

## SAR TEST REPORT

<b>Applicant Name:</b> <b>SAMSUNG Electronics Co., Ltd.</b> 129, Samsung-ro, Yeongtong-gu, Suwon-Si, Gyeonggi-do, 16677 Rep. of Korea	<b>Date of Issue:</b> 03. 04, 2016 <b>Test Report No.:</b> HCT-A-1602-F005-1 <b>Test Site:</b> HCT CO., LTD.
--	--

**FCC ID:**

**A3LSMJ7108**

**Equipment Type:**  
**Model Name:**

**Mobile Phone**  
**SM-J7108**

**Testing has been carried out in accordance with:**

**47CFR §2.1093**  
**ANSI/ IEEE C95.1 - 2005**  
**IEEE 1528-2013**

**Date of Test:**

**02/01/ 2016 ~ 02/04/ 2016**

This device has been shown to be capable of compliance for localized specific absorption rate (SAR) for uncontrolled environment/general population exposure limits specified in FCC KDB procedures and had been tested in accordance with the measurement procedures specified in FCC KDB procedures.

I attest to the accuracy of data. All measurements reported herein were performed by me or were made under my supervision and are correct to the best of my knowledge and belief. I assume full responsibility for the completeness of these measurements and vouch for the qualifications of all persons taking them.

**Tested By**



**Sung-Kun Kwon**  
**Test Engineer / SAR Team**  
**Certification Division**

**Reviewed By**



**Dong-Seob Kim**  
**Technical Manager / SAR Team**  
**Certification Division**

This report only responds to the tested sample and may not be reproduced, except in full, without written approval of the HCT Co., Ltd.

---

## Version

Rev.	DATE	DESCRIPTION
HCT-A-1602-F005	02. 24, 2016	First Approval Report
HCT-A-1602-F005-1	03. 04, 2016	Add the HSPA+ information on sec. 2.2 and sec.9.2

---

# Table of Contents

1. Attestation of Test Result of Device Under Test.....	4
2. Device Under Test Description .....	5
3. INTRODUCTION .....	1 3
4. DESCRIPTION OF TEST EQUIPMENT .....	1 4
5. SAR MEASUREMENT PROCEDURE .....	1 5
6. DESCRIPTION OF TEST POSITION.....	1 7
7. ANSI/ IEEE C95.1 - 2005 RF EXPOSURE LIMITS.....	2 0
8. FCC SAR GENERAL MEASUREMENT PROCEDURES .....	2 1
9. Output Power Specifications .....	2 4
10. SYSTEM VERIFICATION .....	3 6
11. SAR TEST DATA SUMMARY .....	3 8
12. Simultaneous SAR Analysis .....	4 6
13. SAR Measurement Variability and Uncertainty.....	4 9
14. MEASUREMENT UNCERTAINTY .....	4 9
15. SAR TEST EQUIPMENT .....	5 0
16. CONCLUSION.....	5 2
17. REFERENCES .....	5 3
Attachment 1. – SAR Test Plots.....	5 5
Attachment 2. – Dipole Verification Plots.....	5 6
Attachment 3. – Probe Calibration Data .....	8 2
Attachment 4. – Dipole Calibration Data .....	8 6
Attachment 5. – SAR Tissue Characterization .....	1 4 1
Attachment 6. – SAR SYSTEM VALIDATION .....	1 4 2

# 1. Attestation of Test Result of Device Under Test

Test Laboratory	
Company Name:	HCT Co., LTD
Address	74, Seoicheon-ro 578beon-gil, Majang-myeon, Icheon-si, Gyeonggi-do, 17383, Rep. of Korea
Telephone	+82 31 645 6300
Fax.	+82 31 645 6400

Attestation of SAR test result	
Applicant Name:	SAMSUNG Electronics Co., Ltd.
FCC ID:	A3LSMJ7108
Model:	SM-J7108
EUT Type:	Mobile Phone
Application Type:	Certification

The Highest Reported SAR					
Band	Tx. Frequency (MHz)	Equipment Class	Reported 1g SAR		
			Head (W/Kg)	Body-Worn (W/Kg)	Hotspot (W/Kg)
GSM/GPRS 850	824.2 - 848.8	PCE	0.08	0.20	0.22
GSM/GPRS 1900	1 850.2 -1 909.8	PCE	0.13	0.22	0.64
UMTS 850	826.4 - 846.6	PCE	0.09	0.21	0.61
UMTS 1900	1 852.4 - 1 907.6	PCE	0.18	0.37	1.03
LTE 41	2 555 ~ 2 655	PCE	0.07	0.36	1.11
802.11b	2 412 - 2 462	DTS	0.80	0.06	0.13
Bluetooth	2 402 - 2 480	DSS/DTS	-	0.13*	-
Simultaneous SAR per KDB 690783 D01v01r03			0.97	1.23	
Date(s) of Tests:	02/01/2016 ~ 02/04/2016				

### SAR Test Note :

\* BT Body-worn SAR value is estimated SAR value that should not be reported standalone SAR on grants of equipment approval.

## 2. Device Under Test Description

### 2.1 DUT specification

Device Wireless specification overview		
Band & Mode	Operating Mode	Tx Frequency
GSM/GPRS 850	Voice / Data	824.2 – 848.8 MHz
GSM/GPRS 1900	Voice / Data	1 850.0 – 1 909.8 MHz
UMTS 850	Voice / Data	826.4 – 846.6 MHz
UMTS 1900	Voice / Data	1 852.4 – 1 907.6 MHz
LTE TDD Band 41	Data	2 555 – 2 655 MHz
2.4 GHz WLAN	Data	2 412 – 2 462 MHz
Bluetooth	Data	2 402 – 2 480 MHz
NFC	Data	13.56 MHz
ANT+	Data	2402 – 2480 MHz
Device Description		
Device Dimension:	Overall (Length x Width) : 151.6 mm x 76 mm	
Back Cover:	Normal Battery cover	
Battery Options:	Standard	
Hardware Version:	REV0.1	
Software Version :	J7108.01	
Device Serial Numbers	Mode	Serial Number/IMEI
	GSM 850,1900 / UMTS 850, 1900 / LTE 41	R28H134HCHD
	WiFi 2.4GHz	R28H134HCMR
	Several samples with identical hardware were used to SAR testing. The manufacturer has confirmed that the devices tested have the same physical, mechanical and thermal characteristics are within operational tolerances expected for production units.	

## 2.2 DUT Wireless mode

Wireless Modulation	Band	Operating Mode		Duty Cycle
GSM	850 1900	Voice(GMSK) GPRS (GMSK) EGPRS (8PSK)	GPRS/ EDGE Multi-Slot Class: Class 10 – 2 Up, 3 Down Mode class B EDGE Rx only	GSM Voice: 12.5% GPRS 1 Slot: 12.5% 2 Slots : 25%
WCDMA (UMTS)	Band 5 Band 2	UMTS Rel.99 (Voice / DATA) HSDPA (Rel. 5) HSUPA (Rel. 6) DC- HSDPA (Rel. 8) HSPA+ (Rel. 9) (Uplink QPSK Only)		100 %
LTE Band	41	Data (QPSK, 16QAM)		63.3 % (TDD)
2.4 GHz WLAN		Data	802.11 b, 802.11 g, 802.11 n (HT20)	99.08 %
Bluetooth		Data	4.1 LE	N/A
Others		This EUT support dual SIM cards. SIM path is using same RF path. This device was tested with SIM 1. This device supports Mobile Hotspot.		

## 2.3 LTE information

Item.		Description					
Frequency Range:		Band 41: 2 555 MHz – 2 655 MHz					
Channel Bandwidths		Band 41: 5 MHz, 10 MHz, 15 MHz, 20 MHz					
Channel Number s& Frequencies(MHz):							
Band 41							
5 MHz		10 MHz		15 MHz		20 MHz	
Ch.	Freq. (MHz)	Ch.	Freq. (MHz)	Ch.	Freq. (MHz)	Ch.	Freq. (MHz)
40265	2557.5	40290	2560.0	40315	2562.5	40340	2565.0
40620	2593.0	40620	2593.0	40620	2593.0	40620	2593.0
41215	2652.5	41190	2650.0	41165	2647.5	41140	2645.0
Item.		Description					
UE Category		UE Category 6					
LTE Carrier Aggregation Possible Combinations		LTE B41 (PCC) + LTE B41 (SCC)					
		10MHz(B41)+10MHz(B41)		10MHz(B41)+15MHz(B41)		10MHz(B41)+20MHz(B41)	
		15MHz(B41)+10MHz(B41)		15MHz(B41)+15MHz(B41)		15MHz(B41)+20MHz(B41)	
		20MHz(B41)+10MHz(B41)		20MHz(B41)+15MHz(B41)		20MHz(B41)+20MHz(B41)	
Modulations Supported in UL		QPSK, 16QAM					
LTE voice/data requirements		Data Only,					
		LTE voice is available via VoIP. Considering the users may install 3rd party software to enable VoIP, LTE Head SAR is also evaluated.					
LTE MPR options		The EUT incorporates MPR as per 3GPP TS 36.101 sec. 6.2.3 ~ 6.2.5 (Manufacturer attestation to be provided)					
		The MPR is permanently built-in by design as a mandatory.					
		A-MPR is not implemented in the DUT.					
Description of the LTE Transmitter & antenna		This model has two Tx. paths.					
		One is for GSM and WCDMA and LTE. It can not transmit simultaneously.					
		The other is for BT & WLAN. It can not transmit simultaneously.					
Power reduction explanation		This device doesn't implements power reduction.					
LTE Release 10 Additional Information		This device does not support full CA feature on 3GPP Release 10. It supports a maximum of 2 carriers in the downlink. All uplink communications are identical to the Release 8 specifications. Uplink communications are done on the PCC. Due to carrier capability, only the combinations listed above are supported. The following LTE release 10 features are not supported: Replay, HetNet, Enhanced MIMO, eICI, WIFI offloading, MDH, eMBHA, Cross-Carrier Scheduling, Enhanced SC-FDMA.					
Description of the test equipment, software, etc.		LTE SAR Testing was performed using a CMW500. UE transmits with maximum output power during SAR testing.					

## 2.4 TEST METHODOLOGY and Procedures

The tests documented in this report were performed in accordance with IEEE Standard 1528-2013 & IEEE 1528-2005 and the following published KDB procedures.

- FCC KDB Publication 941225 D01 3G SAR Procedures v03r01
- FCC KDB Publication 941225 D06 Hot Spot SAR v02r01
- FCC KDB Publication 941225 D05 SAR for LTE Devices v02r05
- FCC KDB Publication 941225 D05A LTE Rel.10 KDB Inquiry sheet v01r02
- FCC KDB Publication 248227 D01 802.11 Wi-Fi SAR v02r02
- FCC KDB Publication 447498 D01 General SAR Guidance v06
- FCC KDB Publication 648474 D04 Handset SAR v01r03
- FCC KDB Publication 865664 D01 SAR measurement 100 MHz to 6 GHz v01r04
- FCC KDB Publication 865664 D02 SAR Reporting v01r02
- October 2013 TCB Workshop Notes (GPRS testing criteria)
- April 2015 TCB Workshop Notes (Simultaneous transmission summation clarified)

## 2.5 Nominal and Maximum Output Power Specifications

This device operates using the following maximum output power specifications. SAR values were scaled to the maximum allowed power to determine compliance per KDB publication 447498 D01v06.

### 2.5.1 Maximum Output Power

Mode / Band		Voice (dBm)	Burst Average GMSK (dBm)	
		1 Tx Slot	1 Tx Slot	2 Tx Slot
GSM/GPRS 850	Maximum	33.0	33.0	30.0
	Nominal	32.5	32.5	29.5
GSM/GPRS 1900 (LOW band)	Maximum	29.5	29.5	<b>28.5</b>
	Nominal	29.0	29.0	<b>28.0</b>
GSM/GPRS 1900 (Mid band)	Maximum	29.5	29.5	<b>27.5</b>
	Nominal	29.0	29.0	<b>27.0</b>
GSM/GPRS 1900 (High band)	Maximum	29.5	29.5	<b>27.5</b>
	Nominal	29.0	29.0	<b>27.0</b>

Mode / Band		3GPP WCDMA	3GPP HSDPA	3GPP HSUPA	3GPP DC-HSDPA
		(dBm)	(dBm)	(dBm)	(dBm)
UMTS Band 5 (850 MHz)	Maximum	23.5	23.5	21.5	23.5
	Nominal	23.0	23.0	21.0	23.0
UMTS Band 2 (1900 MHz)	Maximum	22.0	22.0	20.5	22.0
	Nominal	21.5	21.5	20.0	21.5

Mode / Band		Modulated Average (dBm)
LTE Band 41	Maximum	<b>24.0</b>
	Nominal	<b>23.5</b>

Mode / Band		Modulated Average (dBm)	
IEEE 802.11b (2.4 GHz)	Maximum	16.5	
	Nominal	16.0	
IEEE 802.11g (2.4 GHz)	Maximum	13.5	
	Nominal	13.0	
IEEE 802.11n (2.4 GHz)	Maximum	12.5	
	Nominal	12.0	
Bluetooth	DH5	Maximum	9.5
		Nominal	9.0
	2-DH5	Maximum	4.5
		Nominal	4.0
	3-DH5	Maximum	4.5
		Nominal	4.0
Bluetooth LE	Maximum	8.0	
	Nominal	7.5	

## 2.6 DUT Antenna Locations

Device Edges / Sides for SAR Testing						
Mode	Rear	Front	Left	Right	Bottom	Top
GSM/GPRS 850	Yes	Yes	Yes	Yes	Yes	No
GSM/GPRS 1900	Yes	Yes	Yes	Yes	Yes	No
UMTS 850	Yes	Yes	Yes	Yes	Yes	No
UMTS 1900	Yes	Yes	Yes	Yes	Yes	No
LTE Band 41	Yes	Yes	Yes	Yes	Yes	No
2.4 GHz WLAN	Yes	Yes	No	Yes	No	Yes

Particular EUT edges were not required to be evaluated for Wireless Router SAR if the edges were > 25 mm from the transmitting antenna according to FCC KDB 941225 D06v02r01 on page 2. The distance between the transmit antennas and the edges of the device are included in the filing. The overall dimensions of this device are > 9 X 5 cm. A diagram showing device antenna can be found in SAR\_setup\_photos. Since the diagonal dimension of this device is > 160 mm and < 200 mm, it is considered a “phablet”.

**Note;** All test configurations are based on front view.

## 2.7 SAR Summation Scenario

According to FCC KDB 447498 D01v06, transmitters are considered to be transmitting simultaneously when there is overlapping transmission, with the exception of transmissions during network hand-offs with maximum hand-off duration less than 30 seconds. Possible transmission paths for the EUT are shown below paths and are mode in same rectangle to indicate communication modes which share the same path. Modes which share the same transmission path cannot transmit simultaneously with one another.



Simultaneous transmission paths

This device contains multiple transmitters that may operate simultaneously, and therefore requires a simultaneous transmission analysis according to FCC KDB 447498 D01v06.

Simultaneous Transmission Scenarios			
Applicable Combination	Head	Body-Worn	Hotspot
GSM Voice + 2.4 GHz WiFi	Yes	Yes	N/A
GSM Voice + 2.4 GHz Bluetooth	N/A	Yes	N/A
GPRS + 2.4 GHz WiFi	N/A	N/A	Yes
UMTS + 2.4 GHz WiFi	Yes	Yes	Yes
UMTS + 2.4 GHz Bluetooth	N/A	Yes	N/A
LTE+ 2.4 GHz WiFi	Yes	Yes	Yes
LTE+ 2.4 GHz Bluetooth	N/A	Yes	N/A

1. 2.4 GHz WLAN and 2.4 GHz Bluetooth share antenna path and cannot transmit simultaneously
2. All licensed modes share the same antenna path and cannot transmit simultaneously.
3. UMTS +WLAN scenario also represents the UMTS Voice/DATA + WLAN hotspot scenario.
4. Per the manufacturer, GPRS does not support VOIP service.
5. This device does not support VoLTE.
6. LTE is considered pre-installed VOIP applications.
7. The highest reported SAR for each exposure condition is used for SAR summation purpose.

## 2.8 SAR Test Exclusions Applied

### (A) BT & BT LE

Per FCC KDB 447498 D01v06, The SAR exclusion threshold for distance < 50mm is defined by the following equation:

$$\frac{\text{Max Power of Channel}(mW)}{\text{Test Separation Distance} (mm)} * \sqrt{\text{Frequency}(GHz)} \leq 3.0$$

Mode	Frequency	Maximum Allowed Power	Separation Distance	≤ 3.0
	[MHz]	[mW]	[mm]	
Bluetooth	2 480	9	15	0.94
Bluetooth LE	2 480	6	15	0.63

Based on the maximum conducted power of Bluetooth and antenna to use separation distance, Bluetooth SAR was not required  $[(9/15)*\sqrt{2.480}] = 0.94 < 3.0$ .

Based on the maximum conducted power of Bluetooth LE and antenna to use separation distance, Bluetooth LE SAR was not required  $[(6/15)*\sqrt{2.480}] = 0.63 < 3.0$ .

This device contains transmitters that may operate simultaneously. Therefore simultaneous transmission analysis is required. Per FCC KDB 447498 D01v06 IV.C.1iii, simultaneous transmission SAR test exclusion may be applied when the sum of the 1-g SAR for all the simultaneous transmitting antennas in a specific a physical test configuration is ≤ 1.6W/kg. When standalone SAR is not required to be measured per FCC KDB 447498 D01v06 4.3.22, the following equation must be used to estimate the standalone 1-g SAR for simultaneous transmission assessment involving that transmitter.

$$\text{Estimated SAR} = \frac{\sqrt{f(GHZ)}}{7.5} * \frac{(\text{Max Power of channel } mW)}{\text{Min Separation Distance}}$$

Mode	Frequency	Maximum Allowed Power	Separation Distance (Body)	Estimated SAR (Body)
	[MHz]	[mW]	[mm]	[W/kg]
Bluetooth	2 480	9	15	0.13
Bluetooth LE	2 480	6	15	0.08

**Note :**

1) Held-to ear configurations are not applicable to Bluetooth and Bluetooth LE operations and therefore were not considered for simultaneous transmission. The Estimated SAR results were determined according to FCC KDB447498 D01v06.

2) The frequency of Bluetooth and Bluetooth LE using for estimated SAR was selected highest channel of Bluetooth LE for highest estimated SAR.

**(B) Licensed Transmitter(s)**

GSM/GPRS/EDGE is not supported for US bands. Therefore, the GSM Voice modes in this report do not transmit simultaneously with GPRS/EDGE Data.

This device is only capable of QPSK HSUPA in the uplink. Therefore, no additional SAR tests are required beyond that described for devices with HSUPA in KDB 941225 D01v03r01.

LTE SAR for the higher modulations and lower bandwidths were not tested since the maximum average output power of all required channels and configurations was not more than 0.5 dB higher than the highest bandwidth; and the reported LTE SAR for the highest bandwidth was less than 1.45 W/kg for all configurations according to FCC KDB 941225 D05v02r05.

Per FCC KDB 648474 D04v01r03, this device is considered a “Phablet” since the diagonal dimension is greater than 160 mm and less than 200 mm. Therefore, extremity SAR tests are required when wireless router mode does not apply or if wireless router 1g SAR >1.2 W/kg. When hotspot mode applies, 10g SAR required only for the surfaces and edges with hotspot mode scaled to the maximum output power (including tolerance) is 1g SAR > 1.2 W/kg.

Per FCC KDB 941225 D01v03r01, 12.2 kbps RMC is the primary mode and HSPA (HSUPA/HSDPA with RMC) is the secondary mode.

Per FCC KDB 941225 D01v03r01, The SAR test exclusion is applied to the secondary mode by the following equation.

$$\text{Adjusted SAR} = \text{Highest Reported SAR} * \frac{\text{Secondary Max tune - up (mW)}}{\text{Primary Max tune - up(mW)}} \leq 1.2 \text{ W/kg.}$$

Based on the highest Reported SAR, the secondary mode is not required.

$$[1.029 * (158/158)] = 1.029 \text{ W/kg} \leq 1.2 \text{ W/kg}$$

And the maximum output power and tune-up tolerance in secondary mode is ≤ 0.25 dB higher than the primary mode.

### 3. INTRODUCTION

The FCC has adopted the guidelines for evaluating the environmental effects of radio frequency radiation in ET Docket 93-62 on Aug. 6, 1996 to protect the public and workers from the potential hazards of RF emissions due to FCC-regulated portable devices.

The safety limits used for the environmental evaluation measurements are based on the criteria published by the American National Standards Institute (ANSI) for localized specific absorption rate (SAR) in IEEE/ANSI C95.1-2005 Standard for Safety Levels with Respect to Human Exposure to Radio Frequency Electromagnetic Fields, 3 kHz to 300 GHz. 1992 by the Institute of Electrical and Electronics Engineers, Inc., Ne York, New York 10017. The measurement procedure described in IEEE/ANSI C95.3-1992 Recommended Practice for the Measurement of Potentially Hazardous Electromagnetic Fields - RF and Microwave is used for guidance in measuring SAR due to the RF radiation exposure from the Equipment Under Test (EUT). These criteria for SAR evaluation are similar to those recommended by the National Council on Radiation Protection and Measurements (NCRP) in Biological Effects and Exposure Criteria for Radio frequency Electromagnetic Fields,” NCRP Report No. 86 NCRP, 1986, Bethesda, MD 20814. SAR is a measure of the rate of energy absorption due to exposure to an RF transmitting source. SAR values have been related to threshold levels for potential biological hazards.

#### SAR Definition

Specific Absorption Rate (SAR) is defined as the time derivative of the incremental electromagnetic energy (dW) absorbed by (dissipated in) an incremental mass (dm) contained in a volume element (dV) of a given density (r). It is also defined as the rate of RF energy absorption per unit mass at a point in an absorbing body.

$$SAR = \frac{d}{dt} \left( \frac{dU}{dm} \right) = \frac{d}{dt} \left( \frac{dU}{\rho dv} \right)$$

Figure 1. SAR Mathematical Equation

*SAR is expressed in units of Watts per Kilogram (W/kg)*

$$SAR = \sigma E^2 / \rho$$

Where:

- $\sigma$  = conductivity of the tissue-simulant material (S/m)
- $\rho$  = mass density of the tissue-simulant material (kg/m<sup>3</sup>)
- $E$  = Total RMS electric field strength (V/m)

NOTE: The primary factors that control rate of energy absorption were found to be the wavelength of the incident field in relations to the dimensions and geometry of the irradiated organism, the orientation of the organism in relation to the polarity of field vectors, the presence of reflecting surfaces, and whether conductive contact is made by the organism with a ground plane.

## 4. DESCRIPTION OF TEST EQUIPMENT

### 4.1 SAR MEASUREMENT SETUP

These measurements are performed using the DASY4 automated dosimetric assessment system. It is made by Schmid & Partner Engineering AG (SPEAG) in Zurich, Switzerland. It consists of high precision robotics system (Staubli), robot controller, Pentium III computer, near-field probe, probe alignment sensor, and the generic twin phantom containing the brain equivalent material. The robot is a six-axis industrial robot performing precise movements to position the probe to the location (points) of maximum electromagnetic field (EMF) (see Figure.2).

A cell controller system contains the power supply, robot controller, teach pendant (Joystick), and remote control, is used to drive the robot motors. The PC with Windows XP or Windows 7 is working with SAR Measurement system DASY4 & DASY5, A/D interface card, monitor, mouse, and keyboard. The Staubli Robot is connected to the cell controller to allow software manipulation of the robot. A data acquisition electronic (DAE) circuit performs the signal amplification, signal multiplexing, AD-conversion, offset measurements, mechanical surface detection, collision detection, etc. is connected to the Electro-optical coupler (EOC). The EOC performs the conversion from the optical into digital electric signal of the DAE and transfers data to the PC plug-in card.

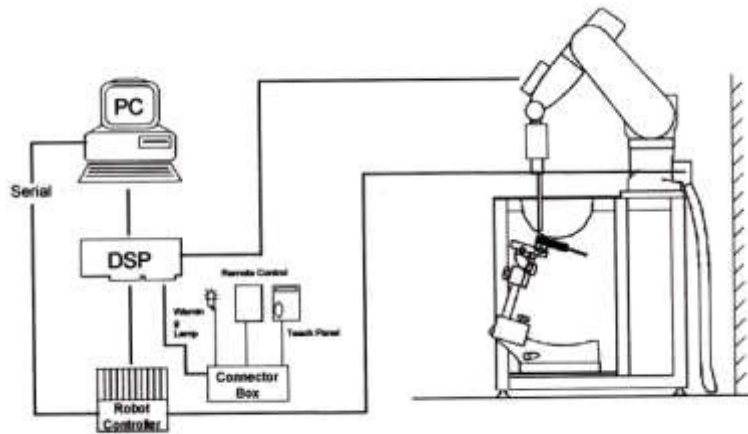

Figure 2. HCT SAR Lab. Test Measurement Set-up

The DAE consists of a highly sensitive electrometer-grade preamplifier with auto-zeroing, a channel and gain-switching multiplexer, a fast 16 bit AD-converter and a command decoder and control logic unit. Transmission to the PC-card is accomplished through an optical downlink for data and status information and an optical uplink for commands and clock lines. The mechanical probe mounting device includes two different sensor systems for frontal and sidewise probe contacts. They are also used for mechanical surface detection and probe collision detection. The robot uses its own controller with a built in VME-bus computer. The system is described in detail in.

## 5. SAR MEASUREMENT PROCEDURE

The evaluation was performed with the following procedure:

1. The SAR distribution at the exposed side of the head or body was measured at a distance no more than 5.0 mm from the inner surface of the shell. The area covered the entire dimension of the DUT's head and body area and the horizontal grid resolution was depending on the FCC KDB 865664 D01v01r04 table 4-1 & IEEE 1528-2013.
2. Based on step, the area of the maximum absorption was determined by sophisticated interpolations routines implemented in DASY software. When an Area Scan has measured all reachable point. DASY system computes the field maximal found in the scanned are, within a range of the maximum. SAR at this fixed point was measured and used as a reference value.
3. Around this point, a volume was assessed according to the measurement resolution and volume size requirements of FCC KDB 865664 D01v01r04 table 4-1 and IEEE 1528-2013. On the basis of this data set, the spatial peak SAR value was evaluated with the following procedure (reference from the DASY manual.)
  - a. The data at the surface were extrapolated, since the center of the dipoles is no more than 2.7 mm away from the tip of the probe (it is different from the probe type) and the distance between the surface and the lowest measuring point is 1.2 mm. The extrapolation was based on a least square algorithm. A polynomial of the fourth order was calculated through the points in z-axes. This polynomial was then used to evaluate the points between the surface and the probe tip.
  - b. The maximum interpolated value was searched with a straight-forward algorithm. Around this maximum the SAR values averaged over the spatial volumes (1 g or 10 g) were computed using the 3D-Spline interpolation algorithm. The 3D-spline is composed of three one-dimensional splines with the "Not a knot" condition (in x, y, and z directions. The volume was integrated with the trapezoidal algorithm. One thousand points (10 x 10 x 10) were interpolated to calculate the average.
  - c. All neighboring volumes were evaluated until no neighboring volume with a higher average value was found.
4. The SAR reference value, at the same location as step 2, was re-measured after the zoom scan. If the value changed by more than 5 %, the SAR evaluation and drift measurements were repeated.

Area scan and zoom scan resolution setting follow KDB 865664 D01v01r04 quoted below.

		≤ 3 GHz	> 3 GHz
Maximum distance from closest measurement point (geometric center of probe sensors) to phantom surface		5±1 mm	$\frac{1}{2} \delta \cdot \ln(2) \pm 0.5$ mm
Maximum probe angle from probe axis to phantom surface normal at the measurement location		30°±1°	20°±1°
Maximum area scan Spatial resolution: $\Delta x_{Area}, \Delta y_{Area}$		≤ 2 GHz: ≤15 mm 2-3 GHz: ≤12 mm	3-4 GHz: ≤12 mm 4-6 GHz: ≤10 mm
		When the x or y dimension of the test device, in the measurement plane orientation, is smaller than the above, the measurement resolution must be ≤ the corresponding x or y dimension of the test device with at least one measurement point on the test device.	
Maximum zoom scan Spatial resolution: $\Delta x_{zoom}, \Delta y_{zoom}$		≤ 2 GHz: ≤8mm 2-3 GHz: ≤5mm*	3-4 GHz: ≤5 mm* 4-6 GHz: ≤4 mm*
Maximum zoom scan Spatial resolution normal to phantom surface	uniform grid: $\Delta z_{zoom}(n)$	≤ 5 mm	3-4 GHz: ≤4 mm 4-5 GHz: ≤3 mm 5-6 GHz: ≤2 mm
	graded grid $\Delta z_{zoom}(1)$ : between 1 <sup>st</sup> two Points closest to phantom surface	≤ 4 mm	3-4 GHz: ≤3 mm 4-5 GHz: ≤2.5 mm 5-6 GHz: ≤2 mm
	$\Delta z_{zoom}(n>1)$ : between subsequent Points	≤1.5· $\Delta z_{zoom}(n-1)$	
Minimum zoom scan volume	x, y, z	≥ 30 mm	3-4 GHz: ≥28 mm 4-5 GHz: ≥25 mm 5-6 GHz: ≥22 mm
<p>Note: <math>\delta</math> is the penetration depth of a plane-wave at normal incidence to the tissue medium; see draft standard IEEE P1528-2011 for details.</p> <p>* When zoom scan is required and the reported SAR from the area scan based 1-g SAR estimation procedures of KDB 447498 is ≤ 1.4 W/kg, ≤ 8 mm, ≤ 7 mm and ≤ 5 mm zoom scan resolution may be applied, respectively, for 2 GHz to 3 GHz, 3 GHz to 4 GHz and 4 GHz to 6 GHz.</p>			

## 6. DESCRIPTION OF TEST POSITION

### 6.1 EAR REFERENCE POINT

Figure 6-2 shows the front, back and side views of the SAM phantom. The center-of-mouth reference point is labeled “M”, the left ear reference point (ERP) is marked “LE”, and the right ERP is marked “RE.” Each ERP is on the B-M (back-mouth) line located 15 mm behind the entrance-to-ear-canal (EEC) point, as shown in Figure 6-1. The Reference Plane is defined as passing through the two ear reference point and point M. The line N-F (Neck-Front), also called the Reference Pivoting Line, is not perpendicular to the reference plane (See Figure 5-1), Line B-M is perpendicular to the N-F line. Both N-F and B-M lines are marked on the external phantom shell to facilitate handset positioning.

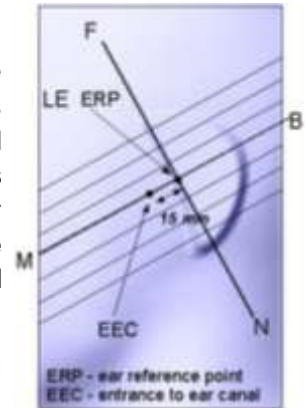

Figure 6-1  
Close-up side view of ERP

### 6.2 HEAD POSITION

Two imaginary lines on the handset were established: the vertical centerline and the horizontal line. The device under test was placed in a normal operating position with the acoustic output located along the “vertical centerline” on the front of the device aligned to the “ear reference point”(see Figure 6-3). The acoustic output was then located at the same level as the center of the ear reference point. The device under test was positioned so that the “vertical centerline” was bisecting the front surface of the handset at its top and bottom edges, positioning the “ear reference point” on the outer surface of the both the left and right head phantoms on the ear reference point.



Figure 6-2  
Front, back and side views of SAM Twin Phantom

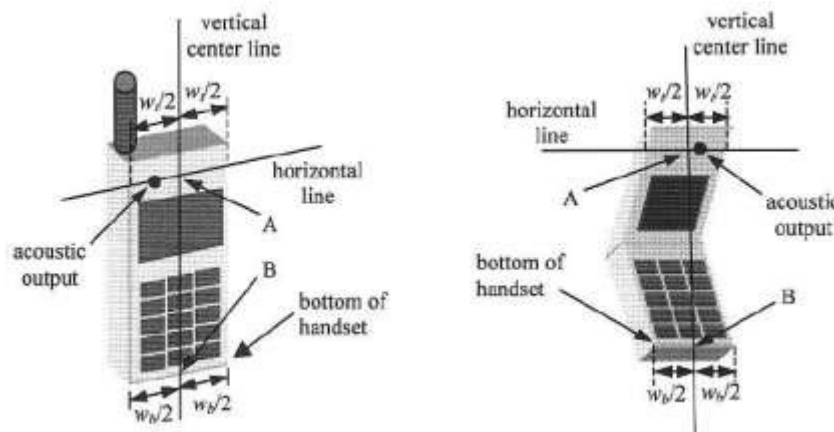

Figure 6-3. Handset vertical and horizontal reference lines

## 6.3 Body Holster/Belt Clip Configurations

Body-worn operating configurations are tested with the belt-clips and holsters attached to the device and positioned against a flat phantom in a normal use configuration. A device with a headset output is tested with a headset connected to the device. Body dielectric parameters are used.

Accessories for Body-worn operation configurations are divided into two categories: those that do not contain metallic components and those that contain metallic components. When multiple accessories that do not contain metallic components are supplied with the device, the device is tested with only the accessory that dictates the closest spacing to the body. Then multiple accessories that contain metallic components are tested with each accessory. If multiple accessories share an identical metallic component (i.e. the same metallic belt-clip used with different holsters with no other metallic components) only the accessory that dictates the closest spacing to the body is tested.

Body-worn accessories may not always be supplied or available as options for some Devices intended to be authorized for body-worn use. In this case, a test configuration with a separation distance between the back of the device and the flat phantom is used.

Since this EUT does not supply any body worn accessory to the end user a distance of 1.5 cm from the EUT back surface to the liquid interface is configured for the generic test.

"See the Test SET-UP Photo"

Transmitters that are designed to operate in front of a person's face, as in push-to-talk configurations, are tested for SAR compliance with the front of the device positioned to face the flat phantom. For devices that are carried next to the body such as a shoulder, waist or chest-worn transmitters, SAR compliance is tested with the accessory(ies), including headsets and microphones, attached to the device and positioned against a flat phantom in a normal use configuration.

In all cases SAR measurements are performed to investigate the worst-case positioning. Worst case positioning is then documented and used to perform Body SAR testing.

## 6.4 Body-Worn Accessory Configurations

Body-worn operating configurations are tested with the belt-clips and holsters attached to the device and positioned against a flat phantom in a normal use configuration (see Figure 6-4). Per FCC KDB Publication 648474 D04v01r03 Body-worn accessory exposure is typically related to voice mode operations when handsets are carried in Body-worn accessories. The Body-worn accessory procedures in FCC KDB Publication 447498 D01v06 should be used to test for Body-worn accessory SAR compliance, without a headset connected to it. This enables the test results for such configuration to be compatible with that required for hotspot mode when the Body-worn accessory test separation distance is greater than or equal to that required for hotspot mode, when applicable. When the reported SAR for a body-worn accessory, measured without a headset connected to the handset, is  $> 1.2 \text{ W/kg}$ , the highest reported SAR configuration for that wireless mode and frequency band should be repeated for that body-worn accessory with a headset attached to the handset.



Figure 6-4  
Sample Body-Worn Diagram

Accessories for Body-worn operation configurations are divided into two categories: those that do not contain metallic components and those that do contain metallic components. When multiple accessories that do not contain metallic components are supplied with the device, the device is tested with only the accessory that dictates the closest spacing to the body. Then multiple accessories that contain metallic components are tested with the device with each accessory. If multiple accessories share an identical metallic component (i.e. the same metallic belt-clip used with different holsters with no other metallic components) only the accessory that dictates the closest spacing to the body is tested.

Body-worn accessories may not always be supplied or available as options for some devices intended to be authorized for Body-worn use. In this case, a test configuration with a separation distance between the back of the device and the flat phantom is used. Test position spacing was documented.

Transmitters that are designed to operate in front of a person's face, as in push-to-talk configurations, are tested for SAR compliance with the front of the device positioned to face the flat phantom in head fluid. For devices that are carried next to the body such as a shoulder, waist or chest-worn transmitters. SAR compliance is tested with the accessories, including headsets and microphones, attached to the device and positioned against a flat phantom in a normal use configuration.

## 6.5 Wireless Router Configurations

Some battery-operated handsets have the capability to transmit and receive user data through simultaneous transmission of WIFI simultaneously with a separate licensed transmitter. The FCC has provided guidance in FCC KDB Publication 941225 D06v02r01 where SAR test considerations for handsets ( $L \times W \geq 9\text{cm} \times 5\text{cm}$ ) are based on a composite test separation distance of 10 mm from the front back and edges of the device containing transmitting antennas within 2.5 cm of their edges, determined from general mixed use conditions for this type of devices. Since the hotspot SAR results may overlap with the Body-worn accessory SAR requirements, the more conservative configurations can be considered, thus excluding some Body-worn accessory SAR tests.

When the user enables the personal wireless router functions for the handset actual operations include simultaneous transmission of both the WIFI transmitter and another licensed transmitter. Both transmitters often do not transmit at the same transmitting frequency and thus cannot be evaluated for SAR under actual use conditions due to the limitations of the SAR assessment probes. Therefore, SAR must be evaluated for each frequency transmission and mode separately and spatially summed with the WIFI transmitter according to FCC KDB Publication 447498 D01v06 publication procedures. The "Portable Hotspot\*" feature on the handset was NOT activated during SAR assessments, to ensure the SAR measurements were evaluated for a single transmission frequency RF signal at a time.

## 7. ANSI/ IEEE C95.1 - 2005 RF EXPOSURE LIMITS

HUMAN EXPOSURE	UNCONTROLLED ENVIRONMENT General Population	CONTROLLED ENVIRONMENT Occupational
	(W/kg) or (mW/g)	(W/kg) or (mW/g)
SPATIAL PEAK SAR * (Brain)	1.60	8.00
SPATIAL AVERAGE SAR ** (Whole Body)	0.08	0.40
SPATIAL PEAK SAR *** (Hands / Feet / Ankle / Wrist)	4.00	20.00

**Table 8.1 Safety Limits for Partial Body Exposure**

### NOTES:

\* The Spatial Peak value of the SAR averaged over any 1 g of tissue (defined as a tissue volume in the shape of a cube) and over the appropriate averaging time.

\*\* The Spatial Average value of the SAR averaged over the whole-body.

\*\*\* The Spatial Peak value of the SAR averaged over any 10 g of tissue (defined as a tissue volume in the shape of a cube) and over the appropriate averaging time.

**Uncontrolled Environments** are defined as locations where there is the exposure of individuals who have no knowledge or control of their exposure. The general population/uncontrolled exposure limits are applicable to situations in which the general public may be exposed or in which persons who are exposed as a consequence of their employment may not be made fully aware of the potential for exposure or cannot exercise control over their exposure. Members of the general public would come under this category when exposure is not employment-related; for example, in the case of a wireless transmitter that exposes persons in its vicinity.

**Controlled Environments** are defined as locations where there is exposure that may be incurred by persons who are aware of the potential for exposure, (i.e. as a result of employment or occupation). In general, occupational/controlled exposure limits are applicable to situations in which persons are exposed as a consequence of their employment, who have been made fully aware of the potential for exposure and can exercise control over their exposure. This exposure category is also applicable when the exposure is of a transient nature due to incidental passage through a location where the exposure levels may be higher than the general population/uncontrolled limits, but the exposed person is fully aware of the potential for exposure and can exercise control over his or her exposure by leaving the area or by some other appropriate means.

## 8. FCC SAR GENERAL MEASUREMENT PROCEDURES

### 8.1 Measured and Reported SAR

Per FCC KDB Publication 447498 D01v06, when SAR is not measured at the maximum power level allowed for production units, the results must be scaled to the maximum tune-up tolerance limit according to the power applied to the individual channels tested to determine compliance. For simultaneous transmission, the measured aggregate SAR must be scaled according to the sum of the differences between the maximum tune-up tolerance and actual power used to test each transmitter. When SAR is measured at or scaled to the maximum tune-up tolerance limit, the results are referred to as Reported SAR. The highest reported SAR results are identified on the grant of equipment authorization according to procedures in KDB 690783 D01v01r03.

### 8.2 3G SAR Test Reduction Procedure

#### 8.2.1 GSM, GPRS AND EDGE

The following procedures may be considered for each frequency band to determine SAR test reduction for devices operating in GSM/GPRS/EDGE modes to demonstrate RF exposure compliance. GSM voice mode transmits with 1 time slot. GPRS and EDGE may transmit up to 4 time slots in the 8 time-slot frame according to the multi-slot class implemented in a device.

#### 8.2.2 SAR Test Reduction

In FCC KDB 941225 D01v03r01, certain transmission modes within a frequency band and wireless mode evaluated for SAR are defined as primary modes. The equivalent modes considered for SAR test reduction are denoted as secondary modes. When the maximum output power including tune-up tolerance specified for production units in a secondary mode is  $\leq 0.25$  dB higher than the primary mode or when the highest reported SAR of the primary mode, scaled by the ratio of specified maximum output power and tune-up tolerance of secondary to primary mode, is  $\leq 1.2$  W/kg, SAR measurements are not required for the secondary mode. These criteria are referred to as the 3G SAR test reduction procedure. When the 3G SAR test reduction procedure is not satisfied, SAR measurements are additionally required for the secondary mode.

SAR test reduction for GPRS and EDGE modes is determined by the source-based time-averaged output power specified for production units, including tune-up tolerance. The data mode with highest specified time-averaged output power should be tested for SAR compliance in the applicable exposure conditions. For modes with the same specified maximum output power and tolerance, the higher number time-slot configuration should be tested

### 8.3 Procedures Used to Establish RF Signal for SAR

The following procedures are according to FCC KDB 941225 D01v03r01 - 3G SAR Measurement Procedures. The handset was placed into a simulated call using a base station simulator in a shielded chamber. Such test signals offer a consistent means for testing SAR and are recommended for evaluation SAR measurements were taken with a fully charged battery. In order to verify that the device was tested and maintained at full power, this was configured with the base station simulator. The SAR measurement Software calculates a reference point at the start and end of the test to Check for power drifts. If conducted Power deviations of more than 5 % occurred, the tests were repeated.

## 8.4 SAR Measurement Conditions for UMTS

### 8.4.1 Output Power Verification

Maximum output power is verified on the High, Middle and Low channels according to the general descriptions in sec. 5.2 of 3GPP TS 34.121, using the appropriate RMC with TPC (transmit power control) set to all "1s" or applying the required inner loop power control procedures to maintain maximum output power while HSUPA is active. Results for all applicable physical channel configurations (DPCCH, DPDCHn and spreading codes, HS-DPCCH etc) are tabulated in this test report. All configurations that are not supported by the DUT or cannot be measured due to technical or equipment limitations are identified.

### 8.4.2 Head SAR Measurements

SAR for next to the ear head exposure is measured using a 12.2 kbps RMC with TPC bits configured to all "1s". The 3G SAR test reduction procedure is applied to AMR configurations with 12.2 kbps RMC as the primary mode. Otherwise, SAR is measured for 12.2 kbps AMR in 3.4 kbps SRB (signaling radio bearer) using the highest reported SAR configuration in 12.2 kbps RMC for head exposure.

### 8.4.3 Body SAR measurements

SAR for body exposure configurations is measured using the 12.2kbps RMC with the TPC bits all "1s". the 3G SAR test reduction procedure is applied to other spreading codes and multiple DPDCHn configurations supported by the handset with 12.2 kbps RMC as the primary mode. Otherwise, SAR is measured using and applicable RMC configuration with the corresponding spreading code or DPDCHn, for the highest reported SAR configuration in 12.2kbps RMC.

### 8.4.4 SAR Measurements with Rel. 5 HSDPA

The 3G SAR test reduction procedure is applied to HSDPA body configurations with 12.2 kbps RMC as the primary mode. Otherwise, Body SAR for HSDPA is measured using and FRC with H-SET 1 in Sub-test and a 12.2 kbps RMC without HSDPA. Handsets with both HSDPA and HSUPA are tested according to release 6 HSPA test procedures. 8.4.5 SAR Measurement with Rel 6 HSUPA The 3G SAR test Reduction Procedure is applied to HSPA (HSUPA/HSDPA with RMC) body configurations with 12.2 kbps RMC as the primary mode. Otherwise, Body SAR for HSPA is measured with E-DCH Sub-test 5, Using H-Set 1 and QPSK for FRC and a 12.2kbps RMC configured in Test Loop Mode 1 and Power Control algorithm 2, according to the highest reported body SAR configuration in 12.2 kbps RMC without HSPA. When VOIP applies to head exposure, the 3G SAR test reduction procedure is applied with 12.2 kbps RMC as the primary mode; otherwise, the same HSPA configuration used for body SAR measurements are applied to head exposure testing.

### 8.4.5 SAR Measurements with Rel. 6 HSUPA

The 3G SAR test reduction procedure is applied to HSPA (HSUPA/HSDPA with RMC) body configurations with 12.2 kbps RMC as the primary mode. Otherwise, Body SAR for HSPA is measured with E-DCH Sub-test 5, using H-Set1 and QPSK for FRC and a 12.2 kbps RMC configured in Test Loop Mode 1 and power control algorithm 2, according to the highest reported body SAR configuration in 12.2 kbps RMC without HSPA.

### 8.4.6 DC-HSDPA

UMTS SAR was tested under RMC 12.2 kbps with HSPA inactive per KDB publication 941225 D01v03r01. HSPA SAR was not required since the average output power of the HSPA subtests was not more than 0.25 dB higher than the RMC level and SAR was less than 1.2 W/kg.

#### DC-HSDPA Considerations:

- 3GPP Specification 34.121-1 Release 8 Ver 8.10.0 was used for DC-HSDPA guidance
- H-Set 12(QPSK) was confirmed to be used during DC-HSDPA measurements
- Measured maximum output powers for DC-HSDPA were not greater than 1/4 dB higher than the WCDMA 12.2 kbps RMC maximum output and as a result, SAR is not required for DC-HSDPA
- The DUT supports UE category 24 for HSDPA.

It is expected by the manufacturer that MPR for some HSUPA subtests may be up to 1 dB more than specified by 3GPP, but also as low as 0 dB according to the chipset implementation in this model.

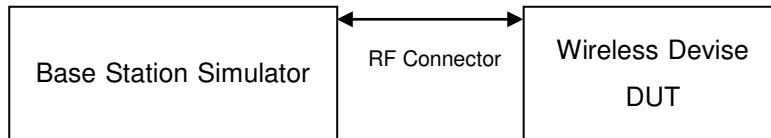

## 8.5 SAR Measurement Conditions for LTE

LTE modes are tested according to FCC KDB 941225 D05v02r05 publication. Establishing connections with base station simulators ensure a consistent means for testing SAR and are recommended for evaluation SAR [4]. The R&S CMW500 or Anritsu MT8820C simulators are used for LTE output power measurements and SAR testing. Closed loop power control was used so the UE transmits with maximum output power during SAR testing. SAR tests were performed with the same number of RB and RB offsets transmitting on all TTI frames (maximum TTI).

### 8.5.1 Spectrum Plots for RB Configurations

A properly configured base station simulator was used for SAR tests and power measurements. Therefore, spectrum plots for RB configurations were not required to be included in this report.

### 8.5.2 MPR

MPR is permanently implemented for this device by the manufacturer. The specific manufacturer target MPR is indicated alongside the SAR results. MPR is enabled for this device, according to 3GPP TS36. 101 Section 6.2.3 – 6.2.5 under Table 6.2.3-1.

### 8.5.3 A-MPR

A-MPR(Additional MPR) has been disabled for all SAR tests by setting NS=01 on the base station simulator.

### 8.5.4 Required RB Size and RB offsets for SAR testing

According to FCC KDB 941225 D05v02r05

- a. Per sec 4.2.1, SAR is required for QPSK 1 RB Allocation for the largest bandwidth
  - i. The required channel and offset combination with the highest maximum output power is required for SAR.
  - ii. When the reported SAR is  $\leq 0.8$  W/Kg, testing of the remaining RB offset configurations and required test channels is not required. Otherwise, SAR is required for the remaining required test channels using the RB offset configuration with highest output power for that channel.
  - iii. When the reported SAR for a required test channel is  $> 1.45$  W/kg, SAR is required for all RB offset configurations for that channel.
- b. Per Sec 4.2.2, SAR is required for 50% RB allocation using the largest bandwidth following the same procedures outlined in Sec 4.2.1.
- c. Per Sec. 4.2.3, QPSK SAR is not required for the 100% allocation when the highest maximum output power for the 100% allocation is less than the highest maximum output power of the 1 RB and 50% RB allocations and the reported SAR for the 1 RB and 50% RB allocations is  $< 0.8$  W/kg.
- d. Per Sec. 4.2.4 and 4.3, SAR test for higher order modulations and lower bandwidths configurations are not required when the conducted power of the required test configurations determined by Sec. 4.2.1 through 4.2.3 is less than or equal to 1/2 dB higher than the equivalent configuration using QPSK modulation and when the QPSK SAR for those configurations is  $< 1.45$  W/Kg.

### 8.5.5 LTE(TDD) Considerations

According to KDB 941225 D05v02r05, for Time-Division Duplex (TDD) systems, SAR must be tested using a fixed periodic duty factor according to the highest transmission duty factor implemented for the device and supported by the defined 3GPP LTE TDD configurations.

SAR was tested with the highest transmission duty factor (63.33 %) using Uplink-downlink configuration 0 and Special subframe configuration 6.

LTE TDD Band 41 supports 3GPP TS 36.211 section 4.2 for Type 2 Frame and Table 4.2-2 for uplink-downlink configurations and Table 4.2-1 for Special subframe configurations.

Table 4.2-1: Configuration of special subframe (lengths of DwPTS/GP/UpPTS)

Special subframe configuration	Normal cyclic prefix in downlink			Extended cyclic prefix in downlink		
	DwPTS	UpPTS		DwPTS	UpPTS	
		Normal cyclic prefix in uplink	Extended cyclic prefix in uplink		Normal cyclic prefix in uplink	Extended cyclic prefix in uplink
0	$6592 \cdot T_s$	$2192 \cdot T_s$	$2560 \cdot T_s$	$7680 \cdot T_s$	$2192 \cdot T_s$	$2560 \cdot T_s$
1	$19760 \cdot T_s$			$20480 \cdot T_s$		
2	$21952 \cdot T_s$			$23040 \cdot T_s$		
3	$24144 \cdot T_s$			$25600 \cdot T_s$		
4	$26336 \cdot T_s$	$4384 \cdot T_s$	$5120 \cdot T_s$	$7680 \cdot T_s$	$4384 \cdot T_s$	$5120 \cdot T_s$
5	$6592 \cdot T_s$			$20480 \cdot T_s$		
6	$19760 \cdot T_s$			$23040 \cdot T_s$		
7	$21952 \cdot T_s$			$12800 \cdot T_s$		
8	$24144 \cdot T_s$			-	-	-
9	$13168 \cdot T_s$			-	-	-

Table 4.2-2: Uplink-downlink configurations.

Uplink-downlink configuration	Downlink-to-Uplink Switch-point periodicity	Subframe number									
		0	1	2	3	4	5	6	7	8	9
0	5 ms	D	S	U	U	U	D	S	U	U	U
1	5 ms	D	S	U	U	D	D	S	U	U	D
2	5 ms	D	S	U	D	D	D	S	U	D	D
3	10 ms	D	S	U	U	U	D	D	D	D	D
4	10 ms	D	S	U	U	D	D	D	D	D	D
5	10 ms	D	S	U	D	D	D	D	D	D	D
6	5 ms	D	S	U	U	U	D	S	U	U	D

Calculated Duty Cycle – Extended cyclic prefix in uplink x ( $T_s$ ) x # of S + # of U

Example for calculated Duty Cycle for Uplink-Downlink Configuration 0:

Calculated Duty Cycle =  $5120 \times [1/(15000 \times 2048)] \times 2 + 6 \text{ ms} = 63.33 \%$

Where

$T_s = 1/(15000 \times 2048)$  seconds

**LTE Band 41**

**Conducted Power Measured Results**

**LTE TDD Band 41 setup method (CMW-500).**

- Physical Cell Setup Menu
- Sub-menu "TDD" and set "Uplink Downlink Configuration" to "0"
- Turn the cell on using "ON : OFF" Key

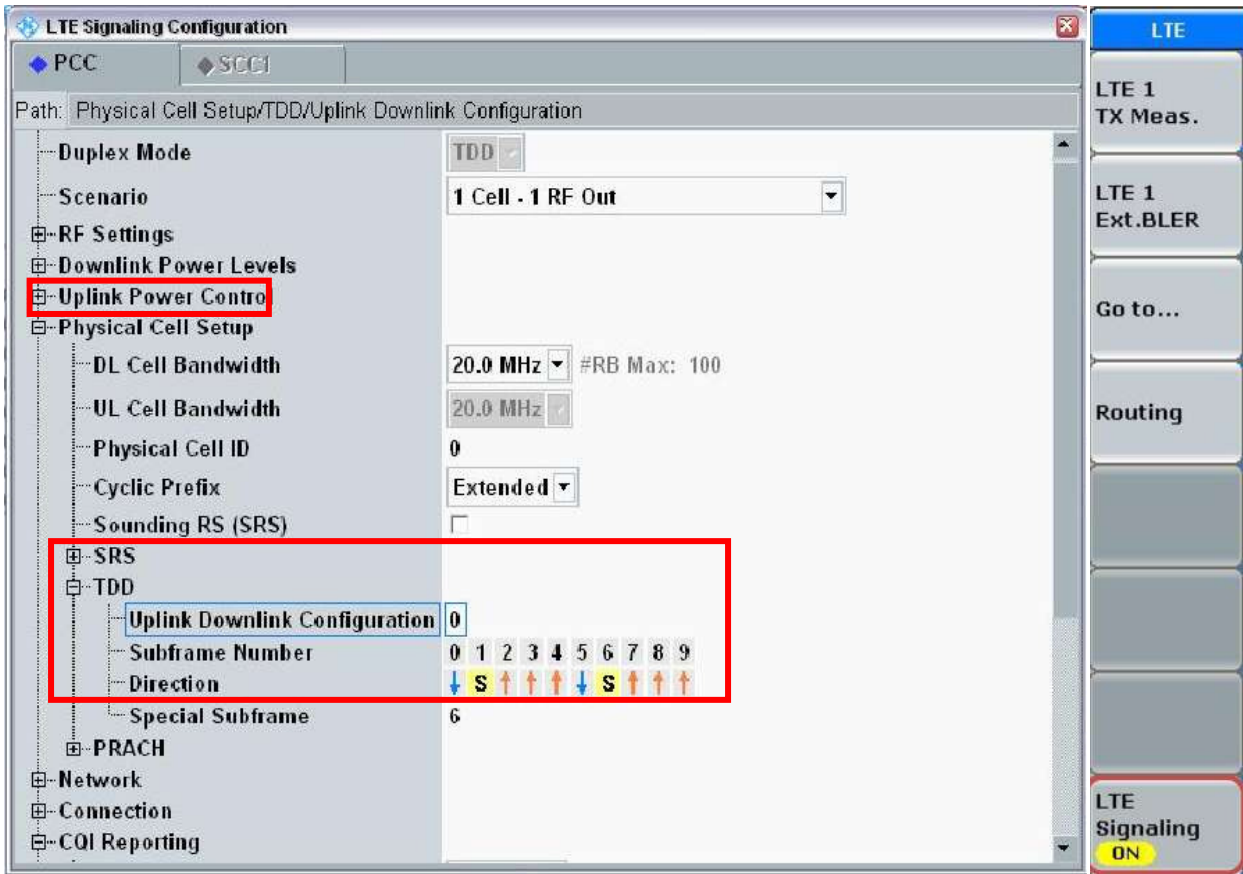

## 8.6 SAR Testing with 802.11 Transmitters

The normal network operating configurations of 802.11 transmitters are not suitable for SAR measurements. Unpredictable fluctuations in network traffic and antenna diversity conditions can introduce undesirable variations in SAR results. The SAR for these devices should be measured using chipset based test mode software to ensure the results are consistent and reliable. See KDB Publication 248227 D01v02r02 for more details.

### 8.6.1 General Device Setup

Chipset based test mode software is hardware dependent and generally varies among manufacturers. The device operating parameters established in test mode for SAR measurements must be identical to those programmed in production units, including output power levels, amplifier gain settings and other RF performance tuning parameters.

A periodic duty factor is required for current generation SAR system to measure SAR. When 802.11 frame gaps are accounted for in the transmission, a maximum transmission duty factor of 92-96% is typically achievable in most test mode configurations. A minimum transmission duty factor of 85% is required to avoid certain hardware and device implementation issues related to wide range SAR scaling. The reported SAR is scaled to 100% transmission duty factor to determine compliance at the maximum tune-up tolerance limit.

### 8.6.4 Initial Test Position Procedure

For exposure conditions with multiple test positions, such as handset operating next to the ear, devices with hotspot mode or UMPC mini-tablet, procedures for initial test position can be applied. Using the transmission mode determined by the DSSS procedure or initial test configuration, area scans are measured for all positions in an exposure condition. The test position with the highest extrapolated (peak) SAR is used as the initial test position. When reported SAR for the initial test position is  $\leq 0.4$  W/kg for 1g SAR and  $\leq 1.0$  W/kg for 10g SAR, no additional testing for the remaining test position is required. Otherwise, SAR is evaluated at the subsequent highest peak SAR positions until the reported SAR result is  $\leq 0.8$  W/kg for 1g SAR and  $\leq 2.0$  W/kg for 10g SAR or all test positions are measured.

### 8.6.5 2.4 GHz SAR test Requirements

SAR is measured for 2.4 GHz 802.11b DSSS using either the fixed test position or, when applicable, the initial test position procedure. SAR test reduction is determined according to the following:

- 1) When the reported SAR of the highest measured maximum output power channel for the exposure configuration is  $\leq 0.8$  W/kg, no further SAR testing is required for 802.11b DSSS is that exposure configuration.
- 2) When the reported SAR is  $> 0.8$  W/kg, SAR is required for that position using the next highest measured output power channel. When any reported SAR is  $> 1.2$  W/kg, SAR is required for the third channel; i.e., all channels require testing.

2.4 GHz 802.11 g/n OFDM are additionally evaluated for SAR if the highest reported SAR for 802.11b, adjusted by the ratio of the OFDM to DSSS specified maximum output power, is  $> 1.2$  W/kg. When SAR is required for OFDM modes in 2.4 GHz band, the Initial Test Configuration Procedures should be followed.

### 8.6.6 OFDM Transmission Mode and SAR Test channel Selection

For the 2.4 GHz, when the same maximum output power was specified for multiple OFDM transmission mode configurations in a frequency band or aggregated band, SAR is measured using the configuration with the largest channel bandwidth, lowest order modulation and lowest data rate and lowest order 802.11 g/n mode. When the maximum output power of a channel is the same for equivalent OFDM configurations; for example, 802.11g and 802.11n with the same channel bandwidth, modulation and data rate etc., the lower order 802.11 mode i.e., 802.11g then 802.11n, is used for SAR measurement. When the maximum output power are the same for multiple test channels, either according to the default or additional power measurement requirements, SAR is measured using the channel closest to the middle of the frequency band or aggregated band. When there are multiple channels with the same maximum output power, SAR is measured using the higher number channel.

### 8.6.7 Initial Test configuration Procedure

For OFDM, in both 2.4 GHz, an initial test configuration is determined for each frequency band and aggregated band, according to the transmission mode with the highest maximum output power specified for SAR measurements. When the same maximum output power is specified for multiple OFDM transmission mode configurations in a frequency band or aggregated band, SAR is measured using the configuration(s) with the largest channel bandwidth, lowest order modulation, and lowest data rate. If the average RF output powers of the highest identical transmission modes are within 0.25 dB of each other, mid channel of the transmission mode with highest average RF output power is the initial test channel. Otherwise, the channel of the transmission mode with the highest average RF output conducted power will be the initial test configuration.

When the reported SAR is  $\leq 0.8$  W/kg, no additional measurements on other test channels are required. Otherwise, SAR is evaluated using the subsequent highest average RF output channel until the reported SAR result is 1.2 W/kg or all channels are measured. When there are multiple untested channels having the same subsequent highest average RF output power, the channel with higher frequency from the lowest 802.11 mode is considered for SAR measurements.

### 8.6.8 Subsequent Test Configuration Procedures

For OFDM configurations in each frequency band and aggregated band, SAR is evaluated for initial test configuration using the fixed test position or the initial test position on procedure. When the highest reported SAR (for the initial test configuration), adjusted by the ratio of the specified maximum output power of the subsequent test configuration to initial test configuration, is  $\leq 1.2$  W/kg for 1g SAR and  $\leq 3.0$  W/kg for 10g SAR, no additional SAR tests for the subsequent test configurations are required.

## 9. Output Power Specifications

This device operates using the following maximum output power specifications. SAR values were scaled to the maximum allowed power to determine compliance per KDB publication 447498 D01v06.

### 9.1 GSM

GSM Conducted output powers (Burst-Average)

Band	Channel	Voice	GPRS(GMSK) Data – CS1	
		GSM (dBm)	GPRS 1 TX Slot (dBm)	GPRS 2 TX Slot (dBm)
GSM 850	128	32.12	32.12	29.65
	190	31.81	31.84	29.41
	251	32.07	32.07	29.68
GSM 1900	512	29.40	29.42	<b>28.29</b>
	661	29.00	28.97	26.99
	810	28.91	28.93	26.75

GSM Conducted output powers (Frame-Average)

Band	Channel	Voice	GPRS(GMSK) Data – CS1	
		GSM (dBm)	GPRS 1 TX Slot (dBm)	GPRS 2 TX Slot (dBm)
GSM 850	128	23.09	23.09	23.63
	190	22.78	22.81	23.39
	251	23.04	23.04	23.66
GSM 1900	512	20.37	20.39	22.27
	661	19.97	19.94	20.97
	810	19.88	19.90	20.73

**Note:**

Time slot average factor is as follows:

1 Tx slot = 9.03 dB, Frame-Average output power = Burst-Average output power – 9.03 dB

2 Tx slot = 6.02 dB, Frame-Average output power = Burst-Average output power – 6.02 dB

GSM Class : B  
 GSM voice/GPRS VOIP: Head SAR , Body worn SAR  
 GPRS Multi-slots 10 : Hotspot SAR with GPRS  
 Multi-slot Class 10 with CS 1 (GMSK)



## 9.2 UMTS

### Release 99 Setup Procedures used to establish the test signals

The following tests were completed according to the test requirements outlined in section 5.2 of the 3GPP TS34.121-1 specification. The DUT supports power Class 3, which has a nominal maximum output power of 24 dBm (+1.7/-3.7)

Mode	Subtest	Rel99
WCDMA General Settings	Loopback Mode	Test Mode 2
	Rel99 RMC	12.2kbps RMC
	Power Control Algorithm	Algorithm2
	$\beta_c/\beta_d$	8/15

### HSDPA Setup Procedures used to establish the test signals

The following 4 Sub-tests were completed according to Release 5 procedures in section 5.2 of 3GPP TS34.121. A summary of these settings are illustrated below:

	Mode	HSDPA			
	Subtest	1	2	3	4
WCDMA General Settings	Loopback Mode	Test Mode 1			
	Rel99 RMC	12.2kbps RMC			
	HSDPA FRC	H-Set 1			
	Power Control Algorithm	Algorithm 2			
	$\beta_c$	2/15	11/15	15/15	15/15
	$\beta_d$	15/15	15/15	8/15	4/15
	Bd (SF)	64			
	$\beta_c/\beta_d$	2/15	12/15	15/8	15/4
	$\beta_{hs}$	4/15	24/15	30/15	30/15
	MPR (dB)	0	0	0.5	0.5
HSDPA Specific Settings	DACK	8			
	DNAK	8			
	DCQI	8			
	Ack-Nack repetition factor	3			
	CQI Feedback (Table 5.2B.4)	4ms			
	CQI Repetition Factor (Table 5.2B.4)	2			
	$A_{hs}=\beta_{hs}/\beta_c$	30/15			

**HSPA (HSDPA & HSUPA) Setup Procedures used to establish the test signals**

The following 5 Sub-tests were completed according to Release 6 procedures in section 5.2 of 3GPP TS34.121. A summary of these settings are illustrated below:

Mode	HSPA					
	Subtest	1	2	3	4	5
WCDMA General Settings	Loopback Mode	Test Mode 1				
	Rel99 RMC	12.2 kbps RMC				
	HSDPA FRC	H-Set 1				
	HSUPA Test	HSPA				
	Power Control Algorithm	Algorithm 2				Algorithm 1
	$\beta_c$	11/15	6/15	15/15	2/15	15/15
	$\beta_d$	15/15	15/15	9/15	15/15	0
	$\beta_{ec}$	209/225	12/15	30/15	2/15	5/15
	$\beta_c/\beta_d$	11/15	6/15	15/9	2/15	15/1
	$\beta_{hs}$	22/15	12/15	30/15	4/15	5/15
	$\beta_{ed}$	1309/225	94/75	47/15	56/75	47/15
CM (dB)	1	3	2	3	1	
MPR (dB)	0	2	1	2	0	
HSDPA Specific Settings	DACK	8				0
	DNAK	8				0
	DCQI	8				0
	Ack-Nack repetition factor	3				
	CQI Feedback (Table 5.2B.4)	4ms				
	CQI Repetition Factor (Table 5.2B.4)	2				
	$A_{hs} = \beta_{hs}/\beta_c$	30/15				
HSUPA Specific Settings	E-DPDCCH	6	8	8	5	7
	DHARQ	0	0	0	0	0
	AG Index	20	12	15	17	21
	ETFCI (from 34.121 Table C.11.1.3)	75	67	92	71	81
	Associated Max UL Data Rate kbps	242.1	174.9	482.8	205.8	308.9
	Reference E-TFCIs	5	5	2	5	1
	Reference E-TFCI	11	11	11	11	67
	Reference E-TFCI PO	4	4	4	4	18
	Reference E-TFCI	67	67	92	67	67
	Reference E-TFCI PO	18	18	18	18	18
	Reference E-TFCI	71	71	71	71	71
	Reference E-TFCI PO	23	23	23	23	23
	Reference E-TFCI	75	75	75	75	75
	Reference E-TFCI PO	26	26	26	26	26
	Reference E-TFCI	81	81	81	81	81
Reference E-TFCI PO	27	27	27	27	27	
Maximum Channelization Codes	2xSF2				SF4	

**HSPA+**

This DUT is only capable of QPSK HSPA+ in uplink. Therefore, the RF conducted power is not measured according to 941225 D01 3G SAR.

WCDMA850 (Maximum Conducted Power)

3GPP Release Version	Mode	3GPP 34.121	WCDMA Band 5 [dBm]		
		Subtest	UL 4132 DL 4357	UL 4183 DL 4408	UL 4233 DL 4458
99	WCDMA	12.2 kbps RMC	22.96	23.11	23.08
99	WCDMA	12.2 kbps AMR	23.02	22.06	23.08
5	HSDPA	Subtest 1	22.86	23.02	23.00
5		Subtest 2	22.86	22.92	22.88
5		Subtest 3	22.88	22.97	22.89
5		Subtest 4	21.82	21.89	21.77
6	HSUPA	Subtest 1	20.69	20.75	20.71
6		Subtest 2	18.78	18.84	18.79
6		Subtest 3	19.72	19.79	19.75
6		Subtest 4	18.77	18.83	18.80
6		Subtest 5	21.69	21.81	21.74
8	DC-HSDPA	Subtest 1	22.89	23.09	22.92
8		Subtest 2	22.87	22.93	22.75
8		Subtest 3	21.83	21.90	21.67
8		Subtest 4	21.84	21.86	21.73

WCDMA Average Conducted output powers

WCDMA1900 (Maximum Conducted Power)

3GPP Release Version	Mode	3GPP 34.121	WCDMA Band 2 [dBm]		
		Subtest	UL 9262 DL 9662	UL 9400 DL 9800	UL 9538 DL 9938
99	WCDMA	12.2 kbps RMC	21.88	21.78	21.77
99	WCDMA	12.2 kbps AMR	22.47	20.78	21.83
5	HSDPA	Subtest 1	21.88	21.82	21.86
5		Subtest 2	21.64	21.56	21.52
5		Subtest 3	21.42	21.40	21.54
5		Subtest 4	21.14	21.11	21.15
6	HSUPA	Subtest 1	19.92	19.88	19.86
6		Subtest 2	18.01	17.93	17.86
6		Subtest 3	19.00	18.95	18.91
6		Subtest 4	18.02	17.92	17.84
6		Subtest 5	20.93	20.84	20.96
8	DC-HSDPA	Subtest 1	21.47	21.19	21.70
8		Subtest 2	21.55	21.24	21.72
8		Subtest 3	21.61	21.26	21.68
8		Subtest 4	21.57	21.29	21.65

WCDMA Average Conducted output powers

### 9.3 LTE

- LTE TDD Band 41 Maximum Conducted Power

Bandwidth	Modulation	RB Size	RB Offset	Max.Average Power (dBm)			MPR Allowed Per 3GPP	MPR
				40265	40740	41215	[dB]	[dB]
				2557.5 MHz	2605 MHz	2652.5 MHz		
5 MHz	QPSK	1	0	23.75	23.77	23.56	0	0
		1	12	23.72	23.71	23.52	0	0
		1	24	23.76	23.72	23.51	0	0
		12	0	22.68	22.78	22.58	0-1	1
		12	6	22.64	22.79	22.57	0-1	1
		12	11	22.66	22.78	22.56	0-1	1
	16QAM	25	0	22.68	22.77	22.56	0-1	1
		1	0	22.74	22.70	22.69	0-1	1
		1	12	22.72	22.67	22.62	0-1	1
		1	24	22.73	22.67	22.59	0-1	1
		12	0	21.56	21.78	21.47	0-2	2
		12	6	21.59	21.75	21.45	0-2	2
		12	11	21.59	21.74	21.46	0-2	2
		25	0	21.59	21.79	21.56	0-2	2

Bandwidth	Modulation	RB Size	RB Offset	Max.Average Power (dBm)			MPR Allowed Per 3GPP	MPR
				40290	40740	41190	[dB]	[dB]
				2560 MHz	2605 MHz	2650 MHz		
10 MHz	QPSK	1	0	23.89	23.89	23.66	0	0
		1	24	23.86	23.84	23.62	0	0
		1	49	23.84	23.80	23.58	0	0
		25	0	22.72	22.81	22.58	0-1	1
		25	12	22.68	22.77	22.55	0-1	1
		25	24	22.70	22.78	22.52	0-1	1
	16QAM	50	0	22.71	22.77	22.55	0-1	1
		1	0	22.72	22.97	22.9	0-1	1
		1	24	22.68	22.93	22.92	0-1	1
		1	49	22.67	22.90	22.89	0-1	1
		25	0	21.62	21.81	21.57	0-2	2
		25	12	21.57	21.78	21.53	0-2	2
		25	24	21.55	21.77	21.50	0-2	2
		50	0	21.69	21.73	21.55	0-2	2

Bandwidth	Modulation	RB Size	RB Offset	Max.Average Power (dBm)			MPR Allowed Per 3GPP	MPR
				40315	40620	41165	[dB]	[dB]
				2562.5 MHz	2593 MHz	2647.5 MHz		
15 MHz	QPSK	1	0	23.93	23.99	23.63	0	0
		1	36	23.92	23.94	23.55	0	0
		1	74	23.82	23.85	23.44	0	0
		36	0	22.79	22.78	22.63	0-1	1
		36	18	22.78	22.74	22.58	0-1	1
		36	39	22.76	22.70	22.54	0-1	1
	16QAM	75	0	22.77	22.75	22.56	0-1	1
		1	0	22.95	22.83	22.84	0-1	1
		1	36	22.93	22.79	22.78	0-1	1
		1	74	22.85	22.68	22.62	0-1	1
		36	0	21.78	21.74	21.62	0-2	2
		36	18	21.77	21.70	21.57	0-2	2
		36	39	21.71	21.67	21.50	0-2	2
		75	0	21.71	21.72	21.52	0-2	2

Bandwidth	Modulation	RB Size	RB Offset	Max.Average Power (dBm)			MPR Allowed Per 3GPP	MPR
				40340	40740	41140	[dB]	[dB]
				2565 MHz	2605 MHz	2645 MHz		
20 MHz	QPSK	1	0	23.97	23.66	23.77	0	0
		1	49	23.96	23.84	23.66	0	0
		1	99	23.86	23.76	23.51	0	0
		50	0	22.95	22.87	22.66	0-1	1
		50	25	22.89	22.80	22.58	0-1	1
		50	49	22.85	22.76	22.51	0-1	1
		100	0	22.91	22.82	22.60	0-1	1
	16QAM	1	0	22.89	22.92	22.87	0-1	1
		1	49	22.87	22.82	22.90	0-1	1
		1	99	22.77	22.73	22.74	0-1	1
		50	0	21.86	21.84	21.61	0-2	2
		50	25	21.85	21.81	21.54	0-2	2
		50	49	21.81	21.78	21.50	0-2	2
		100	0	21.83	21.77	21.57	0-2	2

**Note;**

The EUT enables maximum power reduction in accordance with 3GPP 36.101. The MPR settings are configured during the manufacture process and are not configurable by the network, carrier, or end user.

**LTE Carrier Aggregation**

This device supports intra-band LTE Carrier Aggregation (CA) in the downlink only. All uplink communications are identical to Release 8 specifications. Per FCC KDB Publication 941225 D05A v01r02, SAR for LTE CA operations was not needed since the maximum average output power in LTE CA mode was not >0.25 dB higher than the maximum output power when downlink carrier aggregation was inactive.

**Downlink Carrier Aggregation**

LTE Carrier Aggregation (CA) measurement are made in accordance to 3GPP TS 36.521-1 V10.4.0(2012-12). The RRC connection is only handled by one cell, the Primary component carrier(PCC) for downlink and uplink communications. After making a data connection to the PCC, the UE device adds the Secondary component carrier (SCC) on the downlink only. All uplink communications and acknowledgements remain identical to release 8 specifications on the PCC. Additional output powers are measured using two carriers in the downlink for the release 8 configurations with the highest output power among all channels, RB configurations and bandwidths for each uplink band. Per FCC KDB Publication 941225 D05A v01r02, no SAR measurements are required when the average output power with downlink carrier aggregation active is not more than 0.25 dB higher than the average output power with downlink carrier aggregation inactive.

**LTE Carrier Aggregation Conducted Powers**

PCC(2565 MHz / ch 40340)+ SCC(2643.5MHz / ch 41125	PCC UL#RB	PCC UL RB offset	LTE Rel 10 Tx Power (dBm)	LTE Rel 8 Tx Power (dBm)
	1	0	23.69	23.97

Band 41(PCC) 20 MHz BW + Band 41 (SCC) 20 MHz BW

LTE Carrier Aggregation Conducted Powers

Note:

1. The device does not support all Release 10 Carrier Aggregation features due to modem chipset limitation.
2. The device only support downlink Carrier Aggregation. Uplink Carrier Aggregation is not supported. Power measurements were performed with two DL carriers for the Release 8 configuration that had the highest output power (across all bandwidths, channels and RB configurations) for each band.
3. This device supports intra-band CA with 2 carriers (Band 41 + Band 41) with a maximum of 20 MHz of spectrum.
4. All control and acknowledge data is sent on uplink channels that operate identical to release 8 specifications.

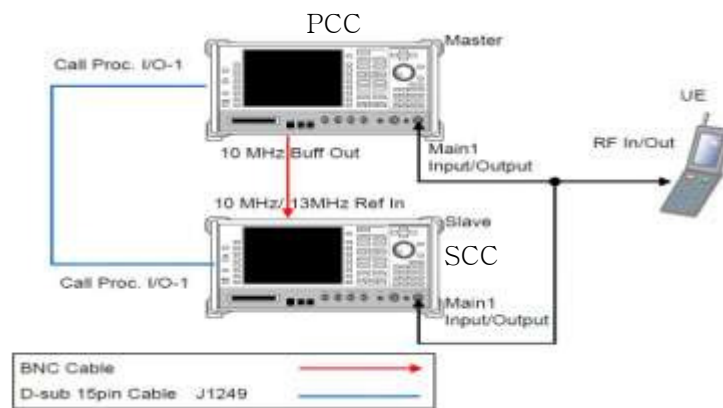

## 9.4 WiFi

**IEEE 802.11 Average RF Power**

Mode	Freq.	Channel	IEEE 802.11 (2.4 GHz) Conducted Power
	[MHz]		[dBm]
802.11b	2412	1	15.36
	2437	6	15.74
	2462	11	15.25
802.11g	2412	1	12.29
	2437	6	12.68
	2462	11	12.29
802.11n	2412	1	11.17
	2437	6	11.50
	2462	11	11.17

Justification for test configurations for WLAN per KDB Publication 248227 D01v02r02:

- Power measurements were performed for the transmission mode configuration with the highest maximum output power specified for production units.
- For transmission mode with the same maximum output power specification, powers were measured for the largest channel bandwidth, lowest order modulation and lowest data rate.
- For transmission modes with identical maximum specified output power, channel bandwidth, modulation and data rates, power measurements were required for all identical configurations.
- For each transmission mode configuration, powers were measured for the highest and lowest channels; and at the mid-band channel(s) when there were at least 3 channels supported. For configurations with multiple mid-band channels, due to an even number of channels, both channels were measured.
- Output power and SAR measurement is not required for 802.11n HT40 channels when the specified tune-up tolerances for 802.11n HT40 are lower than 802.11a by more than 1/2dB and the measured SAR is  $\leq 1.2$  W/kg

### Test Configuration

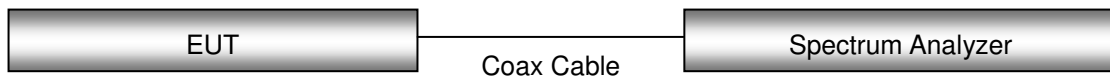

# 10. SYSTEM VERIFICATION

## 10.1 Tissue Verification

The Head /body simulating material is calibrated by HCT using the DAKS 3.5 to determine the conductivity and permittivity.

**Table for Head Tissue Verification**

Date of Tests	Tissue Temp	Tissue Type	Freq. (MHz)	Measured Conductivity $\sigma$ (S/m)	Measured Dielectric Constant, $\epsilon$	Target Conductivity $\sigma$ (S/m)	Target Dielectric Constant, $\epsilon$	% dev $\sigma$	% dev $\epsilon$
02/01/2016	20.5	835H	820	0.882	42.956	0.899	41.578	-1.89%	3.31%
			835	0.899	42.700	0.900	41.500	-0.11%	2.89%
			850	0.916	42.537	0.916	41.500	0.00%	2.50%
02/01/2016	22.0	1900H	1 850	1.358	39.516	1.400	40.000	-3.00%	-1.21%
			1 900	1.400	39.300	1.400	40.000	0.00%	-1.75%
			1 910	1.415	39.326	1.400	40.000	1.07%	-1.69%
02/04/2016	21.2	2450H	2 400	1.772	38.399	1.756	39.290	0.91%	-2.27%
			2 450	1.830	38.200	1.800	39.200	1.67%	-2.55%
			2 500	1.891	37.979	1.855	39.140	1.94%	-2.97%
02/02/2016	21.5	2600H	2 500	1.891	37.981	1.855	39.140	1.94%	-2.96%
			2 600	2.000	37.600	1.964	39.010	1.83%	-3.61%
			2 700	2.113	37.388	2.073	38.880	1.93%	-3.84%

**Table for Body Tissue Verification**

Date of Tests	Tissue Temp	Tissue Type	Freq. (MHz)	Measured Conductivity $\sigma$ (S/m)	Measured Dielectric Constant, $\epsilon$	Target Conductivity $\sigma$ (S/m)	Target Dielectric Constant, $\epsilon$	% dev $\sigma$	% dev $\epsilon$
02/02/2016	20.7	835B	820	0.952	54.653	0.969	55.258	-1.75%	-1.09%
			835	0.981	54.400	0.970	55.200	1.13%	-1.45%
			850	1.026	54.233	0.988	55.154	3.85%	-1.67%
02/03/2016	21.0	1900B	1 850	1.488	55.114	1.520	53.300	-2.11%	3.40%
			1 900	1.550	54.900	1.520	53.300	1.97%	3.00%
			1 910	1.554	54.965	1.520	53.300	2.24%	3.12%
02/04/2016	21.2	2450B	2 400	1.870	51.650	1.902	52.770	-1.68%	-2.12%
			2 450	1.920	51.600	1.950	52.700	-1.54%	-2.09%
			2 500	1.996	51.525	2.021	52.640	-1.24%	-2.12%
02/03/2016	21.6	2600B	2 500	1.994	51.514	2.021	52.640	-1.34%	-2.14%
			2 600	2.120	51.000	2.163	52.510	-1.99%	-2.88%
			2 700	2.256	50.761	2.305	52.380	-2.13%	-3.09%

## 10.2 System Verification

Prior to assessment, the system is verified to the  $\pm 10\%$  of the specifications at 835 MHz / 1 900 MHz / 2 450 MHz / 2 600 MHz by using the system Verification kit. (Graphic Plots Attached)

### System Verification Results

Freq.	Date	Probe (S/N)	Dipole (S/N)	Liquid	Amb. Temp.	Liquid Temp.	1 W Target SAR <sub>1g</sub> (SPEAG)	Measured SAR <sub>1g</sub>	1 W Normalized SAR <sub>1g</sub>	Deviation	Limit [%]
[MHz]					[°C]	[°C]	[W/kg]	[W/kg]	[W/kg]	[%]	[%]
835	02/01/2016	3863	4d165	Head	20.7	20.5	9.06	0.921	9.21	+ 1.66	$\pm 10$
835	02/02/2016	3863		Body	20.9	20.7	9.47	0.981	9.81	+ 3.59	$\pm 10$
1 900	02/01/2016	3967	5d032	Head	22.3	22.0	41.1	4.16	41.6	+ 1.22	$\pm 10$
1 900	02/03/2016	3863		Body	21.2	21.0	40.9	4.08	40.8	- 0.24	$\pm 10$
2 450	02/04/2016	3967	743	Head	21.7	21.2	53.4	5.4	54	+ 1.12	$\pm 10$
2 450	02/04/2016	3967		Body	21.7	21.2	52.1	5.43	54.3	+ 4.22	$\pm 10$
2 600	02/02/2016	3967	1015	Head	21.8	21.5	56.5	5.71	57.1	+ 1.06	$\pm 10$
2 600	02/03/2016	3967		Body	22.0	21.6	55.4	5.54	55.4	+ 0.00	$\pm 10$

## 10.3 System Verification Procedure

SAR measurement was prior to assessment, the system is verified to the  $\pm 10\%$  of the specifications at each frequency band by using the system Verification kit. (Graphic Plots Attached)

- Cabling the system, using the Verification kit equipments.
- Generate about 100 mW Input Level from the Signal generator to the Dipole Antenna.
- Dipole Antenna was placed below the Flat phantom.
- The measured one-gram SAR at the surface of the phantom above the dipole feed-point should be within 10 % of the target reference value.
- The results are normalized to 1 W input power.

### NOTE;

SAR Verification was performed according to the FCC KDB 865664 D01v01r04.

## 11. SAR TEST DATA SUMMARY

### 11.1 HEAD SAR Measurement Results

GSM 850 Head SAR											
Frequency		Mode	Tune-Up Limit	Meas. Power	Power Drift	Test Position	Duty Cycle	Meas. SAR	Scaling Factor	Scaled SAR	Plot No.
MHz	Ch.										
836.6	190	Voice	33.0	31.81	0.10	Left Cheek	1:8.3	0.039	1.315	0.051	-
836.6	190	Voice	33.0	31.81	-0.193	Left Tilt	1:8.3	0.028	1.315	0.037	-
836.6	190	Voice	33.0	31.81	0.17	Right Cheek	1:8.3	0.059	1.315	<b>0.078</b>	1
836.6	190	Voice	33.0	31.81	-0.17	Right Tilt	1:8.3	0.023	1.315	0.030	-
ANSI/ IEEE C95.1 - 2005 – Safety Limit Spatial Peak Uncontrolled Exposure/ General Population						Head 1.6 W/kg (mW/g) Averaged over 1 gram					

GSM 1900 Head SAR											
Frequency		Mode	Tune-Up Limit	Meas. Power	Power Drift	Test Position	Duty Cycle	Meas. SAR	Scaling Factor	Scaled SAR	Plot No.
MHz	Ch.										
1 880.0	661	Voice	29.5	29.00	0.120	Left Cheek	1:8.3	0.112	1.122	<b>0.126</b>	2
1 880.0	661	Voice	29.5	29.00	0.140	Left Tilt	1:8.3	0.063	1.122	0.071	-
1 880.0	661	Voice	29.5	29.00	-0.178	Right Cheek	1:8.3	0.105	1.122	0.118	-
1 880.0	661	Voice	29.5	29.00	0.037	Right Tilt	1:8.3	0.062	1.122	0.070	-
ANSI/ IEEE C95.1 - 2005 – Safety Limit Spatial Peak Uncontrolled Exposure/ General Population						Head 1.6 W/kg (mW/g) Averaged over 1 gram					

UMTS 850 Head SAR											
Frequency		Mode	Tune-Up Limit	Meas. Power	Power Drift	Test Position	Duty Cycle	Meas. SAR	Scaling Factor	Scaled SAR	Plot No.
MHz	Ch.										
836.6	4183	RMC	23.5	23.11	-0.140	Left Cheek	1:1	0.083	1.094	<b>0.091</b>	3
836.6	4183	RMC	23.5	23.11	-0.047	Left Tilt	1:1	0.055	1.094	0.060	-
836.6	4183	RMC	23.5	23.11	-0.136	Right Cheek	1:1	0.066	1.094	0.072	-
836.6	4183	RMC	23.5	23.11	0.008	Right Tilt	1:1	0.051	1.094	0.056	-
ANSI/ IEEE C95.1 - 2005 – Safety Limit Spatial Peak Uncontrolled Exposure/ General Population						Head 1.6 W/kg (mW/g) Averaged over 1 gram					

**UMTS 1900 Head SAR**

Frequency		Mode	Tune-Up Limit	Meas. Power	Power Drift	Test Position	Duty Cycle	Meas. SAR	Scaling Factor	Scaled SAR	Plot No.
MHz	Ch.										
1 880.0	9400	RMC	22.0	21.78	-0.180	Left Cheek	1:1	0.166	1.052	<b>0.175</b>	4
1 880.0	9400	RMC	22.0	21.78	-0.022	Left Tilt	1:1	0.104	1.052	0.109	-
1 880.0	9400	RMC	22.0	21.78	0.161	Right Cheek	1:1	0.153	1.052	0.161	-
1 880.0	9400	RMC	22.0	21.78	0.069	Right Tilt	1:1	0.099	1.052	0.104	-
ANSI/ IEEE C95.1 - 2005 – Safety Limit Spatial Peak Uncontrolled Exposure/ General Population						Head 1.6 W/kg (mW/g) Averaged over 1 gram					

**LTE Band 41 Head SAR**

Frequency		Mode	Band width	Tune-Up Limit	Meas. Power	Power Drift	Test Position	RB Size	RB offset	Duty Cycle	Meas. SAR	Scaling Factor	Scaled SAR	Plot No.
MHz	Ch.													
2 565	40340	QPSK	20	24.0	23.97	0.15	Left Cheek	1	0	1:1.58	0.064	1.007	0.064	-
2 565	40340	QPSK	20	23.0	22.95	0.13	Left Cheek	50	0	1:1.58	0.048	1.012	0.049	-
2 565	40340	QPSK	20	24.0	23.97	0.1	Left Tilt	1	0	1:1.58	0.017	1.007	0.017	-
2 565	40340	QPSK	20	23.0	22.95	0.1	Left Tilt	50	0	1:1.58	0.013	1.012	0.013	-
2 565	40340	QPSK	20	24.0	23.97	0.10	Right Cheek	1	0	1:1.58	0.065	1.007	<b>0.065</b>	5
2 565	40340	QPSK	20	23.0	22.95	0.16	Right Cheek	50	0	1:1.58	0.048	1.012	0.049	-
2 565	40340	QPSK	20	24.0	23.97	-0.17	Right Tilt	1	0	1:1.58	0.022	1.007	0.022	-
2 565	40340	QPSK	20	23.0	22.95	0.1	Right Tilt	50	0	1:1.58	0.024	1.012	0.024	-
ANSI/ IEEE C95.1 - 2005– Safety Limit Spatial Peak Uncontrolled Exposure/ General Population						Head 1.6 W/kg (mW/g) Averaged over 1 gram								

**DTS Head SAR**

Frequency		Mode	Band width	Data Rate	Tune-Up Limit	Meas. Power	Power Drift	Test Position	Duty Cycle	Area Scan Peak SAR	Meas. SAR	Scaling Factor	Scaling Factor	Scaled SAR	Plot No.
MHz	Ch.														
2 437	6	802.11b	22	1	16.5	15.74	-0.18	Left Cheek	99.08	1.06	0.664	1.191	1.009	<b>0.798</b>	6
2 437	6	802.11b	22	1	16.5	15.74	0.003	Left Tilt	99.08	0.784	0.506	1.191	1.009	0.608	-
2 437	6	802.11b	22	1	16.5	15.74	0.150	Right Cheek	99.08	0.359	0.251	1.191	1.009	0.302	-
2 437	6	802.11b	22	1	16.5	15.74		Right Tilt	99.08	0.297		1.191	1.009		-
ANSI/ IEEE C95.1 - 2005 – Safety Limit Spatial Peak Uncontrolled Exposure/ General Population						Head 1.6 W/kg (mW/g) Averaged over 1 gram									

## 11.2 Body-worn SAR Measurement Results

GSM/UMTS Body-Worn SAR												
Frequency		Mode	Tune-Up Limit	Meas. Power	Power Drift	Test Position	Duty Cycle	Distance	Meas. SAR	Scaling Factor	Scaled SAR	Plot No.
MHz	Ch.											
836.6	190	Voice	33.0	31.81	-0.041	Rear	1:8.3	15	0.133	1.315	0.175	-
836.6	190	Voice	33.0	31.81	0.001	Front	1:8.3	15	0.152	1.315	<b>0.200</b>	7
1 880.0	661	Voice	29.5	29.00	-0.044	Rear	1:8.3	15	0.159	1.122	0.178	-
1 880.0	661	Voice	29.5	29.00	-0.041	Front	1:8.3	15	0.199	1.122	<b>0.223</b>	8
836.6	4183	RMC	23.5	23.11	0.162	Rear	1:1	15	0.155	1.094	0.170	-
836.6	4183	RMC	23.5	23.11	-0.045	Front	1:1	15	0.189	1.094	<b>0.207</b>	9
1 880.0	9400	RMC	22.0	21.78	-0.039	Rear	1:1	15	0.295	1.052	0.310	-
1 880.0	9400	RMC	22.0	21.78	-0.046	Front	1:1	15	0.348	1.052	<b>0.366</b>	10
ANSI/ IEEE C95.1 - 2005 – Safety Limit Spatial Peak Uncontrolled Exposure/ General Population						Head 1.6 W/kg (mW/g) Averaged over 1 gram						

LTE Body-Worn SAR															
Frequency		Mode	Band width	Tune-Up Limit	Meas. Power	Power Drift	Test Position	RB Size	RB offset	Duty Cycle	Distance	Meas. SAR	Scaling Factor	Scaled SAR	Plot No.
MHz	Ch.														
2 565	40340	QPSK	20	24.0	23.97	0.12	Rear	1	0	1:1.58	15	0.329	1.007	0.331	-
2 565	40340	QPSK	20	23.0	22.95	0.15	Rear	50	0	1:1.58	15	0.250	1.012	0.253	-
2 565	40340	QPSK	20	24.0	23.97	0.15	Front	1	0	1:1.58	15	0.353	1.007	<b>0.355</b>	11
2 565	40340	QPSK	20	23.0	22.95	0.141	Front	50	0	1:1.58	15	0.268	1.012	0.271	-
ANSI/ IEEE C95.1 - 2005 – Safety Limit Spatial Peak Uncontrolled Exposure/ General Population							Head 1.6 W/kg (mW/g) Averaged over 1 gram								

DTS Body-Worn SAR																
Frequency		Mode	Band width	Data Rate	Tune-Up Limit	Meas. Power	Power Drift	Test Position	Duty Cycle	Distance	Area Scan Peak SAR	Meas. SAR	Scaling Factor	Scaling Factor (Duty)	Scaled SAR	Plot No.
MHz	Ch.															
2 437	6	802.11b	22	1	16.5	15.74	0.126	Rear	99.08	15	0.079	0.038	1.191	1.009	0.046	-
2 437	6	802.11b	22	1	16.5	15.74	0.124	Front	99.08	15	0.097	0.046	1.191	1.009	<b>0.055</b>	12
ANSI/ IEEE C95.1 - 2005 – Safety Limit Spatial Peak Uncontrolled Exposure/ General Population								Head 1.6 W/kg (mW/g) Averaged over 1 gram								

### 11.3 Hotspot SAR Measurement Results

GSM 850 Hotspot SAR												
Frequency		Mode	Tune-Up Limit	Meas. Power	Power Drift	Test Position	Duty Cycle	Distance	Meas. SAR	Scaling Factor	Scaled SAR	Plot No.
MHz	Ch.											
836.6	190	GPRS 2Tx	30.0	29.41	0.128	Rear	1:4.15	10	0.170	1.146	0.195	-
836.6	190	GPRS 2Tx	30.0	29.41	-0.010	Front	1:4.15	10	0.191	1.146	0.219	-
836.6	190	GPRS 2Tx	30.0	29.41	0.126	Left	1:4.15	10	0.044	1.146	0.050	-
836.6	190	GPRS 2Tx	30.0	29.41	-0.002	Right	1:4.15	10	0.100	1.146	0.115	-
836.6	190	GPRS 2Tx	30.0	29.41	0.022	Bottom	1:4.15	10	0.192	1.146	<b>0.220</b>	13
ANSI/ IEEE C95.1 - 2005 – Safety Limit Spatial Peak Uncontrolled Exposure/ General Population						Body 1.6 W/kg (mW/g) Averaged over 1 gram						

GSM 1900 Hotspot SAR												
Frequency		Mode	Tune-Up Limit	Meas. Power	Power Drift	Test Position	Duty Cycle	Distance	Meas. SAR	Scaling Factor	Scaled SAR	Plot No.
MHz	Ch.											
1 850.2	512	GPRS 2Tx	28.5	28.29	0.142	Rear	1:4.15	10	0.481	1.050	0.505	-
1 850.2	512	GPRS 2Tx	28.5	28.29	-0.110	Front	1:4.15	10	0.549	1.050	0.576	-
1 850.2	512	GPRS 2Tx	28.5	28.29	-0.154	Left	1:4.15	10	0.193	1.050	0.203	-
1 850.2	512	GPRS 2Tx	28.5	28.29	0.000	Right	1:4.15	10	0.076	1.050	0.080	-
1 850.2	512	GPRS 2Tx	28.5	28.29	-0.049	Bottom	1:4.15	10	0.610	1.050	<b>0.640</b>	14
ANSI/ IEEE C95.1 - 2005 – Safety Limit Spatial Peak Uncontrolled Exposure/ General Population						Body 1.6 W/kg (mW/g) Averaged over 1 gram						

UMTS 850 Hotspot SAR												
Frequency		Mode	Tune-Up Limit	Meas. Power	Power Drift	Test Position	Duty Cycle	Distance	Meas. SAR	Scaling Factor	Scaled SAR	Plot No.
MHz	Ch.											
836.6	4183	RMC	23.5	23.11	-0.123	Rear	1:1	10	0.300	1.094	0.328	-
836.6	4183	RMC	23.5	23.11	-0.056	Front	1:1	10	0.261	1.094	0.286	-
836.6	4183	RMC	23.5	23.11	0.088	Left	1:1	10	0.121	1.094	0.132	-
836.6	4183	RMC	23.5	23.11	0.014	Right	1:1	10	0.075	1.094	0.082	-
836.6	4183	RMC	23.5	23.11	-0.006	Bottom	1:1	10	0.559	1.094	<b>0.612</b>	15
ANSI/ IEEE C95.1 - 2005 – Safety Limit Spatial Peak Uncontrolled Exposure/ General Population						Body 1.6 W/kg (mW/g) Averaged over 1 gram						

**UMTS 1900 Hotspot SAR**

Frequency		Mode	Tune-Up Limit	Meas. Power	Power Drift	Test Position	Duty Cycle	Distance	Meas. SAR	Scaling Factor	Scaled SAR	Plot No.
MHz	Ch.		(dB)	(dB)	(dB)						(mm)	
1 880.0	9400	RMC	22.0	21.78	-0.153	Rear	1:1	10	0.536	1.052	0.564	-
1 880.0	9400	RMC	22.0	21.78	-0.062	Front	1:1	10	0.675	1.052	0.710	-
1 880.0	9400	RMC	22.0	21.78	-0.045	Left	1:1	10	0.319	1.052	0.336	-
1 880.0	9400	RMC	22.0	21.78	0.036	Right	1:1	10	0.152	1.052	0.160	-
1 852.4	9262	RMC	22.0	21.88	-0.018	Bottom	1:1	10	0.948	1.028	0.975	-
1 880.0	9400	RMC	22.0	21.78	0.008	Bottom	1:1	10	0.978	1.052	<b>1.029</b>	16
1 907.6	9538	RMC	22.0	21.77	0.136	Bottom	1:1	10	0.968	1.054	1.021	-
ANSI/ IEEE C95.1 - 2005 – Safety Limit Spatial Peak Uncontrolled Exposure/ General Population						Body 1.6 W/kg (mW/g) Averaged over 1 gram						

**LTE Band 41 Hotspot SAR**

Frequency		Mode	Band width	Tune-Up Limit	Meas. Power	Power Drift	Test Position	RB Size	RB offset	Duty Cycle	Distance	Meas. SAR	Scaling Factor	Scaled SAR	Plot No.
MHz	Ch.		(MHz)	(dBm)	(dBm)	(dB)								(mm)	
2 565	40340	QPSK	20	24.0	23.97	-0.161	Rear	1	0	1:1.58	10	0.512	1.007	0.516	-
2 565	40340	QPSK	20	23.0	22.95	0.12	Rear	50	0	1:1.58	10	0.390	1.012	0.395	-
2 565	40340	QPSK	20	24.0	23.97	0.12	Front	1	0	1:1.58	10	0.638	1.007	0.642	-
2 565	40340	QPSK	20	23.0	22.95	0.171	Front	50	0	1:1.58	10	0.478	1.012	0.484	-
2 565	40340	QPSK	20	24.0	23.97	-0.050	Left	1	0	1:1.58	10	0.133	1.007	0.134	-
2 565	40340	QPSK	20	23.0	22.95	0.113	Left	50	0	1:1.58	10	0.105	1.012	0.106	-
2 565	40340	QPSK	20	24.0	23.97	0.138	Right	1	0	1:1.58	10	0.064	1.007	0.064	-
2 565	40340	QPSK	20	23.0	22.95	0.125	Right	50	0	1:1.58	10	0.048	1.012	0.049	-
2 565	40340	QPSK	20	24.0	23.97	-0.022	Bottom	1	0	1:1.58	10	0.921	1.007	0.927	-
2 605	40740	QPSK	20	24.0	23.84	0.019	Bottom	1	49	1:1.58	10	0.994	1.038	1.031	-
2 645	41140	QPSK	20	24.0	23.77	-0.077	Bottom	1	0	1:1.58	10	1.05	1.054	<b>1.107</b>	17
2 565	40340	QPSK	20	23.0	22.95	-0.021	Bottom	50	0	1:1.58	10	0.736	1.012	0.745	-
2 605	40740	QPSK	20	23.0	22.87	0.006	Bottom	50	0	1:1.58	10	0.801	1.030	0.825	-
2 645	41140	QPSK	20	23.0	22.66	-0.028	Bottom	50	0	1:1.58	10	0.837	1.081	0.905	-
2 565	40340	QPSK	20	23.0	22.91	-0.008	Bottom	100	0	1:1.58	10	0.727	1.021	0.742	-
ANSI/ IEEE C95.1 - 2005 – Safety Limit Spatial Peak Uncontrolled Exposure/ General Population						Body 1.6 W/kg (mW/g) Averaged over 1 gram									

DTS Hotspot SAR																
Frequency		Mode	Band width	Data Rate	Tune-Up Limit	Meas. Power	Power Drift	Test Position	Duty Cycle	Distance	Area Scan Peak SAR	Meas. SAR	Scaling Factor	Scaling Factor	Scaled SAR	Plot No.
MHz	Ch.															
2 437	6	802.11b	22	1	16.5	15.74		Rear	99.08	10	0.182		1.191	1.009		-
2 437	6	802.11b	22	1	16.5	15.74	-0.034	Front	99.08	10	0.231	0.106	1.191	1.009	<b>0.127</b>	18
2 437	6	802.11b	22	1	16.5	15.74		Right	99.08	10	0.137		1.191	1.009		-
2 437	6	802.11b	22	1	16.5	15.74		Top	99.08	10	0.159		1.191	1.009		-
ANSI/ IEEE C95.1 - 2005 – Safety Limit Spatial Peak Uncontrolled Exposure/ General Population								Body 1.6 W/kg (mW/g) Averaged over 1 gram								

## 11.4 SAR Test Notes

### General Notes:

1. The test data reported are the worst-case SAR values according to test procedures specified in IEEE 1528-2013, FCC KDB Procedure.
2. Batteries are fully charged at the beginning of the SAR measurements. A standard battery was used for all SAR measurements.
3. Liquid tissue depth was at least 15.0 cm for all frequencies.
4. The manufacturer has confirmed that the device(s) tested have the same physical, mechanical and thermal characteristics and are within operational tolerances expected for production units.
5. SAR results were scaled to the maximum allowed power to demonstrate compliance per FCC KDB 447498 D01v06.
6. Device was tested using a fixed spacing for body-worn accessory testing. A separation distance of 15 mm was considered because the manufacturer has determined that there will be body-worn accessories available in the marketplace for users to support this separation distance.
7. Per FCC KDB 648474 D04v01r03, SAR was evaluated without a headset connected to the device. Since the standalone reported SAR was  $\leq 1.2$  W/kg, no additional SAR evaluation using a headset cable were required.
8. Per KDB 648474 D04v01r03, this device is considered a "Phablet" since the diagonal dimension is  $> 160$  mm and  $< 200$  mm. When hotspot mode applies, extremity SAR is required only for the surfaces and edges with hotspot mode scaled to the maximum output power (with tolerance) is 1 g SAR  $> 1.2$  W/kg.

### GSM/GPRS Test Notes:

1. This EUT'S GSM and GPRS device class is B.
2. Body-Worn accessory testing is typically associated with voice operations. Therefore, GSM voice was evaluated for body-worn SAR.
3. Justification for reduced test configurations per KDB 941225 D01v03r01: The source-based time-averaged output power was evaluated for all multi-slot operations. The multi-slot configuration with the highest frame averaged output power including tolerance was evaluated for SAR.
4. Per FCC KDB 447498 D01v06, if the reported (scaled) SAR measured at the middle channel or highest output power channel for each test configuration is  $\leq 0.8$  W/kg then testing at the other channels is not required for such test configuration(s). When the maximum output power variation across the required test channels is 1/2 dB, instead of the middle channel, the highest output power channel must be used.
5. Justification for reduced test configurations per KDB Publication 941225 D01v03r01 and October 2013 TCB Workshop Notes: The source-based frame-averaged output power was evaluated for all GPRS/EDGE slot configurations. The configuration with the highest target frame averaged output power was evaluated for hotspot SAR. When the maximum frame-averaged powers are equivalent across two or more slots (within 0.25 dB), the configuration with the most number of time slots was tested.

**UMTS Notes:**

1. The 12.2 kbps RMC mode is the primary mode per KDB 941225 D01v03r01.
2. UMTS mode in Body SAR was tested under RMC 12.2 kbps with HSPA inactive per KDB 941225 D01v03r01. HSPA SAR was not required since the average output power of the HSPA subtests was not more than 0.25 dB higher than the RMC level and Adjusted SAR value was less than 1.2 W/kg.
3. Per FCC KDB 447498 D01v06, if the reported (scaled) SAR measured at the middle channel or highest output power channel for each test configuration is  $\leq 0.8$  W/kg then testing at the other channels is not required for such test configuration(s). When the maximum output power variation across the channel highest output power channel was used.
4. UMTS SAR was tested under RMC 12.2 kbps with HSPA inactive per KDB publication 941225 D01v03r01. HSPA SAR was not required since the average output power of the HSPA subtests was not more than 0.25 dB higher than the RMC level and SAR was less than 1.2 W/kg.

**LTE Notes:**

1. LTE Considerations: LTE test configurations are determined according to SAR Evaluation Consideration for LTE Devices in FCC KDB 941225 D05v02r05.
2. According to FCC KDB 941225 D05v02r05:  
When the reported SAR is  $\leq 0.8$  W/kg, testing of the 100%RB allocation and required test channels is not required. Otherwise, SAR is required for the remaining required test channels using the 1RB, 50%RB and 100%RB allocation with highest output power for that channel.  
Only one channel, and as reported SAR values for 1RB allocation and 50%RB allocation were less than 1.45W/Kg only the highest power RB offset for each allocation was required.
3. MPR is permanently implemented for this device by the manufacturer. The specific manufacturer target MPR is indicated alongside the SAR results. MPR is enabled for this device, according to target MPR is indicated alongside the SAR results.
4. A-MPR was disabled for all SAR tests by setting NS=01 on the base station simulator.
5. Pre-installed VOIP applications are considered.
6. TDD LTE was tested using UL-DL configuration 0 with 6 UL subframes and 2S subframes using extended cyclic prefix only and special subframe configuration 6. SAR tests were performed at maximum output power and worst-case transmission duty factor in extended cyclic prefix. Per 3GPP 36.211 Sec. 4, the duty factor using extended cyclic prefix is 0.633(cf=1.58).
7. Per KDB 941225 D05Av01r02, SAR for LTE Carrier Aggregation operations was not needed because the maximum average output power in LTE CA mode was not  $> 0.25$  dB higher than the maximum output power when downlink CA was not activated.
8. SAR test reduction is applied using the following criteria:  
Start with the largest channel bandwidth and measure SAR for QPSK with 1 RB, and 50% RB allocation, using the RB offset and required test channel combination with the highest maximum output power among RB offsets at the upper edge, middle and lower edge of each required test channel. When the reported SAR is  $>0.8$  W/kg, testing for other Channels is performed at the highest output power level for 1RB, and 50% RB configuration for that channel. Testing for 100% RB configuration is performed at the highest output power level for 100% RB configuration across the Low, Mid and High Channel when the highest reported SAR for 1 RB and 50% RB are  $>0.8$  W/kg, Testing for the remaining required channels is not needed because the reported SAR for 100% RB Allocation  $<1.45$  W/kg. Testing for 16-QAM modulation is not required because the reported SAR for QPSK is  $<1.45$  W/kg and its output power is not more than 0.5 dB higher than that a QPSK. Testing for the other channel bandwidths is not required because the reported SAR for the highest channel bandwidth is  $<1.45$  W/kg and its output power is not more than 0.5 dB higher than that of the highest channel bandwidth.

**WLAN Notes:**

1. For held-to-ear and hotspot operations, the initial test position procedures were applied. For initial test position, the highest extrapolated peak SAR will be used. When reported SAR for the initial test position is  $\leq 0.4$  W/kg for 1g SAR and  $\leq 1.0$  W/kg for 10g SAR, no additional testing for the remaining test positions was required. Otherwise, SAR is evaluated at the subsequent highest peak SAR positions until the reported SAR results is  $\leq 0.8$  W/kg for 1g SAR and  $\leq 2.0$  W/kg for 10g SAR or all test position are measured.
2. Per KDB 248227 D01v02r02 justification for test configurations of 2.4 GHz WiFi Single transmission chain operations, the highest measured maximum output power channel for DSSS was selected for SAR measurement. SAR for OFDM modes (2.4 GHz 802.11 g/n) was not required due to the maximum allowed powers and the highest reported DSSS SAR.
3. When the maximum reported 1g averaged SAR is  $\leq 0.8$  W/kg, SAR testing on additional channels was not required. Otherwise, SAR for the next highest output power channel was required until the reported SAR result was  $\leq 1.20$  W/kg or all test channels were measured.
4. The device was configured to transmit continuously at the required data rated, channel bandwidth and signal modulation, using the highest transmission duty factor supported by the test mode tools. The reported SAR was scaled to the 100% transmission duty factor to determine compliance. Procedures used to measure the duty factor are identical to that in the associated WLAN test reports.

## 12. Simultaneous SAR Analysis

### 12.1 Simultaneous Transmission Summation for Head

Simultaneous Transmission Summation Scenario with 2.4 GHz WLAN				
Exposure condition	Band	WWAN SAR	2.4 GHz WLAN SAR	$\sum$ 1-g SAR
		(W/kg)	(W/kg)	(W/kg)
Head SAR	GSM 850	0.078	0.798	0.876
	GSM 1900	0.126	0.798	0.924
	UMTS 850	0.091	0.798	0.889
	UTMS 1900	0.175	0.798	<b>0.973</b>
	LTE Band 41	0.065	0.798	0.863

### 12.2 Simultaneous Transmission Summation for Body-Worn

Simultaneous Transmission Summation Scenario with 2.4 GHz WLAN					
Exposure condition	Distance	Band	WWAN SAR	2.4 GHz WLAN SAR	$\sum$ 1-g SAR
	(mm)		(W/kg)	(W/kg)	(W/kg)
Body-worn	15	GSM 850	0.200	0.055	0.255
		GSM 1900	0.223	0.055	0.278
		UMTS 850	0.207	0.055	0.262
		UTMS 1900	0.366	0.055	0.421
		LTE Band 41	0.355	0.055	0.410

Simultaneous Transmission Summation Scenario with Bluetooth					
Exposure condition	Distance	Band	WWAN SAR	Bluetooth Estimated SAR	$\sum$ 1-g SAR
	(mm)		(W/kg)	(W/kg)	(W/kg)
Body-worn	15	GSM 850	0.200	0.13	0.330
		GSM 1900	0.223	0.13	0.353
		UMTS 850	0.207	0.13	0.337
		UTMS 1900	0.366	0.13	0.496
		LTE Band 41	0.355	0.13	0.485

Note:

1. Bluetooth SAR was not required to be measured per FCC KDB 447498 D01v06. Estimated SAR results were used for SAR summation for body-worn back side at 15 mm to determine simultaneous transmission SAR test exclusion.

### 12.3 Simultaneous Transmission Summation for Hotspot

Simultaneous Transmission Summation Scenario with 2.4 GHz WLAN					
Exposure condition	Distance	Band	WWAN SAR	2.4 GHz WLAN SAR	$\Sigma$ 1-g SAR
	(mm)		(W/kg)	(W/kg)	(W/kg)
Hotspot	10	GSM 850	0.220	0.127	0.347
		GSM 1900	0.640	0.127	0.767
		UMTS 850	0.612	0.127	0.739
		UTMS 1900	1.029	0.127	1.156
		LTE Band 41	1.107	0.127	<b>1.234</b>

### 12.4 Simultaneous Transmission Conclusion

The above numerical summed SAR results for all the worst-case simultaneous transmission conditions were below the SAR limit. Therefore, the above analysis is sufficient to determine that simultaneous transmission cases will not exceed the SAR limit. And therefore no measured volumetric simultaneous SAR summation is required per FCC KDB Publication 447498 D01v06 and IEEE 1528-2013.

### 13. SAR Measurement Variability and Uncertainty

In accordance with KDB procedure 865664 D01v01r04 SAR measurement 100 MHz to 6 GHz, SAR additional measurements are repeated after the completion of all measurements requiring the same head or body tissue-equivalent medium in a frequency band. The test device should be returned to ambient conditions (normal room temperature) with the battery fully charged before it is re-mounted on the device holder for the repeated measurement(s) to minimize any unexpected variations in the repeated results.

SAR Measurement variability was assessed using the following procedures for each frequency band:

- 1) Repeated measurement is not required when the original highest measured SAR is < 0.80 W/kg for 1g SAR or < 2.0 W/kg for 10g SAR ; steps 2) through 4) do not apply.
- 2) When the original highest measured 1g SAR is  $\geq 0.80$  W/kg or 10g SAR  $\geq 2.0$ W/kg, repeat that measurement once.
- 3) Perform a second repeated measurement only if the ratio of largest to smallest SAR for the original and first repeated measurements is > 1.20 or when the original or repeated measurement is  $\geq 1.45$  W/kg for 1g SAR or  $\geq 3.625$  W/kg for 10g SAR (~ 10% from the 1-g SAR limit).
- 4) Perform a third repeated measurement only if the original, first or second repeated measurement is  $\geq 1.5$  W/kg for 1g SAR or  $\geq 3.75$  W/kg for 10g SAR and the ratio of largest to smallest SAR for the original, first and second repeated measurements is > 1.20.

Frequency		Modulation	Battery	Configuration	Original SAR	Repeated SAR	Largest to Smallest SAR Ratio	Plot No.
MHz	Channel				(W/kg)	(W/kg)		
1 880	9400	UMTS 1900	Standard	Bottom	0.978	0.930	1.05	19
2 645	41140	LTE Band 41	Standard	Bottom (1RB, 0offset)	1.05	1.05	1.00	20

# 14. MEASUREMENT UNCERTAINTY

Uncertainty (700 MHz ~ 5000 MHz)						
Error Description	Tol	Prob.	Div.	C <sub>i</sub>	Standard Uncertainty (± %)	V <sub>eff</sub>
	(± %)	dist.				
<b>1. Measurement System</b>						
Probe Calibration	6.55	N	1	1	6.55	∞
Axial Isotropy	4.70	R	1.73	0.7	1.90	∞
Hemispherical Isotropy	9.60	R	1.73	0.7	3.88	∞
Boundary Effects	1.00	R	1.73	1	0.58	∞
Linearity	4.70	R	1.73	1	2.71	∞
System Detection Limits	1.00	R	1.73	1	0.58	∞
Readout Electronics	0.30	N	1.00	1	0.30	∞
Response Time	0.8	R	1.73	1	0.46	∞
Integration Time	2.6	R	1.73	1	1.50	∞
RF Ambient Conditions	3.00	R	1.73	1	1.73	∞
Probe Positioner	0.40	R	1.73	1	0.23	∞
Probe Positioning	2.90	R	1.73	1	1.67	∞
Max SAR Eval	1.00	R	1.73	1	0.58	∞
<b>2. Test Sample Related</b>						
Device Positioning	2.25	N	1.00	1	2.25	9
Device Holder	3.60	N	1.00	1	3.60	∞
Power Drift	5.00	R	1.73	1	2.89	∞
<b>3. Phantom and Setup</b>						
Phantom Uncertainty	4.00	R	1.73	1	2.31	∞
Liquid Conductivity(target)	5.00	R	1.73	0.64	1.85	∞
Liquid Conductivity(meas.)	3.00	N	1	0.64	1.73	∞
Liquid Permittivity(target)	5.00	R	1.73	0.6	1.73	∞
Liquid Permittivity(meas.)	2.30	N	1	0.6	1.14	∞
<b>Combine Standard Uncertainty</b>					10.99	
<b>Coverage Factor for 95 %</b>					k=2	
<b>Expanded STD Uncertainty</b>					21.98	

## 15. SAR TEST EQUIPMENT

Manufacturer	Type / Model	S/N	Calib. Date	Calib.Interval	Calib.Due
SPEAG	SAM Phantom	-	N/A	N/A	N/A
SPEAG	Triple Modular Phantom	-	N/A	N/A	N/A
HP	SAR System Control PC	-	N/A	N/A	N/A
Staubli	Robot RX90B L	F01/5K09A1/A/01	N/A	N/A	N/A
Staubli	Robot ControllerCS7MB	F01/5K09A1/C/01	N/A	N/A	N/A
SCHMID & PARTNER	Light Alignment Sensor	265	N/A	N/A	N/A
Staubli	Teach Pendant (Joystick)	D221340.01	N/A	N/A	N/A
SPEAG	DAE4	869	10/07/2015	Annual	10/07/2016
SPEAG	DAE4	652	01/22/2016	Annual	01/22/2017
SPEAG	E-Field Probe EX3DV4	3863	08/27/2015	Annual	08/27/2016
SPEAG	E-Field Probe EX3DV4	3967	12/16/2015	Annual	12/16/2016
SPEAG	Dipole D835V2	4d165	11/24/2015	Annual	11/24/2016
SPEAG	Dipole D1900V2	5d032	05/20/2015	Annual	05/20/2016
SPEAG	Dipole D2450V2	743	05/19/2015	Annual	05/19/2016
SPEAG	Dipole D2600V2	1015	03/25/2015	Annual	03/25/2016
Agilent	Power Meter N1991A	MY45101406	10/03/2015	Annual	10/03/2016
Agilent	Power Sensor N1921A	MY55220026	08/19/2015	Annual	08/19/2016
SPEAG	DAKS 3.5	1038	05/26/2015	Annual	05/26/2016
HP	Directional Bridge	86205A	05/20/2015	Annual	05/20/2016
Agilent	Base Station E5515C	GB44400269	02/09/2015	Annual	02/09/2016
HP	Signal Generator N5182A	MY4770230	05/13/2015	Annual	05/13/2016
Agilent	MXA Signal Analyzer N9020A	MY50510407	03/23/2015	Annual	03/23/2016
HP	Network Analyzer 8753ES	JP39240221	03/23/2015	Annual	03/23/2016
R&S	Wideband Radio Communication Tester CMW500	115733	09/18/2015	Annual	09/18/2016
Hewlett Packard	11636B/Power Divider	58698	03/02/2015	Annual	03/02/2016

**NOTE:**

1. The E-field probe was calibrated by SPEAG, by the waveguide technique procedure. Dipole Verification measurement is performed by HCT Lab. before each test. The brain/body simulating material is calibrated by HCT using the DAKS 3.5 to determine the conductivity and permittivity (dielectric constant) of the brain/body-equivalent material.

## 16. CONCLUSION

The SAR measurement indicates that the EUT complies with the RF radiation exposure limits of the ANSI/IEEE C95.1- 2005.

These measurements are taken to simulate the RF effects exposure under worst-case conditions. Precise laboratory measures were taken to assure repeatability of the tests.

The SAR measurement indicates that the EUT complies with the RF radiation exposure limits of the FCC and Industry Canada. These measurements were taken to simulate the RF effects of RF exposure under worst-case conditions. Precise laboratory measures were taken to assure repeatability of the tests. The results and statements relate only to the item(s) tested.

## 17. REFERENCES

- [1] IEEE Standards Coordinating Committee 34 – IEEE Std. 1528-2013, IEEE Recommended Practice or Determining the Peak Spatial-Average Specific Absorption Rate (SAR) in the Human Head from Wireless Communications Devices.
- [2] Federal Communications Commission, ET Docket 93-62, Guidelines for Evaluating the Environmental Effects of Radio frequency Radiation, Aug. 1996.
- [3] ANSI/IEEE C95.1 - 1991, American National Standard safety levels with respect to human exposure to radio frequency electromagnetic fields, 300 kHz to 100 GHz, New York: IEEE, Aug. 1992
- [4] ANSI/IEEE C 95.1 - 2005, American National Standard safety levels with respect to human exposure to radio frequency electromagnetic fields, 3 kHz to 300 GHz, New York: IEEE, 2006.
- [5] ANSI/IEEE C95.3 - 1991, IEEE Recommended Practice for the Measurement of Potentially Hazardous Electromagnetic Fields - RF and Microwave, New York: IEEE, 1992.
- [6] NCRP, National Council on Radiation Protection and Measurements, Biological Effects and Exposure Criteria for Radio Frequency Electromagnetic Fields, NCRP Report No. 86, 1986. Reprinted Feb. 1995.
- [7] T. Schmid, O. Egger, N. Kuster, Automated E-field scanning system for dosimetric assessments, IEEE Transaction on Microwave Theory and Techniques, vol. 44, Jan. 1996, pp. 105-113.
- [8] K. Pokovic, T. Schmid, N. Kuster, Robust setup for precise calibration of E-field probes in tissue simulating liquids at mobile communications frequencies, ICECOM97, Oct. 1997, pp. 120-124.
- [9] K. Pokovic, T. Schmid, and N. Kuster, E-field Probe with improved isotropy in brain simulating liquids, Proceedings of the ELMAR, Zadar, Croatia, June 23-25, 1996, pp. 172-175.
- [10] Schmid & Partner Engineering AG, Application Note: Data Storage and Evaluation, June 1998, p2.
- [11] V. Hombach, K. Meier, M. Burkhardt, E. Kuhn, N. Kuster, The Dependence of EM Energy Absorption upon Human Head Modeling at 900 MHz, IEEE Transaction on Microwave Theory and Techniques, vol. 44 no. 10, Oct. 1996, pp. 1865-1873.
- [12] N. Kuster and Q. Balzano, Energy absorption mechanism by biological bodies in the near field of dipole antennas above 300 MHz, IEEE Transaction on Vehicular Technology, vol. 41, no. 1, Feb. 1992, pp. 17-23.
- [13] G. Hartsgrrove, A. Kraszewski, A. Surowiec, Simulated Biological Materials for Electromagnetic Radiation Absorption Studies, University of Ottawa, Bioelectro magnetics, Canada: 1987, pp. 29-36.
- [14] Q. Balzano, O. Garay, T. Manning Jr., Electromagnetic Energy Exposure of Simulated Users of Portable Cellular Telephones, IEEE Transactions on Vehicular Technology, vol. 44, no.3, Aug. 1995.
- [15] W. Gander, Computer mathematick, Birkhaeuser, Basel, 1992.
- [16] W.H. Press, S.A. Teukolsky, W.T. Vetterling, and B.P. Flannery, Numerical Recepies in C, The Art of Scientific Computing, Second edition, Cambridge University Press, 1992.
- [17] N. Kuster, R. Kastle, T. Schmid, Dosimetric evaluation of mobile communications equipment with known precision, IEEE Transaction on Communications, vol. E80-B, no. 5, May 1997, pp. 645-652.
- [18] CENELEC CLC/SC111B, European Prestandard (prENV 50166-2), Human Exposure to Electromagnetic Fields High-frequency: 10 kHz-300 GHz, Jan. 1995.
- [19] Prof. Dr. Niels Kuster, ETH, EidgenØssische Technische Hoschsschule ZØrich, Dosimetric Evaluation of the Cellular Phone.
- [20] IEC 62209-1, Human exposure to radio frequency fields from hand-held and body-mounted wireless communication devices – Human models, instrumentation and procedures – Part 1:Procedure to determine the specific absorption rate (SAR) for hand-held devices used in close proximity to the ear (frequency range of 300 MHz to 3 GHz), Feb. 2005.

- [21] IEC 62209-2, Human exposure to radio frequency fields from hand-held and body-mounted wireless communication devices – Human models, instrumentation, and procedures – Part 2: Procedure to determine the specific absorption rate (SAR) for wireless communication devices used in close proximity to the human body (frequency range of 30 MHz to 6 GHz) Mar. 2010.
- [22] Industry Canada RSS-102 Radio Frequency Exposure Compliance of Radiocommunication Apparatus (All Frequency Band) Issue 5, March 2015.
- [23] Health Canada Safety Code 6 Limits of Human Exposure to Radio Frequency Electromagnetic Fields in the Frequency Range from 3 kHz – 300 GHz, 2009
- [24] FCC SAR Test procedures for 2G-3G Devices, Mobile Hotspot and UMPC Device KDB 941225 D01.
- [25] SAR Measurement Guidance for IEEE 802.11 transmitters, KDB 248227 D01v02r02
- [26] SAR Evaluation of Handsets with Multiple Transmitters and Antennas KDB 648474 D03, D04.
- [27] SAR Evaluation for Laptop, Notebook, Netbook and Tablet computers KDB 616217 D04.
- [28] SAR Measurement and Reporting Requirements for 100 MHz – 6 GHz, KDB 865664 D01, D02.
- [29] FCC General RF Exposure Guidance and SAR procedures for Dongles, KDB 447498 D01,D02.

## Attachment 1. – SAR Test Plots

Test Laboratory: HCT CO., LTD  
 EUT Type: Mobile Phone  
 Liquid Temperature: 20.5 °C  
 Ambient Temperature: 20.7 °C  
 Test Date: 02/01/2016  
 Plot No.: 1

**DUT: SM-J7108; Type: Bar**

Communication System: GSM 850; Frequency: 836.6 MHz; Duty Cycle: 1:8.3  
 Medium parameters used (interpolated):  $f = 836.6 \text{ MHz}$ ;  $\sigma = 0.901 \text{ mho/m}$ ;  $\epsilon_r = 42.7$ ;  $\rho = 1000 \text{ kg/m}^3$   
 Phantom section: Right Section

DASY4 Configuration:

- Probe: EX3DV4 - SN3863; ConvF(9.46, 9.46, 9.46); Calibrated: 2015-08-27
- Sensor-Surface: 2mm (Mechanical Surface Detection)
- Electronics: DAE4 Sn652; Calibrated: 2016-01-22
- Phantom: SAM Phantom
- Measurement SW: DASY4, V4.7 Build 80
- Postprocessing SW: SEMCAD, V1.8 Build 186

**Right touch 190/Area Scan (71x111x1):** Measurement grid:  $dx=15\text{mm}$ ,  $dy=15\text{mm}$   
 Maximum value of SAR (interpolated) = 0.063 mW/g

**Right touch 190/Zoom Scan (5x5x7)/Cube 0:** Measurement grid:  $dx=8\text{mm}$ ,  $dy=8\text{mm}$ ,  $dz=5\text{mm}$   
 Reference Value = 0.528 V/m; Power Drift = 0.17 dB  
 Peak SAR (extrapolated) = 0.071 W/kg  
**SAR(1 g) = 0.059 mW/g; SAR(10 g) = 0.046 mW/g**  
 Maximum value of SAR (measured) = 0.061 mW/g

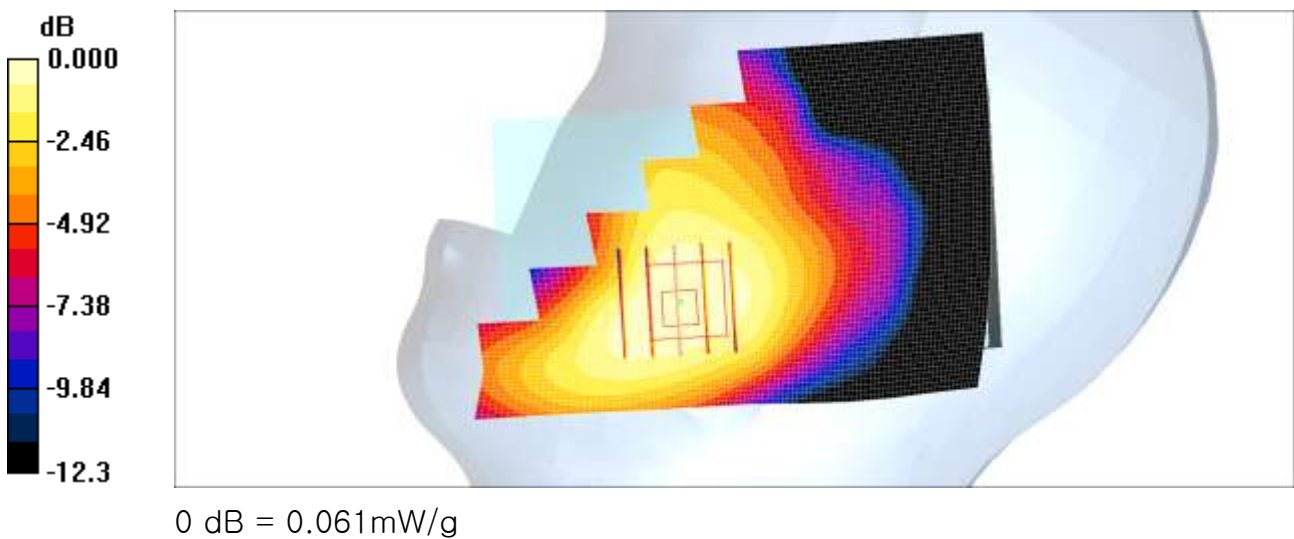

Test Laboratory: HCT CO., LTD  
EUT Type: Mobile Phone  
Liquid Temperature: 22.0 °C  
Ambient Temperature: 22.3 °C  
Test Date: 02/01/2016  
Plot No.: 2

**DUT: SM-J7108; Type: Bar**

Communication System: GSM 1900; Frequency: 1880 MHz; Duty Cycle: 1:8.3  
Medium parameters used:  $f = 1880$  MHz;  $\sigma = 1.39$  mho/m;  $\epsilon_r = 39.4$ ;  $\rho = 1000$  kg/m<sup>3</sup>  
Phantom section: Left Section

DASY4 Configuration:

- Probe: EX3DV4 - SN3967; ConvF(8.11, 8.11, 8.11); Calibrated: 2015-12-16
- Sensor-Surface: 2mm (Mechanical Surface Detection)
- Electronics: DAE4 Sn869; Calibrated: 2015-10-07
- Phantom: SAM Phantom
- Measurement SW: DASY4, V4.7 Build 80
- Postprocessing SW: SEMCAD, V1.8 Build 186

**GSM1900 Head Left touch 661ch/Area Scan (71x121x1):** Measurement grid: dx=15mm, dy=15mm  
Maximum value of SAR (interpolated) = 0.121 mW/g

**GSM1900 Head Left touch 661ch/Zoom Scan (5x5x7)/Cube 0:** Measurement grid: dx=8mm, dy=8mm, dz=5mm

Reference Value = 3.45 V/m; Power Drift = 0.120 dB

Peak SAR (extrapolated) = 0.175 W/kg

**SAR(1 g) = 0.112 mW/g; SAR(10 g) = 0.069 mW/g**

Maximum value of SAR (measured) = 0.119 mW/g

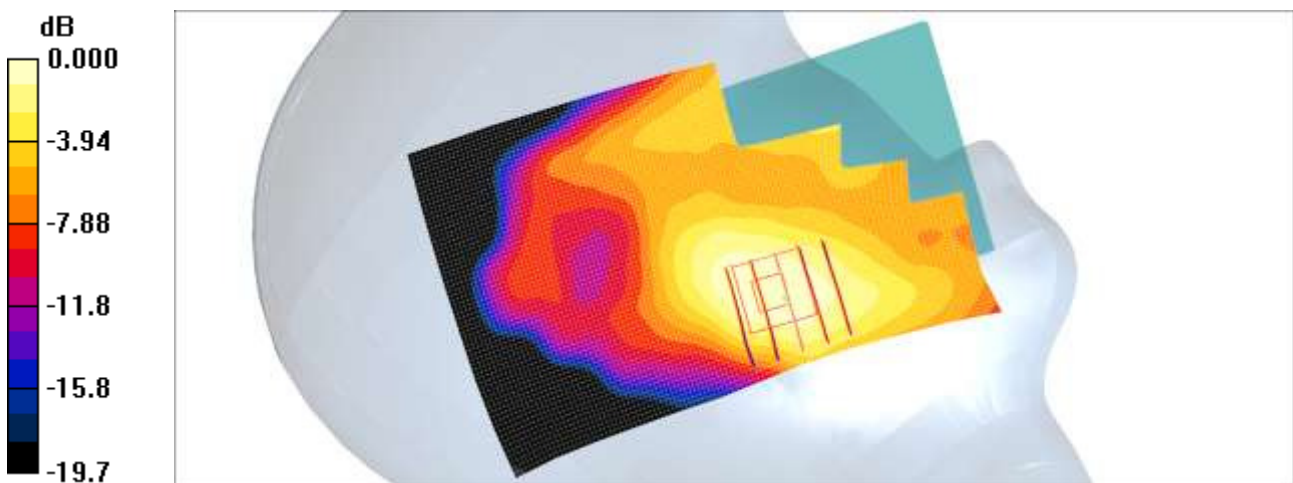

0 dB = 0.119mW/g

Test Laboratory: HCT CO., LTD  
 EUT Type: Mobile Phone  
 Liquid Temperature: 20.5 °C  
 Ambient Temperature: 20.7 °C  
 Test Date: 02/01/2016  
 Plot No.: 3

**DUT: SM-J7108; Type: Bar**

Communication System: WCDMA850; Frequency: 836.6 MHz; Duty Cycle: 1:1  
 Medium parameters used (interpolated):  $f = 836.6 \text{ MHz}$ ;  $\sigma = 0.901 \text{ mho/m}$ ;  $\epsilon_r = 42.7$ ;  $\rho = 1000 \text{ kg/m}^3$   
 Phantom section: Left Section

DASY4 Configuration:

- Probe: EX3DV4 - SN3863; ConvF(9.46, 9.46, 9.46); Calibrated: 2015-08-27
- Sensor-Surface: 2mm (Mechanical Surface Detection)
- Electronics: DAE4 Sn652; Calibrated: 2016-01-22
- Phantom: SAM
- Measurement SW: DASY4, V4.7 Build 80
- Postprocessing SW: SEMCAD, V1.8 Build 186

**WCDMA 850 Left touch 4183/Area Scan (71x111x1):** Measurement grid:  $dx=15\text{mm}$ ,  $dy=15\text{mm}$   
 Maximum value of SAR (interpolated) = 0.092 mW/g

**WCDMA 850 Left touch 4183/Zoom Scan (5x5x7)/Cube 0:** Measurement grid:  $dx=8\text{mm}$ ,  $dy=8\text{mm}$ ,  $dz=5\text{mm}$   
 Reference Value = 4.41 V/m; Power Drift = -0.140 dB  
 Peak SAR (extrapolated) = 0.150 W/kg  
**SAR(1 g) = 0.083 mW/g; SAR(10 g) = 0.046 mW/g**  
 Maximum value of SAR (measured) = 0.090 mW/g

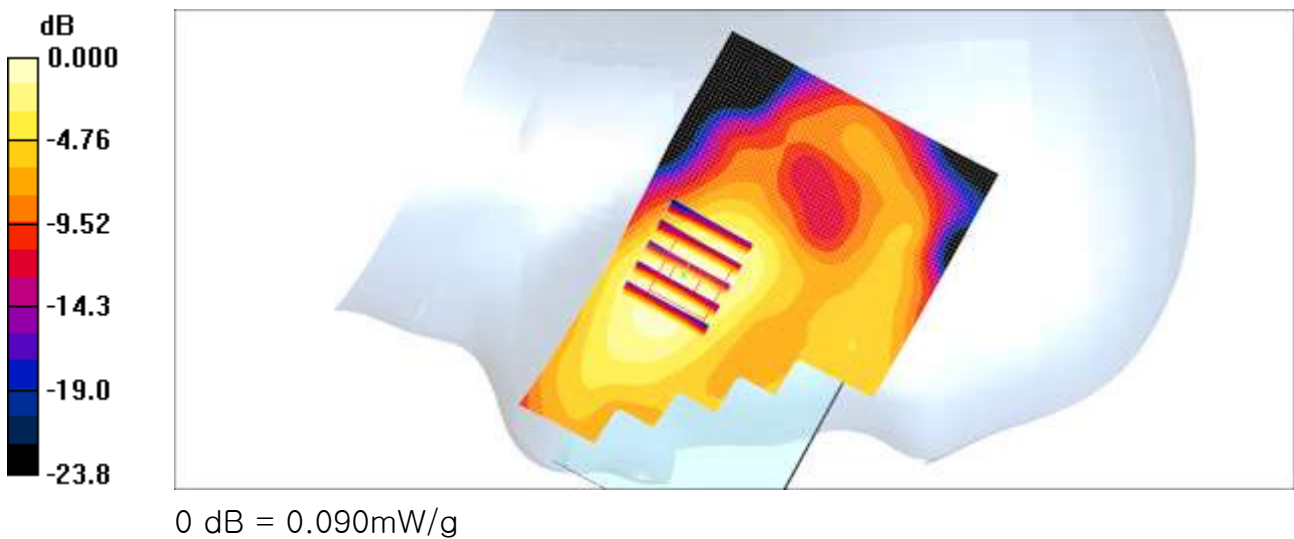

Test Laboratory: HCT CO., LTD  
 EUT Type: Mobile Phone  
 Liquid Temperature: 22.0 °C  
 Ambient Temperature: 22.3 °C  
 Test Date: 02/01/2016  
 Plot No.: 4

**DUT: SM-J7108; Type: Bar**

Communication System: WCDMA1900; Frequency: 1880 MHz; Duty Cycle: 1:1  
 Medium parameters used:  $f = 1880 \text{ MHz}$ ;  $\sigma = 1.39 \text{ mho/m}$ ;  $\epsilon_r = 39.4$ ;  $\rho = 1000 \text{ kg/m}^3$   
 Phantom section: Left Section

DASY4 Configuration:

- Probe: EX3DV4 - SN3967; ConvF(8.11, 8.11, 8.11); Calibrated: 2015-12-16
- Sensor-Surface: 2mm (Mechanical Surface Detection)
- Electronics: DAE4 Sn869; Calibrated: 2015-10-07
- Phantom: SAM Phantom
- Measurement SW: DASY4, V4.7 Build 80
- Postprocessing SW: SEMCAD, V1.8 Build 186

**WCDMA1900 Head Left touch 9400ch/Area Scan (71x121x1):** Measurement grid: dx=15mm, dy=15mm  
 Maximum value of SAR (interpolated) = 0.179 mW/g

**WCDMA1900 Head Left touch 9400ch/Zoom Scan (5x5x7)/Cube 0:** Measurement grid: dx=8mm, dy=8mm, dz=5mm

Reference Value = 5.12 V/m; Power Drift = -0.180 dB

Peak SAR (extrapolated) = 0.252 W/kg

**SAR(1 g) = 0.166 mW/g; SAR(10 g) = 0.104 mW/g**

Maximum value of SAR (measured) = 0.180 mW/g

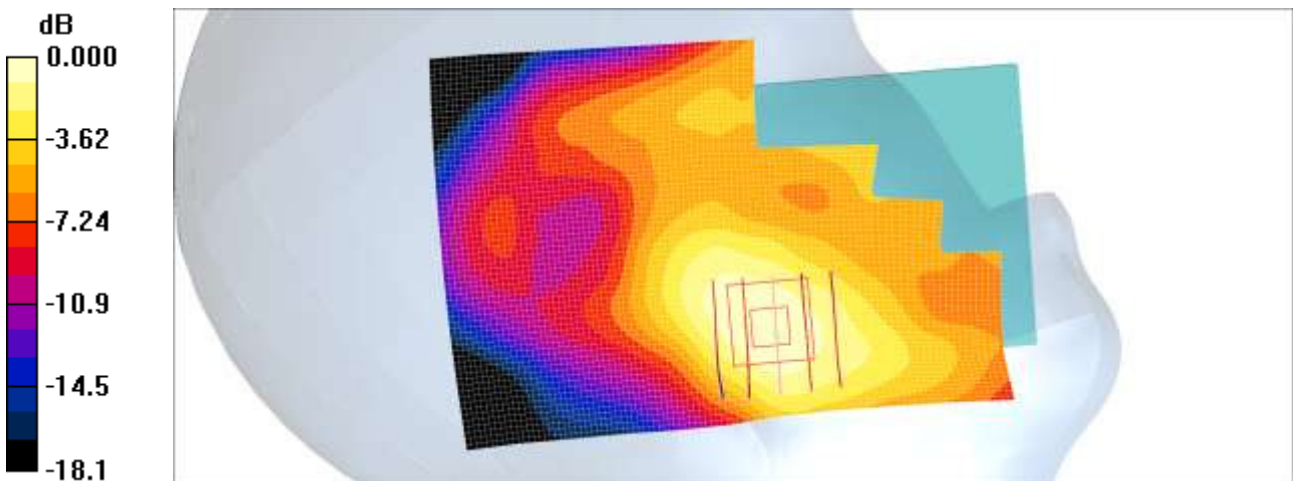

0 dB = 0.180mW/g

Test Laboratory: HCT CO., LTD  
 EUT Type: Mobile Phone  
 Liquid Temperature: 21.5 °C  
 Ambient Temperature: 21.8 °C  
 Test Date: 02/02/2016  
 Plot No.: 5

**DUT: SM-J7108; Type: Bar**

Communication System: LTE Band 41; Frequency: 2565 MHz; Duty Cycle: 1:1.58  
 Medium parameters used (interpolated):  $f = 2565 \text{ MHz}$ ;  $\sigma = 1.95 \text{ mho/m}$ ;  $\epsilon_r = 37.8$ ;  $\rho = 1000 \text{ kg/m}^3$   
 Phantom section: Right Section

DASY4 Configuration:

- Probe: EX3DV4 - SN3967; ConvF(7.17, 7.17, 7.17); Calibrated: 2015-12-16
- Sensor-Surface: 2mm (Mechanical Surface Detection)
- Electronics: DAE4 Sn869; Calibrated: 2015-10-07
- Phantom: SAM Phantom
- Measurement SW: DASY4, V4.7 Build 80
- Postprocessing SW: SEMCAD, V1.8 Build 186

**LTE band 41 Right touch QPSK 20MHz 1RB 0offset 40340/Area Scan (91x151x1):** Measurement grid:  $dx=12\text{mm}$ ,  $dy=12\text{mm}$   
 Maximum value of SAR (interpolated) = 0.110 mW/g

**LTE band 41 Right touch QPSK 20MHz 1RB 0offset 40340/Zoom Scan (7x7x7)/Cube 0:** Measurement grid:  $dx=5\text{mm}$ ,  $dy=5\text{mm}$ ,  $dz=5\text{mm}$   
 Reference Value = 2.31 V/m; Power Drift = 0.100 dB  
 Peak SAR (extrapolated) = 0.119 W/kg  
**SAR(1 g) = 0.065 mW/g; SAR(10 g) = 0.035 mW/g**  
 Maximum value of SAR (measured) = 0.090 mW/g

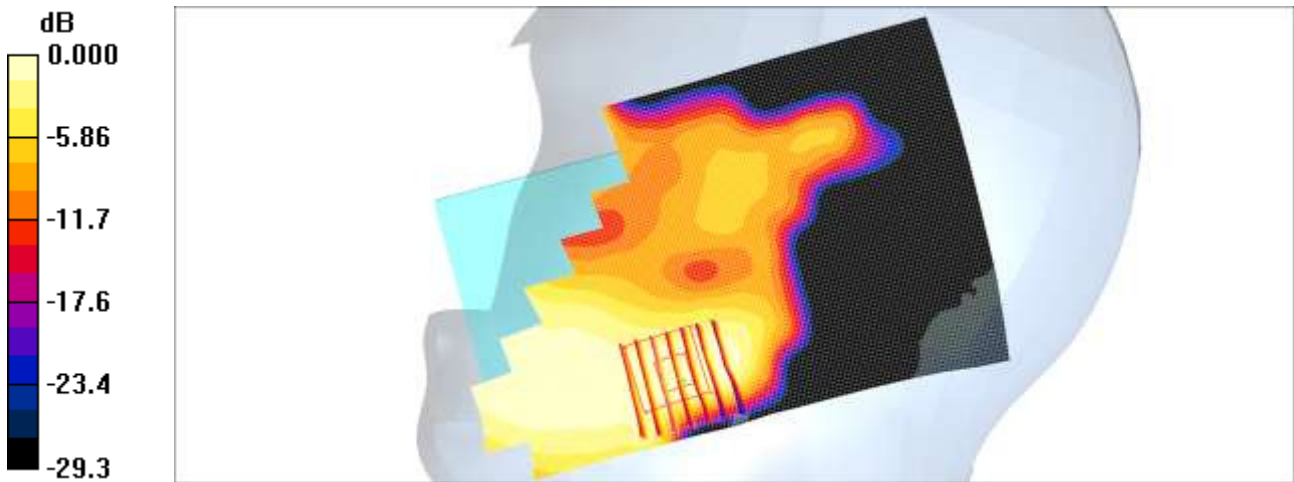

0 dB = 0.090mW/g

Test Laboratory: HCT CO., LTD  
EUT Type: Mobile Phone  
Liquid Temperature: 21.2 °C  
Ambient Temperature: 21.7 °C  
Test Date: 02/04/2016  
Plot No.: 6

**DUT: SM-J7108; Type: Bar**

Communication System: 2450MHz FCC; Frequency: 2437 MHz; Duty Cycle: 1:1  
Medium parameters used (interpolated):  $f = 2437$  MHz;  $\sigma = 1.82$  mho/m;  $\epsilon_r = 38.3$ ;  $\rho = 1000$  kg/m<sup>3</sup>  
Phantom section: Left Section

DASY4 Configuration:

- Probe: EX3DV4 - SN3967; ConvF(7.42, 7.42, 7.42); Calibrated: 2015-12-16
- Sensor-Surface: 2mm (Mechanical Surface Detection)
- Electronics: DAE4 Sn869; Calibrated: 2015-10-07
- Phantom: SAM Phantom
- Measurement SW: DASY4, V4.7 Build 80
- Postprocessing SW: SEMCAD, V1.8 Build 186

**802.11b Left touch 1Mbps 6ch/Area Scan (91x151x1):** Measurement grid: dx=12mm, dy=12mm  
Maximum value of SAR (interpolated) = 1.06 mW/g

**802.11b Left touch 1Mbps 6ch/Zoom Scan (7x7x7)/Cube 0:** Measurement grid: dx=5mm, dy=5mm, dz=5mm

Reference Value = 9.78 V/m; Power Drift = -0.18 dB

Peak SAR (extrapolated) = 1.61 W/kg

**SAR(1 g) = 0.664 mW/g; SAR(10 g) = 0.303 mW/g**

Maximum value of SAR (measured) = 1.11 mW/g

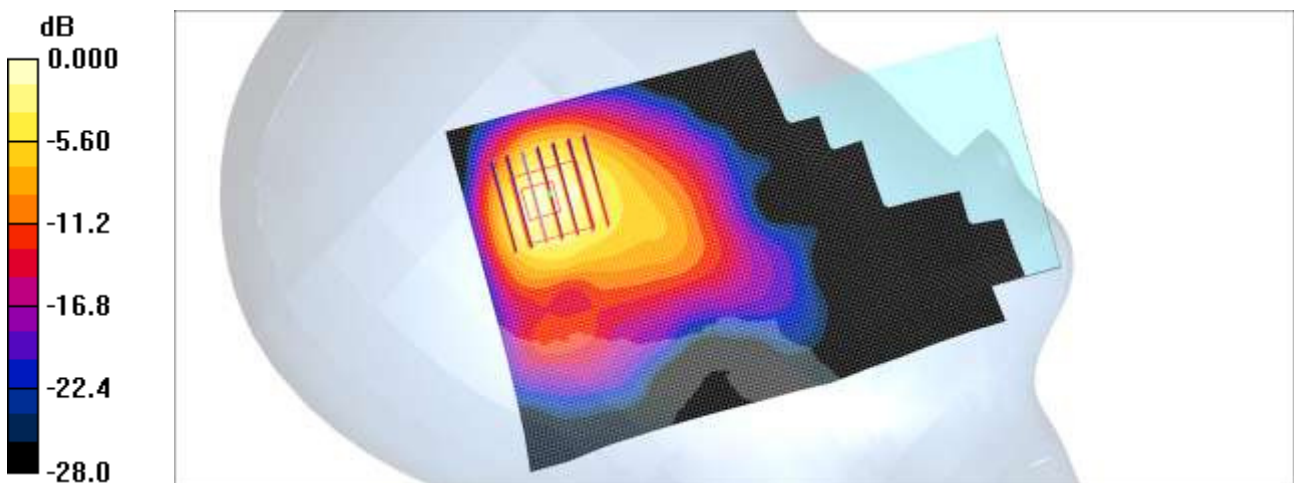

0 dB = 1.11mW/g

Test Laboratory: HCT CO., LTD  
EUT Type: Mobile Phone  
Liquid Temperature: 20.7 °C  
Ambient Temperature: 20.9 °C  
Test Date: 02/02/2016  
Plot No.: 7

**DUT: SM-J7108; Type: Bar**

Communication System: GSM 850; Frequency: 836.6 MHz; Duty Cycle: 1:8.3  
Medium parameters used (interpolated):  $f = 836.6$  MHz;  $\sigma = 0.987$  mho/m;  $\epsilon_r = 54.4$ ;  $\rho = 1000$  kg/m<sup>3</sup>  
Phantom section: Center Section

DASY4 Configuration:

- Probe: EX3DV4 - SN3863; ConvF(9.4, 9.4, 9.4); Calibrated: 2015-08-27
- Sensor-Surface: 2mm (Mechanical Surface Detection)
- Electronics: DAE4 Sn652; Calibrated: 2016-01-22
- Phantom: Triple Flat Phantom
- Measurement SW: DASY4, V4.7 Build 80
- Postprocessing SW: SEMCAD, V1.8 Build 186

**GSM850 Body Front 190ch/Area Scan (71x111x1):** Measurement grid: dx=15mm, dy=15mm  
Maximum value of SAR (interpolated) = 0.161 mW/g

**GSM850 Body Front 190ch/Zoom Scan (5x5x7)/Cube 0:** Measurement grid: dx=8mm, dy=8mm, dz=5mm  
Reference Value = 8.09 V/m; Power Drift = 0.001 dB  
Peak SAR (extrapolated) = 0.202 W/kg  
**SAR(1 g) = 0.152 mW/g; SAR(10 g) = 0.108 mW/g**  
Maximum value of SAR (measured) = 0.162 mW/g

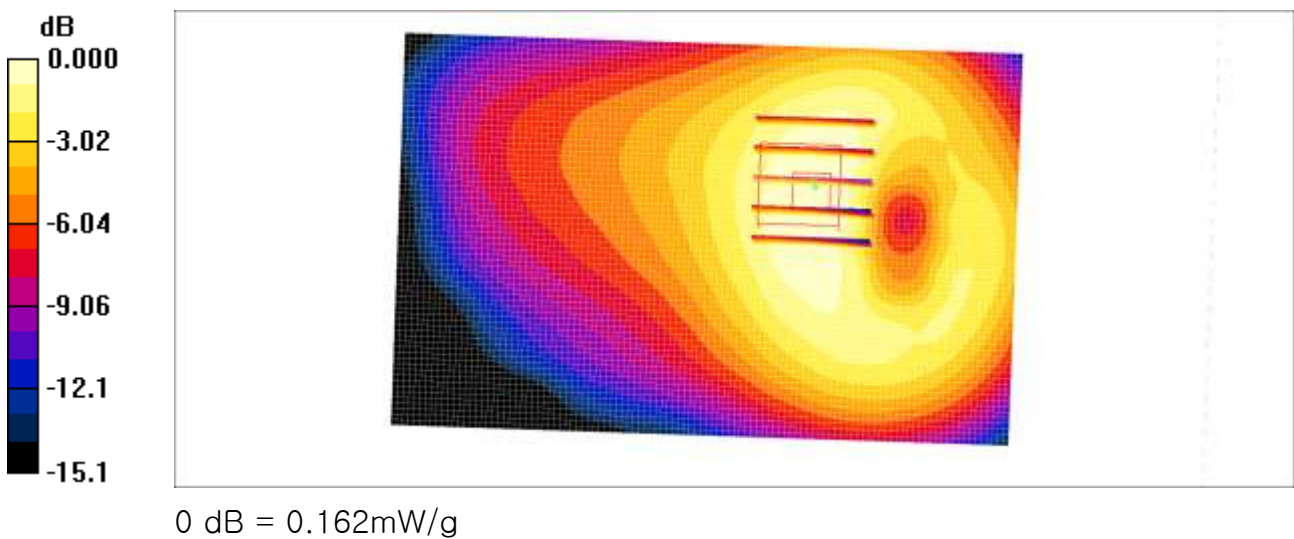

Test Laboratory: HCT CO., LTD  
EUT Type: Mobile Phone  
Liquid Temperature: 21.0 °C  
Ambient Temperature: 21.2 °C  
Test Date: 02/03/2016  
Plot No.: 8

**DUT: SM-J7108; Type: Bar**

Communication System: GSM 1900; Frequency: 1880 MHz; Duty Cycle: 1:8.3  
Medium parameters used:  $f = 1880$  MHz;  $\sigma = 1.52$  mho/m;  $\epsilon_r = 55$ ;  $\rho = 1000$  kg/m<sup>3</sup>  
Phantom section: Center Section

DASY4 Configuration:

- Probe: EX3DV4 - SN3863; ConvF(7.48, 7.48, 7.48); Calibrated: 2015-08-27
- Sensor-Surface: 2mm (Mechanical Surface Detection)
- Electronics: DAE4 Sn652; Calibrated: 2016-01-22
- Phantom: Triple Flat Phantom
- Measurement SW: DASY4, V4.7 Build 80
- Postprocessing SW: SEMCAD, V1.8 Build 186

**GSM1900 Body Front 661ch/Area Scan (71x111x1):** Measurement grid: dx=15mm, dy=15mm  
Maximum value of SAR (interpolated) = 0.212 mW/g

**GSM1900 Body Front 661ch/Zoom Scan (5x5x7)/Cube 0:** Measurement grid: dx=8mm, dy=8mm, dz=5mm  
Reference Value = 7.12 V/m; Power Drift = -0.041 dB  
Peak SAR (extrapolated) = 0.308 W/kg  
**SAR(1 g) = 0.199 mW/g; SAR(10 g) = 0.123 mW/g**  
Maximum value of SAR (measured) = 0.213 mW/g

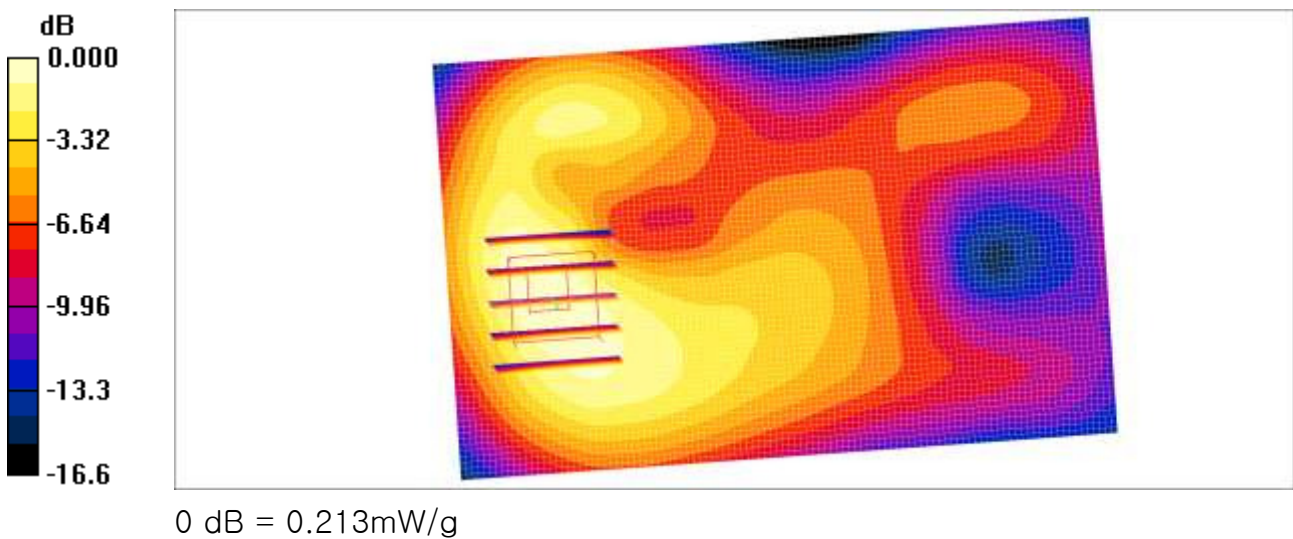

Test Laboratory: HCT CO., LTD  
EUT Type: Mobile Phone  
Liquid Temperature: 20.7 °C  
Ambient Temperature: 20.9 °C  
Test Date: 02/02/2016  
Plot No.: 9

**DUT: SM-J7108; Type: Bar**

Communication System: WCDMA850; Frequency: 836.6 MHz; Duty Cycle: 1:1  
Medium parameters used (interpolated):  $f = 836.6$  MHz;  $\sigma = 0.987$  mho/m;  $\epsilon_r = 54.4$ ;  $\rho = 1000$  kg/m<sup>3</sup>  
Phantom section: Center Section

DASY4 Configuration:

- Probe: EX3DV4 - SN3863; ConvF(9.4, 9.4, 9.4); Calibrated: 2015-08-27
- Sensor-Surface: 2mm (Mechanical Surface Detection)
- Electronics: DAE4 Sn652; Calibrated: 2016-01-22
- Phantom: Triple Flat Phantom
- Measurement SW: DASY4, V4.7 Build 80
- Postprocessing SW: SEMCAD, V1.8 Build 186

**WCDMA850 Body Front 4183/Area Scan (71x111x1):** Measurement grid: dx=15mm, dy=15mm  
Maximum value of SAR (interpolated) = 0.204 mW/g

**WCDMA850 Body Front 4183/Zoom Scan (5x5x7)/Cube 0:** Measurement grid: dx=8mm, dy=8mm, dz=5mm

Reference Value = 8.32 V/m; Power Drift = -0.045 dB

Peak SAR (extrapolated) = 0.355 W/kg

**SAR(1 g) = 0.189 mW/g; SAR(10 g) = 0.104 mW/g**

Maximum value of SAR (measured) = 0.204 mW/g

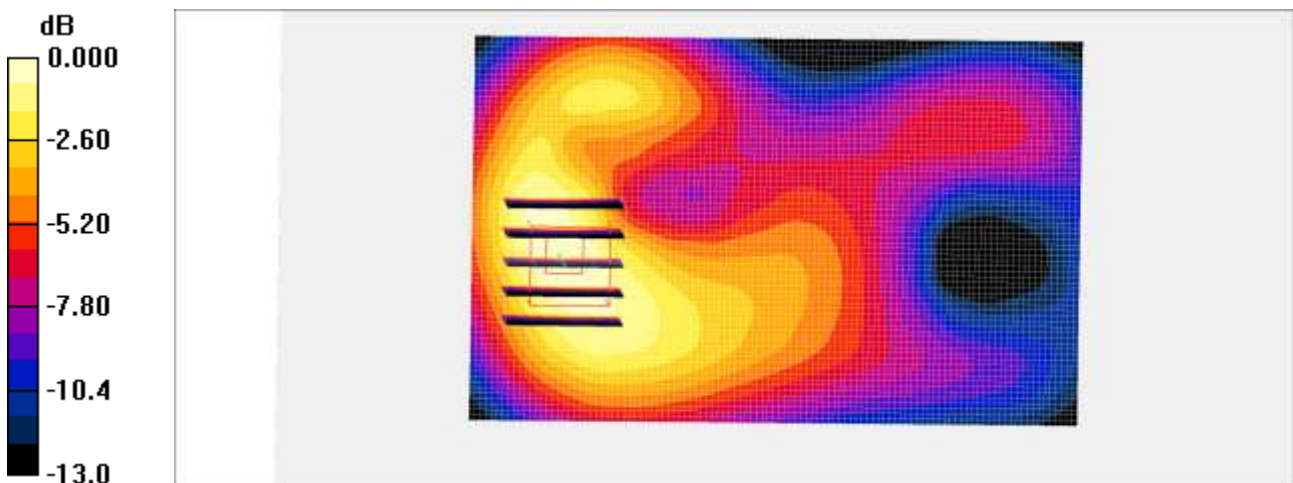

0 dB = 0.204mW/g

Test Laboratory: HCT CO., LTD  
 EUT Type: Mobile Phone  
 Liquid Temperature: 21.0 °C  
 Ambient Temperature: 21.2 °C  
 Test Date: 02/03/2016  
 Plot No.: 10

**DUT: SM-J7108; Type: Bar**

Communication System: WCDMA1900; Frequency: 1880 MHz; Duty Cycle: 1:1  
 Medium parameters used:  $f = 1880 \text{ MHz}$ ;  $\sigma = 1.53 \text{ mho/m}$ ;  $\epsilon_r = 55$ ;  $\rho = 1000 \text{ kg/m}^3$   
 Phantom section: Center Section

DASY4 Configuration:

- Probe: EX3DV4 - SN3863; ConvF(7.48, 7.48, 7.48); Calibrated: 2015-08-27
- Sensor-Surface: 2mm (Mechanical Surface Detection)
- Electronics: DAE4 Sn652; Calibrated: 2016-01-22
- Phantom: Triple Flat Phantom
- Measurement SW: DASY4, V4.7 Build 80
- Postprocessing SW: SEMCAD, V1.8 Build 186

**WCDMA1900 Body Front 15mm 9400ch/Area Scan (71x111x1):** Measurement grid: dx=15mm, dy=15mm  
 Maximum value of SAR (interpolated) = 0.381 mW/g

**WCDMA1900 Body Front 15mm 9400ch/Zoom Scan (5x5x7)/Cube 0:** Measurement grid: dx=8mm, dy=8mm, dz=5mm

Reference Value = 9.11 V/m; Power Drift = -0.046 dB

Peak SAR (extrapolated) = 0.538 W/kg

**SAR(1 g) = 0.348 mW/g; SAR(10 g) = 0.218 mW/g**

Maximum value of SAR (measured) = 0.376 mW/g

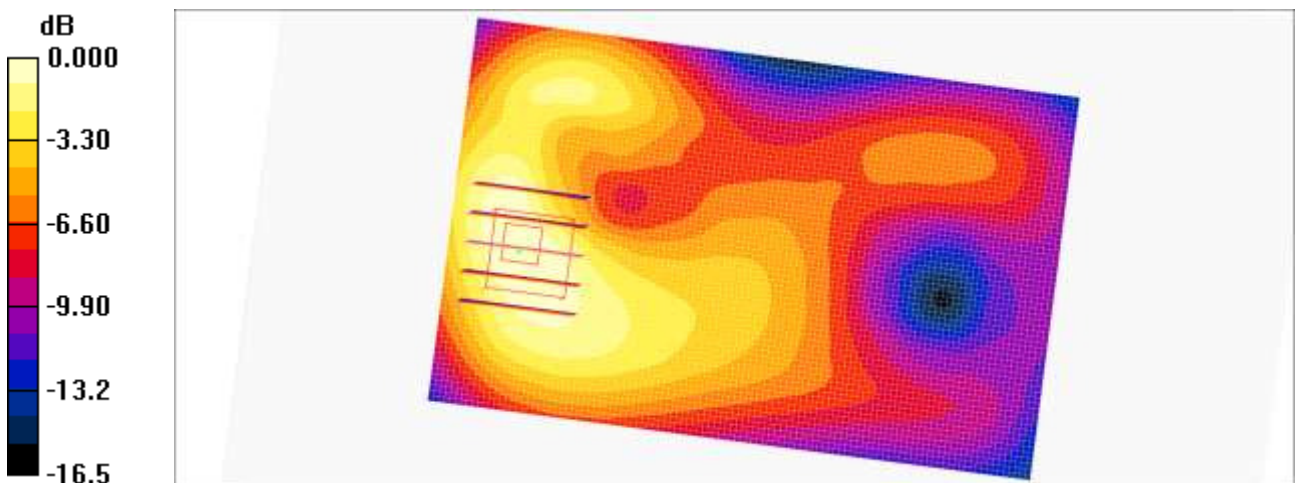

0 dB = 0.376mW/g

Test Laboratory: HCT CO., LTD  
 EUT Type: Mobile Phone  
 Liquid Temperature: 21.6 °C  
 Ambient Temperature: 22.0 °C  
 Test Date: 02/03/2016  
 Plot No.: 11

**DUT: SM-J7108; Type: Bar**

Communication System: LTE 41; Frequency: 2565 MHz; Duty Cycle: 1:1.58  
 Medium parameters used (interpolated):  $f = 2565$  MHz;  $\sigma = 2.05$  mho/m;  $\epsilon_r = 51.3$ ;  $\rho = 1000$  kg/m<sup>3</sup>  
 Phantom section: Center Section

DASY4 Configuration:

- Probe: EX3DV4 - SN3967; ConvF(7.19, 7.19, 7.19); Calibrated: 2015-12-16
- Sensor-Surface: 2mm (Mechanical Surface Detection)
- Electronics: DAE4 Sn869; Calibrated: 2015-10-07
- Phantom: Triple Flat Phantom
- Measurement SW: DASY4, V4.7 Build 80
- Postprocessing SW: SEMCAD, V1.8 Build 186

**LTE band 41 Body front QPSK 20MHz 1RB 0offset 40340/Area Scan (91x151x1):** Measurement grid:  
 $dx=12$ mm,  $dy=12$ mm  
 Maximum value of SAR (interpolated) = 0.524 mW/g

**LTE band 41 Body front QPSK 20MHz 1RB 0offset 40340/Zoom Scan (7x7x7)/Cube 0:** Measurement grid:  
 $dx=5$ mm,  $dy=5$ mm,  $dz=5$ mm  
 Reference Value = 1.06 V/m; Power Drift = 0.150 dB  
 Peak SAR (extrapolated) = 0.710 W/kg  
**SAR(1 g) = 0.353 mW/g; SAR(10 g) = 0.179 mW/g**  
 Maximum value of SAR (measured) = 0.521 mW/g

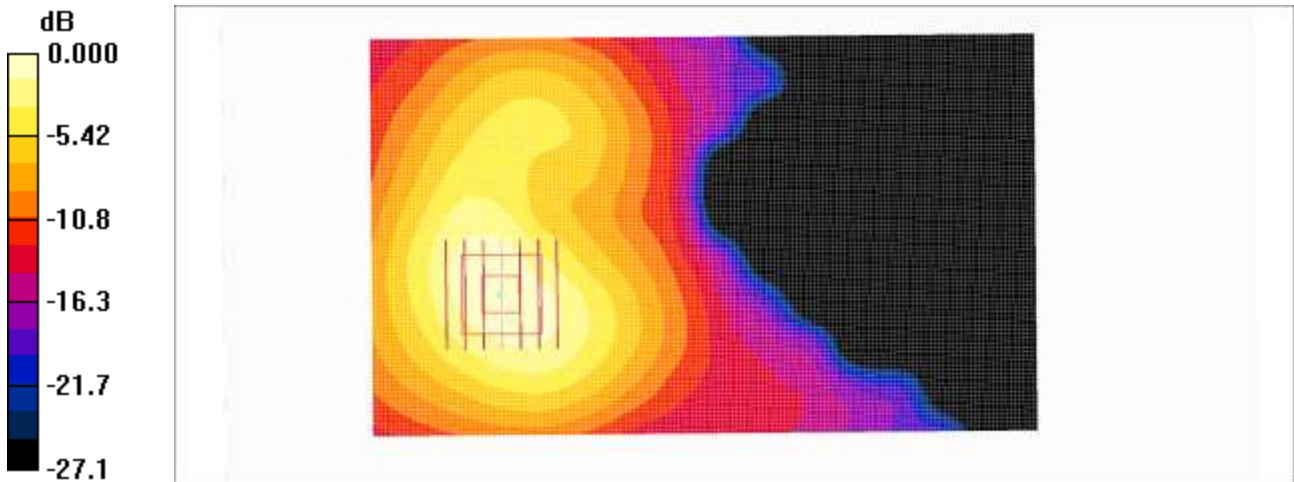

0 dB = 0.521mW/g

Test Laboratory: HCT CO., LTD  
 EUT Type: Mobile Phone  
 Liquid Temperature: 21.2 °C  
 Ambient Temperature: 21.7 °C  
 Test Date: 02/04/2016  
 Plot No.: 12

**DUT: SM-J7108; Type: Bar**

Communication System: 2450MHz FCC; Frequency: 2437 MHz;Duty Cycle: 1:1  
 Medium parameters used (interpolated):  $f = 2437$  MHz;  $\sigma = 1.9$  mho/m;  $\epsilon_r = 51.6$ ;  $\rho = 1000$  kg/m<sup>3</sup>  
 Phantom section: Center Section

DASY4 Configuration:

- Probe: EX3DV4 - SN3967; ConvF(7.31, 7.31, 7.31); Calibrated: 2015-12-16
- Sensor-Surface: 2mm (Mechanical Surface Detection)
- Electronics: DAE4 Sn869; Calibrated: 2015-10-07
- Phantom: Triple Flat Phantom
- Measurement SW: DASY4, V4.7 Build 80
- Postprocessing SW: SEMCAD, V1.8 Build 186

**802.11b Body Front 1Mbps 6ch/Area Scan (91x151x1):** Measurement grid: dx=12mm, dy=12mm  
 Maximum value of SAR (interpolated) = 0.068 mW/g

**802.11b Body Front 1Mbps 6ch/Zoom Scan (7x7x7)/Cube 0:** Measurement grid: dx=5mm, dy=5mm, dz=5mm

Reference Value = 2.82 V/m; Power Drift = 0.124 dB

Peak SAR (extrapolated) = 0.097 W/kg

**SAR(1 g) = 0.046 mW/g; SAR(10 g) = 0.023 mW/g**

Maximum value of SAR (measured) = 0.069 mW/g

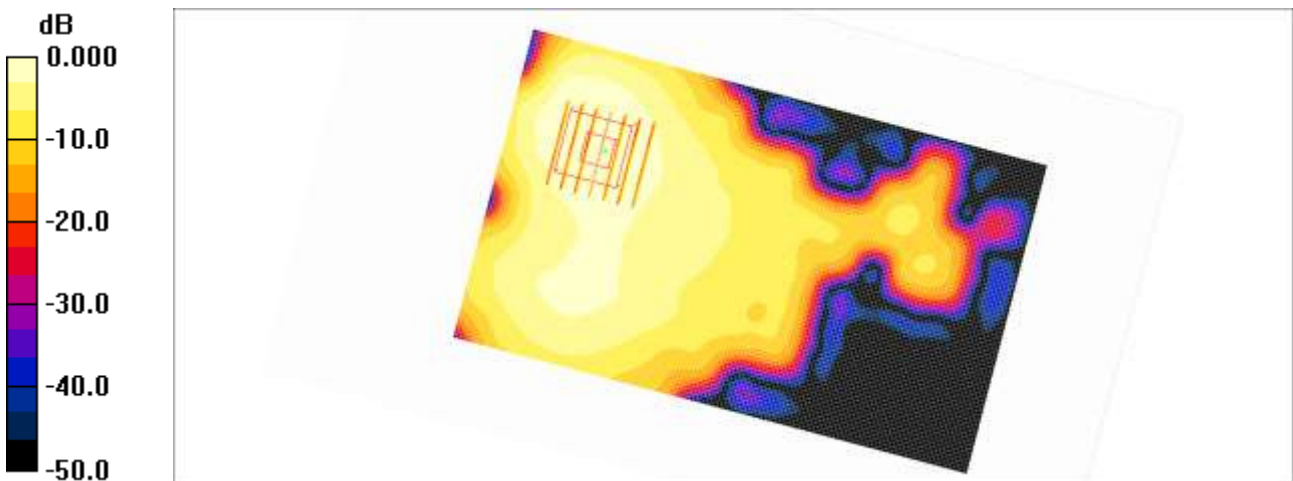

0 dB = 0.069mW/g

Test Laboratory: HCT CO., LTD  
 EUT Type: Mobile Phone  
 Liquid Temperature: 20.7 °C  
 Ambient Temperature: 20.9 °C  
 Test Date: 02/02/2016  
 Plot No.: 13

**DUT: SM-J7108; Type: Bar**

Communication System: GSM 850; Frequency: 836.6 MHz; Duty Cycle: 1:4.15  
 Medium parameters used (interpolated):  $f = 836.6 \text{ MHz}$ ;  $\sigma = 0.987 \text{ mho/m}$ ;  $\epsilon_r = 54.4$ ;  $\rho = 1000 \text{ kg/m}^3$   
 Phantom section: Center Section

DASY4 Configuration:

- Probe: EX3DV4 - SN3863; ConvF(9.4, 9.4, 9.4); Calibrated: 2015-08-27
- Sensor-Surface: 2mm (Mechanical Surface Detection)
- Electronics: DAE4 Sn652; Calibrated: 2016-01-22
- Phantom: Triple Flat Phantom
- Measurement SW: DASY4, V4.7 Build 80
- Postprocessing SW: SEMCAD, V1.8 Build 186

**GSM850 Body Bottom 2Tx 190ch/Area Scan (71x61x1):** Measurement grid:  $dx=15\text{mm}$ ,  $dy=15\text{mm}$   
 Maximum value of SAR (interpolated) = 0.215 mW/g

**GSM850 Body Bottom 2Tx 190ch/Zoom Scan (5x5x7)/Cube 0:** Measurement grid:  $dx=8\text{mm}$ ,  $dy=8\text{mm}$ ,  $dz=5\text{mm}$

Reference Value = 14.2 V/m; Power Drift = 0.022 dB

Peak SAR (extrapolated) = 0.282 W/kg

**SAR(1 g) = 0.192 mW/g; SAR(10 g) = 0.117 mW/g**

Maximum value of SAR (measured) = 0.212 mW/g

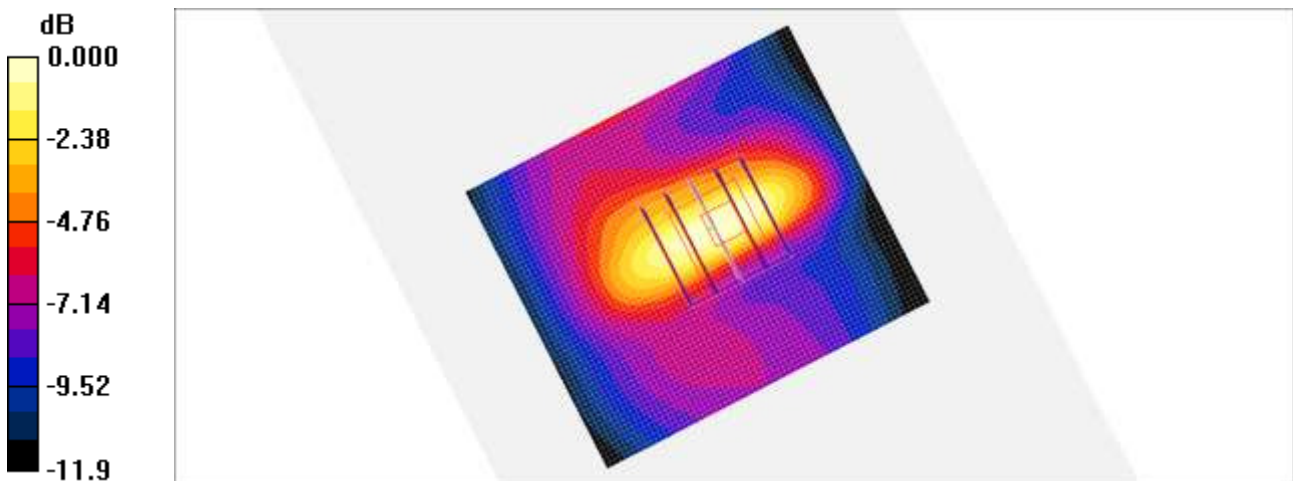

0 dB = 0.212mW/g

Test Laboratory: HCT CO., LTD  
 EUT Type: Mobile Phone  
 Liquid Temperature: 21.0 °C  
 Ambient Temperature: 21.2 °C  
 Test Date: 02/03/2016  
 Plot No.: 14

**DUT: SM-J7108; Type: Bar**

Communication System: GSM 1900; Frequency: 1850.2 MHz; Duty Cycle: 1:4.15  
 Medium parameters used (interpolated):  $f = 1850.2$  MHz;  $\sigma = 1.49$  mho/m;  $\epsilon_r = 55.1$ ;  $\rho = 1000$  kg/m<sup>3</sup>  
 Phantom section: Center Section

DASY4 Configuration:

- Probe: EX3DV4 - SN3863; ConvF(7.48, 7.48, 7.48); Calibrated: 2015-08-27
- Sensor-Surface: 2mm (Mechanical Surface Detection)
- Electronics: DAE4 Sn652; Calibrated: 2016-01-22
- Phantom: Triple Flat Phantom
- Measurement SW: DASY4, V4.7 Build 80
- Postprocessing SW: SEMCAD, V1.8 Build 186

**GSM1900 Body Bottom 2Tx 512ch/Area Scan (71x61x1):** Measurement grid: dx=15mm, dy=15mm  
 Maximum value of SAR (interpolated) = 0.702 mW/g

**GSM1900 Body Bottom 2Tx 512ch/Zoom Scan (5x5x7)/Cube 0:** Measurement grid: dx=8mm, dy=8mm, dz=5mm

Reference Value = 21.0 V/m; Power Drift = -0.049 dB

Peak SAR (extrapolated) = 1.01 W/kg

**SAR(1 g) = 0.610 mW/g; SAR(10 g) = 0.346 mW/g**

Maximum value of SAR (measured) = 0.679 mW/g

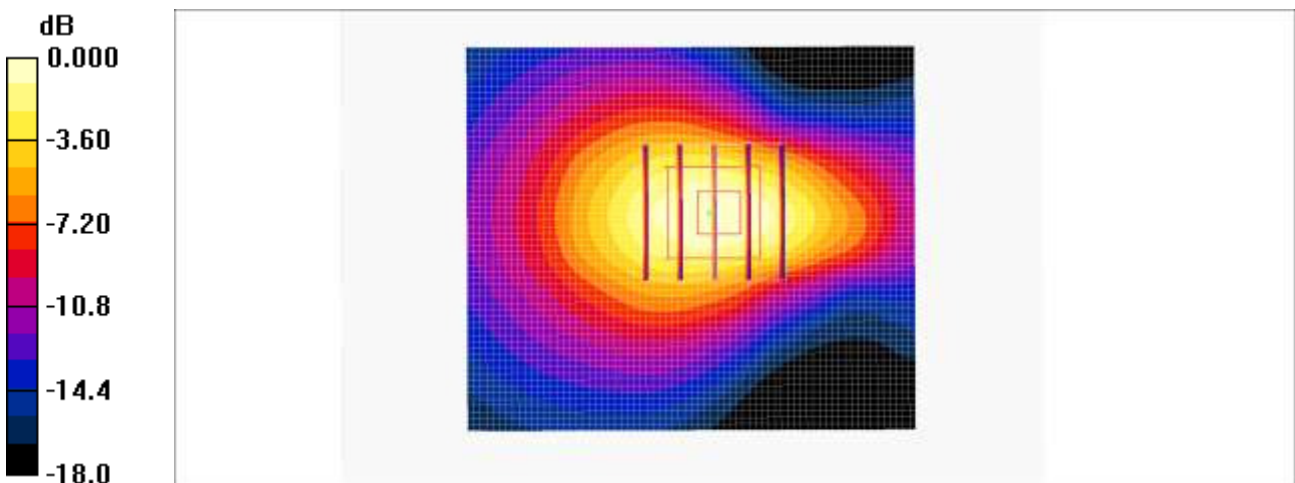

0 dB = 0.679mW/g

Test Laboratory: HCT CO., LTD  
EUT Type: Mobile Phone  
Liquid Temperature: 20.7 °C  
Ambient Temperature: 20.9 °C  
Test Date: 02/02/2016  
Plot No.: 15

**DUT: SM-J7108; Type: Bar**

Communication System: WCDMA850; Frequency: 836.6 MHz; Duty Cycle: 1:1  
Medium parameters used (interpolated):  $f = 836.6$  MHz;  $\sigma = 0.987$  mho/m;  $\epsilon_r = 54.4$ ;  $\rho = 1000$  kg/m<sup>3</sup>  
Phantom section: Center Section

DASY4 Configuration:

- Probe: EX3DV4 - SN3863; ConvF(9.4, 9.4, 9.4); Calibrated: 2015-08-27
- Sensor-Surface: 2mm (Mechanical Surface Detection)
- Electronics: DAE4 Sn652; Calibrated: 2016-01-22
- Phantom: Triple Flat Phantom
- Measurement SW: DASY4, V4.7 Build 80
- Postprocessing SW: SEMCAD, V1.8 Build 186

**WCDMA850 Body Bottom 4183/Area Scan (71x61x1):** Measurement grid: dx=15mm, dy=15mm  
Maximum value of SAR (interpolated) = 0.642 mW/g

**WCDMA850 Body Bottom 4183/Zoom Scan (5x5x7)/Cube 0:** Measurement grid: dx=8mm, dy=8mm, dz=5mm

Reference Value = 24.8 V/m; Power Drift = -0.006 dB

Peak SAR (extrapolated) = 1.16 W/kg

**SAR(1 g) = 0.559 mW/g; SAR(10 g) = 0.274 mW/g**

Maximum value of SAR (measured) = 0.616 mW/g

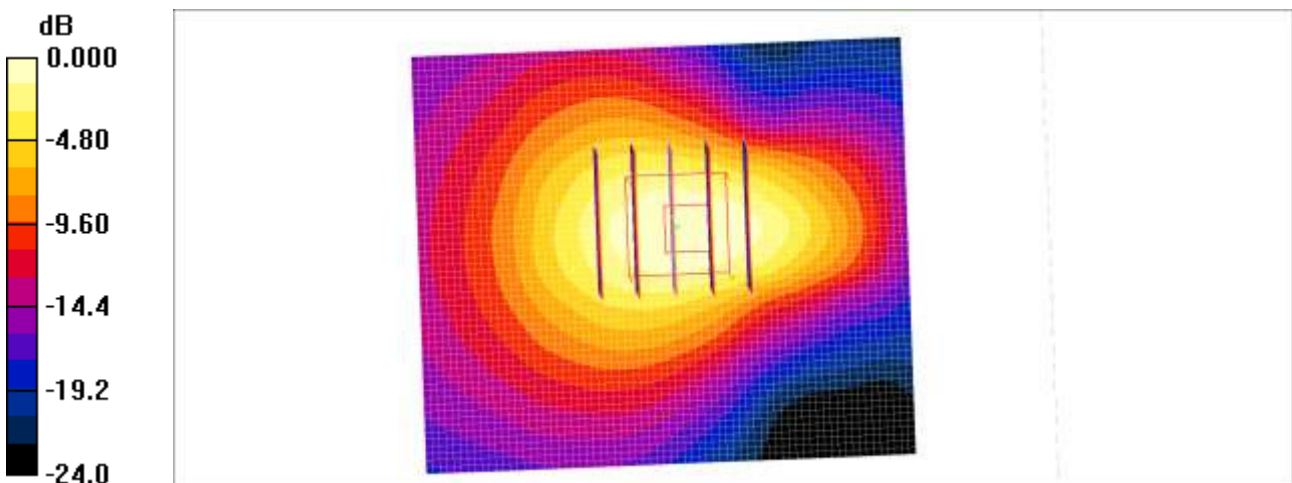

0 dB = 0.616mW/g

Test Laboratory: HCT CO., LTD  
 EUT Type: Mobile Phone  
 Liquid Temperature: 21.0 °C  
 Ambient Temperature: 21.2 °C  
 Test Date: 02/03/2016  
 Plot No.: 16

**DUT: SM-J7108; Type: Bar**

Communication System: WCDMA1900; Frequency: 1880 MHz; Duty Cycle: 1:1  
 Medium parameters used:  $f = 1880 \text{ MHz}$ ;  $\sigma = 1.53 \text{ mho/m}$ ;  $\epsilon_r = 55$ ;  $\rho = 1000 \text{ kg/m}^3$   
 Phantom section: Center Section

DASY4 Configuration:

- Probe: EX3DV4 - SN3863; ConvF(7.48, 7.48, 7.48); Calibrated: 2015-08-27
- Sensor-Surface: 2mm (Mechanical Surface Detection)
- Electronics: DAE4 Sn652; Calibrated: 2016-01-22
- Phantom: Triple Flat Phantom
- Measurement SW: DASY4, V4.7 Build 80
- Postprocessing SW: SEMCAD, V1.8 Build 186

**WCDMA1900 Body Bottom 9400ch/Area Scan (71x61x1):** Measurement grid: dx=15mm, dy=15mm  
 Maximum value of SAR (interpolated) = 1.15 mW/g

**WCDMA1900 Body Bottom 9400ch/Zoom Scan (5x5x7)/Cube 0:** Measurement grid: dx=8mm, dy=8mm, dz=5mm

Reference Value = 26.4 V/m; Power Drift = 0.008 dB

Peak SAR (extrapolated) = 1.61 W/kg

**SAR(1 g) = 0.978 mW/g; SAR(10 g) = 0.555 mW/g**

Maximum value of SAR (measured) = 1.08 mW/g

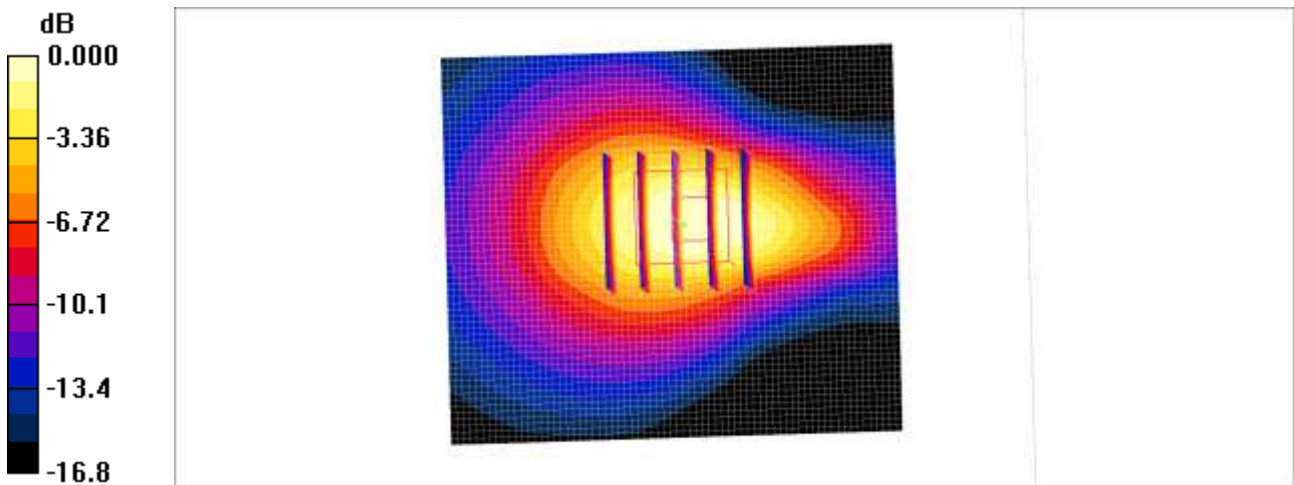

0 dB = 1.08mW/g

Test Laboratory: HCT CO., LTD  
 EUT Type: Mobile Phone  
 Liquid Temperature: 21.6 °C  
 Ambient Temperature: 22.0 °C  
 Test Date: 02/03/2016  
 Plot No.: 17

**DUT: SM-J7108; Type: Bar**

Communication System: LTE 41; Frequency: 2645 MHz; Duty Cycle: 1:1.58  
 Medium parameters used (interpolated):  $f = 2645 \text{ MHz}$ ;  $\sigma = 2.17 \text{ mho/m}$ ;  $\epsilon_r = 50.9$ ;  $\rho = 1000 \text{ kg/m}^3$   
 Phantom section: Center Section

DASY4 Configuration:

- Probe: EX3DV4 - SN3967; ConvF(7.19, 7.19, 7.19); Calibrated: 2015-12-16
- Sensor-Surface: 2mm (Mechanical Surface Detection)
- Electronics: DAE4 Sn869; Calibrated: 2015-10-07
- Phantom: Triple Flat Phantom
- Measurement SW: DASY4, V4.7 Build 80
- Postprocessing SW: SEMCAD, V1.8 Build 186

**LTE band 41 Body bottom QPSK 20MHz 1RB 0offset 41140/Area Scan (91x51x1):** Measurement grid:  $dx=12\text{mm}$ ,  $dy=12\text{mm}$   
 Maximum value of SAR (interpolated) = 1.65 mW/g

**LTE band 41 Body bottom QPSK 20MHz 1RB 0offset 41140/Zoom Scan (7x7x7)/Cube 0:** Measurement grid:  $dx=5\text{mm}$ ,  $dy=5\text{mm}$ ,  $dz=5\text{mm}$   
 Reference Value = 27.3 V/m; Power Drift = -0.078 dB  
 Peak SAR (extrapolated) = 2.27 W/kg  
**SAR(1 g) = 1.05 mW/g; SAR(10 g) = 0.488 mW/g**  
 Maximum value of SAR (measured) = 1.63 mW/g

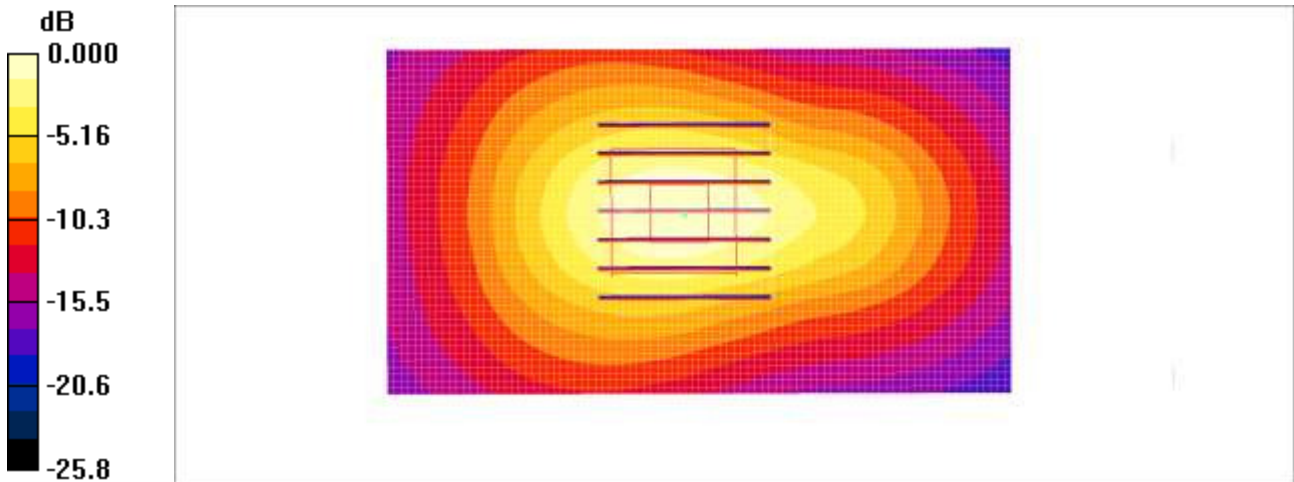

0 dB = 1.63mW/g

Test Laboratory: HCT CO., LTD  
EUT Type: Mobile Phone  
Liquid Temperature: 21.2 °C  
Ambient Temperature: 21.7 °C  
Test Date: 02/04/2016  
Plot No.: 18

**DUT: SM-J7108; Type: Bar**

Communication System: 2450MHz FCC; Frequency: 2437 MHz; Duty Cycle: 1:1  
Medium parameters used (interpolated):  $f = 2437$  MHz;  $\sigma = 1.9$  mho/m;  $\epsilon_r = 51.6$ ;  $\rho = 1000$  kg/m<sup>3</sup>  
Phantom section: Center Section

DASY4 Configuration:

- Probe: EX3DV4 - SN3967; ConvF(7.31, 7.31, 7.31); Calibrated: 2015-12-16
- Sensor-Surface: 2mm (Mechanical Surface Detection)
- Electronics: DAE4 Sn869; Calibrated: 2015-10-07
- Phantom: Triple Flat Phantom
- Measurement SW: DASY4, V4.7 Build 80
- Postprocessing SW: SEMCAD, V1.8 Build 186

**802.11b Body Front 1Mbps 6ch/Area Scan (91x151x1):** Measurement grid: dx=12mm, dy=12mm  
Maximum value of SAR (interpolated) = 0.158 mW/g

**802.11b Body Front 1Mbps 6ch/Zoom Scan (7x7x7)/Cube 0:** Measurement grid: dx=5mm, dy=5mm, dz=5mm

Reference Value = 3.94 V/m; Power Drift = -0.034 dB

Peak SAR (extrapolated) = 0.231 W/kg

**SAR(1 g) = 0.106 mW/g; SAR(10 g) = 0.054 mW/g**

Maximum value of SAR (measured) = 0.166 mW/g

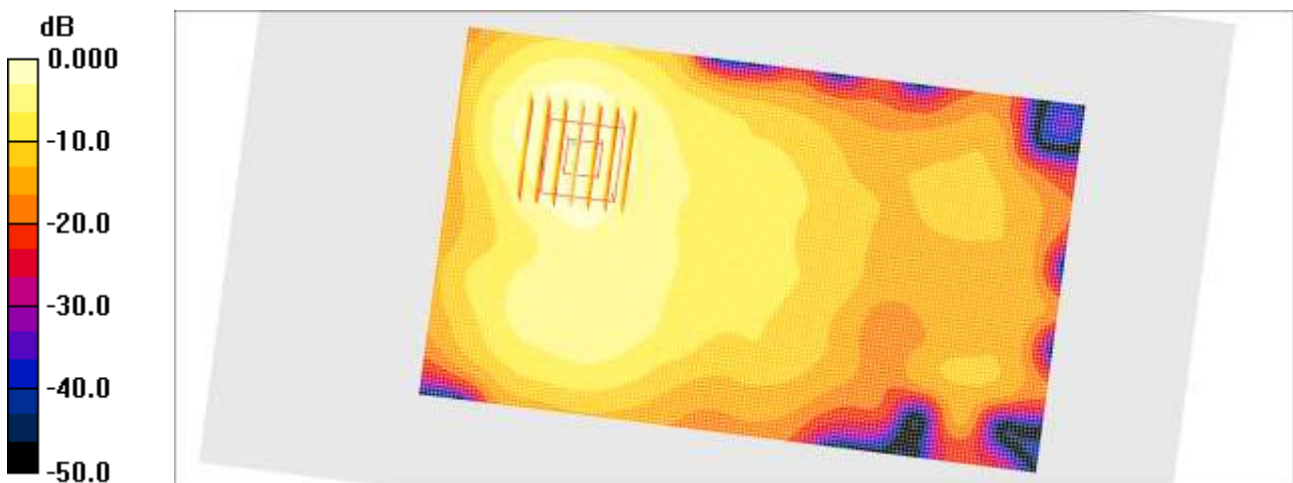

0 dB = 0.166mW/g

Test Laboratory: HCT CO., LTD  
EUT Type: Mobile Phone  
Liquid Temperature: 21.0 °C  
Ambient Temperature: 21.2 °C  
Test Date: 02/03/2016  
Plot No.: 19

**DUT: SM-J7108; Type: Bar**

Communication System: WCDMA1900; Frequency: 1880 MHz; Duty Cycle: 1:1  
Medium parameters used:  $f = 1880$  MHz;  $\sigma = 1.53$  mho/m;  $\epsilon_r = 55$ ;  $\rho = 1000$  kg/m<sup>3</sup>  
Phantom section: Center Section

DASY4 Configuration:

- Probe: EX3DV4 - SN3863; ConvF(7.48, 7.48, 7.48); Calibrated: 2015-08-27
- Sensor-Surface: 2mm (Mechanical Surface Detection)
- Electronics: DAE4 Sn652; Calibrated: 2016-01-22
- Phantom: Triple Flat Phantom
- Measurement SW: DASY4, V4.7 Build 80
- Postprocessing SW: SEMCAD, V1.8 Build 186

**WCDMA1900 Body Bottom 9400ch/Area Scan (71x61x1):** Measurement grid: dx=15mm, dy=15mm  
Maximum value of SAR (interpolated) = 1.11 mW/g

**WCDMA1900 Body Bottom 9400ch/Zoom Scan (5x5x7)/Cube 0:** Measurement grid: dx=8mm, dy=8mm, dz=5mm

Reference Value = 25.8 V/m; Power Drift = -0.039 dB

Peak SAR (extrapolated) = 1.52 W/kg

**SAR(1 g) = 0.930 mW/g; SAR(10 g) = 0.533 mW/g**

Maximum value of SAR (measured) = 1.03 mW/g

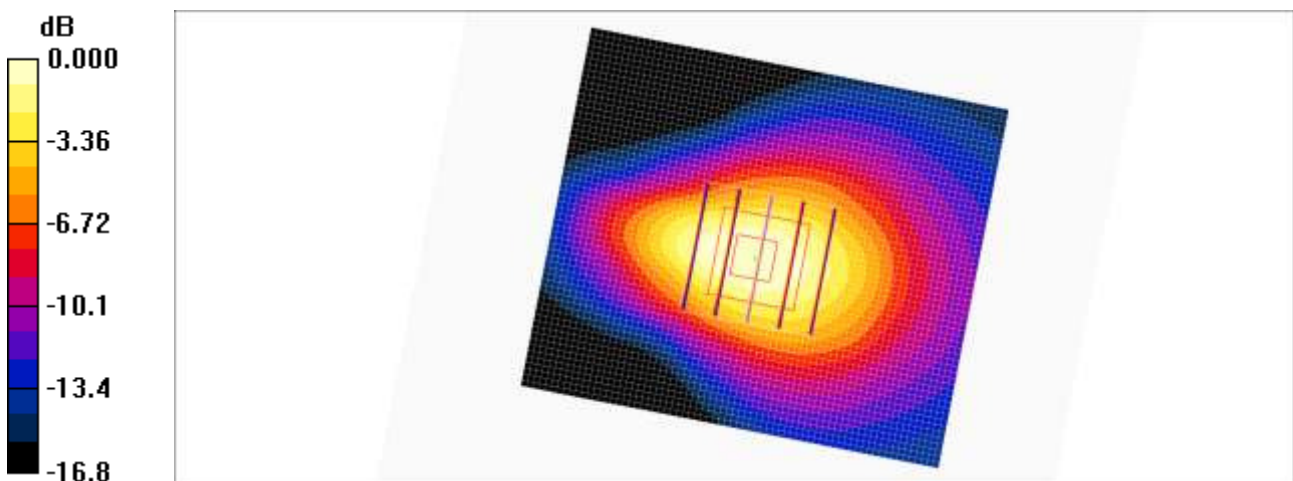

0 dB = 1.03mW/g

Test Laboratory: HCT CO., LTD  
 EUT Type: Mobile Phone  
 Liquid Temperature: 21.6 °C  
 Ambient Temperature: 22.0 °C  
 Test Date: 02/03/2016  
 Plot No.: 20

**DUT: SM-J7108; Type: Bar**

Communication System: LTE 41; Frequency: 2645 MHz; Duty Cycle: 1:1.58  
 Medium parameters used (interpolated):  $f = 2645 \text{ MHz}$ ;  $\sigma = 2.17 \text{ mho/m}$ ;  $\epsilon_r = 50.9$ ;  $\rho = 1000 \text{ kg/m}^3$   
 Phantom section: Center Section

DASY4 Configuration:

- Probe: EX3DV4 - SN3967; ConvF(7.19, 7.19, 7.19); Calibrated: 2015-12-16
- Sensor-Surface: 2mm (Mechanical Surface Detection)
- Electronics: DAE4 Sn869; Calibrated: 2015-10-07
- Phantom: Triple Flat Phantom
- Measurement SW: DASY4, V4.7 Build 80
- Postprocessing SW: SEMCAD, V1.8 Build 186

**LTE band 41 Body bottom QPSK 20MHz 1RB 0offset 41140/Area Scan (91x51x1):** Measurement grid:  $dx=12\text{mm}$ ,  $dy=12\text{mm}$   
 Maximum value of SAR (interpolated) = 1.64 mW/g

**LTE band 41 Body bottom QPSK 20MHz 1RB 0offset 41140/Zoom Scan (7x7x7)/Cube 0:** Measurement grid:  $dx=5\text{mm}$ ,  $dy=5\text{mm}$ ,  $dz=5\text{mm}$   
 Reference Value = 27.2 V/m; Power Drift = -0.004 dB  
 Peak SAR (extrapolated) = 2.28 W/kg  
**SAR(1 g) = 1.05 mW/g; SAR(10 g) = 0.478 mW/g**  
 Maximum value of SAR (measured) = 1.63 mW/g

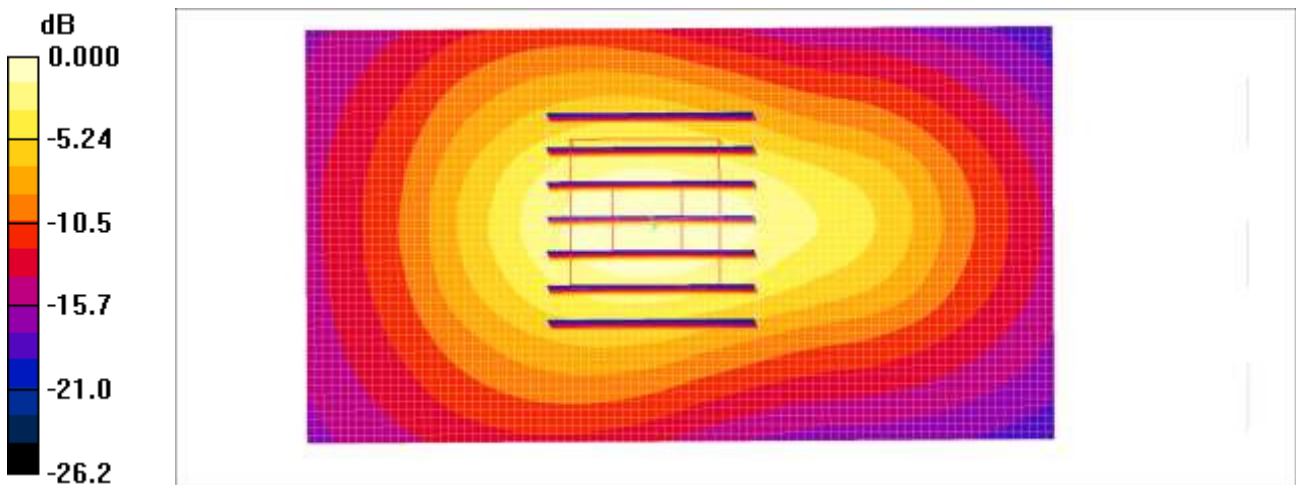

0 dB = 1.63mW/g

## Attachment 2. – Dipole Verification Plots

**■ Verification Data (835 MHz Head)**

Test Laboratory: HCT CO., LTD  
 Input Power 100 mW (20 dBm)  
 Liquid Temp: 20.5 °C  
 Test Date: 02/01/2016

**DUT: Dipole 835 MHz; Type: D835V2**

Communication System: CW; Frequency: 835 MHz; Duty Cycle: 1:1  
 Medium parameters used:  $f = 835 \text{ MHz}$ ;  $\sigma = 0.899 \text{ mho/m}$ ;  $\epsilon_r = 42.7$ ;  $\rho = 1000 \text{ kg/m}^3$   
 Phantom section: Flat Section

DASY4 Configuration:

- Probe: EX3DV4 - SN3863; ConvF(9.46, 9.46, 9.46); Calibrated: 2015-08-27
- Sensor-Surface: 2mm (Mechanical Surface Detection)
- Electronics: DAE4 Sn652; Calibrated: 2016-01-22
- Phantom: SAM
- Measurement SW: DASY4, V4.7 Build 80
- Postprocessing SW: SEMCAD, V1.8 Build 186

**Verification 835 MHz/Area Scan (61x81x1):** Measurement grid:  $dx=15\text{mm}$ ,  $dy=15\text{mm}$   
 Maximum value of SAR (interpolated) = 1.00 mW/g

**Verification 835 MHz/Zoom Scan (5x5x7)/Cube 0:** Measurement grid:  $dx=8\text{mm}$ ,  $dy=8\text{mm}$ ,  $dz=5\text{mm}$   
 Reference Value = 33.6 V/m; Power Drift = -0.031 dB  
 Peak SAR (extrapolated) = 1.35 W/kg  
**SAR(1 g) = 0.921 mW/g; SAR(10 g) = 0.606 mW/g**  
 Maximum value of SAR (measured) = 0.995 mW/g

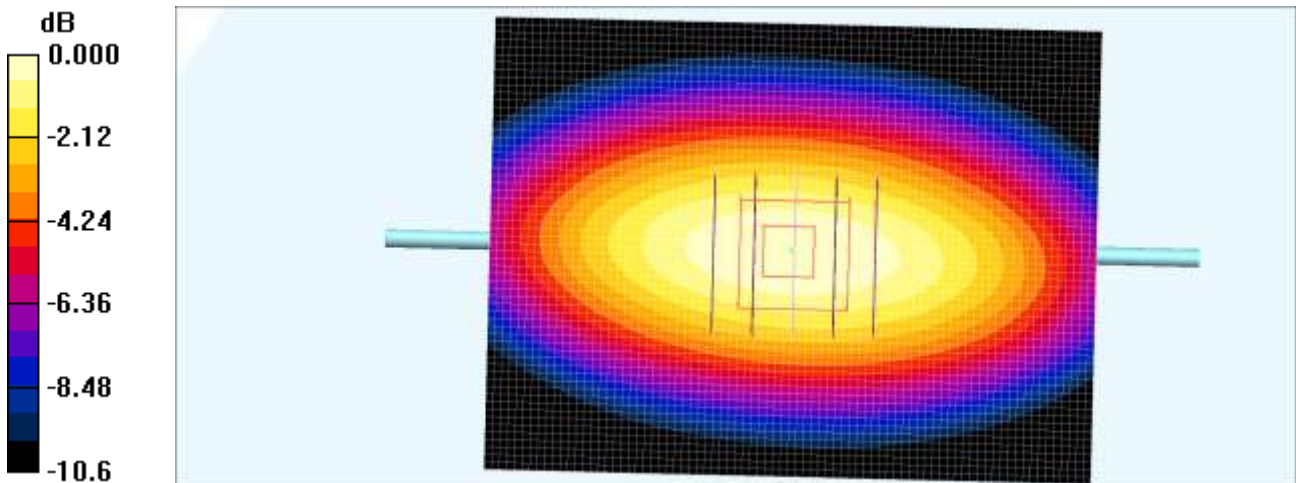

0 dB = 0.995mW/g

## ■ Verification Data (835 MHz Body)

Test Laboratory: HCT CO., LTD  
Input Power 100 mW (20 dBm)  
Liquid Temp: 20.7 °C  
Test Date: 02/02/2016

### DUT: Dipole 835 MHz; Type: D835V2

Communication System: CW; Frequency: 835 MHz; Duty Cycle: 1:1  
Medium parameters used:  $f = 835 \text{ MHz}$ ;  $\sigma = 0.981 \text{ mho/m}$ ;  $\epsilon_r = 54.4$ ;  $\rho = 1000 \text{ kg/m}^3$   
Phantom section: Center Section

DASY4 Configuration:

- Probe: EX3DV4 - SN3863; ConvF(9.4, 9.4, 9.4); Calibrated: 2015-08-27
- Sensor-Surface: 2mm (Mechanical Surface Detection)
- Electronics: DAE4 Sn652; Calibrated: 2016-01-22
- Phantom: Triple Flat Phantom
- Measurement SW: DASY4, V4.7 Build 80
- Postprocessing SW: SEMCAD, V1.8 Build 186

**Verification 835 MHz/Area Scan (111x61x1):** Measurement grid: dx=15mm, dy=15mm  
Maximum value of SAR (interpolated) = 1.06 mW/g

**Verification 835 MHz/Zoom Scan (5x5x7)/Cube 0:** Measurement grid: dx=8mm, dy=8mm, dz=5mm  
Reference Value = 32.8 V/m; Power Drift = 0.066 dB  
Peak SAR (extrapolated) = 1.44 W/kg  
**SAR(1 g) = 0.981 mW/g; SAR(10 g) = 0.640 mW/g**  
Maximum value of SAR (measured) = 1.06 mW/g

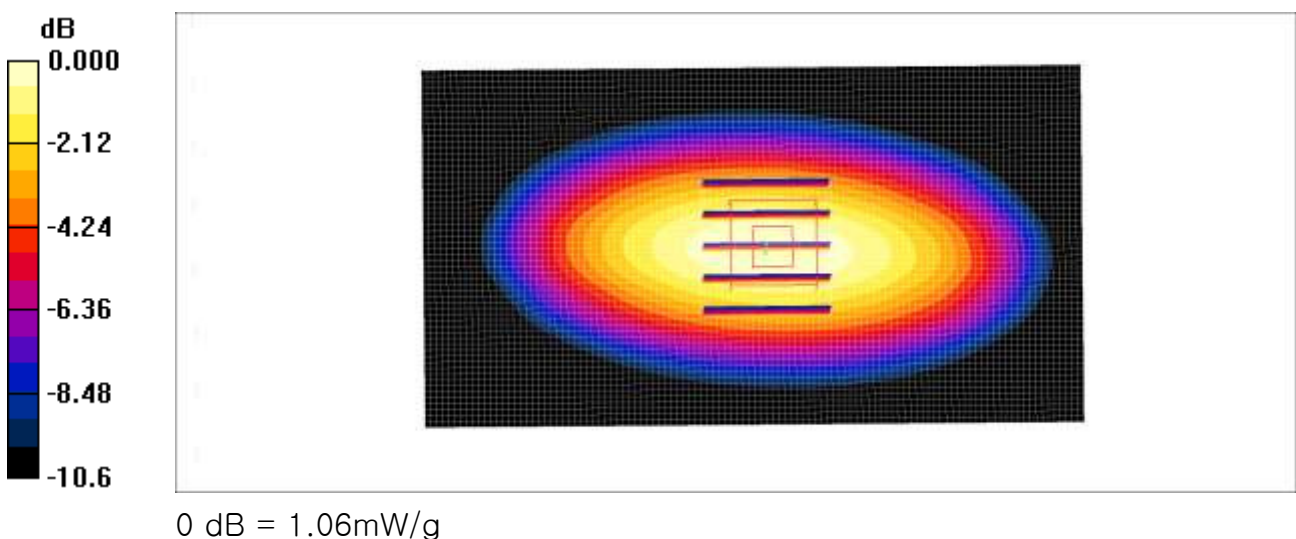

## ■ Verification Data (1 900 MHz Head)

Test Laboratory: HCT CO., LTD  
Input Power: 100 mW (20 dBm)  
Liquid Temp: 22.0 °C  
Test Date: 02/01/2016

### DUT: Dipole 1900 MHz; Type: D1900V2

Communication System: CW; Frequency: 1900 MHz; Duty Cycle: 1:1  
Medium parameters used:  $f = 1900$  MHz;  $\sigma = 1.4$  mho/m;  $\epsilon_r = 39.3$ ;  $\rho = 1000$  kg/m<sup>3</sup>  
Phantom section: Flat Section

DASY4 Configuration:

- Probe: EX3DV4 - SN3967; ConvF(8.11, 8.11, 8.11); Calibrated: 2015-12-16
- Sensor-Surface: 2mm (Mechanical Surface Detection)
- Electronics: DAE4 Sn869; Calibrated: 2015-10-07
- Phantom; Type: SAM
- Measurement SW: DASY4, V4.7 Build 80
- Postprocessing SW: SEMCAD, V1.8 Build 186

**1900MHz Verification/Area Scan (61x61x1):** Measurement grid: dx=15mm, dy=15mm  
Maximum value of SAR (interpolated) = 4.79 mW/g

**1900MHz Verification/Zoom Scan (5x5x7)/Cube 0:** Measurement grid: dx=8mm, dy=8mm, dz=5mm  
Reference Value = 57.2 V/m; Power Drift = 0.051 dB

Peak SAR (extrapolated) = 7.70 W/kg

**SAR(1 g) = 4.16 mW/g; SAR(10 g) = 2.17 mW/g**

Maximum value of SAR (measured) = 4.61 mW/g

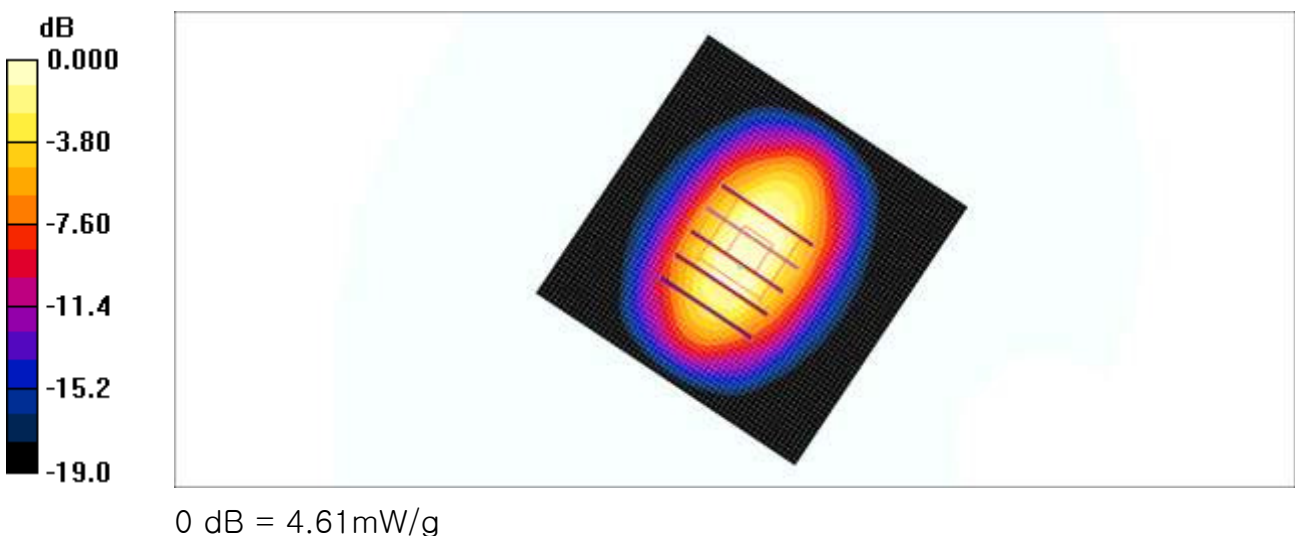

## ■ Verification Data (1 900 MHz Body)

Test Laboratory: HCT CO., LTD  
 Input Power 100 mW (20 dBm)  
 Liquid Temp: 21.0 °C  
 Test Date: 02/03/2016

### DUT: Dipole 1900 MHz; Type: D1900V2

Communication System: CW; Frequency: 1900 MHz; Duty Cycle: 1:1  
 Medium parameters used:  $f = 1900 \text{ MHz}$ ;  $\sigma = 1.55 \text{ mho/m}$ ;  $\epsilon_r = 54.9$ ;  $\rho = 1000 \text{ kg/m}^3$   
 Phantom section: Center Section

#### DASY4 Configuration:

- Probe: EX3DV4 - SN3863; ConvF(7.48, 7.48, 7.48); Calibrated: 2015-08-27
- Sensor-Surface: 2mm (Mechanical Surface Detection)
- Electronics: DAE4 Sn652; Calibrated: 2016-01-22
- Phantom: Triple Flat Phantom
- Measurement SW: DASY4, V4.7 Build 80
- Postprocessing SW: SEMCAD, V1.8 Build 186

**Verification 1900 MHz/Area Scan (61x61x1):** Measurement grid:  $dx=15\text{mm}$ ,  $dy=15\text{mm}$   
 Maximum value of SAR (interpolated) = 6.09 mW/g

**Verification 1900 MHz/Zoom Scan (5x5x7)/Cube 0:** Measurement grid:  $dx=8\text{mm}$ ,  $dy=8\text{mm}$ ,  $dz=5\text{mm}$   
 Reference Value = 40.9 V/m; Power Drift = -0.063 dB  
 Peak SAR (extrapolated) = 8.41 W/kg  
**SAR(1 g) = 4.08 mW/g; SAR(10 g) = 1.93 mW/g**  
 Maximum value of SAR (measured) = 4.61 mW/g

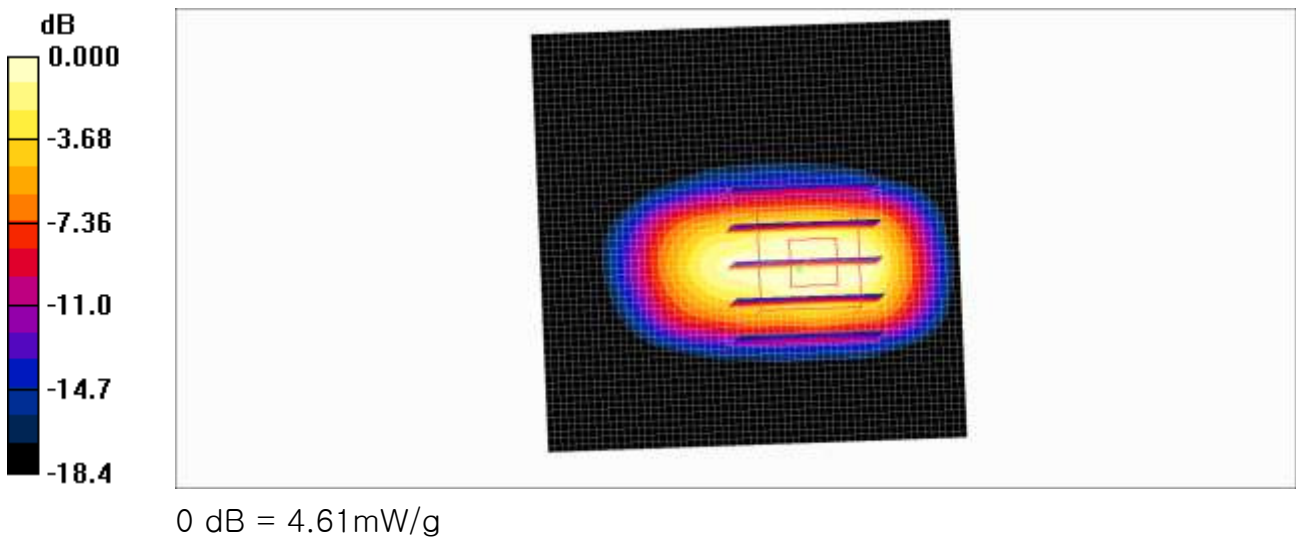

## ■ Verification Data (2 450 MHz Head)

Test Laboratory: HCT CO., LTD  
Input Power 100 mW (20 dBm)  
Liquid Temp: 21.2 °C  
Test Date: 02/04/2016

### DUT: Dipole 2450 MHz; Type: D2450V2

Communication System: CW; Frequency: 2450 MHz; Duty Cycle: 1:1  
Medium parameters used:  $f = 2450$  MHz;  $\sigma = 1.83$  mho/m;  $\epsilon_r = 38.2$ ;  $\rho = 1000$  kg/m<sup>3</sup>  
Phantom section: Flat Section

DASY4 Configuration:

- Probe: EX3DV4 - SN3967; ConvF(7.42, 7.42, 7.42); Calibrated: 2015-12-16
- Sensor-Surface: 2mm (Mechanical Surface Detection)
- Electronics: DAE4 Sn869; Calibrated: 2015-10-07
- Phantom ; Type: SAM
- Measurement SW: DASY4, V4.7 Build 80
- Postprocessing SW: SEMCAD, V1.8 Build 186

**2450MHz verification/Area Scan (81x81x1):** Measurement grid: dx=12mm, dy=12mm  
Maximum value of SAR (interpolated) = 8.55 mW/g

**2450MHz verification/Zoom Scan (7x7x7)/Cube 0:** Measurement grid: dx=5mm, dy=5mm, dz=5mm  
Reference Value = 58.2 V/m; Power Drift = -0.012 dB

Peak SAR (extrapolated) = 12.1 W/kg

**SAR(1 g) = 5.4 mW/g; SAR(10 g) = 2.41 mW/g**

Maximum value of SAR (measured) = 8.55 mW/g

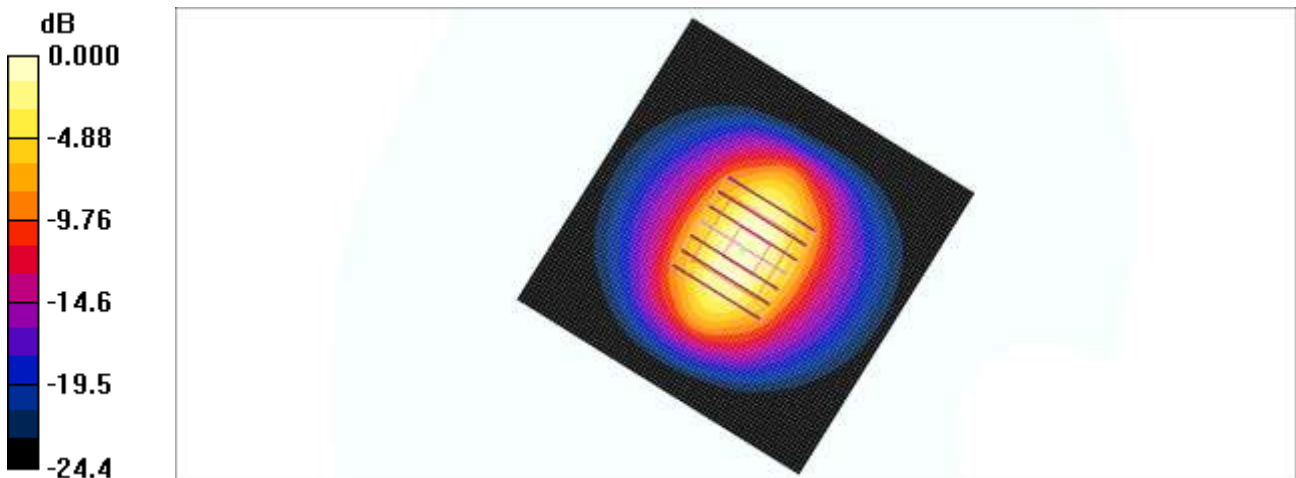

0 dB = 8.55mW/g

## ■ Verification Data (2 450 MHz Body)

Test Laboratory: HCT CO., LTD  
 Input Power 100 mW (20 dBm)  
 Liquid Temp: 21.2 °C  
 Test Date: 02/04/2016

### DUT: Dipole 2450 MHz; Type: D2450V2

Communication System: CW; Frequency: 2450 MHz; Duty Cycle: 1:1  
 Medium parameters used:  $f = 2450 \text{ MHz}$ ;  $\sigma = 1.92 \text{ mho/m}$ ;  $\epsilon_r = 51.6$ ;  $\rho = 1000 \text{ kg/m}^3$   
 Phantom section: Center Section

#### DASY4 Configuration:

- Probe: EX3DV4 - SN3967; ConvF(7.31, 7.31, 7.31); Calibrated: 2015-12-16
- Sensor-Surface: 2mm (Mechanical Surface Detection)
- Electronics: DAE4 Sn869; Calibrated: 2015-10-07
- Phantom: Triple Flat Phantom
- Measurement SW: DASY4, V4.7 Build 80
- Postprocessing SW: SEMCAD, V1.8 Build 186

**2450MHz Verification/Area Scan (81x81x1):** Measurement grid: dx=12mm, dy=12mm  
 Maximum value of SAR (interpolated) = 8.68 mW/g

**2450MHz Verification/Zoom Scan (7x7x7)/Cube 0:** Measurement grid: dx=5mm, dy=5mm, dz=5mm  
 Reference Value = 52.1 V/m; Power Drift = 0.020 dB  
 Peak SAR (extrapolated) = 12.5 W/kg  
**SAR(1 g) = 5.43 mW/g; SAR(10 g) = 2.34 mW/g**  
 Maximum value of SAR (measured) = 8.73 mW/g

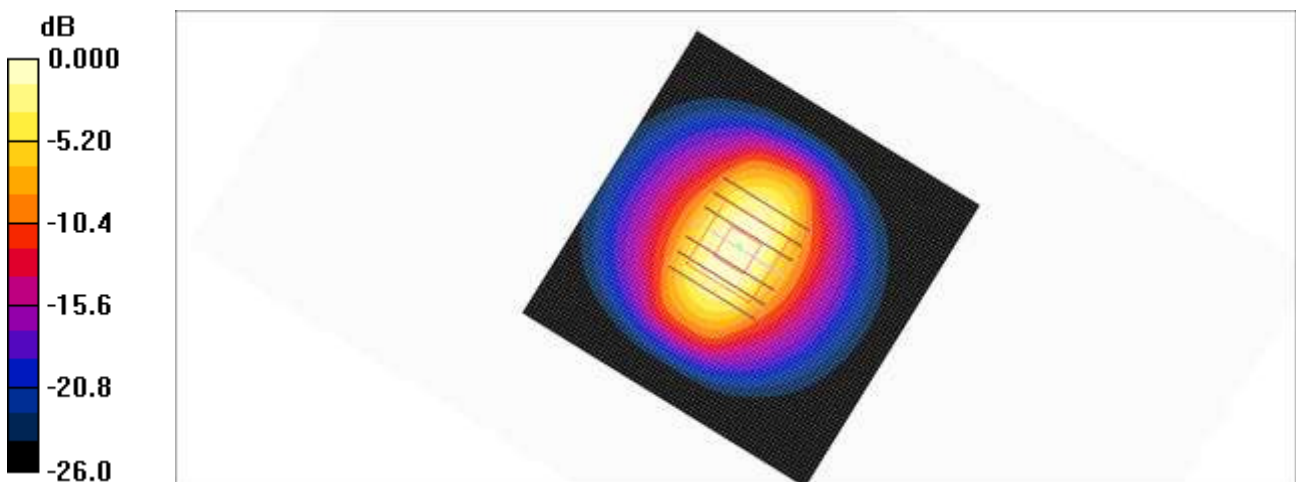

0 dB = 8.73mW/g

## ■ Verification Data (2 600 MHz Head)

Test Laboratory: HCT CO., LTD  
 Input Power 100 mW (20 dBm)  
 Liquid Temp: 21.5 °C  
 Test Date: 02/02/2016

### DUT: Dipole 2600 MHz; Type: D2600V2

Communication System: CW; Frequency: 2600 MHz; Duty Cycle: 1:1  
 Medium parameters used:  $f = 2600 \text{ MHz}$ ;  $\sigma = 2 \text{ mho/m}$ ;  $\epsilon_r = 37.6$ ;  $\rho = 1000 \text{ kg/m}^3$   
 Phantom section: Flat Section

#### DASY4 Configuration:

- Probe: EX3DV4 - SN3967; ConvF(7.17, 7.17, 7.17); Calibrated: 2015-12-16
- Sensor-Surface: 2mm (Mechanical Surface Detection)
- Electronics: DAE4 Sn869; Calibrated: 2015-10-07
- Phantom: Type: SAM
- Measurement SW: DASY4, V4.7 Build 80
- Postprocessing SW: SEMCAD, V1.8 Build 186

**2600MHz Verification/Area Scan (81x81x1):** Measurement grid:  $dx=12\text{mm}$ ,  $dy=12\text{mm}$   
 Maximum value of SAR (interpolated) = 9.09 mW/g

**2600MHz Verification/Zoom Scan (7x7x7)/Cube 0:** Measurement grid:  $dx=5\text{mm}$ ,  $dy=5\text{mm}$ ,  $dz=5\text{mm}$   
 Reference Value = 57.3 V/m; Power Drift = -0.023 dB

Peak SAR (extrapolated) = 12.8 W/kg

**SAR(1 g) = 5.71 mW/g; SAR(10 g) = 2.54 mW/g**

Maximum value of SAR (measured) = 9.07 mW/g

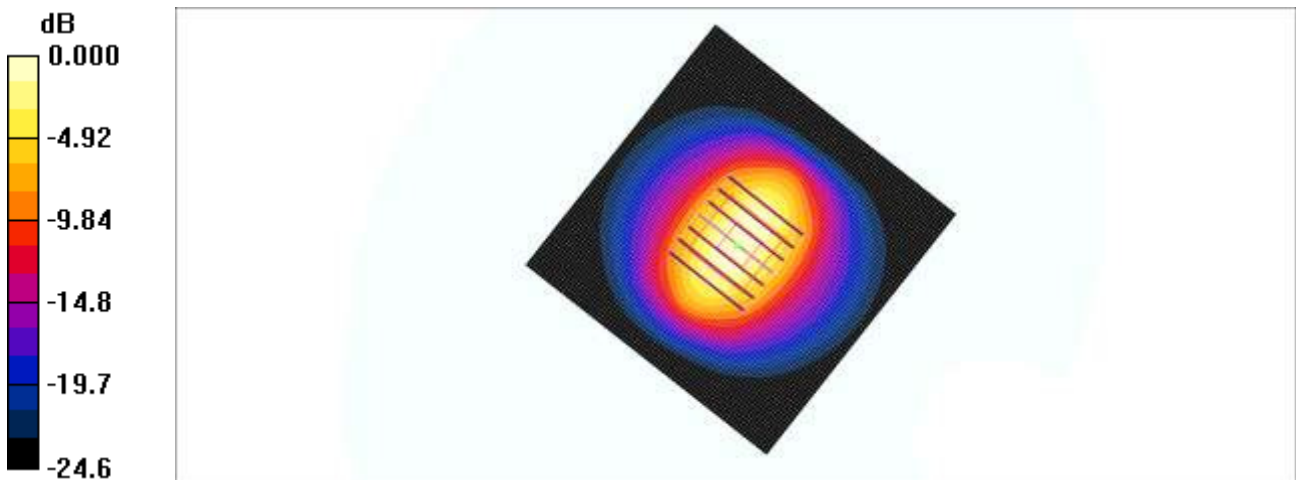

0 dB = 9.07mW/g

## ■ Verification Data (2 600 MHz Body)

Test Laboratory: HCT CO., LTD  
 Input Power 100 mW (20 dBm)  
 Liquid Temp: 21.6 °C  
 Test Date: 02/03/2016

### DUT: Dipole 2600 MHz; Type: D2600V2

Communication System: CW; Frequency: 2600 MHz; Duty Cycle: 1:1  
 Medium parameters used:  $f = 2600 \text{ MHz}$ ;  $\sigma = 2.12 \text{ mho/m}$ ;  $\epsilon_r = 51$ ;  $\rho = 1000 \text{ kg/m}^3$   
 Phantom section: Center Section

#### DASY4 Configuration:

- Probe: EX3DV4 - SN3967; ConvF(7.19, 7.19, 7.19); Calibrated: 2015-12-16
- Sensor-Surface: 2mm (Mechanical Surface Detection)
- Electronics: DAE4 Sn869; Calibrated: 2015-10-07
- Phantom: Triple Flat Phantom
- Measurement SW: DASY4, V4.7 Build 80
- Postprocessing SW: SEMCAD, V1.8 Build 186

**Verification 2600MHz/Area Scan (81x81x1):** Measurement grid:  $dx=12\text{mm}$ ,  $dy=12\text{mm}$   
 Maximum value of SAR (interpolated) = 8.48 mW/g

**Verification 2600MHz/Zoom Scan (7x7x7)/Cube 0:** Measurement grid:  $dx=5\text{mm}$ ,  $dy=5\text{mm}$ ,  $dz=5\text{mm}$   
 Reference Value = 52.2 V/m; Power Drift = 0.031 dB  
 Peak SAR (extrapolated) = 11.7 W/kg  
**SAR(1 g) = 5.54 mW/g; SAR(10 g) = 2.52 mW/g**  
 Maximum value of SAR (measured) = 8.63 mW/g

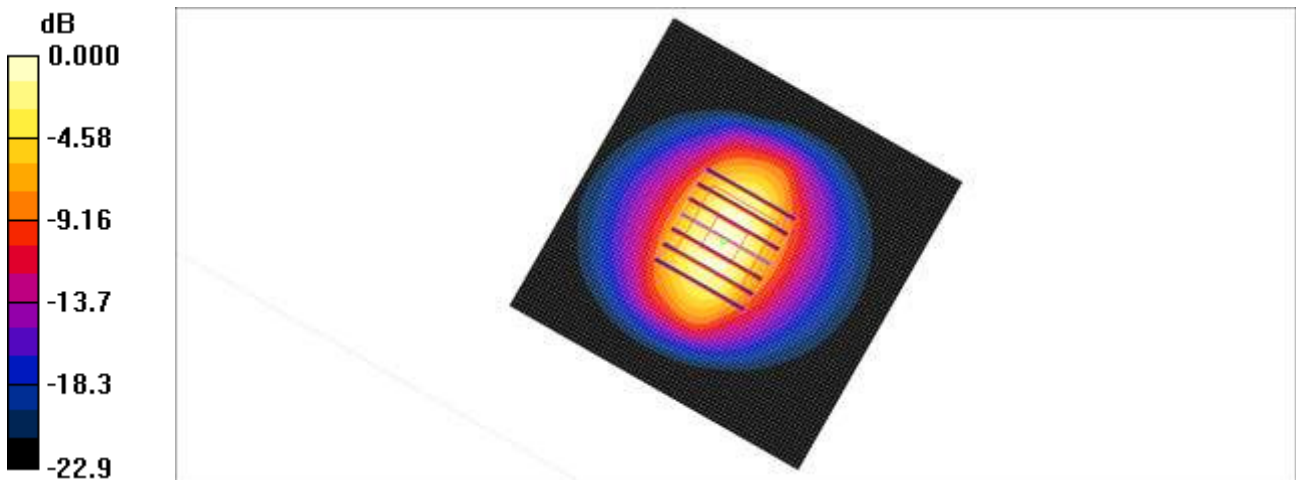

0 dB = 8.63mW/g

## Attachment 3. – Probe Calibration Data

**Calibration Laboratory of  
Schmid & Partner  
Engineering AG**  
Zeughausstrasse 43, 8004 Zurich, Switzerland



**S** Schweizerischer Kalibrierdienst  
**C** Service suisse d'étalonnage  
**S** Servizio svizzero di taratura  
**S** Swiss Calibration Service

Accredited by the Swiss Accreditation Service (SAS)  
The Swiss Accreditation Service is one of the signatories to the EA  
Multilateral Agreement for the recognition of calibration certificates

Accreditation No.: **SCS 0108**

Client: **HCT (Dymstec)**

Certificate No: **EX3-3863\_Aug15**

### CALIBRATION CERTIFICATE

Object: **EX3DV4 - SN:3863**

Calibration procedure(s): **QA CAL-01.v9, QA CAL-12.v9, QA CAL-14.v4, QA CAL-23.v5,  
QA CAL-25.v6  
Calibration procedure for dosimetric E-field probes**



Calibration date: **August 27, 2015**

This calibration certificate documents the traceability to national standards, which realize the physical units of measurements (SI).  
The measurements and the uncertainties with confidence probability are given on the following pages and are part of the certificate.

All calibrations have been conducted in the closed laboratory facility; environment temperature (22 ± 3)°C and humidity < 70%.

Calibration Equipment used (M&TE critical for calibration)

Primary Standards	ID	Cal Date (Certificate No.)	Scheduled Calibration
Power meter E4419B	GB41293874	01-Apr-15 (No. 217-02128)	Mar-16
Power sensor E4412A	MY41498087	01-Apr-15 (No. 217-02128)	Mar-16
Reference 3 dB Attenuator	SN: S5054 (3c)	01-Apr-15 (No. 217-02129)	Mar-16
Reference 20 dB Attenuator	SN: S5277 (20x)	01-Apr-15 (No. 217-02132)	Mar-16
Reference 30 dB Attenuator	SN: S5129 (30b)	01-Apr-15 (No. 217-02133)	Mar-16
Reference Probe ES3DV2	SN: 3013	30-Dec-14 (No. ES3-3013_Dec14)	Dec-15
DAE4	SN: 660	14-Jan-15 (No. DAE4-660_Jan15)	Jan-16
Secondary Standards	ID	Check Date (in house)	Scheduled Check
RF generator HP 8648C	US3642U01700	4-Aug-99 (in house check Apr-13)	In house check: Apr-16
Network Analyzer HP 8753E	US37390585	18-Oct-01 (in house check Oct-14)	In house check: Oct-15

Calibrated by:	Name <b>Jeton Kastrati</b>	Function <b>Laboratory Technician</b>	Signature 
Approved by:	Name <b>Katja Pokovic</b>	Function <b>Technical Manager</b>	Signature 

Issued: August 28, 2015

This calibration certificate shall not be reproduced except in full without written approval of the laboratory.

Calibration Laboratory of  
Schmid & Partner  
Engineering AG  
Zeughausstrasse 43, 8004 Zurich, Switzerland



S Schweizerischer Kalibrierdienst  
C Service suisse d'étalonnage  
S Servizio svizzero di taratura  
S Swiss Calibration Service

Accredited by the Swiss Accreditation Service (SAS)  
The Swiss Accreditation Service is one of the signatories to the EA  
Multilateral Agreement for the recognition of calibration certificates

Accreditation No.: SCS 0108

**Glossary:**

TSL	tissue simulating liquid
NORM <sub>x,y,z</sub>	sensitivity in free space
ConvF	sensitivity in TSL / NORM <sub>x,y,z</sub>
DCP	diode compression point
CF	crest factor (1/duty_cycle) of the RF signal
A, B, C, D	modulation dependent linearization parameters
Polarization $\varphi$	$\varphi$ rotation around probe axis
Polarization $\theta$	$\theta$ rotation around an axis that is in the plane normal to probe axis (at measurement center), i.e., $\theta = 0$ is normal to probe axis
Connector Angle	information used in DASY system to align probe sensor X to the robot coordinate system

**Calibration is Performed According to the Following Standards:**

- a) IEEE Std 1528-2013, "IEEE Recommended Practice for Determining the Peak Spatial-Averaged Specific Absorption Rate (SAR) in the Human Head from Wireless Communications Devices: Measurement Techniques", June 2013
- b) IEC 62209-1, "Procedure to measure the Specific Absorption Rate (SAR) for hand-held devices used in close proximity to the ear (frequency range of 300 MHz to 3 GHz)", February 2005
- c) IEC 62209-2, "Procedure to determine the Specific Absorption Rate (SAR) for wireless communication devices used in close proximity to the human body (frequency range of 30 MHz to 6 GHz)", March 2010
- d) KDB 865664, "SAR Measurement Requirements for 100 MHz to 6 GHz"

**Methods Applied and Interpretation of Parameters:**

- NORM<sub>x,y,z</sub>: Assessed for E-field polarization  $\theta = 0$  ( $f \leq 900$  MHz in TEM-cell;  $f > 1800$  MHz: R22 waveguide). NORM<sub>x,y,z</sub> are only intermediate values, i.e., the uncertainties of NORM<sub>x,y,z</sub> does not affect the E<sup>2</sup>-field uncertainty inside TSL (see below ConvF).
- NORM(f)<sub>x,y,z</sub> = NORM<sub>x,y,z</sub> \* frequency\_response (see Frequency Response Chart). This linearization is implemented in DASY4 software versions later than 4.2. The uncertainty of the frequency response is included in the stated uncertainty of ConvF.
- DCP<sub>x,y,z</sub>: DCP are numerical linearization parameters assessed based on the data of power sweep with CW signal (no uncertainty required). DCP does not depend on frequency nor media.
- PAR: PAR is the Peak to Average Ratio that is not calibrated but determined based on the signal characteristics
- Ax,y,z; Bx,y,z; Cx,y,z; Dx,y,z; VRx,y,z: A, B, C, D are numerical linearization parameters assessed based on the data of power sweep for specific modulation signal. The parameters do not depend on frequency nor media. VR is the maximum calibration range expressed in RMS voltage across the diode.
- ConvF and Boundary Effect Parameters: Assessed in flat phantom using E-field (or Temperature Transfer Standard for  $f \leq 800$  MHz) and inside waveguide using analytical field distributions based on power measurements for  $f > 800$  MHz. The same setups are used for assessment of the parameters applied for boundary compensation (alpha, depth) of which typical uncertainty values are given. These parameters are used in DASY4 software to improve probe accuracy close to the boundary. The sensitivity in TSL corresponds to NORM<sub>x,y,z</sub> \* ConvF whereby the uncertainty corresponds to that given for ConvF. A frequency dependent ConvF is used in DASY version 4.4 and higher which allows extending the validity from  $\pm 50$  MHz to  $\pm 100$  MHz.
- Spherical isotropy (3D deviation from isotropy): in a field of low gradients realized using a flat phantom exposed by a patch antenna.
- Sensor Offset: The sensor offset corresponds to the offset of virtual measurement center from the probe tip (on probe axis). No tolerance required.
- Connector Angle: The angle is assessed using the information gained by determining the NORM<sub>x</sub> (no uncertainty required).

EX3DV4 – SN:3863

August 27, 2015

# Probe EX3DV4

## SN:3863

Manufactured: February 2, 2012  
Calibrated: August 27, 2015

Calibrated for DASY/EASY Systems  
(Note: non-compatible with DASY2 system!)

EX3DV4-- SN:3863

August 27, 2015

## DASY/EASY - Parameters of Probe: EX3DV4 - SN:3863

### Basic Calibration Parameters

	Sensor X	Sensor Y	Sensor Z	Unc (k=2)
Norm ( $\mu\text{V}/(\text{V}/\text{m})^2$ ) <sup>A</sup>	0.37	0.35	0.45	$\pm 10.1\%$
DCP (mV) <sup>B</sup>	101.9	103.9	98.9	

### Modulation Calibration Parameters

UID	Communication System Name		A dB	B dB $\sqrt{\mu\text{V}}$	C	D dB	VR mV	Unc <sup>C</sup> (k=2)
0	CW	X	0.0	0.0	1.0	0.00	131.8	$\pm 2.7\%$
		Y	0.0	0.0	1.0		129.9	
		Z	0.0	0.0	1.0		126.4	

The reported uncertainty of measurement is stated as the standard uncertainty of measurement multiplied by the coverage factor  $k=2$ , which for a normal distribution corresponds to a coverage probability of approximately 95%.

<sup>A</sup> The uncertainties of Norm X,Y,Z do not affect the E<sup>2</sup>-field uncertainty inside TSL (see Pages 5 and 6).

<sup>B</sup> Numerical linearization parameter; uncertainty not required.

<sup>C</sup> Uncertainty is determined using the max. deviation from linear response applying rectangular distribution and is expressed for the square of the field value.

EX3DV4- SN:3863

August 27, 2015

## DASY/EASY - Parameters of Probe: EX3DV4 - SN:3863

### Calibration Parameter Determined in Head Tissue Simulating Media

f (MHz) <sup>C</sup>	Relative Permittivity <sup>F</sup>	Conductivity (S/m) <sup>F</sup>	ConvF X	ConvF Y	ConvF Z	Alpha <sup>G</sup>	Depth <sup>H</sup> (mm)	Unc (k=2)
150	52.3	0.76	11.89	11.89	11.89	0.00	1.00	± 13.3 %
450	43.5	0.87	10.31	10.31	10.31	0.17	1.30	± 13.3 %
750	41.9	0.89	9.83	9.83	9.83	0.24	1.21	± 12.0 %
835	41.5	0.90	9.46	9.46	9.46	0.21	1.30	± 12.0 %
900	41.5	0.97	9.28	9.28	9.28	0.26	1.11	± 12.0 %
1450	40.5	1.20	8.31	8.31	8.31	0.15	1.81	± 12.0 %
1750	40.1	1.37	8.18	8.18	8.18	0.36	0.90	± 12.0 %
1900	40.0	1.40	7.84	7.84	7.84	0.21	1.07	± 12.0 %
1950	40.0	1.40	7.60	7.60	7.60	0.31	0.80	± 12.0 %
2450	39.2	1.80	7.04	7.04	7.04	0.27	0.98	± 12.0 %
2600	39.0	1.96	6.84	6.84	6.84	0.27	1.04	± 12.0 %
3500	37.9	2.91	6.77	6.77	6.77	0.38	1.06	± 13.1 %
5250	35.9	4.71	4.94	4.94	4.94	0.35	1.80	± 13.1 %
5600	35.5	5.07	4.44	4.44	4.44	0.45	1.80	± 13.1 %
5750	35.4	5.22	4.65	4.65	4.65	0.45	1.80	± 13.1 %

<sup>C</sup> Frequency validity above 300 MHz of ± 100 MHz only applies for DASY v4.4 and higher (see Page 2), else it is restricted to ± 50 MHz. The uncertainty is the RSS of the ConvF uncertainty at calibration frequency and the uncertainty for the indicated frequency band. Frequency validity below 300 MHz is ± 10, 25, 40, 50 and 70 MHz for ConvF assessments at 30, 64, 128, 150 and 220 MHz respectively. Above 5 GHz frequency validity can be extended to ± 110 MHz.

<sup>F</sup> At frequencies below 3 GHz, the validity of tissue parameters ( $\epsilon$  and  $\sigma$ ) can be relaxed to ± 10% if liquid compensation formula is applied to measured SAR values. At frequencies above 3 GHz, the validity of tissue parameters ( $\epsilon$  and  $\sigma$ ) is restricted to ± 5%. The uncertainty is the RSS of the ConvF uncertainty for indicated target tissue parameters.

<sup>H</sup> Alpha/Depth are determined during calibration. SPEAG warrants that the remaining deviation due to the boundary effect after compensation is always less than ± 1% for frequencies below 3 GHz and below ± 2% for frequencies between 3-6 GHz at any distance larger than half the probe tip diameter from the boundary.

EX3DV4- SN:3863

August 27, 2015

## DASY/EASY - Parameters of Probe: EX3DV4 - SN:3863

### Calibration Parameter Determined in Body Tissue Simulating Media

f (MHz) <sup>C</sup>	Relative Permittivity <sup>F</sup>	Conductivity (S/m) <sup>F</sup>	ConvF X	ConvF Y	ConvF Z	Alpha <sup>G</sup>	Depth <sup>H</sup> (mm)	Unc (k=2)
150	61.9	0.80	11.68	11.68	11.68	0.00	1.00	± 13.3 %
450	56.7	0.94	10.67	10.67	10.67	0.10	1.20	± 13.3 %
750	55.5	0.96	9.76	9.76	9.76	0.25	1.16	± 12.0 %
835	55.2	0.97	9.40	9.40	9.40	0.23	1.44	± 12.0 %
1750	53.4	1.49	7.73	7.73	7.73	0.24	1.01	± 12.0 %
1900	53.3	1.52	7.48	7.48	7.48	0.39	0.80	± 12.0 %
2450	52.7	1.95	7.11	7.11	7.11	0.31	0.80	± 12.0 %
2600	52.5	2.16	6.97	6.97	6.97	0.33	0.80	± 12.0 %
5250	48.9	5.36	4.44	4.44	4.44	0.40	1.90	± 13.1 %
5600	48.5	5.77	3.77	3.77	3.77	0.50	1.90	± 13.1 %
5750	48.3	5.94	4.08	4.08	4.08	0.50	1.90	± 13.1 %

<sup>C</sup> Frequency validity above 300 MHz of ± 100 MHz only applies for DASY v4.4 and higher (see Page 2), else it is restricted to ± 50 MHz. The uncertainty is the RSS of the ConvF uncertainty at calibration frequency and the uncertainty for the indicated frequency band. Frequency validity below 300 MHz is ± 10, 25, 40, 50 and 70 MHz for ConvF assessments at 30, 64, 128, 150 and 220 MHz respectively. Above 5 GHz frequency validity can be extended to ± 110 MHz.

<sup>F</sup> At frequencies below 3 GHz, the validity of tissue parameters ( $\epsilon$  and  $\sigma$ ) can be relaxed to ± 10% if liquid compensation formula is applied to measured SAR values. At frequencies above 3 GHz, the validity of tissue parameters ( $\epsilon$  and  $\sigma$ ) is restricted to ± 5%. The uncertainty is the RSS of the ConvF uncertainty for indicated target tissue parameters.

<sup>H</sup> Alpha/Depth are determined during calibration. SPEAG warrants that the remaining deviation due to the boundary effect after compensation is always less than ± 1% for frequencies below 3 GHz and below ± 2% for frequencies between 3-6 GHz at any distance larger than half the probe tip diameter from the boundary.

EX3DV4- SN:3863

August 27, 2015

### Frequency Response of E-Field (TEM-Cell:ifi110 EXX, Waveguide: R22)

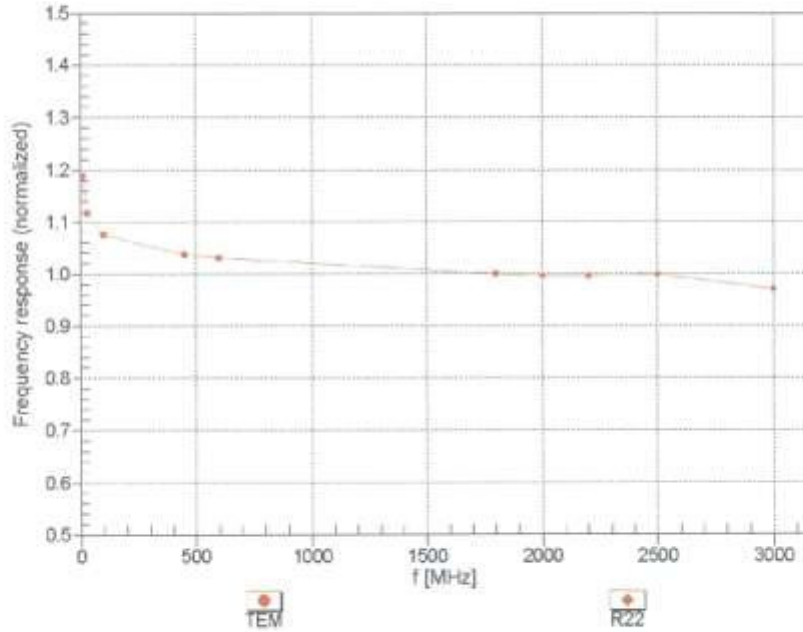

Uncertainty of Frequency Response of E-field:  $\pm 6.3\%$  (k=2)

EX3DV4- SN:3863

August 27, 2015

### Receiving Pattern ( $\phi$ ), $\theta = 0^\circ$

f=600 MHz,TEM

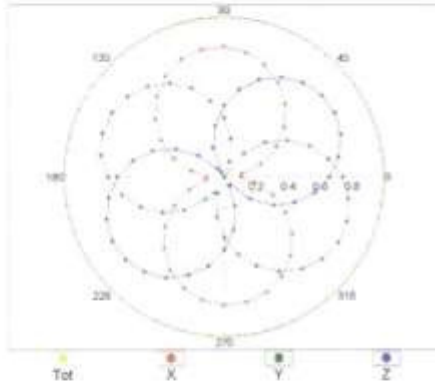

f=1800 MHz,R22

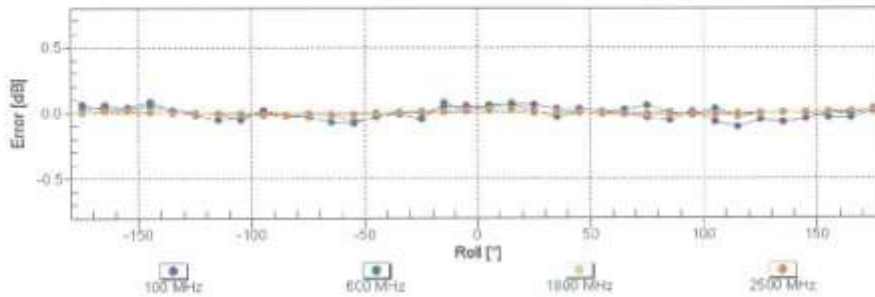
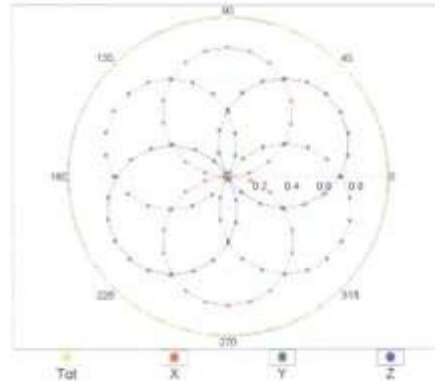

Uncertainty of Axial isotropy Assessment:  $\pm 0.5\%$  (k=2)

EX3DV4- SN:3863

August 27, 2015

**Dynamic Range f(SAR<sub>head</sub>)**  
(TEM cell , f<sub>eval</sub>= 1900 MHz)

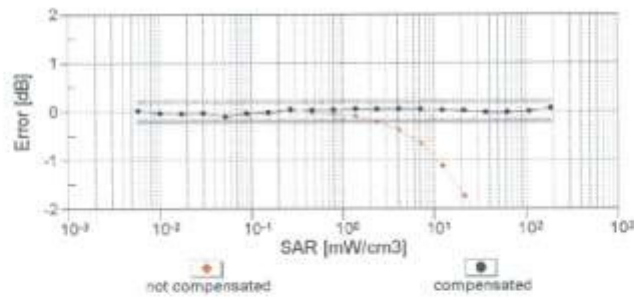
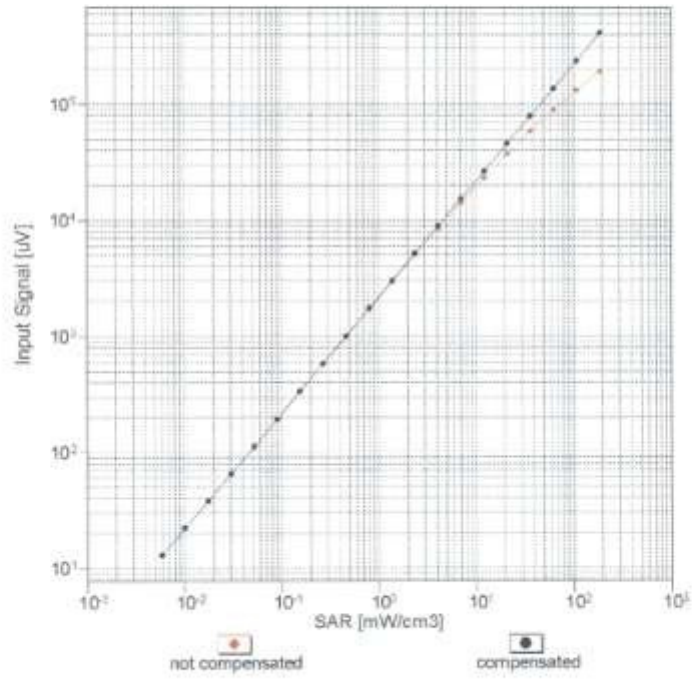

Uncertainty of Linearity Assessment: ± 0.6% (k=2)

EX3DV4-SN:3863

August 27, 2015

### Conversion Factor Assessment

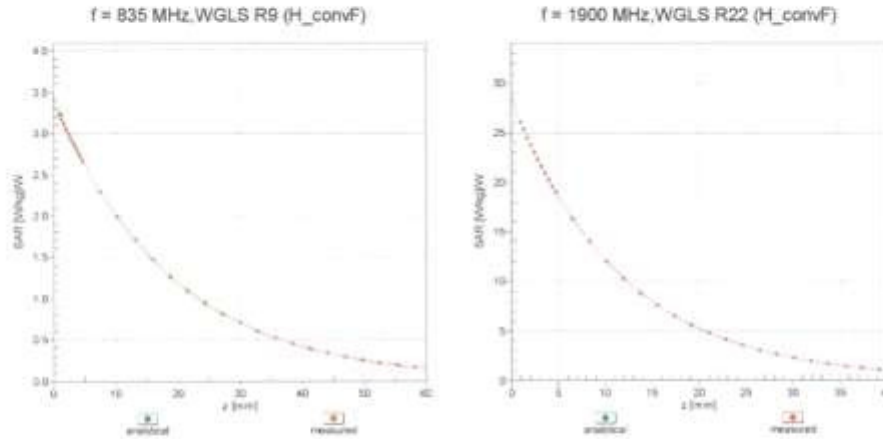

### Deviation from Isotropy in Liquid Error ( $\phi, \theta$ ), f = 900 MHz

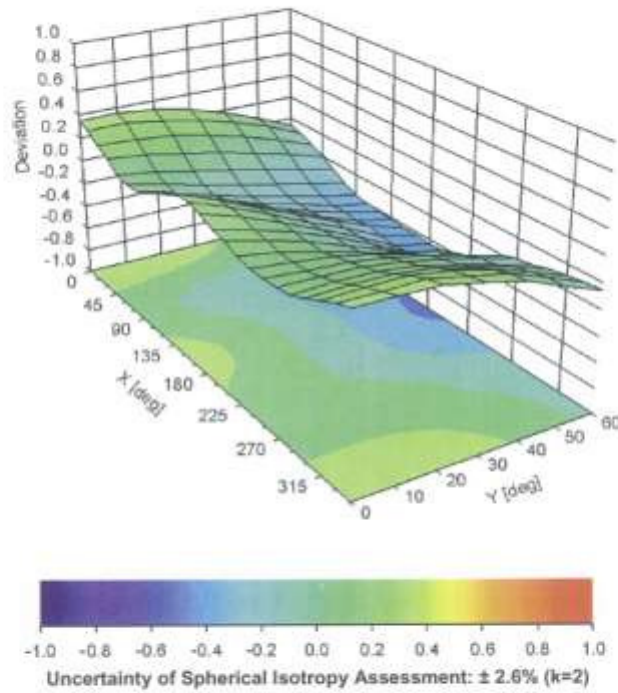

EX3DV4-SN:3863

August 27, 2015

### DASY/EASY - Parameters of Probe: EX3DV4 - SN:3863

#### Other Probe Parameters

Sensor Arrangement	Triangular
Connector Angle (°)	105.3
Mechanical Surface Detection Mode	enabled
Optical Surface Detection Mode	disabled
Probe Overall Length	337 mm
Probe Body Diameter	10 mm
Tip Length	9 mm
Tip Diameter	2.5 mm
Probe Tip to Sensor X Calibration Point	1 mm
Probe Tip to Sensor Y Calibration Point	1 mm
Probe Tip to Sensor Z Calibration Point	1 mm
Recommended Measurement Distance from Surface	1.4 mm

**Calibration Laboratory of  
Schmid & Partner  
Engineering AG**  
Zeughausstrasse 43, 8004 Zurich, Switzerland



**S** Schweizerischer Kalibrierdienst  
**C** Service suisse d'étalonnage  
**S** Servizio svizzero di taratura  
**S** Swiss Calibration Service

Accredited by the Swiss Accreditation Service (SAS)  
The Swiss Accreditation Service is one of the signatories to the EA  
Multilateral Agreement for the recognition of calibration certificates

Accreditation No.: **SCS 0108**

Client **HCT (Dymstec)**

Certificate No: **EX3-3967\_Dec15**

### CALIBRATION CERTIFICATE

Object: **EX3DV4 - SN:3967**

Calibration procedure(s): **QA CAL-01.v9, QA CAL-14.v4, QA CAL-23.v5, QA CAL-25.v6  
Calibration procedure for dosimetric E-field probes**



Calibration date: **December 16, 2015**

This calibration certificate documents the traceability to national standards, which realize the physical units of measurements (SI).  
The measurements and the uncertainties with confidence probability are given on the following pages and are part of the certificate.

All calibrations have been conducted in the closed laboratory facility, environment temperature (22 ± 3)°C and humidity < 70%.

Calibration Equipment used (M&TE critical for calibration)

Primary Standards	ID	Cal Date (Certificate No.)	Scheduled Calibration
Power meter E4419B	GB41293874	01-Apr-15 (No. 217-02128)	Mar-16
Power sensor E4412A	MY41498067	01-Apr-15 (No. 217-02128)	Mar-16
Reference 3 dB Attenuator	SN: S5054 (3c)	01-Apr-15 (No. 217-02129)	Mar-16
Reference 20 dB Attenuator	SN: S5277 (20x)	01-Apr-15 (No. 217-02132)	Mar-16
Reference 30 dB Attenuator	SN: S5129 (30b)	01-Apr-15 (No. 217-02133)	Mar-16
Reference Probe ES3DV2	SN: 3013	30-Dec-14 (No. ES3-3013_Dec14)	Dec-15
DAE4	SN: 600	14-Jan-15 (No. DAE4-600_Jan15)	Jan-16
Secondary Standards	ID	Check Date (in house)	Scheduled Check
RF generator HP 8648C	US3642U01700	4-Aug-99 (in house check Apr-13)	In house check: Apr-16
Network Analyzer HP 8753E	US37390585	18-Oct-01 (in house check Oct-15)	In house check: Oct-16

	Name	Function	Signature
Calibrated by:	Jeton Kasrati	Laboratory Technician	
Approved by:	Katja Pokovic	Technical Manager	

Issued: December 16, 2015

This calibration certificate shall not be reproduced except in full without written approval of the laboratory.

Calibration Laboratory of  
Schmid & Partner  
Engineering AG  
Zeughausstrasse 43, 8004 Zurich, Switzerland



S Schweizerischer Kalibrierdienst  
C Service suisse d'étalonnage  
S Servizio svizzero di taratura  
S Swiss Calibration Service

Accredited by the Swiss Accreditation Service (SAS)  
The Swiss Accreditation Service is one of the signatories to the EA  
Multilateral Agreement for the recognition of calibration certificates

Accreditation No.: SCS 0108

**Glossary:**

TSL	tissue simulating liquid
NORM <sub>x,y,z</sub>	sensitivity in free space
ConvF	sensitivity in TSL / NORM <sub>x,y,z</sub>
DCP	diode compression point
CF	crest factor (1/duty_cycle) of the RF signal
A, B, C, D	modulation dependent linearization parameters
Polarization $\varphi$	$\varphi$ rotation around probe axis
Polarization $\beta$	$\beta$ rotation around an axis that is in the plane normal to probe axis (at measurement center), i.e., $\beta = 0$ is normal to probe axis
Connector Angle	information used in DASY system to align probe sensor X to the robot coordinate system

**Calibration is Performed According to the Following Standards:**

- a) IEEE Std 1528-2013, "IEEE Recommended Practice for Determining the Peak Spatial-Averaged Specific Absorption Rate (SAR) in the Human Head from Wireless Communications Devices: Measurement Techniques", June 2013
- b) IEC 62209-1, "Procedure to measure the Specific Absorption Rate (SAR) for hand-held devices used in close proximity to the ear (frequency range of 300 MHz to 3 GHz)", February 2005
- c) IEC 62209-2, "Procedure to determine the Specific Absorption Rate (SAR) for wireless communication devices used in close proximity to the human body (frequency range of 30 MHz to 6 GHz)", March 2010
- d) KDB 865664, "SAR Measurement Requirements for 100 MHz to 6 GHz"

**Methods Applied and Interpretation of Parameters:**

- **NORM<sub>x,y,z</sub>**: Assessed for E-field polarization  $\beta = 0$  ( $f \leq 900$  MHz in TEM-cell;  $f > 1800$  MHz: R22 waveguide). NORM<sub>x,y,z</sub> are only intermediate values, i.e., the uncertainties of NORM<sub>x,y,z</sub> does not affect the E<sup>2</sup>-field uncertainty inside TSL (see below ConvF).
- **NORM(f)<sub>x,y,z</sub> = NORM<sub>x,y,z</sub> \* frequency\_response** (see Frequency Response Chart). This linearization is implemented in DASY4 software versions later than 4.2. The uncertainty of the frequency response is included in the stated uncertainty of ConvF.
- **DCP<sub>x,y,z</sub>**: DCP are numerical linearization parameters assessed based on the data of power sweep with CW signal (no uncertainty required). DCP does not depend on frequency nor media.
- **PAR**: PAR is the Peak to Average Ratio that is not calibrated but determined based on the signal characteristics
- **A<sub>x,y,z</sub>; B<sub>x,y,z</sub>; C<sub>x,y,z</sub>; D<sub>x,y,z</sub>; VR<sub>x,y,z</sub>**: A, B, C, D are numerical linearization parameters assessed based on the data of power sweep for specific modulation signal. The parameters do not depend on frequency nor media. VR is the maximum calibration range expressed in RMS voltage across the diode.
- **ConvF and Boundary Effect Parameters**: Assessed in flat phantom using E-field (or Temperature Transfer Standard for  $f \leq 800$  MHz) and inside waveguide using analytical field distributions based on power measurements for  $f > 800$  MHz. The same setups are used for assessment of the parameters applied for boundary compensation (alpha, depth) of which typical uncertainty values are given. These parameters are used in DASY4 software to improve probe accuracy close to the boundary. The sensitivity in TSL corresponds to NORM<sub>x,y,z</sub> \* ConvF whereby the uncertainty corresponds to that given for ConvF. A frequency dependent ConvF is used in DASY version 4.4 and higher which allows extending the validity from  $\pm 50$  MHz to  $\pm 100$  MHz.
- **Spherical isotropy (3D deviation from isotropy)**: in a field of low gradients realized using a flat phantom exposed by a patch antenna.
- **Sensor Offset**: The sensor offset corresponds to the offset of virtual measurement center from the probe tip (on probe axis). No tolerance required.
- **Connector Angle**: The angle is assessed using the information gained by determining the NORM<sub>x</sub> (no uncertainty required).

EX3DV4 – SN:3967

December 16, 2015

# Probe EX3DV4

## SN:3967

Manufactured: September 30, 2013  
Calibrated: December 16, 2015

Calibrated for DASY/EASY Systems  
(Note: non-compatible with DASY2 system!)

EX3DV4- SN:3967

December 16, 2015

## DASY/EASY - Parameters of Probe: EX3DV4 - SN:3967

### Basic Calibration Parameters

	Sensor X	Sensor Y	Sensor Z	Unc (k=2)
Norm ( $\mu\text{V}/(\text{V}/\text{m})^2$ ) <sup>A</sup>	0.54	0.38	0.48	$\pm 10.1\%$
DCP (mV) <sup>B</sup>	101.3	97.8	101.0	

### Modulation Calibration Parameters

UID	Communication System Name		A dB	B dB $\sqrt{\mu\text{V}}$	C	D dB	VR mV	Unc <sup>C</sup> (k=2)
0	CW	X	0.0	0.0	1.0	0.00	145.0	$\pm 3.5\%$
		Y	0.0	0.0	1.0		143.7	
		Z	0.0	0.0	1.0		138.2	

The reported uncertainty of measurement is stated as the standard uncertainty of measurement multiplied by the coverage factor k=2, which for a normal distribution corresponds to a coverage probability of approximately 95%.

<sup>A</sup> The uncertainties of Norm X,Y,Z do not affect the E<sup>2</sup>-field uncertainty inside TSL (see Pages 5 and 6).

<sup>B</sup> Numerical linearization parameter; uncertainty not required.

<sup>C</sup> Uncertainty is determined using the max. deviation from linear response applying rectangular distribution and is expressed for the square of the field value.

EX3DV4-- SN:3967

December 16, 2015

## DASY/EASY - Parameters of Probe: EX3DV4 - SN:3967

### Calibration Parameter Determined in Head Tissue Simulating Media

f (MHz) <sup>c</sup>	Relative Permittivity <sup>f</sup>	Conductivity (S/m) <sup>f</sup>	ConvF X	ConvF Y	ConvF Z	Alpha <sup>g</sup>	Depth <sup>g</sup> (mm)	Unc (k=2)
750	41.9	0.89	10.27	10.27	10.27	0.21	1.39	± 12.0 %
835	41.5	0.90	9.87	9.87	9.87	0.20	1.38	± 12.0 %
900	41.5	0.97	9.70	9.70	9.70	0.25	1.15	± 12.0 %
1450	40.5	1.20	8.19	8.19	8.19	0.29	0.92	± 12.0 %
1750	40.1	1.37	8.39	8.39	8.39	0.25	0.88	± 12.0 %
1900	40.0	1.40	8.11	8.11	8.11	0.39	0.80	± 12.0 %
1950	40.0	1.40	7.90	7.90	7.90	0.38	0.86	± 12.0 %
2300	39.5	1.67	7.73	7.73	7.73	0.37	0.84	± 12.0 %
2450	39.2	1.80	7.42	7.42	7.42	0.40	0.80	± 12.0 %
2600	39.0	1.96	7.17	7.17	7.17	0.41	0.83	± 12.0 %
3500	37.9	2.91	7.69	7.69	7.69	0.94	0.63	± 13.1 %
5200	36.0	4.66	5.37	5.37	5.37	0.35	1.80	± 13.1 %
5300	35.9	4.76	5.04	5.04	5.04	0.40	1.80	± 13.1 %
5500	35.6	4.96	4.87	4.87	4.87	0.45	1.80	± 13.1 %
5600	35.5	5.07	4.65	4.65	4.65	0.50	1.80	± 13.1 %
5800	35.3	5.27	4.69	4.69	4.69	0.50	1.80	± 13.1 %

<sup>c</sup> Frequency validity above 300 MHz of ± 100 MHz only applies for DASY v4.4 and higher (see Page 2), else it is restricted to ± 50 MHz. The uncertainty is the RSS of the ConvF uncertainty at calibration frequency and the uncertainty for the indicated frequency band. Frequency validity below 300 MHz is ± 10, 25, 40, 50 and 70 MHz for ConvF assessments at 30, 64, 128, 150 and 220 MHz respectively. Above 5 GHz frequency validity can be extended to ± 110 MHz.

<sup>f</sup> At frequencies below 3 GHz, the validity of tissue parameters ( $\epsilon$  and  $\sigma$ ) can be relaxed to ± 10% if liquid compensation formula is applied to measured SAR values. At frequencies above 3 GHz, the validity of tissue parameters ( $\epsilon$  and  $\sigma$ ) is restricted to ± 5%. The uncertainty is the RSS of the ConvF uncertainty for indicated target tissue parameters.

<sup>g</sup> Alpha/Depth are determined during calibration. SPEAG warrants that the remaining deviation due to the boundary effect after compensation is always less than ± 1% for frequencies below 3 GHz and below ± 2% for frequencies between 3-6 GHz at any distance larger than half the probe tip diameter from the boundary.

EX3DV4- SN:3967

December 16, 2015

## DASY/EASY - Parameters of Probe: EX3DV4 - SN:3967

### Calibration Parameter Determined in Body Tissue Simulating Media

f (MHz) <sup>c</sup>	Relative Permittivity <sup>e</sup>	Conductivity (S/m) <sup>f</sup>	ConvF X	ConvF Y	ConvF Z	Alpha <sup>g</sup>	Depth <sup>h</sup> (mm)	Unc (k=2)
750	55.5	0.96	9.92	9.92	9.92	0.22	1.41	± 12.0 %
835	55.2	0.97	9.76	9.76	9.76	0.24	1.28	± 12.0 %
1750	53.4	1.49	8.04	8.04	8.04	0.40	0.85	± 12.0 %
1900	53.3	1.52	7.95	7.95	7.95	0.35	0.92	± 12.0 %
2450	52.7	1.95	7.31	7.31	7.31	0.40	0.86	± 12.0 %
2600	52.5	2.16	7.19	7.19	7.19	0.25	1.05	± 12.0 %
3500	51.3	3.31	6.86	6.86	6.86	0.36	1.14	± 13.1 %
5200	49.0	5.30	4.32	4.32	4.32	0.55	1.90	± 13.1 %
5300	48.9	5.42	4.23	4.23	4.23	0.55	1.90	± 13.1 %
5500	48.6	5.65	3.80	3.80	3.80	0.60	1.90	± 13.1 %
5600	48.5	5.77	3.70	3.70	3.70	0.60	1.90	± 13.1 %
5800	48.2	6.00	3.82	3.82	3.82	0.60	1.90	± 13.1 %

<sup>c</sup> Frequency validity above 300 MHz of ± 100 MHz only applies for DASY v4.4 and higher (see Page 2), else it is restricted to ± 50 MHz. The uncertainty is the RSS of the ConvF uncertainty at calibration frequency and the uncertainty for the indicated frequency band. Frequency validity below 300 MHz is ± 10, 25, 40, 50 and 70 MHz for ConvF assessments at 30, 64, 128, 150 and 220 MHz respectively. Above 5 GHz frequency validity can be extended to ± 110 MHz.

<sup>e</sup> At frequencies below 3 GHz, the validity of tissue parameters ( $\epsilon$  and  $\sigma$ ) can be relaxed to ± 10% if liquid compensation formula is applied to measured SAR values. At frequencies above 3 GHz, the validity of tissue parameters ( $\epsilon$  and  $\sigma$ ) is restricted to ± 5%. The uncertainty is the RSS of the ConvF uncertainty for indicated target tissue parameters.

<sup>h</sup> Alpha/Depth are determined during calibration. SPEAG warrants that the remaining deviation due to the boundary effect after compensation is always less than ± 1% for frequencies below 3 GHz and below ± 2% for frequencies between 3-6 GHz at any distance larger than half the probe tip diameter from the boundary.

EX3DV4-SN:3967

December 16, 2015

### Frequency Response of E-Field (TEM-Cell:ifi110 EXX, Waveguide: R22)

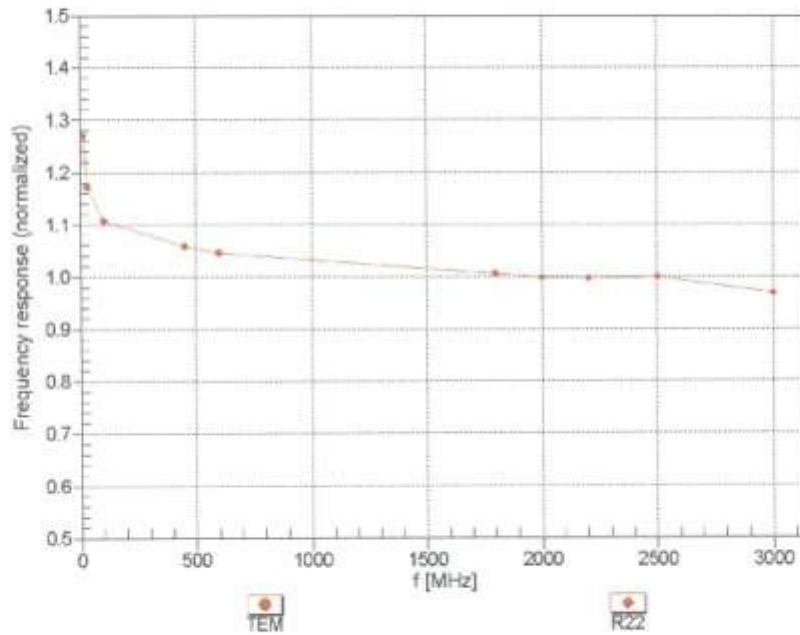

Uncertainty of Frequency Response of E-field:  $\pm 6.3\%$  (k=2)

EX3DV4--SN:3967

December 16, 2015

**Receiving Pattern ( $\phi$ ),  $\theta = 0^\circ$**

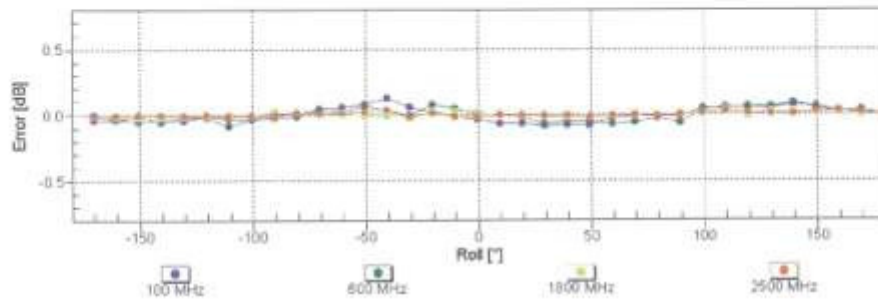
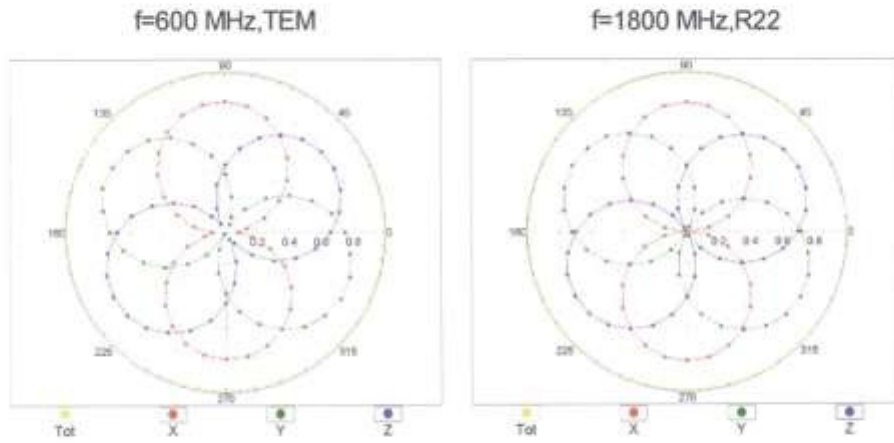

Uncertainty of Axial Isotropy Assessment:  $\pm 0.5\%$  (k=2)

EX3DV4- SN:3967

December 16, 2015

**Dynamic Range f(SAR<sub>head</sub>)**  
(TEM cell , f<sub>eval</sub>= 1900 MHz)

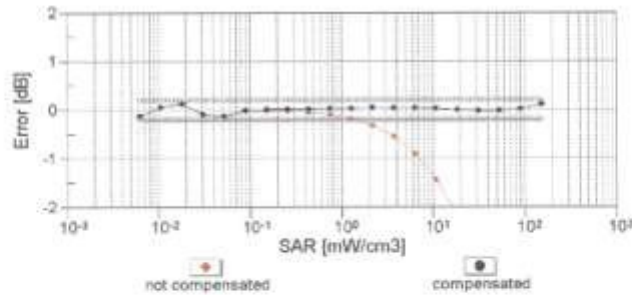
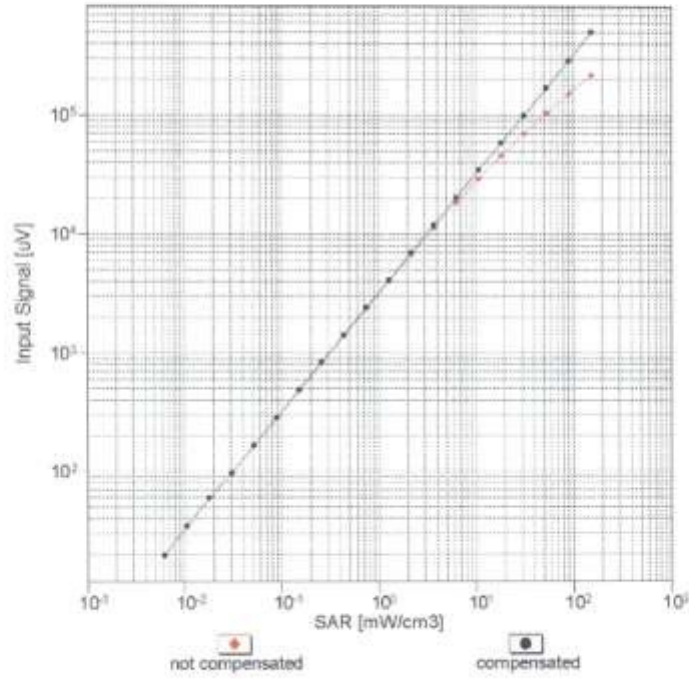

Uncertainty of Linearity Assessment: ± 0.6% (k=2)

EX3DVA-SN:3967

December 16, 2015

### Conversion Factor Assessment

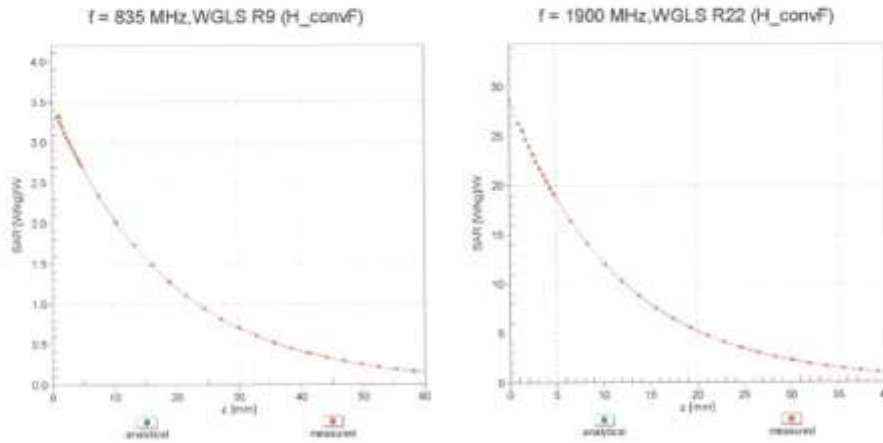

### Deviation from Isotropy in Liquid Error ( $\phi, \theta$ ), f = 900 MHz

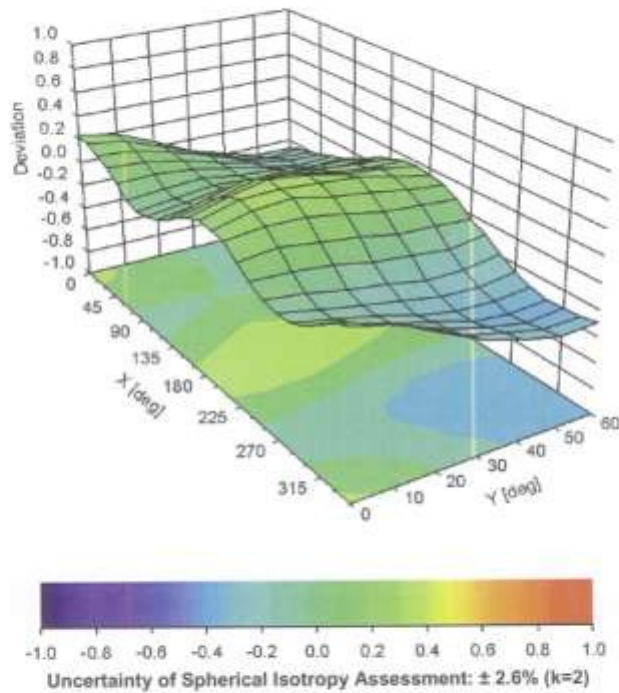

EX3DV4- SN:3967

December 16, 2015

## DASY/EASY - Parameters of Probe: EX3DV4 - SN:3967

### Other Probe Parameters

Sensor Arrangement	Triangular
Connector Angle (°)	-20.6
Mechanical Surface Detection Mode	enabled
Optical Surface Detection Mode	disabled
Probe Overall Length	337 mm
Probe Body Diameter	10 mm
Tip Length	9 mm
Tip Diameter	2.5 mm
Probe Tip to Sensor X Calibration Point	1 mm
Probe Tip to Sensor Y Calibration Point	1 mm
Probe Tip to Sensor Z Calibration Point	1 mm
Recommended Measurement Distance from Surface	1.4 mm

## Attachment 4. – Dipole Calibration Data

Calibration Laboratory of  
Schmid & Partner  
Engineering AG  
Zeughausstrasse 43, 8004 Zurich, Switzerland



S Schweizerischer Kalibrierdienst  
C Service suisse d'étalonnage  
S Servizio svizzero di taratura  
S Swiss Calibration Service

Accredited by the Swiss Accreditation Service (SAS)  
The Swiss Accreditation Service is one of the signatories to the EA  
Multilateral Agreement for the recognition of calibration certificates

Accreditation No.: SCS 0108

Client **HCT (Dymstec)**

Certificate No: **D835V2-4d165\_Nov15**

CALIBRATION CERTIFICATE																																															
Object	D835V2 - SN: 4d165																																														
Calibration procedure(s)	QA CAL-05.v9 Calibration procedure for dipole validation kits above 700 MHz																																														
Calibration date:	November 24, 2015																																														
<p>This calibration certificate documents the traceability to national standards, which realize the physical units of measurements (SI). The measurements and the uncertainties with confidence probability are given on the following pages and are part of the certificate.</p> <p>All calibrations have been conducted in the closed laboratory facility: environment temperature (22 ± 3)°C and humidity &lt; 70%.</p> <p>Calibration Equipment used (M&amp;TE critical for calibration)</p> <table border="1"> <thead> <tr> <th>Primary Standards</th> <th>ID #</th> <th>Cal Date (Certificate No.)</th> <th>Scheduled Calibration</th> </tr> </thead> <tbody> <tr> <td>Power meter EPM-442A</td> <td>GB37480704</td> <td>07-Oct-15 (No. 217-02222)</td> <td>Oct-16</td> </tr> <tr> <td>Power sensor HP 8481A</td> <td>US37292783</td> <td>07-Oct-15 (No. 217-02222)</td> <td>Oct-16</td> </tr> <tr> <td>Power sensor HP 8481A</td> <td>MY41092317</td> <td>07-Oct-15 (No. 217-02223)</td> <td>Oct-16</td> </tr> <tr> <td>Reference 20 dB Attenuator</td> <td>SN: 5058 (20k)</td> <td>01-Apr-15 (No. 217-02131)</td> <td>Mar-16</td> </tr> <tr> <td>Type-N mismatch combination</td> <td>SN: 5047.2 / 08327</td> <td>01-Apr-15 (No. 217-02134)</td> <td>Mar-16</td> </tr> <tr> <td>Reference Probe EX3DV4</td> <td>SN: 7349</td> <td>30-Dec-14 (No. EX3-7349_Dec14)</td> <td>Dec-15</td> </tr> <tr> <td>DAE4</td> <td>SN: 601</td> <td>17-Aug-15 (No. DAE4-601_Aug15)</td> <td>Aug-16</td> </tr> </tbody> </table> <table border="1"> <thead> <tr> <th>Secondary Standards</th> <th>ID #</th> <th>Check Date (in house)</th> <th>Scheduled Check</th> </tr> </thead> <tbody> <tr> <td>RF generator R&amp;S SMT-06</td> <td>100972</td> <td>15-Jun-15 (in house check Jun-15)</td> <td>In house check: Jun-16</td> </tr> <tr> <td>Network Analyzer HP 8753E</td> <td>US37390585 S4206</td> <td>18-Oct-01 (in house check Oct-15)</td> <td>In house check: Oct-16</td> </tr> </tbody> </table>				Primary Standards	ID #	Cal Date (Certificate No.)	Scheduled Calibration	Power meter EPM-442A	GB37480704	07-Oct-15 (No. 217-02222)	Oct-16	Power sensor HP 8481A	US37292783	07-Oct-15 (No. 217-02222)	Oct-16	Power sensor HP 8481A	MY41092317	07-Oct-15 (No. 217-02223)	Oct-16	Reference 20 dB Attenuator	SN: 5058 (20k)	01-Apr-15 (No. 217-02131)	Mar-16	Type-N mismatch combination	SN: 5047.2 / 08327	01-Apr-15 (No. 217-02134)	Mar-16	Reference Probe EX3DV4	SN: 7349	30-Dec-14 (No. EX3-7349_Dec14)	Dec-15	DAE4	SN: 601	17-Aug-15 (No. DAE4-601_Aug15)	Aug-16	Secondary Standards	ID #	Check Date (in house)	Scheduled Check	RF generator R&S SMT-06	100972	15-Jun-15 (in house check Jun-15)	In house check: Jun-16	Network Analyzer HP 8753E	US37390585 S4206	18-Oct-01 (in house check Oct-15)	In house check: Oct-16
Primary Standards	ID #	Cal Date (Certificate No.)	Scheduled Calibration																																												
Power meter EPM-442A	GB37480704	07-Oct-15 (No. 217-02222)	Oct-16																																												
Power sensor HP 8481A	US37292783	07-Oct-15 (No. 217-02222)	Oct-16																																												
Power sensor HP 8481A	MY41092317	07-Oct-15 (No. 217-02223)	Oct-16																																												
Reference 20 dB Attenuator	SN: 5058 (20k)	01-Apr-15 (No. 217-02131)	Mar-16																																												
Type-N mismatch combination	SN: 5047.2 / 08327	01-Apr-15 (No. 217-02134)	Mar-16																																												
Reference Probe EX3DV4	SN: 7349	30-Dec-14 (No. EX3-7349_Dec14)	Dec-15																																												
DAE4	SN: 601	17-Aug-15 (No. DAE4-601_Aug15)	Aug-16																																												
Secondary Standards	ID #	Check Date (in house)	Scheduled Check																																												
RF generator R&S SMT-06	100972	15-Jun-15 (in house check Jun-15)	In house check: Jun-16																																												
Network Analyzer HP 8753E	US37390585 S4206	18-Oct-01 (in house check Oct-15)	In house check: Oct-16																																												
Calibrated by:	Name Michael Weber	Function Laboratory Technician	Signature 																																												
Approved by:	Name Katja Pokovic	Function Technical Manager	Signature 																																												
			Issued: November 24, 2015																																												
This calibration certificate shall not be reproduced except in full without written approval of the laboratory.																																															

**Calibration Laboratory of  
Schmid & Partner  
Engineering AG**  
Zeughausstrasse 43, 8004 Zurich, Switzerland



**S** Schweizerischer Kalibrierdienst  
**C** Service suisse d'étalonnage  
**S** Servizio svizzero di taratura  
**S** Swiss Calibration Service

Accredited by the Swiss Accreditation Service (SAS)  
The Swiss Accreditation Service is one of the signatories to the EA  
Multilateral Agreement for the recognition of calibration certificates

Accreditation No.: **SCS 0108**

**Glossary:**

TSL tissue simulating liquid  
ConvF sensitivity in TSL / NORM x,y,z  
N/A not applicable or not measured

**Calibration is Performed According to the Following Standards:**

- a) IEEE Std 1528-2013, "IEEE Recommended Practice for Determining the Peak Spatial-Averaged Specific Absorption Rate (SAR) in the Human Head from Wireless Communications Devices: Measurement Techniques", June 2013
- b) IEC 62209-1, "Procedure to measure the Specific Absorption Rate (SAR) for hand-held devices used in close proximity to the ear (frequency range of 300 MHz to 3 GHz)", February 2005
- c) IEC 62209-2, "Procedure to determine the Specific Absorption Rate (SAR) for wireless communication devices used in close proximity to the human body (frequency range of 30 MHz to 6 GHz)", March 2010
- d) KDB 865664, "SAR Measurement Requirements for 100 MHz to 6 GHz"

**Additional Documentation:**

- e) DASY4/5 System Handbook

**Methods Applied and Interpretation of Parameters:**

- *Measurement Conditions:* Further details are available from the Validation Report at the end of the certificate. All figures stated in the certificate are valid at the frequency indicated.
- *Antenna Parameters with TSL:* The dipole is mounted with the spacer to position its feed point exactly below the center marking of the flat phantom section, with the arms oriented parallel to the body axis.
- *Feed Point Impedance and Return Loss:* These parameters are measured with the dipole positioned under the liquid filled phantom. The impedance stated is transformed from the measurement at the SMA connector to the feed point. The Return Loss ensures low reflected power. No uncertainty required.
- *Electrical Delay:* One-way delay between the SMA connector and the antenna feed point. No uncertainty required.
- *SAR measured:* SAR measured at the stated antenna input power.
- *SAR normalized:* SAR as measured, normalized to an input power of 1 W at the antenna connector.
- *SAR for nominal TSL parameters:* The measured TSL parameters are used to calculate the nominal SAR result.

The reported uncertainty of measurement is stated as the standard uncertainty of measurement multiplied by the coverage factor  $k=2$ , which for a normal distribution corresponds to a coverage probability of approximately 95%.

**Measurement Conditions**

DASY system configuration, as far as not given on page 1.

DASY Version	DASY5	V52.8.8
Extrapolation	Advanced Extrapolation	
Phantom	Modular Flat Phantom	
Distance Dipole Center - TSL	15 mm	with Spacer
Zoom Scan Resolution	dx, dy, dz = 5 mm	
Frequency	835 MHz ± 1 MHz	

**Head TSL parameters**

The following parameters and calculations were applied.

	Temperature	Permittivity	Conductivity
Nominal Head TSL parameters	22.0 °C	41.5	0.90 mho/m
Measured Head TSL parameters	(22.0 ± 0.2) °C	42.6 ± 6 %	0.92 mho/m ± 6 %
Head TSL temperature change during test	< 0.5 °C	----	----

**SAR result with Head TSL**

SAR averaged over 1 cm <sup>3</sup> (1 g) of Head TSL	Condition	
SAR measured	250 mW input power	2.29 W/kg
SAR for nominal Head TSL parameters	normalized to 1W	9.06 W/kg ± 17.0 % (k=2)

SAR averaged over 10 cm <sup>3</sup> (10 g) of Head TSL	condition	
SAR measured	250 mW input power	1.49 W/kg
SAR for nominal Head TSL parameters	normalized to 1W	5.90 W/kg ± 16.5 % (k=2)

**Body TSL parameters**

The following parameters and calculations were applied.

	Temperature	Permittivity	Conductivity
Nominal Body TSL parameters	22.0 °C	55.2	0.97 mho/m
Measured Body TSL parameters	(22.0 ± 0.2) °C	55.6 ± 6 %	0.99 mho/m ± 6 %
Body TSL temperature change during test	< 0.5 °C	----	----

**SAR result with Body TSL**

SAR averaged over 1 cm <sup>3</sup> (1 g) of Body TSL	Condition	
SAR measured	250 mW input power	2.40 W/kg
SAR for nominal Body TSL parameters	normalized to 1W	9.47 W/kg ± 17.0 % (k=2)

SAR averaged over 10 cm <sup>3</sup> (10 g) of Body TSL	condition	
SAR measured	250 mW input power	1.58 W/kg
SAR for nominal Body TSL parameters	normalized to 1W	6.25 W/kg ± 16.5 % (k=2)

**Appendix (Additional assessments outside the scope of SCS 0108)****Antenna Parameters with Head TSL**

Impedance, transformed to feed point	52.1 $\Omega$ - 4.7 $j\Omega$
Return Loss	- 26.0 dB

**Antenna Parameters with Body TSL**

Impedance, transformed to feed point	47.8 $\Omega$ - 6.8 $j\Omega$
Return Loss	- 22.7 dB

**General Antenna Parameters and Design**

Electrical Delay (one direction)	1.440 ns
----------------------------------	----------

After long term use with 100W radiated power, only a slight warming of the dipole near the feedpoint can be measured.

The dipole is made of standard semirigid coaxial cable. The center conductor of the feeding line is directly connected to the second arm of the dipole. The antenna is therefore short-circuited for DC-signals. On some of the dipoles, small end caps are added to the dipole arms in order to improve matching when loaded according to the position as explained in the "Measurement Conditions" paragraph. The SAR data are not affected by this change. The overall dipole length is still according to the Standard.

No excessive force must be applied to the dipole arms, because they might bend or the soldered connections near the feedpoint may be damaged.

**Additional EUT Data**

Manufactured by	SPEAG
Manufactured on	December 28, 2012

**DASY5 Validation Report for Head TSL**

Date: 24.11.2015

Test Laboratory: SPEAG, Zurich, Switzerland

**DUT: Dipole 835 MHz; Type: D835V2; Serial: D835V2 - SN: 4d165**

Communication System: UID 0 - CW; Frequency: 835 MHz

Medium parameters used:  $f = 835$  MHz;  $\sigma = 0.92$  S/m;  $\epsilon_r = 42.6$ ;  $\rho = 1000$  kg/m<sup>3</sup>

Phantom section: Flat Section

Measurement Standard: DASY5 (IEEE/IEC/ANSI C63.19-2011)

DASY52 Configuration:

- Probe: EX3DV4 - SN7349; ConvF(9.77, 9.77, 9.77); Calibrated: 30.12.2014;
- Sensor-Surface: 1.4mm (Mechanical Surface Detection)
- Electronics: DAE4 Sn601; Calibrated: 17.08.2015
- Phantom: Flat Phantom 4.9L; Type: QD000P49AA; Serial: 1001
- DASY52 52.8.8(1222); SEMCAD X 14.6.10(7331)

**Dipole Calibration for Head Tissue/Pin=250 mW, d=15mm/Zoom Scan (7x7x7)/Cube 0:**

Measurement grid: dx=5mm, dy=5mm, dz=5mm

Reference Value = 60.39 V/m; Power Drift = 0.02 dB

Peak SAR (extrapolated) = 3.40 W/kg

**SAR(1 g) = 2.29 W/kg; SAR(10 g) = 1.49 W/kg**

Maximum value of SAR (measured) = 3.03 W/kg

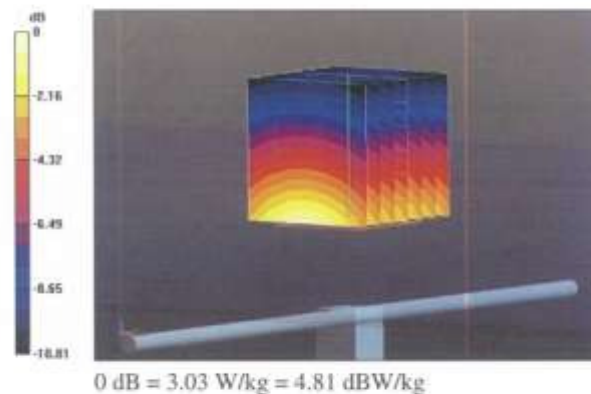

Impedance Measurement Plot for Head TSL

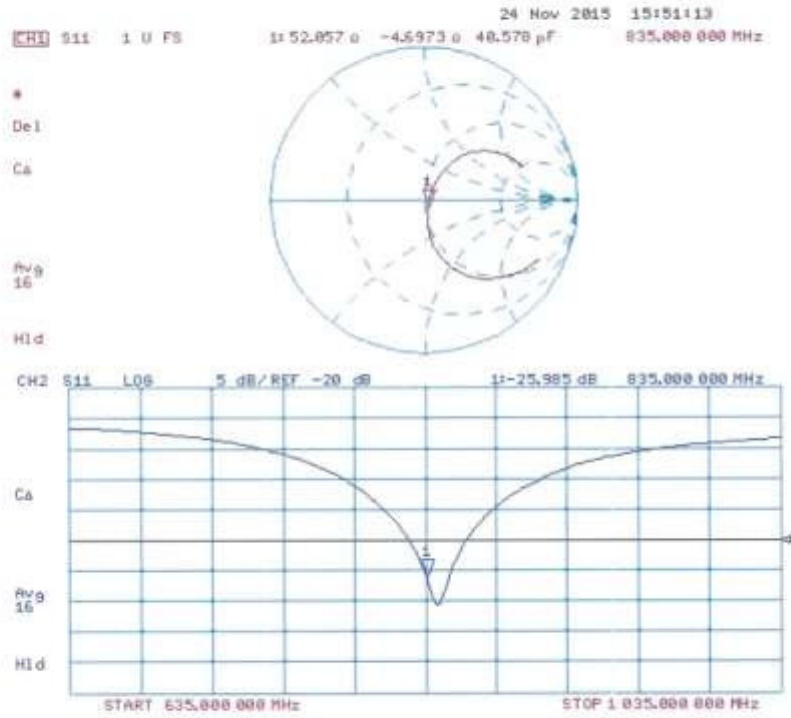

**DASY5 Validation Report for Body TSL**

Date: 24.11.2015

Test Laboratory: SPEAG, Zurich, Switzerland

**DUT: Dipole 835 MHz; Type: D835V2; Serial: D835V2 - SN: 4d165**

Communication System: UID 0 - CW; Frequency: 835 MHz  
Medium parameters used:  $f = 835$  MHz;  $\sigma = 0.99$  S/m;  $\epsilon_r = 55.6$ ;  $\rho = 1000$  kg/m<sup>3</sup>  
Phantom section: Flat Section  
Measurement Standard: DASY5 (IEEE/IEC/ANSI C63.19-2011)

DASY52 Configuration:

- Probe: EX3DV4 - SN7349; ConvF(9.72, 9.72, 9.72); Calibrated: 30.12.2014;
- Sensor-Surface: 1.4mm (Mechanical Surface Detection)
- Electronics: DAE4 Sn601; Calibrated: 17.08.2015
- Phantom: Flat Phantom 4.9L; Type: QD000P49AA; Serial: 1001
- DASY52 52.8.8(1222); SEMCAD X 14.6.10(7331)

**Dipole Calibration for Body Tissue/Pin=250 mW, d=15mm/Zoom Scan (7x7x7)/Cube 0:**

Measurement grid: dx=5mm, dy=5mm, dz=5mm  
Reference Value = 61.95 V/m; Power Drift = -0.02 dB  
Peak SAR (extrapolated) = 3.54 W/kg  
SAR(1 g) = 2.4 W/kg; SAR(10 g) = 1.58 W/kg  
Maximum value of SAR (measured) = 3.17 W/kg

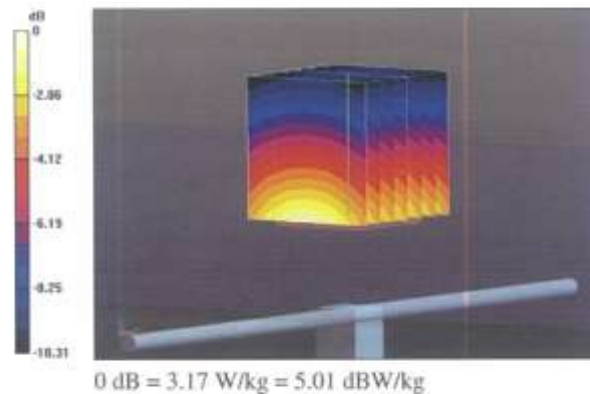

Impedance Measurement Plot for Body TSL

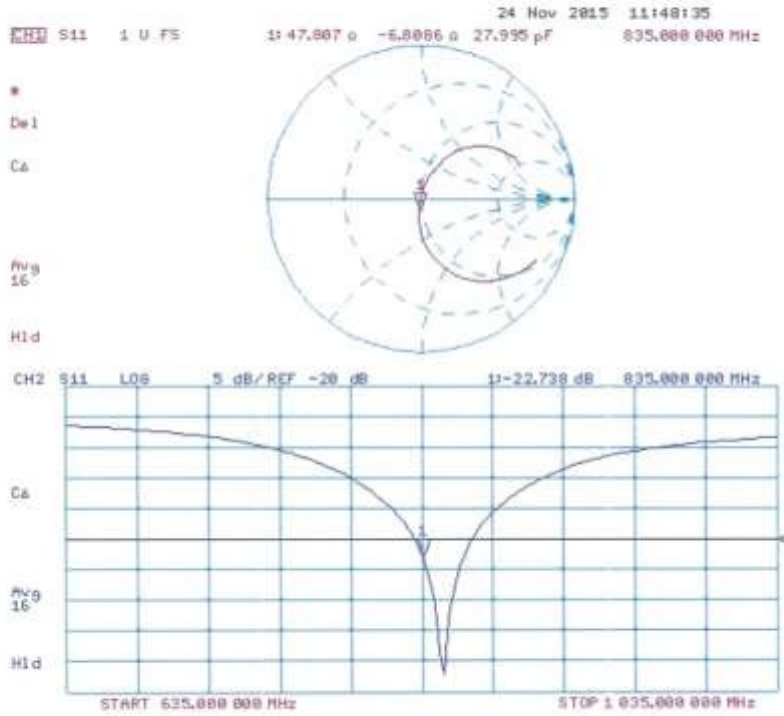

**Calibration Laboratory of  
Schmid & Partner  
Engineering AG**  
Zeughausstrasse 43, 8004 Zurich, Switzerland



**S** Schweizerischer Kalibrierdienst  
**S** Service suisse d'étalonnage  
**C** Servizio svizzero di taratura  
**S** Swiss Calibration Service

Accredited by the Swiss Accreditation Service (SAS)  
The Swiss Accreditation Service is one of the signatories to the EA  
Multilateral Agreement for the recognition of calibration certificates

Accreditation No.: **SCS 0108**

Client **HCT (Dymstec)**

Certificate No: **D1900V2-5d032\_May15**

**CALIBRATION CERTIFICATE**

Object: **D1900V2 - SN: 5d032**

Calibration procedure(s): **QA CAL-05.v9  
Calibration procedure for dipole validation kits above 700 MHz**

Calibration date: **May 20, 2015**

This calibration certificate documents the traceability to national standards, which realize the physical units of measurements (SI).  
The measurements and the uncertainties with confidence probability are given on the following pages and are part of the certificate.

All calibrations have been conducted in the closed laboratory facility: environment temperature (22 ± 3)°C and humidity < 70%.

Calibration Equipment used (M&TE critical for calibration)

Primary Standards	ID #	Cal Date (Certificate No.)	Scheduled Calibration
Power meter EPM-442A	GB37480704	07-Oct-14 (No. 217-02020)	Oct-15
Power sensor HP 8481A	US37292783	07-Oct-14 (No. 217-02020)	Oct-15
Power sensor HP 8481A	MY41092317	07-Oct-14 (No. 217-02021)	Oct-15
Reference 20 dB Attenuator	SN: 5058 (20k)	01-Apr-15 (No. 217-02131)	Mar-16
Type-N mismatch combination	SN: 5047.2 / 06327	01-Apr-15 (No. 217-02134)	Mar-16
Reference Probe ES3DV3	SN: 3205	30-Dec-14 (No. ES3-3205_Dec14)	Dec-15
DAE4	SN: 601	18-Aug-14 (No. DAE4-601_Aug14)	Aug-15
Secondary Standards	ID #	Check Date (in house)	Scheduled Check
RF generator R&S SMT-06	100005	04-Aug-09 (in house check Oct-13)	In house check: Oct-15
Network Analyzer HP 8753E	US37390595 S4206	18-Oct-01 (in house check Oct-14)	In house check: Oct-15

	Name	Function	Signature
Calibrated by:	Leif Klyzner	Laboratory Technician	
Approved by:	Katja Pokovic	Technical Manager	

Issued: May 20, 2015

This calibration certificate shall not be reproduced except in full without written approval of the laboratory.

**Calibration Laboratory of  
Schmid & Partner  
Engineering AG**  
Zeughausstrasse 43, 8004 Zurich, Switzerland



**S** Schweizerischer Kalibrierdienst  
**S** Service suisse d'étalonnage  
**C** Servizio svizzero di taratura  
**S** Swiss Calibration Service

Accredited by the Swiss Accreditation Service (SAS)  
The Swiss Accreditation Service is one of the signatories to the EA  
Multilateral Agreement for the recognition of calibration certificates

Accreditation No.: **SCS 0108**

**Glossary:**

TSL tissue simulating liquid  
ConvF sensitivity in TSL / NORM x,y,z  
N/A not applicable or not measured

**Calibration is Performed According to the Following Standards:**

- a) IEEE Std 1528-2013, "IEEE Recommended Practice for Determining the Peak Spatial-Averaged Specific Absorption Rate (SAR) in the Human Head from Wireless Communications Devices: Measurement Techniques", June 2013
- b) IEC 62209-1, "Procedure to measure the Specific Absorption Rate (SAR) for hand-held devices used in close proximity to the ear (frequency range of 300 MHz to 3 GHz)", February 2005
- c) KDB 865664, "SAR Measurement Requirements for 100 MHz to 6 GHz"

**Additional Documentation:**

- d) DASY4/5 System Handbook

**Methods Applied and Interpretation of Parameters:**

- *Measurement Conditions:* Further details are available from the Validation Report at the end of the certificate. All figures stated in the certificate are valid at the frequency indicated.
- *Antenna Parameters with TSL:* The dipole is mounted with the spacer to position its feed point exactly below the center marking of the flat phantom section, with the arms oriented parallel to the body axis.
- *Feed Point Impedance and Return Loss:* These parameters are measured with the dipole positioned under the liquid filled phantom. The impedance stated is transformed from the measurement at the SMA connector to the feed point. The Return Loss ensures low reflected power. No uncertainty required.
- *Electrical Delay:* One-way delay between the SMA connector and the antenna feed point. No uncertainty required.
- *SAR measured:* SAR measured at the stated antenna input power.
- *SAR normalized:* SAR as measured, normalized to an input power of 1 W at the antenna connector.
- *SAR for nominal TSL parameters:* The measured TSL parameters are used to calculate the nominal SAR result.

The reported uncertainty of measurement is stated as the standard uncertainty of measurement multiplied by the coverage factor  $k=2$ , which for a normal distribution corresponds to a coverage probability of approximately 95%.

**Measurement Conditions**

DASY system configuration, as far as not given on page 1.

DASY Version	DASY5	V52.8.8
Extrapolation	Advanced Extrapolation	
Phantom	Modular Flat Phantom	
Distance Dipole Center - TSL	10 mm	with Spacer
Zoom Scan Resolution	$dx, dy, dz = 5$ mm	
Frequency	1900 MHz $\pm$ 1 MHz	

**Head TSL parameters**

The following parameters and calculations were applied.

	Temperature	Permittivity	Conductivity
Nominal Head TSL parameters	22.0 °C	40.0	1.40 mho/m
Measured Head TSL parameters	(22.0 $\pm$ 0.2) °C	38.9 $\pm$ 6 %	1.37 mho/m $\pm$ 6 %
Head TSL temperature change during test	< 0.5 °C	---	---

**SAR result with Head TSL**

SAR averaged over 1 cm <sup>3</sup> (1 g) of Head TSL	Condition	
SAR measured	250 mW input power	10.2 W/kg
SAR for nominal Head TSL parameters	normalized to 1W	41.1 W/kg $\pm$ 17.0 % (k=2)

SAR averaged over 10 cm <sup>3</sup> (10 g) of Head TSL	condition	
SAR measured	250 mW input power	5.33 W/kg
SAR for nominal Head TSL parameters	normalized to 1W	21.4 W/kg $\pm$ 16.5 % (k=2)

**Body TSL parameters**

The following parameters and calculations were applied.

	Temperature	Permittivity	Conductivity
Nominal Body TSL parameters	22.0 °C	53.3	1.52 mho/m
Measured Body TSL parameters	(22.0 $\pm$ 0.2) °C	52.7 $\pm$ 6 %	1.51 mho/m $\pm$ 6 %
Body TSL temperature change during test	< 0.5 °C	---	---

**SAR result with Body TSL**

SAR averaged over 1 cm <sup>3</sup> (1 g) of Body TSL	Condition	
SAR measured	250 mW input power	10.2 W/kg
SAR for nominal Body TSL parameters	normalized to 1W	40.9 W/kg $\pm$ 17.0 % (k=2)

SAR averaged over 10 cm <sup>3</sup> (10 g) of Body TSL	condition	
SAR measured	250 mW input power	5.41 W/kg
SAR for nominal Body TSL parameters	normalized to 1W	21.7 W/kg $\pm$ 16.5 % (k=2)

**Appendix (Additional assessments outside the scope of SCS 0108)**

**Antenna Parameters with Head TSL**

Impedance, transformed to feed point	51.3 $\Omega$ + 5.2 j $\Omega$
Return Loss	- 25.5 dB

**Antenna Parameters with Body TSL**

Impedance, transformed to feed point	47.4 $\Omega$ + 5.5 j $\Omega$
Return Loss	- 24.2 dB

**General Antenna Parameters and Design**

Electrical Delay (one direction)	1.195 ns
----------------------------------	----------

After long term use with 100W radiated power, only a slight warming of the dipole near the feedpoint can be measured.

The dipole is made of standard semirigid coaxial cable. The center conductor of the feeding line is directly connected to the second arm of the dipole. The antenna is therefore short-circuited for DC-signals. On some of the dipoles, small end caps are added to the dipole arms in order to improve matching when loaded according to the position as explained in the "Measurement Conditions" paragraph. The SAR data are not affected by this change. The overall dipole length is still according to the Standard.

No excessive force must be applied to the dipole arms, because they might bend or the soldered connections near the feedpoint may be damaged.

**Additional EUT Data**

Manufactured by	SPEAG
Manufactured on	March 17, 2003

**DASY5 Validation Report for Head TSL**

Date: 20.05.2015

Test Laboratory: SPEAG, Zurich, Switzerland

**DUT: Dipole 1900 MHz; Type: D1900V2; Serial: D1900V2 - SN: 5d032**

Communication System: UID 0 - CW; Frequency: 1900 MHz

Medium parameters used:  $f = 1900 \text{ MHz}$ ;  $\sigma = 1.37 \text{ S/m}$ ;  $\epsilon_r = 38.9$ ;  $\rho = 1000 \text{ kg/m}^3$

Phantom section: Flat Section

Measurement Standard: DASY5 (IEEE/IEC/ANSI C63.19-2011)

DASY52 Configuration:

- Probe: ES3DV3 - SN3205; ConvF(5, 5, 5); Calibrated: 30.12.2014;
- Sensor-Surface: 3mm (Mechanical Surface Detection)
- Electronics: DAE4 Sn601; Calibrated: 18.08.2014
- Phantom: Flat Phantom 5.0 (front); Type: QD000P50AA; Serial: 1001
- DASY52 52.8.8(1222); SEMCAD X 14.6.10(7331)

**Dipole Calibration for Head Tissue/Pin=250 mW, d=10mm/Zoom Scan (7x7x7)/Cube 0:**

Measurement grid: dx=5mm, dy=5mm, dz=5mm

Reference Value = 99.00 V/m; Power Drift = 0.04 dB

Peak SAR (extrapolated) = 18.6 W/kg

**SAR(1 g) = 10.2 W/kg; SAR(10 g) = 5.33 W/kg**

Maximum value of SAR (measured) = 12.7 W/kg

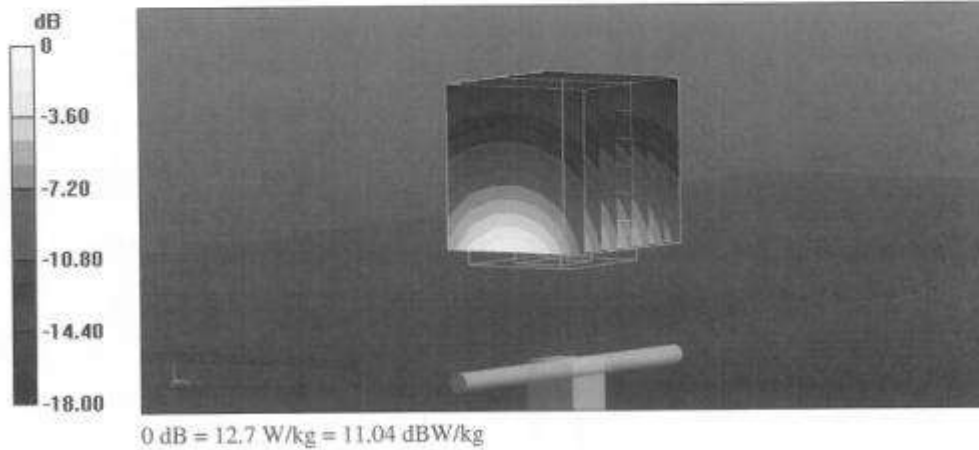

Impedance Measurement Plot for Head TSL

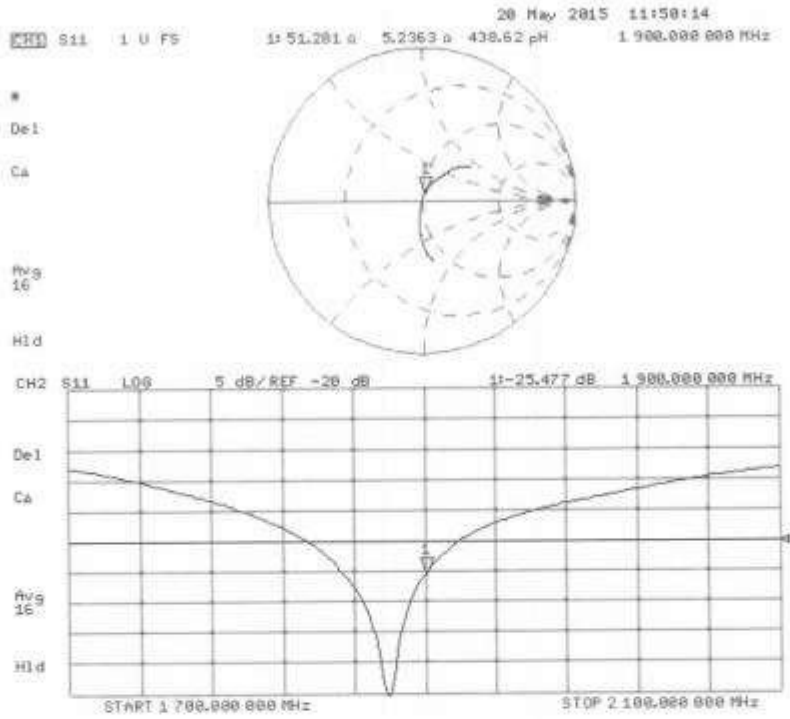

**DASY5 Validation Report for Body TSL**

Date: 20.05.2015

Test Laboratory: SPEAG, Zurich, Switzerland

**DUT: Dipole 1900 MHz; Type: D1900V2; Serial: D1900V2 - SN: 5d032**

Communication System: UID 0 - CW; Frequency: 1900 MHz

Medium parameters used:  $f = 1900$  MHz;  $\sigma = 1.51$  S/m;  $\epsilon_r = 52.7$ ;  $\rho = 1000$  kg/m<sup>3</sup>

Phantom section: Flat Section

Measurement Standard: DASY5 (IEEE/IEC/ANSI C63.19-2011)

DASY52 Configuration:

- Probe: ES3DV3 - SN3205; ConvF(4.65, 4.65, 4.65); Calibrated: 30.12.2014;
- Sensor-Surface: 3mm (Mechanical Surface Detection)
- Electronics: DAE4 Sn601; Calibrated: 18.08.2014
- Phantom: Flat Phantom 5.0 (back); Type: QD000P50AA; Serial: 1002
- DASY52 52.8.8(1222); SEMCAD X 14.6.10(7331)

**Dipole Calibration for Body Tissue/Pin=250 mW, d=10mm/Zoom Scan (7x7x7)/Cube 0:**

Measurement grid: dx=5mm, dy=5mm, dz=5mm

Reference Value = 96.54 V/m; Power Drift = 0.01 dB

Peak SAR (extrapolated) = 17.3 W/kg

**SAR(1 g) = 10.2 W/kg; SAR(10 g) = 5.41 W/kg**

Maximum value of SAR (measured) = 12.8 W/kg

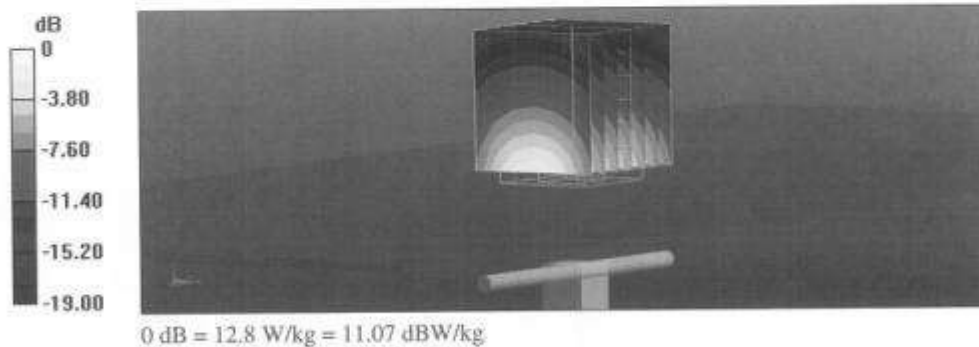

Impedance Measurement Plot for Body TSL

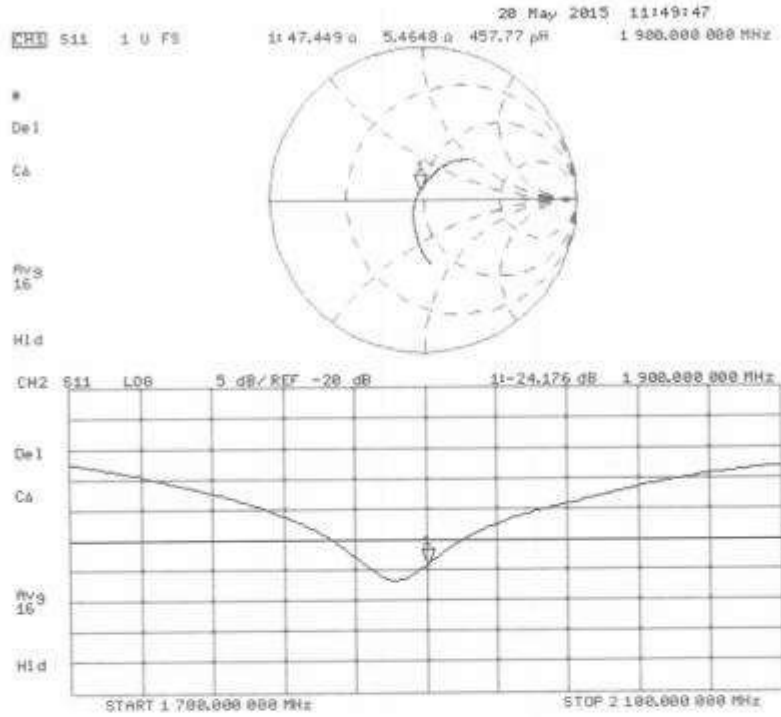

**Calibration Laboratory of  
Schmid & Partner  
Engineering AG**  
Zeughausstrasse 43, 8004 Zurich, Switzerland



**S** Schweizerischer Kalibrierdienst  
**S** Service suisse d'étalonnage  
**C** Servizio svizzero di taratura  
**S** Swiss Calibration Service

Accredited by the Swiss Accreditation Service (SAS)  
The Swiss Accreditation Service is one of the signatories to the EA  
Multilateral Agreement for the recognition of calibration certificates

Accreditation No.: **SCS 0108**

Client **HCT (Dymstec)**

Certificate No: **D2450V2-743\_May15**

**CALIBRATION CERTIFICATE**

Object **D2450V2 - SN: 743**

Calibration procedure(s) **QA CAL-05.v9  
Calibration procedure for dipole validation kits above 700 MHz**

Calibration date: **May 19, 2015**

This calibration certificate documents the traceability to national standards, which realize the physical units of measurements (SI).  
The measurements and the uncertainties with confidence probability are given on the following pages and are part of the certificate.

All calibrations have been conducted in the closed laboratory facility: environment temperature (22 ± 3)°C and humidity < 70%.

Calibration Equipment used (M&TE critical for calibration)

Primary Standards	ID #	Cal Date (Certificate No.)	Scheduled Calibration
Power meter EPM-442A	GB37480704	07-Oct-14 (No. 217-02020)	Oct-15
Power sensor HP 8481A	US37292783	07-Oct-14 (No. 217-02020)	Oct-15
Power sensor HP 8481A	MY41092317	07-Oct-14 (No. 217-02021)	Oct-15
Reference 20 dB Attenuator	SN: 5058 (20K)	01-Apr-15 (No. 217-02131)	Mar-16
Type-N mismatch combination	SN: 5047.2 / 05327	01-Apr-15 (No. 217-02134)	Mar-16
Reference Probe ES3DV3	SN: 3205	30-Dec-14 (No. ES3-3205_Dec14)	Dec-15
DAE4	SN: 601	18-Aug-14 (No. DAE4-601_Aug14)	Aug-15
Secondary Standards	ID #	Check Date (in house)	Scheduled Check
RF generator R&S SMT-06	100005	04-Aug-99 (in house check Oct-13)	In house check: Oct-16
Network Analyzer HP 8753E	US37390585 S4206	18-Oct-01 (in house check Oct-14)	In house check: Oct-15

Calibrated by: **Name: Michael Weber, Function: Laboratory Technician, Signature: M. Weber**

Approved by: **Name: Katja Pokovic, Function: Technical Manager, Signature: K. Pokovic**

Issued: May 20, 2015

This calibration certificate shall not be reproduced except in full without written approval of the laboratory.

**Calibration Laboratory of  
Schmid & Partner  
Engineering AG**  
Zeughausstrasse 43, 8004 Zurich, Switzerland



**S** Schweizerischer Kalibrierdienst  
**C** Service suisse d'étalonnage  
**S** Servizio svizzero di taratura  
**S** Swiss Calibration Service

Accredited by the Swiss Accreditation Service (SAS)  
The Swiss Accreditation Service is one of the signatories to the EA  
Multilateral Agreement for the recognition of calibration certificates

Accreditation No.: **SCS 0108**

**Glossary:**

TSL tissue simulating liquid  
ConvF sensitivity in TSL / NORM x,y,z  
N/A not applicable or not measured

**Calibration is Performed According to the Following Standards:**

- a) IEEE Std 1528-2013, "IEEE Recommended Practice for Determining the Peak Spatial-Averaged Specific Absorption Rate (SAR) in the Human Head from Wireless Communications Devices: Measurement Techniques", June 2013
- b) IEC 62209-1, "Procedure to measure the Specific Absorption Rate (SAR) for hand-held devices used in close proximity to the ear (frequency range of 300 MHz to 3 GHz)", February 2005
- c) KDB 865664, "SAR Measurement Requirements for 100 MHz to 6 GHz"

**Additional Documentation:**

- d) DASY4/5 System Handbook

**Methods Applied and Interpretation of Parameters:**

- *Measurement Conditions:* Further details are available from the Validation Report at the end of the certificate. All figures stated in the certificate are valid at the frequency indicated.
- *Antenna Parameters with TSL:* The dipole is mounted with the spacer to position its feed point exactly below the center marking of the flat phantom section, with the arms oriented parallel to the body axis.
- *Feed Point Impedance and Return Loss:* These parameters are measured with the dipole positioned under the liquid filled phantom. The impedance stated is transformed from the measurement at the SMA connector to the feed point. The Return Loss ensures low reflected power. No uncertainty required.
- *Electrical Delay:* One-way delay between the SMA connector and the antenna feed point. No uncertainty required.
- *SAR measured:* SAR measured at the stated antenna input power.
- *SAR normalized:* SAR as measured, normalized to an input power of 1 W at the antenna connector.
- *SAR for nominal TSL parameters:* The measured TSL parameters are used to calculate the nominal SAR result.

The reported uncertainty of measurement is stated as the standard uncertainty of measurement multiplied by the coverage factor  $k=2$ , which for a normal distribution corresponds to a coverage probability of approximately 95%.

**Measurement Conditions**

DASY system configuration, as far as not given on page 1.

DASY Version	DASY5	V52.8.8
Extrapolation	Advanced Extrapolation	
Phantom	Modular Flat Phantom	
Distance Dipole Center - TSL	10 mm	with Spacer
Zoom Scan Resolution	dx, dy, dz = 5 mm	
Frequency	2450 MHz ± 1 MHz	

**Head TSL parameters**

The following parameters and calculations were applied.

	Temperature	Permittivity	Conductivity
Nominal Head TSL parameters	22.0 °C	39.2	1.80 mho/m
Measured Head TSL parameters	(22.0 ± 0.2) °C	37.9 ± 6 %	1.84 mho/m ± 6 %
Head TSL temperature change during test	< 0.5 °C	----	----

**SAR result with Head TSL**

SAR averaged over 1 cm <sup>3</sup> (1 g) of Head TSL	Condition	
SAR measured	250 mW input power	13.6 W/kg
SAR for nominal Head TSL parameters	normalized to 1W	<b>53.4 W/kg ± 17.0 % (k=2)</b>

SAR averaged over 10 cm <sup>3</sup> (10 g) of Head TSL	condition	
SAR measured	250 mW input power	6.32 W/kg
SAR for nominal Head TSL parameters	normalized to 1W	<b>25.0 W/kg ± 16.5 % (k=2)</b>

**Body TSL parameters**

The following parameters and calculations were applied.

	Temperature	Permittivity	Conductivity
Nominal Body TSL parameters	22.0 °C	52.7	1.95 mho/m
Measured Body TSL parameters	(22.0 ± 0.2) °C	50.7 ± 6 %	2.03 mho/m ± 6 %
Body TSL temperature change during test	≥ 0.5 °C	----	----

**SAR result with Body TSL**

SAR averaged over 1 cm <sup>3</sup> (1 g) of Body TSL	Condition	
SAR measured	250 mW input power	13.4 W/kg
SAR for nominal Body TSL parameters	normalized to 1W	<b>52.1 W/kg ± 17.0 % (k=2)</b>

SAR averaged over 10 cm <sup>3</sup> (10 g) of Body TSL	condition	
SAR measured	250 mW input power	6.20 W/kg
SAR for nominal Body TSL parameters	normalized to 1W	<b>24.4 W/kg ± 16.5 % (k=2)</b>

**Appendix (Additional assessments outside the scope of SCS 0108)**

**Antenna Parameters with Head TSL**

Impedance, transformed to feed point	54.2 $\Omega$ + 4.4 $j\Omega$
Return Loss	- 24.6 dB

**Antenna Parameters with Body TSL**

Impedance, transformed to feed point	51.4 $\Omega$ + 6.1 $j\Omega$
Return Loss	- 24.2 dB

**General Antenna Parameters and Design**

Electrical Delay (one direction)	1.160 ns
----------------------------------	----------

After long term use with 100W radiated power, only a slight warming of the dipole near the feedpoint can be measured.

The dipole is made of standard semirigid coaxial cable. The center conductor of the feeding line is directly connected to the second arm of the dipole. The antenna is therefore short-circuited for DC-signals. On some of the dipoles, small end caps are added to the dipole arms in order to improve matching when loaded according to the position as explained in the "Measurement Conditions" paragraph. The SAR data are not affected by this change. The overall dipole length is still according to the Standard.

No excessive force must be applied to the dipole arms, because they might bend or the soldered connections near the feedpoint may be damaged.

**Additional EUT Data**

Manufactured by	SPEAG
Manufactured on	December 01, 2003

**DASY5 Validation Report for Head TSL**

Date: 19.05.2015

Test Laboratory: SPEAG, Zurich, Switzerland

**DUT: Dipole 2450 MHz; Type: D2450V2; Serial: D2450V2 - SN: 743**

Communication System: UID 0 - CW; Frequency: 2450 MHz  
Medium parameters used:  $f = 2450$  MHz;  $\sigma = 1.84$  S/m;  $\epsilon_r = 37.9$ ;  $\rho = 1000$  kg/m<sup>3</sup>  
Phantom section: Flat Section  
Measurement Standard: DASY5 (IEEE/IEC/ANSI C63.19-2011)

**DASY52 Configuration:**

- Probe: ES3DV3 - SN3205; ConvF(4.54, 4.54, 4.54); Calibrated: 30.12.2014;
- Sensor-Surface: 3mm (Mechanical Surface Detection)
- Electronics: DAE4 Sn601; Calibrated: 18.08.2014
- Phantom: Flat Phantom 5.0 (front); Type: QD000P50AA; Serial: 1001
- DASY52 52.8.8(1222); SEMCAD X 14.6.10(7331)

**Dipole Calibration for Head Tissue/Pin=250 mW, d=10mm/Zoom Scan (7x7x7)/Cube 0:**

Measurement grid: dx=5mm, dy=5mm, dz=5mm  
Reference Value = 101.4 V/m; Power Drift = 0.04 dB  
Peak SAR (extrapolated) = 28.0 W/kg  
**SAR(1 g) = 13.6 W/kg; SAR(10 g) = 6.32 W/kg**  
Maximum value of SAR (measured) = 17.7 W/kg

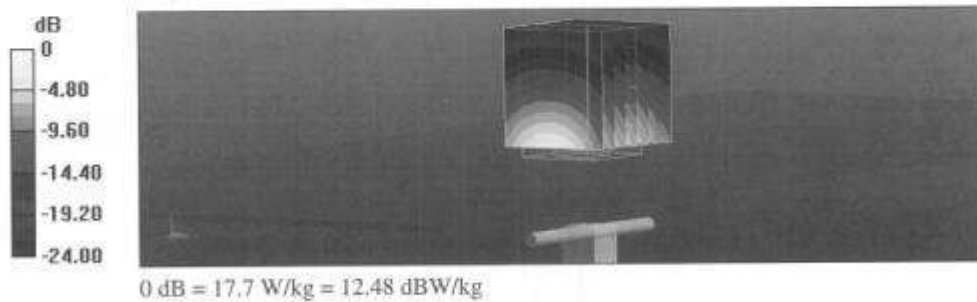

Impedance Measurement Plot for Head TSL

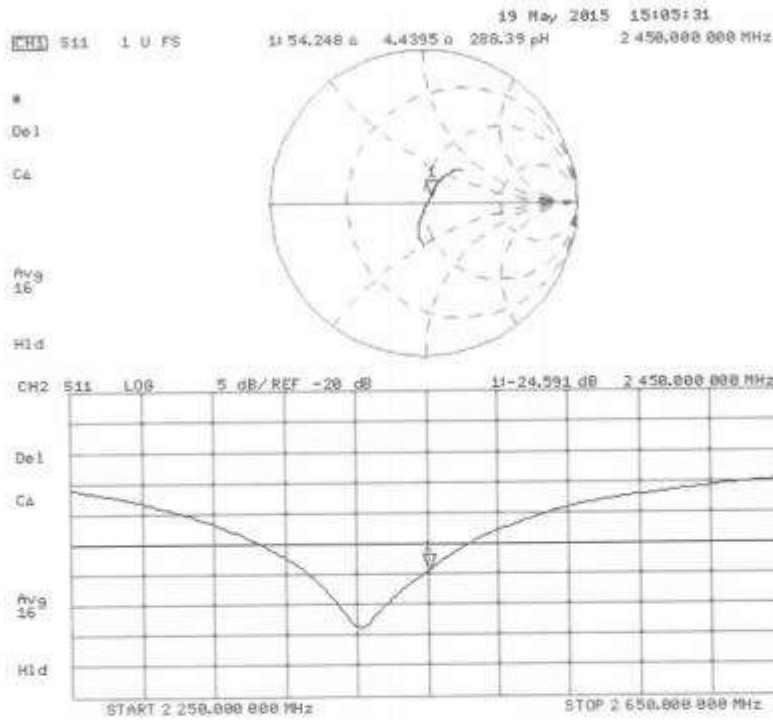

**DASY5 Validation Report for Body TSL**

Date: 19.05.2015

Test Laboratory: SPEAG, Zurich, Switzerland

**DUT: Dipole 2450 MHz; Type: D2450V2; Serial: D2450V2 - SN: 743**

Communication System: UID 0 - CW; Frequency: 2450 MHz  
Medium parameters used:  $f = 2450$  MHz;  $\sigma = 2.03$  S/m;  $\epsilon_r = 50.7$ ;  $\rho = 1000$  kg/m<sup>3</sup>  
Phantom section: Flat Section  
Measurement Standard: DASY5 (IEEE/IEC/ANSI C63.19-2011)

**DASY52 Configuration:**

- Probe: ES3DV3 - SN3205; ConvF(4.32, 4.32, 4.32); Calibrated: 30.12.2014;
- Sensor-Surface: 3mm (Mechanical Surface Detection)
- Electronics: DAE4 Sn601; Calibrated: 18.08.2014
- Phantom: Flat Phantom 5.0 (back); Type: QD000P50AA; Serial: 1002
- DASY52 52.8.8(1222); SEMCAD X 14.6.10(7331)

**Dipole Calibration for Body Tissue/Pin=250 mW, d=10mm/Zoom Scan (7x7x7)/Cube 0:**

Measurement grid: dx=5mm, dy=5mm, dz=5mm  
Reference Value = 96.12 V/m; Power Drift = -0.02 dB  
Peak SAR (extrapolated) = 27.9 W/kg  
**SAR(1 g) = 13.4 W/kg; SAR(10 g) = 6.2 W/kg**  
Maximum value of SAR (measured) = 17.7 W/kg



Impedance Measurement Plot for Body TSL

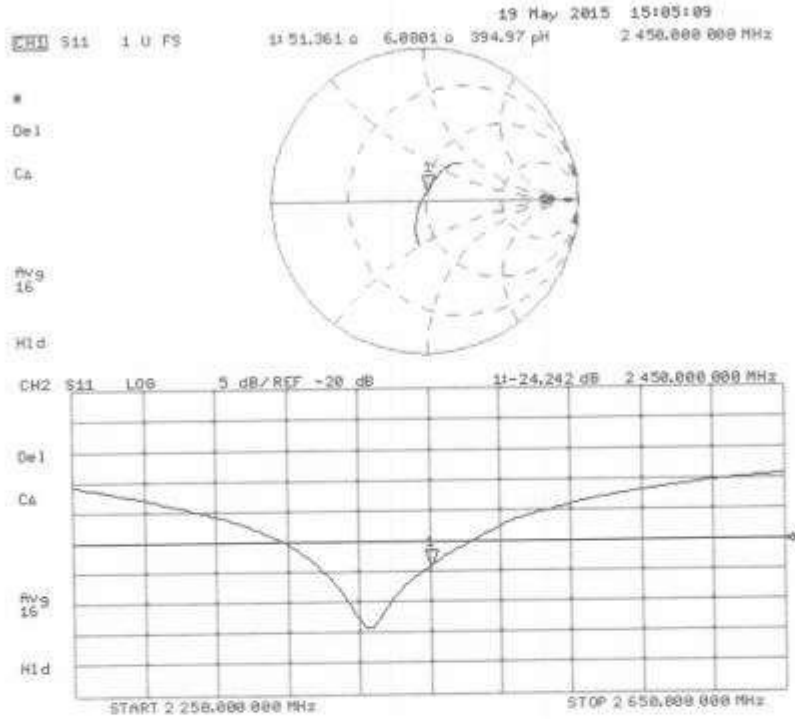

**Calibration Laboratory of  
Schmid & Partner  
Engineering AG**  
Zeughausstrasse 43, 8004 Zurich, Switzerland



**S** Schweizerischer Kalibrierdienst  
**C** Service suisse d'étalonnage  
**S** Servizio svizzero di taratura  
**S** Swiss Calibration Service

Accredited by the Swiss Accreditation Service (SAS)  
The Swiss Accreditation Service is one of the signatories to the EA  
Multilateral Agreement for the recognition of calibration certificates

Accreditation No.: **SCS 0108**

Client **HCT (Dymstec)**

Certificate No: **D2600V2-1015\_Mar15**

**CALIBRATION CERTIFICATE**

Object: **D2600V2 - SN: 1015**

Calibration procedure(s): **QA CAL-05.v9  
Calibration procedure for dipole validation kits above 700 MHz**

Calibration date: **March 25, 2015**

This calibration certificate documents the traceability to national standards, which realize the physical units of measurements (SI).  
The measurements and the uncertainties with confidence probability are given on the following pages and are part of the certificate.

All calibrations have been conducted in the closed laboratory facility: environment temperature (22 ± 3)°C and humidity < 70%.

Calibration Equipment used (M&TE critical for calibration)

Primary Standards	ID #	Cal Date (Certificate No.)	Scheduled Calibration
Power meter EPM-442A	GB37480704	07-Oct-14 (No. 217-02020)	Oct-15
Power sensor HP 8481A	US37292783	07-Oct-14 (No. 217-02020)	Oct-15
Power sensor HP 8481A	MY41092317	07-Oct-14 (No. 217-02021)	Oct-15
Reference 20 dB Attenuator	SN: 5058 (20k)	03-Apr-14 (No. 217-01918)	Apr-15
Type-N mismatch combination	SN: 5047.2 / 06327	03-Apr-14 (No. 217-01921)	Apr-15
Reference Probe ES3DV3	SN: 3205	30-Dec-14 (No. ES3-3205_Dec14)	Dec-15
DAE4	SN: 601	18-Aug-14 (No. DAE4-601_Aug14)	Aug-15
Secondary Standards	ID #	Check Date (in house)	Scheduled Check
RF generator R&S SMT-06	100005	04-Aug-99 (in house check Oct-13)	In house check: Oct-16
Network Analyzer HP 8753E	US37390585 S4206	18-Oct-01 (in house check Oct-14)	In house check: Oct-15

Calibrated by:	Name <b>Jeton Kastrati</b>	Function <b>Laboratory Technician</b>	Signature 
Approved by:	Name <b>Katja Pokovic</b>	Technical Manager	

Issued: March 25, 2015

This calibration certificate shall not be reproduced except in full without written approval of the laboratory.

**Calibration Laboratory of  
Schmid & Partner  
Engineering AG**  
Zeughausstrasse 43, 8004 Zurich, Switzerland



**S** Schweizerischer Kalibrierdienst  
**C** Service suisse d'étalonnage  
**S** Servizio svizzero di taratura  
**S** Swiss Calibration Service

Accredited by the Swiss Accreditation Service (SAS)  
The Swiss Accreditation Service is one of the signatories to the EA  
Multilateral Agreement for the recognition of calibration certificates

Accreditation No.: **SCS 0108**

**Glossary:**

TSL	tissue simulating liquid
ConvF	sensitivity in TSL / NORM x,y,z
N/A	not applicable or not measured

**Calibration is Performed According to the Following Standards:**

- IEEE Std 1528-2013, "IEEE Recommended Practice for Determining the Peak Spatial-Averaged Specific Absorption Rate (SAR) in the Human Head from Wireless Communications Devices: Measurement Techniques", June 2013
- IEC 62209-1, "Procedure to measure the Specific Absorption Rate (SAR) for hand-held devices used in close proximity to the ear (frequency range of 300 MHz to 3 GHz)", February 2005
- KDB 865664, "SAR Measurement Requirements for 100 MHz to 6 GHz"

**Additional Documentation:**

- DASY4/5 System Handbook

**Methods Applied and Interpretation of Parameters:**

- Measurement Conditions:** Further details are available from the Validation Report at the end of the certificate. All figures stated in the certificate are valid at the frequency indicated.
- Antenna Parameters with TSL:** The dipole is mounted with the spacer to position its feed point exactly below the center marking of the flat phantom section, with the arms oriented parallel to the body axis.
- Feed Point Impedance and Return Loss:** These parameters are measured with the dipole positioned under the liquid filled phantom. The impedance stated is transformed from the measurement at the SMA connector to the feed point. The Return Loss ensures low reflected power. No uncertainty required.
- Electrical Delay:** One-way delay between the SMA connector and the antenna feed point. No uncertainty required.
- SAR measured:** SAR measured at the stated antenna input power.
- SAR normalized:** SAR as measured, normalized to an input power of 1 W at the antenna connector.
- SAR for nominal TSL parameters:** The measured TSL parameters are used to calculate the nominal SAR result.

The reported uncertainty of measurement is stated as the standard uncertainty of measurement multiplied by the coverage factor  $k=2$ , which for a normal distribution corresponds to a coverage probability of approximately 95%.

**Measurement Conditions**

DASY system configuration, as far as not given on page 1:

DASY Version	DASY5	V52.8.8
Extrapolation	Advanced Extrapolation	
Phantom	Modular Flat Phantom	
Distance Dipole Center - TSL	10 mm	with Spacer
Zoom Scan Resolution	dx, dy, dz = 5 mm	
Frequency	2600 MHz ± 1 MHz	

**Head TSL parameters**

The following parameters and calculations were applied.

	Temperature	Permittivity	Conductivity
Nominal Head TSL parameters	22.0 °C	39.0	1.96 mho/m
Measured Head TSL parameters	(22.0 ± 0.2) °C	37.2 ± 6 %	2.00 mho/m ± 6 %
Head TSL temperature change during test	< 0.5 °C	----	----

**SAR result with Head TSL**

SAR averaged over 1 cm <sup>3</sup> (1 g) of Head TSL	Condition	
SAR measured	250 mW input power	14.4 W/kg
SAR for nominal Head TSL parameters	normalized to 1W	56.5 W/kg ± 17.0 % (k=2)

SAR averaged over 10 cm <sup>3</sup> (10 g) of Head TSL	condition	
SAR measured	250 mW input power	6.40 W/kg
SAR for nominal Head TSL parameters	normalized to 1W	25.3 W/kg ± 16.5 % (k=2)

**Body TSL parameters**

The following parameters and calculations were applied.

	Temperature	Permittivity	Conductivity
Nominal Body TSL parameters	22.0 °C	52.5	2.16 mho/m
Measured Body TSL parameters	(22.0 ± 0.2) °C	50.3 ± 6 %	2.20 mho/m ± 6 %
Body TSL temperature change during test	< 0.5 °C	----	----

**SAR result with Body TSL**

SAR averaged over 1 cm <sup>3</sup> (1 g) of Body TSL	Condition	
SAR measured	250 mW input power	14.1 W/kg
SAR for nominal Body TSL parameters	normalized to 1W	55.4 W/kg ± 17.0 % (k=2)

SAR averaged over 10 cm <sup>3</sup> (10 g) of Body TSL	condition	
SAR measured	250 mW input power	6.27 W/kg
SAR for nominal Body TSL parameters	normalized to 1W	24.8 W/kg ± 16.5 % (k=2)

**Appendix (Additional assessments outside the scope of SCS 0108)**

**Antenna Parameters with Head TSL**

Impedance, transformed to feed point	50.0 $\Omega$ - 2.1 j $\Omega$
Return Loss	- 33.5 dB

**Antenna Parameters with Body TSL**

Impedance, transformed to feed point	46.6 $\Omega$ - 1.9 j $\Omega$
Return Loss	- 27.8 dB

**General Antenna Parameters and Design**

Electrical Delay (one direction)	1,150 ns
----------------------------------	----------

After long term use with 100W radiated power, only a slight warming of the dipole near the feedpoint can be measured.

The dipole is made of standard semirigid coaxial cable. The center conductor of the feeding line is directly connected to the second arm of the dipole. The antenna is therefore short-circuited for DC-signals. On some of the dipoles, small end caps are added to the dipole arms in order to improve matching when loaded according to the position as explained in the "Measurement Conditions" paragraph. The SAR data are not affected by this change. The overall dipole length is still according to the Standard.

No excessive force must be applied to the dipole arms, because they might bend or the soldered connections near the feedpoint may be damaged.

**Additional EUT Data**

Manufactured by	SPEAG
Manufactured on:	October 30, 2007

**DASY5 Validation Report for Head TSL**

Date: 20.03.2015

Test Laboratory: SPEAG, Zurich, Switzerland

**DUT: Dipole 2600 MHz; Type: D2600V2; Serial: D2600V2 - SN: 1015**

Communication System: UID 0 - CW; Frequency: 2600 MHz

Medium parameters used:  $f = 2600$  MHz;  $\sigma = 2$  S/m;  $\epsilon_r = 37.2$ ;  $\rho = 1000$  kg/m<sup>3</sup>

Phantom section: Flat Section

Measurement Standard: DASY5 (IEEE/IEC/ANSI C63.19-2011)

**DASY52 Configuration:**

- Probe: ES3DV3 - SN3205; ConvF(4.49, 4.49, 4.49); Calibrated: 30.12.2014;
- Sensor-Surface: 3mm (Mechanical Surface Detection)
- Electronics: DAE4 Sn601; Calibrated: 18.08.2014
- Phantom: Flat Phantom 5.0 (front); Type: QD000P50AA; Serial: 1001
- DASY52 52.8.8(1222); SEMCAD X 14.6.10(7331)

**Dipole Calibration for Head/Pin=250 mW, d=10mm/Zoom Scan (7x7x7)/Cube 0:**

Measurement grid: dx=5mm, dy=5mm, dz=5mm

Reference Value = 102.2 V/m; Power Drift = 0.03 dB

Peak SAR (extrapolated) = 30.4 W/kg

**SAR(1 g) = 14.4 W/kg; SAR(10 g) = 6.4 W/kg**

Maximum value of SAR (measured) = 18.9 W/kg

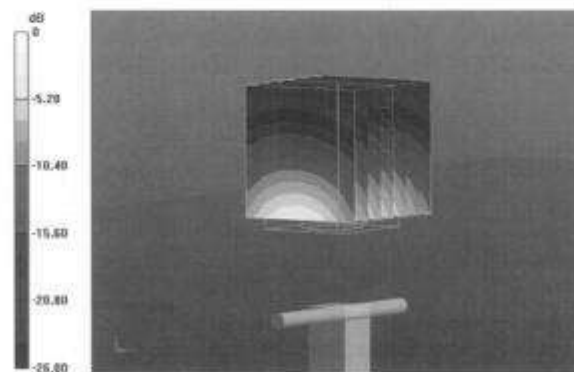

0 dB = 18.9 W/kg = 12.76 dBW/kg

Impedance Measurement Plot for Head TSL

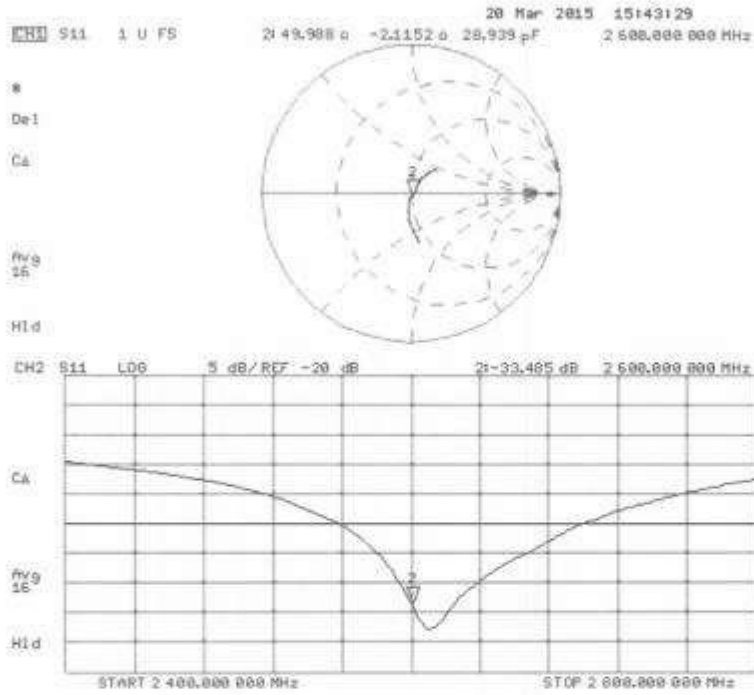

**DASY5 Validation Report for Body TSL**

Date: 25.03.2015

Test Laboratory: SPEAG, Zurich, Switzerland

**DUT: Dipole 2600 MHz; Type: D2600V2; Serial: D2600V2 - SN: 1015**

Communication System: UID 0 - CW; Frequency: 2600 MHz  
 Medium parameters used:  $f = 2600$  MHz;  $\sigma = 2.2$  S/m;  $\epsilon_r = 50.3$ ;  $\rho = 1000$  kg/m<sup>3</sup>  
 Phantom section: Flat Section  
 Measurement Standard: DASY5 (IEEE/IEC/ANSI C63.19-2011)

**DASY52 Configuration:**

- Probe: ES3DV3 - SN3205; ConvF(4.13, 4.13, 4.13); Calibrated: 30.12.2014;
- Sensor-Surface: 3mm (Mechanical Surface Detection)
- Electronics: DAE4 Sn601; Calibrated: 18.08.2014
- Phantom: Flat Phantom 5.0 (back); Type: QD000P50AA; Serial: 1002
- DASY52 52.8.8(1222); SEMCAD X 14.6.10(7331)

**Dipole Calibration for Body/Pin=250 mW, d=10mm/Zoom Scan (7x7x7)/Cube 0:**

Measurement grid:  $dx=5$ mm,  $dy=5$ mm,  $dz=5$ mm  
 Reference Value = 96.03 V/m; Power Drift = 0.03 dB  
 Peak SAR (extrapolated) = 29.2 W/kg  
**SAR(1 g) = 14.1 W/kg; SAR(10 g) = 6.27 W/kg**  
 Maximum value of SAR (measured) = 18.6 W/kg

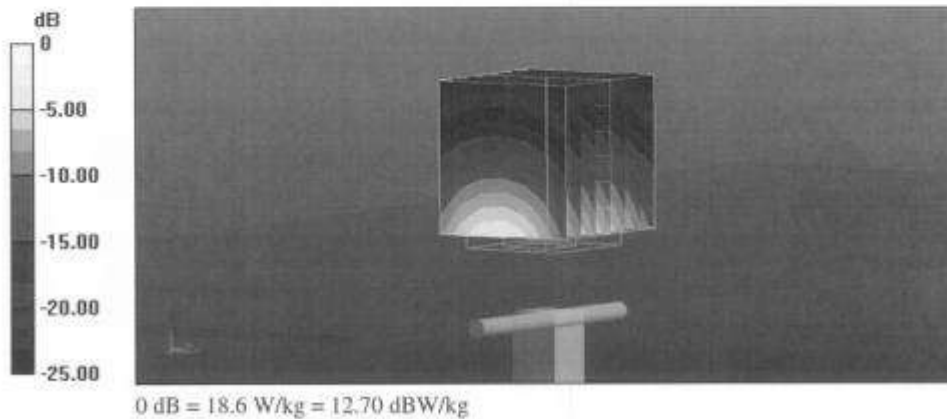

Impedance Measurement Plot for Body TSL

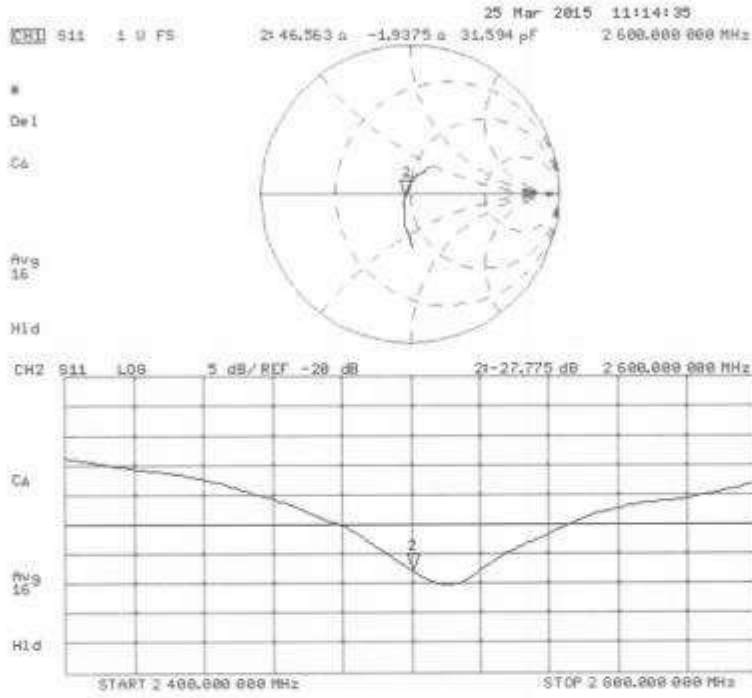

## Attachment 5. – SAR Tissue Characterization

The brain and muscle mixtures consist of a viscous gel using hydrox-ethyl cellulose (HEC) gelling agent and saline solution (see Table 3.1). Preservation with a bactericide is added and visual inspection is made to make sure air bubbles are not trapped during the mixing process. The mixture is calibrated to obtain proper dielectric constant (permittivity) and conductivity of the desired tissue. The mixture characterizations used for the brain and muscle tissue simulating liquids are according to the data by C. Gabriel and G. Hartsgrove.

Ingredients (% by weight)	Frequency (MHz)							
	835		1 900		2 450 – 2 700		5 200 - 5 800	
Tissue Type	Head	Body	Head	Body	Head	Body	Head	Body
Water	40.45	53.06	54.9	70.17	71.88	73.2	65.52	78.66
Salt (NaCl)	1.45	0.94	0.18	0.39	0.16	0.1	0.0	0.0
Sugar	57.0	44.9	0.0	0	0.0	0.0	0.0	0.0
HEC	1.0	1.0	0.0	0	0.0	0.0	0.0	0.0
Bactericide	0.1	0.1	0.0	0	0.0	0.0	0.0	0.0
Triton X-100	0.0	0.0	0.0	0.0	19.97	0.0	17.24	10.67
DGBE	0.0	0.0	44.92	29.44	7.99	26.7	0.0	0.0
Diethylene glycol hexyl ether	-	-	-	-	-	-	17.24	10.67

Salt: 99 % Pure Sodium Chloride                      Sugar: 98 % Pure Sucrose  
 Water: De-ionized, 16M resistivity                      HEC: Hydroxyethyl Cellulose  
 DGBE: 99 % Di(ethylene glycol) butyl ether,[2-(2-butoxyethoxy) ethanol]  
 Triton X-100(ultra pure): Polyethylene glycol mono[4-(1,1,3,3-tetramethylbutyl)phenyl] ether

### Composition of the Tissue Equivalent Matter

## Attachment 6. – SAR SYSTEM VALIDATION

Per FCC KCB 865664 D02v01r02, SAR system validation status should be document to confirm measurement accuracy. The SAR systems (including SAR probes, system components and software versions) used for this device were validated against its performance specifications prior to the SAR measurements. Reference dipoles were used with the required tissue- equivalent media for system validation, according to the procedures outlined in IEEE 1528-2013 and FCC KDB 865664 D01v01r04. Since SAR probe calibrations are frequency dependent, each probe calibration point was validated at a frequency within the valid frequency range of the probe calibration point, using the system that normally operates with the probe for routine SAR measurements and according to the required tissue-equivalent media.

A tabulated summary of the system validation status including the validation date(s), measurement frequencies, SAR probes and tissue dielectric parameters has been included.

SAR System No.	Probe	Probe Type	Probe Calibration Point			Dipole	Date	Dielectric Parameters		CW Validation			Modulation Validation		
								Measured Permittivity	Measured Conductivity	Sensitivity	Probe Linearity	Probe Isotropy	MOD. Type	Duty Factor	PAR
1	3863	EX3DV4	Head	835	4d165	12/01/2015	40.8	0.89	PASS	PASS	PASS	GMSK	PASS	N/A	
1	3863	EX3DV4	Body	835	4d165	12/02/2015	54.8	0.98	PASS	PASS	PASS	GMSK	PASS	N/A	
8	3967	EX3DV4	Head	1900	5d032	12/28/2015	40.3	1.41	PASS	PASS	PASS	GMSK	PASS	N/A	
1	3863	EX3DV4	Body	1900	5d032	09/15/2015	52.6	1.54	PASS	PASS	PASS	GMSK	PASS	N/A	
8	3967	EX3DV4	Head	2450	743	12/28/2015	39.3	1.79	PASS	PASS	PASS	OFDM	N/A	PASS	
8	3967	EX3DV4	Body	2450	743	12/30/2015	52.9	1.97	PASS	PASS	PASS	OFDM	N/A	PASS	
8	3967	EX3DV4	Head	2600	1015	12/28/2015	39.2	1.95	PASS	PASS	PASS	NA	N/A	NA	
9	3967	EX3DV4	Body	2600	1015	12/30/2015	53.1	2.17	PASS	PASS	PASS	NA	N/A	NA	

**SAR System Validation Summary**

**Note;**

All measurement were performed using probes calibrated for CW signal only. Modulations in the table above represent test configurations for which the measurement system has been validated per FCC KDB Publication 865664 D01v01r04. SAR system were validated for modulated signals with a periodic duty cycle, such as GMSK, or with a high peak to average ratio (>5 dB), such as OFDM according to KDB 865664 D01v01r04.