



## SAR EVALUATION REPORT

**Applicant Name:**  
 Samsung Electronics Co., Ltd.  
 129, Samsung-ro, Maetan dong,  
 Yeongtong-gu, Suwon-si  
 Gyeonggi-do, 16677, Korea

**Date of Testing:**  
 03/20/17 - 04/05/17  
**Test Site/Location:**  
 PCTEST Lab, Columbia, MD, USA  
**Document Serial No.:**  
 1M1703200117-01.A3L

**FCC ID:** A3LSMJ530F

**APPLICANT:** SAMSUNG ELECTRONICS CO., LTD.

**DUT Type:** Portable Handset  
**Application Type:** Certification  
**FCC Rule Part(s):** CFR §2.1093  
**Model:** SM-J530F  
**Additional Model(s):** SM-J530F/DS

Equipment Class	Band & Mode	Tx Frequency	SAR		
			1 gm Head (W/kg)	1 gm Body-Worn (W/kg)	1 gm Hotspot (W/kg)
PCE	GSM/GPRS/EDGE 850	824.20 - 848.80 MHz	< 0.1	0.21	0.20
PCE	GSM/GPRS/EDGE 1900	1850.20 - 1909.80 MHz	< 0.1	0.58	0.50
PCE	UMTS 850	826.40 - 846.60 MHz	0.11	0.26	0.36
PCE	UMTS 1750	1712.4 - 1752.6 MHz	< 0.1	0.52	0.68
PCE	UMTS 1900	1852.4 - 1907.6 MHz	0.12	0.89	1.01
PCE	LTE Band 5 (Cell)	824.7 - 848.3 MHz	< 0.1	0.39	0.49
DTS	2.4 GHz WLAN	2412 - 2462 MHz	0.79	0.13	0.27
NII	U-NII-1	5180 - 5240 MHz	N/A	N/A	N/A
NII	U-NII-2A	5260 - 5320 MHz	1.04	< 0.1	N/A
NII	U-NII-2C	5500 - 5720 MHz	0.95	< 0.1	N/A
NII	U-NII-3	5745 - 5825 MHz	0.99	< 0.1	0.90
DSS/DTS	Bluetooth	2402 - 2480 MHz	N/A		
<b>Simultaneous SAR per KDB 690783 D01v01r03:</b>			1.17	1.02	1.58

This wireless portable device has been shown to be capable of compliance for localized specific absorption rate (SAR) for uncontrolled environment/general population exposure limits specified in ANSI/IEEE C95.1-1992 and has been tested in accordance with the measurement procedures specified in Section 1.8 of this report; for North American frequency bands only.

I attest to the accuracy of data. All measurements reported herein were performed by me or were made under my supervision and are correct to the best of my knowledge and belief. I assume full responsibility for the completeness of these measurements and vouch for the qualifications of all persons taking them. Test results reported herein relate only to the item(s) tested.

Randy Ortanez  
 President





The SAR Tick is an initiative of the Mobile Manufacturers Forum (MMF). While a product may be considered eligible, use of the SAR Tick logo requires an agreement with the MMF. Further details can be obtained by emailing: [sartick@mmfai.info](mailto:sartick@mmfai.info).

<b>FCC ID:</b> A3LSMJ530F		<b>SAR EVALUATION REPORT</b>		<b>Approved by:</b> Quality Manager
<b>Document S/N:</b> 1M1703200117-01.A3L	<b>Test Dates:</b> 03/20/17 - 04/05/17	<b>DUT Type:</b> Portable Handset	Page 1 of 49	

# TABLE OF CONTENTS

1	DEVICE UNDER TEST .....	3
2	LTE INFORMATION .....	9
3	INTRODUCTION .....	10
4	DOSIMETRIC ASSESSMENT .....	11
5	DEFINITION OF REFERENCE POINTS.....	12
6	TEST CONFIGURATION POSITIONS.....	13
7	RF EXPOSURE LIMITS .....	16
8	FCC MEASUREMENT PROCEDURES.....	17
9	RF CONDUCTED POWERS .....	22
10	SYSTEM VERIFICATION.....	30
11	SAR DATA SUMMARY .....	32
12	FCC MULTI-TX AND ANTENNA SAR CONSIDERATIONS.....	40
13	SAR MEASUREMENT VARIABILITY .....	44
14	EQUIPMENT LIST.....	45
15	MEASUREMENT UNCERTAINTIES.....	46
16	CONCLUSION.....	47
17	REFERENCES .....	48
APPENDIX A: SAR TEST PLOTS		
APPENDIX B: SAR DIPOLE VERIFICATION PLOTS		
APPENDIX C: PROBE AND DIPOLE CALIBRATION CERTIFICATES		
APPENDIX D: SAR TISSUE SPECIFICATIONS		
APPENDIX E: SAR SYSTEM VALIDATION		
APPENDIX F: DUT ANTENNA DIAGRAM & SAR TEST SETUP PHOTOGRAPHS		

<b>FCC ID:</b> A3LSMJ530F		<b>SAR EVALUATION REPORT</b>		<b>Approved by:</b> Quality Manager
<b>Document S/N:</b> 1M1703200117-01.A3L	<b>Test Dates:</b> 03/20/17 - 04/05/17	<b>DUT Type:</b> Portable Handset	Page 2 of 49	

# 1 DEVICE UNDER TEST

## 1.1 Device Overview

Band & Mode	Operating Modes	Tx Frequency
GSM/GPRS/EDGE 850	Voice/Data	824.20 - 848.80 MHz
GSM/GPRS/EDGE 1900	Voice/Data	1850.20 - 1909.80 MHz
UMTS 850	Voice/Data	826.40 - 846.60 MHz
UMTS 1750	Voice/Data	1712.4 - 1752.6 MHz
UMTS 1900	Voice/Data	1852.4 - 1907.6 MHz
LTE Band 5 (Cell)	Voice/Data	824.7 - 848.3 MHz
2.4 GHz WLAN	Voice/Data	2412 - 2462 MHz
U-NII-1	Voice/Data	5180 - 5240 MHz
U-NII-2A	Voice/Data	5260 - 5320 MHz
U-NII-2C	Voice/Data	5500 - 5720 MHz
U-NII-3	Voice/Data	5745 - 5825 MHz
Bluetooth	Data	2402 - 2480 MHz
NFC	Data	13.56 MHz
ANT+	Data	2402 - 2480 MHz

## 1.2 Power Reduction for SAR

This device utilizes a single step power reduction mechanism for SAR compliance under portable hotspot conditions for some wireless modes and bands. All hotspot SAR evaluations for this device were performed at the maximum allowed output power when hotspot is enabled. Detailed descriptions of the power reduction mechanism are included in the operational description.



This device uses an independent fixed level power reduction mechanism for WLAN operations during voice or VoIP held to ear scenarios. Per FCC Guidance, the held-to-ear exposure conditions were evaluated at reduced power according to the head SAR positions described in IEEE 1528-2013. Detailed descriptions of the power reduction mechanism are included in the operational description.

## 1.3 Nominal and Maximum Output Power Specifications

This device operates using the following maximum and nominal output power specifications. SAR values were scaled to the maximum allowed power to determine compliance per KDB Publication 447498 D01v06.

### 1.3.1 Maximum Output Powers

Mode / Band		Voice (dBm)	Burst Average GMSK (dBm)				Burst Average 8-PSK (dBm)			
		1 TX Slot	1 TX Slots	2 TX Slots	3 TX Slots	4 TX Slots	1 TX Slots	2 TX Slots	3 TX Slots	4 TX Slots
GSM/GPRS/EDGE 850	Maximum	33.5	33.5	32.0	30.5	29.0	28.0	26.0	24.5	23.0
	Nominal	33.0	33.0	31.5	30.0	28.5	27.5	25.5	24.0	22.5
GSM/GPRS/EDGE 1900	Maximum	30.5	30.5	28.0	26.0	25.0	26.0	24.5	23.0	21.5
	Nominal	30.0	30.0	27.5	25.5	24.5	25.5	24.0	22.5	21.0

FCC ID: A3LSMJ530F		<b>SAR EVALUATION REPORT</b>		Approved by: Quality Manager
Document S/N: 1M1703200117-01.A3L	Test Dates: 03/20/17 - 04/05/17	DUT Type: Portable Handset	Page 3 of 49	

Mode / Band		Modulated Average (dBm)			
		3GPP WCDMA	3GPP HSDPA	3GPP HSUPA	3GPP DC-HSDPA
UMTS Band 5 (850 MHz)	Maximum	<b>23.8</b>	<b>23.0</b>	<b>23.0</b>	<b>23.0</b>
	Nominal	<b>23.3</b>	<b>22.5</b>	<b>22.5</b>	<b>22.5</b>
UMTS Band 4 (1750 MHz)	Maximum	<b>23.5</b>	<b>23.0</b>	<b>23.0</b>	<b>23.0</b>
	Nominal	<b>23.0</b>	<b>22.5</b>	<b>22.5</b>	<b>22.5</b>
UMTS Band 2 (1900 MHz)	Maximum	<b>23.0</b>	<b>23.0</b>	<b>23.0</b>	<b>23.0</b>
	Nominal	<b>22.5</b>	<b>22.5</b>	<b>22.5</b>	<b>22.5</b>



Mode / Band		Modulated Average (dBm)
LTE Band 5 (Cell)	Maximum	<b>25.0</b>
	Nominal	<b>24.5</b>

Mode / Band		Modulated Average (dBm)
IEEE 802.11b (2.4 GHz)	Maximum	<b>18.5</b>
	Nominal	<b>18.0</b>
IEEE 802.11g (2.4 GHz)	Maximum	<b>15.5</b>
	Nominal	<b>15.0</b>
IEEE 802.11n (2.4 GHz)	Maximum	<b>14.5</b>
	Nominal	<b>14.0</b>
Bluetooth	Maximum	<b>9.5</b>
	Nominal	<b>9.0</b>
Bluetooth LE	Maximum	<b>4.5</b>
	Nominal	<b>4.0</b>

Mode / Band		Modulated Average (dBm)		
		20 MHz Bandwidth	40 MHz Bandwidth	80 MHz Bandwidth
IEEE 802.11a (5 GHz)	Maximum	<b>14.5</b>		
	Nominal	<b>14.0</b>		
IEEE 802.11n (5 GHz)	Maximum	<b>13.5</b>	<b>12.5</b>	
	Nominal	<b>13.0</b>	<b>12.0</b>	
IEEE 802.11ac (5 GHz)	Maximum	<b>13.5</b>	<b>12.5</b>	<b>11.5</b>
	Nominal	<b>13.0</b>	<b>12.0</b>	<b>11.0</b>

### 1.3.2 Reduced Output Powers

Mode / Band		Burst Average GMSK (dBm)				Burst Average 8-PSK (dBm)			
		1 TX Slots	2 TX Slots	3 TX Slots	4 TX Slots	1 TX Slots	2 TX Slots	3 TX Slots	4 TX Slots
GSM/GPRS/EDGE 850	Maximum	<b>31.5</b>	<b>30.0</b>	<b>28.5</b>	<b>27.0</b>	<b>28.0</b>	<b>26.0</b>	<b>24.5</b>	<b>23.0</b>
	Nominal	<b>31.0</b>	<b>29.5</b>	<b>28.0</b>	<b>26.5</b>	<b>27.5</b>	<b>25.5</b>	<b>24.0</b>	<b>22.5</b>
GSM/GPRS/EDGE 1900	Maximum	<b>28.5</b>	<b>26.0</b>	<b>24.0</b>	<b>23.0</b>	<b>26.0</b>	<b>24.5</b>	<b>23.0</b>	<b>21.5</b>
	Nominal	<b>28.0</b>	<b>25.5</b>	<b>23.5</b>	<b>22.5</b>	<b>25.5</b>	<b>24.0</b>	<b>22.5</b>	<b>21.0</b>

FCC ID: A3LSMJ530F		<b>SAR EVALUATION REPORT</b>		Approved by: Quality Manager
Document S/N: 1M1703200117-01.A3L	Test Dates: 03/20/17 - 04/05/17	DUT Type: Portable Handset		Page 4 of 49

Mode / Band		Modulated Average (dBm)			
		3GPP WCDMA	3GPP HSDPA	3GPP HSUPA	3GPP DC-HSDPA
UMTS Band 4 (1750 MHz)	Maximum	19.5	19.5	19.5	19.5
	Nominal	19.0	19.0	19.0	19.0
UMTS Band 2 (1900 MHz)	Maximum	20.5	20.5	20.5	20.5
	Nominal	20.0	20.0	20.0	20.0

Mode / Band		Modulated Average (dBm)
IEEE 802.11b (2.4 GHz)	Maximum	16.5
	Nominal	16.0
IEEE 802.11g (2.4 GHz)	Maximum	13.5
	Nominal	13.0
IEEE 802.11n (2.4 GHz)	Maximum	12.5
	Nominal	12.0

Mode / Band		Modulated Average (dBm)		
		20 MHz Bandwidth	40 MHz Bandwidth	80 MHz Bandwidth
IEEE 802.11a (5 GHz)	Maximum	12.5		
	Nominal	12.0		
IEEE 802.11n (5 GHz)	Maximum	11.5	10.5	
	Nominal	11.0	10.0	
IEEE 802.11ac (5 GHz)	Maximum	11.5	10.5	9.5
	Nominal	11.0	10.0	9.0



## 1.4 DUT Antenna Locations

The overall dimensions of this device are > 9 x 5 cm. The overall diagonal dimension of the device is ≤160 mm and the diagonal display is ≤150 mm. A diagram showing the location of the device antennas can be found in Appendix F.

**Table 1-1  
Device Edges/Sides for SAR Testing**

Mode	Back	Front	Top	Bottom	Right	Left
GPRS 850	Yes	Yes	No	Yes	Yes	Yes
GPRS 1900	Yes	Yes	No	Yes	Yes	Yes
UMTS 850	Yes	Yes	No	Yes	Yes	Yes
UMTS 1750	Yes	Yes	No	Yes	Yes	Yes
UMTS 1900	Yes	Yes	No	Yes	Yes	Yes
LTE Band 5 (Cell)	Yes	Yes	No	Yes	Yes	Yes
2.4 GHz WLAN	Yes	Yes	Yes	No	Yes	Yes
5 GHz WLAN	Yes	Yes	Yes	No	Yes	Yes

Note: Particular DUT edges were not required to be evaluated for wireless router SAR if the edges were greater than 2.5 cm from the transmitting antenna according to FCC KDB Publication 941225 D06v02r01 Section III. The distances between the transmit antennas and the edges of the device are included in the filing. When wireless router mode is enabled, U-NII-1, U-NII-2A, U-NII-2C operations are disabled. Therefore, U-NII-1, U-NII-2A, U-NII-2C operations are not considered in this section.

FCC ID: A3LSMJ530F		<b>SAR EVALUATION REPORT</b>		Approved by: Quality Manager
Document S/N: 1M1703200117-01.A3L	Test Dates: 03/20/17 - 04/05/17	DUT Type: Portable Handset		Page 5 of 49

## 1.5 Near Field Communications (NFC) Antenna

This DUT has NFC operations. The NFC antenna is integrated into the device for this model. Therefore, all SAR tests were performed with the device which already incorporates the NFC antenna. A diagram showing the location of the NFC antenna can be found in Appendix F.

## 1.6 Simultaneous Transmission Capabilities

According to FCC KDB Publication 447498 D01v06, transmitters are considered to be transmitting simultaneously when there is overlapping transmission, with the exception of transmissions during network hand-offs with maximum hand-off duration less than 30 seconds. Possible transmission paths for the DUT are shown in Figure 1-1 and are color-coded to indicate communication modes which share the same path. Modes which share the same transmission path cannot transmit simultaneously with one another.



Figure 1-1  
Simultaneous Transmission Paths

This device contains multiple transmitters that may operate simultaneously, and therefore requires a simultaneous transmission analysis according to FCC KDB Publication 447498 D01v06 4.3.2 procedures.

Table 1-2  
Simultaneous Transmission Scenarios

No.	Capable Transmit Configuration	Head	Body-Worn Accessory	Wireless Router
1	GSM voice + 2.4 GHz WI-FI	Yes	Yes	N/A
2	GSM voice + 5 GHz WI-FI	Yes	Yes	N/A
3	GSM voice + 2.4 GHz Bluetooth	N/A	Yes	N/A
4	UMTS + 2.4 GHz WI-FI	Yes	Yes	Yes
5	UMTS + 5 GHz WI-FI	Yes	Yes	Yes
6	UMTS + 2.4 GHz Bluetooth	N/A	Yes	N/A
7	LTE + 2.4 GHz WI-FI	Yes	Yes	Yes
8	LTE + 5 GHz WI-FI	Yes	Yes	Yes
9	LTE + 2.4 GHz Bluetooth	N/A	Yes	N/A
10	GPRS/EDGE + 2.4 GHz WI-FI	N/A	N/A	Yes
11	GPRS/EDGE + 5 GHz WI-FI	N/A	N/A	Yes
12	GPRS/EDGE + 2.4 GHz Bluetooth	N/A	N/A	N/A

- 2.4 GHz WLAN, 5 GHz WLAN, and 2.4 GHz Bluetooth share the same antenna path and cannot transmit simultaneously.
- All licensed modes share the same antenna path and cannot transmit simultaneously.
- When the user utilizes multiple services in UMTS 3G mode it uses multi-Radio Access Bearer or multi-RAB. The power control is based on a physical control channel (Dedicated Physical Control Channel [DPCCH]) and power control will be adjusted to meet the needs of both services. Therefore, the UMTS+WLAN scenario also represents the UMTS Voice/DATA + WLAN Hotspot scenario.
- Per the manufacturer, WIFI Direct is not expected to be used in conjunction with a held-to-ear or body-worn accessory voice call. Therefore, there are no simultaneous transmission scenarios involving WIFI direct beyond that listed in the above table.
- 5 GHz Wireless Router is only supported for the U-NII-3 by S/W, therefore U-NII-1, U-NII2A, and U-NII2C were not evaluated for wireless router conditions.
- This device supports VOLTE and VOWIFI.

FCC ID: A3LSMJ530F		SAR EVALUATION REPORT		Approved by: Quality Manager
Document S/N: 1M1703200117-01.A3L	Test Dates: 03/20/17 - 04/05/17	DUT Type: Portable Handset		Page 6 of 49

## 1.7 Miscellaneous SAR Test Considerations

### (A) WIFI/BT

Since U-NII-1 and U-NII-2A bands have the same maximum output power and the highest reported SAR for U-NII-2A is less than 1.2 W/kg, SAR is not required for U-NII-1 band according to FCC KDB Publication 248227 D01v02r02.

Since Wireless Router operations are not allowed by the chipset firmware using U-NII-1, U-NII-2A & U-NII-2C WIFI, only 2.4 GHz and U-NII-3 WIFI Hotspot SAR tests and combinations are considered for SAR with respect to Wireless Router configurations according to FCC KDB 941225 D06v02r01.

Per FCC KDB 447498 D01v06, the 1g SAR exclusion threshold for distances <50mm is defined by the following equation:

$$\frac{\text{Max Power of Channel (mW)}}{\text{Test Separation Dist (mm)}} * \sqrt{\text{Frequency(GHz)}} \leq 3.0$$

Based on the maximum conducted power of Bluetooth (rounded to the nearest mW) and the antenna to user separation distance, body-worn Bluetooth SAR was not required;  $[(9/15) * \sqrt{2.480}] = 0.9 < 3.0$ . Per KDB Publication 447498 D01v06, the maximum power of the channel was rounded to the nearest mW before calculation.

This device supports IEEE 802.11ac with the following features:



- a) Up to 80 MHz Bandwidth only
- b) No aggregate channel configurations
- c) 1 Tx antenna output
- d) 256 QAM is supported
- e) TDWR and Band gap channels are supported

### (B) Licensed Transmitter(s)

GSM/GPRS/EDGE DTM is not supported for US bands. Therefore, the GSM Voice modes in this report do not transmit simultaneously with GPRS/EDGE Data.

This device is only capable of QPSK HSUPA in the uplink. Therefore, no additional SAR tests are required beyond that described for devices with HSUPA in KDB 941225 D01v03r01.

LTE SAR for the higher modulations and lower bandwidths were not tested since the maximum average output power of all required channels and configurations was not more than 0.5 dB higher than the highest bandwidth; and the reported LTE SAR for the highest bandwidth was less than 1.45 W/kg for all configurations according to FCC KDB 941225 D05v02r04.

FCC ID: A3LSMJ530F		SAR EVALUATION REPORT		Approved by: Quality Manager
Document S/N: 1M1703200117-01.A3L	Test Dates: 03/20/17 - 04/05/17	DUT Type: Portable Handset		Page 7 of 49



## 1.8 Guidance Applied

- IEEE 1528-2013
- FCC KDB Publication 941225 D01v03r01, D05v02r04, D05Av01r02, D06v02r01 (2G/3G/4G and Hotspot)
- FCC KDB Publication 248227 D01v02r02 (SAR Considerations for 802.11 Devices)
- FCC KDB Publication 447498 D01v06 (General SAR Guidance)
- FCC KDB Publication 865664 D01v01r04, D02v01r02 (SAR Measurements up to 6 GHz)
- October 2013 TCB Workshop Notes (GPRS Testing Considerations)

## 1.9 Device Serial Numbers

Several samples with identical hardware were used to support SAR testing. The manufacturer has confirmed that the device(s) tested have the same physical, mechanical and thermal characteristics and are within operational tolerances expected for production units.



	Head Serial Number	Body-Worn Serial Number	Hotspot Serial Number
GSM/GPRS/EDGE 850	11456	29760	29760
GSM/GPRS/EDGE 1900	11456	29828	29828
UMTS 850	29760	29828	29828
UMTS 1750	12355	29828	29828
UMTS 1900	11456	29828	29828
LTE Band 5 (Cell)	11456	29828	29828
2.4 GHz WLAN	74852	29752	29752
5 GHz WLAN	19228	74902	74902

<b>FCC ID:</b> A3LSMJ530F		<b>SAR EVALUATION REPORT</b>		<b>Approved by:</b> Quality Manager
<b>Document S/N:</b> 1M1703200117-01.A3L	<b>Test Dates:</b> 03/20/17 - 04/05/17	<b>DUT Type:</b> Portable Handset	Page 8 of 49	

## 2

## LTE INFORMATION

LTE Information			
<b>FCC ID</b>	<b>A3LSMJ530F</b>		
Form Factor	Portable Handset		
Frequency Range of each LTE transmission band	LTE Band 5 (Cell) (824.7 - 848.3 MHz)		
Channel Bandwidths	LTE Band 5 (Cell): 1.4 MHz, 3 MHz, 5 MHz, 10 MHz		
Channel Numbers and Frequencies (MHz)	Low	Mid	High
LTE Band 5 (Cell): 1.4 MHz	824.7 (20407)	836.5 (20525)	848.3 (20643)
LTE Band 5 (Cell): 3 MHz	825.5 (20415)	836.5 (20525)	847.5 (20635)
LTE Band 5 (Cell): 5 MHz	826.5 (20425)	836.5 (20525)	846.5 (20625)
LTE Band 5 (Cell): 10 MHz	829 (20450)	836.5 (20525)	844 (20600)
UE Category	6		
Modulations Supported in UL	QPSK, 16QAM		
LTE MPR Permanently implemented per 3GPP TS 36.101 section 6.2.3~6.2.5? (manufacturer attestation to be provided)	YES		
A-MPR (Additional MPR) disabled for SAR Testing?	YES		
LTE Release 10 Additional Information	This device does not support full CA features on 3GPP Release 10. All uplink communications are identical to the Release 8 Specifications. The following LTE Release 10 Features are not supported: Carrier Aggregation, Relay, HetNet, Enhanced MIMO, eICIC, WIFI Offloading, MDH, eMBMS, Cross-Carrier Scheduling, Enhanced SC-FDMA.		

<b>FCC ID:</b> A3LSMJ530F		<b>SAR EVALUATION REPORT</b>		<b>Approved by:</b> Quality Manager
<b>Document S/N:</b> 1M1703200117-01.A3L	<b>Test Dates:</b> 03/20/17 - 04/05/17	<b>DUT Type:</b> Portable Handset	Page 9 of 49	

## 3 INTRODUCTION

The FCC and Innovation, Science, and Economic Development Canada have adopted the guidelines for evaluating the environmental effects of radio frequency (RF) radiation in ET Docket 93-62 on Aug. 6, 1996 and Health Canada Safety Code 6 to protect the public and workers from the potential hazards of RF emissions due to FCC-regulated portable devices. [1]

The safety limits used for the environmental evaluation measurements are based on the criteria published by the American National Standards Institute (ANSI) for localized specific absorption rate (SAR) in IEEE/ANSI C95.1-1992 Standard for Safety Levels with Respect to Human Exposure to Radio Frequency Electromagnetic Fields, 3 kHz to 300 GHz [3] and Health Canada RF Exposure Guidelines Safety Code 6 [22]. The measurement procedure described in IEEE/ANSI C95.3-2002 Recommended Practice for the Measurement of Potentially Hazardous Electromagnetic Fields - RF and Microwave [4] is used for guidance in measuring the Specific Absorption Rate (SAR) due to the RF radiation exposure from the Equipment Under Test (EUT). These criteria for SAR evaluation are similar to those recommended by the International Committee for Non-Ionizing Radiation Protection (ICNIRP) in Biological Effects and Exposure Criteria for Radiofrequency Electromagnetic Fields,” Report No. Vol 74. SAR is a measure of the rate of energy absorption due to exposure to an RF transmitting source. SAR values have been related to threshold levels for potential biological hazards.

### 3.1 SAR Definition

Specific Absorption Rate is defined as the time derivative (rate) of the incremental energy (dU) absorbed by (dissipated in) an incremental mass (dm) contained in a volume element (dV) of a given density ( $\rho$ ). It is also defined as the rate of RF energy absorption per unit mass at a point in an absorbing body (see Equation 3-1).

**Equation 3-1**  
**SAR Mathematical Equation**

$$SAR = \frac{d}{dt} \left( \frac{dU}{dm} \right) = \frac{d}{dt} \left( \frac{dU}{\rho dv} \right)$$



**SAR is expressed in units of Watts per Kilogram (W/kg).**

$$SAR = \frac{\sigma \cdot E^2}{\rho}$$

where:

- $\sigma$  = conductivity of the tissue-simulating material (S/m)
- $\rho$  = mass density of the tissue-simulating material ( $\text{kg/m}^3$ )
- E = Total RMS electric field strength (V/m)

NOTE: The primary factors that control rate of energy absorption were found to be the wavelength of the incident field in relation to the dimensions and geometry of the irradiated organism, the orientation of the organism in relation to the polarity of field vectors, the presence of reflecting surfaces, and whether conductive contact is made by the organism with a ground plane.[6]

<b>FCC ID:</b> A3LSMJ530F		<b>SAR EVALUATION REPORT</b>		<b>Approved by:</b> Quality Manager
<b>Document S/N:</b> 1M1703200117-01.A3L	<b>Test Dates:</b> 03/20/17 - 04/05/17	<b>DUT Type:</b> Portable Handset	Page 10 of 49	

## 4 DOSIMETRIC ASSESSMENT

### 4.1 Measurement Procedure

The evaluation was performed using the following procedure compliant to FCC KDB Publication 865664 D01v01r04 and IEEE 1528-2013:

1. The SAR distribution at the exposed side of the head or body was measured at a distance no greater than 5.0 mm from the inner surface of the shell. The area covered the entire dimension of the device-head and body interface and the horizontal grid resolution was determined per FCC KDB Publication 865664 D01v01r04 (See Table 4-1) and IEEE 1528-2013.
2. The point SAR measurement was taken at the maximum SAR region determined from Step 1 to enable the monitoring of SAR fluctuations/drifts during the 1g/10g cube evaluation. SAR at this fixed point was measured and used as a reference value.
3. Based on the area scan data, the peak of the region with maximum SAR was determined by spline interpolation. Around this point, a volume was assessed according to the measurement resolution and volume size requirements of FCC KDB Publication 865664 D01v01r04 (See Table 4-1) and IEEE 1528-2013. On the basis of this data set, the spatial peak SAR value was evaluated with the following procedure (see references or the DASY manual online for more details):
  - a. SAR values at the inner surface of the phantom are extrapolated from the measured values along the line away from the surface with spacing no greater than that in Table 4-1. The extrapolation was based on a least-squares algorithm. A polynomial of the fourth order was calculated through the points in the z-axis (normal to the phantom shell).
  - b. After the maximum interpolated values were calculated between the points in the cube, the SAR was averaged over the spatial volume (1g or 10g) using a 3D-Spline interpolation algorithm. The 3D-spline is composed of three one-dimensional splines with the “Not a knot” condition (in x, y, and z directions). The volume was then integrated with the trapezoidal algorithm. One thousand points (10 x 10 x 10) were obtained through interpolation, in order to calculate the averaged SAR.
  - c. All neighboring volumes were evaluated until no neighboring volume with a higher average value was found.
4. The SAR reference value, at the same location as step 2, was re-measured after the zoom scan was complete to calculate the SAR drift. If the drift deviated by more than 5%, the SAR test and drift measurements were repeated.

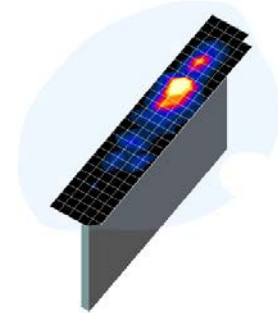



**Figure 4-1**  
Sample SAR Area Scan

**Table 4-1**  
Area and Zoom Scan Resolutions per FCC KDB Publication 865664 D01v01r04\*

Frequency	Maximum Area Scan Resolution (mm) ( $\Delta x_{\text{area}}, \Delta y_{\text{area}}$ )	Maximum Zoom Scan Resolution (mm) ( $\Delta x_{\text{zoom}}, \Delta y_{\text{zoom}}$ )	Maximum Zoom Scan Spatial Resolution (mm)			Minimum Zoom Scan Volume (mm) (x,y,z)
			Uniform Grid	Graded Grid		
			$\Delta z_{\text{zoom}}(n)$	$\Delta z_{\text{zoom}}(1)^*$	$\Delta z_{\text{zoom}}(n-1)^*$	
≤ 2 GHz	≤ 15	≤ 8	≤ 5	≤ 4	≤ 1.5* $\Delta z_{\text{zoom}}(n-1)$	≥ 30
2-3 GHz	≤ 12	≤ 5	≤ 5	≤ 4	≤ 1.5* $\Delta z_{\text{zoom}}(n-1)$	≥ 30
3-4 GHz	≤ 12	≤ 5	≤ 4	≤ 3	≤ 1.5* $\Delta z_{\text{zoom}}(n-1)$	≥ 28
4-5 GHz	≤ 10	≤ 4	≤ 3	≤ 2.5	≤ 1.5* $\Delta z_{\text{zoom}}(n-1)$	≥ 25
5-6 GHz	≤ 10	≤ 4	≤ 2	≤ 2	≤ 1.5* $\Delta z_{\text{zoom}}(n-1)$	≥ 22

\*Also compliant to IEEE 1528-2013 Table 6

<b>FCC ID:</b> A3LSMJ530F		<b>SAR EVALUATION REPORT</b>		<b>Approved by:</b> Quality Manager
<b>Document S/N:</b> 1M1703200117-01.A3L	<b>Test Dates:</b> 03/20/17 - 04/05/17	<b>DUT Type:</b> Portable Handset	Page 11 of 49	

## 5 DEFINITION OF REFERENCE POINTS

### 5.1 EAR REFERENCE POINT

Figure 5-2 shows the front, back and side views of the SAM Twin Phantom. The point “M” is the reference point for the center of the mouth, “LE” is the left ear reference point (ERP), and “RE” is the right ERP. The ERP is 15mm posterior to the entrance to the ear canal (EEC) along the B-M line (Back-Mouth), as shown in Figure 5-1. The plane passing through the two ear canals and M is defined as the Reference Plane. The line N-F (Neck-Front), also called the Reference Pivoting Line, is not perpendicular to the reference plane (see Figure 5-1). Line B-M is perpendicular to the N-F line. Both N-F and B-M lines are marked on the external phantom shell to facilitate handset positioning [5].

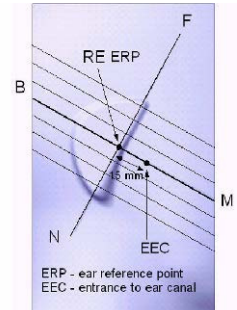

**Figure 5-1**  
Close-Up Side view of ERP

### 5.2 HANDSET REFERENCE POINTS



Two imaginary lines on the handset were established: the vertical centerline and the horizontal line. The test device was placed in a normal operating position with the acoustic output located along the “vertical centerline” on the front of the device aligned to the “ear reference point” (See Figure 5-3). The acoustic output was then located at the same level as the center of the ear reference point. The test device was positioned so that the “vertical centerline” was bisecting the front surface of the handset at its top and bottom edges, positioning the “ear reference point” on the outer surface of the both the left and right head phantoms on the ear reference point.

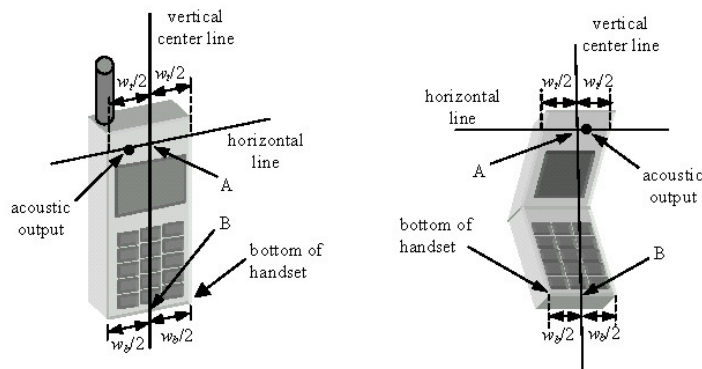

**Figure 5-2**  
Front, back and side view of SAM Twin Phantom



**Figure 5-3**  
Handset Vertical Center & Horizontal Line Reference Points

FCC ID: A3LSMJ530F		SAR EVALUATION REPORT		Approved by: Quality Manager
Document S/N: 1M1703200117-01.A3L	Test Dates: 03/20/17 - 04/05/17	DUT Type: Portable Handset		Page 12 of 49

## 6 TEST CONFIGURATION POSITIONS

### 6.1 Device Holder

The device holder is made out of low-loss POM material having the following dielectric parameters: relative permittivity  $\epsilon = 3$  and loss tangent  $\delta = 0.02$ .

### 6.2 Positioning for Cheek

1. The test device was positioned with the device close to the surface of the phantom such that point A is on the (virtual) extension of the line passing through points RE and LE on the phantom (see Figure 6-1), such that the plane defined by the vertical center line and the horizontal line of the phone is approximately parallel to the sagittal plane of the phantom.

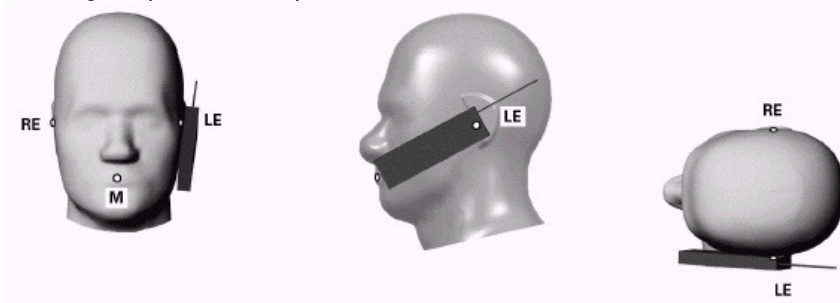



Figure 6-1 Front, Side and Top View of Cheek Position

2. The handset was translated towards the phantom along the line passing through RE & LE until the handset touches the pinna.
3. While maintaining the handset in this plane, the handset was rotated around the LE-RE line until the vertical centerline was in the reference plane.
4. The phone was then rotated around the vertical centerline until the phone (horizontal line) was symmetrical with respect to the line NF.
5. While maintaining the vertical centerline in the reference plane, keeping point A on the line passing through RE and LE, and maintaining the device contact with the ear, the device was rotated about the NF line until any point on the handset made contact with a phantom point below the ear (cheek) (See Figure 6-2).

### 6.3 Positioning for Ear / 15° Tilt

With the test device aligned in the “Cheek Position”:

1. While maintaining the orientation of the phone, the phone was retracted parallel to the reference plane far enough to enable a rotation of the phone by 15 degrees.
2. The phone was then rotated around the horizontal line by 15 degrees.
3. While maintaining the orientation of the phone, the phone was moved parallel to the reference plane until any part of the handset touched the head. (In this position, point A was located on the line RE-LE). The tilted position is obtained when the contact is on the pinna. If the contact was at any location other than the pinna, the angle of the phone would then be reduced. In this situation, the tilted position was obtained when any part of the phone was in contact of the ear as well as a second part of the phone was in contact with the head (see Figure 6-2).

FCC ID: A3LSMJ530F		SAR EVALUATION REPORT		Approved by: Quality Manager
Document S/N: 1M1703200117-01.A3L	Test Dates: 03/20/17 - 04/05/17	DUT Type: Portable Handset		Page 13 of 49

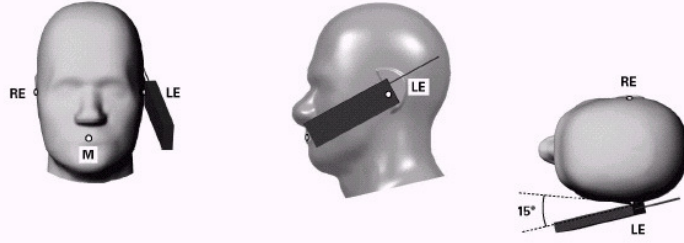

**Figure 6-2 Front, Side and Top View of Ear/15° Tilt Position**

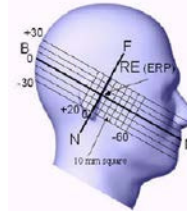

**Figure 6-3 Side view w/ relevant markings**

## 6.4 SAR Evaluations near the Mouth/Jaw Regions of the SAM Phantom

Antennas located near the bottom of a phone may require SAR measurements around the mouth and jaw regions of the SAM head phantom. This typically applies to clam-shell style phones that are generally longer in the unfolded normal use positions or to certain older style long rectangular phones. Per IEEE 1528-2013, a rotated SAM phantom is necessary to allow probe access to such regions. Both SAM heads of the TwinSAM-Chin20 are rotated 20 degrees around the NF line. Each head can be removed from the table for emptying and cleaning.

Under these circumstances, the following procedures apply, adopted from the FCC guidance on SAR handsets document FCC KDB Publication 648474 D04v01r03. The SAR required in these regions of SAM should be measured using a flat phantom. The phone should be positioned with a separation distance of 4 mm between the ear reference point (ERP) and the outer surface of the flat phantom shell. While maintaining this distance at the ERP location, the low (bottom) edge of the phone should be lowered from the phantom to establish the same separation distance between the peak SAR location identified by the truncated partial SAR distribution measured with the SAM phantom. The distance from the peak SAR location to the phone is determined by the straight line passing perpendicularly through the phantom surface. When it is not feasible to maintain 4 mm separation at the ERP while also establishing the required separation at the peak SAR location, the top edge of the phone will be allowed to touch the phantom with a separation < 4 mm at the ERP. The phone should not be tilted to the left or right while placed in this inclined position to the flat phantom.

## 6.5 Body-Worn Accessory Configurations

Body-worn operating configurations are tested with the belt-clips and holsters attached to the device and positioned against a flat phantom in a normal use configuration (see Figure 6-4). Per FCC KDB Publication 648474 D04v01r03, Body-worn accessory exposure is typically related to voice mode operations when handsets are carried in body-worn accessories. The body-worn accessory procedures in FCC KDB Publication 447498 D01v06 should be used to test for body-worn accessory SAR compliance, without a headset connected to it. This enables the test results for such configuration to be compatible with that required for hotspot mode when the body-worn accessory test separation distance is greater than or equal to that required for hotspot mode, when applicable. When the reported SAR for a body-worn accessory, measured without a headset connected to the handset, is > 1.2 W/kg, the highest reported SAR configuration for that wireless mode and frequency band should be repeated for that body-worn accessory with a headset attached to the handset.

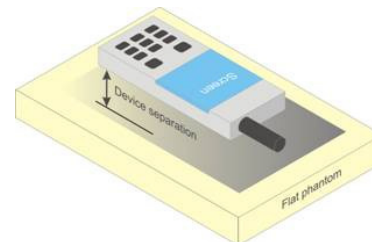

**Figure 6-4 Sample Body-Worn Diagram**

Accessories for Body-worn operation configurations are divided into two categories: those that do not contain metallic components and those that do contain metallic components. When multiple accessories that do not contain metallic components are supplied with the device, the device is tested with only the accessory that

FCC ID: A3LSMJ530F		SAR EVALUATION REPORT		Approved by: Quality Manager
Document S/N: 1M1703200117-01.A3L	Test Dates: 03/20/17 - 04/05/17	DUT Type: Portable Handset		Page 14 of 49

dictates the closest spacing to the body. Then multiple accessories that contain metallic components are tested with the device with each accessory. If multiple accessories share an identical metallic component (i.e. the same metallic belt-clip used with different holsters with no other metallic components) only the accessory that dictates the closest spacing to the body is tested.

Body-worn accessories may not always be supplied or available as options for some devices intended to be authorized for body-worn use. In this case, a test configuration with a separation distance between the back of the device and the flat phantom is used. Test position spacing was documented. Transmitters that are designed to operate in front of a person's face, as in push-to-talk configurations, are tested for SAR compliance with the front of the device positioned to face the flat phantom in head fluid. For devices that are carried next to the body such as a shoulder, waist or chest-worn transmitters, SAR compliance is tested with the accessories, including headsets and microphones, attached to the device and positioned against a flat phantom in a normal use configuration.

## 6.6 Extremity Exposure Configurations



Devices that are designed or intended for use on extremities or mainly operated in extremity only exposure conditions; i.e., hands, wrists, feet and ankles, may require extremity SAR evaluation. When the device also operates in close proximity to the user's body, SAR compliance for the body is also required. The 1-g body and 10-g extremity SAR Exclusion Thresholds found in KDB Publication 447498 D01v06 should be applied to determine SAR test requirements.

Per KDB Publication 447498 D01v06, Cell phones (handsets) are not normally designed to be used on extremities or operated in extremity only exposure conditions. The maximum output power levels of handsets generally do not require extremity SAR testing to show compliance. Therefore, extremity SAR was not evaluated for this device.

## 6.7 Wireless Router Configurations

Some battery-operated handsets have the capability to transmit and receive user data through simultaneous transmission of WIFI simultaneously with a separate licensed transmitter. The FCC has provided guidance in FCC KDB Publication 941225 D06v02r01 where SAR test considerations for handsets ( $L \times W \geq 9 \text{ cm} \times 5 \text{ cm}$ ) are based on a composite test separation distance of 10 mm from the front, back and edges of the device containing transmitting antennas within 2.5 cm of their edges, determined from general mixed use conditions for this type of devices. Since the hotspot SAR results may overlap with the body-worn accessory SAR requirements, the more conservative configurations can be considered, thus excluding some body-worn accessory SAR tests.

When the user enables the personal wireless router functions for the handset, actual operations include simultaneous transmission of both the WIFI transmitter and another licensed transmitter. Both transmitters often do not transmit at the same transmitting frequency and thus cannot be evaluated for SAR under actual use conditions due to the limitations of the SAR assessment probes. Therefore, SAR must be evaluated for each frequency transmission and mode separately and spatially summed with the WIFI transmitter according to FCC KDB Publication 447498 D01v06 procedures. The "Portable Hotspot" feature on the handset was NOT activated during SAR assessments, to ensure the SAR measurements were evaluated for a single transmission frequency RF signal at a time.

<b>FCC ID:</b> A3LSMJ530F		<b>SAR EVALUATION REPORT</b>		<b>Approved by:</b> Quality Manager
<b>Document S/N:</b> 1M1703200117-01.A3L	<b>Test Dates:</b> 03/20/17 - 04/05/17	<b>DUT Type:</b> Portable Handset	Page 15 of 49	

# 7 RF EXPOSURE LIMITS

## 7.1 Uncontrolled Environment

UNCONTROLLED ENVIRONMENTS are defined as locations where there is the exposure of individuals who have no knowledge or control of their exposure. The general population/uncontrolled exposure limits are applicable to situations in which the general public may be exposed or in which persons who are exposed as a consequence of their employment may not be made fully aware of the potential for exposure or cannot exercise control over their exposure. Members of the general public would come under this category when exposure is not employment-related; for example, in the case of a wireless transmitter that exposes persons in its vicinity.



## 7.2 Controlled Environment

CONTROLLED ENVIRONMENTS are defined as locations where there is exposure that may be incurred by persons who are aware of the potential for exposure, (i.e. as a result of employment or occupation). In general, occupational/controlled exposure limits are applicable to situations in which persons are exposed as a consequence of their employment, who have been made fully aware of the potential for exposure and can exercise control over their exposure. This exposure category is also applicable when the exposure is of a transient nature due to incidental passage through a location where the exposure levels may be higher than the general population/uncontrolled limits, but the exposed person is fully aware of the potential for exposure and can exercise control over his or her exposure by leaving the area or by some other appropriate means.

**Table 7-1  
SAR Human Exposure Specified in ANSI/IEEE C95.1-1992 and Health Canada Safety Code 6**

HUMAN EXPOSURE LIMITS		
	UNCONTROLLED ENVIRONMENT <i>General Population</i> (W/kg) or (mW/g)	CONTROLLED ENVIRONMENT <i>Occupational</i> (W/kg) or (mW/g)
<b>Peak Spatial Average SAR</b> Head	1.6	8.0
<b>Whole Body SAR</b>	0.08	0.4
<b>Peak Spatial Average SAR</b> Hands, Feet, Ankle, Wrists, etc.	4.0	20

1. The Spatial Peak value of the SAR averaged over any 1 gram of tissue (defined as a tissue volume in the shape of a cube) and over the appropriate averaging time.
2. The Spatial Average value of the SAR averaged over the whole body.
3. The Spatial Peak value of the SAR averaged over any 10 grams of tissue (defined as a tissue volume in the shape of a cube) and over the appropriate averaging time.

<b>FCC ID:</b> A3LSMJ530F		<b>SAR EVALUATION REPORT</b>		<b>Approved by:</b> Quality Manager
<b>Document S/N:</b> 1M1703200117-01.A3L	<b>Test Dates:</b> 03/20/17 - 04/05/17	<b>DUT Type:</b> Portable Handset	Page 16 of 49	

## 8 FCC MEASUREMENT PROCEDURES

Power measurements for licensed transmitters are performed using a base station simulator under digital average power.

### 8.1 Measured and Reported SAR

Per FCC KDB Publication 447498 D01v06, when SAR is not measured at the maximum power level allowed for production units, the results must be scaled to the maximum tune-up tolerance limit according to the power applied to the individual channels tested to determine compliance. For simultaneous transmission, the measured aggregate SAR must be scaled according to the sum of the differences between the maximum tune-up tolerance and actual power used to test each transmitter. When SAR is measured at or scaled to the maximum tune-up tolerance limit, the results are referred to as *reported* SAR. The highest *reported* SAR results are identified on the grant of equipment authorization according to procedures in KDB 690783 D01v01r03.

### 8.2 3G SAR Test Reduction Procedure

In FCC KDB Publication 941225 D01v03r01, certain transmission modes within a frequency band and wireless mode evaluated for SAR are defined as primary modes. The equivalent modes considered for SAR test reduction are denoted as secondary modes. When the maximum output power including tune-up tolerance specified for production units in a secondary mode is  $\leq 0.25$  dB higher than the primary mode or when the highest reported SAR of the primary mode, scaled by the ratio of specified maximum output power and tune-up tolerance of secondary to primary mode, is  $\leq 1.2$  W/kg, SAR measurements are not required for the secondary mode. These criteria are referred to as the 3G SAR test reduction procedure. When the 3G SAR test reduction procedure is not satisfied, SAR measurements are additionally required for the secondary mode.

### 8.3 Procedures Used to Establish RF Signal for SAR



The following procedures are according to FCC KDB Publication 941225 D01v03r01 “3G SAR Measurement Procedures.”

The device is placed into a simulated call using a base station simulator in a RF shielded chamber. Establishing connections in this manner ensure a consistent means for testing SAR and are recommended for evaluating SAR [4]. Devices under test are evaluated prior to testing, with a fully charged battery and were configured to operate at maximum output power. In order to verify that the device is tested throughout the SAR test at maximum output power, the SAR measurement system measures a “point SAR” at an arbitrary reference point at the start and end of the 1 gram SAR evaluation, to assess for any power drifts during the evaluation. If the power drift deviates by more than 5%, the SAR test and drift measurements are repeated.

### 8.4 SAR Measurement Conditions for UMTS

#### 8.4.1 Output Power Verification

Maximum output power is verified on the High, Middle and Low channels according to the general descriptions in section 5.2 of 3GPP TS 34.121, using the appropriate RMC with TPC (transmit power control) set to all “1s” or applying the required inner loop power control procedures to maintain maximum output power while HSUPA is active. Results for all applicable physical channel configurations (DPCCH, DPDCHn and spreading codes, HS-DPCCH etc) are tabulated in this test report. All configurations that are not supported by the DUT or cannot be measured due to technical or equipment limitations are identified.

FCC ID: A3LSMJ530F		SAR EVALUATION REPORT		Approved by: Quality Manager
Document S/N: 1M1703200117-01.A3L	Test Dates: 03/20/17 - 04/05/17	DUT Type: Portable Handset	Page 17 of 49	

## 8.4.2 Head SAR Measurements

SAR for next to the ear head exposure is measured using a 12.2 kbps RMC with TPC bits configured to all “1’s”. The 3G SAR test reduction procedure is applied to AMR configurations with 12.2 kbps RMC as the primary mode. Otherwise, SAR is measured for 12.2 kbps AMR in 3.4 kbps SRB (signaling radio bearer) using the highest reported SAR configuration in 12.2 kbps RMC for head exposure.

## 8.4.3 Body SAR Measurements

SAR for body exposure configurations is measured using the 12.2 kbps RMC with the TPC bits all “1s”. The 3G SAR test reduction procedure is applied to other spreading codes and multiple DPDCH<sub>n</sub> configurations supported by the handset with 12.2 kbps RMC as the primary mode. Otherwise, SAR is measured using an applicable RMC configuration with the corresponding spreading code or DPDCH<sub>n</sub>, for the highest reported SAR configuration in 12.2 kbps RMC.

## 8.4.4 SAR Measurements with Rel 5 HSDPA

The 3G SAR test reduction procedure is applied to HSDPA body configurations with 12.2 kbps RMC as the primary mode. Otherwise, Body SAR for HSDPA is measured using an FRC with H-Set 1 in Sub-test 1 and a 12.2 kbps RMC configured in Test Loop Mode 1, for the highest reported SAR configuration in 12.2 kbps RMC without HSDPA. Handsets with both HSDPA and HSUPA are tested according to Release 6 HSPA test procedures.

## 8.4.5 SAR Measurements with Rel 6 HSUPA

The 3G SAR test reduction procedure is applied to HSPA (HSUPA/HSDPA with RMC) body configurations with 12.2 kbps RMC as the primary mode. Otherwise, Body SAR for HSPA is measured with E-DCH Sub-test 5, using H-Set 1 and QPSK for FRC and a 12.2 kbps RMC configured in Test Loop Mode 1 and power control algorithm 2, according to the highest reported body SAR configuration in 12.2 kbps RMC without HSPA.

When VOIP applies to head exposure, the 3G SAR test reduction procedure is applied with 12.2 kbps RMC as the primary mode; otherwise, the same HSPA configuration used for body SAR measurements are applied to head exposure testing.

## 8.4.6 SAR Measurement Conditions for DC-HSDPA



SAR is required for Rel. 8 DC-HSDPA when SAR is required for Rel. 5 HSDPA; otherwise, the 3G SAR test reduction procedure is applied to DC-HSDPA with 12.2 kbps RMC as the primary mode. Power is measured for DC-HSDPA according to the H-Set 12, FRC configuration in Table C.8.1.12 of 3GPP TS 34.121-1 to determine SAR test reduction. A primary and a secondary serving HS-DSCH Cell are required to perform the power measurement and for the results to be acceptable.

## 8.5 SAR Measurement Conditions for LTE

LTE modes are tested according to FCC KDB 941225 D05v02r04 publication. Establishing connections with base station simulators ensure a consistent means for testing SAR and are recommended for evaluating SAR [4]. The R&S CMW500 or Anritsu MT8820C simulators are used for LTE output power measurements and SAR testing. Closed loop power control was used so the UE transmits with maximum output power during SAR testing. SAR tests were performed with the same number of RB and RB offsets transmitting on all TTI frames (maximum TTI).

### 8.5.1 Spectrum Plots for RB Configurations

A properly configured base station simulator was used for SAR tests and power measurements. Therefore, spectrum plots for RB configurations were not required to be included in this report.

FCC ID: A3LSMJ530F		SAR EVALUATION REPORT		Approved by: Quality Manager
Document S/N: 1M1703200117-01.A3L	Test Dates: 03/20/17 - 04/05/17	DUT Type: Portable Handset		Page 18 of 49

## 8.5.2 MPR

MPR is permanently implemented for this device by the manufacturer. The specific manufacturer target MPR is indicated alongside the SAR results. MPR is enabled for this device, according to 3GPP TS36.101 Section 6.2.3 – 6.2.5 under Table 6.2.3-1.

## 8.5.3 A-MPR

A-MPR (Additional MPR) has been disabled for all SAR tests by setting NS=01 on the base station simulator.

## 8.5.4 Required RB Size and RB Offsets for SAR Testing

According to FCC KDB 941225 D05v02r04:

- a. Per Section 5.2.1, SAR is required for QPSK 1 RB Allocation for the largest bandwidth
  - i. The required channel and offset combination with the highest maximum output power is required for SAR.
  - ii. When the reported SAR is  $\leq 0.8$  W/kg, testing of the remaining RB offset configurations and required test channels is not required. Otherwise, SAR is required for the remaining required test channels using the RB offset configuration with highest output power for that channel.
  - iii. When the reported SAR for a required test channel is  $> 1.45$  W/kg, SAR is required for all RB offset configurations for that channel.
- b. Per Section 5.2.2, SAR is required for 50% RB allocation using the largest bandwidth following the same procedures outlined in Section 5.2.1.
- c. Per Section 5.2.3, QPSK SAR is not required for the 100% allocation when the highest maximum output power for the 100% allocation is less than the highest maximum output power of the 1 RB and 50% RB allocations and the reported SAR for the 1 RB and 50% RB allocations is  $< 0.8$  W/kg.
- d. Per Section 5.2.4 and 5.3, SAR tests for higher order modulations and lower bandwidths configurations are not required when the conducted power of the required test configurations determined by Sections 5.2.1 through 5.2.3 is less than or equal to  $\frac{1}{2}$  dB higher than the equivalent configuration using QPSK modulation and when the QPSK SAR for those configurations is  $< 1.45$  W/kg.



## 8.6 SAR Testing with 802.11 Transmitters

The normal network operating configurations of 802.11 transmitters are not suitable for SAR measurements. Unpredictable fluctuations in network traffic and antenna diversity conditions can introduce undesirable variations in SAR results. The SAR for these devices should be measured using chipset based test mode software to ensure the results are consistent and reliable. See KDB Publication 248227 D01v02r02 for more details.

### 8.6.1 General Device Setup

Chipset based test mode software is hardware dependent and generally varies among manufacturers. The device operating parameters established in test mode for SAR measurements must be identical to those programmed in production units, including output power levels, amplifier gain settings and other RF performance tuning parameters.

A periodic duty factor is required for current generation SAR systems to measure SAR. When 802.11 frame gaps are accounted for in the transmission, a maximum transmission duty factor of 92 - 96% is typically achievable in most test mode configurations. A minimum transmission duty factor of 85% is required to avoid certain hardware and device implementation issues related to wide range SAR scaling. The reported SAR is scaled to 100% transmission duty factor to determine compliance at the maximum tune-up tolerance limit.

FCC ID: A3LSMJ530F		SAR EVALUATION REPORT		Approved by: Quality Manager
Document S/N: 1M1703200117-01.A3L	Test Dates: 03/20/17 - 04/05/17	DUT Type: Portable Handset		Page 19 of 49

## 8.6.2 U-NII-1 and U-NII-2A

For devices that operate in both U-NII-1 and U-NII-2A bands, when the same maximum output power is specified for both bands, SAR measurement using OFDM SAR test procedures is not required for U-NII-1 unless the highest reported SAR for U-NII-2A is  $> 1.2$  W/kg. When different maximum output powers are specified for the bands, SAR measurement for the U-NII band with the lower maximum output power is not required unless the highest reported SAR for the U-NII band with the higher maximum output power, adjusted by the ratio of lower to higher specified maximum output power for the two bands, is  $> 1.2$  W/kg.

## 8.6.3 U-NII-2C and U-NII-3

The frequency range covered by U-NII-2C and U-NII-3 is 380 MHz (5.47 – 5.85 GHz), which requires a minimum of at least two SAR probe calibration frequency points to support SAR measurements. When Terminal Doppler Weather Radar (TDWR) restriction applies, the channels at 5.60 – 5.65 GHz in U-NII-2C band must be disabled with acceptable mechanisms and documented in the equipment certification. Unless band gap channels are permanently disabled, SAR must be considered for these channels. Each band is tested independently according to the normally required OFDM SAR measurement and probe calibration frequency points requirements.

## 8.6.4 Initial Test Position Procedure

For exposure conditions with multiple test positions, such as handset operating next to the ear, devices with hotspot mode or UMPC mini-tablet, procedures for initial test position can be applied. Using the transmission mode determined by the DSSS procedure or initial test configuration, area scans are measured for all positions in an exposure condition. The test position with the highest extrapolated (peak) SAR is used as the initial test position. When reported SAR for the initial test position is  $\leq 0.4$  W/kg, no additional testing for the remaining test positions is required. Otherwise, SAR is evaluated at the subsequent highest peak SAR positions until the reported SAR result is  $\leq 0.8$  W/kg or all test positions are measured.

## 8.6.5 2.4 GHz SAR Test Requirements



SAR is measured for 2.4 GHz 802.11b DSSS using either the fixed test position or, when applicable, the initial test position procedure. SAR test reduction is determined according to the following:

- 1) When the reported SAR of the highest measured maximum output power channel for the exposure configuration is  $\leq 0.8$  W/kg, no further SAR testing is required for 802.11b DSSS in that exposure configuration.
- 2) When the reported SAR is  $> 0.8$  W/kg, SAR is required for that position using the next highest measured output power channel. When any reported SAR is  $> 1.2$  W/kg, SAR is required for the third channel; i.e., all channels require testing.

2.4 GHz 802.11 g/n OFDM are additionally evaluated for SAR if the highest reported SAR for 802.11b, adjusted by the ratio of the OFDM to DSSS specified maximum output power, is  $> 1.2$  W/kg. When SAR is required for OFDM modes in 2.4 GHz band, the Initial Test Configuration Procedures should be followed.

## 8.6.6 OFDM Transmission Mode and SAR Test Channel Selection

When the same maximum output power was specified for multiple OFDM transmission mode configurations in a frequency band or aggregated band, SAR is measured using the configuration with the largest channel bandwidth, lowest order modulation and lowest data rate. When the maximum output power of a channel is the same for equivalent OFDM configurations; for example, 802.11a, 802.11n and 802.11ac or 802.11g and 802.11n with the same channel bandwidth, modulation and data rate etc., the lower order 802.11 mode i.e., 802.11a, then 802.11n and 802.11ac or 802.11g then 802.11n, is used for SAR measurement. When the maximum output power are the same for multiple test channels, either according to the default or additional power measurement requirements, SAR is measured using the channel closest to the middle of the frequency band or aggregated band. When there are multiple channels with the same maximum output power, SAR is measured using the higher number channel.

FCC ID: A3LSMJ530F	 <b>PCTEST</b> ENGINEERING LABORATORY, INC.	<b>SAR EVALUATION REPORT</b>		<b>Approved by:</b> Quality Manager
Document S/N: 1M1703200117-01.A3L	Test Dates: 03/20/17 - 04/05/17	DUT Type: Portable Handset		Page 20 of 49



### 8.6.7 Initial Test Configuration Procedure

For OFDM, an initial test configuration is determined for each frequency band and aggregated band, according to the transmission mode with the highest maximum output power specified for SAR measurements. When the same maximum output power is specified for multiple OFDM transmission mode configurations in a frequency band or aggregated band, SAR is measured using the configuration(s) with the largest channel bandwidth, lowest order modulation, lowest data rate and lowest order IEEE 802.11 mode. The channel of the transmission mode with the highest average RF output conducted power will be the initial test configuration.

When the reported SAR is  $\leq 0.8$  W/kg, no additional measurements on other test channels are required. Otherwise, SAR is evaluated using the subsequent highest average RF output channel until the reported SAR result is  $\leq 1.2$  W/kg or all channels are measured. When there are multiple untested channels having the same subsequent highest average RF output power, the channel with higher frequency from the lowest 802.11 mode is considered for SAR measurements (See Section 8.6.6).

### 8.6.8 Subsequent Test Configuration Procedures

For OFDM configurations in each frequency band and aggregated band, SAR is evaluated for initial test configuration using the fixed test position or the initial test position procedure. When the highest reported SAR (for the initial test configuration), adjusted by the ratio of the specified maximum output power of the subsequent test configuration to initial test configuration, is  $\leq 1.2$  W/kg, no additional SAR tests for the subsequent test configurations are required.



FCC ID: A3LSMJ530F	 <b>SAR EVALUATION REPORT</b> 		<b>Approved by:</b> Quality Manager
Document S/N: 1M1703200117-01.A3L	<b>Test Dates:</b> 03/20/17 - 04/05/17	<b>DUT Type:</b> Portable Handset	Page 21 of 49

# 9 RF CONDUCTED POWERS

## 9.1 GSM Conducted Powers

**Table 9-1  
Maximum Conducted Powers**

Maximum Burst-Averaged Output Power										
Band	Channel	Voice	GPRS/EDGE Data (GMSK)				EDGE Data (8-PSK)			
		GSM [dBm] CS (1 Slot)	GPRS [dBm] 1 Tx Slot	GPRS [dBm] 2 Tx Slot	GPRS [dBm] 3 Tx Slot	GPRS [dBm] 4 Tx Slot	EDGE [dBm] 1 Tx Slot	EDGE [dBm] 2 Tx Slot	EDGE [dBm] 3 Tx Slot	EDGE [dBm] 4 Tx Slot
GSM 850	128	32.62	32.65	30.55	<b>29.34</b>	27.83	27.32	24.94	23.52	22.07
	190	32.74	32.75	30.71	<b>29.31</b>	27.86	27.21	25.05	23.32	21.89
	251	32.76	32.88	30.79	<b>29.34</b>	27.89	27.24	25.06	23.48	21.92
GSM 1900	512	29.51	29.54	26.55	25.18	<b>23.95</b>	25.77	23.64	22.04	20.63
	661	29.32	29.39	26.25	24.84	<b>23.62</b>	25.26	23.21	21.69	20.13
	810	29.59	29.67	26.72	25.24	<b>23.94</b>	25.84	23.54	21.92	20.38
Calculated Maximum Frame-Averaged Output Power										
Band	Channel	Voice	GPRS/EDGE Data (GMSK)				EDGE Data (8-PSK)			
		GSM [dBm] CS (1 Slot)	GPRS [dBm] 1 Tx Slot	GPRS [dBm] 2 Tx Slot	GPRS [dBm] 3 Tx Slot	GPRS [dBm] 4 Tx Slot	EDGE [dBm] 1 Tx Slot	EDGE [dBm] 2 Tx Slot	EDGE [dBm] 3 Tx Slot	EDGE [dBm] 4 Tx Slot
GSM 850	128	23.59	23.62	24.53	<b>25.08</b>	24.82	18.29	18.92	19.26	19.06
	190	23.71	23.72	24.69	<b>25.05</b>	24.85	18.18	19.03	19.06	18.88
	251	23.73	23.85	24.77	<b>25.08</b>	24.88	18.21	19.04	19.22	18.91
GSM 1900	512	20.48	20.51	20.53	20.92	<b>20.94</b>	16.74	17.62	17.78	17.62
	661	20.29	20.36	20.23	20.58	<b>20.61</b>	16.23	17.19	17.43	17.12
	810	20.56	20.64	20.70	20.98	<b>20.93</b>	16.81	17.52	17.66	17.37
GSM 850	Frame	23.97	23.97	25.48	<b>25.74</b>	25.49	18.47	19.48	19.74	19.49
GSM 1900	Avg. Targets:	20.97	20.97	21.48	21.24	<b>21.49</b>	16.47	17.98	18.24	17.99

FCC ID: A3LSMJ530F		<b>SAR EVALUATION REPORT</b>		<b>Approved by:</b> Quality Manager
Document S/N: 1M1703200117-01.A3L	Test Dates: 03/20/17 - 04/05/17	DUT Type: Portable Handset	Page 22 of 49	

**Table 9-2  
Reduced Conducted Powers**

Maximum Burst-Averaged Output Power									
Band	Channel	GPRS/EDGE Data (GMSK)				EDGE Data (8-PSK)			
		GPRS [dBm] 1 Tx Slot	GPRS [dBm] 2 Tx Slot	GPRS [dBm] 3 Tx Slot	GPRS [dBm] 4 Tx Slot	EDGE [dBm] 1 Tx Slot	EDGE [dBm] 2 Tx Slot	EDGE [dBm] 3 Tx Slot	EDGE [dBm] 4 Tx Slot
GSM 850	128	31.00	29.19	<b>27.76</b>	26.32	26.75	25.17	23.57	22.16
	190	30.92	29.13	<b>27.78</b>	26.20	26.58	24.93	23.49	22.13
	251	31.06	29.23	<b>27.74</b>	26.31	26.82	25.12	23.54	22.21
GSM 1900	512	28.40	25.11	23.96	<b>23.00</b>	26.00	24.00	22.45	21.40
	661	27.73	24.66	23.28	<b>22.23</b>	25.35	23.29	21.65	20.48
	810	28.04	24.95	23.56	<b>22.41</b>	25.81	23.70	22.18	20.90
Calculated Maximum Frame-Averaged Output Power									
Band	Channel	GPRS/EDGE Data (GMSK)				EDGE Data (8-PSK)			
		GPRS [dBm] 1 Tx Slot	GPRS [dBm] 2 Tx Slot	GPRS [dBm] 3 Tx Slot	GPRS [dBm] 4 Tx Slot	EDGE [dBm] 1 Tx Slot	EDGE [dBm] 2 Tx Slot	EDGE [dBm] 3 Tx Slot	EDGE [dBm] 4 Tx Slot
GSM 850	128	21.97	23.17	<b>23.50</b>	23.31	17.72	19.15	19.31	19.15
	190	21.89	23.11	<b>23.52</b>	23.19	17.55	18.91	19.23	19.12
	251	22.03	23.21	<b>23.48</b>	23.30	17.79	19.10	19.28	19.20
GSM 1900	512	19.37	19.09	19.70	<b>19.99</b>	16.97	17.98	18.19	18.39
	661	18.70	18.64	19.02	<b>19.22</b>	16.32	17.27	17.39	17.47
	810	19.01	18.93	19.30	<b>19.40</b>	16.78	17.68	17.92	17.89
GSM 850	Frame	21.97	23.48	<b>23.74</b>	23.49	18.47	19.48	19.74	19.49
GSM 1900	Avg. Targets:	18.97	19.48	19.24	<b>19.49</b>	16.47	17.98	18.24	17.99

Note:

- Both burst-averaged and calculated frame-averaged powers are included. Frame-averaged power was calculated from the measured burst-averaged power by converting the slot powers into linear units and calculating the energy over 8 timeslots.
- GPRS/EDGE (GMSK) output powers were measured with coding scheme setting of 1 (CS1) on the base station simulator. CS1 was configured to measure GPRS output power measurements and SAR to ensure GMSK modulation in the signal. Our Investigation has shown that CS1 - CS4 settings do not have any impact on the output levels or modulation in the GPRS modes.
- EDGE (8-PSK) output powers were measured with MCS7 on the base station simulator. MCS7 coding scheme was used to measure the output powers for EDGE since investigation has shown that choosing MCS7 coding scheme will ensure 8-PSK modulation. It has been shown that MCS levels that produce 8PSK modulation do not have an impact on output power.

**GSM Class: B**  
**GPRS Multislot class: 33 (Max 4 Tx uplink slots)**  
**EDGE Multislot class: 33 (Max 4 Tx uplink slots)**  
**DTM Multislot Class: N/A**



**Figure 9-1  
Power Measurement Setup**

FCC ID: A3LSMJ530F		SAR EVALUATION REPORT		Approved by: Quality Manager
Document S/N: 1M1703200117-01.A3L	Test Dates: 03/20/17 - 04/05/17	DUT Type: Portable Handset	Page 23 of 49	

## 9.2 UMTS Conducted Powers

**Table 9-3  
Maximum Conducted Powers**

3GPP Release Version	Mode	3GPP 34.121 Subtest	Cellular Band [dBm]			AWS Band [dBm]			PCS Band [dBm]			3GPP MPR [dB]
			4132	4183	4233	1312	1412	1513	9262	9400	9538	
99	WCDMA	12.2 kbps RMC	23.75	23.77	23.66	23.05	22.96	22.91	22.65	22.77	22.61	-
99		12.2 kbps AMR	23.77	21.81	23.67	23.07	21.52	22.85	22.68	21.11	22.56	-
6	HSDPA	Subtest 1	22.70	22.63	22.56	22.63	22.68	22.57	22.58	22.72	22.58	0
6		Subtest 2	21.85	21.77	21.73	22.03	21.80	21.76	22.14	21.87	22.04	0
6		Subtest 3	21.32	21.24	21.13	21.05	21.04	20.84	21.28	20.95	21.08	0.5
6		Subtest 4	21.31	21.26	21.17	20.96	20.94	20.83	21.07	21.02	21.09	0.5
6	HSUPA	Subtest 1	20.15	20.05	20.00	21.92	21.88	21.69	21.93	21.93	19.86	0
6		Subtest 2	18.51	18.43	18.36	20.86	20.89	20.71	18.64	18.49	19.07	2
6		Subtest 3	21.29	21.18	21.12	21.72	21.61	21.65	21.25	20.91	20.91	1
6		Subtest 4	18.76	18.69	18.65	20.85	20.76	20.70	18.57	18.21	18.49	2
6		Subtest 5	22.68	22.65	22.55	22.91	22.80	22.71	22.41	22.66	22.46	0
8	DC-HSDPA	Subtest 1	22.80	22.76	22.73	22.84	22.77	22.76	22.27	22.10	22.33	0
8		Subtest 2	22.17	22.32	22.45	21.88	21.83	21.90	22.26	22.07	22.35	0
8		Subtest 3	21.56	21.30	21.30	21.03	21.43	21.32	21.30	21.22	21.01	0.5
8		Subtest 4	21.45	21.46	21.24	21.02	20.92	21.06	21.04	20.90	21.08	0.5

**Table 9-4  
Reduced Conducted Powers**

3GPP Release Version	Mode	3GPP 34.121 Subtest	AWS Band [dBm]			PCS Band [dBm]			3GPP MPR [dB]
			1312	1412	1513	9262	9400	9538	
99	WCDMA	12.2 kbps RMC	18.90	19.30	19.38	19.88	19.17	19.60	-
99		12.2 kbps AMR	18.70	18.99	19.27	19.89	19.20	19.58	-
6	HSDPA	Subtest 1	19.03	18.96	18.82	19.02	19.30	19.08	0
6		Subtest 2	19.05	18.70	18.88	19.25	19.36	19.02	0
6		Subtest 3	19.06	19.00	18.91	19.40	19.50	19.10	0.5
6		Subtest 4	19.06	18.88	18.89	19.27	19.40	19.14	0.5
6	HSUPA	Subtest 1	17.94	17.72	17.61	18.44	18.37	18.24	0
6		Subtest 2	17.85	17.75	17.68	18.27	18.01	18.06	2
6		Subtest 3	17.79	17.72	17.64	18.24	18.35	18.29	1
6		Subtest 4	19.02	18.78	18.74	18.25	17.91	18.11	2
6		Subtest 5	18.86	19.00	18.95	19.40	19.58	19.36	0
8	DC-HSDPA	Subtest 1	18.90	19.26	19.44	19.73	19.18	19.56	0
8		Subtest 2	19.02	19.20	19.39	19.78	19.43	19.51	0
8		Subtest 3	18.99	18.97	19.21	19.34	19.10	19.50	0.5
8		Subtest 4	18.99	19.01	19.48	19.35	18.95	19.54	0.5



### DC-HSDPA considerations

- 3GPP Specification 34.121-1 Release 8 Ver 8.10.0 was used for DC-HSDPA guidance
- H-Set 12 (QPSK) was confirmed to be used during DC-HSDPA measurements
- The DUT supports UE category 24 for HSDPA

It is expected by the manufacturer that MPR for some HSPA subtests may be up to 2 dB more than specified by 3GPP, but also as low as 0 dB according to the chipset implementation in this model.



**Figure 9-2  
Power Measurement Setup**

FCC ID: A3LSMJ530F		SAR EVALUATION REPORT		Approved by: Quality Manager
Document S/N: 1M1703200117-01.A3L	Test Dates: 03/20/17 - 04/05/17	DUT Type: Portable Handset	Page 24 of 49	

### 9.3 LTE Conducted Powers

#### 9.3.1 LTE Band 5 (Cell)



**Table 9-5  
LTE Band 5 (Cell) Conducted Powers - 10 MHz Bandwidth**

LTE Band 5 (Cell) 10 MHz Bandwidth					
Modulation	RB Size	RB Offset	Mid Channel	MPR Allowed per 3GPP [dB]	MPR [dB]
			20525 (836.5 MHz)		
			Conducted Power [dBm]		
QPSK	1	0	23.71	0	0
	1	25	<b>24.02</b>		0
	1	49	23.95		0
	25	0	<b>22.90</b>	0-1	1
	25	12	22.85		1
	25	25	22.82		1
	50	0	22.85		1
16QAM	1	0	22.74	0-1	1
	1	25	22.72		1
	1	49	22.71		1
	25	0	21.87	0-2	2
	25	12	21.87		2
	25	25	21.82		2
	50	0	21.89		2

Note: LTE Band 5 (Cell) at 10 MHz bandwidth does not support three non-overlapping channels. Per KDB Publication 941225 D05v02, when a device supports overlapping channel assignment in a channel bandwidth configuration, the middle channel of the group of overlapping channels should be selected for testing.

**Table 9-6  
LTE Band 5 (Cell) Conducted Powers - 5 MHz Bandwidth**

LTE Band 5 (Cell) 5 MHz Bandwidth							
Modulation	RB Size	RB Offset	Low Channel	Mid Channel	High Channel	MPR Allowed per 3GPP [dB]	MPR [dB]
			20425 (826.5 MHz)	20525 (836.5 MHz)	20625 (846.5 MHz)		
			Conducted Power [dBm]				
QPSK	1	0	23.97	23.87	23.72	0	0
	1	12	23.97	23.70	23.73		0
	1	24	23.89	23.72	23.81		0
	12	0	23.00	22.88	22.81	0-1	1
	12	6	23.01	22.83	22.78		1
	12	13	22.96	22.84	22.82		1
	25	0	23.09	22.87	22.81		1
16QAM	1	0	22.88	22.87	22.88	0-1	1
	1	12	22.84	22.93	22.94		1
	1	24	22.84	22.88	22.84		1
	12	0	22.15	21.99	21.90	0-2	2
	12	6	22.04	21.91	21.80		2
	12	13	22.03	21.95	21.90		2
	25	0	22.08	21.85	21.81		2



FCC ID: A3LSMJ530F	 PCTEST ENGINEERING LABORATORY, INC.	SAR EVALUATION REPORT		Approved by: Quality Manager
Document S/N: 1M1703200117-01.A3L	Test Dates: 03/20/17 - 04/05/17	DUT Type: Portable Handset		Page 25 of 49

**Table 9-7**  
**LTE Band 5 (Cell) Conducted Powers - 3 MHz Bandwidth**

LTE Band 5 (Cell) 3 MHz Bandwidth							
Modulation	RB Size	RB Offset	Low Channel	Mid Channel	High Channel	MPR Allowed per 3GPP [dB]	MPR [dB]
			20415 (825.5 MHz)	20525 (836.5 MHz)	20635 (847.5 MHz)		
			Conducted Power [dBm]				
QPSK	1	0	23.98	23.76	23.82	0	0
	1	7	24.06	23.69	23.74		0
	1	14	23.87	23.69	23.78		0
	8	0	23.11	22.81	22.84	0-1	1
	8	4	23.12	22.91	22.71		1
	8	7	22.89	22.84	22.72		1
	15	0	23.11	22.85	22.68		1
16QAM	1	0	22.92	22.72	22.98	0-1	1
	1	7	22.82	23.04	22.91		1
	1	14	23.01	22.76	22.91		1
	8	0	21.98	21.93	21.86	0-2	2
	8	4	22.04	21.88	21.90		2
	8	7	22.02	21.91	21.90		2
	15	0	22.06	21.82	21.83		2

**Table 9-8**  
**LTE Band 5 (Cell) Conducted Powers - 1.4 MHz Bandwidth**

LTE Band 5 (Cell) 1.4 MHz Bandwidth							
Modulation	RB Size	RB Offset	Low Channel	Mid Channel	High Channel	MPR Allowed per 3GPP [dB]	MPR [dB]
			20407 (824.7 MHz)	20525 (836.5 MHz)	20643 (848.3 MHz)		
			Conducted Power [dBm]				
QPSK	1	0	23.97	23.85	23.71	0	0
	1	2	23.94	23.70	23.70		0
	1	5	23.77	23.54	23.75		0
	3	0	23.97	23.87	23.80		0
	3	2	24.00	23.81	23.88		0
	3	3	23.87	23.84	23.74		0
	6	0	23.18	22.97	22.87	0-1	1
16QAM	1	0	22.76	22.72	22.80	0-1	1
	1	2	22.88	23.06	23.08		1
	1	5	22.71	22.80	22.75		1
	3	0	23.01	22.99	22.85		1
	3	2	23.07	22.81	22.89		1
	3	3	22.86	22.89	22.83		1
	6	0	21.94	21.76	21.70	0-2	2

FCC ID: A3LSMJ530F	 <b>PCTEST</b> ENGINEERING LABORATORY, INC.	<b>SAR EVALUATION REPORT</b>		<b>Approved by:</b> Quality Manager
Document S/N: 1M1703200117-01.A3L	Test Dates: 03/20/17 - 04/05/17	DUT Type: Portable Handset	Page 26 of 49	



## 9.4 WLAN Conducted Powers

**Table 9-9**  
**2.4 GHz WLAN Maximum Average RF Power**

Freq [MHz]	Channel	2.4GHz Conducted Power [dBm]	
		IEEE Transmission Mode	
		802.11b	802.11g
2412	1	18.01	14.79
2437	6	<b>18.04</b>	14.95
2462	11	17.97	14.70

**Table 9-10**  
**5 GHz WLAN Maximum Average RF Power**

Freq [MHz]	Channel	5GHz (20MHz) Conducted Power [dBm]
		IEEE Transmission Mode
		802.11a
5180	36	13.74
5200	40	13.73
5220	44	13.63
5240	48	13.74
5260	52	<b>14.23</b>
5280	56	14.22
5300	60	14.20
5320	64	14.12
5500	100	<b>14.08</b>
5600	120	14.01
5620	124	13.96
5720	144	13.98
5745	149	<b>14.21</b>
5785	157	14.08
5825	165	14.06



FCC ID: A3LSMJ530F		<b>SAR EVALUATION REPORT</b>		<b>Approved by:</b> Quality Manager
Document S/N: 1M1703200117-01.A3L	Test Dates: 03/20/17 - 04/05/17	DUT Type: Portable Handset	Page 27 of 49	

**Table 9-11**  
**2.4 GHz WLAN Reduced Average RF Power**

Freq [MHz]	Channel	2.4GHz Conducted Power [dBm]	
		IEEE Transmission Mode	
		802.11b	802.11g
2412	1	16.07	13.28
2437	6	15.79	13.06
2462	11	16.02	13.01

**Table 9-12**  
**5 GHz WLAN Reduced Average RF Power**

Freq [MHz]	Channel	5GHz (20MHz) Conducted Power [dBm]
		IEEE Transmission Mode
		802.11a
5180	36	12.00
5200	40	11.83
5220	44	11.93
5240	48	11.82
5260	52	12.42
5280	56	12.38
5300	60	12.33
5320	64	12.27
5500	100	12.39
5600	120	12.38
5620	124	11.80
5720	144	11.71
5745	149	11.74
5785	157	11.63
5825	165	11.66



<b>FCC ID:</b> A3LSMJ530F	 <b>PCTEST</b> ENGINEERING LABORATORY, INC.	<b>SAR EVALUATION REPORT</b>		<b>Approved by:</b> Quality Manager
<b>Document S/N:</b> 1M1703200117-01.A3L	<b>Test Dates:</b> 03/20/17 - 04/05/17	<b>DUT Type:</b> Portable Handset	Page 28 of 49	

Justification for test configurations for WLAN per KDB Publication 248227 D01v02r02:

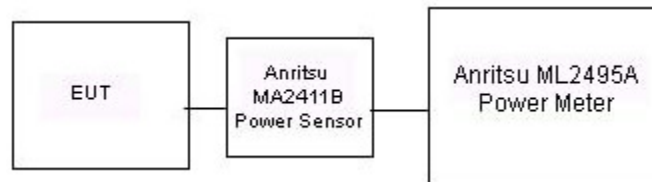
- Power measurements were performed for the transmission mode configuration with the highest maximum output power specified for production units.
- For transmission modes with the same maximum output power specification, powers were measured for the largest channel bandwidth, lowest order modulation and lowest data rate.
- For transmission modes with identical maximum specified output power, channel bandwidth, modulation and data rates, power measurements were required for all identical configurations.
- For each transmission mode configuration, powers were measured for the highest and lowest channels; and at the mid-band channel(s) when there were at least 3 channels supported. For configurations with multiple mid-band channels, due to an even number of channels, both channels were measured.
- The bolded data rate and channel above were tested for SAR.



**Figure 9-3**  
**Power Measurement Setup for Bandwidths**

<b>FCC ID:</b> A3LSMJ530F	 <b>PCTEST</b> ENGINEERING LABORATORY, INC.		<b>SAR EVALUATION REPORT</b>		<b>Approved by:</b> Quality Manager
<b>Document S/N:</b> 1M1703200117-01.A3L	<b>Test Dates:</b> 03/20/17 - 04/05/17	<b>DUT Type:</b> Portable Handset		Page 29 of 49	



# 10 SYSTEM VERIFICATION

## 10.1 Tissue Verification

**Table 10-1  
Measured Tissue Properties**

Calibrated for Tests Performed on:	Tissue Type	Tissue Temp During Calibration (°C)	Measured Frequency (MHz)	Measured Conductivity, $\sigma$ (S/m)	Measured Dielectric Constant, $\epsilon$	TARGET Conductivity, $\sigma$ (S/m)	TARGET Dielectric Constant, $\epsilon$	% dev $\sigma$	% dev $\epsilon$
03/20/2017	835H	20.5	820	0.882	40.635	0.899	41.578	-1.89%	-2.27%
			835	0.896	40.456	0.900	41.500	-0.44%	-2.52%
			850	0.909	40.372	0.916	41.500	-0.76%	-2.72%
03/22/2017	835H	21.8	820	0.878	43.169	0.899	41.578	-2.34%	3.83%
			835	0.895	42.965	0.900	41.500	-0.56%	3.53%
			850	0.909	42.861	0.916	41.500	-0.76%	3.28%
03/22/2017	1750H	21.0	1710	1.296	39.083	1.348	40.142	-3.86%	-2.64%
			1750	1.338	38.950	1.371	40.079	-2.41%	-2.82%
			1790	1.382	38.737	1.394	40.016	-0.86%	-3.20%
03/20/2017	1900H	21.1	1850	1.400	39.561	1.400	40.000	0.00%	-1.10%
			1880	1.428	39.495	1.400	40.000	2.00%	-1.26%
			1910	1.461	39.306	1.400	40.000	4.36%	-1.74%
03/23/2017	2450H	22.9	2400	1.795	38.168	1.756	39.289	2.22%	-2.85%
			2450	1.854	37.914	1.800	39.200	3.00%	-3.28%
			2500	1.911	37.714	1.855	39.136	3.02%	-3.63%
03/27/2017	5200H-5800H	22.9	5240	4.637	35.513	4.696	35.940	-1.26%	-1.19%
			5260	4.657	35.474	4.717	35.917	-1.27%	-1.23%
			5280	4.672	35.435	4.737	35.894	-1.37%	-1.28%
			5500	4.900	35.138	4.963	35.643	-1.27%	-1.42%
			5600	5.015	34.923	5.065	35.529	-0.99%	-1.71%
			5745	5.151	34.773	5.214	35.363	-1.21%	-1.67%
			5765	5.174	34.731	5.234	35.340	-1.15%	-1.72%
			5825	5.234	34.627	5.296	35.271	-1.17%	-1.83%
03/27/2017	835B	21.5	820	0.978	54.228	0.969	55.258	0.93%	-1.86%
			835	0.992	54.075	0.970	55.200	2.27%	-2.04%
			850	1.006	53.930	0.988	55.154	1.82%	-2.22%
04/05/2017	1750B	23.0	1710	1.429	52.581	1.463	53.537	-2.32%	-1.79%
			1750	1.474	52.407	1.488	53.432	-0.94%	-1.92%
			1790	1.516	52.268	1.514	53.326	0.13%	-1.98%
03/27/2017	1900B	22.5	1850	1.517	52.532	1.520	53.300	-0.20%	-1.44%
			1880	1.552	52.413	1.520	53.300	2.11%	-1.66%
			1910	1.584	52.283	1.520	53.300	4.21%	-1.91%
03/23/2017	2450B	22.0	2400	1.936	51.980	1.902	52.767	1.79%	-1.49%
			2450	2.007	51.801	1.950	52.700	2.92%	-1.71%
			2500	2.079	51.605	2.021	52.636	2.87%	-1.96%
03/29/2017	2450B	22.1	2400	1.948	51.178	1.902	52.767	2.42%	-3.01%
			2450	2.011	50.977	1.950	52.700	3.13%	-3.27%
			2500	2.081	50.801	2.021	52.636	2.97%	-3.49%
03/20/2017	5200B-5800B	20.8	5240	5.520	47.071	5.346	48.960	3.25%	-3.86%
			5260	5.528	47.004	5.369	48.933	2.96%	-3.94%
			5500	5.844	46.679	5.650	48.607	3.43%	-3.97%
			5600	6.009	46.520	5.766	48.471	4.21%	-4.03%
			5745	6.198	46.289	5.936	48.275	4.41%	-4.11%
			5765	6.219	46.283	5.959	48.248	4.36%	-4.07%
03/28/2017	5200B-5800B	22.3	5785	6.232	46.219	5.982	48.220	4.18%	-4.15%
			5745	6.141	46.567	5.936	48.275	3.45%	-3.54%
			5765	6.172	46.512	5.959	48.248	3.57%	-3.60%

The above measured tissue parameters were used in the DASY software. The DASY software was used to perform interpolation to determine the dielectric parameters at the SAR test device frequencies (per KDB Publication 865664 D01v01r04 and IEEE 1528-2013 6.6.1.2). The tissue parameters listed in the SAR test plots may slightly differ from the table above due to significant digit rounding in the software.

FCC ID: A3LSMJ530F	 PCTEST ENGINEERING LABORATORY, INC.	SAR EVALUATION REPORT		Approved by: Quality Manager
Document S/N: 1M1703200117-01.A3L	Test Dates: 03/20/17 - 04/05/17	DUT Type: Portable Handset		Page 30 of 49

## 10.2 Test System Verification

Prior to SAR assessment, the system is verified to  $\pm 10\%$  of the SAR measurement on the reference dipole at the time of calibration by the calibration facility. Full system validation status and result summary can be found in Appendix E.

**Table 10-2  
System Verification Results**

System Verification TARGET & MEASURED												
SAR System #	Tissue Frequency (MHz)	Tissue Type	Date:	Amb. Temp (°C)	Liquid Temp (°C)	Input Power (W)	Dipole SN	Probe SN	Measured SAR <sub>1g</sub> (W/kg)	1 W Target SAR <sub>1g</sub> (W/kg)	1 W Normalized SAR <sub>1g</sub> (W/kg)	Deviation <sub>1g</sub> (%)
E	835	HEAD	03/20/2017	22.3	20.5	0.200	4d047	7406	1.920	9.130	9.600	5.15%
J	835	HEAD	03/22/2017	21.3	21.8	0.200	4d047	3334	1.910	9.130	9.550	4.60%
H	1750	HEAD	03/22/2017	24.1	22.0	0.100	1008	3318	3.490	36.700	34.900	-4.90%
H	1900	HEAD	03/20/2017	22.0	21.3	0.100	5d149	3318	3.870	40.100	38.700	-3.49%
G	2450	HEAD	03/23/2017	21.3	22.9	0.100	797	3287	5.370	52.100	53.700	3.07%
K	5250	HEAD	03/27/2017	22.7	21.0	0.050	1237	7308	3.850	79.200	77.000	-2.78%
K	5600	HEAD	03/27/2017	22.7	21.0	0.050	1237	7308	4.090	83.300	81.800	-1.80%
K	5750	HEAD	03/27/2017	22.7	21.0	0.050	1237	7308	3.780	81.500	75.600	-7.24%
H	835	BODY	03/27/2017	21.4	21.5	0.200	4d047	3318	1.980	9.570	9.900	3.45%
I	1750	BODY	04/05/2017	24.0	23.0	0.100	1008	3213	3.750	37.300	37.500	0.54%
G	1900	BODY	03/27/2017	21.8	22.3	0.100	5d080	3287	4.170	39.100	41.700	6.65%
E	2450	BODY	03/23/2017	22.3	22.0	0.100	981	7406	4.980	50.800	49.800	-1.97%
E	2450	BODY	03/29/2017	23.5	22.1	0.100	981	7406	4.770	50.800	47.700	-6.10%
K	5250	BODY	03/20/2017	23.1	21.0	0.050	1237	7308	3.680	74.800	73.600	-1.60%
K	5600	BODY	03/20/2017	23.1	21.0	0.050	1237	7308	4.060	77.000	81.200	5.45%
K	5750	BODY	03/20/2017	23.1	21.0	0.050	1237	7308	3.530	75.400	70.600	-6.37%
D	5750	BODY	03/28/2017	23.5	22.3	0.050	1237	3589	3.550	75.400	71.000	-5.84%

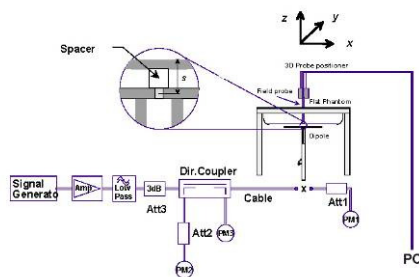

**Figure 10-1  
System Verification Setup Diagram**



**Figure 10-2  
System Verification Setup Photo**

FCC ID: A3LSMJ530F		SAR EVALUATION REPORT		Approved by: Quality Manager
Document S/N: 1M1703200117-01.A3L	Test Dates: 03/20/17 - 04/05/17	DUT Type: Portable Handset		Page 31 of 49

# 11 SAR DATA SUMMARY

## 11.1 Standalone Head SAR Data

**Table 11-1  
GSM 850 Head SAR**



MEASUREMENT RESULTS														
FREQUENCY		Mode/Band	Service	Maximum Allowed Power [dBm]	Conducted Power [dBm]	Power Drift [dB]	Side	Test Position	Device Serial Number	Duty Cycle	SAR (1g)	Scaling Factor	Reported SAR (1g)	Plot #
MHz	Ch.										(W/kg)		(W/kg)	
836.60	190	GSM 850	GSM	33.5	32.74	0.20	Right	Cheek	11456	1:8.3	0.037	1.191	0.044	A1
836.60	190	GSM 850	GSM	33.5	32.74	-0.04	Right	Tilt	11456	1:8.3	0.020	1.191	0.024	
836.60	190	GSM 850	GSM	33.5	32.74	0.15	Left	Cheek	11456	1:8.3	0.034	1.191	0.040	
836.60	190	GSM 850	GSM	33.5	32.74	0.11	Left	Tilt	11456	1:8.3	0.021	1.191	0.025	
ANSI / IEEE C95.1 1992 - SAFETY LIMIT Spatial Peak Uncontrolled Exposure/General Population							Head 1.6 W/kg (mW/g) averaged over 1 gram							

**Table 11-2  
GSM 1900 Head SAR**

MEASUREMENT RESULTS														
FREQUENCY		Mode/Band	Service	Maximum Allowed Power [dBm]	Conducted Power [dBm]	Power Drift [dB]	Side	Test Position	Device Serial Number	Duty Cycle	SAR (1g)	Scaling Factor	Reported SAR (1g)	Plot #
MHz	Ch.										(W/kg)		(W/kg)	
1880.00	661	GSM 1900	GSM	30.5	29.32	0.20	Right	Cheek	11456	1:8.3	0.046	1.312	0.060	
1880.00	661	GSM 1900	GSM	30.5	29.32	0.12	Right	Tilt	11456	1:8.3	0.023	1.312	0.030	
1880.00	661	GSM 1900	GSM	30.5	29.32	0.18	Left	Cheek	11456	1:8.3	0.058	1.312	0.076	A2
1880.00	661	GSM 1900	GSM	30.5	29.32	0.18	Left	Tilt	11456	1:8.3	0.019	1.312	0.025	
ANSI / IEEE C95.1 1992 - SAFETY LIMIT Spatial Peak Uncontrolled Exposure/General Population							Head 1.6 W/kg (mW/g) averaged over 1 gram							

**Table 11-3  
UMTS 850 Head SAR**

MEASUREMENT RESULTS														
FREQUENCY		Mode/Band	Service	Maximum Allowed Power [dBm]	Conducted Power [dBm]	Power Drift [dB]	Side	Test Position	Device Serial Number	Duty Cycle	SAR (1g)	Scaling Factor	Reported SAR (1g)	Plot #
MHz	Ch.										(W/kg)		(W/kg)	
836.60	4183	UMTS 850	RMC	23.8	23.77	-0.01	Right	Cheek	29760	1:1	0.107	1.007	0.108	A3
836.60	4183	UMTS 850	RMC	23.8	23.77	0.09	Right	Tilt	29760	1:1	0.043	1.007	0.043	
836.60	4183	UMTS 850	RMC	23.8	23.77	0.12	Left	Cheek	29760	1:1	0.079	1.007	0.080	
836.60	4183	UMTS 850	RMC	23.8	23.77	0.12	Left	Tilt	29760	1:1	0.043	1.007	0.043	
ANSI / IEEE C95.1 1992 - SAFETY LIMIT Spatial Peak Uncontrolled Exposure/General Population							Head 1.6 W/kg (mW/g) averaged over 1 gram							

FCC ID: A3LSMJ530F		<b>SAR EVALUATION REPORT</b>		<b>Approved by:</b> Quality Manager
Document S/N: 1M1703200117-01.A3L	Test Dates: 03/20/17 - 04/05/17	DUT Type: Portable Handset	Page 32 of 49	

**Table 11-4  
UMTS 1750 Head SAR**



MEASUREMENT RESULTS														
FREQUENCY		Mode/Band	Service	Maximum Allowed Power [dBm]	Conducted Power [dBm]	Power Drift [dB]	Side	Test Position	Device Serial Number	Duty Cycle	SAR (1g)	Scaling Factor	Reported SAR (1g)	Plot #
MHz	Ch.										(W/kg)		(W/kg)	
1732.40	1412	UMTS 1750	RMC	23.5	22.96	0.09	Right	Cheek	12355	1:1	0.059	1.132	0.067	
1732.40	1412	UMTS 1750	RMC	23.5	22.96	0.05	Right	Tilt	12355	1:1	0.030	1.132	0.034	
1732.40	1412	UMTS 1750	RMC	23.5	22.96	0.05	Left	Cheek	12355	1:1	0.079	1.132	0.089	A4
1732.40	1412	UMTS 1750	RMC	23.5	22.96	0.11	Left	Tilt	12355	1:1	0.029	1.132	0.033	
ANSI / IEEE C95.1 1992 - SAFETY LIMIT Spatial Peak Uncontrolled Exposure/General Population							Head 1.6 W/kg (mW/g) averaged over 1 gram							

**Table 11-5  
UMTS 1900 Head SAR**

MEASUREMENT RESULTS														
FREQUENCY		Mode/Band	Service	Maximum Allowed Power [dBm]	Conducted Power [dBm]	Power Drift [dB]	Side	Test Position	Device Serial Number	Duty Cycle	SAR (1g)	Scaling Factor	Reported SAR (1g)	Plot #
MHz	Ch.										(W/kg)		(W/kg)	
1880.00	9400	UMTS 1900	RMC	23.0	22.77	0.10	Right	Cheek	11456	1:1	0.105	1.054	0.111	
1880.00	9400	UMTS 1900	RMC	23.0	22.77	0.10	Right	Tilt	11456	1:1	0.043	1.054	0.045	
1880.00	9400	UMTS 1900	RMC	23.0	22.77	0.10	Left	Cheek	11456	1:1	0.117	1.054	0.123	A5
1880.00	9400	UMTS 1900	RMC	23.0	22.77	0.17	Left	Tilt	11456	1:1	0.039	1.054	0.041	
ANSI / IEEE C95.1 1992 - SAFETY LIMIT Spatial Peak Uncontrolled Exposure/General Population							Head 1.6 W/kg (mW/g) averaged over 1 gram							

**Table 11-6  
LTE Band 5 (Cell) Head SAR**

MEASUREMENT RESULTS																			
FREQUENCY		Mode	Bandwidth [MHz]	Maximum Allowed Power [dBm]	Conducted Power [dBm]	Power Drift [dB]	MPR [dB]	Side	Test Position	Modulation	RB Size	RB Offset	Device Serial Number	Duty Cycle	SAR (1g)	Scaling Factor	Reported SAR (1g)	Plot #	
MHz	Ch.														(W/kg)		(W/kg)		
836.50	20525	Mid	LTE Band 5 (Cell)	10	25.0	24.02	0.14	0	Right	Cheek	QPSK	1	25	11456	1:1	0.045	1.253	0.056	
836.50	20525	Mid	LTE Band 5 (Cell)	10	24.0	22.90	0.17	1	Right	Cheek	QPSK	25	0	11456	1:1	0.035	1.288	0.045	
836.50	20525	Mid	LTE Band 5 (Cell)	10	25.0	24.02	0.20	0	Right	Tilt	QPSK	1	25	11456	1:1	0.025	1.253	0.031	
836.50	20525	Mid	LTE Band 5 (Cell)	10	24.0	22.90	0.17	1	Right	Tilt	QPSK	25	0	11456	1:1	0.021	1.288	0.027	
836.50	20525	Mid	LTE Band 5 (Cell)	10	25.0	24.02	-0.02	0	Left	Cheek	QPSK	1	25	11456	1:1	0.047	1.253	0.059	A6
836.50	20525	Mid	LTE Band 5 (Cell)	10	24.0	22.90	0.13	1	Left	Cheek	QPSK	25	0	11456	1:1	0.035	1.288	0.045	
836.50	20525	Mid	LTE Band 5 (Cell)	10	25.0	24.02	0.17	0	Left	Tilt	QPSK	1	25	11456	1:1	0.029	1.253	0.036	
836.50	20525	Mid	LTE Band 5 (Cell)	10	24.0	22.90	0.17	1	Left	Tilt	QPSK	25	0	11456	1:1	0.021	1.288	0.027	
ANSI / IEEE C95.1 1992 - SAFETY LIMIT Spatial Peak Uncontrolled Exposure/General Population										Head 1.6 W/kg (mW/g) averaged over 1 gram									

FCC ID: A3LSMJ530F	 PCTEST ENGINEERING LABORATORY, INC.	<b>SAR EVALUATION REPORT</b>		Approved by: Quality Manager
Document S/N: 1M1703200117-01.A3L	Test Dates: 03/20/17 - 04/05/17	DUT Type: Portable Handset	Page 33 of 49	



**Table 11-7  
DTS Head SAR**

MEASUREMENT RESULTS																		
FREQUENCY		Mode	Service	Bandwidth [MHz]	Maximum Allowed Power [dBm]	Conducted Power [dBm]	Power Drift [dB]	Side	Test Position	Device Serial Number	Data Rate (Mbps)	Duty Cycle (%)	Peak SAR of Area Scan	SAR (1g)	Scaling Factor (Power)	Scaling Factor (Duty Cycle)	Reported SAR (1g)	Plot #
MHz	Ch.												W/kg	(W/kg)			(W/kg)	
2412	1	802.11b	DSSS	22	16.5	16.07	0.01	Right	Cheek	74852	1	99.8	0.764	0.652	1.104	1.002	0.721	
2412	1	802.11b	DSSS	22	16.5	16.07	0.00	Right	Tilt	74852	1	99.8	0.888	0.717	1.104	1.002	0.793	A7
2412	1	802.11b	DSSS	22	16.5	16.07	0.18	Left	Cheek	74852	1	99.8	0.520	-	1.104	1.002	-	
2412	1	802.11b	DSSS	22	16.5	16.07	0.05	Left	Tilt	74852	1	99.8	0.648	-	1.104	1.002	-	
ANSI / IEEE C95.1 1992 - SAFETY LIMIT Spatial Peak Uncontrolled Exposure/General Population										Head 1.6 W/kg (mW/g) averaged over 1 gram								

**Table 11-8  
NII Head SAR**

MEASUREMENT RESULTS																		
FREQUENCY		Mode	Service	Bandwidth [MHz]	Maximum Allowed Power [dBm]	Conducted Power [dBm]	Power Drift [dB]	Side	Test Position	Device Serial Number	Data Rate (Mbps)	Duty Cycle (%)	Peak SAR of Area Scan	SAR (1g)	Scaling Factor (Power)	Scaling Factor (Duty Cycle)	Reported SAR (1g)	Plot #
MHz	Ch.												W/kg	(W/kg)			(W/kg)	
5260	52	802.11a	OFDM	20	12.5	12.42	-0.12	Right	Cheek	19228	6	98.6	1.701	0.999	1.019	1.014	1.032	
5280	56	802.11a	OFDM	20	12.5	12.38	0.05	Right	Cheek	19228	6	98.6	1.757	0.991	1.028	1.014	1.033	
5260	52	802.11a	OFDM	20	12.5	12.42	-0.01	Right	Tilt	19228	6	98.6	1.460	0.818	1.019	1.014	0.845	
5280	56	802.11a	OFDM	20	12.5	12.38	0.16	Right	Tilt	19228	6	98.6	1.462	0.812	1.028	1.014	0.846	
5260	52	802.11a	OFDM	20	12.5	12.42	0.17	Left	Cheek	19228	6	98.6	1.093	-	1.019	1.014	-	
5260	52	802.11a	OFDM	20	12.5	12.42	0.03	Left	Tilt	19228	6	98.6	1.371	0.625	1.019	1.014	0.646	
5260	52	802.11a	OFDM	20	12.5	12.42	0.20	Right	Cheek	19228	6	98.6	1.626	1.010	1.019	1.014	1.044	A8
5500	100	802.11a	OFDM	20	12.5	12.39	0.07	Right	Cheek	19228	6	98.6	1.796	0.900	1.026	1.014	0.936	
5600	120	802.11a	OFDM	20	12.5	12.38	0.08	Right	Cheek	19228	6	98.6	1.776	0.913	1.028	1.014	0.952	
5500	100	802.11a	OFDM	20	12.5	12.39	-0.07	Right	Tilt	19228	6	98.6	2.069	0.771	1.026	1.014	0.802	
5600	120	802.11a	OFDM	20	12.5	12.38	0.13	Right	Tilt	19228	6	98.6	2.234	0.887	1.028	1.014	0.925	
5500	100	802.11a	OFDM	20	12.5	12.39	-0.01	Left	Cheek	19228	6	98.6	1.288	0.590	1.026	1.014	0.614	
5500	100	802.11a	OFDM	20	12.5	12.39	-0.05	Left	Tilt	19228	6	98.6	1.052	-	1.026	1.014	-	
5600	120	802.11a	OFDM	20	12.5	12.38	-0.03	Right	Cheek	19228	6	98.6	1.673	0.805	1.028	1.014	0.839	
5745	149	802.11a	OFDM	20	12.5	11.74	0.21	Right	Cheek	19228	6	98.6	2.166	0.733	1.191	1.014	0.885	
5825	165	802.11a	OFDM	20	12.5	11.66	0.12	Right	Cheek	19228	6	98.6	1.768	0.641	1.213	1.014	0.788	
5745	149	802.11a	OFDM	20	12.5	11.74	-0.11	Right	Tilt	19228	6	98.6	2.271	0.822	1.191	1.014	0.993	
5825	165	802.11a	OFDM	20	12.5	11.66	0.17	Right	Tilt	19228	6	98.6	1.872	0.656	1.213	1.014	0.807	
5745	149	802.11a	OFDM	20	12.5	11.74	0.07	Left	Cheek	19228	6	98.6	1.121	-	1.191	1.014	-	
5745	149	802.11a	OFDM	20	12.5	11.74	0.11	Left	Tilt	19228	6	98.6	1.134	0.426	1.191	1.014	0.514	
ANSI / IEEE C95.1 1992 - SAFETY LIMIT Spatial Peak Uncontrolled Exposure/General Population										Head 1.6 W/kg (mW/g) averaged over 1 gram								

Note: Blue Entries Represent Variability

FCC ID: A3LSMJ530F	 PCTEST ENGINEERING LABORATORY, INC.	<b>SAR EVALUATION REPORT</b>		<b>Approved by:</b> Quality Manager
Document S/N: 1M1703200117-01.A3L	Test Dates: 03/20/17 - 04/05/17	DUT Type: Portable Handset	Page 34 of 49	

## 11.2 Standalone Body-Worn SAR Data

**Table 11-9  
GSM/UMTS Body-Worn SAR Data**

MEASUREMENT RESULTS															
FREQUENCY		Mode	Service	Maximum Allowed Power [dBm]	Conducted Power [dBm]	Power Drift [dB]	Spacing	Device Serial Number	# of Time Slots	Duty Cycle	Side	SAR (1g)	Scaling Factor	Reported SAR (1g)	Plot #
MHz	Ch.											(W/kg)		(W/kg)	
836.60	190	GSM 850	GSM	33.5	32.74	0.03	15 mm	29760	1	1:8.3	back	0.172	1.191	0.205	A9
1880.00	661	GSM 1900	GSM	30.5	29.32	0.06	15 mm	29828	1	1:8.3	back	0.441	1.312	0.579	A11
836.60	4183	UMTS 850	RMC	23.8	23.77	-0.03	15 mm	29828	N/A	1:1	back	0.253	1.007	0.255	A13
1732.40	1412	UMTS 1750	RMC	23.5	22.96	0.03	15 mm	29828	N/A	1:1	back	0.457	1.132	0.517	A15
1852.40	9262	UMTS 1900	RMC	23.0	22.65	0.04	15 mm	29828	N/A	1:1	back	0.787	1.084	0.853	
1880.00	9400	UMTS 1900	RMC	23.0	22.77	0.02	15 mm	29828	N/A	1:1	back	0.695	1.054	0.733	
1907.60	9538	UMTS 1900	RMC	23.0	22.61	0.02	15 mm	29828	N/A	1:1	back	0.814	1.094	0.891	A17
ANSI / IEEE C95.1 1992 - SAFETY LIMIT Spatial Peak Uncontrolled Exposure/General Population										Body 1.6 W/kg (mW/g) averaged over 1 gram					

**Table 11-10  
LTE Body-Worn SAR**



MEASUREMENT RESULTS																			
FREQUENCY		Mode	Bandwidth [MHz]	Maximum Allowed Power [dBm]	Conducted Power [dBm]	Power Drift [dB]	MPR [dB]	Device Serial Number	Modulation	RB Size	RB Offset	Spacing	Side	Duty Cycle	SAR (1g)	Scaling Factor	Reported SAR (1g)	Plot #	
MHz	Ch.														(W/kg)		(W/kg)		
836.50	20525	Mid	LTE Band 5 (Cell)	10	25.0	24.02	-0.04	0	29828	QPSK	1	25	15 mm	back	1:1	0.311	1.253	0.390	A19
836.50	20525	Mid	LTE Band 5 (Cell)	10	24.0	22.90	0.04	1	29828	QPSK	25	0	15 mm	back	1:1	0.236	1.288	0.304	
ANSI / IEEE C95.1 1992 - SAFETY LIMIT Spatial Peak Uncontrolled Exposure/General Population										Body 1.6 W/kg (mW/g) averaged over 1 gram									

**Table 11-11  
DTS Body-Worn SAR**

MEASUREMENT RESULTS																		
FREQUENCY		Mode	Service	Bandwidth [MHz]	Maximum Allowed Power [dBm]	Conducted Power [dBm]	Power Drift [dB]	Spacing	Device Serial Number	Data Rate (Mbps)	Side	Duty Cycle (%)	Peak SAR of Area Scan	SAR (1g)	Scaling Factor (Power)	Scaling Factor (Duty Cycle)	Reported SAR (1g)	Plot #
MHz	Ch.												(W/kg)	(W/kg)		(W/kg)	(W/kg)	
2437	6	802.11b	DSSS	22	18.5	18.04	0.11	15 mm	29752	1	back	99.8	0.166	0.112	1.112	1.002	0.125	A21
ANSI / IEEE C95.1 1992 - SAFETY LIMIT Spatial Peak Uncontrolled Exposure/General Population										Body 1.6 W/kg (mW/g) averaged over 1 gram								

**Table 11-12  
NII Body-Worn SAR**

MEASUREMENT RESULTS																		
FREQUENCY		Mode	Service	Bandwidth [MHz]	Maximum Allowed Power [dBm]	Conducted Power [dBm]	Power Drift [dB]	Spacing	Device Serial Number	Data Rate (Mbps)	Side	Duty Cycle (%)	Peak SAR of Area Scan	SAR (1g)	Scaling Factor (Power)	Scaling Factor (Duty Cycle)	Reported SAR (1g)	Plot #
MHz	Ch.												(W/kg)	(W/kg)		(W/kg)	(W/kg)	
5260	52	802.11a	OFDM	20	14.5	14.23	0.20	15 mm	74902	6	back	98.6	0.090	0.044	1.064	1.014	0.047	
5500	100	802.11a	OFDM	20	14.5	14.08	-0.11	15 mm	74902	6	back	98.6	0.125	0.059	1.102	1.014	0.066	
5745	149	802.11a	OFDM	20	14.5	14.21	0.12	15 mm	74902	6	back	98.6	0.140	0.069	1.069	1.014	0.075	A23
ANSI / IEEE C95.1 1992 - SAFETY LIMIT Spatial Peak Uncontrolled Exposure/General Population										Body 1.6 W/kg (mW/g) averaged over 1 gram								



FCC ID: A3LSMJ530F		SAR EVALUATION REPORT		Approved by: Quality Manager
Document S/N: 1M1703200117-01.A3L	Test Dates: 03/20/17 - 04/05/17	DUT Type: Portable Handset		Page 35 of 49

# 11.3 Standalone Hotspot SAR Data

**Table 11-13  
GPRS/UMTS Hotspot SAR Data**

MEASUREMENT RESULTS															
FREQUENCY		Mode	Service	Maximum Allowed Power [dBm]	Conducted Power [dBm]	Power Drift [dB]	Spacing	Device Serial Number	# of GPRS Slots	Duty Cycle	Side	SAR (1g)	Scaling Factor	Reported SAR (1g)	Plot #
MHz	Ch.											(W/kg)		(W/kg)	
836.60	190	GSM 850	GPRS	28.5	27.78	-0.03	10 mm	29760	3	1:2.76	back	0.166	1.180	0.196	A10
836.60	190	GSM 850	GPRS	28.5	27.78	-0.04	10 mm	29760	3	1:2.76	front	0.116	1.180	0.137	
836.60	190	GSM 850	GPRS	28.5	27.78	0.09	10 mm	29760	3	1:2.76	bottom	0.047	1.180	0.055	
836.60	190	GSM 850	GPRS	28.5	27.78	0.01	10 mm	29760	3	1:2.76	right	0.098	1.180	0.116	
836.60	190	GSM 850	GPRS	28.5	27.78	-0.02	10 mm	29760	3	1:2.76	left	0.043	1.180	0.051	
1850.20	512	GSM 1900	GPRS	23.0	23.00	0.00	10 mm	29828	4	1:2.076	back	0.452	1.000	0.452	
1850.20	512	GSM 1900	GPRS	23.0	23.00	0.03	10 mm	29828	4	1:2.076	front	0.323	1.000	0.323	
1850.20	512	GSM 1900	GPRS	23.0	23.00	0.15	10 mm	29828	4	1:2.076	bottom	0.495	1.000	0.495	A12
1850.20	512	GSM 1900	GPRS	23.0	23.00	-0.03	10 mm	29828	4	1:2.076	right	0.057	1.000	0.057	
1850.20	512	GSM 1900	GPRS	23.0	23.00	-0.02	10 mm	29828	4	1:2.076	left	0.053	1.000	0.053	
836.60	4183	UMTS 850	RMC	23.8	23.77	-0.05	10 mm	29828	N/A	1:1	back	0.359	1.007	0.362	A14
836.60	4183	UMTS 850	RMC	23.8	23.77	0.05	10 mm	29828	N/A	1:1	front	0.244	1.007	0.246	
836.60	4183	UMTS 850	RMC	23.8	23.77	-0.01	10 mm	29828	N/A	1:1	bottom	0.099	1.007	0.100	
836.60	4183	UMTS 850	RMC	23.8	23.77	0.04	10 mm	29828	N/A	1:1	right	0.170	1.007	0.171	
836.60	4183	UMTS 850	RMC	23.8	23.77	0.03	10 mm	29828	N/A	1:1	left	0.058	1.007	0.058	
1732.40	1412	UMTS 1750	RMC	19.5	19.30	-0.04	10 mm	29828	N/A	1:1	back	0.653	1.047	0.684	A16
1732.40	1412	UMTS 1750	RMC	19.5	19.30	-0.04	10 mm	29828	N/A	1:1	front	0.480	1.047	0.503	
1732.40	1412	UMTS 1750	RMC	19.5	19.30	0.01	10 mm	29828	N/A	1:1	bottom	0.632	1.047	0.662	
1732.40	1412	UMTS 1750	RMC	19.5	19.30	-0.04	10 mm	29828	N/A	1:1	right	0.064	1.047	0.067	
1732.40	1412	UMTS 1750	RMC	19.5	19.30	0.03	10 mm	29828	N/A	1:1	left	0.115	1.047	0.120	
1852.40	9262	UMTS 1900	RMC	20.5	19.88	-0.07	10 mm	29828	N/A	1:1	back	0.831	1.153	0.958	A18
1880.00	9400	UMTS 1900	RMC	20.5	19.17	0.06	10 mm	29828	N/A	1:1	back	0.728	1.358	0.989	
1907.60	9538	UMTS 1900	RMC	20.5	19.60	0.12	10 mm	29828	N/A	1:1	back	0.824	1.230	1.014	
1852.40	9262	UMTS 1900	RMC	20.5	19.88	0.02	10 mm	29828	N/A	1:1	front	0.511	1.153	0.589	
1852.40	9262	UMTS 1900	RMC	20.5	19.88	0.00	10 mm	29828	N/A	1:1	bottom	0.826	1.153	0.952	
1880.00	9400	UMTS 1900	RMC	20.5	19.17	-0.09	10 mm	29828	N/A	1:1	bottom	0.715	1.358	0.971	
1907.60	9538	UMTS 1900	RMC	20.5	19.60	-0.08	10 mm	29828	N/A	1:1	bottom	0.757	1.230	0.931	
1852.40	9262	UMTS 1900	RMC	20.5	19.88	-0.11	10 mm	29828	N/A	1:1	right	0.117	1.153	0.135	
1852.40	9262	UMTS 1900	RMC	20.5	19.88	0.00	10 mm	29828	N/A	1:1	left	0.104	1.153	0.120	
1852.40	9262	UMTS 1900	RMC	20.5	19.88	-0.01	10 mm	29828	N/A	1:1	back	0.770	1.153	0.888	
ANSI / IEEE C95.1 1992 - SAFETY LIMIT Spatial Peak Uncontrolled Exposure/General Population								Body 1.6 W/kg (mW/g) averaged over 1 gram							

Note: Blue Entry Represents Variability

FCC ID: A3LSMJ530F		SAR EVALUATION REPORT		Approved by: Quality Manager
Document S/N: 1M1703200117-01.A3L	Test Dates: 03/20/17 - 04/05/17	DUT Type: Portable Handset	Page 36 of 49	



**Table 11-14  
LTE Band 5 (Cell) Hotspot SAR**

MEASUREMENT RESULTS																			
FREQUENCY		Mode	Bandwidth [MHz]	Maximum Allowed Power [dBm]	Conducted Power [dBm]	Power Drift [dB]	MPR [dB]	Device Serial Number	Modulation	RB Size	RB Offset	Spacing	Side	Duty Cycle	SAR (1g)	Scaling Factor	Reported SAR (1g)	Plot #	
MHz	Ch.														(W/kg)		(W/kg)		
836.50	20525	Mid	LTE Band 5 (Cell)	10	25.0	24.02	-0.05	0	29828	QPSK	1	25	10 mm	back	1:1	0.390	1.253	0.489	A20
836.50	20525	Mid	LTE Band 5 (Cell)	10	24.0	22.90	-0.01	1	29828	QPSK	25	0	10 mm	back	1:1	0.296	1.288	0.381	
836.50	20525	Mid	LTE Band 5 (Cell)	10	25.0	24.02	0.03	0	29828	QPSK	1	25	10 mm	front	1:1	0.272	1.253	0.341	
836.50	20525	Mid	LTE Band 5 (Cell)	10	24.0	22.90	0.02	1	29828	QPSK	25	0	10 mm	front	1:1	0.209	1.288	0.269	
836.50	20525	Mid	LTE Band 5 (Cell)	10	25.0	24.02	-0.02	0	29828	QPSK	1	25	10 mm	bottom	1:1	0.115	1.253	0.144	
836.50	20525	Mid	LTE Band 5 (Cell)	10	24.0	22.90	0.02	1	29828	QPSK	25	0	10 mm	bottom	1:1	0.087	1.288	0.112	
836.50	20525	Mid	LTE Band 5 (Cell)	10	25.0	24.02	0.02	0	29828	QPSK	1	25	10 mm	right	1:1	0.278	1.253	0.348	
836.50	20525	Mid	LTE Band 5 (Cell)	10	24.0	22.90	0.03	1	29828	QPSK	25	0	10 mm	right	1:1	0.206	1.288	0.265	
836.50	20525	Mid	LTE Band 5 (Cell)	10	25.0	24.02	0.01	0	29828	QPSK	1	25	10 mm	left	1:1	0.117	1.253	0.147	
836.50	20525	Mid	LTE Band 5 (Cell)	10	24.0	22.90	-0.03	1	29828	QPSK	25	0	10 mm	left	1:1	0.084	1.288	0.108	
ANSI / IEEE C95.1 1992 - SAFETY LIMIT Spatial Peak Uncontrolled Exposure/General Population										Body 1.6 W/kg (mW/g) averaged over 1 gram									

**Table 11-15  
WLAN Hotspot SAR**

MEASUREMENT RESULTS																		
FREQUENCY		Mode	Service	Bandwidth [MHz]	Maximum Allowed Power [dBm]	Conducted Power [dBm]	Power Drift [dB]	Spacing	Device Serial Number	Data Rate (Mbps)	Side	Duty Cycle (%)	Peak SAR of Area Scan	SAR (1g)	Scaling Factor (Power)	Scaling Factor (Duty Cycle)	Reported SAR (1g)	Plot #
MHz	Ch.												(W/kg)	(W/kg)			(W/kg)	
2437	6	802.11b	DSSS	22	18.5	18.04	0.04	10 mm	29752	1	back	99.8	0.346	-	1.112	1.002	-	
2437	6	802.11b	DSSS	22	18.5	18.04	-0.12	10 mm	29752	1	front	99.8	0.271	-	1.112	1.002	-	
2437	6	802.11b	DSSS	22	18.5	18.04	0.10	10 mm	29752	1	top	99.8	0.378	0.244	1.112	1.002	0.272	A22
2437	6	802.11b	DSSS	22	18.5	18.04	0.16	10 mm	29752	1	right	99.8	0.021	-	1.112	1.002	-	
2437	6	802.11b	DSSS	22	18.5	18.04	0.15	10 mm	29752	1	left	99.8	0.038	-	1.112	1.002	-	
5745	149	802.11a	OFDM	20	14.5	14.21	-0.13	10 mm	74902	6	back	98.6	0.236	0.133	1.069	1.014	0.144	
5745	149	802.11a	OFDM	20	14.5	14.21	0.13	10 mm	74902	6	front	98.6	1.544	0.828	1.069	1.014	0.898	A24
5785	157	802.11a	OFDM	20	14.5	14.08	0.14	10 mm	74902	6	front	98.6	1.577	0.783	1.102	1.014	0.875	
5745	149	802.11a	OFDM	20	14.5	14.21	0.12	10 mm	74902	6	top	98.6	0.831	0.386	1.069	1.014	0.418	
5745	149	802.11a	OFDM	20	14.5	14.21	-0.20	10 mm	74902	6	right	98.6	0.102	-	1.069	1.014	-	
5745	149	802.11a	OFDM	20	14.5	14.21	0.18	10 mm	74902	6	left	98.6	0.186	-	1.069	1.014	-	
5745	149	802.11a	OFDM	20	14.5	14.21	0.17	10 mm	74902	6	front	98.6	1.581	0.777	1.069	1.014	0.842	
ANSI / IEEE C95.1 1992 - SAFETY LIMIT Spatial Peak Uncontrolled Exposure/General Population										Body 1.6 W/kg (mW/g) averaged over 1 gram								

Note: Blue Entry Represents Variability

FCC ID: A3LSMJ530F	 PCTEST ENGINEERING LABORATORY, INC.	<b>SAR EVALUATION REPORT</b>		<b>Approved by:</b> Quality Manager
Document S/N: 1M1703200117-01.A3L	Test Dates: 03/20/17 - 04/05/17	DUT Type: Portable Handset		Page 37 of 49

## 11.4 SAR Test Notes

### General Notes:

1. The test data reported are the worst-case SAR values according to test procedures specified in IEEE 1528-2013, and FCC KDB Publication 447498 D01v06.
2. Batteries are fully charged at the beginning of the SAR measurements.
3. Liquid tissue depth was at least 15.0 cm for all frequencies.
4. The manufacturer has confirmed that the device(s) tested have the same physical, mechanical and thermal characteristics and are within operational tolerances expected for production units.
5. SAR results were scaled to the maximum allowed power to demonstrate compliance per FCC KDB Publication 447498 D01v06.
6. Device was tested using a fixed spacing for body-worn accessory testing. A separation distance of 15 mm was considered because the manufacturer has determined that there will be body-worn accessories available in the marketplace for users to support this separation distance.
7. Per FCC KDB Publication 648474 D04v01r03, body-worn SAR was evaluated without a headset connected to the device. Since the standalone reported body-worn SAR was  $\leq 1.2$  W/kg, no additional body-worn SAR evaluations using a headset cable were required.
8. Per FCC KDB 865664 D01v01r04, variability SAR tests were performed when the measured SAR results for a frequency band were greater than or equal to 0.8 W/kg. Repeated SAR measurements are highlighted in the tables above for clarity. Please see Section 13 for variability analysis.
9. During SAR Testing for the Wireless Router conditions per FCC KDB Publication 941225 D06v02r01, the actual Portable Hotspot operation (with actual simultaneous transmission of a transmitter with WIFI) was not activated (See Section 6.7 for more details).

### GSM Test Notes:



1. Body-Worn accessory testing is typically associated with voice operations. Therefore, GSM voice was evaluated for body-worn SAR.
2. Justification for reduced test configurations per KDB Publication 941225 D01v03r01 and October 2013 TCB Workshop Notes: The source-based frame-averaged output power was evaluated for all GPRS/EDGE slot configurations. The configuration with the highest target frame averaged output power was evaluated for hotspot SAR. When the maximum frame-averaged powers are equivalent across two or more slots (within 0.25 dB), the configuration with the most number of time slots was tested.
3. Per FCC KDB Publication 447498 D01v06, if the reported (scaled) SAR measured at the middle channel or highest output power channel for each test configuration is  $\leq 0.8$  W/kg then testing at the other channels is not required for such test configuration(s). When the maximum output power variation across the required test channels is  $> \frac{1}{2}$  dB, instead of the middle channel, the highest output power channel was used.

### UMTS Notes:

1. UMTS mode in was tested under RMC 12.2 kbps with HSPA Inactive per KDB Publication 941225 D01v03r01. AMR and HSPA SAR was not required per the 3G Test Reduction Procedure in KDB Publication 941225 D01v03r01.
2. Per FCC KDB Publication 447498 D01v06, if the reported (scaled) SAR measured at the middle channel or highest output power channel for each test configuration is  $\leq 0.8$  W/kg then testing at the other channels is not required for such test configuration(s). When the maximum output power variation across the required test channels is  $> \frac{1}{2}$  dB, instead of the middle channel, the highest output power channel was used.

### LTE Notes:



1. LTE Considerations: LTE test configurations are determined according to SAR Evaluation Considerations for LTE Devices in FCC KDB Publication 941225 D05v02r04. The general test procedures used for testing can be found in Section 8.5.4.

<b>FCC ID:</b> A3LSMJ530F		<b>SAR EVALUATION REPORT</b>		<b>Approved by:</b> Quality Manager
<b>Document S/N:</b> 1M1703200117-01.A3L	<b>Test Dates:</b> 03/20/17 - 04/05/17	<b>DUT Type:</b> Portable Handset	Page 38 of 49	

2. MPR is permanently implemented for this device by the manufacturer. The specific manufacturer target MPR is indicated alongside the SAR results. MPR is enabled for this device, according to 3GPP TS36.101 Section 6.2.3 – 6.2.5 under Table 6.2.3-1.
3. A-MPR was disabled for all SAR tests by setting NS=01 on the base station simulator. SAR tests were performed with the same number of RB and RB offsets transmitting on all TTI frames (maximum TTI).

**WLAN Notes:**

1. For held-to-ear and hotspot operations, the initial test position procedures were applied. The test position with the highest extrapolated peak SAR will be used as the initial test position. When reported SAR for the initial test position is  $\leq 0.4$  W/kg, no additional testing for the remaining test positions was required. Otherwise, SAR is evaluated at the subsequent highest peak SAR positions until the reported SAR result is  $\leq 0.8$  W/kg or all test positions are measured.
2. Justification for test configurations for WLAN per KDB Publication 248227 D01v02r02 for 2.4 GHz WIFI operations, the highest measured maximum output power channel for DSSS was selected for SAR measurement. SAR for OFDM modes (2.4 GHz 802.11g/n) was not required due to the maximum allowed powers and the highest reported DSSS SAR. See Section 8.6.5 for more information.
3. Justification for test configurations for WLAN per KDB Publication 248227 D01v02r02 for 5 GHz WIFI operations, the initial test configuration was selected according to the transmission mode with the highest maximum allowed powers. Other transmission modes were not investigated since the highest reported SAR for initial test configuration adjusted by the ratio of maximum output powers is less than 1.2 W/kg. See Section 8.6.6 for more information.
4. When the maximum reported 1g averaged SAR is  $\leq 0.8$  W/kg, SAR testing on additional channels was not required. Otherwise, SAR for the next highest output power channel was required until the reported SAR result was  $\leq 1.20$  W/kg or all test channels were measured.
5. The device was configured to transmit continuously at the required data rate, channel bandwidth and signal modulation, using the highest transmission duty factor supported by the test mode tools. The reported SAR was scaled to the 100% transmission duty factor to determine compliance. Procedures used to measure the duty factor are identical to that in the associated EMC test reports.

<b>FCC ID:</b> A3LSMJ530F	 <b>SAR EVALUATION REPORT</b> 		<b>Approved by:</b> Quality Manager
<b>Document S/N:</b> 1M1703200117-01.A3L	<b>Test Dates:</b> 03/20/17 - 04/05/17	<b>DUT Type:</b> Portable Handset	Page 39 of 49

# 12 FCC MULTI-TX AND ANTENNA SAR CONSIDERATIONS

## 12.1 Introduction

The following procedures adopted from FCC KDB Publication 447498 D01v06 are applicable to devices with built-in unlicensed transmitters such as 802.11 and Bluetooth devices which may simultaneously transmit with the licensed transmitter.

## 12.2 Simultaneous Transmission Procedures

This device contains transmitters that may operate simultaneously. Therefore simultaneous transmission analysis is required. Per FCC KDB Publication 447498 D01v06 4.3.2 and IEEE 1528-2013 Section 6.3.4.1.2, simultaneous transmission SAR test exclusion may be applied when the sum of the 1-g SAR for all the simultaneous transmitting antennas in a specific a physical test configuration is  $\leq 1.6$  W/kg. The different test positions in an exposure condition may be considered collectively to determine SAR test exclusion according to the sum of 1-g or 10-g SAR.



When standalone SAR is not required to be measured, per FCC KDB 447498 D01v06 4.3.2 b), the following equation must be used to estimate the standalone 1g SAR for simultaneous transmission assessment involving that transmitter.

$$\text{Estimated SAR} = \frac{\sqrt{f(\text{GHz})}}{7.5} * \frac{(\text{Max Power of channel, mW})}{\text{Min. Separation Distance, mm}}$$

**Table 12-1  
Estimated SAR**

Mode	Frequency	Maximum Allowed Power	Separation Distance (Body)	Estimated SAR (Body)
	[MHz]	[dBm]	[mm]	[W/kg]
Bluetooth	2480	9.50	15	0.126

Note: Held-to ear configurations are not applicable to Bluetooth operations and therefore were not considered for simultaneous transmission. Per KDB Publication 447498 D01v06, the maximum power of the channel was rounded to the nearest mW before calculation.

FCC ID: A3LSMJ530F	 <b>PCTEST</b> ENGINEERING LABORATORY, INC.	<b>SAR EVALUATION REPORT</b>		<b>Approved by:</b> Quality Manager
Document S/N: 1M1703200117-01.A3L	Test Dates: 03/20/17 - 04/05/17	DUT Type: Portable Handset		Page 40 of 49

## 12.3 Head SAR Simultaneous Transmission Analysis

**Table 12-2**  
**Simultaneous Transmission Scenario with 2.4 GHz WLAN (Held to Ear)**

Exposure Condition	Mode	2G/3G/4G SAR (W/kg)	2.4 GHz WLAN SAR (W/kg)	$\Sigma$ SAR (W/kg)
Head SAR	GSM 850	0.044	0.793	0.837
	GSM 1900	0.076	0.793	0.869
	UMTS 850	0.108	0.793	0.901
	UMTS 1750	0.089	0.793	0.882
	UMTS 1900	0.123	0.793	<b>0.916</b>
	LTE Band 5 (Cell)	0.059	0.793	0.852



**Table 12-3**  
**Simultaneous Transmission Scenario with 5 GHz WLAN (Held to Ear)**

Exposure Condition	Mode	2G/3G/4G SAR (W/kg)	5 GHz WLAN SAR (W/kg)	$\Sigma$ SAR (W/kg)
Head SAR	GSM 850	0.044	1.044	1.088
	GSM 1900	0.076	1.044	1.120
	UMTS 850	0.108	1.044	1.152
	UMTS 1750	0.089	1.044	1.133
	UMTS 1900	0.123	1.044	<b>1.167</b>
	LTE Band 5 (Cell)	0.059	1.044	1.103

## 12.4 Body-Worn Simultaneous Transmission Analysis

**Table 12-4**  
**Simultaneous Transmission Scenario with 2.4 GHz WLAN (Body-Worn at 1.5 cm)**

Exposure Condition	Mode	2G/3G/4G SAR (W/kg)	2.4 GHz WLAN SAR (W/kg)	$\Sigma$ SAR (W/kg)
Body-Worn	GSM 850	0.205	0.125	0.330
	GSM 1900	0.579	0.125	0.704
	UMTS 850	0.255	0.125	0.380
	UMTS 1750	0.517	0.125	0.642
	UMTS 1900	0.891	0.125	<b>1.016</b>
	LTE Band 5 (Cell)	0.390	0.125	0.515

FCC ID: A3LSMJ530F	 <b>PCTEST</b> ENGINEERING LABORATORY, INC.	<b>SAR EVALUATION REPORT</b>		<b>Approved by:</b> Quality Manager
Document S/N: 1M1703200117-01.A3L	Test Dates: 03/20/17 - 04/05/17	DUT Type: Portable Handset		Page 41 of 49

**Table 12-5**  
**Simultaneous Transmission Scenario with 5 GHz WLAN (Body-Worn at 1.5 cm)**

Exposure Condition	Mode	2G/3G/4G SAR (W/kg)	5 GHz WLAN SAR (W/kg)	Σ SAR (W/kg)
Body-Worn	GSM 850	0.205	0.075	0.280
	GSM 1900	0.579	0.075	0.654
	UMTS 850	0.255	0.075	0.330
	UMTS 1750	0.517	0.075	0.592
	UMTS 1900	0.891	0.075	<b>0.966</b>
	LTE Band 5 (Cell)	0.390	0.075	0.465

**Table 12-6**  
**Simultaneous Transmission Scenario with Bluetooth (Body-Worn at 1.5 cm)**



Exposure Condition	Mode	2G/3G/4G SAR (W/kg)	Bluetooth SAR (W/kg)	Σ SAR (W/kg)
Body-Worn	GSM 850	0.205	0.126	0.331
	GSM 1900	0.579	0.126	0.705
	UMTS 850	0.255	0.126	0.381
	UMTS 1750	0.517	0.126	0.643
	UMTS 1900	0.891	0.126	<b>1.017</b>
	LTE Band 5 (Cell)	0.390	0.126	0.516

Note: Bluetooth SAR was not required to be measured per FCC KDB 447498. Estimated SAR results were used in the above table to determine simultaneous transmission SAR test exclusion.

## 12.5 Hotspot SAR Simultaneous Transmission Analysis

**Table 12-7**  
**Simultaneous Transmission Scenario (2.4 GHz Hotspot at 1.0 cm)**

Exposure Condition	Mode	2G/3G/4G SAR (W/kg)	2.4 GHz WLAN SAR (W/kg)	Σ SAR (W/kg)
Hotspot SAR	GPRS 850	0.196	0.272	0.468
	GPRS 1900	0.495	0.272	0.767
	UMTS 850	0.362	0.272	0.634
	UMTS 1750	0.684	0.272	0.956
	UMTS 1900	1.014	0.272	<b>1.286</b>
	LTE Band 5 (Cell)	0.489	0.272	0.761

FCC ID: A3LSMJ530F		SAR EVALUATION REPORT		Approved by: Quality Manager
Document S/N: 1M1703200117-01.A3L	Test Dates: 03/20/17 - 04/05/17	DUT Type: Portable Handset		Page 42 of 49

**Table 12-8  
Simultaneous Transmission Scenario with 5 GHz WLAN (Hotspot at 1.0 cm)**

Exposure Condition	Mode	2G/3G/4G SAR (W/kg)	5 GHz WLAN SAR (W/kg)	Σ SAR (W/kg)
Hotspot SAR	GPRS 850	0.196	0.898	1.094
	GPRS 1900	0.495	0.898	1.393
	UMTS 850	0.362	0.898	1.260
	UMTS 1750	0.684	0.898	<b>1.582</b>
	UMTS 1900	1.014	0.898	See Table Below
	LTE Band 5 (Cell)	0.489	0.898	1.387



Simult Tx	Configuration	UMTS 1900 SAR (W/kg)	5 GHz WLAN SAR (W/kg)	Σ SAR (W/kg)
Hotspot SAR	Back	1.014	0.144	1.158
	Front	0.589	0.898	<b>1.487</b>
	Top	-	0.418	0.418
	Bottom	0.971	-	0.971
	Right	0.135	0.898*	1.033
	Left	0.120	0.898*	1.018

Notes:

- (\*) For test positions that were not required to be evaluated for WLAN SAR per FCC KDB publication 248227, the worst case WLAN SAR result for applicable exposure conditions was used for simultaneous transmission analysis.
- Per FCC KDB Publication 941225 D06v02r01, the devices edges with antennas more than 2.5 cm from edge are not required to be evaluated for SAR (“-”).

**12.6 Simultaneous Transmission Conclusion**

The above numerical summed SAR results for all the worst-case simultaneous transmission conditions were below the SAR limit. Therefore, the above analysis is sufficient to determine that simultaneous transmission cases will not exceed the SAR limit and therefore no measured volumetric simultaneous SAR summation is required per FCC KDB Publication 447498 D01v06 and IEEE 1528-2013 Section 6.3.4.1.2.

FCC ID: A3LSMJ530F	 <b>PCTEST</b> ENGINEERING LABORATORY, INC.	<b>SAR EVALUATION REPORT</b>		<b>Approved by:</b> Quality Manager
Document S/N: 1M1703200117-01.A3L	Test Dates: 03/20/17 - 04/05/17	DUT Type: Portable Handset		Page 43 of 49

# 13 SAR MEASUREMENT VARIABILITY

## 13.1 Measurement Variability

Per FCC KDB Publication 865664 D01v01r04, SAR measurement variability was assessed for each frequency band, which was determined by the SAR probe calibration point and tissue-equivalent medium used for the device measurements. When both head and body tissue-equivalent media were required for SAR measurements in a frequency band, the variability measurement procedures were applied to the tissue medium with the highest measured SAR, using the highest measured SAR configuration for that tissue-equivalent medium. These additional measurements were repeated after the completion of all measurements requiring the same head or body tissue-equivalent medium in a frequency band. The test device was returned to ambient conditions (normal room temperature) with the battery fully charged before it was re-mounted on the device holder for the repeated measurement(s) to minimize any unexpected variations in the repeated results.

SAR Measurement Variability was assessed using the following procedures for each frequency band:

- 1) When the original highest measured SAR is  $\geq 0.80$  W/kg, the measurement was repeated once.
- 2) A second repeated measurement was performed only if the ratio of largest to smallest SAR for the original and first repeated measurements was  $> 1.20$  or when the original or repeated measurement was  $\geq 1.45$  W/kg (~ 10% from the 1-g SAR limit).
- 3) A third repeated measurement was performed only if the original, first or second repeated measurement was  $\geq 1.5$  W/kg and the ratio of largest to smallest SAR for the original, first and second repeated measurements is  $> 1.20$ .
- 4) Repeated measurements are not required when the original highest measured SAR is  $< 0.80$  W/kg

**Table 13-1  
Head SAR Measurement Variability Results**



HEAD VARIABILITY RESULTS														
Band	FREQUENCY		Mode/Band	Service	Side	Test Position	Data Rate (Mbps)	Measured SAR (1g)	1st Repeated SAR (1g)	Ratio	2nd Repeated SAR (1g)	Ratio	3rd Repeated SAR (1g)	Ratio
	MHz	Ch.						(W/kg)	(W/kg)		(W/kg)		(W/kg)	
5250	5260.00	52	802.11a, 20 MHz Bandwidth	OFDM	Right	Cheek	6	0.999	1.010	1.01	N/A	N/A	N/A	N/A
5600	5600.00	120	802.11a, 20 MHz Bandwidth	OFDM	Right	Cheek	6	0.913	0.805	1.13	N/A	N/A	N/A	N/A
ANSI / IEEE C95.1 1992 - SAFETY LIMIT Spatial Peak Uncontrolled Exposure/General Population								Head 1.6 W/kg (mW/g) averaged over 1 gram						

**Table 13-2  
Body SAR Measurement Variability Results**

BODY VARIABILITY RESULTS														
Band	FREQUENCY		Mode	Service	Data Rate (Mbps)	Side	Spacing	Measured SAR (1g)	1st Repeated SAR (1g)	Ratio	2nd Repeated SAR (1g)	Ratio	3rd Repeated SAR (1g)	Ratio
	MHz	Ch.						(W/kg)	(W/kg)		(W/kg)		(W/kg)	
1900	1852.40	9262	UMTS 1900	RMC	N/A	back	10 mm	0.831	0.770	1.08	N/A	N/A	N/A	N/A
5750	5745.00	149	802.11a, 20 MHz Bandwidth	OFDM	6	front	10 mm	0.828	0.777	1.07	N/A	N/A	N/A	N/A
ANSI / IEEE C95.1 1992 - SAFETY LIMIT Spatial Peak Uncontrolled Exposure/General Population								Body 1.6 W/kg (mW/g) averaged over 1 gram						

## 13.2 Measurement Uncertainty



The measured SAR was  $< 1.5$  W/kg for all frequency bands. Therefore, per KDB Publication 865664 D01v01r04, the extended measurement uncertainty analysis per IEEE 1528-2013 was not required.

FCC ID: A3LSMJ530F	 PCTEST ENGINEERING LABORATORY, INC.	SAR EVALUATION REPORT		Approved by: Quality Manager
Document S/N: 1M1703200117-01.A3L	Test Dates: 03/20/17 - 04/05/17	DUT Type: Portable Handset	Page 44 of 49	

# 14 EQUIPMENT LIST



Manufacturer	Model	Description	Cal Date	Cal Interval	Cal Due	Serial Number
Agilent	E5515C	8960 Series 10 Wireless Communications Test Set	10/5/2016	Annual	10/5/2017	GB42230325
Agilent	N9020A	MXA Signal Analyzer	10/28/2016	Annual	10/28/2017	US46470561
Agilent	N5182A	MXG Vector Signal Generator	10/27/2016	Annual	10/27/2017	MY47420603
Agilent	8753ES	S-Parameter Network Analyzer	10/26/2016	Annual	10/26/2017	US39170118
Agilent	8753ES	S-Parameter Vector Network Analyzer	8/19/2016	Annual	8/19/2017	MY40003841
Agilent	E5515C	Wireless Communications Test Set	1/29/2016	Biennial	1/29/2018	GB46310798
Amplifier Research	15S1G6	Amplifier	CBT	N/A	CBT	433978
Anritsu	ML2495A	Power Meter	10/16/2015	Biennial	10/16/2017	941001
Anritsu	ML2495A	Power Meter	10/16/2015	Biennial	10/16/2017	1039008
Anritsu	MA2411B	Pulse Power Sensor	2/10/2017	Annual	2/10/2018	1207364
Anritsu	MA2411B	Pulse Power Sensor	2/10/2017	Annual	2/10/2018	1339018
Anritsu	MT8820C	Radio Communication Analyzer	4/14/2016	Annual	4/14/2017	6201240328
Anritsu	MA24106A	USB Power Sensor	10/27/2016	Annual	10/27/2017	1349503
Anritsu	MA24106A	USB Power Sensor	10/27/2016	Annual	10/27/2017	1349509
COMTECH	AR85729-5/5759B	Solid State Amplifier	CBT	N/A	CBT	M3W1A00-1002
Control Company	4352	Ultra Long Stem Thermometer	3/8/2016	Biennial	3/8/2018	160261701
Keysight	772D	Dual Directional Coupler	CBT	N/A	CBT	MY52180215
MCL	BW-N6W5+	6dB Attenuator	CBT	N/A	CBT	1139
MiniCircuits	VLF-6000+	Low Pass Filter	CBT	N/A	CBT	N/A
MiniCircuits	SLP-2400+	Low Pass Filter	CBT	N/A	CBT	R8979500903
Mini-Circuits	BW-N20W5+	DC to 18 GHz Precision Fixed 20 dB Attenuator	CBT	N/A	CBT	N/A
Mini-Circuits	NLP-1200+	Low Pass Filter DC to 1000 MHz	CBT	N/A	CBT	N/A
Mini-Circuits	NLP-2950+	Low Pass Filter DC to 2700 MHz	CBT	N/A	CBT	N/A
Mini-Circuits	BW-N20W5	Power Attenuator	CBT	N/A	CBT	1226
Mitutoyo	CD-6"CSX	Digital Caliper	3/2/2016	Biennial	3/2/2018	13264165
Narda	4014C-6	4 - 8 GHz SMA 6 dB Directional Coupler	CBT	N/A	CBT	N/A
Narda	4772-3	Attenuator (3dB)	CBT	N/A	CBT	9406
Pasternack	PE2208-6	Bidirectional Coupler	CBT	N/A	CBT	N/A
Pasternack	PE2209-10	Bidirectional Coupler	CBT	N/A	CBT	N/A
Pasternack	NC-100	Torque Wrench	5/21/2015	Biennial	5/21/2017	N/A
Rohde & Schwarz	CMU200	Base Station Simulator	12/12/2016	Annual	12/12/2017	833855/0010
Rohde & Schwarz	CMW500	Radio Communication Tester	10/20/2016	Annual	10/20/2017	100976
Rohde & Schwarz	CMW500	Wideband Radio Communication Tester	7/20/2016	Annual	7/20/2017	132885
Seekonk	NC-100	Torque Wrench (8" lb)	9/1/2016	Biennial	9/1/2018	21053
SPEAG	D835V2	835 MHz SAR Dipole	7/13/2016	Annual	7/13/2017	4d047
SPEAG	D1765V2	1765 MHz SAR Dipole	5/11/2016	Annual	5/11/2017	1008
SPEAG	D1900V2	1900 MHz SAR Dipole	7/8/2016	Annual	7/8/2017	5d080
SPEAG	D1900V2	1900 MHz SAR Dipole	7/15/2016	Annual	7/15/2017	5d149
SPEAG	D2450V2	2450 MHz SAR Dipole	9/13/2016	Annual	9/13/2017	797
SPEAG	D2450V2	2450 MHz SAR Dipole	7/25/2016	Annual	7/25/2017	981
SPEAG	D5GHzV2	5 GHz SAR Dipole	8/2/2016	Annual	8/2/2017	1237
SPEAG	DAE4	Dasy Data Acquisition Electronics	2/9/2017	Annual	2/9/2018	665
SPEAG	DAE4	Dasy Data Acquisition Electronics	5/11/2016	Annual	5/11/2017	859
SPEAG	DAE4	Dasy Data Acquisition Electronics	2/9/2017	Annual	2/9/2018	1272
SPEAG	ES3DV3	SAR Probe	11/15/2016	Annual	11/15/2017	3334
SPEAG	DAE4	Dasy Data Acquisition Electronics	4/14/2016	Annual	4/14/2017	1407
SPEAG	DAE4	Dasy Data Acquisition Electronics	9/14/2016	Annual	9/14/2017	1408
SPEAG	DAE4	Dasy Data Acquisition Electronics	1/16/2017	Annual	1/16/2018	1466
SPEAG	DAK-3.5	Dielectric Assessment Kit	5/10/2016	Annual	5/10/2017	1070
SPEAG	ES3DV3	SAR Probe	2/10/2017	Annual	2/10/2018	3213
SPEAG	ES3DV3	SAR Probe	9/19/2016	Annual	9/19/2017	3287
SPEAG	ES3DV3	SAR Probe	2/10/2017	Annual	2/10/2018	3318
SPEAG	DAE4	Dasy Data Acquisition Electronics	11/11/2016	Annual	11/11/2017	1334
SPEAG	EX3DV4	SAR Probe	1/13/2017	Annual	1/13/2018	3589
SPEAG	EX3DV4	SAR Probe	7/21/2016	Annual	7/21/2017	7308
SPEAG	EX3DV4	SAR Probe	4/19/2016	Annual	4/19/2017	7406

Note: CBT (Calibrated Before Testing). Prior to testing, the measurement paths containing a cable, amplifier, attenuator, coupler or filter were connected to a calibrated source (i.e. a signal generator) to determine the losses of the measurement path. The power meter offset was then adjusted to compensate for the measurement system losses. This level offset is stored within the power meter before measurements are made. This calibration verification procedure applies to the system verification and output power measurements. The calibrated reading is then taken directly from the power meter after compensation of the losses for all final power measurements.

<b>FCC ID:</b> A3LSMJ530F	 <b>SAR EVALUATION REPORT</b> 		<b>Approved by:</b> Quality Manager
<b>Document S/N:</b> 1M1703200117-01.A3L	<b>Test Dates:</b> 03/20/17 - 04/05/17	<b>DUT Type:</b> Portable Handset	Page 45 of 49

# 15 MEASUREMENT UNCERTAINTIES

a	c	d	e= f(d,k)	f	g	h = c x f/e	i = c x g/e	k
Uncertainty Component	Tol. (± %)	Prob. Dist.	Div.	c <sub>i</sub> 1gm	c <sub>i</sub> 10 gms	1gm u <sub>i</sub> (± %)	10gms u <sub>i</sub> (± %)	v <sub>i</sub>
<b>Measurement System</b>								
Probe Calibration	6.55	N	1	1.0	1.0	6.6	6.6	∞
Axial Isotropy	0.25	N	1	0.7	0.7	0.2	0.2	∞
Hemishperical Isotropy	1.3	N	1	0.7	0.7	0.9	0.9	∞
Boundary Effect	2.0	R	1.73	1.0	1.0	1.2	1.2	∞
Linearity	0.3	N	1	1.0	1.0	0.3	0.3	∞
System Detection Limits	0.25	R	1.73	1.0	1.0	0.1	0.1	∞
Readout Electronics	0.3	N	1	1.0	1.0	0.3	0.3	∞
Response Time	0.8	R	1.73	1.0	1.0	0.5	0.5	∞
Integration Time	2.6	R	1.73	1.0	1.0	1.5	1.5	∞
RF Ambient Conditions - Noise	3.0	R	1.73	1.0	1.0	1.7	1.7	∞
RF Ambient Conditions - Reflections	3.0	R	1.73	1.0	1.0	1.7	1.7	∞
Probe Positioner Mechanical Tolerance	0.4	R	1.73	1.0	1.0	0.2	0.2	∞
Probe Positioning w/ respect to Phantom	6.7	R	1.73	1.0	1.0	3.9	3.9	∞
Extrapolation, Interpolation & Integration algorithms for Max. SAR Evaluation	4.0	R	1.73	1.0	1.0	2.3	2.3	∞
<b>Test Sample Related</b>								
Test Sample Positioning	2.7	N	1	1.0	1.0	2.7	2.7	35
Device Holder Uncertainty	1.67	N	1	1.0	1.0	1.7	1.7	5
Output Power Variation - SAR drift measurement	5.0	R	1.73	1.0	1.0	2.9	2.9	∞
SAR Scaling	0.0	R	1.73	1.0	1.0	0.0	0.0	∞
<b>Phantom &amp; Tissue Parameters</b>								
Phantom Uncertainty (Shape & Thickness tolerances)	7.6	R	1.73	1.0	1.0	4.4	4.4	∞
Liquid Conductivity - measurement uncertainty	4.2	N	1	0.78	0.71	3.3	3.0	10
Liquid Permittivity - measurement uncertainty	4.1	N	1	0.23	0.26	1.0	1.1	10
Liquid Conductivity - Temperature Uncertainty	3.4	R	1.73	0.78	0.71	1.5	1.4	∞
Liquid Permittivity - Temperature Uncertainty	0.6	R	1.73	0.23	0.26	0.1	0.1	∞
Liquid Conductivity - deviation from target values	5.0	R	1.73	0.64	0.43	1.8	1.2	∞
Liquid Permittivity - deviation from target values	5.0	R	1.73	0.60	0.49	1.7	1.4	∞
<b>Combined Standard Uncertainty (k=1)</b>	RSS					11.5	11.3	60
<b>Expanded Uncertainty</b> (95% CONFIDENCELEVEL)	k=2					23.0	22.6	



FCC ID: A3LSMJ530F		<b>SAR EVALUATION REPORT</b>		<b>Approved by:</b> Quality Manager
Document S/N: 1M1703200117-01.A3L	Test Dates: 03/20/17 - 04/05/17	DUT Type: Portable Handset	Page 46 of 49	

# 16 CONCLUSION

## 16.1 Measurement Conclusion



The SAR evaluation indicates that the EUT complies with the RF radiation exposure limits of the FCC and Innovation, Science, and Economic Development Canada, with respect to all parameters subject to this test. These measurements were taken to simulate the RF effects of RF exposure under worst-case conditions. Precise laboratory measures were taken to assure repeatability of the tests. The results and statements relate only to the item(s) tested.

Please note that the absorption and distribution of electromagnetic energy in the body are very complex phenomena that depend on the mass, shape, and size of the body, the orientation of the body with respect to the field vectors, and the electrical properties of both the body and the environment. Other variables that may play a substantial role in possible biological effects are those that characterize the environment (e.g. ambient temperature, air velocity, relative humidity, and body insulation) and those that characterize the individual (e.g. age, gender, activity level, debilitation, or disease). Because various factors may interact with one another to vary the specific biological outcome of an exposure to electromagnetic fields, any protection guide should consider maximal amplification of biological effects as a result of field-body interactions, environmental conditions, and physiological variables. [3]



<b>FCC ID:</b> A3LSMJ530F		<b>SAR EVALUATION REPORT</b>		<b>Approved by:</b> Quality Manager
<b>Document S/N:</b> 1M1703200117-01.A3L	<b>Test Dates:</b> 03/20/17 - 04/05/17	<b>DUT Type:</b> Portable Handset	Page 47 of 49	

# 17 REFERENCES

- [1] Federal Communications Commission, ET Docket 93-62, Guidelines for Evaluating the Environmental Effects of Radiofrequency Radiation, Aug. 1996.
- [2] ANSI/IEEE C95.1-2005, American National Standard safety levels with respect to human exposure to radio frequency electromagnetic fields, 3kHz to 300GHz, New York: IEEE, 2006.
- [3] ANSI/IEEE C95.1-1992, American National Standard safety levels with respect to human exposure to radio frequency electromagnetic fields, 3kHz to 300GHz, New York: IEEE, Sept. 1992.
- [4] ANSI/IEEE C95.3-2002, IEEE Recommended Practice for the Measurement of Potentially Hazardous Electromagnetic Fields - RF and Microwave, New York: IEEE, December 2002.
- [5] IEEE Standards Coordinating Committee 39 –Standards Coordinating Committee 34 – IEEE Std. 1528-2013, IEEE Recommended Practice for Determining the Peak Spatial-Average Specific Absorption Rate (SAR) in the Human Head from Wireless Communications Devices: Measurement Techniques.
- [6] NCRP, National Council on Radiation Protection and Measurements, Biological Effects and Exposure Criteria for RadioFrequency Electromagnetic Fields, NCRP Report No. 86, 1986. Reprinted Feb. 1995.
- [7] T. Schmid, O. Egger, N. Kuster, Automated E-field scanning system for dosimetric assessments, IEEE Transaction on Microwave Theory and Techniques, vol. 44, Jan. 1996, pp. 105-113.
- [8] K. Pokovic, T. Schmid, N. Kuster, Robust setup for precise calibration of E-field probes in tissue simulating liquids at mobile communications frequencies, ICECOM97, Oct. 1997, pp. 1 -124.
- [9] K. Pokovic, T. Schmid, and N. Kuster, E-field Probe with improved isotropy in brain simulating liquids, Proceedings of the ELMAR, Zadar, Croatia, June 23-25, 1996, pp. 172-175.
- [10] Schmid & Partner Engineering AG, Application Note: Data Storage and Evaluation, June 1998, p2.
- [11] V. Hombach, K. Meier, M. Burkhardt, E. Kuhn, N. Kuster, The Dependence of EM Energy Absorption upon Human Modeling at 900 MHz, IEEE Transaction on Microwave Theory and Techniques, vol. 44 no. 10, Oct. 1996, pp. 1865-1873.
- [12] N. Kuster and Q. Balzano, Energy absorption mechanism by biological bodies in the near field of dipole antennas above 300MHz, IEEE Transaction on Vehicular Technology, vol. 41, no. 1, Feb. 1992, pp. 17-23.
- [13] G. Hartsgrove, A. Kraszewski, A. Surowiec, Simulated Biological Materials for Electromagnetic Radiation Absorption Studies, University of Ottawa, Bioelectromagnetics, Canada: 1987, pp. 29-36.
- [14] Q. Balzano, O. Garay, T. Manning Jr., Electromagnetic Energy Exposure of Simulated Users of Portable Cellular Telephones, IEEE Transactions on Vehicular Technology, vol. 44, no.3, Aug. 1995.
- [15] W. Gander, Computermathematick, Birkhaeuser, Basel, 1992.
- [16] W.H. Press, S.A. Teukolsky, W.T. Vetterling, and B.P. Flannery, Numerical Recipes in C, The Art of Scientific Computing, Second edition, Cambridge University Press, 1992.
- [17] N. Kuster, R. Kastle, T. Schmid, Dosimetric evaluation of mobile communications equipment with known precision, IEEE Transaction on Communications, vol. E80-B, no. 5, May 1997, pp. 645-652.

<b>FCC ID:</b> A3LSMJ530F	 <b>SAR EVALUATION REPORT</b> 		<b>Approved by:</b> Quality Manager
<b>Document S/N:</b> 1M1703200117-01.A3L	<b>Test Dates:</b> 03/20/17 - 04/05/17	<b>DUT Type:</b> Portable Handset	Page 48 of 49

- [18] CENELEC CLC/SC111B, European Prestandard (prENV 50166-2), Human Exposure to Electromagnetic Fields High-frequency: 10kHz-300GHz, Jan. 1995.
- [19] Prof. Dr. Niels Kuster, ETH, Eidgenössische Technische Hochschule Zürich, Dosimetric Evaluation of the Cellular Phone.
- [20] IEC 62209-1, Human exposure to radio frequency fields from hand-held and body-mounted wireless communication devices - Human models, instrumentation, and procedures - Part 1: Procedure to determine the specific absorption rate (SAR) for hand-held devices used in close proximity to the ear (frequency range of 300 MHz to 3 GHz), Feb. 2005.
- [21] Innovation, Science, Economic Development Canada RSS-102 Radio Frequency Exposure Compliance of Radiocommunication Apparatus (All Frequency Bands) Issue 5, March 2015.
- [22] Health Canada Safety Code 6 Limits of Human Exposure to Radio Frequency Electromagnetic Fields in the Frequency Range from 3 kHz – 300 GHz, 2015
- [23] FCC SAR Test Procedures for 2G-3G Devices, Mobile Hotspot and UMPC Devices KDB Publications 941225, D01-D07
- [24] SAR Measurement Guidance for IEEE 802.11 Transmitters, KDB Publication 248227 D01
- [25] FCC SAR Considerations for Handsets with Multiple Transmitters and Antennas, KDB Publications 648474 D03-D04
- [26] FCC SAR Evaluation Considerations for Laptop, Notebook, Netbook and Tablet Computers, FCC KDB Publication 616217 D04
- [27] FCC SAR Measurement and Reporting Requirements for 100MHz – 6 GHz, KDB Publications 865664 D01-D02
- [28] FCC General RF Exposure Guidance and SAR Procedures for Dongles, KDB Publication 447498, D01-D02
- [29] Anexo à Resolução No. 533, de 10 de Setembro de 2009.
- [30] IEC 62209-2, Human exposure to radio frequency fields from hand-held and body-mounted wireless communication devices - Human models, instrumentation, and procedures - Part 2: Procedure to determine the specific absorption rate (SAR) for wireless communication devices used in close proximity to the human body (frequency range of 30 MHz to 6 GHz), Mar. 2010.

<b>FCC ID:</b> A3LSMJ530F		<b>SAR EVALUATION REPORT</b>		<b>Approved by:</b> Quality Manager
<b>Document S/N:</b> 1M1703200117-01.A3L	<b>Test Dates:</b> 03/20/17 - 04/05/17	<b>DUT Type:</b> Portable Handset	Page 49 of 49	

## APPENDIX A: SAR TEST DATA

# PCTEST ENGINEERING LABORATORY, INC.

**DUT: A3LSMJ530F; Type: Portable Handset; Serial: 11456**

Communication System: UID 0, GSM; Frequency: 836.6 MHz; Duty Cycle: 1:8.3  
Medium: 835 Head Medium parameters used (interpolated):  
 $f = 836.6 \text{ MHz}$ ;  $\sigma = 0.897 \text{ S/m}$ ;  $\epsilon_r = 40.447$ ;  $\rho = 1000 \text{ kg/m}^3$   
Phantom section: Right Section

Test Date: 03-20-2017; Ambient Temp: 22.3°C; Tissue Temp: 20.5°C

Probe: EX3DV4 - SN7406; ConvF(9.83, 9.83, 9.83); Calibrated: 4/19/2016;  
Sensor-Surface: 1.4mm (Mechanical Surface Detection)  
Electronics: DAE4 Sn1407; Calibrated: 4/14/2016  
Phantom: SAM V5.0 Right; Type: QD000P40CD; Serial: 1647  
Measurement SW: DASY52, Version 52.8 (8); SEMCAD X Version 14.6.10 (7331)

**Mode: GSM 850, Right Head, Cheek, Mid.ch**

**Area Scan (9x15x1):** Measurement grid: dx=15mm, dy=15mm

**Zoom Scan (5x5x7)/Cube 0:** Measurement grid: dx=8mm, dy=8mm, dz=5mm

Reference Value = 6.639 V/m; Power Drift = 0.20 dB

Peak SAR (extrapolated) = 0.0460 W/kg

**SAR(1 g) = 0.037 W/kg**

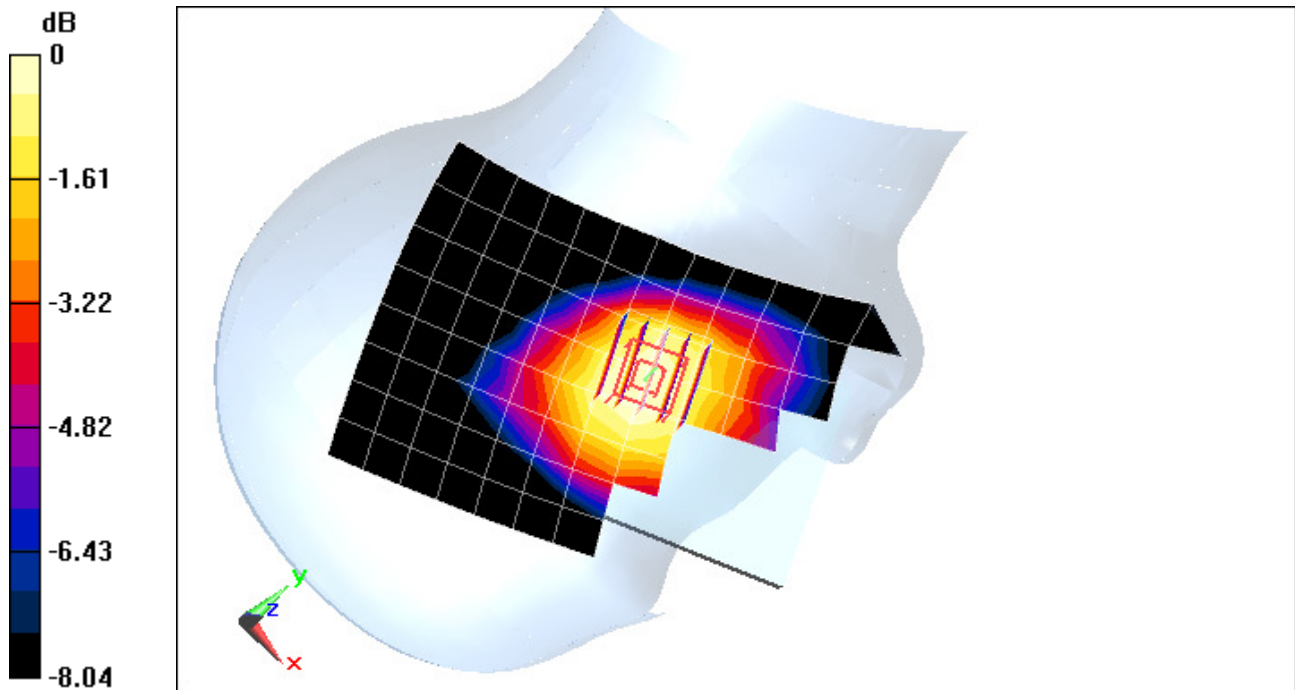

0 dB = 0.0428 W/kg = -13.69 dBW/kg

# PCTEST ENGINEERING LABORATORY, INC.

**DUT: A3LSMJ530F; Type: Portable Handset; Serial: 11456**

Communication System: UID 0, GSM; Frequency: 1880 MHz; Duty Cycle: 1:8.3

Medium: 1900 Head Medium parameters used:

$f = 1880 \text{ MHz}$ ;  $\sigma = 1.428 \text{ S/m}$ ;  $\epsilon_r = 39.495$ ;  $\rho = 1000 \text{ kg/m}^3$

Phantom section: Left Section

Test Date: 03-20-2017; Ambient Temp: 22.0°C; Tissue Temp: 21.3°C

Probe: ES3DV3 - SN3318; ConvF(5.31, 5.31, 5.31); Calibrated: 2/10/2017;

Sensor-Surface: 3mm (Mechanical Surface Detection)

Electronics: DAE4 Sn665; Calibrated: 2/9/2017

Phantom: SAM with CRP (Left); Type: SAM; Serial: 1715

Measurement SW: DASY52, Version 52.8 (8); SEMCAD X Version 14.6.10 (7331)

**Mode: GSM 1900, Left Head, Cheek, Mid.ch**

**Area Scan (9x15x1):** Measurement grid: dx=15mm, dy=15mm

**Zoom Scan (5x5x7)/Cube 0:** Measurement grid: dx=8mm, dy=8mm, dz=5mm

Reference Value = 6.541 V/m; Power Drift = 0.18 dB

Peak SAR (extrapolated) = 0.0860 W/kg

**SAR(1 g) = 0.058 W/kg**

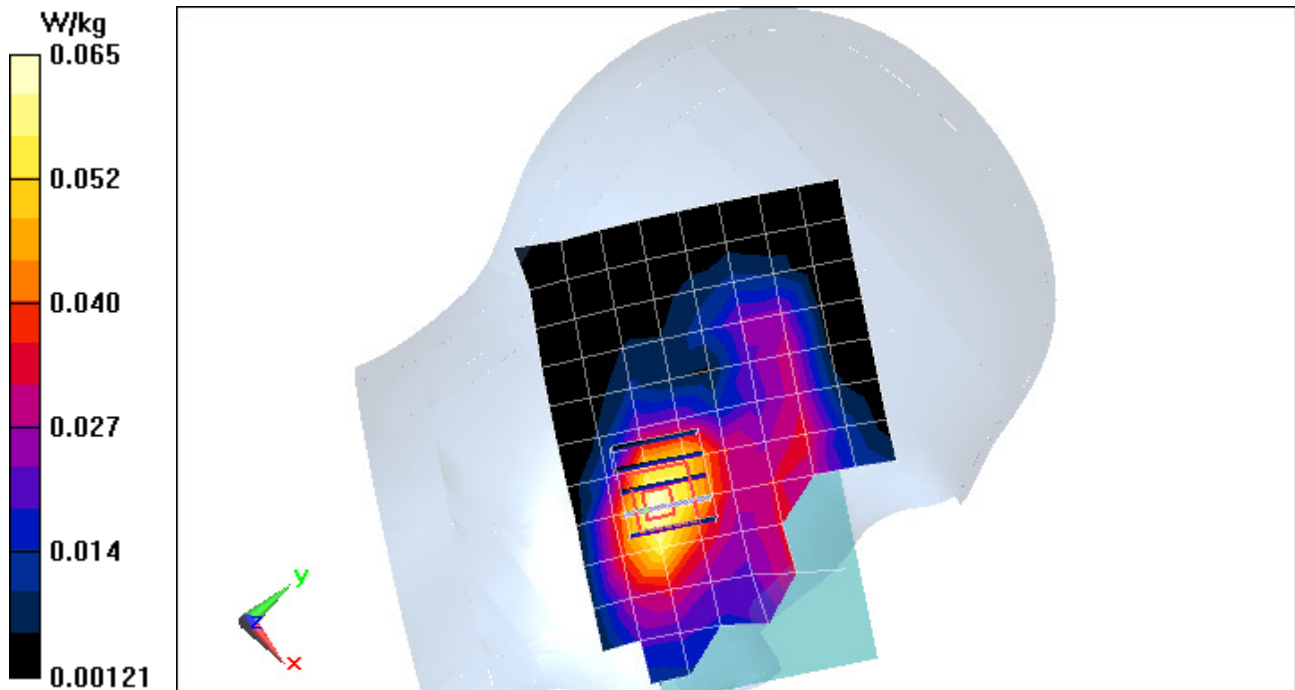

# PCTEST ENGINEERING LABORATORY, INC.

**DUT: A3LSMJ530F; Type: Portable Handset; Serial: 29760**

Communication System: UID 0, UMTS; Frequency: 836.6 MHz; Duty Cycle: 1:1  
Medium: 835 Head Medium parameters used (interpolated):  
 $f = 836.6 \text{ MHz}$ ;  $\sigma = 0.896 \text{ S/m}$ ;  $\epsilon_r = 42.954$ ;  $\rho = 1000 \text{ kg/m}^3$   
Phantom section: Right Section

Test Date: 03-22-2017; Ambient Temp: 21.3°C; Tissue Temp: 21.8°C

Probe: ES3DV3 - SN3334; ConvF(6.49, 6.49, 6.49); Calibrated: 11/15/2016;  
Sensor-Surface: 3mm (Mechanical Surface Detection)  
Electronics: DAE4 Sn1334; Calibrated: 11/11/2016  
Phantom: SAM with CRP v4.0; Type: QD000P40CD; Serial: TP:1800  
Measurement SW: DASY52, Version 52.8 (8); SEMCAD X Version 14.6.10 (7331)

**Mode: UMTS 850, Right Head, Cheek, Mid.ch**

**Area Scan (9x15x1):** Measurement grid: dx=15mm, dy=15mm

**Zoom Scan (6x5x7)/Cube 0:** Measurement grid: dx=8mm, dy=8mm, dz=5mm

Reference Value = 11.25 V/m; Power Drift = -0.01 dB

Peak SAR (extrapolated) = 0.134 W/kg

**SAR(1 g) = 0.107 W/kg**

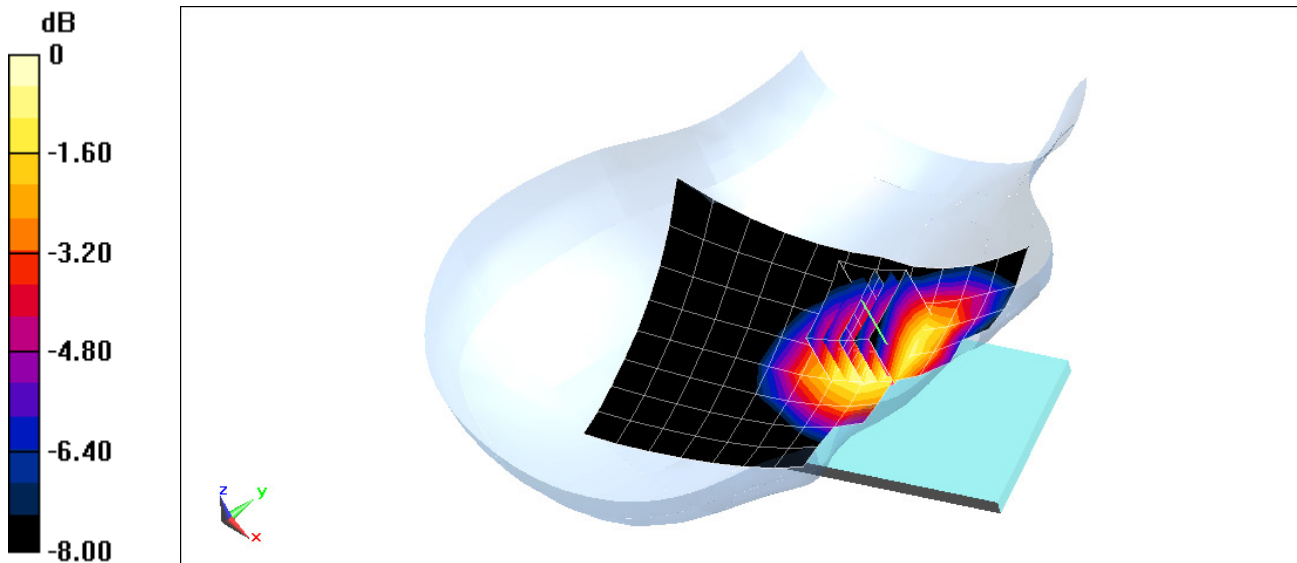

0 dB = 0.115 W/kg = -9.39 dBW/kg

# PCTEST ENGINEERING LABORATORY, INC.

**DUT: A3LSMJ530F; Type: Portable Handset; Serial: 12355**

Communication System: UID 0, UMTS; Frequency: 1732.4 MHz; Duty Cycle: 1:1  
Medium: 1750 Head Medium parameters used (interpolated):  
 $f = 1732.4 \text{ MHz}$ ;  $\sigma = 1.32 \text{ S/m}$ ;  $\epsilon_r = 39.009$ ;  $\rho = 1000 \text{ kg/m}^3$   
Phantom section: Left Section

Test Date: 03-22-2017; Ambient Temp: 24.1°C; Tissue Temp: 22.0°C

Probe: ES3DV3 - SN3318; ConvF(5.49, 5.49, 5.49); Calibrated: 2/10/2017;  
Sensor-Surface: 3mm (Mechanical Surface Detection)  
Electronics: DAE4 Sn665; Calibrated: 2/9/2017

Phantom: SAM with CRP v5.0 (Right); Type: QD000P40CD; Serial: TP:1759  
Measurement SW: DASY52, Version 52.8 (8); SEMCAD X Version 14.6.10 (7331)

**Mode: UMTS 1750, Left Head, Cheek, Mid.ch**

**Area Scan (9x14x1):** Measurement grid: dx=15mm, dy=15mm

**Zoom Scan (5x5x7)/Cube 0:** Measurement grid: dx=8mm, dy=8mm, dz=5mm

Reference Value = 8.147 V/m; Power Drift = 0.05 dB

Peak SAR (extrapolated) = 0.119 W/kg

**SAR(1 g) = 0.079 W/kg**

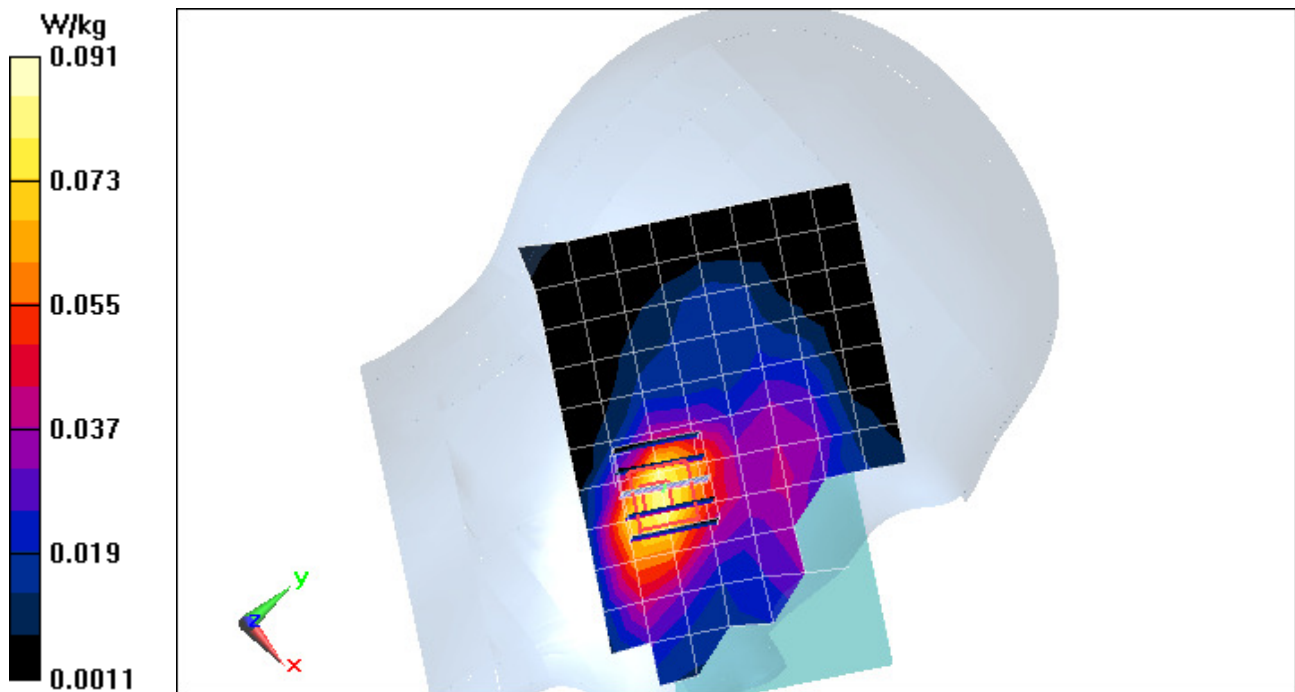

# PCTEST ENGINEERING LABORATORY, INC.

**DUT: A3LSMJ530F; Type: Portable Handset; Serial: 11456**

Communication System: UID 0, UMTS; Frequency: 1880.0 MHz; Duty Cycle: 1:1  
Medium: 1900 Head Medium parameters used (interpolated):  
 $f = 1880$  MHz;  $\sigma = 1.428$  S/m;  $\epsilon_r = 39.495$ ;  $\rho = 1000$  kg/m<sup>3</sup>  
Phantom section: Left Section

Test Date: 03-20-2017; Ambient Temp: 22.0°C; Tissue Temp: 21.3°C

Probe: ES3DV3 - SN3318; ConvF(5.31, 5.31, 5.31); Calibrated: 2/10/2017;  
Sensor-Surface: 3mm (Mechanical Surface Detection)  
Electronics: DAE4 Sn665; Calibrated: 2/9/2017  
Phantom: SAM with CRP (Left); Type: SAM; Serial: 1715  
Measurement SW: DASY52, Version 52.8 (8); SEMCAD X Version 14.6.10 (7331)

**Mode: UMTS 1900, Left Head, Cheek, Mid.ch**

**Area Scan (9x15x1):** Measurement grid: dx=15mm, dy=15mm

**Zoom Scan (5x5x7)/Cube 0:** Measurement grid: dx=8mm, dy=8mm, dz=5mm

Reference Value = 9.452 V/m; Power Drift = 0.10 dB

Peak SAR (extrapolated) = 0.179 W/kg

**SAR(1 g) = 0.117 W/kg**

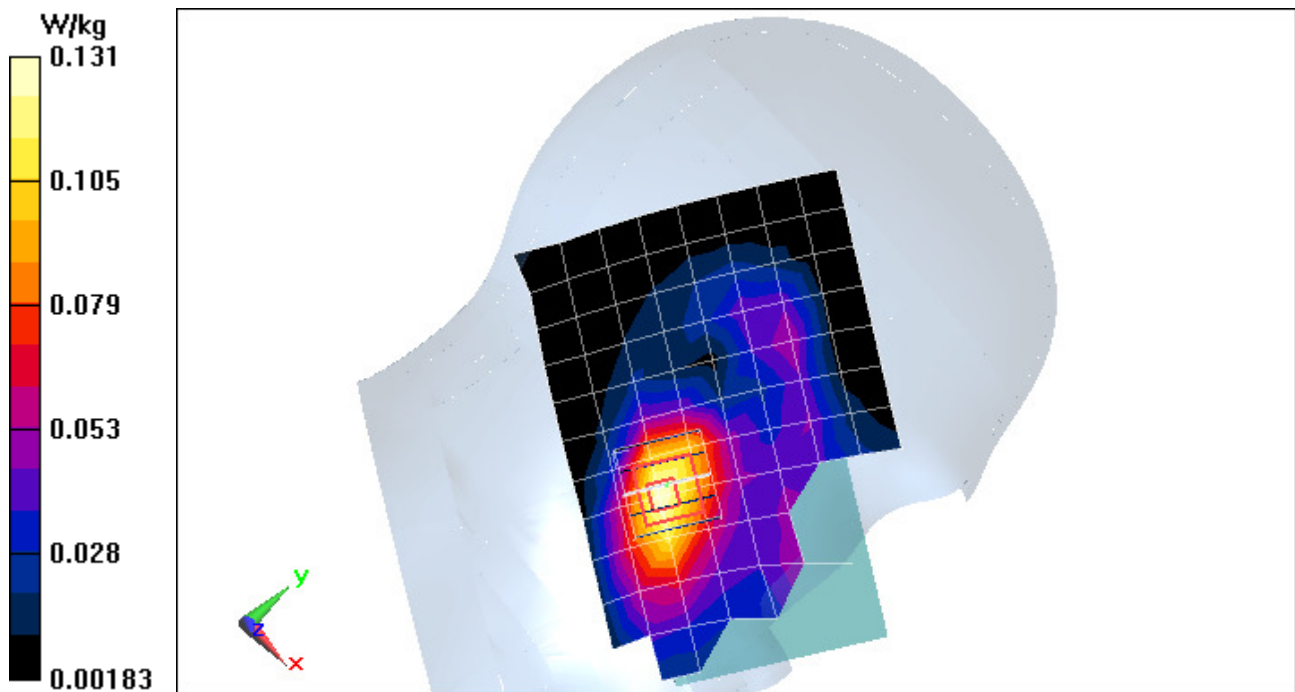

# PCTEST ENGINEERING LABORATORY, INC.

**DUT: A3LSMJ530F; Type: Portable Handset; Serial: 11456**

Communication System: UID 0, LTE Band 5 (Cell.); Frequency: 836.5 MHz; Duty Cycle: 1:1  
Medium: 835 Head Medium parameters used (interpolated):  
 $f = 836.5 \text{ MHz}$ ;  $\sigma = 0.897 \text{ S/m}$ ;  $\epsilon_r = 40.448$ ;  $\rho = 1000 \text{ kg/m}^3$   
Phantom section: Left Section

Test Date: 03-20-2017; Ambient Temp: 22.3°C; Tissue Temp: 20.5°C

Probe: EX3DV4 - SN7406; ConvF(9.83, 9.83, 9.83); Calibrated: 4/19/2016;  
Sensor-Surface: 1.4mm (Mechanical Surface Detection)  
Electronics: DAE4 Sn1407; Calibrated: 4/14/2016  
Phantom: SAM V5.0 Right; Type: QD000P40CD; Serial: 1647  
Measurement SW: DASY52, Version 52.8 (8); SEMCAD X Version 14.6.10 (7331)

**Mode: LTE Band 5 (Cell.), Left Head, Cheek, Mid.ch,  
10 MHz Bandwidth, QPSK, 1 RB, 25 RB Offset**

**Area Scan (9x15x1):** Measurement grid: dx=15mm, dy=15mm

**Zoom Scan (6x5x7)/Cube 0:** Measurement grid: dx=8mm, dy=8mm, dz=5mm

Reference Value = 7.707 V/m; Power Drift = -0.02 dB

Peak SAR (extrapolated) = 0.0590 W/kg

**SAR(1 g) = 0.047 W/kg**

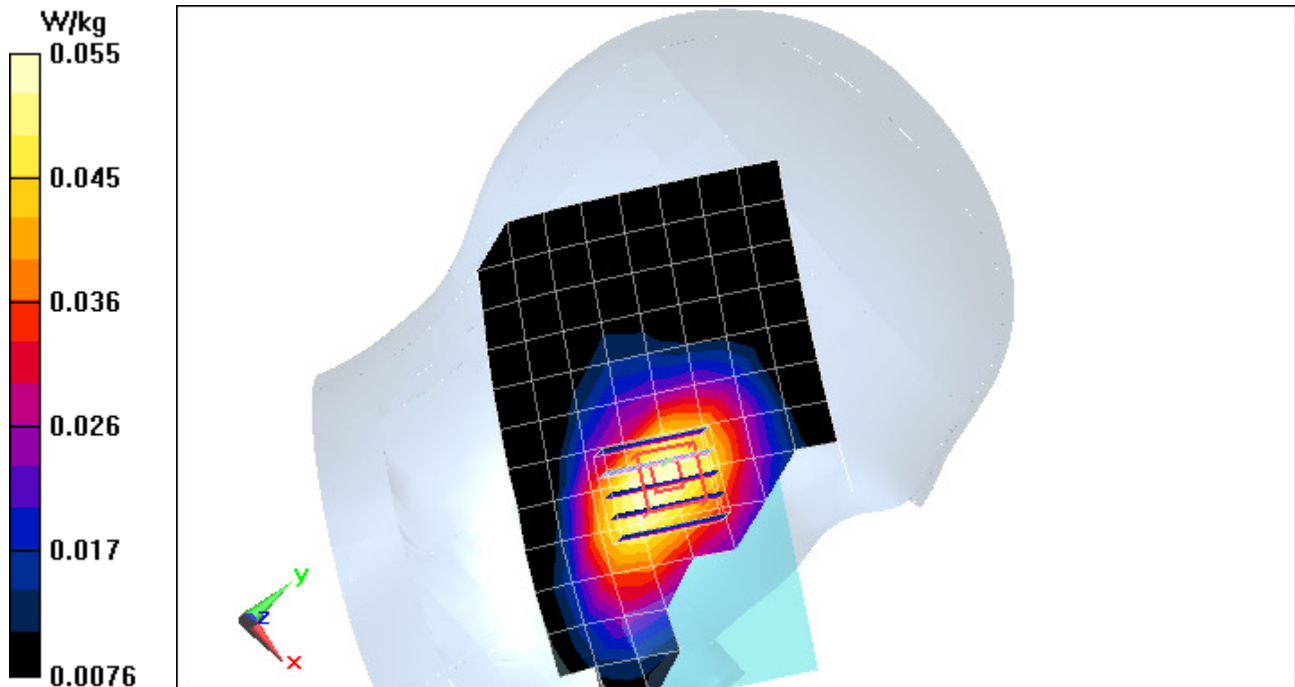

# PCTEST ENGINEERING LABORATORY, INC.

**DUT: A3LSMJ530F; Type: Portable Handset; Serial: 74852**

Communication System: UID 0, IEEE 802.11b; Frequency: 2412 MHz; Duty Cycle: 1:1  
Medium: 2450 Head Medium parameters used (interpolated):  
 $f = 2412 \text{ MHz}$ ;  $\sigma = 1.809 \text{ S/m}$ ;  $\epsilon_r = 38.107$ ;  $\rho = 1000 \text{ kg/m}^3$   
Phantom section: Right Section

Test Date: 03-23-2017; Ambient Temp: 21.3°C; Tissue Temp: 22.9°C

Probe: ES3DV3 - SN3287; ConvF(4.54, 4.54, 4.54); Calibrated: 9/19/2016;  
Sensor-Surface: 3mm (Mechanical Surface Detection)  
Electronics: DAE4 Sn1408; Calibrated: 9/14/2016  
Phantom: SAM Left; Type: QD000P40CA; Serial: TP:82355  
Measurement SW: DASY52, Version 52.8 (8); SEMCAD X Version 14.6.10 (7331)

**Mode: IEEE 802.11b, 22 MHz Bandwidth, Right Head, Tilt, Ch 1, 1 Mbps**

**Area Scan (11x18x1):** Measurement grid: dx=12mm, dy=12mm

**Zoom Scan (8x7x7)/Cube 0:** Measurement grid: dx=5mm, dy=5mm, dz=5mm

Reference Value = 22.14 V/m; Power Drift = 0.00 dB

Peak SAR (extrapolated) = 1.67 W/kg

**SAR(1 g) = 0.717 W/kg**

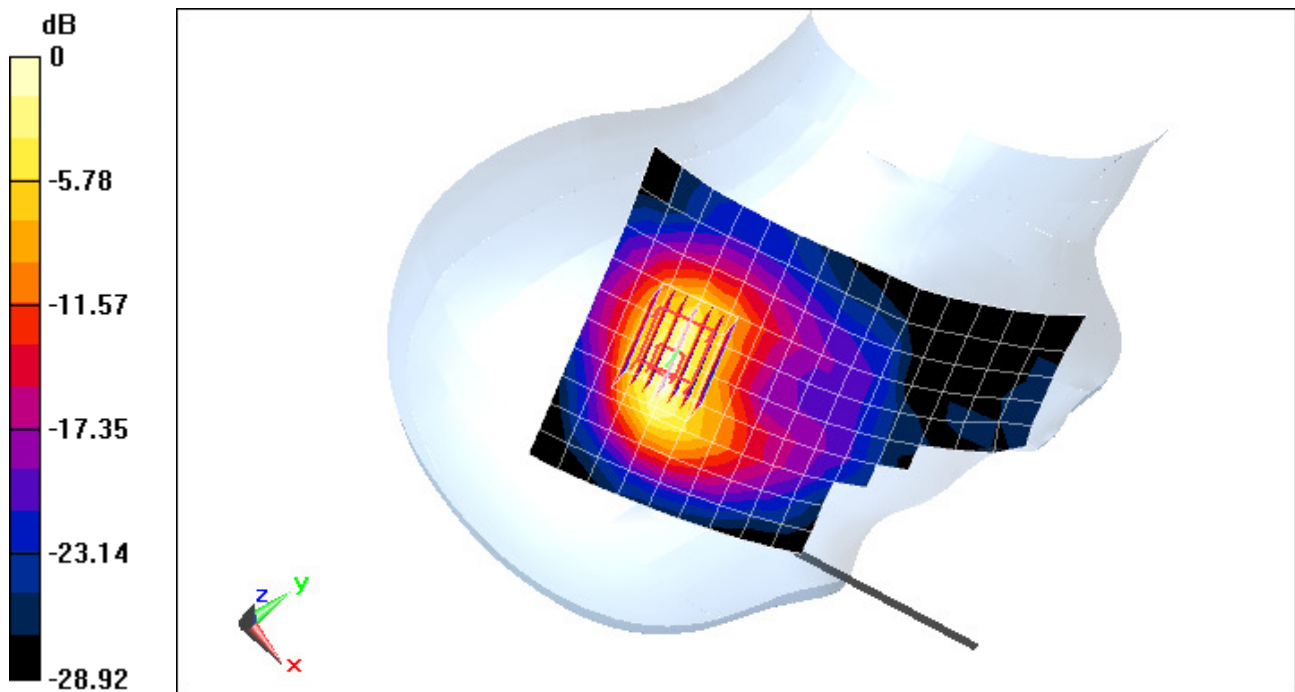

0 dB = 1.00 W/kg = 0.00 dBW/kg

# PCTEST ENGINEERING LABORATORY, INC.

**DUT: A3LSMJ530F; Type: Portable Handset; Serial: 19228**

Communication System: UID 0, 802.11a 5.2-5.8 GHz Band; Frequency: 5260 MHz; Duty Cycle: 1:1

Medium: 5GHz Head Medium parameters used:

$f = 5260 \text{ MHz}$ ;  $\sigma = 4.657 \text{ S/m}$ ;  $\epsilon_r = 35.474$ ;  $\rho = 1000 \text{ kg/m}^3$

Phantom section: Right Section

Test Date: 03-27-2017; Ambient Temp: 22.7°C; Tissue Temp: 21.0°C

Probe: EX3DV4 - SN7308; ConvF(5.21, 5.21, 5.21); Calibrated: 7/21/2016;

Sensor-Surface: 1.4mm (Mechanical Surface Detection)

Electronics: DAE4 Sn859; Calibrated: 5/11/2016

Phantom: SAM Left; Type: QD000P40CC; Serial: TP: 1375

Measurement SW: DASY52, Version 52.8 (8); SEMCAD X Version 14.6.10 (7331)

**Mode: IEEE 802.11a, U-NII-2A, 20 MHz Bandwidth, Right Head, Cheek, Ch 52, 6 Mbps**

**Area Scan (12x20x1):** Measurement grid: dx=10mm, dy=10mm

**Zoom Scan (8x8x7)/Cube 0:** Measurement grid: dx=4mm, dy=4mm, dz=1.4mm; Graded Ratio: 1.4

Reference Value = 8.577 V/m; Power Drift = 0.20 dB

Peak SAR (extrapolated) = 4.57 W/kg

**SAR(1 g) = 1.01 W/kg**

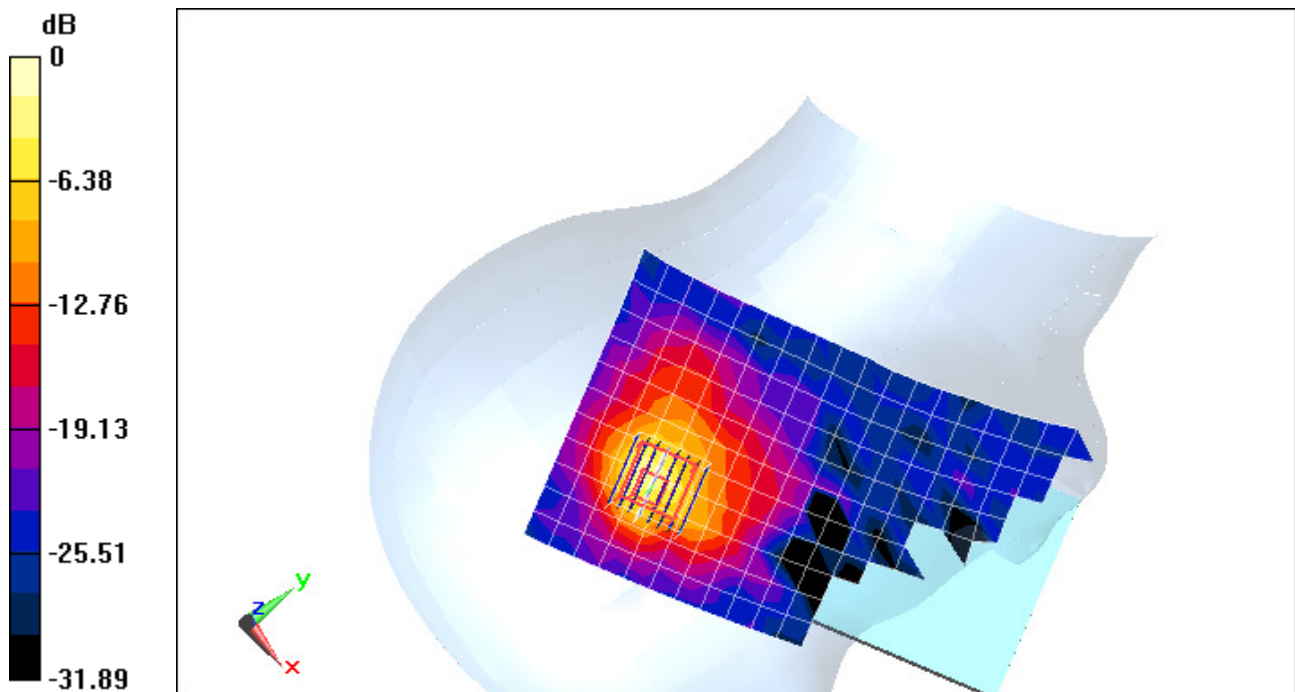

0 dB = 2.64 W/kg = 4.22 dBW/kg

# PCTEST ENGINEERING LABORATORY, INC.

**DUT: A3LSMJ530F; Type: Portable Handset; Serial: 29760**

Communication System: UID 0, GSM; Frequency: 836.6 MHz; Duty Cycle: 1:8.3  
Medium: 835 Body Medium parameters used (interpolated):  
 $f = 836.6 \text{ MHz}$ ;  $\sigma = 0.993 \text{ S/m}$ ;  $\epsilon_r = 54.06$ ;  $\rho = 1000 \text{ kg/m}^3$   
Phantom section: Flat Section; Space: 1.5 cm

Test Date: 03-27-2017; Ambient Temp: 21.4°C; Tissue Temp: 21.5°C

Probe: ES3DV3 - SN3318; ConvF(6.37, 6.37, 6.37); Calibrated: 2/10/2017;  
Sensor-Surface: 3mm (Mechanical Surface Detection)  
Electronics: DAE4 Sn665; Calibrated: 2/9/2017  
Phantom: SAM with CRP (Left); Type: SAM; Serial: 1715  
Measurement SW: DASY52, Version 52.8 (8); SEMCAD X Version 14.6.10 (7331)

**Mode: GSM 850, Body SAR, Back Side, Mid.ch**

**Area Scan (9x15x1):** Measurement grid: dx=15mm, dy=15mm

**Zoom Scan (5x5x7)/Cube 0:** Measurement grid: dx=8mm, dy=8mm, dz=5mm

Reference Value = 13.62 V/m; Power Drift = 0.03 dB

Peak SAR (extrapolated) = 0.230 W/kg

**SAR(1 g) = 0.172 W/kg**

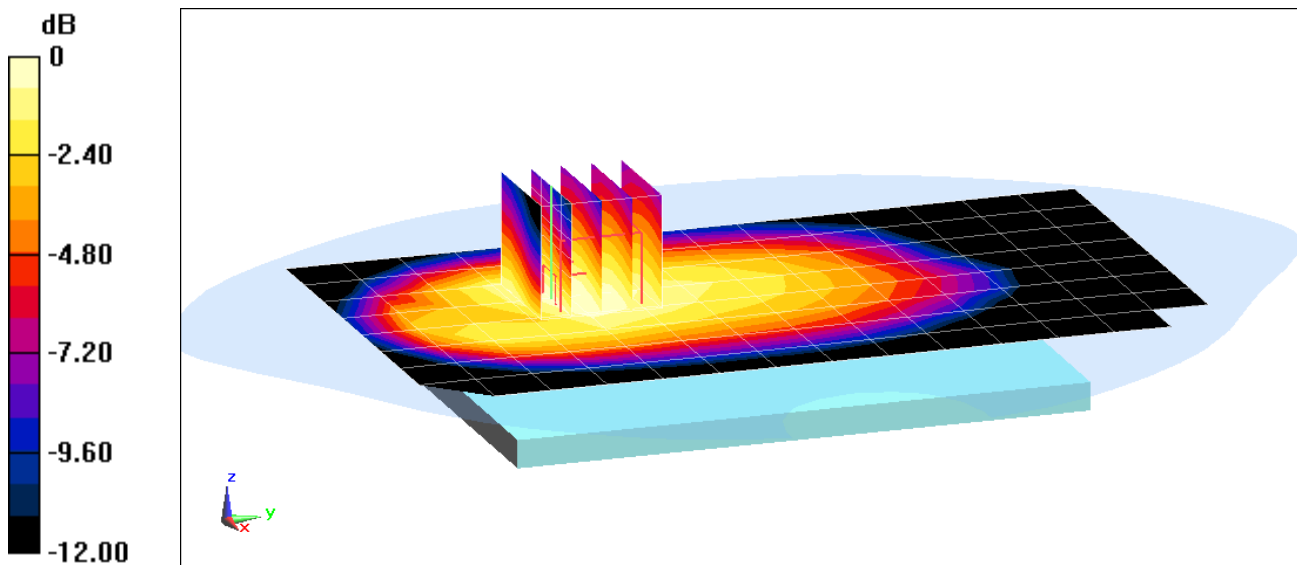

# PCTEST ENGINEERING LABORATORY, INC.

**DUT: A3LSMJ530F; Type: Portable Handset; Serial: 29760**

Communication System: UID 0, GSM GPRS; 3 Tx slots; Frequency: 836.6 MHz; Duty Cycle: 1:2.76  
Medium: 835 Body Medium parameters used (interpolated):  
 $f = 836.6 \text{ MHz}$ ;  $\sigma = 0.993 \text{ S/m}$ ;  $\epsilon_r = 54.06$ ;  $\rho = 1000 \text{ kg/m}^3$   
Phantom section: Flat Section; Space: 1.0 cm

Test Date: 03-27-2017; Ambient Temp: 21.4°C; Tissue Temp: 21.5°C

Probe: ES3DV3 - SN3318; ConvF(6.37, 6.37, 6.37); Calibrated: 2/10/2017;  
Sensor-Surface: 3mm (Mechanical Surface Detection)  
Electronics: DAE4 Sn665; Calibrated: 2/9/2017  
Phantom: SAM with CRP (Left); Type: SAM; Serial: 1715  
Measurement SW: DASY52, Version 52.8 (8); SEMCAD X Version 14.6.10 (7331)

**Mode: GPRS 850, Body SAR, Back Side, Mid.ch, 3 Tx Slots**

**Area Scan (9x15x1):** Measurement grid: dx=15mm, dy=15mm  
**Zoom Scan (5x5x7)/Cube 0:** Measurement grid: dx=8mm, dy=8mm, dz=5mm  
Reference Value = 13.68 V/m; Power Drift = -0.03 dB  
Peak SAR (extrapolated) = 0.295 W/kg  
**SAR(1 g) = 0.166 W/kg**

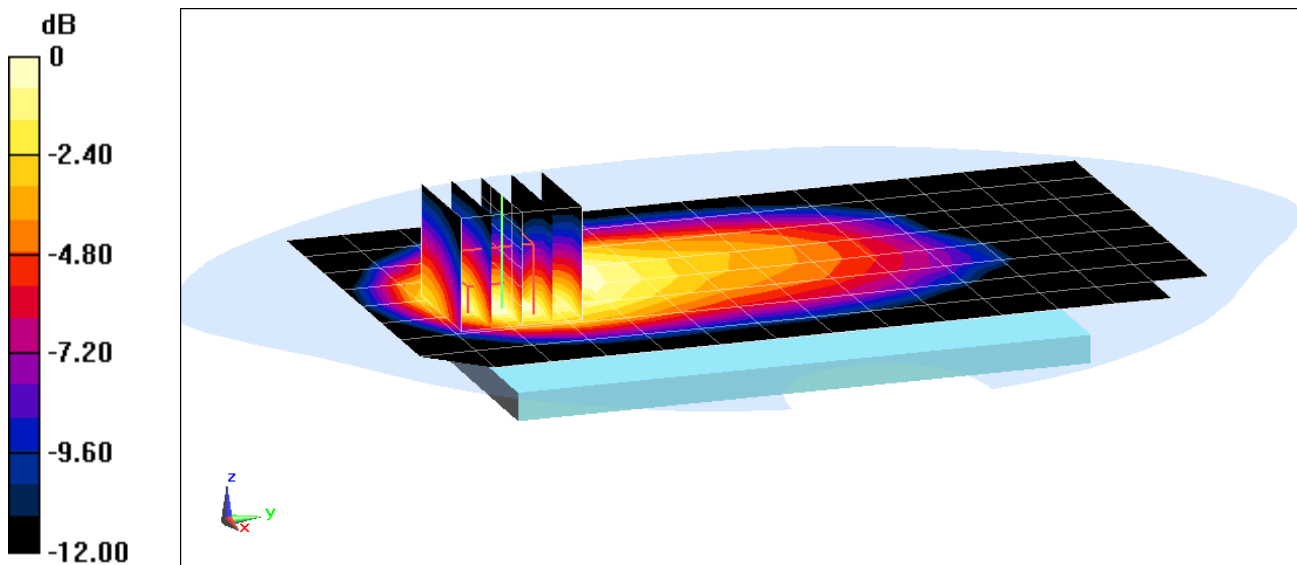

0 dB = 0.203 W/kg = -6.93 dBW/kg

# PCTEST ENGINEERING LABORATORY, INC.

**DUT: A3LSMJ530F; Type: Portable Handset; Serial: 29828**

Communication System: UID 0, GSM; Frequency: 1880 MHz; Duty Cycle: 1:8.3

Medium: 1900 Body Medium parameters used:

$f = 1880 \text{ MHz}$ ;  $\sigma = 1.552 \text{ S/m}$ ;  $\epsilon_r = 52.413$ ;  $\rho = 1000 \text{ kg/m}^3$

Phantom section: Flat Section; Space: 1.5 cm

Test Date: 03-27-2017; Ambient Temp: 21.8°C; Tissue Temp: 22.3°C

Probe: ES3DV3 - SN3287; ConvF(4.94, 4.94, 4.94); Calibrated: 9/19/2016;

Sensor-Surface: 3mm (Mechanical Surface Detection)

Electronics: DAE4 Sn1408; Calibrated: 9/14/2016

Phantom: SAM Front; Type: SAM; Serial: 1686

Measurement SW: DASY52, Version 52.8 (8); SEMCAD X Version 14.6.10 (7331)

**Mode: GSM 1900, Body SAR, Back Side, Mid.ch**

**Area Scan (9x14x1):** Measurement grid: dx=15mm, dy=15mm

**Zoom Scan (5x5x7)/Cube 0:** Measurement grid: dx=8mm, dy=8mm, dz=5mm

Reference Value = 18.01 V/m; Power Drift = 0.06 dB

Peak SAR (extrapolated) = 0.696 W/kg

**SAR(1 g) = 0.441 W/kg**

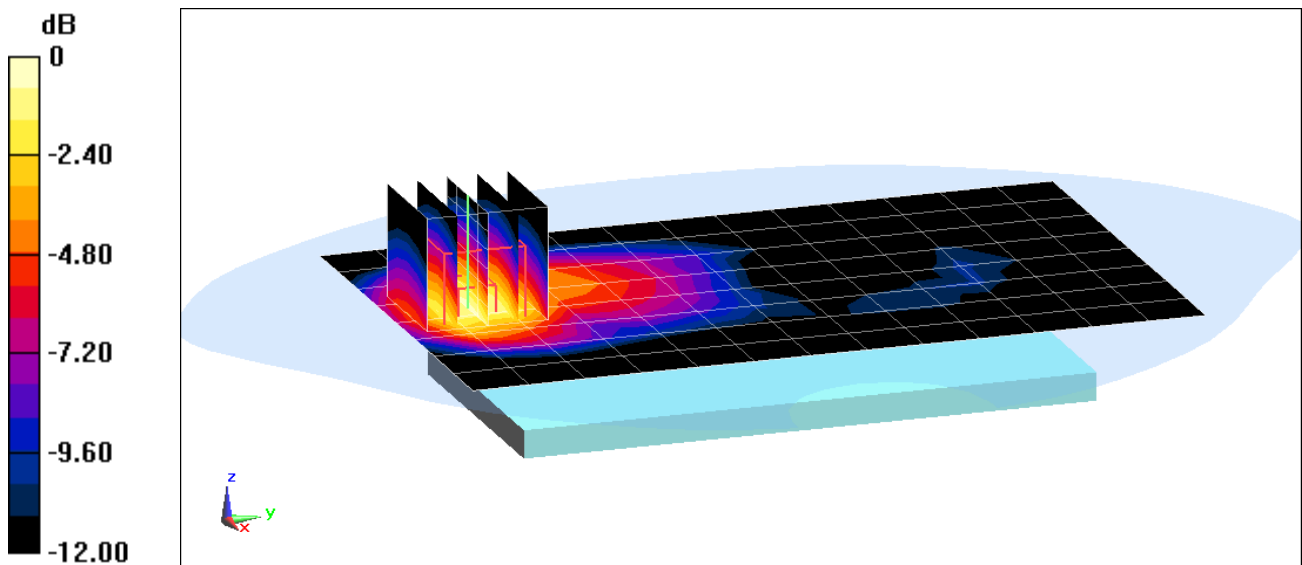

# PCTEST ENGINEERING LABORATORY, INC.

**DUT: A3LSMJ530F; Type: Portable Handset; Serial: 29828**

Communication System: UID 0, GSM GPRS; 4 Tx slots; Frequency: 1850.2 MHz; Duty Cycle: 1:2.076  
Medium: 1900 Body Medium parameters used (interpolated):  
 $f = 1850.2 \text{ MHz}$ ;  $\sigma = 1.517 \text{ S/m}$ ;  $\epsilon_r = 52.531$ ;  $\rho = 1000 \text{ kg/m}^3$   
Phantom section: Flat Section; Space: 1.0 cm

Test Date: 03-27-2017; Ambient Temp: 21.8°C; Tissue Temp: 22.3°C

Probe: ES3DV3 - SN3287; ConvF(4.94, 4.94, 4.94); Calibrated: 9/19/2016;  
Sensor-Surface: 3mm (Mechanical Surface Detection)  
Electronics: DAE4 Sn1408; Calibrated: 9/14/2016  
Phantom: SAM Front; Type: SAM; Serial: 1686  
Measurement SW: DASY52, Version 52.8 (8); SEMCAD X Version 14.6.10 (7331)

**Mode: GPRS 1900, Body SAR, Bottom Edge, Low.ch, 4 Tx Slots**

**Area Scan (10x9x1):** Measurement grid: dx=5mm, dy=15mm  
**Zoom Scan (5x5x7)/Cube 0:** Measurement grid: dx=8mm, dy=8mm, dz=5mm  
Reference Value = 19.10 V/m; Power Drift = 0.15 dB  
Peak SAR (extrapolated) = 0.828 W/kg  
**SAR(1 g) = 0.495 W/kg**

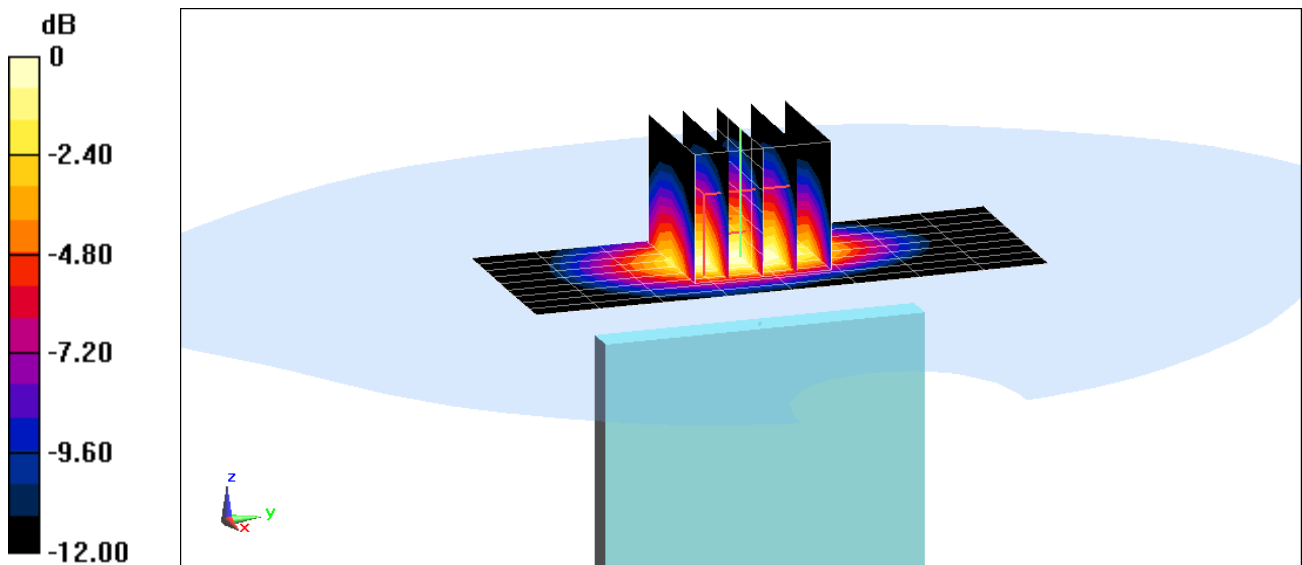

# PCTEST ENGINEERING LABORATORY, INC.

**DUT: A3LSMJ530F; Type: Portable Handset; Serial: 29828**

Communication System: UID 0, UMTS; Frequency: 836.6 MHz; Duty Cycle: 1:1  
Medium: 835 Body Medium parameters used (interpolated):  
 $f = 836.6 \text{ MHz}$ ;  $\sigma = 0.993 \text{ S/m}$ ;  $\epsilon_r = 54.06$ ;  $\rho = 1000 \text{ kg/m}^3$   
Phantom section: Flat Section; Space: 1.5 cm

Test Date: 03-27-2017; Ambient Temp: 21.4°C; Tissue Temp: 21.5°C

Probe: ES3DV3 - SN3318; ConvF(6.37, 6.37, 6.37); Calibrated: 2/10/2017;  
Sensor-Surface: 3mm (Mechanical Surface Detection)  
Electronics: DAE4 Sn665; Calibrated: 2/9/2017  
Phantom: SAM with CRP (Left); Type: SAM; Serial: 1715  
Measurement SW: DASY52, Version 52.8 (8); SEMCAD X Version 14.6.10 (7331)

**Mode: UMTS 850, Body SAR, Back Side, Mid.ch**

**Area Scan (9x15x1):** Measurement grid: dx=15mm, dy=15mm

**Zoom Scan (5x5x7)/Cube 0:** Measurement grid: dx=8mm, dy=8mm, dz=5mm

Reference Value = 16.73 V/m; Power Drift = -0.03 dB

Peak SAR (extrapolated) = 0.337 W/kg

**SAR(1 g) = 0.253 W/kg**

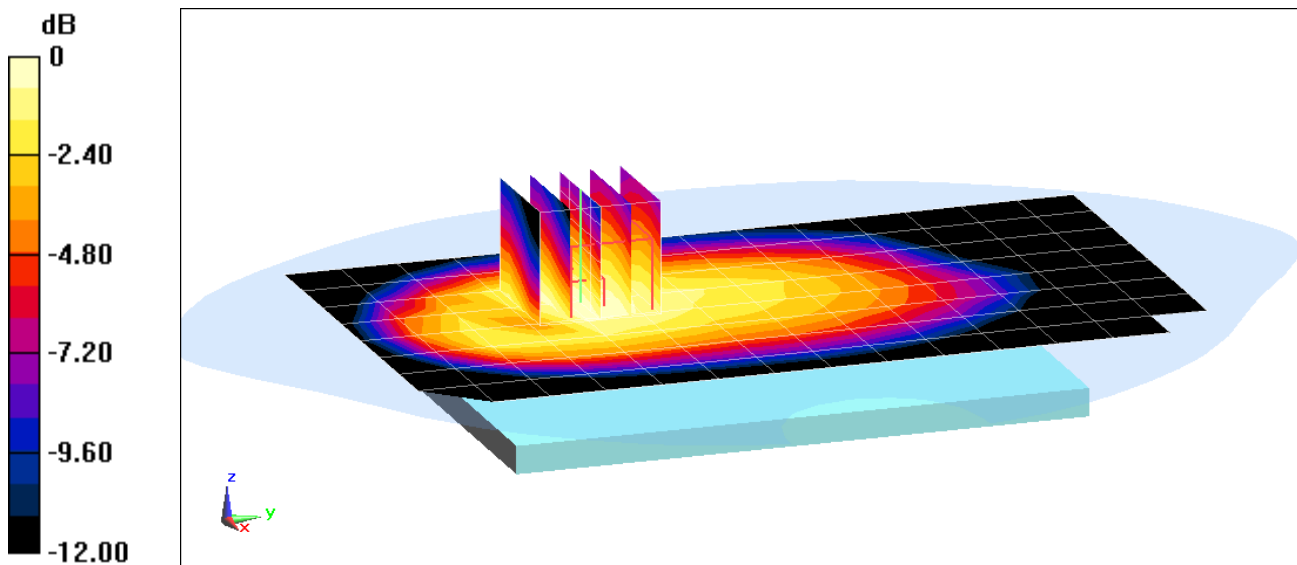

0 dB = 0.284 W/kg = -5.47 dBW/kg

# PCTEST ENGINEERING LABORATORY, INC.

**DUT: A3LSMJ530F; Type: Portable Handset; Serial: 29828**

Communication System: UID 0, UMTS; Frequency: 836.6 MHz; Duty Cycle: 1:1  
Medium: 835 Body Medium parameters used (interpolated):  
 $f = 836.6 \text{ MHz}$ ;  $\sigma = 0.993 \text{ S/m}$ ;  $\epsilon_r = 54.06$ ;  $\rho = 1000 \text{ kg/m}^3$   
Phantom section: Flat Section; Space: 1.0 cm

Test Date: 03-27-2017; Ambient Temp: 21.4°C; Tissue Temp: 21.5°C

Probe: ES3DV3 - SN3318; ConvF(6.37, 6.37, 6.37); Calibrated: 2/10/2017;  
Sensor-Surface: 3mm (Mechanical Surface Detection)  
Electronics: DAE4 Sn665; Calibrated: 2/9/2017  
Phantom: SAM with CRP (Left); Type: SAM; Serial: 1715  
Measurement SW: DASY52, Version 52.8 (8); SEMCAD X Version 14.6.10 (7331)

**Mode: UMTS 850, Body SAR, Back Side, Mid.ch**

**Area Scan (9x15x1):** Measurement grid: dx=15mm, dy=15mm

**Zoom Scan (6x6x7)/Cube 0:** Measurement grid: dx=8mm, dy=8mm, dz=5mm

Reference Value = 19.95 V/m; Power Drift = -0.05 dB

Peak SAR (extrapolated) = 0.645 W/kg

**SAR(1 g) = 0.359 W/kg**

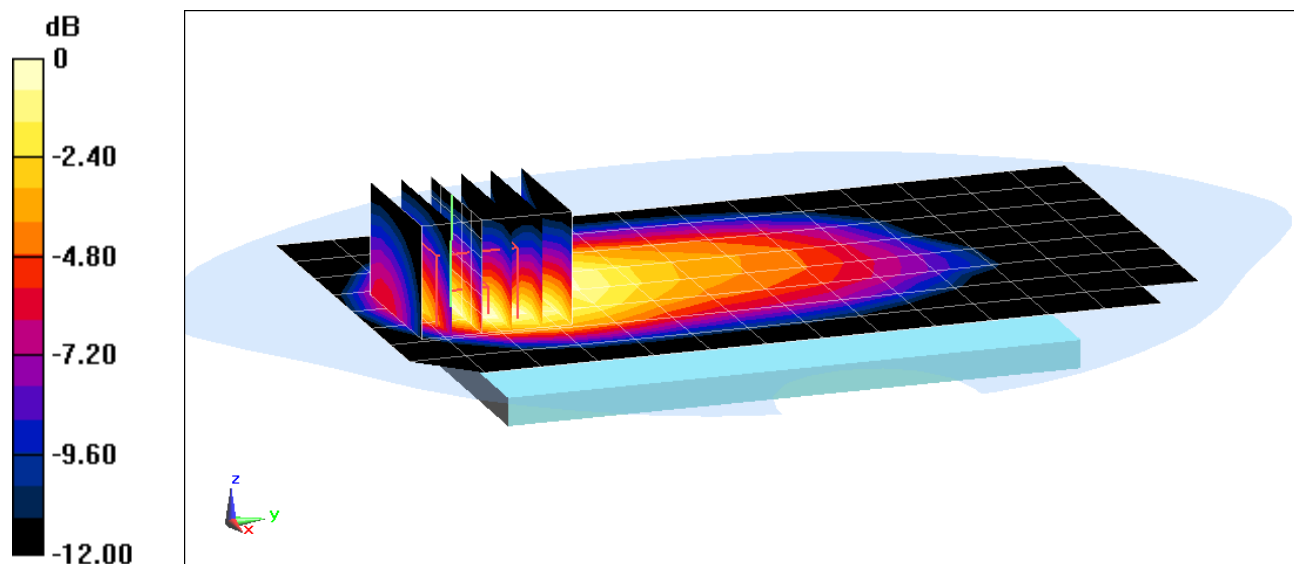

0 dB = 0.446 W/kg = -3.51 dBW/kg

# PCTEST ENGINEERING LABORATORY, INC.

**DUT: A3LSMJ530F; Type: Portable Handset; Serial: 29828**

Communication System: UID 0, UMTS; Frequency: 1732.4 MHz; Duty Cycle: 1:1  
Medium: 1750 Body Medium parameters used (interpolated):  
 $f = 1732.4 \text{ MHz}$ ;  $\sigma = 1.454 \text{ S/m}$ ;  $\epsilon_r = 52.484$ ;  $\rho = 1000 \text{ kg/m}^3$   
Phantom section: Flat Section; Space: 1.5 cm

Test Date: 04-05-2017; Ambient Temp: 24.0°C; Tissue Temp: 23.0°C

Probe: ES3DV3 - SN3213; ConvF(5.09, 5.09, 5.09); Calibrated: 2/10/2017;  
Sensor-Surface: 3mm (Mechanical Surface Detection)  
Electronics: DAE4 Sn1272; Calibrated: 2/9/2017  
Phantom: SAM Right; Type: SAM; Serial: 1757  
Measurement SW: DASY52, Version 52.8 (8); SEMCAD X Version 14.6.10 (7331)

**Mode: UMTS 1750, Body SAR, Back Side, Mid.ch**

**Area Scan (9x15x1):** Measurement grid: dx=15mm, dy=15mm

**Zoom Scan (5x5x7)/Cube 0:** Measurement grid: dx=8mm, dy=8mm, dz=5mm

Reference Value = 18.87 V/m; Power Drift = 0.03 dB

Peak SAR (extrapolated) = 0.699 W/kg

**SAR(1 g) = 0.457 W/kg**

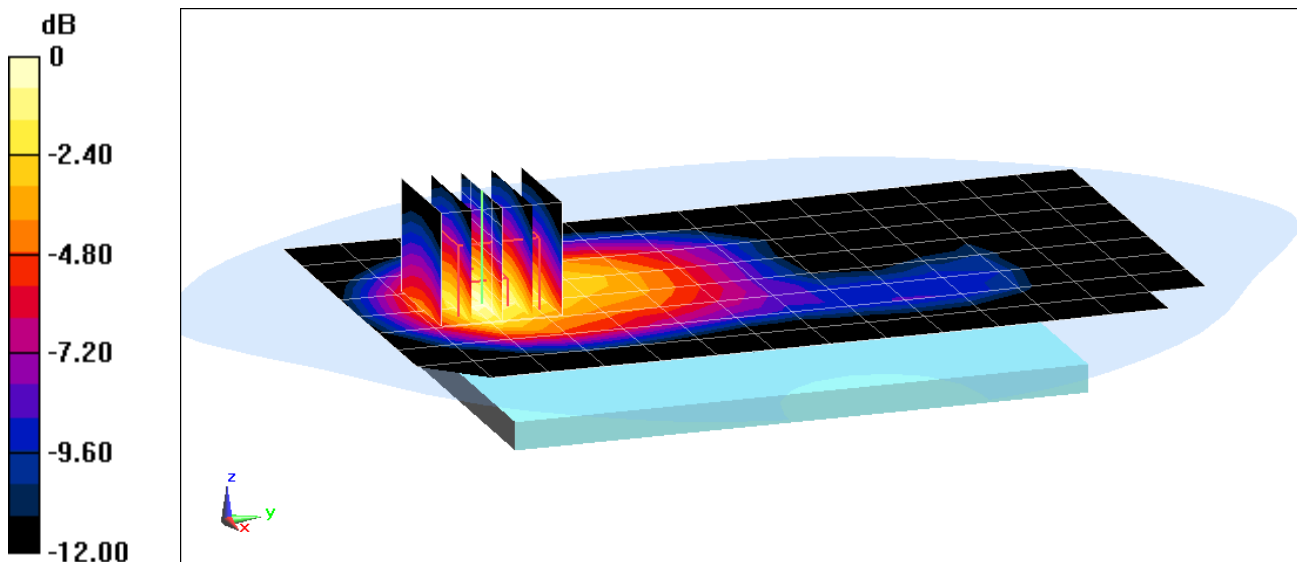

0 dB = 0.546 W/kg = -2.63 dBW/kg

# PCTEST ENGINEERING LABORATORY, INC.

**DUT: A3LSMJ530F; Type: Portable Handset; Serial: 29828**

Communication System: UID 0, UMTS; Frequency: 1732.4 MHz; Duty Cycle: 1:1  
Medium: 1750 Body Medium parameters used (interpolated):  
 $f = 1732.4 \text{ MHz}$ ;  $\sigma = 1.454 \text{ S/m}$ ;  $\epsilon_r = 52.484$ ;  $\rho = 1000 \text{ kg/m}^3$   
Phantom section: Flat Section; Space: 1.0 cm

Test Date: 04-05-2017; Ambient Temp: 24.0°C; Tissue Temp: 23.0°C

Probe: ES3DV3 - SN3213; ConvF(5.09, 5.09, 5.09); Calibrated: 2/10/2017;  
Sensor-Surface: 3mm (Mechanical Surface Detection)  
Electronics: DAE4 Sn1272; Calibrated: 2/9/2017  
Phantom: SAM Right; Type: SAM; Serial: 1757  
Measurement SW: DASY52, Version 52.8 (8); SEMCAD X Version 14.6.10 (7331)

**Mode: UMTS 1750, Body SAR, Back Side, Mid.ch**

**Area Scan (9x15x1):** Measurement grid: dx=15mm, dy=15mm

**Zoom Scan (5x5x7)/Cube 0:** Measurement grid: dx=8mm, dy=8mm, dz=5mm

Reference Value = 22.82 V/m; Power Drift = -0.04 dB

Peak SAR (extrapolated) = 1.04 W/kg

**SAR(1 g) = 0.653 W/kg**

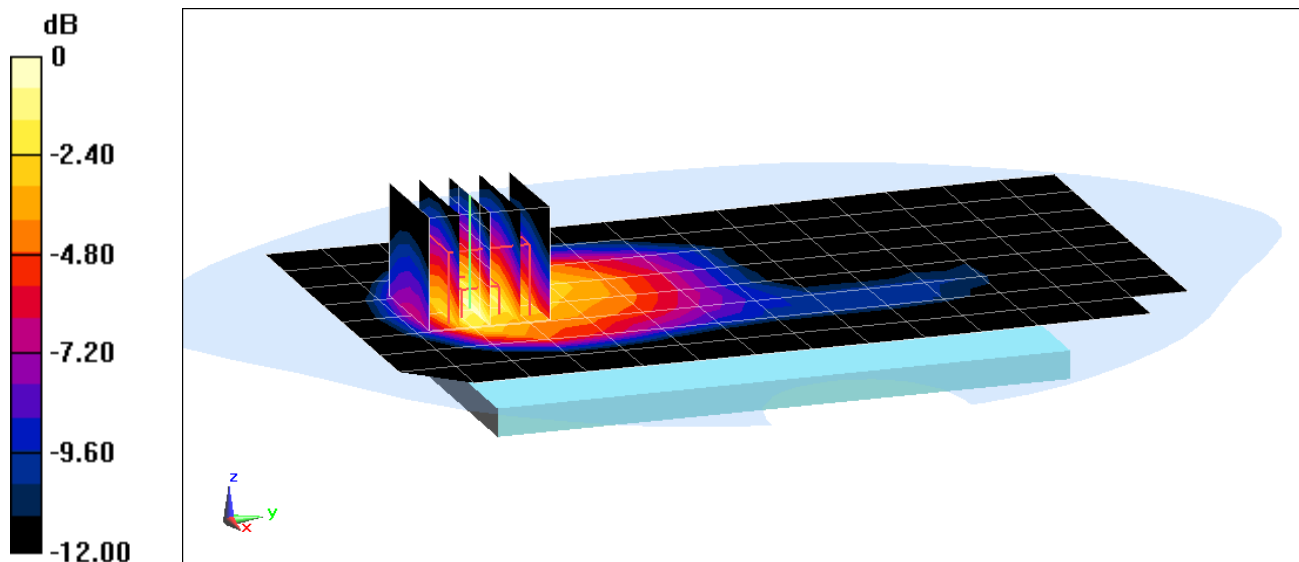

0 dB = 0.799 W/kg = -0.97 dBW/kg

# PCTEST ENGINEERING LABORATORY, INC.

**DUT: A3LSMJ530F; Type: Portable Handset; Serial: 29828**

Communication System: UID 0, UMTS; Frequency: 1852.4 MHz, Frequency: 1907.6 MHz; Duty Cycle: 1:1  
Medium: 1900 Body Medium parameters used (interpolated):  
 $f = 1907.6 \text{ MHz}$ ;  $\sigma = 1.581 \text{ S/m}$ ;  $\epsilon_r = 52.293$ ;  $\rho = 1000 \text{ kg/m}^3$   
Phantom section: Flat Section; Space: 1.5 cm

Test Date: 03-27-2017; Ambient Temp: 21.8°C; Tissue Temp: 22.3°C

Probe: ES3DV3 - SN3287; ConvF(4.94, 4.94, 4.94); Calibrated: 9/19/2016;  
Sensor-Surface: 3mm (Mechanical Surface Detection)  
Electronics: DAE4 Sn1408; Calibrated: 9/14/2016  
Phantom: SAM Front; Type: SAM; Serial: 1686  
Measurement SW: DASY52, Version 52.8 (8); SEMCAD X Version 14.6.10 (7331)

**Mode: UMTS 1900, Body SAR, Back Side, High.ch**

**Area Scan (9x15x1):** Measurement grid: dx=15mm, dy=15mm

**Zoom Scan (5x5x7)/Cube 0:** Measurement grid: dx=8mm, dy=8mm, dz=5mm

Reference Value = 24.22 V/m; Power Drift = 0.02 dB

Peak SAR (extrapolated) = 1.32 W/kg

**SAR(1 g) = 0.814 W/kg**

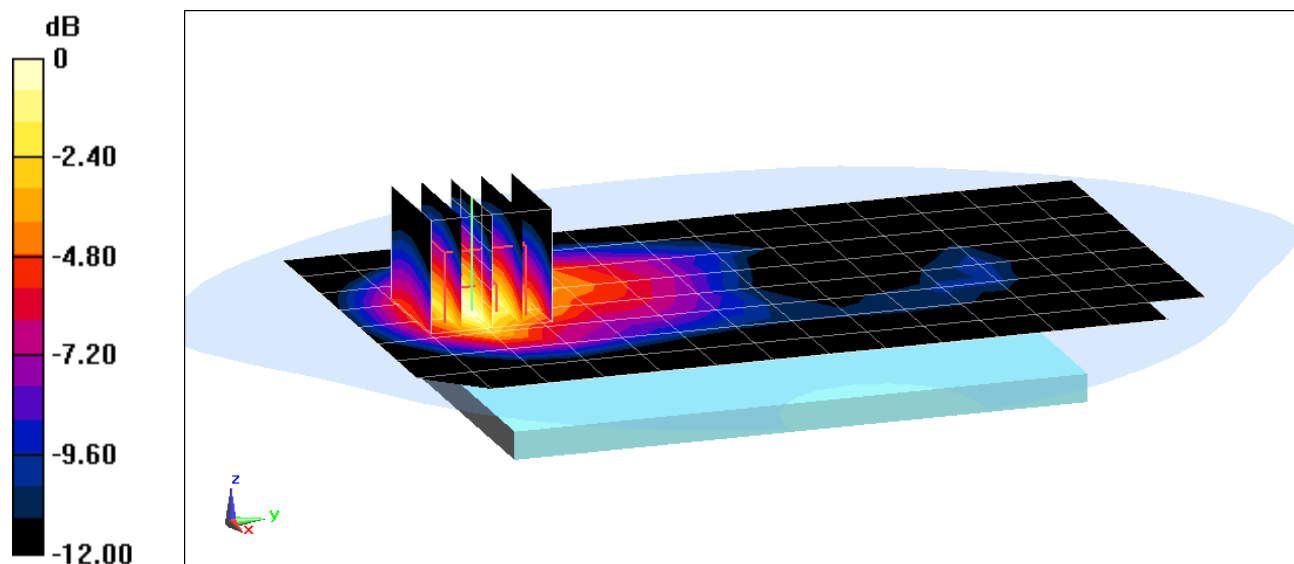

0 dB = 0.980 W/kg = -0.09 dBW/kg

# PCTEST ENGINEERING LABORATORY, INC.

**DUT: A3LSMJ530F; Type: Portable Handset; Serial: 29828**

Communication System: UID 0, UMTS; Frequency: 1852.4 MHz; Duty Cycle: 1:1  
Medium: 1900 Body Medium parameters used (interpolated):  
 $f = 1852.4 \text{ MHz}$ ;  $\sigma = 1.52 \text{ S/m}$ ;  $\epsilon_r = 52.522$ ;  $\rho = 1000 \text{ kg/m}^3$   
Phantom section: Flat Section; Space: 1.0 cm

Test Date: 03-27-2017; Ambient Temp: 21.8°C; Tissue Temp: 22.3°C

Probe: ES3DV3 - SN3287; ConvF(4.94, 4.94, 4.94); Calibrated: 9/19/2016;  
Sensor-Surface: 3mm (Mechanical Surface Detection)  
Electronics: DAE4 Sn1408; Calibrated: 9/14/2016  
Phantom: SAM Front; Type: SAM; Serial: 1686  
Measurement SW: DASY52, Version 52.8 (8); SEMCAD X Version 14.6.10 (7331)

**Mode: UMTS 1900, Body SAR, Back Side, Low.ch**

**Area Scan (9x15x1):** Measurement grid: dx=15mm, dy=15mm

**Zoom Scan (5x5x7)/Cube 0:** Measurement grid: dx=8mm, dy=8mm, dz=5mm

Reference Value = 25.43 V/m; Power Drift = -0.07 dB

Peak SAR (extrapolated) = 1.35 W/kg

**SAR(1 g) = 0.831 W/kg**

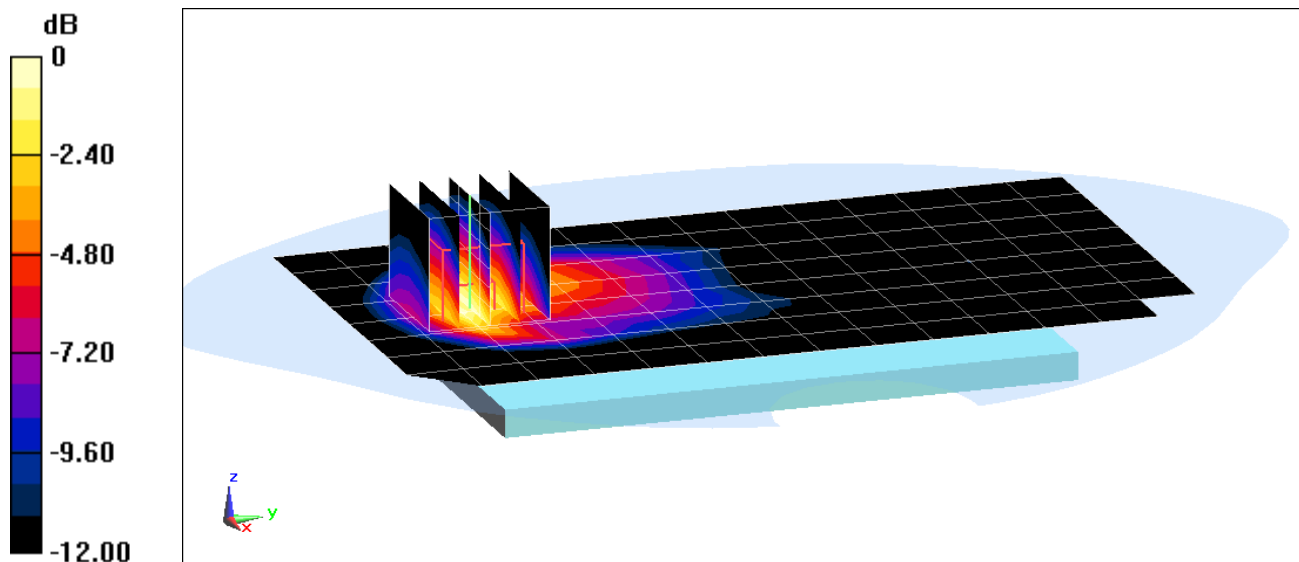

0 dB = 1.02 W/kg = 0.09 dBW/kg

# PCTEST ENGINEERING LABORATORY, INC.

**DUT: A3LSMJ530F; Type: Portable Handset; Serial: 29828**

Communication System: UID 0, LTE Band 5; Frequency: 836.5 MHz; Duty Cycle: 1:1  
Medium: 835 Body Medium parameters used (interpolated):  
 $f = 836.5 \text{ MHz}$ ;  $\sigma = 0.993 \text{ S/m}$ ;  $\epsilon_r = 54.061$ ;  $\rho = 1000 \text{ kg/m}^3$   
Phantom section: Flat Section; Space: 1.5 cm

Test Date: 03-27-2017; Ambient Temp: 21.4°C; Tissue Temp: 21.5°C

Probe: ES3DV3 - SN3318; ConvF(6.37, 6.37, 6.37); Calibrated: 2/10/2017;  
Sensor-Surface: 3mm (Mechanical Surface Detection)  
Electronics: DAE4 Sn665; Calibrated: 2/9/2017  
Phantom: SAM with CRP (Left); Type: SAM; Serial: 1715  
Measurement SW: DASY52, Version 52.8 (8); SEMCAD X Version 14.6.10 (7331)

**Mode: LTE Band 5 (Cell.), Body SAR, Back Side, Mid.ch, 10 MHz Bandwidth,  
QPSK, 1 RB, 25 RB Offset**

**Area Scan (9x15x1):** Measurement grid:  $dx=15\text{mm}$ ,  $dy=15\text{mm}$

**Zoom Scan (5x5x7)/Cube 0:** Measurement grid:  $dx=8\text{mm}$ ,  $dy=8\text{mm}$ ,  $dz=5\text{mm}$

Reference Value = 18.45 V/m; Power Drift = -0.04 dB

Peak SAR (extrapolated) = 0.413 W/kg

**SAR(1 g) = 0.311 W/kg**

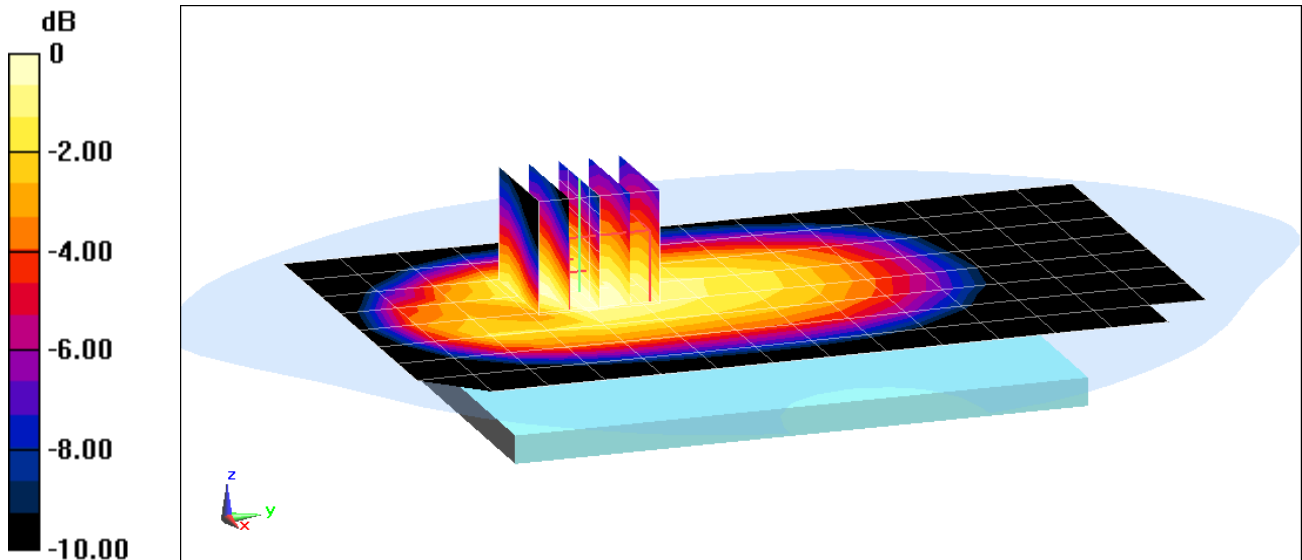

0 dB = 0.345 W/kg = -4.62 dBW/kg

# PCTEST ENGINEERING LABORATORY, INC.

**DUT: A3LSMJ530F; Type: Portable Handset; Serial: 29828**

Communication System: UID 0, LTE Band 5; Frequency: 836.5 MHz; Duty Cycle: 1:1  
Medium: 835 Body Medium parameters used (interpolated):  
 $f = 836.5 \text{ MHz}$ ;  $\sigma = 0.993 \text{ S/m}$ ;  $\epsilon_r = 54.061$ ;  $\rho = 1000 \text{ kg/m}^3$   
Phantom section: Flat Section; Space: 1.0 cm

Test Date: 03-27-2017; Ambient Temp: 21.4°C; Tissue Temp: 21.5°C

Probe: ES3DV3 - SN3318; ConvF(6.37, 6.37, 6.37); Calibrated: 2/10/2017;  
Sensor-Surface: 3mm (Mechanical Surface Detection)  
Electronics: DAE4 Sn665; Calibrated: 2/9/2017  
Phantom: SAM with CRP (Left); Type: SAM; Serial: 1715  
Measurement SW: DASY52, Version 52.8 (8); SEMCAD X Version 14.6.10 (7331)

**Mode: LTE Band 5 (Cell.), Body SAR, Back Side, Mid.ch, 10 MHz Bandwidth,  
QPSK, 1 RB, 25 RB Offset**

**Area Scan (9x15x1):** Measurement grid: dx=15mm, dy=15mm

**Zoom Scan (6x6x7)/Cube 0:** Measurement grid: dx=8mm, dy=8mm, dz=5mm

Reference Value = 20.76 V/m; Power Drift = -0.05 dB

Peak SAR (extrapolated) = 0.696 W/kg

**SAR(1 g) = 0.390 W/kg**

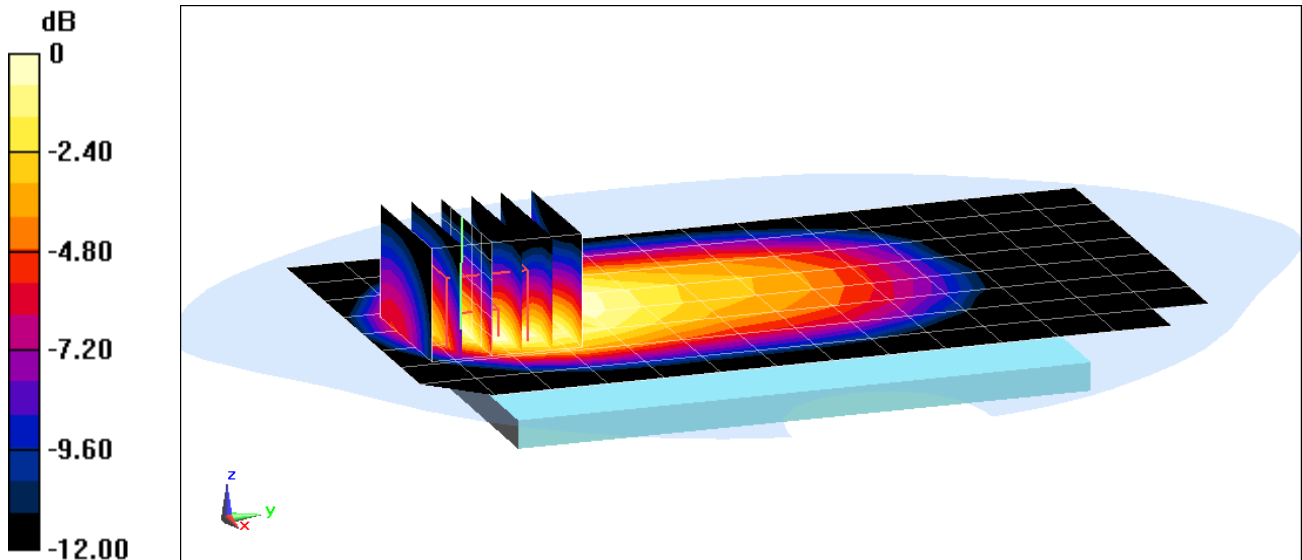

0 dB = 0.484 W/kg = -3.15 dBW/kg

# PCTEST ENGINEERING LABORATORY, INC.

**DUT: A3LSMJ530F; Type: Portable Handset; Serial: 29752**

Communication System: UID 0, IEEE 802.11b; Frequency: 2437 MHz; Duty Cycle: 1:1  
Medium: 2450 Body Medium parameters used (interpolated):  
 $f = 2437 \text{ MHz}$ ;  $\sigma = 1.989 \text{ S/m}$ ;  $\epsilon_r = 51.848$ ;  $\rho = 1000 \text{ kg/m}^3$   
Phantom section: Flat Section; Space: 1.5 cm

Test Date: 03-23-2017; Ambient Temp: 22.3°C; Tissue Temp: 22.0°C

Probe: EX3DV4 - SN7406; ConvF(7.24, 7.24, 7.24); Calibrated: 4/19/2016;  
Sensor-Surface: 1.4mm (Mechanical Surface Detection)  
Electronics: DAE4 Sn1407; Calibrated: 4/14/2016

Phantom: SAM 5.0 front; Type: QD000P40CD; Serial: TP:-1648  
Measurement SW: DASY52, Version 52.8 (8); SEMCAD X Version 14.6.10 (7331)

**Mode: IEEE 802.11b, 22 MHz Bandwidth, Body SAR, Back Side, Ch 6, 1 Mbps**

**Area Scan (11x17x1):** Measurement grid: dx=12mm, dy=12mm

**Zoom Scan (7x7x7)/Cube 0:** Measurement grid: dx=5mm, dy=5mm, dz=5mm

Reference Value = 7.919 V/m; Power Drift = 0.11 dB

Peak SAR (extrapolated) = 0.214 W/kg

**SAR(1 g) = 0.112 W/kg**

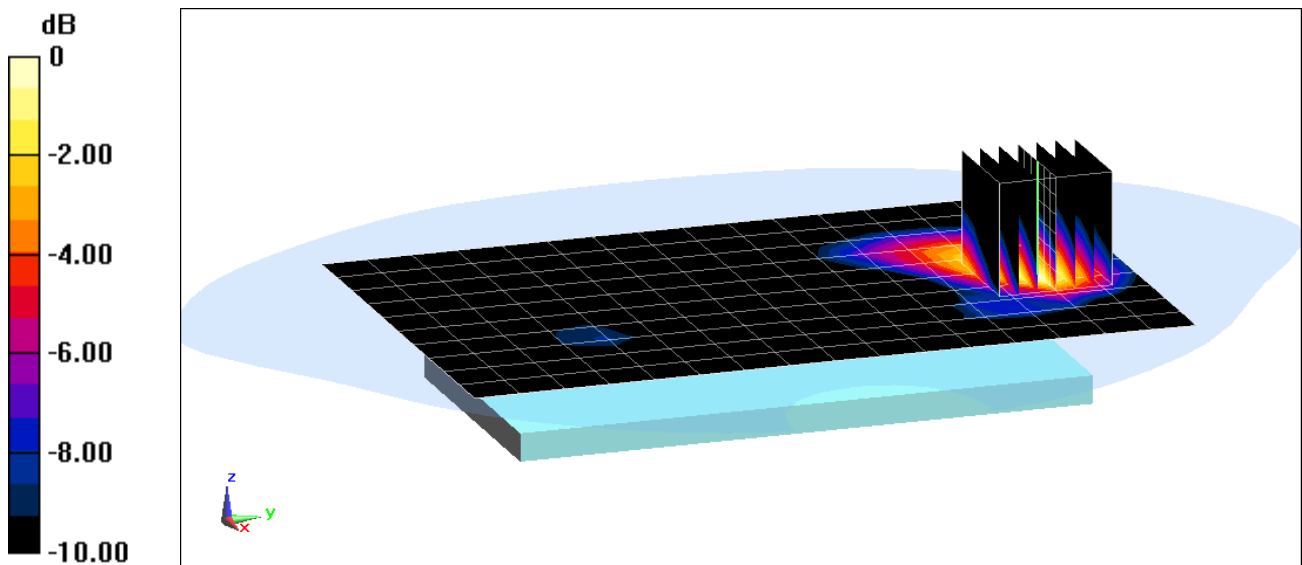

# PCTEST ENGINEERING LABORATORY, INC.

**DUT: A3LSMJ530F; Type: Portable Handset; Serial: 29752**

Communication System: UID 0, IEEE 802.11b; Frequency: 2437 MHz; Duty Cycle: 1:1  
Medium: 2450 Body Medium parameters used (interpolated):  
 $f = 2437 \text{ MHz}$ ;  $\sigma = 1.995 \text{ S/m}$ ;  $\epsilon_r = 51.029$ ;  $\rho = 1000 \text{ kg/m}^3$   
Phantom section: Flat Section; Space: 1.0 cm

Test Date: 03-29-2017; Ambient Temp: 23.5°C; Tissue Temp: 22.1°C

Probe: EX3DV4 - SN7406; ConvF(7.24, 7.24, 7.24); Calibrated: 4/19/2016;  
Sensor-Surface: 1.4mm (Mechanical Surface Detection)  
Electronics: DAE4 Sn1407; Calibrated: 4/14/2016

Phantom: SAM 5.0 front; Type: QD000P40CD; Serial: TP:-1648  
Measurement SW: DASY52, Version 52.8 (8); SEMCAD X Version 14.6.10 (7331)

**Mode: IEEE 802.11b, 22 MHz Bandwidth, Body SAR, Top Edge, Ch 6, 1 Mbps**

**Area Scan (10x9x1):** Measurement grid: dx=5mm, dy=12mm

**Zoom Scan (7x7x7)/Cube 0:** Measurement grid: dx=5mm, dy=5mm, dz=5mm

Reference Value = 11.55 V/m; Power Drift = 0.10 dB

Peak SAR (extrapolated) = 0.487 W/kg

**SAR(1 g) = 0.244 W/kg**

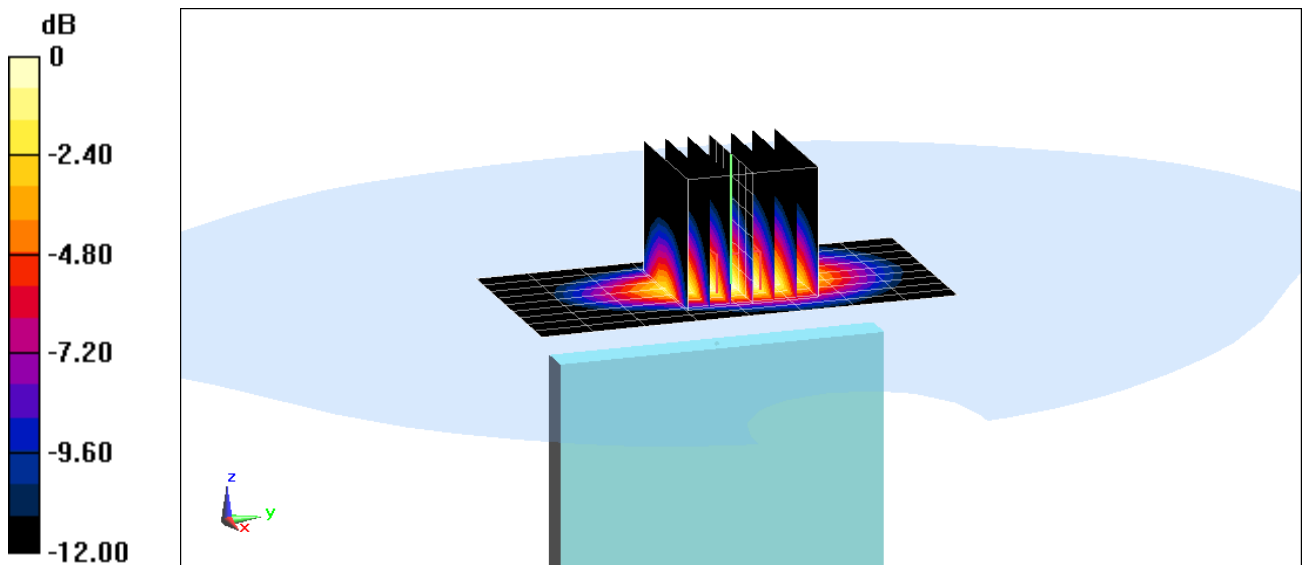

# PCTEST ENGINEERING LABORATORY, INC.

**DUT: A3LSMJ530F; Type: Portable Handset; Serial: 74902**

Communication System: UID 0, 802.11a 5.2-5.8 GHz Band; Frequency: 5745 MHz; Duty Cycle: 1:1

Medium: 5GHz Body Medium parameters used:

$f = 5745 \text{ MHz}$ ;  $\sigma = 6.198 \text{ S/m}$ ;  $\epsilon_r = 46.289$ ;  $\rho = 1000 \text{ kg/m}^3$

Phantom section: Flat Section; Space: 1.5 cm

Test Date: 03-20-2017; Ambient Temp: 23.1°C; Tissue Temp: 21.0°C

Probe: EX3DV4 - SN7308; ConvF(4.04, 4.04, 4.04); Calibrated: 7/21/2016;

Sensor-Surface: 1.4mm (Mechanical Surface Detection)

Electronics: DAE4 Sn859; Calibrated: 5/11/2016

Phantom: SAM Left; Type: QD000P40CC; Serial: TP: 1375

Measurement SW: DASY52, Version 52.8 (8); SEMCAD X Version 14.6.10 (7331)

**Mode: IEEE 802.11a, UNII-3, 20 MHz Bandwidth, Body SAR, Ch 149, 6 Mbps, Back Side**

**Area Scan (11x19x1):** Measurement grid: dx=10mm, dy=10mm

**Zoom Scan (7x7x7)/Cube 0:** Measurement grid: dx=4mm, dy=4mm, dz=1.4mm; Graded Ratio: 1.4

Reference Value = 3.590 V/m; Power Drift = 0.12 dB

Peak SAR (extrapolated) = 0.243 W/kg

**SAR(1 g) = 0.069 W/kg**

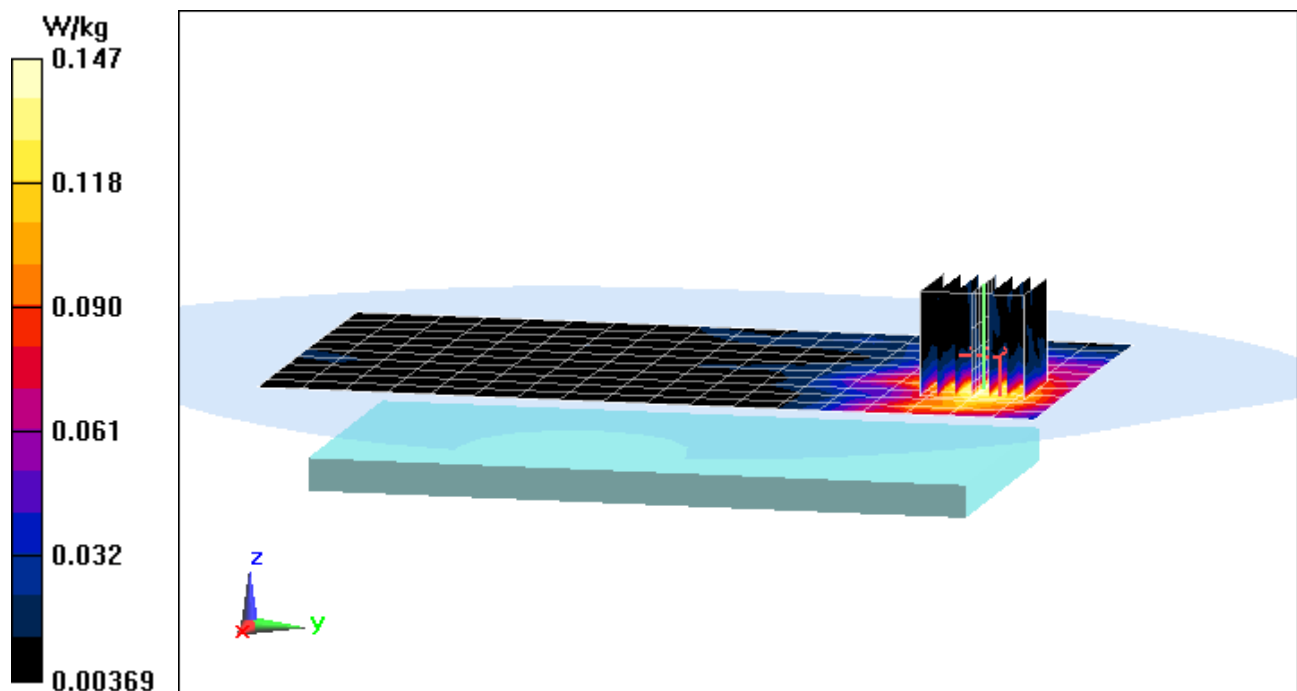

# PCTEST ENGINEERING LABORATORY, INC.

**DUT: A3LSMJ530F; Type: Portable Handset; Serial: 74902**

Communication System: UID 0, 802.11a 5.2-5.8 GHz Band; Frequency: 5745 MHz; Duty Cycle: 1:1  
Medium: 5GHz Body Medium parameters used:  
 $f = 5745 \text{ MHz}$ ;  $\sigma = 6.198 \text{ S/m}$ ;  $\epsilon_r = 46.289$ ;  $\rho = 1000 \text{ kg/m}^3$   
Phantom section: Flat Section; Space: 1.0 cm

Test Date: 03-20-2017; Ambient Temp: 23.1°C; Tissue Temp: 21.0°C

Probe: EX3DV4 - SN7308; ConvF(4.04, 4.04, 4.04); Calibrated: 7/21/2016;

Sensor-Surface: 1.4mm (Mechanical Surface Detection)

Electronics: DAE4 Sn859; Calibrated: 5/11/2016

Phantom: SAM Left; Type: QD000P40CC; Serial: TP: 1375

Measurement SW: DASY52, Version 52.8 (8); SEMCAD X Version 14.6.10 (7331)

**Mode: IEEE 802.11a, UNII-3, 20 MHz Bandwidth, Body SAR, Ch 149, 6 Mbps, Front Side**

**Area Scan (12x21x1):** Measurement grid: dx=10mm, dy=10mm

**Zoom Scan (7x7x7)/Cube 0:** Measurement grid: dx=4mm, dy=4mm, dz=1.4mm; Graded Ratio: 1.4

Reference Value = 3.095 V/m; Power Drift = 0.13 dB

Peak SAR (extrapolated) = 3.31 W/kg

**SAR(1 g) = 0.828 W/kg**

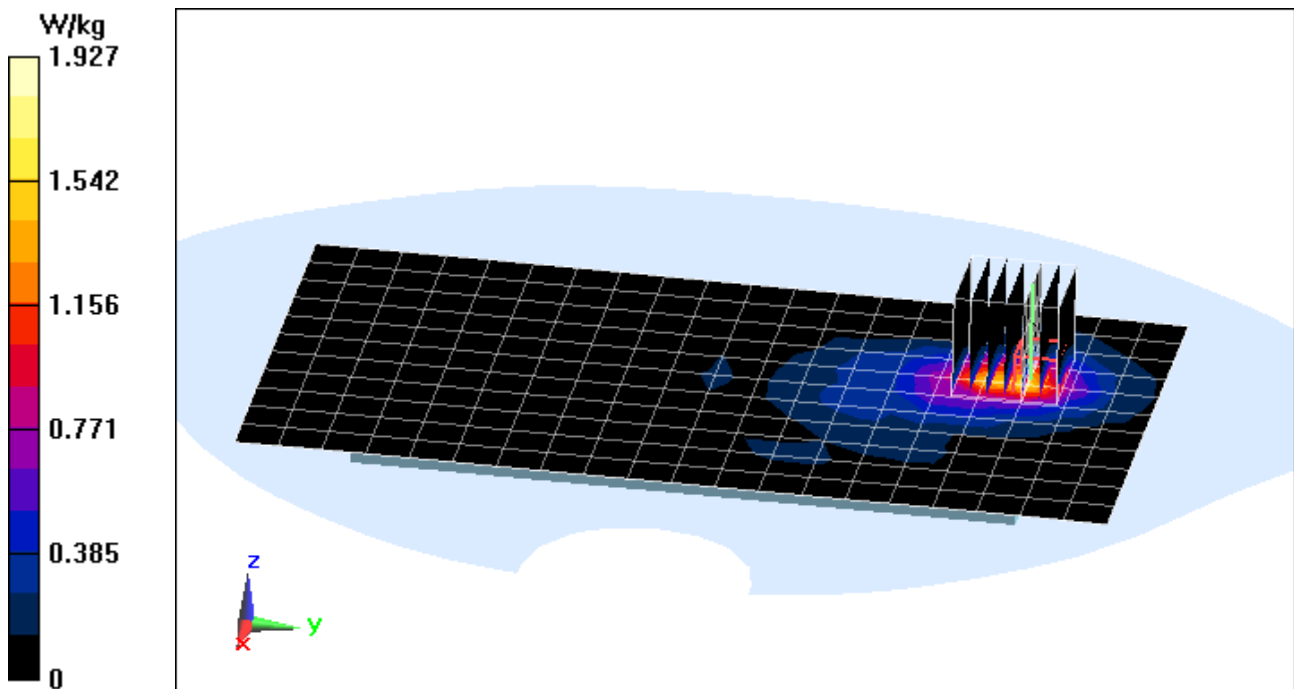

## APPENDIX B: SYSTEM VERIFICATION

# PCTEST ENGINEERING LABORATORY, INC.

**DUT: Dipole 835 MHz; Type: D835V2; Serial: 4d047**

Communication System: UID 0, CW; Frequency: 835 MHz; Duty Cycle: 1:1

Medium: 835 Head Medium parameters used:

$f = 835 \text{ MHz}$ ;  $\sigma = 0.896 \text{ S/m}$ ;  $\epsilon_r = 40.456$ ;  $\rho = 1000 \text{ kg/m}^3$

Phantom section: Flat Section; Space: 1.5 cm

Test Date: 03-20-2017; Ambient Temp: 22.3°C; Tissue Temp: 20.5°C

Probe: EX3DV4 - SN7406; ConvF(9.83, 9.83, 9.83); Calibrated: 04/19/2016;

Sensor-Surface: 1.4mm (Mechanical Surface Detection)

Electronics: DAE4 Sn1407; Calibrated: 04/14/2016

Phantom: SAM V5.0 Right; Type: QD000P40CD; Serial: 1647

Measurement SW: DASY52, Version 52.8 (8); SEMCAD X Version 14.6.10 (7331)

## 835 MHz System Verification at 23.0 dBm (200 mW)

**Area Scan (7x14x1):** Measurement grid: dx=15mm, dy=15mm

**Zoom Scan (5x5x7)/Cube 0:** Measurement grid: dx=8mm, dy=8mm, dz=5mm

Peak SAR (extrapolated) = 2.88 W/kg

**SAR(1 g) = 1.92 W/kg**

Deviation(1 g) = 5.15%;

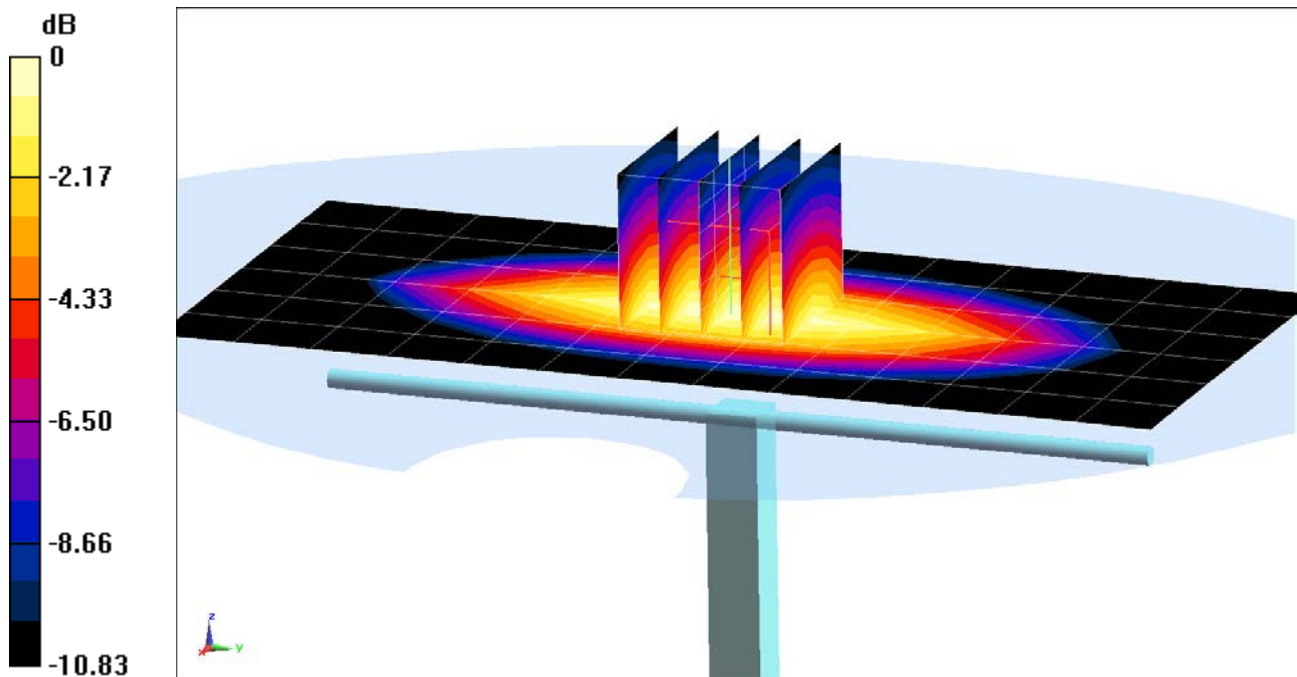

0 dB = 2.57 W/kg = 4.10 dBW/kg

# PCTEST ENGINEERING LABORATORY, INC.

**DUT: Dipole 835 MHz; Type: D835V2; Serial: 4d047**

Communication System: UID 0, CW; Frequency: 835 MHz; Duty Cycle: 1:1

Medium: 835 Head Medium parameters used:

$f = 835 \text{ MHz}$ ;  $\sigma = 0.895 \text{ S/m}$ ;  $\epsilon_r = 42.965$ ;  $\rho = 1000 \text{ kg/m}^3$

Phantom section: Flat Section; Space: 1.5 cm

Test Date: 03-22-2017; Ambient Temp: 21.3°C; Tissue Temp: 21.8°C

Probe: ES3DV3 - SN3334; ConvF(6.49, 6.49, 6.49); Calibrated: 11/15/2016;

Sensor-Surface: 3mm (Mechanical Surface Detection)

Electronics: DAE4 Sn1334; Calibrated: 11/11/2016

Phantom: SAM with CRP v4.0; Type: QD000P40CD; Serial: TP:1800

Measurement SW: DASY52, Version 52.8 (8); SEMCAD X Version 14.6.10 (7331)

## 835 MHz System Verification at 23.0 dBm (200 mW)

**Area Scan (7x14x1):** Measurement grid: dx=15mm, dy=15mm

**Zoom Scan (5x5x7)/Cube 0:** Measurement grid: dx=8mm, dy=8mm, dz=5mm

Peak SAR (extrapolated) = 2.79 W/kg

**SAR(1 g) = 1.91 W/kg**

Deviation(1 g) = 4.60%

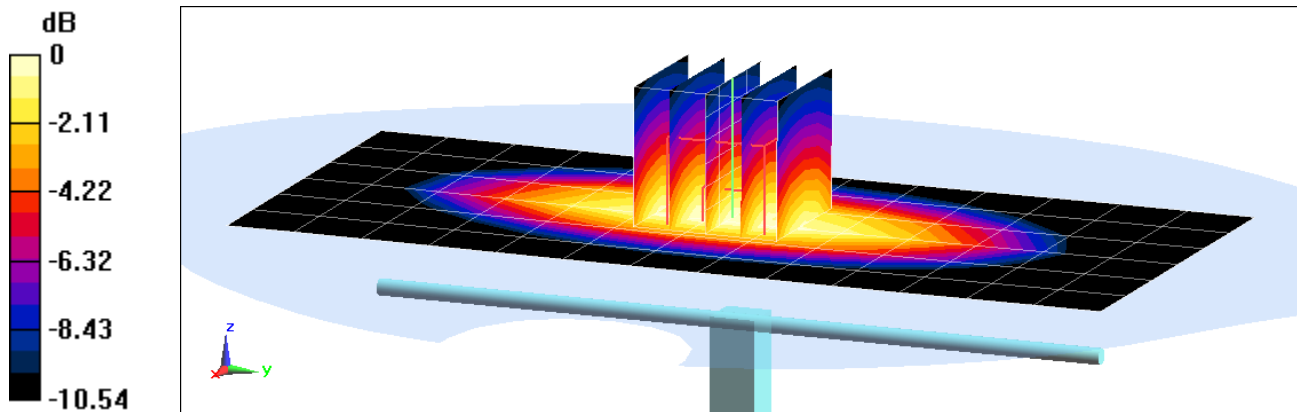

0 dB = 2.22 W/kg = 3.46 dBW/kg

# PCTEST ENGINEERING LABORATORY, INC.

**DUT: Dipole 1750 MHz; Type: D1765V2; Serial: 1008**

Communication System: UID 0, CW; Frequency: 1750 MHz; Duty Cycle: 1:1

Medium: 1750 Head Medium parameters used:

$f = 1750 \text{ MHz}$ ;  $\sigma = 1.338 \text{ S/m}$ ;  $\epsilon_r = 38.95$ ;  $\rho = 1000 \text{ kg/m}^3$

Phantom section: Flat Section; Space: 1.0 cm

Test Date: 03-22-2017; Ambient Temp: 24.1°C; Tissue Temp: 22.0°C

Probe: ES3DV3 - SN3318; ConvF(5.49, 5.49, 5.49); Calibrated: 2/10/2017;

Sensor-Surface: 3mm (Mechanical Surface Detection)

Electronics: DAE4 Sn665; Calibrated: 2/9/2017

Phantom: SAM with CRP v5.0 (Right); Type: QD000P40CD; Serial: TP:1759

Measurement SW: DASY52, Version 52.8 (8); SEMCAD X Version 14.6.10 (7331)

## 1750 MHz System Verification at 20.0 dBm (100 mW)

**Area Scan (7x9x1):** Measurement grid: dx=15mm, dy=15mm

**Zoom Scan (5x5x7)/Cube 0:** Measurement grid: dx=8mm, dy=8mm, dz=5mm

Peak SAR (extrapolated) = 6.33 W/kg

**SAR(1 g) = 3.49 W/kg**

Deviation(1 g) = -4.90%

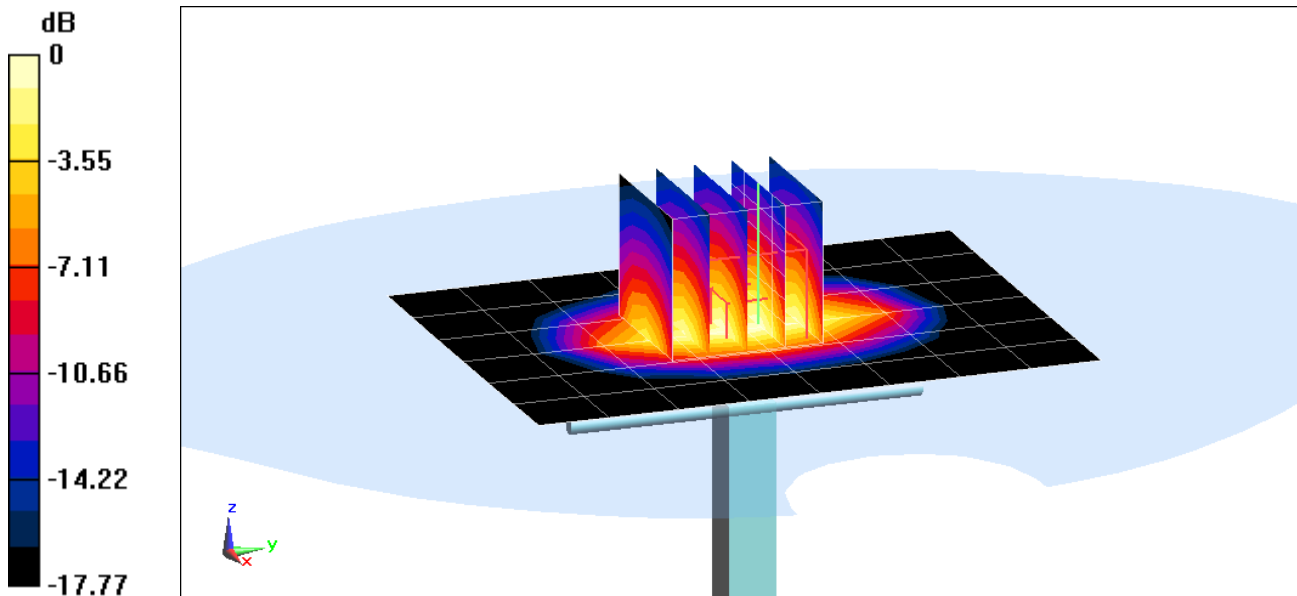

0 dB = 4.34 W/kg = 6.37 dBW/kg

# PCTEST ENGINEERING LABORATORY, INC.

**DUT: Dipole 1900 MHz; Type: D1900V2; Serial: 5d149**

Communication System: UID 0, CW; Frequency: 1900 MHz; Duty Cycle: 1:1

Medium: 1900 Head Medium parameters used (interpolated):

$f = 1900 \text{ MHz}$ ;  $\sigma = 1.45 \text{ S/m}$ ;  $\epsilon_r = 39.369$ ;  $\rho = 1000 \text{ kg/m}^3$

Phantom section: Flat Section; Space: 1.0 cm

Test Date: 03-20-2017; Ambient Temp: 22.0°C; Tissue Temp: 21.3°C

Probe: ES3DV3 - SN3318; ConvF(5.31, 5.31, 5.31); Calibrated: 2/10/2017;

Sensor-Surface: 3mm (Mechanical Surface Detection)

Electronics: DAE4 Sn665; Calibrated: 2/9/2017

Phantom: SAM with CRP (Left); Type: SAM; Serial: 1715

Measurement SW: DASY52, Version 52.8 (8); SEMCAD X Version 14.6.10 (7331)

## 1900 MHz System Verification at 20.0 dBm (100 mW)

**Area Scan (7x10x1):** Measurement grid: dx=15mm, dy=15mm

**Zoom Scan (5x5x7)/Cube 0:** Measurement grid: dx=8mm, dy=8mm, dz=5mm

Peak SAR (extrapolated) = 7.08 W/kg

**SAR(1 g) = 3.87 W/kg**

Deviation(1 g) = -3.49%

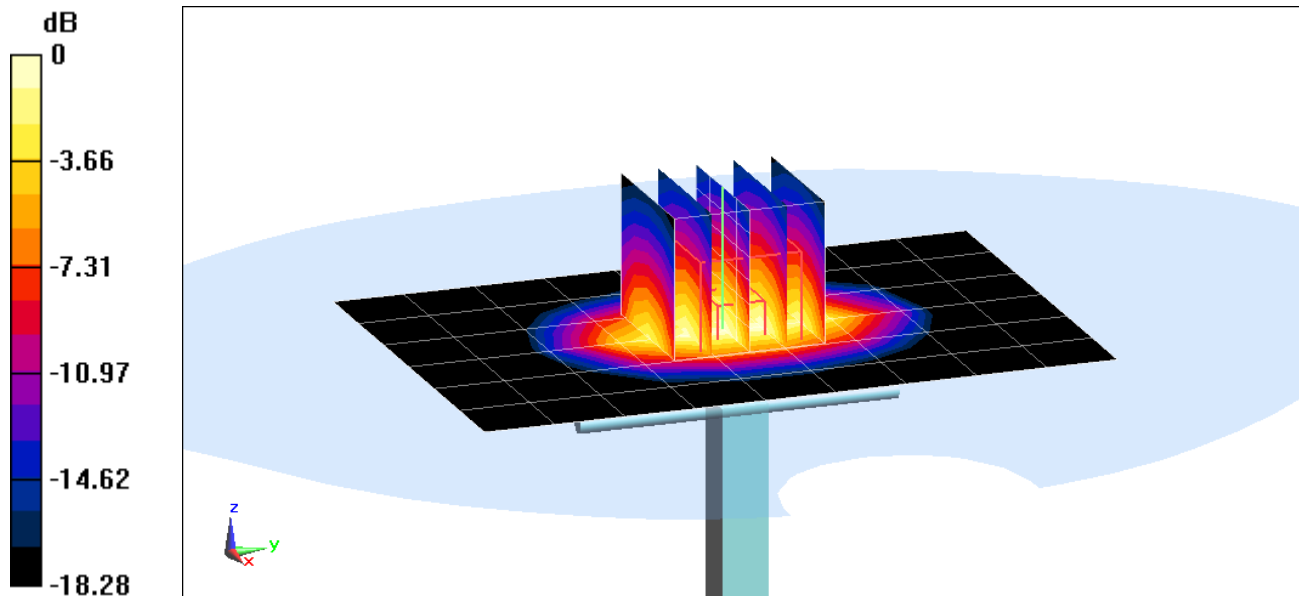

0 dB = 4.90 W/kg = 6.90 dBW/kg

# PCTEST ENGINEERING LABORATORY, INC.

**DUT: Dipole 2450 MHz; Type: D2450V2; Serial: 797**

Communication System: UID 0, CW; Frequency: 2450 MHz; Duty Cycle: 1:1

Medium: 2450 Head Medium parameters used:

$f = 2450 \text{ MHz}$ ;  $\sigma = 1.854 \text{ S/m}$ ;  $\epsilon_r = 37.914$ ;  $\rho = 1000 \text{ kg/m}^3$

Phantom section: Flat Section; Space: 1.0 cm

Test Date: 03-23-2017; Ambient Temp: 21.3°C; Tissue Temp: 22.9°C

Probe: ES3DV3 - SN3287; ConvF(4.54, 4.54, 4.54); Calibrated: 9/19/2016;

Sensor-Surface: 3mm (Mechanical Surface Detection)

Electronics: DAE4 Sn1408; Calibrated: 9/14/2016

Phantom: SAM Left; Type: QD000P40CA; Serial: TP:82355

Measurement SW: DASY52, Version 52.8 (8); SEMCAD X Version 14.6.10 (7331)

## 2450 MHz System Verification at 20.0 dBm (100 mW)

**Area Scan (8x9x1):** Measurement grid: dx=12mm, dy=12mm

**Zoom Scan (7x7x7)/Cube 0:** Measurement grid: dx=5mm, dy=5mm, dz=5mm

Peak SAR (extrapolated) = 11.5 W/kg

**SAR(1 g) = 5.37 W/kg**

Deviation(1 g) = 3.07%

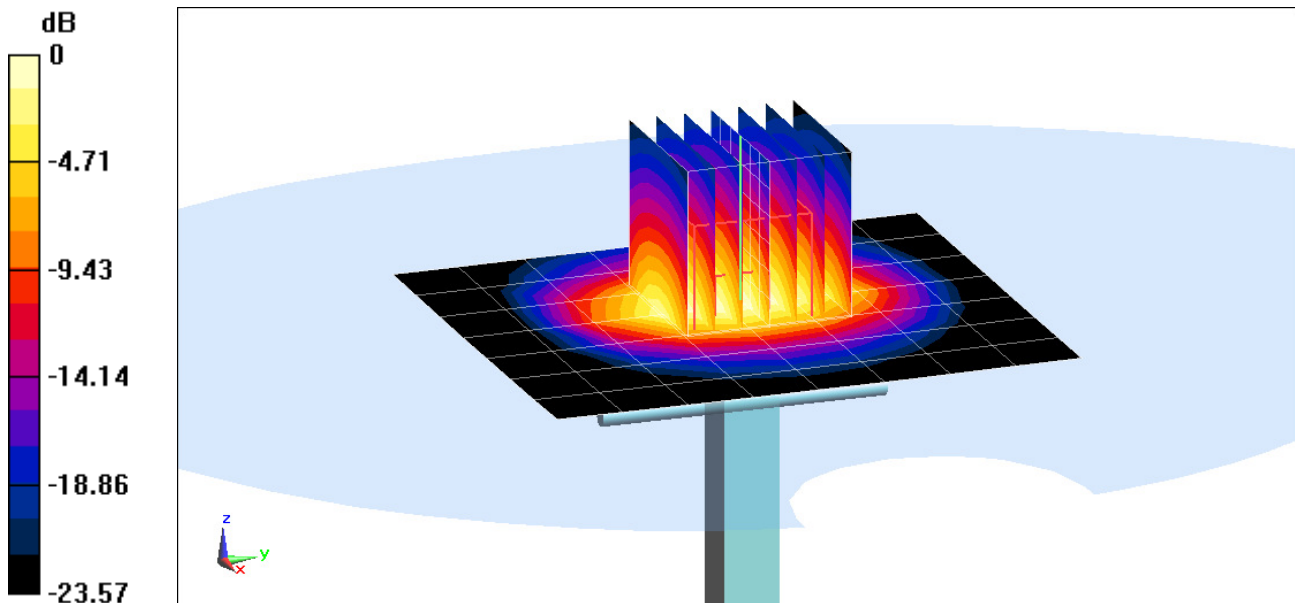

0 dB = 7.06 W/kg = 8.49 dBW/kg

# PCTEST ENGINEERING LABORATORY, INC.

**DUT: Dipole 5 GHz; Type: D5GHzV2; Serial: 1237**

Communication System: UID 0, CW; Frequency: 5250 MHz; Duty Cycle: 1:1

Medium: 5GHz Head Medium parameters used (interpolated):

$f = 5250 \text{ MHz}$ ;  $\sigma = 4.647 \text{ S/m}$ ;  $\epsilon_r = 35.493$ ;  $\rho = 1000 \text{ kg/m}^3$

Phantom section: Flat Section; Space: 1.0 cm

Test Date: 03-27-2017; Ambient Temp: 22.7°C; Tissue Temp: 21.0°C

Probe: EX3DV4 - SN7308; ConvF(5.21, 5.21, 5.21); Calibrated: 7/21/2016;

Sensor-Surface: 1.4mm (Mechanical Surface Detection)

Electronics: DAE4 Sn859; Calibrated: 5/11/2016

Phantom: SAM Left; Type: QD000P40CC; Serial: TP: 1375

Measurement SW: DASY52, Version 52.8 (8); SEMCAD X Version 14.6.10 (7331)

## 5250 MHz System Verification at 17.0 dBm (50 mW)

**Area Scan (7x7x1):** Measurement grid: dx=10mm, dy=10mm

**Zoom Scan (8x8x7)/Cube 0:** Measurement grid: dx=4mm, dy=4mm, dz=1.4mm; Graded Ratio: 1.4

Peak SAR (extrapolated) = 16.9 W/kg

**SAR(1 g) = 3.85 W/kg**

Deviation(1 g) = -2.78%

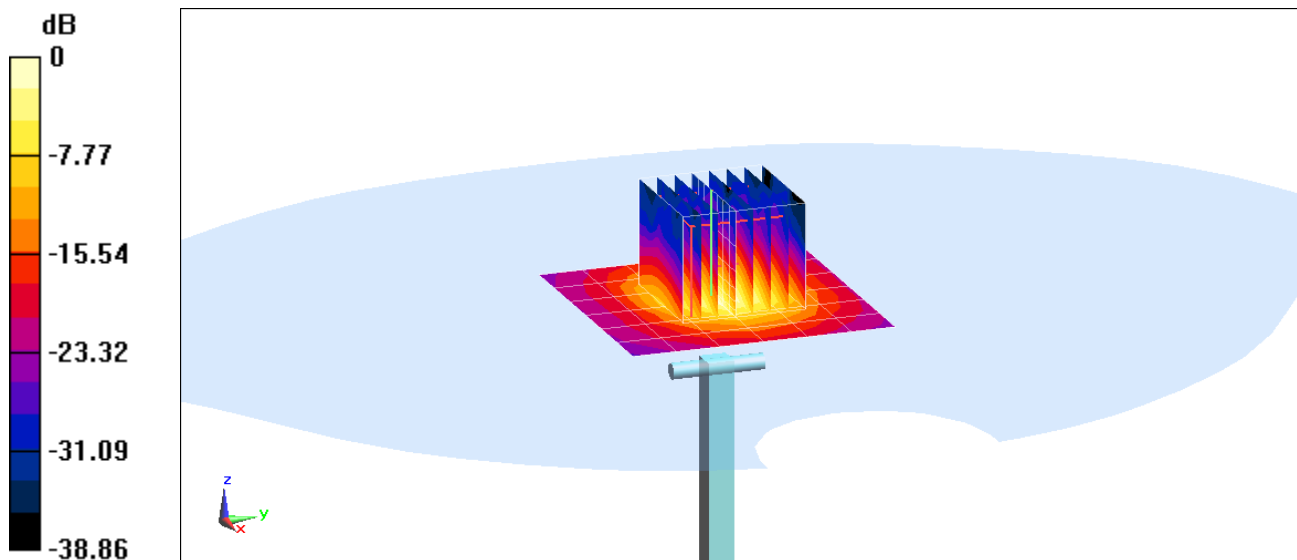

0 dB = 9.27 W/kg = 9.67 dBW/kg

# PCTEST ENGINEERING LABORATORY, INC.

**DUT: Dipole 5 GHz; Type: D5GHzV2; Serial: 1237**

Communication System: UID 0, CW; Frequency: 5600 MHz; Duty Cycle: 1:1

Medium: 5GHz Head Medium parameters used:

$f = 5600 \text{ MHz}$ ;  $\sigma = 5.015 \text{ S/m}$ ;  $\epsilon_r = 34.923$ ;  $\rho = 1000 \text{ kg/m}^3$

Phantom section: Flat Section; Space: 1.0 cm

Test Date: 03-27-2017; Ambient Temp: 22.7°C; Tissue Temp: 21.0°C

Probe: EX3DV4 - SN7308; ConvF(4.63, 4.63, 4.63); Calibrated: 7/21/2016;

Sensor-Surface: 1.4mm (Mechanical Surface Detection)

Electronics: DAE4 Sn859; Calibrated: 5/11/2016

Phantom: SAM Left; Type: QD000P40CC; Serial: TP: 1375

Measurement SW: DASY52, Version 52.8 (8); SEMCAD X Version 14.6.10 (7331)

## 5600 MHz System Verification at 17.0 dBm (50 mW)

**Area Scan (7x7x1):** Measurement grid: dx=10mm, dy=10mm

**Zoom Scan (8x8x7)/Cube 0:** Measurement grid: dx=4mm, dy=4mm, dz=1.4mm; Graded Ratio: 1.4

Peak SAR (extrapolated) = 18.1 W/kg

**SAR(1 g) = 4.09 W/kg**

Deviation(1 g) = -1.80%

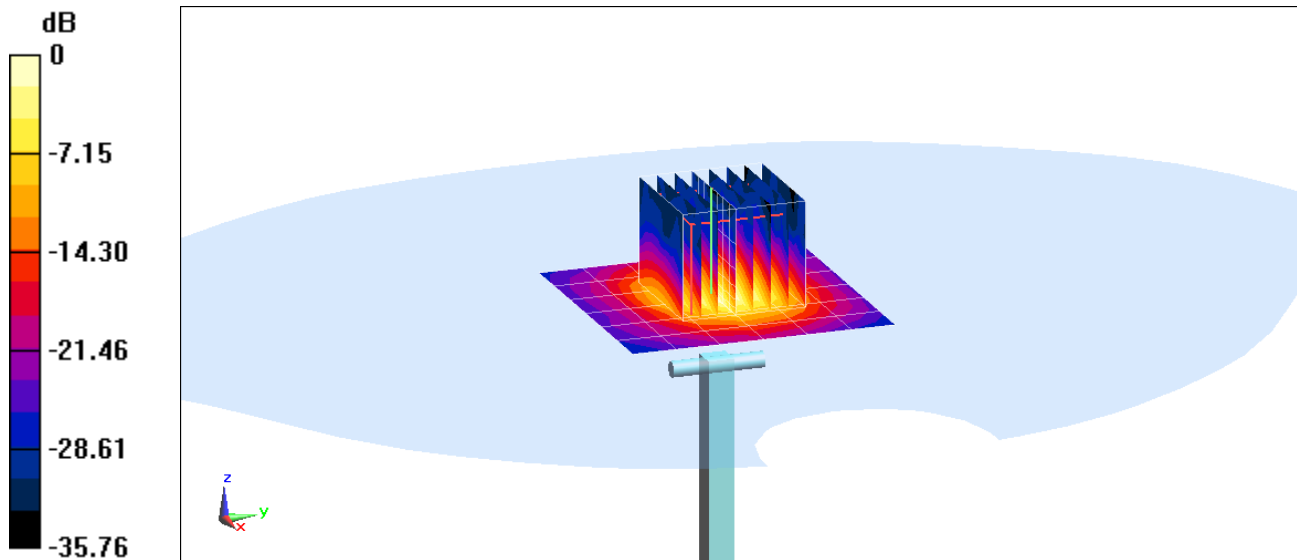

0 dB = 9.97 W/kg = 9.99 dBW/kg

# PCTEST ENGINEERING LABORATORY, INC.

**DUT: Dipole 5 GHz; Type: D5GHzV2; Serial: 1237**

Communication System: UID 0, CW; Frequency: 5750 MHz; Duty Cycle: 1:1

Medium: 5GHz Head Medium parameters used (interpolated):

$f = 5750 \text{ MHz}$ ;  $\sigma = 5.157 \text{ S/m}$ ;  $\epsilon_r = 34.763$ ;  $\rho = 1000 \text{ kg/m}^3$

Phantom section: Flat Section; Space: 1.0 cm

Test Date: 03-27-2017; Ambient Temp: 22.7°C; Tissue Temp: 21.0°C

Probe: EX3DV4 - SN7308; ConvF(4.86, 4.86, 4.86); Calibrated: 7/21/2016;

Sensor-Surface: 1.4mm (Mechanical Surface Detection)

Electronics: DAE4 Sn859; Calibrated: 5/11/2016

Phantom: SAM Left; Type: QD000P40CC; Serial: TP: 1375

Measurement SW: DASY52, Version 52.8 (8); SEMCAD X Version 14.6.10 (7331)

## 5750 MHz System Verification at 17.0 dBm (50 mW)

**Area Scan (7x7x1):** Measurement grid: dx=10mm, dy=10mm

**Zoom Scan (8x9x7)/Cube 0:** Measurement grid: dx=4mm, dy=4mm, dz=1.4mm; Graded Ratio: 1.4

Peak SAR (extrapolated) = 17.0 W/kg

**SAR(1 g) = 3.78 W/kg**

Deviation(1 g) = -7.24%

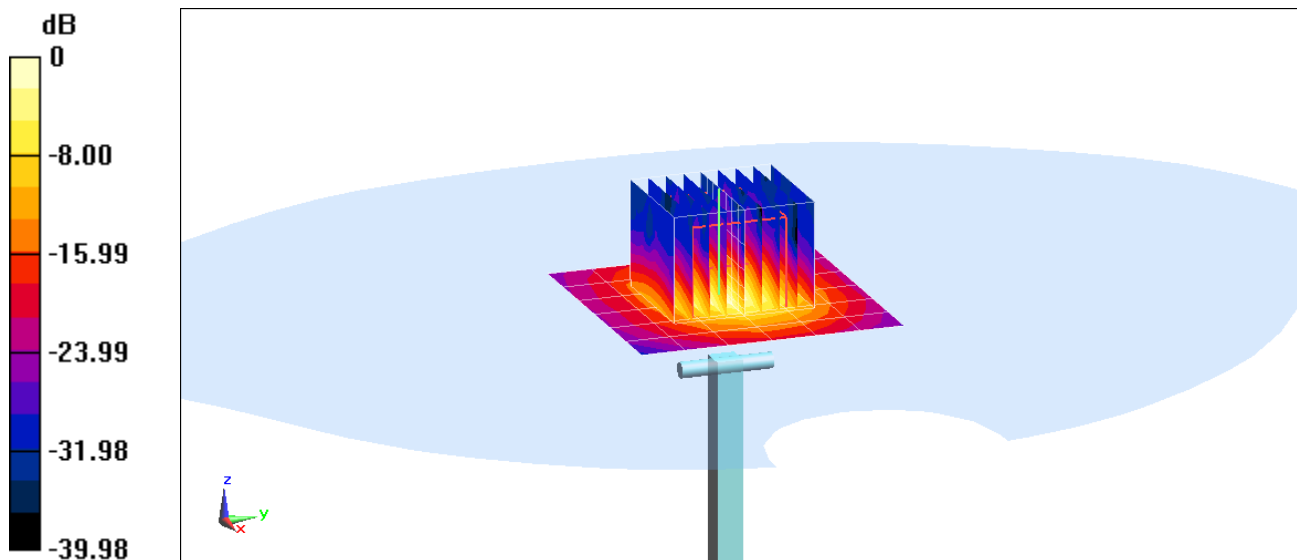

0 dB = 9.51 W/kg = 9.78 dBW/kg

# PCTEST ENGINEERING LABORATORY, INC.

**DUT: Dipole 835 MHz; Type: D835V2; Serial: 4d047**

Communication System: UID 0, CW; Frequency: 835 MHz; Duty Cycle: 1:1

Medium: 835 Body Medium parameters used:

$f = 835 \text{ MHz}$ ;  $\sigma = 0.992 \text{ S/m}$ ;  $\epsilon_r = 54.075$ ;  $\rho = 1000 \text{ kg/m}^3$

Phantom section: Flat Section; Space: 1.5 cm

Test Date: 03-27-2017; Ambient Temp: 21.4°C; Tissue Temp: 21.5°C

Probe: ES3DV3 - SN3318; ConvF(6.37, 6.37, 6.37); Calibrated: 2/10/2017;

Sensor-Surface: 3mm (Mechanical Surface Detection)

Electronics: DAE4 Sn665; Calibrated: 2/9/2017

Phantom: SAM with CRP (Left); Type: SAM; Serial: 1715

Measurement SW: DASY52, Version 52.8 (8); SEMCAD X Version 14.6.10 (7331)

## 835 MHz System Verification at 23.0 dBm (200 mW)

**Area Scan (7x14x1):** Measurement grid: dx=15mm, dy=15mm

**Zoom Scan (5x5x7)/Cube 0:** Measurement grid: dx=8mm, dy=8mm, dz=5mm

Peak SAR (extrapolated) = 2.87 W/kg

**SAR(1 g) = 1.98 W/kg**

Deviation(1 g) = 3.45%

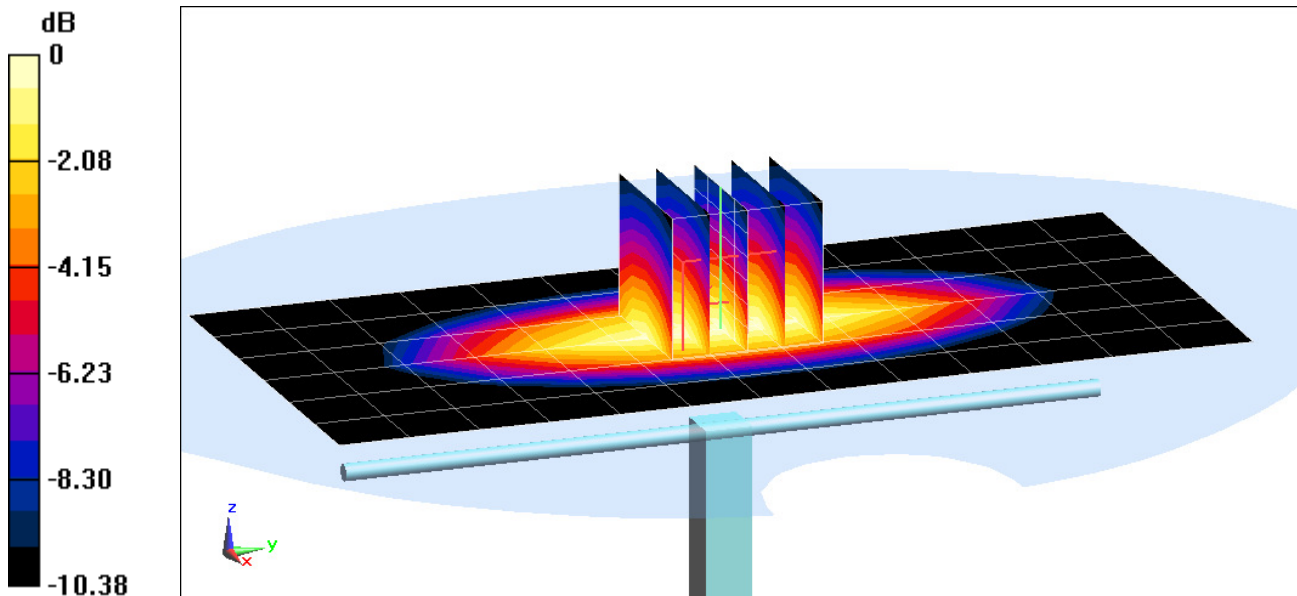

0 dB = 2.32 W/kg = 3.65 dBW/kg

# PCTEST ENGINEERING LABORATORY, INC.

**DUT: Dipole 1750 MHz; Type: D1765V2; Serial: 1008**

Communication System: UID 0, CW; Frequency: 1750 MHz; Duty Cycle: 1:1

Medium: 1750 Body Medium parameters used:

$f = 1750 \text{ MHz}$ ;  $\sigma = 1.474 \text{ S/m}$ ;  $\epsilon_r = 52.407$ ;  $\rho = 1000 \text{ kg/m}^3$

Phantom section: Flat Section; Space: 1.0 cm

Test Date: 04-05-2017; Ambient Temp: 24.0°C; Tissue Temp: 23.0°C

Probe: ES3DV3 - SN3213; ConvF(5.09, 5.09, 5.09); Calibrated: 2/10/2017;

Sensor-Surface: 3mm (Mechanical Surface Detection)

Electronics: DAE4 Sn1272; Calibrated: 2/9/2017

Phantom: SAM Right; Type: SAM; Serial: 1757

Measurement SW: DASY52, Version 52.8 (8); SEMCAD X Version 14.6.10 (7331)

## 1750 MHz System Verification at 20.0 dBm (100 mW)

**Area Scan (7x9x1):** Measurement grid: dx=15mm, dy=15mm

**Zoom Scan (5x5x7)/Cube 0:** Measurement grid: dx=8mm, dy=8mm, dz=5mm

Peak SAR (extrapolated) = 6.64 W/kg

**SAR(1 g) = 3.75 W/kg**

Deviation(1 g) = 0.54%

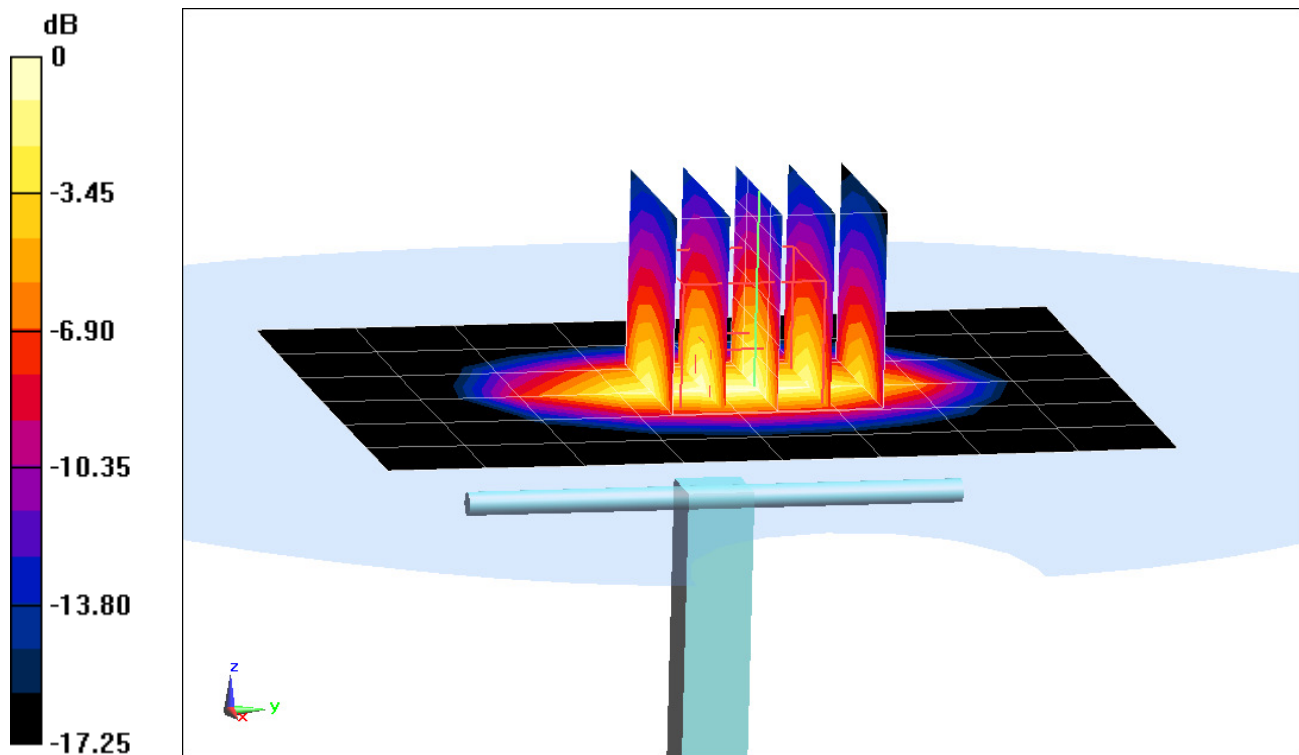

0 dB = 4.69 W/kg = 6.71 dBW/kg

# PCTEST ENGINEERING LABORATORY, INC.

**DUT: Dipole 1900 MHz; Type: D1900V2; Serial: 5d080**

Communication System: UID 0, CW; Frequency: 1900 MHz; Duty Cycle: 1:1

Medium: 1900 Body Medium parameters used (interpolated):

$f = 1900 \text{ MHz}$ ;  $\sigma = 1.573 \text{ S/m}$ ;  $\epsilon_r = 52.326$ ;  $\rho = 1000 \text{ kg/m}^3$

Phantom section: Flat Section; Space: 1.0 cm

Test Date: 03-27-2017; Ambient Temp: 21.8°C; Tissue Temp: 22.3°C

Probe: ES3DV3 - SN3287; ConvF(4.94, 4.94, 4.94); Calibrated: 9/19/2016;

Sensor-Surface: 3mm (Mechanical Surface Detection)

Electronics: DAE4 Sn1408; Calibrated: 9/14/2016

Phantom: SAM Front; Type: SAM; Serial: 1686

Measurement SW: DASY52, Version 52.8 (8); SEMCAD X Version 14.6.10 (7331)

## 1900 MHz System Verification at 20.0 dBm (100 mW)

**Area Scan (7x10x1):** Measurement grid: dx=15mm, dy=15mm

**Zoom Scan (5x5x7)/Cube 0:** Measurement grid: dx=8mm, dy=8mm, dz=5mm

Peak SAR (extrapolated) = 7.50 W/kg

**SAR(1 g) = 4.17 W/kg**

Deviation(1 g) = 6.65%

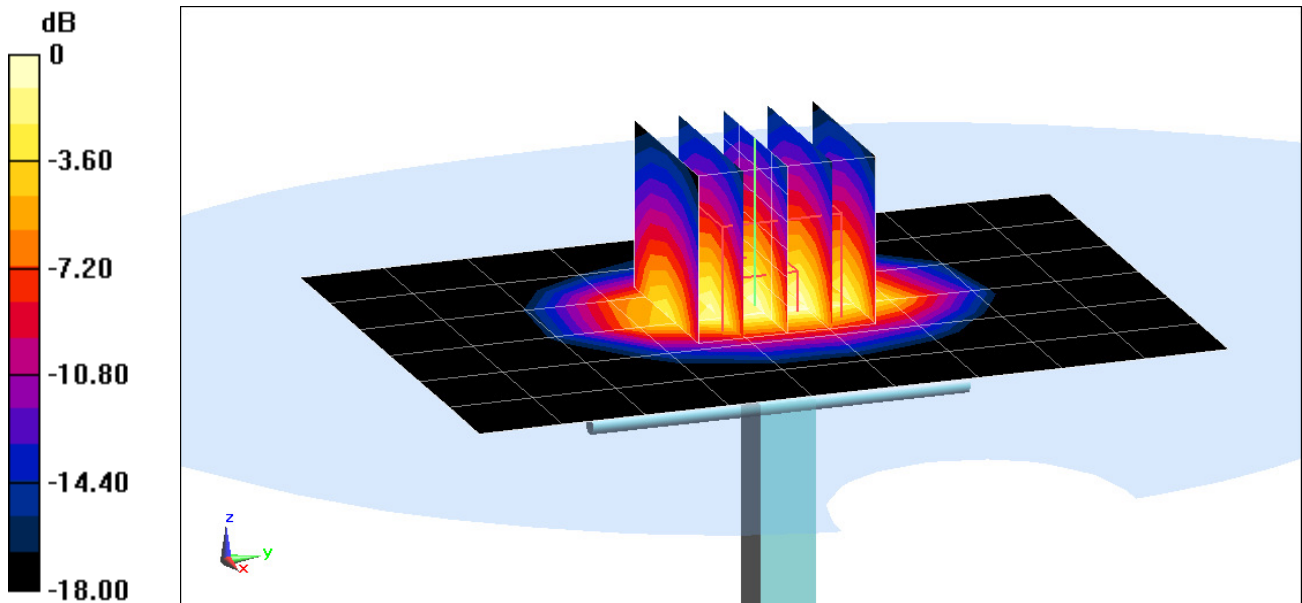

0 dB = 5.29 W/kg = 7.23 dBW/kg

# PCTEST ENGINEERING LABORATORY, INC.

**DUT: Dipole 2450 MHz; Type: D2450V2; Serial: 981**

Communication System: UID 0, CW; Frequency: 2450 MHz; Duty Cycle: 1:1

Medium: 2450 Body Medium parameters used:

$f = 2450$  MHz;  $\sigma = 2.007$  S/m;  $\epsilon_r = 51.801$ ;  $\rho = 1000$  kg/m<sup>3</sup>

Phantom section: Flat Section; Space: 1.0 cm

Test Date: 03-23-2017; Ambient Temp: 22.3°C; Tissue Temp: 22.0°C

Probe: EX3DV4 - SN7406; ConvF(7.24, 7.24, 7.24); Calibrated: 04/19/2016;

Sensor-Surface: 1.4mm (Mechanical Surface Detection)

Electronics: DAE4 Sn1407; Calibrated: 04/14/2016

Phantom: SAM 5.0 front; Type: QD000P40CD; Serial: TP:-1648

Measurement SW: DASY52, Version 52.8 (8); SEMCAD X Version 14.6.10 (7331)

## 2450 MHz System Verification at 20.0 dBm (100 mW)

**Area Scan (8x9x1):** Measurement grid: dx=12mm, dy=12mm

**Zoom Scan (7x7x7)/Cube 0:** Measurement grid: dx=5mm, dy=5mm, dz=5mm

Peak SAR (extrapolated) = 10.2 W/kg

**SAR(1 g) = 4.98 W/kg**

Deviation(1 g) = -1.97%

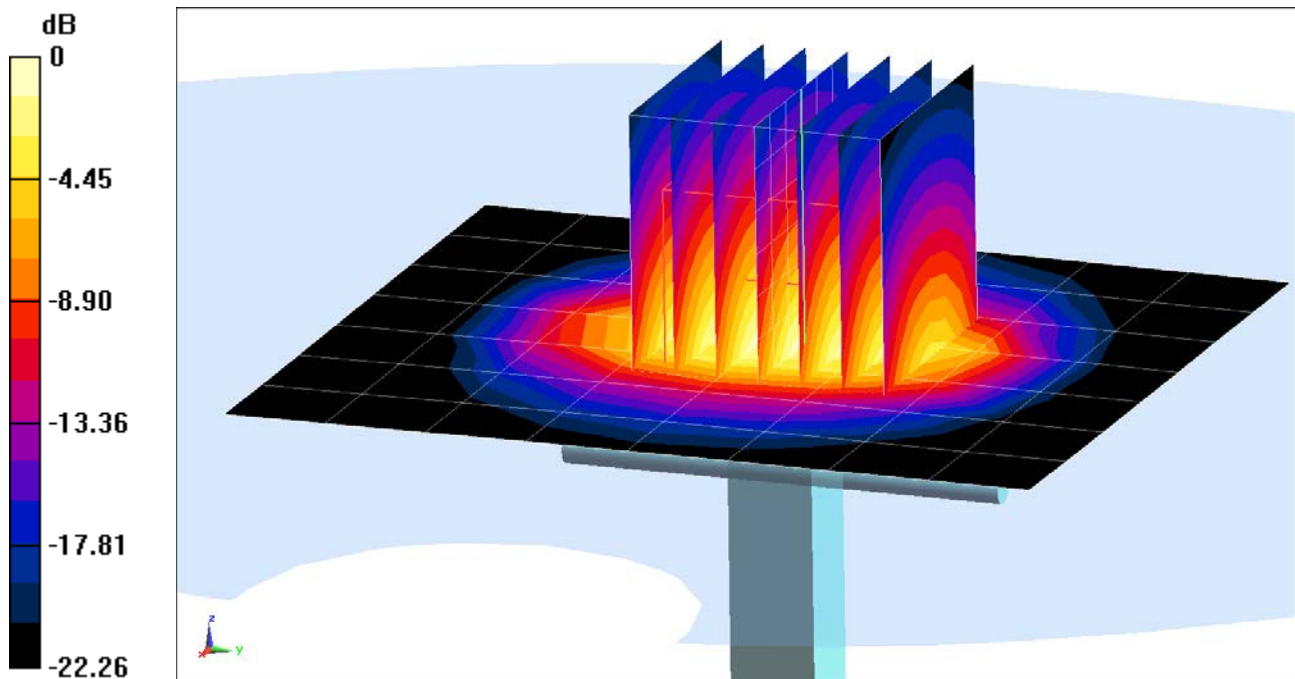

0 dB = 8.21 W/kg = 9.14 dBW/kg

# PCTEST ENGINEERING LABORATORY, INC.

**DUT: Dipole 2450 MHz; Type: D2450V2; Serial: 981**

Communication System: UID 0, CW; Frequency: 2450 MHz; Duty Cycle: 1:1

Medium: 2450 Body Medium parameters used:

$f = 2450$  MHz;  $\sigma = 2.011$  S/m;  $\epsilon_r = 50.977$ ;  $\rho = 1000$  kg/m<sup>3</sup>

Phantom section: Flat Section; Space: 1.0 cm

Test Date: 03-29-2017; Ambient Temp: 23.5°C; Tissue Temp: 22.1°C

Probe: EX3DV4 - SN7406; ConvF(7.24, 7.24, 7.24); Calibrated: 04/19/2016;

Sensor-Surface: 1.4mm (Mechanical Surface Detection)

Electronics: DAE4 Sn1407; Calibrated: 04/14/2016

Phantom: SAM 5.0 front; Type: QD000P40CD; Serial: TP:-1648

Measurement SW: DASY52, Version 52.8 (8); SEMCAD X Version 14.6.10 (7331)

## 2450 MHz System Verification at 20.0 dBm (100 mW)

**Area Scan (8x9x1):** Measurement grid: dx=12mm, dy=12mm

**Zoom Scan (7x7x7)/Cube 0:** Measurement grid: dx=5mm, dy=5mm, dz=5mm

Peak SAR (extrapolated) = 9.77 W/kg

**SAR(1 g) = 4.77 W/kg**

Deviation(1 g) = -6.10%

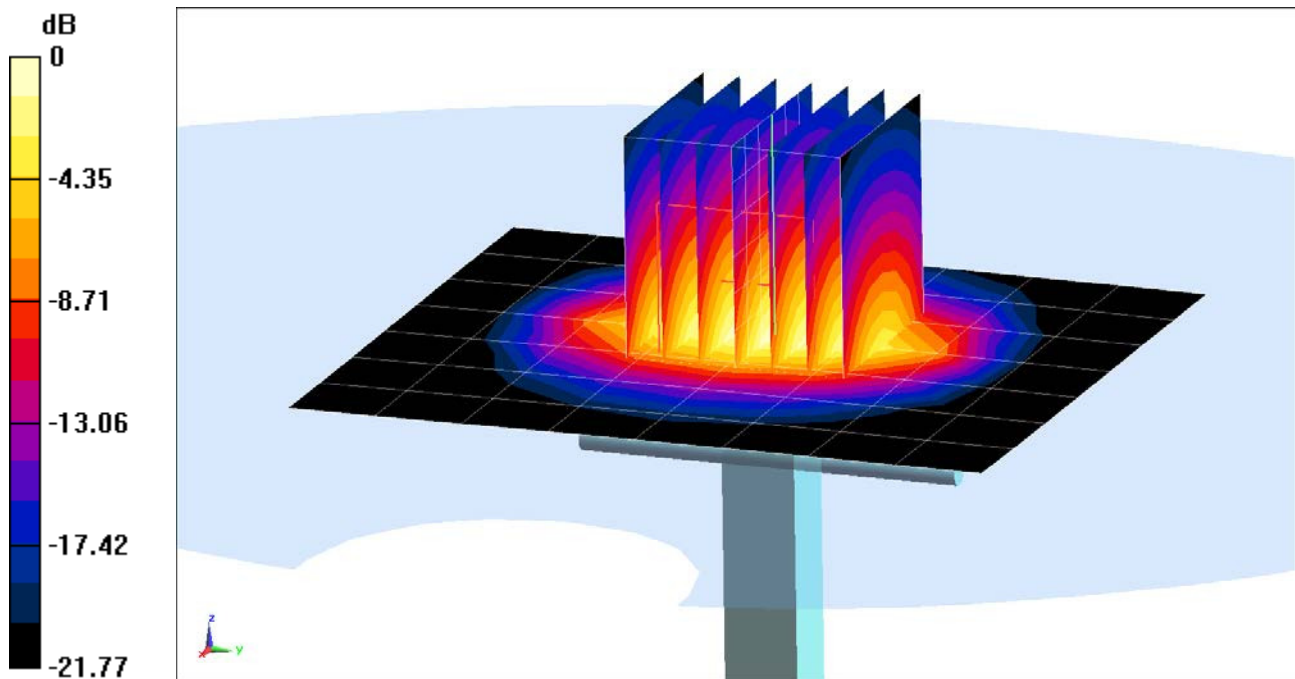

0 dB = 7.95 W/kg = 9.00 dBW/kg

# PCTEST ENGINEERING LABORATORY, INC.

**DUT: Dipole 5 GHz; Type: D5GHzV2; Serial: 1237**

Communication System: UID 0, CW; Frequency: 5250 MHz; Duty Cycle: 1:1  
Medium: 5GHz Body Medium parameters used (interpolated):  
 $f = 5250 \text{ MHz}$ ;  $\sigma = 5.524 \text{ S/m}$ ;  $\epsilon_r = 47.038$ ;  $\rho = 1000 \text{ kg/m}^3$   
Phantom section: Flat Section; Space: 1.0 cm

Test Date: 03-20-2017; Ambient Temp: 23.1°C; Tissue Temp: 21.0°C

Probe: EX3DV4 - SN7308; ConvF(4.45, 4.45, 4.45); Calibrated: 7/21/2016;  
Sensor-Surface: 1.4mm (Mechanical Surface Detection)  
Electronics: DAE4 Sn859; Calibrated: 5/11/2016  
Phantom: SAM Left; Type: QD000P40CC; Serial: TP: 1375  
Measurement SW: DASY52, Version 52.8 (8); SEMCAD X Version 14.6.10 (7331)

## 5250 MHz System Verification at 17.0 dBm (50 mW)

**Area Scan (7x7x1):** Measurement grid: dx=10mm, dy=10mm

**Zoom Scan (8x8x7)/Cube 0:** Measurement grid: dx=4mm, dy=4mm, dz=1.4mm; Graded Ratio: 1.4

Peak SAR (extrapolated) = 15.1 W/kg

**SAR(1 g) = 3.68 W/kg**

Deviation(1 g) = -1.60%

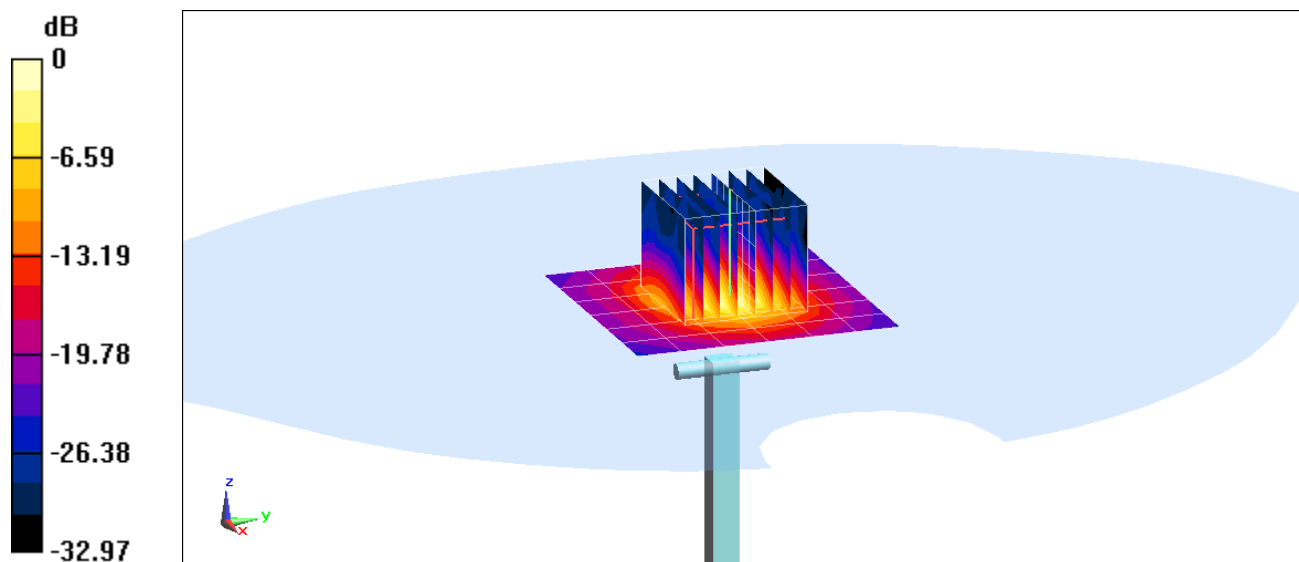

0 dB = 8.99 W/kg = 9.54 dBW/kg

# PCTEST ENGINEERING LABORATORY, INC.

**DUT: Dipole 5 GHz; Type: D5GHzV2; Serial: 1237**

Communication System: UID 0, CW; Frequency: 5600 MHz; Duty Cycle: 1:1

Medium: 5GHz Body Medium parameters used:

$f = 5600 \text{ MHz}$ ;  $\sigma = 6.009 \text{ S/m}$ ;  $\epsilon_r = 46.52$ ;  $\rho = 1000 \text{ kg/m}^3$

Phantom section: Flat Section; Space: 1.0 cm

Test Date: 03-20-2017; Ambient Temp: 23.1°C; Tissue Temp: 21.0°C

Probe: EX3DV4 - SN7308; ConvF(3.75, 3.75, 3.75); Calibrated: 7/21/2016;

Sensor-Surface: 1.4mm (Mechanical Surface Detection)

Electronics: DAE4 Sn859; Calibrated: 5/11/2016

Phantom: SAM Left; Type: QD000P40CC; Serial: TP: 1375

Measurement SW: DASY52, Version 52.8 (8); SEMCAD X Version 14.6.10 (7331)

## 5600 MHz System Verification at 17.0 dBm (50 mW)

**Area Scan (7x7x1):** Measurement grid: dx=10mm, dy=10mm

**Zoom Scan (8x8x7)/Cube 0:** Measurement grid: dx=4mm, dy=4mm, dz=1.4mm; Graded Ratio: 1.4

Peak SAR (extrapolated) = 16.8 W/kg

**SAR(1 g) = 4.06 W/kg**

Deviation(1 g) = 5.45%

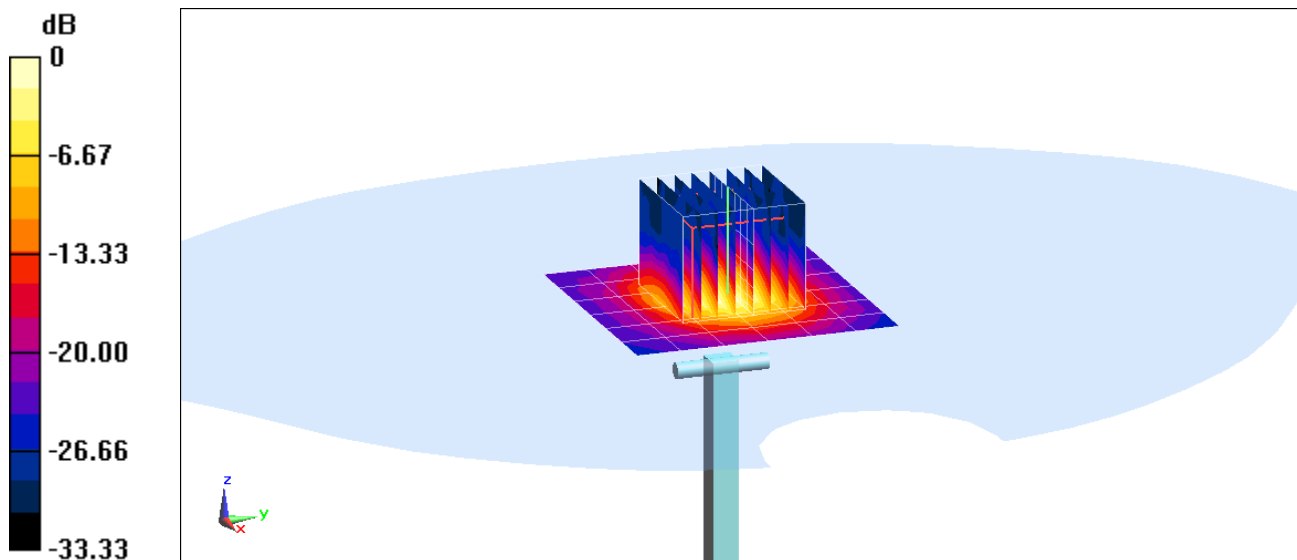

0 dB = 9.61 W/kg = 9.83 dBW/kg

# PCTEST ENGINEERING LABORATORY, INC.

**DUT: Dipole 5 GHz; Type: D5GHzV2; Serial: 1237**

Communication System: UID 0, CW; Frequency: 5750 MHz; Duty Cycle: 1:1  
Medium: 5GHz Body Medium parameters used (interpolated):  
 $f = 5750 \text{ MHz}$ ;  $\sigma = 6.203 \text{ S/m}$ ;  $\epsilon_r = 46.288$ ;  $\rho = 1000 \text{ kg/m}^3$   
Phantom section: Flat Section; Space: 1.0 cm

Test Date: 03-20-2017; Ambient Temp: 23.1°C; Tissue Temp: 21.0°C

Probe: EX3DV4 - SN7308; ConvF(4.04, 4.04, 4.04); Calibrated: 7/21/2016;  
Sensor-Surface: 1.4mm (Mechanical Surface Detection)  
Electronics: DAE4 Sn859; Calibrated: 5/11/2016  
Phantom: SAM Left; Type: QD000P40CC; Serial: TP: 1375  
Measurement SW: DASY52, Version 52.8 (8); SEMCAD X Version 14.6.10 (7331)

## 5750 MHz System Verification at 17.0 dBm (50 mW)

**Area Scan (7x7x1):** Measurement grid: dx=10mm, dy=10mm

**Zoom Scan (8x8x7)/Cube 0:** Measurement grid: dx=4mm, dy=4mm, dz=1.4mm; Graded Ratio: 1.4

Peak SAR (extrapolated) = 15.3 W/kg

**SAR(1 g) = 3.53 W/kg**

Deviation(1 g) = -6.37%

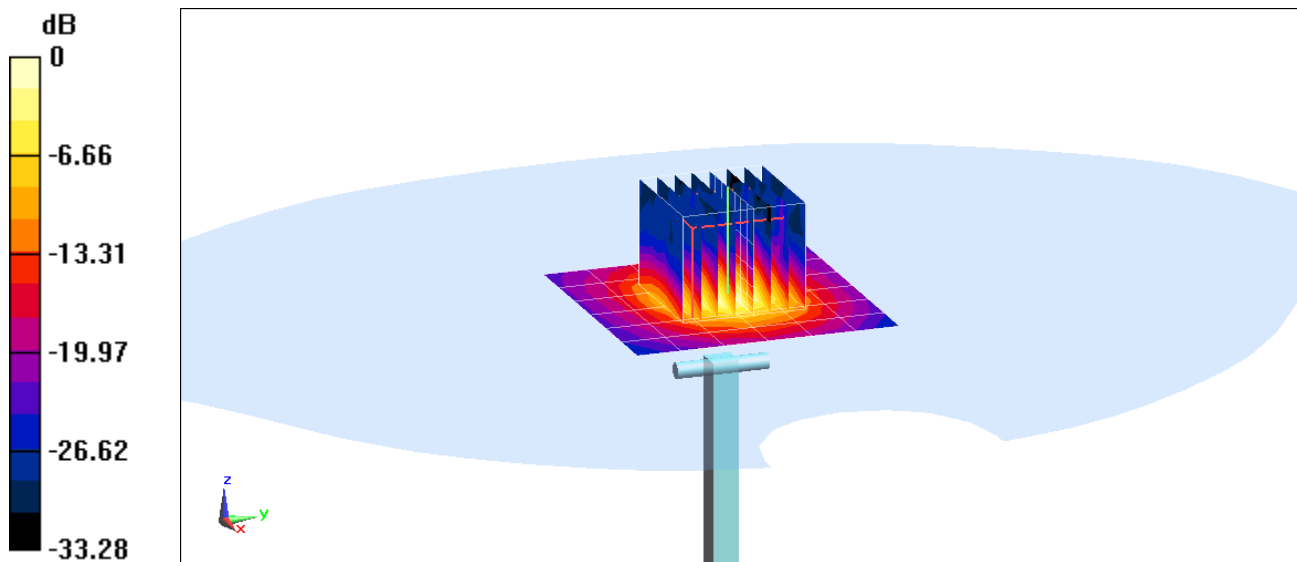

0 dB = 8.68 W/kg = 9.39 dBW/kg

# PCTEST ENGINEERING LABORATORY, INC.

**DUT: Dipole 5 GHz; Type: D5GHzV2; Serial: 1237**

Communication System: UID 0, CW; Frequency: 5750 MHz; Duty Cycle: 1:1

Medium: 5 GHz Body Medium parameters used (interpolated):

$f = 5750 \text{ MHz}$ ;  $\sigma = 6.149 \text{ S/m}$ ;  $\epsilon_r = 46.553$ ;  $\rho = 1000 \text{ kg/m}^3$

Phantom section: Flat Section; Space: 1.0 cm

Test Date: 03-28-2017; Ambient Temp: 23.5°C; Tissue Temp: 22.3°C

Probe: EX3DV4 - SN3589; ConvF(3.83, 3.83, 3.83); Calibrated: 1/13/2017;

Sensor-Surface: 1.4mm (Mechanical Surface Detection)

Electronics: DAE4 Sn1466; Calibrated: 1/16/2017

Phantom: SAM with CRP v5.0 Front; Type: QD000P40CD; Serial: 1646

Measurement SW: DASY52, Version 52.8 (8); SEMCAD X Version 14.6.10 (7331)

## 5750 MHz System Verification at 17.0 dBm (50 mW)

**Area Scan (7x7x1):** Measurement grid: dx=10mm, dy=10mm

**Zoom Scan (8x8x7)/Cube 0:** Measurement grid: dx=4mm, dy=4mm, dz=1.4mm; Graded Ratio: 1.4

Peak SAR (extrapolated) = 16.5 W/kg

**SAR(1 g) = 3.55 W/kg**

Deviation(1 g) = -5.84%

