



**FCC CFR47 PART 22 SUBPART H
FCC CFR47 PART 24 SUBPART E**

WWAN

C2PC CERTIFICATION TEST REPORT

FOR

GSM/WCDMA Phone + BT/BLE, DTS b/g/n

MODEL NUMBER : SM-J105B, SM-J105B/DL, SM-J105B/DS, SM-J106B, SM-J106B/DS

FCC ID: A3LSMJ105B

REPORT NUMBER: 15K23807-E4V2

ISSUE DATE: SEP 12, 2016

Prepared for
**SAMSUNG ELECTRONICS CO., LTD.
129 SAMSUNG-RO, YEONGTONG-GU, SUWON-SI,
GYEONGGI-DO, 16677, KOREA**

Prepared by
**UL Korea, Ltd. Suwon Laboratory
218 Maeyeong-ro, Yeongtong-gu,
Suwon-si, Gyeonggi-do, 16675, Korea
TEL: (031) 337-9902
FAX: (031) 213-5433**



Revision History

<u>Rev.</u>	<u>Issue Date</u>	<u>Revisions</u>	<u>Revised By</u>
V1	09/09/16	Initial issue	SungGil Park
V2	09/12/16	Revised section 5.1, 5.2, 5.3, 7, 8.2.1	SungGil Park

TABLE OF CONTENTS

1. ATTESTATION OF TEST RESULTS	4
2. TEST METHODOLOGY	5
3. FACILITIES AND ACCREDITATION	5
4. CALIBRATION AND UNCERTAINTY	5
4.1. <i>MEASURING INSTRUMENT CALIBRATION</i>	5
4.2. <i>SAMPLE CALCULATION</i>	5
4.3. <i>MEASUREMENT UNCERTAINTY</i>	5
5. EQUIPMENT UNDER TEST	6
5.1. <i>DESCRIPTION OF EUT</i>	6
5.2. <i>MAXIMUM OUTPUT POWER</i>	6
5.3. <i>DESCRIPTION OF AVAILABLE ANTENNAS</i>	6
5.4. <i>DESCRIPTION OF TEST SETUP</i>	7
6. TEST AND MEASUREMENT EQUIPMENT	9
7. Summary Table	10
8. RADIATED TEST RESULTS	11
8.1. <i>RADIATED POWER (ERP & EIRP)</i>	11
8.1.1. ERP/EIRP Results.....	12
8.1.2. ERP/EIRP DATA	13
8.2. <i>FIELD STRENGTH OF SPURIOUS RADIATION</i>	17
8.2.1. SPURIOUS RADIATION TEST RESULT	18
9. SETUP PHOTOS	23

1. ATTESTATION OF TEST RESULTS

COMPANY NAME: SAMSUNG ELECTRONICS CO., LTD.
EUT DESCRIPTION: GSM/WCDMA Phone + BT/BLE, DTS b/g/n
MODEL NUMBER: SM-J105B, SM-J105B/DL, SM-J105B/DS, SM-J106B, SM-J106B/DS
SERIAL NUMBER: R31H8002A5A (RADIATED); R31H8002A8W (CONDUCTED)
DATE TESTED: AUG 23, 2016 - SEP 09, 2016

APPLICABLE STANDARDS	
STANDARD	TEST RESULTS
FCC PART 22H and 24E	Pass

UL Korea, Ltd. tested the above equipment in accordance with the requirements set forth in the above standards. All indications of Pass/Fail in this report are opinions expressed by UL Korea, Ltd. based on interpretations and/or observations of test results. Measurement Uncertainties were not taken into account and are published for informational purposes only. The test results show that the equipment tested is capable of demonstrating compliance with the requirements as documented in this report.

Note: The results documented in this report apply only to the tested sample, under the conditions and modes of operation as described herein. This document may not be altered or revised in any way unless done so by UL Korea, Ltd. and all revisions are duly noted in the revisions section. Any alteration of this document not carried out by UL Korea, Ltd. will constitute fraud and shall nullify the document. This report must not be used by the client to claim product certification, approval, or endorsement by IAS, any agency of the Federal Government, or any agency of any government.

Approved & Released For
UL Korea, Ltd. By:

Tested By:



CY Choi
Suwon Lab Engineer
UL Korea, Ltd.

SungGil Park
Suwon Lab Engineer
UL Korea, Ltd.

2. TEST METHODOLOGY

The tests documented in this report were performed in accordance with TIA-603-D, FCC CFR 47 Part 2, FCC CFR 47 Part 22, FCC CFR Part 24 and FCC CFR Part 27.

3. FACILITIES AND ACCREDITATION

The test sites and measurement facilities used to collect data are located at 218 Maeyeong-ro, Yeongtong-gu, Suwon-si, Gyeonggi-do, 16675, Korea. Line conducted emissions are measured only at the 218 address. The following table identifies which facilities were utilized for radiated emission measurements documented in this report. Specific facilities are also identified in the test results sections.

218 Maeyeong-ro	
<input type="checkbox"/>	Chamber 1
<input checked="" type="checkbox"/>	Chamber 2

UL Korea, Ltd. is accredited by IAS, Laboratory Code TL-637. The full scope of accreditation can be viewed at <http://www.iasonline.org/PDF/TL/TL-637.pdf>.

4. CALIBRATION AND UNCERTAINTY

4.1. MEASURING INSTRUMENT CALIBRATION

The measuring equipment utilized to perform the tests documented in this report has been calibrated in accordance with the manufacturer's recommendations, and is traceable to recognized national standards.

4.2. SAMPLE CALCULATION

Where relevant, the following sample calculation is provided:

EIRP = PSA reading with EUT worst orientation (dBm) + Path loss (dB) – cable loss(between the SG and substitution antenna) + Substitution Antenna Factor (dBi)

ERP = PSA reading with EUT worst orientation (dBm) + Path loss (dB) – cable loss(between the SG and substitution antenna)

(Path loss = Signal generator output – PSA reading with substitution antenna)

4.3. MEASUREMENT UNCERTAINTY

Where relevant, the following measurement uncertainty levels have been estimated for tests performed on the apparatus:

PARAMETER	UNCERTAINTY
Conducted Disturbance, 0.15 to 30 MHz	2.32 dB
Radiated Disturbance, Below 1GHz	4.14 dB
Radiated Disturbance, Above 1 GHz	5.97 dB

Uncertainty figures are valid to a confidence level of 95%.

5. EQUIPMENT UNDER TEST

5.1. DESCRIPTION OF EUT

This EUT is GSM/WCDMA Phone + BT/BLE, DTS b/g/n.

SM-J105B, SM-J105B/DL and SM-J105B/DS are same hardware, but for different number of SIM card slot. SM-J105B has one slot. SM-J105B/DL and SM-J105B/DS are dual SIM version. SM-J106B and SM-J106B/DS are same hardware, but different number of SIM card slot. SM-J106B has one slot. SM-J106B/DS is dual SIM version. SM-J106B/DS was used for this C2PC test.

5.2. MAXIMUM OUTPUT POWER

Please refer to WWAN test report(FCM-048-L1-1, FCM-048-L2-1-2) of FCC ID: A3LSMJ105B

5.3. DESCRIPTION OF AVAILABLE ANTENNAS

The radio utilizes a FPCB antenna for the [List the bands supported] with a maximum peak gain as follow:

Frequency (MHz)	Peak Gain (dBi)
WCDMA Band 5 / LTE Band 5 824 ~ 849 MHz	-1.7
WCDMA Band 2 / LTE Band 2 1850 ~ 1910 MHz	2.8

5.4. DESCRIPTION OF TEST SETUP

SUPPORT EQUIPMENT

Support Equipment List				
Description	Manufacturer	Model	Serial Number	FCC ID
Adapter	SAMSUNG	ETA0U60JBE	DK1G826HS17-E	N/A
Data Cable	SAMSUNG	ECB-DU2EBE	N/A	N/A
Wireless Charger	SAMSUNG	EP-YO760	N/A	A3LEPYO760

I/O CABLES

I/O Cable List						
Cable No	Port	# of identical ports	Connector Type	Cable Type	Cable Length (m)	Remarks
1	DC Power	1	Mini-USB	Shielded	0.8m	N/A

TEST SETUP

The EUT is continuously communicated to the call box during the tests.

SETUP DIAGRAM FOR TESTS (CONDUCTED TEST SETUP)

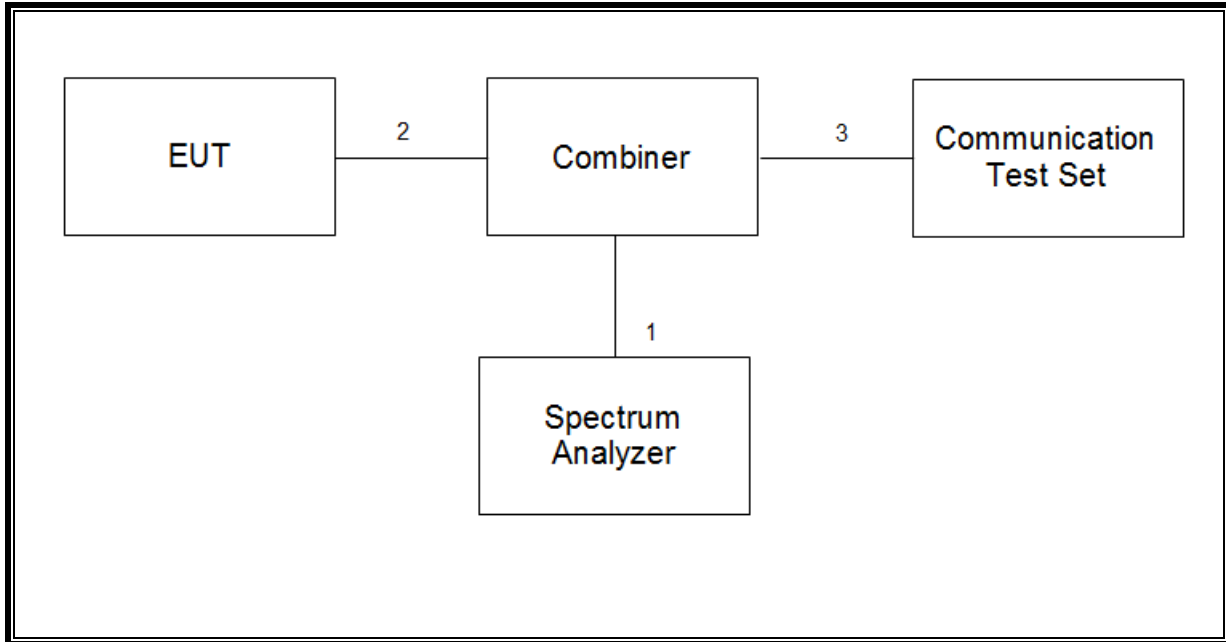

SETUP DIAGRAM FOR TESTS (RADIATED TEST SETUP)

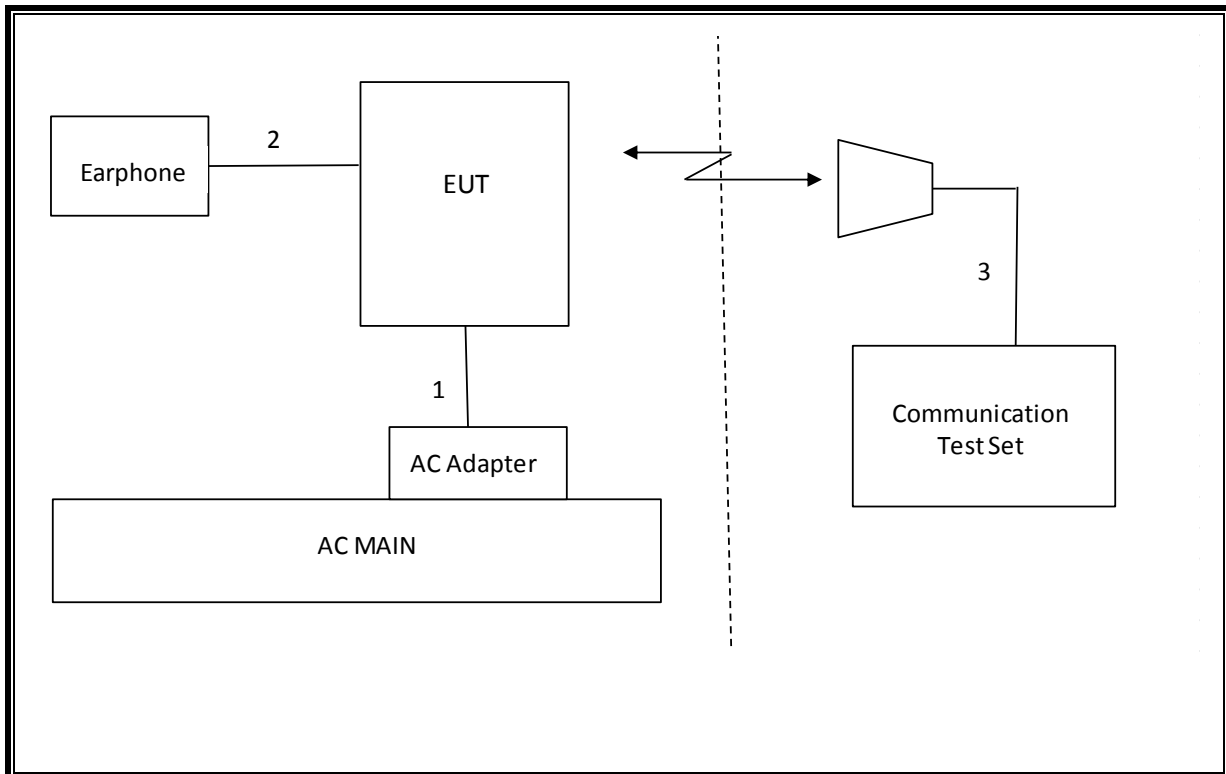

6. TEST AND MEASUREMENT EQUIPMENT

The following test and measurement equipment was utilized for the tests documented in this report:

Test Equipment List				
Description	Manufacturer	Model	S/N	Cal Due
Antenna, Tuned Dipole 400~1000 MHz	ETS	3121D DB4	00164753	07-28-17
Antenna, Horn, 40 GHz	ETS	3116C	00166155	11-30-17
Antenna, Horn, 40 GHz	ETS	3116C-PA	00168841	12-15-17
Antenna, Bilog, 30MHz-1GHz	SCHWARZBECK	VULB9163	750	11-17-16
Antenna, Bilog, 30MHz-1GHz	SCHWARZBECK	VULB9163	749	04-25-17
Antenna, Horn, 18 GHz	ETS	3115	00167211	09-20-16
Antenna, Horn, 18 GHz	ETS	3115	00161451	05-17-17
Antenna, Horn, 18 GHz	ETS	3117	00168724	06-17-17
Antenna, Horn, 18 GHz	ETS	3117	00168717	06-17-17
Combiner	WEINSCHTEL	1575	2152	08-16-17
Communications Test Set	R&S	CMW500	150312	08-17-17
Communications Test Set	R&S	CMW500	115331	08-17-17
DC Power Supply	Agilent / HP	E3640A	MY54226395	08-16-17
Preamplifier, 1000 MHz	Sonoma	310N	341282	08-17-17
Preamplifier, 1000 MHz	Sonoma	310N	351741	08-16-17
Preamplifier	ETS	3115-PA	00167475	08-17-17
Preamplifier, 18 GHz	Miteq	AFS42-00101800-25-S-42	1896138	08-16-17
Spectrum Analyzer, 44 GHz	Agilent / HP	N9030A	MY54170614	08-17-17
Spectrum Analyzer, 44 GHz	Agilent / HP	N9030A	MY54490312	08-16-17
Bluetooth Tester	TESCOM	TC-3000C	3000C000546	08-18-17
Average Power Sensor	R&S	NRZ-Z91	102681	08-16-17
Average Power Sensor	Agilent / HP	U2000	MY54270007	08-17-17
EMI Test Receive, 40 GHz	R&S	ESU40	100439	08-17-17
EMI Test Receive, 40 GHz	R&S	ESU40	100457	08-16-17
EMI Test Receive, 3 GHz	R&S	ESR3	101832	08-16-17
Attenuator / Switch driver	HP	11713A	3748A04272	N/A
High Pass Filter 1.2GHz	Micro-Tronics	HPM50108-02	G005	08-17-17
High Pass Filter 1.2GHz	Micro-Tronics	HPM50108-02	G006	08-17-17
High Pass Filter 2.8GHz	Micro-Tronics	HPM50111-02	010	08-17-17
High Pass Filter 2.8GHz	Micro-Tronics	HPM50111-02	011	08-17-17
High Pass Filter 4GHz	Micro-Tronics	HPM50118-02	G001	08-17-17
High Pass Filter 4GHz	Micro-Tronics	HPM50118-02	G002	08-17-17
LISN	R&S	ENV-216	101836	08-16-17
LISN	R&S	ENV-216	101837	08-16-17
Attenuator	PASTERNAK	PE7087-10	A009	08-16-17

7. Summary Table

C2PC Reason: Please see SM-J106B C2PC description for details.

: The only changes of this C2PC model are memory capacity and flash LED (minor circuitry for non-transmitter portions), so we tested only radiated items.

FCC Part Section	Test Description	Test Limit	Test Condition	Test Result
2.1049	Occupied Band width (99%)	N/A	Conducted	See Original
22.917(a) 24.238(a)	Band Edge / Conducted Spurious Emission	-13dBm		See Original
2.1046	Conducted output power	N/A		See Original
22.355 24.235 27.54	Frequency Stability	2.5PPM		See Original
22.913(a)(2)	Effective Radiated Power	38 dBm	Radiated	Pass
24.232(c)	Equivalent Isotropic Radiated Power	33dBm		Pass
22.917(a) 24.238(a)	Radiated Spurious Emission	-13dBm		Pass

FCC Rule Part	Frequency Range [MHz]	Output Power [W]	Frequency Tolerance	Emission Designator	Emission Bandwidth [MHz]	Communication Type
GSM						
22H	824.2 - 848.8	0.445	2.5 ppm	248KGXW		GSM850
24E	1850.2 - 1909.8	1.371	2.5 ppm	247KGXW		GSM1900
WCDMA						
22H	826.4 - 846.6	0.070	2.5 ppm	4M11F9W		WCDMA B5
24E	1852.4 - 1907.6	0.242	2.5 ppm	4M13F9W		WCDMA B2

8. RADIATED TEST RESULTS

8.1. RADIATED POWER (ERP & EIRP)

RULE PART(S)

FCC: §2.1046, §22.913 and §24.232

LIMITS

22.913(a) - The ERP of mobile transmitters and auxiliary test transmitters must not exceed 7 Watts.

24.232(c) - Mobile/portable stations are limited to 2 watts e.i.r.p. peak power and the equipment must employ means to limit the power to the minimum necessary for successful communications.

In addition, when the transmitter power is measured in terms of average value, the peak-to-average ratio of the power shall not exceed 13dB.

TEST PROCEDURE

ANSI / TIA / EIA 603D Clause 2.2.17; MXA setting reference to 971168 D01 v02r02

For peak power measurement with a MXA:

a) Set the RBW \geq OBW; b) Set VBW $\geq 3 \times$ RBW; c) Set span $\geq 2 \times$ RBW; d) Sweep time = auto couple; e) Detector = peak; f) Ensure that the number of measurement points \geq span/RBW; g) Trace mode = max hold;

For average power measurement with a MXA:

a) Set span to at least 1.5 times the OBW; b) Set RBW = 1-5% of the OBW, not to exceed 1 MHz; c) Set VBW $\geq 3 \times$ RBW; d) Set number of points in sweep $\geq 2 \times$ span / RBW; e) Sweep time = auto-couple; f) Detector = RMS (power averaging); g) Use free run trigger If burst duty cycle ≥ 98 ; h) Use trigger to capture bursts If burst duty cycle < 98 ; i) Trace average at least 100 traces in power averaging (*i.e.*, RMS) mode. j) Compute the power by integrating the spectrum across the OBW of the signal using the instrument's band power measurement function.

TEST RESULTS

8.1.1. ERP/EIRP Results

GSM

Band	Mode	Channel	f [MHz]	ERP / EIRP	
				[dBm]	[mW]
GSM850	GPRS	128	824.2	26.48	444.63
		190	836.6	26.05	402.72
		251	848.8	26.36	432.51
GSM1900	GPRS	512	1850.2	30.91	1233.10
		661	1880.0	31.08	1282.33
		810	1909.8	31.37	1370.88

WCDMA

Band	Mode	Channel	f [MHz]	ERP / EIRP	
				[dBm]	[mW]
Band 5	REL99	4132	826.4	16.79	47.75
		4183	836.6	16.42	43.85
		4233	846.6	18.42	69.50
	HSDPA	4132	826.4	17.20	52.48
		4183	836.6	15.49	35.40
		4233	846.6	18.40	69.18
Band 2	REL99	9262	1852.4	22.50	177.83
		9400	1880.0	22.88	194.09
		9538	1907.6	22.40	173.78
	HSDPA	9262	1852.4	23.84	242.10
		9400	1880.0	23.34	215.77
		9538	1907.6	23.80	239.88

8.1.2. ERP/EIRP DATA

GSM 850

High Frequency Substitution Measurement UL Korea, Ltd. Suwon Laboratory Chamber 2								
Company:		Samsung						
Project #:		16K23807						
Date:		02-16-09						
Test Engineer:		YH Lim						
Configuration:		EUT ONLY, X Position						
Mode:		GPRS 850 MHz						
Test Equipment:								
Receiving: VULB9163-749, and 3m Chamber N-type Cable (Setup this one for testing EUT)								
Substitution: Dipole S/N: 00164753, 3m SMA Cable Warehouse.								
f MHz	SG reading (dBm)	Ant. Pol. (H/V)	Cable Loss (dB)	Antenna Gain (dBd)	ERP (dBm)	Limit (dBm)	Margin (dB)	Notes
Low Ch								
824.20	21.22	V	1.1	-1.6	18.60	38.5	-19.9	
824.20	29.10	H	1.1	-1.6	26.48	38.5	-12.0	
Mid Ch								
836.60	20.93	V	1.1	-1.4	18.44	38.5	-20.0	
836.60	28.54	H	1.1	-1.4	26.05	38.5	-12.4	
High Ch								
848.80	20.81	V	1.1	-1.3	18.45	38.5	-20.0	
848.80	28.72	H	1.1	-1.3	26.36	38.5	-12.1	
Rev. 3.17.11								
Note: For Band 13/17 ERP limit is 34.77dBm; For Band 26 limit is 50dBm								

GSM
GSM850

GSM 1900

GSM GSM1900		High Frequency Substitution Measurement UL Korea, Ltd. Suwon Laboratory Chamber 2						
		Company: Samsung Project #: 16K23807 Date: 09-06-16 Test Engineer: YH Lim Configuration: EUT ONLY, X Position Mode: GPRS 1900MHz <u>Test Equipment:</u> Receiving: 3117[00168724] and Chamber 1 SMA Cables Substitution: 3115[00161451] Substitution, 3m SMA Cable Warehouse						
f GHz	SG reading (dBm)	Ant. Pol. (H/V)	Cable Loss (dB)	Antenna Gain (dBi)	EIRP (dBm)	Limit (dBm)	Delta (dB)	Notes
Low Ch								
1850.20	21.3	V	1.60	8.80	28.50	33.0	-4.5	
1850.20	23.7	H	1.60	8.80	30.91	33.0	-2.1	
Mid Ch								
1880.00	22.9	V	1.62	8.62	29.91	33.0	-3.1	
1880.00	24.1	H	1.62	8.62	31.08	33.0	-1.9	
High Ch								
1909.80	22.3	V	1.63	8.44	29.06	33.0	-3.9	
1909.80	24.6	H	1.63	8.44	31.37	33.0	-1.6	
Rev. 3.17.11								

WCDMA Band 5

High Frequency Substitution Measurement UL Korea, Ltd. Suwon Laboratory Chamber 2									
WCDMA Band 5 REL99	Company:		Samsung						
	Project #:		16K23807						
	Date:		02-16-09						
	Test Engineer:		YH Lim						
	Configuration:		EUT ONLY, X Position						
	Mode:		Rel 99_850 MHz						
	Test Equipment:								
	Receiving: VULB9163-749, and 3m Chamber N-type Cable (Setup this one for testing EUT)								
	Substitution: Dipole S/N: 00164753, 3m SMA Cable Warehouse.								
	f MHz	SG reading (dBm)	Ant. Pol. (H/V)	Cable Loss (dB)	Antenna Gain (dBd)	ERP (dBm)	Limit (dBm)	Margin (dB)	Notes
Low Ch									
826.40	12.38	V	1.1	-1.5	9.77	38.5	-28.7		
826.40	19.40	H	1.1	-1.5	16.79	38.5	-21.7		
Mid Ch									
836.60	10.80	V	1.1	-1.4	8.31	38.5	-30.1		
836.60	18.91	H	1.1	-1.4	16.42	38.5	-22.0		
High Ch									
846.60	11.11	V	1.1	-1.3	8.73	38.5	-29.7		
846.60	20.80	H	1.1	-1.3	18.42	38.5	-20.0		
Rev. 3.17.11									

High Frequency Substitution Measurement UL Korea, Ltd. Suwon Laboratory Chamber 2									
WCDMA Band 5 HSDPA	Company:		Samsung						
	Project #:		16K23807						
	Date:		02-16-09						
	Test Engineer:		YH Lim						
	Configuration:		EUT ONLY, X Position						
	Mode:		HSDPA_850 MHz						
	Test Equipment:								
	Receiving: VULB9163-749, and 3m Chamber N-type Cable (Setup this one for testing EUT)								
	Substitution: Dipole S/N: 00164753, 3m SMA Cable Warehouse.								
	f MHz	SG reading (dBm)	Ant. Pol. (H/V)	Cable Loss (dB)	Antenna Gain (dBd)	ERP (dBm)	Limit (dBm)	Margin (dB)	Notes
Low Ch									
826.40	12.52	V	1.1	-1.5	9.91	38.5	-28.5		
826.40	19.81	H	1.1	-1.5	17.20	38.5	-21.3		
Mid Ch									
836.60	10.28	V	1.1	-1.4	7.79	38.5	-30.7		
836.60	17.98	H	1.1	-1.4	15.49	38.5	-23.0		
High Ch									
846.60	11.70	V	1.1	-1.3	9.32	38.5	-29.1		
846.60	20.78	H	1.1	-1.3	18.40	38.5	-20.1		
Rev. 3.17.11									

WCDMA Band 2

WCDMA Band 2 REL99		High Frequency Substitution Measurement UL Korea, Ltd. Suwon Laboratory Chamber 2							
		Company: Samsung		Project #: 16K23807		Date: 09-06-16		Test Engineer: YH Lim	
		Configuration: EUT ONLY, X Position		Mode: REL99_1900 MHz					
		Test Equipment: Receiving: 3117[00168724] and Chamber 1 SMA Cables Substitution: 3115[00161451] Substitution, 3m SMA Cable Warehouse							
f MHz	SG reading (dBm)	Ant. Pol. (H/V)	Cable Loss (dB)	Antenna Gain (dBi)	EIRP (dBm)	Limit (dBm)	Margin (dB)	Notes	
Low Ch									
1852.40	13.29	V	1.60	8.79	20.48	33.0	-12.5		
1852.40	15.31	H	1.60	8.79	22.50	33.0	-10.5		
Mid Ch									
1880.00	14.25	V	1.62	8.62	21.25	33.0	-11.7		
1880.00	15.88	H	1.62	8.62	22.88	33.0	-10.1		
High Ch									
1907.60	14.23	V	1.63	8.45	21.05	33.0	-11.9		
1907.60	15.58	H	1.63	8.45	22.40	33.0	-10.6		
Rev. 3.17.11 Note: For Band 4 EIRP limit is 30dBm									

WCDMA Band 2 HSDPA		High Frequency Substitution Measurement UL Korea, Ltd. Suwon Laboratory Chamber 2							
		Company: Samsung		Project #: 16K23807		Date: 09-06-16		Test Engineer: YH Lim	
		Configuration: EUT ONLY, X Position		Mode: HSDPA_1900 MHz					
		Test Equipment: Receiving: 3117[00168724] and Chamber 1 SMA Cables Substitution: 3115[00161451] Substitution, 3m SMA Cable Warehouse							
f MHz	SG reading (dBm)	Ant. Pol. (H/V)	Cable Loss (dB)	Antenna Gain (dBi)	EIRP (dBm)	Limit (dBm)	Margin (dB)	Notes	
Low Ch									
1852.40	12.49	V	1.60	8.79	19.68	33.0	-13.3		
1852.40	16.65	H	1.60	8.79	23.84	33.0	-9.2		
Mid Ch									
1880.00	12.59	V	1.62	8.62	19.59	33.0	-13.4		
1880.00	16.34	H	1.62	8.62	23.34	33.0	-9.7		
High Ch									
1907.60	12.56	V	1.63	8.45	19.38	33.0	-13.6		
1907.60	16.98	H	1.63	8.45	23.80	33.0	-9.2		
Rev. 3.17.11 Note: For Band 4 EIRP limit is 30dBm									

8.2. FIELD STRENGTH OF SPURIOUS RADIATION

RULE PART(S)

FCC: §2.1053, §22.917 and §24.238

LIMIT

The power of any emission outside of the authorized operating frequency ranges must be attenuated below the transmitting power (P) by a factor of at least $43 + 10 \log (P)$ dB.

TEST PROCEDURE

For Cellular equipment - Compliance with these rules is based on the use of measurement instrumentation employing a resolution bandwidth of 100 kHz or greater. In the 1 MHz bands immediately outside and adjacent to the frequency block a resolution bandwidth of at least one percent of the emission bandwidth of the fundamental emission of the transmitter may be employed. A narrower resolution bandwidth is permitted in all cases to improve measurement accuracy provided the measured power is integrated over the full required measurement bandwidth (i.e. 100 kHz or 1 percent of emission bandwidth, as specified). The emission bandwidth is defined as the width of the signal between two points, one below the carrier center frequency and one above the carrier center frequency, outside of which all emissions are attenuated at least 26 dB below the transmitter power.

For PCS equipment - Compliance with these rules is based on the use of measurement instrumentation employing a resolution bandwidth of 1 MHz or greater. However, in the 1 MHz bands immediately outside and adjacent to the frequency block a resolution bandwidth of at least one percent of the emission bandwidth of the fundamental emission of the transmitter may be employed. A narrower resolution bandwidth is permitted in all cases to improve measurement accuracy provided the measured power is integrated over the full required measurement bandwidth (i.e. 1 MHz or 1 percent of emission bandwidth, as specified). The emission bandwidth is defined as the width of the signal between two points, one below the carrier center frequency and one above the carrier center frequency, outside of which all emissions are attenuated at least 26 dB below the transmitter power.

RESULTS

8.2.1. SPURIOUS RADIATION TEST RESULT

GSM 850

UL Korea, Ltd Suwon Laboratory Above 1GHz High Frequency Substitution Measurement									
Company:		Samsung							
Project #:		16K23807							
Date:		09-01-16							
Test Engineer:		YH Lim							
Configuration:		EUT / AC Adapter / Earphone, X Position							
Mode:		GPRS 850 MHz							
Chamber		Pre-amplifier			Filter		Limit		
Chamber 2		AFS42			Filter 1		Part 22		
f GHz	SG reading (dBm)	Ant. Pol. (H/V)	Distance (m)	Preamp (dB)	Filter (dB)	EIRP (dBm)	Limit (dBm)	Delta (dB)	Notes
Low Ch, 824.2MHz									
1.6484	1.9	V	3.0	39.1	1.0	-36.2	-13.0	-23.2	
2.4726	-6.4	V	3.0	39.5	1.0	-44.9	-13.0	-31.9	
3.2968	-10.7	V	3.0	40.1	1.0	-49.8	-13.0	-36.8	
1.6484	6.0	H	3.0	39.1	1.0	-32.1	-13.0	-19.1	
2.4726	-8.2	H	3.0	39.5	1.0	-46.7	-13.0	-33.7	
3.2968	-9.3	H	3.0	40.1	1.0	-48.4	-13.0	-35.4	
Mid Ch, 836.6MHz									
1.6730	-1.7	V	3.0	39.1	1.0	-39.8	-13.0	-26.8	
2.5098	-2.2	V	3.0	39.5	1.0	-40.7	-13.0	-27.7	
3.3464	-8.5	V	3.0	40.1	1.0	-47.7	-13.0	-34.7	
1.6730	2.2	H	3.0	39.1	1.0	-36.0	-13.0	-23.0	
2.5098	-2.9	H	3.0	39.5	1.0	-41.4	-13.0	-28.4	
3.3464	-7.0	H	3.0	40.1	1.0	-46.1	-13.0	-33.1	
High Ch, 848.8MHz									
1.6976	-1.8	V	3.0	39.1	1.0	-39.9	-13.0	-26.9	
2.5466	-4.7	V	3.0	39.6	1.0	-43.3	-13.0	-30.3	
3.3952	-8.2	V	3.0	40.2	1.0	-47.4	-13.0	-34.4	
1.6976	1.7	H	3.0	39.1	1.0	-36.4	-13.0	-23.4	
2.5466	-1.6	H	3.0	39.6	1.0	-40.2	-13.0	-27.2	
3.3952	-4.6	H	3.0	40.2	1.0	-43.8	-13.0	-30.8	
Rev. 03.03.09									
Note: No other emissions were detected above the system noise floor.									

GSM
GSM850

GSM 1900

UL Korea, Ltd Suwon Laboratory Above 1GHz High Frequency Substitution Measurement									
Company:		Samsung							
Project #:		16K23807							
Date:		09-06-16							
Test Engineer:		YH Lim							
Configuration:		EUT / AC Adapter / Earphone, X Position							
Mode:		GPRS 1900							
Chamber		Pre-amplifer		Filter		Limit			
Chamber 2		AFS42		Filter 1		Part 24			
f GHz	SG reading (dBm)	Ant. Pol. (H/V)	Distance (m)	Preamp (dB)	Filter (dB)	EIRP (dBm)	Limit (dBm)	Delta (dB)	Notes
Low Ch, 1850.2MHz									
3.7004	-15.5	V	3.0	40.5	1.0	-55.0	-13.0	-42.0	
5.5506	1.3	V	3.0	40.8	1.0	-38.5	-13.0	-25.5	
7.4008	2.8	V	3.0	40.8	1.0	-37.0	-13.0	-24.0	
3.7004	-13.0	H	3.0	40.5	1.0	-52.5	-13.0	-39.5	
5.5506	-6.4	H	3.0	40.8	1.0	-46.2	-13.0	-33.2	
7.4008	-2.5	H	3.0	40.8	1.0	-42.3	-13.0	-29.3	
Mid Ch, 1880.0MHz									
3.7600	-12.9	V	3.0	40.5	1.0	-52.4	-13.0	-39.4	
5.6400	-0.9	V	3.0	40.8	1.0	-40.7	-13.0	-27.7	
7.5200	-1.6	V	3.0	40.7	1.0	-41.3	-13.0	-28.3	
3.7600	-8.9	H	3.0	40.5	1.0	-48.5	-13.0	-35.5	
5.6400	-4.9	H	3.0	40.8	1.0	-44.7	-13.0	-31.7	
7.5200	-4.0	H	3.0	40.7	1.0	-43.7	-13.0	-30.7	
High Ch, 1909.8 MHz									
3.8196	-10.4	V	3.0	40.6	1.0	-50.0	-13.0	-37.0	
5.7294	-0.4	V	3.0	40.8	1.0	-40.2	-13.0	-27.2	
7.6392	-6.1	V	3.0	40.7	1.0	-45.7	-13.0	-32.7	
3.8196	-7.1	H	3.0	40.6	1.0	-46.7	-13.0	-33.7	
5.7294	-2.6	H	3.0	40.8	1.0	-42.4	-13.0	-29.4	
7.6392	-9.6	H	3.0	40.7	1.0	-49.2	-13.0	-36.2	
Rev. 03.03.09									
Note: No other emissions were detected above the system noise floor.									

GSM
GSM1900

WCDMA Band 5

UL Korea, Ltd Suwon Laboratory Above 1GHz High Frequency Substitution Measurement									
Company:		Samsung							
Project #:		16K23807							
Date:		02-16-09							
Test Engineer:		YH Lim							
Configuration:		EUT / AC Adapter / Earphone / X Position							
Mode:		Tx, REL99,850MHz							
Chamber		Pre-amplifier		Filter		Limit			
Chamber 2		AFS42		Filter 1		Part 22			
f GHz	SG reading (dBm)	Ant. Pol. (H/V)	Distance (m)	Preamp (dB)	Filter (dB)	EIRP (dBm)	Limit (dBm)	Delta (dB)	Notes
Low Ch, 826.40MHz									
1.6520	-15.9	V	3.0	39.1	1.0	-54.0	-13.0	-41.0	
2.4790	-15.9	V	3.0	39.5	1.0	-54.4	-13.0	-41.4	
3.3056	-18.2	V	3.0	40.1	1.0	-57.3	-13.0	-44.3	
1.6520	-13.2	H	3.0	39.1	1.0	-51.3	-13.0	-38.3	
2.4790	-15.1	H	3.0	39.5	1.0	-53.6	-13.0	-40.6	
3.3056	-18.8	H	3.0	40.1	1.0	-57.9	-13.0	-44.9	
Mid Ch, 836.6MHz									
1.6732	-14.6	V	3.0	39.1	1.0	-52.7	-13.0	-39.7	
2.5098	-17.7	V	3.0	39.5	1.0	-56.2	-13.0	-43.2	
3.3464	-20.2	V	3.0	40.1	1.0	-59.3	-13.0	-46.3	
1.6732	-12.0	H	3.0	39.1	1.0	-50.1	-13.0	-37.1	
2.5098	-16.2	H	3.0	39.5	1.0	-54.7	-13.0	-41.7	
3.3464	-21.0	H	3.0	40.1	1.0	-60.1	-13.0	-47.1	
High Ch, 846.6MHz									
1.6932	-14.6	V	3.0	39.1	1.0	-52.8	-13.0	-39.8	
2.5390	-18.8	V	3.0	39.6	1.0	-57.3	-13.0	-44.3	
3.3860	-18.8	V	3.0	40.2	1.0	-58.0	-13.0	-45.0	
1.6932	-14.2	H	3.0	39.1	1.0	-52.3	-13.0	-39.3	
2.5390	-16.3	H	3.0	39.6	1.0	-54.9	-13.0	-41.9	
3.3860	-20.3	H	3.0	40.2	1.0	-59.5	-13.0	-46.5	
Rev. 03.03.09									
Note: No other emissions were detected above the system noise floor.									

WCDMA
 Band 5
 REL99

UL Korea, Ltd Suwon Laboratory Above 1GHz High Frequency Substitution Measurement									
Company: Samsung Project #: 16K23807 Date: 02-16-09 Test Engineer: YH Lim Configuration: EUT / AC Adapter / Earphone / X Position Mode: Tx, HSDPA,850MHz									
		Chamber	Pre-amplifier		Filter		Limit		
		Chamber 2	AFS42		Filter 1		Part 22		
f GHz	SG reading (dBm)	Ant. Pol. (H/V)	Distance (m)	Preamp (dB)	Filter (dB)	EIRP (dBm)	Limit (dBm)	Delta (dB)	Notes
Low Ch, 826.40MHz									
1.6520	-15.6	V	3.0	39.1	1.0	-53.8	-13.0	-40.8	
2.4790	-15.2	V	3.0	39.5	1.0	-53.7	-13.0	-40.7	
3.3056	-18.0	V	3.0	40.1	1.0	-57.1	-13.0	-44.1	
1.6520	-10.5	H	3.0	39.1	1.0	-48.6	-13.0	-35.6	
2.4790	-12.4	H	3.0	39.5	1.0	-50.9	-13.0	-37.9	
3.3056	-17.7	H	3.0	40.1	1.0	-56.8	-13.0	-43.8	
Mid Ch, 836.6MHz									
1.6732	-15.9	V	3.0	39.1	1.0	-54.0	-13.0	-41.0	
2.5098	-18.6	V	3.0	39.5	1.0	-57.1	-13.0	-44.1	
3.3464	-20.3	V	3.0	40.1	1.0	-59.5	-13.0	-46.5	
1.6732	-13.1	H	3.0	39.1	1.0	-51.2	-13.0	-38.2	
2.5098	-16.8	H	3.0	39.5	1.0	-55.3	-13.0	-42.3	
3.3464	-20.9	H	3.0	40.1	1.0	-60.0	-13.0	-47.0	
High Ch, 846.6MHz									
1.6932	-15.9	V	3.0	39.1	1.0	-54.0	-13.0	-41.0	
2.5390	-18.6	V	3.0	39.6	1.0	-57.2	-13.0	-44.2	
3.3860	-19.8	V	3.0	40.2	1.0	-59.0	-13.0	-46.0	
1.6932	-13.1	H	3.0	39.1	1.0	-51.2	-13.0	-38.2	
2.5390	-14.7	H	3.0	39.6	1.0	-53.3	-13.0	-40.3	
3.3860	-20.5	H	3.0	40.2	1.0	-59.7	-13.0	-46.7	
Rev. 03.03.09 Note: No other emissions were detected above the system noise floor.									

WCDMA
Band 5
HSDPA

WCDMA Band 2

		UL Korea, Ltd Suwon Laboratory Above 1GHz High Frequency Substitution Measurement									
WCDMA Band 2 REL99	Company: Samsung Project #: 16K23807 Date: 09-06-16 Test Engineer: YH Lim Configuration: EUT / AC Adapter / Earphone / X Position Mode: Tx, REL99,1900MHz										
	Chamber		Pre-amplifier		Filter		Limit				
	Chamber 2		AFS42		Filter 1		Part 24				
	f GHz	SG reading (dBm)	Ant. Pol. (H/V)	Distance (m)	Preamp (dB)	Filter (dB)	EIRP (dBm)	Limit (dBm)	Delta (dB)	Notes	
	Low Ch, 1852.4MHz										
	3.7048	-14.8	V	3.0	40.5	1.0	-54.3	-13.0	-41.3		
	5.5572	-18.5	V	3.0	40.8	1.0	-58.3	-13.0	-45.3		
	7.4096	-16.8	V	3.0	40.8	1.0	-56.6	-13.0	-43.6		
	3.7048	-14.4	H	3.0	40.5	1.0	-53.9	-13.0	-40.9		
	5.5572	-18.8	H	3.0	40.8	1.0	-58.6	-13.0	-45.6		
	7.4096	-17.1	H	3.0	40.8	1.0	-56.9	-13.0	-43.9		
	Mid Ch, 1880MHz										
	3.7600	-14.9	V	3.0	40.5	1.0	-54.4	-13.0	-41.4		
	5.6400	-18.3	V	3.0	40.8	1.0	-58.1	-13.0	-45.1		
	7.5200	-17.1	V	3.0	40.7	1.0	-56.8	-13.0	-43.8		
	3.7600	-16.8	H	3.0	40.5	1.0	-56.4	-13.0	-43.4		
	5.6400	-18.9	H	3.0	40.8	1.0	-58.7	-13.0	-45.7		
	7.5200	-17.1	H	3.0	40.7	1.0	-56.9	-13.0	-43.9		
	High Ch, 1907.6MHz										
	3.8152	-12.5	V	3.0	40.6	1.0	-52.1	-13.0	-39.1		
5.7228	-18.0	V	3.0	40.8	1.0	-57.7	-13.0	-44.7			
7.6304	-16.5	V	3.0	40.7	1.0	-56.1	-13.0	-43.1			
3.8152	-13.0	H	3.0	40.6	1.0	-52.6	-13.0	-39.6			
5.7228	-18.3	H	3.0	40.8	1.0	-58.1	-13.0	-45.1			
7.6304	-16.8	H	3.0	40.7	1.0	-56.4	-13.0	-43.4			
Rev. 03.03.09 Note: No other emissions were detected above the system noise floor.											
WCDMA Band 2 HSDPA	UL Korea, Ltd Suwon Laboratory Above 1GHz High Frequency Substitution Measurement										
	Company: Samsung Project #: 16K23807 Date: 09-06-16 Test Engineer: YH Lim Configuration: EUT / AC Adapter / Earphone / X Position Mode: Tx, HSDPA,1900MHz										
	Chamber		Pre-amplifier		Filter		Limit				
	Chamber 2		AFS42		Filter 1		Part 24				
	f GHz	SG reading (dBm)	Ant. Pol. (H/V)	Distance (m)	Preamp (dB)	Filter (dB)	EIRP (dBm)	Limit (dBm)	Delta (dB)	Notes	
	Low Ch, 1852.4MHz										
	3.7048	-14.4	V	3.0	40.5	1.0	-53.9	-13.0	-40.9		
	5.5572	-18.5	V	3.0	40.8	1.0	-58.3	-13.0	-45.3		
	7.4096	-16.8	V	3.0	40.8	1.0	-56.6	-13.0	-43.6		
	3.7048	-14.2	H	3.0	40.5	1.0	-53.7	-13.0	-40.7		
	5.5572	-18.8	H	3.0	40.8	1.0	-58.6	-13.0	-45.6		
	7.4096	-16.7	H	3.0	40.8	1.0	-56.5	-13.0	-43.5		
	Mid Ch, 1880MHz										
	3.7600	-13.8	V	3.0	40.5	1.0	-53.3	-13.0	-40.3		
	5.6400	-17.9	V	3.0	40.8	1.0	-57.7	-13.0	-44.7		
	7.5200	-17.0	V	3.0	40.7	1.0	-56.7	-13.0	-43.7		
	3.7600	-15.3	H	3.0	40.5	1.0	-54.8	-13.0	-41.8		
	5.6400	-18.5	H	3.0	40.8	1.0	-58.3	-13.0	-45.3		
	7.5200	-17.0	H	3.0	40.7	1.0	-56.8	-13.0	-43.8		
	High Ch, 1907.6MHz										
3.8152	-11.0	V	3.0	40.6	1.0	-50.6	-13.0	-37.6			
5.7228	-15.9	V	3.0	40.8	1.0	-55.7	-13.0	-42.7			
7.6304	-15.9	V	3.0	40.7	1.0	-55.5	-13.0	-42.5			
3.8152	-11.5	H	3.0	40.6	1.0	-51.1	-13.0	-38.1			
5.7228	-16.8	H	3.0	40.8	1.0	-56.6	-13.0	-43.6			
7.6304	-16.7	H	3.0	40.7	1.0	-56.3	-13.0	-43.3			
Rev. 03.03.09 Note: No other emissions were detected above the system noise floor.											