



**FCC CFR47 PART 22 SUBPART H
FCC CFR47 PART 24 SUBPART E**

WWAN

CERTIFICATION TEST REPORT

FOR

GSM/WCDMA/LTE Phone + BT/BLE and DTS/UNII a/b/g/n

MODEL NUMBER : SM-G615F/DS, SM-G615FU/DS

FCC ID: A3LSMG615F

REPORT NUMBER: 4787892916-E5V1

ISSUE DATE: APR 07, 2017

Prepared for
**SAMSUNG ELECTRONICS CO., LTD.
129 SAMSUNG-RO, YEONGTONG-GU, SUWON-SI,
GYEONGGI-DO, 16677, KOREA**

Prepared by
**UL Korea, Ltd. Suwon Laboratory
218 Maeyeong-ro, Yeongtong-gu,
Suwon-si, Gyeonggi-do, 16675, Korea
TEL: (031) 337-9902
FAX: (031) 213-5433**



Revision History

<u>Rev.</u>	<u>Issue Date</u>	<u>Revisions</u>	<u>Revised By</u>
V1	04/07/17	Initial issue	Junwhan Lee

TABLE OF CONTENTS

1. ATTESTATION OF TEST RESULTS	5
2. TEST METHODOLOGY	6
3. FACILITIES AND ACCREDITATION	6
4. CALIBRATION AND UNCERTAINTY	6
4.1. MEASURING INSTRUMENT CALIBRATION	6
4.2. SAMPLE CALCULATION	6
4.3. MEASUREMENT UNCERTAINTY.....	7
5. EQUIPMENT UNDER TEST	8
5.1. DESCRIPTION OF EUT	8
5.2. MAXIMUM OUTPUT POWER (GSM)	8
5.3. DESCRIPTION OF AVAILABLE ANTENNAS	9
5.4. DESCRIPTION OF TEST SETUP.....	10
6. TEST AND MEASUREMENT EQUIPMENT	12
7. Summary Table	13
8. PEAK TO AVERAGE RATIO	14
8.1. CONDUCTED PEAK TO AVERAGE RESULT.....	14
8.2. CONDUCTED PEAK TO AVERAGE PLOTS.....	16
9. LIMITS AND CONDUCTED RESULTS	19
9.1. OCCUPIED BANDWIDTH	19
9.1.1. OCCUPIED BANDWIDTH RESULTS	19
9.1.2. OCCUPIED BANDWIDTH PLOTS.....	22
9.2. BAND EDGE EMISSIONS.....	30
9.2.1. BAND EDGE PLOTS.....	33
10.3 OUT OF BAND EMISSIONS.....	39
9.3.1. OUT OF BAND EMISSIONS PLOTS.....	42
9.4. FREQUENCY STABILITY.....	50
9.4.1. FREQUENCY STABILITY RESULTS	51
10. RADIATED TEST RESULTS	56
10.1. RADIATED POWER (ERP & EIRP).....	56
10.1.1. ERP/EIRP Results.....	57
10.1.2. ERP/EIRP DATA.....	59
10.2. FIELD STRENGTH OF SPURIOUS RADIATION.....	67
10.2.1. SPURIOUS RADIATION PLOTS.....	68

11. SETUP PHOTOS76

1. ATTESTATION OF TEST RESULTS

COMPANY NAME: SAMSUNG ELECTRONICS CO., LTD.
EUT DESCRIPTION: GSM/WCDMA/LTE Phone + BT/BLE and DTS/UNII a/b/g/n
MODEL NUMBER: SM-G615F/DS, SM-G615FU/DS
SERIAL NUMBER: R38J10CMN2H (RADIATED);
R38J10CLZ6X (CONDUCTED)
DATE TESTED: MAR 14, 2017 – APR 05, 2017

APPLICABLE STANDARDS	
STANDARD	TEST RESULTS
FCC PART 22H and 24E	Pass

UL Korea, Ltd. tested the above equipment in accordance with the requirements set forth in the above standards. All indications of Pass/Fail in this report are opinions expressed by UL Korea, Ltd. based on interpretations and/or observations of test results. Measurement Uncertainties were not taken into account and are published for informational purposes only. The test results show that the equipment tested is capable of demonstrating compliance with the requirements as documented in this report.

Note: The results documented in this report apply only to the tested sample, under the conditions and modes of operation as described herein. This document may not be altered or revised in any way unless done so by UL Korea, Ltd. and all revisions are duly noted in the revisions section. Any alteration of this document not carried out by UL Korea, Ltd. will constitute fraud and shall nullify the document. This report must not be used by the client to claim product certification, approval, or endorsement by IAS, any agency of the Federal Government, or any agency of any government.

Approved & Released For
UL Korea, Ltd. By:



SungGil Park
Suwon Lab Engineer
UL Korea, Ltd.

Tested By:



Junwhan Lee
Suwon Lab Engineer
UL Korea, Ltd.

2. TEST METHODOLOGY

The tests documented in this report were performed in accordance with following methods.

1. FCC CFR 47 Part 2.
2. FCC CFR 47 Part 22.
3. FCC CFR 47 Part 24.
4. ANSI TIA-603-D
5. KDB 971168 D01 Power Meas License Digital Systems v02r02

3. FACILITIES AND ACCREDITATION

The test sites and measurement facilities used to collect data are located at 218 Maeyeong-ro, Yeongtong-gu, Suwon-si, Gyeonggi-do, 16675, Korea. Line conducted emissions are measured only at the 218 address. The following table identifies which facilities were utilized for radiated emission measurements documented in this report. Specific facilities are also identified in the test results sections.

218 Maeyeong-ro	
<input type="checkbox"/>	Chamber 1
<input checked="" type="checkbox"/>	Chamber 2

UL Korea, Ltd. is accredited by IAS, Laboratory Code TL-637. The full scope of accreditation can be viewed at <http://www.iasonline.org/PDF/TL/TL-637.pdf>.

4. CALIBRATION AND UNCERTAINTY

4.1. MEASURING INSTRUMENT CALIBRATION

The measuring equipment utilized to perform the tests documented in this report has been calibrated in accordance with the manufacturer's recommendations, and is traceable to recognized national standards.

4.2. SAMPLE CALCULATION

Where relevant, the following sample calculation is provided:

$EIRP = \text{PSA reading with EUT worst orientation (dBm)} + \text{Path loss (dB)} - \text{cable loss (between the SG and substitution antenna)} + \text{Substitution Antenna Factor (dBi)}$

$ERP = \text{PSA reading with EUT worst orientation (dBm)} + \text{Path loss (dB)} - \text{cable loss (between the SG and substitution antenna)}$

(Path loss = Signal generator output – PSA reading with substitution antenna)

4.3. MEASUREMENT UNCERTAINTY

Where relevant, the following measurement uncertainty levels have been estimated for tests performed on the apparatus:

PARAMETER	UNCERTAINTY
Conducted Disturbance, 0.15 to 30 MHz	2.32 dB
Radiated Disturbance, Below 1GHz	4.14 dB
Radiated Disturbance, Above 1 GHz	5.97 dB

Uncertainty figures are valid to a confidence level of 95%.

5. EQUIPMENT UNDER TEST

5.1. DESCRIPTION OF EUT

The EUT is a GSM/WCDMA/LTE Phone + BT/BLE and DTS/UNII a/b/g/n.

SM-G615F/DS and SM-G615FU/DS are same H/W and only difference is Main camera led and Deco of rear side. PED document described the differences in detail. SM-G615F/DS was used for the test.

5.2. MAXIMUM OUTPUT POWER (GSM)

The transmitter has a maximum peak conducted and radiated ERP / EIRP output powers as follows:

Note : Conducted output power results excerpted from RF exposure test report.(4787892916-S1V1 FCC Report SAR)

GSM

FCC Part 22/24						
Band	Frequency Range	Modulation	Conducted		Radiated	
	[MHz]		Peak	Avg [dBm]	Avg [mW]	Avg [dBm]
GSM850	824~849	GMSK	33.35	2162.72		
		GPRS	33.38	2177.71	31.90	1548.82
		EGPRS	27.46	557.19	26.34	430.53
GSM1900	1850~1910	GMSK	29.71	935.41		
		GPRS	29.73	939.72	27.80	602.56
		EGPRS	26.50	446.68	25.26	335.74

WCDMA

FCC Part 22/24						
Band	Frequency Range	Modulation	Conducted		Radiated	
	[MHz]		Peak	Avg [dBm]	Avg [mW]	Avg [dBm]
Band 5	824~849	REL99	23.18	207.97	20.12	102.80
		HSDPA	22.21	166.34	19.02	79.80
		HSUPA	21.20	131.83		
		DC-HSDPA	22.19	165.58		
Band 2	1850~1910	REL99	22.20	165.96	20.52	112.72
		HSDPA	22.24	167.49	20.59	114.55
		HSUPA	22.39	173.38		
		DC-HSDPA	22.31	170.22		

LTE BAND5

FCC Part 22							
Band	Frequency Range [MHz]	BandWidth [MHz]	Modulation	Conducted		Radiated	
				Peak	Avg [dBm]	Avg [mW]	Avg [dBm]
Band 5	824 ~ 849	10	QPSK	23.96	248.89	19.46	88.31
			16QAM	23.42	219.79	18.46	70.15
		5	QPSK	23.86	243.22	18.27	67.14
			16QAM	23.45	221.31	17.53	56.62
		3	QPSK	23.90	245.47	16.84	48.31
			16QAM	23.34	215.77	16.21	41.78
		1.4	QPSK	23.98	250.03	15.37	34.43
			16QAM	23.10	204.17	14.39	27.48

5.3. DESCRIPTION OF AVAILABLE ANTENNAS

The radio utilizes a internal antenna for the [List the bands supported] with a maximum peak gain as follow:

Frequency (MHz)	Peak Gain (dBi)
GSM850 / WCDMA Band 5 / LTE Band 5 824 ~ 849 MHz	-4.5
GSM1900 / WCDMA Band 2 1850 ~ 1910 MHz	4.9

5.4. DESCRIPTION OF TEST SETUP

SUPPORT EQUIPMENT

Support Equipment List				
Description	Manufacturer	Model	Serial Number	FCC ID
Charger	SAMSUNG	EP-TA50EWE	DK1H822VS/A-E	N/A
Data Cable	SAMSUNG	ECB-DU68WE	N/A	N/A
Earphone	SAMSUNG	EHS64AVFWE	N/A	N/A

I/O CABLES

I/O Cable List						
Cable No	Port	# of identical ports	Connector Type	Cable Type	Cable Length (m)	Remarks
1	DC Power	1	Mini-USB	Shielded	0.8m	N/A
2	Audio	2	Mini-Jack	Unshielded	1.0m	N/A

TEST SETUP

The EUT is continuously communicated to the call box during the tests.

SETUP DIAGRAM FOR TESTS (CONDUCTED TEST SETUP)

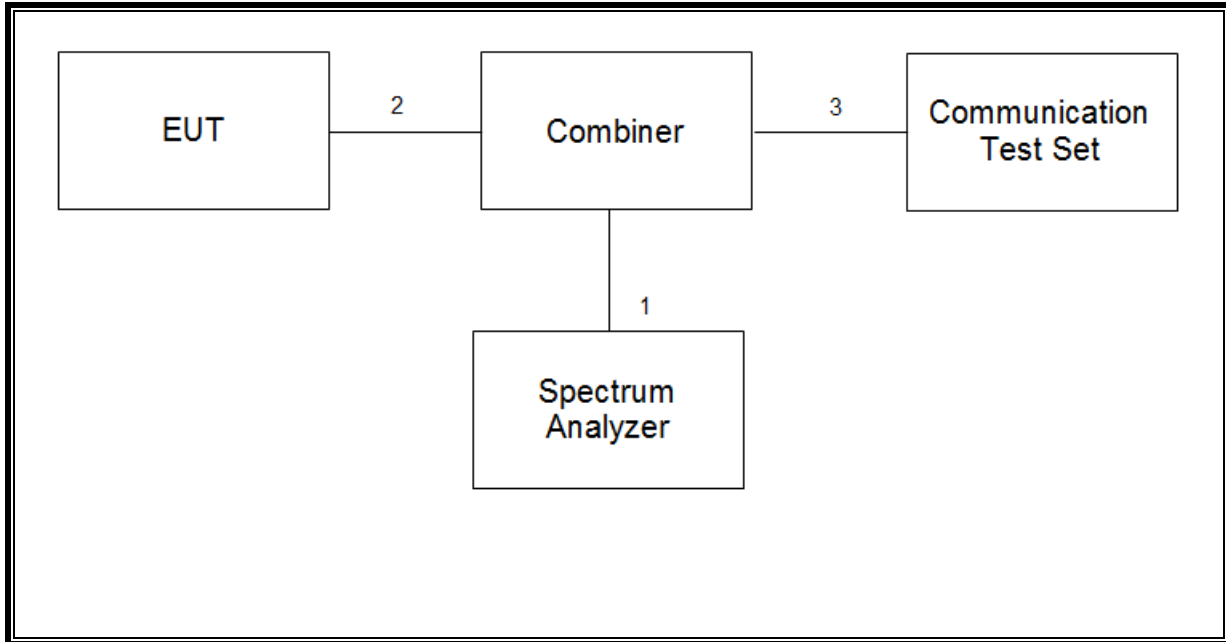

SETUP DIAGRAM FOR TESTS (RADIATED TEST SETUP)

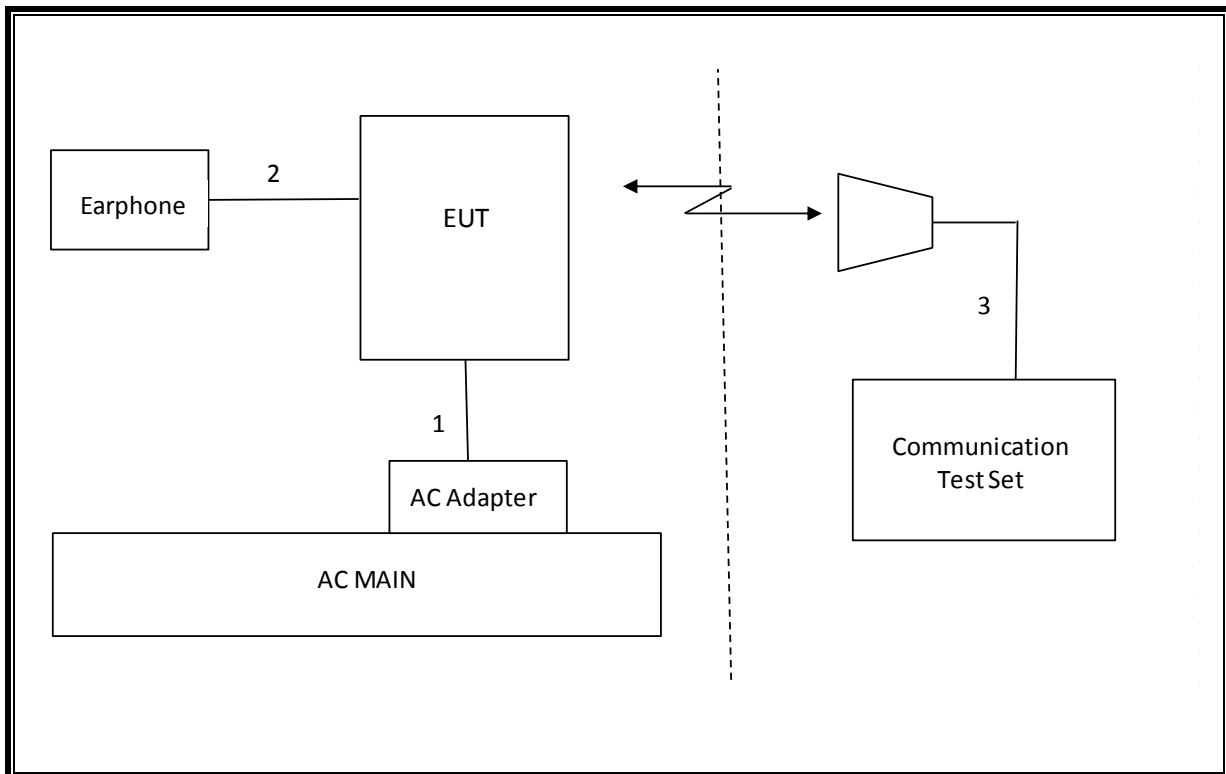

6. TEST AND MEASUREMENT EQUIPMENT

The following test and measurement equipment was utilized for the tests documented in this report:

Test Equipment List				
Description	Manufacturer	Model	S/N	Cal Due
Antenna, Tuned Dipole 400~1000 MHz	ETS	3121D DB4	00164753	07-28-17
Antenna, Horn, 40 GHz	ETS	3116C	00166155	11-30-17
Antenna, Horn, 40 GHz	ETS	3116C-PA	00168841	12-15-17
Antenna, Bilog, 30MHz-1GHz	SCHWARZBECK	VULB9163	750	10-14-18
Antenna, Bilog, 30MHz-1GHz	SCHWARZBECK	VULB9163	749	04-25-17
Antenna, Horn, 18 GHz	ETS	3115	00167211	10-14-18
Antenna, Horn, 18 GHz	ETS	3117	00168724	06-17-17
Antenna, Horn, 18 GHz	ETS	3117	00168717	06-17-17
Combiner	WEINSCHEL	1575	2154	08-17-17
Communications Test Set	R&S	CMW500	150312	08-17-17
Communications Test Set	R&S	CMW500	115331	08-17-17
DC Power Supply	Agilent / HP	E3640A	MY54226395	08-16-17
Preamplifier, 1000 MHz	Sonoma	310N	341282	08-17-17
Preamplifier, 1000 MHz	Sonoma	310N	351741	08-16-17
Preamplifier	ETS	3115-PA	00167475	08-17-17
Preamplifier, 18 GHz	Miteq	AFS42-00101800-25-S-42	1896138	08-16-17
Spectrum Analyzer, 44 GHz	Agilent / HP	N9030A	MY54170614	08-17-17
Spectrum Analyzer, 44 GHz	Agilent / HP	N9030A	MY54490312	03-09-18
EMI Test Receive, 40 GHz	R&S	ESU40	100439	08-17-17
EMI Test Receive, 40 GHz	R&S	ESU40	100457	08-16-17
High Pass Filter 1.2GHz	Micro-Tronics	HPM50108-02	G005	08-17-17
High Pass Filter 1.2GHz	Micro-Tronics	HPM50108-02	G006	08-17-17
High Pass Filter 2.8GHz	Micro-Tronics	HPM50111-02	010	08-17-17
High Pass Filter 2.8GHz	Micro-Tronics	HPM50111-02	011	08-17-17
High Pass Filter 4GHz	Micro-Tronics	HPM50118-02	G001	08-17-17
High Pass Filter 4GHz	Micro-Tronics	HPM50118-02	G002	08-17-17
Attenuator	PASTERNAK	PE7087-10	A009	08-16-17
Temperature Chamber	ESPEC	SH-642	93001109	08-17-17
UL Software				
Description	Manufacturer	Model	Version	
Antenna port test software	UL	CLT	Ver 1.6	

7. Summary Table

FCC Part Section	Test Description	Test Limit	Test Condition	Test Result	Note
2.1049	Occupied Band width (99%)	N/A	Conducted	Pass	8.9765 MHz
22.917(a) 24.238(a)	Band Edge / Conducted Spurious Emission	-13dBm		Pass	-14.495 dBm
2.1046	Conducted output power	N/A		Pass	33.38dBm
22.355 24.235	Frequency Stability	2.5PPM		Pass	-0.008 PPM
22.913(a)(2)	Effective Radiated Power	38.5 dBm	Radiated	Pass	31.90 dBm
24.232(c)	Equivalent Isotropic Radiated Power	33dBm		Pass	27.80 dBm
22.917(a) 24.238(a)	Radiated Spurious Emission	-13dBm		Pass	-26.6 dBm

FCC Rule Part	Frequency Range [MHz]	Output Power [W]	Frequency Tolerance	Emission Designator	Emission Bandwidth [MHz]	Communication Type
GSM						
22H	824.2 - 848.8	1.549	2.5 ppm	249KGXW		GSM850
22H	824.2 - 848.8	0.431	2.5 ppm	242KG7W		EDGE850
24E	1850.2 - 1909.8	0.603	2.5 ppm	246KGXW		GSM1900
24E	1850.2 - 1909.8	0.336	2.5 ppm	250KG7W		EDGE1900
WCDMA						
22H	826.4 - 846.6	0.103	2.5 ppm	4M16F9W		WCDMA B5
24E	1852.4 - 1907.6	0.115	2.5 ppm	4M17F9W		WCDMA B2
LTE Band 5						
22H	829.0 - 844.0	0.088	2.5 ppm	8M97G7W	10	QPSK
22H	829.0 - 844.0	0.070	2.5 ppm	8M98D7W	10	16QAM

8. PEAK TO AVERAGE RATIO

Test Procedure

Per KDB 971168 D01 Power Meas License Digital Systems v02r02;

The transmitter output was connected to a CMW500 Test Set and configured to operate at maximum power. The PAR were measured on the Spectrum Analyzer.

Test Spec

In addition, when the transmitter power is measured in terms of average value, the peak-to-average ratio of the power shall not exceed 13 dB.

8.1. CONDUCTED PEAK TO AVERAGE RESULT

GSM

Band	Channel	f [MHz]	Mode	Ratio [dB]	Limit [dB]
GSM850	190	836.6	GPRS	0.11	13.00
			EGPRS	3.10	
GSM1900	661	1880.0	GPRS	0.10	
			EGPRS	2.95	

WCDMA

Band	Channel	f [MHz]	Mode	Ratio [dB]	Limit [dB]
Band 5	4183	836.6	REL99	3.13	13.00
			HSDPA	3.26	
Band 2	9400	1880.0	REL99	3.01	
			HSDPA	3.08	

LTE

Band	BW [MHz]	Channel	f [MHz]	Mode	Ratio [dB]	Limit [dB]
Band 5	10	20525	836.5	QPSK	4.51	13.00
				16QAM	5.47	
	5			QPSK	4.49	
				16QAM	5.31	
	3			QPSK	4.62	
				16QAM	5.64	
	1.4			QPSK	4.64	
				16QAM	5.46	

8.2. CONDUCTED PEAK TO AVERAGE PLOTS

GSM

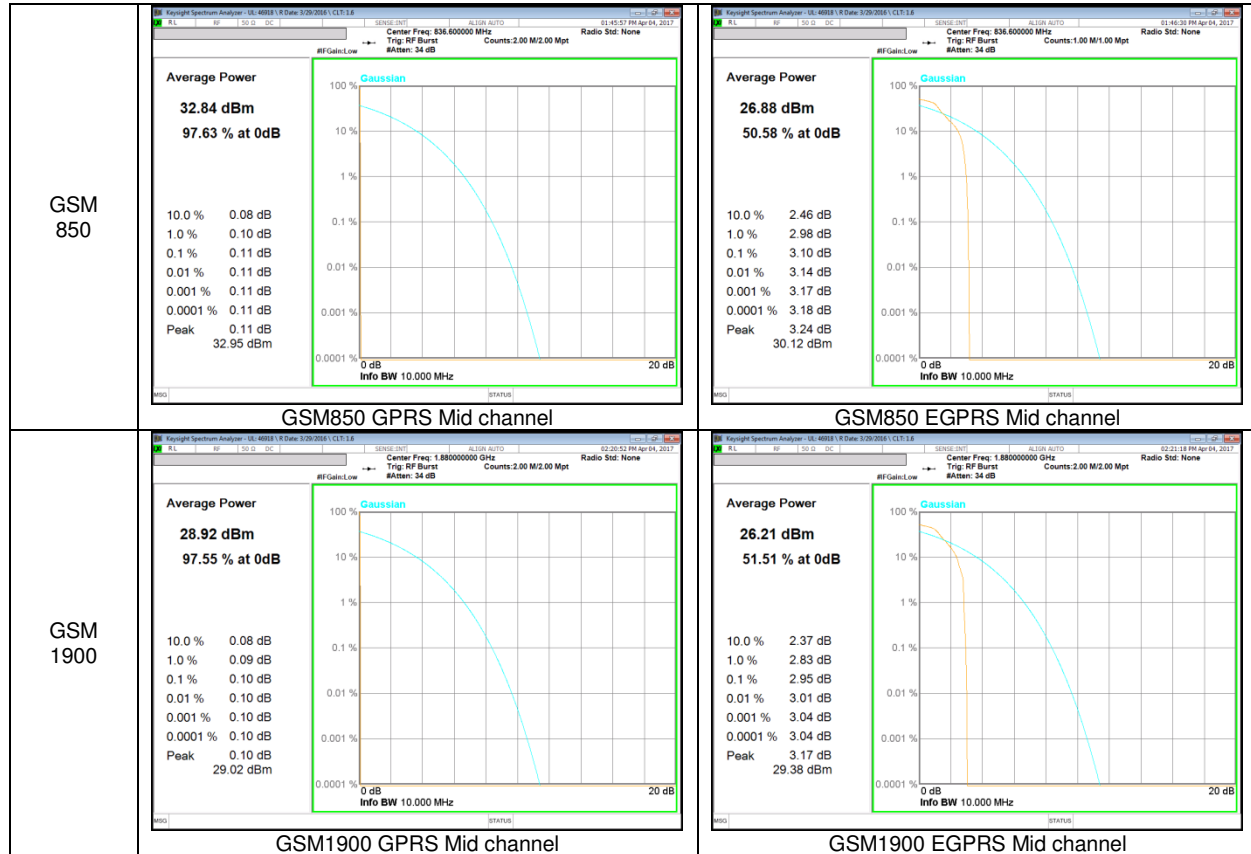

WCDMA

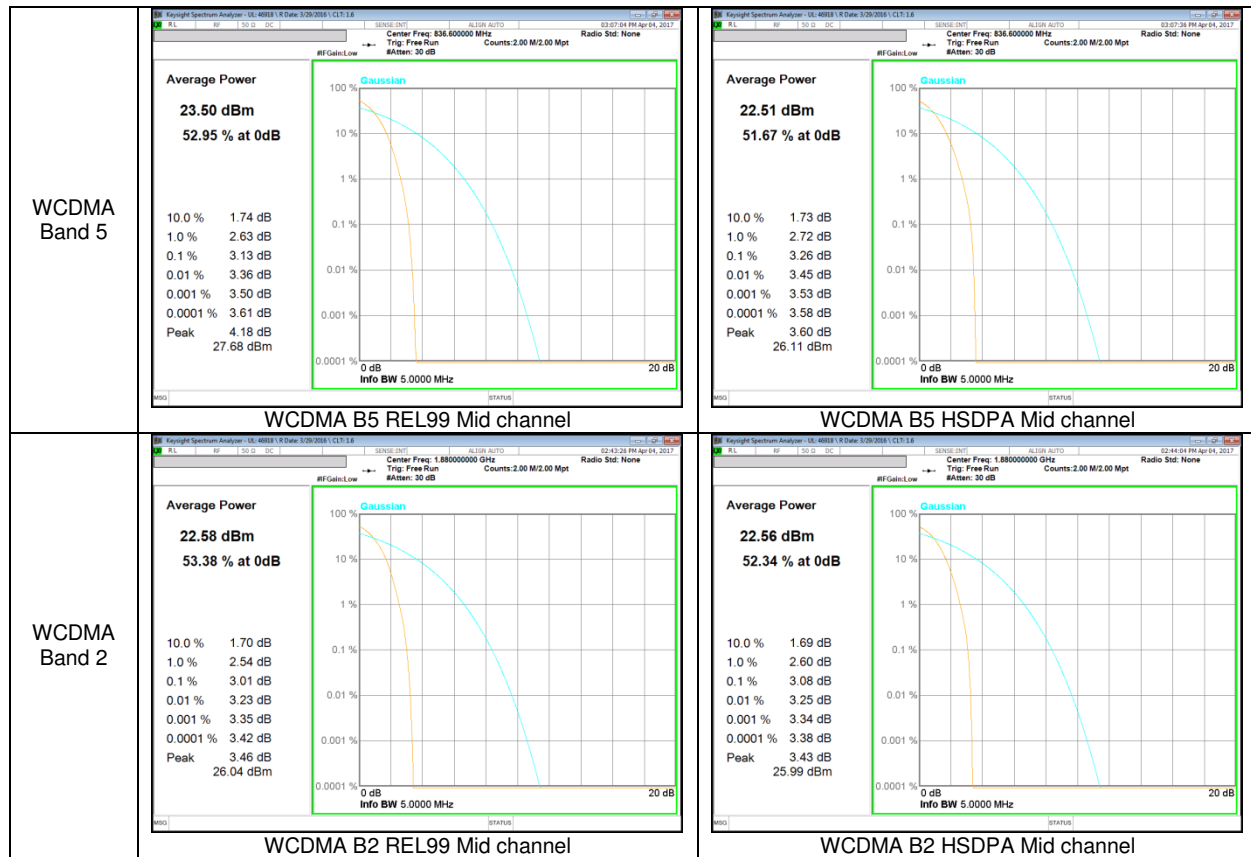

LTE Band 5

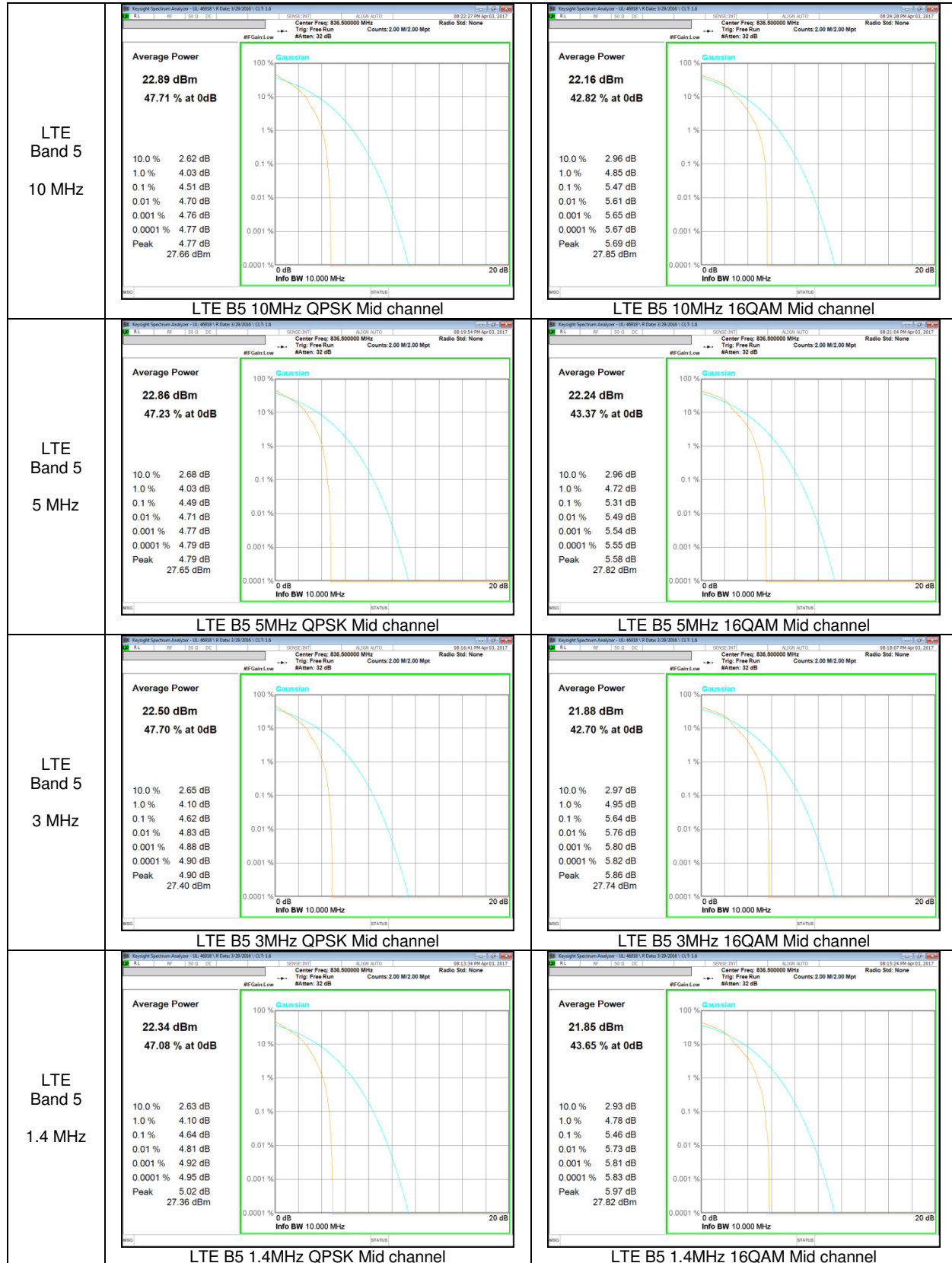

9. LIMITS AND CONDUCTED RESULTS

9.1. OCCUPIED BANDWIDTH

RULE PART(S)

FCC: §2.1049

LIMITS

For reporting purposes only

TEST PROCEDURE

The transmitter output was connected to a calibrated coaxial cable and coupler, the other end of which was connected to a spectrum analyzer. The occupied bandwidth was measured with the spectrum analyzer at the low, middle and high channel in each band. The -26dB bandwidth was also measured and recorded.

(KDB 971168 D01 Power Meas License Digital Systems v02r02)

9.1.1. OCCUPIED BANDWIDTH RESULTS

GSM

Band	Mode	Channel	f [MHz]	99% BW [KHz]	26dB BW [KHz]
GSM850	GPRS	128	824.2	242.12	314.8
		190	836.6	244.48	312.9
		251	848.8	248.64	313.9
	EGPRS	128	824.2	238.67	298.8
		190	836.6	241.95	300.3
		251	848.8	238.60	285.9
GSM1900	GPRS	512	1850.2	243.56	315.6
		661	1880.0	243.72	318.5
		810	1909.8	246.22	316.6
	EGPRS	512	1850.2	244.68	314.1
		661	1880.0	247.30	312.0
		810	1909.8	250.08	318.3

WCDMA

Band	Mode	Channel	f [MHz]	99% BW [MHz]	26dB BW [MHz]
Band 5	REL99	4132	826.4	4.1558	4.618
		4183	836.6	4.1581	4.624
		4233	846.6	4.1583	4.642
	HSDPA	4132	826.4	4.1606	4.635
		4183	836.6	4.1633	4.636
		4233	846.6	4.1572	4.635
Band 2	REL99	9262	1852.4	4.1692	4.644
		9400	1880.0	4.1551	4.638
		9538	1907.6	4.1533	4.642
	HSDPA	9262	1852.4	4.1643	4.636
		9400	1880.0	4.1509	4.633
		9538	1907.6	4.1558	4.620

LTE Band 5

Band	BW [MHz]	Channel	f [MHz]	Mode	99% BW [MHz]	26dB BW [MHz]
Band 5	10	20450	829.0	QPSK	8.9518	9.866
				16QAM	8.9729	9.873
		20524	836.5	QPSK	8.9743	9.936
				16QAM	8.9765	9.818
		20599	844.0	QPSK	8.9591	9.792
				16QAM	8.9566	9.792
	5	20425	826.5	QPSK	4.4922	5.001
				16QAM	4.4907	5.021
		20524	836.5	QPSK	4.4767	4.956
				16QAM	4.4873	5.008
		20624	846.5	QPSK	4.4848	5.026
				16QAM	4.4972	5.022
	3	20415	825.5	QPSK	2.6858	2.954
				16QAM	2.6851	2.945
		20524	836.5	QPSK	2.6903	2.957
				16QAM	2.6903	2.930
		20634	847.5	QPSK	2.6908	2.951
				16QAM	2.6859	2.961
	1.4	20407	824.7	QPSK	1.0865	1.247
				16QAM	1.0852	1.239
		20524	836.5	QPSK	1.0822	1.257
				16QAM	1.0880	1.244
		20624	848.3	QPSK	1.0902	1.262
				16QAM	1.0870	1.252

9.1.2. OCCUPIED BANDWIDTH PLOTS

GSM 850



GSM 1900



WCDMA Band 5



WCDMA Band 2



LTE Band 5

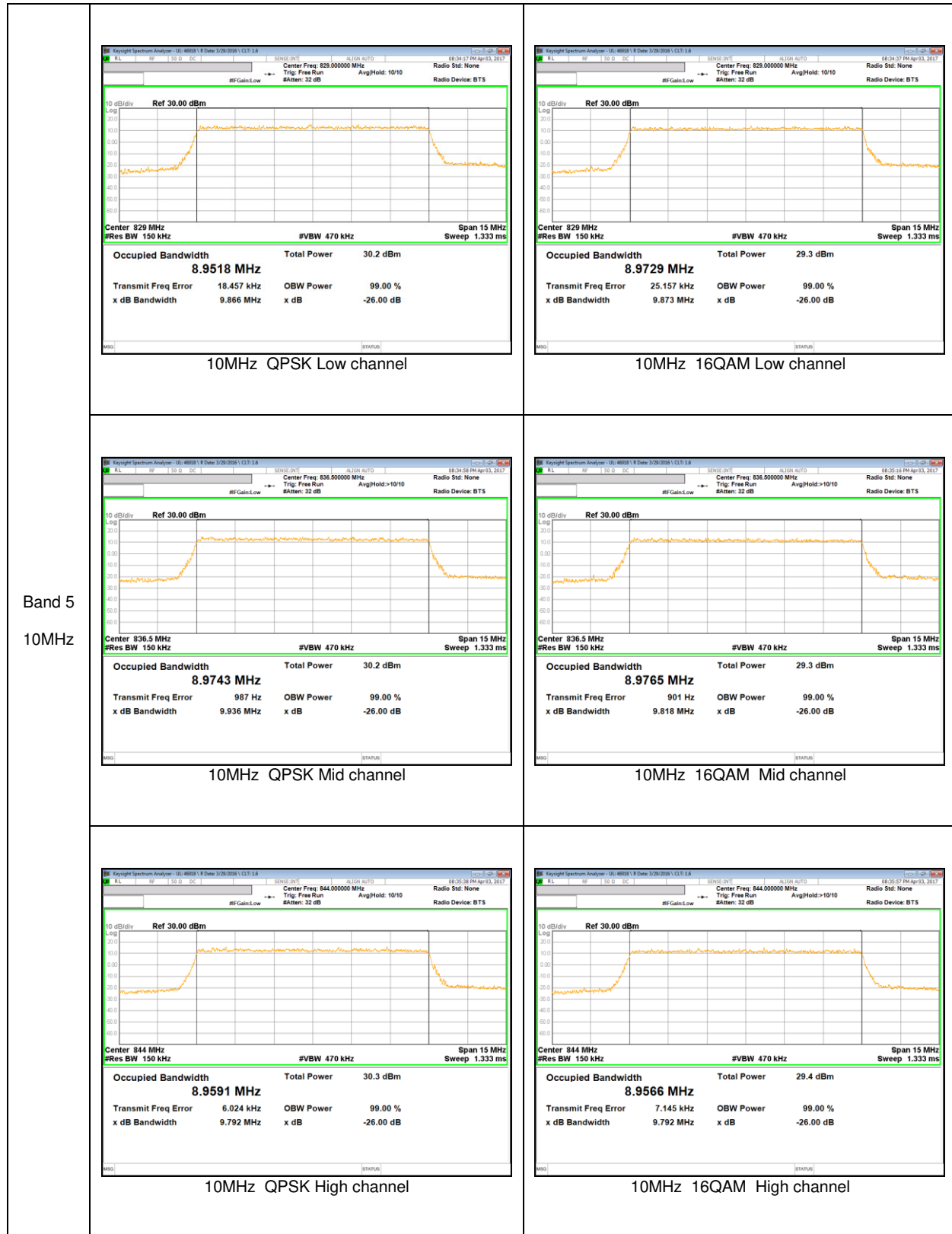

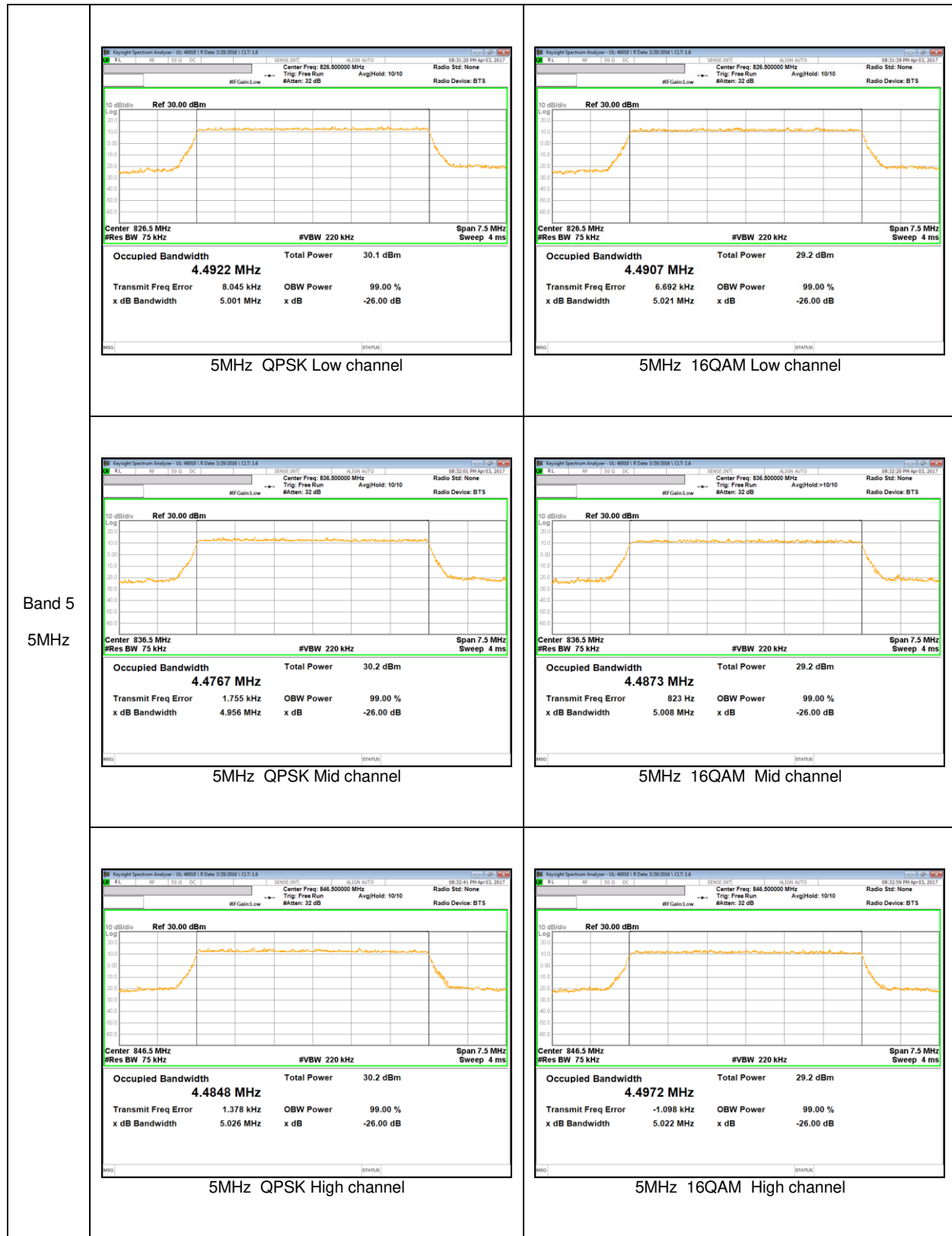

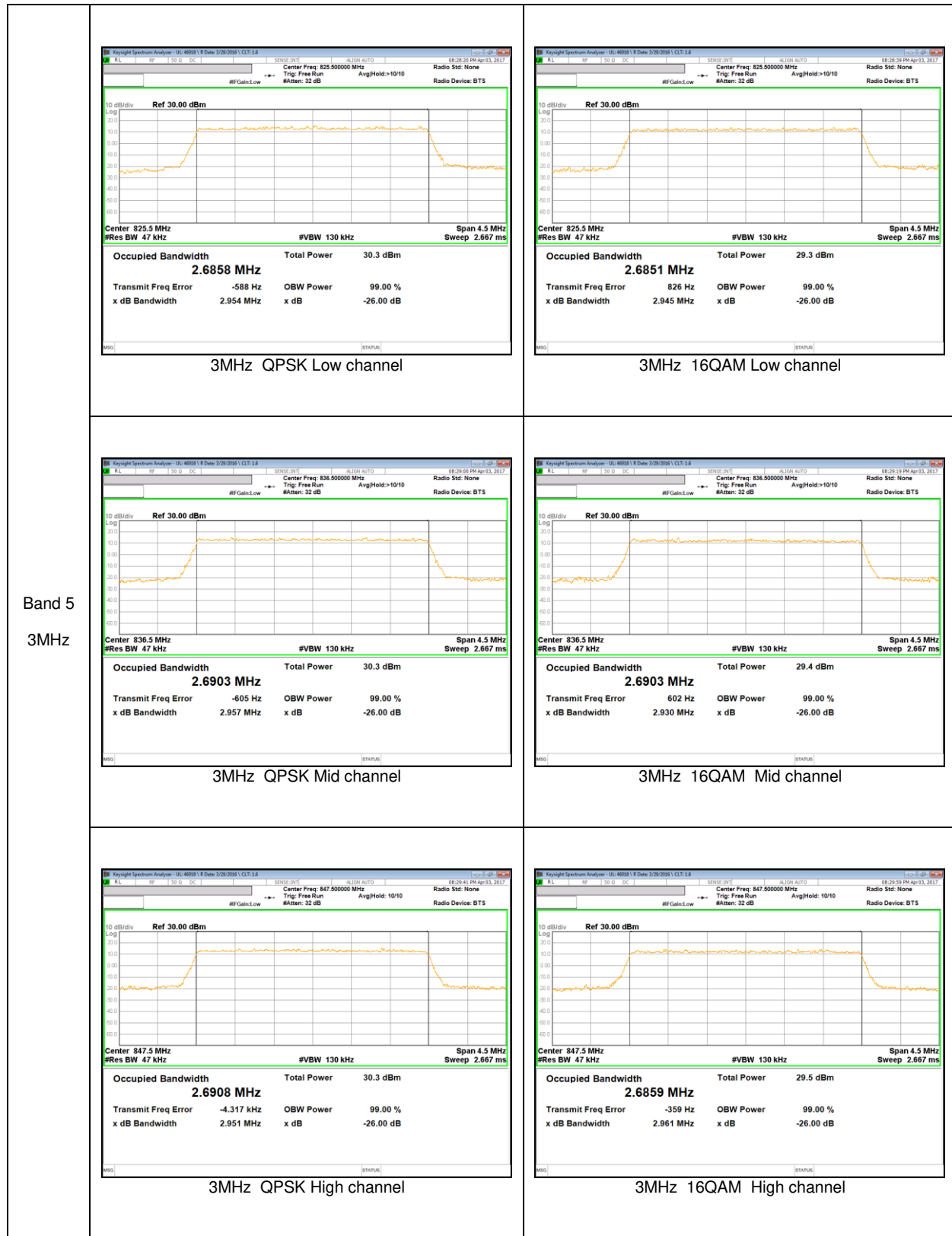

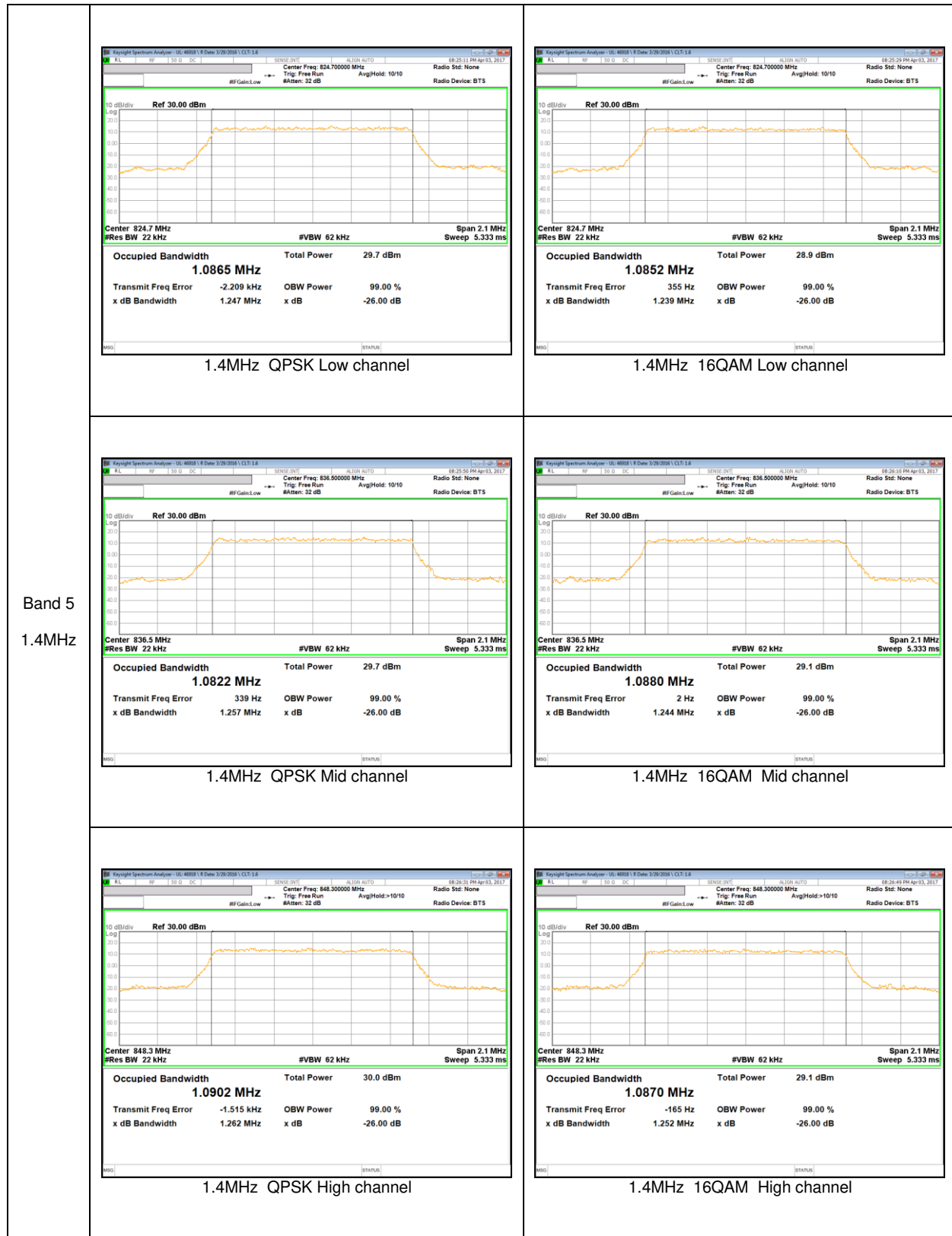

9.2. BAND EDGE EMISSIONS

RULE PART(S)

FCC: §22.359 and §24.238

LIMITS

The power of any emission outside of the authorized operating frequency ranges must be attenuated below the transmitting power (P) by a factor of at least $43 + 10 \log (P)$ dB.

TEST PROCEDURE

Per KDB 971168 D01 Power Meas License Digital Systems v02r02

The transmitter output was connected to a CMW500 Test Set and configured to operate at maximum power. The band edge emissions were measured at the required operating frequencies in each band on the Spectrum Analyzer.

GSM

- a) Set the RBW = 1 ~ 5% of OBW(GSM850 – 8.2KHz, GSM1900 – 9.1KHz)
- b) Set VBW $\geq 3 \times$ RBW;
- c) Set span ≥ 1.5 times the OBW;
- d) Sweep time = 1S ;
- e) Detector = RMS;
- f) Ensure that the number of measurement points $\geq 2 \times$ Span/RBW;
- g) Trace mode = Average(100);
- h) Add duty cycle correction factor (9dB)

WCDMA/LTE

- b) Set the RBW = 1 ~ 1.5 % of OBW(Typically limited to a minimum RBW of 1% of the OBW)
- b) Set VBW $\geq 3 \times$ RBW;
- c) Set span ≥ 1.5 times the OBW;
- d) Sweep time = Auto;
- e) Detector = RMS;
- f) Ensure that the number of measurement points $\geq 2 \times$ Span/RBW;
- g) Trace mode = Average (100);

RESULTS

GSM

Band	Mode	Side	f [MHz]	Level [dBm]	Limit [dBm]
GSM850	GPRS	Lower	823.977	-15.374	-13.00
		Upper	849.023	-14.757	
	EGPRS	Lower	823.982	-24.849	
		Upper	849.033	-25.653	
GSM1900	GPRS	Lower	1849.992	-18.824	
		Upper	1910.023	-18.498	
	EGPRS	Lower	1849.992	-24.992	
		Upper	1910.018	-25.849	

WCDMA

Band	Mode	Side	f [MHz]	Level [dBm]	Limit [dBm]
Band 5	REL99	Lower	824	-30.010	-13.00
		Upper	849	-29.891	
	HSDPA	Lower	824	-32.366	
		Upper	849	-30.998	
Band 2	REL99	Lower	1850	-33.511	
		Upper	1910	-33.073	
	HSDPA	Lower	1850	-35.154	
		Upper	1910	-33.267	

LTE 5

Bandwidth	Mode	Side	RB Status	f [MHz]	Level [dBm]	Limit [dBm]
10 MHz	QPSK	Lower	1RB	824.000	-17.703	-13.00
			FRB	824.000	-28.556	
		Upper	1RB	849.000	-15.183	
			FRB	849.000	-25.757	
	16QAM	Lower	1RB	824.000	-18.975	
			FRB	824.000	-28.510	
		Upper	1RB	849.000	-16.413	
			FRB	849.000	-27.999	
5 MHz	QPSK	Lower	1RB	824.000	-14.784	-13.00
			FRB	824.000	-26.569	
		Upper	1RB	849.000	-14.495	
			FRB	849.000	-24.037	
	16QAM	Lower	1RB	824.000	-15.064	
			FRB	824.000	-25.620	
		Upper	1RB	849.000	-14.689	
			FRB	849.000	-25.430	
3 MHz	QPSK	Lower	1RB	824.000	-15.857	-13.00
			FRB	824.000	-26.988	
		Upper	1RB	849.000	-14.835	
			FRB	849.000	-25.692	
	16QAM	Lower	1RB	824.000	-16.858	
			FRB	824.000	-27.559	
		Upper	1RB	849.000	-16.433	
			FRB	849.000	-25.099	
1.4 MHz	QPSK	Lower	1RB	824.000	-25.119	-13.00
			FRB	824.000	-29.567	
		Upper	1RB	849.000	-22.487	
			FRB	849.000	-26.628	
	16QAM	Lower	1RB	824.000	-25.653	
			FRB	824.000	-30.295	
		Upper	1RB	849.000	-21.931	
			FRB	849.000	-27.055	

9.2.1. BAND EDGE PLOTS

GSM

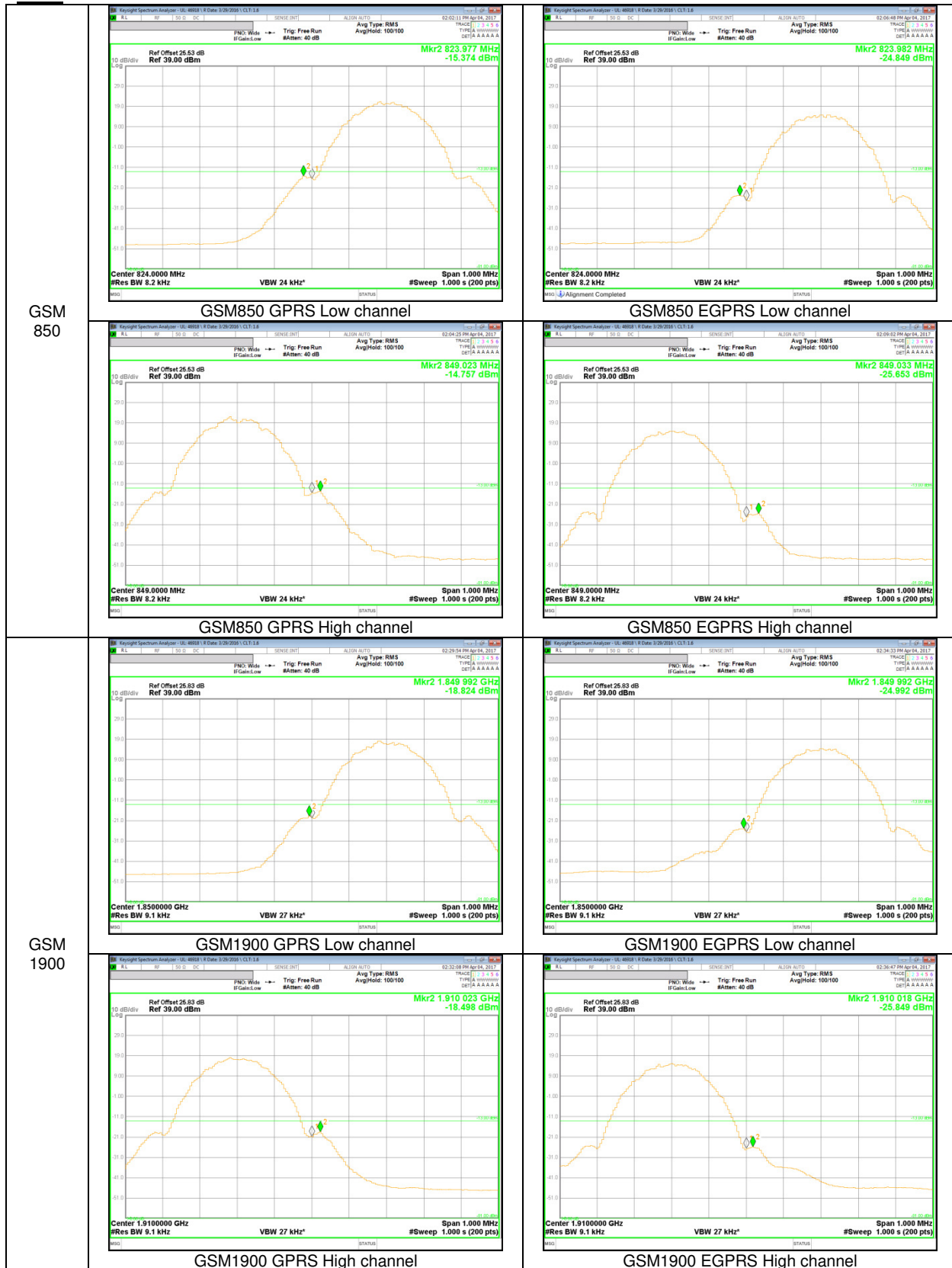

GSM
850

GSM
1900

WCDMA

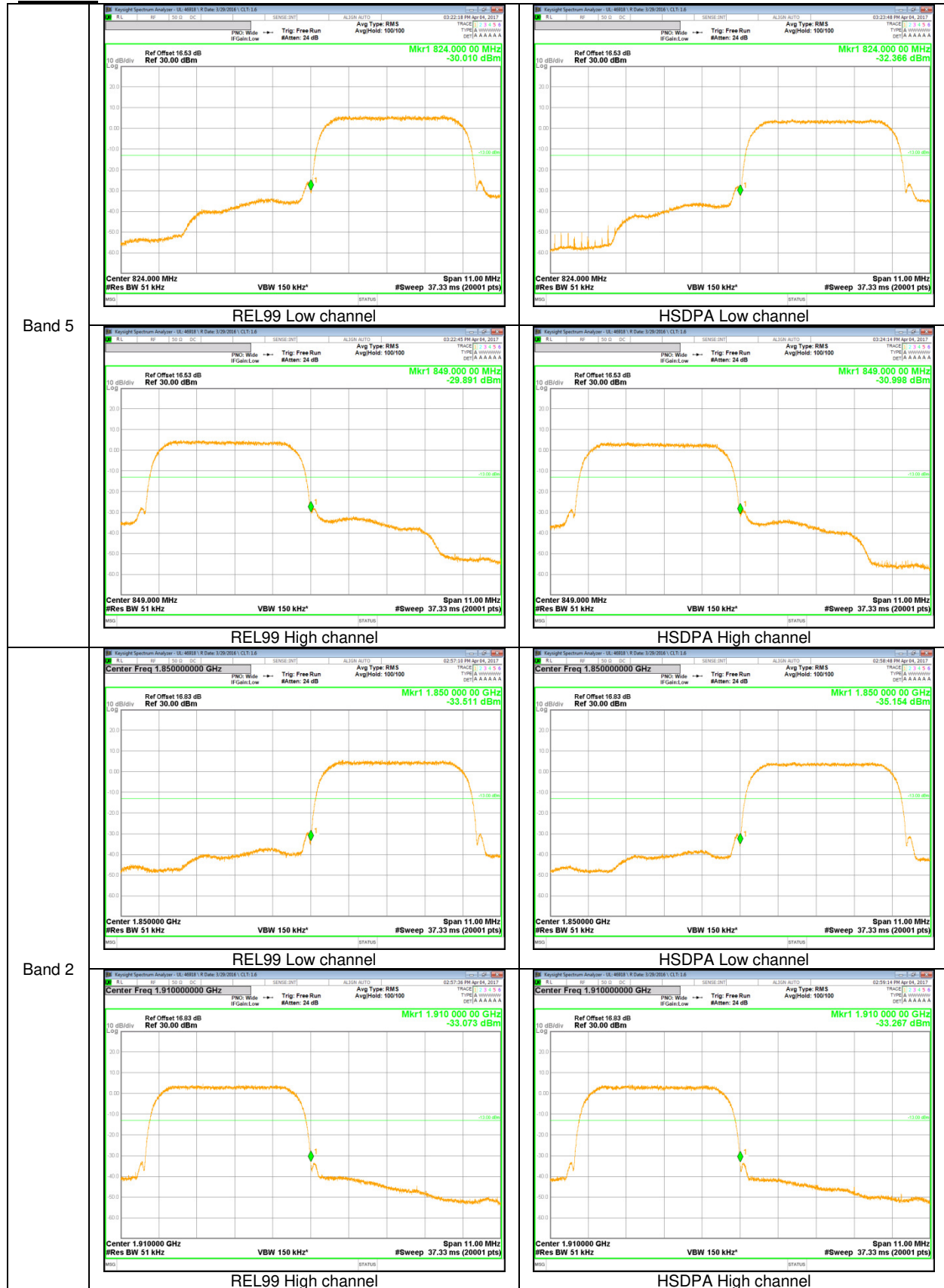

LTE Band 5

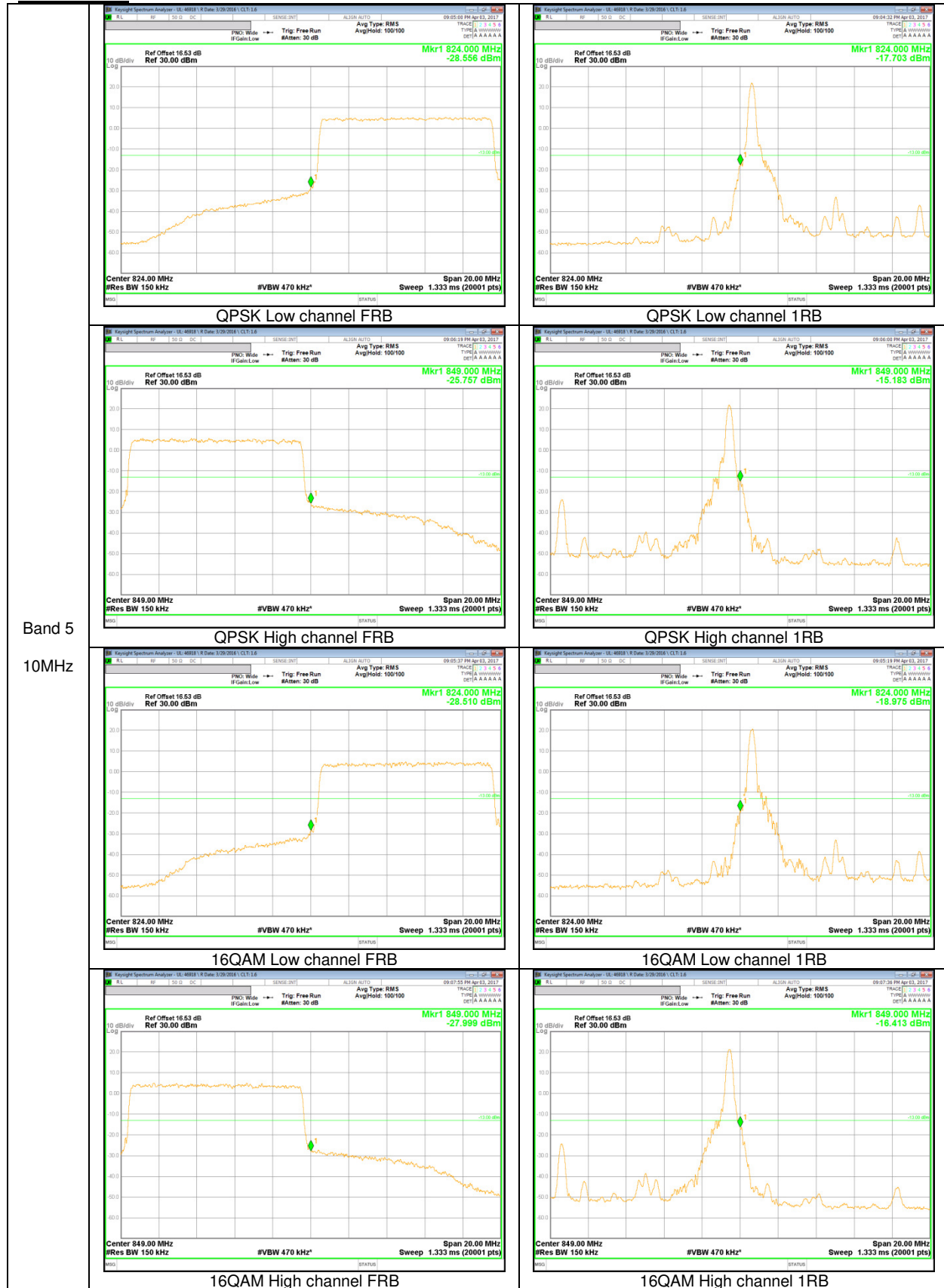

Band 5
10MHz

