



**FCC CFR47 PART 22 SUBPART H
FCC CFR47 PART 24 SUBPART E**

CERTIFICATION TEST REPORT

FOR

GSM Phone + Bluetooth/BLE and DTS b/g/n

MODEL NUMBER : SM-G361H, SM-G361H/DS

FCC ID: A3LSMG361H

REPORT NUMBER: 15K20822-E4

ISSUE DATE: JUN 01, 2015

Prepared for

**SAMSUNG ELECTRONICS CO., LTD.
129 SAMSUNG-RO, YEONGTONG-GU, SUWON-SI,
GYEONGGI-DO, 443-742, KOREA**

Prepared by

**UL Korea, Ltd. Suwon Laboratory
218 Maeyeong-ro, Yeongtong-gu,
Suwon-si, Gyeonggi-do, 443-823, Korea
TEL: (031) 337-9902
FAX: (031) 213-5433**



Revision History

<u>Rev.</u>	<u>Issue Date</u>	<u>Revisions</u>	<u>Revised By</u>
--	05/21/15	Initial issue	CY Choi
A	05/27/15	Revised form of summary table	CY Choi
B	06/01/15	Update model name and description	CY Choi

TABLE OF CONTENTS

1. ATTESTATION OF TEST RESULTS	5
2. TEST METHODOLOGY	6
3. FACILITIES AND ACCREDITATION	6
4. CALIBRATION AND UNCERTAINTY	6
4.1. <i>MEASURING INSTRUMENT CALIBRATION</i>	<i>6</i>
4.2. <i>SAMPLE CALCULATION</i>	<i>6</i>
4.3. <i>MEASUREMENT UNCERTAINTY.....</i>	<i>6</i>
5. EQUIPMENT UNDER TEST.....	7
5.1. <i>DESCRIPTION OF EUT</i>	<i>7</i>
5.2. <i>MAXIMUM OUTPUT POWER (GSM).....</i>	<i>7</i>
5.3. <i>DESCRIPTION OF AVAILABLE ANTENNAS</i>	<i>7</i>
5.4. <i>DESCRIPTION OF TEST SETUP.....</i>	<i>8</i>
6. TEST AND MEASUREMENT EQUIPMENT	10
7. Summary Table	11
8. RF POWER OUTPUT VERIFICATION	12
8.1. <i>GSM/GPRS/EDGE</i>	<i>12</i>
8.1.1. <i>GSM OUTPUT POWER RESULT.....</i>	<i>13</i>
9. PEAK TO AVERAGE RATIO	14
9.1. <i>CONDUCTED PEAK TO AVERAGE RESULT.....</i>	<i>14</i>
9.2. <i>CONDUCTED PEAK TO AVERAGE PLOTS.....</i>	<i>15</i>
10. LIMITS AND CONDUCTED RESULTS.....	16
10.1. <i>OCCUPIED BANDWIDTH.....</i>	<i>16</i>
10.1.1. <i>OCCUPIED BANDWIDTH RESULTS.....</i>	<i>16</i>
10.1.2. <i>OCCUPIED BANDWIDTH PLOTS</i>	<i>17</i>
10.2. <i>BAND EDGE EMISSIONS</i>	<i>19</i>
10.2.1. <i>BAND EDGE PLOTS</i>	<i>20</i>
10.3. <i>OUT OF BAND EMISSIONS.....</i>	<i>22</i>
10.3.1. <i>OUT OF BAND EMISSIONS RESULT</i>	<i>22</i>
10.3.2. <i>OUT OF BAND EMISSIONS PLOTS.....</i>	<i>23</i>
10.1. <i>FREQUENCY STABILITY.....</i>	<i>25</i>
10.1.1. <i>FREQUENCY STABILITY RESULTS.....</i>	<i>26</i>
11. RADIATED TEST RESULTS	28

11.1.	<i>RADIATED POWER (ERP & EIRP)</i>	28
11.1.1.	ERP/EIRP Results.....	28
11.1.2.	ERP/EIRP DATA.....	29
11.2.	<i>FIELD STRENGTH OF SPURIOUS RADIATION</i>	30
11.2.1.	SPURIOUS RADIATION PLOTS.....	31
12.	SETUP PHOTOS	32

1. ATTESTATION OF TEST RESULTS

COMPANY NAME: SAMSUNG ELECTRONICS CO., LTD.
EUT DESCRIPTION: GSM Phone + Bluetooth/BLE and DTS b/g/n
MODEL NUMBER: SM-G361H, SM-G361H/DS
SERIAL NUMBER: R31G401L8VT (RADIATED); R31G401LD7E (CONDUCTED)
DATE TESTED: MAY 11 - MAY 20, 2015

APPLICABLE STANDARDS	
STANDARD	TEST RESULTS
FCC PART 22H, 24E, 27	Pass

UL Korea, Ltd. tested the above equipment in accordance with the requirements set forth in the above standards. All indications of Pass/Fail in this report are opinions expressed by UL Korea, Ltd. based on interpretations and/or observations of test results. Measurement Uncertainties were not taken into account and are published for informational purposes only. The test results show that the equipment tested is capable of demonstrating compliance with the requirements as documented in this report.

Note: The results documented in this report apply only to the tested sample, under the conditions and modes of operation as described herein. This document may not be altered or revised in any way unless done so by UL Korea, Ltd. and all revisions are duly noted in the revisions section. Any alteration of this document not carried out by UL Korea, Ltd. will constitute fraud and shall nullify the document. This report must not be used by the client to claim product certification, approval, or endorsement by IAS, any agency of the Federal Government, or any agency of any government.

Approved & Released For
UL Korea, Ltd. By:

Tested By:



Ji Ho Choi
Suwon Lab Manager
UL Korea, Ltd.

CY Choi
Suwon Lab Engineer
UL Korea, Ltd.

2. TEST METHODOLOGY

The tests documented in this report were performed in accordance with TIA-603-C, FCC CFR 47 Part 22 and FCC CFR Part 24.

3. FACILITIES AND ACCREDITATION

The test sites and measurement facilities used to collect data are located at 218 Maeyeong-ro, Yeongtong-gu, Suwon-si, Gyeonggi-do, 443-823, Korea. Line conducted emissions are measured only at the 218 address. The following table identifies which facilities were utilized for radiated emission measurements documented in this report. Specific facilities are also identified in the test results sections.

218 Maeyeong-ro	
<input checked="" type="checkbox"/>	Chamber 1
<input type="checkbox"/>	Chamber 2

UL Korea, Ltd. is accredited by IAS, Laboratory Code TL-637. The full scope of accreditation can be viewed at <http://www.iasonline.org/PDF/TL/TL-637.pdf>.

4. CALIBRATION AND UNCERTAINTY

4.1. MEASURING INSTRUMENT CALIBRATION

The measuring equipment utilized to perform the tests documented in this report has been calibrated in accordance with the manufacturer's recommendations, and is traceable to recognized national standards.

4.2. SAMPLE CALCULATION

Where relevant, the following sample calculation is provided:

$EIRP = \text{PSA reading with EUT worst orientation (dBm)} + \text{Path loss (dB)} - \text{cable loss (between the SG and substitution antenna)} + \text{Substitution Antenna Factor (dBi)}$

$ERP = \text{PSA reading with EUT worst orientation (dBm)} + \text{Path loss (dB)} - \text{cable loss (between the SG and substitution antenna)}$

(Path loss = Signal generator output – PSA reading with substitution antenna)

4.3. MEASUREMENT UNCERTAINTY

Where relevant, the following measurement uncertainty levels have been estimated for tests performed on the apparatus:

PARAMETER	UNCERTAINTY
Conducted Disturbance, 0.15 to 30 MHz	2.32 dB
Radiated Disturbance, Below 1GHz	4.14 dB
Radiated Disturbance, Above 1 GHz	5.97 dB

Uncertainty figures are valid to a confidence level of 95%.

5. EQUIPMENT UNDER TEST

5.1. DESCRIPTION OF EUT

The EUT is a GSM Phone + Bluetooth/BLE, DTS b/g/n.

SM-G361H and SM-G361H/DS are same hardware but for different number of SIM card slot. SM-G361H has one slot. SM-G361H/DS is dual SIM version.

5.2. MAXIMUM OUTPUT POWER (GSM)

The transmitter has a maximum peak conducted and radiated ERP / EIRP output powers as follows:

FCC Part 22/24						
Band	Frequency Range [MHz]	Modulation Peak	Conducted		Radiated	
			Avg [dBm]	Avg [mW]	Avg [dBm]	Avg [mW]
GSM850	824~849	GMSK	32.66	1845.02		
		GPRS	32.68	1853.53	30.00	1000.00
		EGPRS	RX Only			
GSM1900	1850~1910	GMSK	29.22	835.60		
		GPRS	29.24	839.46	31.58	1438.80
		EGPRS	RX Only			

5.3. DESCRIPTION OF AVAILABLE ANTENNAS

The radio utilizes a FPCB antenna for the [List the bands supported] with a maximum peak gain as follow:

Frequency (MHz)	Peak Gain (dBi)
GSM 850 824 ~ 849 MHz	-2.15
GSM 1900 1850 ~ 1910 MHz	0.87

5.4. DESCRIPTION OF TEST SETUP

SUPPORT EQUIPMENT

Support Equipment List				
Description	Manufacturer	Model	Serial Number	FCC ID
Charger	SAMSUNG	ETA0U10EWE	N/A	N/A
Data Cable	SAMSUNG	ECB-DU28WE	N/A	N/A
Earphone	SAMSUNG	EHS61ASFWE	N/A	N/A

I/O CABLES

I/O Cable List						
Cable No	Port	# of identical ports	Connector Type	Cable Type	Cable Length (m)	Remarks
1	DC Power	1	Mini-USB	Shielded	0.8m	N/A
2	Audio	1	Mini-Jack	Unshielded	1.0m	N/A

TEST SETUP

The EUT is continuously communicated to the call box during the tests.

SETUP DIAGRAM FOR TESTS (CONDUCTED TEST SETUP)

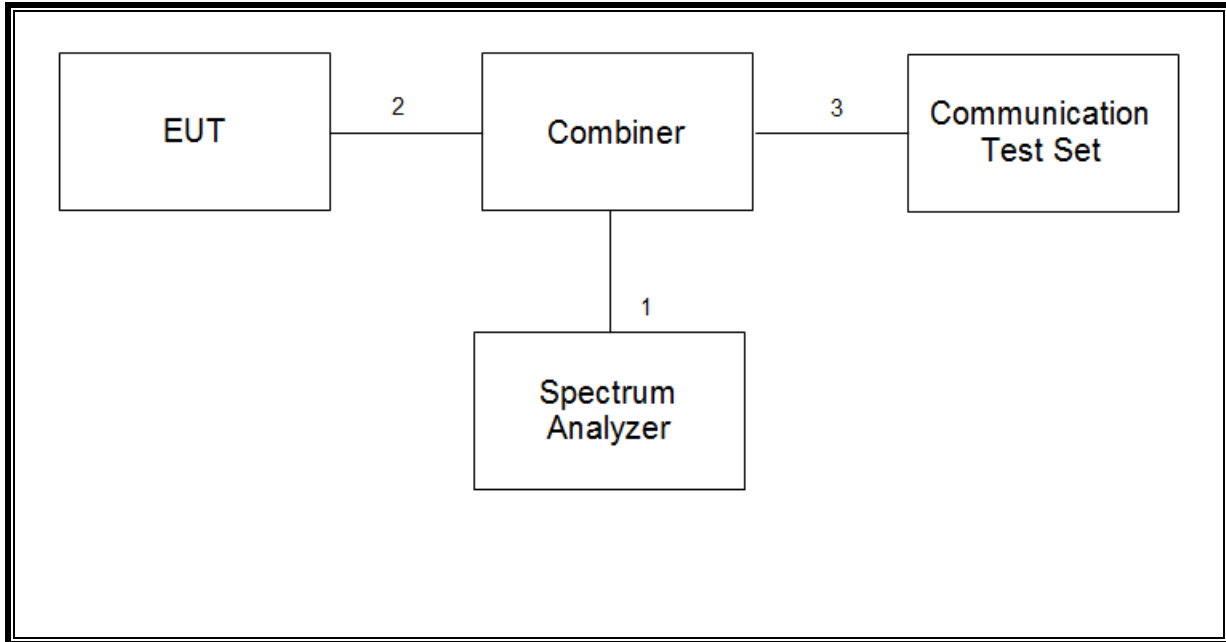

SETUP DIAGRAM FOR TESTS (RADIATED TEST SETUP)

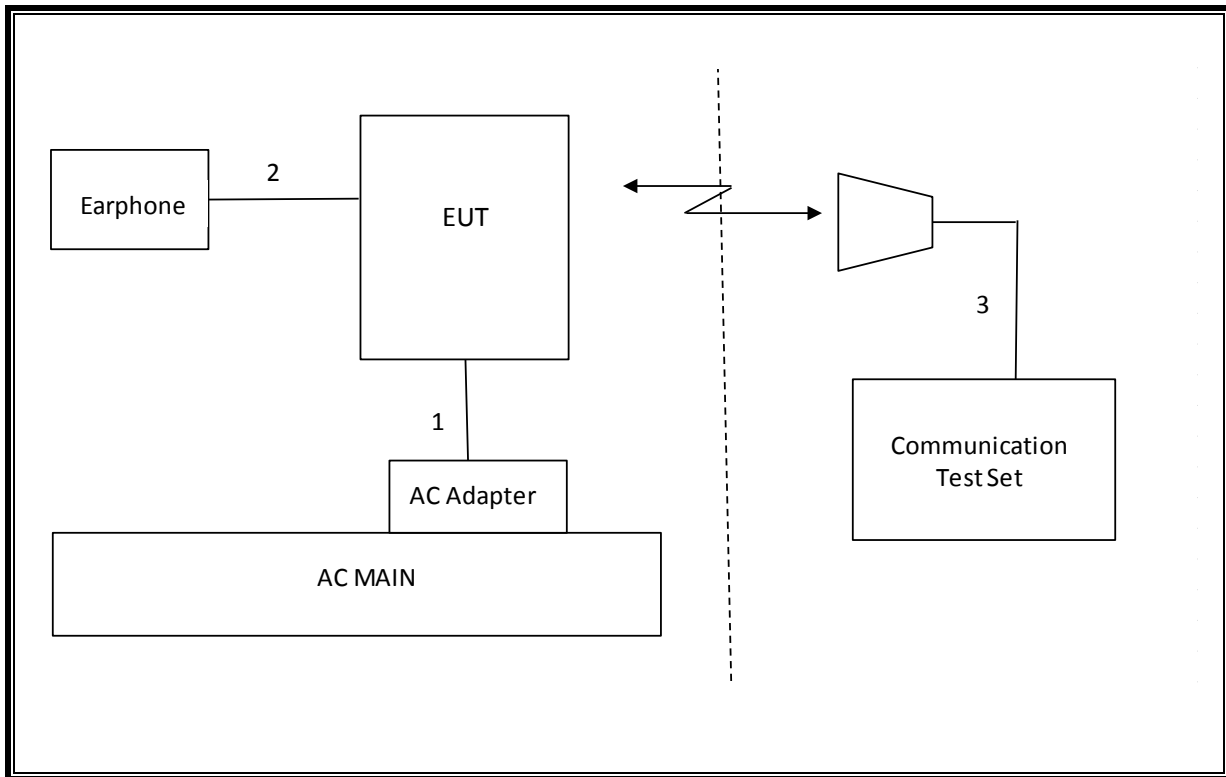

6. TEST AND MEASUREMENT EQUIPMENT

The following test and measurement equipment was utilized for the tests documented in this report:

Test Equipment List				
Description	Manufacturer	Model	S/N	Cal Due
Antenna, Tuned Dipole 400~1000 MHz	ETS	3121D DB4	00164753	07-29-15
Antenna, Bilog, 30MHz-1GHz	SCHWARZBECK	VULB9163	950	11-17-15
Antenna, Horn, 18 GHz	ETS	3115	00167211	09-20-15
Antenna, Horn, 40 GHz	ETS	3116C	00166255	09-23-15
Antenna, Horn, 40 GHz	ETS	3116C-PA	00168841	09-29-15
Preamplifier, 1000 MHz	Sonoma	310N	341282	11-17-15
Preamplifier, 18 GHz	Miteq	AFS42-00101800-25-S-42	1876511	11-18-15
Spectrum Analyzer, 44 GHz	Agilent / HP	N9030A	MY54170614	09-23-15
Communications Test Set	R&S	CMW500	150312	08-13-15
Average Power Sensor	R&S	NRZ-Z91	102681	11-17-15
Average Power Sensor	Agilent / HP	U2000	MY54270007	09-23-15
EMI Test Receive, 40 GHz	R&S	ESU40	100439	11-17-15
EMI Test Receive, 3 GHz	R&S	ESR3	101832	11-17-15
Attenuator / Switch driver	HP	11713A	3748A04272	N/A
Low Pass Filter 3GHz	Micro-Tronics	LPS17541	009	11-17-15
High Pass Filter 5GHz	Micro-Tronics	HPS17542	009	11-17-15
High Pass Filter 6GHz	Micro-Tronics	HPM17543	010	11-17-15
Combiner	WEINSCHEL	1575	2153	11-17-15
Temperature Chamber	ESPEC	SH-642	93001109	11-13-15
DC Power Supply	Agilent / HP	E3640A	MY54226395	09-23-15

7. Summary Table

FCC Part Section	Test Description	Test Limit	Test Condition	Test Result	Note
2.1049	Occupied Band width (99%)	N/A	Conducted	Pass	244.24 kHz
22.917(a) 24.238(a)	Band Edge / Conducted Spurious Emission	-13dBm		Pass	-22.24 dBm
2.1046	Conducted output power	N/A		Pass	32.68 dBm
22.355 24.235	Frequency Stability	2.5PPM		Pass	0.081PPM
22.913(a)(2)	Effective Radiated Power	38 dBm	Radiated	Pass	30.00 dBm
24.232(c)	Equivalent Isotropic Radiated Power	33 dBm		Pass	31.58 dBm
22.917(a) 24.238(a)	Radiated Spurious Emission	-13dBm		Pass	-39.7 dBm

FCC Rule Part	Frequency Range [MHz]	Output Power [W]	Frequency Tolerance	Emission Designator	Emission Bandwidth [MHz]	Communication Type
GSM						
22H	824.2 - 848.8	1.000	2.5 ppm	244KGXW	244 kHz	GSM850
24E	1850.2 - 1909.8	1.439	2.5 ppm	244KGXW	244 kHz	GSM1900

8. RF POWER OUTPUT VERIFICATION

8.1. GSM/GPRS/EDGE

Function: Menu select > GSM Mobile Station > GSM 850/900/1800/1900
Press Connection control to choose the different menus
Press RESET > choose all to reset all settings
Connection Press Signal Off to turn off the signal and change settings
Network Support > GSM+GPRS or GSM+EGPRS
Main Service > Packet Data
Service selection > Test Mode A – Auto Slot Config. off
MS Signal Press Slot Config bottom on the right twice to select and change the number of time slots and power setting
 > Slot configuration > Uplink/Gamma
 > 33 dBm for GPRS 850/900
 > 30 dBm for GPRS1800/1900
BS Signal Enter the same channel number for TCH channel (test channel) and BCCH channel
Frequency Offset > + 0 Hz
Mode > BCCH and TCH
BCCH Level > -85 dBm (May need to adjust if link is not stable)
BCCH Channel > choose desire test channel [Enter the same channel number for TCH channel (test channel) and BCCH channel]
Channel Type > Off
P0> 4 dB
Slot Config > Unchanged (if already set under MS Signal)
TCH > choose desired test channel
Hopping > Off
Main Timeslot > 3 (Default)
Network Coding Scheme > CS4 (GPRS) and MCS5 ~ MCS9 (EGPRS)
Bit Stream > 2E9-1PSR Bit Pattern
AF/RF Enter appropriate offsets for Ext. Att. Output and Ext. Att. Input
Connection Press Signal On to turn on the signal and change settings

8.1.1. GSM OUTPUT POWER RESULT

GSM850 Measured Results

Band	Mode	Coding Scheme	Time Slots	Ch No.	Freq. [MHz]	Max. Power		
						Burst Pwr [dBm]	Frame Pwr [dBm]	
850	GSM (Voice)	CS1	1	128	824.2	32.65	23.62	
				190	836.6	32.56	23.53	
				251	848.8	32.66	23.63	
	GPRS (GMSK)	CS1	1	1	128	824.2	32.68	23.65
					190	836.6	32.57	23.54
					251	848.8	32.68	23.65
			2	1	128	824.2	30.08	24.06
					190	836.6	30.13	24.10
					251	848.8	30.19	24.17
			3	1	128	824.2	28.09	23.83
					190	836.6	28.11	23.85
					251	848.8	28.14	23.88
			4	1	128	824.2	26.06	23.05
					190	836.6	26.05	23.04
					251	848.8	26.08	23.07

GSM1900 Measured Results

Band	Mode	Coding Scheme	Time Slots	Ch No.	Freq. [MHz]	Max. Power		
						Burst Pwr [dBm]	Frame Pwr [dBm]	
1900	GSM (Voice)	CS1	1	512	1850.2	29.22	20.19	
				661	1880.0	29.14	20.10	
				810	1909.8	29.11	20.08	
	GPRS (GMSK)	CS1	1	1	512	1850.2	29.24	20.21
					661	1880.0	29.15	20.12
					810	1909.8	29.13	20.10
			2	1	512	1850.2	28.13	22.11
					661	1880.0	27.98	21.96
					810	1909.8	27.72	21.70
			3	1	512	1850.2	26.43	22.17
					661	1880.0	26.22	21.96
					810	1909.8	25.93	21.67
			4	1	512	1850.2	24.46	21.45
					661	1880.0	24.23	21.22
					810	1909.8	23.88	20.87

9. PEAK TO AVERAGE RATIO

Test Procedure

Per KDB 971168 D01 Power Meas License Digital Systems v02r02;

The transmitter output was connected to a CMW500 Test Set and configured to operate at maximum power. The PAR were measured on the Spectrum Analyzer.

Test Spec

In addition, when the transmitter power is measured in terms of average value, the peak-to-average ratio of the power shall not exceed 13 dB.

9.1. CONDUCTED PEAK TO AVERAGE RESULT

GSM

Band	Channel	f [MHz]	Mode	Ratio [dB]	Limit [dB]
GSM850	190	836.6	GPRS	2.64	13.00
GSM1900	661	1880.0	GPRS	2.62	

9.2. CONDUCTED PEAK TO AVERAGE PLOTS

GSM

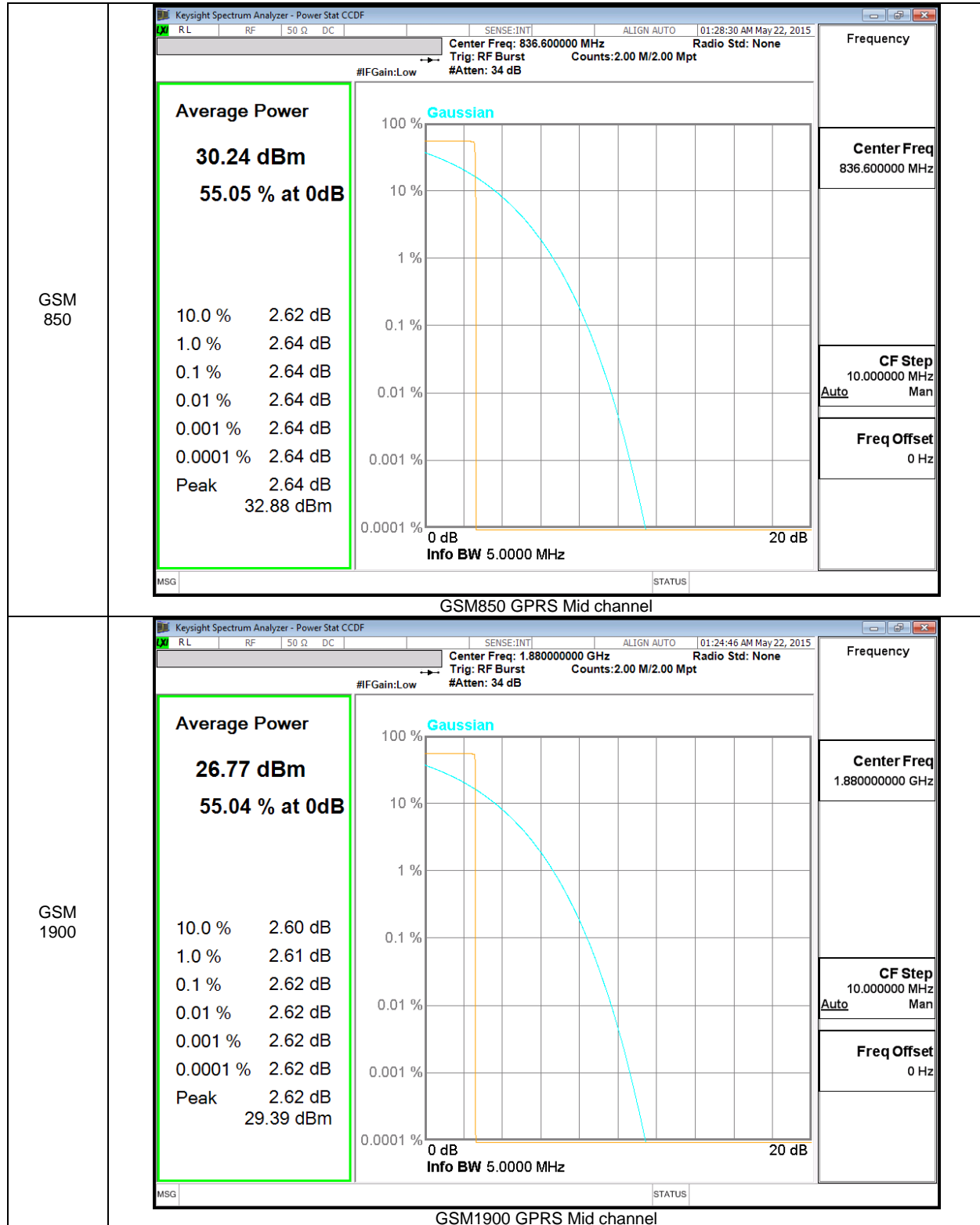

10. LIMITS AND CONDUCTED RESULTS

10.1. OCCUPIED BANDWIDTH

RULE PART(S)

FCC: §2.1049

LIMITS

For reporting purposes only

TEST PROCEDURE

The transmitter output was connected to a calibrated coaxial cable and coupler, the other end of which was connected to a spectrum analyzer. The occupied bandwidth was measured with the spectrum analyzer at the low, middle and high channel in each band. The -26dB bandwidth was also measured and recorded.

(KDB 971168 D01 Power Meas License Digital Systems v02r02)

10.1.1. OCCUPIED BANDWIDTH RESULTS

GSM

Band	Mode	Channel	f [MHz]	99% BW [KHz]	26dB BW [KHz]
GSM850	GPRS	128	824.2	243.62	320.80
		190	836.6	242.80	314.80
		251	848.8	240.71	317.00
GSM1900	GPRS	512	1850.2	243.35	321.40
		661	1880.0	244.24	318.90
		810	1909.8	242.72	314.60

10.1.2. OCCUPIED BANDWIDTH PLOTS

GSM 850

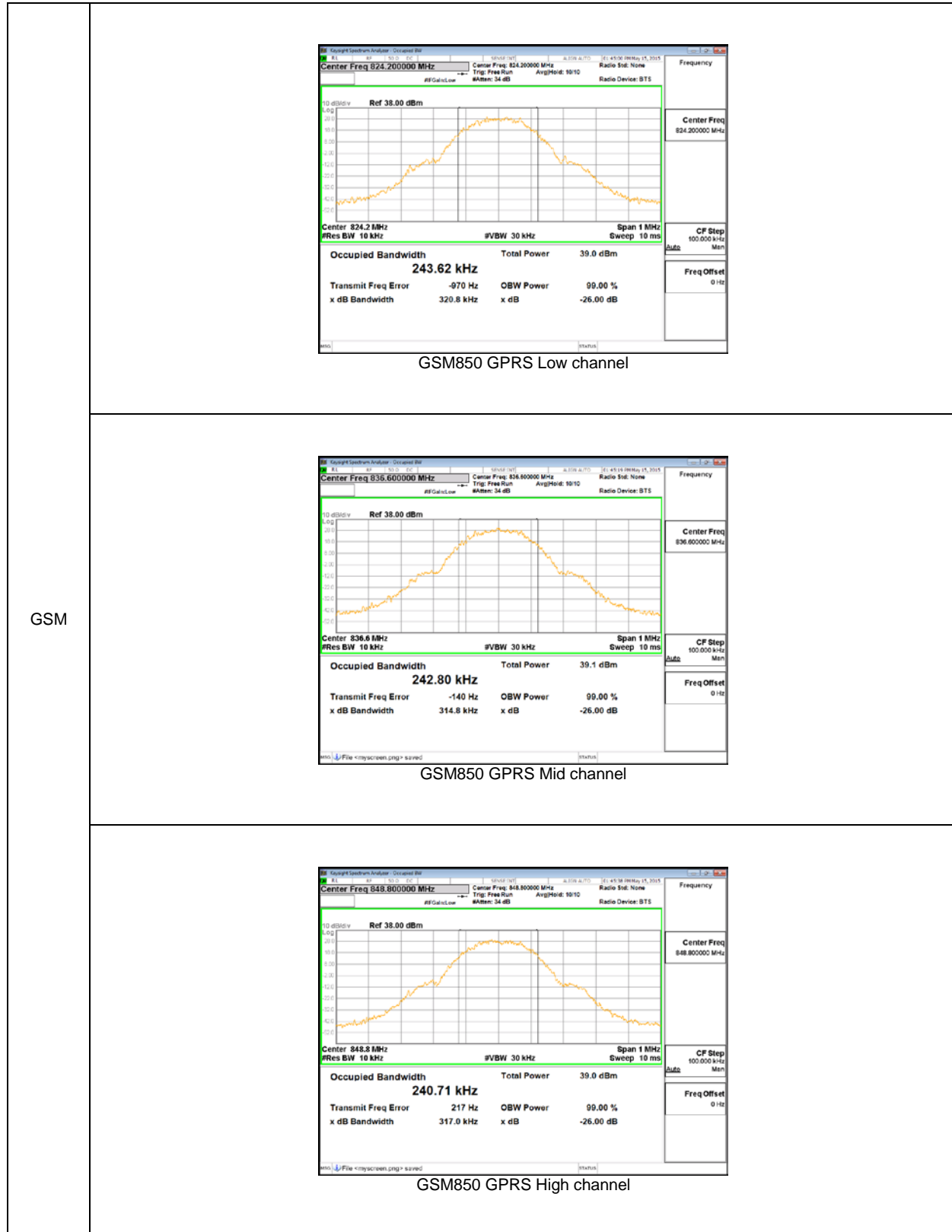

GSM 1900

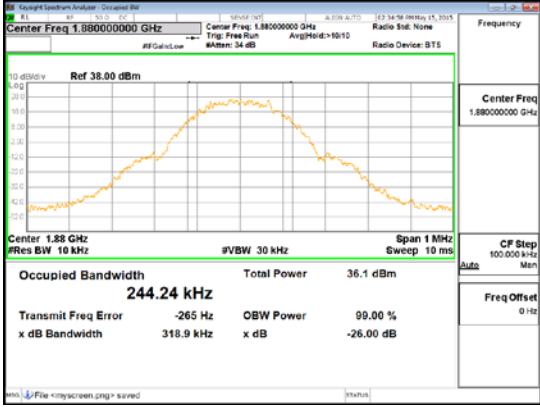
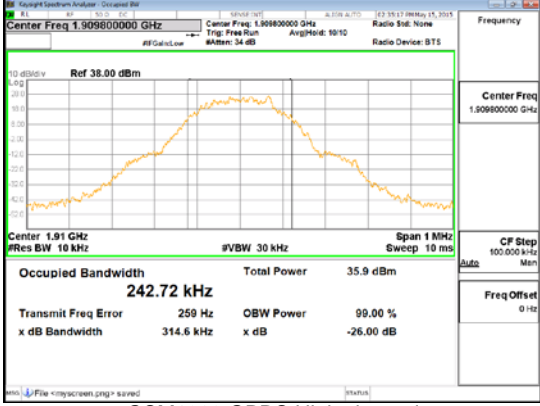
GSM	 <p>GSM1900 GPRS Low channel</p>
	 <p>GSM1900 GPRS Mid channel</p>
	 <p>GSM1900 GPRS High channel</p>

10.2. BAND EDGE EMISSIONS

RULE PART(S)

FCC: §22.359, §24.238, §27.53 (g)

LIMITS

The power of any emission outside of the authorized operating frequency ranges must be attenuated below the transmitting power (P) by a factor of at least $43 + 10 \log (P)$ dB.

TEST PROCEDURE

Per KDB 971168 D01 Power Meas License Digital Systems v02r02

The transmitter output was connected to a CMW500 Test Set and configured to operate at maximum power. The band edge emissions were measured at the required operating frequencies in each band on the Spectrum Analyzer.

RESULTS

GSM

Band	Mode	Side	f [MHz]	Level [dBm]	Limit [dBm]
GSM850	GPRS	Lower	823.9959	-23.431	-13.000
		Upper	849.0236	-26.277	
GSM1900	GPRS	Lower	1849.9901	-25.562	
		Upper	1910.0185	-26.030	

10.2.1. BAND EDGE PLOTS

GSM

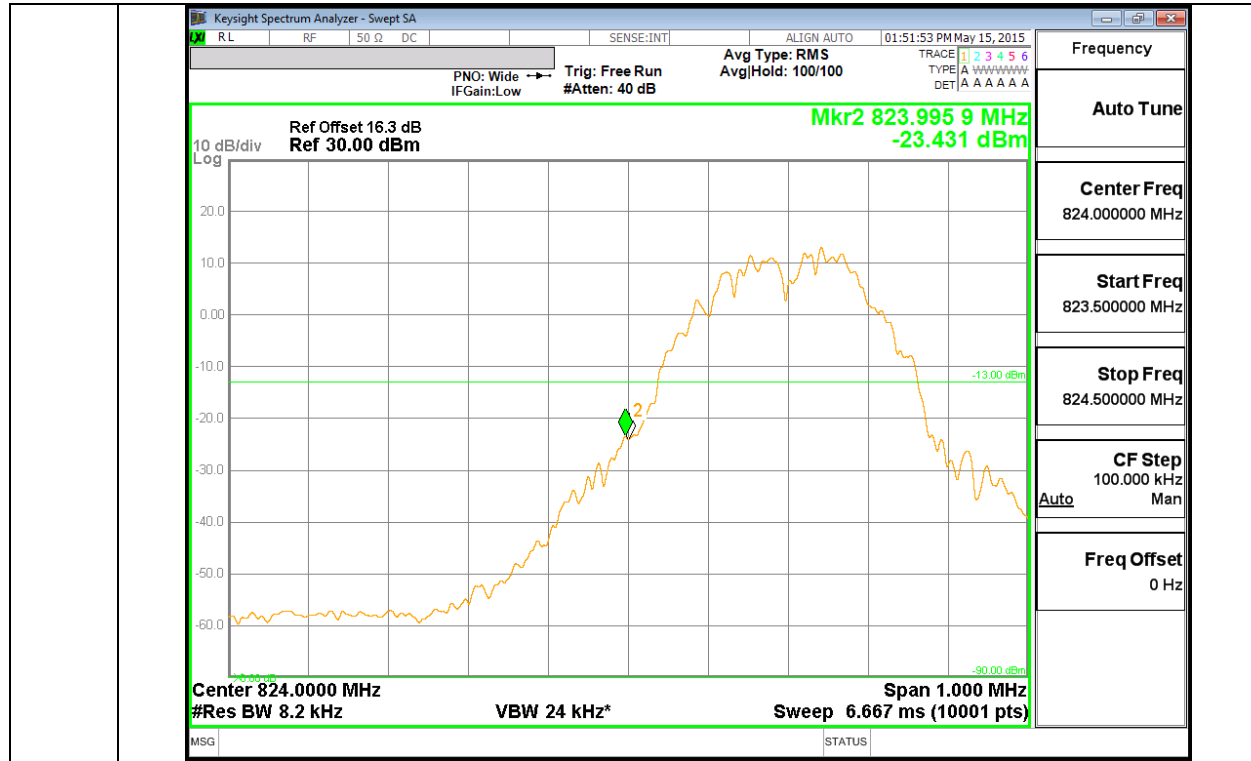

GSM850 GPRS Low channel

GSM
850

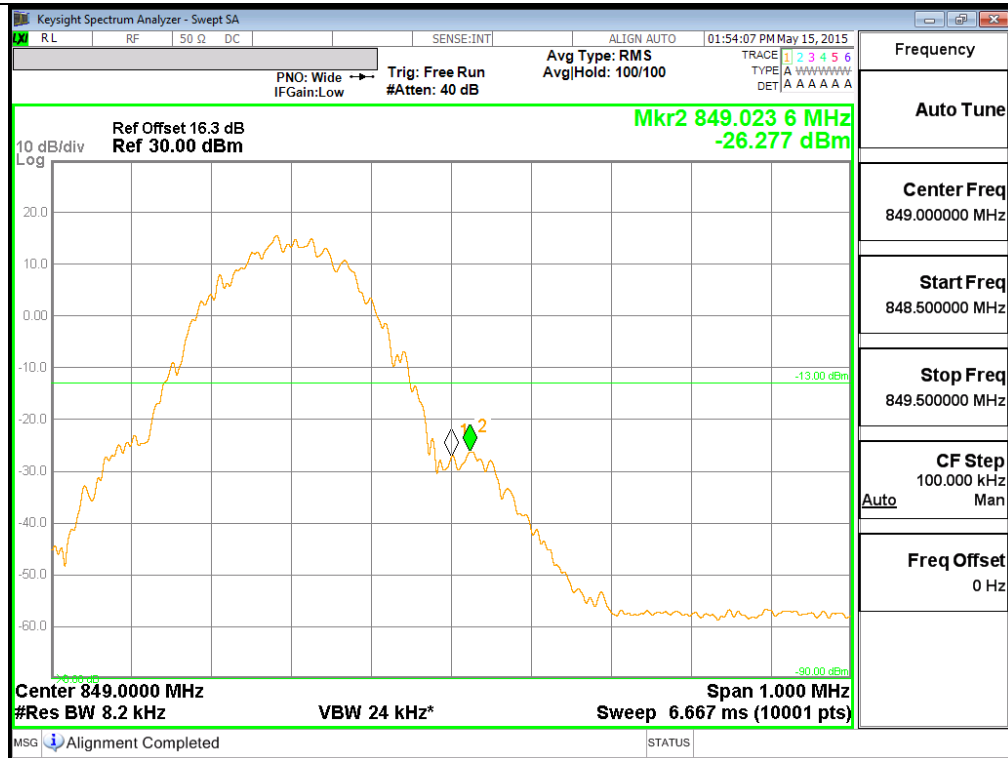

GSM850 GPRS High channel

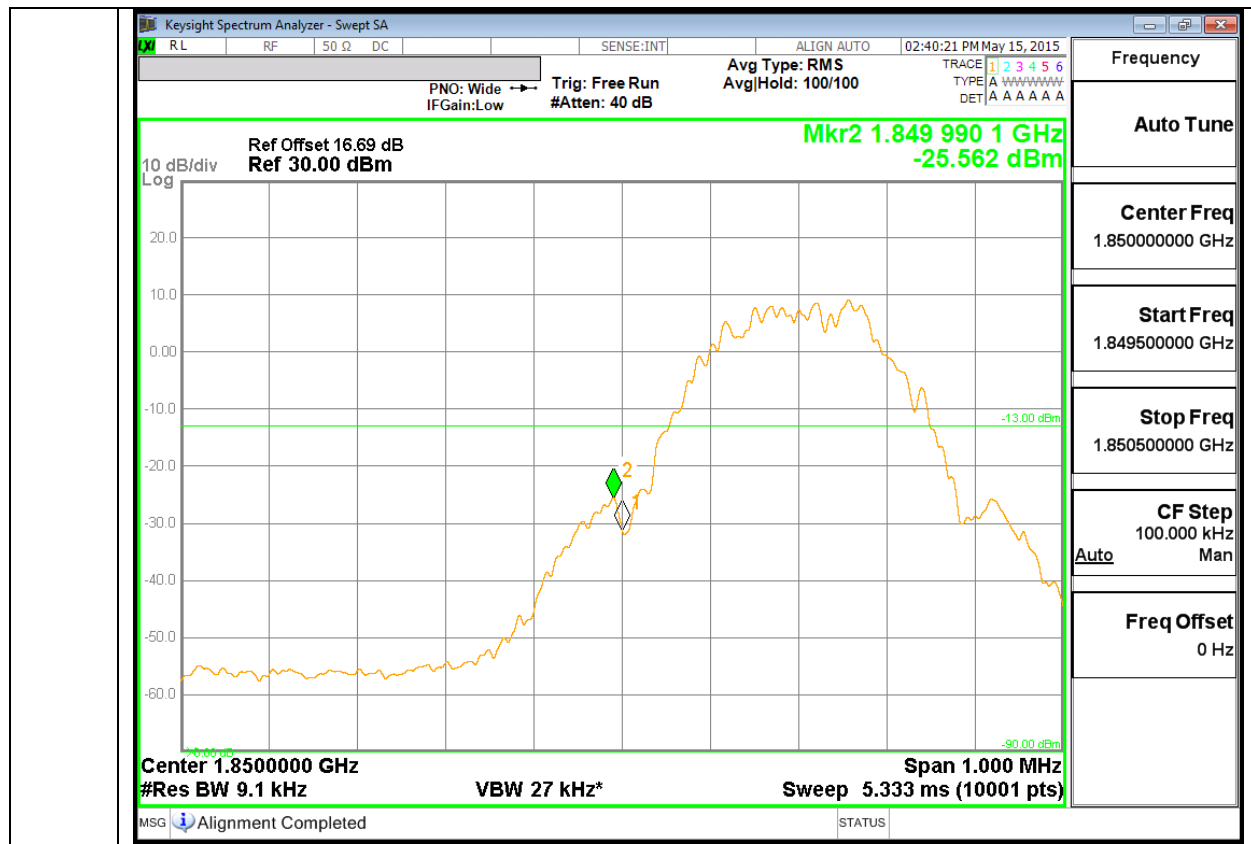

GSM
1900

GSM1900 GPRS Low channel

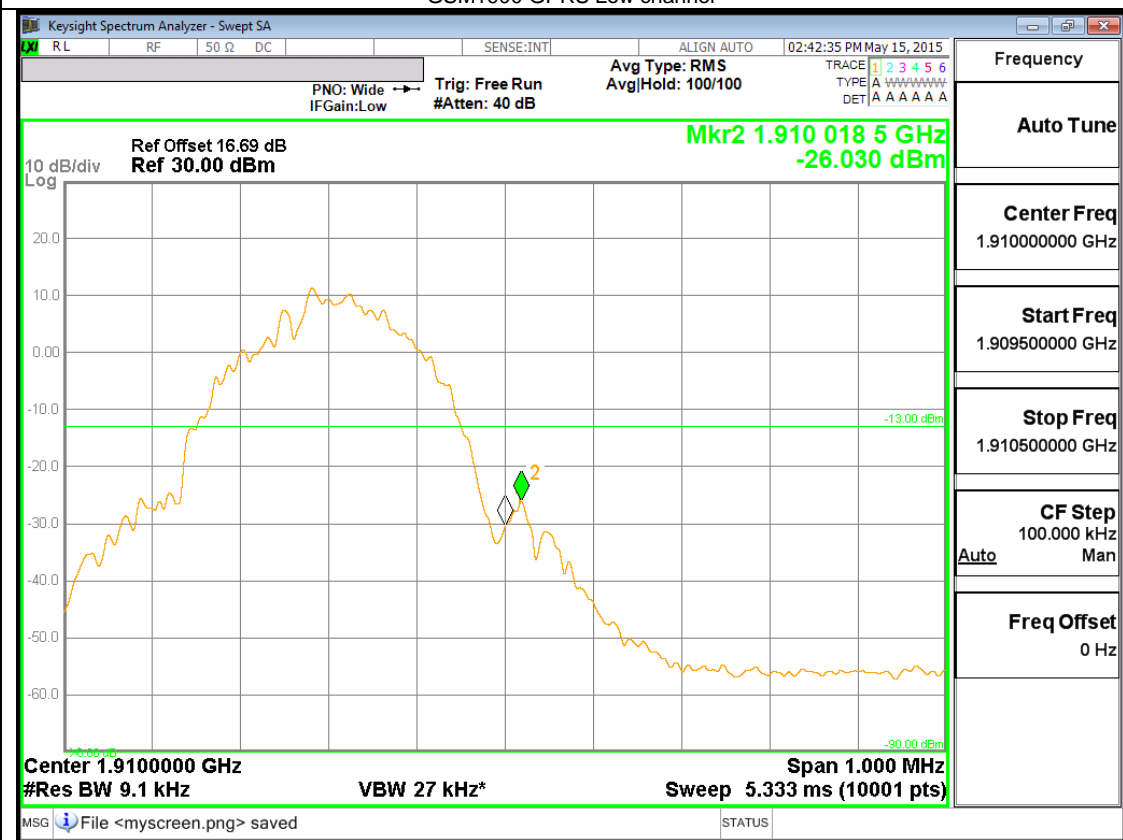

GSM1900 GPRS High channel

10.3. OUT OF BAND EMISSIONS

RULE PART(S)

FCC: §2.1051, §22.901, §22.917, §24.238, §27.53 (g)

LIMITS

The power of any emission outside of the authorized operating frequency ranges must be attenuated below the transmitting power (P) by a factor of at least $43 + 10 \log (P)$ dB.

TEST PROCEDURE

Per KDB 971168 D01 Power Meas License Digital Systems v02r02

The RF output of the transmitter was connected to a spectrum analyzer through a calibrated coaxial cable. Sufficient scans were taken to show the out-of-band Emissions, if any, up to 10th harmonic. Multiple sweeps were recorded in maximum hold mode using a peak detector to ensure that the worst-case emissions were caught.

RESULTS

10.3.1. OUT OF BAND EMISSIONS RESULT

GSM

Band	Mode	f [MHz]	Spurious [dBm]	Limit [dBm]	Margin [dB]
GSM850	GPRS	824.2	-23.08	-13.00	10.08
		836.6	-22.64		9.64
		848.8	-22.74		9.74
GSM1900	GPRS	1850.2	-22.25		9.25
		1880.0	-22.24		9.24
		1909.8	-22.29		9.29

10.3.2. OUT OF BAND EMISSIONS PLOTS

GSM 850

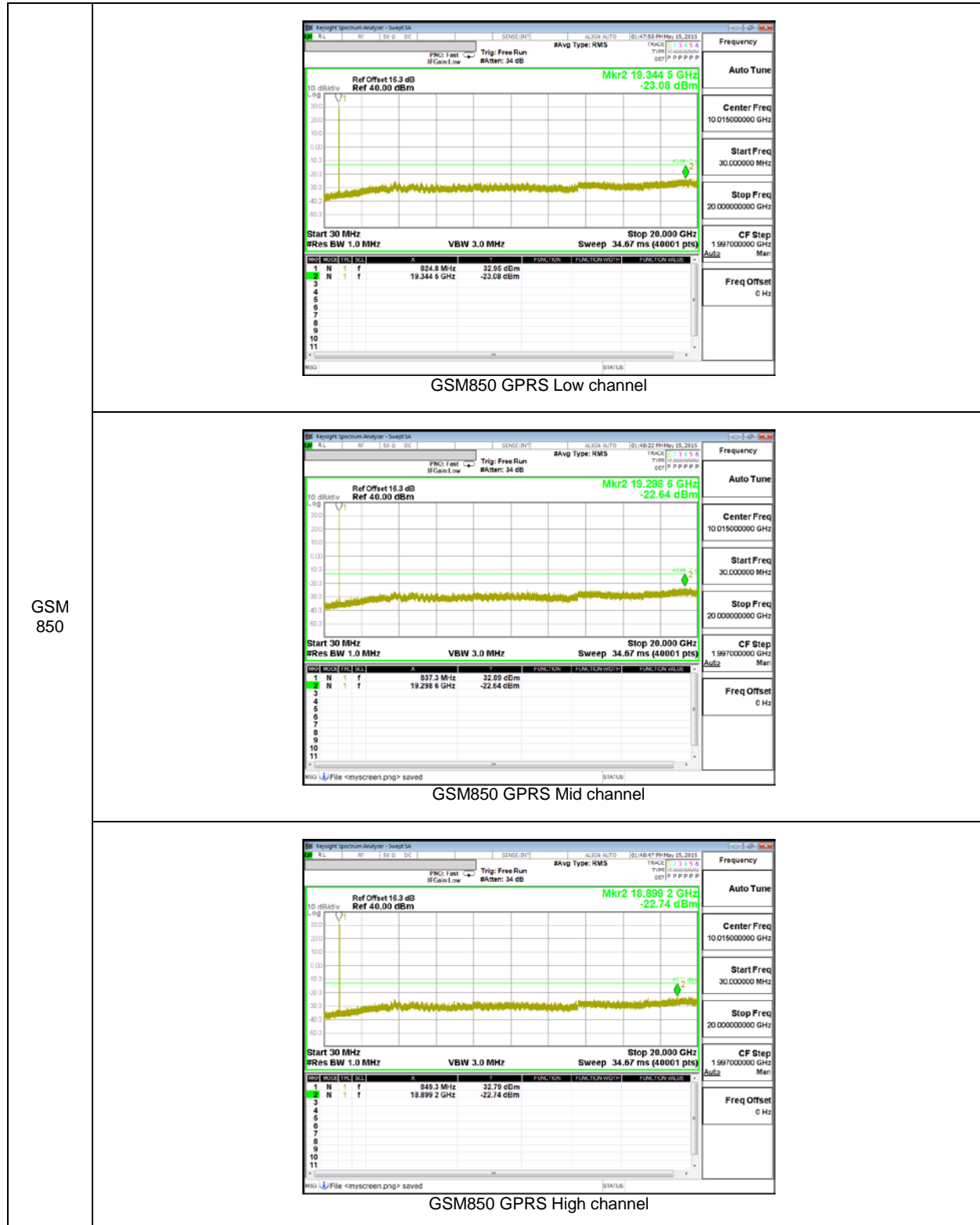

GSM 1900

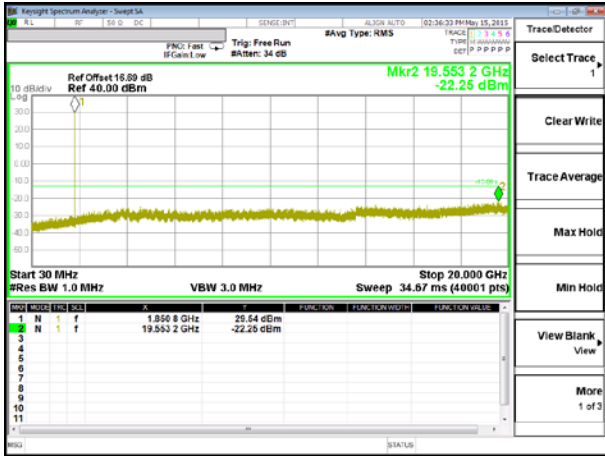
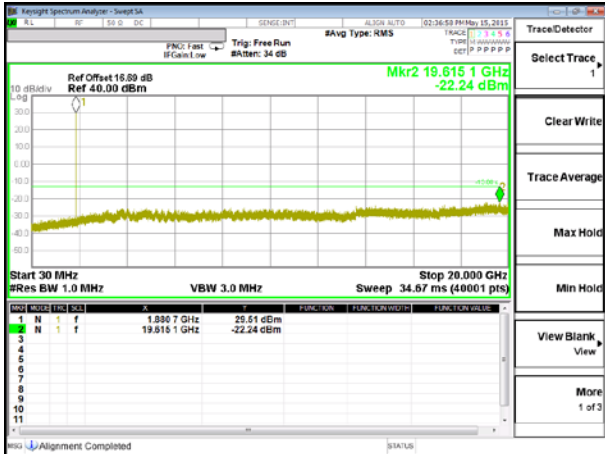
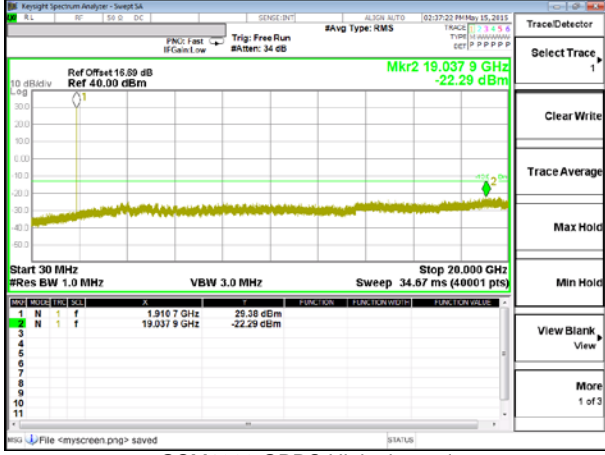
	 <p>GSM1900 GPRS Low channel</p>
<p>GSM 1900</p>	 <p>GSM1900 GPRS Mid channel</p>
	 <p>GSM1900 GPRS High channel</p>

10.1. FREQUENCY STABILITY

RULE PART(S)

FCC: §2.1055, §22.355, §24.235

LIMITS

§22.355 - The carrier frequency shall not depart from the reference frequency in excess of ± 2.5 ppm for mobile stations.

§24.235 - The frequency stability shall be sufficient to ensure that the fundamental emission stays within the authorized frequency block.

TEST PROCEDURE

Per KDB 971168 D01 Power Meas License Digital Systems v02r02

RESULTS

See the following pages.

10.1.1. FREQUENCY STABILITY RESULTS

GSM 850, Channel 190, Frequency 836.6 MHz

Reference Frequency: Cell Mid Channel 836.6 MHz @ 20°C				
Limit: ± 2.5 ppm = 2091.500 Hz				
Power Supply (Vdc)	Environment Temperature (*C)	Frequency Deviation Measured with Time Elapse		
		(MHz)	Delta (ppm)	Limit (ppm)
3.80	50	836.59995223	0.029	2.5
3.80	40	836.59995119	0.030	2.5
3.80	30	836.59993824	0.045	2.5
3.80	20	836.59997617	0	2.5
3.80	10	836.59998156	-0.006	2.5
3.80	0	836.60004070	-0.077	2.5
3.80	-10	836.60004226	-0.079	2.5
3.80	-20	836.60004384	-0.081	2.5
3.80	-30	836.60004155	-0.078	2.5

Reference Frequency: WCDMA Band5 Mid Channel 836.6 MHz @ 20°C				
Limit: ± 2.5 ppm = 2091.500 Hz				
Power Supply (Vdc)	Environment Temperature (*C)	Frequency Deviation Measured with Time Elapse		
		(MHz)	Delta (ppm)	Limit (ppm)
3.80	20	836.59997617	0	2.5
4.20	20	836.59996652	0.012	2.5
3.40	20	836.59996578	0.012	2.5

GSM 1900, Channel 661, Frequency 1880.0 MHz

Reference Frequency: PCS Mid Channel 1880 MHz @ 20°C				
Limit: ± 2.5 ppm = 4700.000 Hz				
Power Supply (Vdc)	Environment Temperature (*C)	Frequency Deviation Measured with Time Elapse		
		(MHz)	Delta (ppm)	Limit (ppm)
3.80	50	1879.99993921	0.007	2.5
3.80	40	1879.99993337	0.010	2.5
3.80	30	1879.99994660	0.003	2.5
3.80	20	1879.99995180	0	2.5
3.80	10	1880.00002776	-0.040	2.5
3.80	0	1880.00003681	-0.045	2.5
3.80	-10	1880.00002015	-0.036	2.5
3.80	-20	1880.00004770	-0.051	2.5
3.80	-30	1879.99998676	-0.019	2.5

Reference Frequency: WCDMA Band2 Mid Channel 1880 MHz @ 20°C				
Limit: ± 2.5 ppm = 4700.000 Hz				
Power Supply (Vdc)	Environment Temperature (*C)	Frequency Deviation Measured with Time Elapse		
		(MHz)	Delta (ppm)	Limit (ppm)
3.80	20	1879.99995180	0	2.5
4.20	20	1879.99994079	0.006	2.5
3.40	20	1879.99995665	-0.003	2.5

11. RADIATED TEST RESULTS

11.1. RADIATED POWER (ERP & EIRP)

RULE PART(S)

FCC: §2.1046, §22.913, §24.232

LIMITS

22.913(a) - The ERP of mobile transmitters and auxiliary test transmitters must not exceed 7 Watts.

24.232(c) - Mobile/portable stations are limited to 2 watts e.i.r.p. peak power and the equipment must employ means to limit the power to the minimum necessary for successful communications.

In addition, when the transmitter power is measured in terms of average value, the peak-to-average ratio of the power shall not exceed 13dB.

TEST PROCEDURE

ANSI / TIA / EIA 603C Clause 2.2.17; MXA setting reference to 971168 D01 v02r02

For peak power measurement with a MXA:

a) Set the RBW \geq OBW; b) Set VBW $\geq 3 \times$ RBW; c) Set span $\geq 2 \times$ RBW; d) Sweep time = auto couple; e) Detector = peak; f) Ensure that the number of measurement points \geq span/RBW; g) Trace mode = max hold;

For average power measurement with a MXA:

a) Set span to at least 1.5 times the OBW; b) Set RBW = 1-5% of the OBW, not to exceed 1 MHz; c) Set VBW $\geq 3 \times$ RBW; d) Set number of points in sweep $\geq 2 \times$ span / RBW; e) Sweep time = auto-couple; f) Detector = RMS (power averaging); g) Use free run trigger If burst duty cycle ≥ 98 ; h) Use trigger to capture bursts If burst duty cycle < 98 ; i) Trace average at least 100 traces in power averaging (i.e., RMS) mode. j) Compute the power by integrating the spectrum across the OBW of the signal using the instrument's band power measurement function.

TEST RESULTS

11.1.1. ERP/EIRP Results

GSM

Band	Mode	Channel	f [MHz]	ERP / EIRP	
				[dBm]	[mW]
GSM850	GPRS	512	824.2	25.19	330.0
		661	836.6	30.00	1000.0
		810	848.8	26.43	439.2
GSM1900	GPRS	512	1850.2	31.58	1438.1
		661	1880.0	31.16	1306.2
		810	1909.8	30.45	1109.9

11.1.2. ERP/EIRP DATA

GSM GSM850 GPRS	High Frequency Substitution Measurement UL Korea, Ltd. Suwon Laboratory Chamber 1																																																																																										
	Company: Samsung Project #: 15K20822 Date: 05-18-15 Test Engineer: Steven Kim Configuration: EUT / adapter / earphone / Z-Position Mode: GPRS 850 MHz <u>Test Equipment:</u> Receiving: VULB9163-750, and 3m Chamber N-type Cable (Setup this one for testing EUT) Substitution: Dipole S/N: 00164753, 3m SMA Cable Warehouse.																																																																																										
	<table border="1"> <thead> <tr> <th>f MHz</th> <th>SG reading (dBm)</th> <th>Ant. Pol. (H/V)</th> <th>Cable Loss (dB)</th> <th>Antenna Gain (dBd)</th> <th>ERP (dBm)</th> <th>Limit (dBm)</th> <th>Margin (dB)</th> <th>Notes</th> </tr> </thead> <tbody> <tr> <td colspan="9">Low Ch</td> </tr> <tr> <td>824.20</td> <td>27.81</td> <td>V</td> <td>1.1</td> <td>-1.6</td> <td>25.19</td> <td>38.5</td> <td>-13.3</td> <td></td> </tr> <tr> <td>824.20</td> <td>25.06</td> <td>H</td> <td>1.1</td> <td>-1.6</td> <td>22.44</td> <td>38.5</td> <td>-16.0</td> <td></td> </tr> <tr> <td colspan="9">Mid Ch</td> </tr> <tr> <td>836.60</td> <td>32.49</td> <td>V</td> <td>1.1</td> <td>-1.4</td> <td>30.00</td> <td>38.5</td> <td>-8.5</td> <td></td> </tr> <tr> <td>836.60</td> <td>24.91</td> <td>H</td> <td>1.1</td> <td>-1.4</td> <td>22.42</td> <td>38.5</td> <td>-16.0</td> <td></td> </tr> <tr> <td colspan="9">High Ch</td> </tr> <tr> <td>848.80</td> <td>28.79</td> <td>V</td> <td>1.1</td> <td>-1.3</td> <td>26.43</td> <td>38.5</td> <td>-12.0</td> <td></td> </tr> <tr> <td>848.80</td> <td>22.56</td> <td>H</td> <td>1.1</td> <td>-1.3</td> <td>20.20</td> <td>38.5</td> <td>-18.3</td> <td></td> </tr> </tbody> </table> <p>Rev. 3.17.11 Note: For Band 13/17 ERP limit is 34.77dBm; For Band 26 limit is 50dBm</p>	f MHz	SG reading (dBm)	Ant. Pol. (H/V)	Cable Loss (dB)	Antenna Gain (dBd)	ERP (dBm)	Limit (dBm)	Margin (dB)	Notes	Low Ch									824.20	27.81	V	1.1	-1.6	25.19	38.5	-13.3		824.20	25.06	H	1.1	-1.6	22.44	38.5	-16.0		Mid Ch									836.60	32.49	V	1.1	-1.4	30.00	38.5	-8.5		836.60	24.91	H	1.1	-1.4	22.42	38.5	-16.0		High Ch									848.80	28.79	V	1.1	-1.3	26.43	38.5	-12.0		848.80	22.56	H	1.1	-1.3	20.20	38.5	-18.3	
f MHz	SG reading (dBm)	Ant. Pol. (H/V)	Cable Loss (dB)	Antenna Gain (dBd)	ERP (dBm)	Limit (dBm)	Margin (dB)	Notes																																																																																			
Low Ch																																																																																											
824.20	27.81	V	1.1	-1.6	25.19	38.5	-13.3																																																																																				
824.20	25.06	H	1.1	-1.6	22.44	38.5	-16.0																																																																																				
Mid Ch																																																																																											
836.60	32.49	V	1.1	-1.4	30.00	38.5	-8.5																																																																																				
836.60	24.91	H	1.1	-1.4	22.42	38.5	-16.0																																																																																				
High Ch																																																																																											
848.80	28.79	V	1.1	-1.3	26.43	38.5	-12.0																																																																																				
848.80	22.56	H	1.1	-1.3	20.20	38.5	-18.3																																																																																				
GSM GSM1900 GPRS	High Frequency Substitution Measurement UL Korea, Ltd. Suwon Laboratory Chamber 1																																																																																										
	Company: Samsung Project #: 15K20822 Date: 05-19-15 Test Engineer: Steven Kim Configuration: EUT ONLY, X Position Mode: GPRS 1900MHz <u>Test Equipment:</u> Receiving: 3117, and Chamber 1 SMA Cables Substitution: 3115 Substitution, 3m SMA Cable Warehouse																																																																																										
	<table border="1"> <thead> <tr> <th>f GHz</th> <th>SG reading (dBm)</th> <th>Ant. Pol. (H/V)</th> <th>Cable Loss (dB)</th> <th>Antenna Gain (dBi)</th> <th>EIRP (dBm)</th> <th>Limit (dBm)</th> <th>Delta (dB)</th> <th>Notes</th> </tr> </thead> <tbody> <tr> <td colspan="9">Low Ch</td> </tr> <tr> <td>1850.20</td> <td>14.8</td> <td>V</td> <td>1.60</td> <td>9.12</td> <td>22.32</td> <td>33.0</td> <td>-10.7</td> <td></td> </tr> <tr> <td>1850.20</td> <td>24.1</td> <td>H</td> <td>1.60</td> <td>9.12</td> <td>31.58</td> <td>33.0</td> <td>-1.4</td> <td></td> </tr> <tr> <td colspan="9">Mid Ch</td> </tr> <tr> <td>1880.00</td> <td>16.0</td> <td>V</td> <td>1.62</td> <td>8.98</td> <td>23.35</td> <td>33.0</td> <td>-9.7</td> <td></td> </tr> <tr> <td>1880.00</td> <td>23.8</td> <td>H</td> <td>1.62</td> <td>8.98</td> <td>31.16</td> <td>33.0</td> <td>-1.8</td> <td></td> </tr> <tr> <td colspan="9">High Ch</td> </tr> <tr> <td>1909.80</td> <td>20.7</td> <td>V</td> <td>1.63</td> <td>8.83</td> <td>27.87</td> <td>33.0</td> <td>-5.1</td> <td></td> </tr> <tr> <td>1909.80</td> <td>23.3</td> <td>H</td> <td>1.63</td> <td>8.83</td> <td>30.45</td> <td>33.0</td> <td>-2.5</td> <td></td> </tr> </tbody> </table> <p>Rev. 3.17.11</p>	f GHz	SG reading (dBm)	Ant. Pol. (H/V)	Cable Loss (dB)	Antenna Gain (dBi)	EIRP (dBm)	Limit (dBm)	Delta (dB)	Notes	Low Ch									1850.20	14.8	V	1.60	9.12	22.32	33.0	-10.7		1850.20	24.1	H	1.60	9.12	31.58	33.0	-1.4		Mid Ch									1880.00	16.0	V	1.62	8.98	23.35	33.0	-9.7		1880.00	23.8	H	1.62	8.98	31.16	33.0	-1.8		High Ch									1909.80	20.7	V	1.63	8.83	27.87	33.0	-5.1		1909.80	23.3	H	1.63	8.83	30.45	33.0	-2.5	
f GHz	SG reading (dBm)	Ant. Pol. (H/V)	Cable Loss (dB)	Antenna Gain (dBi)	EIRP (dBm)	Limit (dBm)	Delta (dB)	Notes																																																																																			
Low Ch																																																																																											
1850.20	14.8	V	1.60	9.12	22.32	33.0	-10.7																																																																																				
1850.20	24.1	H	1.60	9.12	31.58	33.0	-1.4																																																																																				
Mid Ch																																																																																											
1880.00	16.0	V	1.62	8.98	23.35	33.0	-9.7																																																																																				
1880.00	23.8	H	1.62	8.98	31.16	33.0	-1.8																																																																																				
High Ch																																																																																											
1909.80	20.7	V	1.63	8.83	27.87	33.0	-5.1																																																																																				
1909.80	23.3	H	1.63	8.83	30.45	33.0	-2.5																																																																																				

11.2. FIELD STRENGTH OF SPURIOUS RADIATION

RULE PART(S)

FCC: §2.1053, §22.917, §24.238

LIMIT

Part 22.917(a) & Part 24.238(a) The power of any emission outside of the authorized operating frequency ranges must be attenuated below the transmitting power (P) by a factor of at least $43 + 10 \log (P)$ dB.

TEST PROCEDURE

For Cellular equipment - Compliance with these rules is based on the use of measurement instrumentation employing a resolution bandwidth of 100 kHz or greater. In the 1 MHz bands immediately outside and adjacent to the frequency block a resolution bandwidth of at least one percent of the emission bandwidth of the fundamental emission of the transmitter may be employed. A narrower resolution bandwidth is permitted in all cases to improve measurement accuracy provided the measured power is integrated over the full required measurement bandwidth (i.e. 100 kHz or 1 percent of emission bandwidth, as specified). The emission bandwidth is defined as the width of the signal between two points, one below the carrier center frequency and one above the carrier center frequency, outside of which all emissions are attenuated at least 26 dB below the transmitter power.

For PCS equipment - Compliance with these rules is based on the use of measurement instrumentation employing a resolution bandwidth of 1 MHz or greater. However, in the 1 MHz bands immediately outside and adjacent to the frequency block a resolution bandwidth of at least one percent of the emission bandwidth of the fundamental emission of the transmitter may be employed. A narrower resolution bandwidth is permitted in all cases to improve measurement accuracy provided the measured power is integrated over the full required measurement bandwidth (i.e. 1 MHz or 1 percent of emission bandwidth, as specified). The emission bandwidth is defined as the width of the signal between two points, one below the carrier center frequency and one above the carrier center frequency, outside of which all emissions are attenuated at least 26 dB below the transmitter power.

RESULTS

11.2.1. SPURIOUS RADIATION PLOTS

		UL Korea, Ltd Suwon Laboratory Above 1GHz High Frequency Substitution Measurement										
GSM GSM850 GPRS	Company:	Samsung										
	Project #:	15K20822										
	Date:	05-19-15										
	Test Engineer:	Steven Kim										
	Configuration:	EUT / AC Adapter / Earphone, Z Position										
	Mode:	GPRS 850 MHz										
			Chamber	Pre-amplifier	Filter	Limit						
			Chamber 1	AFS42	Filter 1	Part 22						
			f GHz	SG reading (dBm)	Ant. Pol. (H/V)	Distance (m)	Preamp (dB)	Filter (dB)	EIRP (dBm)	Limit (dBm)	Delta (dB)	Notes
			Low Ch, 824.2MHz									
		1.6484	-1.3	V	3.0	40.2	1.0	-40.5	-13.0	-27.5		
		2.4726	-5.4	V	3.0	40.1	1.0	-44.5	-13.0	-31.5		
		3.2968	-16.2	V	3.0	39.6	1.0	-54.8	-13.0	-41.8		
		1.6484	-2.3	H	3.0	40.2	1.0	-41.5	-13.0	-28.5		
		2.4726	-7.3	H	3.0	40.1	1.0	-46.4	-13.0	-33.4		
		3.2968	-19.4	H	3.0	39.6	1.0	-58.0	-13.0	-45.0		
		Mid Ch, 836.6MHz										
		1.6730	-3.3	V	3.0	40.2	1.0	-42.4	-13.0	-29.4		
		2.5098	-14.9	V	3.0	40.1	1.0	-53.9	-13.0	-40.9		
		3.3464	-22.4	V	3.0	39.6	1.0	-61.0	-13.0	-48.0		
		1.6730	-2.2	H	3.0	40.2	1.0	-41.4	-13.0	-28.4		
		2.5098	-14.6	H	3.0	40.1	1.0	-53.7	-13.0	-40.7		
		3.3464	-22.6	H	3.0	39.6	1.0	-61.2	-13.0	-48.2		
		High Ch, 848.8MHz										
		1.6976	-5.3	V	3.0	40.2	1.0	-44.5	-13.0	-31.5		
		2.5466	-13.1	V	3.0	40.1	1.0	-52.1	-13.0	-39.1		
		3.3952	-14.2	V	3.0	39.5	1.0	-52.7	-13.0	-39.7		
		1.6976	-2.0	H	3.0	40.2	1.0	-41.2	-13.0	-28.2		
		2.5466	-10.2	H	3.0	40.1	1.0	-49.2	-13.0	-36.2		
		3.3952	-12.6	H	3.0	39.5	1.0	-51.1	-13.0	-38.1		
		Rev. 03.03.09										
		Note: No other emissions were detected above the system noise floor.										
		UL Korea, Ltd Suwon Laboratory Above 1GHz High Frequency Substitution Measurement										
		Company: Samsung										
		Project #: 15K20822										
		Date: 05-19-15										
		Test Engineer: Steven Kim										
		Configuration: EUT / AC Adapter / Earphone, X Position										
		Mode: GPRS 1900										
		Chamber	Pre-amplifier	Filter	Limit							
		Chamber 1	AFS42	Filter 1	Part 24							
		f GHz	SG reading (dBm)	Ant. Pol. (H/V)	Distance (m)	Preamp (dB)	Filter (dB)	EIRP (dBm)	Limit (dBm)	Delta (dB)	Notes	
		Low Ch, 1850.2MHz										
		3.7004	-1.6	V	3.0	39.2	1.0	-39.7	-13.0	-26.7		
		5.5506	-11.1	V	3.0	40.0	1.0	-50.0	-13.0	-37.0		
		7.4008	-9.5	V	3.0	39.2	1.0	-47.7	-13.0	-34.7		
		3.7004	-13.8	H	3.0	39.2	1.0	-52.0	-13.0	-39.0		
		5.5506	-11.3	H	3.0	40.0	1.0	-50.3	-13.0	-37.3		
		7.4008	-11.4	H	3.0	39.2	1.0	-49.6	-13.0	-36.6		
		Mid Ch, 1880.0MHz										
		3.7600	-9.9	V	3.0	39.1	1.0	-47.9	-13.0	-34.9		
		5.6400	-12.3	V	3.0	39.9	1.0	-51.2	-13.0	-38.2		
		7.5200	-11.7	V	3.0	39.1	1.0	-49.8	-13.0	-36.8		
		3.7600	-13.6	H	3.0	39.1	1.0	-51.7	-13.0	-38.7		
		5.6400	-12.1	H	3.0	39.9	1.0	-51.0	-13.0	-38.0		
		7.5200	-10.8	H	3.0	39.1	1.0	-49.0	-13.0	-36.0		
		High Ch, 1909.8 MHz										
		3.8196	-10.8	V	3.0	39.0	1.0	-48.8	-13.0	-35.8		
		5.7294	-11.3	V	3.0	39.9	1.0	-50.2	-13.0	-37.2		
		7.6392	-10.2	V	3.0	39.1	1.0	-48.3	-13.0	-35.3		
		3.8196	-9.4	H	3.0	39.0	1.0	-47.4	-13.0	-34.4		
		5.7294	-12.1	H	3.0	39.9	1.0	-51.0	-13.0	-38.0		
		7.6392	-11.0	H	3.0	39.1	1.0	-49.1	-13.0	-36.1		
		Rev. 03.03.09										
		Note: No other emissions were detected above the system noise floor.										