



**HAC RF EMISSIONS TEST REPORT**

**FCC 47 CFR § 20.19  
ANSI C63.19-2011**

*For*

**GSM/WCDMA/LTE 5G NR Phone + BT/BLE, DTS/UNII a/b/g/n/ac/ax, NFC, WPT and UWB**

**MODEL NUMBER : SM-F946U, SM-F946U1**

**FCC ID: A3LSMF946U**

**REPORT NUMBER: 4790748041-S4V2**

**ISSUE DATE: 5/17/2023**

*Prepared for*  
**SAMSUNG ELECTRONICS CO., LTD.  
129 SAMSUNG-RO, YEONGTONG-GU, SUWON-SI,  
GYEONGGI-DO, 16677, KOREA**

*Prepared by*

**UL Korea, Ltd.**

**26th floor, 152, Teheran-ro, Gangnam-gu Seoul, 06236, Korea**

**Suwon Test Site: UL Korea, Ltd. Suwon Laboratory  
218 Maeyeong-ro, Yeongtong-gu,  
Suwon-si, Gyeonggi-do, 16675, Korea  
TEL: (031) 337-9902  
FAX: (031) 213-5433**



**Testing Laboratory**

**TL-637**

**Revision History**

Rev.	Date	Revisions	Revised By
V1	5/12/2023	Initial Issue	-
V1	5/17/2023	Revised items - Corrected table and added notes in Sec.7 - Corrected table and added NR Band n38 in Sec.8.1 - Corrected table and added notes in Sec.12 - Removed n48 plots in Appendix C: Test Plots	Eunji Choi

## Table of Contents

<b>1. Attestation of Test Results</b> .....	<b>4</b>
<b>2. Test Methodology</b> .....	<b>5</b>
<b>3. Facilities and Accreditation</b> .....	<b>5</b>
<b>4. Calibration and Uncertainty</b> .....	<b>5</b>
4.1. <i>Measuring Instrument Calibration</i> .....	5
4.2. <i>Measurement Uncertainty</i> .....	6
4.3. <i>DECISION RULE</i> .....	6
<b>5. System Specifications</b> .....	<b>7</b>
<b>6. System Validation</b> .....	<b>8</b>
6.1. <i>System Validation Results</i> .....	9
<b>7. Average Antenna Input Power &amp; Evaluation for Low-power Exemption</b> .....	<b>10</b>
<b>8. Device Under Test</b> .....	<b>12</b>
8.1. <i>Air Interfaces and Operating Mode</i> .....	13
<b>9. Modulation Interference Factor (MIF)</b> .....	<b>14</b>
<b>10. HAC RF Emissions Test Procedure</b> .....	<b>16</b>
<b>11. RF Emissions Measurement Criteria</b> .....	<b>19</b>
<b>12. HAC (RF Emissions) Test Results</b> .....	<b>20</b>
12.1. <i>Worst Case RF Emission Test Plot</i> .....	23
<b>Appendixes</b> .....	<b>24</b>
4790748041-S4 Appendix A: <i>Setup Photo</i> .....	24
4790748041-S4 Appendix B: <i>System Validation Plots</i> .....	24
4790748041-S4 Appendix C: <i>Test Plots</i> .....	24
4790748041-S4 Appendix D: <i>MIF Attestation Letter</i> .....	24
4790748041-S4 Appendix E: <i>Probe Certificates</i> .....	24
4790748041-S4 Appendix F: <i>Dipole Certificates</i> .....	24
4790748041-S4 Appendix G: <i>UID Specifications</i> .....	24

# 1. Attestation of Test Results

Applicant Name	SAMSUNG ELECTRONICS CO., LTD.
FCC ID	A3LSMF946U
Model Name	SM-F946U, SM-F946U1
Applicable Standards	FCC 47 CFR § 20.19 ANSI C63.19-2011
HAC Rating	M3
Date Tested	5/8/2023 to 5/9/2023
Test Results	Pass

UL Korea, Ltd. tested the above equipment in accordance with the requirements set forth in the above standards. All indications of Pass/Fail in this report are opinions expressed by UL Korea, Ltd. based on interpretations and/or observations of test results. Measurement Uncertainties were not taken into account and are published for informational purposes only. The test results show that the equipment tested is capable of demonstrating compliance with the requirements as documented in this report..

**Note:** The results documented in this report apply only to the tested sample, under the conditions and modes of operation as described herein. This document may not be altered or revised in any way unless done so by UL Korea, Ltd. and all revisions are duly noted in the revisions section. Any alteration of this document not carried out by UL Korea, Ltd. will constitute fraud and shall nullify the document. This report must not be used by the client to claim product certification, approval, or endorsement by IAS, any agency of the Federal Government, or any agency of any government.

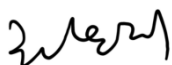
Approved & Released By: 	Prepared By: 
Justin Park Operations Leader UL Korea, Ltd. Suwon Laboratory	Eunji Choi Laboratory Test Engineer UL Korea, Ltd. Suwon Laboratory

## 2. Test Methodology

The tests documented in this report were performed in accordance with ANSI C63.19-2011 Methods of Measurement of Compatibility between Wireless Communications Devices and Hearing Aids and FCC Published procedure.

KDB 285076 D01 HAC Guidance v06r03

KDB 285076 D03 HAC FAQ v01r06

TCB workshop updates

## 3. Facilities and Accreditation

The test sites and measurement facilities used to collect data are located at

Suwon
SAR 2 Room (HAC)

UL Korea, Ltd. is accredited by IAS, Laboratory Code TL-637.

The full scope of accreditation can be viewed at <https://www.iasonline.org/wp-content/uploads/2017/05/TL-637-cert-New.pdf>.

## 4. Calibration and Uncertainty

### 4.1. Measuring Instrument Calibration

The measuring equipment utilized to perform the tests documented in this report has been calibrated in accordance with the manufacturer's recommendations, and is traceable to recognized national standards.

Name of Equipment	Manufacturer	Type/Model	Serial No.	Cal. Due Date
MXG Analog Signal Generator	Agilent	N5181A	MY50145882	8-4-2023
Power Sensor	Keysight	U2000A	MY60180020	8-3-2023
Power Sensor	Keysight	U2000A	MY54260007	8-3-2023
Power Amplifier	EXODUS	AMP2027ADB	10002	3-30-2023
Directional Coupler	Keysight	772D	MY52180193	8-3-2023
Directional Coupler	H.P	778D	16133	8-3-2023
Low Pass Filter	MICROLAB	LA-15N	3943	8-3-2023
Low Pass Filter	FILTRON	L14012FL	1410003S	8-3-2023
Attenuator	Keysight	8491B/010	MY39272011	8-2-2023
Attenuator	Keysight	8481B/020	MY39271973	8-3-2023
Attenuator	MINI-CIRCUITS	BW-S3W10+	N/A	4-7-2023
Data Acquisition Electronics	SPEAG	DAE4	1343	8-18-2023
E-Field Probe*	SPEAG	EF3DV3	912	11-16-2023
Calibration Dipole	SPEAG	CD835V3	1000	9-27-2023
Calibration Dipole	SPEAG	CD1880V3	1000	9-27-2023
Calibration Dipole	SPEAG	CD2450V3	1002	9-27-2023
Calibration Dipole	SPEAG	CD2600V3	1009	9-27-2023
Calibration Dipole	SPEAG	CD3500V3	1011	8-24-2023
Calibration Dipole	SPEAG	CD5500V3	1018	1-19-2024
Wireless Radio Communication Tester	R & S	CMW 500	150314	8-2-2023
UXM 5G Wireless Test Platform	Keysight	E7515B	MY57510596	8-5-2023

#### Note(s):

\*: According to SPEAG's Technical Report, "MIF Verification", Doc # TR-FB-12.09.04-1, issued date: 9/4/2012. E-field probes are calibrated with specified uncertainty according to ISO 17025 as described in their calibration certificate. The MIF according to the definition in ANSI C63.19 is specific for a modulation and can therefore be used as a constant value if the probe has been PMR calibrated.

## 4.2. Measurement Uncertainty

### Measurement Uncertainty for Radio Frequency Emissions Measurement

Error Description	Explanation	Uncertainty value (±%)	Probe Dist.	Divisor	(Ci) E	(Ci) H	Std. Unc.(±%) E
<b>Measurement System</b>							
Probe Calibration	A.1	<b>5.10</b>	Normal	1	1	1	5.10
Axial Isotropy	A.2	<b>4.70</b>	Rectangular	1.732	1	1	2.71
Sensor Displacement	A.3	<b>16.50</b>	Rectangular	1.732	1	0.145	9.53
Boundary Effects	A.4	<b>2.40</b>	Rectangular	1.732	1	1	1.39
Phantom Boundary Effects	A.5	<b>7.20</b>	Rectangular	1.732	1	0	4.16
Linearity	A.6	<b>4.70</b>	Rectangular	1.732	1	1	2.71
Scaling to PMR Calibration	A.7	<b>10.00</b>	Rectangular	1.732	1	1	5.77
System Detection Limit	A.8	<b>1.00</b>	Rectangular	1.732	1	1	0.58
Readout Electronics	A.9	<b>0.30</b>	Normal	1	1	1	0.30
Response Time	A.10	<b>0.80</b>	Rectangular	1.732	1	1	0.46
Integration Time	A.11	<b>2.60</b>	Rectangular	1.732	1	1	1.50
RF Ambient Conditions	A.12	<b>3.00</b>	Rectangular	1.732	1	1	1.73
RF Reflections	A.13	<b>12.00</b>	Rectangular	1.732	1	1	6.93
Probe Positioner	A.14	<b>1.20</b>	Rectangular	1.732	1	0.67	0.69
Probe Positioning	A.15	<b>4.70</b>	Rectangular	1.732	1	0.67	2.71
Extrapolation and Interpolation	A.16	<b>1.00</b>	Rectangular	1.732	1	1	0.58
<b>Test sample Related</b>							
Test Positioning Vertical	A.17	<b>4.70</b>	Rectangular	1.732	1	0.67	2.71
Test Positioning Lateral	A.18	<b>1.00</b>	Rectangular	1.732	1	1	0.58
Device Holder and Phantom	A.19	<b>2.40</b>	Rectangular	1.732	1	1	1.39
Power Drift	A.20	<b>5.00</b>	Rectangular	1.732	1	1	2.89
<b>Phantom and Setup Related</b>							
Phantom Thickness	A.21	<b>2.40</b>	Rectangular	1.732	1	0.67	1.39
Combined Std. Uncertainty							<b>16.31</b>
<b>Expanded Std. Uncertainty on Power (Coverage Factor for 95%, k = 2)</b>							<b>32.62</b>
<b>Expanded Std. Uncertainty on Field</b>							<b>16.31</b>
Notes for table							
1. Ci - is te sensitivity coefficient							
2. Expanded Std. Uncertainty on Power, Coverage Factor = 2, > 95% Confidence							
3. Expanded Std. Uncertainty on Field is half value of Expanded Std. Uncertainty on power							

## 4.3. DECISION RULE

Decision rule for statement(s) of conformity is based on Procedure 2, Clause 4.4.3 in IEC Guide 115:2021.

## 5. System Specifications

E-field measurements are performed using the DASY52 automated dosimetric assessment system. The DASY52 is made by Schmid & Partner Engineering AG (SPEAG) in Zurich, Switzerland.

The DASY52 HAC Extension consists of the following parts:

### Test Arch Phantom

The specially designed Test Arch allows high precision positioning of both the device and any of the validation dipoles.

### EF3DV3 Isotropic E-Field Probe

Construction:	One dipole parallel, two dipoles normal to probe axis Interleaved sensors Built-in shielding against static charges PEEK enclosure material
Calibration:	In air from 100 MHz to 3.0 GHz (absolute accuracy $\pm 6.0\%$ , $k=2$ ) ISO/IEC 17025 <u>calibration service</u> available.
Frequency:	40 MHz – >6 GHz (can be extended to < 20 MHz); Linearity: $\pm 0.2$ dB (100 MHz – 3 GHz)
Directivity:	$\pm 0.2$ dB in air (rotation around probe axis) $\pm 0.4$ dB in air (rotation normal to probe axis)
Dynamic Range:	2 V/m to > 1000 V/m; Linearity: $\pm 0.2$ dB
Dimensions:	Overall length: 337 mm (Tip: 20 mm) Tip diameter: 3.9 mm (Body: 12 mm) Distance from probe tip to dipole centers: 1.5 mm Sensor displacement to probe's calibration point: <0.7 mm
Application:	General near-field measurements up to 6 GHz HAC measurements up to 6 GHz Field component measurements Fast automatic scanning in phantoms

## 6. System Validation

The test setup was validated when first configured and verified periodically thereafter to ensure proper function. The procedure provided in this section is a validation procedure using dipole antennas for which the field levels were computed by numeric modeling.

Procedure:

Place a dipole antenna meeting the requirements given in ANSI C63.19 in the normally occupied by the WD.

The dipole antenna serves as a known source for an electrical and magnetic output. Position the E-field probe so that the following occurs:

- The probes and their cables are parallel to the coaxial feed of the dipole antenna
- The probe cables and the coaxial feed of the dipole antenna approach the measurement area from opposite directions
- The center point of the probe element(s) is 15 mm from the closest surface of the dipole elements.

Scan the length of the dipole with the E-field probe and record the two maximum values found near the dipole ends. Average the two readings and compare the reading to the expected value in the calibration certificate or the expected value in this standard.

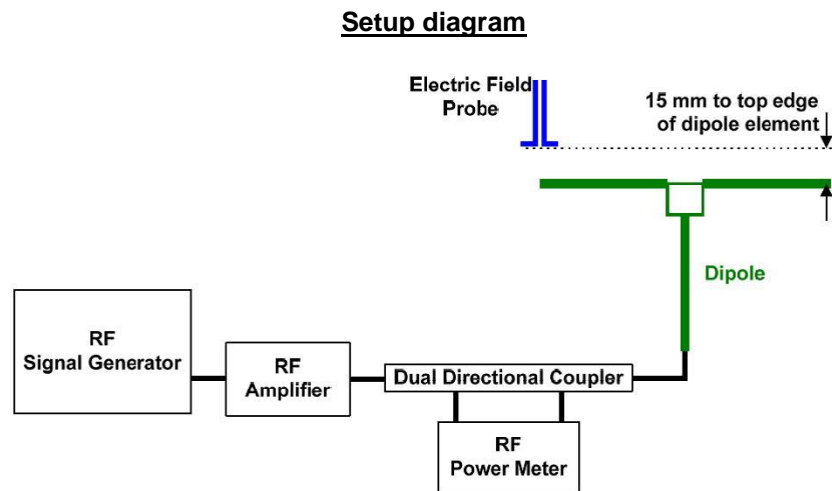



## 6.1. System Validation Results

SAR Lab	Date	Dipole Type_Serial #_Freq.	Dipole Cal. Due Data	Max. measured from		Average max. above arm (V/m)	Target (V/m) (From SPEAG)	Deviation (note 1) ± %	Plot No.
				above high end (V/m)	above low end (V/m)				
SAR 2	05-08-2023	CD835V3_SN:1000_(835MHz)	09-27-2023	117.60	116.30	116.95	107.90	8.39	1
SAR 2	05-08-2023	CD1880V3_SN:1000_(1880MHz)	09-27-2023	91.56	89.70	90.63	86.50	4.77	2
SAR 2	05-09-2023	CD2450V3_SN:1002_(2450MHz)	09-27-2023	87.77	86.70	87.24	84.80	2.87	3
SAR 2	05-08-2023	CD2600V3_SN:1009_(2600MHz)	09-27-2023	90.30	88.67	89.49	84.70	5.65	4
SAR 2	05-09-2023	CD2600V3_SN:1009_(2600MHz)	08-24-2023	90.38	89.47	89.93	84.70	6.17	5
SAR 2	05-09-2023	CD3500V3_SN:1011_(3500MHz)	08-24-2023	85.71	84.47	85.09	82.40	3.26	6
SAR 2	05-09-2023	CD5500V3_SN:1018_(5500MHz)	01-19-2024	103.70	103.70	103.70	100.60	3.08	7

### Notes:

- 1) Delta (Deviation) % =  $100 * (\text{Measured value} - \text{Target value}) / \text{Target value}$ . Deltas within  $\pm 18\%$  are acceptable, of which 12% is deviation and 13% is measurement uncertainty.
- 2) The maximum E-field were evaluated and compared to the target values provided by SPEAG in the calibration certificate of specific dipoles.
- 3) Please refer to the appendix for detailed measurement data and plots.

## 7. Average Antenna Input Power & Evaluation for Low-power Exemption

An RF air interface technology of a device is exempt from testing when its average antenna input power plus its **MIF is  $\leq 17$  dBm** for any of its operating modes. If a device supports multiple RF air interfaces, each RF air interface shall be evaluated individually.

Air-Interface	Antenna	Average Antenna Input Power (dBm) <sup>1</sup>	Worst Case MIF (dB)	Input Power plus its MIF (dBm)	HAC Tested
GSM850	A, A+B	33.0	3.63	36.63	Yes
GSM1900	B	30.5	3.63	34.13	Yes
W-CDMA Band II	B	24.8	-27.23	-2.43	No
W-CDMA Band IV	B	24.8	-27.23	-2.43	No
W-CDMA Band V	A, A+B	25.5	-27.23	-1.73	No
LTE Band 2	B	25.0	-9.76	15.24	No
LTE Band 4	B	25.0	-9.76	15.24	No
LTE Band 5	A, A+B	25.5	-9.76	15.74	No
LTE Band 7	B	25.0	-9.76	15.24	No
LTE Band 12	A, A+B	25.5	-9.76	15.74	No
LTE Band 13	A, A+B	25.5	-9.76	15.74	No
LTE Band 14	A, A+B	25.5	-9.76	15.74	No
LTE Band 25	B	25.0	-9.76	15.24	No
LTE Band 26	A, A+B	25.5	-9.76	15.74	No
LTE Band 30	B	24.0	-9.76	14.24	No
LTE Band 66	B	25.0	-9.76	15.24	No
LTE Band 71	A, A+B	25.5	-9.76	15.74	No
LTE Band 38	B	25.0	-1.44	23.56	Yes
LTE Band 41 PC3	B	25.0	-1.44	23.56	Yes
LTE Band 41 PC2	B	26.5	-1.44	25.06	Yes
LTE Band 48	F	24.0	-1.44	22.56	Yes
LTE Band 2	F	25.0	-9.76	15.24	No
LTE Band 4	F	25.0	-9.76	15.24	No
LTE Band 7	F	25.0	-9.76	15.24	No
LTE Band 25	F	25.0	-9.76	15.24	No
LTE Band 30	F	24.0	-9.76	14.24	No
LTE Band 66	F	25.0	-9.76	15.24	No
LTE Band 41 PC3	F	25.0	-1.44	23.56	Yes
LTE Band 41 PC2	F	26.5	-1.44	25.06	Yes

### Note(s):

1. Max tune-up limit.
2. Testing for all UL CA is not required because it uses same Tx band, modulations, and output power is equal or less than non-CA modes.
3. LTE Band 38 is covered by LTE Band 41, as LTE Band 41 is a superset and contains all the channels from LTE Band 38, using the same modulations, bandwidths and power limits.

**Average Antenna Input Power & Evaluation for Low-power Exemption (Continued)**

Air-Interface	Antenna	Average Antenna Input Power (dBm) <sup>1</sup>	Worst Case MIF (dB)	Input Power plus its MIF (dBm)	HAC Tested
NR Band n2	B	24.5	-15.07	9.43	No
NR Band n5	A, A+B	25.5	-15.06	10.44	No
NR Band n7	B	24.0	-15.07	8.93	No
NR Band n12	A, A+B	25.5	-15.06	10.44	No
NR Band n25	B	24.5	-15.07	9.43	No
NR Band n26	A, A+B	25.5	-15.06	10.44	No
NR Band n30	B	23.5	-15.06	8.44	No
NR Band n66	B	24.5	-15.07	9.43	No
NR Band n71	A, A+B	25.5	-15.06	10.44	No
NR Band n38	F	25.0	-16.68	8.32	No
NR Band n41 PC3	B	25.0	-1.64	23.36	Yes
NR Band n41 PC2	B	26.0	-1.64	24.36	Yes
NR Band n48	F	24.0	-16.68	7.32	No
NR Band n77 PC3	F	24.0	-1.64	22.36	Yes
NR Band n77 PC2	F	27.0	-1.64	25.36	Yes
NR Band n2	F	24.0	-15.07	8.93	No
NR Band n7	F	24.0	-15.07	8.93	No
NR Band n25	F	24.0	-15.07	8.93	No
NR Band n30	F	23.5	-15.06	8.44	No
NR Band n66	F	24.0	-15.07	8.93	No
NR Band n41 PC3	F	25.0	-1.64	23.36	Yes
NR Band n41 PC2	F	27.0	-1.64	25.36	Yes
Wi-Fi 2.4 GHz 802.11b Antenna 2		19.0	-2.02	16.98	No
Wi-Fi 2.4 GHz 802.11g Antenna 2		18.0	0.12	18.12	Yes
Wi-Fi 2.4 GHz 802.11n Antenna 2		18.0	-5.59	12.41	No
Wi-Fi 2.4 GHz 802.11ax Antenna 2		18.0	-5.58	12.42	No
Wi-Fi 2.4 GHz 802.11b MIMO		22.0	-2.02	19.98	Yes
Wi-Fi 2.4 GHz 802.11g MIMO		21.0	0.12	21.12	Yes
Wi-Fi 5 GHz 802.11a MIMO		21.0	-3.15	17.85	Yes
Wi-Fi 2.4 GHz 802.11n MIMO		21.0	-5.59	15.41	No
Wi-Fi 5 GHz 802.11n MIMO		21.0	-5.59	15.41	No
Wi-Fi 5 GHz 802.11ac MIMO		21.0	-5.57	15.43	No
Wi-Fi 2.4 GHz 802.11ax MIMO		21.0	-5.58	15.42	No
Wi-Fi 5 GHz 802.11ax MIMO		21.0	-5.58	15.42	No

**Note(s):**

1. Max tune-up limit.
2. The device supports SISO Ant.2 and MIMO in Wi-Fi 2.4GHz.
3. The device supports only MIMO in Wi-Fi 5GHz.

## 8. Device Under Test

Normal operation	Held to head	
Back Cover	The Back Cover is not removable	
Test sample information	<b>S/N</b>	<b>Notes</b>
	R3CW30K7E5R	RF Emission Test
	R3CW20P0LZB	RF Emission Test
	R3CW30K67YT	RF Emission Test

### 8.1. Air Interfaces and Operating Mode

Air Interface	Bands (MHz)	Type	C63.19 Tested	Simultaneous Transmitter	OTT Testing Required? Name of Voice Service	Power Reduction
GSM	850	VO	Yes	Wi-Fi and BT	CMRS	NA
	1900					No
	GPRS/EDGE	VD	No	Wi-Fi and BT	Google Meet	NA
W-CDMA (UMTS)	850 (V)	VO	No <sup>1</sup>	Wi-Fi and BT	CMRS	NA
	1750 (IV)					
	1900 (II)	VD	No <sup>1</sup>	Wi-Fi and BT	Google Meet	NA
HSPA						
LTE - FDD	680 (B71)	VD	No <sup>1</sup>	NR, Wi-Fi and BT	VoLTE Google Meet	NA
	700 (B12)					
	780 (B13)					
	790 (B14)					
	850 (B5/26)					
	1700 (B4/66)					
	1900 (B2/25)					
	2300 (B30)					
2600 (B7)						
LTE - TDD	2600 (B38/41)	VD	Yes	NR, Wi-Fi and BT	VoLTE Google Meet	NA
	3600 (B48)					
NR - FDD	680 (n71)	VD	No <sup>1</sup>	LTE, Wi-Fi and BT	VoNR Google Meet	NA
	700 (n12)					
	850 (n5/26)					
	1700 (n66)					
	1900 (n2/25)					
	2300 (n30)					
2600 (n7)						
NR - TDD	2600 (n38)	VD	No <sup>1</sup>	LTE, Wi-Fi and BT	VoNR Google Meet	NA
	2600 (n41)		Yes			
	3600 (n48)		No <sup>1</sup>			
	3500 (n77 DoD)		Yes			
	3700 (n77)					
Wi-Fi	2450	VD	Yes	WWAN, BT and U-NII	VoWiFi Google Meet	NA
	5200 (U-NII-1)			WWAN, BT and WiFi 2.4GHz		
	5300 (U-NII-2A)					
	5500 (U-NII-2C)					
	5800 (U-NII-3)					
	5900 (U-NII-4)					
BT	2450	DT	NA	WWAN and U-NII	NA	NA

Type

- VO: Legacy Cellular Voice Service
- DT: Digital Transport only (no voice)
- VD: IP Voice Service over Digital Transport
- CMRS: Commercial Mobile Radio Service
- BT: Bluetooth

Note:

- <sup>1</sup>: Evaluated for MIF and low power exemption

## 9. Modulation Interference Factor (MIF)

The HAC Standard ANSI C63.19 defines a new scaling using the Modulation Interference Factor (MIF) which replaces the need for the Articulation Weighting Factor (AWF) during the evaluation and is applicable to any modulation scheme.

The Modulation Interference factor (MIF, in dB) is added to the measured average E-field (in dBV/m) and converts it to the RF Audio Interference level (in dBV/m). This level considers the audible amplitude modulation components in the RF E-field. CW fields without amplitude modulation are assumed to not interfere with the hearing aid electronics. Modulations without time slots and low fluctuations at low frequencies have low MIF values, TDMA modulations with narrow transmission and repetition rates of few 100 Hz have high MIF values and give similar classifications as ANSI C63.19.

### Definitions

E-field probes have a bandwidth <10 kHz and can therefore not evaluate the RF envelope in the full audio band. DASY52 is therefore using the "indirect" measurement method according to ANSI C63.19 which is the primary method. These near field probes read the averaged E-field measurement. Especially for the new high peak-to-average (PAR) signal types, the probes shall be linearized by probe modulation response (PMR) calibration in order to not overestimate the field reading.

The evaluation method of the MIF is defined in ANSI C63.19 section D.7. An RMS demodulated RF signal is fed to a spectral filter (similar to an A weighting filter) and forwarded to a temporal filter acting as a quasi-peak detector. The averaged output of these filtering is called to a 1 kHz 80% AM signal as reference. MIF measurement requires additional instrumentation and is not well suited for evaluation by the end user with reasonable uncertainty. It may alternatively be determined through analysis and simulation, because it is constraint and characteristic for a communication signal. DASY52 uses well defined signals for PMR calibration. The MIF of these signals has been determined by simulation and is automatically applied.

MIF values were not tested by a probe or as specified in the standards but are based on analysis provided by SPEAG for all the air interfaces (GSM, WCDMA, LTE, and Wi-Fi). The data included in this report are for the worst case operating modes. The UIDs used are listed below:

UID	Communication System Name	MIF (dB)
10021-DAC	GSM-FDD (TDMA, GMSK)	3.63
10011-CAC	UMTS-FDD (WCDMA)	-27.23
10170-CAF	LTE-FDD (SC-FDMA, 1 RB, 20 MHz, 16QAM)	-9.76
10182-CAF	LTE-FDD (SC-FDMA, 1 RB, 15 MHz, 16QAM)	-9.76
10176-CAH	LTE-FDD (SC-FDMA, 1 RB, 10 MHz, 16QAM)	-9.76
10173-CAH	LTE-TDD (SC-FDMA, 1 RB, 20 MHz, 16QAM)	-1.44
10061-CAB	IEEE 802.11b WiFi 2.4 GHz (DSSS, 11 Mbps)	-2.02
10077-CAB	IEEE 802.11g WiFi 2.4 GHz (DSSS/OFDM, 54 Mbps)	0.12
10069-CAD	IEEE 802.11a/h WiFi 5 GHz (OFDM, 54 Mbps)	-3.15
10591-AAC	IEEE 802.11n (HT Mixed, 20MHz, MCS0, 90pc dc)	-5.59
10599-AAC	IEEE 802.11n (HT Mixed, 40MHz, MCS0, 90pc dc)	-5.59
10607-AAC	IEEE 802.11ac WiFi (20MHz, MCS0, 90pc dc)	-5.60
10616-AAC	IEEE 802.11ac WiFi (40MHz, MCS0, 90pc dc)	-5.57
10626-AAC	IEEE 802.11ac WiFi (80MHz, MCS0, 90pc dc)	-5.64
10671-AAC	IEEE 802.11ax WiFi (20MHz, MCS0, 90pc dc)	-5.58
10695-AAC	IEEE 802.11ax WiFi (40MHz, MCS0, 90pc dc)	-6.01
10719-AAC	IEEE 802.11ax WiFi (80MHz, MCS0, 90pc dc)	-6.04
10929-AAC	5G NR (DFT-s-OFDM, 1 RB, 10 MHz, QPSK, 15 kHz)	-15.06
10930-AAC	5G NR (DFT-s-OFDM, 1 RB, 15 MHz, QPSK, 15 kHz)	-15.06
10931-AAC	5G NR (DFT-s-OFDM, 1 RB, 20 MHz, QPSK, 15 kHz)	-15.06
10934-AAC	5G NR (DFT-s-OFDM, 1 RB, 40 MHz, QPSK, 15 kHz)	-15.07
10903-AAB	5G NR (DFT-s-OFDM, 1 RB, 40 MHz, QPSK, 30 kHz)	-16.68
10973-AAB	5G NR (DFT-s-OFDM, 1 RB, 100 MHz, QPSK, 30 kHz)	-1.64

A PMR calibrated probe is linearized for the selected waveform over the full dynamic range within the uncertainty specified in its calibration certificate. E-field probes have a bandwidth <10 kHz and can therefore not evaluate the RF envelope in the full audio band. DASY52 is therefore using the "indirect" measurement method according to ANSI C63.19 which is the primary method. These near field probes read the averaged E-field measurement. Especially for the new high peak-to-average (PAR) signal types, the probes shall be linearized by PMR calibration in order to not overestimate the field reading.

The MIF measurement uncertainty is estimated as follows, for modulation frequencies from slotted waveforms with fundamental frequency and at least 2 harmonics within 10 kHz:

- 0.2 dB for MIF -7 to +5 dB,
- 0.5 dB for MIF -13 to +11 dB
- 1 dB for MIF > -20 dB

## 10. HAC RF Emissions Test Procedure

The following are step-by-step test procedures.

- a) Confirm proper operation of the field probe, probe measurement system and other instrumentation and the positioning system.
- b) Position the WD in its intended test position.
- c) Set the WD to transmit a fixed and repeatable combination of signal power and modulation characteristic that is representative of the worst case (highest interference potential) encountered in normal use. Transiently occurring start-up, changeover, or termination conditions, or other operations likely to occur less than 1% of the time during normal operation, may be excluded from consideration.
- d) The center sub-grid shall be centered on the T-Coil mode perpendicular measurement point or the acoustic output, as appropriate. Locate the field probe at the initial test position in the 50 mm by 50 mm grid, which is contained in the measurement plane, refer to illustrated in Figure 1. If the field alignment method is used, align the probe for maximum field reception.
- e) Record the reading at the output of the measurement system
- f) Scan the entire 50 mm by 50 mm region in equally spaced increments and record the reading at each measurement point. The distance between measurement points shall be sufficient to assure the identification of the maximum reading.
- g) Identify the five contiguous sub-grids around the center sub-grid whose maximum reading is the lowest of all available choices. This eliminates the three sub-grids with the maximum readings. Thus, the six areas to be used to determine the WD's highest emissions are identified.
- h) Identify the maximum reading within the non-excluded sub-grids identified in step g).
- i) Convert the highest field reading within identified in step h) to RF audio interference level, in V/m, by taking the square root of the reading and then dividing it by the measurement system transfer function, established in 5.5.1.1 Convert this result to dB(V/m) by taking the base-10 logarithm and multiplying by 20.

### Indirect measurement method

Replacing step i), the RF audio interference level in dB (V/m) is obtained by adding the MIF (in dB) to the maximum steady-state rms field-strength reading, in dB (V/m), from step h). Use this result to determine the category rating

- j) Compare this RF audio interference level with the categories in Clause 8 (ANSI C63.19) and record the resulting WD category rating
- k) For the T-Coil mode M-rating assessment, determine whether the chosen perpendicular measurement point is contained in an included sub-grid of the first scan. If so, then a second scan is not necessary. The first scan and resultant category rating may be used for the T-Coil mode M rating.

Otherwise, repeat step a) through step i), with the grid shifted so that it is centered on the perpendicular measurement point. Record the WD category rating.





Figure 1 - WD reference and plane for RF emission measurements

## Test flowchart Per ANSI-63.19-2011

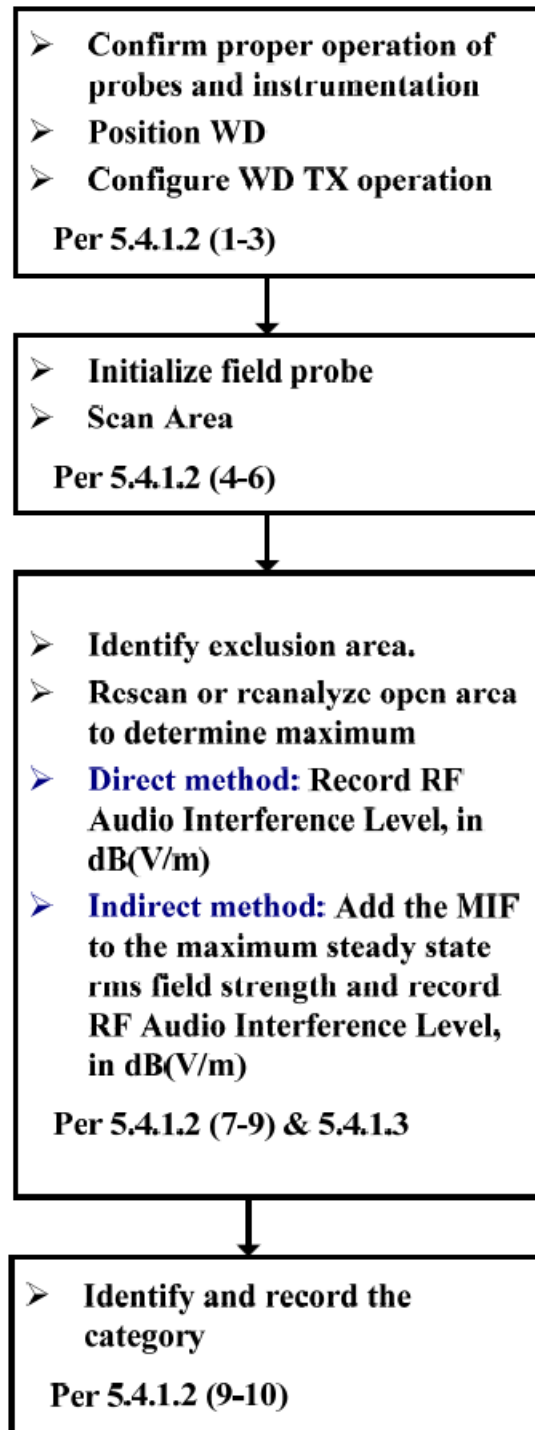

## 11. RF Emissions Measurement Criteria

WD RF audio interference level categories in logarithmic units

Emission Categories	E-field emissions	
	< 960 MHz	> 960 MHz
Category M1	50 to 55 dB (V/m)	40 to 45 dB (V/m)
Category M2	45 to 50 dB (V/m)	35 to 40 dB (V/m)
Category M3	40 to 45 dB (V/m)	30 to 35 dB (V/m)
Category M4	<40 dB (V/m)	<30 dB (V/m)

## 12. HAC (RF Emissions) Test Results

MIF values were not tested by a probe or as specified in the standards but are based on analysis provided by SPEAG for the following User Identifiers and air interfaces.

The data included in this report are for the worst case operating modes. Refer to Appendix D and G for the MIF values that represent the worst case operation modes.

Air-Interface	Ch. No.	Freq. (MHz)	Results* (dB V/m)	Results plus 0.2dB uncertainty (dB V/m)	Margin (dB)	M-Rating	Plot No.
GSM850 (Ant.A+Ant.B)	128	824.2	32.23	32.43	7.57	M4	1
	190	836.6	32.53	32.73	7.27	M4	2
	251	848.6	33.35	33.55	6.45	M4	3
GSM850 (Ant.A only)	128	824.2	32.11	32.31	7.69	M4	4
	190	836.6	31.90	32.10	7.90	M4	5
	251	848.6	32.50	32.70	7.30	M4	6
GSM1900 (Ant.B)	512	1850.2	23.38	23.58	6.42	M4	7
	661	1880	23.06	23.26	6.74	M4	8
	810	1909.8	23.26	23.46	6.54	M4	9
LTE-TDD Band 41 20MHz BW 16QAM RB1/0 (PC3, Ant.B)	39750	2506	15.99	16.19	13.81	M4	10
	40185	2549.5	15.55	15.75	14.25	M4	11
	40620	2593	14.59	14.79	15.21	M4	12
	41055	2636.5	17.09	17.29	12.71	M4	13
	41490	2680	17.54	17.74	12.26	M4	14
LTE-TDD Band 41 20MHz BW 16QAM RB1/0 (PC2, Ant.B)	39750	2506	15.94	16.14	13.86	M4	15
	40185	2549.5	16.18	16.38	13.62	M4	16
	40620	2593	16.09	16.29	13.71	M4	17
	41055	2636.5	17.69	17.89	12.11	M4	18
	41490	2680	17.79	17.99	12.01	M4	19
LTE-TDD Band 41 20MHz BW 16QAM RB1/0 (PC3, Ant.F)	39750	2506	24.71	24.91	5.09	M4	20
	40185	2549.5	26.12	26.32	3.68	M4	21
	40620	2593	26.85	27.05	2.95	M4	22
	41055	2636.5	26.65	26.85	3.15	M4	23
	41490	2680	25.91	26.11	3.89	M4	24
LTE-TDD Band 41 20MHz BW 16QAM RB1/0 (PC2, Ant.F)	39750	2506	25.69	25.89	4.11	M4	25
	40185	2549.5	27.80	28.00	2.00	M4	26
	40620	2593	30.08	30.28	4.72	M3	27
	41055	2636.5	29.32	29.52	0.48	M4	28
	41490	2680	27.64	27.84	2.16	M4	29
LTE-TDD Band 48 20MHz BW 16QAM RB1/0 (Ant.F)	55340	3560	24.32	24.52	5.48	M4	30
	55773	3603.3	24.57	24.77	5.23	M4	31
	56207	3646.7	25.53	25.73	4.27	M4	32
	56640	3690	26.30	26.50	3.50	M4	33

### Note(s):

\*: Measured Audio Interference level in dB (V/m): indirect method (max rms field strength Plus MIF)

Additionally, the device was tested with the folder opened configuration for HAC testing using worst-case in folder closed configuration. (for use against the head test case)

**HAC (RF Emissions) Test Results (Continued)**

Air-Interface	Ch. No.	Freq. (MHz)	Results* (dB V/m)	Results plus 0.2dB uncertainty (dB V/m)	Margin (dB)	M-Rating	Plot No.
NR-TDD Band n41 100MHz BW DFT-s-OFDM QPSK RB1/1 (PC3, Ant.B)	509202	2546.01	15.57	15.77	14.23	M4	34
	518598	2592.99	16.26	16.46	13.54	M4	35
	528000	2640	16.02	16.22	13.78	M4	36
NR-TDD Band n41 100MHz BW DFT-s-OFDM QPSK RB1/1 (PC2, Ant.B)	509202	2546.01	15.92	16.12	13.88	M4	37
	518598	2592.99	16.26	16.46	13.54	M4	38
	528000	2640	15.89	16.09	13.91	M4	39
NR-TDD Band n41 100MHz BW DFT-s-OFDM QPSK RB1/1 (PC3, Ant.F)	509202	2546.01	22.82	23.02	6.98	M4	40
	518598	2592.99	23.94	24.14	5.86	M4	41
	528000	2640	24.49	24.69	5.31	M4	42
NR-TDD Band n41 100MHz BW DFT-s-OFDM QPSK RB1/1 (PC2, Ant.F)	509202	2546.01	23.73	23.93	6.07	M4	43
	518598	2592.99	24.95	25.15	4.85	M4	44
	528000	2640	25.38	25.58	4.42	M4	45
NR-TDD Band n77 100MHz BW DFT-s-OFDM QPSK RB1/1 (PC3, Ant.F)	633334	3500.01	18.32	18.52	11.48	M4	46
	650000	3750	23.03	23.23	6.77	M4	47
	656000	3840	24.69	24.89	5.11	M4	48
	662000	3930	25.46	25.66	4.34	M4	49
NR-TDD Band n77 100MHz BW DFT-s-OFDM QPSK RB1/1 (PC2, Ant.F)	633334	3500.01	20.48	20.68	9.32	M4	50
	650000	3750	24.94	25.14	4.86	M4	51
	656000	3840	26.52	26.72	3.28	M4	52
	662000	3930	27.55	27.75	2.25	M4	53
WiFi 2.4 GHz 802.11g 54 Mbps SISO Ant.2	1	2412	25.33	25.53	4.47	M4	54
	6	2437	26.42	26.62	3.38	M4	55
	11	2462	26.73	26.93	3.07	M4	56
WiFi 2.4 GHz 802.11b 11 Mbps MIMO	1	2412	25.25	25.45	4.55	M4	57
	6	2437	28.00	28.20	1.80	M4	58
	11	2462	28.62	28.82	1.18	M4	59
WiFi 2.4 GHz 802.11g 54 Mbps MIMO	1	2412	26.07	26.27	3.73	M4	60
	6	2437	26.55	26.75	3.25	M4	61
	11	2462	27.37	27.57	2.43	M4	62

**Note(s):**

\*: Measured Audio Interference level in dB (V/m): indirect method (max rms field strength Plus MIF)

**HAC (RF Emissions) Test Results (Continued)**

Air-Interface	Ch. No.	Freq. (MHz)	Results* (dB V/m)	Results plus 0.2dB uncertainty (dB V/m)	Margin (dB)	M-Rating	Plot No.
WiFi 5 GHz 802.11a 54 Mbps UNII-1 MIMO	36	5180	14.44	14.64	15.36	M4	63
	40	5200	14.28	14.48	15.52	M4	64
	48	5240	14.10	14.30	15.70	M4	65
WiFi 5 GHz 802.11a 54 Mbps UNII-2A MIMO	52	5260	14.12	14.32	15.68	M4	66
	56	5280	14.03	14.23	15.77	M4	67
	64	5320	14.88	15.08	14.92	M4	68
WiFi 5 GHz 802.11a 54 Mbps UNII-2C MIMO	100	5500	17.72	17.92	12.08	M4	69
	120	5600	18.23	18.43	11.57	M4	70
	144	5720	18.12	18.32	11.68	M4	71
WiFi 5 GHz 802.11a 54 Mbps UNII-3 MIMO	149	5745	17.98	18.18	11.82	M4	72
	157	5785	17.35	17.55	12.45	M4	73
	165	5825	16.72	16.92	13.08	M4	74
WiFi 5 GHz 802.11a 54 Mbps UNII-4 MIMO	169	5845	16.59	16.79	13.21	M4	75
	173	5865	16.33	16.53	13.47	M4	76
	177	5885	16.48	16.68	13.32	M4	77
W-CDMA & LTE-FDD & NR-FDD	Refer to Section 7 Evaluation for Low-power Exemption. RF Emission testing for this device is required only for GSM voice modes, LTE-TDD, NR-TDD and Wi-Fi. All other applicable air-interfaces are exempt from testing in accordance with C63.19 Clause 4.4 and are rated M4.					M4	N/A

**Note(s):**

\*: Measured Audio Interference level in dB (V/m); indirect method (max rms field strength Plus MIF)

**Additional Test - Folder Opened Configuration**

Air-Interface	Ch. No.	Freq. (MHz)	Results* (dB V/m)	Results plus 0.2dB uncertainty (dB V/m)	Margin (dB)	M-Rating	Plot No.	Configuration
LTE-TDD Band 41 20MHz BW 16QAM RB1/0 (PC2, Ant.F)	40620	2593	28.29	28.49	1.51	M4	78	Folder Opened - Front
	40620	2593	28.57	28.77	1.23	M4	79	Folder Opened - Back

**Note(s):**

\*: Measured Audio Interference level in dB (V/m); indirect method (max rms field strength Plus MIF)

Additionally, the device was tested with the folder opened configuration for HAC testing using worst-case in folder closed configuration. (for use against the head test case)

## 12.1. Worst Case RF Emission Test Plot

Test Laboratory: UL Korea Ltd. Suwon Laboratory

Date: 5/9/2023

### 2600

Communication System: UID 10173 - CAH, LTE-TDD (SC-FDMA, 1 RB, 20 MHz, 16-QAM); Frequency: 2593 MHz; Duty Cycle: 1:8.8736

Phantom section: RF Section

DASY5 Configuration:

- Probe: EF3DV3 - SN4064; ConvF(1, 1, 1) @ 2593 MHz; Calibrated: 11/17/2022
- Sensor-Surface: (Fix Surface)
- Electronics: DAE4 Sn912; Calibrated: 11/16/2022
- Phantom: HAC Test Arch with AMCC; Type: SD HAC P01 BA
- Measurement SW: DASY52, Version 52.10 (4);SEMCAD X Version 14.6.14 (7483)

### LTE Band 41 PC2 E-Field measurement (Ant.F)/Voice\_ch 40620 RB 1/0/Hearing Aid Compatibility Test (101x101x1): Interpolated grid: dx=0.5000 mm, dy=0.5000 mm

Device Reference Point: 0, 0, -6.3 mm

Reference Value = 35.05 V/m; Power Drift = -0.00 dB

Applied MIF = -1.44 dB

RF audio interference level = 30.08 dBV/m

Emission category: **M3**

MIF scaled E-field

Grid 1 <b>M4</b> 27.26 dBV/m	Grid 2 <b>M3</b> 30.14 dBV/m	Grid 3 <b>M3</b> 30.25 dBV/m
Grid 4 <b>M4</b> 25.57 dBV/m	Grid 5 <b>M3</b> 30.08 dBV/m	Grid 6 <b>M3</b> 30.22 dBV/m
Grid 7 <b>M4</b> 27.14 dBV/m	Grid 8 <b>M4</b> 29.88 dBV/m	Grid 9 <b>M4</b> 29.92 dBV/m

**Cursor:**

Total = 30.25 dBV/m

E Category: M3

Location: -12, -11, 7.7 mm

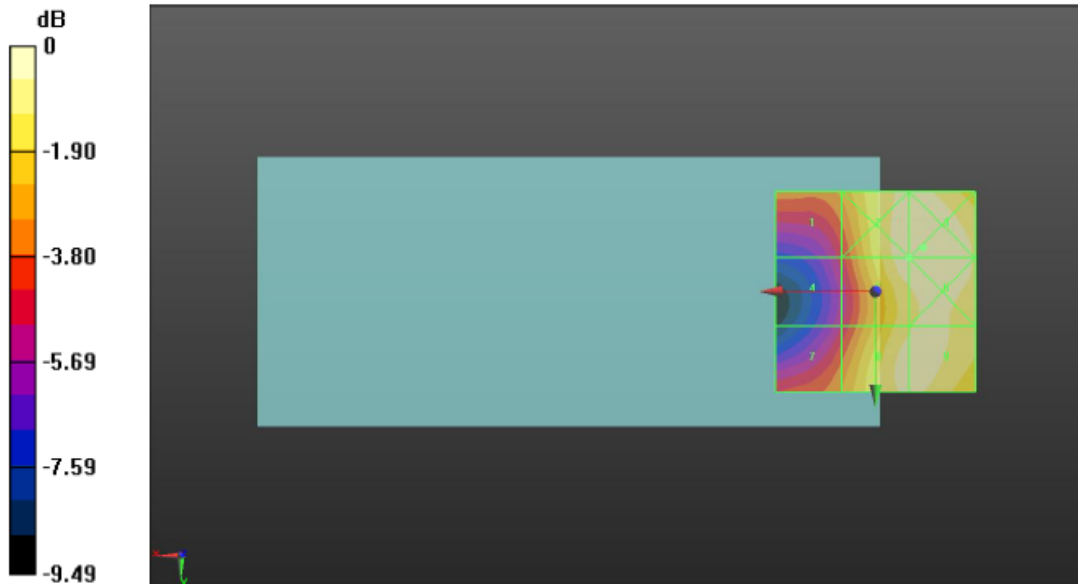

0 dB = 32.54 V/m = 30.25 dBV/m

## **Appendixes**

**Refer to separated files for the following appendixes**

**4790748041-S4 Appendix A: Setup Photo**

**4790748041-S4 Appendix B: System Validation Plots**

**4790748041-S4 Appendix C: Test Plots**

**4790748041-S4 Appendix D: MIF Attestation Letter**

**4790748041-S4 Appendix E: Probe Certificates**

**4790748041-S4 Appendix F: Dipole Certificates**

**4790748041-S4 Appendix G: UID Specifications**

**END OF REPORT**