

FCC LTE REPORT

FCC Certification

Applicant Name:
 SAMSUNG Electronics Co., Ltd.

Date of Issue:
 May 16, 2016

Address:
 129, Samsung-ro, Yeongtong-gu, Suwon-si,
 Gyeonggi-do, 16677, Rep. of Korea

Location:
 HCT CO., LTD.,
 74, Seoicheon-ro 578beon-gil, Majang-myeon,
 Icheon-si, Gyeonggi-do, 17383, Rep. of KOREA

Report No.: HCT-R-1605-F017
HCT FRN: 0005866421

FCC ID: A3LSMC5000

APPLICANT: SAMSUNG Electronics Co., Ltd.

FCC Model(s): SM-C5000
EUT Type: Mobile Phone
FCC Classification: Licensed Portable Transmitter Held to Ear (PCE)
FCC Rule Part(s): §2 , §27

Primary Antenna

Mode (MHz)	Tx Frequency (MHz)	Emission Designator	Modulation	EIRP	
				Max. Power (W)	Max. Power (dBm)
LTE – Band41 (5)	2557.5-2652.5	4M47G7D	QPSK	0.163	22.13
		4M46W7D	16QAM	0.116	20.63
LTE – Band41 (10)	2560.0-2650.0	8M95G7D	QPSK	0.163	22.12
		8M94W7D	16QAM	0.119	20.77
LTE – Band41 (15)	2562.5-2647.5	13M4G7D	QPSK	0.171	22.32
		13M4W7D	16QAM	0.118	20.73
LTE – Band41 (20)	2565.0-2645.0	18M0G7D	QPSK	0.163	22.13
		17M9W7D	16QAM	0.118	20.70

Diversity Antenna

Mode (MHz)	Tx Frequency (MHz)	Modulation	EIRP	
			Max. Power (W)	Max. Power (dBm)
LTE – Band41 (5)	2557.5 – 2652.5	QPSK	0.086	19.34
		16QAM	0.072	18.55
LTE – Band41 (10)	2560.0 – 2650.0	QPSK	0.085	19.31
		16QAM	0.072	18.56
LTE – Band41 (15)	2562.5 – 2647.5	QPSK	0.085	19.30
		16QAM	0.071	18.50
LTE – Band41 (20)	2565.0 – 2645.0	QPSK	0.084	19.25
		16QAM	0.070	18.45

The measurements shown in this report were made in accordance with the procedures specified in CFR47 section §2.947. I assume full responsibility for the accuracy and completeness of these measurements, and for the qualifications of all persons taking them.

HCT CO., LTD. Certifies that no party to this application has subject to a denial of Federal benefits that includes FCC benefits pursuant to section 5301 of the Anti-Drug Abuse Act of 1998, 21 U.S. C.853(a)



Report prepared by
: Jeong Ho Kim
Test engineer of RF Team



Approved by
: Kyoung Houn Seo
Manager of RF Team

This report only responds to the tested sample and may not be reproduced, except in full, without written approval of the HCT Co., Ltd.

Version

TEST REPORT NO.	DATE	DESCRIPTION
HCT-R-1605-F017	May 16, 2016	- First Approval Report

Table of Contents

1. GENERAL INFORMATION	5
2. INTRODUCTION	6
2.1. EUT DESCRIPTION.....	6
2.2. MEASURING INSTRUMENT CALIBRATION.....	6
2.3. TEST FACILITY	6
3. DESCRIPTION OF TESTS	7
3.1 EIRP RADIATED POWER AND RADIATED SPURIOUS EMISSIONS	7
3.2 OCCUPIED BANDWIDTH.	8
3.3 SPURIOUS AND HARMONIC EMISSIONS AT ANTENNA TERMINAL.....	9
3.4 FREQUENCY STABILITY / VARIATION OF AMBIENT TEMPERATURE	10
4. LIST OF TEST EQUIPMENT	11
5. MEASUREMENT UNCERTAINTY	12
6. SUMMARY OF TEST RESULTS	13
7. SAMPLE CALCULATION.....	14
8. TEST DATA	16
8.1 EQUIVALENT ISOTROPIC RADIATED POWER (Band 41)_Primary Antenna	16
8.2 EQUIVALENT ISOTROPIC RADIATED POWER (Band 41)_Diversity Antenna	18
8.3RADIATED SPURIOUS EMISSIONS_Primary Antenna	20
8.3.1 RADIATED SPURIOUS EMISSIONS (5 MHz Band 41 LTE)	20
8.3.2 RADIATED SPURIOUS EMISSIONS (10 MHz Band 41 LTE)	21
8.3.3 RADIATED SPURIOUS EMISSIONS (15 MHz Band 41 LTE)	22
8.3.4 RADIATED SPURIOUS EMISSIONS (20 MHz Band 41 LTE)	23
8.4RADIATED SPURIOUS EMISSIONS_Diversity Antenna	24
8.4.1 RADIATED SPURIOUS EMISSIONS (5 MHz Band 41 LTE)	24
8.4.2 RADIATED SPURIOUS EMISSIONS (10 MHz Band 41 LTE)	25
8.4.3 RADIATED SPURIOUS EMISSIONS (15 MHz Band 41 LTE)	26
8.4.4 RADIATED SPURIOUS EMISSIONS (20 MHz Band 41 LTE)	27
8.5OCCUPIED BANDWIDTH	28
8.6CONDUCTED SPURIOUS EMISSIONS	29
8.6.1 BAND EDGE.....	30
8.7 FREQUENCY STABILITY / VARIATION OF AMBIENT TEMPERATURE	31
8.7.1 FREQUENCY STABILITY (5 MHz Band 41 LTE)	31
8.7.2 FREQUENCY STABILITY (10 MHz Band 41 LTE)	32
8.7.3 FREQUENCY STABILITY (15 MHz Band 41 LTE)	33
8.7.4 FREQUENCY STABILITY (20 MHz Band 41 LTE)	34
9. TEST PLOTS.....	35

MEASUREMENT REPORT

1. GENERAL INFORMATION

Applicant Name:	SAMSUNG Electronics Co., Ltd.		
Address:	129, Samsung-ro, Yeongtong-gu, Suwon-si, Gyeonggi-do, 16677, Rep. of Korea		
FCC ID:	A3LSMC5000		
Application Type:	Certification		
FCC Classification:	Licensed Portable Transmitter Held to Ear (PCE)		
FCC Rule Part(s):	§2 , §27		
EUT Type:	Mobile Phone		
FCC Model(s):	SM-C5000		
Tx Frequency:	2557.5 MHz– 2652.5 MHz (LTE – Band 41): 5 MHz 2560.0 MHz– 2650.0 MHz (LTE – Band 41): 10 MHz 2562.5 MHz– 2647.5 MHz (LTE – Band 41): 15 MHz 2565.0 MHz– 2645.0 MHz (LTE – Band 41): 20 MHz		
Max. RF Output Power:	Primary Antenna		
	Band 41 (5 MHz) :	0.163 W (QPSK) (22.13 dBm) 0.116 W (16-QAM) (20.63 dBm)	
	Band 41 (10 MHz) :	0.163 W (QPSK) (22.12 dBm) 0.119 W (16-QAM) (20.77 dBm)	
	Band 41 (15 MHz) :	0.171 W (QPSK) (22.32 dBm) 0.118 W (16-QAM) (20.73 dBm)	
	Band 41 (20 MHz) :	0.163W (QPSK) (22.13 dBm) 0.118 W (16-QAM) (20.70 dBm)	
	Diversity Antenna		
	Band 41 (5 MHz) :	0.086 W (QPSK) (19.34 dBm) 0.072 W (16-QAM) (18.55 dBm)	
	Band 41 (10 MHz) :	0.085 W (QPSK) (19.31 dBm) 0.072 W (16-QAM) (18.56 dBm)	
	Band 41 (15 MHz) :	0.085 W (QPSK) (19.30 dBm) 0.071 W (16-QAM) (18.50 dBm)	
	Band 41 (20 MHz) :	0.084 W (QPSK) (19.25 dBm) 0.070 W (16-QAM) (18.45 dBm)	
Emission Designator(s):	Band 41 (5 MHz) :	4M47G7D (QPSK) / 4M46W7D (16-QAM)	
	Band 41 (10 MHz) :	8M95G7D (QPSK) / 8M94W7D (16-QAM)	
	Band 41 (15 MHz) :	13M4G7D (QPSK) / 13M4W7D (16-QAM)	
	Band 41 (20 MHz) :	18M0G7D (QPSK) / 17M9W7D (16-QAM)	
Date(s) of Tests:	April 05, 2016 ~May 13, 2016		
Antenna Specification	Manufacturer:	SAMSUNG Electronics Co., Ltd.	
	Antenna type:	Internal Antenna	
	Peak Gain:	Primary Antenna:	Band 41 : -1.31 dBi
		Diversity Antenna:	Band 41 : -4.32 dBi

2. INTRODUCTION

2.1. EUT DESCRIPTION

The SAMSUNG Electronics Co., Ltd.SM-C5000Mobile Phone consists of LTE 41.

2.2. MEASURING INSTRUMENT CALIBRATION

The measuring equipment, which was utilized in performing the tests documented herein, has been calibrated in accordance with the manufacturer's recommendations for utilizing calibration equipment, which is traceable to recognized national standards.

2.3. TEST FACILITY

The Fully-anechoic chamber and conducted measurement facility used to collect the radiated data are located at the **74, Seoicheon-ro 578beon-gil, Majang-myeon, Icheon-si, Gyeonggi-do, 17383, Rep. of KOREA.**

3. DESCRIPTION OF TESTS

3.1 EIRP RADIATED POWER AND RADIATED SPURIOUS EMISSIONS

Note: EIRP(Equivalent Isotropic Radiated Power)

Test Procedure

Radiated emission measurements are performed in the Fully-anechoic chamber. The equipment under test is placed on a non-conductive table 3-meters away from the receive antenna in accordance with ANSI/TIA-603-D-2010 Clause 2.2.17. The turntable is rotated through 360 degrees, and the receiving antenna scans in order to determine the level of the maximized emission. The level and position of the maximized emission is recorded with the spectrum analyzer using RMS detector.

A half wave dipole is then substituted in place of the EUT. For emissions above 1GHz, a horn antenna is substituted in place of the EUT. The substitute antenna is driven by a signal generator and the previously recorded signal was duplicated.

The power is calculated by the following formula;

$$P_{d(dBm)} = P_{g(dBm)} - \text{cable loss}_{(dB)} + \text{antenna gain}_{(dB)}$$

Where: P_d is the dipole equivalent power and P_g is the generator output power into the substitution antenna.

The maximum EIRP is calculated by adding the forward power to the calibrated source plus its appropriate gain value. These steps are repeated with the receiving antenna in both vertical and horizontal polarization. the difference between the gain of the horn and an isotropic antenna are taken into consideration

Radiated spurious emissions

1. Frequency Range : 30 MHz ~ 10th Harmonics of highest channel fundamental frequency.
2. Measured distance : 30 MHz ~ 11 GHz at 3 m
11 GHz ~ 27 GHz at 1m
3. The EUT was setup to maximum output power.
4. The high, low and a middle channel were tested for out of band measurements.

3.2 OCCUPIED BANDWIDTH.

Test set-up

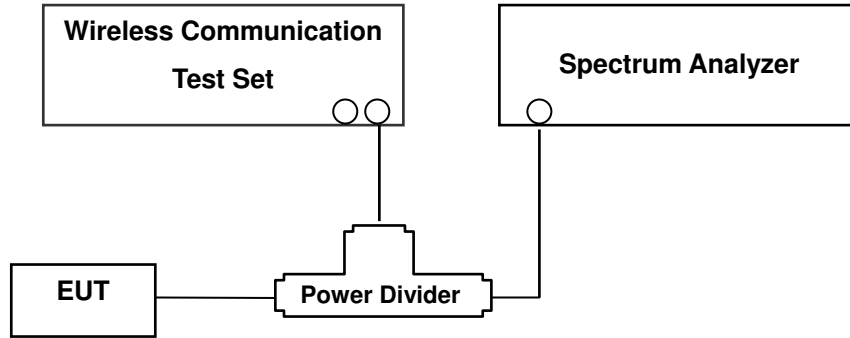

(Configuration of conducted Emission measurement)

The width of a frequency band such that, below the lower and above the upper frequency limits, the mean powers emitted are each equal to a specified percentage 0.5 % of the total mean power of a given emission.

Test Procedure

OBW is tested in accordance with KDB971168 D01 Power Meas License Digital Systems v02r02, October 17, 2014, Section 4.2.

The EUT makes a call to the communication simulator. The power was measured with R&S Spectrum Analyzer. All measurements were done at 3 channels(low, middle and high operational range.)

The conducted occupied bandwidth used the power splitter via EUT RF power connector between simulation base station and spectrum analyzer.

The communication simulator station system controlled a EUT to export maximum output power under transmission mode and specific channel frequency. Use OBW measurement function of Spectrum analyzer to measure 99 % occupied bandwidth

3.3 SPURIOUS AND HARMONIC EMISSIONS AT ANTENNA TERMINAL.

Test Procedure

Spurious and harmonic emissions at antenna terminal is tested in accordance with KDB971168 D01 Power Meas License Digital Systems v02r02, October 17, 2014, Section 6.0.

The level of the carrier and the various conducted spurious and harmonic frequencies is measured by means of a calibrated spectrum analyzer.

The EUT was setup to maximum output power. The 1 MHz RBW was used to scan from 30 MHz to 26.5 GHz. And limit is -25 dBm. The high, low and a middle channel were tested for out of band measurements.

- Channel Edge Requirement : In the 1MHz bands immediately outside and adjacent to the channel, a resolution bandwidth of at least 2% of the emission bandwidth of the fundamental emission of the transmitter may be employed to measure the out of band Emissions. Limit is -10 dBm on all frequencies between the channel edge and 5 MHz from the channel edge, -13 dBm on all frequencies between 5 MHz and X MHz from the channel edge, -25 dBm on all frequencies more than X MHz from channel edge, where X is the greater of 6 MHz or the actual emission bandwidth. In addition, the attenuation factor shall not be less than -13 dBm on all frequencies between 2490.5 MHz and 2496 MHz and -25 dBm at below 2490.5 MHz.

NOTES: The analyzer plot offsets were determined by below conditions.

- For LTE Band 41, total offset 26.9dBm = 20 dBm attenuator + 6 dBm Divider + 0.9 dBm RF cables.

3.4 FREQUENCY STABILITY / VARIATION OF AMBIENT TEMPERATURE

Test Set-up

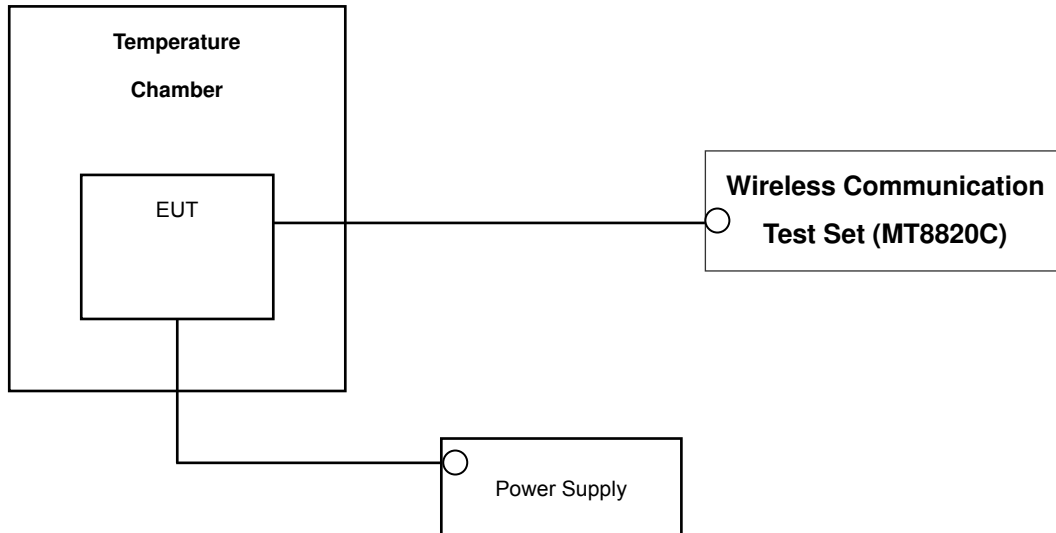

* Nominal Operating Voltage

Test Procedure

Frequency stability is tested in accordance with ANSI/TIA-603-D-2010 section 2.2.2.

The frequency stability of the transmitter is measured by:

- a.) **Temperature:** The temperature is varied from - 30 °C to + 50 °C using an environmental chamber.
- b.) **Primary Supply Voltage:** The primary supply voltage is varied from battery end point to 100 % of the voltage normally at the input to the device or at the power supply terminals if cables are not normally supplied.

Specification — the frequency stability shall be sufficient to ensure that the fundamental emission stays within the authorized frequency block.

Time Period and Procedure:

The carrier frequency of the transmitter is measured at room temperature (20°C to provide a reference).

1. The equipment is turned on in a “standby” condition for one minute before applying power to the transmitter. Measurement of the carrier frequency of the transmitter is made within one minute after applying power to the transmitter.
2. Frequency measurements are made at 10°C intervals ranging from -30°C to +50°C. A period of at least one half-hour is provided to allow stabilization of the equipment at each temperature level.

NOTE: The EUT is tested down to the battery endpoint.

4. LIST OF TEST EQUIPMENT

Manufacture	Model/ Equipment	Serial Number	Calibration Interval	Calibration Due
CERNEX	CBLU1183540B-01/ POWER AMP	25540	Annual	05/21/2016
Wainwright	WHKX 10-900-1000-15000-40SS/H.P.F	5	Annual	08/11/2016
Wainwright	WHKX10-2700-3000-18000-40SS/H.P.F	3	Annual	08/05/2016
Hewlett Packard	11667B / Power Splitter	10545	Annual	02/15/2017
Hewlett Packard	11667B / Power Splitter	11275	Annual	04/29/2017
ITECH	IT6720/ Power Supply	0100215626700119	Annual	11/02/2016
Schwarzbeck	UHAP/ Dipole Antenna	557	Biennial	03/23/2017
Schwarzbeck	UHAP/ Dipole Antenna	558	Biennial	03/23/2017
EXP	EX-TH400/ Chamber	None	Annual	05/29/2016
Schwarzbeck	BBHA 9120D/ Horn Antenna	9210D-1298	Biennial	10/16/2016
Schwarzbeck	BBHA 9120D/ Horn Antenna	9210D-1299	Biennial	10/16/2016
Schwarzbeck	BBHA 9170/ Horn Antenna(15~40GHz)	BBHA9170342	Biennial	04/30/2017
Schwarzbeck	BBHA 9170/ Horn Antenna(15~35GHz)	BBHA9170124	Biennial	04/30/2017
Agilent	N9020A/Signal Analyzer	MY52090906	Annual	05/15/2016
Hewlett Packard	8493C/ATTENUATOR	17280	Annual	06/29/2016
REOHDE&SCHWARZ	FSV40-N/Signal Analyzer	101068-SZ	Annual	09/23/2016
Agilent	8960 (E5515C)/ Base Station	MY48360800	Annual	10/30/2016
Anritsu Corp.	MT8820C/Wideband Radio Communication Tester	6200863156	Annual	02/26/2017
Anritsu Corp.	MT8820C/Wideband Radio Communication Tester	6201026545	Annual	02/16/2017
Schwarzbeck	VULB9160/ Bilog Antenna	3150	Biennial	11/17/2016
Schwarzbeck	VULB9160/ Bilog Antenna	3368	Biennial	10/10/2016

5. MEASUREMENT UNCERTAINTY

The measurement uncertainties shown below were calculated in accordance with the requirements of ANSI C63.4:2014.

All measurement uncertainty values are shown with a coverage factor of $k = 2$ to indicate a 95 % level of confidence. The measurement data shown herein meets or exceeds the U_{CISPR} measurement uncertainty values specified in CISPR 16-4-2 and, thus, can be compared directly to specified limits to determine compliance.

Parameter	Expanded Uncertainty (\pm dB)
Conducted Disturbance (150 kHz ~ 30 MHz)	1.82
Radiated Disturbance (9 kHz ~ 30 MHz)	3.40
Radiated Disturbance (30 MHz ~ 1 GHz)	4.80
Radiated Disturbance (1 GHz ~ 18 GHz)	6.07

6. SUMMARY OF TEST RESULTS

FCC Part Section(s)	Test Description	Test Limit	Test Condition	Test Result
2.1049	Occupied Bandwidth	N/A	CONDUCTED	PASS
2.1051, 27.53(m)(4)	Band Edge / Conducted Spurious Emissions.	< 40 + 10log10 (P[Watts]) at Channel edges < 43 + 10log10 (P[Watts]) between 5 and X MHz from Channel edges <55 + 10log10 (P[Watts]) beyond X MHz beyond from Channel edges		PASS
*2.1046	Conducted Output Power	N/A		PASS
2.1055, 27.54	Frequency stability	Emission must remain in band		PASS
27.50(h)(2)	Equivalent Isotropic Radiated Power	< 2 Watts max. EIRP	RADIATED	PASS
2.1053, 27.53(m)(4)	Undesirable Emissions	< 40 + 10log10 (P[Watts]) at Channel edges < 43 + 10log10 (P[Watts]) between 5 and X MHz from Channel edges <55 + 10log10 (P[Watts]) beyond X MHz beyond from Channel edges		PASS

*See SAR Report

7. SAMPLE CALCULATION

A. EIRP Sample Calculation

Mode	Ch./ Freq.		Measured Level(dBm)	Substitute LEVEL(dBm)	Ant. Gain (dBi)	C.L	Pol.	Limit	EIRP	
	channel	Freq.(MHz)						W	W	dBm
LTE Band 41	40740.0	2605.0	-25.64	7.97	11.04	1.74	H	< 2.00	0.053	17.27

EIRP = SubstituteLEVEL(dBm) + Ant. Gain – CL(Cable Loss)

- 1) The EUT mounted on a wooden tripod is 2.5 meter above test site ground level.
- 2) During the test , the turn table is rotated until the maximum signal is found.
- 3) Record the field strength meter's level.
- 4) Replace the EUT with dipole/Horn antenna that is connected to a calibrated signal generator.
- 5) Increase the signal generator output till the field strength meter's level is equal to the item (3).
- 6) The signal generator output level with Ant. Gain and cable loss are the rating of Equivalent Isotropic Radiated Power (**EIRP**).

B. Emission Designator

QPSK Modulation

5 MHz Bandwidth

Emission Designator = 4M50G7D

LTE BW = 4.50 MHz

G = Phase Modulation

7 = Quantized/Digital Info

D = Data transmission; telemetry; telecommand

10MHz Bandwidth

Emission Designator = 8M95G7D

LTE BW = 8.95 MHz

G = Phase Modulation

7 = Quantized/Digital Info

D = Data transmission; telemetry; telecommand

15MHz Bandwidth

Emission Designator = 13M5G7D

LTE BW = 13.47 MHz

G = Phase Modulation

7 = Quantized/Digital Info

D = Data transmission; telemetry; telecommand

20MHz Bandwidth

Emission Designator = 18M0G7D

LTE BW = 18.03 MHz

G = Phase Modulation

7 = Quantized/Digital Info

D = Data transmission; telemetry; telecommand

16QAM Modulation

5 MHz Bandwidth

Emission Designator = 4M51W7D

LTE BW = 4.51 MHz

W = main carrier modulated in a combination of two or more of the following modes;

amplitude, angle, pulse

7 = Quantized/Digital Info

D = Data transmission; telemetry; telecommand

10MHz Bandwidth

Emission Designator = 8M94W7D

LTE BW = 8.94 MHz

W = main carrier modulated in a combination of two or more of the following modes;

amplitude, angle, pulse

7 = Quantized/Digital Info

D = Data transmission; telemetry; telecommand

15MHz Bandwidth

Emission Designator = 13M5W7D

LTE BW = 13.47MHz

W = main carrier modulated in a combination of two or more of the following modes;

amplitude, angle, pulse

7 = Quantized/Digital Info

D = Data transmission; telemetry; telecommand

20MHz Bandwidth

Emission Designator = 18M0W7D

LTE BW = 18.03 MHz

W = main carrier modulated in a combination of two or more of the following modes;

amplitude, angle, pulse

7 = Quantized/Digital Info

D = Data transmission; telemetry; telecommand

8. TEST DATA

8.1 EQUIVALENT ISOTROPIC RADIATED POWER (Band 41)_Primary Antenna

Freq (MHz)	Bandwidth	Modulation	Measured Level (dBm)	Substitute Level (dBm)	Ant. Gain(dBi)	C.L	Pol	Limit	EIRP	
								W	W	dBm
2557.5	5 MHz	QPSK	-20.76	12.84	11.00	1.71	H	< 2.00	0.163	22.13
		16-QAM	-22.26	11.34	11.00	1.71	H		0.116	20.63
2605.0		QPSK	-23.04	9.66	11.04	1.74	H		0.079	18.96
		16-QAM	-24.61	8.09	11.04	1.74	H		0.055	17.39
2652.5		QPSK	-23.65	10.28	11.07	1.74	H		0.091	19.61
		16-QAM	-25.25	8.68	11.07	1.74	H		0.063	18.01

Equivalent Isotropic Radiated Power Data (5 MHz Band 41 LTE)

Note: All of RB size has been tested for emissions and EIRP, with the 1RB configuration observed as the worst case

Freq (MHz)	Bandwidth	Modulation	Measured Level (dBm)	Substitute Level (dBm)	Ant. Gain(dBi)	C.L	Pol	Limit	EIRP	
								W	W	dBm
2560.0	10 MHz	QPSK	-20.77	12.83	11.00	1.71	H	< 2.00	0.163	22.12
		16-QAM	-22.12	11.48	11.00	1.71	H		0.119	20.77
2605.0		QPSK	-23.08	9.62	11.04	1.74	H		0.078	18.92
		16-QAM	-24.42	8.28	11.04	1.74	H		0.057	17.58
2650.0		QPSK	-23.45	10.47	11.07	1.74	H		0.096	19.80
		16-QAM	-24.94	8.98	11.07	1.74	H		0.068	18.31

Equivalent Isotropic Radiated Power Data (10 MHz Band 41 LTE)

Note: All of RB size has been tested for emissions and EIRP, with the 1RB configuration observed as the worst case

Freq (MHz)	Bandwidth	Modulation	Measured Level (dBm)	Substitute Level (dBm)	Ant. Gain(dBi)	C.L	Pol	Limit		EIRP	
								W	W	dBm	dBm
2562.5	15 MHz	QPSK	-20.58	13.03	11.00	1.71	H	< 2.00		0.171	22.32
		16-QAM	-22.17	11.44	11.00	1.71	H			0.118	20.73
2605.0		QPSK	-22.69	10.01	11.04	1.74	H			0.085	19.31
		16-QAM	-24.31	8.39	11.04	1.74	H			0.059	17.69
2647.5		QPSK	-23.44	10.50	11.07	1.74	H			0.096	19.83
		16-QAM	-24.85	9.09	11.07	1.74	H			0.070	18.42

Equivalent Isotropic Radiated Power Data (15 MHz Band 41 LTE)

Note: All of RB size has been tested for emissions and EIRP, with the 1RB configuration observed as the worst case

Freq (MHz)	Bandwidth	Modulation	Measured Level (dBm)	Substitute Level (dBm)	Ant. Gain(dBi)	C.L	Pol	Limit		EIRP	
								W	W	dBm	dBm
2565.0	20 MHz	QPSK	-20.78	12.83	11.01	1.71	H	< 2.00		0.163	22.13
		16-QAM	-22.21	11.40	11.01	1.71	H			0.118	20.70
2605.0		QPSK	-22.83	9.87	11.04	1.74	H			0.083	19.17
		16-QAM	-24.30	8.40	11.04	1.74	H			0.059	17.70
2645.0		QPSK	-23.30	10.67	11.07	1.74	H			0.100	20.00
		16-QAM	-24.73	9.24	11.07	1.74	H			0.072	18.57

Equivalent Isotropic Radiated Power Data (20 MHz Band 41 LTE)

Note: All of RB size has been tested for emissions and EIRP, with the 1RB configuration observed as the worst case

NOTES:

Equivalent Isotropic Radiated Power Measurements by Substitution Method

according to ANSI/TIA/EIA-603-D-2010 June 24, 2010:

The EUT was placed on a non-conductive styrofoam resin table 3-meters from the receive antenna. Turntable rotation was adjusted for the highest reading on the receive spectrum analyzer. For LTE signals, RBW = 1-5% of the OBW, not to exceed 1MHz, VBW ≥ 3 x RBW, Detector = RMS. A Horn antenna was substituted in place of the EUT. This Horn antenna was driven by a signal generator and the level of the signal generator was adjusted to obtain the same receive spectrum analyzer reading. The conducted power at the terminals of the Horn antenna is measured. The difference between the gain of the horn and an isotropic antenna is taken into consideration and the EIRP is recorded.

Also, we have done x, y, z planes in EUT and horizontal and vertical polarization in detecting antenna. The worst case of the EUT is x plane in LTE mode. Also worst case of detecting Antenna is horizontal polarization in LTE mode.

8.2 EQUIVALENT ISOTROPIC RADIATED POWER (Band 41)_Diversity Antenna

Freq (MHz)	Bandwidth	Modulation	Measured Level (dBm)	Substitute Level (dBm)	Ant. Gain(dBi)	C.L	Pol	Limit	EIRP	
								W	W	dBm
2557.5	5 MHz	QPSK	-23.55	10.05	11.00	1.71	H	< 2.00	0.086	19.34
		16-QAM	-24.34	9.26	11.00	1.71	H		0.072	18.55
2605.0		QPSK	-25.88	6.82	11.04	1.74	H		0.041	16.12
		16-QAM	-27.43	5.27	11.04	1.74	H		0.029	14.57
2652.5		QPSK	-26.79	7.14	11.07	1.74	H		0.044	16.47
		16-QAM	-28.29	5.64	11.07	1.74	H		0.031	14.97

Equivalent Isotropic Radiated Power Data (5 MHz Band 41 LTE)

Note: All of RB size has been tested for emissions and EIRP, with the 1RB configuration observed as the worst case

Freq (MHz)	Bandwidth	Modulation	Measured Level (dBm)	Substitute Level (dBm)	Ant. Gain(dBi)	C.L	Pol	Limit	EIRP	
								W	W	dBm
2560.0	10 MHz	QPSK	-23.58	10.02	11.00	1.71	H	< 2.00	0.085	19.31
		16-QAM	-24.33	9.27	11.00	1.71	H		0.072	18.56
2605.0		QPSK	-25.54	7.16	11.04	1.74	H		0.044	16.46
		16-QAM	-26.96	5.74	11.04	1.74	H		0.032	15.04
2650.0		QPSK	-27.08	6.84	11.07	1.74	H		0.041	16.17
		16-QAM	-28.52	5.40	11.07	1.74	H		0.030	14.73

Equivalent Isotropic Radiated Power Data (10 MHz Band 41 LTE)

Note: All of RB size has been tested for emissions and EIRP, with the 1RB configuration observed as the worst case

Freq (MHz)	Bandwidth	Modulation	Measured Level (dBm)	Substitute Level (dBm)	Ant. Gain(dBi)	C.L	Pol	Limit		EIRP	
								W	W	dBm	
2562.5	15 MHz	QPSK	-23.60	10.01	11.00	1.71	H	< 2.00		0.085	19.30
		16-QAM	-24.40	9.21	11.00	1.71	H			0.071	18.50
2605.0		QPSK	-24.83	7.87	11.04	1.74	H			0.052	17.17
		16-QAM	-26.35	6.35	11.04	1.74	H			0.037	15.65
2647.5		QPSK	-28.05	5.89	11.07	1.74	H			0.033	15.22
		16-QAM	-28.89	5.05	11.07	1.74	H			0.027	14.38

Equivalent Isotropic Radiated Power Data (15 MHz Band 41 LTE)

Note: All of RB size has been tested for emissions and EIRP, with the 1RB configuration observed as the worst case

Freq (MHz)	Bandwidth	Modulation	Measured Level (dBm)	Substitute Level (dBm)	Ant. Gain(dBi)	C.L	Pol	Limit		EIRP	
								W	W	dBm	
2565.0	20 MHz	QPSK	-23.66	9.95	11.01	1.71	H	< 2.00		0.084	19.25
		16-QAM	-24.46	9.15	11.01	1.71	H			0.070	18.45
2605.0		QPSK	-24.66	8.04	11.04	1.74	H			0.054	17.34
		16-QAM	-25.99	6.71	11.04	1.74	H			0.040	16.01
2645.0		QPSK	-28.26	5.71	11.07	1.74	H			0.032	15.04
		16-QAM	-29.14	4.83	11.07	1.74	H			0.026	14.16

Equivalent Isotropic Radiated Power Data (20 MHz Band 41 LTE)

Note: All of RB size has been tested for emissions and EIRP, with the 1RB configuration observed as the worst case

NOTES:

Equivalent Isotropic Radiated Power Measurements by Substitution Method

according to ANSI/TIA/EIA-603-D-2010 June 24, 2010:

The EUT was placed on a non-conductive styrofoam resin table 3-meters from the receive antenna. Turntable rotation was adjusted for the highest reading on the receive spectrum analyzer. For LTE signals, RBW = 1-5% of the OBW, not to exceed 1MHz, VBW ≥ 3 x RBW, Detector = RMS. A Horn antenna was substituted in place of the EUT. This Horn antenna was driven by a signal generator and the level of the signal generator was adjusted to obtain the same receive spectrum analyzer reading. The conducted power at the terminals of the Horn antenna is measured. The difference between the gain of the horn and an isotropic antenna is taken into consideration and the EIRP is recorded.

Also, we have done x, y, z planes in EUT and horizontal and vertical polarization in detecting antenna. The worst case of the EUT is x plane in LTE mode. Also worst case of detecting Antenna is horizontal polarization in LTE mode.

8.3 RADIATED SPURIOUS EMISSIONS_Primary Antenna

8.3.1 RADIATED SPURIOUS EMISSIONS (5 MHz Band 41 LTE)

- ▣ OPERATING FREQUENCY : 2557.50 MHz
- ▣ MEASURED OUTPUT POWER: 22.13 dBm = 0.163 W
- ▣ MODULATION SIGNAL: 5 MHz QPSK
- ▣ DISTANCE: 3 meters
- ▣ LIMIT: $55 + 10 \log_{10}(W) =$ 47.13dBc

Ch	Freq (MHz)	Measured Level (dBm)	Ant. Gain (dBi)	Substitute Level (dBm)	C.L	Pol	EIRP (dBm)	dBc
40265.0 (2557.5)	5,115.00	-48.61	13.57	-53.68	2.43	V	-42.54	64.67
	7,672.50	-52.06	11.94	-50.77	2.95	H	-41.78	63.91
	10,230.00	-46.25	11.76	-38.83	3.66	V	-30.73	52.86
40740.0 (2605.0)	5,210.00	-49.64	13.72	-54.79	2.45	H	-43.52	65.65
	7,815.00	-59.42	11.76	-57.25	3.07	V	-48.56	70.69
	10,420.00	-51.33	11.68	-42.91	3.64	H	-34.87	57.00
41215.0 (2652.5)	5,305.00	-48.33	13.87	-53.84	2.47	H	-42.44	64.57
	7,957.50	-60.47	11.57	-57.59	3.00	V	-49.02	71.15
	10,610.00	-51.44	11.61	-42.51	3.77	H	-34.67	56.80

- NOTES:**
1. Radiated Spurious Emission Measurements at 1 meter and 3 meters by Substitution Method according to ANSI/TIA/EIA-603-D-2010 June 24, 2010:
 2. We are performed all frequency to 10th harmonics from 30 MHz. Measurements above show only up to 3 maximum emissions noted, or would be lesser if no specific emissions from the EUT are recorded (ie: margin > 20 dB from the applicable limit) and considered that's already beyond the background noise floor.
 3. We have done x, y, z planes in EUT and horizontal and vertical polarization in detecting antenna.
 4. All of RB size has been tested for emissions and EIRP, with the 1RB configuration observed as the worst case
 5. We are performed 16QAM and QPSK modulations. The worst case data are reported in the table above.

8.3.2 RADIATED SPURIOUS EMISSIONS (10 MHz Band 41 LTE)

- ▣ OPERATING FREQUENCY : 2560.00 MHz
- ▣ MEASURED OUTPUT POWER: 22.12 dBm = 0.163 W
- ▣ MODULATION SIGNAL: 10 MHz QPSK
- ▣ DISTANCE: 3 meters
- ▣ LIMIT: $55 + 10 \log_{10}(W) =$ 47.12dBc

Ch	Freq (MHz)	Measured Level (dBm)	Ant. Gain (dBi)	Substitute Level (dBm)	C.L	Pol	EIRP (dBm)	dBc
40290.0 (2560.0)	5,120.00	-48.07	13.58	-53.16	2.43	H	-42.01	64.13
	7,680.00	-52.21	11.93	-50.60	2.97	V	-41.64	63.76
	10,240.00	-46.72	11.76	-39.41	3.49	V	-31.14	53.26
40740.0 (2605.0)	5,210.00	-50.24	13.72	-55.39	2.45	H	-44.12	66.24
	7,815.00	-59.09	11.76	-56.92	3.07	H	-48.23	70.35
	10,420.00	-51.94	11.68	-43.52	3.64	V	-35.48	57.60
41190.0 (2650.0)	5,300.00	-49.76	13.86	-55.27	2.47	H	-43.88	66.00
	7,950.00	-59.13	11.59	-56.46	3.02	V	-47.89	70.01
	10,600.00	-51.23	11.61	-42.30	3.77	H	-34.46	56.58

- NOTES:**
1. Radiated Spurious Emission Measurements at 1 meter and 3 meters by Substitution Method according to ANSI/TIA/EIA-603-D-2010 June 24, 2010:
 2. We are performed all frequency to 10th harmonics from 30 MHz. Measurements above show only up to 3 maximum emissions noted, or would be lesser if no specific emissions from the EUT are recorded (ie: margin > 20 dB from the applicable limit) and considered that's already beyond the background noise floor.
 3. We have done x, y, z planes in EUT and horizontal and vertical polarization in detecting antenna.
 4. All of RB size has been tested for emissions and EIRP, with the 1RB configuration observed as the worst case
 5. We are performed 16QAM and QPSK modulations. The worst case data are reported in the table above.

8.3.3 RADIATED SPURIOUS EMISSIONS (15 MHz Band 41 LTE)

- ▣ OPERATING FREQUENCY : 2562.50 MHz
- ▣ MEASURED OUTPUT POWER: 22.32 dBm = 0.171 W
- ▣ MODULATION SIGNAL: 15 MHz QPSK
- ▣ DISTANCE: 3 meters
- ▣ LIMIT: $55 + 10 \log_{10}(W) =$ 47.32dBc

Ch	Freq (MHz)	Measured Level (dBm)	Ant. Gain (dBi)	Substitute Level (dBm)	C.L	Pol	EIRP (dBm)	dBc
40315.0 (2562.5)	5,125.00	-47.68	13.59	-52.61	2.44	H	-41.46	63.78
	7,687.50	-51.68	11.92	-50.03	3.00	V	-41.11	63.43
	10,250.00	-47.77	11.75	-40.33	3.48	H	-32.06	54.38
40740.0 (2605.0)	5,210.00	-50.35	13.72	-55.50	2.45	H	-44.23	66.55
	7,815.00	-58.42	11.76	-56.25	3.07	V	-47.56	69.88
	10,420.00	-51.58	11.68	-43.16	3.64	H	-35.12	57.44
41165.0 (2647.5)	5,295.00	-50.73	13.85	-56.19	2.48	H	-44.82	67.14
	7,942.50	-59.90	11.60	-57.00	3.02	V	-48.42	70.74
	10,590.00	-52.14	11.61	-42.91	3.71	H	-35.01	57.33

- NOTES:**
1. Radiated Spurious Emission Measurements at 1 meter and 3 meters by Substitution Method according to ANSI/TIA/EIA-603-D-2010 June 24, 2010:
 2. We are performed all frequency to 10th harmonics from 30 MHz. Measurements above show only up to 3 maximum emissions noted, or would be lesser if no specific emissions from the EUT are recorded (ie: margin > 20 dB from the applicable limit) and considered that's already beyond the background noise floor.
 3. We have done x, y, z planes in EUT and horizontal and vertical polarization in detecting antenna.
 4. All of RB size has been tested for emissions and EIRP, with the 1RB configuration observed as the worst case
 5. We are performed 16QAM and QPSK modulations. The worst case data are reported in the table above.

8.3.4 RADIATED SPURIOUS EMISSIONS (20 MHz Band 41 LTE)

- ▣ OPERATING FREQUENCY : 2565.00 MHz
- ▣ MEASURED OUTPUT POWER: 22.13 dBm = 0.163 W
- ▣ MODULATION SIGNAL: 20 MHz QPSK
- ▣ DISTANCE: 3 meters
- ▣ LIMIT: $55 + 10 \log_{10}(W) =$ 47.13dBc

Ch	Freq (MHz)	Measured Level (dBm)	Ant. Gain (dBi)	Substitute Level (dBm)	C.L	Pol	EIRP (dBm)	dBc
40340.0 (2565.0)	5,130.00	-48.10	13.60	-52.87	2.44	V	-41.71	63.84
	7,695.00	-52.05	11.92	-50.15	3.02	V	-41.25	63.38
	10,260.00	-46.04	11.75	-39.14	3.48	H	-30.87	53.00
40740.0 (2605.0)	5,210.00	-52.36	13.72	-57.51	2.45	H	-46.24	68.37
	7,815.00	-57.26	11.76	-55.09	3.07	V	-46.40	68.53
	10,420.00	-51.73	11.68	-43.31	3.64	V	-35.27	57.40
41140.0 (2645.0)	5,290.00	-50.13	13.84	-55.55	2.48	H	-44.19	66.32
	7,935.00	-57.43	11.61	-54.36	3.02	V	-45.77	67.90
	10,580.00	-51.29	11.61	-41.79	3.81	V	-33.99	56.12

- NOTES:**
1. Radiated Spurious Emission Measurements at 1 meter and 3 meters by Substitution Method according to ANSI/TIA/EIA-603-D-2010 June 24, 2010:
 2. We are performed all frequency to 10th harmonics from 30 MHz. Measurements above show only up to 3 maximum emissions noted, or would be lesser if no specific emissions from the EUT are recorded (ie: margin > 20 dB from the applicable limit) and considered that's already beyond the background noise floor.
 3. We have done x, y, z planes in EUT and horizontal and vertical polarization in detecting antenna.
 4. All of RB size has been tested for emissions and EIRP, with the 1RB configuration observed as the worst case
 5. We are performed 16QAM and QPSK modulations. The worst case data are reported in the table above.

8.4 RADIATED SPURIOUS EMISSIONS_Diversity Antenna

8.4.1 RADIATED SPURIOUS EMISSIONS (5 MHz Band 41 LTE)

- ▣ OPERATING FREQUENCY : 2557.50 MHz
- ▣ MEASURED OUTPUT POWER: 19.34 dBm = 0.086 W
- ▣ MODULATION SIGNAL: 5 MHz QPSK
- ▣ DISTANCE: 3 meters
- ▣ LIMIT: $55 + 10 \log_{10}(W) =$ 44.34 dBc

Ch	Freq (MHz)	Measured Level (dBm)	Ant. Gain (dBi)	Substitute Level (dBm)	C.L	Pol	EIRP (dBm)	dBc
40265.0 (2557.5)	5,115.00	-51.79	13.57	-56.86	2.43	V	-45.72	65.06
	7,672.50	-54.44	11.94	-53.15	2.95	V	-44.16	63.50
	10,230.00	-51.64	11.76	-44.22	3.66	H	-36.12	55.46
40740.0 (2605.0)	5,210.00	-60.14	13.72	-65.29	2.45	H	-54.02	73.36
	7,815.00	-63.18	11.76	-61.01	3.07	H	-52.32	71.66
	10,420.00	-53.34	11.68	-44.92	3.64	H	-36.88	56.22
41215.0 (2652.5)	5,305.00	-43.07	13.87	-48.58	2.47	H	-37.18	56.52
	7,957.50	-59.94	11.57	-57.06	3.00	V	-48.49	67.83
	10,610.00	-49.33	11.61	-40.40	3.77	H	-32.56	51.90

- NOTES:**
1. Radiated Spurious Emission Measurements at 1 meter and 3 meters by Substitution Method according to ANSI/TIA/EIA-603-D-2010 June 24, 2010:
 2. We are performed all frequency to 10th harmonics from 30 MHz. Measurements above show only up to 3 maximum emissions noted, or would be lesser if no specific emissions from the EUT are recorded (ie: margin > 20 dB from the applicable limit) and considered that's already beyond the background noise floor.
 3. We have done x, y, z planes in EUT and horizontal and vertical polarization in detecting antenna.
 4. All of RB size has been tested for emissions and EIRP, with the 1RB configuration observed as the worst case
 5. We are performed 16QAM and QPSK modulations. The worst case data are reported in the table above.

8.4.2 RADIATED SPURIOUS EMISSIONS (10 MHz Band 41 LTE)

- ▣ OPERATING FREQUENCY : 2560.00 MHz
- ▣ MEASURED OUTPUT POWER: 19.31 dBm = 0.085 W
- ▣ MODULATION SIGNAL: 10 MHz QPSK
- ▣ DISTANCE: 3 meters
- ▣ LIMIT: $55 + 10 \log_{10}(W) =$ 44.31 dBc

Ch	Freq (MHz)	Measured Level (dBm)	Ant. Gain (dBi)	Substitute Level (dBm)	C.L	Pol	EIRP (dBm)	dBc
40290.0 (2560.0)	5,120.00	-51.63	13.58	-56.72	2.43	V	-45.57	64.88
	7,680.00	-55.43	11.93	-53.82	2.97	H	-44.86	64.17
	10,240.00	-50.11	11.76	-42.80	3.49	H	-34.53	53.84
40740.0 (2605.0)	5,210.00	-56.91	13.72	-62.06	2.45	V	-50.79	70.10
	7,815.00	-63.35	11.76	-61.18	3.07	H	-52.49	71.80
	10,420.00	-51.14	11.68	-42.72	3.64	H	-34.68	53.99
41190.0 (2650.0)	5,300.00	-49.43	13.86	-54.94	2.47	H	-43.55	62.86
	7,950.00	-63.07	11.59	-60.40	3.02	H	-51.83	71.14
	10,600.00	-53.03	11.61	-44.10	3.77	H	-36.26	55.57

- NOTES:**
1. Radiated Spurious Emission Measurements at 1 meter and 3 meters by Substitution Method according to ANSI/TIA/EIA-603-D-2010 June 24, 2010:
 2. We are performed all frequency to 10th harmonics from 30 MHz. Measurements above show only up to 3 maximum emissions noted, or would be lesser if no specific emissions from the EUT are recorded (ie: margin > 20 dB from the applicable limit) and considered that's already beyond the background noise floor.
 3. We have done x, y, z planes in EUT and horizontal and vertical polarization in detecting antenna.
 4. All of RB size has been tested for emissions and EIRP, with the 1RB configuration observed as the worst case
 5. We are performed 16QAM and QPSK modulations. The worst case data are reported in the table above.

8.4.3 RADIATED SPURIOUS EMISSIONS (15 MHz Band 41 LTE)

- ▣ OPERATING FREQUENCY : 2562.50 MHz
- ▣ MEASURED OUTPUT POWER: 19.30 dBm = 0.085 W
- ▣ MODULATION SIGNAL: 15 MHz QPSK
- ▣ DISTANCE: 3 meters
- ▣ LIMIT: $55 + 10 \log_{10}(W) =$ 44.30 dBc

Ch	Freq (MHz)	Measured Level (dBm)	Ant. Gain (dBi)	Substitute Level (dBm)	C.L	Pol	EIRP (dBm)	dBc
40315.0 (2562.5)	5,125.00	-52.04	13.59	-56.97	2.44	V	-45.82	65.12
	7,687.50	-56.48	11.92	-54.83	3.00	V	-45.91	65.21
	10,250.00	-51.64	11.75	-44.20	3.48	H	-35.93	55.23
40740.0 (2605.0)	5,210.00	-53.44	13.72	-58.59	2.45	V	-47.32	66.62
	7,815.00	-62.06	11.76	-59.89	3.07	H	-51.20	70.50
	10,420.00	-50.92	11.68	-42.50	3.64	H	-34.46	53.76
41165.0 (2647.5)	5,295.00	-43.91	13.85	-49.37	2.48	V	-38.00	57.30
	7,942.50	-62.86	11.60	-59.96	3.02	H	-51.38	70.68
	10,590.00	-51.08	11.61	-41.85	3.71	H	-33.95	53.25

- NOTES:**
1. Radiated Spurious Emission Measurements at 1 meter and 3 meters by Substitution Method according to ANSI/TIA/EIA-603-D-2010 June 24, 2010:
 2. We are performed all frequency to 10th harmonics from 30 MHz. Measurements above show only up to 3 maximum emissions noted, or would be lesser if no specific emissions from the EUT are recorded (ie: margin > 20 dB from the applicable limit) and considered that's already beyond the background noise floor.
 3. We have done x, y, z planes in EUT and horizontal and vertical polarization in detecting antenna.
 4. All of RB size has been tested for emissions and EIRP, with the 1RB configuration observed as the worst case
 5. We are performed 16QAM and QPSK modulations. The worst case data are reported in the table above.

8.4.4 RADIATED SPURIOUS EMISSIONS (20 MHz Band 41 LTE)

- ▣ OPERATING FREQUENCY : 2565.00 MHz
- ▣ MEASURED OUTPUT POWER: 19.25 dBm = 0.084 W
- ▣ MODULATION SIGNAL: 20 MHz QPSK
- ▣ DISTANCE: 3 meters
- ▣ LIMIT: $55 + 10 \log_{10}(W) =$ 44.25 dBc

Ch	Freq (MHz)	Measured Level (dBm)	Ant. Gain (dBi)	Substitute Level (dBm)	C.L	Pol	EIRP (dBm)	dBc
40340.0 (2565.0)	5,130.00	-55.47	13.60	-60.24	2.44	V	-49.08	68.33
	7,695.00	-54.53	11.92	-52.63	3.02	V	-43.73	62.98
	10,260.00	-46.54	11.75	-39.64	3.48	H	-31.37	50.62
40740.0 (2605.0)	5,210.00	-44.84	13.72	-49.99	2.45	V	-38.72	57.97
	7,815.00	-55.34	11.76	-53.17	3.07	V	-44.48	63.73
	10,420.00	-47.82	11.68	-39.40	3.64	H	-31.36	50.61
41140.0 (2645.0)	5,290.00	-44.63	13.84	-50.05	2.48	V	-38.69	57.94
	7,935.00	-61.19	11.61	-58.12	3.02	V	-49.53	68.78
	10,580.00	-48.35	11.61	-38.85	3.81	H	-31.05	50.30

- NOTES:**
1. Radiated Spurious Emission Measurements at 1 meter and 3 meters by Substitution Method according to ANSI/TIA/EIA-603-D-2010 June 24, 2010:
 2. We are performed all frequency to 10th harmonics from 30 MHz. Measurements above show only up to 3 maximum emissions noted, or would be lesser if no specific emissions from the EUT are recorded (ie: margin > 20 dB from the applicable limit) and considered that's already beyond the background noise floor.
 3. We have done x, y, z planes in EUT and horizontal and vertical polarization in detecting antenna.
 4. All of RB size has been tested for emissions and EIRP, with the 1RB configuration observed as the worst case
 5. We are performed 16QAM and QPSK modulations. The worst case data are reported in the table above.

8.5 OCCUPIED BANDWIDTH

Band	Band Width	Frequency (MHz)	Modulation	Resource Block Size	Resource Block Offset	Data (dB)
41	5 MHz	2605.0	QPSK	25	0	4.4702
			16-QAM	25	0	4.4602
	10 MHz	2605.0	QPSK	50	0	8.9462
			16-QAM	50	0	8.9394
	15 MHz	2605.0	QPSK	75	0	13.4200
			16-QAM	75	0	13.4210
	20 MHz	2605.0	QPSK	100	0	17.9860
			16-QAM	100	0	17.8770

- Plots of the EUT's Occupied Bandwidth are shown Page 36 ~39.

8.6 CONDUCTED SPURIOUS EMISSIONS

■ FACTORS FOR FREQUENCY

Frequency Range (GHz)	Factor [dB]
0.03 – 1	27.145
1 – 5	26.960
5 – 10	27.542
10 – 15	28.439
15 – 20	29.144
Above 20	30.148

NOTES:

Factor(dB) = Cable Loss + Attenuator + Power Splitter

Band	Band Width (MHz)	Frequency (MHz)	Frequency of Maximum Harmonic (GHz)	Factor (dB)	Measurement Maximum Data (dBm)	Result (dBm)	Limit (dBm)
41	5	2557.5	26.1766	30.148	-68.919	-38.771	-25.00
		2605.0	5.2064	27.542	-65.721	-38.179	
		2652.5	5.3011	27.542	-65.641	-38.099	
	10	2560.0	5.1117	27.542	-68.849	-41.307	
		2605.0	5.2019	27.542	-64.699	-37.157	
		2650.0	5.2917	27.542	-65.062	-37.520	
	15	2562.5	5.1122	27.542	-69.250	-41.708	
		2605.0	5.1975	27.542	-64.857	-37.315	
		2647.5	5.2822	27.542	-60.074	-32.532	
	20	2565.0	5.1127	27.542	-69.135	-41.593	
		2605.0	5.1930	27.542	-64.753	-37.211	
		2645.0	26.1106	30.148	-68.216	-38.068	

NOTES:

1. Conducted Spurious Emissions was Tested QPSK Modulation, Resource Block Size 1 and Resource Block Offset 0
2. Result (dBm) = Measurement Maximum Data (dBm) + Factor (dB)

- Plots of the EUT's Conducted Spurious Emissions are shown Page 46 ~ 57.

8.6.1 BAND EDGE

Band	Band Width (MHz)	Frequency (MHz)	Modulation	Resource Block Size	Resource Block Offset	Channel Edge Data [dBm]					
						Channel Edge (Limit: -10 dBm)		5MHz ~ X MHz from the Channel Edge (Limit: -13 dBm)		X MHz ~ from the Channel Edge (Limit: -25 dBm)	
						Lower	Upper	Lower	Upper	Lower	Upper
41	5	2557.5	QPSK	25	0	-19.87	-17.78	-29.97	-29.76	-32.14	-31.03
		2605.0		25	0	-18.45	-17.56	-31.27	-31.42	-33.39	-32.77
		2652.5		25	0	-18.15	-16.55	-29.94	-32.09	-31.66	-33.28
	10	2560.0		50	0	-20.98	-20.16	-26.81	-22.86	-34.67	-33.06
		2605.0		50	0	-20.96	-19.9	-24.54	-22.81	-34.15	-34.42
		2650.0		50	0	-20.5	-18.92	-23.29	-22.25	-31.78	-35.94
	15	2562.5		75	0	-24.24	-20.83	-28.88	-22.87	-40.48	-36.46
		2605.0		75	0	-22.64	-20.85	-25.02	-23.38	-36.87	-37.82
		2647.5		75	0	-22.13	-19.6	-23.38	-22.18	-32.65	-39.16
	20	2565.0		100	0	-26.16	-22.76	-30.81	-23.28	-45.98	-35.97
		2605.0		100	0	-24.13	-21.57	-26.98	-24.34	-38.46	-40.13
		2645.0		100	0	-24.57	-21.29	-25.91	-23.22	-33.82	-44.15

- Plots of the EUT's Band Edge are shown Page 40 ~ 45.

8.7 FREQUENCY STABILITY / VARIATION OF AMBIENT TEMPERATURE

8.7.1 FREQUENCY STABILITY (5 MHz Band 41 LTE)

- ▣ OPERATING FREQUENCY: 2605.000,000 Hz
- ▣ CHANNEL: 40740 (5 MHz)
- ▣ REFERENCE VOLTAGE: 3.85 VDC
- ▣ DEVIATION LIMIT: Emission must remain in band

Voltage (%)	Power (VDC)	Temp. (°C)	Frequency (Hz)	Frequency Error (Hz)	Deviation (%)	ppm
100%	3.85	+20(Ref)	2605 000 003	0.0	0.000 000	0.0000
100%		-30	2605 000 008	5.1	0.000 000	0.0020
100%		-20	2605 000 010	6.7	0.000 000	0.0026
100%		-10	2604 999 998	-5.5	0.000 000	-0.0021
100%		0	2605 000 009	5.5	0.000 000	0.0021
100%		+10	2604 999 997	-6.6	0.000 000	-0.0025
100%		+30	2605 000 014	11.1	0.000 000	0.0043
100%		+40	2604 999 997	-6.4	0.000 000	-0.0025
100%		+50	2604 999 997	-6.5	0.000 000	-0.0025
Batt. Endpoint	3.60	+20	2604 999 997	-6.0	0.000 000	-0.0023

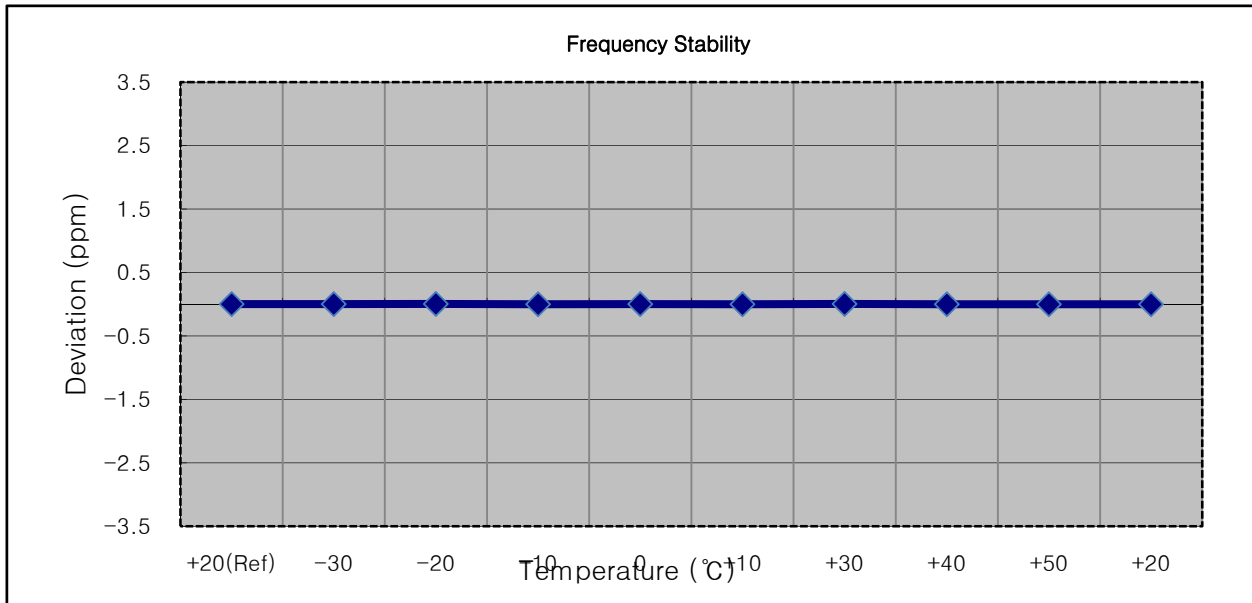

8.7.2 FREQUENCY STABILITY (10 MHz Band 41 LTE)

- ▣ OPERATING FREQUENCY: 2605.000,000 Hz
- ▣ CHANNEL: 40740 (10 MHz)
- ▣ REFERENCE VOLTAGE: 3.85 VDC
- ▣ DEVIATION LIMIT: Emission must remain in band

Voltage (%)	Power (VDC)	Temp. (°C)	Frequency (Hz)	Frequency Error (Hz)	Deviation (%)	ppm
100%	3.85	+20(Ref)	2605 000 004	0.0	0.000 000	0.0000
100%		-30	2604 999 998	-6.4	0.000 000	-0.0025
100%		-20	2605 000 011	7.1	0.000 000	0.0027
100%		-10	2604 999 999	-5.3	0.000 000	-0.0020
100%		0	2604 999 996	-7.8	0.000 000	-0.0030
100%		+10	2605 000 012	8.2	0.000 000	0.0031
100%		+30	2604 999 997	-7.4	0.000 000	-0.0028
100%		+40	2605 000 012	8.2	0.000 000	0.0031
100%		+50	2604 999 998	-6.1	0.000 000	-0.0023
Batt. Endpoint	3.60	+20	2604 999 996	-7.9	0.000 000	-0.0030

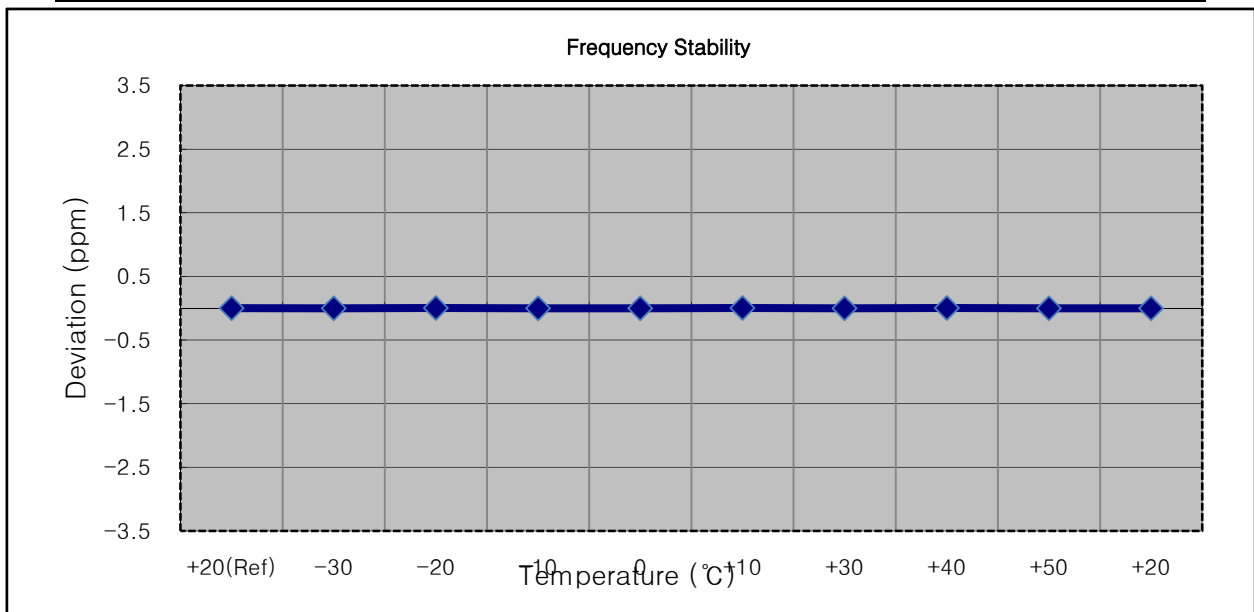

8.7.3 FREQUENCY STABILITY (15 MHz Band 41 LTE)

- ▣ OPERATING FREQUENCY: 2605.000,000 Hz
- ▣ CHANNEL: 40740 (15 MHz)
- ▣ REFERENCE VOLTAGE: 3.85 VDC
- ▣ DEVIATION LIMIT: Emission must remain in band

Voltage (%)	Power (VDC)	Temp. (°C)	Frequency (Hz)	Frequency Error (Hz)	Deviation (%)	ppm
100%	3.85	+20(Ref)	2605 000 006	0.0	0.000 000	0.000
100%		-30	2605 000 011	5.3	0.000 000	0.002
100%		-20	2604 999 996	-9.8	0.000 000	-0.004
100%		-10	2605 000 012	5.8	0.000 000	0.002
100%		0	2605 000 002	-3.7	0.000 000	-0.001
100%		+10	2605 000 017	10.8	0.000 000	0.004
100%		+30	2605 000 000	-6.3	0.000 000	-0.002
100%		+40	2605 000 012	6.2	0.000 000	0.002
100%		+50	2605 000 012	5.9	0.000 000	0.002
Batt. Endpoint	3.60	+20	2604 999 998	-7.9	0.000 000	-0.003

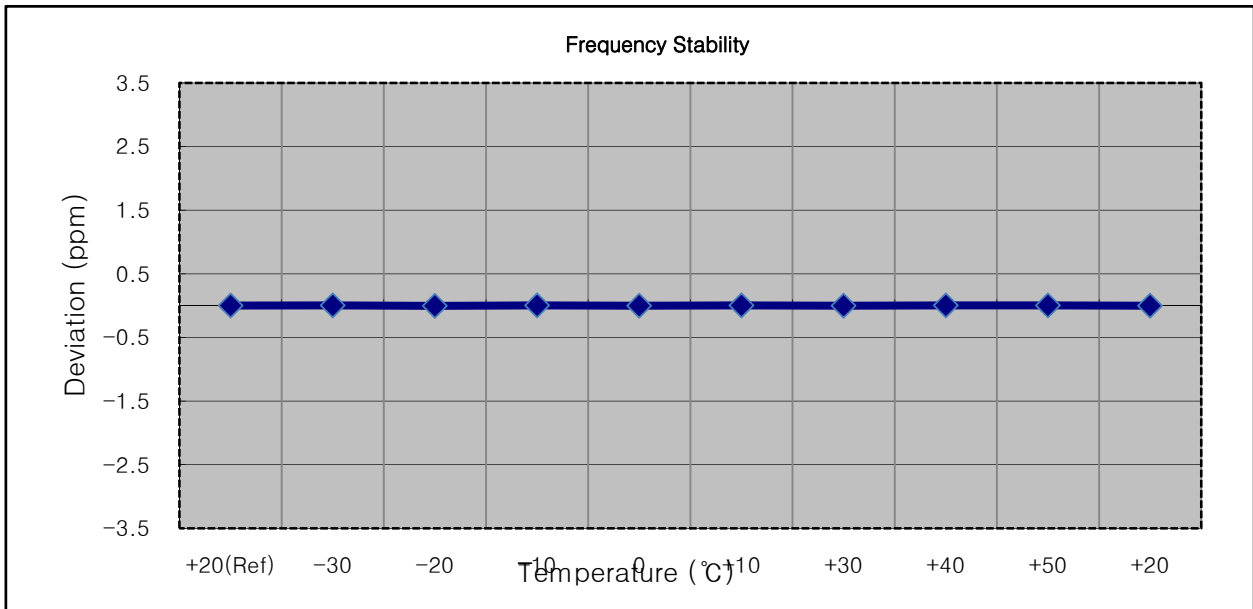

8.7.4 FREQUENCY STABILITY (20 MHz Band 41 LTE)

- ▣ OPERATING FREQUENCY: 2605.000,000 Hz
- ▣ CHANNEL: 40740 (20 MHz)
- ▣ REFERENCE VOLTAGE: 3.85 VDC
- ▣ DEVIATION LIMIT: Emission must remain in band

Voltage (%)	Power (VDC)	Temp. (°C)	Frequency (Hz)	Frequency Error (Hz)	Deviation (%)	ppm
100%	3.85	+20(Ref)	2605 000 008	0.0	0.000 000	0.000
100%		-30	2605 000 001	-6.5	0.000 000	-0.002
100%		-20	2605 000 014	6.6	0.000 000	0.003
100%		-10	2605 000 016	8.5	0.000 000	0.003
100%		0	2605 000 014	6.2	0.000 000	0.002
100%		+10	2605 000 002	-6.1	0.000 000	-0.002
100%		+30	2605 000 016	8.4	0.000 000	0.003
100%		+40	2605 000 014	6.3	0.000 000	0.002
100%		+50	2605 000 017	8.9	0.000 000	0.003
Batt. Endpoint	3.60	+20	2605 000 004	-4.3	0.000 000	-0.002

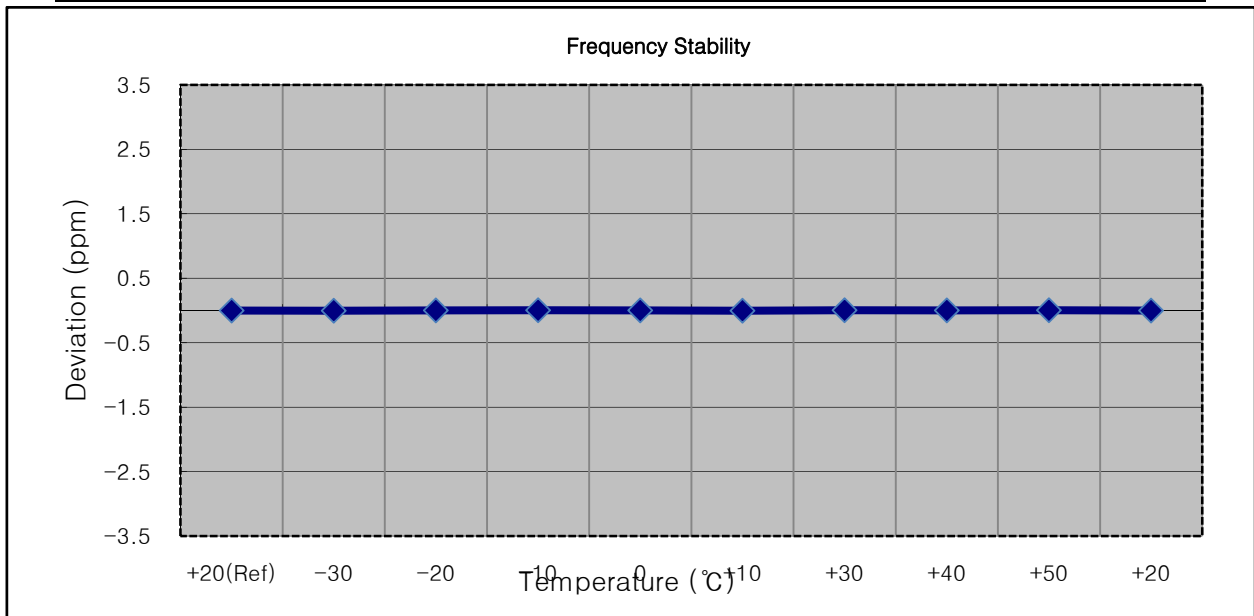

9. TEST PLOTS

BAND 41. Occupied Bandwidth Plot (5 MHz Ch.40740 QPSK RB 25)

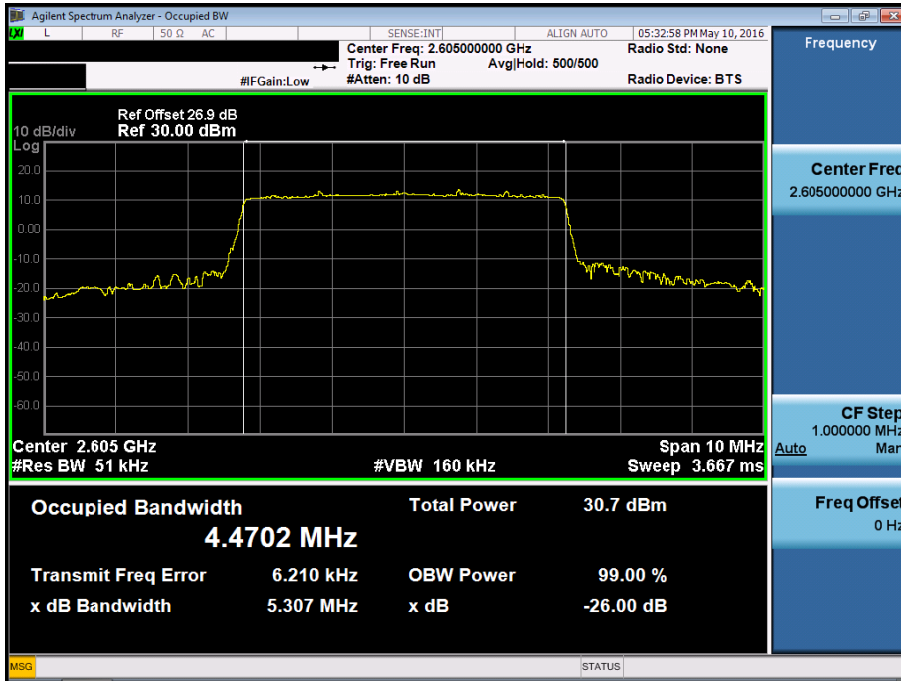

BAND 41. Occupied Bandwidth Plot (5 MHz Ch.40740 16-QAM RB 25)

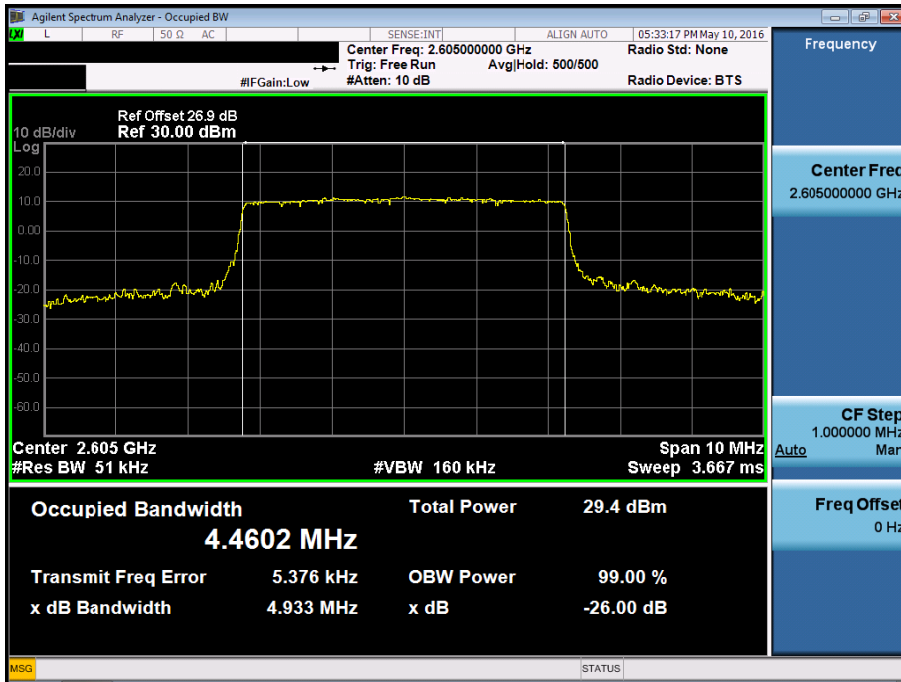

BAND 41. Occupied Bandwidth Plot (10 MHz Ch.40740 QPSK RB 50)

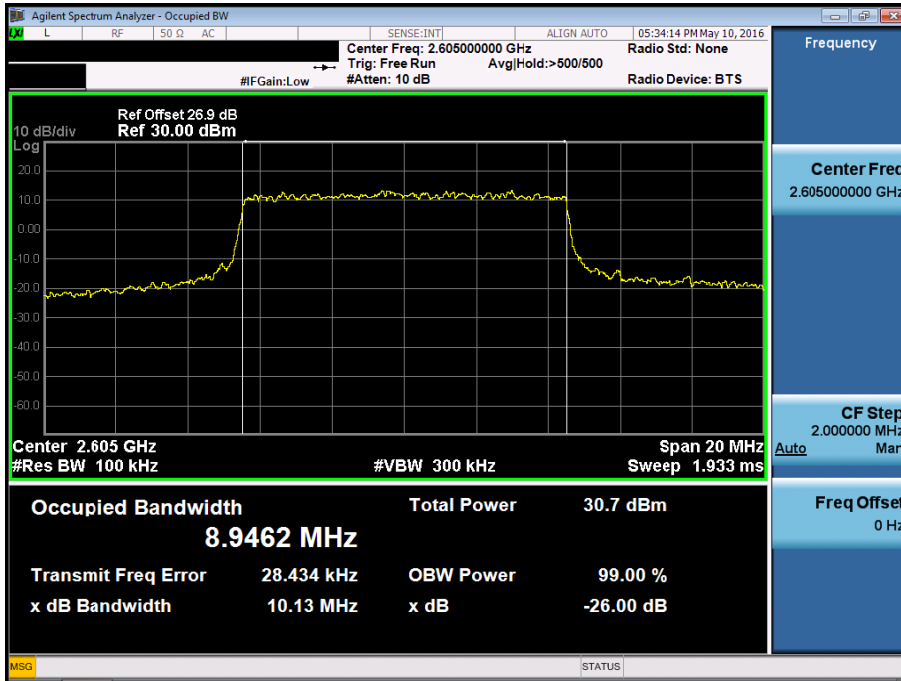

BAND 41. Occupied Bandwidth Plot (10 MHz Ch.40740 16-QAM RB 50)

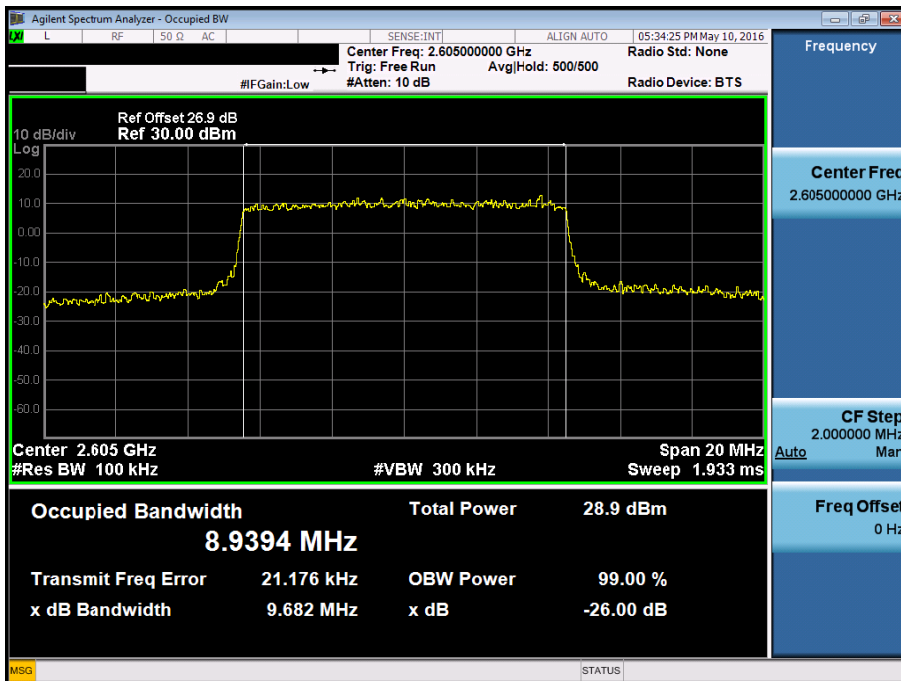

BAND 41. Occupied Bandwidth Plot (15 MHz Ch.40740 QPSK RB 75)

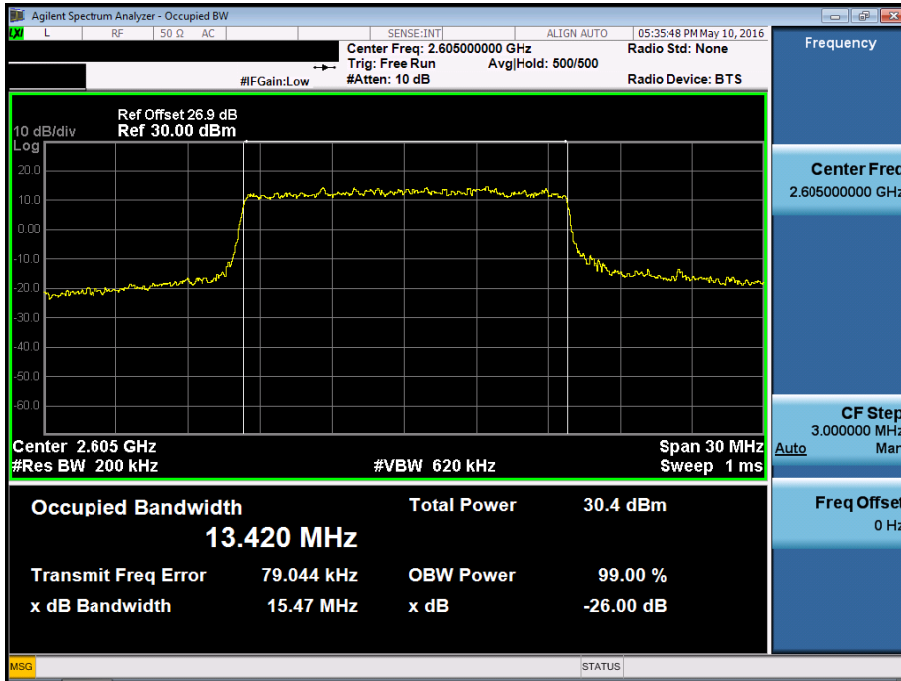

BAND 41. Occupied Bandwidth Plot (15 MHz Ch.40740 16-QAM RB 75)

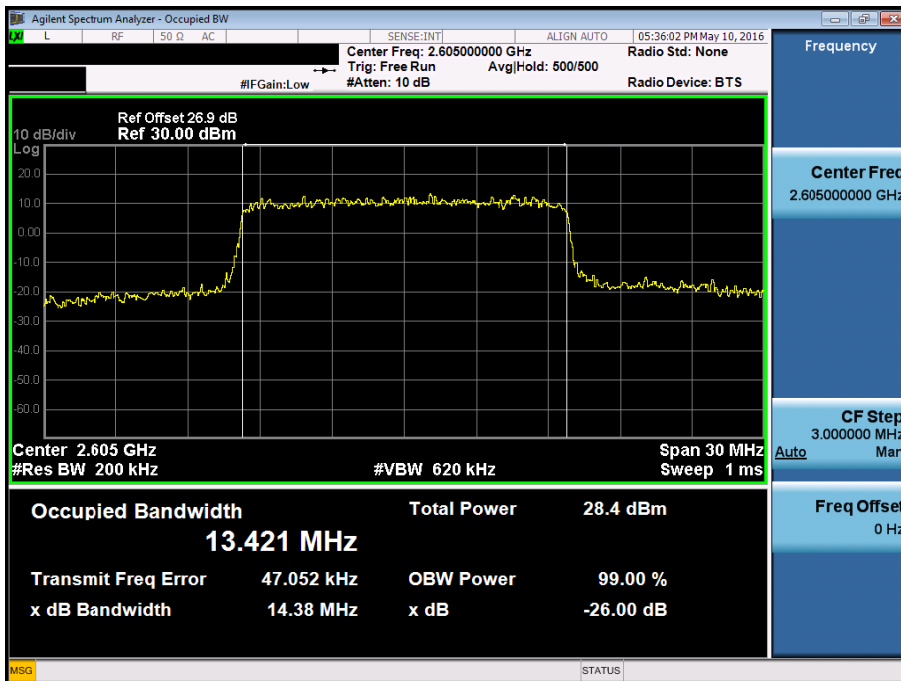

BAND 41. Occupied Bandwidth Plot (20 MHz Ch.40740 QPSK RB 100)

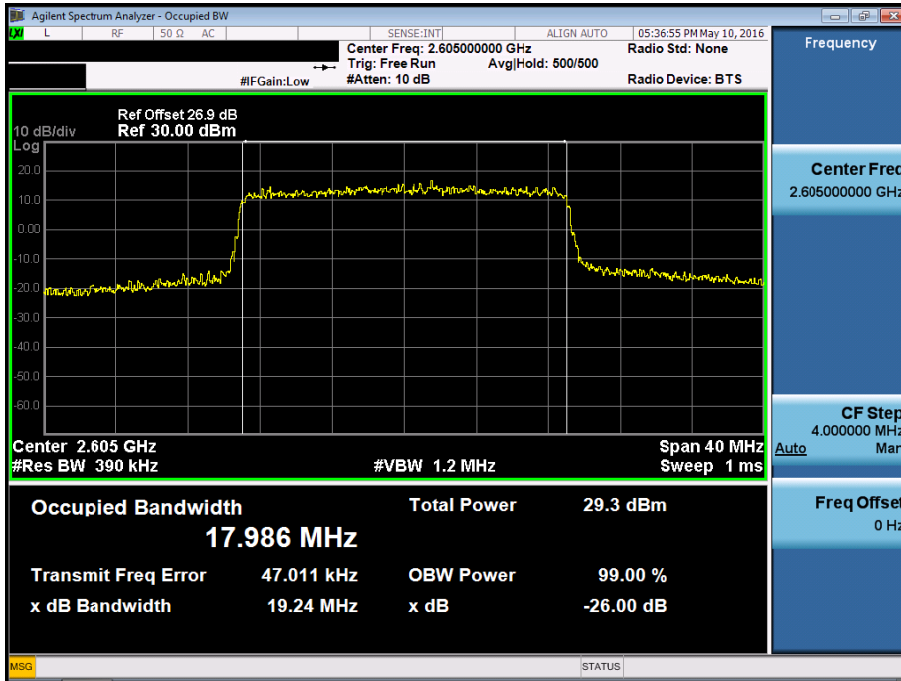

BAND 41. Occupied Bandwidth Plot (20 MHz Ch.40740 16-QAM RB 100)

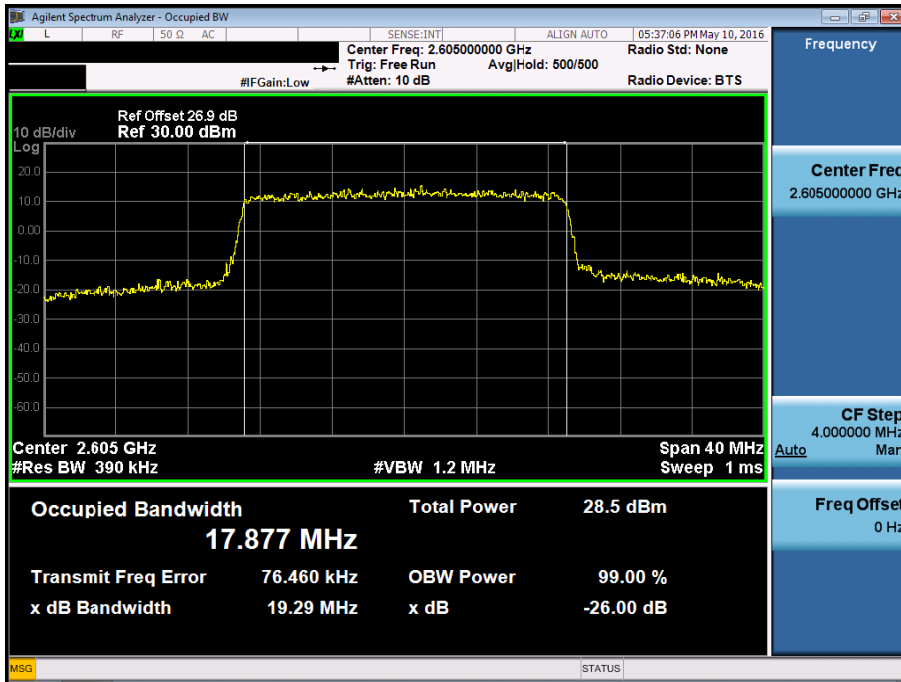

BAND 41. Low Channel Edge Plot (5 MHz Ch.40265 QPSK RB 25)

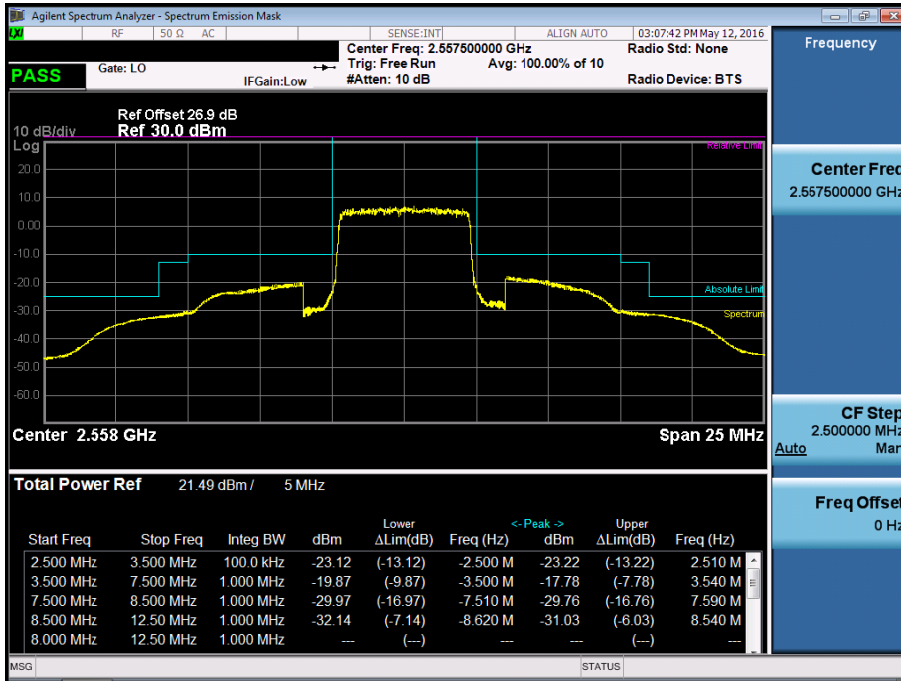

BAND 41. Mid Channel Edge Plot (5 MHz Ch.40740 QPSK RB 25)

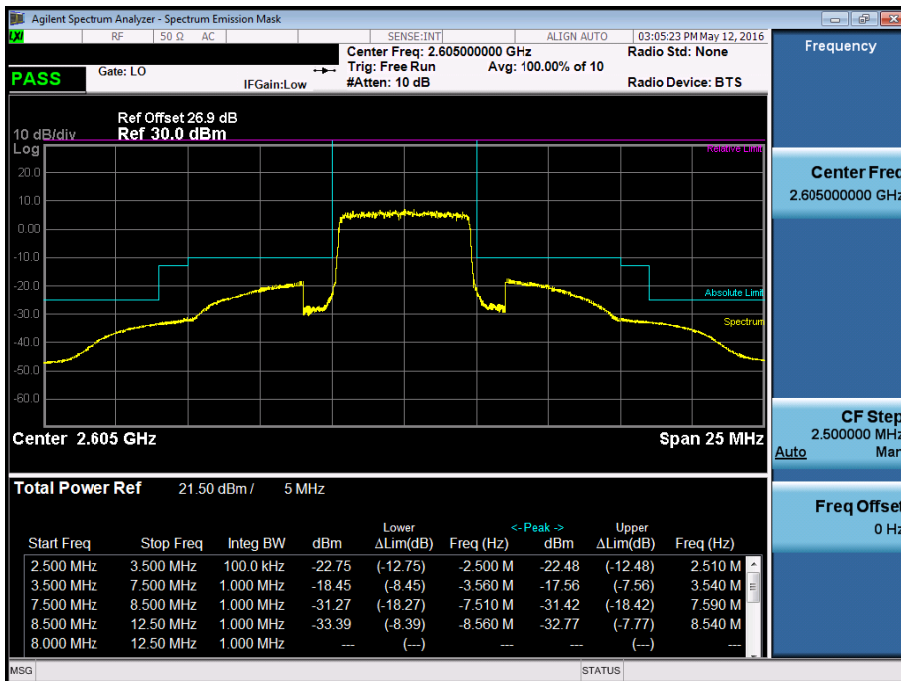

BAND 41. High Channel Edge Plot (5 MHz Ch.41215 QPSK RB 25)

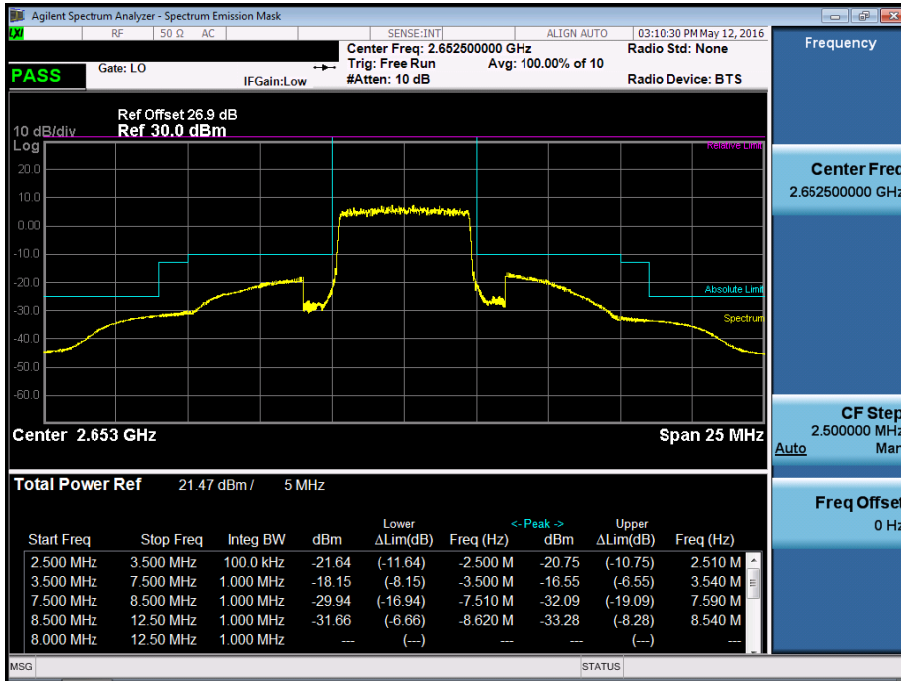

BAND 41. Low Channel Edge Plot (10 MHz Ch.40290 QPSK RB 50)

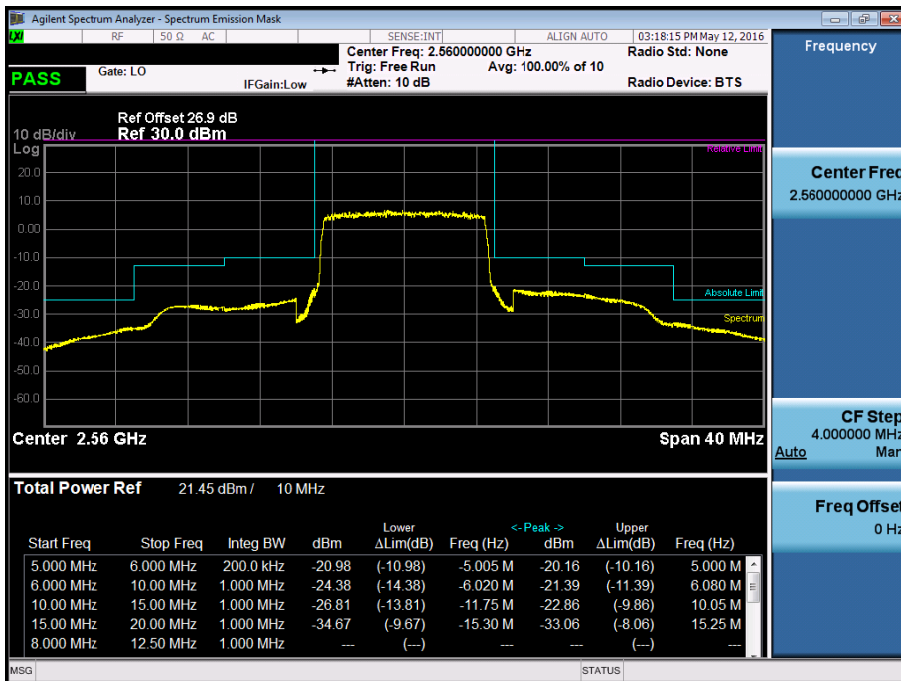

BAND 41. Mid Channel Edge Plot (10 MHz Ch.40740 QPSK RB 50)

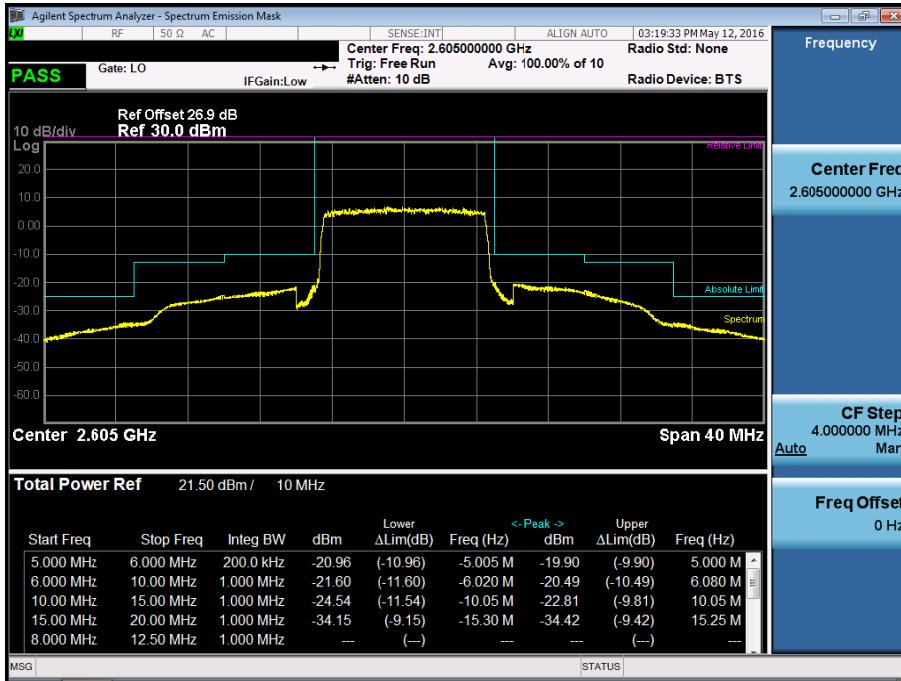

BAND 41. High Channel Edge Plot (10 MHz Ch.41190 QPSK RB 50)

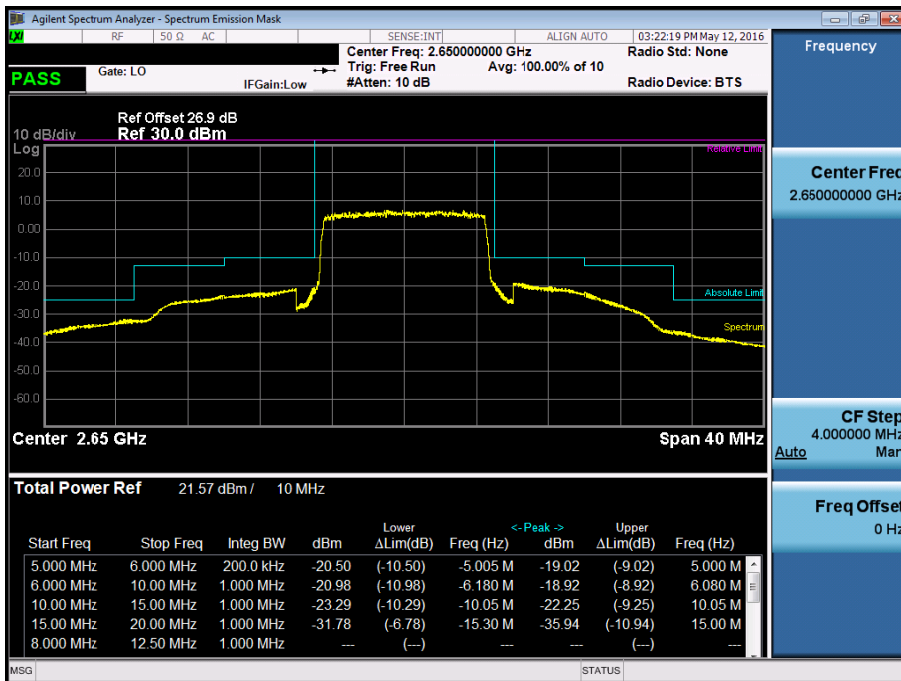

BAND 41. Low Channel Edge Plot (15 MHz Ch.40315 QPSK RB 75)

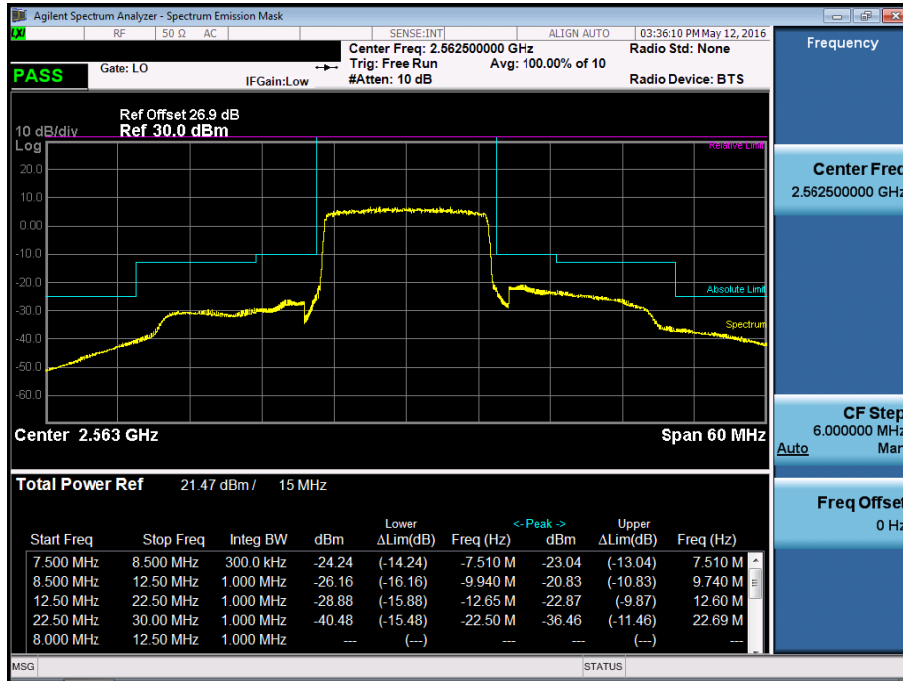

BAND 41. Mid Channel Edge Plot (15 MHz Ch.40740 QPSK RB 75)

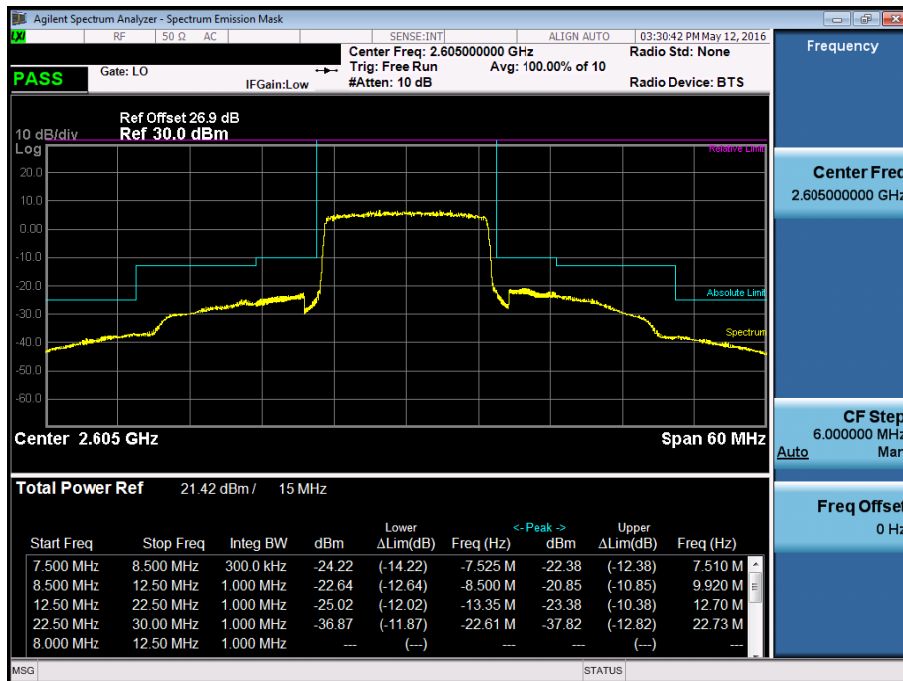

BAND 41. High Channel Edge Plot (15 MHz Ch.41165 QPSK RB 75)

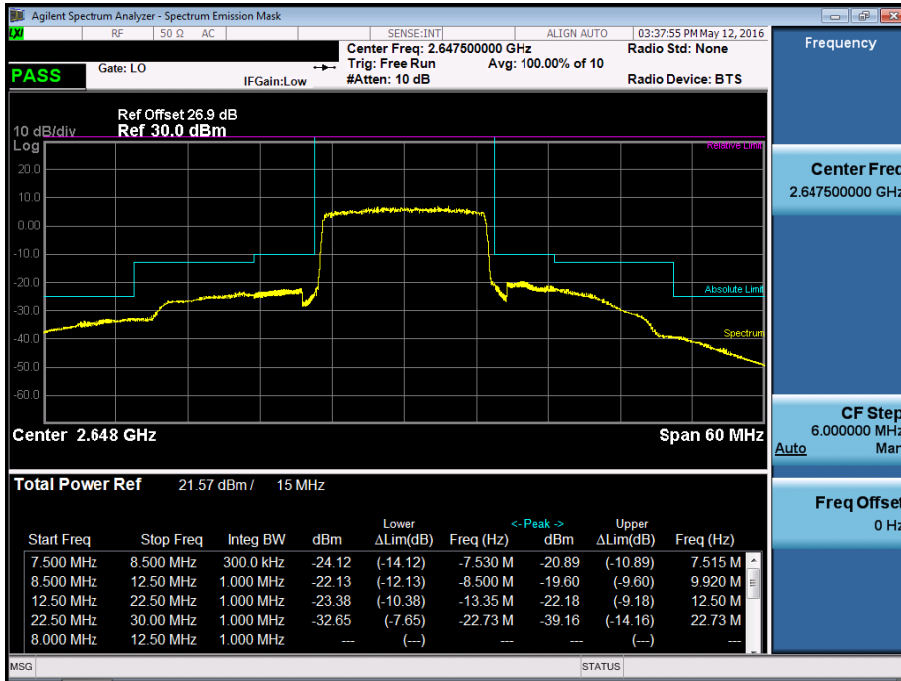

BAND 41. Low Channel Edge Plot (20 MHz Ch.40340 QPSK RB 100)



BAND 41. Mid Channel Edge Plot (20 MHz Ch.40740 QPSK RB 100)

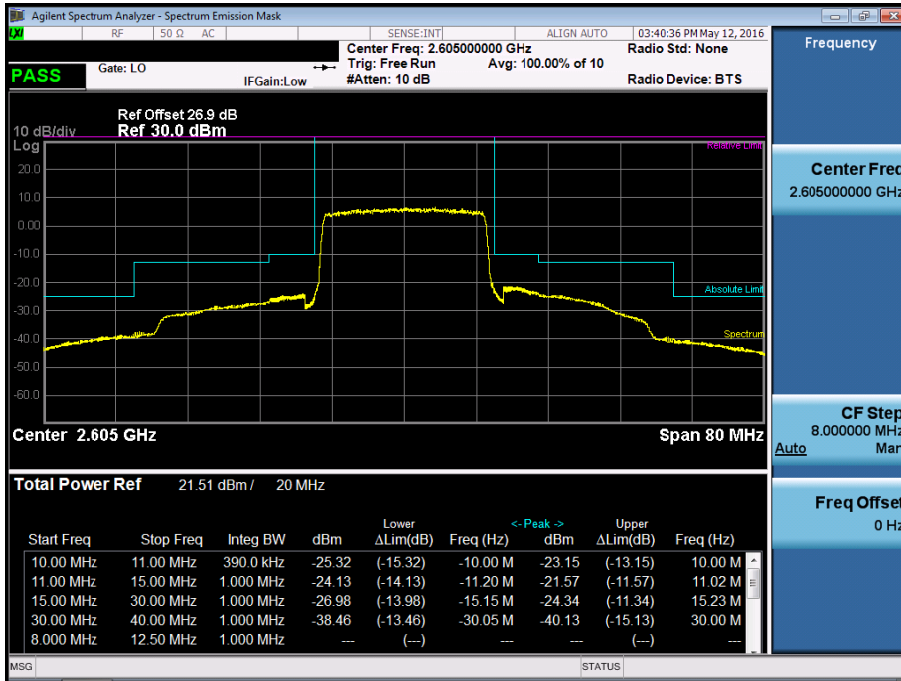

BAND 41. High Channel Edge Plot (20 MHz Ch.41140 QPSK RB 100)

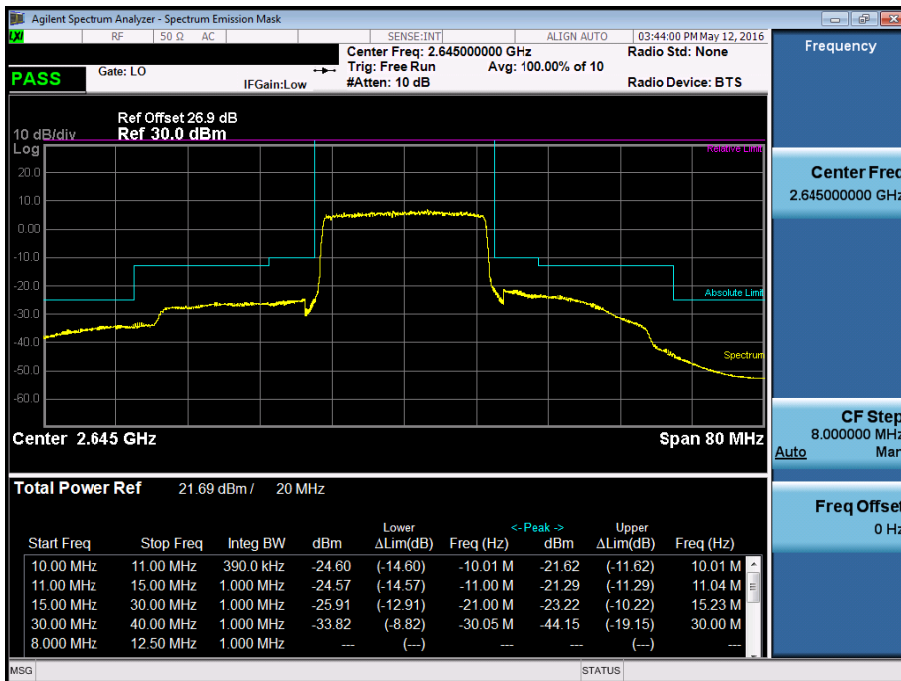

BAND 41. Conducted Spurious Plot 1 (5 MHz Ch.40265 QPSK RB 1, Offset 0)

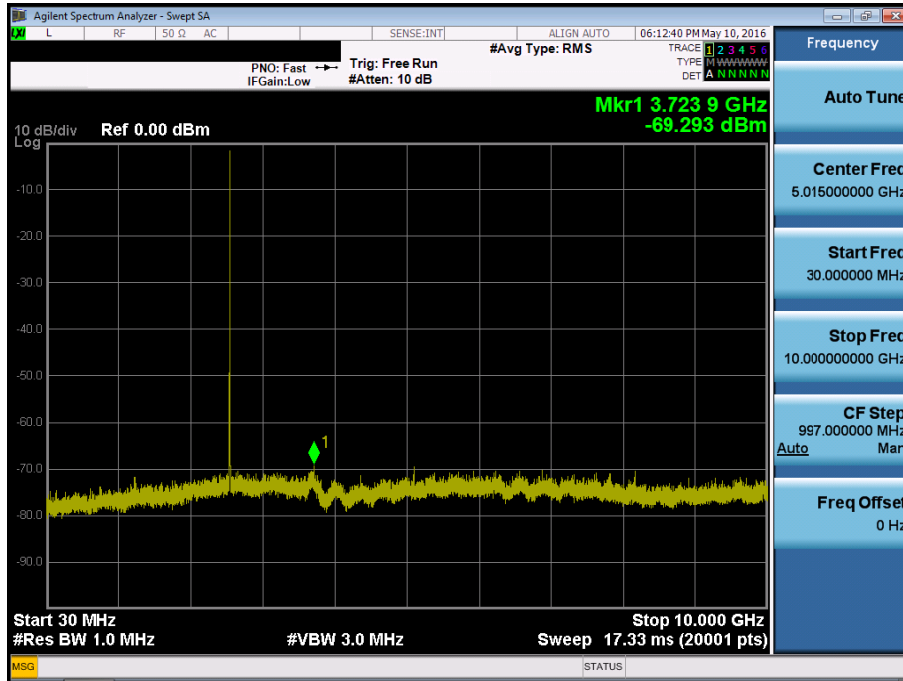

BAND 41. Conducted Spurious Plot 2 (5 MHz Ch. 40265 QPSK RB 1, Offset 0)

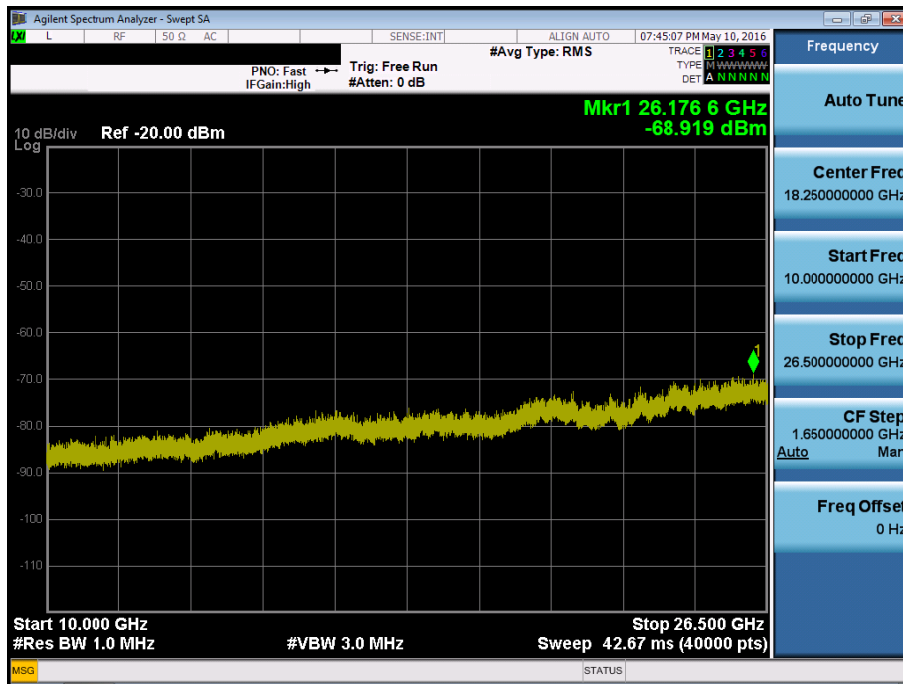

BAND 41. Conducted Spurious Plot 1 (5 MHz Ch.40740 QPSK RB 1, Offset 0)

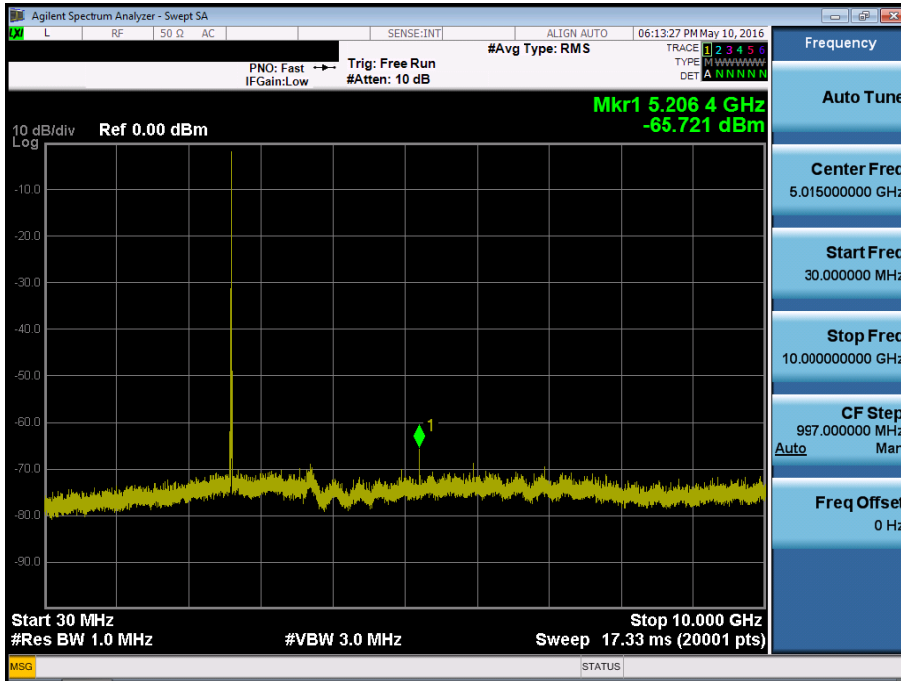

BAND 41. Conducted Spurious Plot 2 (5 MHz Ch. 40740 QPSK RB 1, Offset 0)

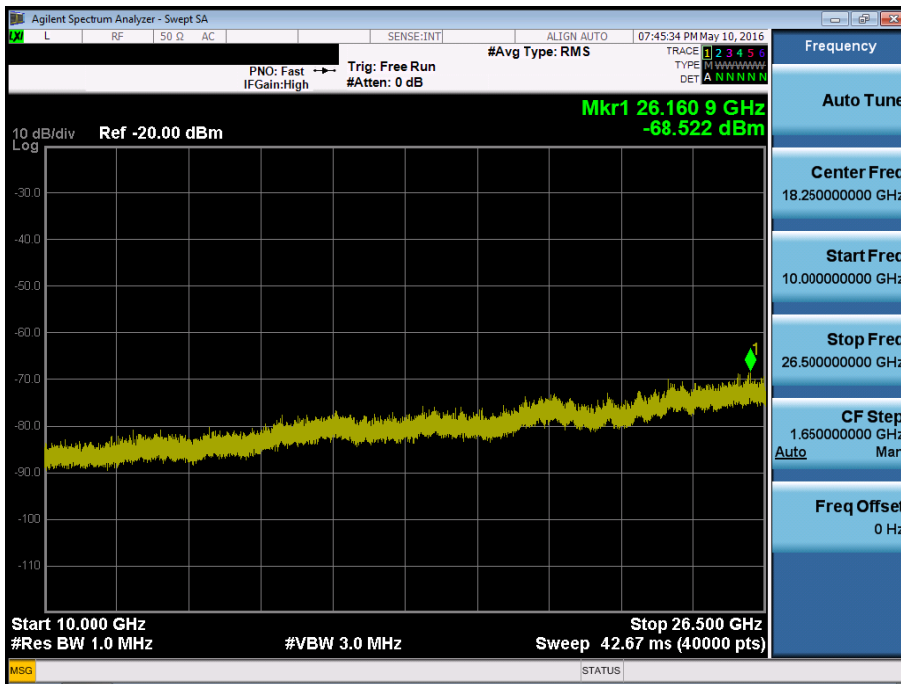

BAND 41. Conducted Spurious Plot 1 (5 MHz Ch.41215 QPSK RB 1, Offset 0)

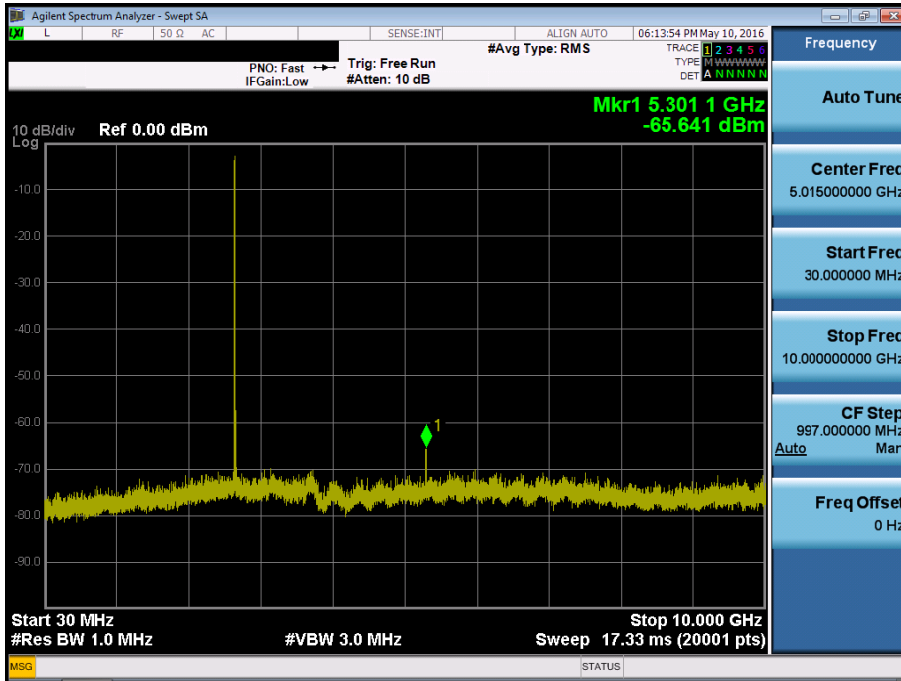

BAND 41. Conducted Spurious Plot 2 (5 MHz Ch. 41215 QPSK RB 1, Offset 0)

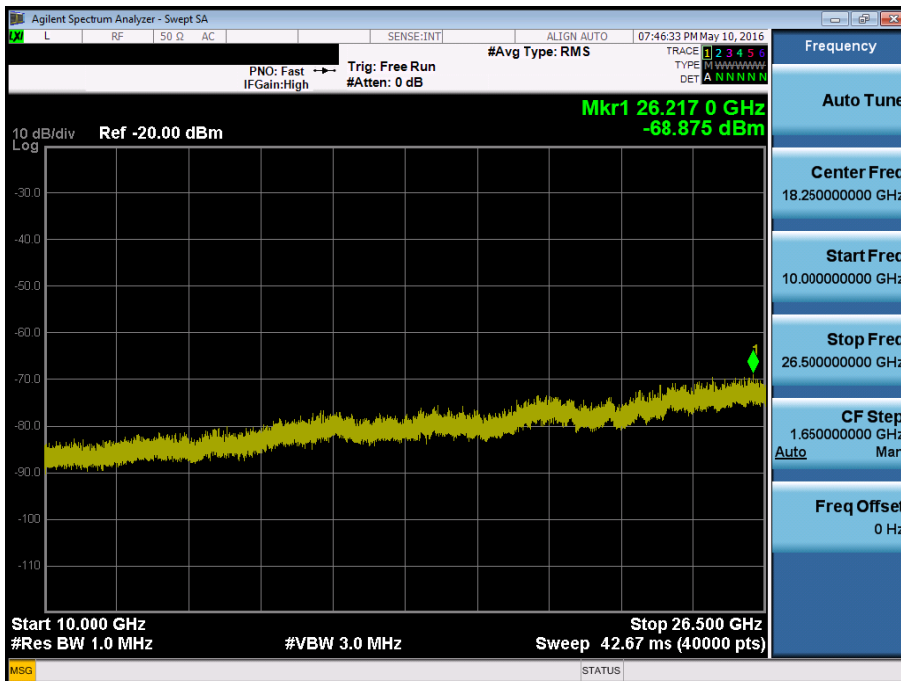

BAND 41. Conducted Spurious Plot 1 (10 MHz Ch.40290 QPSK RB 1, Offset 0)

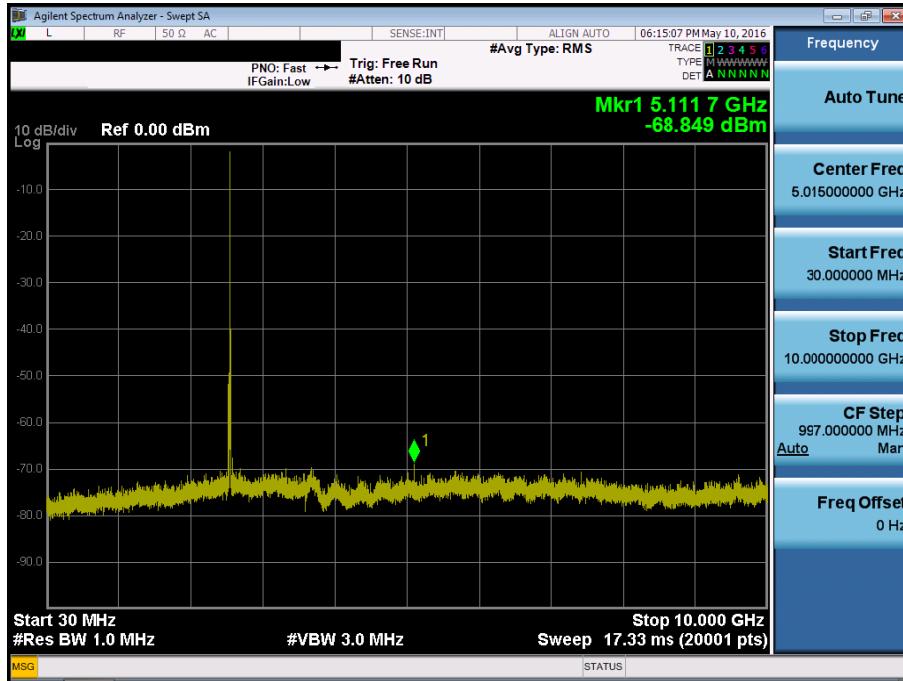

BAND 41. Conducted Spurious Plot 2 (10 MHz Ch. 40290 QPSK RB 1, Offset 0)

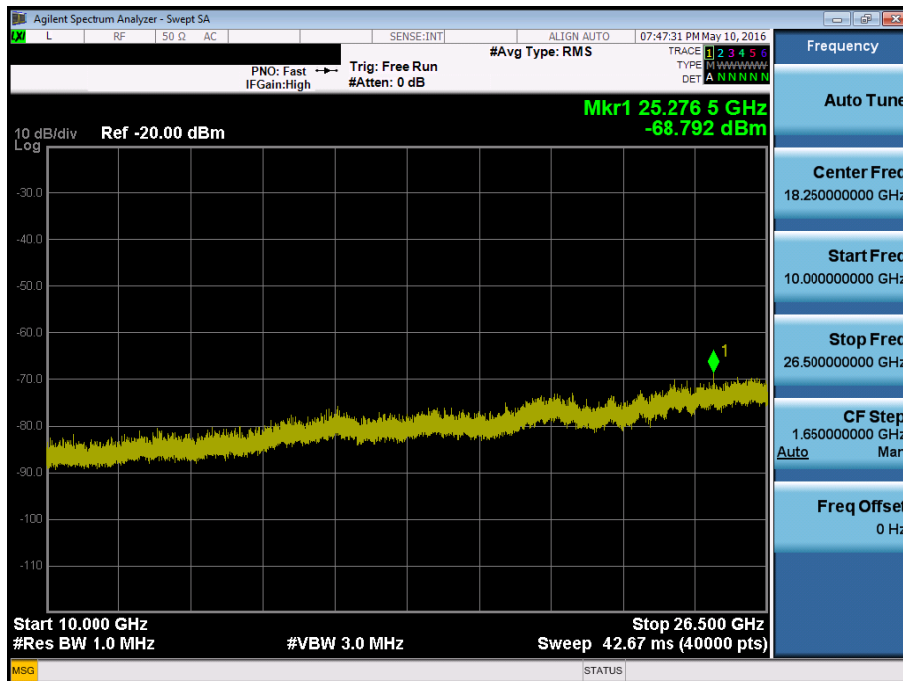

BAND 41. Conducted Spurious Plot 1 (10 MHz Ch.41190 QPSK RB 1, Offset 0)

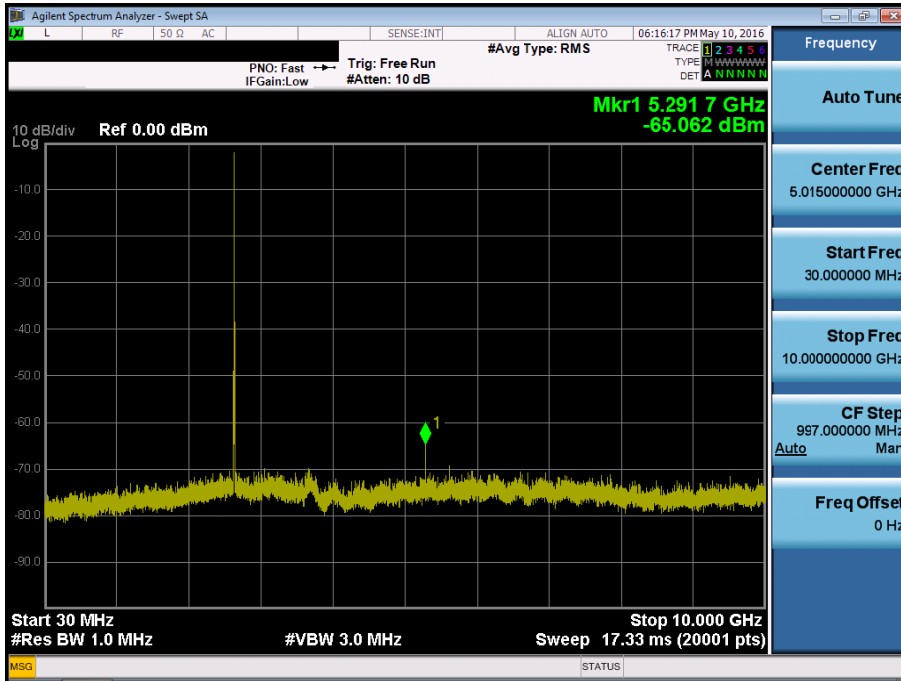

BAND 41. Conducted Spurious Plot 2 (10 MHz Ch. 41190 QPSK RB 1, Offset 0)

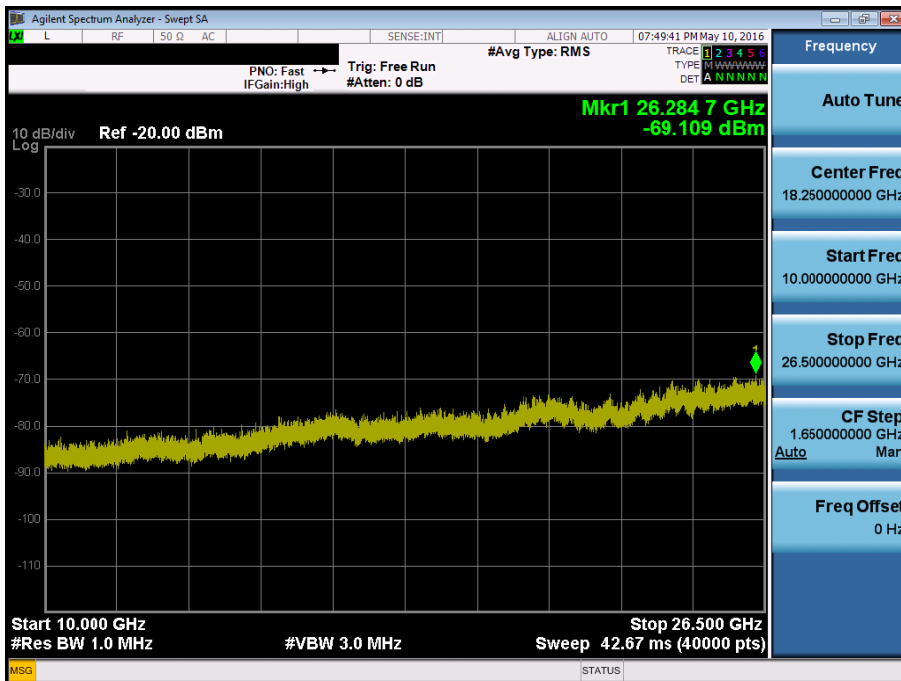

BAND 41. Conducted Spurious Plot 1 (15 MHz Ch.40315 QPSK RB 1, Offset 0)

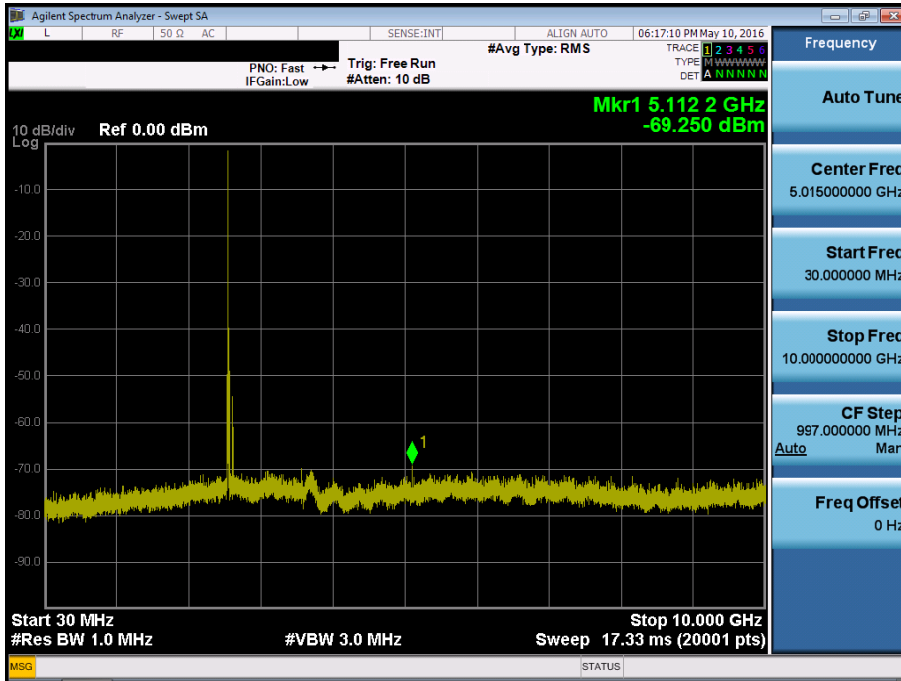

BAND 41. Conducted Spurious Plot 2 (15 MHz Ch. 40315 QPSK RB 1, Offset 0)

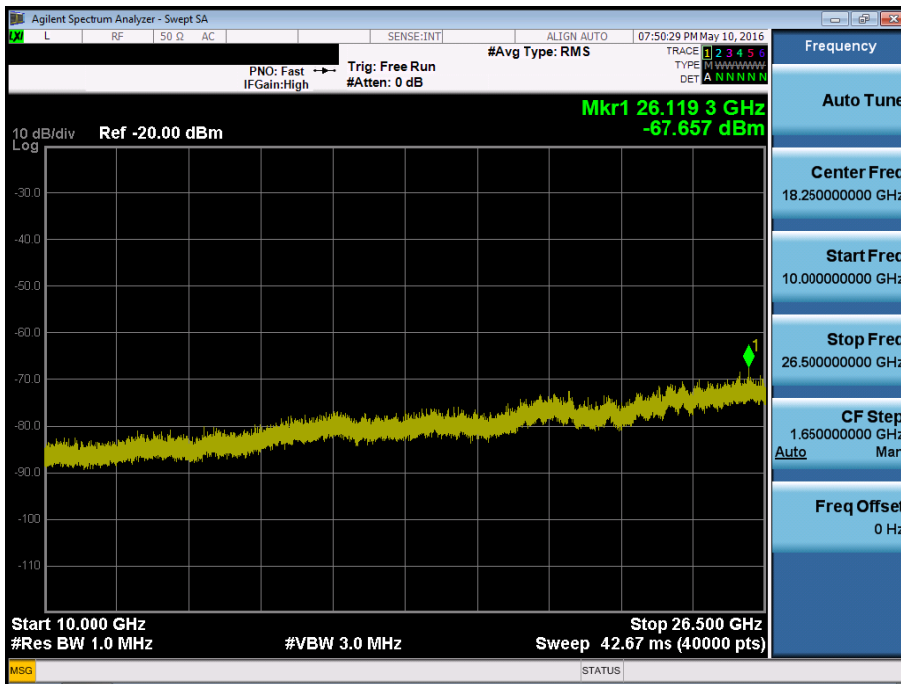

BAND 41. Conducted Spurious Plot 1 (15 MHz Ch.41165 QPSK RB 1, Offset 0)

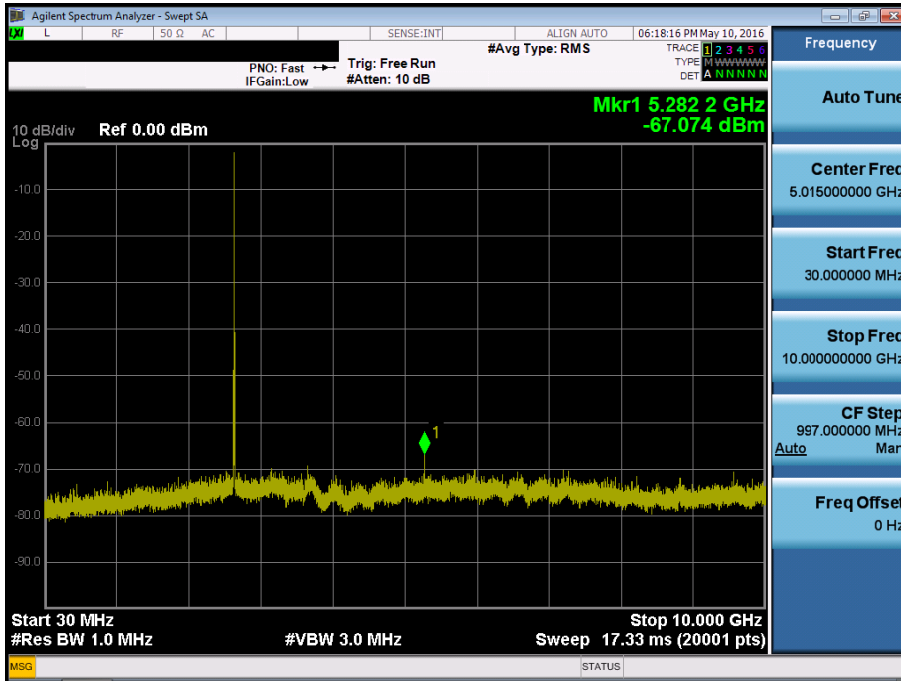

BAND 41. Conducted Spurious Plot 2 (15 MHz Ch. 41165 QPSK RB 1, Offset 0)

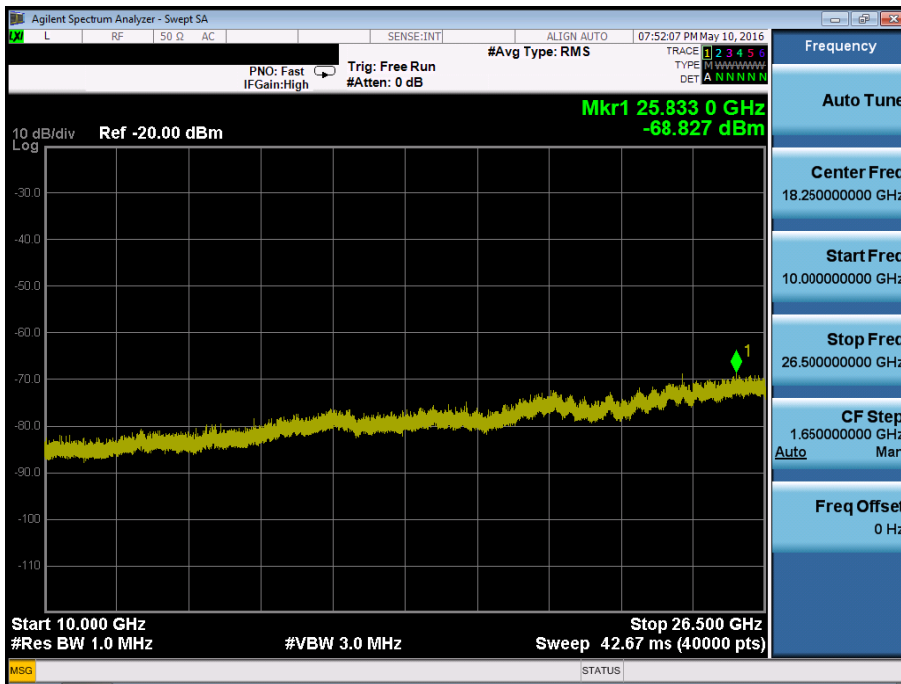

BAND 41. Conducted Spurious Plot 1 (20 MHz Ch.40340 QPSK RB 1, Offset 0)

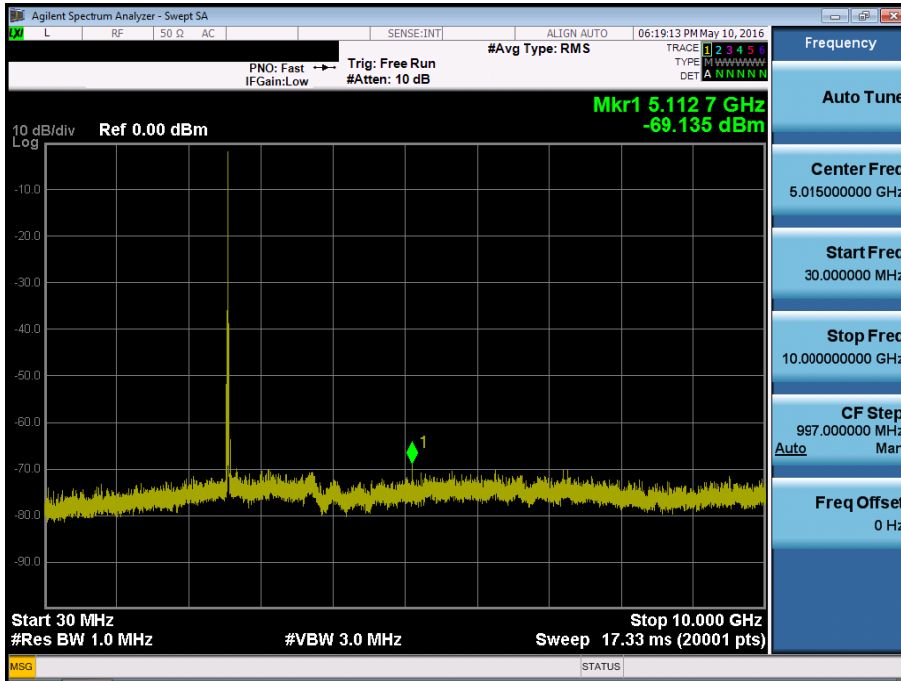

BAND 41. Conducted Spurious Plot 2 (20 MHz Ch. 40340 QPSK RB 1, Offset 0)

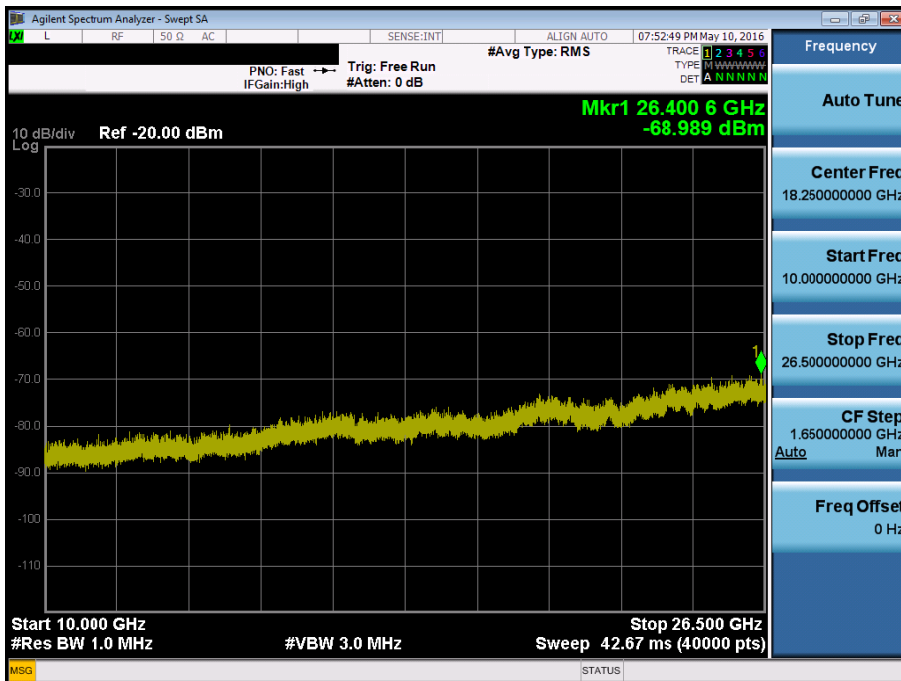

BAND 41. Conducted Spurious Plot 1 (20 MHz Ch.40740 QPSK RB 1, Offset 0)

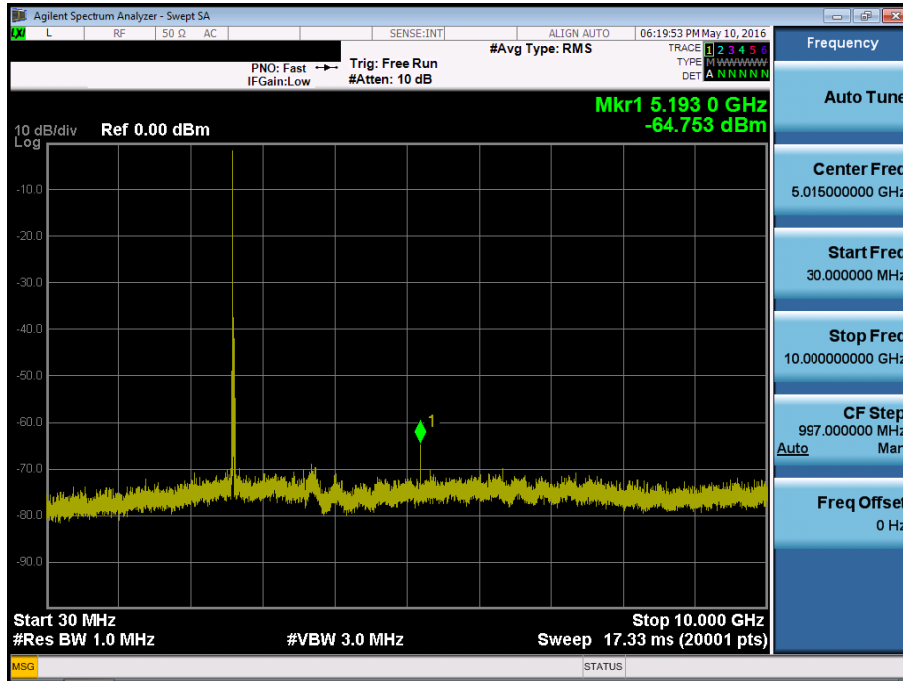

BAND 41. Conducted Spurious Plot 2 (20 MHz Ch. 40740 QPSK RB 1, Offset 0)

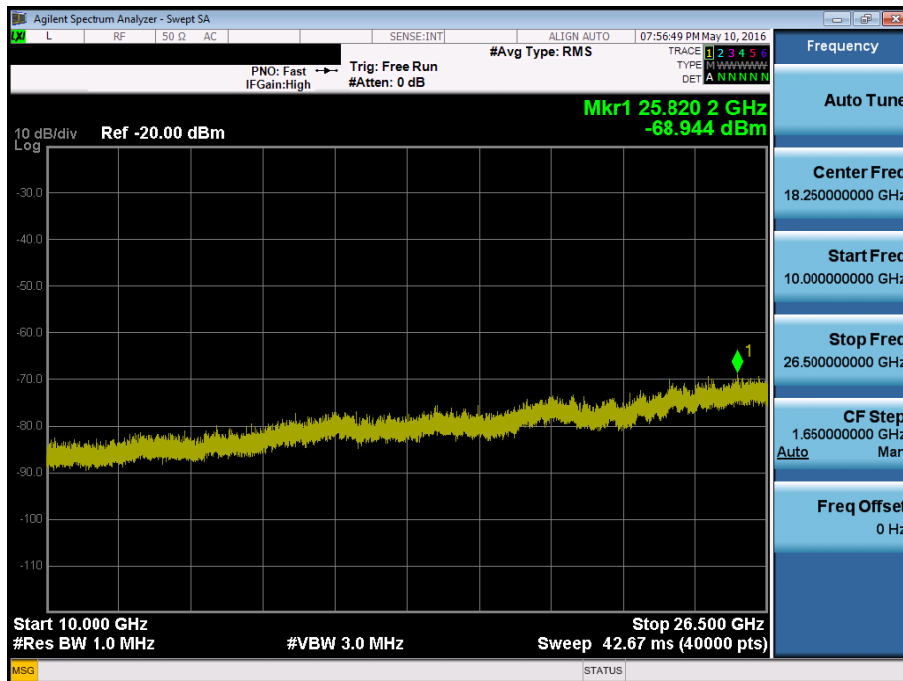

BAND 41. Conducted Spurious Plot 1 (20 MHz Ch.41140 QPSK RB 1, Offset 0)

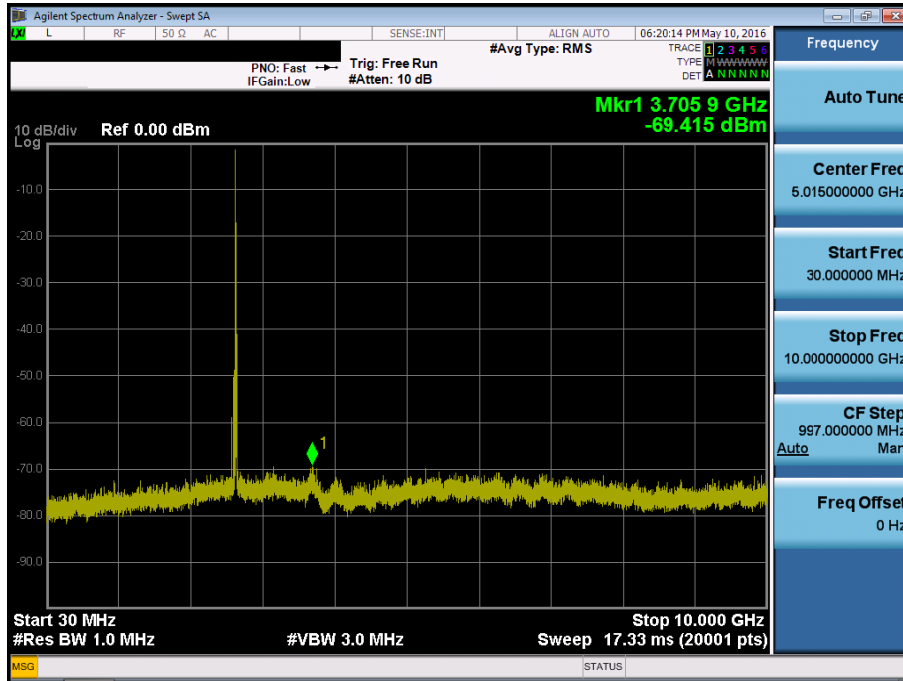

BAND 41. Conducted Spurious Plot 2 (20 MHz Ch. 41140 QPSK RB 1, Offset 0)

