

EMC TEST REPORT

CS Management Center, Samsung Electronics Co., Ltd.
416 Maetan 3-Dong, Yeongtong-Gu, Suwon-Si, Gyeonggi-Do, 443-742 Korea
(Tel: 82 31 277 7752, Fax: 82 31 277 7753)
FCC Registration No. : KR0004
NVLAP Code : 200623-0



1. Applicant

- Name of organization : **Samsung Electronics Co., Ltd.**
- Address : 416 Maetan 3-Dong, Yeongtong-Gu, Suwon-Si, Gyeonggi-Do
443-742 Korea
- Date of application : 2006.02.01

2. Purpose for the report : Approval for EMC

3. Kind of product : USB Flash Drive (Model name : MCAQD04GA**P-*4***)

4. Date of test : 2006. 02. 03

5. Applied standard : FCC Part 15 B, Class B

6. FCC ID or DoC/Verification : A3LSECCTOC

7. Report No. : LBE060348 Issue 1

8. Test result : **PASS**

The equipment under test has found to be compliant with the applied standards.
(Refer to the attached test result for more detail.)

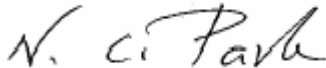
Tested by Name : Hyeok Je Kwon 	Reviewed by Name : No Cheon Park 
--	---

This report is the test result about the sphere accredited by KOLAS which signed the Mutual Recognition Arrangement of International Laboratory Accreditation Cooperation.

2006. 02. 14

Samsung Electronics Co., Ltd.
Chief of CS Management Center

TEST RESULT

Test Report No. : LBE060348

Applicant / Address : Samsung Electronics Co., Ltd.
416 Maetan 3-Dong, Yeongtong-Gu, Suwon-Si, Gyeonggi-Do
443-742 Korea

Manufacture / Address : Samsung Electronics Co., Ltd.
San#16 Banwol-Ri, Taeon-up, Hwasung-City, Gyeonggi-Do,
445-701, Korea

EUT : 1. Product name : USB Flash Drive
2. Model name : MCAQD04GA**P-*4***
3. Brand name : Samsung
4. Variant model : MC8DD02GA**P-*4***, MC4GD01GA**P-*4***
MC2GD512A**P-*4***, MC1GD256A**P-*4***
MC1GD128A**P-*4***, MC8QD02GA**P-*4***
MC4DD01GA**P-*4***

Basic Standards : ANSI C63.4:2003

Test Result : **PASS**
The equipment under test has found to be compliant
with the applied standards

Test Lab. : CS Management Center, Samsung Electronics Co., Ltd.



Tested by : Hyeok Je, Kwon

Reviewed by : No Cheon Park

Date of Issue : 2006. 02. 14



Test Report No. : LBE060348

Table of contents

1. General information

- 1.1 Basic information related product
- 1.2 Detail information related product
- 1.3 Operating mode and condition
- 1.4 Equipment modifications
- 1.5 Test procedure
- 1.6 Test configuration
- 1.7 Applied standard
- 1.8 Test facility

2. Summary of test results

3. Description of individual tests

- 3.1 Conducted Emission
- 3.2 Radiated Emission

4. Appendix

- 4.1 Test photography
- 4.2 EUT photography

1. General information

1.1 Basic information related product

Applicant	Samsung Electronics Co., Ltd.
Model name	MCAQD04GA**P-*4***
Applicant address	416 Maetan 3-Dong, Yeongtong-Gu, Suwon-Si, Gyeonggi-Do 443-742 Korea
Contact person	Hee Tai, Kim
Kind of product	USB Flash Drive
Variant model	MC8DD02GA**P-*4*** → 2GB MC4GD01GA**P-*4*** → 1GB MC2GD512A**P-*4*** → 512MB MC1GD256A**P-*4*** → 256MB MC1GD128A**P-*4*** → 128MB MC8QD02GA**P-*4*** → 2GB MC4DD01GA**P-*4*** → 1GB
Manufacturer	Samsung Electronics Co., Ltd. San#16 Banwol-Ri, Taeon-up, Hwasung-City, Gyeonggi-Do, 445-701, Korea
New / Alternative / Permissive change information	New

1.2 Detail Information related product

1.2.1 Specification

Item	Specification	Remark
USB Flash Drive	<ul style="list-style-type: none"> • Fully compatible with the USB 2.0 High speed Specification, USB-IF certified • USB Specification V1.1 Mass Storage Compliance • USB Bulk Only Mass Storage Support • USB Class Definition for Bootability Support • Interface Speed: up to <ul style="list-style-type: none"> - High Speed: 25~400M Mb/s - Full Speed: 500Kb/s~10Mb/s • High Performance <ul style="list-style-type: none"> - Sequential Read: 20MB/s - Sequential Write: 10MB/s • Storage Capacities: 128MB~4GB • Low Vcc Program Inhibit Function • Auto Sleep Mode • USB Bus Powered (4.75 Volt ~5.25 Volt) • Suspend: ≤ 500uA 	-

1.3 Operating mode and condition

MP3 files in the EUT are played by windows media player connected to the laptop.

The program was playing the mp3 files continuously during the each test.

- Test Voltage : AC 120 V, 60 Hz

1.4 Equipment modifications

No equipment modifications were required.

1.5 Test procedure

1.5.1 Conducted emission

EUT was placed on a platform nominal size, 1 m by 1.5 m, raised 80 cm above the conducting ground plane. The rear of tabletop was located 40 cm to the vertical conducting ground plane.

The rear of EUT, including peripherals was aligned and flush with rear of tabletop.

All other surfaces of tabletop was at least 80 cm from any other grounded conducting surface.

I/O cables and AC cables that were connected to the peripherals were bundled in center.

They were folded back and forth forming a bindle 30 cm to 40 cm long and were handed at a 40 cm height to the ground plane.

Each EUT current-carrying power lead, except the ground(safety) lead, were individually connected through a LISN to the input power source.

All unused 50 ohm connectors of the LISN were resistively terminated in 50 ohm when not connected to the measuring instrument.

Frequency Band [MHz]	Instrument	Detector	Resolution Bandwidth	Video Bandwidth
0.15 to 30	EMI Receiver	Quasi-Peak	9 kHz	-
		Average	9 kHz	-

1.5.2 Radiated emission

EUT was placed on a platform of nominal size, 1 m by 1.5 m, raised 80 cm above the conducting ground plane. The rear of EUT, including peripherals was aligned and flush with rear of tabletop.

The I/O cables that were connected to the peripherals were bundle in center.

They were folded back and forth forming a bundle 30 cm to 40 cm long and were hanged 40 cm height to the ground plane.

Test was made with the antenna positioned in both the horizontal and vertical planes of polarization.

The measurement antenna was varied in height above the conducting ground plane and the turn table azimuth was varied to obtain the maximum signal strength

The system configuration, clock speed, mode of operation or video resolution, turntable azimuth with respect to the antenna were noted for each frequency found.

The spectrum was scanned from 30 to 1 000 MHz using biconiLog antenna.

Frequency Band [MHz]	Instrument	Detector	Resolution Bandwidth	Video Bandwidth
30 to 1 000	EMI Receiver	Quasi-Peak	120 kHz	-

1.6 Test configuration

1.6.1 Used EUT and peripherals

Seq	Device	Model Name	Serial #	Maker	Note
A	USB Flash Drive	MCAQD04GA**P- *4***	-	Samsung	EUT
B	Notebook PC	PP05S	-	Samsung	DoC
C	AC Adaptor	ADP-50HH REV.B	CNM0W6052M48661- 4AK-00AM	Dell	
D	EXT.USB CD-ROM DRIVE	PD01S	0P1516-42940-340- 001K	Dell	DoC
E	MP3 Player	M854	U22370Z2MJ2	Inventec Appliances Corp.	DoC
F	Heatset	Axis-202	-	Labtec	DoC

1.6.2 Used cable description

Mark	Connect Cable	Length [m]	Shielded [Y/N]	Remark
1	AC Power Cable	1.8	No	-
2	USB Cable	0.5	Yes	-
3	1394 Cable	1.0	Yes	
4	AVV Cable	2.0	Yes	-

1.6.3 Block Diagram

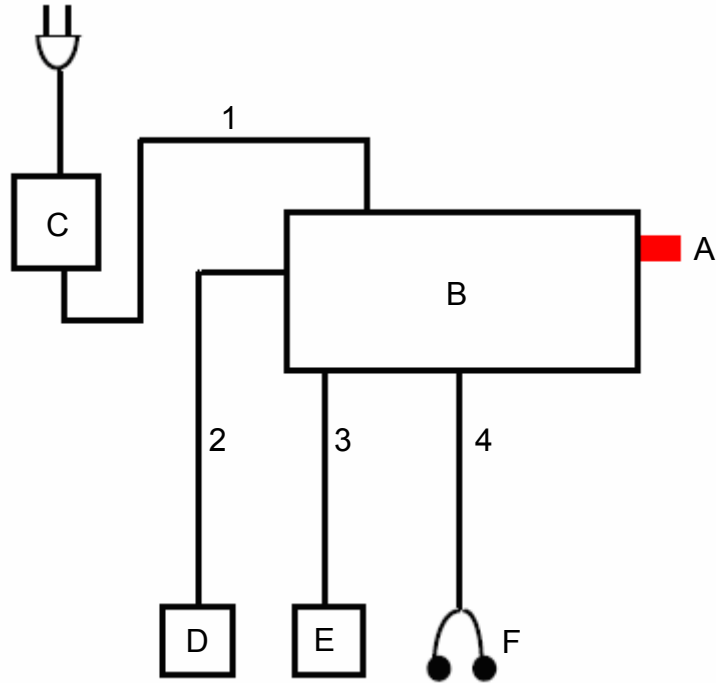

1.7 Applied Standards

Test standard	Basic standard
FCC Part 15 B	ANSI C63.4:2003

1.8 Test Facility

1.8.1 General information

The sites are constructed in conformance with the requirements of ANSI C63.4 and CISPR 22, 16-1, 16-2.

This EMC Testing Lab. is accredited by Korea Laboratory Accreditation Scheme(KOLAS) which signed the International Laboratory Accreditation Cooperation (ILAC) Mutual Recognition Arrangement (MRA) for the above test item(s) and test method(s).

This Lab. is operated as testing laboratory in accordance with the requirements of ISO/IEC 17025:1998.

1.8.2 Accreditation and listing



1.8.3 Measurement uncertainty

(According to CISPR 16-4 and Lab. 34)

Test item	Measurement uncertainty
Conducted emission	± 3.3 dB
Radiated emission (Bi-Log Antenna)	± 4.3 dB



Test Report No. : LBE060348

2. Summary of test results

Result : PASS

The equipment under test (EUT) has been found to comply with the applied standards.

Section of the Product Standard	Applied Standard	Result	
Electromagnetic Emission Test			
3.1	Conducted Emission	FCC Part 15 B	Complied
3.2	Radiated Emission	FCC Part 15 B	Complied

3. Description of individual tests

3.1 Conducted emission

3.1.1 Test information

Test engineer	Hyeok Je, Kwon
Test date	Feb 3, 2006
Climate condition	Ambient temperature : 25.0 °C, Relative humidity : 34 % Atmospheric pressure : 103.1 kPa
Test place	Shielded room #1

3.1.2 Test equipment

Equipment	Model name	Manufacturer	Serial no.	Calibration	
				Next date	Interval
Field strength meter	ESCI	R&S	100136	2006-04-17	12
LISN	ENV216	R&S	100116	2006-09-08	12
LISN	ENV216	R&S	100107	2006-08-18	12
Test Software	EMC 32	R&S	Ver 4.40.0	N/A	N/A

3.1.3 Test result : **Pass**

The Measured emissions of the EUT have found to be below the specified limits.

3.1.4 Test data and graph

The Initial step in collecting conducted data was to perform a peak and average scan over the measurement range using a receiver. The find data represents worst-case emissions.

Hardware Setup: Voltage with 2-Line-LISN - [EMI conducted]

Subrange 1

Frequency Range: 150kHz - 30MHz
Receiver: ESCI 3
Transducer: ENV216 / Receiver-2-Line-LISN ENV216

Scan Setup: EN55022_B_2-Line-LISN 1s [EMI conducted]

Hardware Setup: Voltage with 2-Line-LISN
Level Unit: dB μ V

Subrange	Detectors	IF Bandwidth	Meas. Time	Receiver
150kHz - 30MHz	QuasiPeak; Average	9kHz	1s	ESCI 3

EN55022_B with 2-Line-LISN

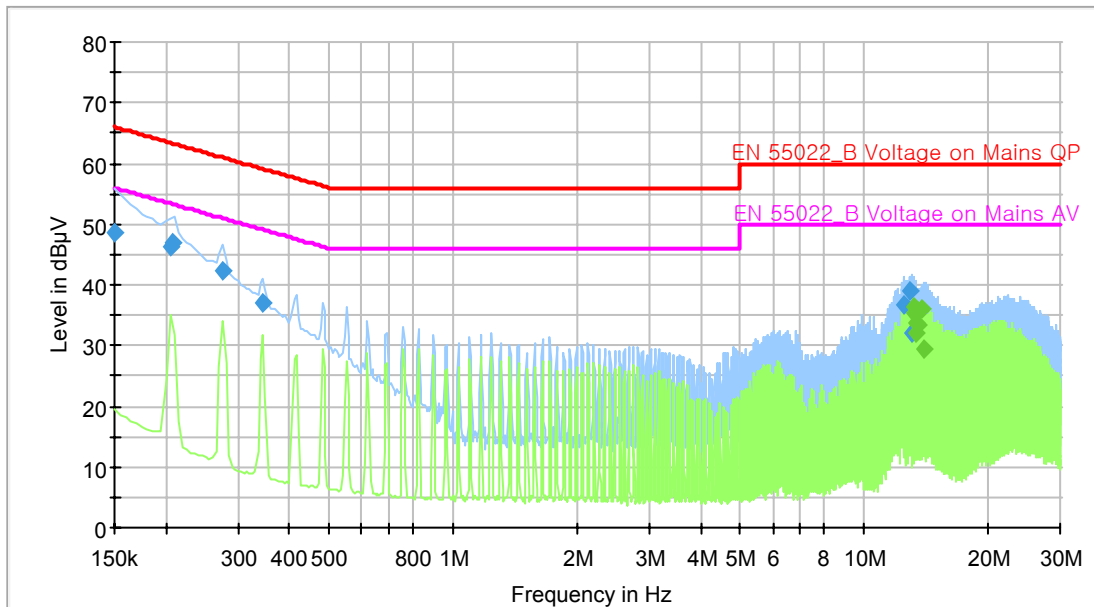

Final Measurement Detector 1

Frequency (MHz)	QuasiPeak (dB μ V)	Line	Corr. (dB)	Margin (dB)	Limit (dB μ V)
0.150000	48.5	N	9.6	17.5	66.0
0.206500	46.1	N	9.6	17.2	63.3
0.207500	46.9	L1	9.6	16.4	63.3
0.275500	42.3	L1	9.6	18.7	61.0
0.345500	37.1	L1	9.6	21.9	59.1
12.515500	36.6	L1	9.7	23.4	60.0
12.865500	39.1	N	9.7	20.9	60.0
13.130500	31.9	N	9.7	28.1	60.0

Final Measurement Detector 2

Frequency (MHz)	Average (dB μ V)	Line	Corr. (dB)	Margin (dB)	Limit (dB μ V)
13.209500	35.5	N	9.7	14.5	50.0
13.279500	36.2	N	9.7	13.8	50.0
13.345500	32.0	N	9.7	18.0	50.0
13.414500	33.6	L1	9.7	16.4	50.0
13.484500	33.5	N	9.8	16.5	50.0
13.554500	35.6	N	9.8	14.4	50.0
13.899500	36.0	N	9.8	14.0	50.0
13.964500	29.3	N	9.8	20.7	50.0

* QP : Quasi-peak, AV: Average

* Level (QuasiPeak or Average) = Meter Reading(QP or AV) + Corr. (LISN Insertion loss + Cable loss)

* Margin = Limit – Result

3.2 Radiated Emission

3.2.1 Test information

Test engineer	Hyeok Je, Kwon
Test date	Feb 3, 2006
Climate condition	Ambient temperature : 22 °C, Relative humidity : 35 % Atmospheric pressure : 101.8 kPa
Test place	10m Semi Anechoic Chamber #1

3.2.2 Test equipment

Equipment	Model Name	Manufacturer	Serial No.	Calibration	
				Next Date	Interval
EMI Test Receiver	ESI-26	R&S	100289	2006-04-11	12
EMI Test Receiver	ESI-26	R&S	100291	2006-04-12	12
Ant. Mast	MA4000	inn-co	-	N/A	N/A
Ant. Mast	MA4000	inn-co	-	N/A	N/A
Mast Controller	CO2000	inn-co	-	N/A	N/A
Amplifier	310N	SONOMA	251674	2006-03-08	12
Amplifier	310N	SONOMA	251677	2006-03-08	12
Amplifier	NS4900	TOYO	-	N/A	N/A
Bi-log Antenna	CBL6141A	SCHAFFNER	4266	2006-05-24	12
Bi-log Antenna	CBL6141A	SCHAFFNER	4268	2006-05-24	12

3.2.3 Test result : **Pass**

The Measured emissions of the EUT have found to be below the specified limits.

3.2.4 Test data

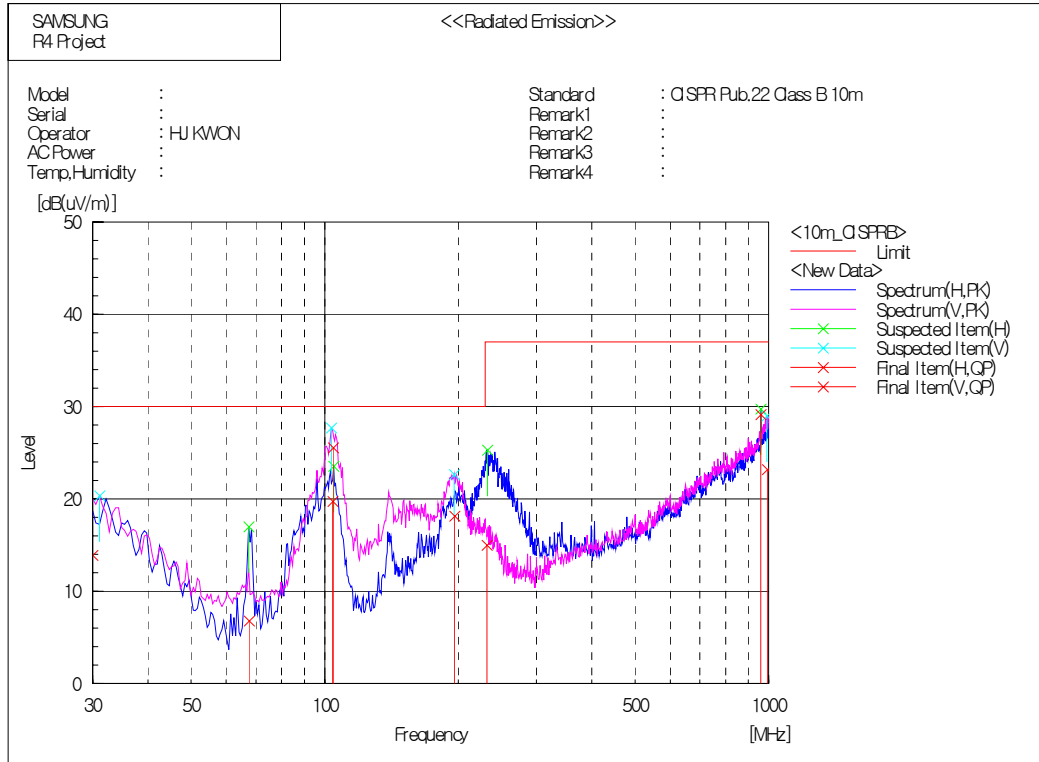

Final Result

--- Horizontal Polarization (QP)---

No.	Frequency [MHz]	Reading [dB(uV)]	c.f [dB(1/m)]	Result [dB(uV/m)]	Limit [dB(uV/m)]	Margin [dB]	Remark
1	104.136	39.2	-19.5	19.7	30.0	10.3	
2	960.083	29.7	-0.6	29.1	37.0	7.9	
3	231.945	32.3	-17.3	15.0	37.0	22.0	
4	67.575	29.5	-22.7	6.8	30.0	23.2	

--- Vertical Polarization (QP)---

No.	Frequency [MHz]	Reading [dB(uV)]	c.f [dB(1/m)]	Result [dB(uV/m)]	Limit [dB(uV/m)]	Margin [dB]	Remark
1	104.548	44.9	-19.3	25.6	30.0	4.4	
2	196.191	36.9	-18.7	18.2	30.0	11.8	
3	991.857	21.3	1.9	23.2	37.0	13.8	
4	30.000	20.4	-6.5	13.9	30.0	16.1	



Test Report No. : LBE060348

* QP : Quasi-peak, AV: Average

* Level (QuasiPeak or Average)

= Meter Reading(QP or AV) + Corr. (Antenna facor + Cable loss – Amp.gain)

* Margin = Limit – Result

4. Appendix

4.1 Test photography

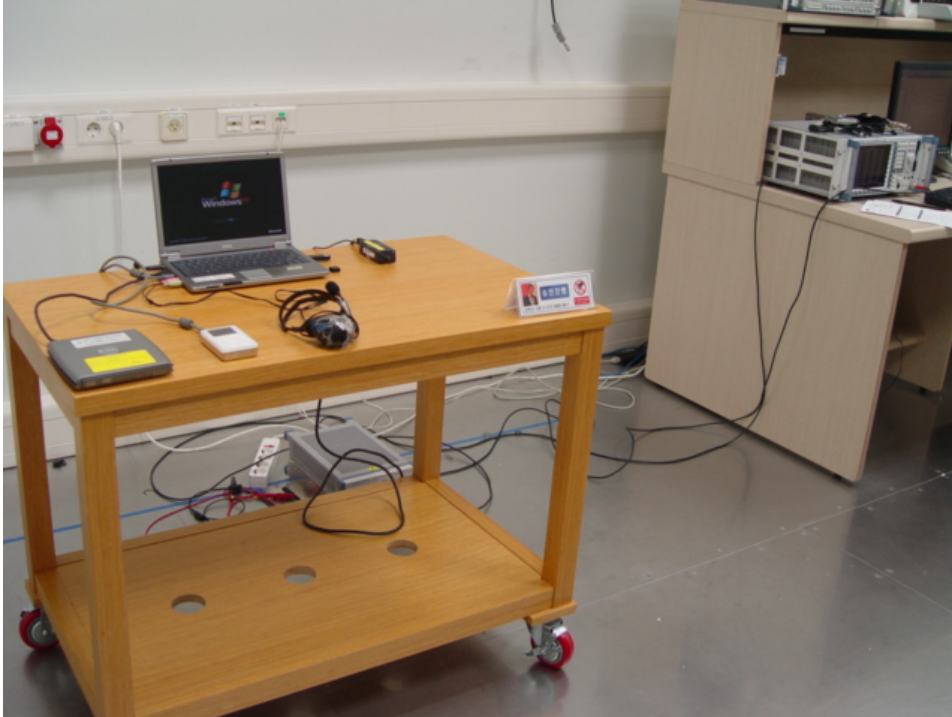

Picture 1. Conducted emission (Front)

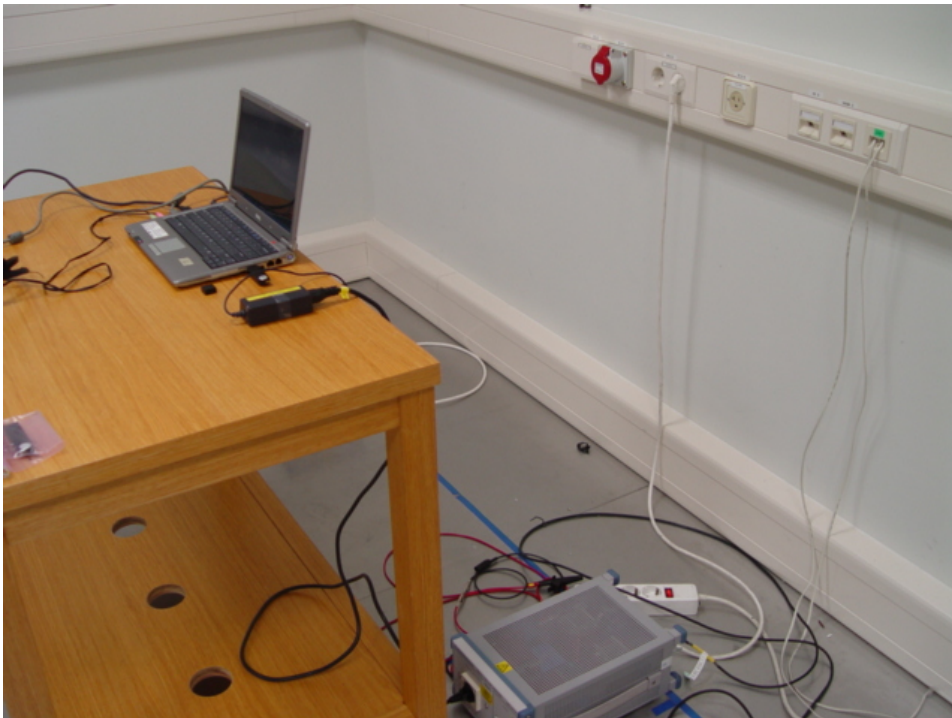

Picture 2. Conducted emission (Rear)

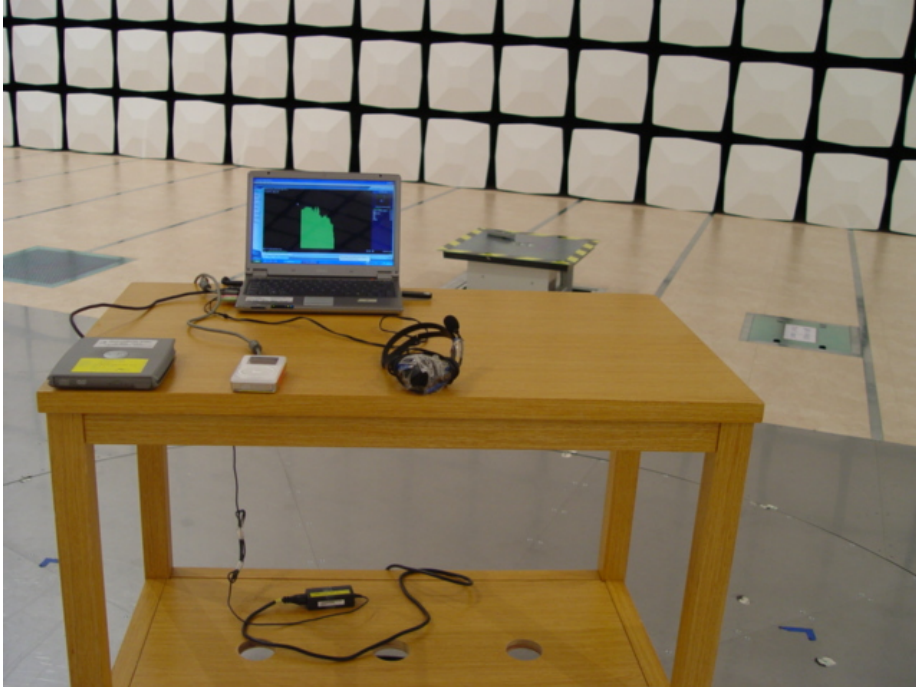

Picture 3. Radiated emission (Front)

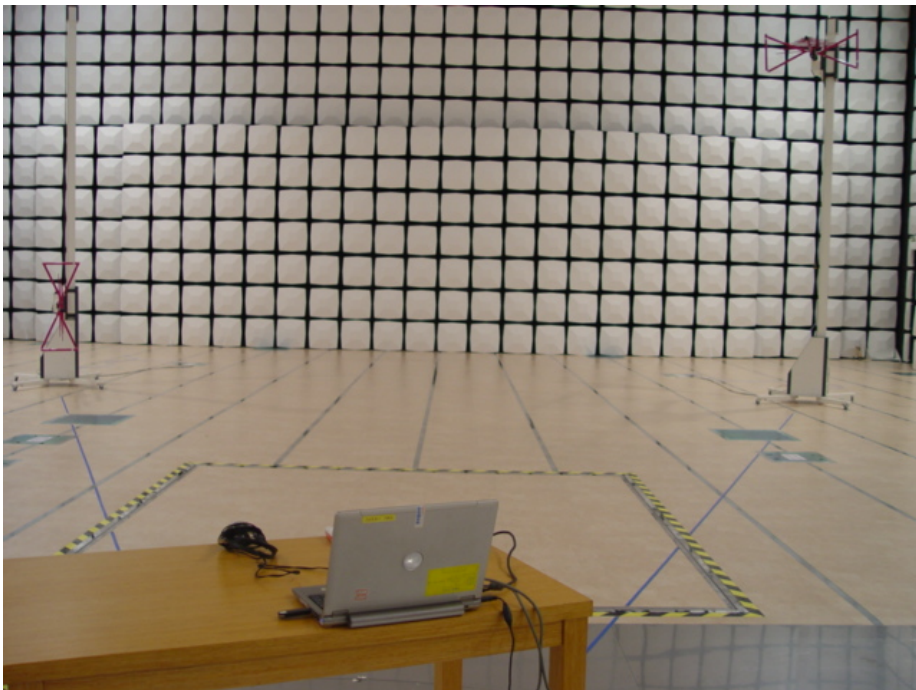

Picture 4. Radiated emission (Rear)

4.2 EUT photography



Picture 5. EUT (Top)



Picture 6. EUT (Bottom)

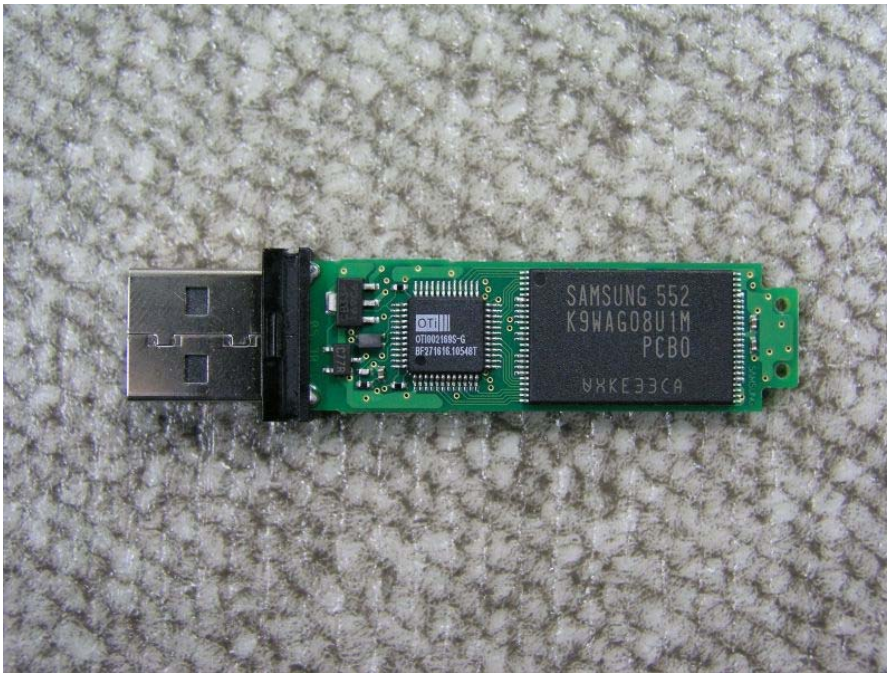

Picture 7. EUT (Inner - Top)



Picture 8. EUT (Inner - Bottom)

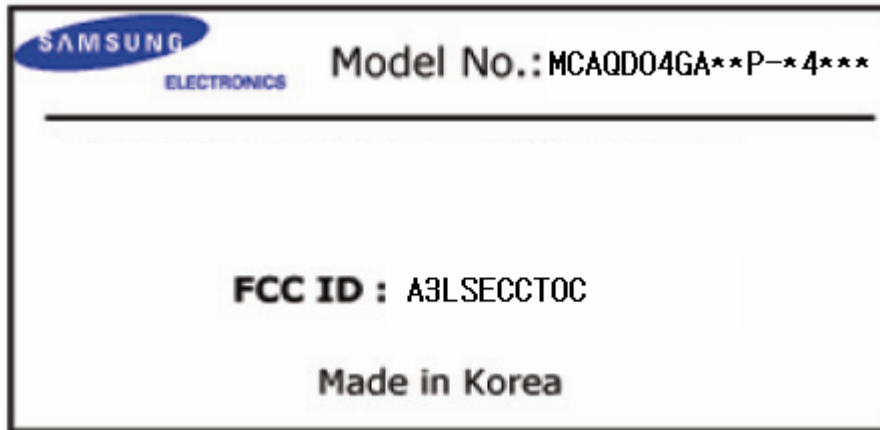

Picture 9. Label