

EMI TEST REPORT

SAMSUNG ELECTRONICS CO., LTD.

Product : **Notebook Computer**

Model No. : **SENS Pro 850**

FCC ID : **A3LS850**

DATE : **February 11, 1999**

SAMSUNG Reference NO. : 990209

This test report is to certify that the tested device properly complies with the requirements of FCC Rules and Regulations Part 15 Subpart B Unintentional Radiators. All tests necessary to show compliance to the requirements were and these results met the specifications requirement.

1. Applicant Name : SAMSUNG ELECTRONICS CO., LTD.
(Company name & Address) 416 Maetan 3 Dong, Paldal-Ku,
Suwon City, Kyungki Do, Korea,
441-742

2. Identification of tested device

2.1 FCC ID : A3LS850
2.2 Device Name : Notebook Computer
2.3 Brand (Trade Name) : SAMSUNG
2.4 Model Number : SENS Pro 850

3. Test Procedure and Items

3.1 AC Powerline Conducted Emissions Measurement : ANSI C63.4-1992
3.2 Radiated Emissions Measurement : ANSI C63.4-1992

4. Issued Date : February 11, 1999

TESTED BY :

N. C. Park
No-Cheon, PARK / Test Engineer

APPROVED BY :

T. J. Shin
Taek-Jeong, SHIN / Chief of EMC Lab.

TABLE OF CONTENTS

1. GENERAL INFORMATION
 - 1.1 Product Description
 - 1.2 Grants
 - 1.3 Tested System Details
 - 1.4 Test Methodology
 - 1.5 Test Facility

2. SYSTEM TEST CONFIGURATION
 - 2.1 Justification
 - 2.2 Video Mode Justification
 - 2.3 EUT Exercise Software
 - 2.4 Special Accessories
 - 2.5 Equipment Modification
 - 2.6 Test System configuration
 - 2.7 Photographs

3. CONDUCTED EMISSION DATA

4. RADIATED EMISSION DATA

5. LIST OF TEST INSTRUMENT

1. General Information

1.1 Product Description

The Samsung Electronics Co., Ltd. Notebook Computer Model SENS Pro 850(FCC ID :A3LS850)is based on the powerful pentium II processor(CPU 366MHz) and has internal clock speeds of 14.318, 16, 33, 66 and 100MHz. It can be operated from rechargeable battery pack or by 100-240V AC Adapter.

See attached SENS Pro 850 User's Guide for more information.

1.2 Grants

N/A

1.3 Test System Details

The FCC IDs for all equipment plus descriptions of all cables used with the tested system (including inserted cards which have grant) are:

FCC ID	DESCRIPTION (Model Name)	CABLE DESCRIPTION
A3LS850	EUT (SENS Pro 850)	-
A3LCST768	External Monitor (CST7687L)	Shielded interface
DZLCC	Serial Mouse (M-CG7)	Unshielded interface
GJJSKR-1032B	Keyboard (SKR-1032B)	Unshielded interface
N/A	AC Adaper (AD-6019)	Unshielded interface
N/A	USB Termination cable	Unshielded interface
A3LSMD750E	Mini-Dock(SMD-750EL)	Unshielded interface
DSI16XU222	Inkjet Printer (2225C)	Shielded interface
N/A	PCMCIA(SLOTS-2EA)FLASH MEMORY	-
N/A	TelePhone (SSP-2501)	Unshielded interface
N/A	Ear-set (-)	Unshielded interface

1.4 Test Methodology

Both radiated and conducted tests were performed according to the procedure in ANSI C63.4-1992. Radiated testing was performed at an antenna-to-EUT distance of three meters.

1.5 Test Facility

All test described in this report were performed by :
SAMSUNG ELECTRONICS CO., LTD.
EMC TESTING LABORATORY
416 Maetan 3 Dong, Paldal-Ku, Suwon City, Kyungki Do, Korea, 441-742
Open area test site (3 meter) and Shielded Room.

This test facility has been filed in FCC under the criteria in ANSI C63.4-1992.

2. SYSTEM TEST CONFIGURATION

2.1 Justification

The system was configured for testing in typical fashion (as a customer would use it), It has internal clock speeds of 14.318, 16, 33, 66 and 100MHz. And the EUT have various CPUs(266,300,333 and 366MHz CPU). The EUT has been checked with the optional Modem(SFM-1400LW, 56KBPS) installed. The EUT was investigated while operating at all speeds. The highest speed of 366MHz CPU was used for final testing as it was found to cause worst case emissions.

The EUT's video circuitry is capable of operating at a maximum non-interlaced resolution of 1024x768 pixels. The EUT was observed while scrolling a continuous stream for capital "H's" in the 1024x768 mode(both LCD 14.1" and External Monitor).

Comparing the test results with Mini-Dock and without Mini-Dock. The test result without Mini-Dock was found the worst case emissions. And so the final testing was performed without Mini-Dock. Samsung does intend to market this Mini-Dock as a separate unit. Therefore this Mini-Dock will not be supplied with the EUT.

The EUT was tested with a Samsung AC Adapter Model number AD-6019. Further details of cabling and configuration are shown in the test system configuration.

2.2 Video Mode Justification

The system was tested in 1024x768 highest resolution mode.
Since the 1024x768 resolution mode(LCD 14.1" TFT & External Monitor both in use) was found to be worst case, this mode was used to collect the included data.

2.3 EUT Exercise Soft ware

The EUT exercise program used during testing was designed to exercise the system in a manner similar to a typical use. This program was contained on the EUT's Hard Disk and CD-ROM Drv. Once loaded, the program sequentially exercise each system component in turn. The sequence used was : 1) serial "H"s scrolled to the LCD and Monitor; 2) copy series of "H"s characters to mass storage device.

3) print series of H characters to printer. Since the mouse and speaker are strictly input device, no data was transmitted to them during testing. They are, however, continuously scanned for data input activity.

2.4 Special Accessories

The Samsung AC adapter connect cable has a ferrite bead on the line as supplied by the manufacturer.

The ferrite specification that used on AC adapter connection cable.

The following is ferrite specification.

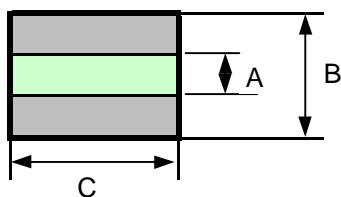

AC Adapter

A : 4.7mm

B : 9.8mm

C :24.5mm

2.5 Equipment Modifications

No equipment modifications were performed during testing.

2.6 Test System configuration

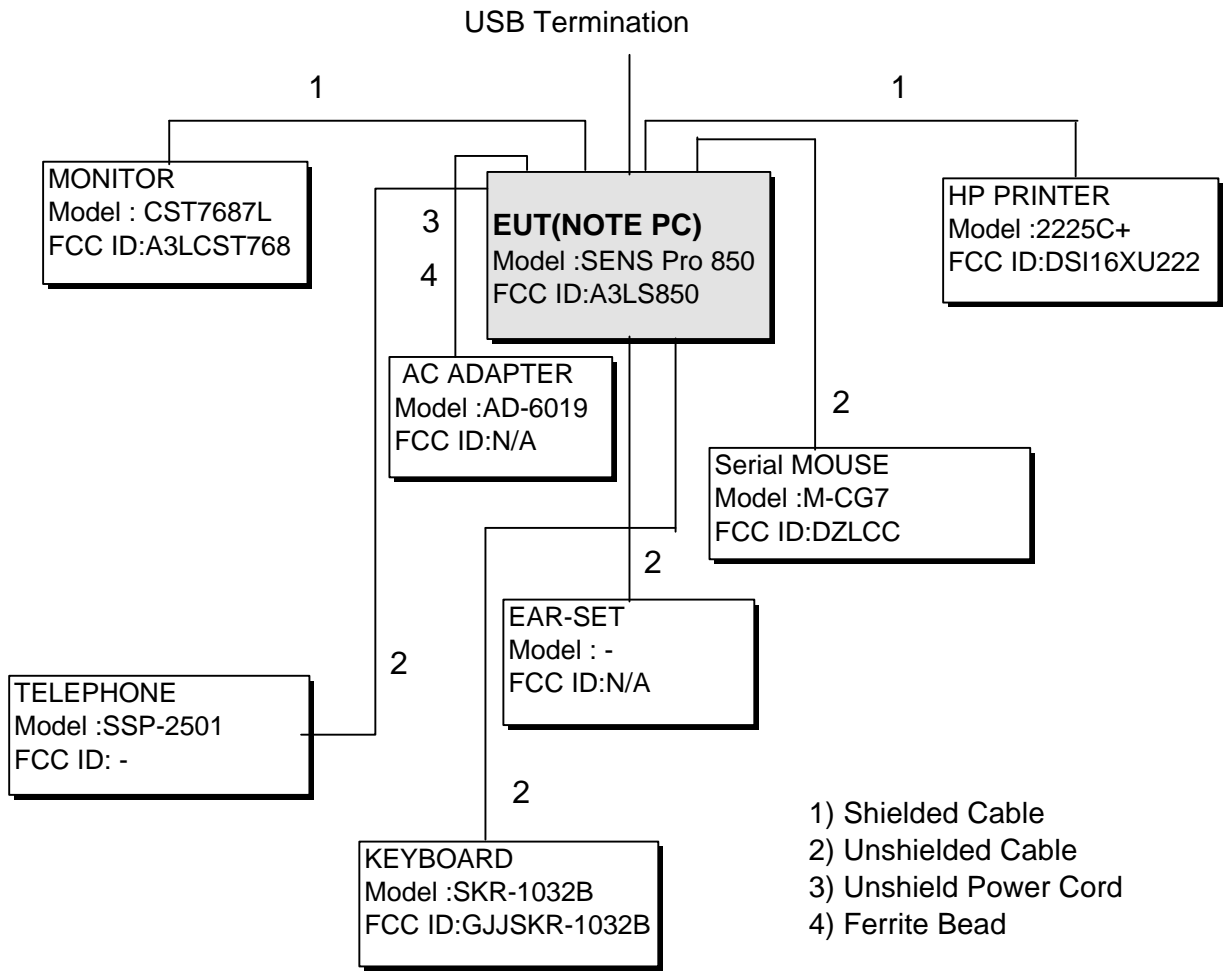

2.7 Photographs

Radiation(Front View)



Radiation(Rear View)

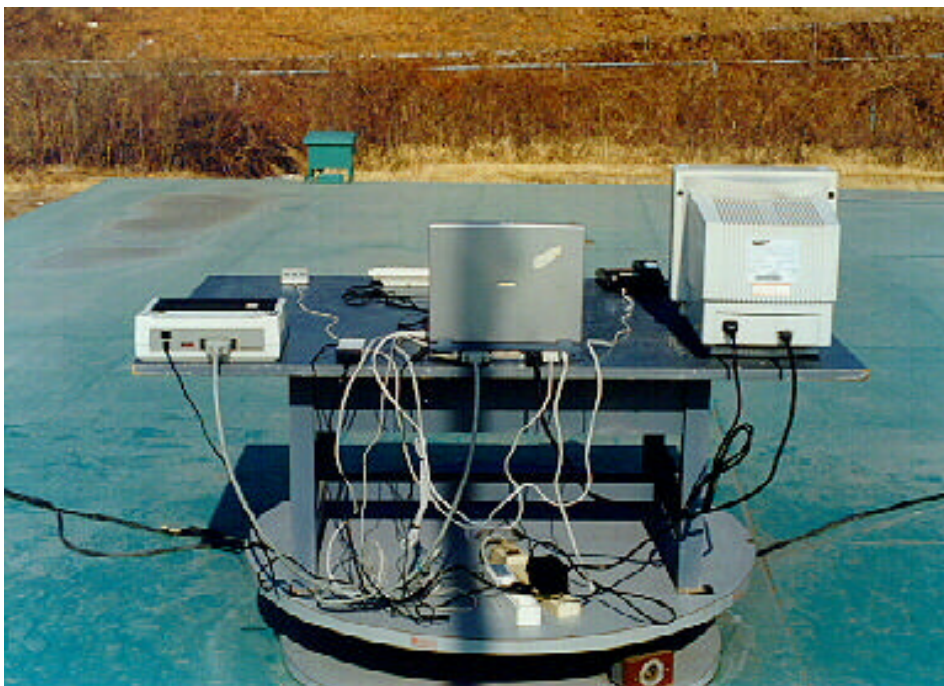

Conduction(Front View)



Conduction(Side View)

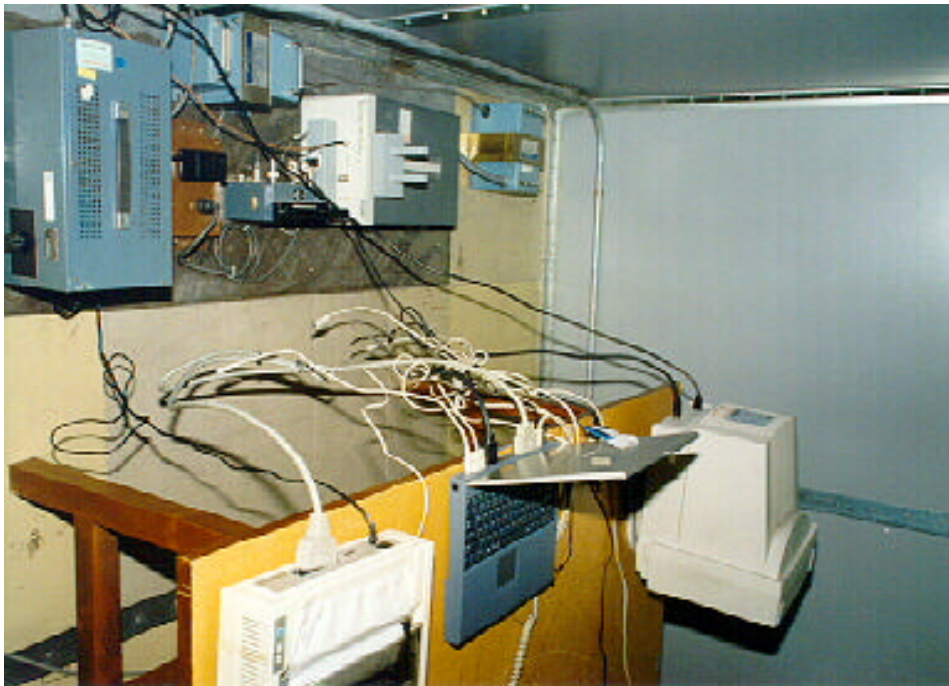

3. CONDUCTED EMISSION DATA

The initial step in collecting conducted data was to perform a quasi-peak scan over the measurement range using a spectrum analyzer.

Sample Calculation

Frequency : 0.712 [MHz]
 Meter Reading : 39.9 [dBuV]
 Factor of LISN : 0.1 [dB]

Then, Result is calculated as follows.

$$39.9 + 0.1 = 40 \text{ [dBuV]}$$

Test Data Sheet

Tested Frequency [MHz]	Meter Reading (Quasi-Peak) [A] [dBuV]	LISN Pol. [L1,L2]	Total Loss [B] [dB]	Results [A+B] [dBuV]	Limits [dBuV]	FCC Margin [dB]
0.712	39.9	L1	0.1	40	48	8
0.892	42.6	L2	0.1	42.7	48	5.3
1.372	41.2	L2	0.1	41.3	48	6.7
2.131	42.5	L2	0.2	42.7	48	5.3
3.534	40.2	L1	0.1	40.3	48	7.7
15.065	38.9	L1	0.2	39.1	48	8.9

4. RADIATED EMISSION DATA

The initial step in collecting radiated data was to perform a quasi-peak scan over the measurement range using a spectrum analyzer. All modes of operation were investigated and the worst-case emission are reported. All other emission are non-significant.

Sample Calculation

Frequency : 43.2 [MHz]
 Meter Reading : 18.2 [dBuV]
 Total of Loss : 13.5 [dB]

Then, Result is calculated as follows.

$$18.2 + 13.5 = 31.7 \text{ [dBuV]}$$

Test Data Sheet

Frequency Range [MHz]	Tested Frequency [MHz]	ANT Pol.	Meter Reading [A] [dBuV/m]	Total Loss [B] [dB]	Results [A+B] [dBuV/m]	FCC Margin [dB]	Limits [3m] [dBuV/m]
30 - 88	43.2	H	18.2	13.5	31.7	8.3	40.0
	58.4	H	20.9	10.1	31	9	
	61.4	H	25.1	9.6	34.7	5.3	
	66.9	V	26.5	9.3	35.8	4.2	
	78.3	H	24.1	9.3	33.4	6.6	
	84.7	V	25.3	9.5	34.8	5.2	
88 - 216	117.2	V	26.4	9.6	36	7.5	43.5
	137.7	H	26.1	9.5	35.6	7.9	
	172.6	H	23.3	10.9	34.2	9.3	
	182.3	H	22.6	11.3	33.9	9.6	
	199.8	H	27.3	12	39.3	4.2	
	214.7	H	24.3	12.6	36.9	6.6	
216 - 960	233.1	H	23.6	13.5	37.1	8.9	46.0
	240.6	V	27.2	13.7	40.9	5.1	
	247.4	V	27.7	13.9	41.6	4.4	
	300	V	25.5	16.6	42.1	3.9	
	325.7	H	25.2	16.7	41.9	4.1	
	358.1	V	24.8	17.3	42.1	3.9	
960 -	998.5	H	<6	28.2	-	-	54.0
	1277	H	<6	31.6	-	-	

[NOTE] "<" Means equal or less than

Receiving Antenna polarization : **Horizontal, Vertical**

5. LIST OF TEST INSTRUMENT.

Equipment	Model No.	Serial No.	Makers	Calibration Last calibration and Interval
Spectrum analyzer	8566B	2611A02672	H.P	98/ 9/21, 12Months
Quasi-peak adapter	85650A	2521A00687	H.P	98/ 9/21, 12Months
RF Preselector	85685A	2602A00224	H.P	98/ 9/21, 12Months
Field strength meter	ESS	844861/005	R & S	98/ 3/16, 12Months
	ESVP	860688/015	R & S	98/ 9/21, 12Months
L.I.S.N	3825-2	9208-1981	EMCO	98/ 9/ 5, 12Months
Double Ridged WaveGuide	3115	4028	EMCO	98/10/ 2, 12Months
Bi-conical Antenna	3110B	2012	EMCO	98/12/ 1, 12Months
Log-periodic Antenna	3146A	1320	EMCO	98/12/ 1, 12Months