

Notice

The information within this manual is subject to change without notice. The manufacturer shall not be held liable for technical or editorial errors or omissions contained in herein; nor for incidental or consequential damages resulting from the furnishing, performance or use of this material.

No part of this publication may be reproduced, stored in a retrieval system, or transmitted, in any form or by any means, mechanical photocopying, recording or otherwise, without the prior written permission of the manufacturer.

Product names mentioned herein are for identification purposes only, and may be trademarks and/or registered trademarks of their respective companies.

1998. All rights reserved

Federal Communications Commission (FCC)

This device complies with Part 15 of the FCC Rules. Operation is subject to the following two conditions:(1) this device may not cause harmful interference, and (2) this device must accept any interference received, including interference that may cause undesired operation.

NOTE:

This equipment has been tested and found to comply with the limits for a Class B digital device pursuant to Part 15 of the FCC Rules. These limits are designed to provide reasonable protection against harmful interference in a residential installation. This equipment generates, uses and can radiate radio frequency energy and if not installed and used in accordance with the instructions, it may cause harmful interference in a particular installation. If this equipment does cause harmful interference to radio or television reception, which can be determined by turning the equipment off and on, the user is encouraged to try to correct the interference by one or more of the following measures:

- Reorient or relocate the receiving antenna.
- Increase the separation between the equipment and receiver.
- Connect the equipment into an outlet on a circuit different from that to which the receiver is connected.
- Consult the dealer or an experienced radio/TV technician for help.

If necessary, the user should consult the dealer or an experienced radio/television technician for additional suggestions. The user may find the following booklet helpful: "Something About Interference." This is available at FCC local regional offices. Our company is not responsible for any radio or television interference caused by unauthorized modifications of this equipment or the substitution or attachment of connecting cables and equipment other than those specified by our company. The correction will be the responsibility of the user. Use only shielded data cables with this system.

CLASS 1 LASER PRODUCT

CAUTION

The laser beam used by this CD-ROM drive unit can be harmful to the eyes. Do not attempt to open the unit. All service procedures should be performed by an authorized dealer or distributor.

WARNING

Never use any optical instruments in conjunction with this unit. To do so will greatly increase the hazard to your eyes.

ADVARSEL

USYNLIG LASERSTRÅLING VED ÅBNING, NÅR SIKKERHEDSAFBRYDERE ER UDE AF FUNKTION.

SE IKKE IND I STRÅLEN - HELLER IKKE MED OPTISKE INSTRUMENTER.

ADVARSEL

USYNLIG LASERSTRÅLING NÅR DEKSEL ÅPNES OG SIKKERHEDSLÅS BRYTES. STIRR IKKE INN I STRÅLEN ELLER SE DIREKTE MED OPTISKE INSTRUMENTER.

LUOKAN 1 LASERLAITE.

VAROITUS!

LAITTEEN KÄYTTÄMINEN MUULLA KUIN TÄSSÄ KÄYTTÖOHJEESSA MAINITULLA TAVALLA SAATTA A ALTISTAA KÄYTTÄJÄN TURVALLISUUSLUOKAN 1 YLITTÄVÄLLE NÄKYMÄTTÖMÄLLE LASERSÄTEILYLLE.

KLASS 1 LASERAPPARAT.

VARNING

OM APPARATEN ANVÄNDS PÅ ANNAT SÄTT ÄN I DENNA BRUKSANVISNING SPECIFICERATS, KAN ANVÄNDAREN UTSÄTTAS FÖR OSYNLIG LASER-STRÅLNING, SOM ÖVERSKRIDER GRÄNSEN FÖR LASERKLASS 1.

Labels appearing on the drives:

CAUTION - INVISIBLE LASER RADIATION WHEN OPEN. AVOID EXPOSURE TO BEAM.

VORSICHT! UNSICHTBARE LASERSTRAHLUNG TRITT AUS, WENN DECKEL GEÖFFNET. NICHT DEM STRAHL AUSSETZEN!

VARNING - OSYNLIG LASERSTRÅLNING NÄR DENNA DEL ÄR ÖPPNAD. STRÅLEN ÄR FARLIG.

ADVARSEL - USYNLIG LASERSTRÅLING VED ÅBNING. UNDGÅ UDS/ETTELSE FOR STRÅLING.

CLASS 1 LASER PRODUCT LASERSCHUTZKLASSE 1 PRODUKT TOEN 60825

Important Safety Instruction

Read all of these instructions, and save these instructions for later use.

- Follow all warnings and instructions marked on the product. Unplug this product from the wall outlet before cleaning. Do not use liquid cleaners or aerosol cleaners. Use a damp cloth for cleaning.
- Do not use this product near water. Never spill liquid of any kind on the product.
- Do not place this product on an unstable cart, stand, or table.
- Slots and openings in the cabinet are provided for ventilation, to ensure reliable operation of the product on a bed, sofa, rug, or other similar surface. This product should never be placed near or over a radiator or heat register. This product should not be placed in a built-in installation unless proper ventilation is provided.
- Before connecting this product to a power source, check the required voltage and frequency match the available power source.
- This computer is powered by an internal battery pack or by an external AC power source through an external AC adapter. Use of another battery pack or external AC adapter may present risk of fire or explosion.
- This product is equipped with a 2-wire type plug. If you are unable to insert the plug into the outlet, contact your electrician to replace your obsolete outlet.
- Do not allow anything to rest on the power cord.
- Do not place this product in a location where someone may trip over the cord.
- If an extension cord is used with this product, make sure that the total of the ampere ratings on the products plugged into the extension cord do not exceed the extension cord ampererating.
- Never push objects of any kind into this product through the cabinet slots, as they may touch dangerous voltage points or short out parts; that could result in a risk of fire or electric shock.
- Except as explained elsewhere in this manual, do not attempt to service this product yourself.
- Handle battery with care. If dropped, it may be damaged.
- Do not allow the battery to be exposed to direct sunlight for extended periods of time.
- Do not attempt to disassemble the battery. If the battery is disassembled and the electrodes are exposed to outside, the battery may generate heat and smoke by chemical reaction.
- Do not expose the battery to moisture or chemicals.
- Charge the battery only as described in this document.
- Do not short circuit the battery terminals as the resulting high currents can damage the

battery.

- The battery should not be used to power other products.
- Do not dispose of a used battery in a fire or incinerator, as an explosion may result.
- The battery should be recycled.
- Do not subject the battery to temperature less than -20 degrees Centigrade or greater than 50 degrees Centigrade.
- Unplug this product from the wall outlet and refer problems to the service representative under the following conditions:
 - When the power cord or plug is damaged or frayed.
 - If liquid has been spilled into product.
 - If the product has been exposed to rain or water.
 - If the product does not operate normally when the operating instructions are followed, adjust only those controls that are covered by the operating Instructions. Improper adjustment of other controls may result in damage.

Table of Contents

Using Your Documentation	1
Special Features of the User's Manual	1
Using the Software User Documentation	2
Introducing Your Computer	3
Using Your Computer for the First Time	5
Attaching the AC Adapter	5
Turning On the Computer	6
Understanding POST	7
Adjusting the LCD Display	8
Turning Off Your Computer	8
Restarting Your Computer	8
Tips for Using Your Computer	9
Traveling with Your Computer	10
Handling Spills	11
Storing the Computer for Long Periods	11
Using the Keyboard	13
Using the Numeric Keypad	14
Using Special Function Keys	15
Using the Touchpad	17
Reading the System Status Lights	19
Connecting Peripheral Devices	21
Connecting the Floppy Drive to the Floppy Connector	23

Using the SmartBay	25
Using the Floppy Drive	27
Using the CD-ROM Drive	29
Using the Hard Drive	32
Removing the Hard Drive	32
Installing a Hard Drive	33
Using the Battery	34
Charging the Battery	34
Safely Using the AC Adapter and Batteries	35
Removing and Installing the Battery	35
Monitoring the Battery Charge	36
Using the Battery Gauge	37
Using the Main Battery Lights	38
Using PowerProfiler to Monitor the Battery	38
Battery Warnings	39
Using System Setup	40
Starting System Setup	41
Main Menu	43
Advanced Menu	45
Security Menu	48
Power Menu	49
Boot Menu	51
Exit Menu	52
Using System Security	54
System Passwords	54
Creating a Password	54
Deleting a Password	55

Requiring a Boot Password	56
Locking the Hard Drive Boot Sector	56
Locking the Floppy Drive	56
Locking the Keyboard	56
Using Power Management Options	57
Non-Turbo Mode	57
Standby Mode	58
Suspend Mode	58
Suspend Mode Precautions	59
Using PowerProfiler	60
Creating a Save to Disk Partition	62
Changing the Video Configuration	65
Resolution and Color Depth	65
Configuring Display Features	66
Selecting a Monitor Type	67
Changing Color Depth and Resolution	67
Working with PC Cards	69
Maintaining PC Cards	69
Using PC Cards	70
Windows 98	71
Windows NT	71
Troubleshooting	73
Operating Problems	73
Infrared Problems	75
Using Options	76
Auto/Airline Adapter	76
Battery Pack	77
Hard Drives	77

Memory Modules	77
Before You Install Memory	77
Installing a Memory Module	78
Battery Cradle	81
External Numeric Keypad	82
CD-ROM Drive and Floppy Cable	82
Docking Options	82
Specifications	83
Abbreviations	85
Glossary	88

Using Your Documentation

Congratulations on your purchase the note book computer! Whether you are new to using a portable computer or are an experienced user, the computer documentation can help you get the most from your computer.

When you need more in-depth information, turn to your online *User's Manual*.

Special Features of the User's Manual

Three types of messages with icons appear in the manual:



A note informs you of special circumstances.



A caution warns you of possible damage to equipment.



A warning indicates the possibility of personal injury.

Keys that you need to press to perform certain functions are shown in the manual enclosed in angle brackets. For example,

<Ctrl>

indicates the control key (Ctrl on the computer's keyboard).

If you need to press two keys at the same time, the key names are shown joined by a plus sign. For example,

<Fn+F11>

means that you should press the Fn key and hold it and then press the F11 key.

If you are new to using computers, see the Glossary. The Glossary explains general computing terms that are used in this manual and tells you about some of the differences between portable computers and desktop computers.

Using the Software User Documentation

Your computer shipped from the factory with several software programs installed. The software may include its own online or printed documentation. Refer to the documentation or the Help options in the software for more information.

Introducing Your Computer

Your notebook computer is a lightweight portable computer that includes features to meet your computing needs at home or on the road.

Figures 1 through 3 show you the features of your computer.

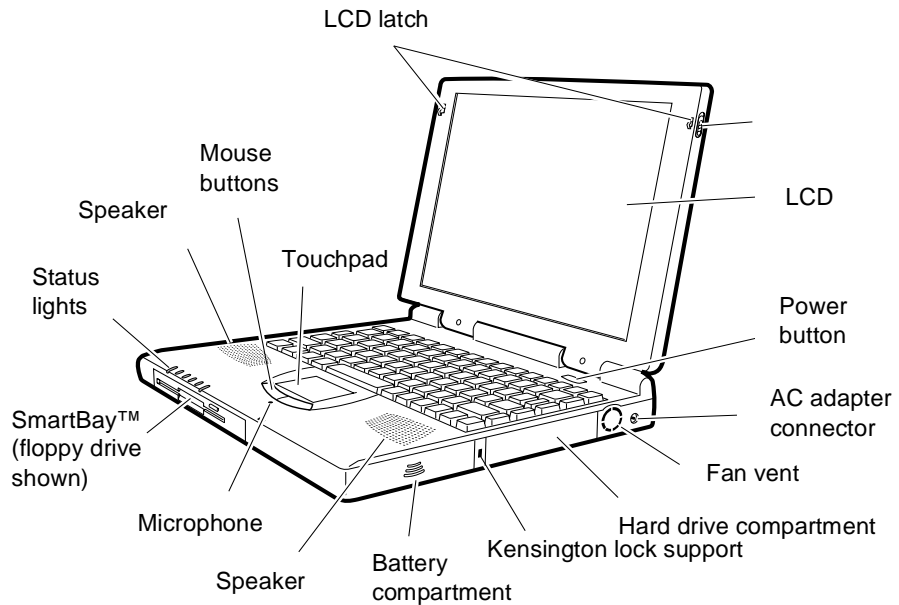

Figure 1. Front View of Computer

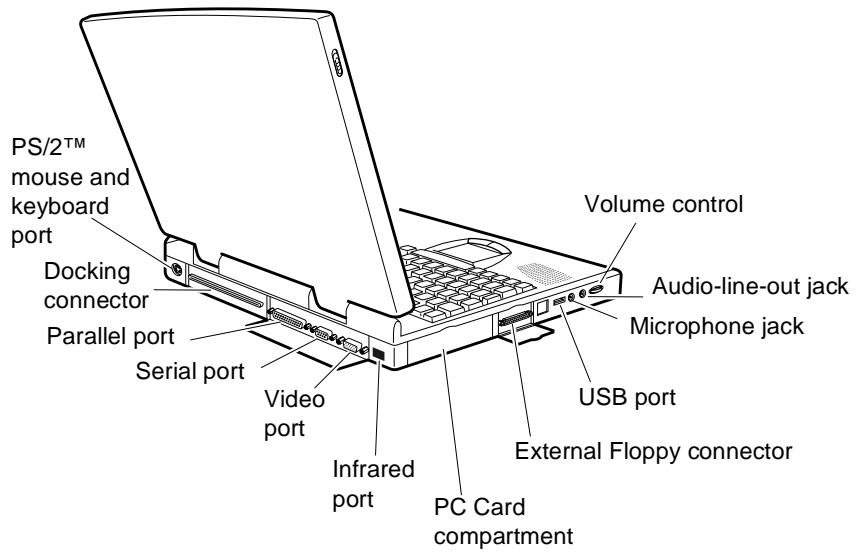

Figure 2. Back View of Computer

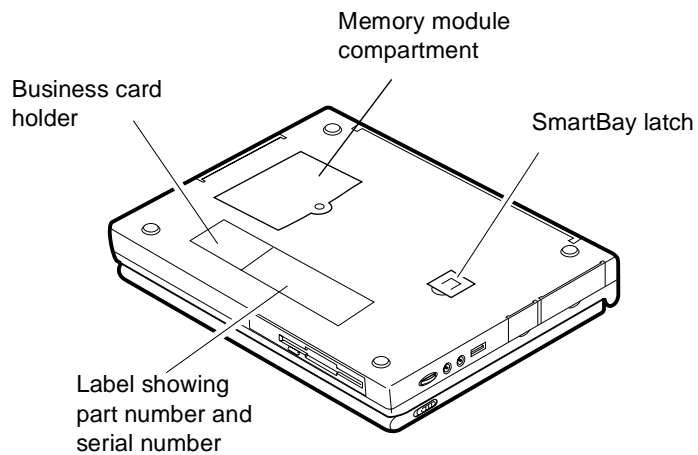

Figure 3. Bottom View of Computer

Using Your Computer for the First Time

This section gives you detailed information on using your computer for the first time.

Attaching the AC Adapter

Your computer runs on power from the battery that came installed in the computer or from an electrical outlet. The first time that you use your computer, fully charge the battery by attaching the AC adapter to the computer and to an electrical outlet.



All batteries lose their charge if they sit unused for an extended time period. When not used, your Ascentia M battery can discharge fully in 2 to 3 months. The battery may have discharged in the time it took for the computer to go from the factory to you.

To attach the AC adapter:

1. Plug the AC adapter into the power connector on the right side of the computer (Figure 4).
2. Connect the power cord to the AC adapter and then to an electrical outlet.

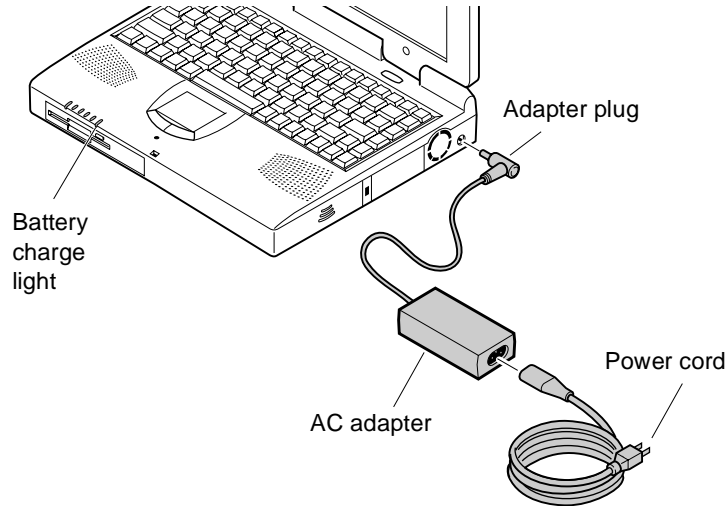

Figure 4. Connecting the AC Adapter

The battery starts charging as soon as you plug the AC adapter into an electrical outlet. The battery charges faster if the computer is turned off during charging.

If the battery is fully depleted and the computer is turned off, the battery charges in about 3 hours. If the computer is turned on, the battery charges in about 6 hours. When the battery is charging, the battery charge light is amber. When the battery is fully charged, the light turns green.

See “Using the Battery” on page 34 for more information on using your computer’s battery.

Turning On the Computer

To turn on the computer’s power for the first time:

1. Slide the LCD cover latch to the right and hold it.
2. Lift up the LCD cover.

3. Press and then release the power button (Figure 5).

The power light is on when the computer's power is on.

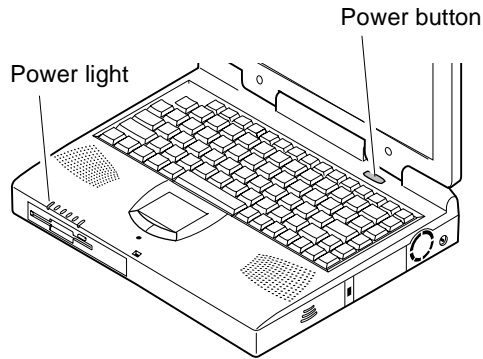

Figure 5. Turning On the Computer's Power

Understanding POST

When you turn on your computer, a routine called POST automatically runs to test the computer components. The manufacturer logo appears on the screen during POST, if you press the *ESC* key while the manufacturer logo is displayed you will see several messages on the screen (see “Boot Menu” on page 51 for information on disabling the logo screen). After POST is successfully completed, the computer beeps once.

Screen messages are built into the computer to report both normal and abnormal system conditions. If an error message appears, take any action suggested in the message. If the message identifies the error condition but does not suggest any corrective action, write down the message and contact manufacturer or an authorized service center for assistance.

Adjusting the LCD Display

You may wish to adjust the LCD display when you begin using your computer. A TFT LCD does not require adjustment for contrast because the contrast is set to remain at maximum.

To adjust the brightness of the LCD:

- Press <Fn+Right Arrow> to increase the display brightness.
- Press <Fn+Left Arrow> to decrease the display brightness.

Turning Off Your Computer



If your computer has a Windows operating system, turn off your computer by performing the shutdown procedure described in this section. Otherwise, you may lose data.

To turn off the computer:

1. Click Start on the taskbar.
2. Click *Shut Down*.
3. Select the shut down option.
4. Click OK or Yes.
 - If the operating system is Windows 98, the computer turns off.
 - If the operating system is Windows NT, you receive a shutdown message and must press the power button to turn off the computer.

Restarting Your Computer

You may need to restart (reboot) your computer when installing hardware or software or if the computer does not respond to your input. A warm (or soft) boot prompts you to save your files, turns off the computer, and then restarts the computer. A cold boot turns off the computer without saving your files.



Do not perform a cold boot unless your keyboard and touchpad have no effect and you cannot perform a warm boot.

When you perform a cold boot, you lose data unless it was saved to a storage medium.

To perform a warm (or soft) boot:

1. Click the Start button on the taskbar.
2. Click *Shut Down*.
3. Select *Restart the Computer*.
4. Click the Yes button.
5. Save your files if prompted. Your computer reboots.

You can also perform a soft boot by saving your files and pressing <Ctrl+Alt+Del> and then clicking on *Shut Down*.

You can perform a cold (or hard) boot by pressing the power button to turn the computer off, waiting five seconds, and then pressing the power button to turn the computer on.

Tips for Using Your Computer

The following information helps you avoid potential problems as you use your computer:



Do not try to disassemble your computer. Opening the system chassis voids your warranty. Only an authorized service center can replace or add any parts inside the chassis.

- Follow all the instructions and cautions in your computer user documentation.
- The LCD has a polarized surface and can be damaged easily. To prevent damage, avoid touching the screen.
- Use only approved AC adapters, and memory modules.

- Because a portable computer is small and has restricted air flow around components, it is more likely to overheat than a desktop computer. A fan inside your computer helps to eliminate some heat. Make sure the fan vent on the side of your computer is not blocked when you use the computer. (See Figure 1 on page 3 for the location of the vent.) Occasionally check the vent and remove any accumulated dust on the outside.
- Avoid using or storing the computer in extremely hot or cold areas, such as a car on a hot day. Keep the computer away from heaters and out of direct sunlight. Exposure to excessive heat may damage computer components. If you have left your computer in a hot place, let it cool down slowly to room temperature (with the LCD panel open) before using it.
- Do not remove the memory-module compartment door, or try to install a memory module when the computer is on. (See Figure 3 for the location of the door.)
(For information on installing memory modules, see “Memory Modules” on page 77.)
- Set up your computer work area to avoid physical strain. Sit with your back straight and supported by your chair. Adjust your chair or work table so that your arms and wrists can remain in a relaxed position, parallel with the floor. Avoid bending or twisting your wrists as you work. Your hands should “float” slightly above the keyboard. Refer to a book on office ergonomics for more information on setting up your work area.
- Take frequent breaks from working at the computer to rest your eyes and stretch your muscles.
- Remember to save your data files frequently and to make backup copies of your files.

Traveling with Your Computer

If you are traveling by airplane, follow these tips:

- Take the computer with you as carry-on luggage. Do not check the computer with your baggage.
- Allow the computer and disks to go through the X-ray security devices. Do not hand-carry disks through the walk-through metal detectors, which can cause loss of data.

- Make sure that the battery is charged or the AC adapter is easily accessible. You may be required to turn on the computer for airport security personnel.
- Be prepared to turn off the computer during take off and landing.
- Contact your airline for information about using an optional airline adapter to power your computer while traveling by airplane.

Handling Spills

Do not spill anything on your computer. The best way to avoid spills is to avoid eating and drinking around your computer. If you do spill something on your computer, turn off your computer, unplug it immediately, and do the following:

- If you spill liquid on the keyboard, drain as much of the liquid from the keyboard as possible. Be careful not to let the liquid drip onto the LCD panel. Allow the system to dry for several days before trying to use it.
- If you spill liquid on an external keyboard or keypad, unplug it and drain as much of the liquid as possible. Allow the keyboard to sit at room temperature for a full day before trying to use it.



Sweet liquids leave a sticky residue that may jam the keyboard despite your efforts to dry it.

- If you spill liquid on the LCD panel, clean it immediately with a soft cloth and denatured alcohol. Do not use water, window cleaner, acetone, aromatic solvent, or dry, rough towels to clean it.



Some liquids damage the polarized LCD screen. If your screen is damaged, contact your authorized manufacturer's service center for a replacement.

Storing the Computer for Long Periods

If possible, leave the AC adapter connected to the computer when the computer is not in use. This helps extend the life of the battery and keeps the battery fully charged.

If you will not be using the computer for an extended period of time (a month or more), you should charge the battery until it is completely full. After you have done so, remove the battery from the unit.

Using the Keyboard

Your computer has an 87/88-key keyboard (Figure 6). By pressing designated key combinations, you can have access to all the key functions of a full-sized keyboard.

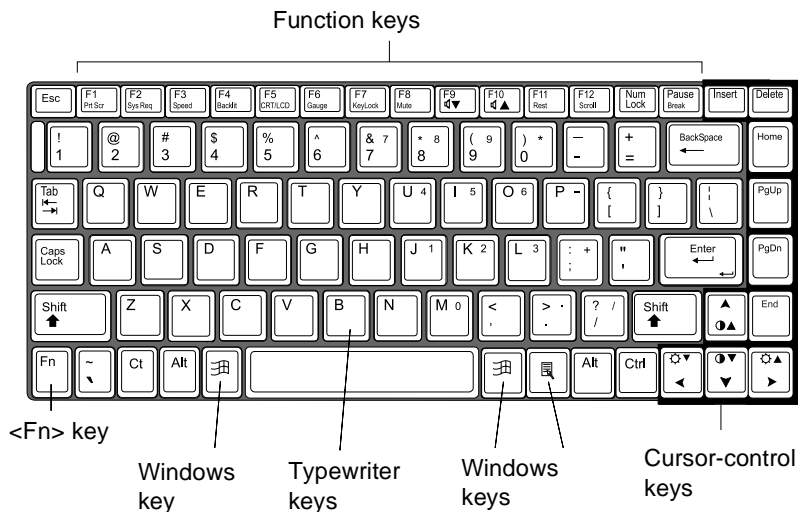

Figure 6. Keyboard



Although the layout of the keys on your computer's keyboard is different from that on a desktop computer's keyboard, the keyboard feels like a full-sized keyboard when you use it. The distance between the keys (the pitch) is the same as on a full-size keyboard (19 mm). The travel, or space the key goes down when pressed, is also the same (3 mm).

The keys on the keyboard can be grouped into the following categories:

- Full-sized typewriter keys are arranged like a standard typewriter keyboard and are used for text entry.

- Function keys, when pressed together with the <Fn> key, enable special functions.
- Cursor control keys move the cursor. They may perform other functions, depending on your software.
- Windows keys open Windows menus and perform other special functions.

To clean the computer keyboard, use slightly damp cotton swabs. Scrub the keys and the surface around the keys. Do not allow liquid to drip into the keyboard or you may damage the keyboard.

Using the Numeric Keypad

Your keyboard includes a numeric keypad, which is a group of keys that you can set to type numbers and mathematical symbols, such as the plus sign (Figure 7). A number or symbol on the right corner of each keypad key shows its numeric function.

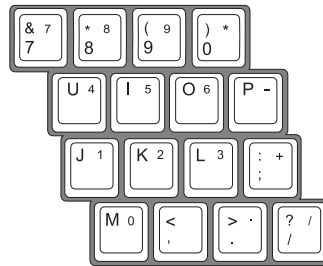

Figure 7. Numeric Keypad

Press <Num Lock> to turn on the embedded numeric keypad. The numeric functions of the keypad are enabled and the Num Lock light turns on.



While the numeric functions are enabled, you can temporarily return a key to its normal function by pressing <Fn> and the key. For example to type the letter *m*, press <Fn+m>.

To turn the numeric keypad off, press <Num Lock> again. The Num Lock light turns off.

Using Special Function Keys

The <Fn> key activates special functions when it is pressed in combination with another key. Table 1 shows the special key combinations.

Table 1. Description of Special Function Keys

<Fn> Key Combination	Function
<Fn+F1>	<i>Print screen:</i> In Windows 98 or Windows NT, takes a picture of the open screen and puts it on the clipboard.
<Fn+F2>	<i>System request:</i> Reserved for use in software programs.
<Fn+F3>	<i>Speed:</i> Enables and disables the Battery Power Saving mode. This key combination functions only when the computer is run from the battery. The options are Turbo and Non-turbo. Press <Fn+F3> to change the Battery Power Saving mode to their next settings. Press <Fn+F3> again to return the Power Saving mode to their previous settings. An icon of a dripping water faucet indicates that Battery Power Saving mode is Non-turbo mode.  An icon of a water faucet with water running at full force indicates that Battery Power Saving mode is Turbo mode.  This key combination changes Battery Power Saving modes only until you turn your computer off and then back on again.
<Fn+F4>	<i>Backlight:</i> Turns the LCD display off. Press any key (except the <Fn> key) to turn the LCD display back on.
<Fn+F5>	<i>CRT/LCD:</i> Switches the display between the LCD, the external monitor, and simultaneous display on both the LCD and the external monitor.

<Fn+F6>	<i>Gauge</i> : Displays the battery gauge in the upper-right corner of your screen. The gauge closes in a few seconds. (See “You can monitor the charge of the battery pack installed in your computer through the battery gauge.” on page 37 for more information on the battery gauge.)
<Fn+F7>	<i>KeyLock</i> : Locks the keyboard and activates password protection. Type your password and press <Enter> to unlock the keyboard. The <Fn+F7> key combination has no effect unless a password is enabled in System Setup. The Num Lock, Caps Lock, and Scroll Lock lights blink when the keyboard is locked.
<Fn+F8>	<i>Mute</i> : Turns the audio output on and off.
<Fn+F9>	<i>Volume down</i> : Decreases the audio volume.
<Fn+F10>	<i>Volume up</i> : Increases the audio volume.
<Fn+F11>	<i>Rest</i> : Puts the computer into rest or suspend mode. To resume normal operation from rest, press the power button. (See “Power Menu” on page 49 for more information about the rest mode.)
<Fn+F12>	<i>Scroll</i> : In some applications, sets the cursor-control keys to scroll the page up or down while the cursor position does not change. Pressing <Fn+F12> again turns off the scrolling function.
<Fn+Up Arrow>	<i>Contrast up</i> : Increases the LCD contrast. Contrast adjustment is not needed on a TFT LCD.
<Fn+Down Arrow>	<i>Contrast down</i> : Decreases the LCD contrast. Contrast adjustment is not needed on a TFT LCD.
<Fn+Right Arrow>	<i>Brightness up</i> : Increases the LCD brightness.
<Fn+Left Arrow>	<i>Brightness down</i> : Decreases the LCD brightness.

Using the Touchpad

Your computer is equipped with the SmartPoint™ touchpad, which is an integrated-pointing device that is used to perform standard mouse functions (Figure 8). The touchpad is an advanced and reliable pointing device that works with a touch of your finger.

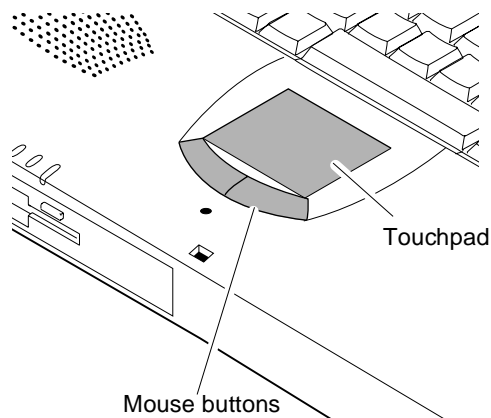

Figure 8. Touchpad

To use the touchpad:

- Place your finger on the pad and move your finger in the direction you want the cursor to move. The faster you move your finger, the faster the cursor moves across the screen.
- Roll your finger from side to side to move the cursor short distances.
- Quickly tap your finger on the touchpad to click an item.
- Tap your finger twice to double-click an item.
- Tap and drag your finger on the touchpad to click and drag an item.
- Press on the touchpad gently. The touchpad responds to light pressure.

You can also use the buttons at the bottom of the touchpad in the same way you use standard mouse buttons.

For information on attaching and using another pointing device or keyboard with your computer, see “Connecting Peripheral Devices” on page 21.

Reading the System Status Lights

System Status lights show the status of computer functions. The lights appear on the left edge of the computer (Figure 9). Table 2 describes the meaning of the lights.

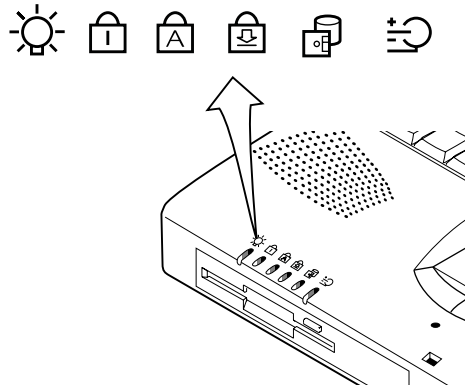







Figure 9. System Status Lights

Table 2. System Status Lights

Icon	Function of Light
	<i>Power light:</i> Light is on when the computer's power is on. The light blinks once every second when the battery is low. The light blinks once every three seconds when the system is in rest mode.
	<i>Num Lock light:</i> Light is on when the embedded numeric keypad is activated. See "Using the Numeric Keypad" on page 14 for a description of the keypad.
	<i>Caps Lock light:</i> Light is on when the caps lock function is activated. When the function is activated, all alphabetic characters you type will be in upper case.
	<i>Scroll Lock light:</i> Light is on when the scroll lock function is activated. The scroll lock function affects cursor movement and text scrolling in some applications. This is a software specific key. Refer to the appropriate software manuals for a description of the <Scroll> key.
	<i>Drive light:</i> Light is on when the hard drive or floppy drive is being accessed. Do not turn your computer off when this light is on. When the light is amber, the floppy drive is being accessed. When the light is green, the hard drive is being accessed. For a CD-ROM drive, check the light on the drive itself to see if the drive is being accessed.
	<i>Battery charge light:</i> Light gives information about the battery charge when the AC adapter is connected. When the battery is charging, the light is amber. When the battery is fully charged, the light turns green.

Connecting Peripheral Devices

The connectors on your computer enable you to attach peripheral devices to the computer (Figure 10).



Turn off your computer before you connect a peripheral device. Connecting a peripheral device with your computer turned on may seriously damage the device or your computer.

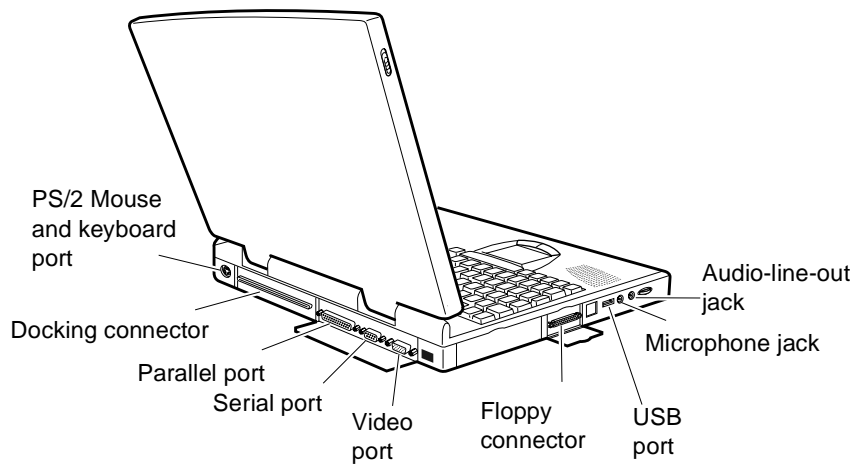









Figure 10. Peripheral Connectors

Table 3 shows the icons located near each connector and tells you the devices that you can attach to the connectors.

Table 3. Connecting Peripheral Devices

Icon	Connector
	<i>Audio-line-out jack:</i> Connect stereo headphones or speakers to this jack. Speakers connected to this jack override the onboard speakers.
	<i>Microphone jack:</i> Connect an external microphone to this jack. A microphone connected to this jack overrides the internal microphone.
	<i>USB port:</i> Connect USB devices to this port. USB input/output devices include keyboards, pointing devices, and monitors.
	<i>Floppy connector:</i> Connect one end of the floppy cable to this connector and the other end to the floppy drive to use the drive outside of the SmartBay. See “Connecting the Floppy Drive to the Floppy Connector” on page 21 for more information.
	<i>Video port:</i> Plug the interface cable of an external monitor into this 15-pin connector and then plug the monitor power cord into a grounded outlet.
	<i>Serial port:</i> Plug a serial device, such as a serial printer, into this 9-pin port. If the device has a 25-pin connector, you need a 25-to-9-pin serial adapter.
	<i>Parallel port:</i> Plug a parallel device, such as a parallel printer or network adapter, into this 25-pin port.
	<i>Docking connector:</i> Connect a docking option to this connector. See “Docking Options” on page 82 for more information.



PS/2 mouse and keyboard port: Connect a PS/2-compatible mouse or external keyboard or keypad to this port. Make sure your computer is turned off when you attach peripherals to the port.

You can use the computer's touchpad and a PS/2 keyboard at the same time. If you attach a PS/2 mouse to the port, the computer's touchpad is disabled.

Connecting the Floppy Drive to the Floppy Connector

Computers ship from the factory with both a floppy drive and a CD-ROM drive included. These systems also ship with a floppy cable.



Turn off your computer before you install or remove devices from the SmartBay or connect or disconnect the floppy cable and drive.

To use the floppy drive and the CD-ROM drive at the same time, install the CD-ROM drive in the SmartBay. Then attach the floppy drive to the external floppy connector. Attach one end of the floppy cable to the floppy drive and the other to the external floppy port on the computer (Figure 11).

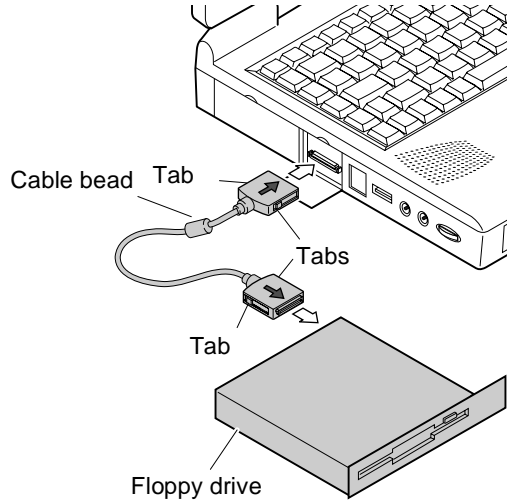

Figure 11. Attaching the Floppy Drive to the Floppy Connector

The floppy cable must be inserted as shown in Figure 11. To insert the cable correctly, make sure that

- The arrows printed on the cable connectors are both facing upward.
- The cable bead is close to the computer, not the floppy drive.



If the cable does not fit easily, do not force it. Make sure you have the correct end of the cable going to the computer and to the floppy drive.

To remove the cable:

1. Press in and hold the tabs on the side of each cable connector.
2. Pull the cable connectors away from the floppy drive and the computer.

Using the SmartBay

Your computer includes the SmartBay™, a peripheral bay that can hold one of the following devices:

- Floppy drive: shipped installed in your computer.
- CD-ROM drive: shipped with some computers.
- Optional secondary hard drive: available as an option for your computer.



Make sure that the computer's power is off before you remove or install a device in the SmartBay.

To remove a device from the SmartBay:

1. Turn the computer's power off.
2. Close the LCD panel, and turn the computer over so that the bottom of the unit faces up.
3. Pull up on the SmartBay latch (Figure 12). The device in the SmartBay pops partially out of the bay.

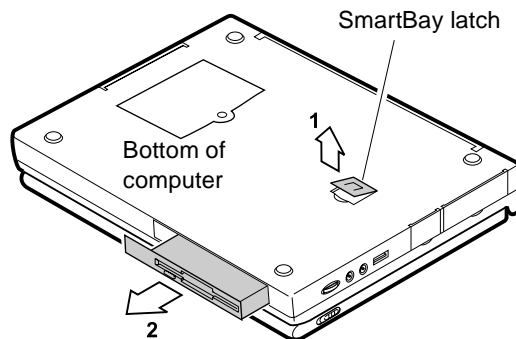

Figure 12. Removing a Device from the SmartBay

4. Pull the device out of the bay.

To install a device in the SmartBay:

1. Turn the computer's power off.
2. Place the device into the bay.
3. Push the device in until it is flush with the chassis.
4. Push down on the SmartBay latch until the latch snaps into place.

Your computer's operating system automatically recognizes the device in the SmartBay and configures your computer accordingly.

Using the Floppy Drive

The computer comes with a removable 1.44-MB, 3.5-inch, high-density floppy drive, which can read, write to, and format the following disks:

- A high-density, 3.5-inch disk, which stores 1.44 MB of data.
- A double-density, 3.5-inch disk, which stores 720 KB of data.



The floppy drive in your portable computer is smaller but more power-efficient than a floppy drive in a desktop computer. To get the best performance from your floppy drive, handle the drive carefully when installing or removing it and use high-quality floppy disks.

The floppy drive fits in your computer's SmartBay and can also be attached by cable to a connector on the outside of the computer. For information on installing the floppy drive, see "Using the SmartBay" on page 25 and see "Connecting the Floppy Drive to the Floppy Connector" on page 23.

To use a floppy disk, insert it into the floppy drive (Figure 13).

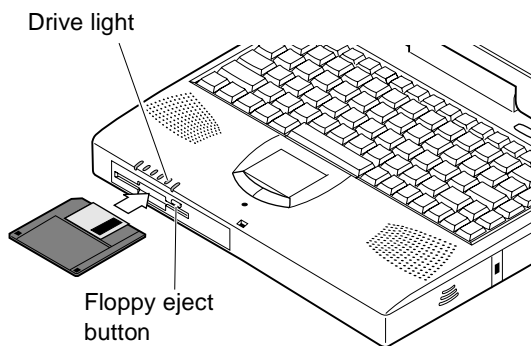

Figure 13. Inserting a Floppy Disk

To remove a floppy disk, press the eject button on the floppy drive.

The drive light on the computer is amber when the computer writes to or reads from a floppy disk. Do not remove a disk when this light is on.

To protect the data on your floppy disks, follow these guidelines:

- Keep disks away from excessive heat, direct sunlight, and liquids.
- Keep magnets and any device that contains a magnet (like the telephone) away from your disks.



Magnetic fields can destroy the information on a disk.

- Do not write directly on a label on your disk; instead, write on a disk label first and attach the label to the disk.
- Make copies of all your important disks.

Using the CD-ROM Drive

Some computers ship from the factory with a CD-ROM drive included. The CD-ROM drive fits into the computer's SmartBay. For information on installing the CD-ROM drive, see "Using the SmartBay" on page 25.

Compact discs are designed so that you can easily insert one into the computer when you need it, and then remove it:

1. Press the button on the CD-ROM drive, and the tray slides out. (Do not lean on the tray; it does not support much weight.)
2. Insert a CD, label side up (or remove a disc, if you have finished using it).
3. Push the tray in gently to close the drive tray (Figure 14).

A light on the drive tray is on when the computer is reading from a CD. Do not remove a disc when this light is on.

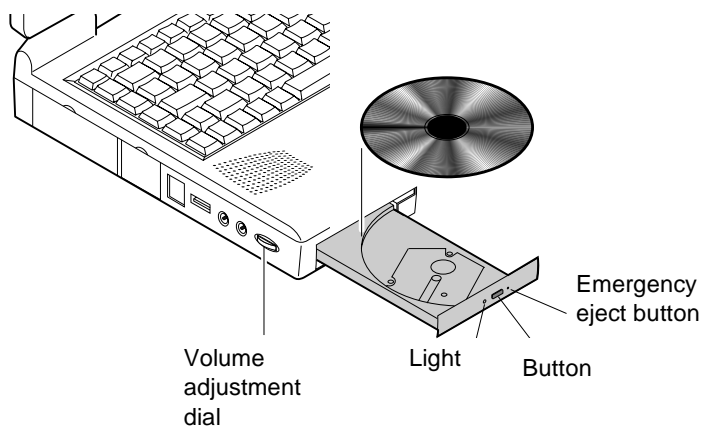

Figure 14. Using the CD-ROM Drive

Install and start a CD-based program as you would a program on a floppy disk. See your operating system documentation for more information on running programs.

The name of the CD-ROM drive is the letter following the letter assigned to your last hard drive. For instance, if you have one hard drive with only one hard drive partition, the hard drive is drive C and the CD-ROM drive is drive D.

If necessary, you can use the emergency eject button to open the CD-ROM drive. To use the emergency eject button, turn the computer's power off and insert a small object, like an unbent paperclip, into the hole to press the button.



Do not place reflective objects in the disc slot because of possible hazardous laser emissions.

The laser beam used in this CD-ROM drive is harmful to the eyes. Do not attempt to disassemble the CD-ROM drive. Refer servicing to your authorized manufacturer's service center.

The on-board audio hardware and software of your computer enable the computer to play audio compact discs. If you wish to do so, you can attach external speakers to the audio-line-out jack.

To play an audio compact disc:

1. Insert a compact disc into your CD-ROM drive:
 - a. Press the button on the CD-ROM drive, and its tray slides out.
 - b. Insert a CD, label side up.
 - c. Push the tray in to close the drive tray. The CD Player button appears on the taskbar.

The disc begins to play.

A light on the drive tray is on when the computer plays a CD. Do not remove a disc when this light is on.

2. To adjust the sound, use the volume adjustment dial on the side of the computer or press the following key combinations:
 - <Fn+F9> decreases volume.
 - <Fn+F10> increases volume.

To remove the CD:

1. Click the CD Player button on the Windows taskbar to open the CD Player window (Figure 15).

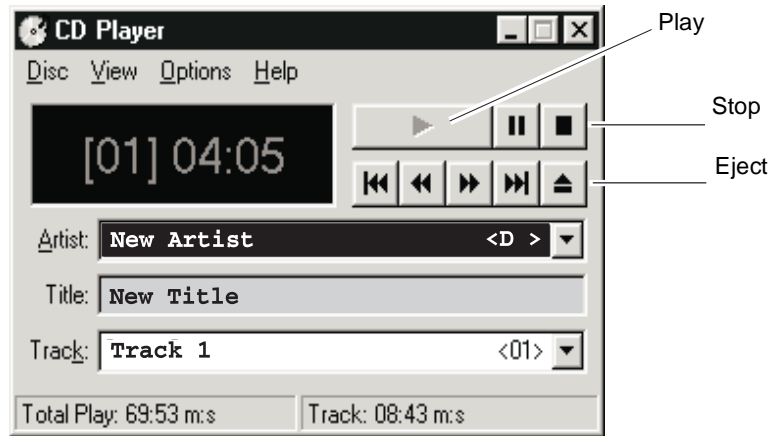

Figure 15. CD Player Window

2. Click the Stop button in the CD Player Window.
3. Click the Eject button on the CD Player window or press the button on your CD-ROM drive. The drive tray opens and you can remove the disc from the CD-ROM drive.

For more information on playing compact discs, see the Help menu in the CD Player window.

Using the Hard Drive

Your computer includes a removable IDE hard drive. The IDE hard drive can store the data and programs your computer uses. The drive plugs into a connector on the system board.

Although the storage capacity of hard drives varies according to model, any hard drive holds much more than a floppy disk does. Also, the computer reads and works with a hard drive more rapidly than with a floppy disk.

Once information is saved on a hard drive, it remains there until it is overwritten. Hard drive heads park automatically when you turn off your computer.



The hard drive that comes with your computer has already been formatted. Do not format the hard drive. Doing so destroys all data contained on the drive. If you need to format a new drive, or want to erase all data on your existing hard drive, refer to the manual for your operating system.

Although Windows 98 can work with FAT-16 or FAT-32 (a 32-bit file allocation table), there are software compatibility issues with FAT-32. Older software that you may have (16-bit software) requires FAT-16 to run.

Removing the Hard Drive



To prevent loss of data and damage to the disk, do not remove the hard drive while the computer's power is on and do not drop or jar the hard drive.

To remove the hard drive from the computer:

1. If you are installing a new hard drive, backup the application and data files on the old hard drive before removing it from the computer.
2. Turn the computer's power off.
3. Close the LCD panel, and turn the computer over so that the bottom of the unit faces up.

4. Remove the screw that holds the hard drive in place (Figure 16).

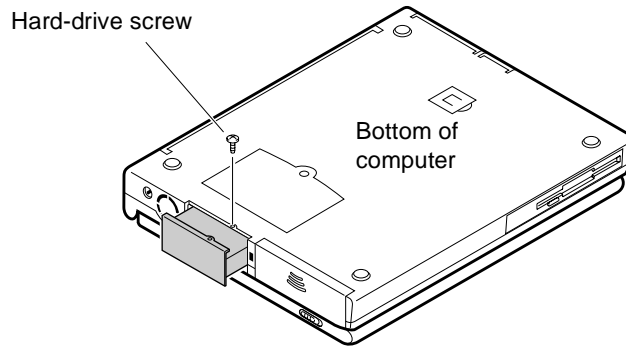

Figure 16. Removing the Hard Drive

5. Pull the hard drive out of the computer.

Installing a Hard Drive

To install a hard drive:

1. Remove the old hard drive from the computer as described in the previous section.
2. Slide the new drive into the hard drive compartment. Make sure the drive is pushed back as far as it will go.
3. Install the screw that holds the hard drive in place.
4. If you intend to use save to disk mode, see “Creating a Save to Disk Partition” on page 62.
5. Format your drive and reinstall your files.

Using the Battery

Your computer uses a smart rechargeable lithium-ion battery pack for power when the AC adapter is not attached to an electrical outlet.

Charging the Battery

Your computer's battery starts charging automatically when you connect the AC adapter to the computer. If the computer is off, the battery charges faster than if the computer's power is on.

Approximate charging times for your battery are

- 3 hours with the computer off
- 6 hours with the computer on

While the battery is charging, the battery charge light on the computer is amber (see Figure 9 on page 19 for the location of the battery charge light). When the battery is fully charged, the light changes to green.

You can also use the optional external battery cradle to charge the battery while it is not in the computer. (See "Battery Cradle" on page 82 for more information.)

When you use a new battery pack for the first time or use a battery after a long period of storage, the initial battery life is shorter than normal. Normal battery life resumes after a few discharge-recharge cycles.

Follow these rules for charging your battery:

- A battery normally discharges power when not used for long periods of time. Be sure to recharge the battery every two months when it is not in use.
- Make it a practice to discharge your battery fully before recharging the battery. This can help extend the life of the battery.
- Do not attempt to charge the battery in temperatures of under 41° F (5° C) or over 95° F (35° C.)



All batteries eventually wear out and lose the ability to hold a charge. You may need to replace your battery pack after a year of average usage.

Safely Using the AC Adapter and Batteries

Follow these guidelines to safely use the AC adapter and batteries:

- Turn your equipment off and unplug the AC adapter if you accidentally:
 - Expose the equipment to liquid.
 - Drop, jar, or damage the computer.
- Use only approved AC adapters and automobile and airline adapters.
- Do not disassemble the battery, heat it above 122° F (50° C), or burn it. The battery used in this computer may cause a fire or chemical burn if mistreated.
- Your computer's rechargeable battery may be considered hazardous waste. If you replace your battery with a new one:
 - Keep the old battery out of the reach of children.
 - Dispose of the old battery promptly.
 - Make sure that you follow all state and local requirements when you dispose of the old battery.

Removing and Installing the Battery

Your computer comes with the battery pack installed. To remove the battery pack:

1. Turn the computer's power off.
2. Close the LCD panel, and turn the computer over so that the bottom of the unit faces up.
3. Slide the battery compartment cover straight up and off the computer (Figure 17).

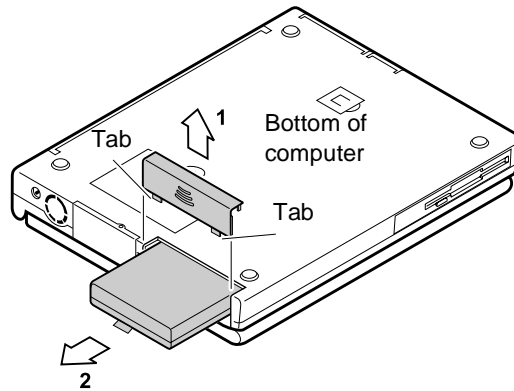

Figure 17. Removing the Battery Pack

4. Grasp the plastic tab on the battery and pull the battery out of the compartment.

To reinstall the battery pack:

1. Turn the computer's power off.
2. Close the LCD panel and turn the computer over so the bottom of the unit faces up.
3. Slide the battery pack into the compartment. Make sure the battery is fully inserted into the compartment.
4. Align the tabs on the battery compartment cover with the slots on the battery compartment.
5. Push the cover straight down until it snaps into place.

Monitoring the Battery Charge

Battery life is affected by factors such as the power-management settings in System Setup, the applications you use, and the brightness and contrast settings of the LCD. Under normal usage, the battery charge lasts approximately 2 hours.



Battery life estimates are subject to variation. The actual life of your battery may be less than the estimates given in the documentation.

You can monitor the charge of the battery pack installed in your computer through the battery gauge.

Using the Battery Gauge

You can display the battery gauge while you are in any program. Press <Fn+F6> to display the battery gauge on the LCD (Figure 18).



Figure 18. Battery Gauge

The gauge has two sections:

- The top section of the gauge shows a picture of a battery to indicate that the computer is operating from the battery.
- The bottom section of the gauge shows you the amount of battery charge remaining.

While the battery gauge is displayed, all keys are disabled. The battery gauge closes in a few seconds.



Because of the characteristics of battery cells, the battery gauge may be inaccurate for 10 minutes after you charge the

battery. Wait until the computer has been operating from the battery for 10 minutes before you check the battery gauge.

Using the Main Battery Lights

There are four battery status lights on the main battery that indicate if the main battery is charging and the amount of battery charge remaining.

To see how much charge remains in the main battery, remove the battery (See “Removing and Installing the Battery” on page 35 for more information.) and press the battery status button. Each light indicates a 25 percent charge. For example, if three lights are on, the battery has a 75 percent charge. The battery status lights automatically turn off two seconds after you release the battery status button.

Using PowerProfiler to Monitor the Battery

PowerProfiler enables you to set power-management options for computers shipped with Windows NT installed. To use PowerProfiler to monitor the battery charge, place the cursor on the battery icon in the right corner of the taskbar. PowerProfiler shows you the amount of battery charge remaining.

The color of the battery icon also indicates approximate battery charge:

- Green: Charge is adequate to power computer.
- Yellow: Charge is low.
- Red: Charge is very low.

You can determine at what battery charge level PowerProfiler shows the low and very low colors. The default setting for the very low level is 20 percent battery charge remaining.

To set battery monitoring options in PowerProfiler:

1. Double-click the PowerProfiler battery icon to open the software.
2. Click the Battery tab.
3. Set options under *Battery Status and Alarm Settings*.

For more information on PowerProfiler, see the Help option in the PowerProfiler software.

Battery Warnings

Your computer gives you the following low-battery warnings (Table 4).

Table 4. Battery Warnings

Warnings	Condition	Action to Take
The computer beeps 5 times (low-pitched beeps). In Windows 98, a battery-low warning appears on screen.	Battery low: The battery charge is about 10 percent. Approximately 5–10 minutes of battery charge is left.	Save your work. Use the AC adapter to power the computer or turn off the computer and install a fully charged battery.
The computer beeps 5 times (high-pitched beeps), with a short time between beeps. After a short time, the computer automatically goes into rest mode.	Battery very low: The battery charge is about 3 percent.	Use the AC adapter to power the computer and charge the battery.

If you cannot run your computer from the battery and the battery will not charge when you attach the AC adapter, the problem may be that

- The battery temperature is over 95° F (35° C) or below 41° F (5° C). If you think the battery temperature is too hot or too cold, turn off the computer, remove the battery, and let the battery reach room temperature. Then try charging the battery again.
- The battery is defective. Replace the battery with a new battery.

Using System Setup

The System Setup program enables you to configure your computer hardware and set security and power-savings options. The settings you choose are stored in battery-maintained memory (CMOS memory) that saves the information even when the computer's power is turned off. When your computer is turned back on, your computer is configured with the values found in this memory.

Run System Setup if you get a message prompting you to run the program. You may also want to run System Setup, particularly the first time you use your computer, to set the time and date, use security or power-management features, or alter the settings of other features.



Your computer's version of System Setup may not include all the fields listed here or may include additional fields. Field names and order of appearance can vary according to the version of the BIOS on your computer.

You can use the configuration listing at the back of this manual to record information specific to your computer. Fill it out as you complete your System Setup configuration. This list helps you describe your computer if you must contact your authorized reseller for service or product information.

Starting System Setup

To start System Setup, turn on your computer and then press <F2> when prompted. The System Setup screen appears.

The top of the System Setup screen has a menu bar with the selections listed in Table 5.

Table 5. System Setup Menus

Menu	Function
Main	Changes the basic system configuration.
Advanced	Configures advanced features on your computer.
Security	Enables security features, including passwords and backup and virus-check reminders.
Power	Configures power-management features.
Boot	Specifies the order of boot devices.
Exit	Specifies how to exit System Setup.

To open a menu, use the left or right arrow keys to select the menu name and then press <Enter>.

Table 6 lists the keys you can use to navigate through System Setup.

Table 6. System Setup Navigation Keys

Navigation Key	Alternate Key	Function
<F1>	<Alt+H>	Displays the General Help window.
<Esc>		Exits the current menu.
<Left Arrow> and <Right Arrow> keys	Keypad arrow keys	Select a different menu.
<Up Arrow> and <Down Arrow> keys	Keypad arrow keys	Move the cursor up and down between fields.

<Tab>		Moves the cursor forward through the cells for a highlighted field. If the field has only one cell, the <Tab> key moves the cursor down to the next field.
<Tab+Shift>		Moves the cursor backward through the cells for a highlighted field. If the field has only one cell, the <Tab+Shift> key combination moves the cursor up to the previous field.
<Home>	<PgUp>	Moves the cursor to the field at the top of the window.
<End>	<PgDn>	Moves the cursor to the field at the bottom of the window.
<F5>	<->	Scrolls backwards through the options for the highlighted field.
<F6>	<+> or <Space>	Scrolls forward through the options for the highlighted field.
<F9>		Sets the parameters for the current menu to their default values.
<F10>		Exits System Setup and saves the changes. -
<Enter>		Executes commands or opens a submenu.

A pointer symbol appearing to the left of a field indicates that you can open a submenu from this field. A submenu contains additional options for a field. To open a submenu, highlight the field and press <Enter>. Use the same keys to enter values and move from field to field within submenus as you use within menus.

When you highlight a field, information about the field appears on the right side of the screen. System Setup also provides a General Help screen that can be opened from any menu by pressing <F1> or <Alt+H>. The General Help screen lists the navigation keys with their corresponding alternates and functions.

When a scroll bar appears to the right of a help window, more information is available than can be displayed in the window. Use the <PgUp> and <PgDn> keys or the <Up Arrow> and <Down Arrow> keys to scroll through the entire help document. Press <Home> to display the first page, or press <End> to go to the last page. To exit the help window, press <Enter> or <Esc>.

If your computer will not boot after you have changed settings in System Setup and exited the program, reboot and press <F2> to reenter System Setup. Once in System Setup, you can try to change the values that caused your computer boot to fail. If the problem persists, press <F9> to load the default values.

Main Menu

When you open System Setup, the Main menu appears. You can make changes to your computer's basic system configuration from this menu. The fields displayed in this menu are described below.

System Time: Sets your computer to the time that you specify, usually the current time. Enter the hour, minute, and second in the format *hh:mm:ss*. Use a 24-hour clock. Use the tab key to move between the hour, minute, and second cells. Use the hyphen key <-> or <Space> bar to decrease or increase the numbers.

System Date: Sets your computer to the date that you specify, usually the current date. Enter the month, day, and year in the format *mm:dd:yyyy*. Use the tab key to move between the month, day, and year cells. Use the hyphen key <-> or <Space> bar to decrease or increase the numbers. This field supports year dates of 2000 and beyond.

Diskette A: Specifies a drive type for floppy drive A. Drive A is the floppy drive that is inserted in the SmartBay of your computer. *Diskette A* options are *Not Installed* and *1.44/1.25 MB 3½* (default).

Primary Master and Secondary Master: Your computer can support two IDE drives. The Main menu contains two IDE adapter fields to configure these drives. *Primary Master* defines the hard drive installed in the computer. *Secondary Master* defines the CD-ROM drive.

To configure a replacement or upgrade hard drive, move the cursor to select the *Primary Master* field in the System Setup Main menu, and then press the <Enter> key. The IDE Adapter submenu appears.

Normally, you can use the *Auto* field in the submenu to automatically set the values for the other fields in the submenu. Manually set the other fields in this submenu only if the drive you have installed in your computer is not recognized by System Setup.

After you make your selections from this submenu, press the <Esc> key to exit back to the Main menu.

You do not need to configure the drive that came with your computer.



Before attempting to configure a hard drive, make sure you have the configuration information supplied by the manufacturer of the hard drive. Incorrect drive settings can cause your computer to malfunction.

Each IDE adapter field calls up a submenu. The following fields are found in the submenu:

Type: Configures the hard drive type. If you know the correct drive type for your hard drive, enter the number (1-39) or choose *CD-ROM* for a CD-ROM drive. All remaining fields in this submenu are then filled with the correct values for the disk type. If you do not have the documentation that came with your upgrade hard drive, try to use the *Auto* option as described above.

To configure a drive that is not one of the 39 standard drive types, specify *User*. Manually enter the number of cylinders, heads, and sectors for your drive. Refer to your drive's user documentation or look on the drive to obtain this information.

If no drive is installed or if you are removing a drive and not replacing it, select *None*.

Cylinders: Configures the number of cylinders for the hard drive. Refer to your drive's user documentation or look on the drive to obtain this information. Before you can make changes to this field, the *Type* field must be set to *User*.

Heads: Configures the number of read/write heads for the hard drive. Refer to your drive's user documentation or look on the drive to determine the correct value to enter for this field. Before you can make changes to this field, the *Type* field must be set to *User*.

Sectors: Configures the number of sectors per track for the hard drive. Refer to your drive's user documentation or look on the drive to determine the correct value to enter for this field. Before you can make changes to this field, the *Type* field must be set to *User*.

Multi-Sector Transfers: Sets the number of sectors per block to the highest number supported by the drive. Configuration options are *Disabled* (default), *2 Sectors*, *4 Sectors*, *8 Sectors*, and *16 Sectors*.

LBA Mode Control: Enables or disables 28-bit addressing of the hard drive, without regard for cylinders, heads, and sectors. Note that enabling this field may decrease the access speed of the hard drive. The default is *Disabled*.

32 Bit I/O: Enables or disables 32-Bit I/O. When *Enabled*, your hard drive can work with applications with 32-bit input and output. If the field is *Disabled* (default), your computer works with 16-bit input and output and has lower performance.

Transfer Mode: Selects the method for transferring data between the hard drive and system memory. Refer to your drive's user documentation to specify the correct option for this field. Options are *Standard*; *Fast PIO 1*; *Fast PIO 2*; *Fast PIO 3*; *Fast PIO 4*, *FPIO 3 / DMA 1* and *FPIO 4 / DMA 2*. The default setting for this field depends on the type of hard drive installed in your computer.

SMART Monitoring: SMART (self-monitoring analysis and reporting technology) software monitors the performance of your computer's IDE hard drive. When the SMART Device Monitoring field is enabled, you receive a warning message if the SMART software detects an impending drive failure. This field is for reference only.

Ultra DMA Mode: Enables the hard drive to use ultra DMA transfer mode to transfer data between the drive and system memory. The default setting is *Disabled*.

System Memory: Displays the amount of conventional memory detected by your computer during startup. This field is for reference only.

Extended Memory: Displays the amount of extended memory detected by your computer during startup. This field is for reference only.

Advanced Menu

Selecting *Advanced* from the menu bar displays the Advanced menu.

Plug & Play O/S: Enables you to set the parameters for peripheral ports. Set this field to *No* if your computer uses an operating system that is not plug and play compliant, such as Windows NT. With an operating system that is not plug and play compliant, you manually change the settings for the COM1, COM2, and LPT ports. The BIOS will recognize the new settings. Windows 98 automatically configures the ports regardless of the setting of this field.

PS/2 Mouse Config: Enables or disables the touchpad mouse or keyboard port. Options are *External* (default), *Dual Mouse* and *Disabled*. If you set this field to

External, the touchpad mouse is disabled when an external mouse is attached. If you set this field to *Disabled* a device attached to the port will not function, but you will free up an IRQ (interrupt request line) for use by another device. If you set this field to *Dual Mouse*, the touchpad mouse is enabled when an external mouse is attached.

USB device: Configures the USB controller. The options for this field are *Enabled* (default) and *Disabled*. When the *USB device* field is set to *Enabled*, the computer's operating system uses the default configuration for the controller. If you select *Disabled*, you free up an IRQ for use by another device.

Screen Expansion: Enables the expansion of the screen during boot. When your computer starts, the screens are in 640x480 resolution during boot and then automatically change to the resolution you have specified in the Windows settings. When this field is enabled, the opening screens are expanded beyond 640x480. The default is *Enabled*.

Display Control: Enable you to set the default display. Options are *LCD*, *CRT* and *Both*. Choose *LCD* to use the built-in display only, *CRT* to use an external monitor only or *BOTH* to have both built-in and external displays used as the default display. If you select *CRT* and no external monitor is attached you will see no display until you attach the external monitor. The default is *Both*.

I/O Device Configuration: Opens the *I/O Device Configuration* submenu if you press <Enter> when this field is highlighted. If you attempt to set two ports to the same settings, the fields will be marked with asterisks.

The submenu contains these fields:

Serial port A: Configures serial port A. The options for this field are *Enabled* (default) and *Disabled*. If you set this field to *Enabled*, you can set the *Base I/O Address* field to *3F8 IRQ4* (default), *2F8 IRQ3*, *3E8 IRQ4*, or *2E8 IRQ3*. When the field is set to *Enabled*, the computer's operating system uses the default configuration or the configuration you choose. If you select *Disabled*, you free up an IRQ for use by another device.

Infrared port: Configures the infrared port. The options for this field are *Enabled* and *Disabled* (default). If you set this field to *Enabled*, you can set the *Base I/O Address* field and the *Mode* field. Settings for the *Base I/O Address* are *3F8 IRQ4*, *2F8 IRQ3* (default), *3E8 IRQ4*, or *2E8 IRQ3*. The mode is fixed to *FIR* (fast infrared). *FIR* enables you to set the *DMA channel* to 3 or 1.

When the *Infrared port* field is set to *Enabled*, the computer's operating system uses the default configuration or the configuration you choose. If you select *Disabled*, you free up an IRQ for use by another device.

Parallel port: Configures the parallel port. The options for this field are *Enabled* (default) and *Disabled*. If you set this field to *Enabled*, you can set the *Mode* field and the *Base I/O Address* field. Settings for the Base I/O Address field are *378 IRQ7* (default), *378 IRQ5*, *278 IRQ7* and *278 IRQ5*. Settings for the *Mode* are *Output only*, *Bi-directional*, *EPP* (enhanced parallel port), and *ECP* (extended capabilities port). Selecting the ECP setting enables you to set the DMA Channel to 1, 2, or 3.

When the *Parallel port* field is set to *Enabled*, the computer's operating system uses the default configuration or the configuration you choose. If you select *Disabled*, you free up an IRQ for use by another device.

Floppy disk controller: Configures the floppy disk controller. The options for this field are *Enabled* (default), *Auto*, and *Disabled*. When the *Floppy disk controller* field is set to *Enabled*, the computer's operating system uses the default configuration for the controller. Selecting *Auto* enables the operating system or the BIOS to configure the port.

Memory Cache: Opens a submenu that enables or disables external cache memory. Cache memory improves system performance by keeping frequently used computer instructions in memory with a faster access time than DRAM.

The submenu fields are:

Memory Cache: *Enables* (default) or *disables* your computer's (level 2) cache memory. Normally, do not disable the cache memory unless a program's documentation specifies that the computer cache memory must be disabled.

Cache Memory Region: *Enables* or *disables* (default) caching of shadowed option ROMs in the following regions: CC00-CFFF, D000-D3FF, D400-D7FF and D800-DBFF

Local Bus IDE adapter: Enables the integrated IDE local bus adapters. Options are *Enabled* (default) and *Disabled*. The Enabled option enables both the primary IDE adapter (for the hard drive) and the secondary IDE adapter (for the CD-ROM drive) on the computer.

Large Disk Access Mode: Enables your computer's operating system to work with drives larger than 540 MB. Choose *DOS* (default) for Microsoft operating systems. Choose *Other* for any other operating systems.

Security Menu

Selecting *Security* from the menu bar displays the Security menu. Your computer's advanced security system allows you to set two different passwords to prevent unauthorized access to system resources, data, and System Setup. From the Security menu, you can enable a boot password, disk access, a system backup reminder, and a virus check reminder.

Security fields marked with an asterisk can only be changed if you start System Setup with a system supervisor password or if no passwords are in effect. You cannot access these fields with a user password.

Set User Password: Enables you to set a user password to control access to the system at boot. See "Creating a Password" on page 54 for instructions on setting a password. The user password allows restricted access to the System Setup Security menu; the user has access only to changing his own password and to enabling or disabling *Password on boot*. A supervisor password must be set before a user password can be set

Set Supervisor Password: * Enables you to set the supervisor password to control access to the System Setup utility. See "Creating a Password" on page 54 for instructions on setting a password.

Password on boot: Determines whether the computer prompts for a password when starting up. The options are *Enabled* and *Disabled*. A supervisor password must be set before you can enable this option.

Fixed disk boot sector: * Enables you to write-protect the hard drive boot sector to protect against viruses and alterations. Only a user with the supervisor password can access this field. The options for this field are *Normal* (default) and *Write Protect*.

Diskette access: * Enables you to restrict the use of floppy drives. When set to *Supervisor* (default), the use of floppy drives is restricted to a user with the supervisor password. A supervisor password must be enabled before the *Supervisor* option can take effect. When set to *User*, users with either type of password have access to floppy drives. If the field is set to *Supervisor* and a user password is enabled, the user must enter the supervisor password in order to boot from the floppy drive.

Virus check reminder: * Enables the computer to prompt you to scan the computer for viruses. The prompt appears each time you start your computer or reboot until you respond with *Y* (yes). The options for this field are:

- *Daily*: Every day when you start your computer for the first time, the prompt appears.
- *Weekly*: When you start your computer for the first time each week (after Sunday), the prompt appears.
- *Monthly*: When you start your computer for the first time each month, the prompt appears.
- *Disabled*: The prompt never appears. This is the default setting.

For a *Daily*, *Weekly*, or *Monthly* prompt to be accurate, *System Date* in the Main menu must be set to the current date.

System backup reminder:* Enables the computer to prompt you to backup your files. The prompt appears each time you start your computer or reboot until you respond with *Y* (yes). The options for this field are

- *Daily*: Every day when you start your computer for the first time, the prompt appears.
- *Weekly*: When you start your computer for the first time each week (after Sunday), the prompt appears.
- *Monthly*: When you start your computer for the first time each month, the system backup prompt appears.
- *Disabled*: The prompt never appears. This is the default setting.

For a *Daily*, *Weekly*, or *Monthly* prompt to be accurate, *System Date* in the Main menu must be set to the current date.

Power Menu

The Power menu of System Setup allows you to enable and adjust your computer's sophisticated power-saving features. Enabling these features extends the life of the battery.

If your computer shipped with Windows 98 installed, Windows 98 Power Management works with the settings in the Power Management option on the Control Panel.

Power Savings: Sets the Power Management Mode. Choosing modes changes the system power management settings. The options are *Maximum Power Savings* (default), *Maximum Performance*, *Disabled* and *Customized*. *Maximum Power Savings* conserves the greatest amount of system power while *Maximum Performance*

conserves power but allows greatest system performance. To alter these settings, choose *Customized* and to turn off power management choose *Disabled*.

Battery Power Saving Mode: Enables and disables turbo mode. The options are *Turbo* (default) and *Non-Turbo*. If you set this field to *Turbo*, the microprocessor and hard drive run at full speed, unless affected by other power-savings settings. If you set this field to *Non-Turbo*, the microprocessor and the hard drive run at slow speed, unless there is user input or device activity.

Standby Timeout: Sets the period of computer inactivity (no user input or device activity) that must pass before your computer automatically goes into standby mode. In standby mode some devices are turned off (including the LCD screen) and the microprocessor slows down. You can disable this option by selecting *Off*, or you can specify a *Standby Timeout* delay time of from 1 to 16 minutes. The default is *1 Minute*.

Suspend Mode: Specifies the type of suspend mode your computer enters:

- *Suspend* (default): Saves power by turning off the microprocessor and DMA clocks, video, and all controllable peripheral devices. Some power is still used when your system is in this mode. This suspend mode is also known as suspend to RAM.
- *Save To Disk*: Provides the greatest power-saving capabilities by essentially turning off your computer. In the save to disk mode, all system logic (except for your computer wakeup circuitry and battery charger) is turned off. During save to disk mode, the DRAM and video memory are saved to the hard drive and are restored when your computer resumes from suspend.

When the computer enters save to disk mode, it will not resume normal operation at a specified time no matter how the *Resume On Time* field is set.

Auto Suspend Timeout: Sets the period of computer inactivity (no user input or device activity) that must pass before your computer enters suspend mode. You can disable this option by selecting *Off*, or you can specify a *Standby Timeout* delay time of from 5 to 60 minutes. The default setting is *5 min*.

Resume On Modem Ring: Enables the computer to resume operation from suspend mode in the event of modem communication. The computer will resume only if the *Suspend Mode* field is set to *Power On Suspend*, not *Save To Disk*. The default setting is *Off*.

Resume On Time: Enables the computer to resume operation from suspend mode at a scheduled time. The computer will resume only if the *Suspend Mode* field is set to

Power On Suspend, not *Save To Disk*. If you set this field to *On*, you must set the *Resume Time* field as well. The default setting is *Off*.

Resume Time: Specifies the time for your computer to automatically resume from suspend mode. Enter two-digit numbers to indicate the hour, minutes, and seconds in the format *hh:mm:ss*. Use a 24-hour clock. Use the tab key to move between the hour, minute, and second cells. Use the hyphen key <-> or <Space> bar to decrease or increase the numbers.

You must set this option if you enable *Resume On Time*.

Boot Menu

The Boot menu enables you to select a boot device and set boot options.

QuietBoot Mode: Enables the MANUFACTURER'S logo screen during POST. The options are *Enabled* (default) and *Disabled*. To view the POST screen during boot choose *Disabled*.

QuickBoot Mode: Enables certain diagnostics to be skipped during POST and the system boots faster. The options are *Enabled* (default) and *Disabled*.

Floppy check: Enables a check of the floppy drive during the tests performed by the computer at startup. When this field is enabled, a complete POST is performed at startup. The options are *Enabled* (default) and *Disabled*.

Summary screen: Displays the system configuration when the computer starts. The options are *Enabled* (default) and *Disabled*.

Boot Device Priority: Enables you to select the order in which the computer attempts to boot from different devices. The field has three options: *ATAPI CD-ROM Drive*, *Diskette Drive* and *Hard Drive*.

To choose a device as the first, second, or third boot device:

1. Press <Enter> at the *Boot Device Priority* field
2. Highlight the option with the <Up Arrow> or <Down Arrow> key.
3. Press the <Space> bar or <-> (hyphen key) until the option moves up or down in the list of options and the number *1*, *2*, or *3* appears beside the option.
4. Press <Esc> to return to the Boot menu.

The default setting is *1.ATAPI CD-ROM Drive*, *2. Diskette Drive* and *3.Hard Drive*. With these default settings, your computer first attempts to boot from a bootable CD-ROM. If a bootable CD-ROM is not inserted in the CD-ROM drive, the computer will attempt to boot from the floppy drive and then the hard drive.

Exit Menu

Select *Exit* from the menu bar to display the Exit menu.



Pressing <Esc> does not exit this menu. You must select one of the options from this menu or a menu bar item to exit this menu.

Exit Saving Changes: Enables you to exit System Setup and saves your changes. When you select this item and press <Enter>, a message appears asking you if you want to save your changes and exit System Setup. Choose *Yes* and press <Enter> to save your changes and exit. Choose *No* and press <Enter> to remain in System Setup.

Exit Discarding Changes: Enables you to exit System Setup without saving your changes. When you select this item and press <Enter> a message appears asking you if you want to save changes before exiting. Choose *No* and press <Enter> to exit without saving changes. Choose *Yes* and press <Enter> to save changes and exit.

Load Setup Defaults: Loads the default values for all System Setup parameters. When you select this option and press <Enter>, a message appears asking if you want to load the default configuration. Choose *Yes* and press <Enter> to load default settings and remain in System Setup. Choose *No* and press <Enter> to retain your changes and remain in System Setup.

Discard Changes: Enables you to discard the selections you have made and restore the values you previously saved. When you select this option and press <Enter>, a message appears asking if you want to load the previous configuration. Choose *Yes* and press <Enter> to load the previous settings and remain in System Setup. Choose *No* and press <Enter> to retain your changes and remain in System Setup.

Save Changes: Saves your selections without exiting System Setup. When you select this option and press <Enter>, a message appears asking if you want to save configuration changes. Choose *Yes* and press <Enter> to save changes and remain in

System Setup. Choose *No* and press <Enter> to discard changes and remain in System Setup.

Battery Calibration: Enables you to discharge the system battery completely for a more accurate battery level detection. This option only works with the SMART battery.

Using System Security

This section describes the security options provided with your computer.

System Passwords

The computer provides two levels of password security: administrative-level (supervisor) and user-level (user). Either password prevents unauthorized access to the computer. The supervisor password enables full access to all System Setup fields. The user password enables full access to only the *Set User Password* and *Password on boot* security fields and read access to all other System Setup fields. (See “Security Menu” on page 48 for a complete list of System Setup security fields.)

If multiple users have access to the computer (such as in a network environment), a supervisor password can prevent unauthorized access to certain security options.

Choose the type of password security that is appropriate for your work. If you want to set a user password, you must set a supervisor password first.

Creating a Password

To create a password:

1. At startup, press <F2> to open System Setup.
2. Use the <Right Arrow> key to select the Security menu.
3. Use the <Down Arrow> key to select *Set Supervisor Password* or *Set User Password*.
4. Press <Enter>. The Set Password dialog box appears.
5. Type a password of up to seven characters. You can enter letters or numbers, but you cannot use the function keys, such as <Shift>. Your computer does not distinguish between capitalized and lowercase letters in your password. As you type the password, the cursor moves but your password does not appear on the screen.

6. Press <Enter> after you have typed your password. The computer prompts you to reenter your password for verification.
7. Type your password again and press <Enter>. A message appears telling you that the changes have been saved. Press <Enter> again to return to the Security menu.
8. Press <Esc> to go to the Exit menu.
9. Select *Exit Saving Changes*, press <Enter>, and press <Enter> again to restart the computer.

Deleting a Password

To delete the password:

1. At startup, press <F2> to open System Setup.
2. Type your password when prompted and press <Enter>.
3. Use the <Right Arrow> key to select the Security menu.
4. Use the <Down Arrow> key to select *Set Supervisor Password* or *Set User Password*.
5. Press <Enter>. The computer prompts you to enter the current password.
6. Press <Enter>. The computer prompts you to enter a password. Do not type anything.
7. Press <Enter>. The computer prompts you to re-enter the password. Do not type anything.
8. Press <Enter>. A message appears telling you that the changes have been saved. Press <Enter> again to return to the Security menu.
9. Press <Esc> to go to the Exit menu.
10. Select *Exit Saving Changes*, press <Enter>, and press <Enter> again to restart the computer.

Requiring a Boot Password

After you create a supervisor or user password, you can enable the computer to prompt for a password each time it starts.

To enable the prompt, select the option *Enabled* in the *Password on boot* field in System Setup. For more information about the *Password on boot* field, see “Security Menu” on page 48.

Locking the Hard Drive Boot Sector

If you have an supervisor password, you can lock the hard drive boot sector to protect against viruses or alterations.

To lock the hard drive boot sector, select the option *Write protect* in the *Fixed disk boot sector* field in System Setup. For more information about the *Fixed disk boot sector* field, see “Security Menu” on page 48.

Locking the Floppy Drive

If you have an supervisor password, you can lock the floppy drive so that a user with only a user password cannot load personal software, which may introduce a virus into the computer.

To enable the floppy lock, select the option *Supervisor* in the *Lock Floppy* field in System Setup. For more information about the *Lock Floppy* field, see “Security Menu” on page 48.

Locking the Keyboard

The keyboard lock enables you to protect your system when you walk away from it for a time. To use the keyboard lock, you must first enable a password through System Setup. (See “Creating a Password” on page 54 for instructions. To lock your keyboard, press <Fn+F7>. To unlock your keyboard, type your password and press <Enter>

Using Power Management Options

Your computer includes power-management options that can help the battery charge last longer and extend the life of the battery, LCD panel, and other components. Power-management options slow down or shut off system components when the components are not being used.

Power management slows down system performance. Your computer runs fastest with the AC adapter attached, when no power management is in effect.

If your computer shipped with Windows 98 installed, Windows 98 Power Management works with the settings in the Power Management option on the Control Panel. If your computer uses DOS or Windows 95, Power Management works with the settings in System Setup

If your computer shipped from the factory with Windows NT installed, PowerProfiler power management software was included.



Some applications may require the computer to run at full speed to operate correctly. If you experience any problems with an application, try disabling power management.

When running the computer from the battery, you can press <Fn+F3> to set the computer to full speed.

Non-Turbo Mode

In non-turbo (or idle) mode, the microprocessor and hard drive run at slow speed unless there is user input or device activity. To enable non-turbo mode, set the *Battery Power Saving Mode* field in System Setup to *Non-Turbo*.

When you touch the touchpad or press a key or when there is device activity, the computer returns to full-speed (turbo) operation.

Standby Mode

The *Standby Timeout* field in System Setup enables you to specify the time period that the computer can remain idle (no user input or disk activity) before the computer enters standby mode. You can disable this option by selecting *Off*, or you can specify a *Standby Timeout* delay time of from 1 to 16 minutes.

In standby mode, the system and video memory and the video controller slow down. The LCD backlight, hard drive, floppy drive, PC Card controller, and some other devices turn off to save energy. DPMS (a form of monitor power management) to an external monitor is invoked.

To resume from standby, touch the touchpad. Do not press any keys on your keyboard.



If you press a key to resume from standby, your computer will recognize the function of the key you pressed and perform that function. For example, if you press <N> and a document is open, an “n” is typed into your document.

If you enable both standby and suspend modes, your computer enters standby when the delay time you chose for standby has elapsed, and then enters suspend mode when the delay time you chose for suspend mode has elapsed.

Suspend Mode

The *Suspend Timeout* field in System Setup enables you to specify the time period the computer can remain idle (no user input or device activity) before the computer enters suspend mode. You can disable this option by selecting *Off*, or you can specify a *Suspend Timeout* delay time of from 5 to 60 minutes.

The *Suspend Mode* field in System Setup defines what type of suspend mode your computer enters:

- *Power On Suspend*: This mode saves power by turning off the microprocessor and DMA clocks, video, and all controllable peripheral devices. The computer still uses some power while in this mode. If you leave your computer in power on suspend for several days without the AC adapter attached, the computer's battery will discharge.

- *Save To Disk*: This mode provides the greatest power-saving capabilities by essentially turning off your computer. In this mode, all system logic (except for your computer wakeup circuitry and battery charger) is turned off. During save to disk mode, the DRAM and video memory are saved to the hard drive and are restored when your computer resumes operation.

You can press <Fn+F11> to manually place your computer into suspend mode.



When you use the <Fn+F11> key combination, your computer may postpone entering suspend mode during a critical operation, such as reading from or writing to the hard drive.

To resume to full-power mode, press the power button.

Once all devices return to full-power mode, all active software applications and system states are restored to exactly how they were before your computer entered suspend mode.

When your computer enters or resumes from save to disk mode, screens appear indicating system status. These status screens do not appear when the computer enters or resumes from power on suspend.

Suspend Mode Precautions

Observe the following precautions when using suspend mode:

- Save all open files before you press <Fn+F11> to manually place your computer into suspend mode.
- If you purchased a new hard drive, make sure that you create a save to disk partition equal to the amount of system memory plus 2 MB before you enable save to disk mode. See “Creating a Save to Disk Partition” on page 62 for more information.
- Do not try to resume to full-power mode using battery power if the battery charge is low. If the battery charge is too low, the system may not be able to resume fully. Plug in the AC adapter if your computer cannot resume normal operation because of a low battery charge.



When your computer is in power on suspend or save to disk mode, do not connect or remove any devices (including PC Cards or memory modules) because you may damage the computer or resume to full power may fail. If a floppy disk is in the floppy drive, do not remove it or switch it with another disk.

However, you can plug in the AC adapter if the resume to full power fails because of a low battery charge.

When the computer is in save to disk mode, you can remove and replace the battery.

Using PowerProfiler

PowerProfiler enables you to set power-management options for computers shipped with Windows NT installed. To open the PowerProfiler window, double-click the battery icon on the right corner of the Windows taskbar. If you click the icon with the right mouse button, a menu appears with an option to put the computer in suspend (suspend mode).

Click the Standard tab in PowerProfiler to set timeouts for the LCD and the hard drive. You can also set power management to be enabled *Always*, *Battery Only*, or *Never*. The Advanced screen in PowerProfiler enables resume from suspend options, and the Battery screen enables options to conserve battery life.

Keep the following in mind when using PowerProfiler:

- If you disable power management in PowerProfiler, the setting overrides any power-management settings in System Setup.
- If you enable LCD and hard drive timeouts in PowerProfiler and the standby timeout in System Setup, the LCD and hard drive turn off when the shortest timeout period in either program passes.
- If you disable the *Resume on Time* field in System Setup, the same field in PowerProfiler is also automatically disabled. An easy way to work with these two fields is to set the resume time to 0 in System Setup and set the actual resume time that you desire in PowerProfiler.
- To enable your computer to resume from suspend on a modem ring, enable the *Resume on Modem* field in System Setup and the same field in PowerProfiler.



PowerProfiler maintains the accuracy of the system clock when the computer resumes from suspend mode. If PowerProfiler is closed or removed from your hard drive, your system clock may not be accurate when your computer resumes from suspend mode.

For more information on PowerProfiler, see the Help option in the PowerProfiler software.

Creating a Save to Disk Partition

The hard drive shipped in your computer has a save to disk partition in which data from system and video memory is stored during save to disk mode. The partition is the maximum size needed for your computer and supports system memory of 128 MB. You can add memory modules to your computer without changing the size of the partition.

If you add a new hard drive to your computer, you can create a save to disk partition on the new hard drive using the Phoenix PHDISK utility, provided with your computer.



If you do not intend to use save to disk mode, you do not need to create a save to disk partition.

If you want to put programs or files from your current hard drive onto the new hard drive, do the following before creating a save to disk partition on the new drive:

- Back up data files on your old hard drive.
 - For Windows 98, you can use the Microsoft Backup Utility. To open the Microsoft Backup utility, click the Start button on the Windows 98 taskbar, select *Programs*, select *Accessories*, select *System Tools*, and click *Backup*.
 - For Windows NT, you can use the Windows NT Backup Utility to back up data files. The Backup Utility requires a tape drive. You can also back up files to a network.
- Create copies of any software that is not included on your restore CD. You can use the Disk Utility to create these copies. To open the Disk Utility, click the Start button on the Windows taskbar, select *Programs*, and click *Disk Utility*.

To create the save to disk partition on the new drive:



To create a save to disk partition, you need a DOS bootable disk that contains FDISK and the Format command. This disk is not provided with the Windows NT Operating System.

1. Create a Phoenix PHDISK utility disk using the Disk Utility. To open the Disk Utility, click the Start button on the Windows taskbar, select *Programs*, and click *Disk Utility*.

2. Turn off the computer, remove your old hard drive, and insert the new one into your computer. (See “Using the Hard Drive” on page 32 for instructions.)
3. If you have a CD-ROM drive, install the CD-ROM drive in the SmartBay and attach the floppy drive to the external floppy connector. (See “Using the SmartBay” on page 25 and see “Connecting the Floppy Drive to the Floppy Connector” on page 23 for instructions.)
4. Under the Boot menu in System Setup, set *Diskette Drive* as the first boot device and *CD-ROM Drive* as the second. (see “Using System Setup” for information on setting options.)
5. Insert the bootable disk into the floppy drive and start your computer.
6. After your system boots, remove the startup disk from the floppy drive and insert the PHDISK disk.
7. At the A: prompt, type:

```
phdisk /c 135168 /p
```

and then press <Enter>.

PHDISK automatically creates a save to disk partition of the maximum size for your computer.

When the save to disk partition has been created, the following message appears:

```
Save to disk partition created successfully
```

8. Remove the PHDISK floppy disk from the floppy drive and insert the startup disk.
9. Use the FDISK utility in DOS to create user partitions on your drive, and then restart your computer. Be careful not to delete the non-DOS partition that you just created with PHDISK.
10. Use the Format command to format the new partitions, and then restart your computer.
11. Remove the startup disk and turn off your computer.
12. Do one of the following to reinstall your applications:
 - If you have a CD-ROM drive, insert your restore CD in the CD-ROM drive and start the computer.

Follow the directions included with the restore CD to restore your operating system and factory-installed programs.

- If you do not have a CD-ROM drive, restore your applications from the backup floppy disks you created.

13. Reinstall any data files that you backed up.



If you do not intend to use the save to disk mode, you can delete the save to disk partition on a hard drive using PHDISK /delete. Then you can repartition and reformat the save to disk partition for some other application. Back up your hard drive before deleting the partition if you feel unsure of how to do this.

Changing the Video Configuration

Your computer includes a TFT screen or active-matrix. The capabilities of the screen plus the video drivers installed on the computer determine the quality of the image your LCD can display.

The following sections describe the display capabilities of your computer.

Resolution and Color Depth

The resolution of the LCD is the sharpness of the image it can display. Resolution is measured by the number of pixels (individual dots) displayed on the entire screen. In general, the more pixels the LCD can display, the better the image.

Your LCD screen is either SVGA or XGA:

- The maximum display for the SVGA LCD screen is 800x600, about 480,000 pixels.
- The maximum display for the XGA LCD screen is 1024x768, about 800,000 pixels.

The number of colors the LCD can display is measured by how many bits the LCD uses to represent each pixel:

- 8-bit color can support 256 different colors.
- 16-bit color can support 64 K (65,536) colors.
- 24-bit color can support 16 M (16.8 million) colors.
- 32-bit color can support 16 M (16.8 million) colors.

24-bit color uses the RGB color model.

32-bit color uses the CMYK color model which gives better printed color matching.

Table 7 lists the basic video mode capabilities and maximum colors supported by your computer.

Table 7. Video Driver Capabilities

Software Drivers	Resolution Supported	Number of Colors
Windows 98	512x384, 640x350, 640x400, 640x480, 720x480, 800x600, 864x480, 1024x600, 1024x768, 1152x864, 1280x1024, 1600x1200	256
	512x384, 640x350, 640x400, 640x480, 720x480, 800x600, 864x480, 1024x600, 1024x768, 1152x864, 1280x1024, 1600x1200	65,536
	512x384, 640x350, 640x400, 640x480, 720x480, 800x600, 864x480, 1024x600, 1024x768, 1152x864, 1280x1024	16.8 million
	512x384, 640x350, 640x400, 640x480, 720x480, 800x600, 864x480, 1024x600, 1024x768, 1152x864	16.8 million
Windows NT® 4.0	640x480, 800x600, 1024x768, 1152x864, 1280x1024, 1600x1200	256
	640x480, 800x600, 1024x768, 1152x864, 1280x1024, 1600x1200	65,536
	640x480, 800x600, 1024x768, 1152x864, 1280x1024	16.8 million
	640x480, 800x600, 1024x768, 1152x864	16.8 million

All these video modes can be displayed on an external monitor. However, if you disconnect an external monitor that was attached to your computer and then start the computer, the LCD may revert to a different resolution than the one you chose for the external monitor.

Configuring Display Features

The following sections describe how to configure the display settings on your computer.

Selecting a Monitor Type

When you attach an external monitor to your computer, Windows 98 automatically selects display settings for it (this feature is not available in Windows NT). If you wish, you can adjust the display settings by selecting a monitor type:

1. Click the Start button on the Windows 98 taskbar.
2. Select *Settings*.
3. Click *Control Panel*. The Control Panel window appears.
4. Double-click the Display icon. The Display Properties window appears.
5. Click the Settings tab. The Settings screen appears.
6. Click the Advanced Properties button. The Advanced Properties screen appears.
7. Click the Monitor tab.
8. Click the Change button. The *Update Device Driver Wizard* screen appears.
9. Click the Next button.
10. Select the *Display a list of all the drivers in a specific location* radio button and click the Next button.
11. Select the *Show all hardware* radio button.
12. Select a manufacturer and model setting that matches your external monitor. Your computer has an intelligent video chip set that automatically matches your LCD panel resolution and frequency when an external monitor is not present.
13. Click the Next button.
14. The *Update Device Driver Wizard* screen appears showing the driver location of the device you have selected. Click the Next button.
15. Click the Finish button. Follow any prompts that appear on the screen.

Changing Color Depth and Resolution

To change the color depth and resolution of your LCD or external monitor:

1. Click the Start button on the Windows taskbar.
2. Select *Settings*.

3. Click *Control Panel*. The Control Panel window appears.
4. Double-click the Display icon. The Display Properties window appears.
5. Click the Settings tab. The Settings screen appears.
6. To change the color depth, click the arrow next to *Color palette* and select the color depth you want.
7. To change the resolution, click and drag the knob under the *Screen area* until you select the resolution you want.
8. Click the OK button.
9. Follow the prompts that appear on the screen.

Working with PC Cards

By installing PC Cards, you can add functions to your portable computer similar to those found on add-in boards for desktop computers. Available PC Cards include:

- Input/output, such as modem, network, pager, video capture, and SCSI cards.
- Storage, such as hard drive cards.
- Combo cards, such as a combination modem and network card.

Your computer includes the following PC Card support:

- Two PC-Card slots: You can install Type I, II, or III cards in the slots. Type III cards are thicker than Types I and II. If you install a Type III card in the bottom slot, you cannot install a card in the top slot.
- CardBus hardware and software: CardBus enables the computer to use 32-bit PC Cards. Windows 98 supports 32-bit and 16-bit PC Cards. The SystemSoft® CardWizard™ for Windows NT program, provided with systems that ship from the factory with Windows NT installed, also supports both 16-bit and 32-bit cards.
- Zoomed video: The bottom PC Card slot and the video chip on your computer support zoomed video. When you install a zoom video PC Card in the bottom slot, data can be transferred directly from the PC Card to video and audio systems without going through the microprocessor. Video conferencing and real-time multimedia devices, such as video cameras, are supported by zoom video.



To use the CardBus and zoomed video technology, install the CardBus and zoomed video drivers provided with your PC Card. If no drivers were supplied with your card, contact the PC Card manufacturer. ATA and modem PC Cards do not require extra drivers.

The following sections tell you how to work with PC Cards.

Maintaining PC Cards

To maintain your PC Cards, follow these guidelines:

- Keep cards away from excessive heat, direct sunlight, and liquids.
- Do not drop, bend, flex, or crush cards when handling.
- Keep dust, magnets, and static electricity away from PC Cards.
- When a card is not in use, carry it in its protective carrying case.
- Some PC Cards include cables that extend from the back of the cards. Be careful not to bend or put excessive strain on these cables.

Using PC Cards

You can install PC Cards while the computer is on.

To insert a PC Card into a slot:

1. Open the slot door.
2. Align the card with a slot and insert the card into the slot until it locks in place (Figure 19).

The eject button for the card slot flips outward when you install a card. If you close the PC Card compartment door, the button flips inward. You need to flip the button outward and then push the button to eject the card.

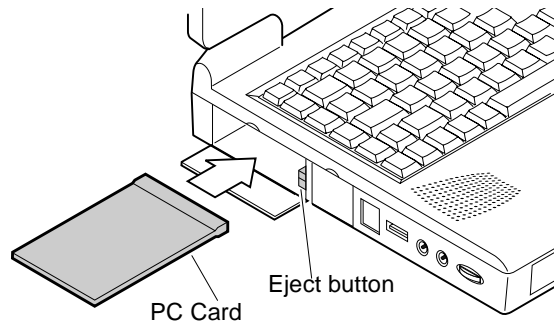

Figure 19. Inserting a PC Card

Windows 98

Windows 98 automatically assigns computer resources (such as communication ports and memory addresses) to a PC Card installed in your computer. For further information on configuring a PC Card in Windows 98, see the index entry *PC card* in the Windows Help. Windows 98 also handles power management for PC Cards.

To remove a PC Card from your computer:



Use the following procedures to remove PC Cards, or you may lose data that is being stored to a card.

1. Click the PC Card icon on the taskbar.
2. Click *Stop* for the card you want to remove. A message appears telling you it is OK to remove the card.
3. Push the card eject button on the side of the PC Card slot.
4. Pull the card out of the PC Card slot.

Windows NT

Systemsoft Card Wizard is shipped with notebook computers that use Windows NT as the operating system. When you install a PC Card, CardWizard attempts to configure it automatically. If Card Wizard successfully assigns system resources to your card, the computer beeps twice.

If CardWizard cannot automatically configure your PC Card, the computer beeps once and a message appears telling you that the card has not been configured. Click the Wizard button on the CardWizard window. CardWizard then analyzes why the card was not configured and fixes the problem or gives you information to help fix the problem.

CardWizard works with the PowerProfiler program to manage PC Cards when the computer enters or resumes from suspend mode. CardWizard gives you instructions to prevent loss of data before the computer enters suspend mode or may stop the computer from entering suspend mode. ATA and modem cards can enter suspend mode.

Follow these guidelines when using PC Cards with CardWizard:

- LAN (local-area network) cards can be inserted while the computer is on but should be removed only when the system is turned off.
- SCSI cards should be inserted at startup to enable Windows NT to find the device attached to the SCSI card. SCSI cards can be removed when the computer is turned off. If you suspend your computer without the SCSI card installed, a message may appear telling you that a service did not start. You can ignore this message.
- Modem and ATA cards can be inserted and removed while the computer is on.



Before you remove a modem or ATA card from your computer, stop the card through the CardWizard program or you may lose data.

To stop and remove a PC Card from your computer:

1. In the SystemSoft CardWizard screen, click with the right mouse button on the name of the card you want to remove.
2. Click Stop in the Actions menu. A red stop sign appears on the main screen when the card is stopped.
3. Click OK.
4. Push the card eject button on the side of the PC Card slot.
5. Pull the card out of the slot compartment.

For more information on using the CardWizard program, see the CardWizard Help.

Troubleshooting

Operating Problems

This section tells you what to do if you have problems running your computer. If any problem persists after you take corrective action, contact your reseller for assistance.

The computer does nothing when you turn it on.

Has the battery run down? Connect the AC adapter or auto/airline adapter to get power and recharge the battery. Try turning on the computer again.

The computer is not behaving as expected.

Operating your computer at high speed with the cache enabled may cause system instability and incompatibility with some operating systems. If your computer is not behaving as expected and no error messages appear, disable the *External Cache* setting in the *Memory Cache* field of System Setup.

Nothing appears on the LCD panel when you turn on the computer.

Adjust the brightness on the LCD. Are you using an external monitor? If so, press <Fn+F5> to return to the LCD panel.

Nothing appears on the external monitor when you switch the display to it.

Is the monitor properly connected to the computer? Is the monitor's power cord connected to an AC wall outlet? Check the brightness and contrast controls on the monitor. Does the program appear on the LCD panel instead of the external monitor? If so, press <Fn+F5> to switch to the monitor. Try turning the monitor off and on again.

The external monitor displays flashes or waves.

Check the cables between the monitor and the computer. Are they properly installed?

Some of the letter keys type numbers instead of the indicated letters.

Is the Num Lock light on? If so, the numeric keypad on the keyboard is active. To return the keypad keys to typing letters, press <Num Lock>.

Battery power seems to run out faster than expected.

If you are running the computer from the battery rather than the AC adapter, make sure that you set the *Battery Power Saving Mode* field in System Setup to *Non-Turbo*. This setting enables the microprocessor and the hard drive to slow down when the computer is idle.

You can also enable other power-saving options through System Setup. Set the timeout times in the *Standby Timeout* and *Suspend Timeout* fields to the shortest times to ensure maximum power savings.

Certain software programs “hang” during operations when there is no interaction with the keyboard or peripheral devices.

Your computer may be in standby or suspend mode. Tap the touchpad to resume from standby or press the power button to resume from suspend.

A serial or parallel device attached to a serial or parallel port on the rear panel of the system unit does not work properly.

Check the attached device. Is it turned on? Is the cable properly installed between the device and the port? If you are using an operating system that is not plug and play compliant, make sure the *Plug & Play O/S* field in System Setup is set to *No*. Check to make sure that the port is enabled in System Setup.

A PC Card does not work correctly.

Make sure that the PC Card is inserted right side up in the PC Card slot. Check that the card is inserted fully into the slot. If you are using a PC Card modem, check the modem cable connections. If you are using an operating system that is not plug and play compliant, make sure the *Plug & Play O/S* field in System Setup is set to *No*.

The System Setup settings are not retained when you turn off the computer.

The CMOS battery inside the computer may need to be replaced. The CMOS battery provides power to save the system BIOS information when the computer is turned off. Normally, the CMOS battery lasts for several years. Do not attempt to open the chassis and replace this battery yourself or your warranty is void. Have an authorized manufacturer’s service center replace the CMOS battery.

Infrared Problems

If your computer's operating system is Windows 98, you can enable and use the infrared port.

If you are unable to transfer files with the infrared port, check the following:

- The receiving device must be positioned properly. There must be no more than three feet of distance between the computer's infrared port and the receiving infrared device.
- The sending and receiving devices need to be on the same level vertically. Place them on the same table if possible.
- Make sure the infrared ports on the sending and receiving devices face each other, with no more than a 30° angle between the two infrared ports.
- Make sure that nothing is obstructing the file transfer path between the computer's infrared port and the receiving infrared device.
- Check to see if the *Infrared Port* field in System Setup is set to *2F8, IRQ3*.

If you still cannot transfer a file, see the documentation for the infrared software.

Using Options

You can order the following options for your computer from your authorised reseller:

- An extra AC adapter.
- An auto/airline adapter that enables you to charge the computer's battery and operate the computer while in an automobile or an airplane.
- An extra battery pack.
- An upgraded hard drive. Optional hard drives are available to fit in the hard drive compartment or the SmartBay.
- 16, 32, and 64 MB memory modules that enable you to upgrade your computer's memory.
- A battery cradle that charges the battery outside the computer.
- An external numeric keypad.
- A CD-ROM drive and floppy cable for computers that do not ship with these items.
- Docking options that enable you to use your computer like a desktop computer.

The options that are available may change periodically. Contact your reseller for updated information.

Auto/Airline Adapter

The auto/airline adapter enables you to power your computer and charge the computer battery

- In an automobile, through the +12 volt cigarette lighter socket.

Portable computer connectors on airplanes differ. You may need to remove the top of the adapter casing to use the adapter on certain airplanes.

To remove the top of the adapter casing:

1. Press and hold the release button on the adapter.
2. Pull the top of the adapter casing off.

Battery Pack

You can order another lithium-ion battery pack for your computer. See “Using the Battery” on page 34 for information on the battery.

Hard Drives

You can order optional hard drives for your system. A hard drive can be installed in the hard-drive compartment to replace your existing hard drive or you can order a hard drive that fits in the SmartBay. See “Installing a Hard Drive” on page 33 for information on installing a new drive in the hard-drive compartment. See “Using the SmartBay” on page 25 for information on installing a device in the SmartBay.

Memory Modules

You can increase system memory by installing optional memory modules. You can install 16, 32, or 64 MB SODIMM modules. Install memory modules in any combination of sizes.



To avoid possible system problems, use only approved memory modules in your computer.

Before You Install Memory



To prevent personal injury and damage to the equipment, follow the precautions listed here before installing a memory module.

- Before you remove the memory module compartment door, turn off the computer, unplug the AC adapter or auto/airline adapter, and remove the battery. Also, disconnect any peripheral devices.
- Before handling a memory module, discharge any static electricity by touching a grounded surface or using a grounding wrist strap.

- Do not insert objects with conductive material, such as metal screwdrivers or graphite pencils, into the memory-module compartment.

Installing a Memory Module



Handle memory modules carefully. Hold them only by the edges.

To install a memory module:

1. Turn the computer over so that the bottom faces up.
2. Using a Phillips screwdriver, remove the screw that holds the memory-module compartment door in place (Figure 20).

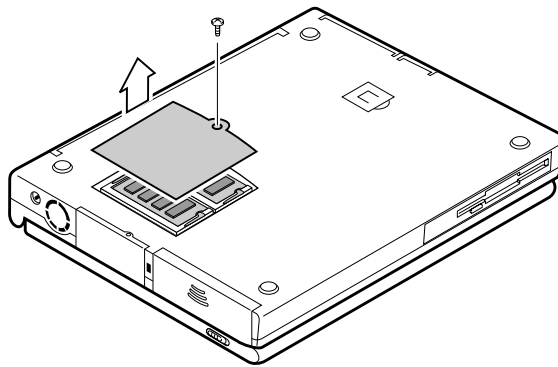

Figure 20. Removing the Memory Module Compartment Door

3. Grasp the edge of the door and pull the door off the chassis.
4. Remove installed modules if necessary:



When removing modules, pull on the plastic portion of the connector slots tabs only. Do not pull on the metal part of the tabs, or you may damage the tabs.

- a. Pull the tabs on the connector slot outward slightly, until the edge of the memory module pops up (Figure 21).

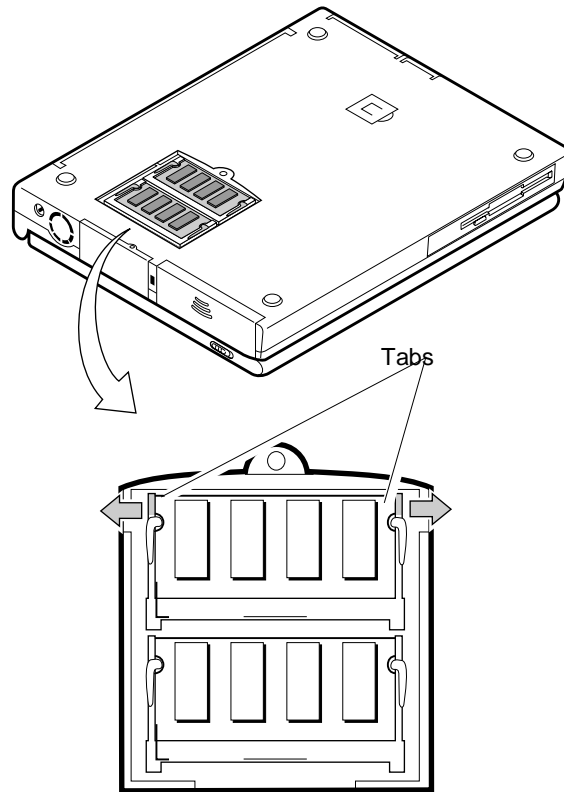

Figure 21. Removing a Memory Module

- b. Hold the memory module by the edges and pull it forward out of the compartment.

5. Align the connector on the memory module with the connector of the slot.
6. Push the memory module into the slot at a slight angle until the connectors are fully engaged (Figure 22).
7. Push down on the edge of the memory module until the module snaps into place.

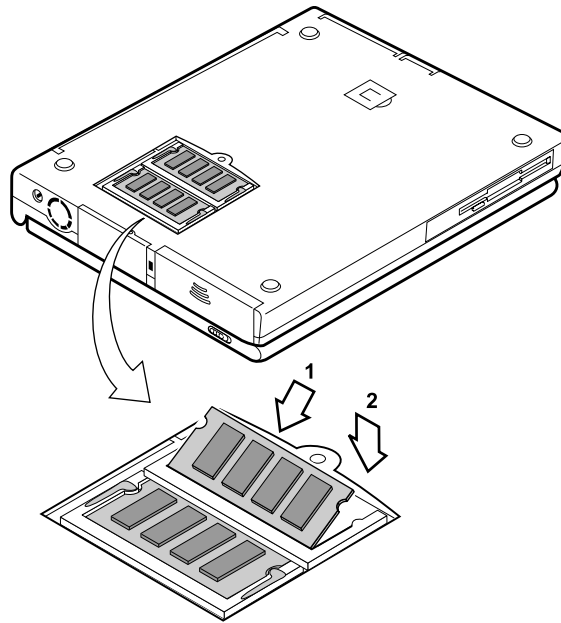

Figure 22. Installing a Memory Module

8. Align the memory module compartment door with the compartment and push the door down until it snaps into place.
9. Reinstall the screw you removed in step 2.
10. Turn on the computer and perform a complete POST to check the memory integrity.

Battery Cradle

The external battery cradle enables you to charge the computer battery outside of the computer.

To charge a battery in the battery cradle:

1. Insert the battery into the cradle, contact end first (Figure 23):

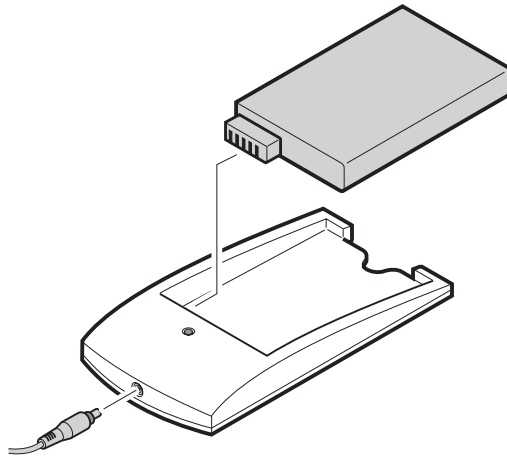

Figure 23. Battery Cradle

2. Attach the computer AC adapter to the connector at the back of the cradle, and plug the other end of the adapter into a grounded electrical outlet.

The indicator light on the cradle is green when the cradle's power is on. The light turns amber when the battery begins to charge.

3. When the indicator light on the cradle turns back to green, the battery is fully charged.

The battery is fully charged in approximately 3 hours.



Do not leave the battery cradle plugged into an electrical outlet for a long time if the battery cradle will not be used. Also do not store batteries in the battery cradle for a long time. Otherwise the battery or the battery cradle may be damaged.

External Numeric Keypad

The external numeric keypad has the same features as the integrated keypad. The external keypad plugs into the PS/2 mouse and keyboard port.

CD-ROM Drive and Floppy Cable

If your system did not ship with a CD-ROM drive included, you can order a drive and a floppy cable. See “Using the SmartBay” on page 25 for directions on installing the CD-ROM drive. See “Connecting the Floppy Drive to the Floppy Connector” on page 23 for directions on using the floppy cable.

Docking Options

Contact your reseller for a list of docking options available for your computer. User’s manuals are included with the docking options.

Specifications

Table 8 gives the specifications for your computer.

Table 8. System Specifications

Dimension	
System with 12.1 TFT LCD	
Width	12.1 in (30.9 cm)
Height	1.65 in (4.2 cm)
Length	9.5 in (24.1 cm)
Weight (with floppy drive and battery installed)	6.20 lbs (2.81Kg)
LCD viewing area (12.1 TFT)	9.7 x 7.2 in (246 x 184.5 mm)
System with 13.3 TFT LCD	
Width	12.1 in (30.9 cm)
Height	1.85 in (4.7 cm)
Length	9.5 in (24.1 cm)
Weight (with floppy drive and battery installed)	6.53 lbs (2.97Kg)
LCD viewing area (13.3 TFT)	10.6 x 7.9 in (270.3 x 202.8 mm)
Environment	
Ambient temperature, operating	41 ^o –95 ^o F (5 ^o –35 ^o C)
Ambient temperature, storage	14 ^o –112 ^o F (-10 ^o –44 ^o C)
Relative humidity (noncondensing), operating	20–80%
Relative humidity (noncondensing), storage	15–95%
Altitude, operating	0 to 8,000 ft (0 to 2,348 m)
Altitude, storage	0 to 40,000 ft (0 to 12,192 m)

Shock, operating	10 G for 11 ms half sine
Shock, nonoperating	60 G for 11 ms half sine

Smart Lithium-Ion Battery

Weight	0.84 lbs (0.38 Kg)
Nominal open circuit voltage	10.8 Vcc
Capacity, typical	4800mAhr, 52whr
Charging time, approximate, with computer turned off	3 hr
Charging time, approximate, with computer turned on	6 hr
Average battery life, with no power management enabled	3 hr

AC Adapter

Width	2.05 in (5.2 cm)
Height	1 in (2.6 cm)
Length	4.33 in (11 cm)
Weight	(0.21 kg)
Operating voltage	100 VAC to 240 VAC
Line frequency	50-60 Hz
Input current	1.3 A 100 V - 0.9 A 240 V
Output current	2.63A
Output voltage	19V

Abbreviations

Your documentation uses the following abbreviations:

A	Amperes
AC	Alternating current
APM	Advanced Power Management
ATA	AT attachment (refers to the hard-drive interface in an AT-compatible computer)
BBS	Bulletin board system
BIOS	Basic input/output system
C	Centigrade
CD	Compact disc
CD-ROM	Compact disc read-only memory
cm	Centimeters
COM	Communication (as in communication port)
CMOS	Complementary metal-oxide semiconductor
CMYK	Cyan-Magenta-Yellow-black
DC	Direct current
dBA	Decibels acoustic
DIN	Deutsche Industrie Normenuasschuss (German electrical standards association)
DMA	Direct memory access
DPMS	Display power-management signaling
DRAM	Dynamic random access memory
ECP	Extended capabilities port
EPP	Enhanced parallel port
F	Fahrenheit
FIR	Fast infrared
ft	Feet
g	gram

G Gravity
GB Gigabytes
hr hour
Hz Hertz
IDE Integrated drive electronics
in. Inches
I/O Input/Output
IrDA Infrared Data Association
IRQ Interrupt request line
Kb/sec Kilobits per second
KB Kilobytes
kg Kilograms
LAN Local-area network
lbs Pounds
LBA Logical block addressing
LCD Liquid-crystal display
m. Meters
mA Milliampere
mAh Milliampere hour
MB Megabyte
Mb/sec Megabits per second
MHz Megahertz
MIDI Musical instrument digital interface
mm millimeter
MPU Microprocessor unit
ms Millisecond
PDF Portable document format
PC Personal computer
PCI Peripheral component interconnect
PCMCIA Personal Computer Memory Card International Association
POST Power-on self-test

PS/2 Personal System/2
RAM Random-access memory
RGB Red-Green-Blue
ROM Read-only memory
SRAM Static random-access memory
SVGA Super video graphics array
TFT Thin-film transistor
USB Universal serial bus
V Volt
VAC Voltage alternating current
VCC Voltage collector current
VDC Voltage direct current
VGA Video graphics array
whr Watt hour
XGA Extended graphics array

Glossary

AC adapter

The AC (or alternating current) adapter regulates current coming into your computer from the wall outlet. The current at the wall outlet is alternating current and needs to be changed by the adapter to DC (direct current) before your computer can use it for power.

BIOS

BIOS stands for basic input/output system. The BIOS is software (often called firmware) that is independent of any operating system. It enables the computer to communicate with the screen, keyboard, and other peripheral devices without using programs on the hard disk.

The BIOS on your computer is flash BIOS, which means that it has been recorded on a flash memory chip that can be updated if needed.

Boot

To start your computer. A cold boot resets the entire computer and runs through all computer self-tests. A warm boot clears out computer memory only.

Boot disk

A disk containing operating system programs required to start your computer. A boot disk can be a floppy disk, hard drive, or compact disc.

Byte

The basic unit of measure for computer memory. A character—such as a letter of the alphabet—uses one byte of memory. Computer memory is often measured in kilobytes (1,024 bytes) or megabytes (1,048,576 bytes).

Each byte is made up of eight bits. For more information on bytes and bits, see an introductory book on computers.

Cache memory

Cache is very fast, zero-wait-state memory located between the microprocessor and main memory. Cache reduces the average time required for the microprocessor to get the data it needs from the main memory by storing recently accessed data in the cache.

CardBus

CardBus technology enables the computer to use 32-bit PC Cards. Hardware in the computer and the Windows 98 operating system provide support for the 32-bit cards. The voltage of 32-bit cards (3.3 volts) is lower than that of 16-bit cards (5 volts). The 32-bit cards can transmit more data at a time than the 16-bit cards, thus increasing their speed.

CMOS memory

CMOS (complementary metal oxide semiconductor) memory is powered by the CMOS battery. The System Setup settings and other parameters are maintained in CMOS memory. Even when you turn your computer off, the information in CMOS memory is saved.

COM port

COM stands for communication. COM ports are the serial ports in your computer.

Conventional memory

The first 640 KB of system memory. Operating systems and application programs can directly access this memory without using memory-management software.

CMYK

A color model in which all colors are described as a mixture of four process colors - Cyan, Magenta, Yellow and Black. CMYK is the standard color model used in offset printing for full-color documents. Printed colors look the same as what appears on the screen.

Disc

A compact disc (CD).

Disk

The device used by the computer to store and retrieve information. *Disk* can refer to a floppy disk, hard disk, or RAM disk.

Disk cache

A software device that accumulates copies of recently used disk sectors in RAM. The application program can then read these copies without accessing the disk. This, in turn, speeds up the performance of the application.

A cache is a buffer for transferring disk sectors in and out of RAM. Data stored in a disk cache is a copy of data already stored on the physical disk.

DMA (direct memory access)

A method of transferring data from a device to memory without having the data pass through the microprocessor. Using DMA can speed up system performance.

Floppy disk

A removable disk, also called *floppy* or *diskette*.

Hard drive

Also called *fixed* disk. A hard drive is connected to the computer and can be installed or removed. Data written to a hard drive remains until it is overwritten or corrupted.

The 2.5-inch hard drive in your computer was designed for use in a portable computer. Because hard drives in portable computers are smaller than those in desktop computers, their maximum storage capacity may be less than that of desktop hard drives. However, because of their smaller size, the drives handle shock and vibration better than larger drives, which is important for a portable computer.

I/O

Input/output. Refers to peripheral devices, such as printers, that are addressed through an I/O address.

I/O address

I/O stands for input/output. Peripheral devices, such as printers, are addressed through the I/O port address.

IRQ (interrupt request line)

The IRQ is a hardware line that a device uses to signal the microprocessor when the device needs the microprocessor's services. The number of IRQs is limited by industry standards.

LCD (liquid-crystal display)

The LCD screen on your computer differs from the display screen of a desktop monitor. Most desktop monitors use CRT (cathode-ray tube) displays, which work by moving an electron beam across phosphor dots on the back of the screen. The phosphor dots light up to show the image. LCDs use a liquid-crystal solution between two sheets of polarizing material. Electric current passing through the liquid aligns the crystals so that light can or cannot pass through them, creating an image.

MB

1,024 kilobytes.

Megabit

1,048,576 bits or about 128 kilobytes.

Operating system

A program that supervises the computer's operation, including handling I/O. Application programs and users can request operating-system services. A user might request operation-system services to copy files or format a disk. An application program might use the operating system to obtain keyboard input, write data to a file, or write data to a screen.

PC Card

PC Card stands for personal computer card. The Personal Computer Memory Card International Association (PCMCIA) defines the standards used to develop all PC Cards. PC Card types include: modems, Ethernet adapters, SCSI adapters, ATA cards, and memory cards.

PC slot

The PC slot is the hardware slot in the computer where the PC Card is placed.

Pixel

A pixel is an individual dot in a graphic displayed on your computer. The pixels are so close together that they look as though they are connected. An LCD screen displays thousands or millions of pixels.

Plug and Play

A plug and play operating system automatically configures computer components to work with your system. With this type of operating system, you normally do not need to set jumpers on devices or set memory addresses or IRQs.

POST

POST stands for power-on self-test. POST is a test performed by the computer whenever you turn on the power. POST checks system integrity.

RAM (random access memory)

The computer's system memory, including conventional and extended memory. You can write to and read from RAM. Information stored in RAM is temporary, and is erased when the system is turned off.

Refresh rate

The refresh rate is the rate at which the image on the LCD screen is rewritten to the screen. A fast refresh rate helps keep the image from flickering.

Resolution

The resolution is the sharpness or clarity of the image on your LCD screen. Resolution is measured by the number of pixels the computer's screen can display. For example, a resolution of 800x600 means that the screen can display 800 pixels in row and can display 600 rows. The more pixels displayed, the higher the resolution and the better the image.

ROM (read-only memory)

Permanent computer memory dedicated to a particular function. For example, the instructions for starting the computer when you first turn on power are contained in ROM. You cannot write to ROM. (ROM is not the same as RAM).

Sector

Also known as *disk sector*. The portion of a track that is numbered and can hold a specified number of characters (usually 512 KB).

Shadow RAM

A write-protected area of RAM that contains a copy of the BIOS. As the computer boots, the BIOS is copied from its permanent location in ROM to RAM. The BIOS can be executed much faster in RAM than in ROM. The BIOS remains in shadow RAM until you turn off the computer.

RGB

A color model generally used by display devices. Colors are described as a mixture of Red, Blue and Green.

TFT (thin film transistor) LCD

A TFT LCD uses a separate transistor circuit to control each pixel. This technology provides the best resolution for an LCD screen. A TFT LCD is also sometimes called an active matrix LCD.

Zoomed video

Zoomed video technology enables zoom video PC Card to transfer data directly from the card to video and audio systems without going through the microprocessor. This process improves video performance. Video conferencing

and real-time multimedia devices, such as video cameras, are supported by zoom video.