

FCC RF Test Report

APPLICANT : Samsung Electronics Co., Ltd.
EQUIPMENT : WCDMA Digital mobile phone
BRAND NAME : SAMSUNG
MODEL NAME : GT-S7272C
FCC ID : A3LGTS7272C
STANDARD : FCC 47 CFR Part 2, 22(H), 24(E)
CLASSIFICATION : PCS Licensed Transmitter Held to Ear (PCE)

The product was received on Nov. 26, 2013 and testing was completed on Dec. 19, 2013. We, SPORTON INTERNATIONAL (SHENZHEN) INC., would like to declare that the tested sample has been evaluated in accordance with the procedures given in ANSI / TIA / EIA-603-C-2004 and shown to be compliant with the applicable technical standards.

The test results in this report apply exclusively to the tested model / sample. Without written approval of SPORTON INTERNATIONAL (SHENZHEN) INC., the test report shall not be reproduced except in full.



Reviewed by: Joseph Lin / Supervisor

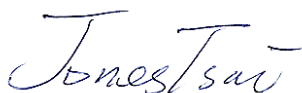

Approved by: Jones Tsai / Manager



Testing Laboratory
2353

SPORTON INTERNATIONAL (SHENZHEN) INC.

No. 3 Building, the third floor of south, Shahe River west, Fengzeyuan warehouse, Nanshan District, Shenzhen, Guangdong, P.R.C.



TABLE OF CONTENTS

| | |
|---|------------|
| REVISION HISTORY..... | 3 |
| SUMMARY OF TEST RESULT | 4 |
| 1 GENERAL DESCRIPTION | 5 |
| 1.1 Applicant..... | 5 |
| 1.2 Manufacturer | 5 |
| 1.3 Feature of Equipment Under Test..... | 5 |
| 1.4 Product Specification of Equipment Under Test | 5 |
| 1.5 Modification of EUT | 6 |
| 1.6 Maximum ERP/EIRP Power, Frequency Tolerance, and Emission Designator | 6 |
| 1.7 Testing Site | 6 |
| 1.8 Applied Standards..... | 6 |
| 2 TEST CONFIGURATION OF EQUIPMENT UNDER TEST..... | 7 |
| 2.1 Test Mode..... | 7 |
| 2.2 Connection Diagram of Test System | 9 |
| 2.3 Support Unit used in test configuration and system..... | 9 |
| 2.4 Measurement Results Explanation Example | 9 |
| 3 TEST RESULT..... | 10 |
| 3.1 Conducted Output Power Measurement..... | 10 |
| 3.2 Peak-to-Average Ratio | 12 |
| 3.3 Effective Radiated Power and Effective Isotropic Radiated Power Measurement | 18 |
| 3.4 99% Occupied Bandwidth and 26dB Bandwidth Measurement..... | 22 |
| 3.5 Band Edge Measurement..... | 36 |
| 3.6 Conducted Spurious Emission Measurement..... | 45 |
| 3.7 Field Strength of Spurious Radiation Measurement | 76 |
| 3.8 Frequency Stability Measurement..... | 102 |
| 4 LIST OF MEASURING EQUIPMENT | 107 |
| 5 UNCERTAINTY OF EVALUATION..... | 108 |

SUMMARY OF TEST RESULT

| Report Section | FCC Rule | Description | Limit | Result | Remark |
|----------------|-------------------------------------|---|-------------------------------------|--------|--|
| 3.1 | §2.1046 | Conducted Output Power | N/A | PASS | - |
| 3.2 | §24.232(d) | Peak-to-Average Ratio | < 13 dB | PASS | - |
| 0 | §22.913(a)(2) | Effective Radiated Power | < 7 Watts | PASS | - |
| 0 | §24.232(c) | Equivalent Isotropic Radiated Power | < 2 Watts | PASS | - |
| 3.4 | §2.1049 §22.917(a) §24.238(b) | Occupied Bandwidth | N/A | PASS | - |
| 3.5 | §2.1051 §22.917(a) §24.238(a) | Band Edge Measurement | < 43+10log ₁₀ (P[Watts]) | PASS | - |
| 3.6 | §2.1051 §22.917(a) §24.238(a) | Conducted Spurious Emission | < 43+10log ₁₀ (P[Watts]) | PASS | - |
| 3.7 | §2.1053 §22.917(a) §24.238(a) | Field Strength of Spurious Radiation | < 43+10log ₁₀ (P[Watts]) | PASS | Under limit 15.22 dB at 2546.400 MHz |
| 3.8 | §2.1055 §22.355 §24.235 | Frequency Stability for Temperature & Voltage | < 2.5 ppm | PASS | - |

1 General Description

1.1 Applicant

Samsung Electronics Co., Ltd.

No.9 WeiWu Rd., Micro Electronic Industrial Park, Jingang Highway, Xiqing District, Tianjin, China

1.2 Manufacturer

Samsung Electronics Co., Ltd.

No.9 WeiWu Rd., Micro Electronic Industrial Park, Jingang Highway, Xiqing District, Tianjin, China

1.3 Feature of Equipment Under Test

| Product Feature | |
|-----------------------------------|-------------------------------------|
| Equipment | WCDMA Digital mobile phone |
| Brand Name | SAMSUNG |
| Model Name | GT-S7272C |
| FCC ID | A3LGTS7272C |
| GSM Operating Band(s) | GSM 850/900/1800/1900MHz |
| GPRS/EGPRS Multislot Class | GPRS Class 33, EGPRS Class 33 |
| WCDMA Operating Band(s) | FDD Band I/VIII |
| Wi-Fi Specification | 2.4GHz 802.11b/g/n HT20 |
| Bluetooth Version | Bluetooth v3.0 + EDR/Bluetooth v4.0 |
| HW Version | REV1.0 |
| SW Version | S7272C.001 |
| EUT Stage | Pre-Production |

Remark: The above EUT's information was declared by manufacturer. Please refer to the specifications or user's manual for more detailed description.

1.4 Product Specification of Equipment Under Test

| Product Specification subjective to this standard | |
|---|---|
| Tx Frequency | GSM850: 824.2 MHz ~ 848.8 MHz GSM1900: 1850.2 MHz ~ 1909.8MHz |
| Rx Frequency | GSM850: 869.2 MHz ~ 893.8 MHz GSM1900: 1930.2 MHz ~ 1989.8 MHz |
| Maximum Output Power to Antenna | GSM850 : 32.32 dBm GSM1900 : 30.52 dBm |
| Antenna Type | SPRING Contact Antenna |
| Type of Modulation | GSM: GMSK GPRS: GMSK EDGE: GMSK / 8PSK (Downlink Only) |

1.5 Modification of EUT

No modifications are made to the EUT during all test items.

1.6 Maximum ERP/EIRP Power, Frequency Tolerance, and Emission Designator

| FCC Rule | System | Type of Modulation | Maximum ERP/EIRP (W) | Frequency Tolerance (ppm) | Emission Designator |
|----------|-------------|--------------------|----------------------|---------------------------|---------------------|
| Part 22 | GSM850 GSM | GMSK | 0.1361 | 0.02 ppm | 248KGXW |
| Part 24 | GSM1900 GSM | GMSK | 0.8851 | 0.01 ppm | 246KGXW |

1.7 Testing Site

| | | | |
|---------------------------|---|-----------|-----------------------------|
| Test Site | SPORTON INTERNATIONAL (SHENZHEN) INC. | | |
| Test Site Location | No. 3 Building, the third floor of south, Shahe River west, Fengzeyuan warehouse, Nanshan District, Shenzhen, Guangdong, P.R.C. TEL: +86-755-3320-2398 | | |
| Test Site No. | Sporton Site No. | | FCC Registration No. |
| | TH01-SZ | 03CH01-SZ | 831040 |

1.8 Applied Standards

According to the specifications of the manufacturer, the EUT must comply with the requirements of the following standards:

- FCC 47 CFR Part 2, 22(H), 24(E)
- ANSI / TIA / EIA-603-C-2004
- FCC KDB 971168 D01 Power Meas. License Digital Systems v02r01

Remark:

1. All test items were verified and recorded according to the standards and without any deviation during the test.
2. This EUT has also been tested and complied with the requirements of FCC Part 15, Subpart B, recorded in a separate test report.

2 Test Configuration of Equipment Under Test

2.1 Test Mode

During all testing, EUT is in link mode with base station emulator at maximum power level. The spurious emission measurements were carried out in semi-anechoic chamber with 3-meter test range, and EUT was rotated on three test planes to find out the worst emission (Z plane).

Frequency range investigated for radiated emission is as follows:

1. 30 MHz to 9000 MHz for GSM850.
2. 30 MHz to 19000 MHz for GSM1900.

| Test Modes | | |
|------------|--------------|---------------|
| Band | Radiated TCs | Conducted TCs |
| GSM 850 | ■ GSM Link | ■ GSM Link |
| GSM 1900 | ■ GSM Link | ■ GSM Link |

Note: We select the highest output power of each modulation to perform all testing, i.e., GSM mode for GMSK modulation.



The conducted power tables are as follows:

<SIM1>

| Conducted Power (*Unit: dBm) | | | | | | |
|------------------------------|--------|-------|-------|---------|--------|--------|
| Band | GSM850 | | | GSM1900 | | |
| Channel | 128 | 189 | 251 | 512 | 661 | 810 |
| Frequency | 824.2 | 836.4 | 848.8 | 1850.2 | 1880.0 | 1909.8 |
| GSM | 32.32 | 32.06 | 32.17 | 30.52 | 29.13 | 30.40 |
| GPRS class 8 | 32.31 | 32.02 | 32.16 | 30.51 | 29.08 | 30.38 |
| GPRS class 10 | 30.24 | 30.20 | 30.22 | 27.66 | 26.12 | 27.07 |
| GPRS class 11 | 29.09 | 28.98 | 29.05 | 25.70 | 24.25 | 25.64 |
| GPRS class 12 | 27.36 | 27.25 | 27.23 | 24.47 | 23.01 | 24.26 |

<SIM2>

| Conducted Power (*Unit: dBm) | | | | | | |
|------------------------------|--------|-------|-------|---------|--------|--------|
| Band | GSM850 | | | GSM1900 | | |
| Channel | 128 | 189 | 251 | 512 | 661 | 810 |
| Frequency | 824.2 | 836.4 | 848.8 | 1850.2 | 1880.0 | 1909.8 |
| GSM | 32.30 | 32.03 | 32.14 | 30.51 | 29.11 | 30.38 |
| GPRS class 8 | 32.29 | 32.01 | 32.13 | 30.50 | 29.07 | 30.36 |
| GPRS class 10 | 30.23 | 30.17 | 30.20 | 27.65 | 26.10 | 27.05 |
| GPRS class 11 | 29.08 | 28.97 | 29.04 | 25.67 | 24.24 | 25.61 |
| GPRS class 12 | 27.33 | 27.24 | 27.21 | 24.45 | 23.00 | 24.24 |

2.2 Connection Diagram of Test System

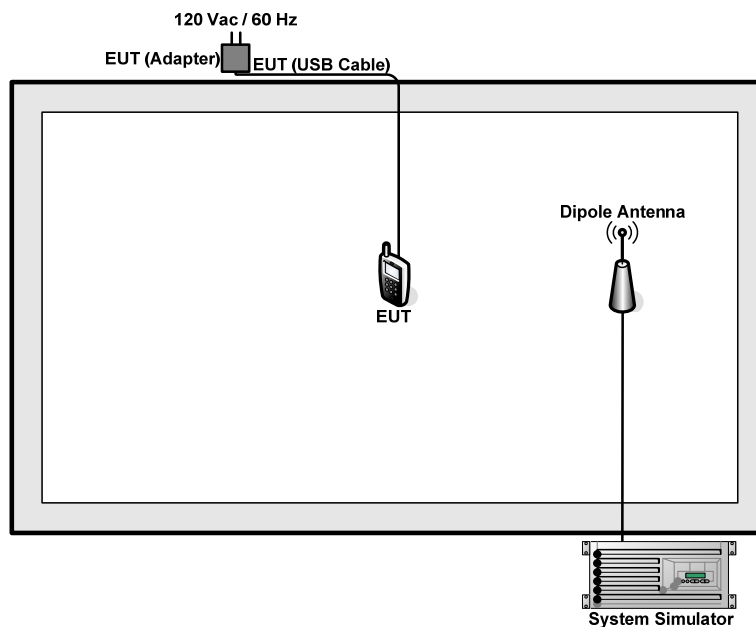

2.3 Support Unit used in test configuration and system

| Item | Equipment | Trade Name | Model No. | FCC ID | Data Cable | Power Cord |
|------|------------------|------------|-----------|--------|------------|-------------------|
| 1. | System Simulator | R&S | CMU 200 | N/A | N/A | Unshielded, 1.8 m |
| 2. | DC Power Supply | TOPWORD | 3303DR | N/A | N/A | Unshielded, 1.8 m |

2.4 Measurement Results Explanation Example

For all conducted test items:

The offset level is set in the spectrum analyzer to compensate the RF cable loss and attenuator factor between EUT conducted output port and spectrum analyzer. With the offset compensation, the spectrum analyzer reading level is exactly the EUT RF output level.

Example:

The spectrum analyzer offset is derived from RF cable loss and attenuator factor.

Offset = RF cable loss + attenuator factor.

Following shows an offset computation example with cable loss 8.5 dB and 10dB attenuator.

$$\begin{aligned} \text{Offset(dB)} &= \text{RF cable loss(dB)} + \text{attenuator factor(dB)} \\ &= 8.5 + 10 = 18.5 \text{ (dB)} \end{aligned}$$

3 Test Result

3.1 Conducted Output Power Measurement

3.1.1 Description of the Conducted Output Power Measurement

A base station simulator was used to establish communication with the EUT. Its parameters were set to transmit the maximum power on the EUT. The measured power in the radio frequency on the transmitter output terminals shall be reported.

3.1.2 Measuring Instruments

The measuring equipment is listed in the section 4 of this test report.

3.1.3 Test Procedures

1. The transmitter output port was connected to base station.
2. Set EUT at maximum power through base station.
3. Select lowest, middle, and highest channels for each band and different modulation.
4. Measure the maximum burst average power for GSM and maximum average power for other modulation signal.

3.1.4 Test Setup

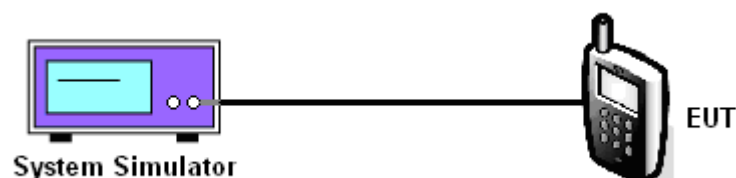

3.1.5 Test Result of Conducted Output Power

<SIM1>

| Cellular Band | | | |
|-------------------------|--------------|-----------|------------|
| Modes | GSM850 (GSM) | | |
| Channel | 128 (Low) | 189 (Mid) | 251 (High) |
| Frequency (MHz) | 824.2 | 836.4 | 848.8 |
| Conducted Power (dBm) | 32.32 | 32.06 | 32.17 |
| Conducted Power (Watts) | 1.71 | 1.61 | 1.65 |

| PCS Band | | | |
|-------------------------|---------------|-----------|------------|
| Modes | GSM1900 (GSM) | | |
| Channel | 512 (Low) | 661 (Mid) | 810 (High) |
| Frequency (MHz) | 1850.2 | 1880 | 1909.8 |
| Conducted Power (dBm) | 30.52 | 29.13 | 30.40 |
| Conducted Power (Watts) | 1.13 | 0.82 | 1.10 |

<SIM2>

| Cellular Band | | | |
|-------------------------|--------------|-----------|------------|
| Modes | GSM850 (GSM) | | |
| Channel | 128 (Low) | 189 (Mid) | 251 (High) |
| Frequency (MHz) | 824.2 | 836.4 | 848.8 |
| Conducted Power (dBm) | 32.30 | 32.03 | 32.14 |
| Conducted Power (Watts) | 1.70 | 1.60 | 1.64 |

| PCS Band | | | |
|-------------------------|---------------|-----------|------------|
| Modes | GSM1900 (GSM) | | |
| Channel | 512 (Low) | 661 (Mid) | 810 (High) |
| Frequency (MHz) | 1850.2 | 1880 | 1909.8 |
| Conducted Power (dBm) | 30.51 | 29.11 | 30.38 |
| Conducted Power (Watts) | 1.12 | 0.81 | 1.09 |

Note: Maximum burst average power for GSM.

3.2 Peak-to-Average Ratio

3.2.1 Description of the PAR Measurement

The peak-to-average ratio (PAR) of the transmission may not exceed 13 dB.

3.2.2 Measuring Instruments

The measuring equipment is listed in the section 4 of this test report.

3.2.3 Test Procedures

1. The EUT was connected to Spectrum Analyzer and System Simulator via power divider.
2. For GSM/EGPRS operating modes:
 - a. Set EUT in maximum power output.
 - b. Set the RBW = 1MHz, VBW = 3MHz, Peak detector in spectrum analyzer for first trace.
 - c. Set the RBW = 1MHz, VBW = 3MHz, RMS detector in spectrum analyzer for second trace.
 - d. The wanted burst signal is triggered by spectrum analyzer, and measured respectively the peak level and Mean level without burst-off time, after system simulator synchronized with the spectrum analyzer.
3. For UMTS operating modes:
 - a. Set the CCDF (Complementary Cumulative Distribution Function) option in spectrum analyzer.
 - b. The highest RF powers were measured and recorded the maximum PAPR level associated with a probability of 0.1 %.
4. Record the deviation as Peak to Average Ratio.

3.2.4 Test Setup

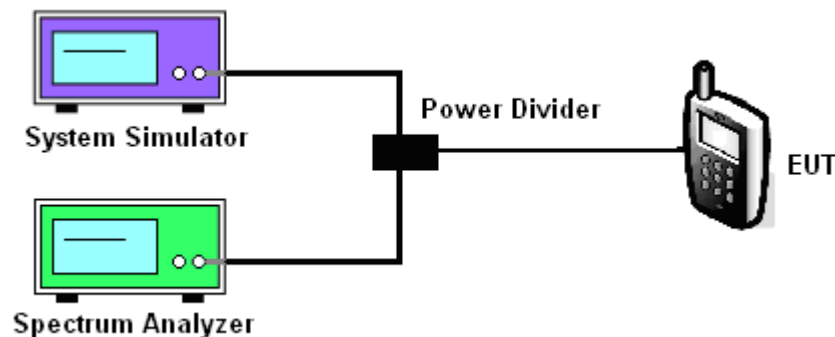

3.2.5 Test Result of Peak-to-Average Ratio

<SIM1>

| PCS Band | | | |
|----------------------------|---------------|-----------|------------|
| Modes | GSM1900 (GSM) | | |
| Channel | 512 (Low) | 661 (Mid) | 810 (High) |
| Frequency (MHz) | 1850.2 | 1880 | 1909.8 |
| Peak-to-Average Ratio (dB) | 0.48 | 0.44 | 0.52 |

<SIM2>

| PCS Band | | | |
|----------------------------|---------------|-----------|------------|
| Modes | GSM1900 (GSM) | | |
| Channel | 512 (Low) | 661 (Mid) | 810 (High) |
| Frequency (MHz) | 1850.2 | 1880 | 1909.8 |
| Peak-to-Average Ratio (dB) | 0.47 | 0.43 | 0.51 |



3.2.6 Test Result (Plots) of Peak-to-Average Ratio

<SIM1>

| | | | |
|--------|----------|-------------|-----------------|
| Band : | GSM 1900 | Test Mode : | GSM Link (GMSK) |
|--------|----------|-------------|-----------------|

Peak-to-Average Ratio on Channel 512 (1850.2 MHz)

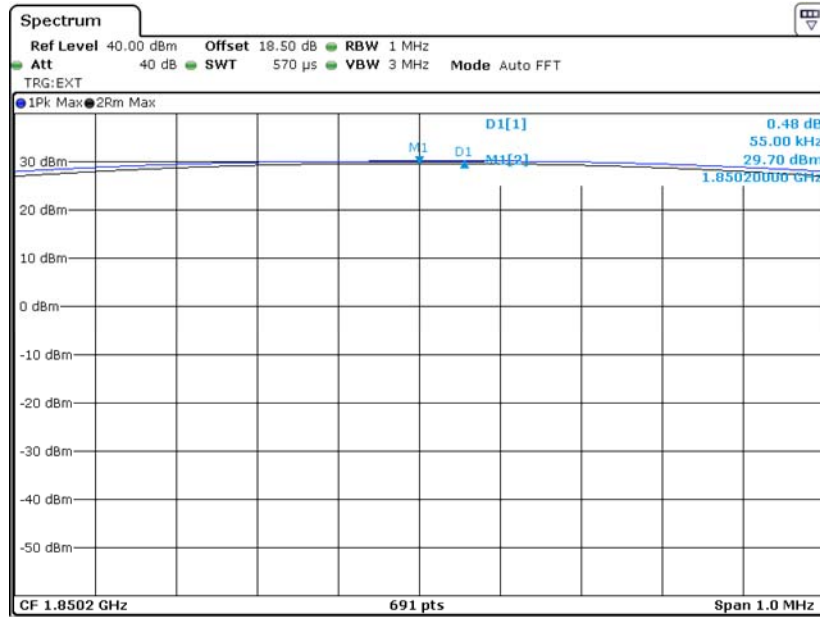

Date: 1.DEC.2013 10:14:37

Peak-to-Average Ratio on Channel 661 (1880.0 MHz)

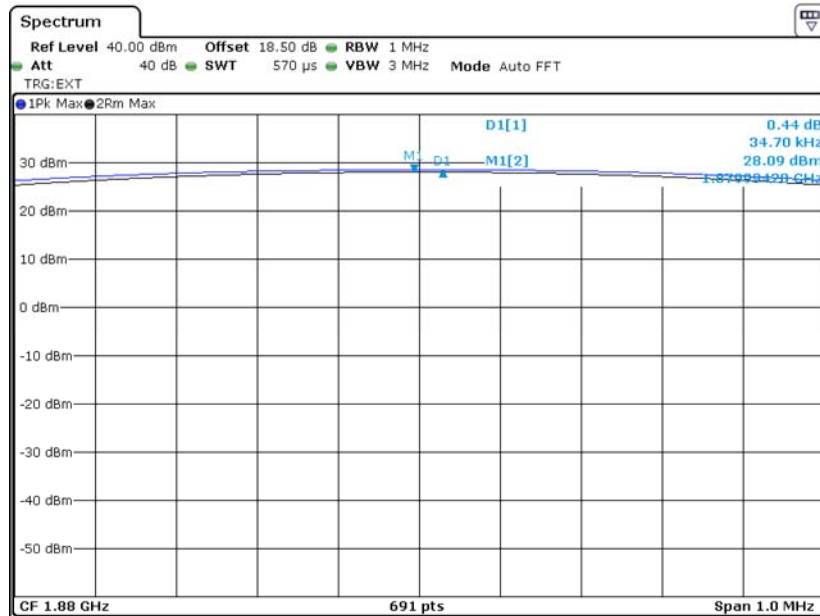

Date: 1.DEC.2013 10:13:49



Peak-to-Average Ratio on Channel 810 (1909.8 MHz)

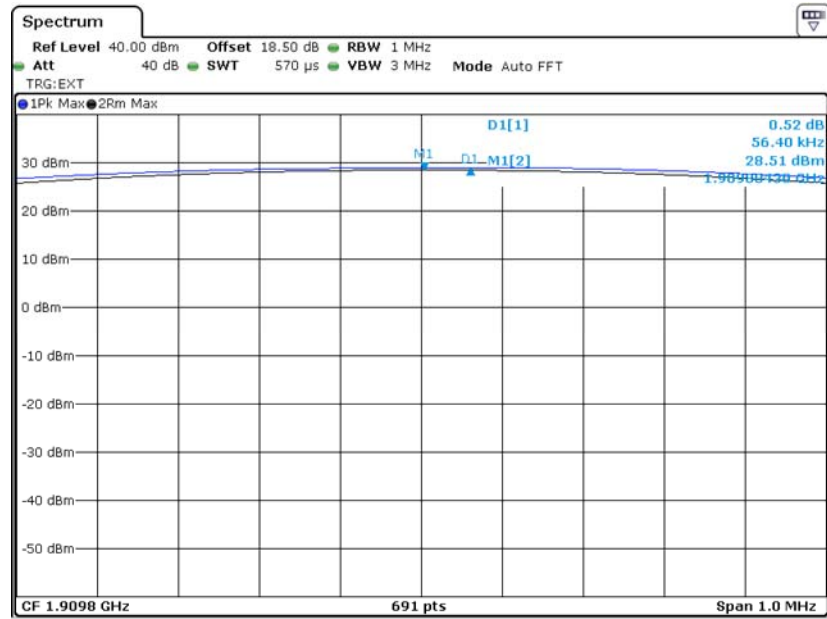

Date: 1.DEC.2013 10:15:13



<SIM2>

| | | | |
|--------|----------|-------------|-----------------|
| Band : | GSM 1900 | Test Mode : | GSM Link (GMSK) |
|--------|----------|-------------|-----------------|

Peak-to-Average Ratio on Channel 512 (1850.2 MHz)

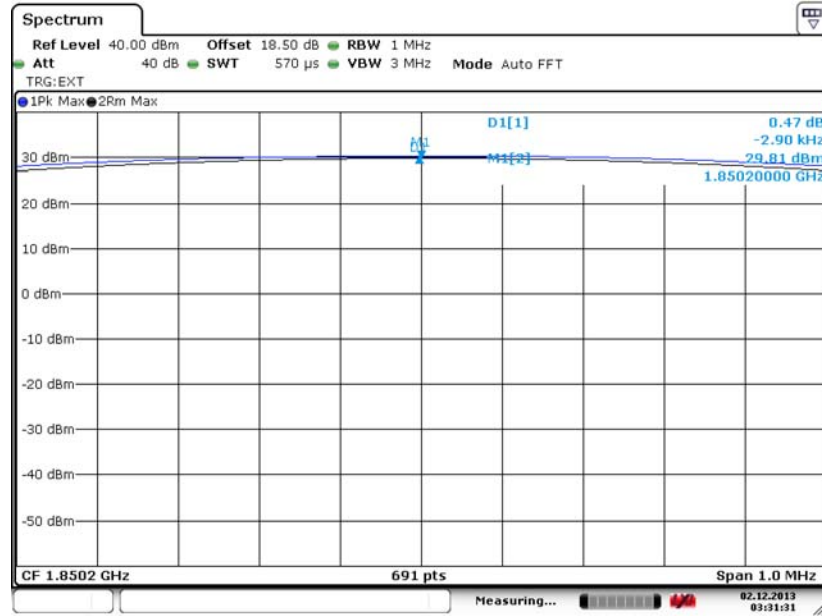

Date: 2.DEC.2013 03:31:31

Peak-to-Average Ratio on Channel 661 (1880.0 MHz)

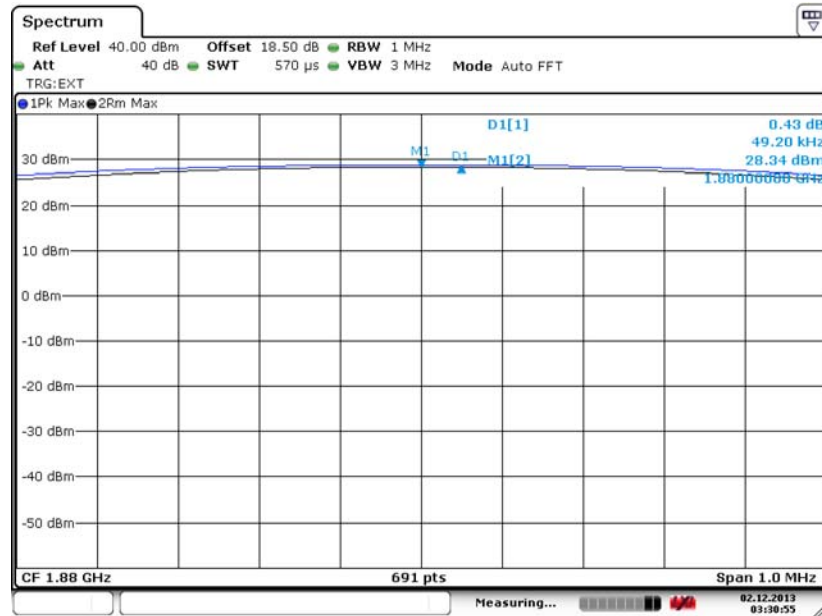

Date: 2.DEC.2013 03:30:55



Peak-to-Average Ratio on Channel 810 (1909.8 MHz)

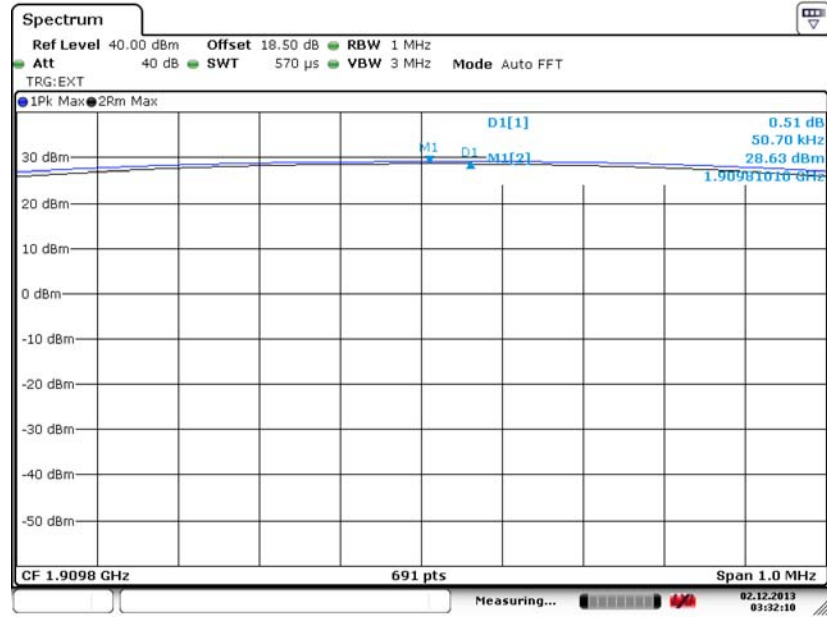

Date: 2.DEC.2013 03:32:10

3.3 Effective Radiated Power and Effective Isotropic Radiated Power Measurement

3.3.1 Description of the ERP/EIRP Measurement

The substitution method, in ANSI / TIA / EIA-603-C-2004, was used for ERP/EIRP measurement, and the spectrum analyzer configuration follows KDB 971168 D01 Power Meas. License Digital Systems v02r01. The ERP of mobile transmitters must not exceed 7 Watts and the EIRP of mobile transmitters are limited to 2 Watts.

3.3.2 Measuring Instruments

The measuring equipment is listed in the section 4 of this test report.

3.3.3 Test Procedures

1. The EUT was placed on a non-conductive rotating platform with 0.8 meter height in a semi-anechoic chamber. The radiated emission at the fundamental frequency was measured at 3 m with a test antenna and a spectrum analyzer with RBW= 1MHz, VBW= 3MHz for GSM, RBW= 100 kHz, VBW= 300 kHz, used channel power option with bandwidth=5MHz for WCDMA, and RMS detector settings per KDB 971168 D01.
2. During the measurement, the EUT was enforced in maximum power and linked with a base station. The highest emission was recorded from analyzer power level (LVL) from the 360 degrees rotation of the turntable and the test antenna raised and lowered over a range from 1 to 4 meters in both horizontally and vertically polarized orientations.
3. Effective Isotropic Radiated Power (EIRP) was measured by substitution method according to TIA/EIA-603-C. The EUT was replaced by dipole antenna (substitution antenna) at same location, and then a known power from S.G. was applied into the dipole antenna through a Tx cable, and then recorded the maximum Analyzer reading through raised and lowered the test antenna. The correction factor (in dB) = S.G. - Tx Cable loss + Substitution antenna gain - Analyzer reading. Then the EUT's EIRP was calculated with the correction factor, $EIRP = LVL + \text{Correction factor}$ and $ERP = EIRP - 2.15$.

3.3.4 Test Setup

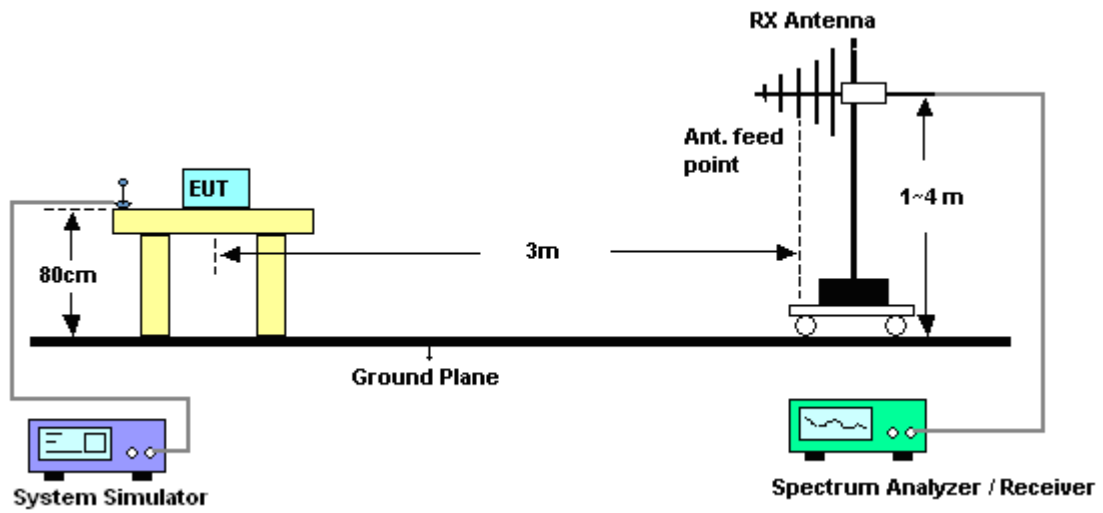

3.3.5 Test Result of ERP

<SIM1>

| GSM850 (GSM) Radiated Power ERP | | | | |
|---------------------------------|-----------|------------------------|-----------|---------|
| Horizontal Polarization | | | | |
| Frequency (MHz) | LVL (dBm) | Correction Factor (dB) | ERP (dBm) | ERP (W) |
| 824.2 | -5.31 | 28.798 | 21.34 | 0.1361 |
| 836.4 | -5.34 | 28.577 | 21.09 | 0.1284 |
| 848.8 | -4.84 | 28.064 | 21.07 | 0.1281 |
| Vertical Polarization | | | | |
| Frequency (MHz) | LVL (dBm) | Correction Factor (dB) | ERP (dBm) | ERP (W) |
| 824.2 | -18.97 | 32.596 | 11.48 | 0.0140 |
| 836.4 | -18.58 | 31.952 | 11.22 | 0.0132 |
| 848.8 | -17.82 | 31.561 | 11.59 | 0.0144 |

* ERP = LVL (dBm) + Correction Factor (dB) – 2.15

<SIM2>

| GSM850 (GSM) Radiated Power ERP | | | | |
|---------------------------------|-----------|------------------------|-----------|---------|
| Horizontal Polarization | | | | |
| Frequency (MHz) | LVL (dBm) | Correction Factor (dB) | ERP (dBm) | ERP (W) |
| 824.2 | -5.36 | 28.798 | 21.29 | 0.1345 |
| 836.4 | -5.31 | 28.577 | 21.12 | 0.1293 |
| 848.8 | -4.76 | 28.064 | 21.15 | 0.1304 |
| Vertical Polarization | | | | |
| Frequency (MHz) | LVL (dBm) | Correction Factor (dB) | ERP (dBm) | ERP (W) |
| 824.2 | -17.80 | 32.596 | 12.65 | 0.0184 |
| 836.4 | -18.51 | 31.952 | 11.29 | 0.0135 |
| 848.8 | -17.32 | 31.561 | 12.09 | 0.0162 |

* ERP = LVL (dBm) + Correction Factor (dB) – 2.15

3.3.6 Test Result of EIRP

<SIM1>

| GSM1900 (GSM) Radiated Power EIRP | | | | |
|-----------------------------------|-----------|------------------------|------------|----------|
| Horizontal Polarization | | | | |
| Frequency (MHz) | LVL (dBm) | Correction Factor (dB) | EIRP (dBm) | EIRP (W) |
| 1850.2 | -14.41 | 42.33 | 27.92 | 0.6194 |
| 1880.0 | -14.76 | 43.26 | 28.50 | 0.7079 |
| 1909.8 | -13.82 | 43.11 | 29.29 | 0.8492 |
| Vertical Polarization | | | | |
| Frequency (MHz) | LVL (dBm) | Correction Factor (dB) | EIRP (dBm) | EIRP (W) |
| 1850.2 | -21.98 | 44.96 | 22.98 | 0.1986 |
| 1880.0 | -21.52 | 45.13 | 23.61 | 0.2296 |
| 1909.8 | -21.50 | 45.47 | 23.97 | 0.2495 |

* EIRP = LVL (dBm) + Correction Factor (dB)

<SIM2>

| GSM1900 (GSM) Radiated Power EIRP | | | | |
|-----------------------------------|-----------|------------------------|------------|----------|
| Horizontal Polarization | | | | |
| Frequency (MHz) | LVL (dBm) | Correction Factor (dB) | EIRP (dBm) | EIRP (W) |
| 1850.2 | -14.25 | 42.33 | 28.08 | 0.6427 |
| 1880.0 | -14.62 | 43.26 | 28.64 | 0.7311 |
| 1909.8 | -13.64 | 43.11 | 29.47 | 0.8851 |
| Vertical Polarization | | | | |
| Frequency (MHz) | LVL (dBm) | Correction Factor (dB) | EIRP (dBm) | EIRP (W) |
| 1850.2 | -21.94 | 44.96 | 23.02 | 0.2004 |
| 1880.0 | -21.89 | 45.13 | 23.24 | 0.2109 |
| 1909.8 | -21.97 | 45.47 | 23.50 | 0.2239 |

* EIRP = LVL (dBm) + Correction Factor (dB)

3.4 99% Occupied Bandwidth and 26dB Bandwidth Measurement

3.4.1 Description of 99% Occupied Bandwidth and 26dB Bandwidth Measurement

The 99% occupied bandwidth is the width of a frequency band such that, below the lower and above the upper frequency limits, the mean powers emitted are each equal to a specified percentage 0.5% of the total mean transmitted power.

The emission bandwidth is defined as the width of the signal between two points, located at the 2 sides of the carrier frequency, outside of which all emissions are attenuated at least 26 dB below the transmitter power.

3.4.2 Measuring Instruments

The measuring equipment is listed in the section 4 of this test report.

3.4.3 Test Procedures

1. The EUT was connected to Spectrum Analyzer and Base Station via power divider.
2. The RF output of EUT was connected to the spectrum analyzer by RF cable and attenuator. The path loss was compensated to the results for each measurement.
3. The 99% occupied bandwidth were measured, set RBW= 1% of span, VBW= 3*RBW, sample detector, trace maximum hold.
4. The 26dB bandwidth were measured, set RBW= 1% of EBW, VBW= 3*RBW, peak detector, trace maximum hold.

3.4.4 Test Setup

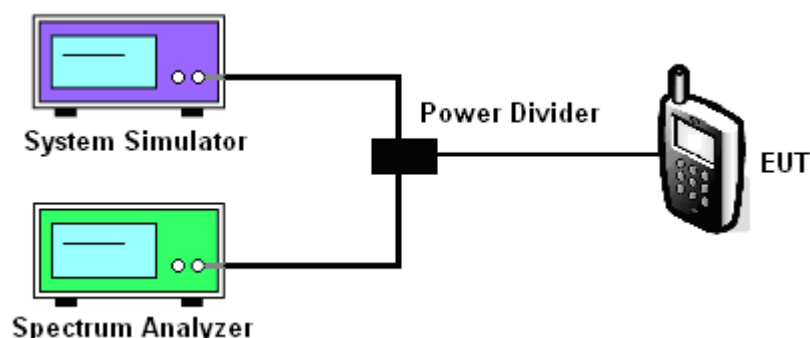

3.4.5 Test Result of 99% Occupied Bandwidth and 26dB Bandwidth

<SIM1>

| Cellular Band | | | |
|-----------------|--------------|-----------|------------|
| Modes | GSM850 (GSM) | | |
| Channel | 128 (Low) | 189 (Mid) | 251 (High) |
| Frequency (MHz) | 824.2 | 836.4 | 848.8 |
| 99% OBW (kHz) | 244.00 | 244.00 | 246.00 |
| 26dB BW (kHz) | 312.00 | 310.00 | 310.00 |

| PCS Band | | | |
|-----------------|---------------|-----------|------------|
| Modes | GSM1900 (GSM) | | |
| Channel | 512 (Low) | 661 (Mid) | 810 (High) |
| Frequency (MHz) | 1850.2 | 1880 | 1909.8 |
| 99% OBW (kHz) | 242.00 | 246.00 | 246.00 |
| 26dB BW (kHz) | 298.00 | 314.00 | 312.00 |

<SIM2>

| Cellular Band | | | |
|-----------------|--------------|-----------|------------|
| Modes | GSM850 (GSM) | | |
| Channel | 128 (Low) | 189 (Mid) | 251 (High) |
| Frequency (MHz) | 824.2 | 836.4 | 848.8 |
| 99% OBW (kHz) | 248.00 | 246.00 | 244.00 |
| 26dB BW (kHz) | 304.00 | 304.00 | 314.00 |

| PCS Band | | | |
|-----------------|---------------|-----------|------------|
| Modes | GSM1900 (GSM) | | |
| Channel | 512 (Low) | 661 (Mid) | 810 (High) |
| Frequency (MHz) | 1850.2 | 1880 | 1909.8 |
| 99% OBW (kHz) | 244.00 | 244.00 | 242.00 |
| 26dB BW (kHz) | 312.00 | 308.00 | 310.00 |

3.4.6 Test Result (Plots) of 99% Occupied Bandwidth and 26dB Bandwidth

<SIM1>

| | | | |
|--------|---------|-------------|-----------------|
| Band : | GSM 850 | Test Mode : | GSM Link (GMSK) |
|--------|---------|-------------|-----------------|

99% Occupied Bandwidth Plot on Channel 128 (824.2 MHz)

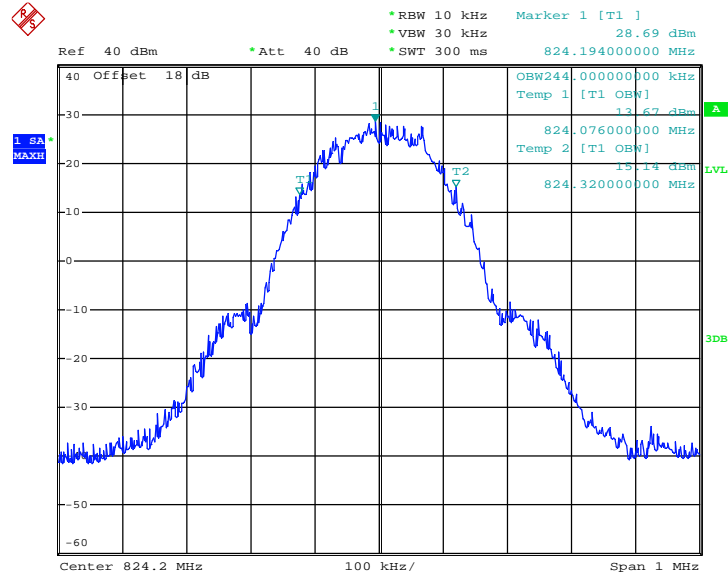

Date: 1.DEC.2013 14:22:28

26dB Bandwidth Plot on Channel 128 (824.2 MHz)

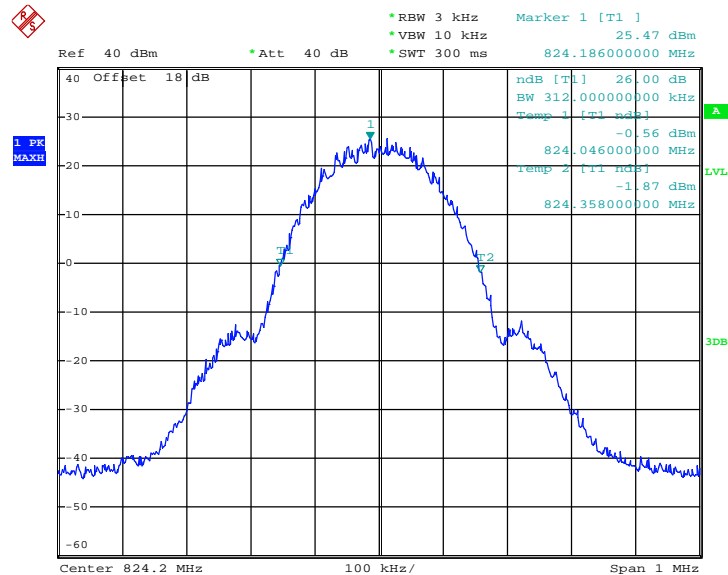

Date: 1.DEC.2013 14:16:30



99% Occupied Bandwidth Plot on Channel 189 (836.4 MHz)

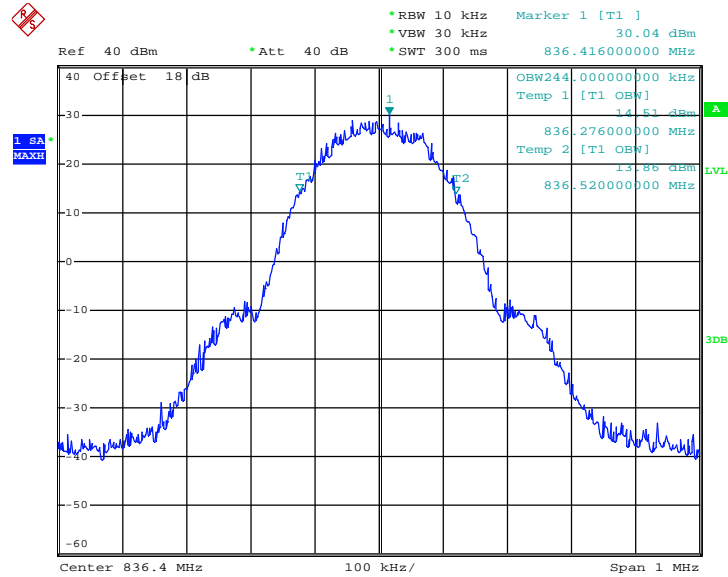

Date: 1.DEC.2013 14:25:40

26dB Bandwidth Plot on Channel 189 (836.4 MHz)

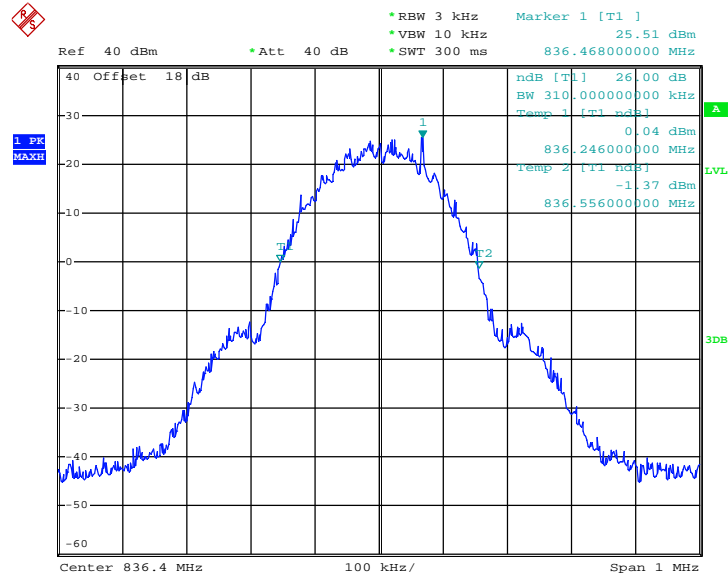

Date: 1.DEC.2013 14:17:37



99% Occupied Bandwidth Plot on Channel 251 (848.8 MHz)

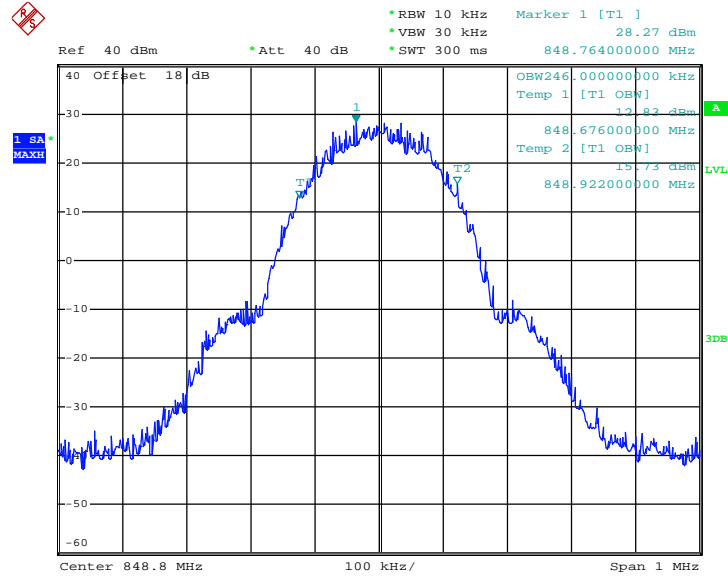

Date: 1.DEC.2013 14:28:47

26dB Bandwidth Plot on Channel 251 (848.8 MHz)

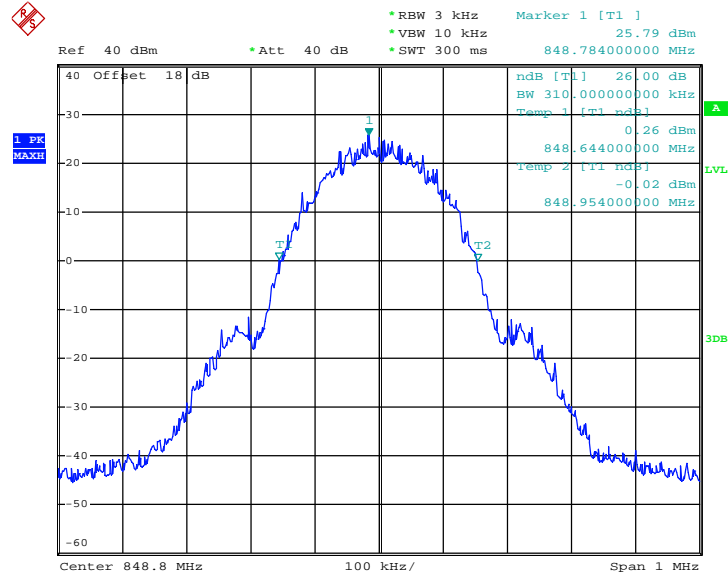

Date: 1.DEC.2013 14:18:26



| | | | |
|--------|----------|-------------|-----------------|
| Band : | GSM 1900 | Test Mode : | GSM Link (GMSK) |
|--------|----------|-------------|-----------------|

99% Occupied Bandwidth Plot on Channel 512 (1850.2 MHz)

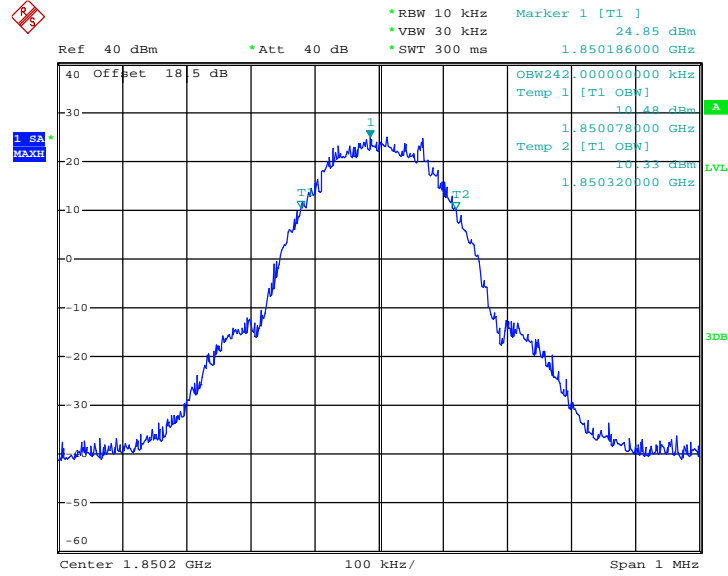

Date: 1.DEC.2013 15:18:52

26dB Bandwidth Plot on Channel 512 (1850.2 MHz)

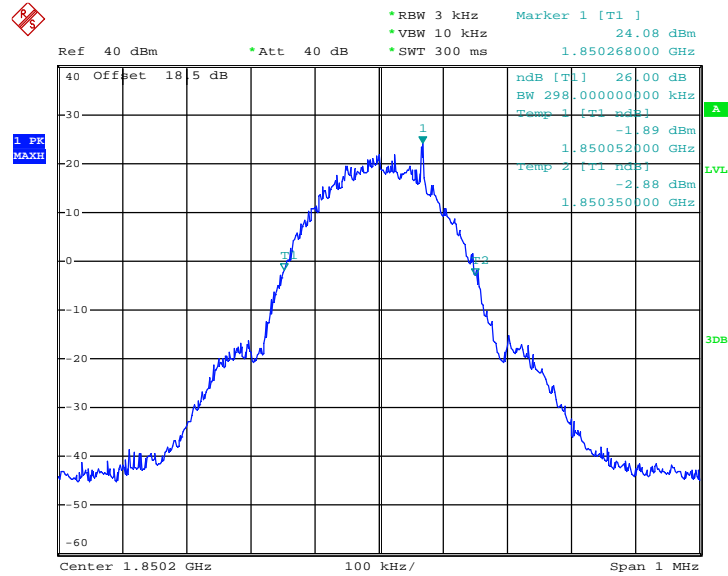

Date: 1.DEC.2013 15:07:13



99% Occupied Bandwidth Plot on Channel 661 (1880.0 MHz)

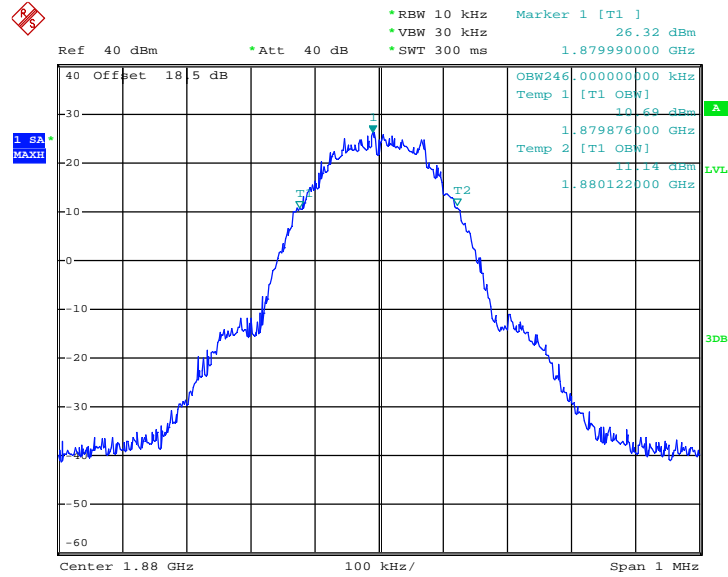

Date: 1.DEC.2013 15:15:56

26dB Bandwidth Plot on Channel 661 (1880.0 MHz)

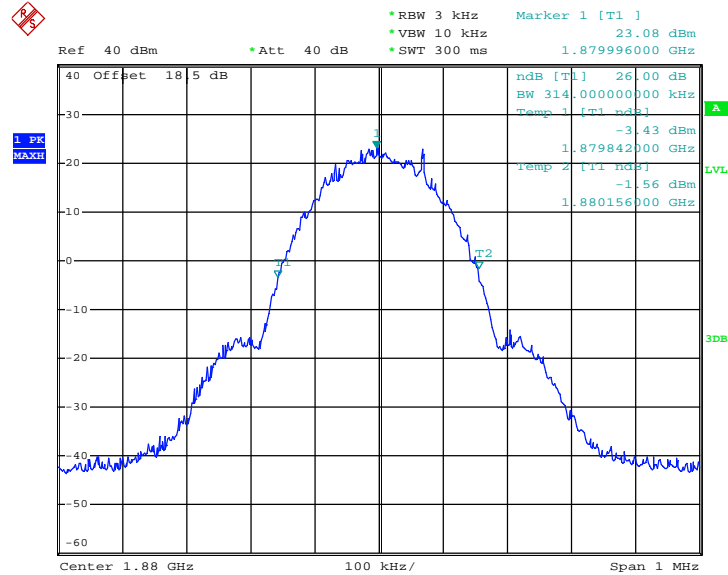

Date: 1.DEC.2013 15:04:51



<SIM2>

| | | | |
|--------|---------|-------------|-----------------|
| Band : | GSM 850 | Test Mode : | GSM Link (GMSK) |
|--------|---------|-------------|-----------------|

99% Occupied Bandwidth Plot on Channel 128 (824.2 MHz)

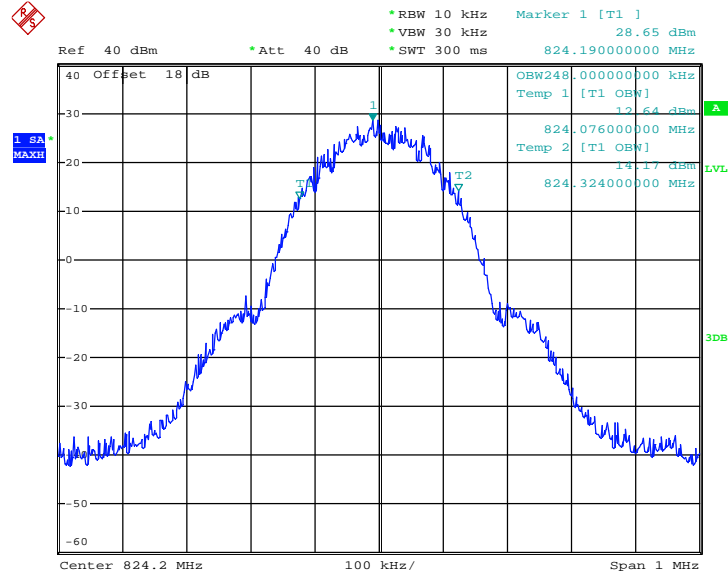

Date: 5.DEC.2013 14:05:59

26dB Bandwidth Plot on Channel 128 (824.2 MHz)

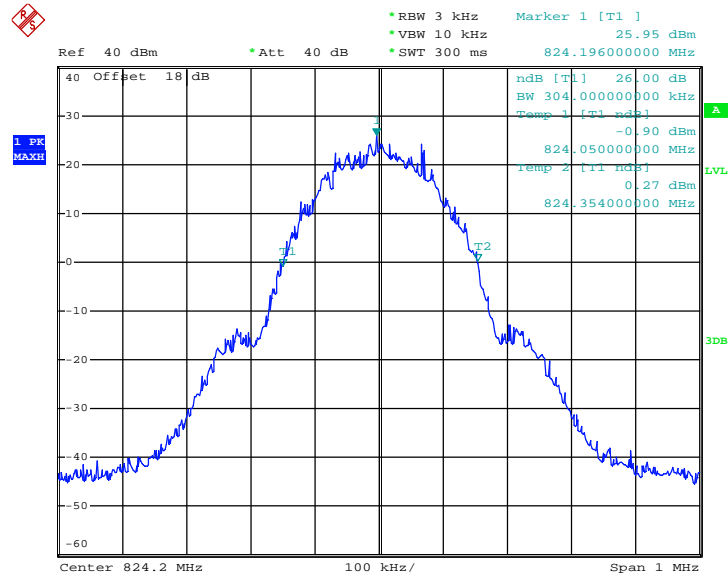

Date: 5.DEC.2013 13:26:29



99% Occupied Bandwidth Plot on Channel 189 (836.4 MHz)

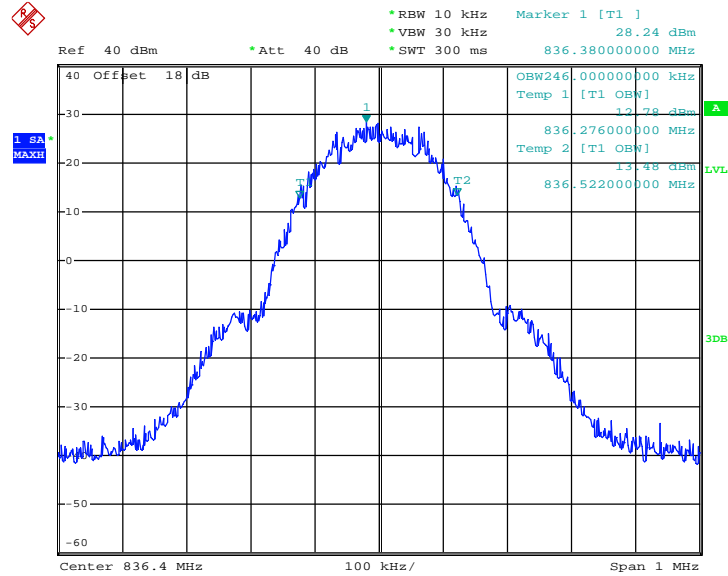

Date: 5.DEC.2013 14:04:17

26dB Bandwidth Plot on Channel 189 (836.4 MHz)

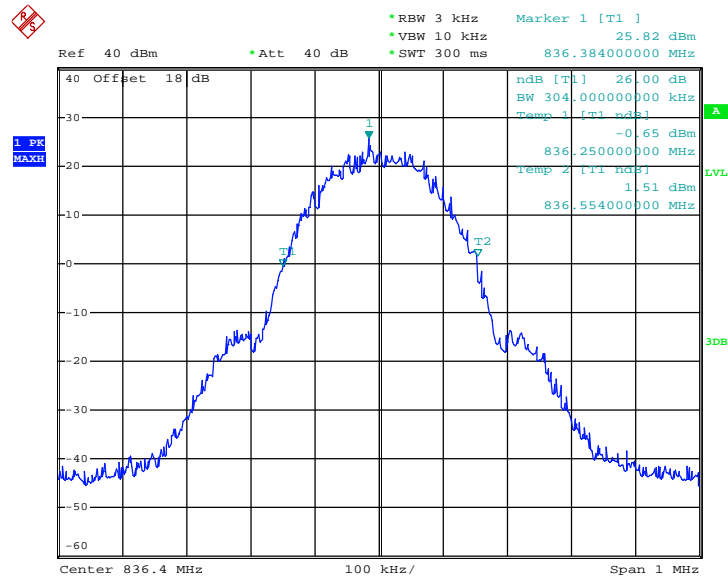

Date: 5.DEC.2013 13:27:17



99% Occupied Bandwidth Plot on Channel 251 (848.8 MHz)

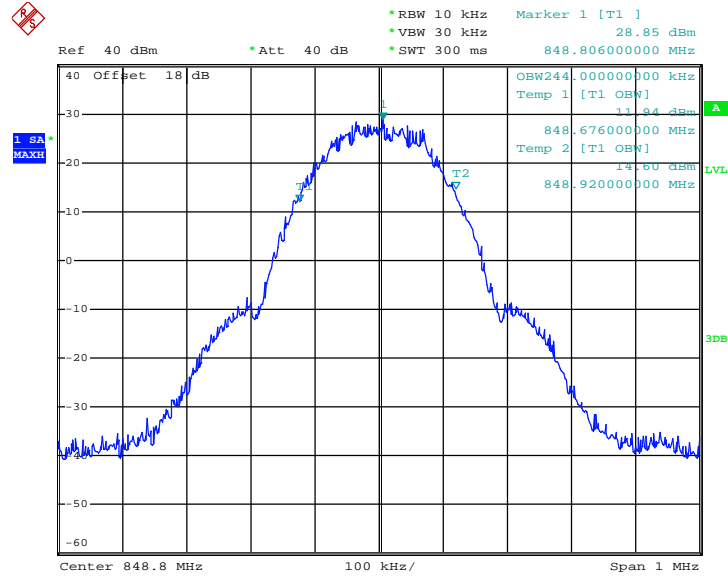

Date: 5.DEC.2013 14:02:35

26dB Bandwidth Plot on Channel 251 (848.8 MHz)

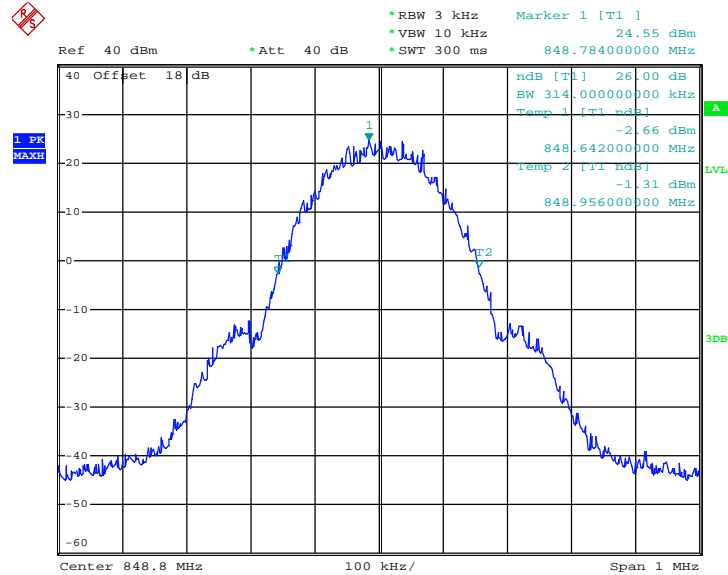

Date: 5.DEC.2013 13:59:41



| | | | |
|--------|----------|-------------|-----------------|
| Band : | GSM 1900 | Test Mode : | GSM Link (GMSK) |
|--------|----------|-------------|-----------------|

99% Occupied Bandwidth Plot on Channel 512 (1850.2 MHz)

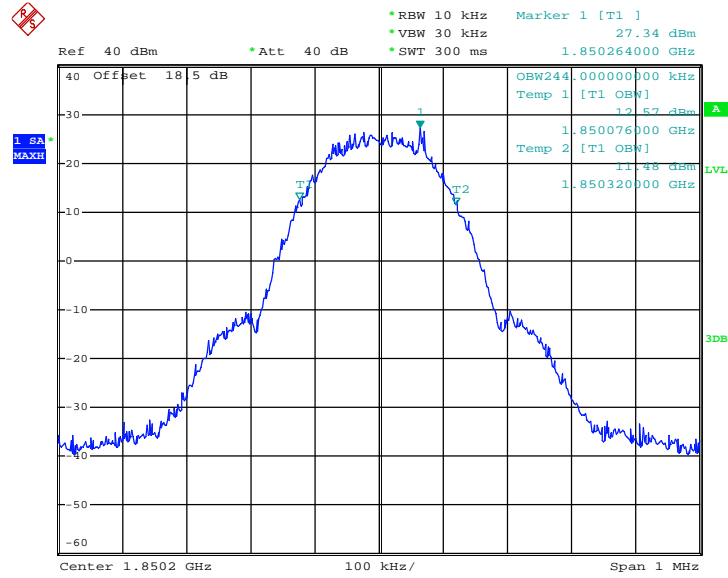

Date: 5.DEC.2013 14:40:22

26dB Bandwidth Plot on Channel 512 (1850.2 MHz)

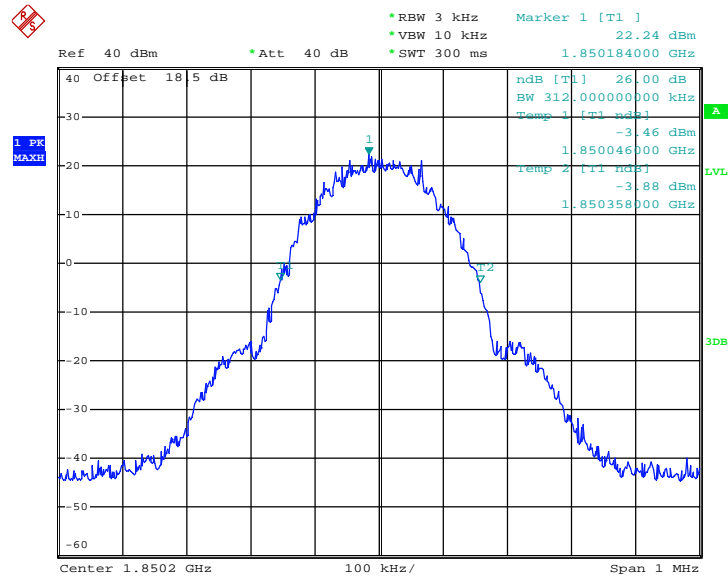

Date: 5.DEC.2013 14:16:17



99% Occupied Bandwidth Plot on Channel 661 (1880.0 MHz)

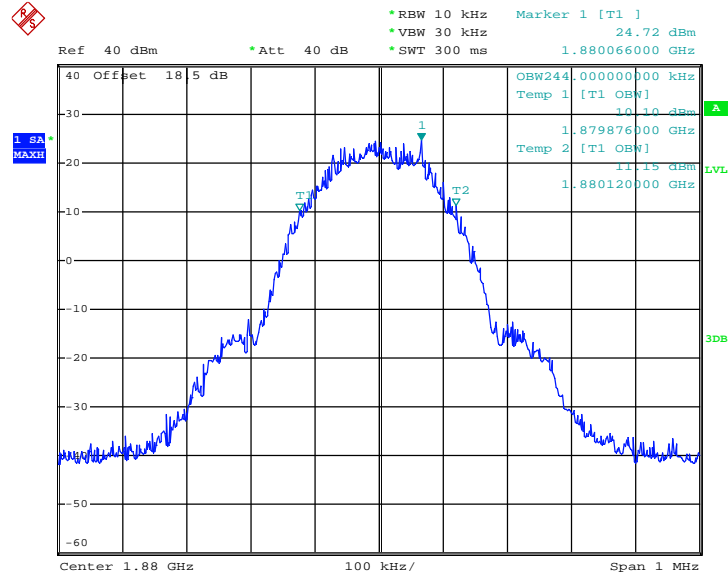

Date: 5.DEC.2013 14:32:09

26dB Bandwidth Plot on Channel 661 (1880.0 MHz)

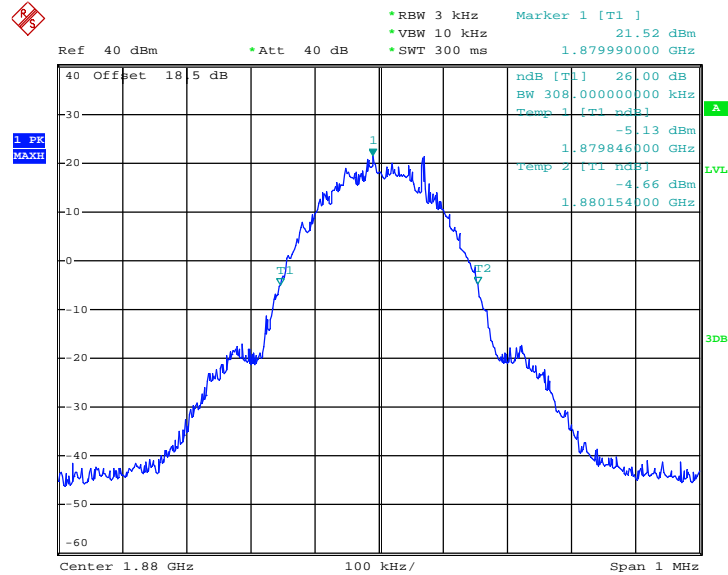

Date: 5.DEC.2013 14:15:06



99% Occupied Bandwidth Plot on Channel 810 (1909.8 MHz)

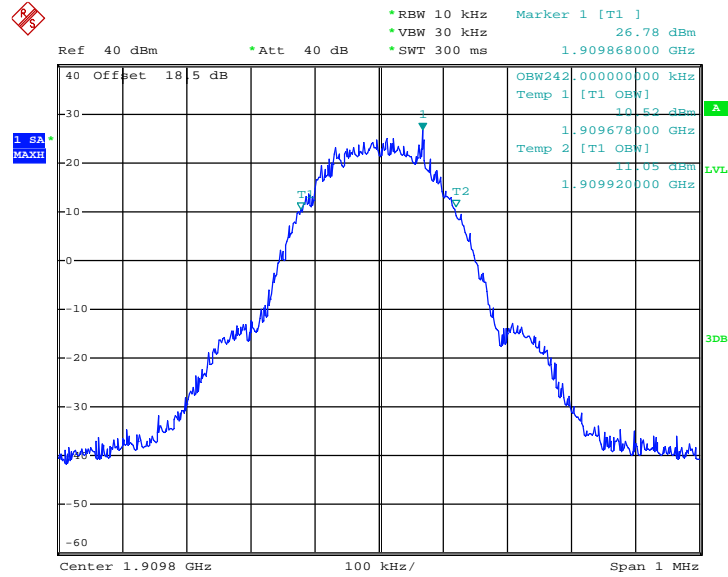

Date: 5.DEC.2013 14:30:39

26dB Bandwidth Plot on Channel 810 (1909.8 MHz)

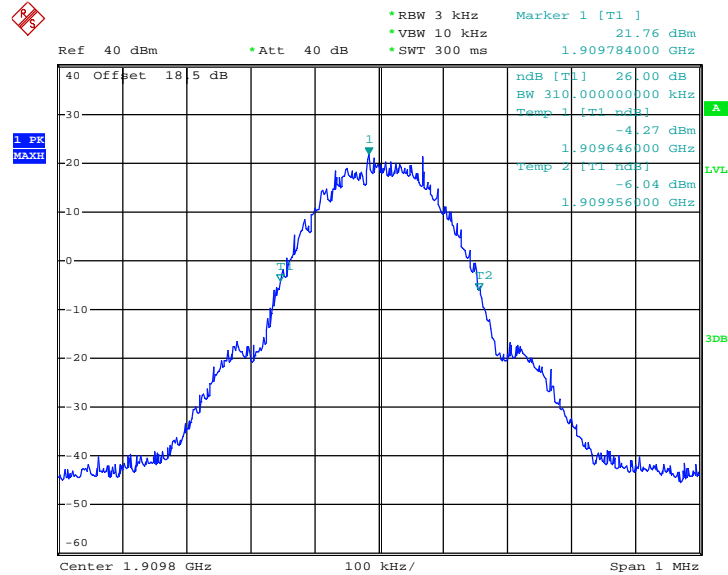

Date: 5.DEC.2013 14:14:03

3.5 Band Edge Measurement

3.5.1 Description of Band Edge Measurement

The power of any emission outside of the authorized operating frequency ranges must be lower than the transmitter power (P) by a factor of at least $43 + 10 \log (P)$ dB.

3.5.2 Measuring Instruments

The measuring equipment is listed in the section 4 of this test report.

3.5.3 Test Procedures

1. The EUT was connected to Spectrum Analyzer and Base Station via power divider.
2. The RF output of EUT was connected to the spectrum analyzer by RF cable and attenuator. The path loss was compensated to the results for each measurement.
3. The band edges of low and high channels for the highest RF powers were measured. Setting RBW as roughly $BW/100$.
4. The RF fundamental frequency should be excluded against the limit line in the operating frequency band.
5. The limit line is derived from $43 + 10\log(P)$ dB below the transmitter power P(Watts)

$$= P(W) - [43 + 10\log(P)] \text{ (dB)}$$

$$= [30 + 10\log(P)] \text{ (dBm)} - [43 + 10\log(P)] \text{ (dB)}$$

$$= -13\text{dBm}.$$

3.5.4 Test Setup

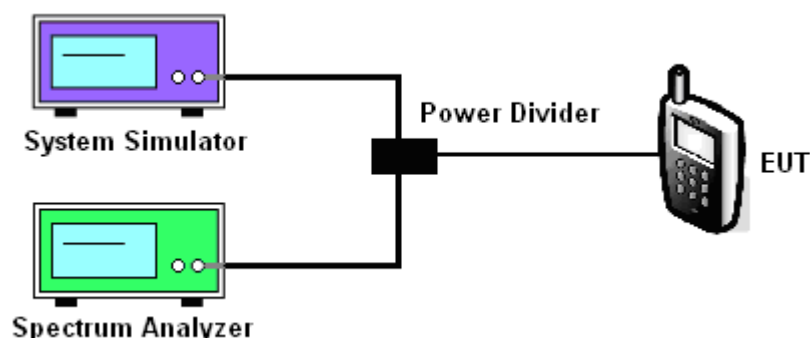

3.5.5 Test Result (Plots) of Conducted Band Edge

<SIM1>

| | | | |
|---------------------|-----------|--------------------------|-----------------|
| Band : | GSM850 | Test Mode : | GSM Link (GMSK) |
| Correction Factor : | 0.17dB | Maximum 26dB Bandwidth : | 0.312MHz |
| Band Edge : | -16.69dBm | Measurement Value : | -16.86dBm |

Lower Band Edge Plot on Channel 128 (824.2 MHz)

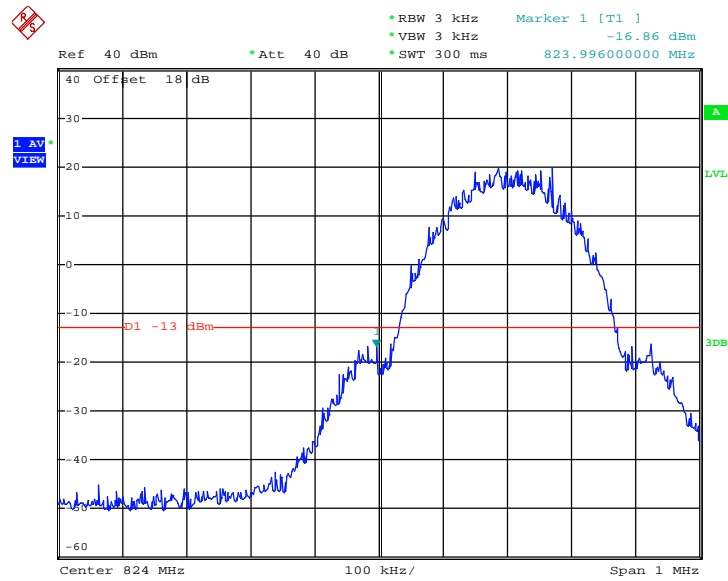

Date: 6.DEC.2013 14:18:59

1. Correction Factor(dB)= $10\log(1\% \text{ Emission BW/RBW})$
 2. Band Edge= Measurement Value + Correction Factor(dB)
- For example, $-16.86\text{dBm} + 0.17\text{dB} = -16.69\text{dBm}$

| | | | |
|---------------------|-----------|--------------------------|-----------------|
| Band : | GSM850 | Test Mode : | GSM Link (GMSK) |
| Correction Factor : | 0.17dB | Maximum 26dB Bandwidth : | 0.312MHz |
| Band Edge : | -16.75dBm | Measurement Value : | -16.92dBm |

Higher Band Edge Plot on Channel 251 (848.8 MHz)

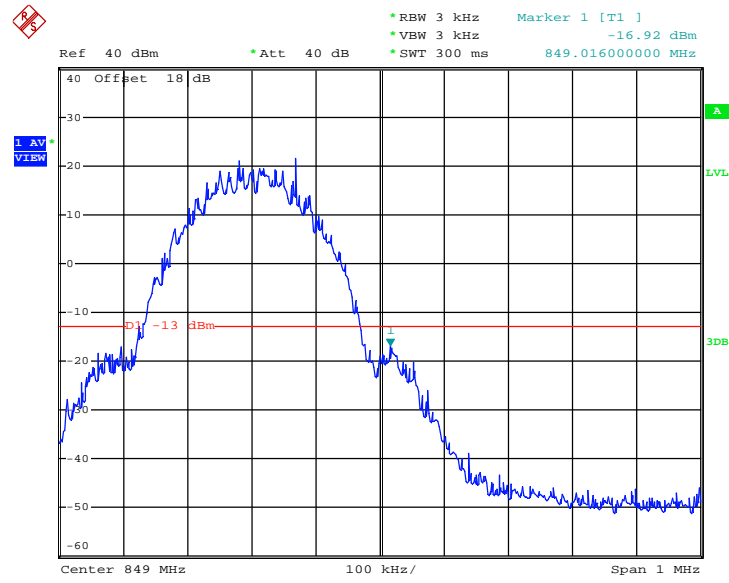

Date: 6.DEC.2013 14:20:04

1. Correction Factor(dB)= $10\log(1\% \text{ Emission BW/RBW})$
2. Band Edge= Measurement Value + Correction Factor(dB)



| | | | |
|---------------------|-----------|--------------------------|-----------------|
| Band : | GSM1900 | Test Mode : | GSM Link (GMSK) |
| Correction Factor : | 0.20dB | Maximum 26dB Bandwidth : | 0.314MHz |
| Band Edge : | -21.65dBm | Measurement Value : | -21.85dBm |

Lower Band Edge Plot on Channel 512 (1850.2 MHz)

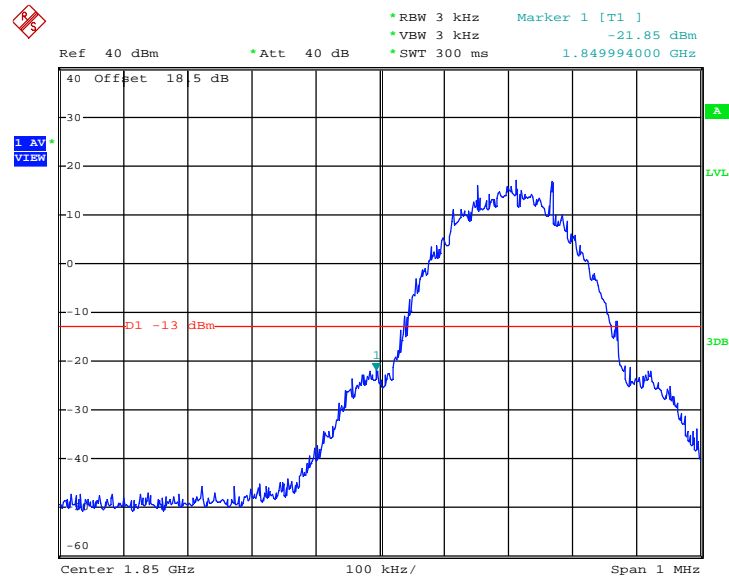

Date: 1.DEC.2013 15:21:40

1. Correction Factor(dB)= 10log(1% Emission BW/RBW)
2. Band Edge= Measurement Value + Correction Factor(dB)

| | | | |
|---------------------|-----------|--------------------------|-----------------|
| Band : | GSM1900 | Test Mode : | GSM Link (GMSK) |
| Correction Factor : | 0.20dB | Maximum 26dB Bandwidth : | 0.314MHz |
| Band Edge : | -19.32dBm | Measurement Value : | -19.52dBm |

Higher Band Edge Plot on Channel 810 (1909.8 MHz)

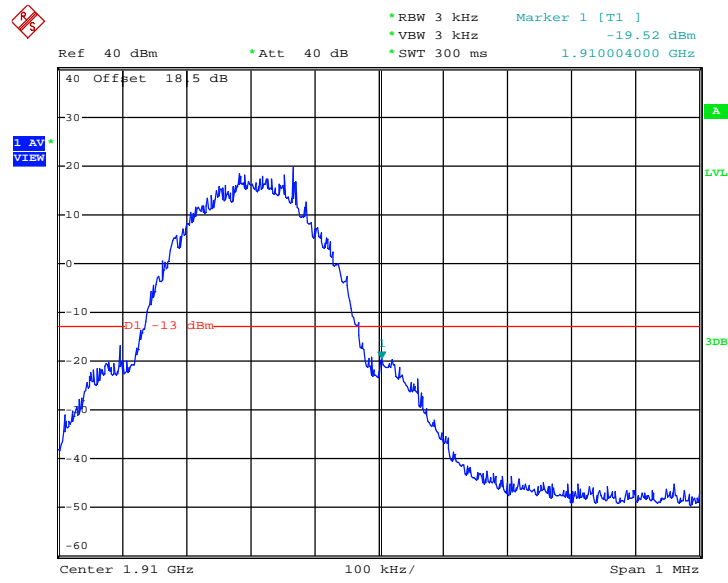

Date: 1.DEC.2013 15:25:17

1. Correction Factor(dB)= $10\log(1\% \text{ Emission BW/RBW})$
2. Band Edge= Measurement Value + Correction Factor(dB)



<SIM2>

| | | | |
|---------------------|-----------|--------------------------|-----------------|
| Band : | GSM850 | Test Mode : | GSM Link (GMSK) |
| Correction Factor : | 0.20dB | Maximum 26dB Bandwidth : | 0.314MHz |
| Band Edge : | -18.83dBm | Measurement Value : | -19.03dBm |

Lower Band Edge Plot on Channel 128 (824.2 MHz)

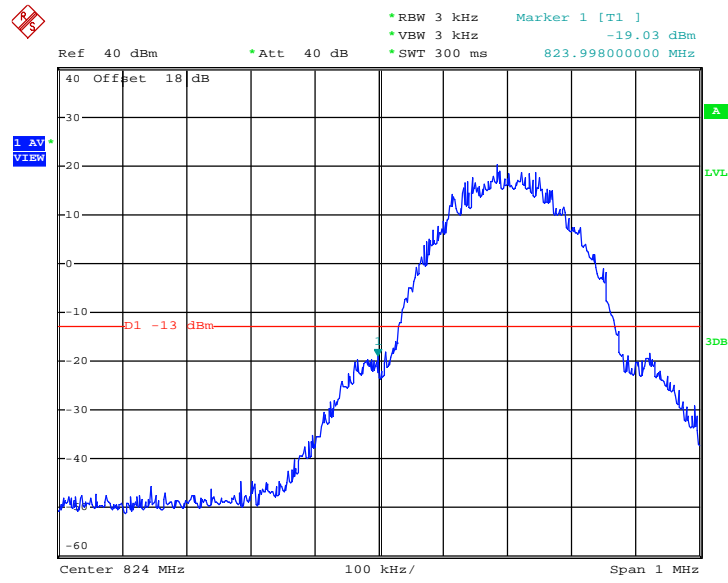

Date: 5.DEC.2013 14:07:43

1. Correction Factor(dB)= 10log(1% Emission BW/RBW)
2. Band Edge= Measurement Value + Correction Factor(dB)



| | | | |
|---------------------|-----------|--------------------------|-----------------|
| Band : | GSM850 | Test Mode : | GSM Link (GMSK) |
| Correction Factor : | 0.20dB | Maximum 26dB Bandwidth : | 0.314MHz |
| Band Edge : | -17.25dBm | Measurement Value : | -17.45dBm |

Higher Band Edge Plot on Channel 251 (848.8 MHz)

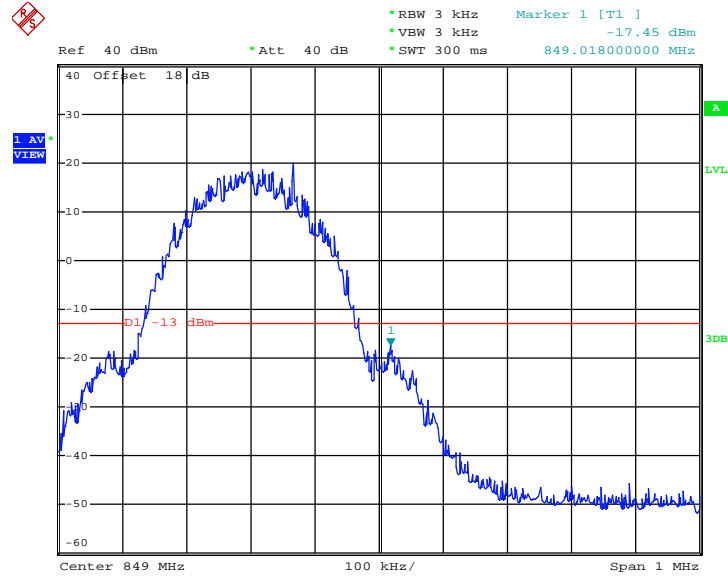

Date: 5.DEC.2013 14:08:35

1. Correction Factor(dB)= 10log(1% Emission BW/RBW)
2. Band Edge= Measurement Value + Correction Factor(dB)



| | | | |
|---------------------|-----------|--------------------------|-----------------|
| Band : | GSM1900 | Test Mode : | GSM Link (GMSK) |
| Correction Factor : | 0.17dB | Maximum 26dB Bandwidth : | 0.312MHz |
| Band Edge : | -20.08dBm | Measurement Value : | -20.25dBm |

Lower Band Edge Plot on Channel 512 (1850.2 MHz)

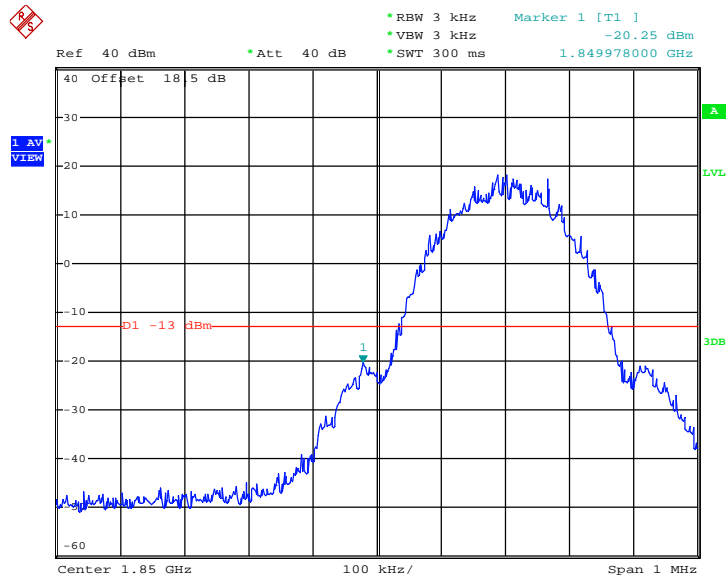

Date: 5.DEC.2013 14:11:08

1. Correction Factor(dB)= $10\log(1\% \text{ Emission BW/RBW})$
2. Band Edge= Measurement Value + Correction Factor(dB)



| | | | |
|---------------------|-----------|--------------------------|-----------------|
| Band : | GSM1900 | Test Mode : | GSM Link (GMSK) |
| Correction Factor : | 0.17dB | Maximum 26dB Bandwidth : | 0.312MHz |
| Band Edge : | -20.02dBm | Measurement Value : | -20.19dBm |

Higher Band Edge Plot on Channel 810 (1909.8 MHz)

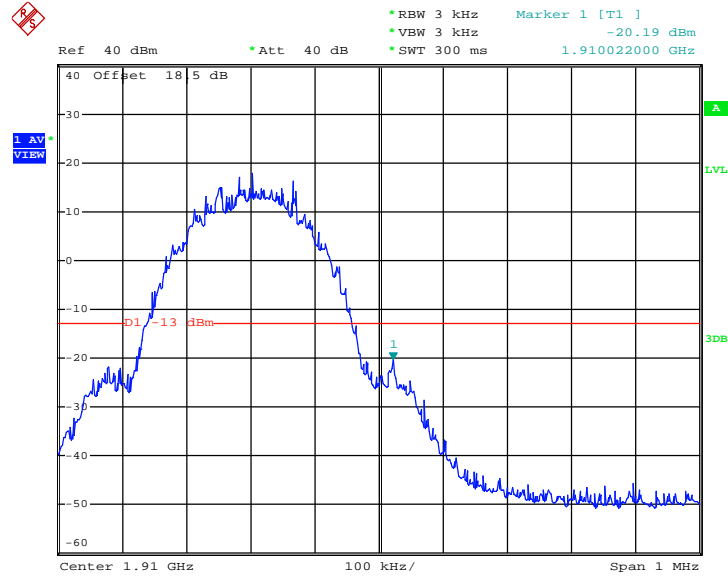

Date: 5.DEC.2013 14:12:35

1. Correction Factor(dB)= $10\log(1\% \text{ Emission BW/RBW})$
2. Band Edge= Measurement Value + Correction Factor(dB)

3.6 Conducted Spurious Emission Measurement

3.6.1 Description of Conducted Spurious Emission Measurement

The power of any emission outside of the authorized operating frequency ranges must be lower than the transmitter power (P) by a factor of at least $43 + 10 \log (P)$ dB.

It is measured by means of a calibrated spectrum analyzer and scanned from 30 MHz up to a frequency including its 10th harmonic.

3.6.2 Measuring Instruments

The measuring equipment is listed in the section 4 of this test report.

3.6.3 Test Procedures

1. The EUT was connected to spectrum analyzer and base station via power divider.
2. The RF output of EUT was connected to the spectrum analyzer by RF cable and attenuator. The path loss was compensated to the results for each measurement.
3. The middle channel for the highest RF power within the transmitting frequency was measured.
4. The conducted spurious emission for the whole frequency range was taken.
5. The RF fundamental frequency should be excluded against the limit line in the operating frequency band.
6. The limit line is derived from $43 + 10\log(P)$ dB below the transmitter power P(Watts)

$$= P(W) - [43 + 10\log(P)] \text{ (dB)}$$

$$= [30 + 10\log(P)] \text{ (dBm)} - [43 + 10\log(P)] \text{ (dB)}$$

$$= -13\text{dBm}$$

3.6.4 Test Setup

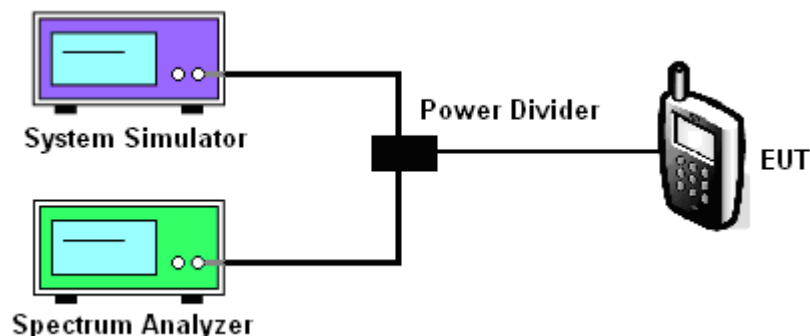

3.6.5 Test Result (Plots) of Conducted Spurious Emission

<SIM1>

| | | | |
|-------------|-----------------|-------------|-----------|
| Band : | GSM850 | Channel : | CH128 |
| Test Mode : | GSM Link (GMSK) | Frequency : | 824.2 MHz |

Conducted Spurious Emission Plot between 30MHz ~ 1GHz

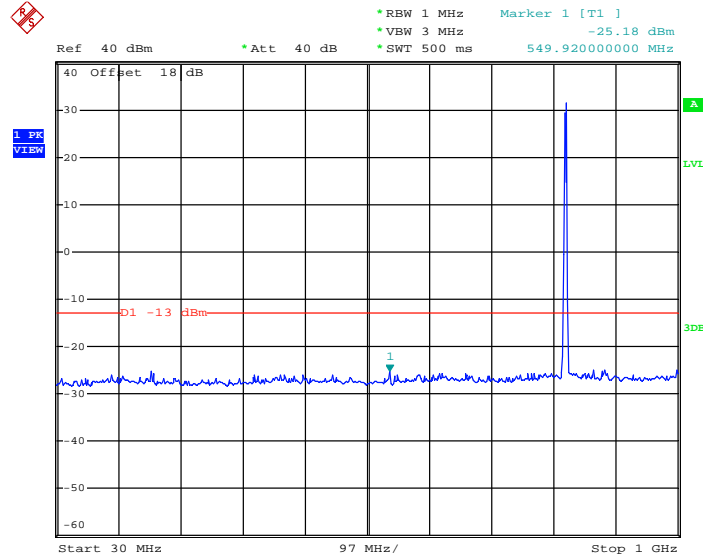

Date: 5.DEC.2013 10:41:17

Conducted Spurious Emission Plot between 1GHz ~ 3GHz

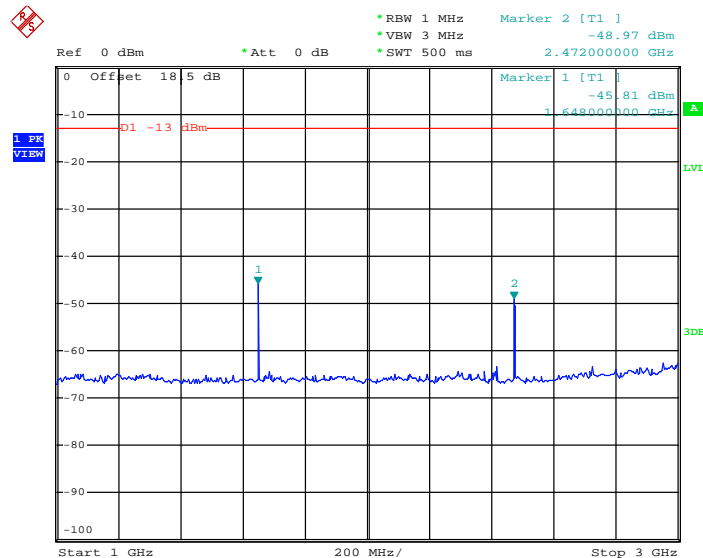

Date: 5.DEC.2013 10:45:09



Conducted Spurious Emission Plot between 3GHz ~ 7GHz

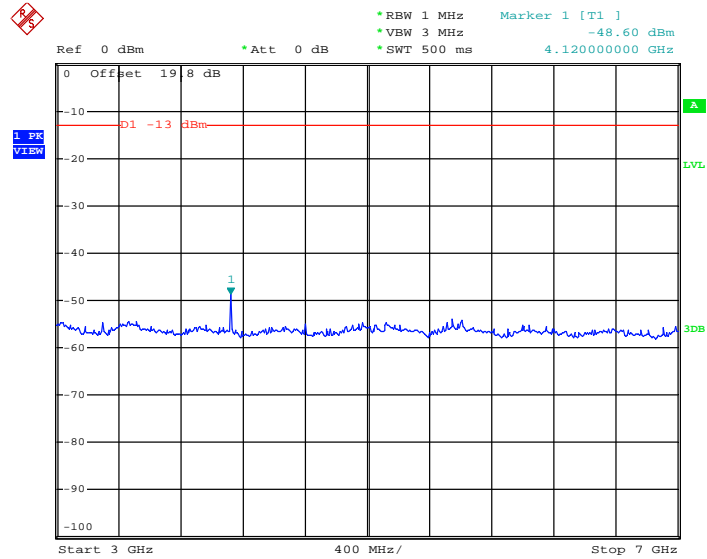

Date: 5.DEC.2013 10:46:02

Conducted Spurious Emission Plot between 7GHz ~ 9GHz

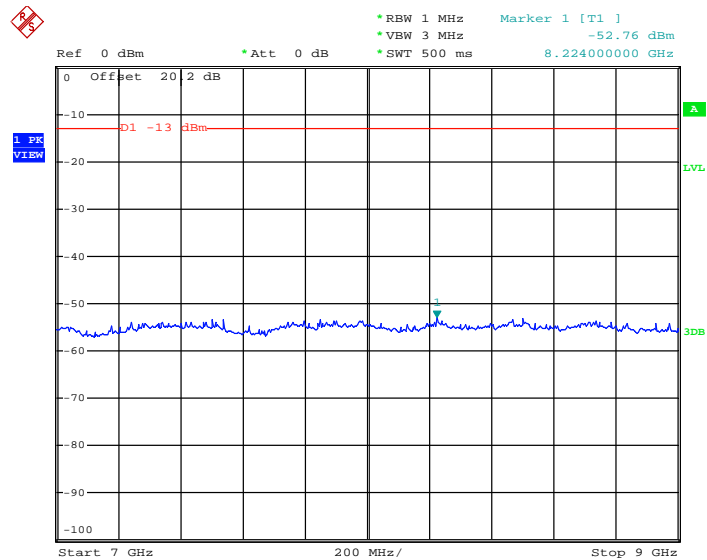

Date: 5.DEC.2013 10:53:14



| | | | |
|-------------|-----------------|-------------|-----------|
| Band : | GSM850 | Channel : | CH189 |
| Test Mode : | GSM Link (GMSK) | Frequency : | 836.4 MHz |

Conducted Spurious Emission Plot between 30MHz ~ 1GHz

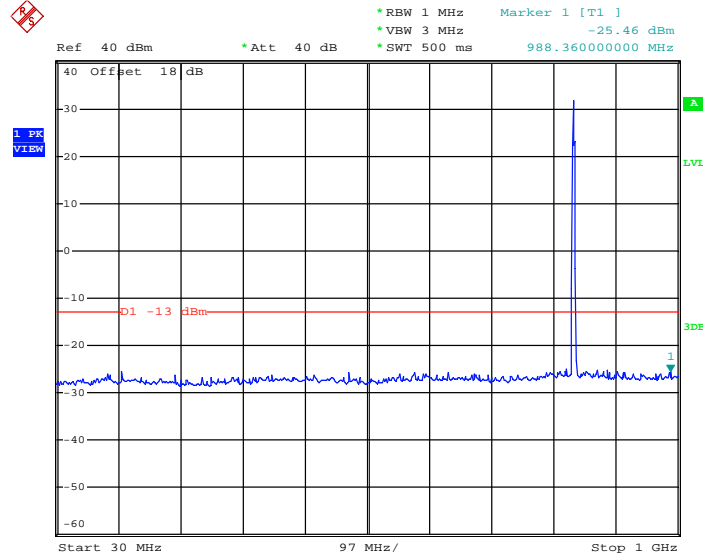

Date: 5.DEC.2013 10:40:39

Conducted Spurious Emission Plot between 1GHz ~ 3GHz

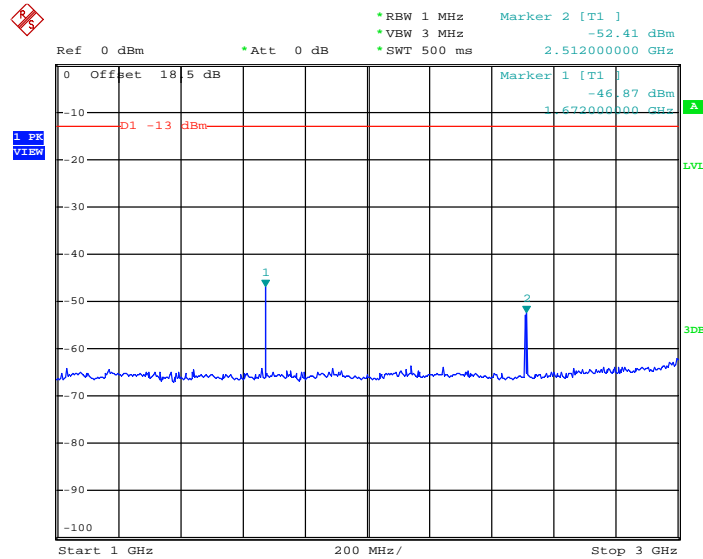

Date: 5.DEC.2013 10:44:26



Conducted Spurious Emission Plot between 3GHz ~ 7GHz

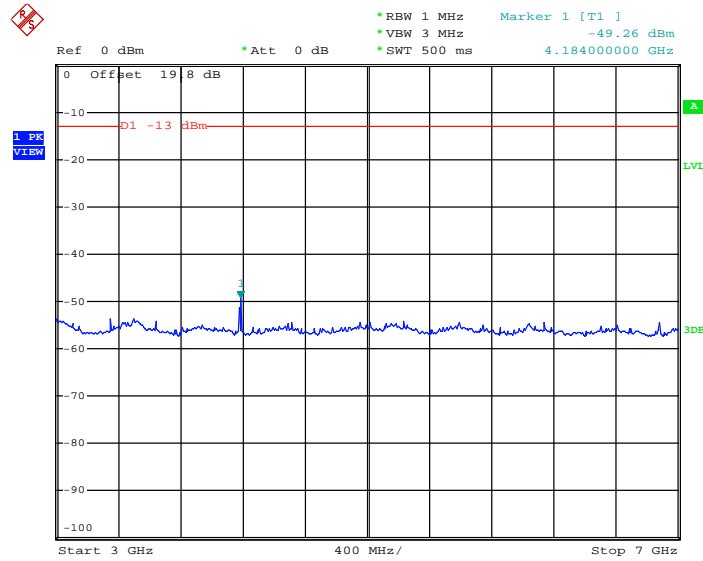

Date: 5.DEC.2013 10:47:59

Conducted Spurious Emission Plot between 7GHz ~ 9GHz

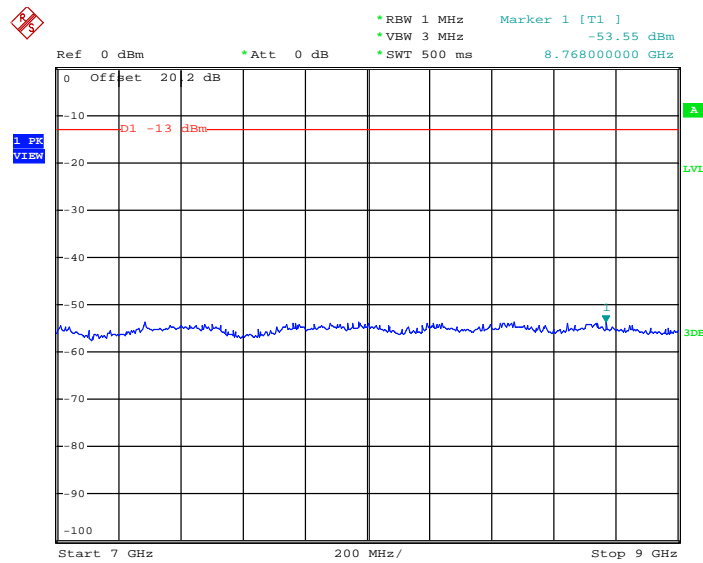

Date: 5.DEC.2013 10:51:44



| | | | |
|-------------|-----------------|-------------|-----------|
| Band : | GSM850 | Channel : | CH251 |
| Test Mode : | GSM Link (GMSK) | Frequency : | 848.8 MHz |

Conducted Spurious Emission Plot between 30MHz ~ 1GHz

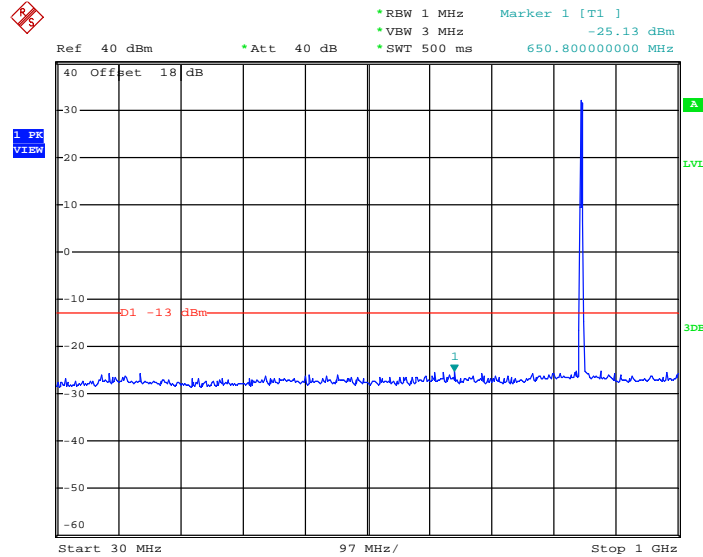

Date: 5.DEC.2013 10:41:46

Conducted Spurious Emission Plot between 1GHz ~ 3GHz

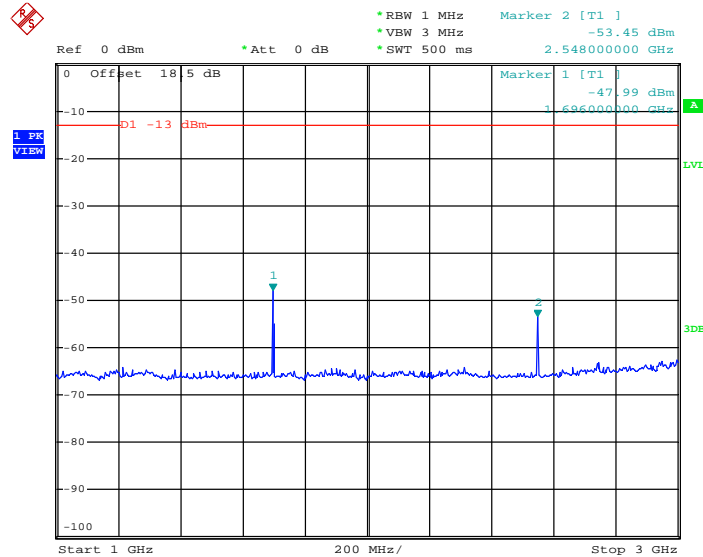

Date: 5.DEC.2013 10:43:38



Conducted Spurious Emission Plot between 3GHz ~ 7GHz

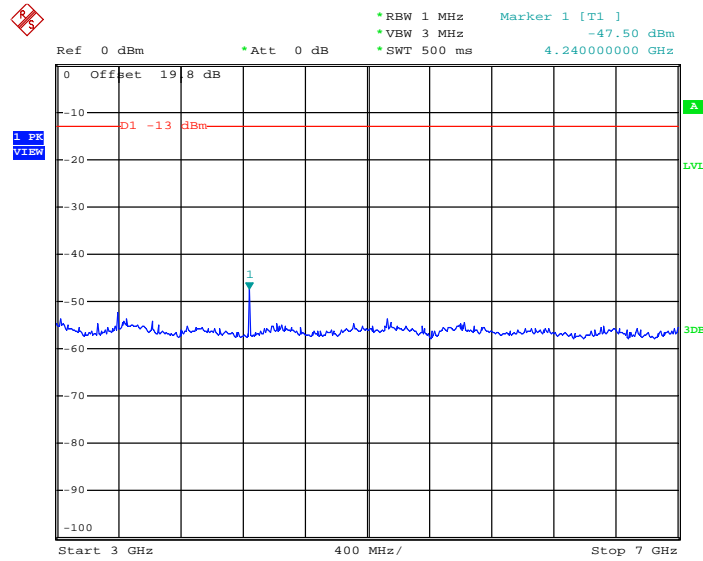

Date: 5.DEC.2013 10:49:00

Conducted Spurious Emission Plot between 7GHz ~ 9GHz

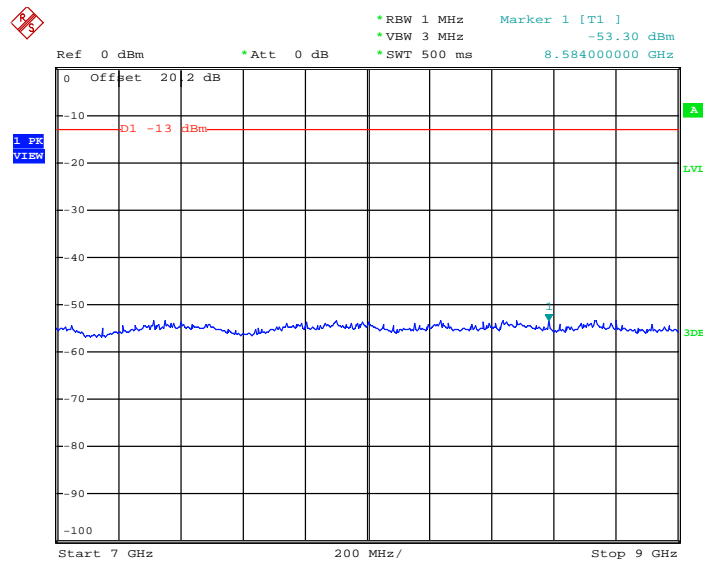

Date: 5.DEC.2013 10:50:50



| | | | |
|-------------|-----------------|-------------|------------|
| Band : | GSM1900 | Channel : | CH512 |
| Test Mode : | GSM Link (GMSK) | Frequency : | 1850.2 MHz |

Conducted Spurious Emission Plot between 30MHz ~ 1GHz

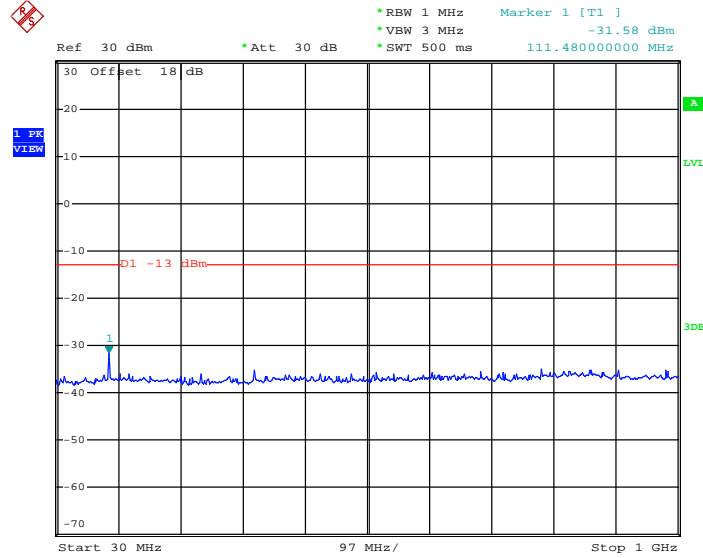

Date: 5.DEC.2013 11:27:57

Conducted Spurious Emission Plot between 1GHz ~ 3GHz

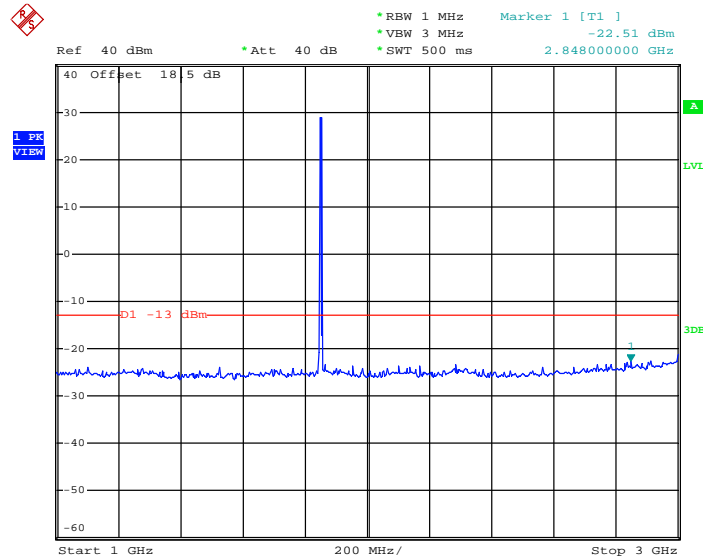

Date: 5.DEC.2013 12:14:22



Conducted Spurious Emission Plot between 3GHz ~ 7GHz

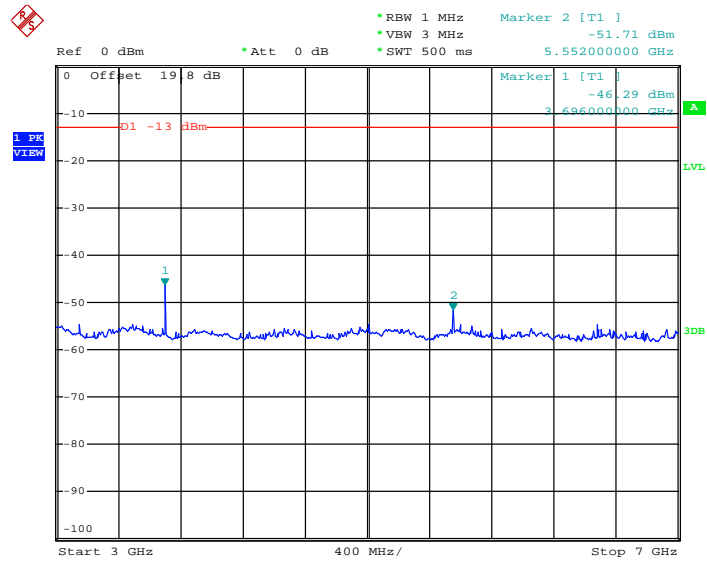

Date: 5.DEC.2013 10:56:51

Conducted Spurious Emission Plot between 7GHz ~ 13.6GHz

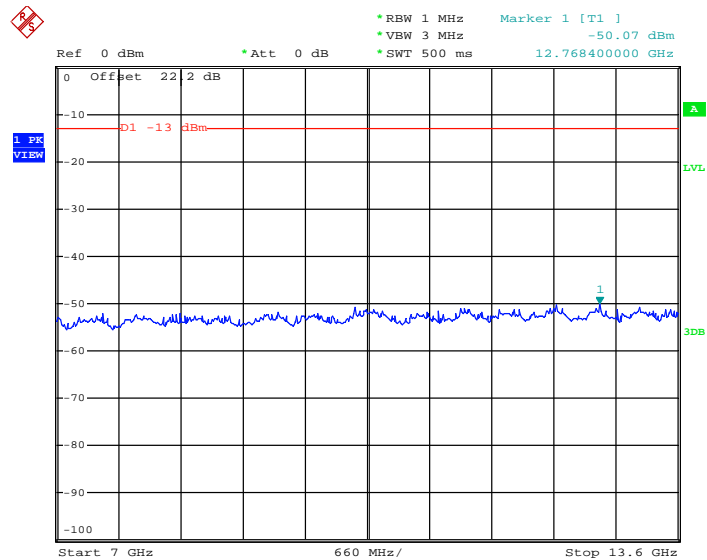

Date: 5.DEC.2013 10:59:31



Conducted Spurious Emission Plot between 13.6GHz ~ 19.1GHz

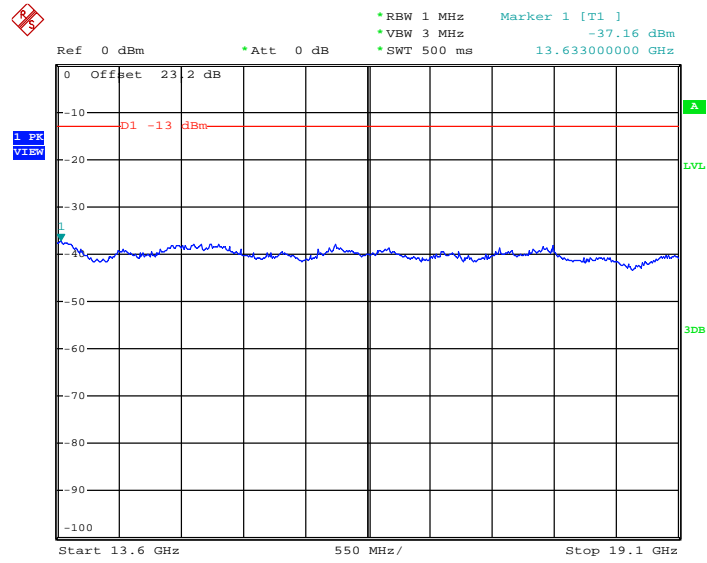

Date: 5.DEC.2013 11:21:55



| | | | |
|-------------|-----------------|-------------|------------|
| Band : | GSM1900 | Channel : | CH661 |
| Test Mode : | GSM Link (GMSK) | Frequency : | 1880.0 MHz |

Conducted Spurious Emission Plot between 30MHz ~ 1GHz

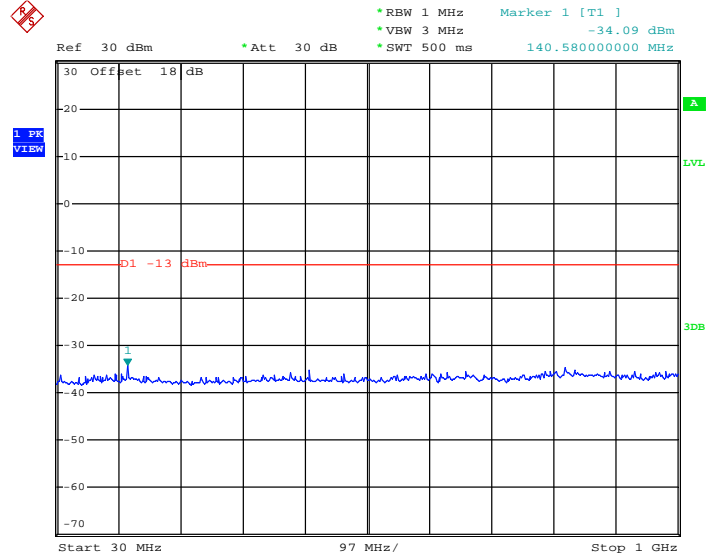

Date: 5.DEC.2013 11:27:16

Conducted Spurious Emission Plot between 1GHz ~ 3GHz

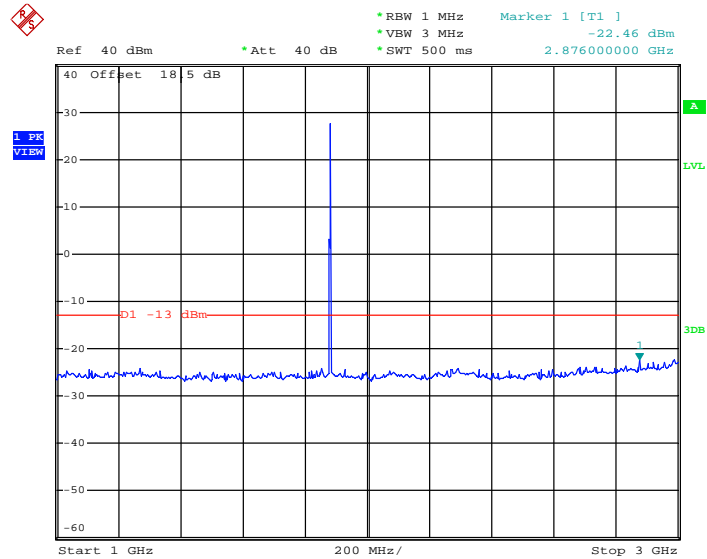

Date: 5.DEC.2013 12:11:55



Conducted Spurious Emission Plot between 3GHz ~ 7GHz

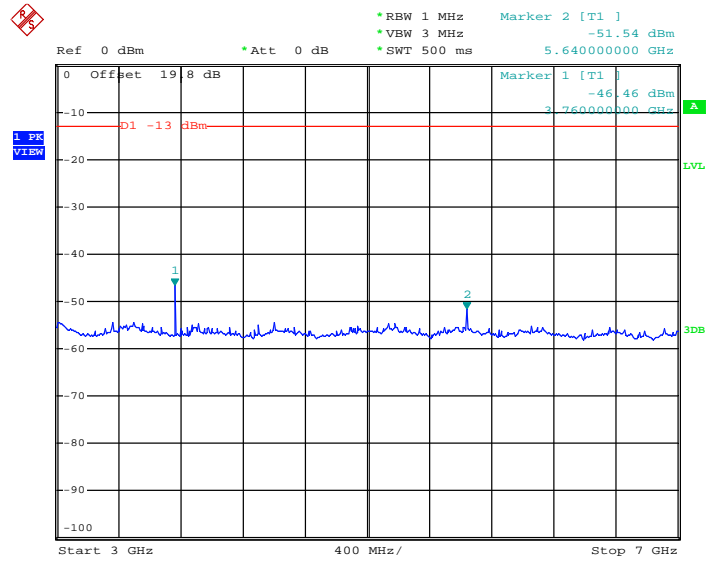

Date: 5.DEC.2013 10:56:15

Conducted Emission Plot between 7GHz ~ 13.6GHz

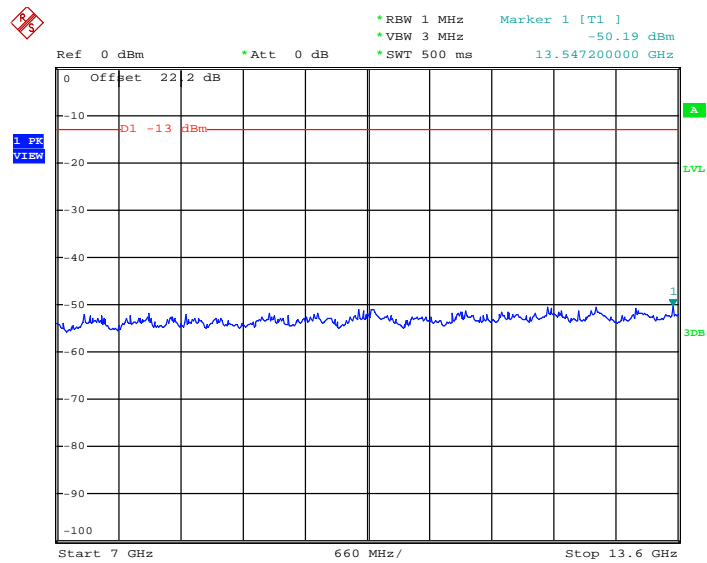

Date: 5.DEC.2013 10:59:01



Conducted Spurious Emission Plot between 13.6GHz ~ 19.1GHz

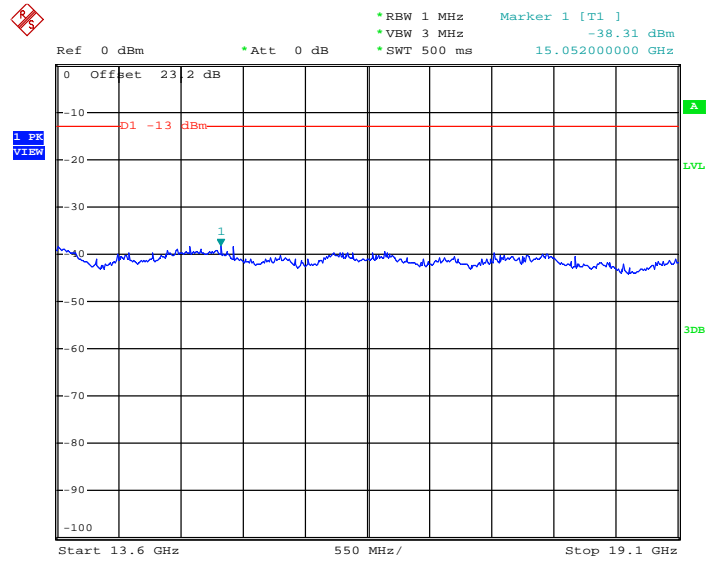

Date: 5.DEC.2013 11:22:38



| | | | |
|-------------|-----------------|-------------|------------|
| Band : | GSM1900 | Channel : | CH810 |
| Test Mode : | GSM Link (GMSK) | Frequency : | 1909.8 MHz |

Conducted Spurious Emission Plot between 30MHz ~ 1GHz

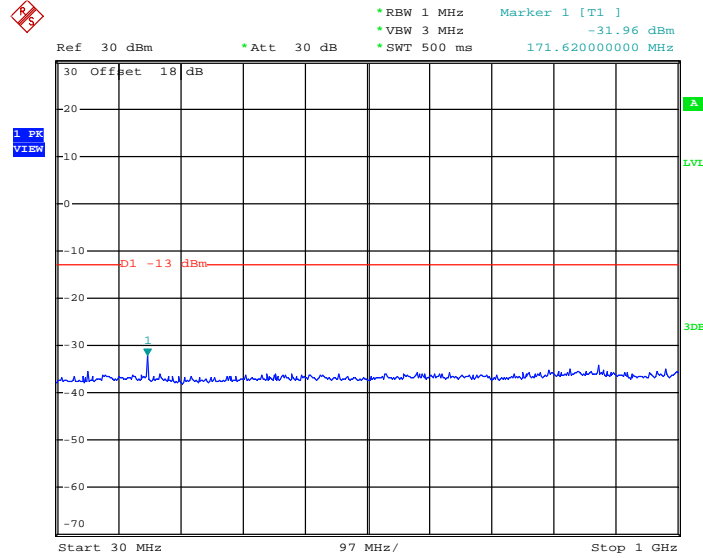

Date: 5.DEC.2013 11:26:35

Conducted Spurious Emission Plot between 1GHz ~ 3GHz

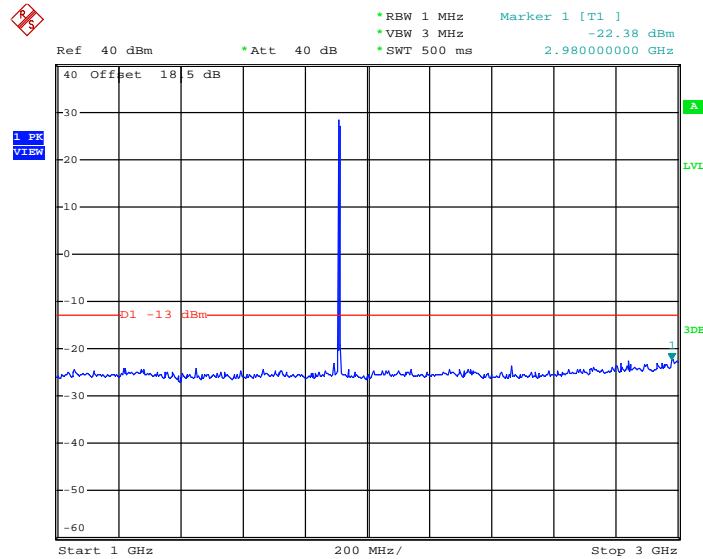

Date: 5.DEC.2013 12:12:59



Conducted Spurious Emission Plot between 3GHz ~ 7GHz

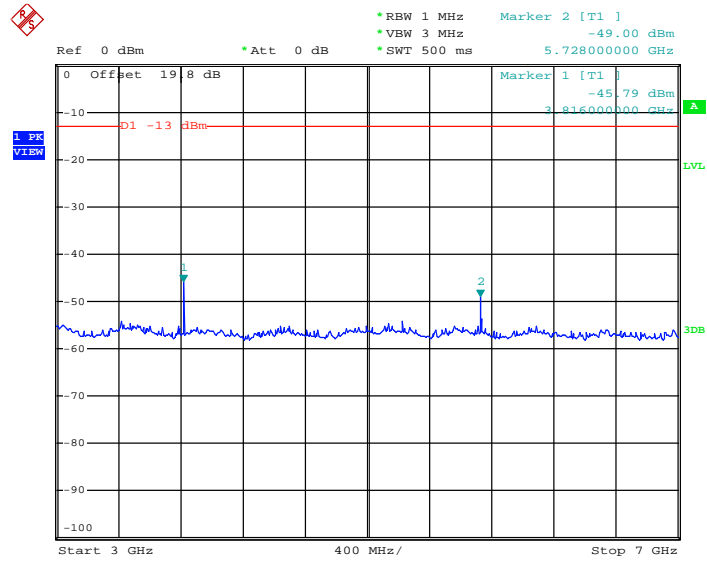

Date: 5.DEC.2013 10:57:28

Conducted Spurious Emission Plot between 7GHz ~ 13.6GHz

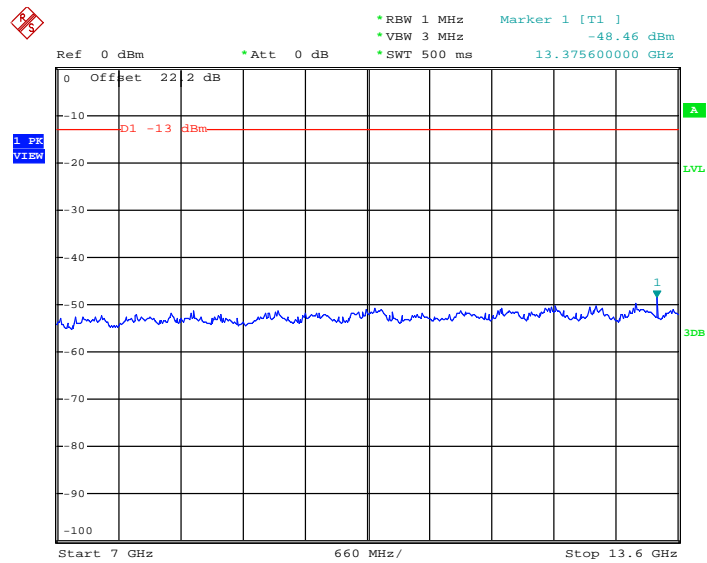

Date: 5.DEC.2013 10:58:39



Conducted Spurious Emission Plot between 13.6GHz ~ 19.1GHz

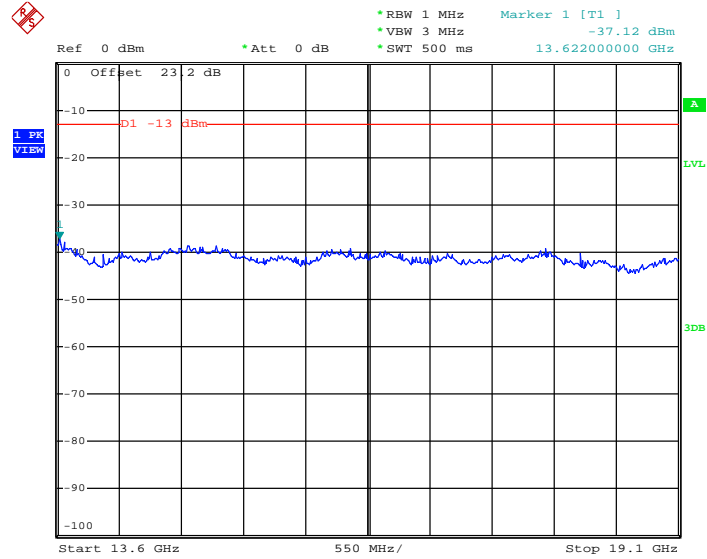

Date: 5.DEC.2013 11:23:25



<SIM2>

| | | | |
|-------------|-----------------|-------------|-----------|
| Band : | GSM850 | Channel : | CH128 |
| Test Mode : | GSM Link (GMSK) | Frequency : | 824.2 MHz |

Conducted Spurious Emission Plot between 30MHz ~ 1GHz

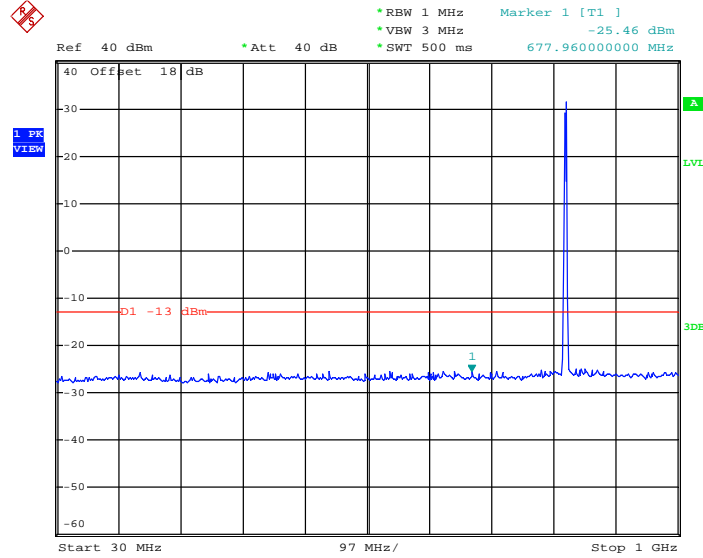

Date: 5.DEC.2013 13:24:39

Conducted Spurious Emission Plot between 1GHz ~ 3GHz

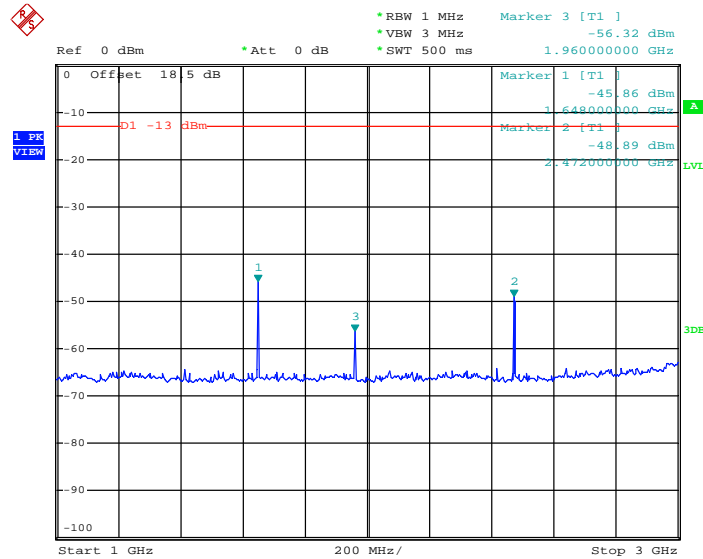

Date: 5.DEC.2013 13:16:41



Conducted Spurious Emission Plot between 3GHz ~ 7GHz

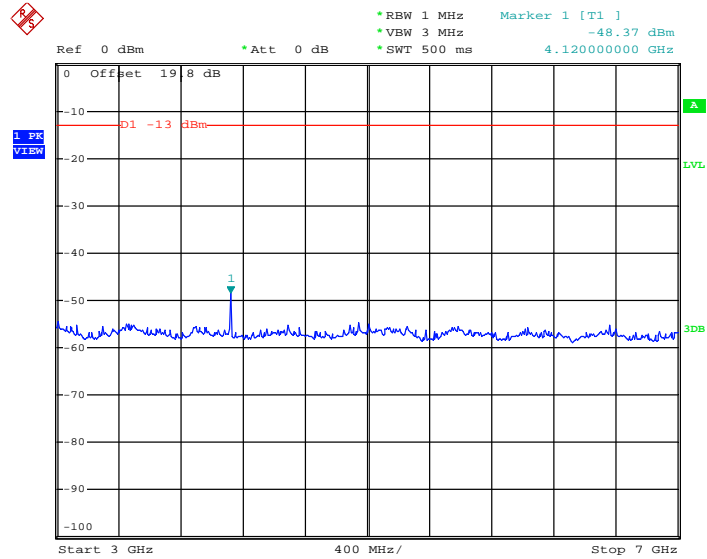

Date: 5.DEC.2013 13:19:09

Conducted Spurious Emission Plot between 7GHz ~ 9GHz

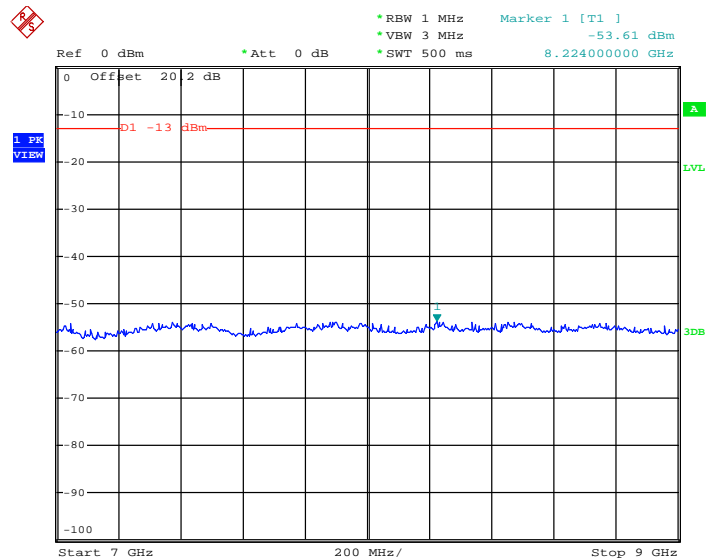

Date: 5.DEC.2013 13:20:20



| | | | |
|-------------|-----------------|-------------|-----------|
| Band : | GSM850 | Channel : | CH189 |
| Test Mode : | GSM Link (GMSK) | Frequency : | 836.4 MHz |

Conducted Spurious Emission Plot between 30MHz ~ 1GHz

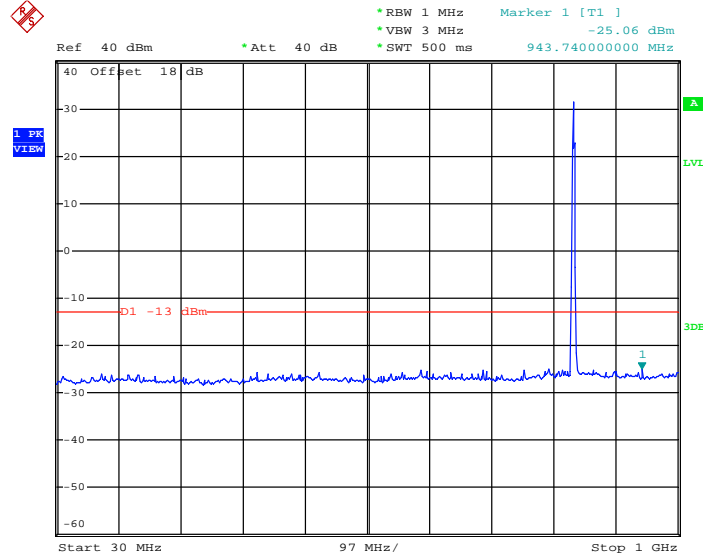

Date: 5.DEC.2013 13:23:26

Conducted Spurious Emission Plot between 1GHz ~ 3GHz

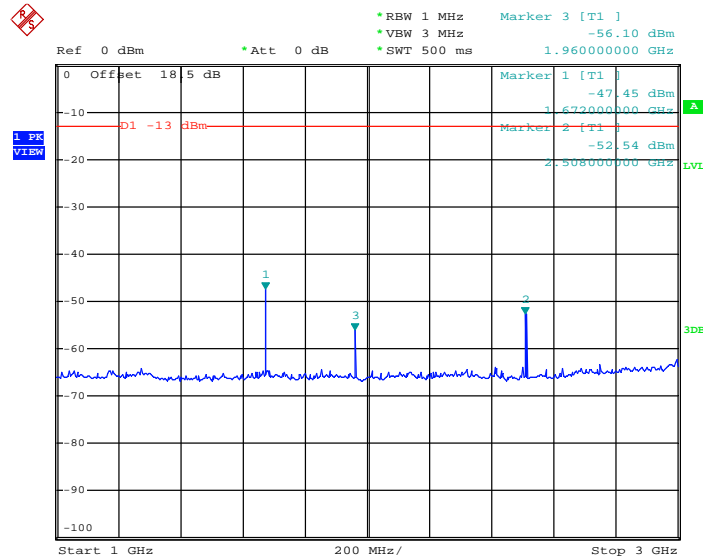

Date: 5.DEC.2013 13:16:12



Conducted Spurious Emission Plot between 3GHz ~ 7GHz

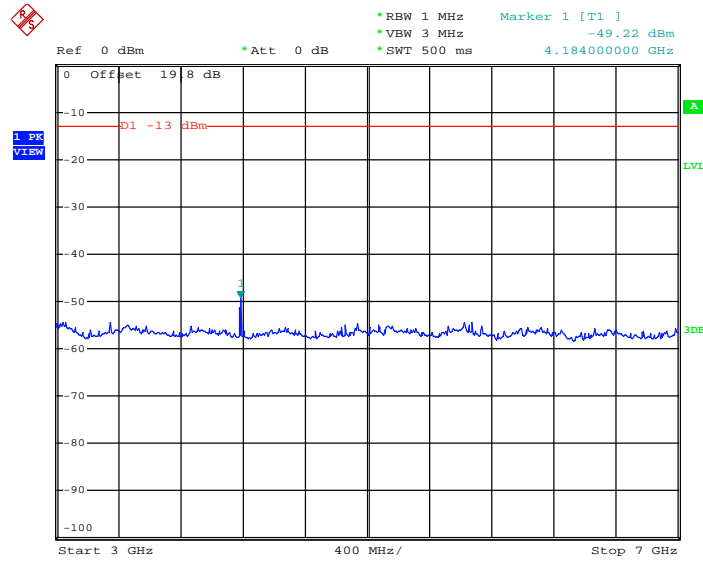

Date: 5.DEC.2013 13:18:48

Conducted Spurious Emission Plot between 7GHz ~ 9GHz

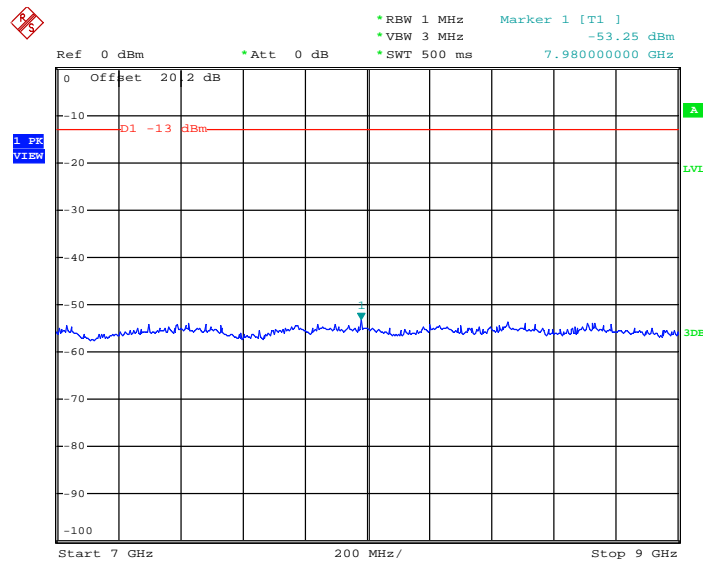

Date: 5.DEC.2013 13:20:54



| | | | |
|-------------|-----------------|-------------|-----------|
| Band : | GSM850 | Channel : | CH251 |
| Test Mode : | GSM Link (GMSK) | Frequency : | 848.8 MHz |

Conducted Spurious Emission Plot between 30MHz ~ 1GHz

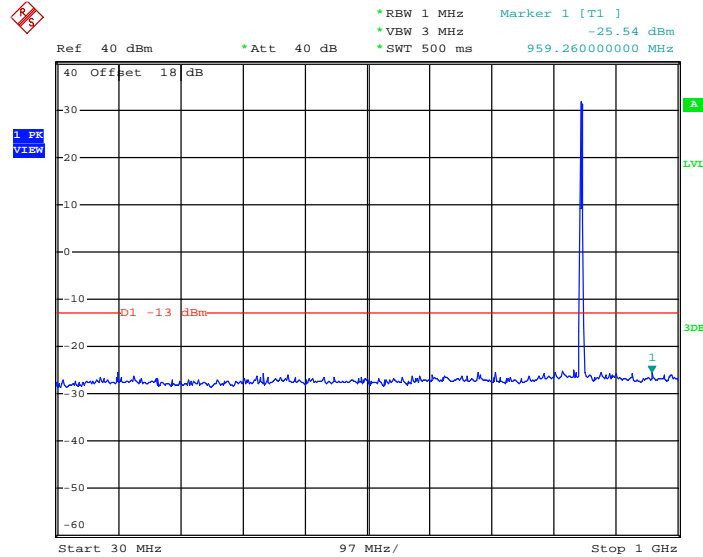

Date: 5.DEC.2013 13:22:37

Conducted Spurious Emission Plot between 1GHz ~ 3GHz

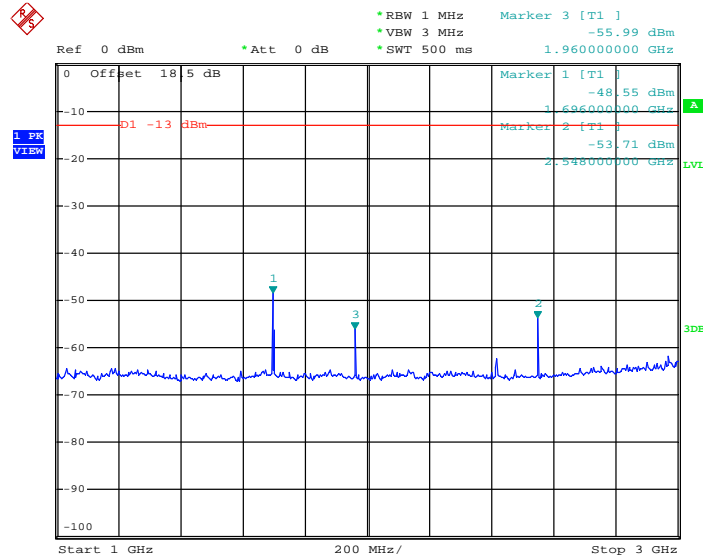

Date: 5.DEC.2013 13:17:24



Conducted Spurious Emission Plot between 3GHz ~ 7GHz

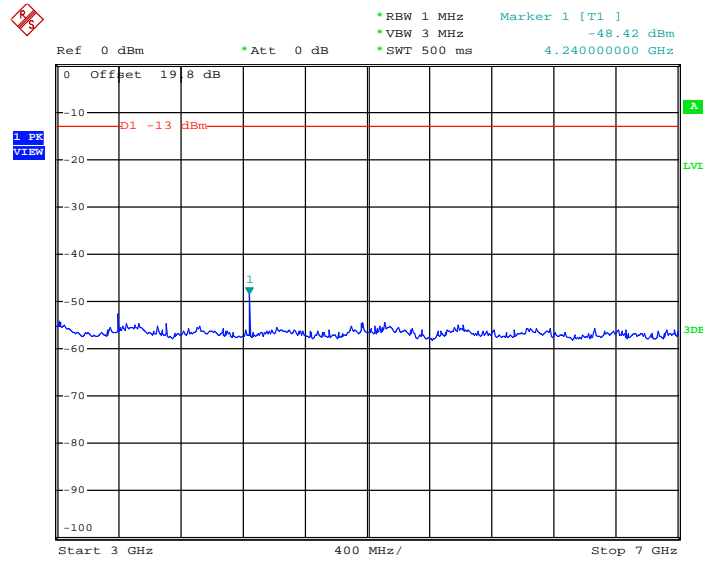

Date: 5.DEC.2013 13:18:14

Conducted Spurious Emission Plot between 7GHz ~ 9GHz

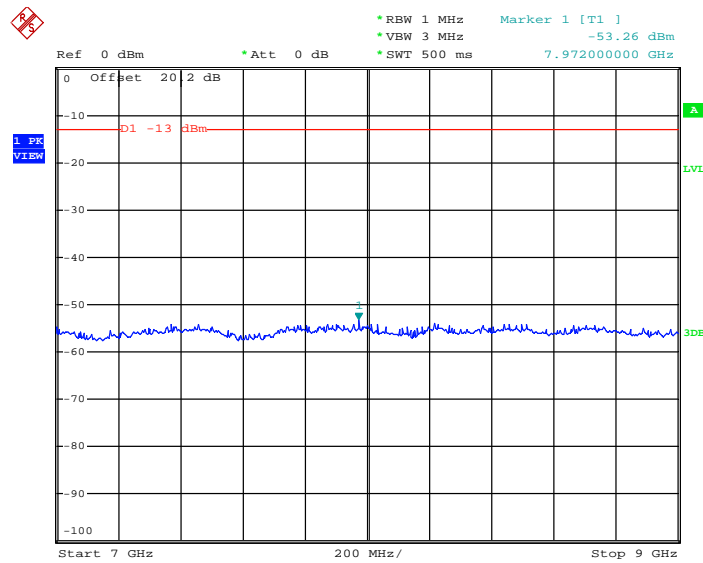

Date: 5.DEC.2013 13:21:21



| | | | |
|-------------|-----------------|-------------|------------|
| Band : | GSM1900 | Channel : | CH512 |
| Test Mode : | GSM Link (GMSK) | Frequency : | 1850.2 MHz |

Conducted Spurious Emission Plot between 30MHz ~ 1GHz

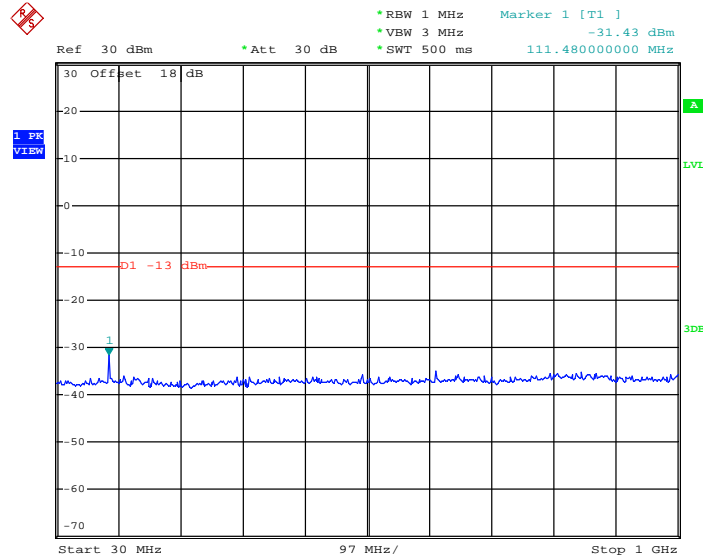

Date: 5.DEC.2013 13:03:55

Conducted Spurious Emission Plot between 1GHz ~ 3GHz

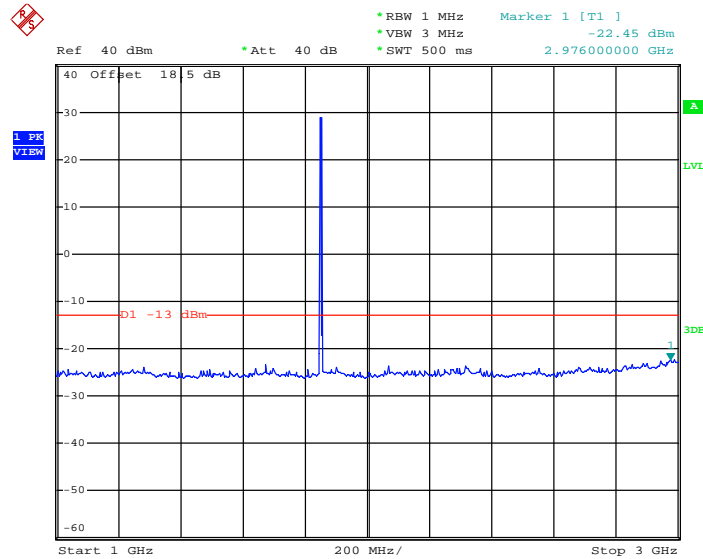

Date: 5.DEC.2013 13:01:23



Conducted Spurious Emission Plot between 3GHz ~ 7GHz

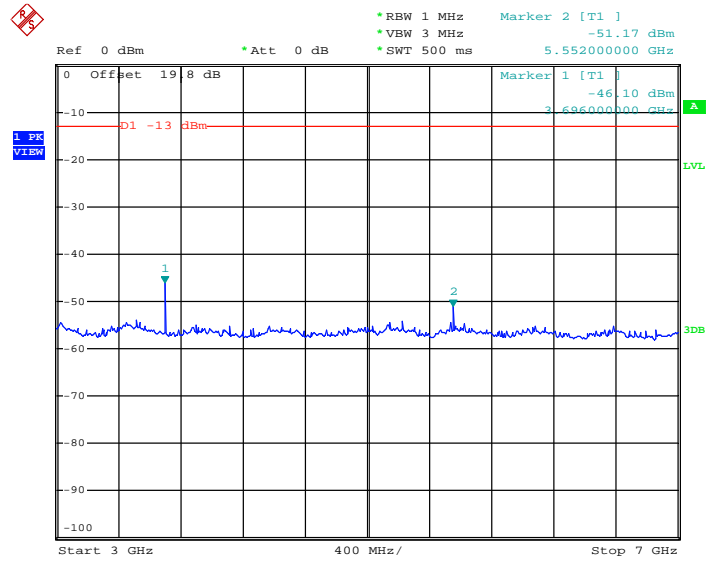

Date: 5.DEC.2013 13:05:35

Conducted Spurious Emission Plot between 7GHz ~ 13.6GHz

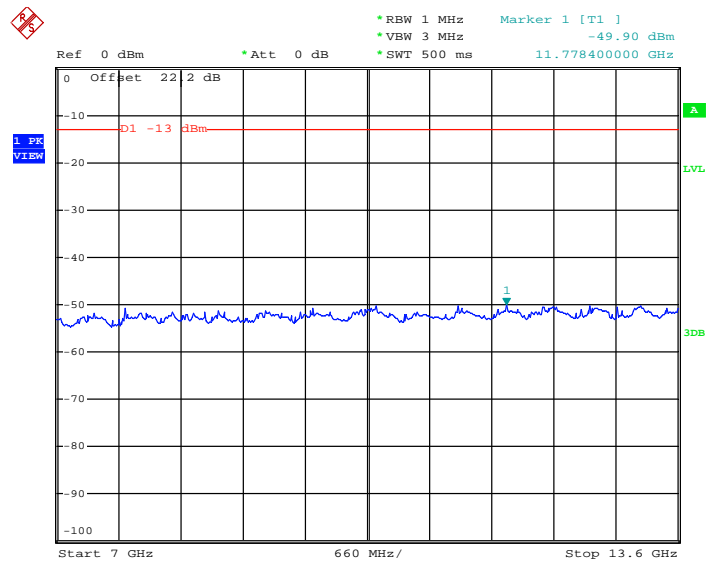

Date: 5.DEC.2013 13:10:24



Conducted Spurious Emission Plot between 13.6GHz ~ 19.1GHz

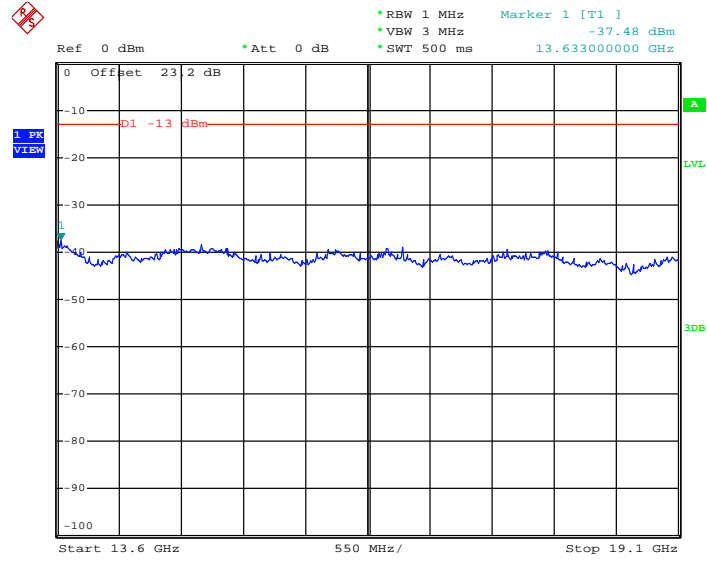

Date: 5.DEC.2013 13:11:18



| | | | |
|-------------|-----------------|-------------|------------|
| Band : | GSM1900 | Channel : | CH661 |
| Test Mode : | GSM Link (GMSK) | Frequency : | 1880.0 MHz |

Conducted Spurious Emission Plot between 30MHz ~ 1GHz

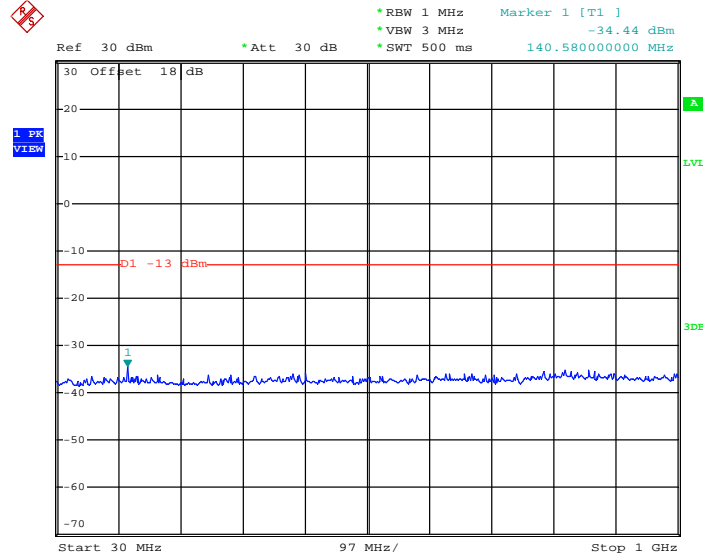

Date: 5.DEC.2013 13:03:19

Conducted Spurious Emission Plot between 1GHz ~ 3GHz

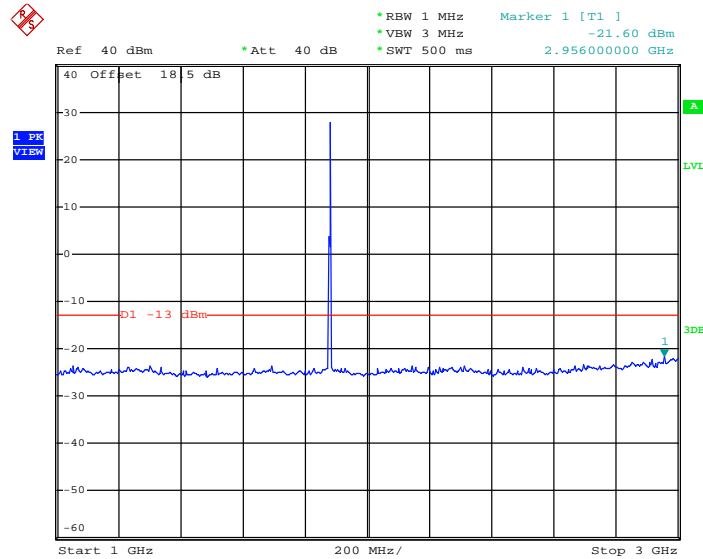

Date: 5.DEC.2013 13:00:28



Conducted Spurious Emission Plot between 3GHz ~ 7GHz

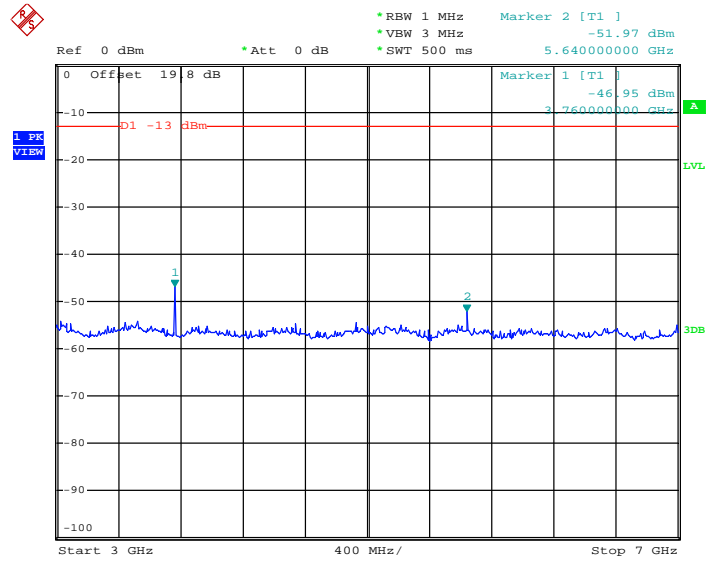

Date: 5.DEC.2013 13:06:09

Conducted Emission Plot between 7GHz ~ 13.6GHz

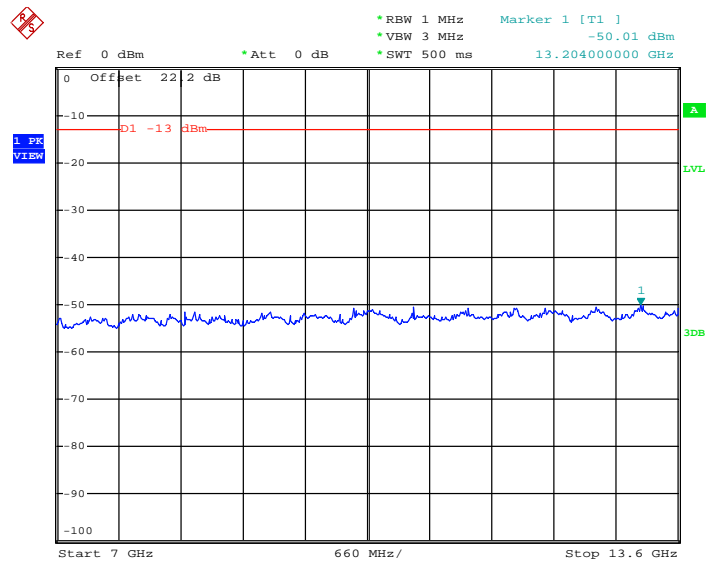

Date: 5.DEC.2013 13:08:32



Conducted Spurious Emission Plot between 13.6GHz ~ 19.1GHz

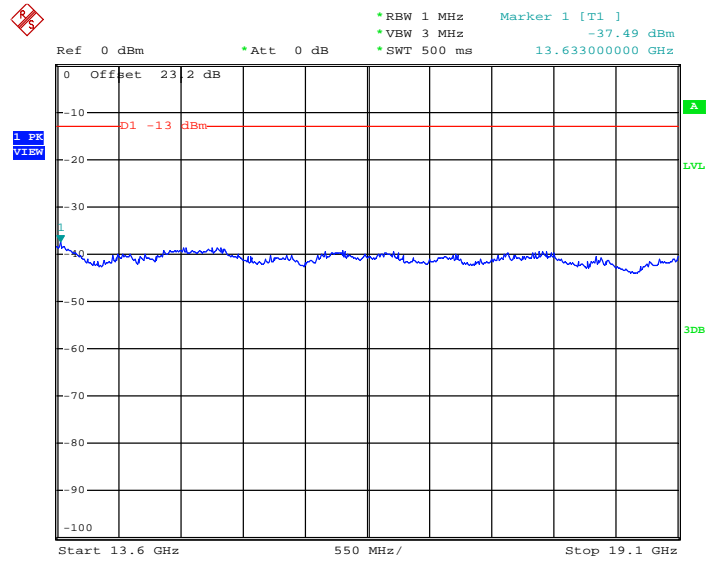

Date: 5.DEC.2013 13:12:48



| | | | |
|-------------|-----------------|-------------|------------|
| Band : | GSM1900 | Channel : | CH810 |
| Test Mode : | GSM Link (GMSK) | Frequency : | 1909.8 MHz |

Conducted Spurious Emission Plot between 30MHz ~ 1GHz

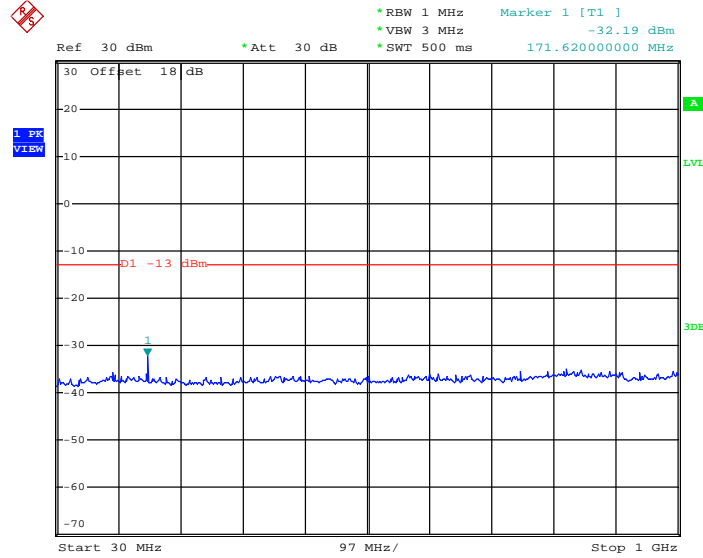

Date: 5.DEC.2013 13:02:52

Conducted Spurious Emission Plot between 1GHz ~ 3GHz

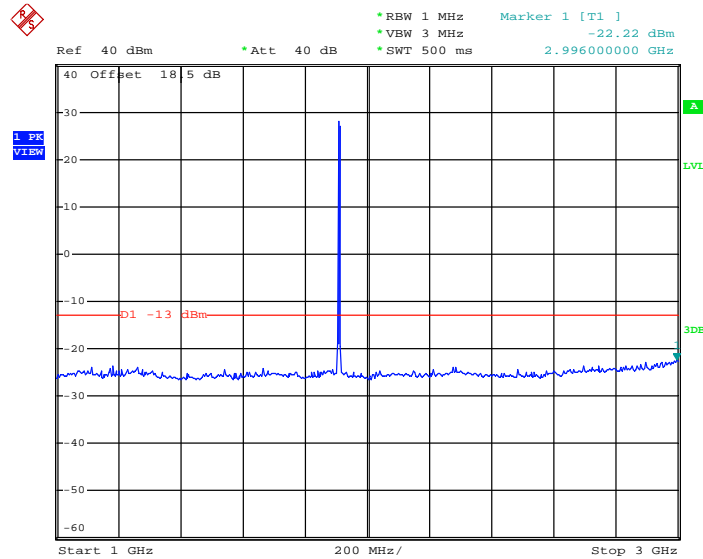

Date: 5.DEC.2013 13:02:08



Conducted Spurious Emission Plot between 3GHz ~ 7GHz

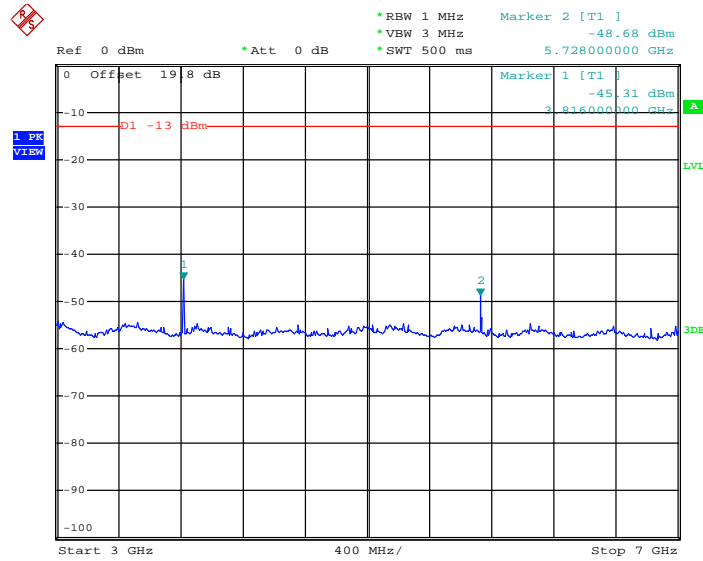

Date: 5.DEC.2013 13:06:59

Conducted Spurious Emission Plot between 7GHz ~ 13.6GHz

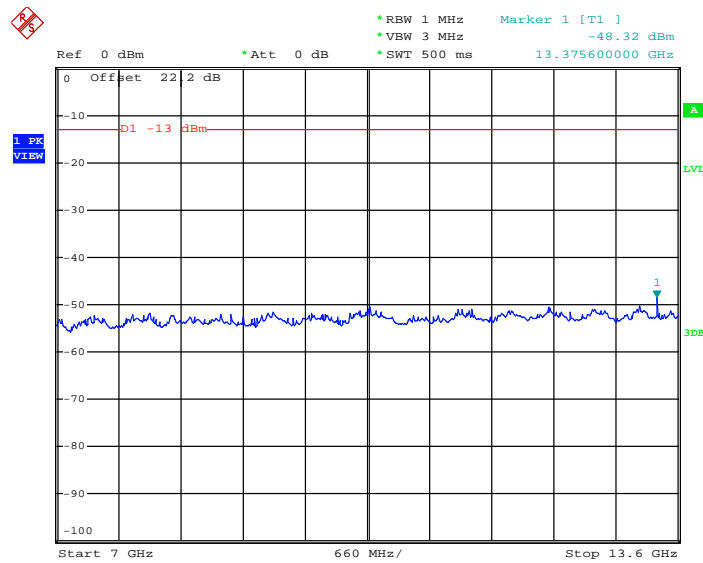

Date: 5.DEC.2013 13:07:42



Conducted Spurious Emission Plot between 13.6GHz ~ 19.1GHz

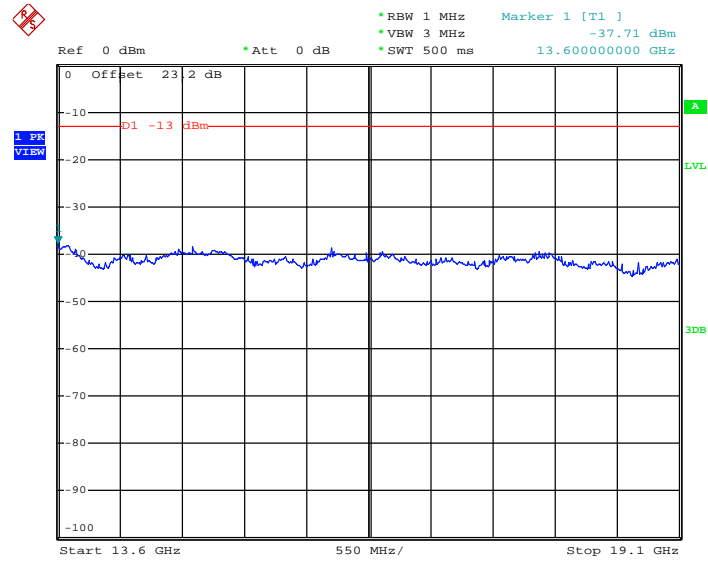

Date: 5.DEC.2013 13:13:39

3.7 Field Strength of Spurious Radiation Measurement

3.7.1 Description of Field Strength of Spurious Radiated Measurement

The power of any emission outside of the authorized operating frequency ranges must be attenuated below the transmitter power (P) by a factor of at least $43 + 10 \log (P)$ dB. The spectrum is scanned from 30 MHz up to a frequency including its 10th harmonic.

3.7.2 Measuring Instruments

The measuring equipment is listed in the section 4 of this test report.

3.7.3 Test Procedures

1. The EUT was placed on a rotatable wooden table with 0.8 meter above ground.
2. The EUT was set 3 meters from the receiving antenna, which was mounted on the antenna tower.
3. The table was rotated 360 degrees to determine the position of the highest spurious emission.
4. The height of the receiving antenna is varied between one meter and four meters to search the maximum spurious emission for both horizontal and vertical polarizations.
5. Make the measurement with the spectrum analyzer's RBW = 1MHz, VBW = 3MHz, taking the record of maximum spurious emission.
6. A horn antenna was substituted in place of the EUT and was driven by a signal generator.
7. Tune the output power of signal generator to the same emission level with EUT maximum spurious emission.
8. Taking the record of output power at antenna port.
9. Repeat step 7 to step 8 for another polarization.
10. The RF fundamental frequency should be excluded against the limit line in the operating frequency band.
11. The limit line is derived from $43 + 10\log(P)$ dB below the transmitter power P(Watts)
 $= P(W) - [43 + 10\log(P)]$ (dB)
 $= [30 + 10\log(P)]$ (dBm) - $[43 + 10\log(P)]$ (dB)
 $= -13$ dBm.
12. EIRP (dBm) = S.G. Power – Tx Cable Loss + Tx Antenna Gain
13. ERP (dBm) = EIRP - 2.15

3.7.4 Test Setup

For radiated emissions from 30MHz to 1GHz

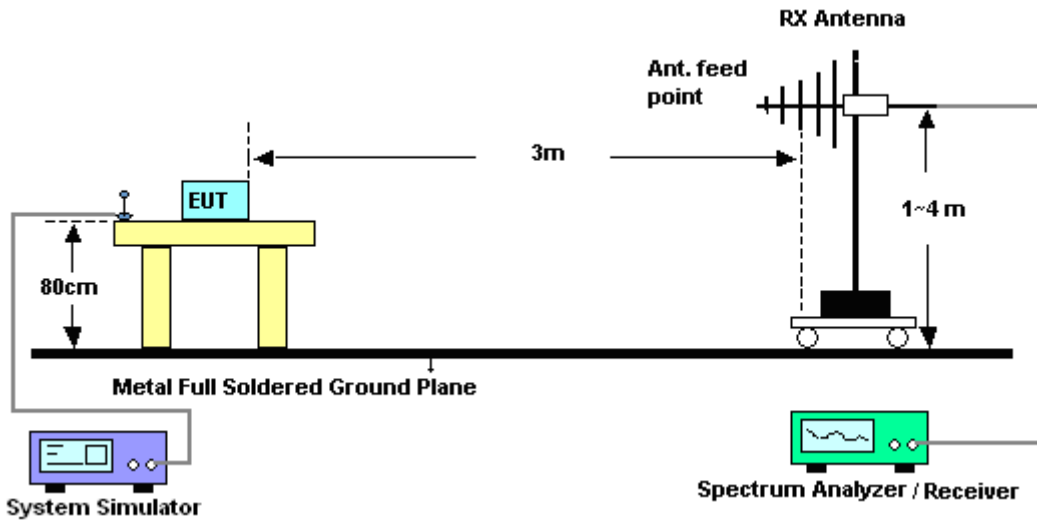

For radiated emissions above 1GHz

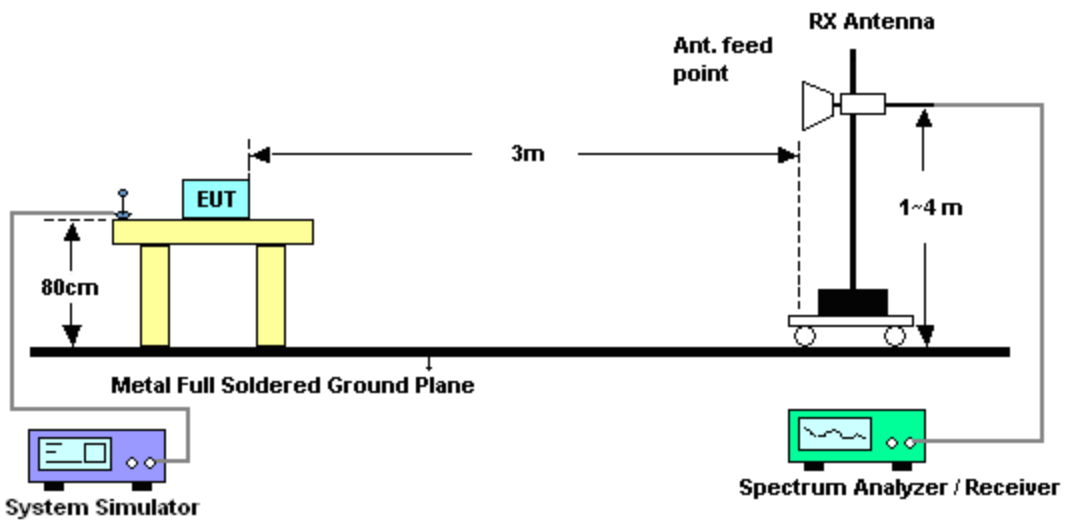



3.7.5 Test Result of Field Strength of Spurious Radiated

<SIM1>

| | | | |
|-----------------|--|---------------------|------------|
| Band : | GSM850 for CH128 | Temperature : | 23~25°C |
| Test Mode : | GSM Link (GMSK) | Relative Humidity : | 48~52% |
| Test Engineer : | Gavin Zhang | Polarization : | Horizontal |
| Remark : | Spurious emissions within 30-1000MHz were found more than 20dB below limit line. | | |

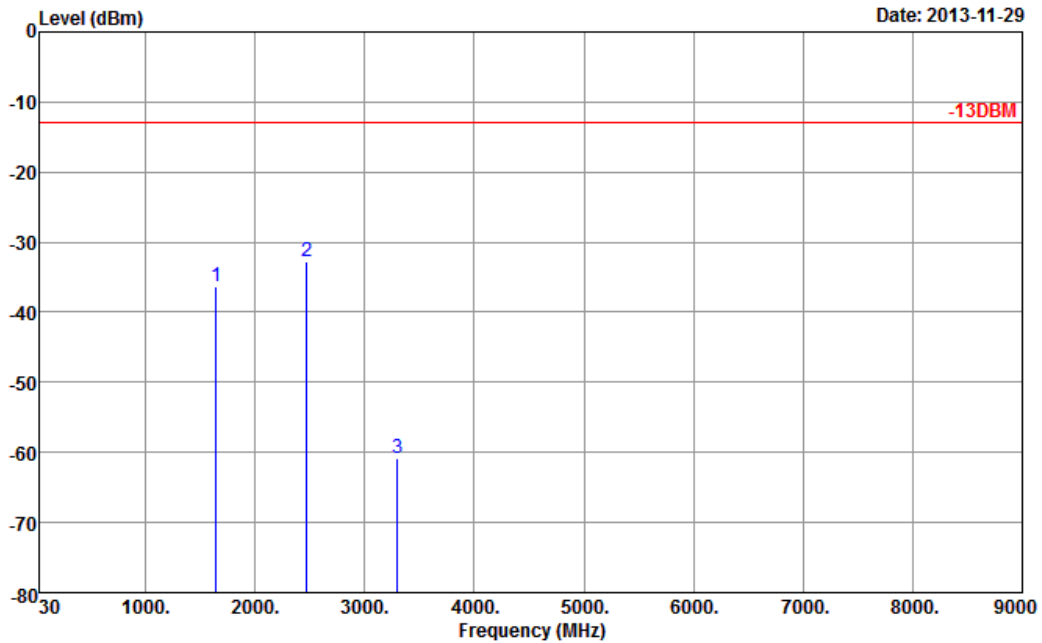

Site : 03CH01-SZ
 Condition : -13DBM HF_EIRP_H_130101 HORIZONTAL
 Project : (FG) 3N2607

| Frequency (MHz) | ERP (dBm) | Limit (dBm) | Over Limit (dB) | SPA Reading (dBm) | S.G. Power (dBm) | TX Cable loss (dB) | TX Antenna Gain (dBi) | Polarization (H/V) | Result |
|-------------------|-------------|---------------|-------------------|---------------------|--------------------|----------------------|-------------------------|----------------------|--------|
| 1648.4 | -36.35 | -13 | -23.35 | -53.73 | -39.17 | 0.73 | 5.70 | H | Pass |
| 2472.6 | -32.65 | -13 | -19.65 | -58.14 | -35.01 | 0.91 | 5.42 | H | Pass |
| 3296.8 | -60.93 | -13 | -47.93 | -71.80 | -65.57 | 1.07 | 7.86 | H | Pass |



| | | | |
|------------------------|--|----------------------------|----------|
| Band : | GSM850 for CH128 | Temperature : | 23~25°C |
| Test Mode : | GSM Link (GMSK) | Relative Humidity : | 48~52% |
| Test Engineer : | Gavin Zhang | Polarization : | Vertical |
| Remark : | Spurious emissions within 30-1000MHz were found more than 20dB below limit line. | | |

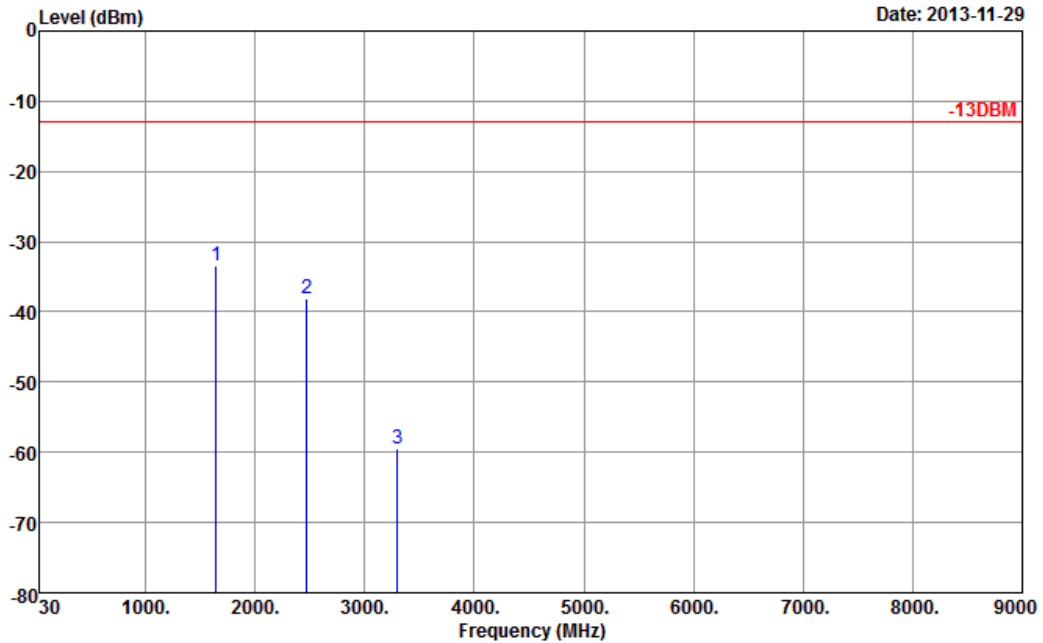

Site : 03CH01-SZ
 Condition : -13DBM HF_EIRP_V_130101 VERTICAL
 Project : (FG) 3N2607

| Frequency (MHz) | ERP (dBm) | Limit (dBm) | Over Limit (dB) | SPA Reading (dBm) | S.G. Power (dBm) | TX Cable loss (dB) | TX Antenna Gain (dBi) | Polarization (H/V) | Result |
|----------------------|----------------|------------------|-------------------------|---------------------------|--------------------------|----------------------------|-------------------------------|-------------------------|--------|
| 1648.4 | -33.32 | -13 | -20.32 | -47.80 | -36.14 | 0.73 | 5.70 | V | Pass |
| 2472.6 | -38.06 | -13 | -25.06 | -60.84 | -40.42 | 0.91 | 5.42 | V | Pass |
| 3296.8 | -59.52 | -13 | -46.52 | -71.70 | -64.16 | 1.07 | 7.86 | V | Pass |



| | | | |
|------------------------|--|----------------------------|------------|
| Band : | GSM850 for CH189 | Temperature : | 23~25°C |
| Test Mode : | GSM Link (GMSK) | Relative Humidity : | 48~52% |
| Test Engineer : | Gavin Zhang | Polarization : | Horizontal |
| Remark : | Spurious emissions within 30-1000MHz were found more than 20dB below limit line. | | |

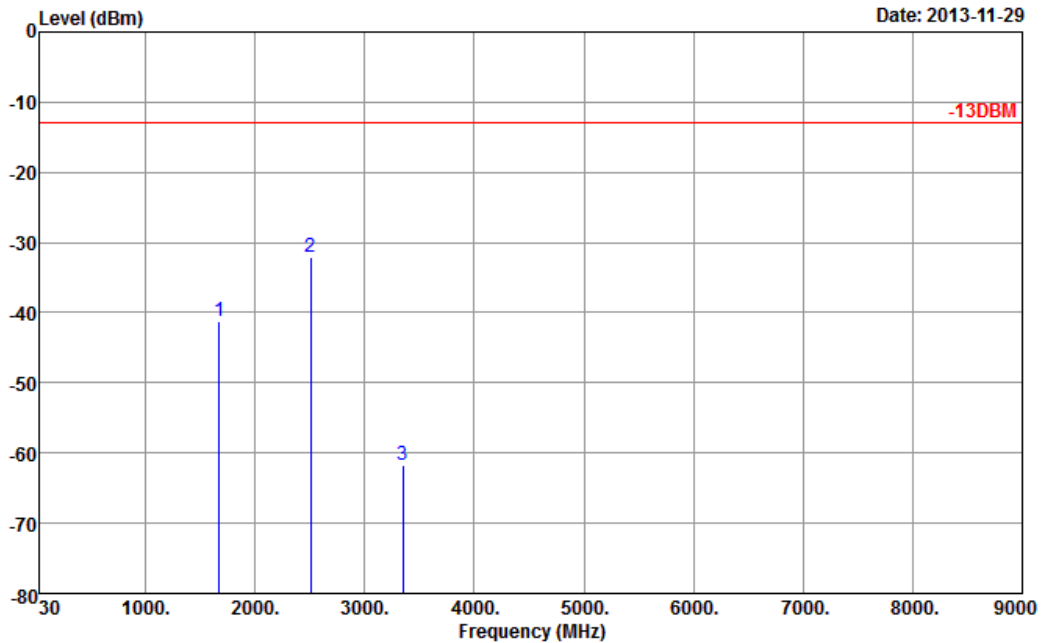

Site : 03CH01-SZ
 Condition : -13DBM HF_EIRP_H_130101 HORIZONTAL
 Project : (FG) 3N2607

| Frequency (MHz) | ERP (dBm) | Limit (dBm) | Over Limit (dB) | SPA Reading (dBm) | S.G. Power (dBm) | TX Cable loss (dB) | TX Antenna Gain (dBi) | Polarization (H/V) | Result |
|-------------------|-------------|---------------|-------------------|---------------------|--------------------|----------------------|-------------------------|----------------------|--------|
| 1672 | -41.21 | -13 | -28.21 | -57.75 | -44.18 | 0.88 | 6.00 | H | Pass |
| 2510 | -32.08 | -13 | -19.08 | -57.27 | -34.69 | 1.08 | 5.84 | H | Pass |
| 3346 | -61.76 | -13 | -48.76 | -72.36 | -66.13 | 1.14 | 7.66 | H | Pass |



| | | | |
|------------------------|--|----------------------------|----------|
| Band : | GSM850 for CH189 | Temperature : | 23~25°C |
| Test Mode : | GSM Link (GMSK) | Relative Humidity : | 48~52% |
| Test Engineer : | Gavin Zhang | Polarization : | Vertical |
| Remark : | Spurious emissions within 30-1000MHz were found more than 20dB below limit line. | | |

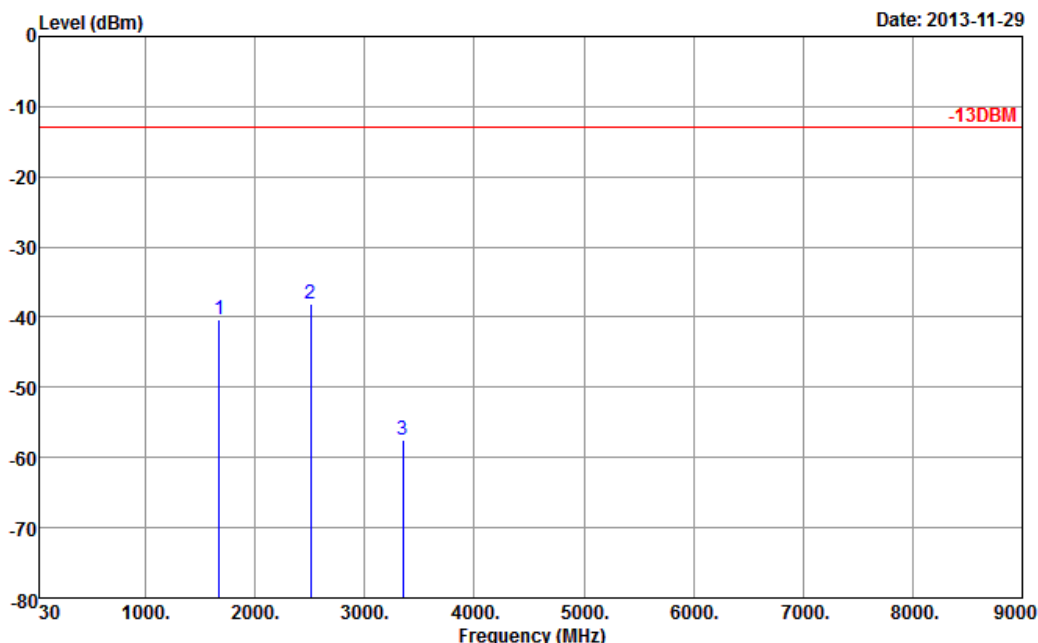

Site : 03CH01-SZ
 Condition : -13DBM HF_EIRP_V_130101 VERTICAL
 Project : (FG) 3N2607

| Frequency (MHz) | ERP (dBm) | Limit (dBm) | Over Limit (dB) | SPA Reading (dBm) | S.G. Power (dBm) | TX Cable loss (dB) | TX Antenna Gain (dBi) | Polarization (H/V) | Result |
|----------------------|----------------|------------------|-------------------------|---------------------------|--------------------------|----------------------------|-------------------------------|-------------------------|--------|
| 1672 | -40.42 | -13 | -27.42 | -53.98 | -43.39 | 0.88 | 6.00 | V | Pass |
| 2510 | -38.07 | -13 | -25.07 | -60.55 | -40.68 | 1.08 | 5.84 | V | Pass |
| 3346 | -57.58 | -13 | -44.58 | -69.41 | -61.95 | 1.14 | 7.66 | V | Pass |



| | | | |
|------------------------|--|----------------------------|------------|
| Band : | GSM850 for CH251 | Temperature : | 23~25°C |
| Test Mode : | GSM Link (GMSK) | Relative Humidity : | 48~52% |
| Test Engineer : | Gavin Zhang | Polarization : | Horizontal |
| Remark : | Spurious emissions within 30-1000MHz were found more than 20dB below limit line. | | |

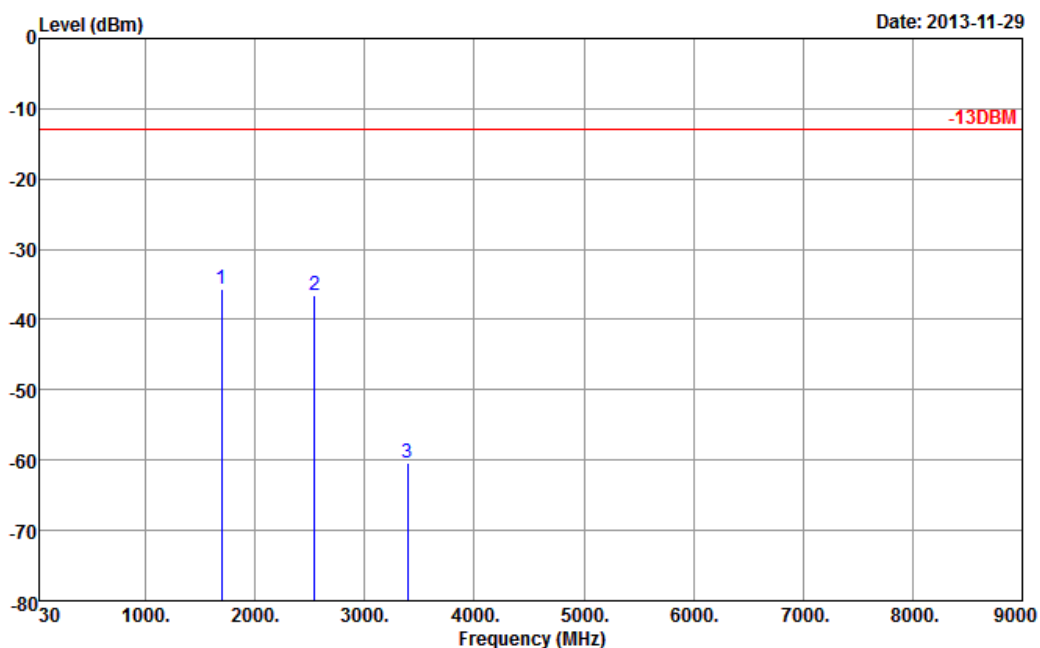

Site : 03CH01-SZ
 Condition : -13DBM HF_EIRP_H_130101 HORIZONTAL
 Project : (FG) 3N2607

| Frequency (MHz) | ERP (dBm) | Limit (dBm) | Over Limit (dB) | SPA Reading (dBm) | S.G. Power (dBm) | TX Cable loss (dB) | TX Antenna Gain (dBi) | Polarization (H/V) | Result |
|-------------------|-------------|---------------|-------------------|---------------------|--------------------|----------------------|-------------------------|----------------------|--------|
| 1697.6 | -35.66 | -13 | -22.66 | -52.87 | -38.65 | 0.75 | 5.89 | H | Pass |
| 2546.4 | -36.44 | -13 | -23.44 | -61.62 | -39.15 | 1.12 | 5.98 | H | Pass |
| 3395.2 | -60.33 | -13 | -47.33 | -71.53 | -64.73 | 1.25 | 7.80 | H | Pass |



| | | | |
|------------------------|--|----------------------------|----------|
| Band : | GSM850 for CH251 | Temperature : | 23~25°C |
| Test Mode : | GSM Link (GMSK) | Relative Humidity : | 48~52% |
| Test Engineer : | Gavin Zhang | Polarization : | Vertical |
| Remark : | Spurious emissions within 30-1000MHz were found more than 20dB below limit line. | | |

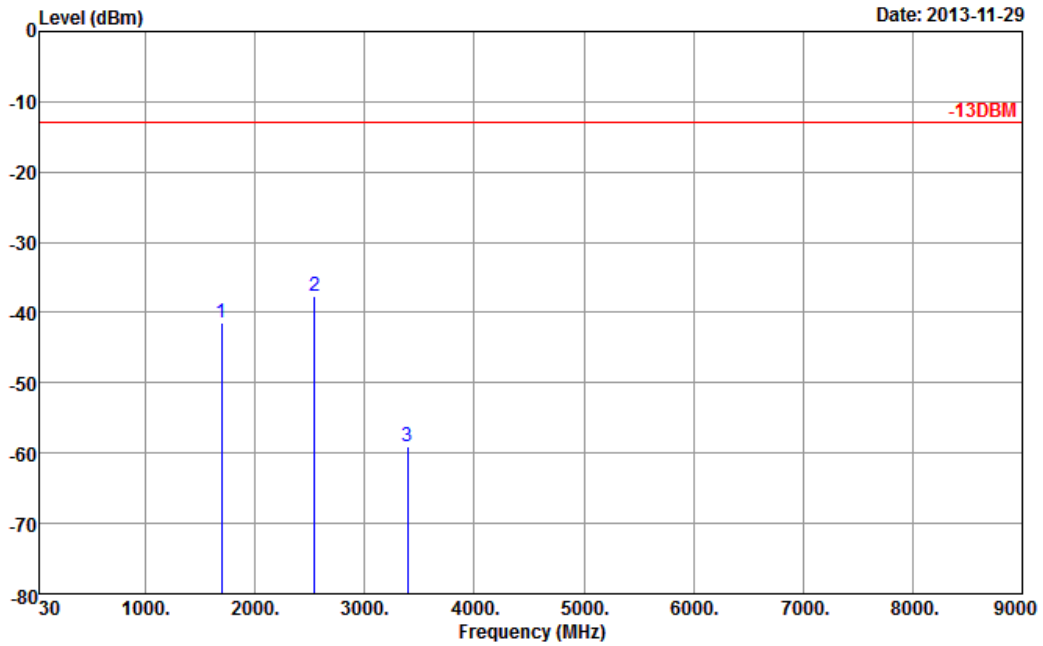

Site : 03CH01-SZ
 Condition : -13DBM HF_EIRP_V_130101 VERTICAL
 Project : (FG) 3N2607

| Frequency (MHz) | ERP (dBm) | Limit (dBm) | Over Limit (dB) | SPA Reading (dBm) | S.G. Power (dBm) | TX Cable loss (dB) | TX Antenna Gain (dBi) | Polarization (H/V) | Result |
|----------------------|----------------|------------------|-------------------------|---------------------------|--------------------------|----------------------------|-------------------------------|-------------------------|--------|
| 1697.6 | -41.52 | -13 | -28.52 | -55.42 | -44.51 | 0.75 | 5.89 | V | Pass |
| 2546.4 | -37.72 | -13 | -24.72 | -60.61 | -40.43 | 1.12 | 5.98 | V | Pass |
| 3395.2 | -59.04 | -13 | -46.04 | -71.47 | -63.44 | 1.25 | 7.80 | V | Pass |



| | | | |
|------------------------|--|----------------------------|------------|
| Band : | GSM1900 for CH512 | Temperature : | 23~25°C |
| Test Mode : | GSM Link (GMSK) | Relative Humidity : | 48~52% |
| Test Engineer : | Gavin Zhang | Polarization : | Horizontal |
| Remark : | Spurious emissions within 30-1000MHz were found more than 20dB below limit line. | | |

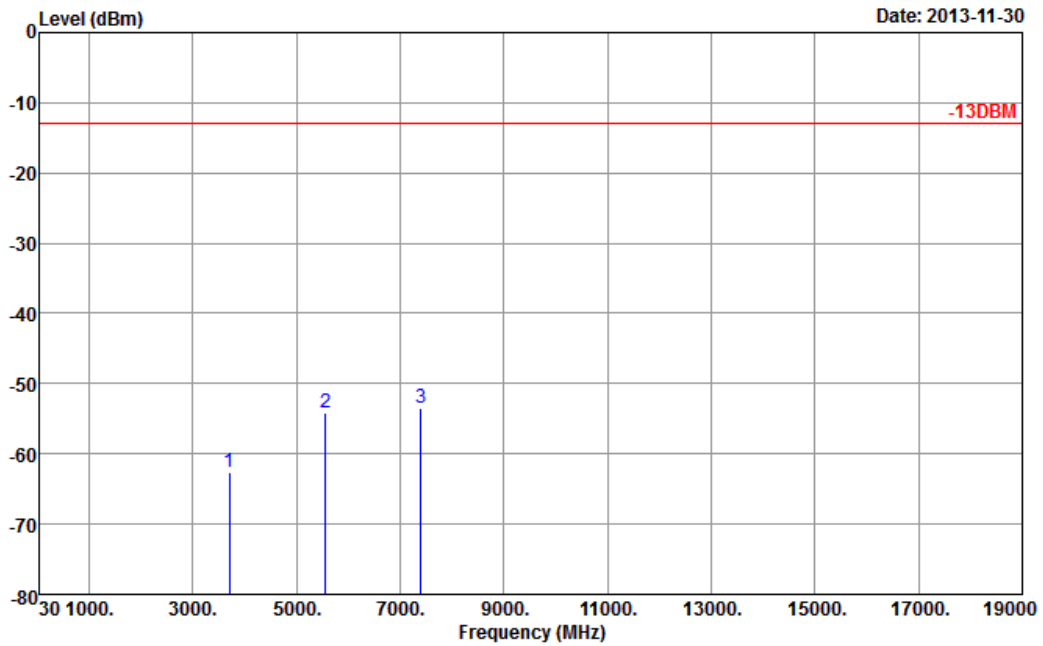

Site : 03CH01-SZ
 Condition : -13DBM HF_EIRP_H_130101 HORIZONTAL
 Project : (FG) 3N2607

| Frequency (MHz) | EIRP (dBm) | Limit (dBm) | Over Limit (dB) | SPA Reading (dBm) | S.G. Power (dBm) | TX Cable loss (dB) | TX Antenna Gain (dBi) | Polarization (H/V) | Result |
|-------------------|--------------|---------------|-------------------|---------------------|--------------------|----------------------|-------------------------|----------------------|--------|
| 3700.4 | -62.61 | -13 | -49.61 | -74.16 | -69.36 | 1.2 | 7.95 | H | Pass |
| 5550.6 | -54.13 | -13 | -41.13 | -71.52 | -62.23 | 1.5 | 9.60 | H | Pass |
| 7400.8 | -53.56 | -13 | -40.56 | -75.14 | -63.75 | 1.7 | 11.89 | H | Pass |



| | | | |
|------------------------|--|----------------------------|----------|
| Band : | GSM1900 for CH512 | Temperature : | 23~25°C |
| Test Mode : | GSM Link (GMSK) | Relative Humidity : | 48~52% |
| Test Engineer : | Gavin Zhang | Polarization : | Vertical |
| Remark : | Spurious emissions within 30-1000MHz were found more than 20dB below limit line. | | |

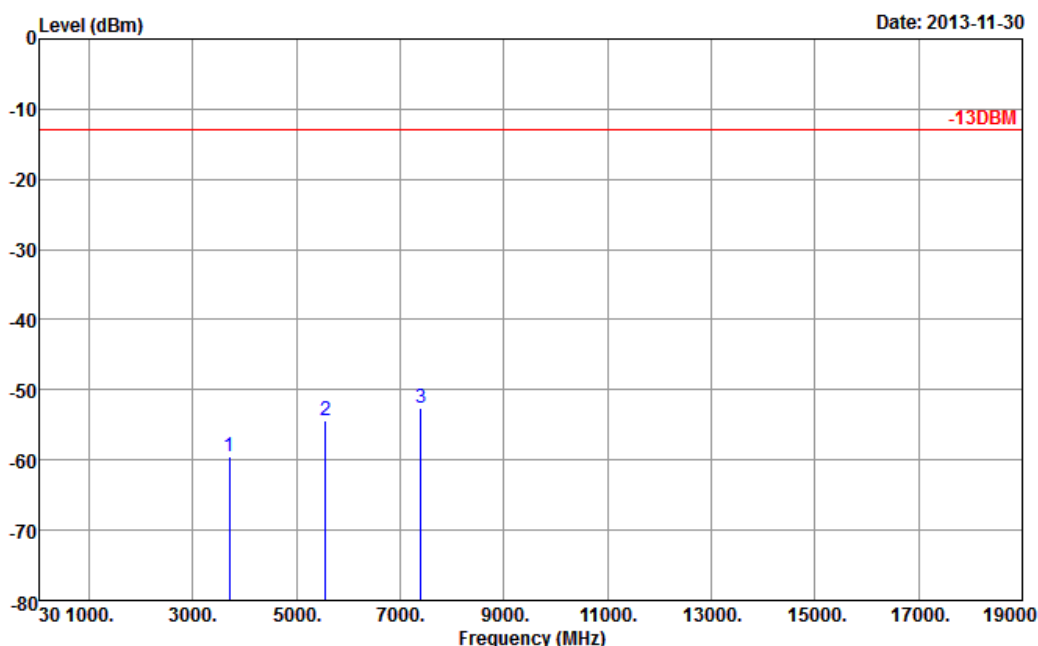

Site : 03CH01-SZ
 Condition : -13DBM HF_EIRP_V_130101 VERTICAL
 Project : (FG) 3N2607

| Frequency (MHz) | EIRP (dBm) | Limit (dBm) | Over Limit (dB) | SPA Reading (dBm) | S.G. Power (dBm) | TX Cable loss (dB) | TX Antenna Gain (dBi) | Polarization (H/V) | Result |
|-------------------|--------------|---------------|-------------------|---------------------|--------------------|----------------------|-------------------------|----------------------|--------|
| 3700.4 | -59.47 | -13 | -46.47 | -73.9 | -66.22 | 1.2 | 7.95 | V | Pass |
| 5550.6 | -54.39 | -13 | -41.39 | -70.87 | -62.49 | 1.5 | 9.6 | V | Pass |
| 7400.8 | -52.65 | -13 | -39.65 | -74.54 | -62.84 | 1.7 | 11.89 | V | Pass |



| | | | |
|------------------------|--|----------------------------|------------|
| Band : | GSM1900 for CH661 | Temperature : | 23~25°C |
| Test Mode : | GSM Link (GMSK) | Relative Humidity : | 48~52% |
| Test Engineer : | Gavin Zhang | Polarization : | Horizontal |
| Remark : | Spurious emissions within 30-1000MHz were found more than 20dB below limit line. | | |

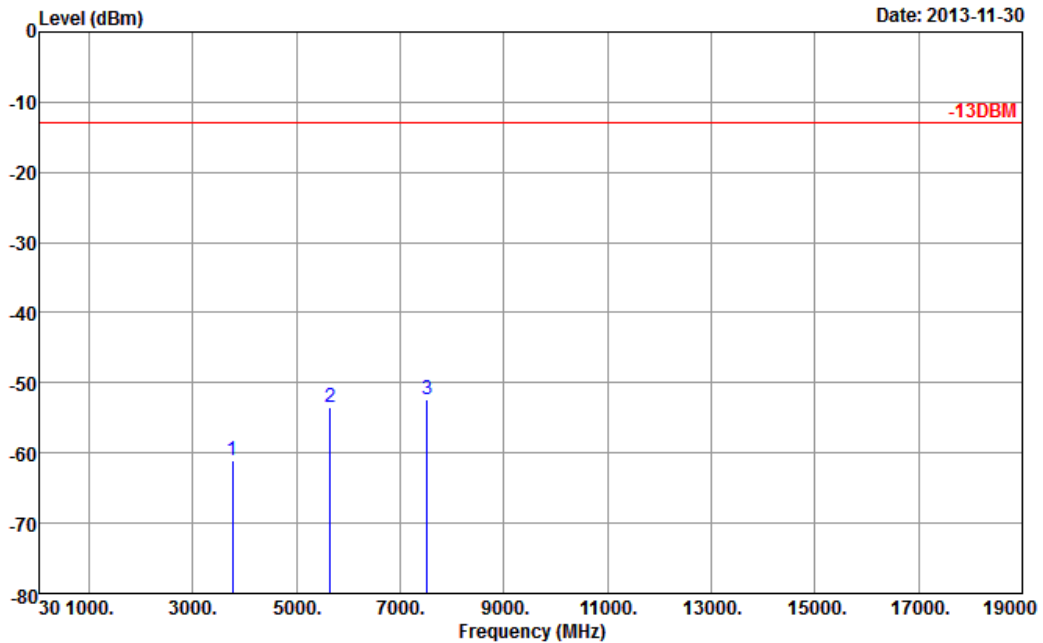

Site : 03CH01-SZ
 Condition : -13DBM HF_EIRP_H_130101 HORIZONTAL
 Project : (FG) 3N2607

| Frequency (MHz) | EIRP (dBm) | Limit (dBm) | Over Limit (dB) | SPA Reading (dBm) | S.G. Power (dBm) | TX Cable loss (dB) | TX Antenna Gain (dBi) | Polarization (H/V) | Result |
|-------------------|--------------|---------------|-------------------|---------------------|--------------------|----------------------|-------------------------|----------------------|--------|
| 3760 | -60.97 | -13 | -47.97 | -73.12 | -67.71 | 1.28 | 8.02 | H | Pass |
| 5640 | -53.53 | -13 | -40.53 | -71.52 | -61.95 | 1.58 | 10.00 | H | Pass |
| 7520 | -52.27 | -13 | -39.27 | -74.21 | -62.59 | 1.78 | 12.10 | H | Pass |



| | | | |
|------------------------|--|----------------------------|----------|
| Band : | GSM1900 for CH661 | Temperature : | 23~25°C |
| Test Mode : | GSM Link (GMSK) | Relative Humidity : | 48~52% |
| Test Engineer : | Gavin Zhang | Polarization : | Vertical |
| Remark : | Spurious emissions within 30-1000MHz were found more than 20dB below limit line. | | |

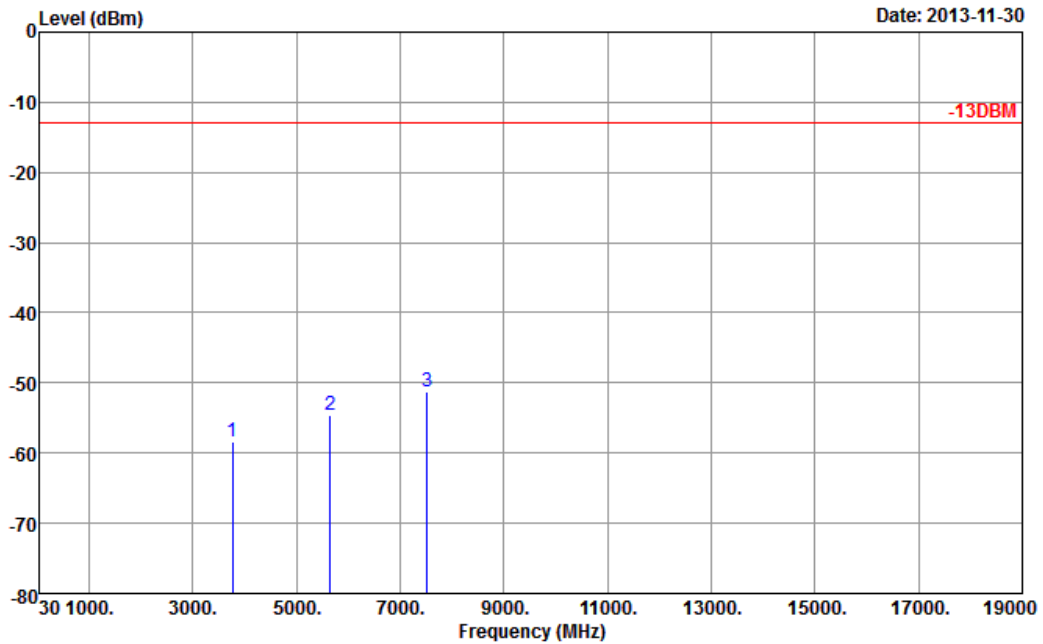

Site : 03CH01-SZ
 Condition : -13DBM HF_EIRP_V_130101 VERTICAL
 Project : (FG) 3N2607

| Frequency (MHz) | EIRP (dBm) | Limit (dBm) | Over Limit (dB) | SPA Reading (dBm) | S.G. Power (dBm) | TX Cable loss (dB) | TX Antenna Gain (dBi) | Polarization (H/V) | Result |
|-------------------|--------------|---------------|-------------------|---------------------|--------------------|----------------------|-------------------------|----------------------|--------|
| 3760 | -58.44 | -13 | -45.44 | -73.47 | -65.18 | 1.28 | 8.02 | V | Pass |
| 5640 | -54.52 | -13 | -41.52 | -71.6 | -62.94 | 1.58 | 10 | V | Pass |
| 7520 | -51.18 | -13 | -38.18 | -73.43 | -61.50 | 1.78 | 12.1 | V | Pass |



| | | | |
|------------------------|--|----------------------------|------------|
| Band : | GSM1900 for CH810 | Temperature : | 23~25°C |
| Test Mode : | GSM Link (GMSK) | Relative Humidity : | 48~52% |
| Test Engineer : | Gavin Zhang | Polarization : | Horizontal |
| Remark : | Spurious emissions within 30-1000MHz were found more than 20dB below limit line. | | |

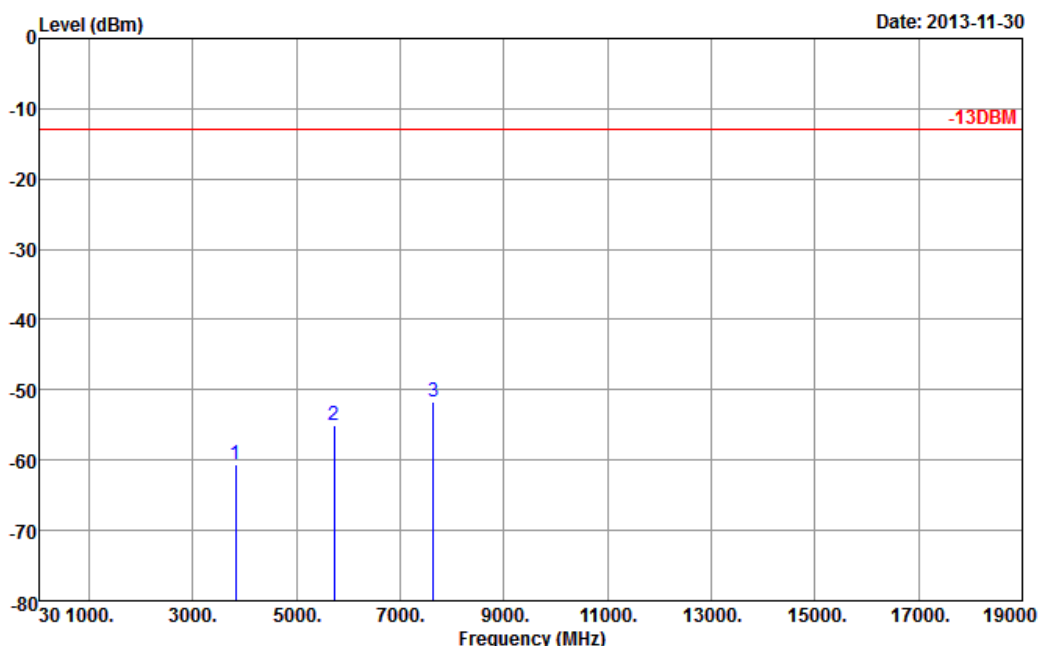

Site : 03CH01-SZ
 Condition : -13DBM HF_EIRP_H_130101 HORIZONTAL
 Project : (FG) 3N2607

| Frequency (MHz) | EIRP (dBm) | Limit (dBm) | Over Limit (dB) | SPA Reading (dBm) | S.G. Power (dBm) | TX Cable loss (dB) | TX Antenna Gain (dBi) | Polarization (H/V) | Result |
|-------------------|--------------|---------------|-------------------|---------------------|--------------------|----------------------|-------------------------|----------------------|--------|
| 3819.6 | -60.66 | -13 | -47.66 | -72.23 | -67.43 | 1.23 | 8.00 | H | Pass |
| 5729.4 | -55.10 | -13 | -42.10 | -72.90 | -63.23 | 1.52 | 9.65 | H | Pass |
| 7639.2 | -51.71 | -13 | -38.71 | -73.95 | -61.89 | 1.82 | 12.00 | H | Pass |



| | | | |
|------------------------|--|----------------------------|----------|
| Band : | GSM1900 for CH810 | Temperature : | 23~25°C |
| Test Mode : | GSM Link (GMSK) | Relative Humidity : | 48~52% |
| Test Engineer : | Gavin Zhang | Polarization : | Vertical |
| Remark : | Spurious emissions within 30-1000MHz were found more than 20dB below limit line. | | |

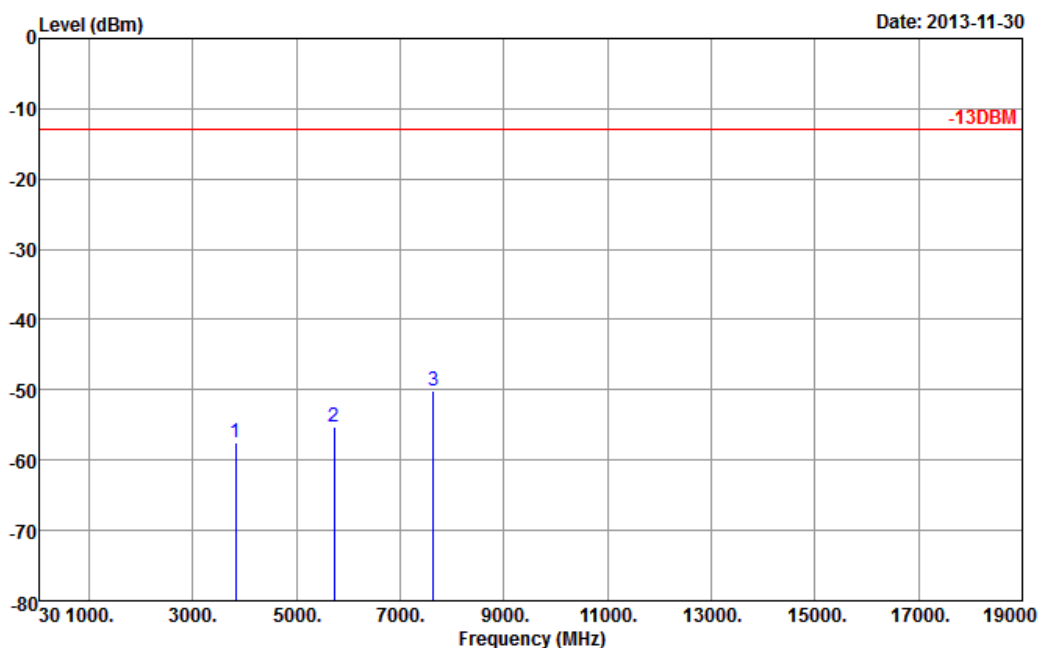

Site : 03CH01-SZ
 Condition : -13DBM HF_EIRP_V_130101 VERTICAL
 Project : (FG) 3N2607

| Frequency (MHz) | EIRP (dBm) | Limit (dBm) | Over Limit (dB) | SPA Reading (dBm) | S.G. Power (dBm) | TX Cable loss (dB) | TX Antenna Gain (dBi) | Polarization (H/V) | Result |
|-------------------|--------------|---------------|-------------------|---------------------|--------------------|----------------------|-------------------------|----------------------|--------|
| 3819.6 | -57.47 | -13 | -44.47 | -71.92 | -64.24 | 1.23 | 8 | V | Pass |
| 5729.4 | -55.31 | -13 | -42.31 | -72.2 | -63.44 | 1.52 | 9.65 | V | Pass |
| 7639.2 | -50.21 | -13 | -37.21 | -72.76 | -60.39 | 1.82 | 12 | V | Pass |



<SIM2>

| | | | |
|------------------------|--|----------------------------|------------|
| Band : | GSM850 for CH128 | Temperature : | 23~25°C |
| Test Mode : | GSM Link (GMSK) | Relative Humidity : | 48~52% |
| Test Engineer : | Gavin Zhang | Polarization : | Horizontal |
| Remark : | Spurious emissions within 30-1000MHz were found more than 20dB below limit line. | | |

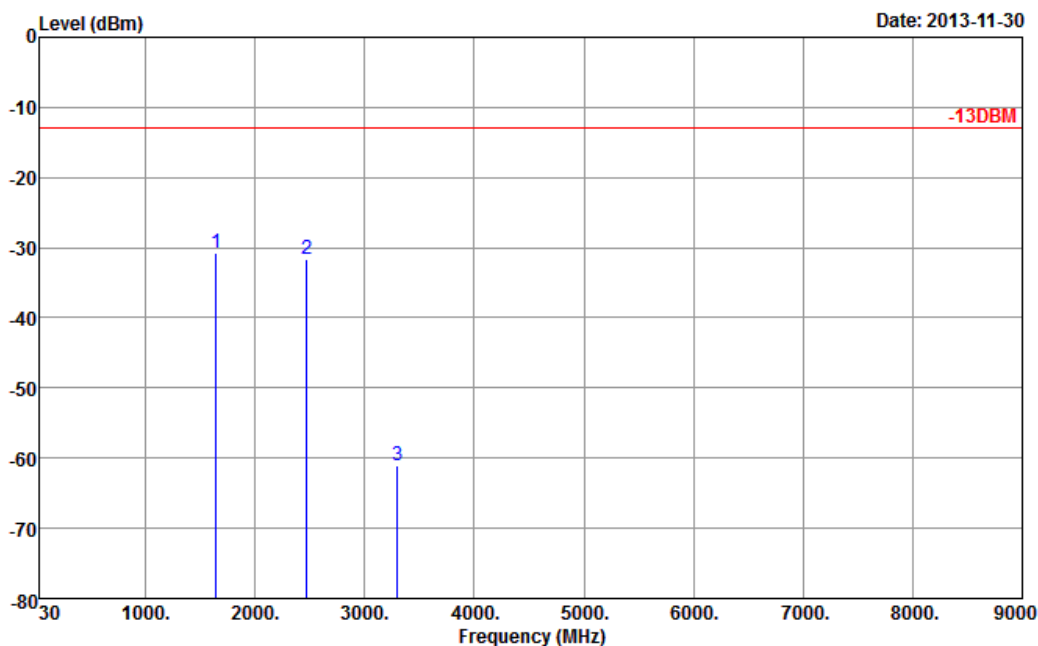

Site : 03CH01-SZ
 Condition : -13DBM HF_EIRP_H_130101 HORIZONTAL
 Project : (FG) 3N2607

| Frequency (MHz) | ERP (dBm) | Limit (dBm) | Over Limit (dB) | SPA Reading (dBm) | S.G. Power (dBm) | TX Cable loss (dB) | TX Antenna Gain (dBi) | Polarization (H/V) | Result |
|-------------------|-------------|---------------|-------------------|---------------------|--------------------|----------------------|-------------------------|----------------------|--------|
| 1648.4 | -30.69 | -13 | -17.69 | -47.60 | -33.51 | 0.73 | 5.70 | H | Pass |
| 2472.6 | -31.60 | -13 | -18.60 | -57.11 | -33.96 | 0.91 | 5.42 | H | Pass |
| 3296.8 | -60.97 | -13 | -47.97 | -71.84 | -65.61 | 1.07 | 7.86 | H | Pass |



| | | | |
|------------------------|--|----------------------------|----------|
| Band : | GSM850 for CH128 | Temperature : | 23~25°C |
| Test Mode : | GSM Link (GMSK) | Relative Humidity : | 48~52% |
| Test Engineer : | Gavin Zhang | Polarization : | Vertical |
| Remark : | Spurious emissions within 30-1000MHz were found more than 20dB below limit line. | | |

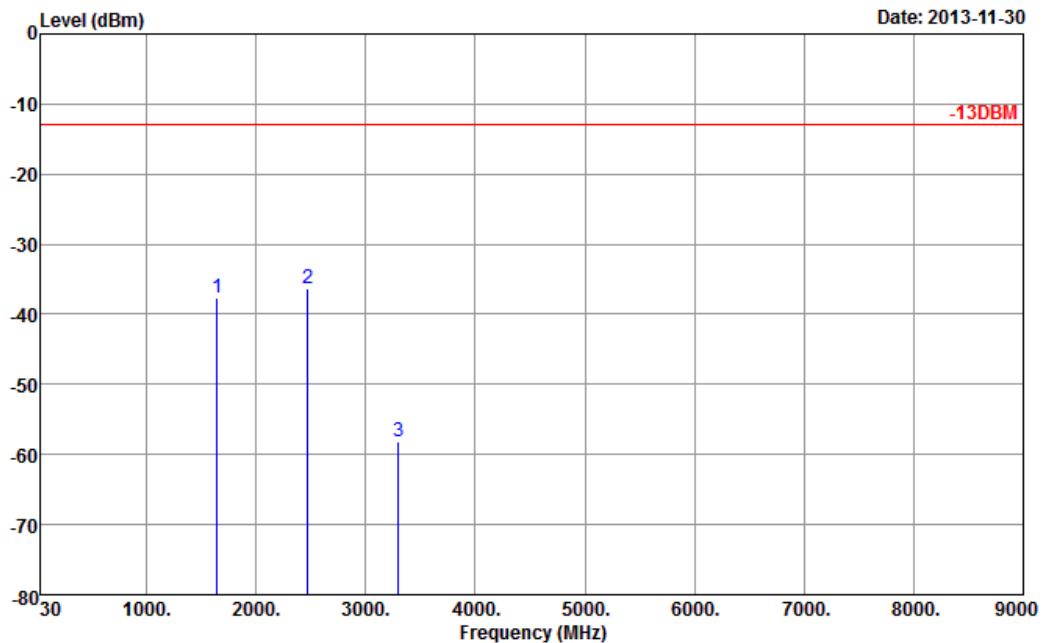

Site : 03CH01-SZ
 Condition : -13DBM HF_EIRP_V_130101 VERTICAL
 Project : (FG) 3N2607

| Frequency (MHz) | ERP (dBm) | Limit (dBm) | Over Limit (dB) | SPA Reading (dBm) | S.G. Power (dBm) | TX Cable loss (dB) | TX Antenna Gain (dBi) | Polarization (H/V) | Result |
|-------------------|-------------|---------------|-------------------|---------------------|--------------------|----------------------|-------------------------|----------------------|--------|
| 1648.4 | -37.77 | -13 | -24.77 | -52.20 | -40.59 | 0.73 | 5.70 | V | Pass |
| 2472.6 | -36.31 | -13 | -23.31 | -59.14 | -38.67 | 0.91 | 5.42 | V | Pass |
| 3296.8 | -58.23 | -13 | -45.23 | -70.41 | -62.87 | 1.07 | 7.86 | V | Pass |



| | | | |
|------------------------|--|----------------------------|------------|
| Band : | GSM850 for CH189 | Temperature : | 23~25°C |
| Test Mode : | GSM Link (GMSK) | Relative Humidity : | 48~52% |
| Test Engineer : | Gavin Zhang | Polarization : | Horizontal |
| Remark : | Spurious emissions within 30-1000MHz were found more than 20dB below limit line. | | |

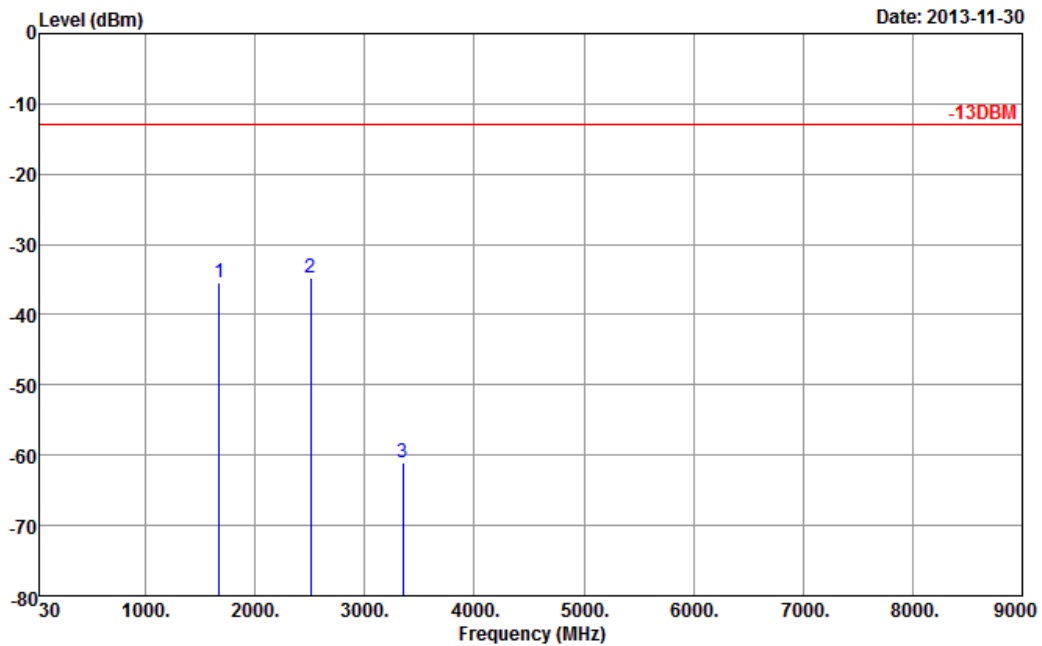

Site : 03CH01-SZ
 Condition : -13DBM HF_EIRP_H_130101 HORIZONTAL
 Project : (FG) 3N2607

| Frequency (MHz) | ERP (dBm) | Limit (dBm) | Over Limit (dB) | SPA Reading (dBm) | S.G. Power (dBm) | TX Cable loss (dB) | TX Antenna Gain (dBi) | Polarization (H/V) | Result |
|-------------------|-------------|---------------|-------------------|---------------------|--------------------|----------------------|-------------------------|----------------------|--------|
| 1672 | -35.37 | -13 | -22.37 | -52.21 | -38.34 | 0.88 | 6.00 | H | Pass |
| 2510 | -34.67 | -13 | -21.67 | -59.64 | -37.28 | 1.08 | 5.84 | H | Pass |
| 3346 | -61.06 | -13 | -48.06 | -71.66 | -65.43 | 1.14 | 7.66 | H | Pass |



| | | | |
|------------------------|--|----------------------------|----------|
| Band : | GSM850 for CH189 | Temperature : | 23~25°C |
| Test Mode : | GSM Link (GMSK) | Relative Humidity : | 48~52% |
| Test Engineer : | Gavin Zhang | Polarization : | Vertical |
| Remark : | Spurious emissions within 30-1000MHz were found more than 20dB below limit line. | | |

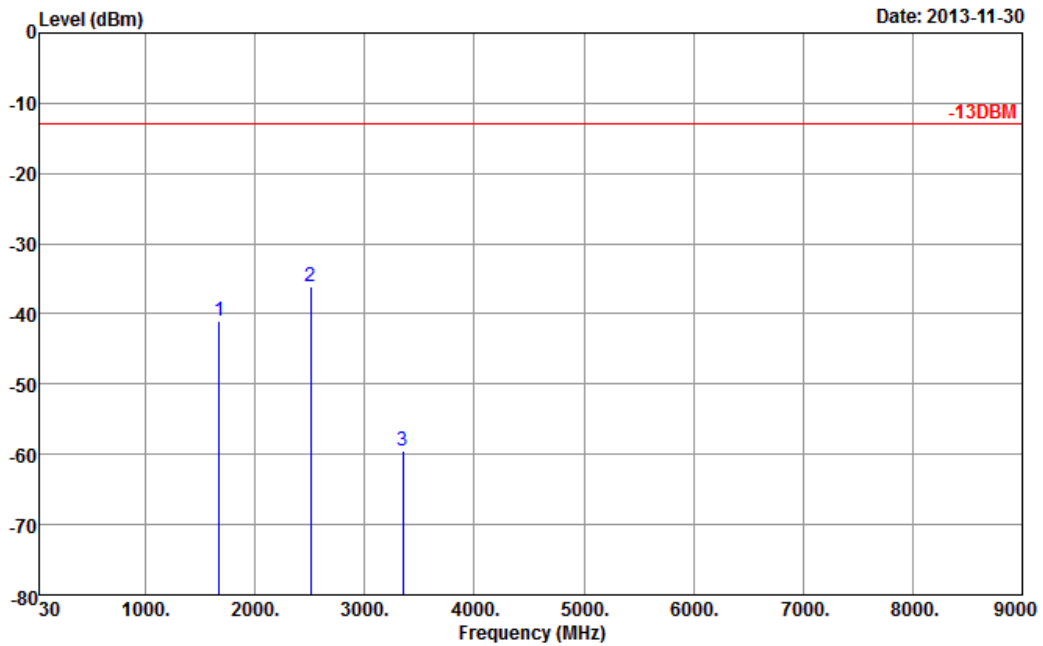

Site : 03CH01-SZ
 Condition : -13DBM HF_EIRP_V_130101 VERTICAL
 Project : (FG) 3N2607

| Frequency (MHz) | ERP (dBm) | Limit (dBm) | Over Limit (dB) | SPA Reading (dBm) | S.G. Power (dBm) | TX Cable loss (dB) | TX Antenna Gain (dBi) | Polarization (H/V) | Result |
|----------------------|----------------|------------------|-------------------------|---------------------------|--------------------------|----------------------------|-------------------------------|-------------------------|--------|
| 1672 | -41.00 | -13 | -28.00 | -54.62 | -43.97 | 0.88 | 6.00 | V | Pass |
| 2510 | -36.16 | -13 | -23.16 | -58.71 | -38.77 | 1.08 | 5.84 | V | Pass |
| 3346 | -59.43 | -13 | -46.43 | -71.26 | -63.80 | 1.14 | 7.66 | V | Pass |



| | | | |
|------------------------|--|----------------------------|------------|
| Band : | GSM850 for CH251 | Temperature : | 23~25°C |
| Test Mode : | GSM Link (GMSK) | Relative Humidity : | 48~52% |
| Test Engineer : | Gavin Zhang | Polarization : | Horizontal |
| Remark : | Spurious emissions within 30-1000MHz were found more than 20dB below limit line. | | |

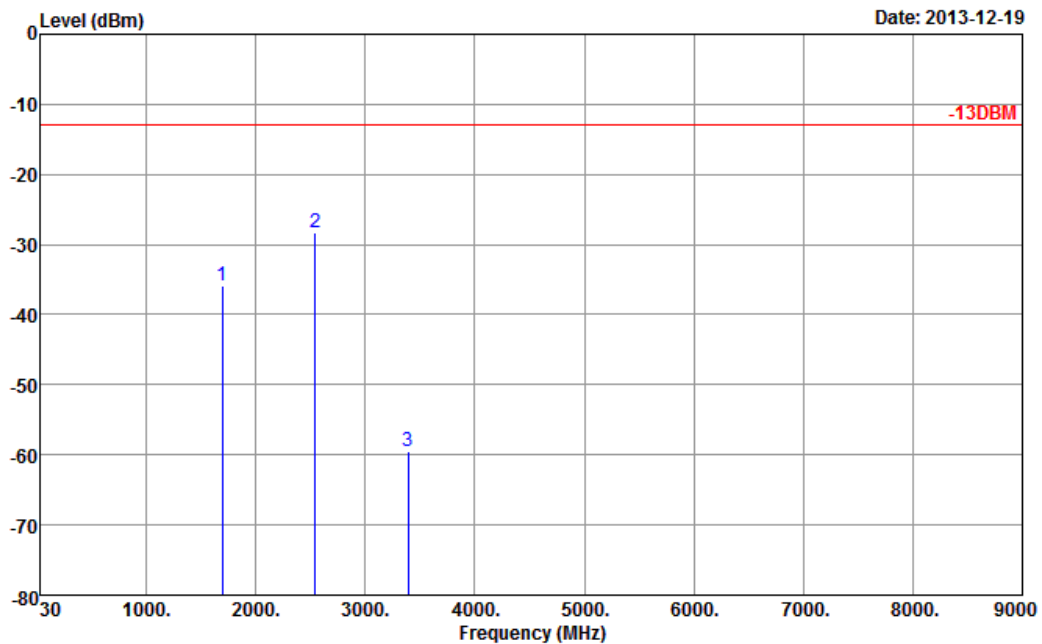

Site : 03CH01-SZ
 Condition : -13DBM HF_EIRP_H_130101 HORIZONTAL
 Project : (FG) 3N2607

| Frequency (MHz) | ERP (dBm) | Limit (dBm) | Over Limit (dB) | SPA Reading (dBm) | S.G. Power (dBm) | TX Cable loss (dB) | TX Antenna Gain (dBi) | Polarization (H/V) | Result |
|----------------------|----------------|------------------|-------------------------|---------------------------|--------------------------|----------------------------|-------------------------------|-------------------------|--------|
| 1697.6 | -35.82 | -13 | -22.82 | -53.04 | -38.81 | 0.75 | 5.89 | H | Pass |
| 2546.4 | -28.22 | -13 | -15.22 | -54.04 | -30.93 | 1.12 | 5.98 | H | Pass |
| 3395.2 | -59.61 | -13 | -46.61 | -70.81 | -64.01 | 1.25 | 7.80 | H | Pass |



| | | | |
|------------------------|--|----------------------------|----------|
| Band : | GSM850 for CH251 | Temperature : | 23~25°C |
| Test Mode : | GSM Link (GMSK) | Relative Humidity : | 48~52% |
| Test Engineer : | Gavin Zhang | Polarization : | Vertical |
| Remark : | Spurious emissions within 30-1000MHz were found more than 20dB below limit line. | | |

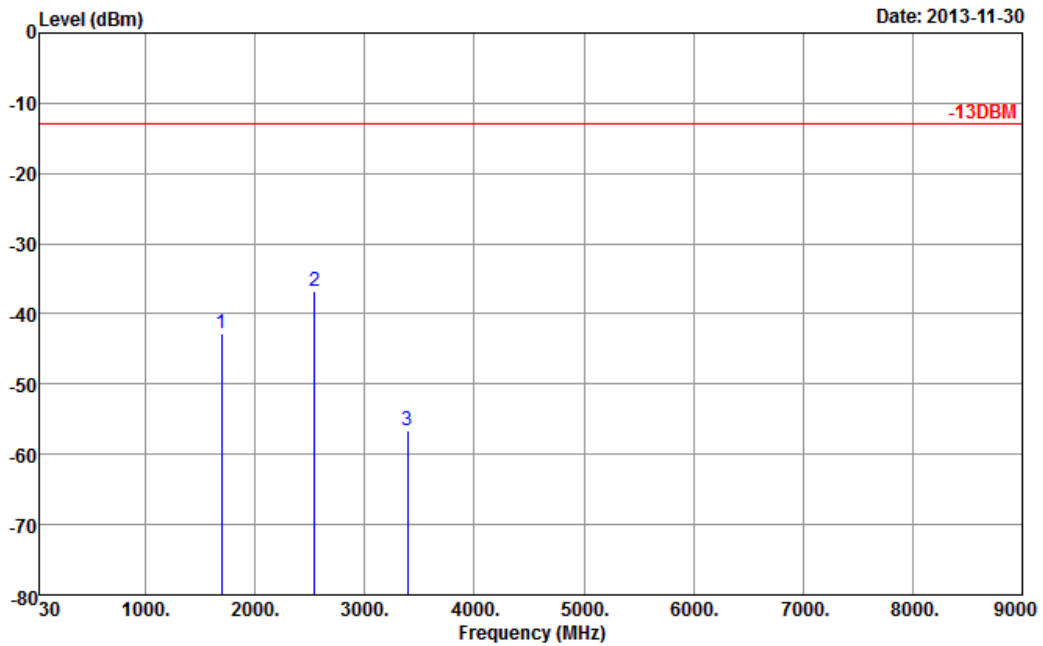

Site : 03CH01-SZ
 Condition : -13DBM HF_EIRP_V_130101 VERTICAL
 Project : (FG) 3N2607

| Frequency (MHz) | ERP (dBm) | Limit (dBm) | Over Limit (dB) | SPA Reading (dBm) | S.G. Power (dBm) | TX Cable loss (dB) | TX Antenna Gain (dBi) | Polarization (H/V) | Result |
|-------------------|-------------|---------------|-------------------|---------------------|--------------------|----------------------|-------------------------|----------------------|--------|
| 1697.6 | -42.79 | -13 | -29.79 | -56.52 | -45.78 | 0.75 | 5.89 | V | Pass |
| 2546.4 | -36.84 | -13 | -23.84 | -59.74 | -39.55 | 1.12 | 5.98 | V | Pass |
| 3395.2 | -56.57 | -13 | -43.57 | -69.00 | -60.97 | 1.25 | 7.80 | V | Pass |



| | | | |
|------------------------|--|----------------------------|------------|
| Band : | GSM1900 for CH512 | Temperature : | 23~25°C |
| Test Mode : | GSM Link (GMSK) | Relative Humidity : | 48~52% |
| Test Engineer : | Gavin Zhang | Polarization : | Horizontal |
| Remark : | Spurious emissions within 30-1000MHz were found more than 20dB below limit line. | | |

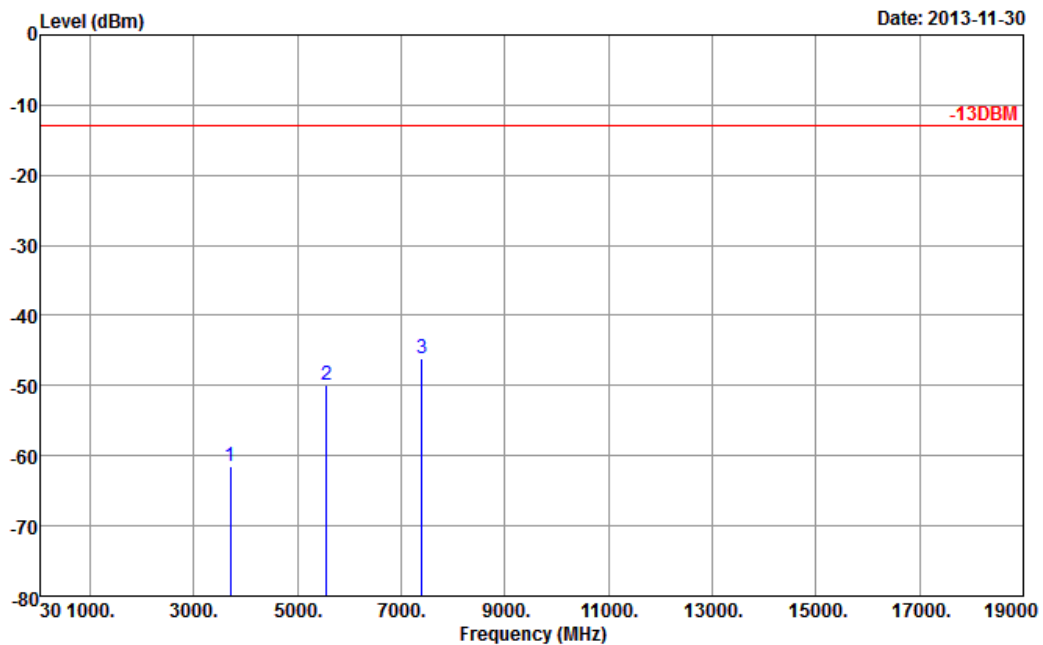

Site : 03CH01-SZ
 Condition : -13DBM HF_EIRP_H_130101 HORIZONTAL
 Project : (FG) 3N2607

| Frequency (MHz) | EIRP (dBm) | Limit (dBm) | Over Limit (dB) | SPA Reading (dBm) | S.G. Power (dBm) | TX Cable loss (dB) | TX Antenna Gain (dBi) | Polarization (H/V) | Result |
|-------------------|--------------|---------------|-------------------|---------------------|--------------------|----------------------|-------------------------|----------------------|--------|
| 3700.4 | -61.46 | -13 | -48.46 | -73.01 | -68.21 | 1.2 | 7.95 | H | Pass |
| 5550.6 | -49.86 | -13 | -36.86 | -67.25 | -57.96 | 1.5 | 9.60 | H | Pass |
| 7400.8 | -46.20 | -13 | -33.20 | -67.78 | -56.39 | 1.7 | 11.89 | H | Pass |



| | | | |
|------------------------|--|----------------------------|----------|
| Band : | GSM1900 for CH512 | Temperature : | 23~25°C |
| Test Mode : | GSM Link (GMSK) | Relative Humidity : | 48~52% |
| Test Engineer : | Gavin Zhang | Polarization : | Vertical |
| Remark : | Spurious emissions within 30-1000MHz were found more than 20dB below limit line. | | |

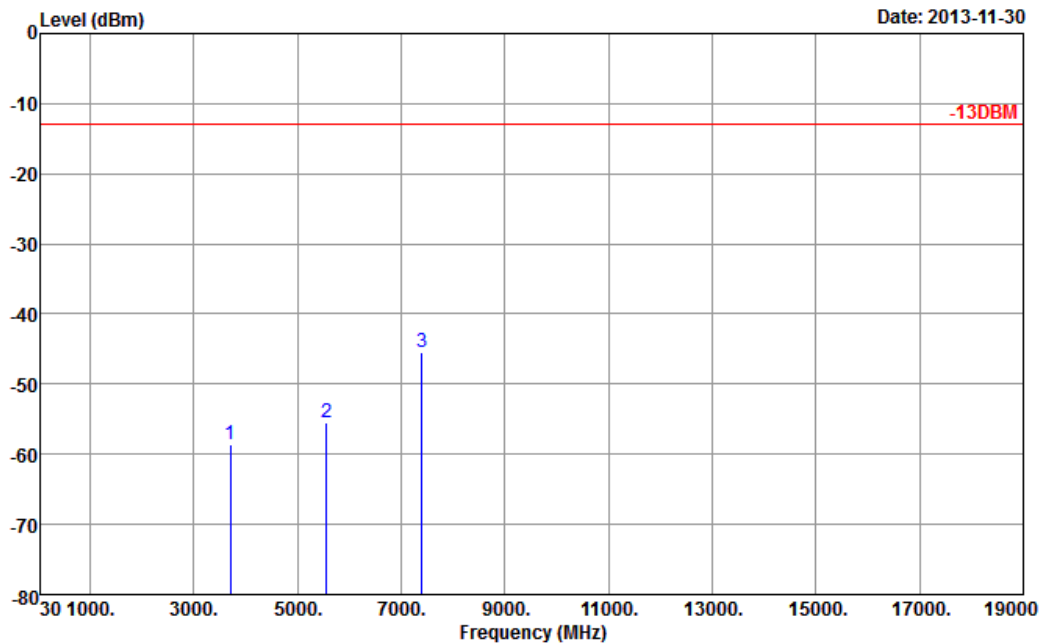

Site : 03CH01-SZ
 Condition : -13DBM HF_EIRP_V_130101 VERTICAL
 Project : (FG) 3N2607

| Frequency (MHz) | EIRP (dBm) | Limit (dBm) | Over Limit (dB) | SPA Reading (dBm) | S.G. Power (dBm) | TX Cable loss (dB) | TX Antenna Gain (dBi) | Polarization (H/V) | Result |
|-------------------|--------------|---------------|-------------------|---------------------|--------------------|----------------------|-------------------------|----------------------|--------|
| 3700.4 | -58.59 | -13 | -45.59 | -73.02 | -65.34 | 1.2 | 7.95 | V | Pass |
| 5550.6 | -55.38 | -13 | -42.38 | -71.86 | -63.48 | 1.5 | 9.6 | V | Pass |
| 7400.8 | -45.55 | -13 | -32.55 | -67.44 | -55.74 | 1.7 | 11.89 | V | Pass |



| | | | |
|------------------------|--|----------------------------|------------|
| Band : | GSM1900 for CH661 | Temperature : | 23~25°C |
| Test Mode : | GSM Link (GMSK) | Relative Humidity : | 48~52% |
| Test Engineer : | Gavin Zhang | Polarization : | Horizontal |
| Remark : | Spurious emissions within 30-1000MHz were found more than 20dB below limit line. | | |

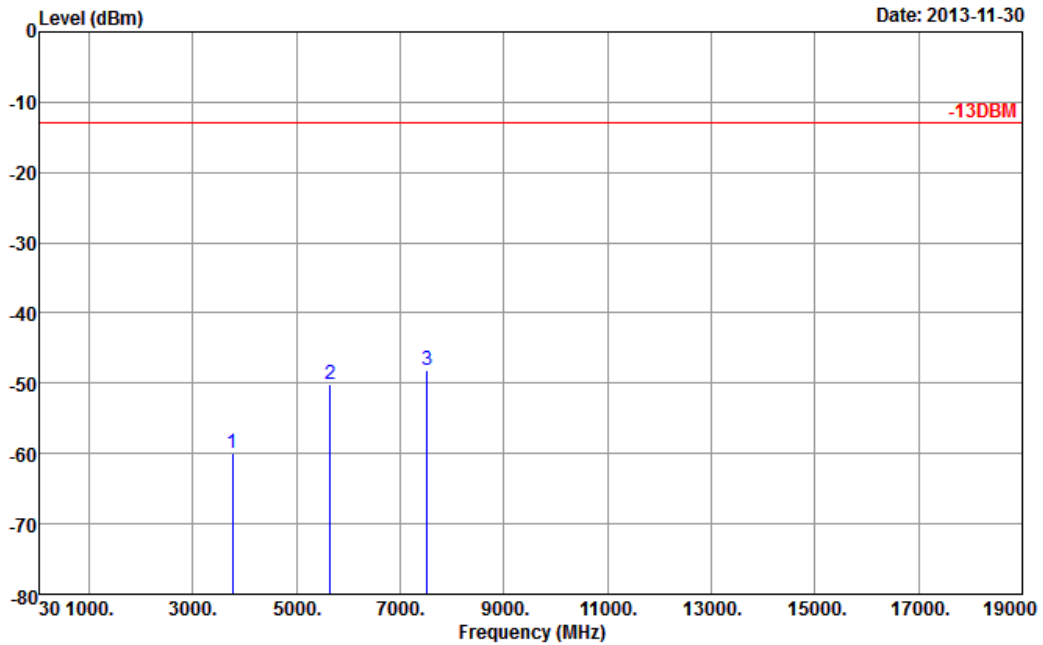

Site : 03CH01-SZ
 Condition : -13DBM HF_EIRP_H_130101 HORIZONTAL
 Project : (FG) 3N2607

| Frequency (MHz) | EIRP (dBm) | Limit (dBm) | Over Limit (dB) | SPA Reading (dBm) | S.G. Power (dBm) | TX Cable loss (dB) | TX Antenna Gain (dBi) | Polarization (H/V) | Result |
|----------------------|-----------------|------------------|-------------------------|---------------------------|--------------------------|----------------------------|-------------------------------|-------------------------|--------|
| 3760 | -60.05 | -13 | -47.05 | -72.20 | -66.79 | 1.28 | 8.02 | H | Pass |
| 5640 | -50.11 | -13 | -37.11 | -68.10 | -58.53 | 1.58 | 10.00 | H | Pass |
| 7520 | -48.19 | -13 | -35.19 | -70.13 | -58.51 | 1.78 | 12.10 | H | Pass |



| | | | |
|------------------------|--|----------------------------|----------|
| Band : | GSM1900 for CH661 | Temperature : | 23~25°C |
| Test Mode : | GSM Link (GMSK) | Relative Humidity : | 48~52% |
| Test Engineer : | Gavin Zhang | Polarization : | Vertical |
| Remark : | Spurious emissions within 30-1000MHz were found more than 20dB below limit line. | | |

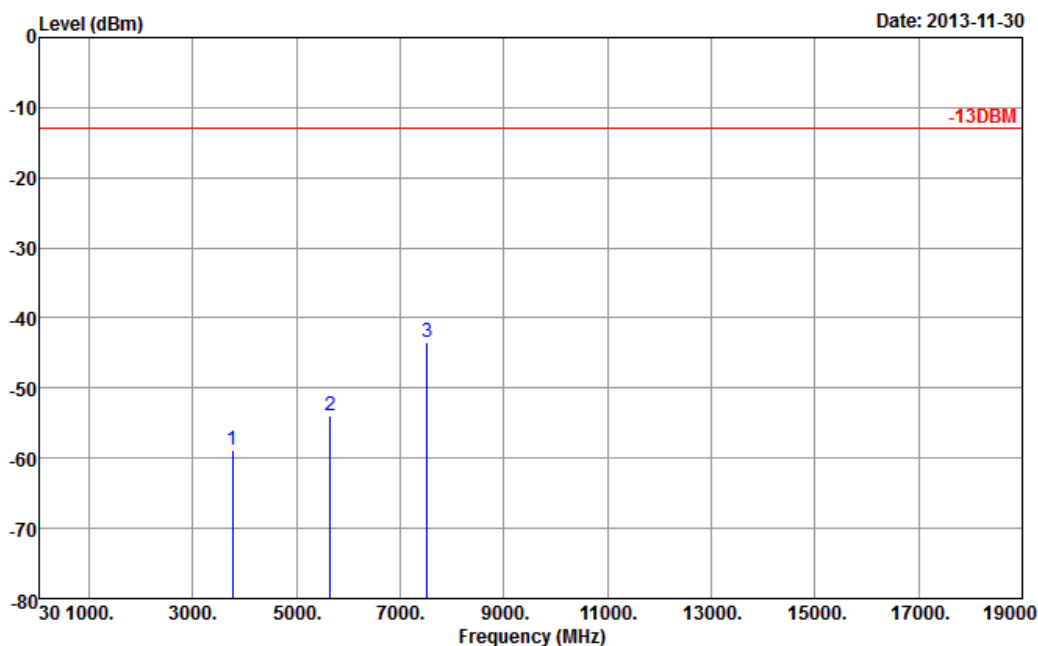

Site : 03CH01-SZ
 Condition : -13DBM HF_EIRP_V_130101 VERTICAL
 Project : (FG) 3N2607

| Frequency (MHz) | EIRP (dBm) | Limit (dBm) | Over Limit (dB) | SPA Reading (dBm) | S.G. Power (dBm) | TX Cable loss (dB) | TX Antenna Gain (dBi) | Polarization (H/V) | Result |
|----------------------|-----------------|------------------|-------------------------|---------------------------|--------------------------|----------------------------|-------------------------------|-------------------------|--------|
| 3760 | -58.87 | -13 | -45.87 | -73.9 | -65.61 | 1.28 | 8.02 | V | Pass |
| 5640 | -53.93 | -13 | -40.93 | -71.01 | -62.35 | 1.58 | 10 | V | Pass |
| 7520 | -43.56 | -13 | -30.56 | -65.81 | -53.88 | 1.78 | 12.1 | V | Pass |



| | | | |
|------------------------|--|----------------------------|------------|
| Band : | GSM1900 for CH810 | Temperature : | 23~25°C |
| Test Mode : | GSM Link (GMSK) | Relative Humidity : | 48~52% |
| Test Engineer : | Gavin Zhang | Polarization : | Horizontal |
| Remark : | Spurious emissions within 30-1000MHz were found more than 20dB below limit line. | | |

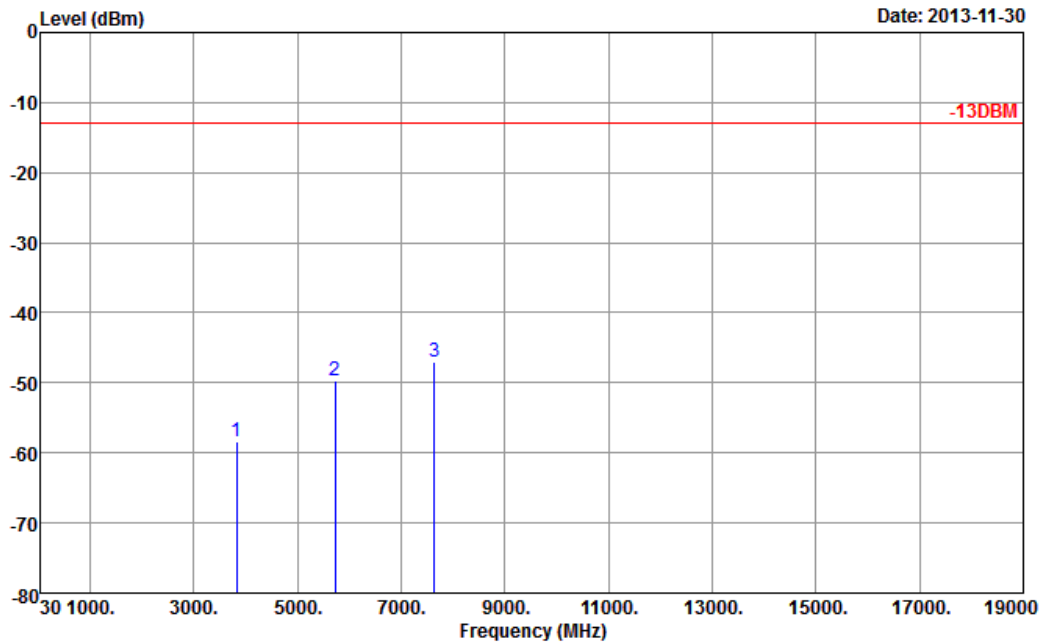

Site : 03CH01-SZ
 Condition : -13DBM HF_EIRP_H_130101 HORIZONTAL
 Project : (FG) 3N2607

| Frequency (MHz) | EIRP (dBm) | Limit (dBm) | Over Limit (dB) | SPA Reading (dBm) | S.G. Power (dBm) | TX Cable loss (dB) | TX Antenna Gain (dBi) | Polarization (H/V) | Result |
|-------------------|--------------|---------------|-------------------|---------------------|--------------------|----------------------|-------------------------|----------------------|--------|
| 3819.6 | -58.32 | -13 | -45.32 | -69.89 | -65.09 | 1.23 | 8.00 | H | Pass |
| 5729.4 | -49.63 | -13 | -36.63 | -67.43 | -57.76 | 1.52 | 9.65 | H | Pass |
| 7639.2 | -47.01 | -13 | -34.01 | -69.25 | -57.19 | 1.82 | 12.00 | H | Pass |



| | | | |
|------------------------|--|----------------------------|----------|
| Band : | GSM1900 for CH810 | Temperature : | 23~25°C |
| Test Mode : | GSM Link (GMSK) | Relative Humidity : | 48~52% |
| Test Engineer : | Gavin Zhang | Polarization : | Vertical |
| Remark : | Spurious emissions within 30-1000MHz were found more than 20dB below limit line. | | |

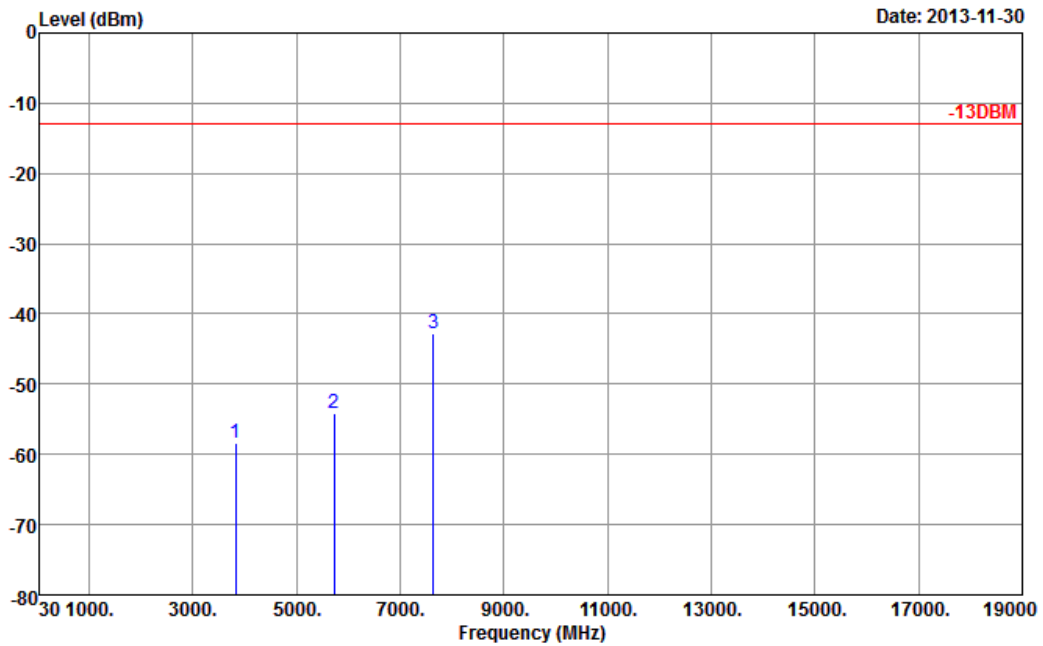

Site : 03CH01-SZ
 Condition : -13DBM HF_EIRP_V_130101 VERTICAL
 Project : (FG) 3N2607

| Frequency (MHz) | EIRP (dBm) | Limit (dBm) | Over Limit (dB) | SPA Reading (dBm) | S.G. Power (dBm) | TX Cable loss (dB) | TX Antenna Gain (dBi) | Polarization (H/V) | Result |
|-------------------|--------------|---------------|-------------------|---------------------|--------------------|----------------------|-------------------------|----------------------|--------|
| 3819.6 | -58.48 | -13 | -45.48 | -72.93 | -65.25 | 1.23 | 8 | V | Pass |
| 5729.4 | -54.24 | -13 | -41.24 | -71.13 | -62.37 | 1.52 | 9.65 | V | Pass |
| 7639.2 | -42.74 | -13 | -29.74 | -65.29 | -52.92 | 1.82 | 12 | V | Pass |

3.8 Frequency Stability Measurement

3.8.1 Description of Frequency Stability Measurement

The frequency stability shall be measured by variation of ambient temperature and variation of primary supply voltage to ensure that the fundamental emission stays within the authorized frequency block. The frequency stability of the transmitter shall be maintained within $\pm 0.00025\%$ ($\pm 2.5\text{ppm}$) of the center frequency.

3.8.2 Measuring Instruments

The measuring equipment is listed in the section 4 of this test report.

3.8.3 Test Procedures for Temperature Variation

1. The EUT was set up in the thermal chamber and connected with the base station.
2. With power OFF, the temperature was decreased to -30°C and the EUT was stabilized before testing. Power was applied and the maximum change in frequency was recorded within one minute.
3. With power OFF, the temperature was raised in 10°C step up to 50°C . The EUT was stabilized at each step for at least half an hour. Power was applied and the maximum frequency change was recorded within one minute.

3.8.4 Test Procedures for Voltage Variation

1. The EUT was placed in a temperature chamber at $25\pm 5^{\circ}\text{C}$ and connected with the base station.
2. The power supply voltage to the EUT was varied from BEP to 115% of the nominal value measured at the input to the EUT.
3. The variation in frequency was measured for the worst case.

3.8.5 Test Setup

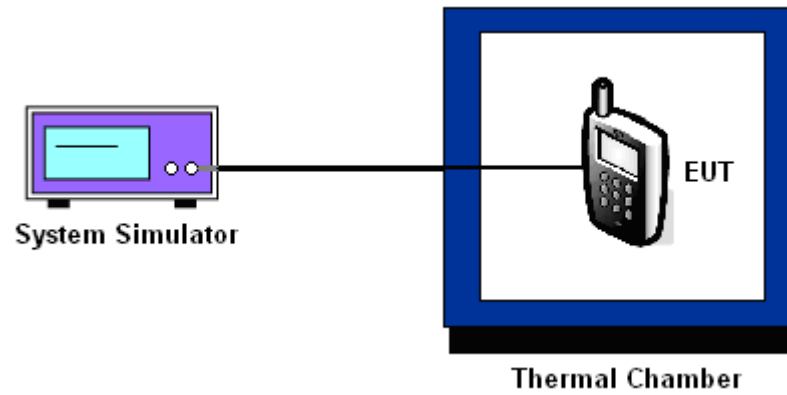

3.8.6 Test Result of Temperature Variation

<SIM1>

| | | | |
|----------------------|---------|--------------------|-----------|
| Band : | GSM 850 | Channel : | 189 |
| Limit (ppm) : | 2.5 | Frequency : | 836.4 MHz |

| Temperature (°C) | GSM | | Result |
|------------------|-----------------|-----------------|--------|
| | Freq. Dev. (Hz) | Deviation (ppm) | |
| -30 | -15 | -0.02 | PASS |
| -20 | -12 | -0.01 | |
| -10 | 9 | +0.01 | |
| 0 | 13 | +0.02 | |
| 10 | 10 | +0.01 | |
| 20 | -12 | -0.01 | |
| 30 | 13 | +0.02 | |
| 40 | 10 | +0.01 | |
| 50 | -11 | -0.01 | |

| | | | |
|----------------------|----------|--------------------|------------|
| Band : | GSM 1900 | Channel : | 661 |
| Limit (ppm) : | 2.5 | Frequency : | 1880.0 MHz |

| Temperature (°C) | GSM | | Result |
|------------------|-----------------|-----------------|--------|
| | Freq. Dev. (Hz) | Deviation (ppm) | |
| -30 | -24 | -0.01 | PASS |
| -20 | 21 | +0.01 | |
| -10 | -20 | -0.01 | |
| 0 | 19 | +0.01 | |
| 10 | 20 | +0.01 | |
| 20 | 21 | +0.01 | |
| 30 | 23 | +0.01 | |
| 40 | 22 | +0.01 | |
| 50 | 25 | +0.01 | |



<SIM2>

| | | | |
|---------------|---------|-------------|-----------|
| Band : | GSM 850 | Channel : | 189 |
| Limit (ppm) : | 2.5 | Frequency : | 836.4 MHz |

| Temperature (°C) | GSM | | Result |
|------------------|-----------------|-----------------|--------|
| | Freq. Dev. (Hz) | Deviation (ppm) | |
| -30 | -14 | -0.02 | PASS |
| -20 | -13 | -0.02 | |
| -10 | 15 | +0.02 | |
| 0 | 11 | +0.01 | |
| 10 | 10 | +0.01 | |
| 20 | -14 | -0.02 | |
| 30 | 11 | +0.01 | |
| 40 | -12 | -0.01 | |
| 50 | -13 | -0.02 | |

| | | | |
|---------------|----------|-------------|------------|
| Band : | GSM 1900 | Channel : | 661 |
| Limit (ppm) : | 2.5 | Frequency : | 1880.0 MHz |

| Temperature (°C) | GSM | | Result |
|------------------|-----------------|-----------------|--------|
| | Freq. Dev. (Hz) | Deviation (ppm) | |
| -30 | -22 | -0.01 | PASS |
| -20 | -17 | -0.01 | |
| -10 | -16 | -0.01 | |
| 0 | -19 | -0.01 | |
| 10 | -18 | -0.01 | |
| 20 | -19 | -0.01 | |
| 30 | -18 | -0.01 | |
| 40 | -20 | -0.01 | |
| 50 | -21 | -0.01 | |

3.8.7 Test Result of Voltage Variation

<SIM1>

| Band & Channel | Mode | Voltage (Volt) | Freq. Dev. (Hz) | Deviation (ppm) | Limit (ppm) | Result |
|-------------------|------|----------------|-----------------|-----------------|-------------|--------|
| GSM 850 CH189 | GSM | 3.8 | -12 | -0.01 | 2.5 | PASS |
| | | BEP | -14 | -0.02 | | |
| | | 4.35 | -13 | -0.02 | | |
| GSM 1900 CH661 | GSM | 3.8 | 21 | +0.01 | | |
| | | BEP | 18 | +0.01 | | |
| | | 4.35 | -20 | -0.01 | | |

<SIM2>

| Band & Channel | Mode | Voltage (Volt) | Freq. Dev. (Hz) | Deviation (ppm) | Limit (ppm) | Result |
|-------------------|------|----------------|-----------------|-----------------|-------------|--------|
| GSM 850 CH189 | GSM | 3.8 | -14 | -0.02 | 2.5 | PASS |
| | | BEP | -13 | -0.02 | | |
| | | 4.35 | -15 | -0.02 | | |
| GSM 1900 CH661 | GSM | 3.8 | -19 | -0.01 | | |
| | | BEP | -21 | -0.01 | | |
| | | 4.35 | -18 | -0.01 | | |

Note:

1. Normal Voltage = 3.8V.
2. Battery End Point (BEP) = 3.65 V.



4 List of Measuring Equipment

| Instrument | Manufacturer | Model No. | Serial No. | Characteristics | Calibration Date | Test Date | Due Date | Remark |
|---------------------------|----------------------|-----------|-----------------|---------------------------|------------------|---------------------------------|---------------|--------------------------|
| Spectrum Analyzer | R&S | FSP30 | 101400 | 9kHz~30GHz | Mar. 28, 2013 | Dec. 01, 2013~ Dec. 06, 2013 | Mar. 27, 2014 | Conducted (TH01-SZ) |
| Spectrum Analyzer | R&S | FSV30 | 100845 | 9kHz~30GHz | Dec. 04, 2013 | Dec. 01, 2013~ Dec. 06, 2013 | Dec. 03, 2014 | Conducted (TH01-SZ) |
| Power Meter | Anritsu | ML2495A | 1218010 | N/A | Mar. 28, 2013 | Dec. 01, 2013~ Dec. 06, 2013 | Mar. 27, 2014 | Conducted (TH01-SZ) |
| Power Sensor | Anritsu | MA2411B | 1207253 | N/A | Mar. 28, 2013 | Dec. 01, 2013~ Dec. 06, 2013 | Mar. 27, 2014 | Conducted (TH01-SZ) |
| Thermal Chamber | Hongzhan | LP-150U | HD20120425 | N/A | Mar. 28, 2013 | Dec. 01, 2013~ Dec. 06, 2013 | Mar. 27, 2014 | Conducted (TH01-SZ) |
| Spectrum Analyzer | Agilent Technologies | N9038A | MY52260185 | 20Hz~26.5GHz | Apr. 04, 2013 | Nov. 29, 2013~ Dec. 19, 2013 | Apr. 03, 2014 | Radiation (03CH01-SZ) |
| Bilog Antenna | SCHAFFNER | CBL6112B | 2614 | 30MHz~2GHz | Dec. 26, 2012 | Nov. 29, 2013~ Dec. 19, 2013 | Dec. 25, 2013 | Radiation (03CH01-SZ) |
| Double Ridge Horn Antenna | ETS Lindgren | 3117 | 00119436 | 1GHz~18GHz | Oct. 26, 2013 | Nov. 29, 2013~ Dec. 19, 2013 | Oct. 25, 2014 | Radiation (03CH01-SZ) |
| SHF-EHF-Horn | Schwarzbeck | BBHA9170 | BBHA91702 49 | 14GHz~40GHz | Nov. 22, 2013 | Nov. 29, 2013~ Dec. 19, 2013 | Nov. 21, 2014 | Radiation (03CH01-SZ) |
| Amplifier | ADVANTEST | BB525C | E9007003 | 9kHz~3000MHz GAIN 30db | Mar. 29, 2013 | Nov. 29, 2013~ Dec. 19, 2013 | Mar. 28, 2014 | Radiation (03CH01-SZ) |
| Amplifier | Yiai | AV3860B | 04030 | 2GHz~26.5GHz | Mar. 29, 2013 | Nov. 29, 2013~ Dec. 19, 2013 | Mar. 28, 2014 | Radiation (03CH01-SZ) |
| Turn Table | EM Electronice | EM 1000 | N/A | 0 ~ 360 degree | N/A | Nov. 29, 2013~ Dec. 19, 2013 | N/A | Radiation (03CH01-SZ) |
| Antenna Mast | EM Electronice | EM 1000 | N/A | 1 m - 4 m | N/A | Nov. 29, 2013~ Dec. 19, 2013 | N/A | Radiation (03CH01-SZ) |



5 Uncertainty of Evaluation

Uncertainty of Radiated Emission Measurement (30 MHz ~ 1000 MHz)

| | |
|---|------|
| Measuring Uncertainty for a Level of Confidence of 95% ($U = 2Uc(y)$) | 3.90 |
|---|------|