



# RADIO TEST REPORT

**Test Report No.: 33IE0012-HO-D**

**Applicant** : SAMSUNG ELECTRONICS CO., LTD.  
**Type of Equipment** : GSM/GPRS 850/1900 and WCDMA1900 Phone with BT v4.0(LE), 802.11b/g/n  
**Model No.** : GT-S6810E  
**Test standard** : FCC Part 24 Subpart E: 2008  
**FCC ID** : A3LGTS6810E  
**Test Result** : Complied

1. This test report shall not be reproduced in full or partial, without the written approval of UL Japan, Inc
2. The results in this report apply only to the sample tested.
3. This sample tested is in compliance with the above regulation.
4. The test results in this report are traceable to the national or international standards.
5. This test report must not be used by the customer to claim product certification, approval, or endorsement by NVLAP, NIST, or any agency of the Federal Government.

**Date of test:** April 15 to 18, 2013

**Representative test engineer:**   
Yutaka Yoshida  
Engineer of WiSE Japan,  
UL Verification Service

**Approved by:**   
Takahiro Hatakeda  
Leader of WiSE Japan,  
UL Verification Service

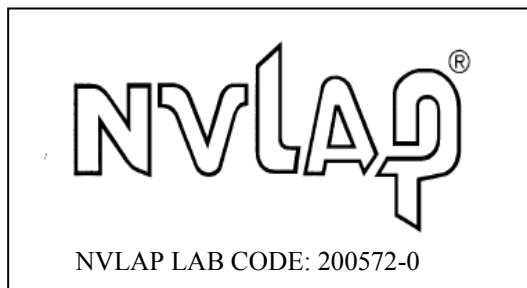

This laboratory is accredited by the NVLAP LAB CODE 200572-0, U.S.A. The tests reported herein have been performed in accordance with its terms of accreditation.  
\*As for the range of Accreditation in NVLAP, you may refer to the WEB address,  
<http://www.ul.com/japan/jpn/pages/services/emc/about/mark1/index.jsp#nvlap>



<b>CONTENTS</b>	<b>PAGE</b>
<b>SECTION 1: Customer information .....</b>	<b>4</b>
<b>SECTION 2: Equipment under test (E.U.T.) .....</b>	<b>4</b>
<b>SECTION 3: Test specification, procedures &amp; results .....</b>	<b>6</b>
<b>SECTION 4: Operation of E.U.T. during testing.....</b>	<b>9</b>
<b>SECTION 5: RF Output Power(Conducted/Radiated).....</b>	<b>15</b>
<b>SECTION 6: Bandwidth (Conducted) .....</b>	<b>16</b>
<b>SECTION 7: Spurious Emission and Band-Edge (Conducted/Radiated) .....</b>	<b>16</b>
<b>SECTION 8: Frequency Stability(Temperature/Voltage Variation).....</b>	<b>17</b>
<b>APPENDIX 1: Data of EMI test .....</b>	<b>18</b>
<b>RF Output Power (Conducted) .....</b>	<b>18</b>
<b>RF Output Power (Radiated) .....</b>	<b>20</b>
<b>Peak to Average power Ratio (Conducted) .....</b>	<b>21</b>
<b>Bandwidth(Conducted) .....</b>	<b>23</b>
<b>Band-Edge(Conducted).....</b>	<b>25</b>
<b>Band-Edge (Radiated).....</b>	<b>27</b>
<b>Spurious Emission (Conducted) .....</b>	<b>28</b>
<b>Spurious Emission (Radiated) .....</b>	<b>36</b>
<b>Frequency Stability (Temperature/Voltage Variation).....</b>	<b>38</b>
<b>APPENDIX 2: Test instruments .....</b>	<b>40</b>
<b>APPENDIX 3: Photographs of test setup.....</b>	<b>42</b>
<b>Radiated Spurious Emission.....</b>	<b>42</b>
<b>Worst Case Position (Horizontal: X-axis/ Vertical: Y-axis) .....</b>	<b>43</b>

---

**UL Japan, Inc.**

**Head Office EMC Lab.**

4383-326 Asama-cho, Ise-shi, Mie-ken 516-0021 JAPAN

Telephone : +81 596 24 8999

Facsimile : +81 596 24 8124

## **SECTION 1: Customer information**

Company Name : SAMSUNG ELECTRONICS CO., LTD.  
Address : 416, MAETAN 3-DONG, YEONGTONG-GU SUWON-CITY,  
GYEONGGI-DO 443-742, SOUTH KOREA

## **SECTION 2: Equipment under test (E.U.T.)**

### **2.1 Identification of E.U.T.**

Type of Equipment : GSM/GPRS 850/1900 and WCDMA1900 Phone with  
BT v4.0(LE), 802.11b/g/n  
Model No. : GT-S6810E  
Serial No. : Refer to Section 4, Clause 4.2  
Rating : AC100-240V/50-60Hz (AC Adapter)  
DC3.7V/1200mAh (Battery)  
Receipt Date of Sample : April 15, 2013  
Modification of EUT : No Modification by the test lab

---

**UL Japan, Inc.**

**Head Office EMC Lab.**

4383-326 Asama-cho, Ise-shi, Mie-ken 516-0021 JAPAN

Telephone : +81 596 24 8999

Facsimile : +81 596 24 8124

## 2.2 Product Description

### Radio Specification

#### **Bluetooth (BDR/EDR)**

Equipment Type	Transceiver
Frequency of Operation	2402-2480MHz
Type of Modulation	FHSS
Bandwidth & Channel spacing	1MHz & 1MHz
Antenna Type	FPCB Antenna
Antenna Gain	-1.41dBi

#### **Bluetooth (Low Energy)**

Equipment Type	Transceiver
Frequency of Operation	2402-2480MHz
Type of Modulation	DSSS
Bandwidth & Channel spacing	1MHz & 2MHz
Antenna Type	FPCB Antenna
Antenna Gain	-1.41dBi

#### **WLAN (IEEE802.11b/g/n-20)**

Equipment Type	Transceiver
Frequency of Operation	2412-2462MHz
Type of Modulation	DSSS, OFDM
Bandwidth & Channel spacing	20MHz & 5MHz
Antenna Type	FPCB Antenna
Antenna Gain	-1.41dBi

#### **GSM**

Equipment Type	Transceiver
Frequency of Operation	[Up Link] GSM850: 824 – 849MHz PCS: 1850 – 1910MHz [Down Link] GSM850: 869 – 894MHz PCS: 1930 – 1990MHz
Type of Modulation	GMSK
Emission Designator	GSM850: 250KGXW PCS: 250KGXW
Antenna Type	MID/PIFA internal Antenna
Antenna Gain	GSM850: -2.3dBi PCS: -2.3dBi

#### **W-CDMA**

Equipment Type	Transceiver
Frequency of Operation	[Up Link] Band II: 1850 – 1910MHz [Down Link] Band II: 1930 – 1990MHz
Type of Modulation	QPSK
Emission Designator	Band II: 4M15F9W
Antenna Type	MID/PIFA internal Antenna
Antenna Gain	Band II: -2.3dBi

## **UL Japan, Inc.**

### **Head Office EMC Lab.**

4383-326 Asama-cho, Ise-shi, Mie-ken 516-0021 JAPAN

Telephone : +81 596 24 8999

Facsimile : +81 596 24 8124

## **SECTION 3: Test specification, procedures & results**

### **3.1 Test Specification**

Test Specification : FCC Part 24 Subpart E: 2008, final revised on May 2, 2008  
Title : FCC 47CFR Part 24 Subpart E  
Broadband PCS

### **3.2 Procedures and results**

<b>Item</b>	<b>Test Specification &amp; Procedure</b>	<b>Remarks</b>	<b>Deviation</b>	<b>Worst margin</b>	<b>Results</b>
RF Output Power(Conducted/ Radiated) (Conducted Output Power / Equivalent isotropic radiated power(EIRP))	FCC 2.1046 FCC 24.232(c)	Conducted/ Radiated	N/A	-	Complied
Peak to Average power Ratio	FCC 24.232(d)	Conducted	N/A	-	Complied
Emission Bandwidth, 99% Occupied Bandwidth	FCC 2.1049 FCC 24.238	Conducted	N/A	-	Complied
Band-Edge	FCC 2.1051 FCC 2.1053 FCC 24.238	Conducted/ Radiated	N/A	<b>PCS</b> [Conducted] 4.28dB 1910.0184MHz [Radiated] 4.2dB 1910.02MHz Horizontal  <b>W-CDMA</b> [Conducted] 12.07dB 1910.0000MHz [Radiated] 10.0dB 1850.00MHz, Horizontal	Complied
Spurious Emission(Conducted)	FCC 2.1051 FCC 24.238	Conducted	N/A	-	Complied
Spurious Emission(Radiated)	FCC 2.1053 FCC 24.238	Radiated	N/A	<b>PCS</b> 29.7dB 5729.40MHz Horizontal  <b>W-CDMA</b> 30.6dB 7630.40MHz Horizontal	Complied
Frequency Stability (Temperature Variation)	FCC 2.1055(a)(1)(b) FCC 24.235	Conducted	N/A	-	Complied
Frequency Stability (Voltage Variation)	FCC 2.1055(d)(1)(2) FCC 24.235	Conducted	N/A	-	Complied

Note: UL Japan's EMI Work Procedures No. 13-EM-W0420

\*These tests were also referred to ANSI/TIA 603-C-2004 "Land Mobile FM or PM Communications Equipment Measurement and Performance Standards."

\*These tests were also referred to KDB 971168 D01 "Procedures for Compliance Measurement of the Fundamental Emission Power of Licensed Wideband (> 1 MHz) Digital Transmission Systems"

\*These tests were performed without any deviations from test procedure except for additions or exclusions.

**UL Japan, Inc.**

**Head Office EMC Lab.**

4383-326 Asama-cho, Ise-shi, Mie-ken 516-0021 JAPAN

Telephone : +81 596 24 8999

Facsimile : +81 596 24 8124

### 3.3 Uncertainty

#### EMI

The following uncertainties have been calculated to provide a confidence level of 95% using a coverage factor k=2.

Radiated Emission (EUT height: 0.8m) ( $\pm$ dB)	
Measurement Distance 3m	
30MHz-300MHz	5.5dB
300MHz-1000MHz	4.2dB
1GHz-12.75GHz	4.6dB
Measurement Distance 1m	
1GHz-18GHz	5.3dB
15GHz-26.5GHz	3.7dB
26.5GHz-40GHz	3.7dB

Power meter ( $\pm$ dB)	
Below 1GHz	Above 1GHz
0.7dB	1.5dB

Antenna terminal conducted emission and Power density ( $\pm$ dB)			Antenna terminal conducted emission ( $\pm$ dB)		Channel power ( $\pm$ dB)
Below 1GHz	1GHz-3GHz	3GHz-18GHz	18GHz-26.5GHz	26.5GHz-40GHz	
1.5dB	1.7dB	2.8dB	2.8dB	2.9dB	2.6dB

#### Antenna Terminal Conducted emission test

The data listed in this test report has enough margin, more than the site margin.

#### Radiated emission test(3m)

The data listed in this report meets the limits unless the uncertainty is taken into consideration.

**UL Japan, Inc.**

**Head Office EMC Lab.**

4383-326 Asama-cho, Ise-shi, Mie-ken 516-0021 JAPAN

Telephone : +81 596 24 8999

Facsimile : +81 596 24 8124

### 3.4 Test Location

UL Japan, Inc. Head Office EMC Lab. \*NVLAP Lab. code: 200572-0  
4383-326 Asama-cho, Ise-shi, Mie-ken 516-0021 JAPAN  
Telephone : +81 596 24 8999 Facsimile : +81 596 24 8124

	FCC Registration Number	IC Registration Number	Width x Depth x Height (m)	Size of reference ground plane (m) / horizontal conducting plane	Other rooms
No.1 semi-anechoic chamber	313583	2973C-1	19.2 x 11.2 x 7.7m	7.0 x 6.0m	No.1 Power source room
No.2 semi-anechoic chamber	655103	2973C-2	7.5 x 5.8 x 5.2m	4.0 x 4.0m	-
No.3 semi-anechoic chamber	148738	2973C-3	12.0 x 8.5 x 5.9m	6.8 x 5.75m	No.3 Preparation room
No.3 shielded room	-	-	4.0 x 6.0 x 2.7m	N/A	-
No.4 semi-anechoic chamber	134570	2973C-4	12.0 x 8.5 x 5.9m	6.8 x 5.75m	No.4 Preparation room
No.4 shielded room	-	-	4.0 x 6.0 x 2.7m	N/A	-
No.5 semi-anechoic chamber	-	-	6.0 x 6.0 x 3.9m	6.0 x 6.0m	-
No.6 shielded room	-	-	4.0 x 4.5 x 2.7m	4.75 x 5.4 m	-
No.6 measurement room	-	-	4.75 x 5.4 x 3.0m	4.75 x 4.15 m	-
No.7 shielded room	-	-	4.7 x 7.5 x 2.7m	4.7 x 7.5m	-
No.8 measurement room	-	-	3.1 x 5.0 x 2.7m	N/A	-
No.9 measurement room	-	-	8.0 x 4.5 x 2.8m	2.0 x 2.0m	-
No.10 measurement room	-	-	2.6 x 2.8 x 2.5m	2.4 x 2.4m	-
No.11 measurement room	-	-	3.1 x 3.4 x 3.0m	2.4 x 3.4m	-

\* Size of vertical conducting plane (for Conducted Emission test) : 2.0 x 2.0m for No.1, No.2, No.3, and No.4 semi-anechoic chambers and No.3 and No.4 shielded rooms.

### 3.5 Test set up, Test instruments and Data of EMI

Refer to APPENDIX.

## UL Japan, Inc.

### Head Office EMC Lab.

4383-326 Asama-cho, Ise-shi, Mie-ken 516-0021 JAPAN  
Telephone : +81 596 24 8999  
Facsimile : +81 596 24 8124

## SECTION 4: Operation of E.U.T. during testing

### 4.1 Operating Modes

#### <PCS1900>

Test	Operating mode	Power Control	Tested frequency	Channel
RF output Power (Conducted/Radiated)	Transmitting (Tx) (GSM, GMSK, 1slot) Transmitting (Tx) (GPRS, GMSK, 1-4slots, CS-1)	Max (PCL=0)	1850.2MHz 1880.0MHz 1909.8MHz	512 661 810
Peak to Average power Ratio (Conducted)	Transmitting (Tx) (GSM, GMSK, 1slot) Transmitting (Tx) (GPRS, GMSK, 1slot, CS-1)	Max (PCL=0)	1850.2MHz 1880.0MHz 1909.8MHz	512 661 810
Emission Bandwidth, 99% Occupied bandwidth	Transmitting (Tx) (GSM, GMSK, 1slot, CS-1) *1)	Max (PCL=0)	1880.0MHz	661
Band Edge (Conducted)	Transmitting (Tx) (GSM, GMSK, 1slot) *1)	Max (PCL=0)	1850.2MHz 1909.8MHz	512 810
Band Edge (Radiated)	Transmitting (Tx) (GSM, GMSK, 1slot) *1)	Max (PCL=0)	1850.2MHz 1909.8MHz	512 810
Spurious Emission (Conducted)	Transmitting (Tx) (GSM, GMSK, 1slot)	Max (PCL=0)	1850.2MHz 1880.0MHz 1909.8MHz	512 661 810
Spurious Emission(Radiated)	Transmitting (Tx) (GSM, GMSK, 1slot) *1)	Max (PCL=0)	1850.2MHz 1880.0MHz 1909.8MHz	512 661 810
Frequency Stability (Temperature/Voltage Variation)	Transmitting (Tx) (GSM, GMSK, 1slot) *1)	Max (PCL=0)	1880.0MHz	661

[GPRS]

\*Single slot (1 slot) which had the highest frame power was tested as a representative.

\*1) The mode was used for testing as a representative, because it had the highest RF output Power (Conducted).

#### <W-CDMA Band II>

Test	Operating mode	Power Control	Tested frequency	Channel
RF output Power(Conducted)	Transmitting (Tx) W-CDMA (RMC12.2kbps) Transmitting (Tx) W-CDMA (AMR) Transmitting (Tx) W-CDMA (HSDPA Subtest 1-4) Transmitting (Tx) W-CDMA (HSUPA Subtest 1-5)	See Section 4.1.1	1852.4 MHz 1880.0 MHz 1907.6 MHz	9262 9400 9538
RF output Power (Radiated), Spurious Emission (Conducted/Radiated), Peak to Average power Ratio (Conducted)	Transmitting (Tx) W-CDMA (RMC12.2kbps) *1)	TPC All Up Bits(Max)	1852.4 MHz 1880.0 MHz 1907.6 MHz	9262 9400 9538
Band Edge (Conducted/Radiated)	Transmitting (Tx) W-CDMA (RMC12.2kbps) *1)	TPC All Up Bits(Max)	1852.4 MHz 1907.6 MHz	9262 9538
Emission Bandwidth, 99% Occupied bandwidth, Frequency Stability (Temperature/Voltage Variation)	Transmitting (Tx) W-CDMA (RMC12.2kbps) *1)	TPC All Up Bits(Max)	1880.0 MHz	9400

\*The WCDMA and HSPA modes of EUT were verified on each channel and "sub-tests" according to section 4.1.1. (Also refer to Release-6 procedures in section 5.2 of 3GPP TS 34.121.)

\*1) The mode was used for testing as a representative, because it had the highest RF output Power (Conducted).

**UL Japan, Inc.**

**Head Office EMC Lab.**

4383-326 Asama-cho, Ise-shi, Mie-ken 516-0021 JAPAN

Telephone : +81 596 24 8999

Facsimile : +81 596 24 8124

#### 4.1.1 Explanation of the Rel-99 WCDMA and Rel-6 HSPA measurement mode

3GPP defines UE Test Modes and Channel Configurations for Regulatory Testing.

- **UE Test Modes:**  
Test Mode 1(Data Loopback Test)
- **Channel Configurations:**  
R99 – 12.2kpbs Reference Measurement Channel (RMC) channel  
HSDPA – Fixed Reference Channel (FRC)  
HSUPA – New HSUPA channel configuration (HSDPA data from DL is looped back onto UL)
- **Procedure to configure UE to transmit maximum power:**  
Rel99: 3GPP TS 34.121 section 5.2  
HSDPA Rel5: 3GPP TS 34.121 section 5.2A  
HSDPA Rel6: 3GPP TS 34.121 section 5.2AA  
HSUPA Rel6: 3GPP TS 34.121 section 5.2B

\* About Rel-99 and HSDPA testing, test equipment send “all up bits” forcing UE max power

#### (1) Explanation for HSDPA/HSPA Subtests

3GPP TS 34.121 defines test requirements and procedures for testing all variations of WCDMA. 3GPP TS 34.121 defines 4 HSDPA test configurations and 5 HSPA test configurations (“Subtests”) for various RF Conformance tests. The Following table shows Release 5 HSDPA and Release 6 HSPA Subtest Configurations per 3GPP TS 34.121.

[HSDPA]

Table C.10.1.4:  $\beta$  values for transmitter characteristics tests with HS-DPCCH

Sub-test	$\beta_c$	$\beta_d$	$\beta_d$ (SF)	$\beta_c/\beta_d$	$\beta_{HS}$ (Note 1, Note 2)	CM (dB) (Note 3)	MPR (dB) (Note 3)
1	2/15	15/15	64	2/15	4/15	0.0	0.0
2	12/15	15/15	64	12/15	24/15	1.0	0.0
	(Note 4)	(Note 4)		(Note 4)			
3	15/15	8/15	64	15/8	30/15	1.5	0.5
4	15/15	4/15	64	15/4	30/15	1.5	0.5

Note 1:  $\Delta_{ACK}$ ,  $\Delta_{NACK}$  and  $\Delta_{CQI} = 30/15$  with  $\beta_{HS} = 30/15 * \beta_c$ .

Note 2: For the HS-DPCCH power mask requirement test in clause 5.2C, 5.7A, and the Error Vector Magnitude (EVM) with HS-DPCCH test in clause 5.13.1A, and HSDPA EVM with phase discontinuity in clause 5.13.1AA,  $\Delta_{ACK}$  and  $\Delta_{NACK} = 30/15$  with  $\beta_{HS} = 30/15 * \beta_c$ , and  $\Delta_{CQI} = 24/15$  with  $\beta_{HS} = 24/15 * \beta_c$ .

Note 3: CM = 1 for  $\beta_c/\beta_d = 12/15$ ,  $\beta_{HS}/\beta_c = 24/15$ . For all other combinations of DPDCH, DPCCH and HS-DPCCH the MPR is based on the relative CM difference. This is applicable for only UEs that support HSDPA in release 6 and later releases.

Note 4: For subtest 2 the  $\beta_c/\beta_d$  ratio of 12/15 for the TFC during the measurement period (TF1, TF0) is achieved by setting the signalled gain factors for the reference TFC (TF1, TF1) to  $\beta_c = 11/15$  and  $\beta_d = 15/15$ .

**UL Japan, Inc.**

**Head Office EMC Lab.**

4383-326 Asama-cho, Ise-shi, Mie-ken 516-0021 JAPAN

Telephone : +81 596 24 8999

Facsimile : +81 596 24 8124

[HSUPA]

Table C.11.1.3:  $\beta$  values for transmitter characteristics tests with HS-DPCCH and E-DCH

Sub-test	$\beta_c$	$\beta_d$	$\beta_d$ (SF)	$\beta_c/\beta_d$	$\beta_{HS}$ (Note 1)	$\beta_{oc}$	$\beta_{ed}$ (Note 5) (Note 6)	$\beta_{ed}$ (SF)	$\beta_{ed}$ (Codes)	CM (dB) (Note 2)	MPR (dB) (Note 2)	AG Index (Note 6)	E-TFCI
1	11/15 (Note 3)	15/15 (Note 3)	64	11/15 (Note 3)	22/15	209/225	1309/225	4	1	1.0	0.0	20	75
2	6/15	15/15	64	6/15	12/15	12/15	94/75	4	1	3.0	2.0	12	67
3	15/15	9/15	64	15/9	30/15	30/15	$\beta_{ed1}$ : 47/15 $\beta_{ed2}$ : 47/15	4	2	2.0	1.0	15	92
4	2/15	15/15	64	2/15	4/15	2/15	56/75	4	1	3.0	2.0	17	71
5	15/15 (Note 4)	15/15 (Note 4)	64	15/15 (Note 4)	30/15	24/15	134/15	4	1	1.0	0.0	21	81

Note 1:  $\Delta_{ACK}$ ,  $\Delta_{NACK}$  and  $\Delta_{CQI} = 30/15$  with  $\beta_{hs} = 30/15 * \beta_c$ .

Note 2: CM = 1 for  $\beta_c/\beta_d = 12/15$ ,  $\beta_{hs}/\beta_c = 24/15$ . For all other combinations of DPDCH, DPCCH, HS-DPCCH, E-DPDCH and E-DPCCH the MPR is based on the relative CM difference.

Note 3: For subtest 1 the  $\beta_c/\beta_d$  ratio of 11/15 for the TFC during the measurement period (TF1, TF0) is achieved by setting the signalled gain factors for the reference TFC (TF1, TF1) to  $\beta_c = 10/15$  and  $\beta_d = 15/15$ .

Note 4: For subtest 5 the  $\beta_c/\beta_d$  ratio of 15/15 for the TFC during the measurement period (TF1, TF0) is achieved by setting the signalled gain factors for the reference TFC (TF1, TF1) to  $\beta_c = 14/15$  and  $\beta_d = 15/15$ .

Note 5: In case of testing by UE using E-DPDCH Physical Layer category 1, Sub-test 3 is omitted according to TS25.306 Table 5.1g.

Note 6:  $\beta_d$  can not be set directly, it is set by Absolute Grant Value.

## (2) Maximum Output Power Verification

[HSDPA]

Maximum output power was verified on High, Middle and Low channels according to the Release 5 procedures described in section 5.2 of 3GPP TS 34.121, using an FRC with H-set 1 and 12.2kbps RMC with TPC (transmit power control) set to all "1's". Output power was measured according requirements for HS-DPCCH Sub-test 1-4.

[HSUPA]

Maximum output power was verified on the High, Middle and Low channels according to Release 6 procedures in section 5.2 of 3GPP TS 34.121, using the appropriate RMC, FRC and E-DCH configurations. When E-DCH was active, inner loop power control with power control algorithm 2 was used to maintain E-TFCI requirements. Output power for the applicable HSPA modes was measured for E-DCH Sub-test 1-5.

**UL Japan, Inc.**

**Head Office EMC Lab.**

4383-326 Asama-cho, Ise-shi, Mie-ken 516-0021 JAPAN

Telephone : +81 596 24 8999

Facsimile : +81 596 24 8124

**(3) Test Equipment Setting Summary Table**

The following table is the key parameters that was configured in test equipment.

Subtest	Mode	Loopback Mode	Rel99 RMC	HSDPA FRC	HSUPA Test	Common Setting		$\beta_c/\beta_d$	MPR	Power Class 3 limit
						$\beta_c$	$\beta_d$			
	Rel99	Test Mode 1	12.2kbps RMC	-	-	-	-	8/15	-	24(+1.7/-3.7dB)
1	Rel6 HSDPA	Test Mode 1	12.2kbps RMC	H-Set 1 (QPSK)	-	2/15	15/15	2/15	0	24(+1.7/-3.7dB)
2	Rel6 HSDPA	Test Mode 1	12.2kbps RMC	H-Set 1 (QPSK)	-	12/15	15/15	12/15	0	24(+1.7/-3.7dB)
3	Rel6 HSDPA	Test Mode 1	12.2kbps RMC	H-Set 1 (QPSK)	-	15/15	8/15	15/8	0.5	23.5(+2.2/-3.7dB)
4	Rel6 HSDPA	Test Mode 1	12.2kbps RMC	H-Set 1 (QPSK)	-	15/15	4/15	15/4	0.5	23.5(+2.2/-3.7dB)
1	Rel6 HSUPA	Test Mode 1	12.2kbps RMC	H-Set 1 (QPSK)	HSUPA Loopback	11/15	15/15	11/15	0	24(+1.7/-3.7dB)
2	Rel6 HSUPA	Test Mode 1	12.2kbps RMC	H-Set 1 (QPSK)	HSUPA Loopback	6/15	15/15	6/15	2	22(+3.7/-3.7dB)
3	Rel6 HSUPA	Test Mode 1	12.2kbps RMC	H-Set 1 (QPSK)	HSUPA Loopback	15/15	9/15	15/9	1	23(+2.7/-3.7dB)
4	Rel6 HSUPA	Test Mode 1	12.2kbps RMC	H-Set 1 (QPSK)	HSUPA Loopback	2/15	15/15	2/15	2	22(+3.7/-3.7dB)
5	Rel6 HSUPA	Test Mode 1	12.2kbps RMC	H-Set 1 (QPSK)	HSUPA Loopback	15/15	15/15	15/15	0	24(+1.7/-3.7dB)

Subtest	HSDPA Specific Settings						
	$\Delta$ ACK	$\Delta$ NACK	$\Delta$ CQI	Ack-Nack repetition factor	CQI Feedback	CQI Repetition Factor	Ahs= $\beta$ hs/ $\beta$ c
Rel 6 HSDPA							
1	8	8	8	3	4ms	2	30/15
2	8	8	8	3	4ms	2	30/15
3	8	8	8	3	4ms	2	30/15
4	8	8	8	3	4ms	2	30/15

Subtest	HSDPA Specific Settings							HSUPA Specific Settings			HSUPA Additional Info	
	$\Delta$ ACK	$\Delta$ NACK	$\Delta$ CQI	Ack-Nack repetition factor	CQI Feedback	CQI Repetition Factor	Ahs= $\beta$ hs/ $\beta$ c	$\Delta$ E-DPCCH	$\Delta$ HARQ	AG Index	ETFCI (form TS34.121 Table C.11.1.3)	Associated Max UL Data Rate kbps
Rel 6 HSPA												
1	8	8	8	3	4ms	2	30/15	6	0	20	75	242.1
2	8	8	8	3	4ms	2	30/15	8	0	12	67	174.9
3	8	8	8	3	4ms	2	30/15	8	0	15	92	482.8
4	8	8	8	3	4ms	2	30/15	5	0	17	71	205.8
5	8	8	8	3	4ms	2	30/15	7	0	21	81	308.9

**UL Japan, Inc.**

**Head Office EMC Lab.**

4383-326 Asama-cho, Ise-shi, Mie-ken 516-0021 JAPAN

Telephone : +81 596 24 8999

Facsimile : +81 596 24 8124

HSUPA Reference E-TFCI Parameters  
 [Subtest 1, 2, 4, 5]

Information Element	Value/Remark
E-DCH info	Uplink DPCH info
- E-DPDCH info	
- Reference E-TFCIs	5 E-TFCIs
- Reference E-TFCI	11
- Reference E-TFCI PO	4
- Reference E-TFCI	67
- Reference E-TFCI PO	18
- Reference E-TFCI	71
- Reference E-TFCI PO	23
- Reference E-TFCI	75
- Reference E-TFCI PO	26
- Reference E-TFCI	81
- Reference E-TFCI PO	27

[Subtest 3]

Information Element	Value/Remark
E-DCH info	Uplink DPCH info
- E-DPDCH info	
- Reference E-TFCIs	2 E-TFCIs
- Reference E-TFCI	11
- Reference E-TFCI PO	4
- Reference E-TFCI	92
- Reference E-TFCI PO	18

---

**UL Japan, Inc.**

**Head Office EMC Lab.**

4383-326 Asama-cho, Ise-shi, Mie-ken 516-0021 JAPAN

Telephone : +81 596 24 8999

Facsimile : +81 596 24 8124

## 4.2 Configuration and peripherals

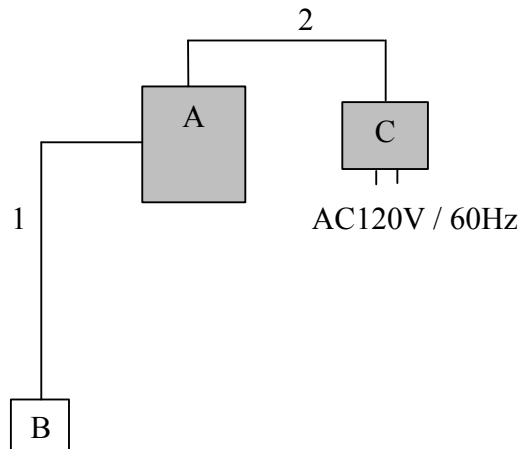

\* Cabling and setup(s) were taken into consideration and test data was taken under worse case conditions.

### Description of EUT and Support equipment

No.	Item	Model number	Serial number	Manufacturer	Remarks
A	GSM/GPRS 850/1900 and WCDMA1900 Phone with BT v4.0(LE), 802.11b/g/n	GT-S6810E	FK-095-D *1) FK-095-B *2)	SAMSUNG	EUT
B	Ear phone	-	-	SAMSUNG	-
C	AC Adaptor	ETAOU10EBE	DK2CB19TS17-E	SAMSUNG	EUT

\*1) Used for Antenna Terminal conducted test

\*2) Used for Radiated Emission test

### List of cables used

No.	Name	Length (m)	Shield		Remarks
			Cable	Connector	
1	Ear phone Cable	1.8	Shielded	Shielded	-
2	DC Cable	1.5	Unshielded	Unshielded	-

**UL Japan, Inc.**

**Head Office EMC Lab.**

4383-326 Asama-cho, Ise-shi, Mie-ken 516-0021 JAPAN

Telephone : +81 596 24 8999

Facsimile : +81 596 24 8124

## **SECTION 5: RF Output Power(Conducted/Radiated)**

[Conducted: Conducted Output Power]

### **Test Procedure**

The RF output power (conducted) was measured with Wireless Communication Test Set and an attenuator at the antenna port.

[Radiated: Equivalent isotropic radiated power(EIRP)]

### **Test Procedure**

- 1) EUT was placed on a urethane platform of nominal size, 0.5 m by 1.0m, raised 80cm above the conducting ground plane. Test was made with the antenna positioned in both the horizontal and vertical planes of polarization. The Radiated Electric Field Strength intensity has been measured in a semi anechoic chamber with a ground plane and at a distance of 3m. The measuring antenna height varied between 1 and 4m and EUT was rotated a full revolution in order to obtain the maximum value of the electric field intensity.
- 2) Exchanged the EUT to the Substitution Antenna, the measurement was set for the same height as the EUT. The frequency above 1GHz of the Substitution antenna was used with Horn antenna calibrated with the Half wave dipole antenna, which is harmonized with the measured frequency in 1). The Substitution Antenna was connected with the Signal Generator, and the polarized electromagnetic radiation of the Substitution Antenna was matched with the one of the measuring Antenna, which was set with the Signal Generator to the measured frequency in 1). Then, we set with the Output power (CW) of the Signal Generator where the measuring electromagnetic field is equal to the measured value in 1). The measuring antenna height varied between 1 and 4m to obtain the maximum receiving level. Its Output power of Signal Generator was recorded.
- 3) Equivalent isotropic radiated power(EIRP) was calculated by subtracting the cable loss and the attenuator loss connected between the Signal Generator and the Substitution Antenna from the Output power of the Signal Generator recorded in 2).

- The carrier level and noise levels were confirmed at each position of X, Y and Z axis of EUT to see the position of maximum noise, and the test was made at the position that has the maximum noise.

**Test data** : **APPENDIX 1**  
**Test result** : **Pass**

---

**UL Japan, Inc.**

**Head Office EMC Lab.**

4383-326 Asama-cho, Ise-shi, Mie-ken 516-0021 JAPAN

Telephone : +81 596 24 8999

Facsimile : +81 596 24 8124

## **SECTION 6: Bandwidth (Conducted)**

### **Test Procedure**

The Emission Bandwidth and 99% Occupied Bandwidth was measured with a spectrum analyzer and attenuator connected to the antenna port.

**Test data** : **APPENDIX 1**  
**Test result** : **Pass**

## **SECTION 7: Spurious Emission and Band-Edge (Conducted/Radiated)**

[Conducted]

### **Test Procedure**

The Spurious Emission and Band-Edge was measured with a spectrum analyzer and attenuator connected to the antenna port.

[Radiated]

### **Test Procedure**

- 1) EUT was placed on a urethane platform of nominal size, 0.5 m by 1.0m, raised 80cm above the conducting ground plane. Test was made with the antenna positioned in both the horizontal and vertical planes of polarization. The Radiated Electric Field Strength intensity has been measured in a semi anechoic chamber with a ground plane and at a distance of 3m. The measuring antenna height was varied between 1 to 4m and EUT was rotated a full revolution in order to obtain the maximum value of the electric field intensity.
- 2) Exchanged the EUT to the Substitution Antenna, the antenna was set for the same height as EUT on the table. The frequency below 1GHz of the Substitution antenna was used as the Half wave dipole antenna and Shorted dipole antenna calibrated with the Half wave dipole antenna, which is harmonized with the measured frequency in 1). The frequency above 1GHz of the Substitution antenna was used with Horn antenna calibrated with the Half wave dipole antenna. The Substitution antenna was connected with the Signal Generator, and the polarized electromagnetic radiation of the Substitution antenna was matched with the one of the measuring antenna, which was set with the Signal Generator to the measured frequency in 1). Then, we set with the Output power (CW) of the Signal Generator where the measuring electromagnetic field is equal to the measured value in 1). The measuring antenna height varied between 1 and 4m to obtain the maximum receiving level. Its Output power of Signal Generator was recorded.
- 3) Equivalent isotropic radiated power was calculated by subtracting the cable loss and the attenuator loss connected between the Signal Generator and the Substitution Antenna from the Output power of the Signal Generator recorded in 2).

- The carrier level and noise levels were confirmed at each position of X, Y and Z axis of EUT to see the position of maximum noise, and the test was made at the position that has the maximum noise.

**Test data** : **APPENDIX 1**  
**Test result** : **Pass**

---

**UL Japan, Inc.**

**Head Office EMC Lab.**

4383-326 Asama-cho, Ise-shi, Mie-ken 516-0021 JAPAN

Telephone : +81 596 24 8999

Facsimile : +81 596 24 8124

## **SECTION 8: Frequency Stability(Temperature/Voltage Variation)**

### **Test Procedure**

The Frequency Stability was measured with a Wireless Communication Test Set and attenuator connected to the antenna port.

The Frequency Drift was measured with the 10 deg. C steps from -30 deg. C to 50 deg. C, and it is presented as the ppm unit. The Frequency Drift was measured with the normal temperature (20 deg. C) and Voltage tolerance (DC 3.5V to DC 4.3V), and it is presented as the ppm unit.

Temperature : -30deg. C to +50deg. C (10 deg. C step)  
Voltage : Vnom:DC4.0V, Vmin:DC3.5V, Vmax:DC4.3V

As the operating input voltage of the EUT is between DC 3.5V to DC 4.3V (nominal voltage: DC 4.0V), Frequency Stability test was performed under the above condition.

**Test data** : **APPENDIX 1**  
**Test result** : **Pass**

---

**UL Japan, Inc.**

**Head Office EMC Lab.**

4383-326 Asama-cho, Ise-shi, Mie-ken 516-0021 JAPAN

Telephone : +81 596 24 8999

Facsimile : +81 596 24 8124

**APPENDIX 1: Data of EMI test**

**RF Output Power (Conducted)**  
**Conducted Output Power**  
**PCS1900**

Test place                   Head Office EMC Lab. No.6 Measurement Room  
Report No.                   33IE0012-HO  
Date                         04/18/2012  
Temperature/ Humidity     23deg.C / 54% RH  
Engineer                    Yutaka Yoshida  
Mode                         Tx GSM(GMSK), 1slot, PCL=0  
Mode                         Tx GPRS(GMSK), 1-4slots, CS-1, PCL=0

Mode		Ch	Frequency [MHz]	Average frame power		
				Reading [dBm]	Cable Loss [dB]	Result [dBm]
GSM	1slot	512	1850.2	22.09	6.66	28.75
		661	1880.0	22.33	6.66	28.99
		810	1909.8	22.18	6.67	28.85
GPRS (CS-1)	1slot	512	1850.2	22.08	6.66	28.74
		661	1880.0	22.33	6.66	28.99
		810	1909.8	22.17	6.67	28.84
	2slots	512	1850.2	19.52	6.66	26.18
		661	1880.0	19.83	6.66	26.49
		810	1909.8	19.71	6.67	26.38
	3slots	512	1850.2	17.44	6.66	24.10
		661	1880.0	17.80	6.66	24.46
		810	1909.8	17.72	6.67	24.39
	4slots	512	1850.2	16.37	6.66	23.03
		661	1880.0	16.81	6.66	23.47
		810	1909.8	16.68	6.67	23.35

Results = Reading + Cable Loss

**UL Japan, Inc.**

**Head Office EMC Lab.**

4383-326 Asama-cho, Ise-shi, Mie-ken 516-0021 JAPAN

Telephone : +81 596 24 8999

Facsimile : +81 596 24 8124

**RF Output Power (Conducted)**  
**Conducted Output Power**  
**W-CDMA Band II**

Test place Head Office EMC Lab. No.6 Measurement Room  
Report No. 33IE0012-HO  
Date 04/18/2013  
Temperature/ Humidity 23deg.C / 54% RH  
Engineer Yutaka Yoshida  
Mode Tx W-CDMA

Mode	Ch	Frequency [MHz]	Reading AVG [dBm]	Cable Loss [dB]	Result [dBm]
RMC 12.2kbps	Low	1852.4	21.44	0.45	21.89
	Mid	1880.0	21.39	0.45	21.84
	High	1907.6	21.31	0.45	21.76
AMR	Low	1852.4	21.32	0.45	21.77
	Mid	1880.0	21.20	0.45	21.65
	High	1907.6	21.26	0.45	21.71
HSDPA Subtest 1	Low	1852.4	21.28	0.45	21.73
	Mid	1880.0	21.19	0.45	21.64
	High	1907.6	21.05	0.45	21.50
HSDPA Subtest 2	Low	1852.4	21.21	0.45	21.66
	Mid	1880.0	21.16	0.45	21.61
	High	1907.6	21.03	0.45	21.48
HSDPA Subtest 3	Low	1852.4	21.17	0.45	21.62
	Mid	1880.0	21.09	0.45	21.54
	High	1907.6	21.03	0.45	21.48
HSDPA Subtest 4	Low	1852.4	21.18	0.45	21.63
	Mid	1880.0	21.09	0.45	21.54
	High	1907.6	21.03	0.45	21.48
HSUPA Subtest 1	Low	1852.4	20.63	0.45	21.08
	Mid	1880.0	20.63	0.45	21.08
	High	1907.6	20.58	0.45	21.03
HSUPA Subtest 2	Low	1852.4	17.64	0.45	18.09
	Mid	1880.0	17.67	0.45	18.12
	High	1907.6	17.73	0.45	18.18
HSUPA Subtest 3	Low	1852.4	18.75	0.45	19.20
	Mid	1880.0	18.59	0.45	19.04
	High	1907.6	18.73	0.45	19.18
HSUPA Subtest 4	Low	1852.4	17.71	0.45	18.16
	Mid	1880.0	17.56	0.45	18.01
	High	1907.6	17.69	0.45	18.14
HSUPA Subtest 5	Low	1852.4	21.11	0.45	21.56
	Mid	1880.0	21.38	0.45	21.83
	High	1907.6	21.24	0.45	21.69

Result = Reading + Cable loss

\*The enhanced power reduction may result in around 1dB of variance from the MPR target values depending on HSPA channel configuration (e.g. 34.121 subtest) and characteristics of hardware RF design.

**UL Japan, Inc.**

**Head Office EMC Lab.**

4383-326 Asama-cho, Ise-shi, Mie-ken 516-0021 JAPAN

Telephone : +81 596 24 8999

Facsimile : +81 596 24 8124

**RF Output Power (Radiated)**  
**Equivalent Isotropically Radiated Power(EIRP)**  
**PCS1900**

Test place : Head Office EMC Lab. No.2 Semi Anechoic Chamber  
Report No. : 33IE0012-HO  
Date : 04/15/2013  
Temperature / Humidity : 22deg. C / 42% RH  
Engineer : Tomohisa Nakagawa  
Mode : Tx GSM(GMSK), 1slot, PCL=0

Frequency [MHz]	Rx SA/TR Reading [dBuV]		Tx SG Reading [dBm]		Tx Cable Loss [dB]	Tx Ant. Gain [dBi]	Tx Ant. Atten. Loss [dB]	Result (EIRP) [dBm]		Limit (EIRP) [dBm]	Margin [dB]		Horizontal		Vertical		Remarks		
	HOR	VER	HOR	VER				HOR	VER		HOR	VER	HOR	VER	Rx Ant.	Turn		Rx Ant.	Turn
															Height [cm]	Table [deg.]		Height [cm]	Table [deg.]
1850.20	97.6	98.3	22.9	21.9	3.3	10.1	0.0	29.7	28.7	33.0	3.3	4.3	115	161	117	273			
1880.00	97.0	97.1	22.6	21.3	3.3	10.3	0.0	29.5	28.2	33.0	3.5	4.8	117	156	117	274			
1909.80	96.0	95.7	21.5	20.6	3.4	10.4	0.0	28.6	27.7	33.0	4.4	5.3	111	176	115	227			

Calculation Result = SG Reading - Tx Cable Loss + Tx Antenna Gain - Tx Antenna Attenuator Loss  
Rx-ANTENNA : Biconical Antenna(30M-300MHz), Logperiodic Antenna(300M-1000MHz), Horn Antenna(1G-40GHz)  
Tx-ANTENNA : 120MHz tuned Dipole Antenna(30M-120MHz), Dipole Antenna(120M-1000MHz), Horn Antenna(1G-40GHz)  
Detector : S/A PK(RBW:3MHz/VBW:8MHz)

**RF Output Power (Radiated)**  
**Equivalent Isotropically Radiated Power(EIRP)**  
**W-CDMA Band II**

Test place : Head Office EMC Lab. No.2 Semi Anechoic Chamber  
Report No. : 33IE0012-HO  
Date : 04/16/2013  
Temperature / Humidity : 24deg. C / 47% RH  
Engineer : Hironobu Ohnishi  
Mode : Tx W-CDMA (RMC12.2kbps), All Up Bits

Frequency [MHz]	Rx SA/TR Reading [dBuV]		Tx SG Reading [dBm]		Tx Cable Loss [dB]	Tx Ant. Gain [dBi]	Tx Ant. Atten. Loss [dB]	Result (EIRP) [dBm]		Limit (EIRP) [dBm]	Margin [dB]		Horizontal		Vertical		Remarks		
	HOR	VER	HOR	VER				HOR	VER		HOR	VER	HOR	VER	Rx Ant.	Turn		Rx Ant.	Turn
															Height [cm]	Table [deg.]		Height [cm]	Table [deg.]
1852.40	96.9	96.0	21.8	19.1	3.3	10.1	0.0	28.6	25.9	33.0	4.4	7.1	116	160	116	268			
1880.00	96.0	94.3	21.0	17.9	3.3	10.3	0.0	27.9	24.8	33.0	5.1	8.2	116	156	114	270			
1907.60	95.1	92.9	20.1	17.4	3.4	10.4	0.0	27.2	24.5	33.0	5.9	8.6	114	157	113	272			

Calculation Result = SG Reading - Tx Cable Loss + Tx Antenna Gain - Tx Antenna Attenuator Loss  
Rx-ANTENNA : Biconical Antenna(30M-300MHz), Logperiodic Antenna(300M-1000MHz), Horn Antenna(1G-40GHz)  
Tx-ANTENNA : 120MHz tuned Dipole Antenna(30M-120MHz), Dipole Antenna(120M-1000MHz), Horn Antenna(1G-40GHz)  
Detector : S/A PK(RBW:5MHz/VBW:50MHz)

### **Peak to Average power Ratio (Conducted)**

Report No. 33IE0012-HO  
Test place Head Office EMC Lab. No.6 Measurement Room  
Date 04/18/2013  
Temperature / Humidity 23deg. C / 54% RH  
Engineer Yutaka Yoshida  
Mode Tx GSM(GMSK), 1slot, PCL=0  
Tx GPRS(GMSK), 1slot, CS-1, PCL=0  
Tx W-CDMA(RMC12.2kbps), All Up Bits

Mode	Channel	Frequency [MHz]	Peak to Average power Ratio [dB]	Limit [dB]
GSM *1)	512	1850.20	0.005	13
	661	1880.00	0.011	13
	810	1909.80	0.004	13
GPRS *1)	512	1850.20	0.008	13
	661	1880.00	0.007	13
	810	1909.80	0.006	13
W-CDMA *2)	9262	1852.40	3.16	13
	9400	1880.00	3.08	13
	9538	1907.60	3.11	13

\*In order to decide the largest deviation between the average and the peak power of the EUT in a bandwidth,

\*1) an average and a peak trace of the spectrum analyzer was used for GSM Signals ;

\*2) Complementary Cumulative Distribution Function (CCDF) curves of the spectrum analyzer were used for W-CDMA Signals.

---

**UL Japan, Inc.**

**Head Office EMC Lab.**

4383-326 Asama-cho, Ise-shi, Mie-ken 516-0021 JAPAN

Telephone : +81 596 24 8999

Facsimile : +81 596 24 8124

**Peak to Average power Ratio (Conducted)**  
**W-CDMA Band II**

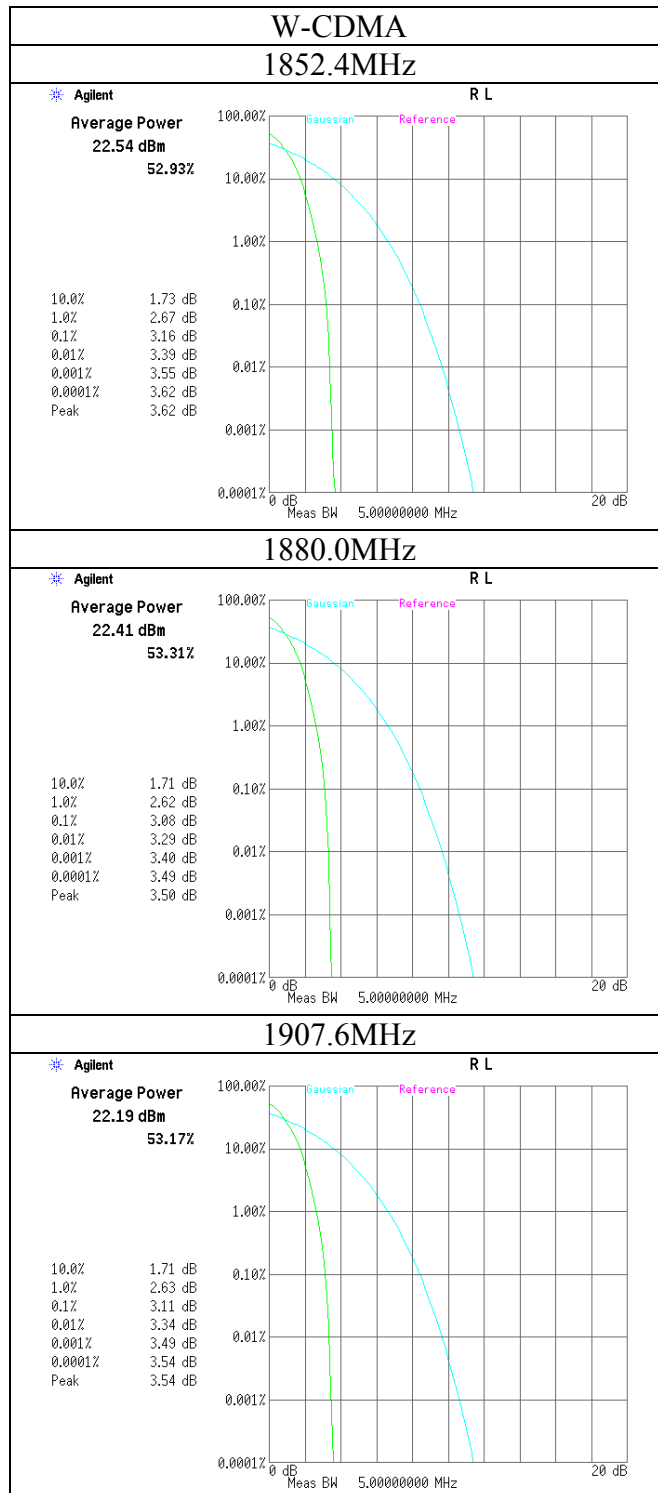

\*Set the spectrum analyzer radio mode to 3GPP WCDMA (CCDF)

**Bandwidth(Conducted)**  
**PCS1900**

Test place	33IE0012-HO
Report No.	Head Office EMC Lab. No.6 Measurement Room
Date	04/18/2013
Temperature/ Humidity	23deg. C / 54% RH
Engineer	Yutaka Yoshida
Mode	Tx GSM(GMSK), 1slot, PCL=0

CH	FREQ	26dB Bandwidth	99% OBW	Limit
	[MHz]	[kHz]	[kHz]	[kHz]
Mid	1880.0	337.750	249.7706	-

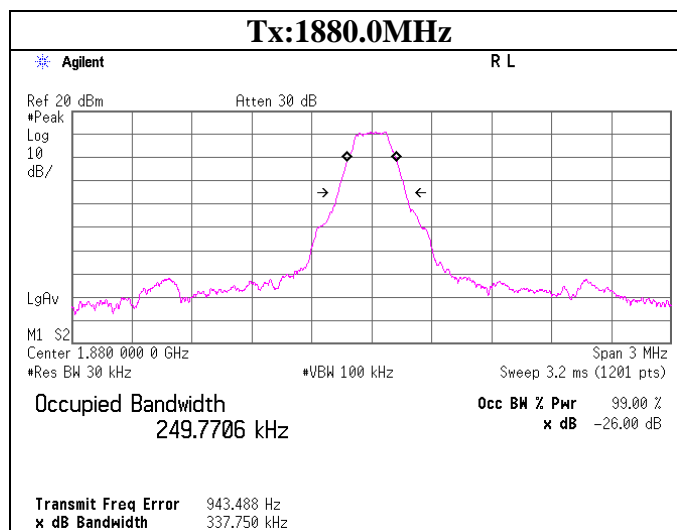

**Bandwidth(Conducted)**  
**W-CDMA Band II**

Test place	33IE0012-HO
Report No.	Head Office EMC Lab. No.6 Measurement Room
Date	04/18/2013
Temperature/ Humidity	23deg. C / 54% RH
Engineer	Yutaka Yoshida
Mode	Tx W-CDMA(RMC12.2kbps), All Up Bits

CH	FREQ [MHz]	26dB Bandwidth [MHz]	99% OBW [MHz]	Limit [kHz]
Mid	1880.0	4.747	4.1527	-

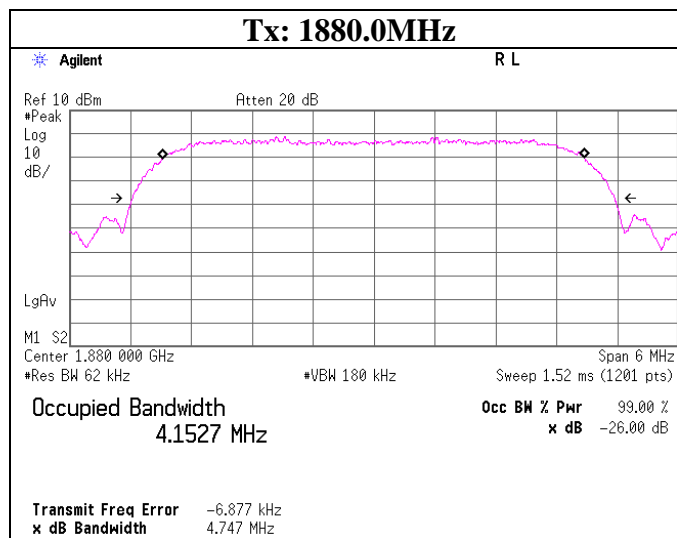

**Band-Edge(Conducted)**  
**PCS1900**

Test place	33IE0012-HO
Report No.	Head Office EMC Lab. No.6 Measurement Room
Date	04/18/2013
Temperature/ Humidity	23deg. C / 54% RH
Engineer	Yutaka Yoshida
Mode	Tx GSM(GMSK), 1slot, PCL=0

Frequency [MHz]	Reading [dBm]	Atten. [dB]	Cable Loss [dB]	Result [dBm]	Limit [dBm]	Margin [dB]
1849.9975	-37.25	10.03	7.85	-19.37	-13.0	6.37
1850.0000	-41.92	10.03	7.85	-24.04	-13.0	11.04
1910.0000	-42.18	10.03	7.88	-24.27	-13.0	11.27
1910.0184	-35.19	10.03	7.88	-17.28	-13.0	4.28

Power RMS Average 30 times

Sample Calculation : Result = Reading + Atten. + Cable Loss

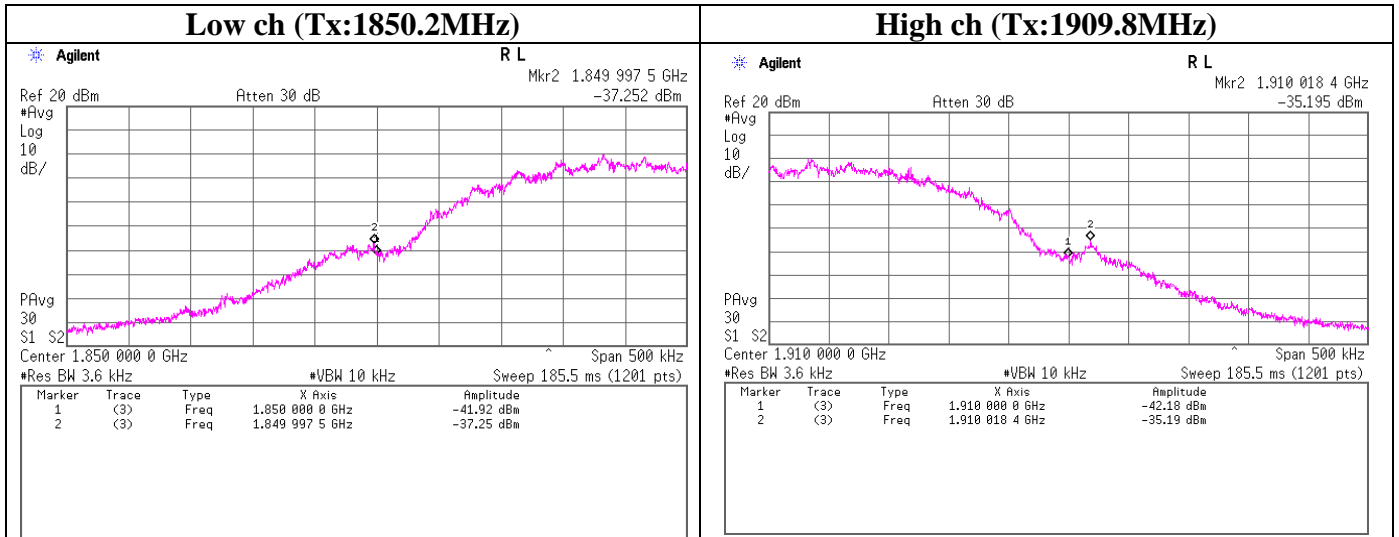

**UL Japan, Inc.**

**Head Office EMC Lab.**

4383-326 Asama-cho, Ise-shi, Mie-ken 516-0021 JAPAN

Telephone : +81 596 24 8999

Facsimile : +81 596 24 8124

**Band-Edge(Conducted)**  
**W-CDMA Band II**

Test place	33IE0012-HO
Report No.	Head Office EMC Lab. No.6 Measurement Room
Date	04/18/2013
Temperature/ Humidity	23deg. C / 54% RH
Engineer	Yutaka Yoshida
Mode	Tx W-CDMA(RMC12.2kps), All Up Bits

Frequency [MHz]	Reading [dBm]	Atten. [dB]	Cable Loss [dB]	Result [dBm]	Limit [dBm]	Margin [dB]
1850.0000	-43.57	10.03	7.85	-25.69	-13.0	12.69
1910.0000	-42.98	10.03	7.88	-25.07	-13.0	12.07

Power RMS Average 30 times

Sample Calculation : Result = Reading + Atten. + Cable Loss

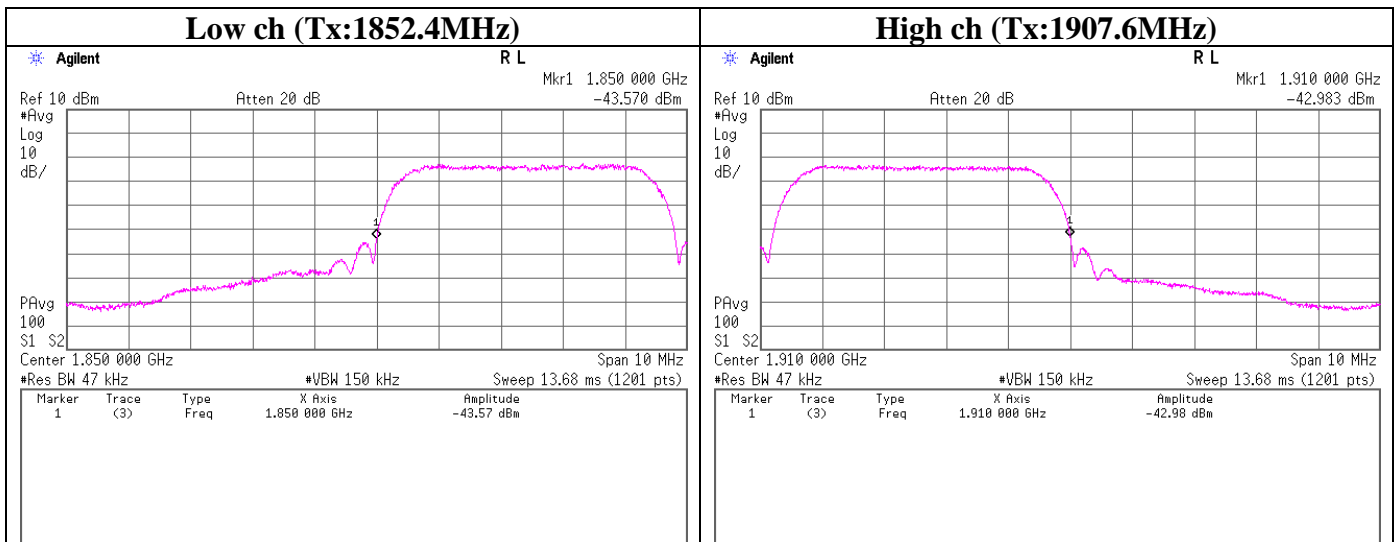

**UL Japan, Inc.**

**Head Office EMC Lab.**

4383-326 Asama-cho, Ise-shi, Mie-ken 516-0021 JAPAN

Telephone : +81 596 24 8999

Facsimile : +81 596 24 8124

**Band-Edge (Radiated)**  
**PCS1900**

Test place : Head Office EMC Lab. No.2 Semi Anechoic Chamber  
Report No. : 33IE0012-HO  
Date : 04/16/2013  
Temperature / Humidity : 24deg. C / 47% RH  
Engineer : Hironobu Ohnishi  
Mode : Tx GSM(GMSK), 1slot, PCL=0

Frequency [MHz]	Rx SA/TR Reading [dBuV]		Tx SG Reading [dBm]		Tx Cable Loss [dB]	Tx Ant. Gain [dBi]	Tx Ant. Atten. Loss [dB]	Result (EIRP) [dBm]		Limit (EIRP) [dBm]	Margin [dB]		Horizontal		Vertical		Remarks		
	HOR	VER	HOR	VER				HOR	VER		HOR	VER	HOR	VER	Rx Ant.	Turn		Rx Ant.	Turn
															Height	Table		Height	Table
1849.98	50.0	49.5	-24.9	-27.1	3.3	10.1	0.0	-18.1	-20.3	-13.0	5.1	7.3	115	161	117	273			
1850.00	46.9	43.4	-28.0	-33.3	3.3	10.1	0.0	-21.2	-26.5	-13.0	8.2	13.5	115	161	117	273			
1910.00	40.5	39.5	-34.1	-35.7	3.4	10.4	0.0	-27.0	-28.6	-13.0	14.0	15.6	111	176	115	227			
1910.02	50.3	49.0	-24.3	-26.2	3.4	10.4	0.0	-17.2	-19.1	-13.0	4.2	6.1	111	176	115	227			

Calculation Result = SG Reading - Tx Cable Loss + Tx Antenna Gain - Tx Antenna Attenuator Loss  
Rx-ANTENNA : Biconical Antenna(30M-300MHz), Logperiodic Antenna(300M-1000MHz), Horn Antenna(1G-40GHz)  
Tx-ANTENNA : 120MHz tuned Dipole Antenna(30M-120MHz), Dipole Antenna(120M-1000MHz), Horn Antenna(1G-40GHz)  
Other frequency noises omitted in this report were not seen or had enough margin (more than 20dB).  
Detector : S/A Average (Gate on) (RBW:3.6kHz/VBW:10kHz)

**Band Edge (Radiated)**  
**W-CDMA Band II**

Test place : Head Office EMC Lab. No.2 Semi Anechoic Chamber  
Report No. : 33IE0012-HO  
Date : 04/16/2013  
Temperature / Humidity : 24deg. C / 47% RH  
Engineer : Hironobu Ohnishi  
Mode : Tx W-CDMA (RMC12.2kbps), All Up Bits

Frequency [MHz]	Rx SA/TR Reading [dBuV]		Tx SG Reading [dBm]		Tx Cable Loss [dB]	Tx Ant. Gain [dBi]	Tx Ant. Atten. Loss [dB]	Result (EIRP) [dBm]		Limit (EIRP) [dBm]	Margin [dB]		Horizontal		Vertical		Remarks		
	HOR	VER	HOR	VER				HOR	VER		HOR	VER	HOR	VER	Rx Ant.	Turn		Rx Ant.	Turn
															Height	Table		Height	Table
1849.81	41.1	41.3	-33.8	-35.4	3.3	10.1	0.0	-27.0	-28.6	-13.0	14.0	15.6	116	160	116	268			
1850.00	45.1	44.3	-29.8	-32.4	3.3	10.1	0.0	-23.0	-25.6	-13.0	10.0	12.6	116	160	116	268			
1910.00	42.7	41.5	-31.9	-33.8	3.4	10.4	0.0	-24.8	-26.7	-13.0	11.8	13.7	114	157	113	272			
1910.18	40.5	37.7	-34.1	-37.6	3.4	10.4	0.0	-27.0	-30.5	-13.0	14.0	17.5	114	157	113	272			

Calculation Result = SG Reading - Tx Cable Loss + Tx Antenna Gain - Tx Antenna Attenuator Loss  
Rx-ANTENNA : Biconical Antenna(30M-300MHz), Logperiodic Antenna(300M-1000MHz), Horn Antenna(1G-40GHz)  
Tx-ANTENNA : 120MHz tuned Dipole Antenna(30M-120MHz), Dipole Antenna(120M-1000MHz), Horn Antenna(1G-40GHz)  
Other frequency noises omitted in this report were not seen or had enough margin (more than 20dB).  
Detector : S/A Average (RBW:47kHz/VBW:150kHz)

**Spurious Emission (Conducted)**  
**PCS1900**

Test place 33IE0012-HO  
Report No. Head Office EMC Lab. No.6 Measurement Room  
Date 04/18/2013  
Temperature/ Humidity 23deg. C / 54% RH  
Engineer Yutaka Yoshida  
Mode Tx GSM(GMSK), 1slot, PCL=0

**Limit Line**

Tx Frequency [MHz]	Limit [dBm]	Atten. [dB]	Cable Loss [dB]	Limit Line [dBm]
1850.2	-13.0	10.03	7.85	-30.9
1880.0	-13.0	10.03	7.86	-30.9
1909.8	-13.0	10.04	7.88	-30.9

Sample Calculation: Limit Line = Limit - Atten. - Cable Loss

**Spurious Emission (Conducted)**  
**GSM**  
**Tx:1850.2MHz**

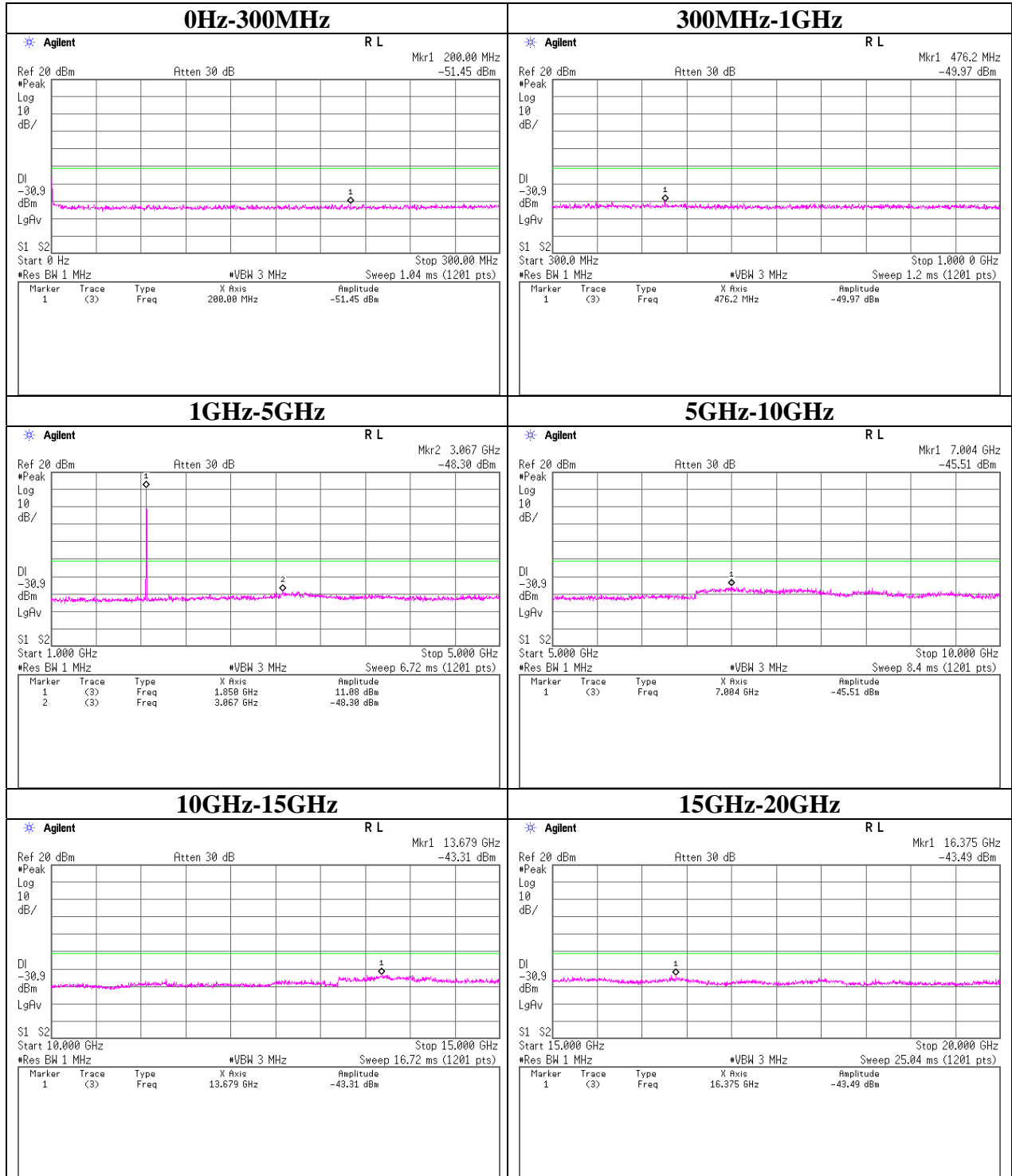

**Spurious Emission (Conducted)**  
**GSM**  
**Tx:1880.0MHz**

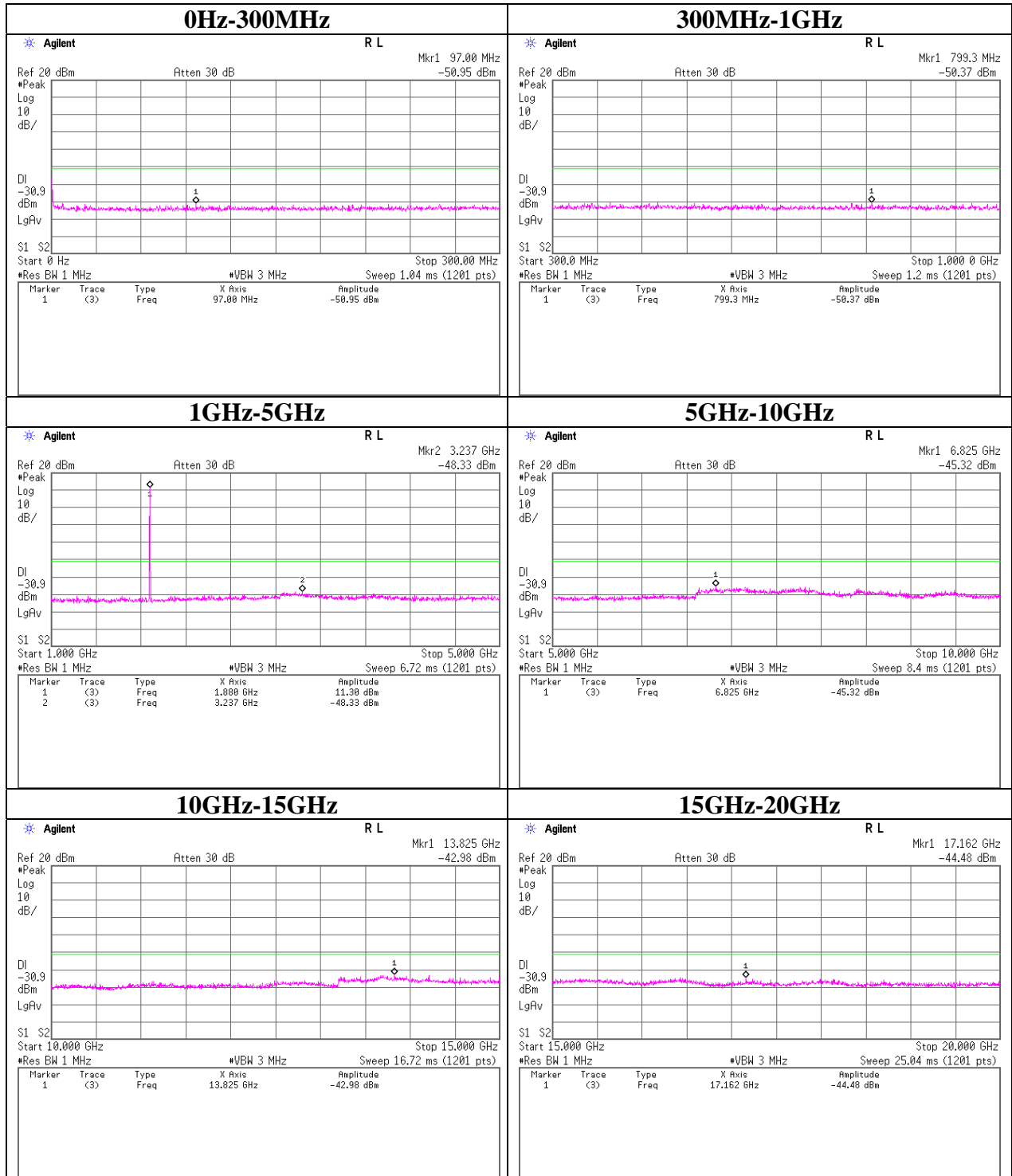

**Spurious Emission (Conducted)**  
**GSM**  
**Tx:1909.8MHz**

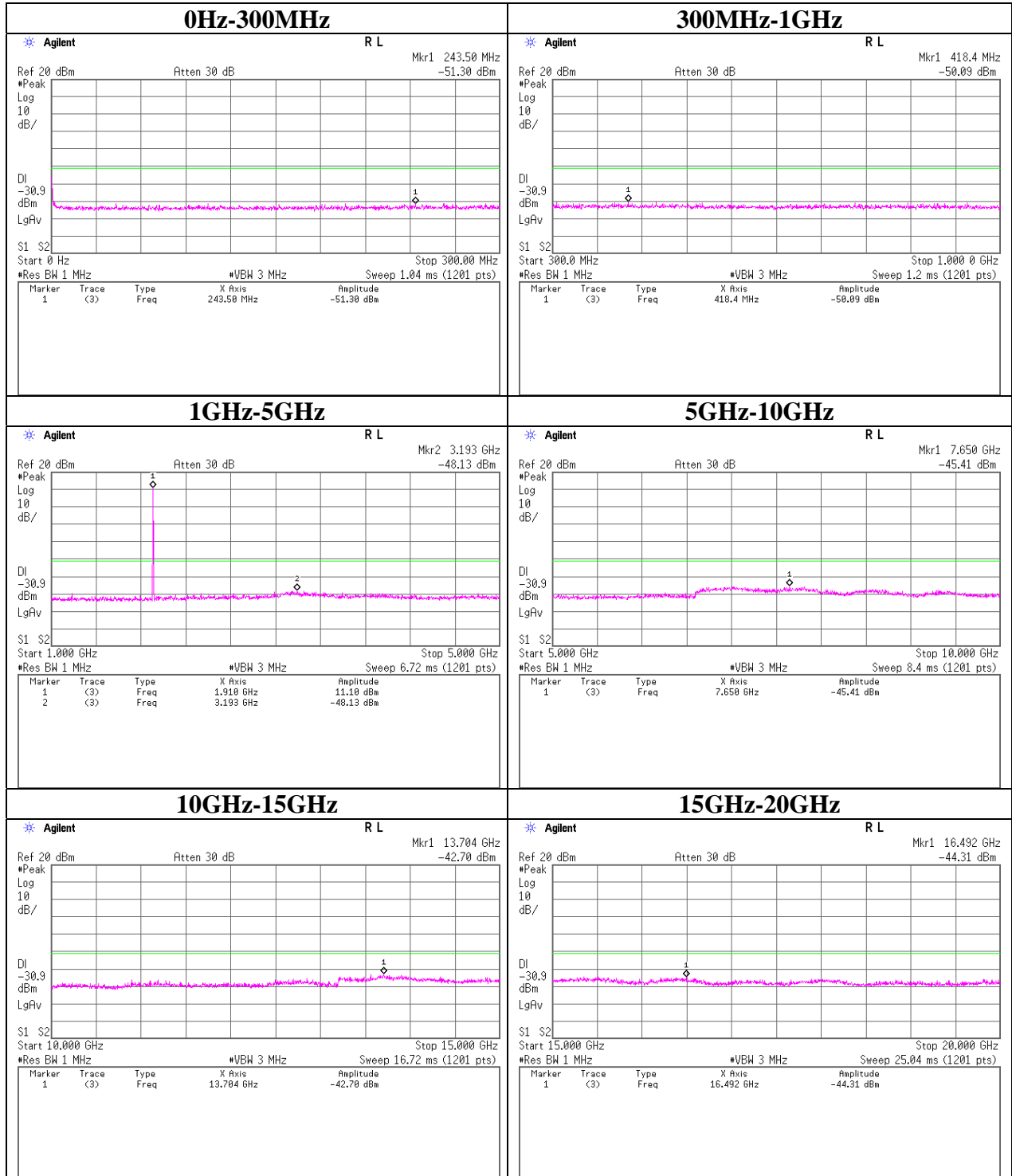

**Spurious Emission (Conducted)**  
**W-CDMA Band II**

Test place 33IE0012-HO  
Report No. Head Office EMC Lab. No.6 Measurement Room  
Date 04/18/2013  
Temperature/ Humidity 23deg. C / 54% RH  
Engineer Yutaka Yoshida  
Mode Tx W-CDMA(RMC12.2kbps), All Up Bits

**Limit Line**

Tx Frequency [MHz]	Limit [dBm]	Atten. [dB]	Cable Loss [dB]	Limit Line [dBm]
1852.4	-13.0	10.03	7.85	-30.9
1880.0	-13.0	10.03	7.86	-30.9
1907.6	-13.0	10.04	7.88	-30.9

Sample Calculation: Limit Line = Limit - Atten. - Cable Loss

**Spurious Emission (Conducted)**  
**W-CDMA Band II**  
**Tx:1852.4MHz**

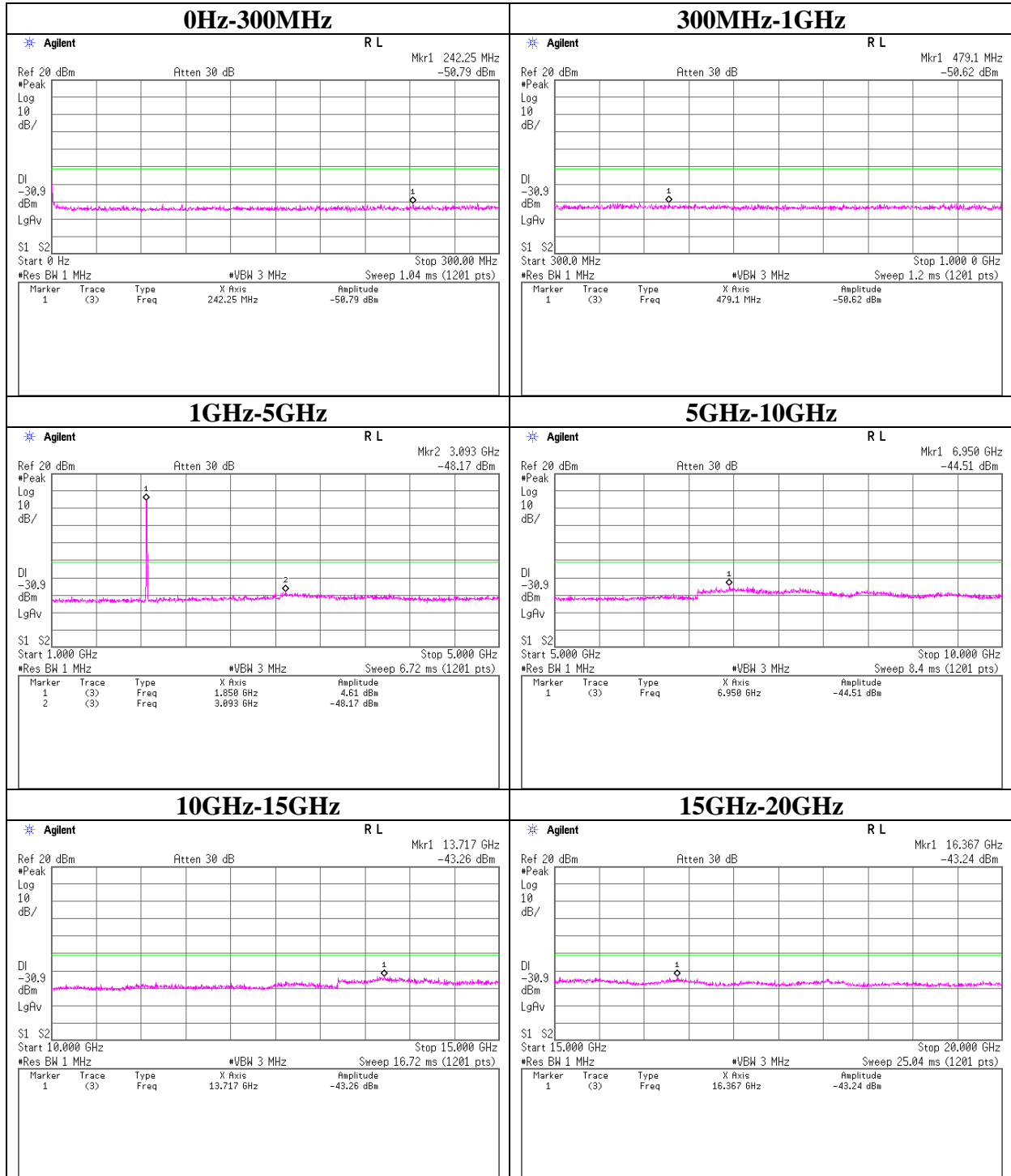

**Spurious Emission (Conducted)**  
**W-CDMA Band II**  
**Tx:1880.0MHz**

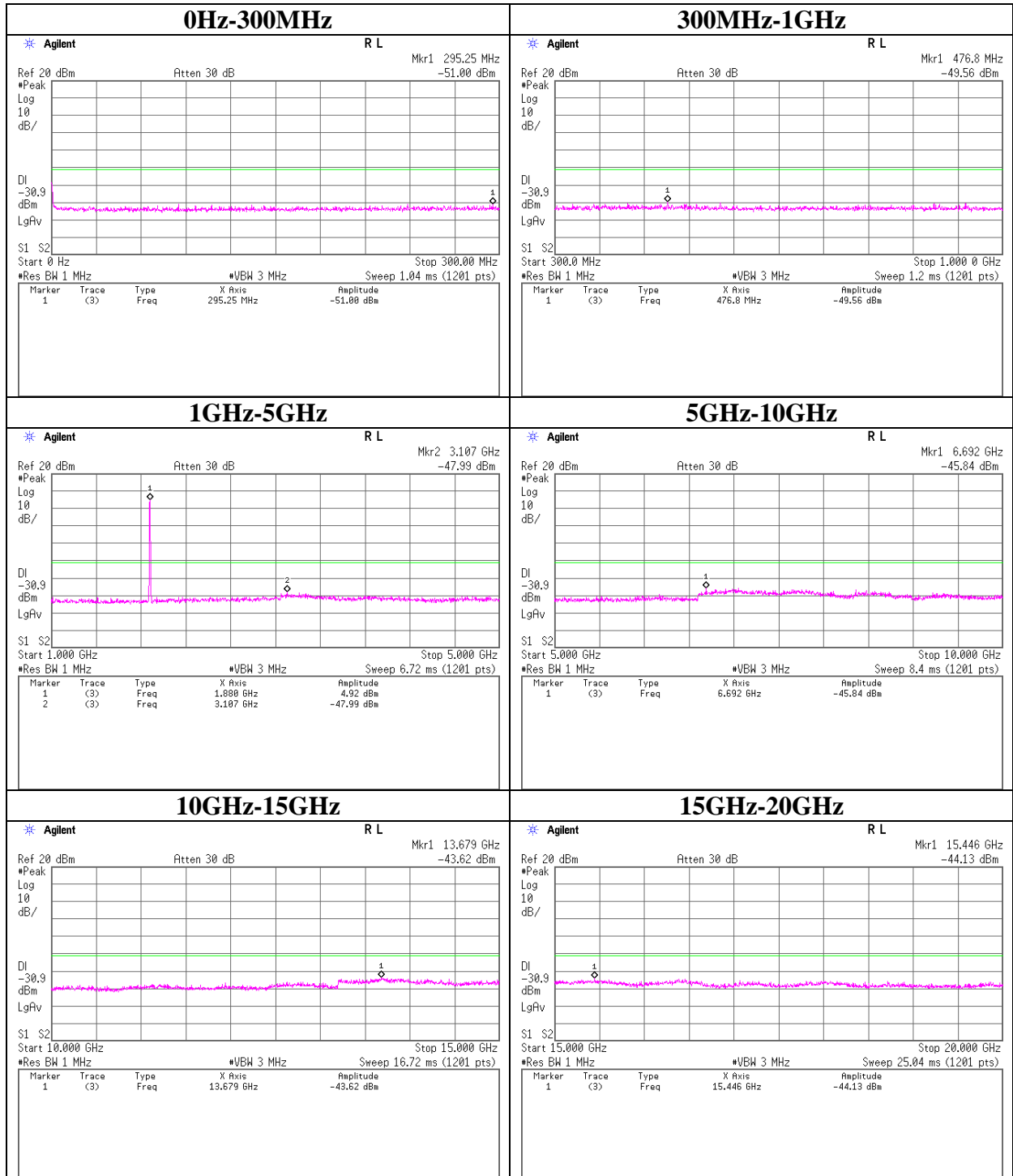

**Spurious Emission (Conducted)**  
**W-CDMA Band II**  
**Tx:1907.6MHz**

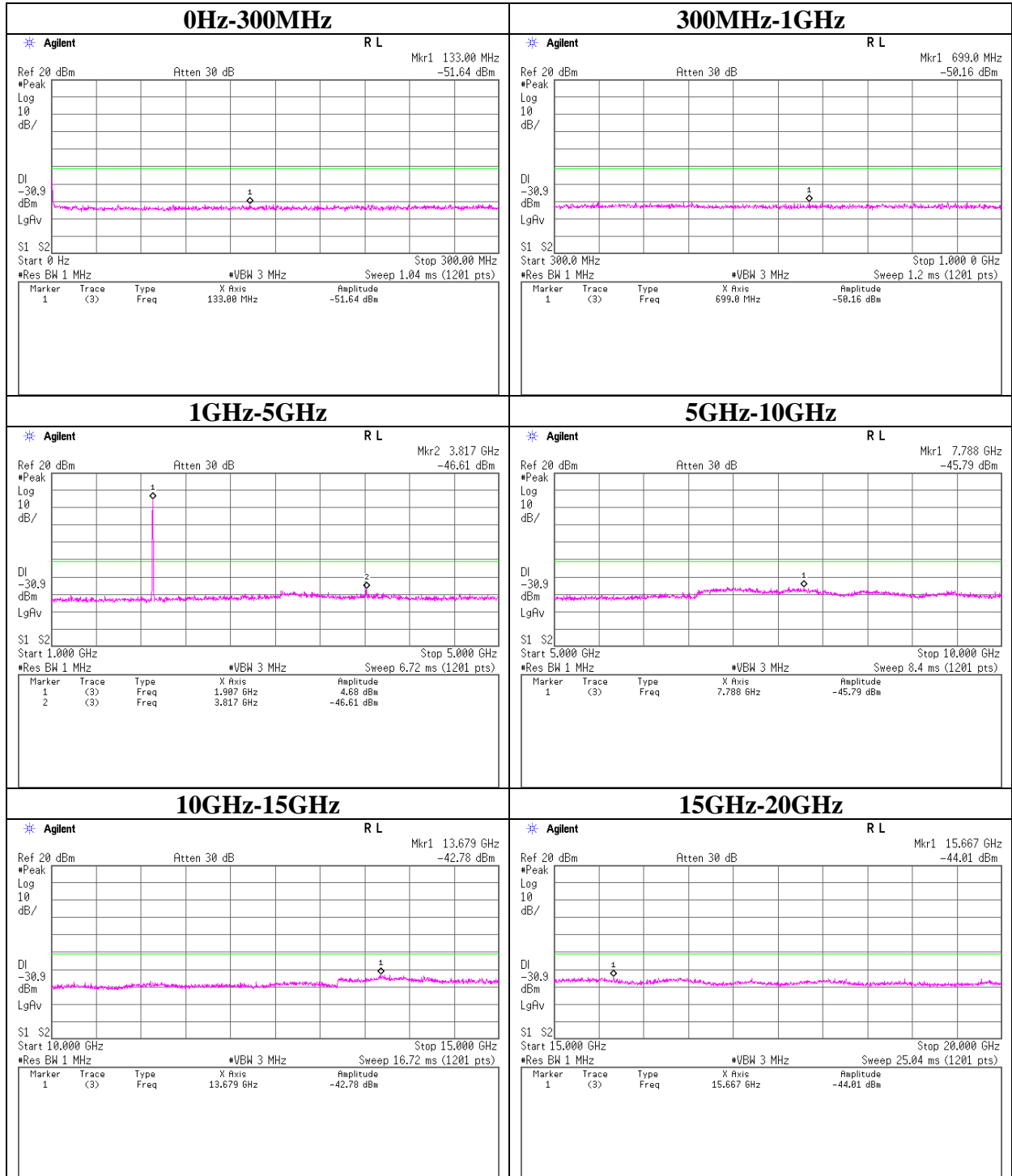

**Spurious Emission (Radiated)**  
**PCS1900**

Test place Head Office EMC Lab. No.4 and No.2 Semi Anechoic Chamber  
Report No. 33IE0012-HO  
Date 04/15/2013 04/16/2013 04/17/2013  
Temperature / Humidity 24deg. C / 32% RH 24deg. C / 47% RH 21deg. C / 41% RH  
Engineer Hironobu Ohnishi Hironobu Ohnishi Tomohisa Nakagawa  
(Below 1GHz) (1-10GHz) (Above 10GHz)  
Mode Tx GSM(GMSK), 1slot, PCL=0

**Tx 1850.2MHz**

Frequency [MHz]	Rx SA/TR Reading [dBuV]		Tx SG Reading [dBm]		Tx Cable Loss [dB]	Tx Ant. Gain [dBi]	Tx Ant. Atten. Loss [dB]	Result (EIRP) [dBm]		Limit (EIRP) [dBm]	Margin [dB]		Horizontal		Vertical		Remarks		
	HOR	VER	HOR	VER				HOR	VER		HOR	VER	HOR	VER	Rx Ant.	Turn		Rx Ant.	Turn
															Height	Table		Height	Table
2101.80	57.0	55.2	-51.5	-53.3	3.5	10.9	0.0	-44.2	-46.0	-13.0	31.2	33.0	101	172	100	262			
3700.40	51.1	50.1	-55.1	-57.0	4.7	12.4	0.0	-47.5	-49.4	-13.0	34.5	36.4	143	54	153	151			
5550.60	47.9	47.6	-55.2	-58.4	5.9	12.8	0.0	-48.3	-51.5	-13.0	35.3	38.5	100	164	129	221			
7400.80	45.3	48.7	-56.9	-48.8	6.8	11.2	0.0	-52.5	-44.4	-13.0	39.5	31.4	100	164	131	156			

**Tx 1880MHz**

Frequency [MHz]	Rx SA/TR Reading [dBuV]		Tx SG Reading [dBm]		Tx Cable Loss [dB]	Tx Ant. Gain [dBi]	Tx Ant. Atten. Loss [dB]	Result (EIRP) [dBm]		Limit (EIRP) [dBm]	Margin [dB]		Horizontal		Vertical		Remarks		
	HOR	VER	HOR	VER				HOR	VER		HOR	VER	HOR	VER	Rx Ant.	Turn		Rx Ant.	Turn
															Height	Table		Height	Table
2124.00	54.2	51.1	-55.2	-59.2	3.5	10.9	0.0	-47.9	-51.9	-13.0	34.9	38.9	101	144	130	272			
3760.00	52.0	50.9	-53.3	-56.1	4.8	12.4	0.0	-45.7	-48.5	-13.0	32.7	35.5	137	53	150	166			
5640.00	49.8	47.4	-51.9	-59.5	5.9	12.9	0.0	-44.9	-52.5	-13.0	31.9	39.5	107	345	106	225			
7520.00	48.7	49.9	-47.4	-47.4	6.9	11.1	0.0	-43.2	-43.2	-13.0	30.2	30.2	110	6	120	170			

**Tx 1909.8MHz**

Frequency [MHz]	Rx SA/TR Reading [dBuV]		Tx SG Reading [dBm]		Tx Cable Loss [dB]	Tx Ant. Gain [dBi]	Tx Ant. Atten. Loss [dB]	Result (EIRP) [dBm]		Limit (EIRP) [dBm]	Margin [dB]		Horizontal		Vertical		Remarks		
	HOR	VER	HOR	VER				HOR	VER		HOR	VER	HOR	VER	Rx Ant.	Turn		Rx Ant.	Turn
															Height	Table		Height	Table
2146.20	52.0	49.7	-58.5	-61.8	3.6	10.9	0.0	-51.2	-54.5	-13.0	38.2	41.5	100	144	100	341			
3819.60	50.6	50.6	-55.9	-56.1	4.8	12.4	0.0	-48.3	-48.5	-13.0	35.3	35.5	136	41	150	180			
5729.40	50.7	47.8	-49.7	-56.4	6.0	13.0	0.0	-42.7	-49.4	-13.0	29.7	36.4	105	341	102	219			
7639.20	50.1	50.5	-47.4	-47.2	6.9	11.2	0.0	-43.1	-42.9	-13.0	30.1	29.9	109	36	153	156			

Calculation Result = SG Reading - Tx Cable Loss + Tx Antenna Gain - Tx Antenna Attenuator Loss  
Rx-ANTENNA : Biconical Antenna(30M-300MHz), Logperiodic Antenna(300M-1000MHz), Horn Antenna(1G-40GHz)  
Tx-ANTENNA : 120MHz tuned Dipole Antenna(30M-120MHz), Dipole Antenna(120M-1000MHz), Horn Antenna(1G-40GHz)  
Other frequency noises omitted in this report were not seen or had enough margin (more than 20dB).  
Detector : S/A PK(RBW:1MHz/VBW:3MHz)

**Spurious Emission (Radiated)**  
**W-CDMA Band II**

Test place Head Office EMC Lab. No.4 and No.2 Semi Anechoic Chamber  
Report No. 33IE0012-HO  
Date 04/15/2013 04/16/2013 04/18/2013  
Temperature / Humidity 24deg. C / 32% RH 24deg. C / 47% RH 23deg. C / 42% RH  
Engineer Hironobu Ohnishi Hironobu Ohnishi Tomohisa Nakagawa  
(Below 1GHz) (1-10GHz) (Above 10GHz)  
Mode Tx W-CDMA(RMC12.2kbps), All Up Bits

**Tx: 1852.4MHz**

Frequency [MHz]	Rx SA/TR Reading [dBuV]		Tx SG Reading [dBm]		Tx Cable Loss [dB]	Tx Ant. Gain [dBi]	Tx Ant. Atten. Loss [dB]	Result (EIRP) [dBm]		Limit (EIRP) [dBm]	Margin [dB]		Horizontal		Vertical		Remarks				
	HOR	VER	HOR	VER				HOR	VER		HOR	VER	HOR	VER	HOR	VER		Rx Ant.	Turn	Rx Ant.	Turn
																		Height [cm]	Table [deg.]	Height [cm]	Table [deg.]
3704.80	48.0	48.0	-58.2	-59.1	4.8	12.4	0.0	-50.6	-51.5	-13.0	37.6	38.5	131	16	104	172					
5557.20	47.7	48.2	-55.4	-57.8	5.9	12.8	0.0	-48.5	-50.9	-13.0	35.5	37.9	100	33	120	157					
7409.60	47.9	49.3	-54.3	-48.2	6.8	11.2	0.0	-49.9	-43.8	-13.0	36.9	30.8	112	340	162	216					

**Tx: 1880.0MHz**

Frequency [MHz]	Rx SA/TR Reading [dBuV]		Tx SG Reading [dBm]		Tx Cable Loss [dB]	Tx Ant. Gain [dBi]	Tx Ant. Atten. Loss [dB]	Result (EIRP) [dBm]		Limit (EIRP) [dBm]	Margin [dB]		Horizontal		Vertical		Remarks				
	HOR	VER	HOR	VER				HOR	VER		HOR	VER	HOR	VER	HOR	VER		Rx Ant.	Turn	Rx Ant.	Turn
																		Height [cm]	Table [deg.]	Height [cm]	Table [deg.]
3760.00	47.8	47.1	-57.5	-59.9	4.8	12.4	0.0	-49.9	-52.3	-13.0	36.9	39.3	133	38	105	161					
5640.00	46.8	45.2	-54.9	-61.7	5.9	12.9	0.0	-47.9	-54.7	-13.0	34.9	41.7	104	13	119	164					
7520.00	47.5	48.5	-48.6	-48.8	6.9	11.1	0.0	-44.4	-44.6	-13.0	31.4	31.6	119	32	167	192					

**Tx: 1907.6MHz**

Frequency [MHz]	Rx SA/TR Reading [dBuV]		Tx SG Reading [dBm]		Tx Cable Loss [dB]	Tx Ant. Gain [dBi]	Tx Ant. Atten. Loss [dB]	Result (EIRP) [dBm]		Limit (EIRP) [dBm]	Margin [dB]		Horizontal		Vertical		Remarks				
	HOR	VER	HOR	VER				HOR	VER		HOR	VER	HOR	VER	HOR	VER		Rx Ant.	Turn	Rx Ant.	Turn
																		Height [cm]	Table [deg.]	Height [cm]	Table [deg.]
3815.20	48.8	47.1	-57.7	-59.6	4.8	12.4	0.0	-50.1	-52.0	-13.0	37.1	39.0	125	15	100	154					
5722.80	47.0	45.6	-53.4	-58.6	6.0	13.0	0.0	-46.4	-51.6	-13.0	33.4	38.6	102	12	194	164					
7630.40	48.1	49.8	-49.4	-47.9	6.9	11.2	0.0	-45.1	-43.6	-13.0	32.1	30.6	100	37	166	178					

Calculation Result = SG Reading - Tx Cable Loss + Tx Antenna Gain - Tx Antenna Attenuator Loss

Rx-ANTENNA : Biconical Antenna(30M-300MHz), Logperiodic Antenna(300M-1000MHz), Horn Antenna(1G-40GHz)

Tx-ANTENNA : 120MHz tuned Dipole Antenna(30M-120MHz), Dipole Antenna(120M-1000MHz), Horn Antenna(1G-40GHz)

Other frequency noises omitted in this report were not seen or had enough margin (more than 20dB).

Detector : S/A PK(RBW:1MHz/VBW:3MHz)

**UL Japan, Inc.**

**Head Office EMC Lab.**

4383-326 Asama-cho, Ise-shi, Mie-ken 516-0021 JAPAN

Telephone : +81 596 24 8999

Facsimile : +81 596 24 8124

**Frequency Stability (Temperature/Voltage Variation)**

**PCS1900**

**Tx:1880.0MHz**

Test place Head Office EMC Lab. No.6 Measurement Room  
Report No. 33IE0012-HO  
Date 04/17/2013  
Temperature/ Humidity 23deg. C / 58% RH  
Engineer Yutaka Yoshida  
Mode Tx GSM(GMSK), 1slot, PCL=0

Temp. [deg.C]	Volt. [V]	Frequency Reading [MHz]	Frequency Error [Hz]	Frequency Error [ppm]	Remark
-30.0	4.00	1880.00002992	19.30	0.01027	-
-20.0	4.00	1880.00002203	11.41	0.00607	-
-10.0	4.00	1880.00002804	17.42	0.00927	-
0.0	4.00	1880.00003892	28.30	0.01505	-
10.0	4.00	1880.00001974	9.12	0.00485	-
20.0	4.00	1880.00001062	0.00	0.00000	Reference
30.0	4.00	1880.00003472	24.10	0.01282	-
40.0	4.00	1880.00001236	1.74	0.00093	-
50.0	4.00	1880.00001482	4.20	0.00223	-

Temp. [deg.C]	Volt. [V]	Frequency Reading [MHz]	Frequency Error [Hz]	Frequency Error [ppm]	Remark
20.0	3.50	1880.00002434	13.72	0.00730	-
20.0	4.00	1880.00001062	0.00	0.00000	Reference
20.0	4.30	1880.00003303	22.41	0.01192	-

**UL Japan, Inc.**

**Head Office EMC Lab.**

4383-326 Asama-cho, Ise-shi, Mie-ken 516-0021 JAPAN

Telephone : +81 596 24 8999

Facsimile : +81 596 24 8124

**Frequency Stability (Temperature/Voltage Variation)**

**W-CDMA Band II**

**Tx: 1880.0MHz**

Test place Head Office EMC Lab. No.6 Measurement Room  
Report No. 33IE0012-HO  
Date 04/17/2013  
Temperature/ Humidity 23deg. C / 58% RH  
Engineer Yutaka Yoshida  
Mode Tx W-CDMA(RMC12.2kbps), All Up Bits

Temp. [deg.C]	Volt. [V]	Frequency Reading [MHz]	Frequency Error [Hz]	Frequency Error [ppm]	Remark
-30.0	4.00	1880.0000643	23.68	0.01260	-
-20.0	4.00	1880.0003389	3.78	0.00201	-
-10.0	4.00	1879.9998948	40.63	0.02161	-
0.0	4.00	1880.0003338	-3.27	0.00174	-
10.0	4.00	1879.9998816	41.95	0.02231	-
20.0	4.00	1880.0003011	0.00	0.00000	Reference
30.0	4.00	1880.0003030	0.19	0.00010	-
40.0	4.00	1879.9998814	41.97	0.02232	-
50.0	4.00	1880.0002980	0.31	0.00016	-

Temp. [deg.C]	Volt. [V]	Frequency Reading [MHz]	Frequency Error [Hz]	Frequency Error [ppm]	Remark
20.0	3.50	1880.0003175	1.64	0.00087	-
20.0	4.00	1880.0003011	0.00	0.00000	Reference
20.0	4.30	1880.0003596	5.85	0.00311	-

**UL Japan, Inc.**

**Head Office EMC Lab.**

4383-326 Asama-cho, Ise-shi, Mie-ken 516-0021 JAPAN

Telephone : +81 596 24 8999

Facsimile : +81 596 24 8124

## APPENDIX 2: Test instruments

### EMI test equipment

Control No.	Instrument	Manufacturer	Model No	Serial No	Test Item	Calibration Date * Interval(month)
MAEC-04	Semi Anechoic Chamber(NSA)	TDK	Semi Anechoic Chamber 3m	DA-10005	RE	2013/02/28 * 12
MOS-15	Thermo-Hygrometer	Custom	CTH-180	-	RE	2013/02/26 * 12
MJM-09	Measure	KDS	E19-55	-	RE	-
COTS-MEMI	EMI measurement program	TSJ	TEPTO-DV	-	RE	-
MSA-03	Spectrum Analyzer	Agilent	E4448A	MY44020357	RE	2012/11/20 * 12
MBA-05	Biconical Antenna	Schwarzbeck	BBA9106	1302	RE	2012/11/18 * 12
MLA-08	Logperiodic Antenna	Schwarzbeck	UKLP9140-A	N/A	RE	2012/11/18 * 12
MCC-50	Coaxial Cable	UL Japan	-	-	RE	2012/06/01 * 12
MAT-68	Attenuator	Anritsu	MP721B	6200961025	RE	2012/11/21 * 12
MPA-14	Pre Amplifier	SONOMA INSTRUMENT	310	260833	RE	2013/03/12 * 12
MURC-03	Radio Communication Analyzer	Anritsu	MT8815B	6200711471	RE	2012/12/19 * 12
MAEC-02	Semi Anechoic Chamber(NSA)	TDK	Semi Anechoic Chamber 3m	DA-06902	RE	2012/06/29 * 12
MOS-22	Thermo-Hygrometer	Custom	CTH-201	0003	RE	2013/02/26 * 12
MJM-14	Measure	KOMELON	KMC-36	-	RE	-
MSA-04	Spectrum Analyzer	Agilent	E4448A	US44300523	RE	2013/04/03 * 12
MHA-06	Horn Antenna 1-18GHz	Schwarzbeck	BBHA9120D	254	RE	2013/02/15 * 12
MPA-10	Pre Amplifier	Agilent	8449B	3008A02142	RE	2013/01/10 * 12
MCC-132	Microwave Cable	HUBER+SUHNER	SUCOFLEX104	336161/4(1m)/340639(5m)	RE	2012/09/05 * 12
MRF-02	Band Rejection Filter(1850-1910MHz)	TOKYO KEIKI	1850-1910MHz	-	RE	2012/06/05 * 12
MHA-21	Horn Antenna 1-18GHz	Schwarzbeck	BBHA9120D	9120D-557	RE	2012/08/17 * 12
MCC-130	Microwave Cable (1-33GHz)	HUBER+SUHNER	SF103/11PC3.5-31/11PC3.5-31/8.0m	54308/3	RE	2013/01/29 * 12
KSG-05	Signal Generator	Rohde & Schwarz	SMR40	100137	RE	2012/07/23 * 12
MHF-17	High Pass Filter 3.5-18.0GHz	TOKIMEC	TF323DCA	7001	RE	2012/09/12 * 12
MURC-02	Wireless Communication Test Set	Agilent	E5515C	GB47050683	AT	2012/12/19 * 12
MCC-137	Microwave cable	HUBER+SUHNER	SUCOFLEX 102	37954/2	AT	2012/10/19 * 12
MCH-04	Temperature and Humidity Chamber	Tabai Spec	PL-2KP	14015723	AT	2012/08/01 * 12
MOS-14	Thermo-Hygrometer	Custom	CTH-201	-	AT	2013/02/26 * 12
MMM-11	Digital HiTESTER	Hioki	3805	060100600	AT	2012/05/18 * 12
MDPS-20	REGULATED DC POWER SUPPLY	TEXIO	PW16-5ADP	171116437	AT	Pre Check
MPD-01	PowerDivider DC to 26.5GHz	Agilent	11636B	52258	AT	2013/03/28 * 12
MAT-25	Attenuator(10dB) (above1GHz)	Agilent	8493C	71642	AT	2012/06/27 * 12
MURC-05	Wideband Radio Communication Tester	Rohde & Schwarz	CMW500	127576	AT	2012/10/04 * 12
MSA-10	Spectrum Analyzer	Agilent	E4448A	MY46180655	AT	2013/02/22 * 12

### UL Japan, Inc.

#### Head Office EMC Lab.

4383-326 Asama-cho, Ise-shi, Mie-ken 516-0021 JAPAN

Telephone : +81 596 24 8999

Facsimile : +81 596 24 8124

The expiration date of the calibration is the end of the expired month.  
All equipment is calibrated with valid calibrations. Each measurement data is traceable to the national or international standards.

As for some calibrations performed after the tested dates, those test equipment have been controlled by means of an unbroken chains of calibrations.

**Test Item:**

**RE: Radiated Emission**

**AT: Antenna terminal conducted test**

---

**UL Japan, Inc.**

**Head Office EMC Lab.**

4383-326 Asama-cho, Ise-shi, Mie-ken 516-0021 JAPAN

Telephone : +81 596 24 8999

Facsimile : +81 596 24 8124