



Nemko Korea Co., Ltd.

155 & 159, Osan-Ro, Mohyeon-Myeon, Cheoin-Gu, Yongin-Si, Gyeonggi-Do 449-852 KOREA, REPUBLIC OF

TEL:+82 31 330-1700 FAX:+82 31 322 2332

FCC EVALUATION REPORT FOR CERTIFICATION

Applicant :

Samsung Electronics Co., Ltd.
129, Samsung-ro, Yeongtong-gu,
Suwon-si, Gyeonggi-do, Korea.
(Post code : 443-742)
Attn. : Minhyung. Cho

Dates of Issue : June 16, 2015
Test Report No. : NK-15-R-056
Test Site : Nemko Korea Co., Ltd.

FCC ID

A3LCYLHDE01A

Brand Name

SAMSUNG

Contact Person

Samsung Electronics Co., Ltd.
129, Samsung-ro, Yeongtong-gu,
Suwon-si, Gyeonggi-do, Korea, 443-742.
Minhyung Cho
Telephone No. : +82-31-277-2688

Applied Standard: FCC 47 CFR Part 15.249
Classification: Digital modulation Transmitter
EUT Type: ZigBee/Z-wave Dongle

The device bearing the brand name and model specified above has been shown to comply with the applicable technical standards as indicated in the measurement report and was tested in accordance with the measurement procedures specified in ANSI C63.10-2009. The client should not use it to claim product endorsement by TAF or any government agencies. The test results in the report only apply to the tested sample.

I attest to the accuracy of data and all measurements reported herein were performed by me or were made under my supervision and are correct to the best of my knowledge and belief. I assume full responsibility for the completeness of these measurements and vouch for the qualifications of all persons taking them.

 Jun 16, 2015

Tested By : Wonho Son
Engineer

 Jun 16, 2015

Reviewed By : Deokha Ryu
Technical Manager

TABLE OF CONTENTS

1. Scope	4
2. Introduction (Site Description)	5
2.1 Test facility	5
2.2 Accreditation and listing	6
3. Test Conditions & EUT Information	7
3.1 Operation During Test	7
3.1.1 Table of test power setting	7
3.1.2 Table of test channels	7
3.1.3 Table of test modes	8
3.1.4 Antenna information	8
3.2 Support Equipment	9
3.3 Setup Drawing	9
3.4 EUT Information	10
4. Summary of Test Results	11
5. Recommendation / Conclusion	12
6. Antenna Requirements	12
7. Description of Test	13
7.1 Conducted Emissions	13
7.2 Radiated Emissions	14
7.3 Field Strength of Fundamental	15
7.4 Field Strength of Harmonics	15
7.5 Emissions Radiated Outside of the Fundamental Frequency Band	16
7.6 Duty Cycle	17
8. Test Data	18
8.1 Conducted Emissions	18
8.2 Radiated Emissions	22

8.3 Field Strength of Fundamental	28
8.4 Field Strength of Harmonics	31
8.5 Emissions Radiated Outside of the Fundamental Frequency Band	35
9. Test Equipment	39
10. Accuracy of Measurement	40
Appendix A: Labelling Requirement	42
Appendix B: Photographs of Test Set-up	43
Appendix C: EUT Photographs	46

1. SCOPE

Measurement and determination of electromagnetic emissions (EME) of radio frequency devices including intentional and/or unintentional radiators for compliance with the technical rules and regulations of the Federal Communications Commission under FCC Part 15.

Responsible Party :	Samsung Electronics Co., Ltd.
Contact Person :	Minhyung Cho
Manufacturer :	Samsung Electronics Co., Ltd. 129, Samsung-ro, Yeongtong-gu, Suwon-si, Gyeonggi-do, Korea 443-742

- FCC ID : A3LCYLHDE01A
- Model: CY-LHDE01A
- Brand Name: SAMSUNG
- EUT Type: ZigBee/Z-wave Dongle
- Classification: Digital modulation Transmitter
- Applied Standard: FCC 47 CFR Part 15 subpart C Sections 15.205, 15.207, 15.209 and 15.249

- Test Procedure(s): ANSI C63.10-2009

- Dates of Test: June 04, 2015 ~ June 09, 2015
- Place of Tests: Nemko Korea Co., Ltd.

2. INTRODUCTION

2.1 Test facility

The measurement procedure described in American National Standard for Testing Unlicensed Wireless Devices (ANSI C63.10-2009) was used in determining radiated and conducted emissions emanating from **Samsung Electronics Co., Ltd. FCC ID : A3LCYLHDE01A**

These measurement tests were conducted at **Nemko Korea Co., Ltd. EMC Laboratory**.

The site address 155 & 159, Osan-Ro, Mohyeon-Myeon, Cheoin-Gu, Yongin-Si, Gyeonggi-Do 449-852 KOREA, REPUBLIC OF.

The area of Nemko Korea Corporation Ltd. EMC Test Site is located in a mountain area at 80 km (48 miles) southeast and Incheon International Airport (Incheon Airport), 30 km (18miles) south-southeast from central Seoul.

It is located in the valley surrounded by mountains in all directions where ambient radio signal conditions are quiet and a favorable area to measure the radio frequency interference on open field test site for the computing and ISM devices manufactures.







The detailed description of the measurement facility was found to be in compliance with the requirements of §2.948 according to ANSI C63.4 2009.



Nemko Korea Co., Ltd.
EMC Lab.
155 & 159, Osan-Ro, Mohyeon-Myeon,
Cheoin-Gu, Yongin-Si, Gyeonggi-Do
449-852 KOREA, REPUBLIC OF
Tel)+82-31-330-1700
Fax)+82-31-322-2332

Fig. 1. The map above shows the Seoul in Korea vicinity area.
The map also shows Nemko Korea Corporation Ltd. EMC Lab. and Incheon Airport.

2.2 Accreditation and listing

Accreditation type		Accreditation number
	CAB Accreditation for DOC	Designation No. KR0026
	KOLAS Accredited Lab. (Korea Laboratory Accreditation Scheme)	Registration No. 155
	Canada IC Registered site	Site No. 2040E
	VCCI registration site(RE/CE/Telecom CE)	Member No. 2118
	EMC CBTL	-
	KCC(RRL)Designated Lab.	Registration No. KR0026

3. TEST CONDITIONS & EUT INFORMATION

3.1 Operation During Test

The EUT is the transceiver which is the module supporting the Z wave mode. (1Tx / 1Rx)
 During the test, the EUT was connected to laptop PC and then a test program was executed to operate duty cycle of EUT continuously and constantly (> 98%)
 The EUT was tested at the lowest channel, middle channel and the highest channel with the maximum output power in accordance with the manufacturer’s specifications. The worst data were recorded in the report.

3.1.1 Table of test power setting

Channel	Frequency (MHz)	Data Rate	Power Setting
1	908.40	40 kbps	10
2	908.42	9.6 kbps	10
3	916.00	100 kbps	27

3.1.2 Table of test channels

Test Channel (CH)	Frequency (MHz)	Modulation Type
1	908.40	2FSK
2	908.42	2FSK
3	916.00	2GFSK

3.1.3 Table of test modes

Test Items	Frequency (MHz)	Data rate (Mbps)	Test Channel (CH)
Conducted Emissions	908.40	40 kbps	1
	908.42	9.6 kbps	2
	916.00	100 kbps	3
Radiated Emissions	908.40	40 kbps	1
	908.42	9.6 kbps	2
	916.00	100 kbps	3
Field Strength of Fundamental	908.40	40 kbps	1
	908.42	9.6 kbps	2
	916.00	100 kbps	3
Field Strength of Harmonics	908.40	40 kbps	1
	908.42	9.6 kbps	2
	916.00	100 kbps	3
Emissions Radiated Outside of the Fundamental Frequency Band	908.40	40 kbps	1
	908.42	9.6 kbps	2
	916.00	100 kbps	3

3.1.4 Antenna information:

Frequency band	Mode	Antenna TX mode	Support MIMO
900 MHz	Z-wave	<input checked="" type="checkbox"/> 1TX, <input type="checkbox"/> 2TX	<input type="checkbox"/> Yes, <input checked="" type="checkbox"/> No
2.4 GHz	Zigbee	<input checked="" type="checkbox"/> 1TX, <input type="checkbox"/> 2TX	<input type="checkbox"/> Yes, <input checked="" type="checkbox"/> No

3.2 Support Equipment

EUT	Samsung Electronics Co., Ltd.	S/N: N/A
Laptop Computer	Samsung Electronics Co., Ltd. Model : NT-R520	FCC DOC S/N : ZK6V93FS8000012Y
AC/DC Adapter	Chicony Power Technology (Suzhou) Co., Ltd. Model : A10-090P1A 1.5 m unshielded power cable	FCC DOC S/N : CNBA4400215ADON81BT01V8

3.3 Setup Drawing

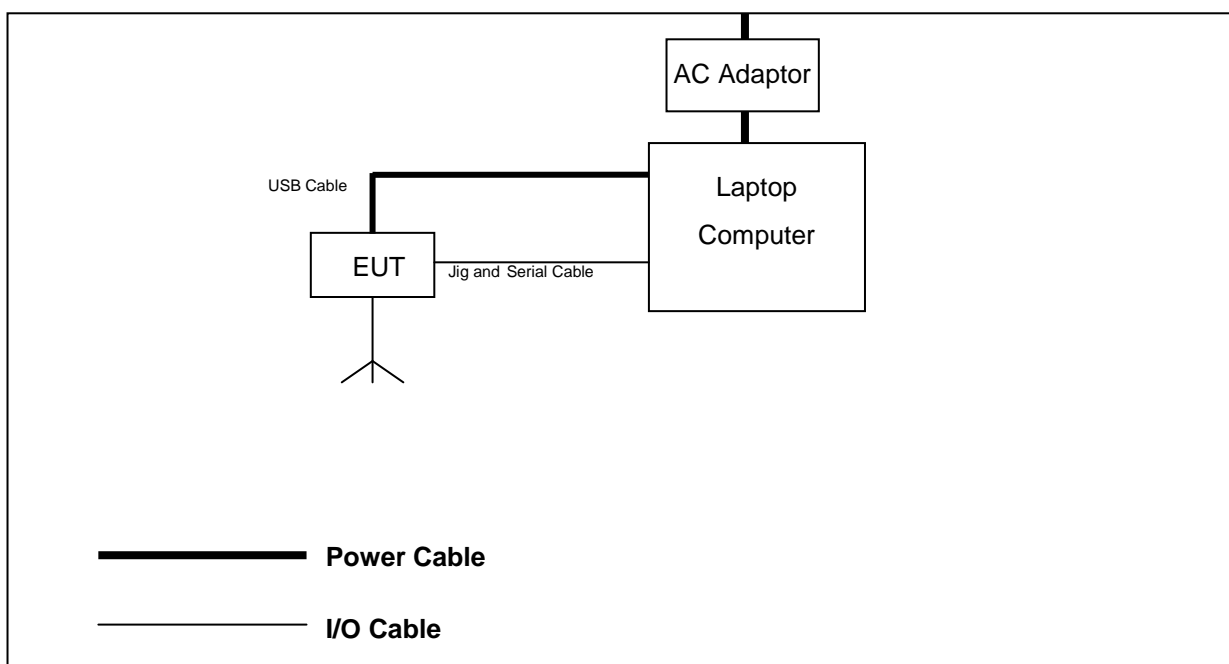

Note:

Serial cable and Jig were removed after controlling the EUT to transmit the wanted signal

3.4 EUT Information

The EUT is the **Samsung ZigBee/Z-wave Dongle FCC ID: A3LCYLHDE01A.**

Specifications:

Category	ZigBee/Z-wave Dongle
Model Name	CY-LHDE01A
Brand Name	SAMSUNG
Frequency of Operation	908.42 MHz, 908.4 MHz, 916 MHz
Number of Channels	3
Antenna Gain (peak)	Zigbee Ant : 4.0 dBi Z-wave Ant : 3.9 dBi
Antenna Setup	1TX / 1RX
Modulations	2FSK (9.6 kbps) for 908.42 MHz 2FSK (40 kbps) for 908.40 MHz 2GFSK (100 kbps) for 916.00 MHz
Temperature Range	-20 °C ~ +50 °C
Voltage	5.0 Vdc
Dimensions (W x H x D)	83 mm x 35 mm X 8 mm
Weight	About 47 g
H/W Status	01
S/W Status	01
Remarks	-

4. SUMMARY OF TEST RESULTS

The EUT has been tested according to the following specification:

Name of Test	FCC Paragraph No.	Result	Remark
Conducted Emission	15.207	Complies	
Radiated Emission	15.209	Complies	
Field Strength of Fundamental	15.249 (a)	Complies	
Field Strength of Harmonics	15.249 (a)	Complies	
Emissions Radiated Outside of the Fundamental Frequency Band	15.249 (d)	Complies	

5. RECOMMENDATION/CONCLUSION

The data collected shows that the **Samsung ZigBee/Z-wave Dongle FCC ID : A3LCYLHDE01A** is in compliance with Part 15 Subpart C 15.249 of the FCC Rules.

6. ANTENNA REQUIREMENTS

§15.203 of the FCC Rules part 15 Subpart C

: An intentional radiator shall be designed to ensure that no antenna other than that furnished by the responsible party shall be used with the device. The use of a permanently attached antenna or of an antenna that uses a unique coupling to the intentional radiator shall be considered sufficient to comply with the provisions of this section.

The antenna of the **Samsung ZigBee/Z-wave Dongle FCC ID : A3LCYLHDE01A** is **permanently attached** and there are no provisions for connection to an external antenna. It complies with the requirement of §15.203.

7. DESCRIPTION OF TESTS

7.1 Conducted Emissions

The Line conducted emission test facility is located inside a 4 x 7 x 2.5 meter shielded enclosure. It is manufactured by EM engineering. The shielding effectiveness of the shielded room is in accordance with MIL-STD-285 or NSA 65-6. A 1 m x 1.5 m wooden table 0.8 m height is placed 0.4 m away from the vertical wall and 1.5 m away from the side of wall of the shielded room Rohde & Schwarz (ESH3-Z5) and (ESH2-Z5) of the 50 ohm/50 μ H Line Impedance Stabilization Network (LISN) are bonded to the shielded room. The EUT is powered from the Rohde & Schwarz LISN (ESH3-Z5) and the support equipment is powered from the Rohde & Schwarz LISN (ESH2-Z5). Power to the LISNs are filtered by high-current high insertion loss Power line filters. The purpose of filter is to attenuate ambient signal interference and this filter is also bonded to shielded enclosure. All electrical cables are shielded by tinned copper zipper tubing with inner diameter of 1 / 2 ". If DC power device, power will be derived from the source power supply it normally will be powered from and this supply lines will be connected to the LISNs, All interconnecting cables more than 1 meter were shortened by non-inductive bundling (serpentine fashion) to a 1 meter length. Sufficient time for EUT, support equipment, and test equipment was allowed in order for them to warm up to their normal operating condition. The RF output of the LISN was connected to the spectrum analyzer to determine the frequency producing the maximum EME from the EUT. The spectrum was scanned from 150 kHz to 30 MHz with 200 msec sweep time. The frequency producing the maximum level was re-examined using the EMI test receiver. (Rohde & Schwarz ESCS30). The detector functions were set to CISPR quasi-peak mode & average mode. The bandwidth of receiver was set to 9 kHz. The EUT, support equipment, and interconnecting cables were arranged and manipulated to maximize each EME emission. Each emission was maximized by; switching power lines; varying the mode of operation or resolution; clock or data exchange speed; scrolling H pattern to the EUT and of support equipment, and powering the monitor from the floor mounted outlet box and computer aux AC outlet, if applicable; whichever determined the worst case emission. Each EME reported was calibrated using the R&S signal generator.

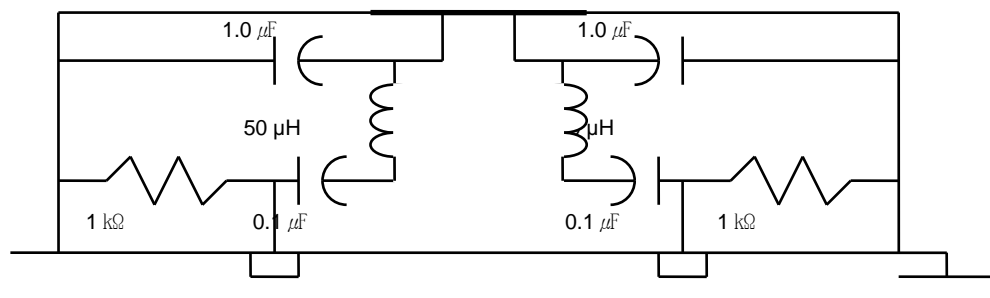

Fig. 2. LISN Schematic Diagram

7.2 Radiated Emissions

The measurement was performed at the test site that is specified in accordance with ANCI C63.10-2009.

The spurious emission was scanned from 9 kHz to 30 MHz using Loop Antenna(Rohde&Schwarz, HFH2-Z2) and 30 to 1000 MHz using Trilog broadband test antenna(Schwarzbeck, VULB 9163). Above 1 GHz, Horn antenna (Schwarzbeck BBHA 9120D: up to 18 GHz, Q-par Angus QSH20S20 : 18 to 26.5 GHz, QSH22K20: up to 40 GHz) was used.

For emissions testing at below 1GHz, The test equipment was placed on turntable with 0.8 m above ground. For emission measurements above 1 GHz, The test equipment was placed on turntable with 1.5 m* above ground. Sufficient time for the EUT, support equipment, and test equipment was allowed in order for them to warm up to their normal operating condition. The EUT, cable, wire arrangement and mode of operation that has the highest amplitude relative to the limit was selected. Then, the turn table was rotated from 0° to 360° and an antenna mast was moved from 1 m to 4 m height to maximize the suspected highest amplitude signal. The final maximized level was recorded.

At frequencies below 1000 MHz, measurements performed using the CISPR quasi-peak detection. At frequencies above 1000 MHz, measurements performed using the peak and average measurement procedures described in Ansi 63.10 – 2009. Peak emission levels were measured by setting the analyzer RBW = 1 MHz, VBW = 3 MHz, Detector = Peak, Trace mode = max hold. Average emission levels were measured by setting the analyzer RBW = 1 MHz, VBW** = 1 kHz, Detector = Peak, Trace mode = max hold, when the EUT was configured to transmit with duty cycle ≥ 98 percent.

Frequency (MHz)	Field strength (microvolts/meter)	Measurement distance (meters)
0.009–0.490	2400/F(kHz)	300
0.490–1.705	24000/F(kHz)	30
1.705–30.0	30	30
30–88	100	3
88–216	150	3
216–960	200	3
Above 960	500	3

Radiated Emissions Limits per 47 CFR 15.209(a)

Note :

1. *Instead of 0.8m EUT height above 1GHz, 1.5m was used as allowed by FCC December 2014 TCB Conference call.
2. **VBW was reduced to 100 times less than the RBW, but no less than 10Hz as allowed by ANSI 63.10-2009, clause 4.2.3.2.3 e)

7.3 Field Strength of Fundamental

Test Procedure

The Transmit Radiated Field Strength was measured at a 3-meter test distance. The EMI Receiver was used to obtain the final test data.

Fundamental frequency	Field strength of fundamental (millivolts/meter)
902-928 MHz	50
2400-2483.5 MHz	50
5725-5875 MHz	50
24.0-24.25 GHz	250

Limits per 47 CFR 15.249(a)

7.4 Field Strength of Harmonics

Test Procedure

The Transmit Radiated Field Strength was measured at a 3-meter test distance. The EMI Receiver was used to obtain the final test data.

Fundamental frequency	Field strength of harmonics (microvolts/meter)
902-928 MHz	500
2400-2483.5 MHz	500
5725-5875 MHz	500
24.0-24.25 GHz	2500

Limits per 47 CFR 15.249(a)

7.5 Emissions Radiated Outside of the Fundamental Frequency Band

Test Procedure

The Band Edge measurement was measured using the EMI Receiver at a 3-meter test distance to obtain the final test data. The lower and upper channels were tuned during the low and high bandedge test.

Emissions radiated outside of the specified frequency bands, except for harmonics, shall be attenuated by at least 50 dB below the level of the fundamental or to the general radiated emission limits in §15.209, whichever is the lesser attenuation.

7.6 Duty Cycle

Test Setup

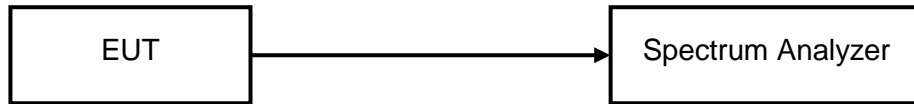

Test Procedure

EUTs duty cycle are measured at middle channel with a spectrum analyzer connected to the antenna terminal while the EUTs operating at its maximum power control level. The spectrum analyzer setting is as follows.

Center frequency = Center frequency of the transmission

Span = zero

RBW = 20 MHz

VBW = 20 MHz

Detector = peak

Sweep time = 5 ms

Trace mode = view

The marker function on the spectrum analyzer is used to determine the duty cycle.

Following the result of the duty cycle measurement according to the above test procedure

Frequency (MHz)	Data Rate (kbps)	Duty Cycle (%)
908.40	40	100
908.42	9.6	100
916.00	100	100

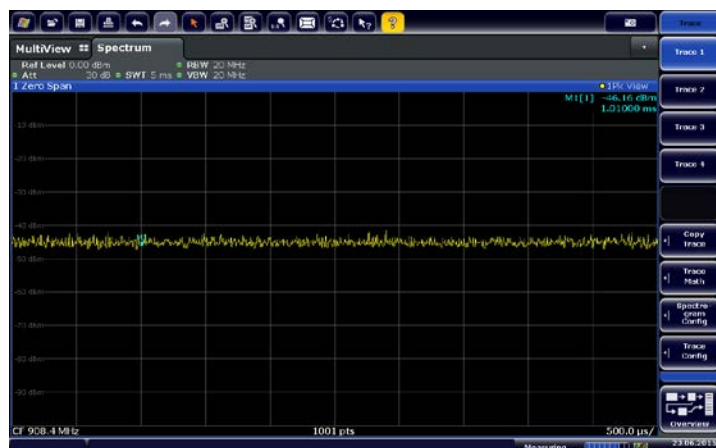

8. TEST DATA

8.1 Conducted Emissions

FCC §15.207

908.40 MHz

Frequency (MHz)	Level(dBµV)		*)Factor (dB)	**) Line	Limit(dBµV)		Margin(dB)	
	Q-Peak	Average			Q-Peak	Average	Q-Peak	Average
0.15	45.8	27.8	10.3	L	66.0	56.0	20.2	28.2
0.17	42.0	14.5	10.3	N	65.0	55.0	23.0	40.5
0.19	39.3	24.2	10.3	L	64.0	54.0	24.7	29.8
0.23	37.5	21.8	10.3	N	62.4	52.4	24.9	30.6
0.26	37.0	19.5	10.3	N	61.4	51.4	24.4	31.9
0.42	32.7	28.3	10.4	L	57.4	47.4	24.7	19.1

Line Conducted Emissions Tabulated Data

908.42 MHz

Frequency (MHz)	Level(dBµV)		*)Factor (dB)	**) Line	Limit(dBµV)		Margin(dB)	
	Q-Peak	Average			Q-Peak	Average	Q-Peak	Average
0.15	40.4	27.4	10.3	N	66.0	56.0	25.6	28.6
0.17	37.8	15.9	10.3	N	65.0	55.0	27.2	39.1
0.19	36.3	22.3	1.3	N	64.0	54.0	27.7	31.7
0.23	35.8	23.3	10.3	L	62.4	52.4	26.6	29.1
0.26	35.2	23.6	10.3	L	61.4	51.4	26.2	27.8
15.30	34.0	27.7	11.3	N	60.0	50.0	26.0	22.3

Line Conducted Emissions Tabulated Data

916.00 MHz

Frequency (MHz)	Level(dBµV)		*)Factor (dB)	**) Line	Limit(dBµV)		Margin(dB)	
	Q-Peak	Average			Q-Peak	Average	Q-Peak	Average
0.15	45.7	27.7	10.3	N	66.0	56.0	20.3	28.3
0.17	39.5	16.6	10.3	L	65.0	55.0	25.5	38.4
0.19	39.1	22.9	10.3	L	64.0	54.0	24.9	31.1
0.22	37.4	23.7	10.3	L	62.8	52.8	25.4	29.1
0.26	37.0	23.5	10.3	L	61.4	51.4	24.4	27.9
0.42	32.8	28.2	10.4	L	57.4	47.4	24.6	19.2

Notes:

1. Measurements using CISPR quasi-peak mode & average mode.
2. All modes of operation were investigated and the worst -case emission are reported.
See attached Plots.
3. *) Factor = LISN + Cable Loss
4. **) LINE : L = Line , N = Neutral
5. The limit is on the FCC Part section 15.207(a).

PLOTS OF EMISSIONS

Worst Channel : 908.40 MHz

- Conducted Emission at the Mains port (Line)**

NEMKO KOREA (NK-15-R-056)

04 Jun 2015 12:27

Conducted Emissions

EUT: ZigBee/Z-wave Dongle
 Manuf: Samsung Electronics Co., Ltd.
 Op Cond: a.c. 120 V / 60 Hz, Z wave : 908.40 MHz (40 kbps)
 Operator: Wonho. Son
 Test Spec: FCC Part 15
 Comment: MODEL : CY-LHDE01A
 LINE : LINE-PE
 Result File: r56_40l.dat : New Measurement

Scan Settings (1 Range)

Frequencies			Receiver Settings						
Start	Stop	Step	IF BW	Detector	M-Time	Atten	Preamp	OpRge	
150kHz	30MHz	3.9063kHz	9kHz	PK+AV	20msec	20 dB	OFF	60dB	

Transducer	No.	Start	Stop	Name
	1	150kHz	30MHz	ESH3_Z5_Line

Final Measurement: Detectors: X QP / + AV
 Meas Time: 1sec
 Subranges: 8
 Acc Margin: 60 dB

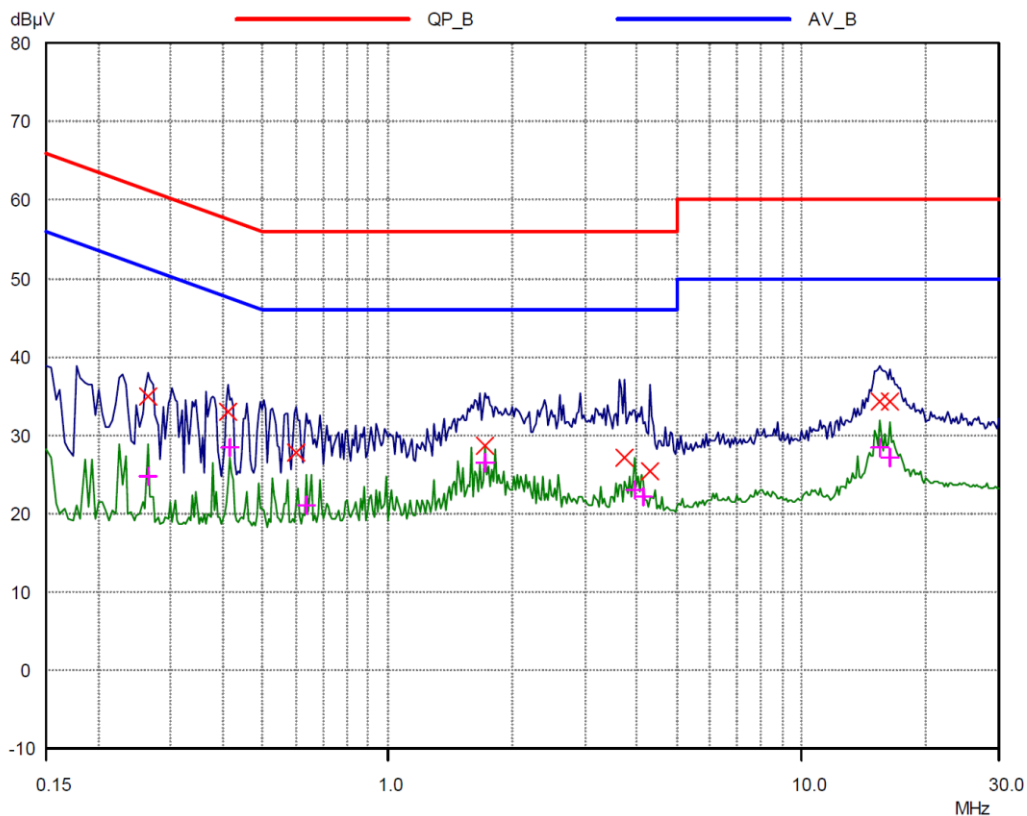

PLOTS OF EMISSIONS

Worst Channel : 908.40 MHz

- **Conducted Emission at the Mains port (Neutral)**

NEMKO KOREA (NK-15-R-056)

04 Jun 2015 11:59

Conducted Emissions

EUT: ZigBee/Z-wave Dongle
 Manuf: Samsung Electronics Co., Ltd.
 Op Cond: a.c. 120 V / 60 Hz, Z wave : 908.40 MHz (40 kbps)
 Operator: Wonho. Son
 Test Spec: FCC Part 15
 Comment: MODEL : CY-LHDE01A
 LINE : NEUTRAL-PE
 Result File: r56_40n.dat : New Measurement

Scan Settings (1 Range)

Frequencies		Receiver Settings						
Start	Stop	Step	IF BW	Detector	M-Time	Atten	Preamp	OpRge
150kHz	30MHz	3.9063kHz	9kHz	PK+AV	20msec	20 dB	OFF	60dB

Transducer	No.	Start	Stop	Name
	1	150kHz	30MHz	ESH3_Z5_Neutral

Final Measurement: Detectors: X QP / + AV
 Meas Time: 1sec
 Subranges: 8
 Acc Margin: 60 dB

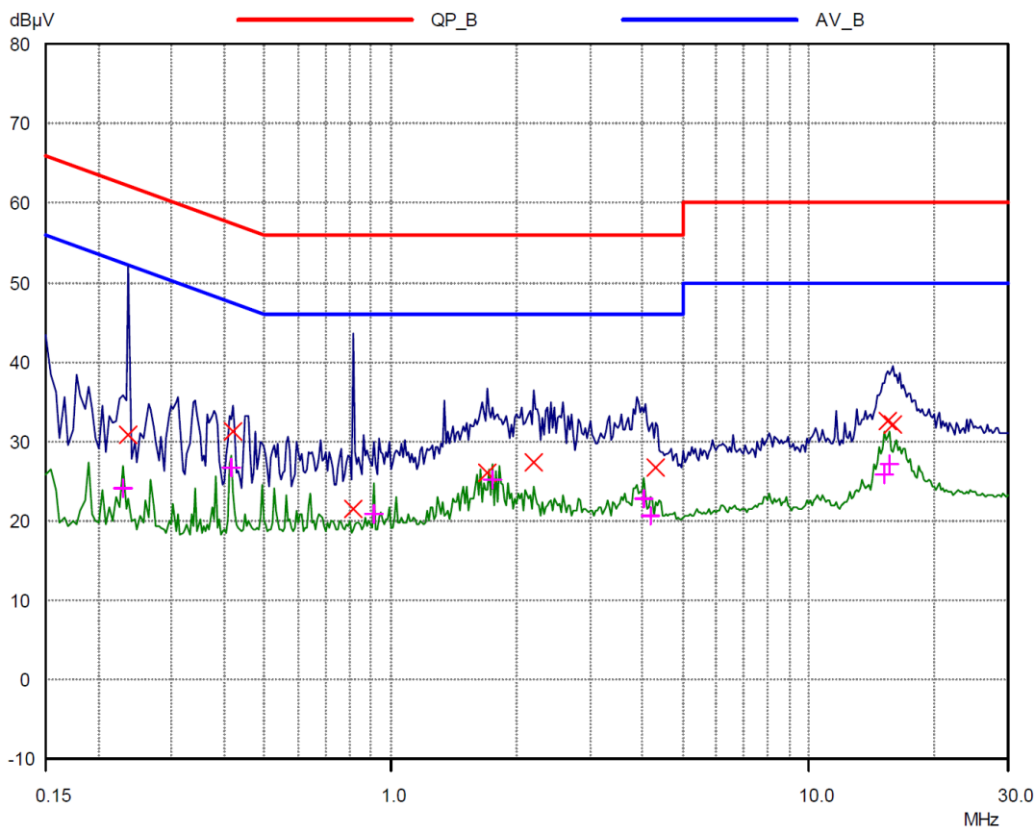

TEST DATA

8.2 Radiated Emissions

FCC §15.209

908.40 MHz (Below 1 GHz)

Frequency (MHz)	Reading (dBµV/m)	Pol* (H/V)	Antenna Heights (cm)	Turntable Angles (°)	AF+CL+Amp (dB)**	Result (dBµV/m)	Limit (dBµV/m)	Margin (dB)
279.24	43.90	H	117	259	-21.2	22.7	46.0	23.3
455.35	46.60	H	300	284	-16.0	30.6	46.0	15.4
468.00	41.60	H	100	146	-15.7	25.9	46.0	20.1
48.03	47.70	H	100	234	-15.3	32.4	46.0	13.6
833.40	42.70	V	286	149	-9.7	33.0	46.0	13.0
875.02	38.90	H	200	31	-9.1	29.8	46.0	16.2

908.42 MHz (Below 1 GHz)

Frequency (MHz)	Reading (dBµV/m)	Pol* (H/V)	Antenna Heights (cm)	Turntable Angles (°)	AF+CL+Amp (dB)**	Result (dBµV/m)	Limit (dBµV/m)	Margin (dB)
455.05	49.30	H	186	165	-15.9	33.4	46.0	12.6
480.37	35.80	H	197	167	-15.3	20.5	46.0	25.5
538.72	32.70	H	170	341	-13.9	18.8	46.0	27.2
814.00	43.30	H	100	71	-10.3	33.0	46.0	13.0
833.30	38.90	H	100	52	-9.9	29.0	46.0	17.0
852.95	40.80	H	116	211	-9.6	31.2	46.0	14.8

916.00 MHz (Below 1 GHz)

Frequency (MHz)	Reading (dBµV/m)	Pol* (H/V)	Antenna Heights (cm)	Turntable Angles (°)	AF+CL+Amp (dB)**	Result (dBµV/m)	Limit (dBµV/m)	Margin (dB)
433.33	42.10	H	297	278	-16.4	25.7	46.0	20.3
466.69	41.40	H	309	320	-15.7	25.7	46.0	20.3
480.66	36.90	H	100	267	-15.3	21.6	46.0	24.4
483.33	37.80	H	310	320	-15.3	22.5	46.0	23.5
833.31	43.60	V	100	199	-9.7	33.9	46.0	12.1
838.88	37.80	V	100	139	-9.6	28.2	46.0	17.8

Radiated Measurements at 3meters

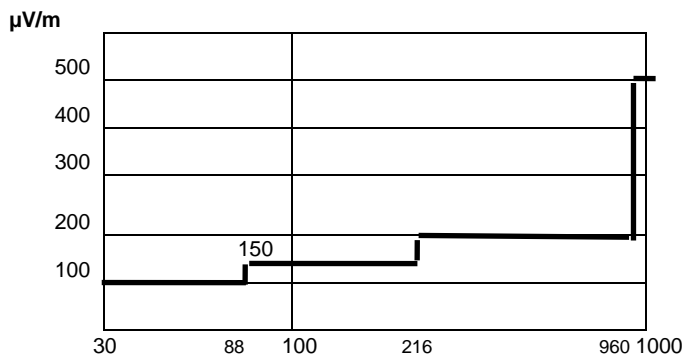

Fig. 3. Limits at 3 meters

Notes:

1. All modes were measured and the worst-case emission was reported.
 2. The radiated limits are shown on Figure 3.
- Above 1 GHz the limit is 500 μV/m.

3. *Pol. H = Horizontal, V = Vertical
4. **AF + CL + Amp. = Antenna Factor + Cable Loss + Amplifier.
5. Measurements using CISPR quasi-peak mode.
6. There were no radiated emissions other than harmonics found below 30 MHz.
7. The radiated emissions testing were made by rotating through three orthogonal axes.
The worst date was recorded.

PLOTS OF EMISSIONS

916.00 MHz (below 1GHz)

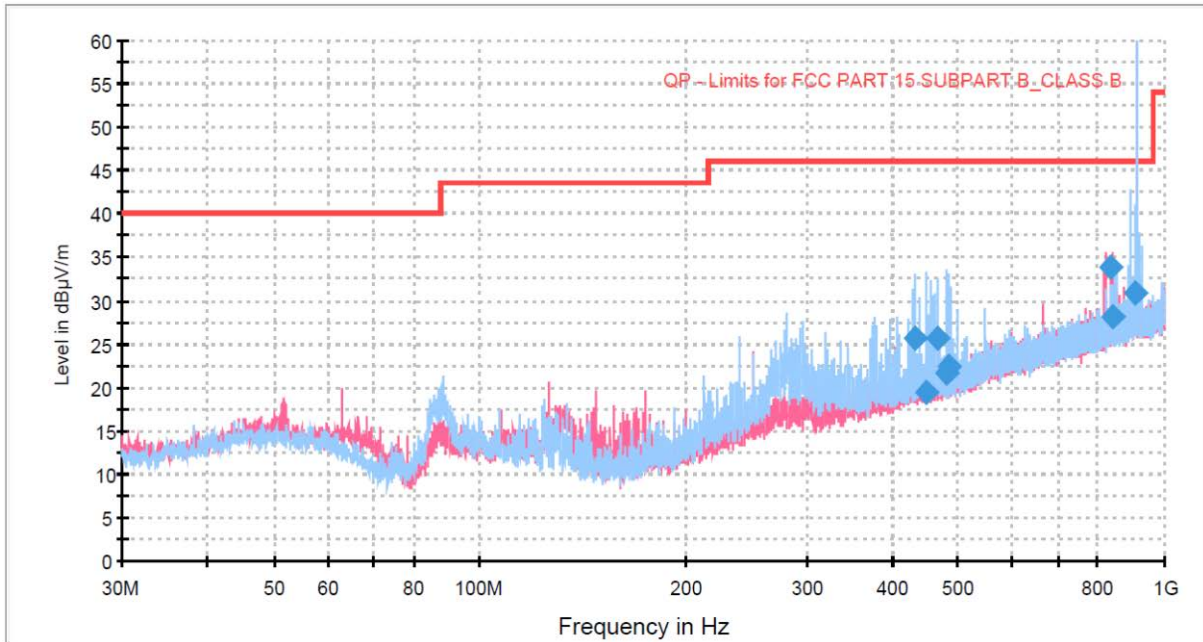

TEST DATA

FCC §15.209

908.40 (Above 1 GHz)

Frequency (MHz)	Pol* (H/V)	Detector** (PK/AV)	AF+CL+Amp (dB)***	Result (dBµV/m)	Limit (dBµV/m)	Margin (dB)	Comment
1675.25	V	PK	-2.3	46.5	74.0	48.8	
1675.25	V	AV	-2.3	35.3	54.0	37.6	
2246.50	V	PK	-0.4	46.6	74.0	47.0	
2246.50	V	AV	-0.4	35.2	54.0	35.6	

908.42 (Above 1 GHz)

Frequency (MHz)	Pol* (H/V)	Detector** (PK/AV)	AF+CL+Amp (dB)***	Result (dBµV/m)	Limit (dBµV/m)	Margin (dB)	Comment
1702.00	V	PK	-2.3	46.9	74.0	49.2	
1702.00	V	AV	-2.3	34.3	54.0	36.6	
2242.50	V	PK	-0.4	46.3	74.0	46.7	
2242.50	V	AV	-0.4	34.2	54.0	34.6	

916.00 (Above 1 GHz)

Frequency (MHz)	Pol* (H/V)	Detector** (PK/AV)	AF+CL+Amp (dB)***	Result (dBµV/m)	Limit (dBµV/m)	Margin (dB)	Comment
1542.75	V	PK	-2.8	48.6	74.0	51.4	
1542.75	V	AV	-2.8	34.5	54.0	37.3	
1693.50	V	PK	-2.3	45.7	74.0	48.0	
1693.50	V	AV	-2.3	34.8	54.0	37.1	
2243.25	V	PK	-0.4	46.7	74.0	47.1	
2243.25	V	AV	-0.4	34.4	54.0	34.8	

Radiated Measurements at 3meters

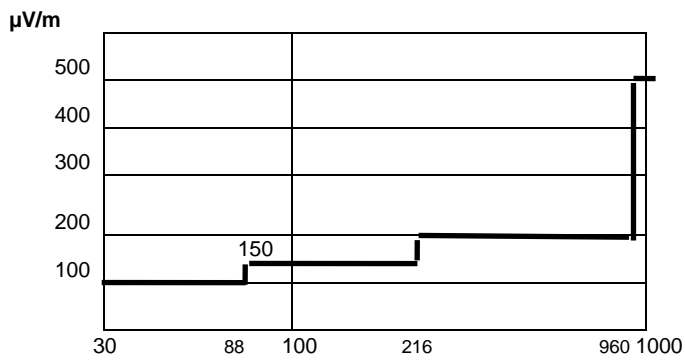

Fig. 3. Limits at 3 meters

Notes:

1. All modes were measured and the worst-case emission was reported.

2 The radiated limits are shown on Figure 3.

Above 1 GHz the limit is 500 μV/m.

MHz

3. *Pol. H = Horizontal, V = Vertical

4. **AF + CL + Amp. = Antenna Factor + Cable Loss + Amplifier.

5. ***Detector. PK = Peak, AV = Average

6. Measurements using peak and average mode.

7. The radiated emissions testing were made by rotating through three orthogonal axes.

The worst date was recorded.

8. The spectrum was measured from 9 kHz to 10th harmonic and the worst-case emissions were reported.

PLOTS OF EMISSIONS

Worst Channel (916 MHz) : Above 1GHz to 10th Harmonic of highest fundamental frequency

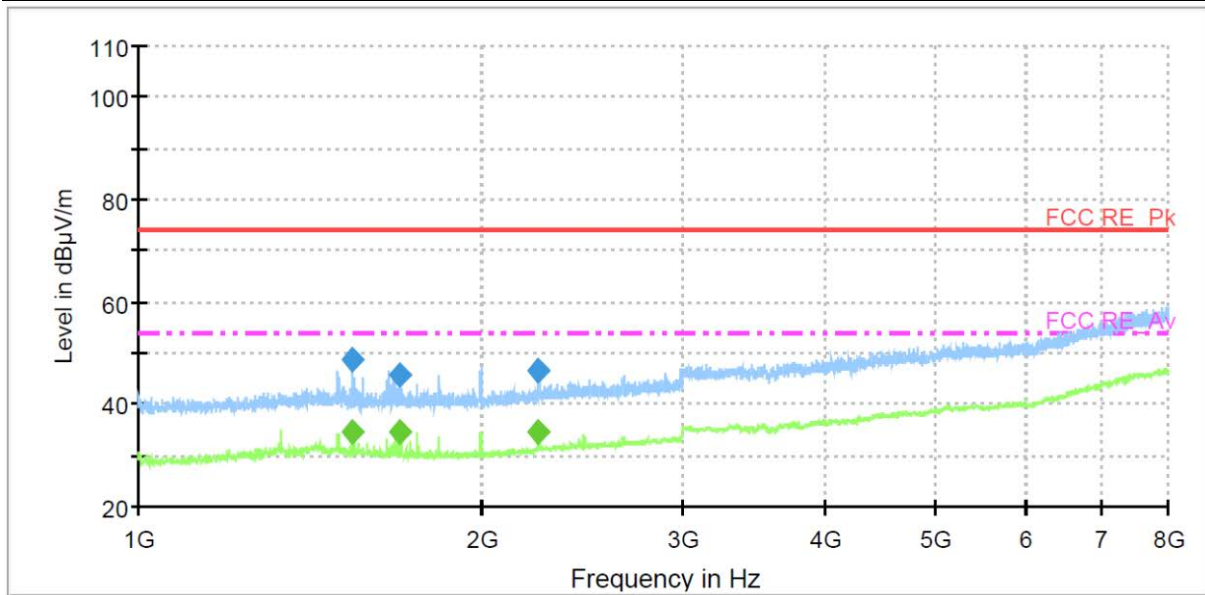

Worst Channel (916 MHz) : Above 1GHz to 10th Harmonic of highest fundamental frequency

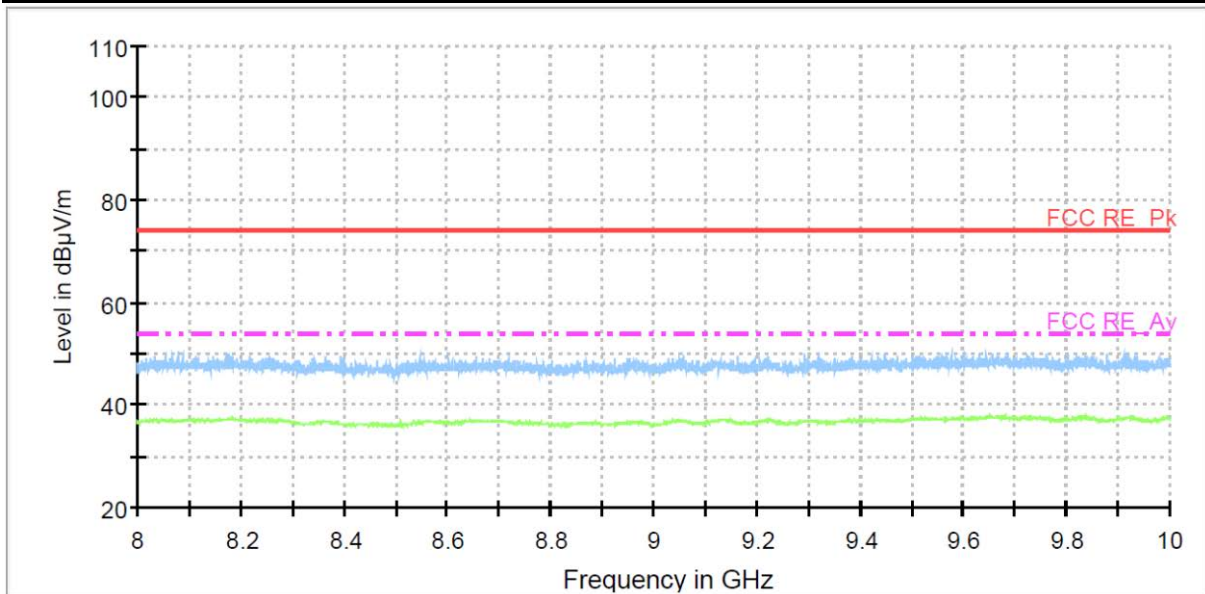

TEST DATA

8.3 Field Strength of Fundamental

FCC §15.249

Test Mode : Set to Lowest channel, Middle channel and Highest channel

Frequency (MHz)	Reading (dBμV/m)	Pol* (H/V)	Antenna Heights (cm)	Turntable Angles (°)	AF+CL+Amp (dB)**	Result (dBμV/m)	Detector (PK/QP)***	Limit (dBμV/m)	Margin (dB)
908.40	100.20	H	100	221	-8.8	91.4	PK	114.0	22.6
908.40	100.10	H	100	221	-8.8	91.3	QP	94.0	2.7
908.42	100.40	H	100	226	-8.8	91.6	PK	114.0	22.4
908.42	100.30	H	100	226	-8.8	91.5	QP	94.0	2.5
916.00	100.50	H	100	214	-8.8	91.7	PK	114.0	22.3
916.00	100.00	H	100	214	-8.8	91.2	QP	94.0	2.8

Notes:

- *Pol. H = Horizontal, V = Vertical
- **AF + CL + Amp. = Antenna Factor + Cable Loss + Amplifier.
- ***Detector. PK = Peak, QP = Quasi Peak
- RBW = 120 kHz, VBW = 300 kHz
- The radiated emissions testing were made by rotating through three orthogonal axes.
The worst date was recorded.

PLOTS OF EMISSIONS

908.40 MHz

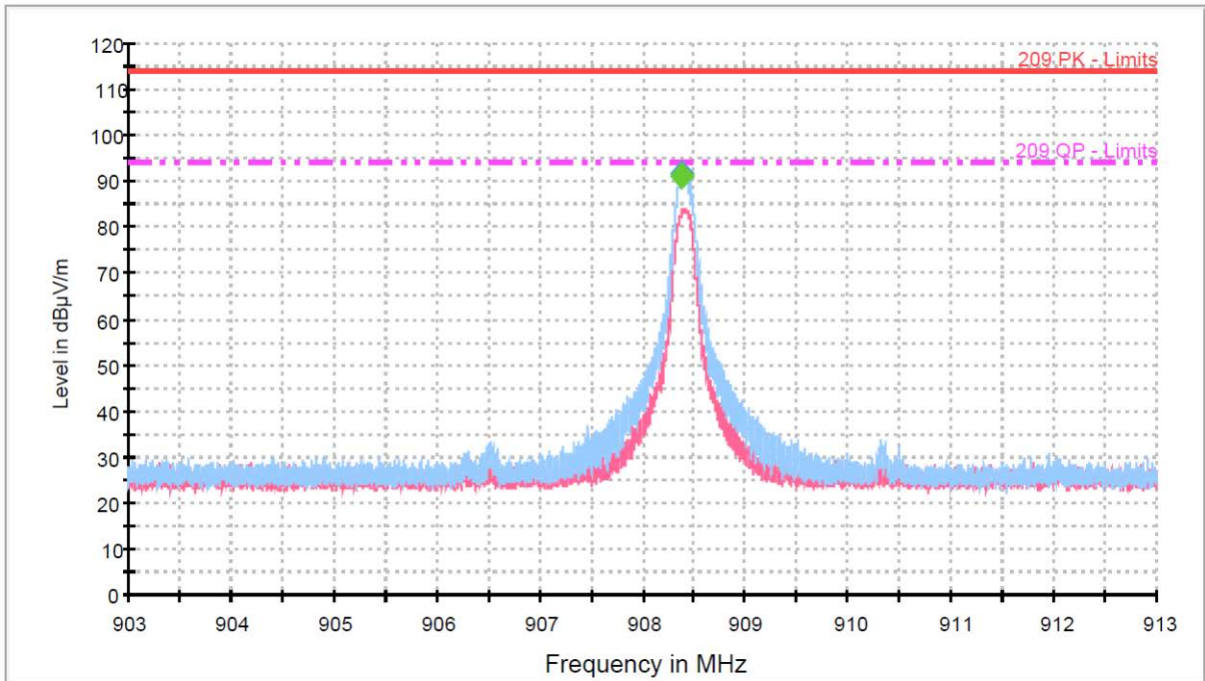

908.42 MHz

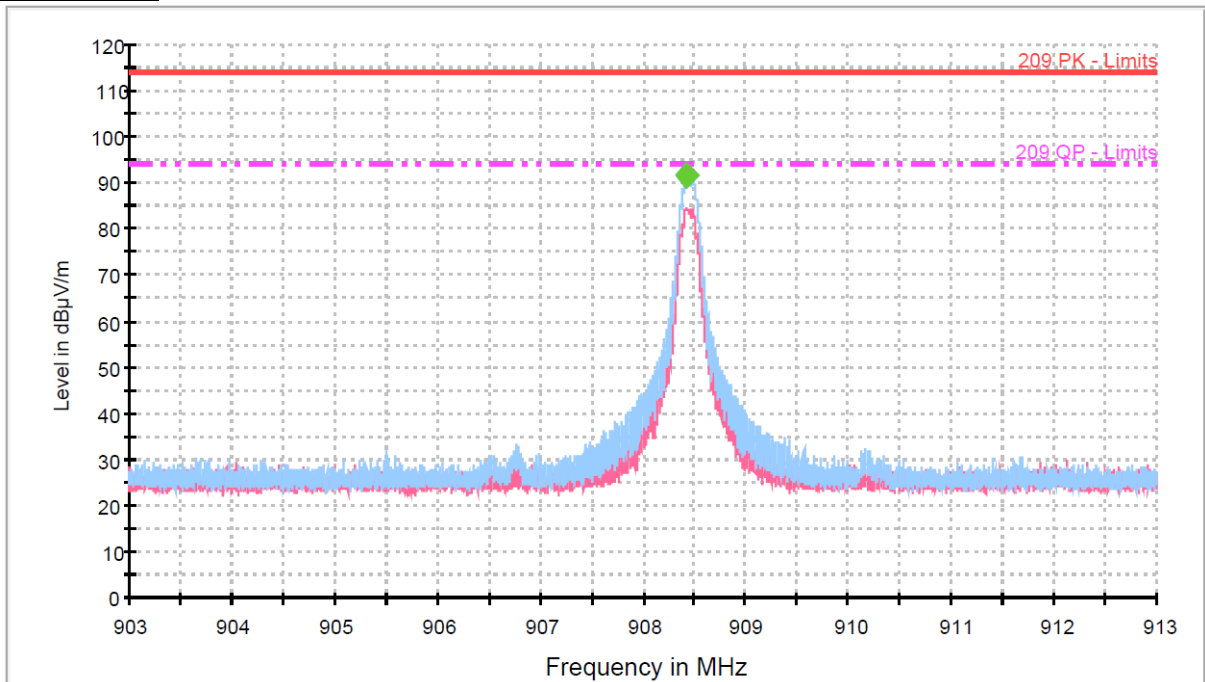

PLOTS OF EMISSIONS

916.00 MHz

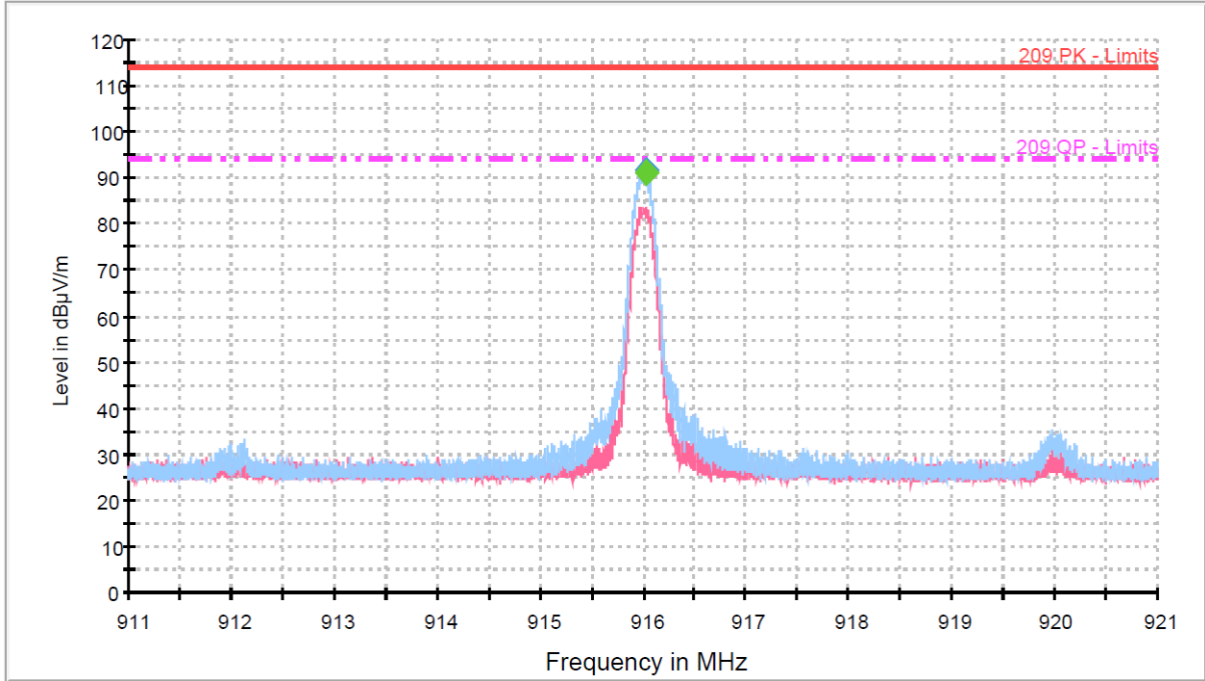

TEST DATA

8.4 Field Strength of Harmonics

FCC §15.249

Test Mode : Set to Lowest channel, Middle channel and Highest channel

908.40 MHz

Frequency (MHz)	Pol* (H/V)	Detector* (PK/AV)**	AF+CL+Amp (dB)***	Result (dBµV/m)	Limit (dBµV/m)	Margin (dB)	Comment
1816.80	H	PK	-2.1	40.6	74.0	42.7	
1816.80	H	AV	-2.1	30.3	54.0	32.4	
2725.20		PK			74.0		No Emissions Found
2725.20		AV			54.0		No Emissions Found
3633.60		PK			74.0		No Emissions Found
3633.60		AV			54.0		No Emissions Found
4542.00		PK			74.0		No Emissions Found
4542.00		AV			54.0		No Emissions Found
5450.40		PK			74.0		No Emissions Found
5450.40		AV			54.0		No Emissions Found
6358.80		PK			74.0		No Emissions Found
6358.80		AV			54.0		No Emissions Found
7267.20		PK			74.0		No Emissions Found
7267.20		AV			54.0		No Emissions Found
8175.60		PK			74.0		No Emissions Found
8175.60		AV			54.0		No Emissions Found
9084.00		PK			74.0		No Emissions Found
9084.00		AV			54.0		No Emissions Found

TEST DATA

908.42 MHz

Frequency (MHz)	Pol* (H/V)	Detector (PK/AV)**	AF+CL+Amp (dB)***	Result (dBµV/m)	Limit (dBµV/m)	Margin (dB)	Comment
1816.84	H	PK	-2.1	39.6	74.0	41.7	
1816.84	H	AV	-2.1	30.3	54.0	32.4	
2725.26		PK			74.0		No Emissions Found
2725.26		AV			54.0		No Emissions Found
3633.68		PK			74.0		No Emissions Found
3633.68		AV			54.0		No Emissions Found
4542.10		PK			74.0		No Emissions Found
4542.10		AV			54.0		No Emissions Found
5450.52		PK			74.0		No Emissions Found
5450.52		AV			54.0		No Emissions Found
6358.94		PK			74.0		No Emissions Found
6358.94		AV			54.0		No Emissions Found
7267.36		PK			74.0		No Emissions Found
7267.36		AV			54.0		No Emissions Found
8175.78		PK			74.0		No Emissions Found
8175.78		AV			54.0		No Emissions Found
9084.20		PK			74.0		No Emissions Found
9084.20		AV			54.0		No Emissions Found

TEST DATA

916.00 MHz

Frequency (MHz)	Pol* (H/V)	Detector (PK/AV)**	AF+CL+Amp (dB)***	Result (dBμV/m)	Limit (dBμV/m)	Margin (dB)	Comment
1832.00	H	PK	-2.0	42.0	74.0	44.0	
1832.00	H	AV	-2.0	32.0	54.0	34.0	
2748.00		PK			74.0		No Emissions Found
2748.00		AV			54.0		No Emissions Found
3664.00		PK			74.0		No Emissions Found
3664.00		AV			54.0		No Emissions Found
4580.00		PK			74.0		No Emissions Found
4580.00		AV			54.0		No Emissions Found
5496.00		PK			74.0		No Emissions Found
5496.00		AV			54.0		No Emissions Found
6412.00		PK			74.0		No Emissions Found
6412.00		AV			54.0		No Emissions Found
7328.00		PK			74.0		No Emissions Found
7328.00		AV			54.0		No Emissions Found
8244.00		PK			74.0		No Emissions Found
8244.00		AV			54.0		No Emissions Found
9084.20		PK			74.0		No Emissions Found
9084.20		AV			54.0		No Emissions Found

Notes:

- *Pol. H = Horizontal, V = Vertical
- **Detector. PK = Peak, QP = Quasi Peak
- ***AF + CL + Amp. = Antenna Factor + Cable Loss + Amplifier.
- The radiated emissions testing were made by rotating through three orthogonal axes.
The worst date was recorded.
- PK : RBW = 1 MHz, VBW = 3 MHz, AV : RBW = 1 MHz, VBW = 1 kHz
- No significant emissions were found beyond the 2nd harmonic for this device.

PLOT OF TEST DATA

Worst channel 916.00 MHz : 1 GHz to 8 GHz

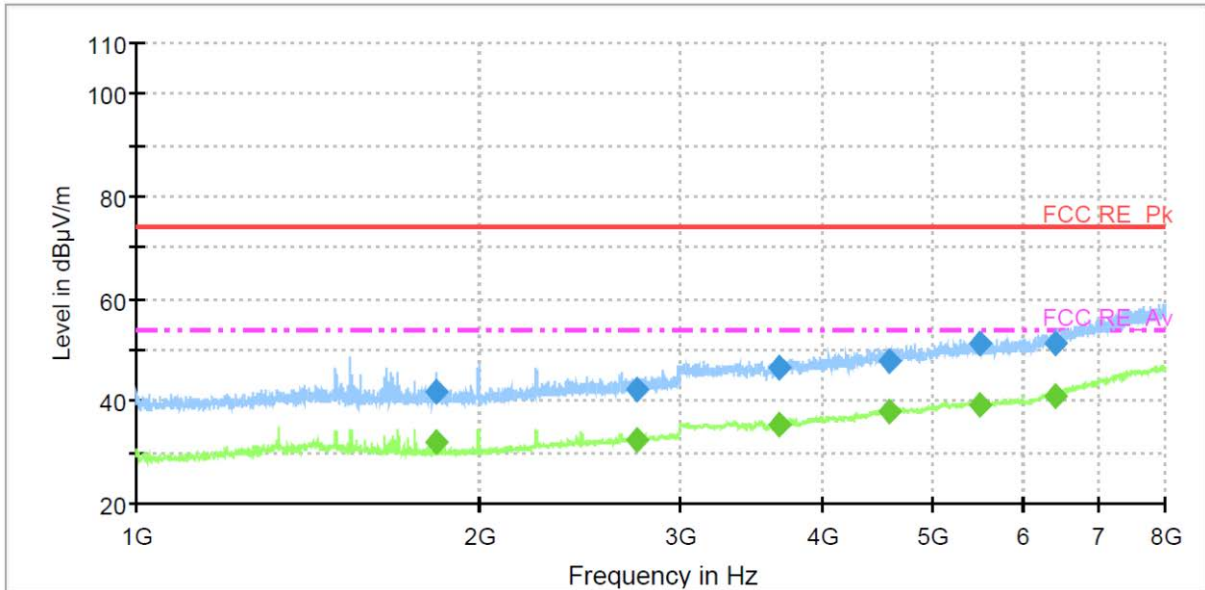

Worst channel 916.00 MHz : 8 GHz to 10 GHz

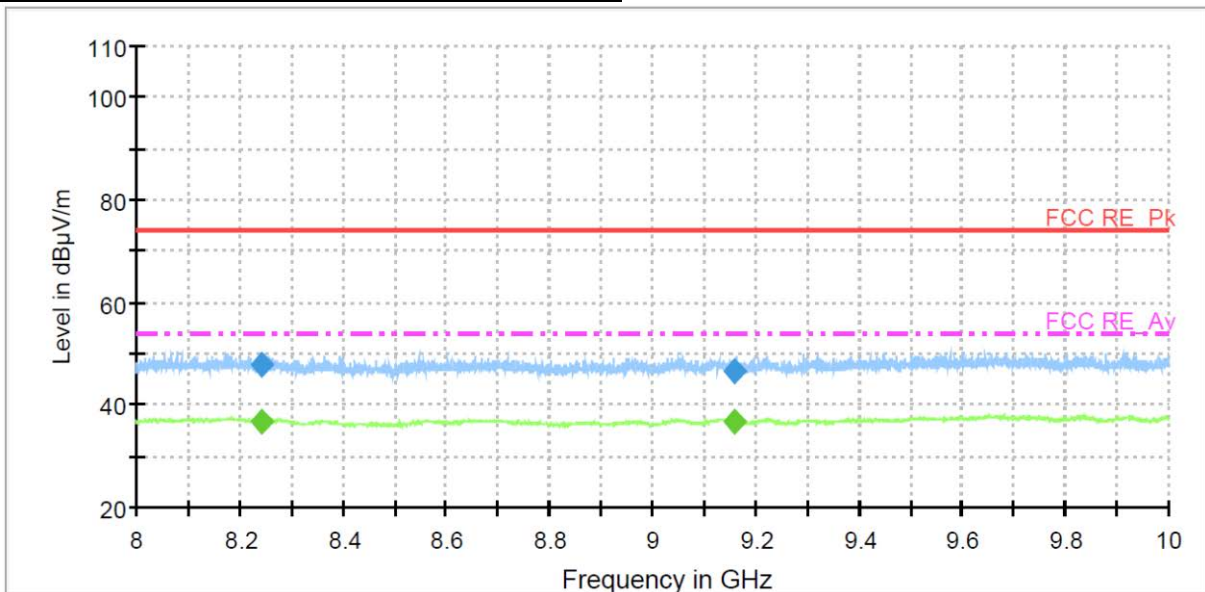

TEST DATA

8.5 Emissions Radiated Outside of the Fundamental Frequency band

FCC §15.249

Test Mode : Set to Lowest channel, Middle channel and Highest channel

908.40 MHz

Frequency (MHz)	Reading (dBµV/m)	Pol** (H/V)	Antenna Heights (cm)	Turntable Angles (°)	AF+CL+Amp (dB)***	Result (dBµV/m)	****Detector PK/QP	Limit (dBµV/m)	Margin (dB)
895.99	43.10	H	100	228	-8.8	34.3	PK	41.4	7.1
902.00	40.80	H	100	40	-8.8	32.0	PK	41.4	9.4
*908.39	100.20	H	100	227	-8.8	91.4	PK	-	-
928.00	41.70	H	100	30	-8.8	32.9	PK	41.4	8.5
928.98	43.00	V	100	85	-8.8	34.2	PK	41.4	7.2

908.42 MHz

Frequency (MHz)	Reading (dBµV/m)	Pol** (H/V)	Antenna Heights (cm)	Turntable Angles (°)	AF+CL+Amp (dB)***	Result (dBµV/m)	****Detector PK/QP	Limit (dBµV/m)	Margin (dB)
896.02	43.00	H	100	227	-8.9	34.1	PK	41.6	7.5
902.00	37.70	V	100	354	-8.8	28.9	PK	41.6	12.7
*908.42	100.40	H	100	228	-8.8	91.6	PK	-	-
928.00	39.00	H	100	337	-8.8	30.2	PK	41.6	11.4
928.46	38.80	H	100	333	-8.8	30.0	PK	41.6	11.6

916.00 MHz

Frequency (MHz)	Reading (dBµV/m)	Pol** (H/V)	Antenna Heights (cm)	Turntable Angles (°)	AF+CL+Amp (dB)***	Result (dBµV/m)	****Detector PK/QP	Limit (dBµV/m)	Margin (dB)
896.02	39.40	H	100	227	-8.8	30.6	PK	41.7	11.1
902.00	42.60	V	100	354	-8.8	33.8	PK	41.7	7.9
*908.42	100.50	H	100	228	-8.8	91.7	PK	-	-
928.00	44.20	H	100	337	-8.8	35.4	PK	41.7	6.3
928.46	37.40	H	100	333	-8.8	28.6	PK	41.7	13.1

TEST DATA

Note(s):

1. " * " : Fundamental frequency
2. **Pol. H = Horizontal V = Vertical
3. ***AF + CL + Amp. = Antenna Factor + Cable Loss + Amplifier.
4. ****Detector PK = Peak
5. The radiated emissions testing were made by rotating EUT through three orthogonal axes and rotating the receive antenna with horizontal, Vertical polarization. The worst data was recorded.
6. Peak emissions were measured using RBW = 100 kHz, VBW = 300 kHz

PLOT OF TEST DATA

908.40 MHz

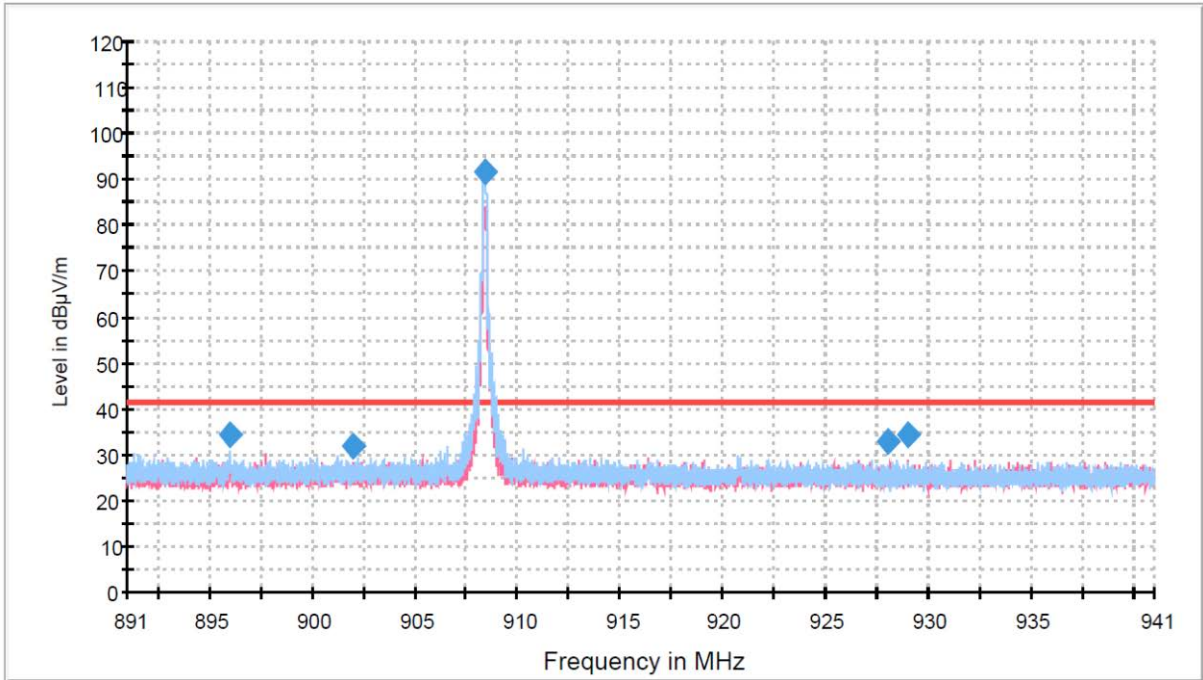

908.40 MHz

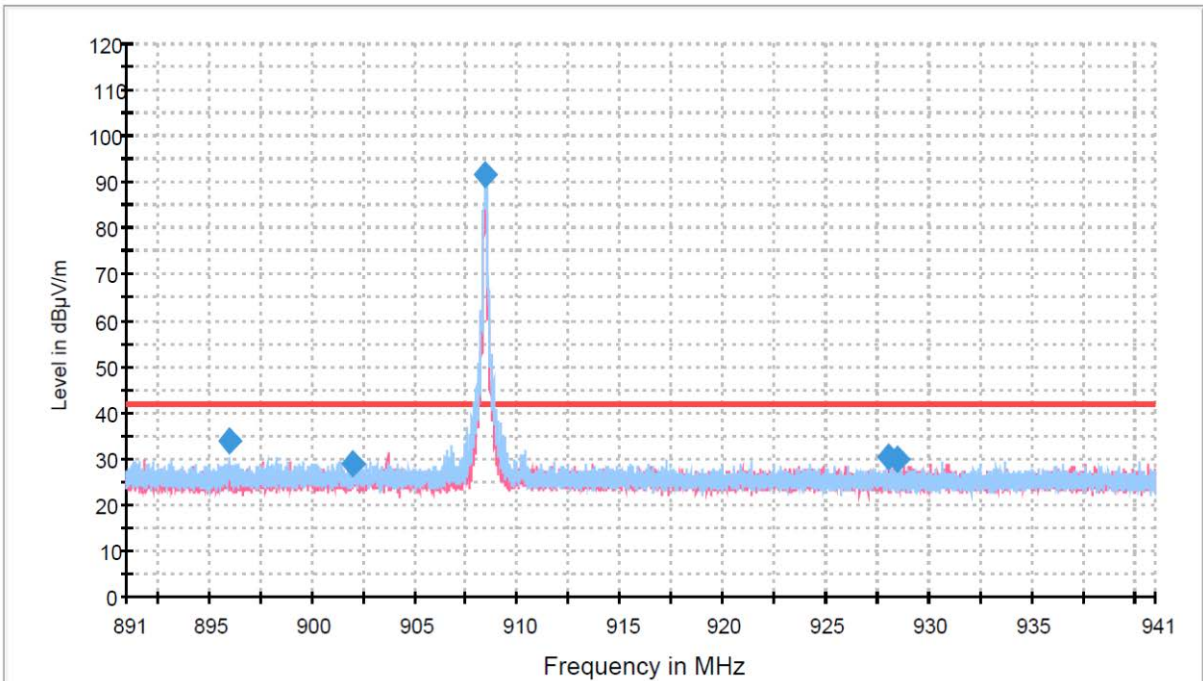

PLOT OF TEST DATA

916.00 MHz

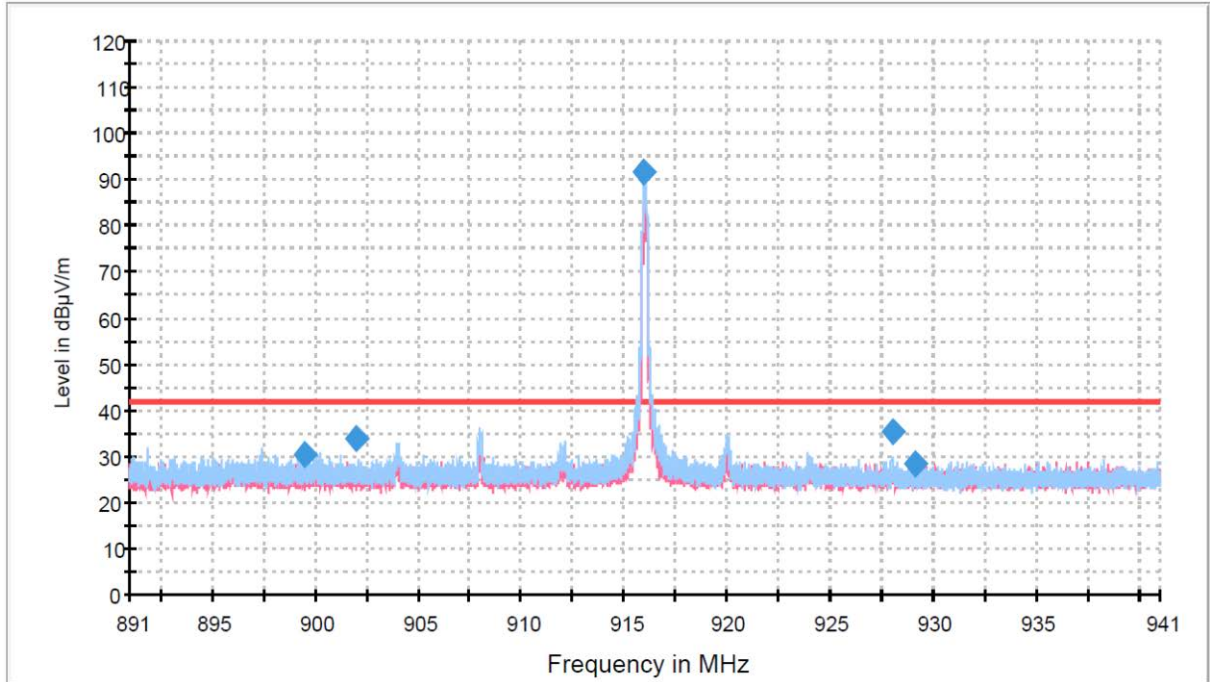

9. TEST EQUIPMENT

No.	Instrument	Manufacturer	Model	Serial No.	Calibration Date	Calibration Interval
1	*Test Receiver	R & S	ESU 40	100202	Apr. 01 2015	1 year
2	*Test Receiver	R & S	ESCS30	100302	Oct. 06 2014	1 year
3	*Attenuator	AGILENT	8491B	57773	Oct. 07 2014	1 year
4	*Attenuator	FAIRVIEW	SA3N5W-06	N/A	Apr. 01 2015	1 year
5	*Attenuator	FAIRVIEW	SA3N5W-10	N/A	Apr. 01 2015	1 year
6	*Attenuator	WEINSCHEL	56-10	58765	Apr. 02 2015	1 year
7	*Amplifier	R & S	SCU 01	10030	Apr. 01 2015	1 year
8	*Amplifier	R & S	SCU18	10065	Apr. 01 2015	1 year
9	Amplifier	R & S	SCU26	10011	Jul. 08 2014	1 year
10	Amplifier	R & S	SCU40	10008	Jul. 08 2014	1 year
11	*Pre Amplifier	HP	8449B	3008A00107	Jan. 09 2015	1 year
12	*Spectrum Analyzer	R & S	FSW43	100732	Apr. 07 2015	1 year
13	Spectrum Analyzer	Agilent	E4440A	MY44022567	Apr. 01 2015	1 year
14	*Spectrum Analyzer	R&S	FSP40	100361	Jul. 16 2014	1 year
15	*DC Power Supply	HP	6574A	US36340190	Jul. 16 2014	1 year
16	*Loop Antenna	R & S	HFH2-Z2	100279	Feb. 13 2014	2 year
17	Wideband Power Sensor	R & S	NRP-Z81	100634	Jul. 17 2014	1 year
18	*Horn Antenna	SCHWARZBECK	BBHA9120D	9120D-474	Sep. 01 2014	2 year
19	Horn Antenna	Q-par Angus	QSH20S20	8179	Apr. 30 2015	2 year
20	Horn Antenna	Q-par Angus	QSH22K20	8180	Apr. 30 2015	2 year
21	*Trilog-Broadband Antenna	SCHWARZBECK	VULB 9163	9163-423	Apr. 17 2014	2 year
22	*LISN	R & S	ESH3-Z5	833874/006	Oct. 06 2014	1 year
23	*Controller	INNCO	CO2000-G	CO2000/562/23890210/L	N/A	N/A
24	*Turn Table	INNCO	DT3000-3T	N/A	N/A	N/A
25	*Antenna Mast	INNCO	MA4000-EP	N/A	N/A	N/A
26	*Open Switch And Control Unit	R & S	OSP-120	100015	N/A	N/A
27	*Anechoic Chamber	Seo-Young EMC	N/A	N/A	N/A	N/A
28	*Position Controller	INNCO	CO2000	12480406/L	N/A	N/A
29	*Turn Table	INNCO	DS1200S	N/A	N/A	N/A
30	*Antenna Mast	INNCO	MA4000	N/A	N/A	N/A
31	*Anechoic Chamber	Seo-Young EMC	N/A	N/A	N/A	N/A
32	Shielded Room	Seo-Young EMC	N/A	N/A	N/A	N/A
33	*Open Switch And Control Unit	R & S	OSP-120	100081	N/A	N/A

*) Test equipment used during the test

10. ACCURACY OF MEASUREMENT

The Measurement Uncertainties stated were calculated in accordance with the requirements of measurement uncertainty contained in CISPR 16-4-2 with the confidence level of 95%

1. Conducted Uncertainty Calculation

Source of Uncertainty	X_i	Uncertainty of X_i		Coverage factor k	$u(X_i)$ (dB)	C_i	$C_i u(X_i)$ (dB)
		Value (dB)	Probability Distribution				
Receiver reading	RI	± 0.1	normal 1	1.000	0.1	1	0.1
Attenuation AMN-Receiver	LC	± 0.08	normal 2	2.000	0.04	1	0.04
AMN Voltage division factor	LAMN	± 0.8	normal 2	2.000	0.4	1	0.4
Sine wave voltage	dVSW	± 2.00	normal 2	2.000	1.00	1	1.00
Pulse amplitude response	dVPA	± 1.50	rectangular	1.732	0.87	1	0.87
Pulse repetition rate response	dVPR	± 1.50	rectangular	1.732	0.87	1	0.87
Noise floor proximity	dVNF	± 0.00	-	-	0.00	1	0.00
AMN Impedance	dZ	± 1.80	triangular	2.449	0.73	1	0.73
Ⓐ Mismatch	M	+ 0.70	U-Shaped	1.414	0.49	1	0.49
Ⓑ Mismatch	M	- 0.80	U-Shaped	1.414	- 0.56	1	- 0.56
Measurement System Repeatability	RS	0.05	normal 1	1.000	0.05	1	0.05
Remark	Ⓐ: AMN-Receiver Mismatch : + Ⓑ: AMN-Receiver Mismatch : -						
Combined Standard Uncertainty	Normal			± 1.88			
Expanded Uncertainty U	Normal ($k = 2$)			± 3.76			

2. Radiation Uncertainty Calculation

Source of Uncertainty	X_i	Uncertainty of X_i		Coverage factor k	$u(X_i)$ (dB)	C_i	$C_i u(X_i)$ (dB)
		Value (dB)	Probability Distribution				
Measurement System Repeatability	RS	0.34	normal 1	1.00	0.34	1	0.34
Receiver reading	Ri	± 0.02	normal 2	2.00	0.01	1	0.01
Sine wave voltage	dVsw	± 0.17	normal 2	2.00	0.09	1	0.09
Pulse amplitude response	dVpa	± 0.92	normal 2	2.00	0.46	1	0.46
Pulse repetition rate response	dVpr	± 0.35	normal 2	2.00	0.18	1	0.18
Noise floor proximity	dVnf	± 0.50	normal 2	2.00	0.25	1	0.25
Antenna Factor Calibration	AF	± 2.00	rectangular	$\sqrt{3}$	1.15	1	1.15
Cable Loss	CL	± 1.00	normal 2	2.00	0.50	1	0.50
Antenna Directivity	AD	± 0.00	rectangular	$\sqrt{3}$	0.00	1	0.00
Antenna Factor Height Dependence	AH	± 2.00	rectangular	$\sqrt{3}$	1.15	1	1.15
Antenna Phase Centre Variation	AP	± 0.20	rectangular	$\sqrt{3}$	0.12	1	0.12
Antenna Factor Frequency Interpolation	Ai	± 0.25	rectangular	$\sqrt{3}$	0.14	1	0.14
Site Imperfections	Si	± 4.00	triangular	$\sqrt{6}$	1.63	1	1.63
Measurement Distance Variation	DV	± 0.60	rectangular	$\sqrt{3}$	0.35	1	0.35
Antenna Balance	Dbal	± 0.90	rectangular	$\sqrt{3}$	0.52	1	0.52
Cross Polarisation	DCross	± 0.00	rectangular	$\sqrt{3}$	0.00	1	0.18
Mismatch	M	+ 0.98 - 1.11	U-Shaped	$\sqrt{2}$	0.74	1	0.74
EUT Volume Diameter	Vd	0.33	normal 1	1.00	0.33	1	0.11
Remark							
Combined Standard Uncertainty	Normal						
Expanded Uncertainty U	Normal ($k = 2$)						