

RF Test Report

Project Number: 4336245**Proposal Number: 6400****Report Number: 4336245EMC01****Revision Level: 1****Client: 4iiii Innovations Inc.****Equipment Under Test: Wireless Pumpjack Sensors****Models: Dynamometer
Inclinometer
Rod Rotation Monitor****FCC ID: ZZNPOD100****IC ID: 9896A-POD100****Applicable Standards: FCC Part 15 Subpart C, § 15.247****RSS-247, Issue 2, February 2017****RSS-GEN, Issue 5, April 2018****ANSI C63.10: 2013****Report issued on: 11 June 2019****Test Result: Compliant**

Tested by:

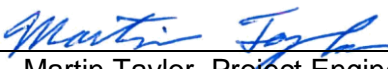

Martin Taylor, Project Engineer

Reviewed by:



David Schramm, Operations Manager

Remarks: This report details the results of the testing carried out on one sample, the results contained in this test report do not relate to other samples of the same product. The manufacturer should ensure that all products in series production are in conformity with the product sample detailed in this report.

This document is issued by the Company under its General Conditions of Service accessible at <http://www.sgs.com/en/Terms-and-Conditions.aspx>. Attention is drawn to the limitation of liability, indemnification and jurisdiction issues defined therein.

Any holder of this document is advised that information contained hereon reflects the Company's findings at the time of its intervention only and within the limits of Client's instructions, if any. The Company's sole responsibility is to its Client and this document does not exonerate parties to a transaction from exercising all their rights and obligations under the transaction documents. Any unauthorized alteration, forgery or falsification of the content or appearance of this document is unlawful and offenders may be prosecuted to the fullest extent of the law.

Table of Contents

1	SUMMARY OF TEST RESULTS.....	4
1.1	MODIFICATIONS REQUIRED FOR COMPLIANCE	4
2	GENERAL INFORMATION.....	5
2.1	CLIENT INFORMATION	5
2.2	TEST LABORATORY	5
2.3	GENERAL INFORMATION OF EUT	5
2.4	OPERATING MODES AND CONDITIONS	5
2.5	EUT CONNECTION BLOCK DIAGRAM – CONDUCTED MEASUREMENTS.....	6
2.6	EUT CONNECTION BLOCK DIAGRAM – RADIATED MEASUREMENTS	6
2.7	SYSTEM CONFIGURATIONS	6
2.8	CABLE LIST	6
3	BANDWIDTH	7
3.1	TEST RESULT.....	7
3.2	TEST METHOD.....	7
3.3	TEST SITE	7
3.4	TEST EQUIPMENT	7
3.5	TEST DATA.....	7
4	OUTPUT POWER	9
4.1	TEST RESULT.....	9
4.2	TEST METHOD.....	9
4.3	TEST SITE	9
4.4	TEST EQUIPMENT	9
4.5	TEST DATA.....	9
5	POWER SPECTRAL DENSITY	11
5.1	TEST RESULT.....	11
5.2	TEST METHOD.....	11
5.3	TEST SITE	11
5.4	TEST EQUIPMENT	11
5.5	TEST DATA.....	11
6	CONDUCTED SPURIOUS EMISSIONS / BAND EDGE.....	13
6.1	TEST RESULT.....	13
6.2	TEST METHOD.....	13
6.3	TEST SITE	13
6.4	TEST EQUIPMENT	13
6.5	TEST DATA – DTS BAND EDGE.....	14
6.6	TEST DATA – CONDUCTED SPURIOUS EMISSIONS	15
7	FIELD STRENGTH OF SPURIOUS RADIATION.....	16
7.1	TEST RESULT.....	16
7.2	TEST METHOD.....	16
7.3	TEST SITE	16
7.4	TEST EQUIPMENT	17
7.5	TEST DATA – PEAK PLOTS.....	18
7.6	TEST DATA – TABULAR DATA.....	36
8	EMISSIONS IN RESTRICTED FREQUENCY BANDS.....	37
8.1	TEST RESULT.....	37
8.2	TEST METHOD.....	37



8.3 TEST SITE 37

8.4 TEST EQUIPMENT 37

8.5 TEST DATA – RESTRICTED BAND EDGE 38

9 REVISION HISTORY 39

APPENDIX A: DUTY-CYCLE CALCULATIONS 40

1 Summary of Test Results

Test Description	Test Specification		Test Result
Bandwidth	15.247(a)(2)	RSS-247 S5.2 (a) RSS-GEN S6.7	Compliant
Transmitter Output Power	15.247(b)(3)	RSS-247 S5.4 (d)	Compliant
Power Spectral Density	15.247(e)	RSS-247 S5.2 (b)	Compliant
Conducted Spurious Emissions / Band Edge	15.247(d)	RSS-247 S5.5	Compliant
Field Strength of Spurious Radiation	15.247(d) 15.205, 15.209	RSS-247 S5.5 RSS-GEN S8.9, S8.10	Compliant
Emissions in Restricted Frequency Bands	15.205, 15.209	RSS-GEN S8.9, S8.10	Compliant
Antenna Requirement	15.203	RSS-GEN S6.8	Compliant ⁽¹⁾
AC Powerline Conducted Emissions	15.207	RSS-GEN S8.8	NA ⁽²⁾

(1) The device uses internal PCB trace antennas.

(2) The device does not connect to the AC Mains.

1.1 Modifications Required for Compliance

None

2 General Information

2.1 Client Information

Name: 4iiii Innovations Inc.
Address: 141 2nd Ave East
City, State, Zip, Country: Cochrane, Alberta, Canada T4C 2B9

2.2 Test Laboratory

Name: SGS North America, Inc.
Address: 620 Old Peachtree Road NW, Suite 100
City, State, Zip, Country: Suwanee, GA 30024, USA

Accrediting Body: A2LA
Type of lab: Testing Laboratory
Certificate Number: 3212.01

2.3 General Information of EUT

Type of Product: Wireless Pumpjack Sensors
Models: Dynamometer
Inclinometer
Rod Rotation Monitor
(all use the same PCB with different sensor stuffing options;
radios are identical in all three models)

Serial Number: Not labeled

FCC ID: ZZNPOD100
IC ID: 9896A-POD100

Frequency Range: 2402 – 2480 MHz
Data Modes: Bluetooth Low Energy
Antenna: Two Internal PCB Trace Antennas (selectable, both 0dBi)

Rated Voltage: 3.6 Vdc
Test Voltage: 3.6 Vdc

Sample Received Date: 15 October 2018
Dates of testing: 04 January to 08 February 2019 (all except Dynamometer RSE)
07-10 June 2019 (RSE on Dynamometer with load cell cable)

2.4 Operating Modes and Conditions

Continuous traffic was generated using test commands issued by means of a smart phone app supplied by the client. Where the duty cycle measured below 99% and an RMS detector was employed, corrections of $10 \cdot \text{LOG}(1/D)$ were applied according to KDB publication 558074 D01 15.247 Meas Guidance v05r02.

2.5 EUT Connection Block Diagram – Conducted Measurements

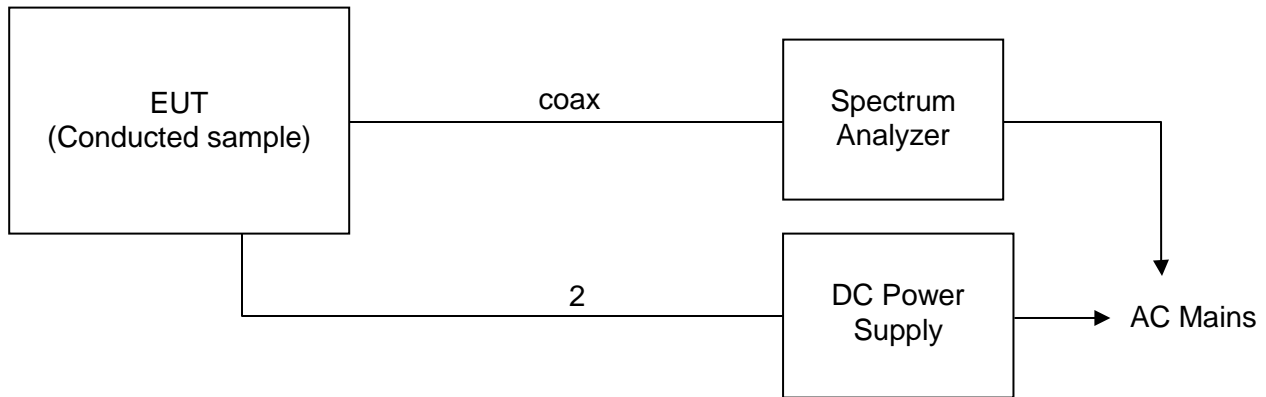

2.6 EUT Connection Block Diagram – Radiated Measurements

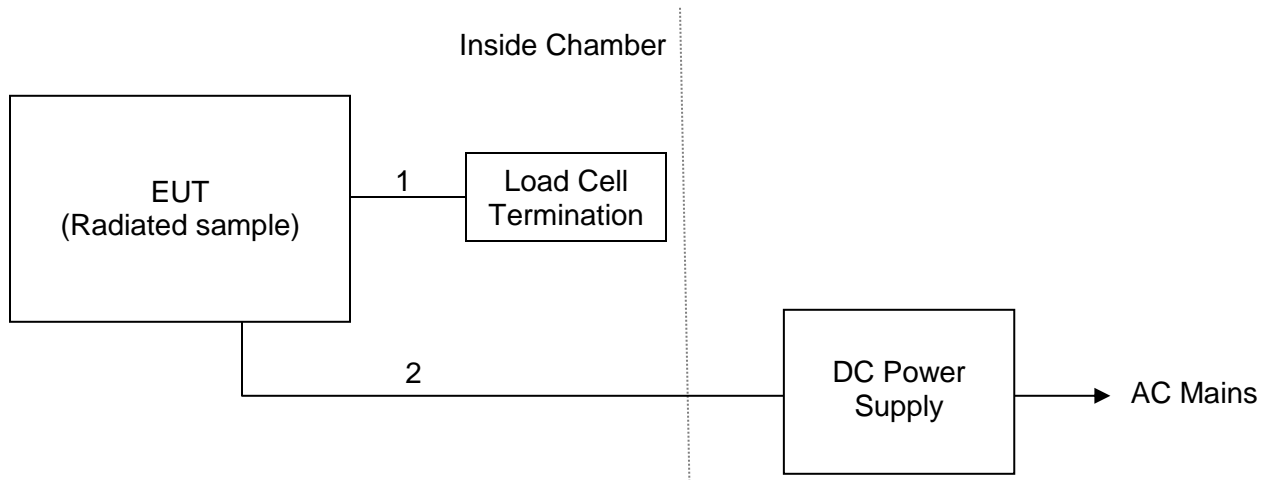

2.7 System Configurations

Manufacturer	Description	Model Number	Serial Number
4iiii Innovations Inc.	Wireless Sensor (EUT)	Dynamometer Inclinometer Rod Rotation Monitor	Not labeled
Rigol	DC Power Supply	DP711	DP7A182700833

2.8 Cable List

Cable reference	Port Name	Start	End	Cable Length (m)	Ferrite installed?	Shielded?
1	Load Cell	EUT	Load Cell Term.	0.25	N	N
2	DC Power	EUT	DC Power Supply	>1	N	N

3 Bandwidth

3.1 Test Result

Test Description	Test Specification		Test Result
6 dB Bandwidth	15.247(a)(2)	RSS-247 S5.2 (a) RSS-GEN S6.7	Compliant

3.2 Test Method

The procedures from ANSI C63.10: 2013 clause 11.8 and 558074 D01 15.247 Meas Guidance v05r02 were used to determine the 6dB bandwidth.

Limit

The minimum 6dB bandwidth shall be at least 500 kHz.

3.3 Test Site

SGS EMC Laboratory, Suwanee, GA

Environmental Conditions

Temperature: 22.5 °C

Relative Humidity: 24.8 %

Atmospheric Pressure: 98.6 kPa

3.4 Test Equipment

Test End Date: 15-Jan-2019

Tester: MT

Equipment	Model	Manufacturer	Asset Number	Cal Due Date
RF CABLE (TS8997)	141	HUBER & SUHNER	B095585	25-Jul-2019
ATTENUATOR, 10DB (TS8997)	10DB	ROHDE & SCHWARZ	B095591	25-Jul-2019
RF SWITCH (TS8997)	OSP	ROHDE & SCHWARZ	15039	15-Dec-2019
POWER METER (TS8997)	OSP-B157	ROHDE & SCHWARZ	15040	15-Dec-2019
SIGNAL ANALYZER (TS8997)	FSV30	ROHDE & SCHWARZ	B085749	1-Nov-2019

Note: The equipment calibration period is 1 year except for the FSV which is on a 2-year cycle.

3.5 Test Data

Channel	Frequency (MHz)	6dB Bandwidth (kHz)	Limit Min (kHz)	Result
0	2402	752.5	500	Pass
19	2440	752.5	500	Pass
39	2480	732.7	500	Pass

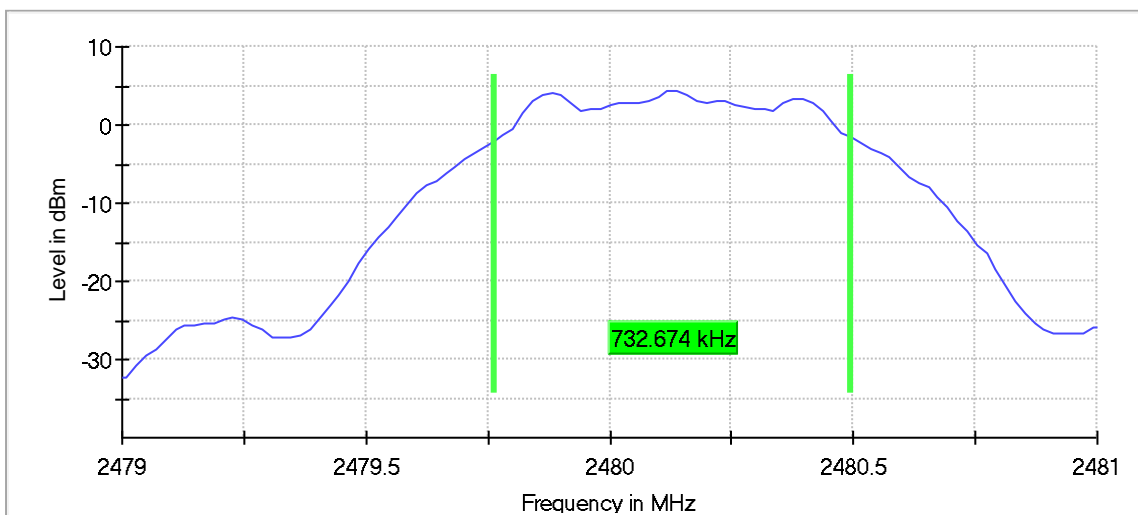
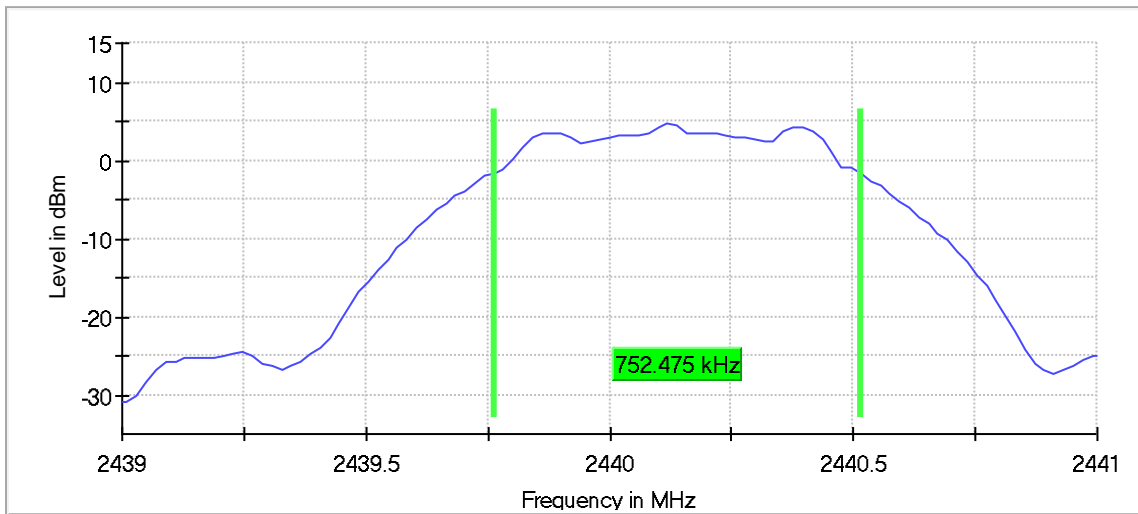
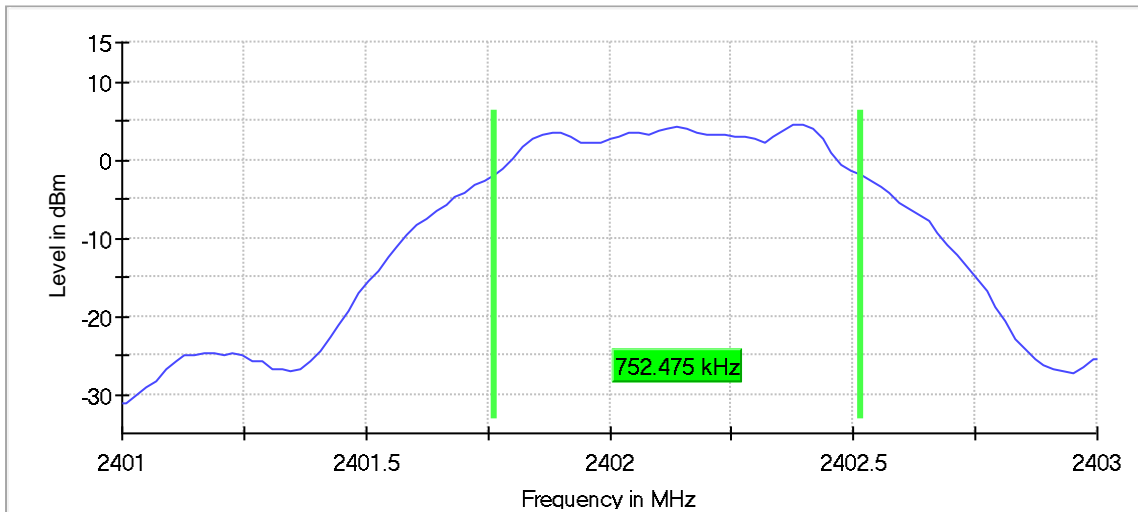

4 Output Power

4.1 Test Result

Test Description	Test Specification		Test Result
Output Power	15.247(b)(3)	RSS-247 S5.4 (d)	Compliant

4.2 Test Method

Fundamental maximum conducted (average) output power measurements were recorded using the procedures from ANSI C63.10: 2013 clause 11.9.2 and KDB 558074 D01 15.247 Meas Guidance v05r02.

Limit

For systems using digital modulation in the 902-928 MHz, 2400-2483.5 MHz, and 5725-5850 MHz bands: 1 Watt. For using antennas with greater than 6dBi of gain, the limit is reduced in dB by the amount the gain exceeds 6dBi (e.g. for a 7.4dBi antenna, the limit is reduced from 30dBm to 28.6dBm).

4.3 Test Site

SGS EMC Laboratory, Suwanee, GA

Environmental Conditions

Temperature: 22.5 °C
 Relative Humidity: 24.8 %
 Atmospheric Pressure: 98.6 kPa

4.4 Test Equipment

Test End Date: 15-Jan-2019

Tester: MT

Equipment	Model	Manufacturer	Asset Number	Cal Due Date
RF CABLE (TS8997)	141	HUBER & SUHNER	B095585	25-Jul-2019
ATTENUATOR, 10DB (TS8997)	10DB	ROHDE & SCHWARZ	B095591	25-Jul-2019
RF SWITCH (TS8997)	OSP	ROHDE & SCHWARZ	15039	15-Dec-2019
POWER METER (TS8997)	OSP-B157	ROHDE & SCHWARZ	15040	15-Dec-2019
SIGNAL ANALYZER (TS8997)	FSV30	ROHDE & SCHWARZ	B085749	1-Nov-2019

Note: The equipment calibration period is 1 year except for the FSV which is on a 2-year cycle.

4.5 Test Data

Channel	Frequency (MHz)	RMS Power (dBm)	Limit Max (dBm)	Result
0	2402	4.63	30	Pass
19	2440	4.47	30	Pass
39	2480	4.26	30	Pass

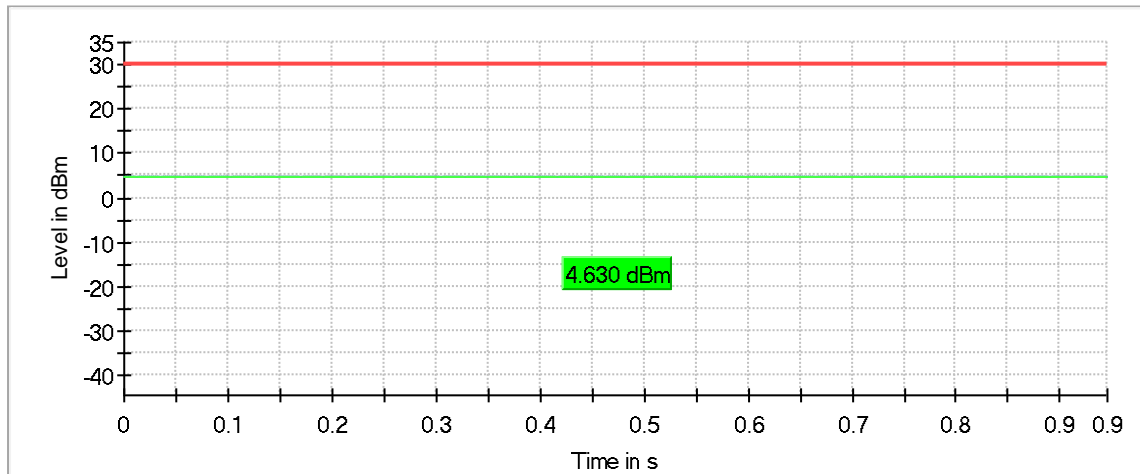

— Gated Trace — Overall — Limit

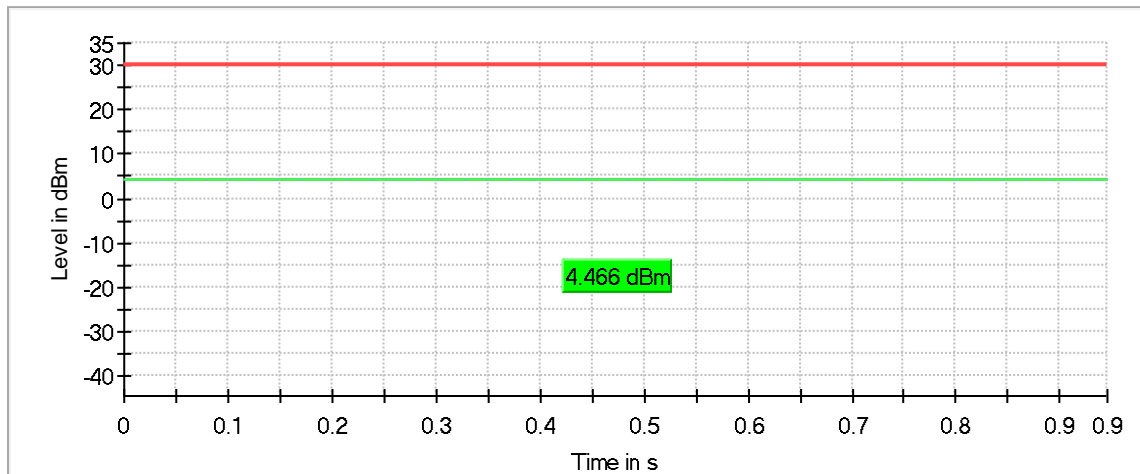

— Gated Trace — Overall — Limit

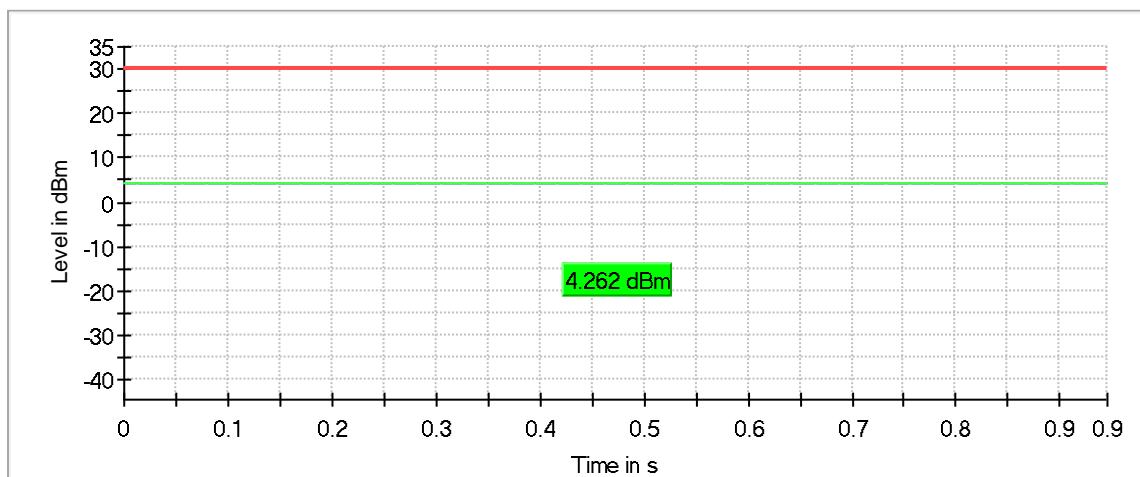

— Gated Trace — Overall — Limit

5 Power Spectral Density

5.1 Test Result

Test Description	Test Specification		Test Result
Power Spectral Density	15.247(e)	RSS-247 S5.2 (b)	Compliant

5.2 Test Method

Power spectral density measurements were recorded using the procedures from ANSI C63.10: 2013 clause 11.10 and KDB 558074 D01 15.247 Meas Guidance v05r02.

Limit

The maximum limit is 8 dBm / 3 kHz.

5.3 Test Site

SGS EMC Laboratory, Suwanee, GA

Environmental Conditions

Temperature: 22.5 °C
 Relative Humidity: 24.8 %
 Atmospheric Pressure: 98.6 kPa

5.4 Test Equipment

Test End Date: 15-Jan-2019

Tester: MT

Equipment	Model	Manufacturer	Asset Number	Cal Due Date
RF CABLE (TS8997)	141	HUBER & SUHNER	B095585	25-Jul-2019
ATTENUATOR, 10DB (TS8997)	10DB	ROHDE & SCHWARZ	B095591	25-Jul-2019
RF SWITCH (TS8997)	OSP	ROHDE & SCHWARZ	15039	15-Dec-2019
POWER METER (TS8997)	OSP-B157	ROHDE & SCHWARZ	15040	15-Dec-2019
SIGNAL ANALYZER (TS8997)	FSV30	ROHDE & SCHWARZ	B085749	1-Nov-2019

Note: The equipment calibration period is 1 year except for the FSV which is on a 2-year cycle.

5.5 Test Data

Channel	Frequency (MHz)	PSD (dBm/3kHz)	Limit Max (dBm/3kHz)	Result
0	2402	-10.6	8	Pass
19	2440	-10.4	8	Pass
39	2480	-11.0	8	Pass

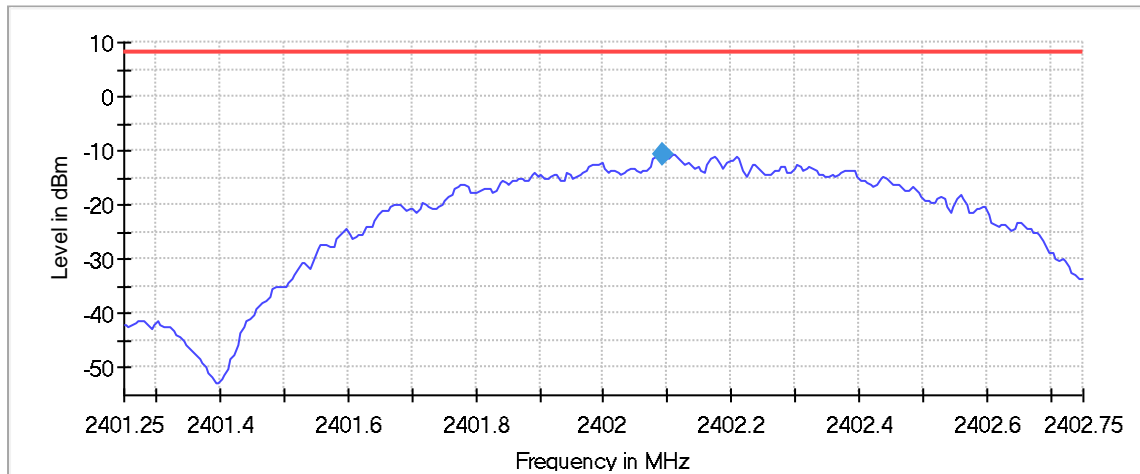

— Limit — Sum Level ◆ PSD

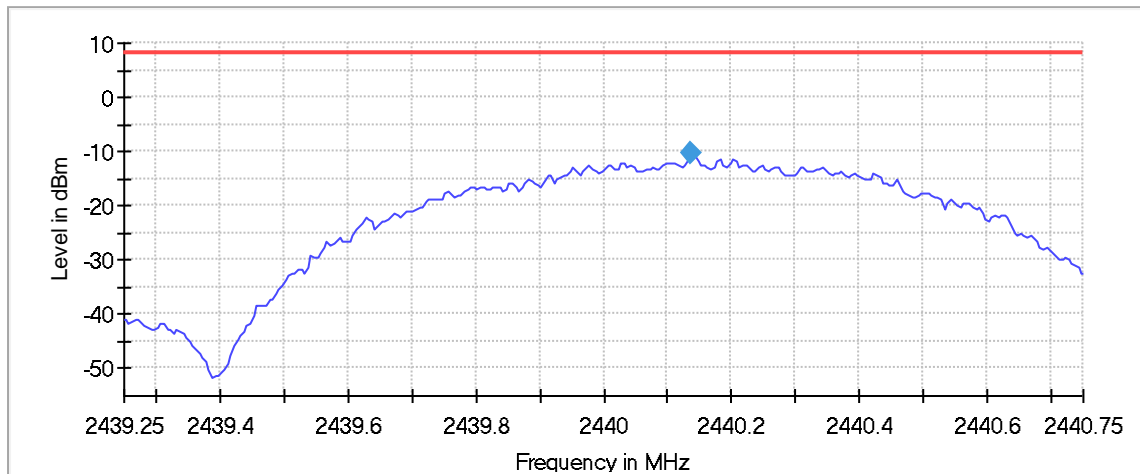

— Limit — Sum Level ◆ PSD

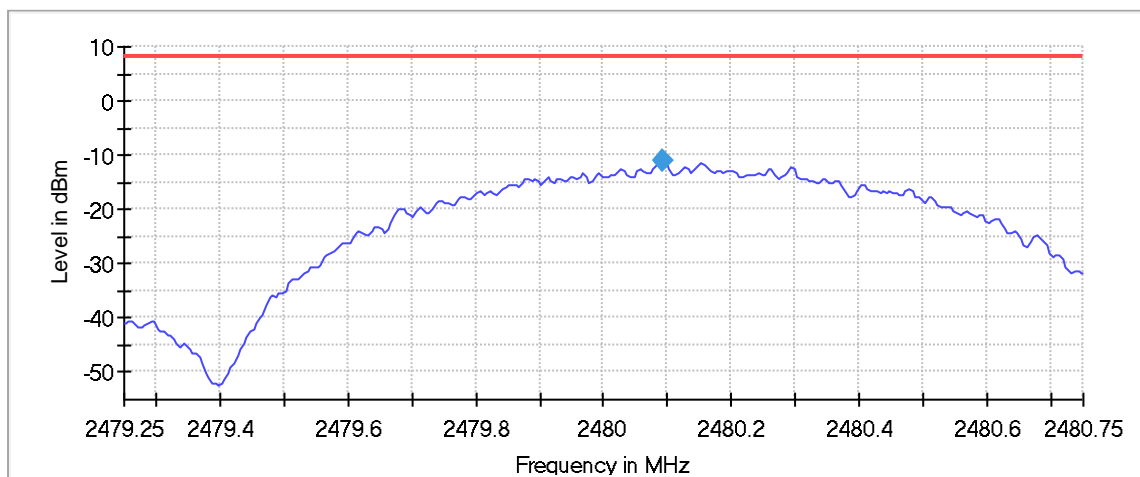

— Limit — Sum Level ◆ PSD

6 Conducted Spurious Emissions / Band Edge

6.1 Test Result

Test Description	Test Specification		Test Result
Conducted Spurious Emissions	15.247(d)	RSS-247 S5.5	Compliant

6.2 Test Method

Spurious emissions in non-restricted frequency bands were recorded using the methods defined in ANSI C63.10: 2013 clause 11.11 and KDB 558074 D01 15.247 Meas Guidance v05r02.

Limit

Because the maximum conducted average output power was used to determine compliance with the output power limits, the limit in any 100 kHz band outside of the authorized band is 30 dB below the maximum in-band peak level.

6.3 Test Site

SGS EMC Laboratory, Suwanee, GA

Environmental Conditions	Conducted Spurious Emissions	Band Edge
Temperature:	22.2 °C	22.5 °C
Relative Humidity:	41.7 %	24.8 %
Atmospheric Pressure:	98.0 kPa	98.6 kPa

6.4 Test Equipment

Conducted Spurious Emissions

Test End Date: 8-Jan-2019

Tester: MT

Equipment	Model	Manufacturer	Asset Number	Cal Due Date
RF CABLE	SF102	HUBER & SUHNER	B079823	25-Jul-2019
ATTENUATOR, 10DB	BW-S10W2	MINI-CIRCUITS	15033	CNR
SIGNAL ANALYZER (TS8997)	FSV30	ROHDE & SCHWARZ	B085749	1-Nov-2019

Band Edge

Test End Date: 15-Jan-2019

Tester: MT

Equipment	Model	Manufacturer	Asset Number	Cal Due Date
RF CABLE (TS8997)	141	HUBER & SUHNER	B095585	25-Jul-2019
ATTENUATOR, 10DB (TS8997)	10DB	ROHDE & SCHWARZ	B095591	25-Jul-2019
RF SWITCH (TS8997)	OSP	ROHDE & SCHWARZ	15039	15-Dec-2019
POWER METER (TS8997)	OSP-B157	ROHDE & SCHWARZ	15040	15-Dec-2019
SIGNAL ANALYZER (TS8997)	FSV30	ROHDE & SCHWARZ	B085749	1-Nov-2019

Note: The equipment calibration period is 1 year except for the FSV which is on a 2-year cycle.

6.5 Test Data – DTS Band Edge

BLE - Lower band edge:

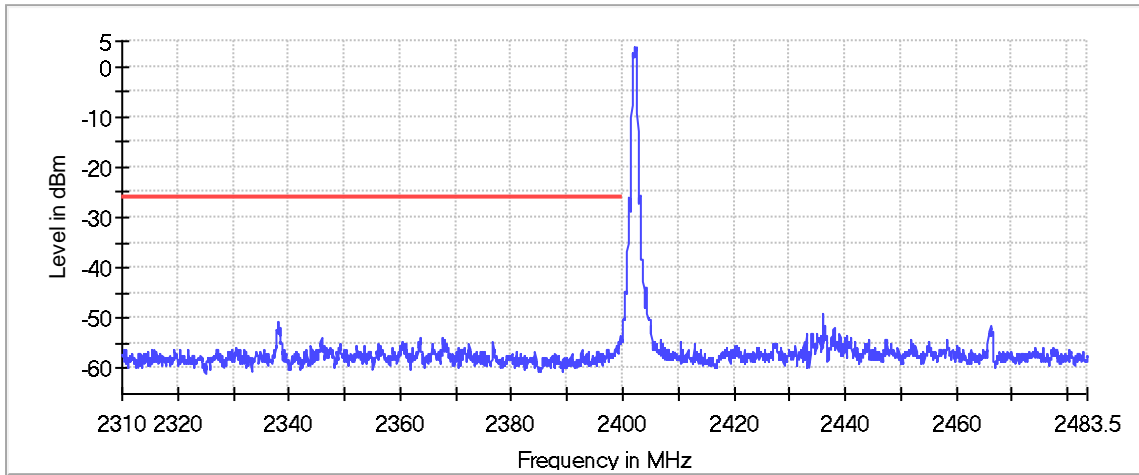

— Limit — Sum Level × Fail

BLE - Upper band edge:

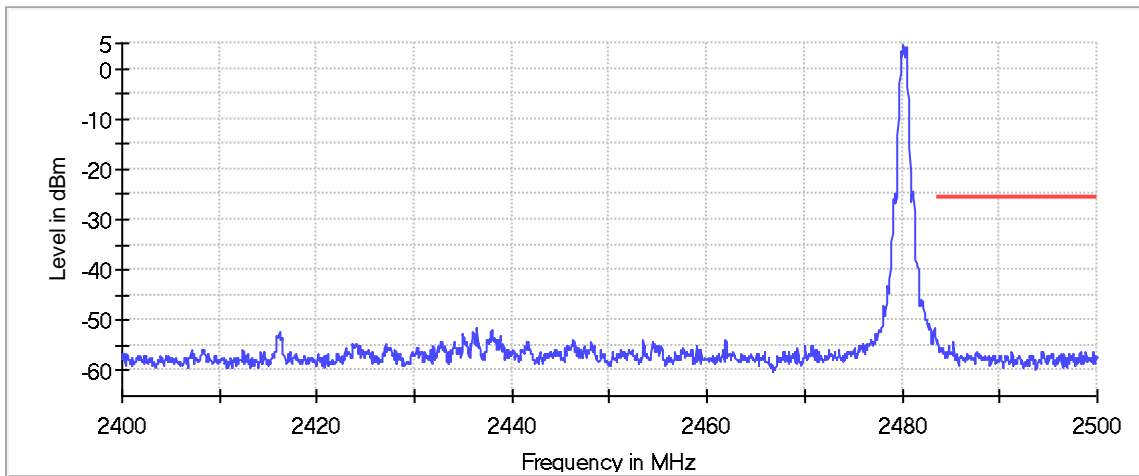

— Limit — Sum Level × Fail

6.6 Test Data – Conducted Spurious Emissions

Conducted Spurs – Channel 0

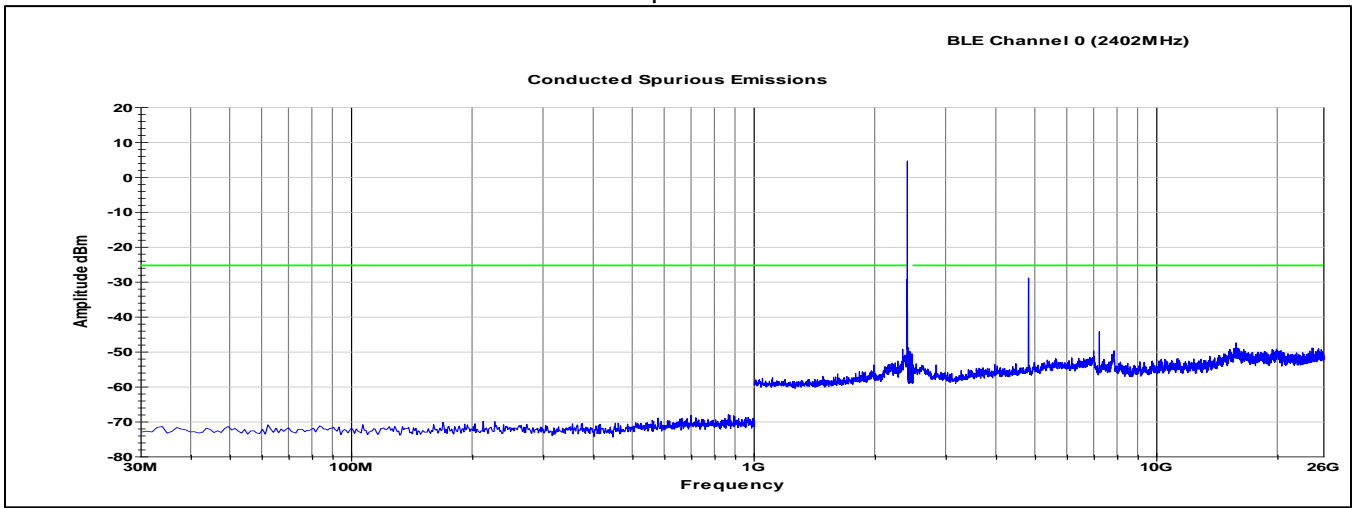

Conducted Spurs – Channel 19

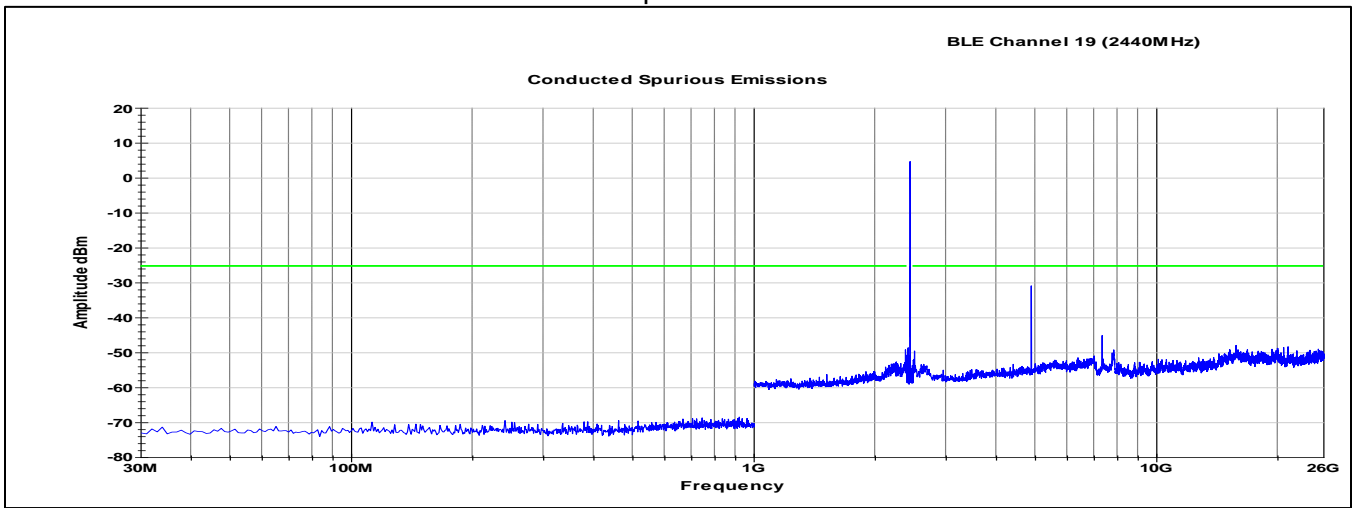

Conducted Spurs – Channel 39

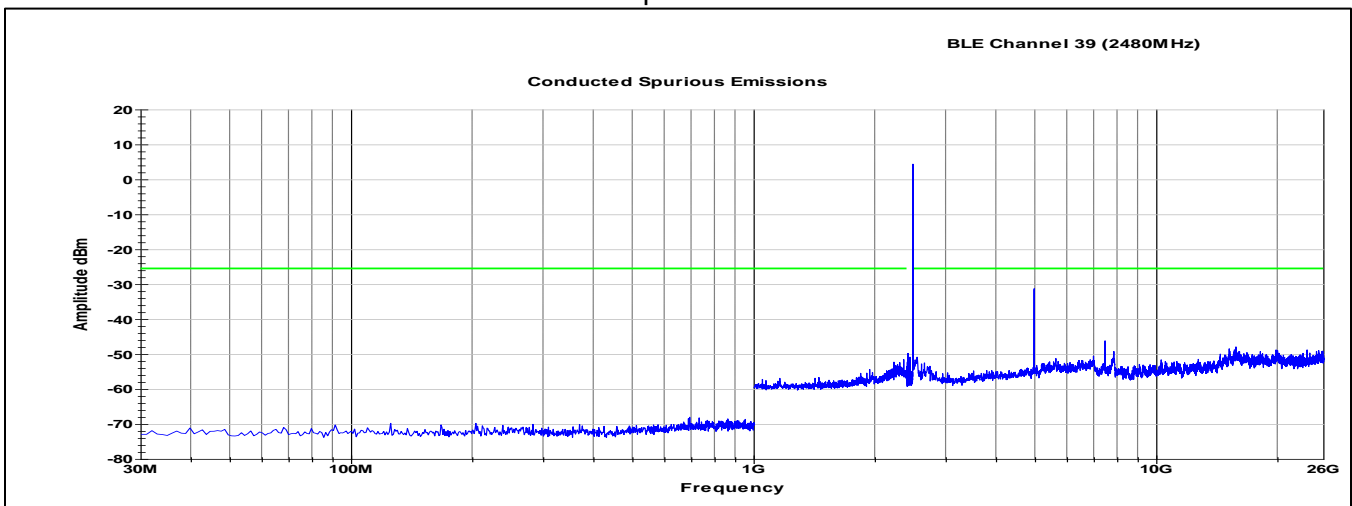

7 Field Strength of Spurious Radiation

7.1 Test Result

Test Description	Test Specification		Test Result
Spurious Emissions	15.247(d) 15.205, 15.209	RSS-247 S5.5 RSS-GEN S8.9, S8.10	Compliant

7.2 Test Method

The measurement methods defined in ANSI C63.10: 2013 and KDB 558074 D01 15.247 Meas Guidance v05r02 were used.

Lowest, middle and highest channels were investigated – the device was commanded to continuously transmit on channels 0, 19 and 39.

Two different models were tested: one with an external load cell cable attached (Dynamometer) and one without an external cable (Inclinometer / Rod Rotation Monitor). The worst-case results are reported for each frequency range.

The EUT has two selectable PCB trace antennas. Measurements were performed using both antennas and the worst-case results are reported.

Test distance:

- 9k to 30 MHz – Near field prescan to determine if there were any emissions
- 30 to 1000 MHz - The EUT to measurement antenna distance was 3 meters
- 1 to 18 GHz - The EUT to measurement antenna distance was 3 meters
- 18 to 26 GHz - The EUT to measurement antenna distance was 3 meters

Limits within restricted bands of operation:

Frequency	Limits ⁽¹⁾		Peak Limits dBuV/m
	Microvolts/m	dBuV/m	
30 - 88 MHz	100	40 ⁽²⁾	--
88 - 216 MHz	150	43.5 ⁽²⁾	--
216 - 960 MHz	200	46 ⁽²⁾	--
960 - 1000 MHz	500	54 ⁽²⁾	--
1 - 40 GHz	500	54 ⁽³⁾	74

(1) These limits are applicable to emissions outside of the intentional transmit frequency band.

(2) Quasi-peak limit

(3) Average limit

7.3 Test Site

10m Absorber Lined Shielded Enclosure (ALSE), Suwanee, GA

Environmental Conditions	30-1000MHz	1-18GHz	18-26GHz
Temperature:	22.5 °C	21.7 to 22.9 °C	22.6 to 23.2 °C
Relative Humidity:	51.5 %	24.1 to 48.8 %	31.1 to 31.9 %
Atmospheric Pressure:	97.8 kPa	97.1 to 99.1 kPa	98.4 to 99.1 kPa

7.4 Test Equipment

30-1000MHz

Test End Date: 10-Jun-2019

Tester: PL

Equipment	Model	Manufacturer	Asset Number	Cal Due Date
ANTENNA, BILOG	JB6	SUNOL	B079690	11-Dec-2019
RF CABLE	SF106	HUBER & SUHNER	B079712	24-Jul-2019
RF CABLE	SF106	HUBER & SUHNER	B079713	24-Jul-2019
RF CABLE	SF106	HUBER & SUHNER	B079659	23-Jul-2019
RF CABLE	104PE	HUBER & SUHNER	B079793	24-Jul-2019
LOW NOISE AMPLIFIER	TS-PR18	ROHDE & SCHWARZ	B094463	2-May-2020
EMI TEST RECEIVER	ESU8	ROHDE & SCHWARZ	B085759	17-Aug-2019

1-3GHz

Test End Date: 7-Jun-2019

Tester: PL

Equipment	Model	Manufacturer	Asset Number	Cal Due Date
ANTENNA, DRG HORN (MEDIUM)	3117	ETS LINDGREN	B079691	10-Aug-2020
RF CABLE	SF102	HUBER & SUHNER	B079822	25-Jul-2019
RF CABLE	SUCOFLEX 100	HUBER & SUHNER	B108523	24-Jul-2019
LOW NOISE AMPLIFIER	TS-PR18	ROHDE & SCHWARZ	15003	24-Jan-2020
EMI TEST RECEIVER	ESU40	ROHDE & SCHWARZ	B079629	2-Jul-2019

3-18GHz

Test End Date: 8-Feb-2019

Tester: MT

Equipment	Model	Manufacturer	Asset Number	Cal Due Date
ANTENNA, DRG HORN (MEDIUM)	3117	ETS LINDGREN	B079699	2-Jul-2019
RF CABLE	SF106	HUBER & SUHNER	B079661	23-Jul-2019
RF CABLE	SUCOFLEX 100	HUBER & SUHNER	B108523	24-Jul-2019
LOW NOISE AMPLIFIER	TS-PR18	ROHDE & SCHWARZ	B094463	6-Mar-2019
EMI TEST RECEIVER	ESU40	ROHDE & SCHWARZ	B079629	2-Jul-2019
FILTER, HIGH PASS (>2800MHZ)	HPM50111	MICRO-TRONICS	B085747	26-Jul-2019

18-26GHz

Test End Date: 8-Feb-2019

Tester: MT

Equipment	Model	Manufacturer	Asset Number	Cal Due Date
ANTENNA, HORN (SMALL)	LB-180400-20-C-KF	A-INFO	15007	30-Mar-2019
RF CABLE	SF102	HUBER & SUHNER	B079822	25-Jul-2019
RF CABLE	SF102	HUBER & SUHNER	B079823	25-Jul-2019
LOW NOISE AMPLIFIER	NSP1840-HG	MITEQ	B087572	27-Jul-2019
EMI TEST RECEIVER	ESU40	ROHDE & SCHWARZ	B079629	2-Jul-2019

Note: The equipment calibration period is 1 year.

7.5 Test Data – Peak Plots

No emissions were detected in the range 9kHz to 30MHz.

BLE Channel 0
Vertical Plot (30-1000MHz)

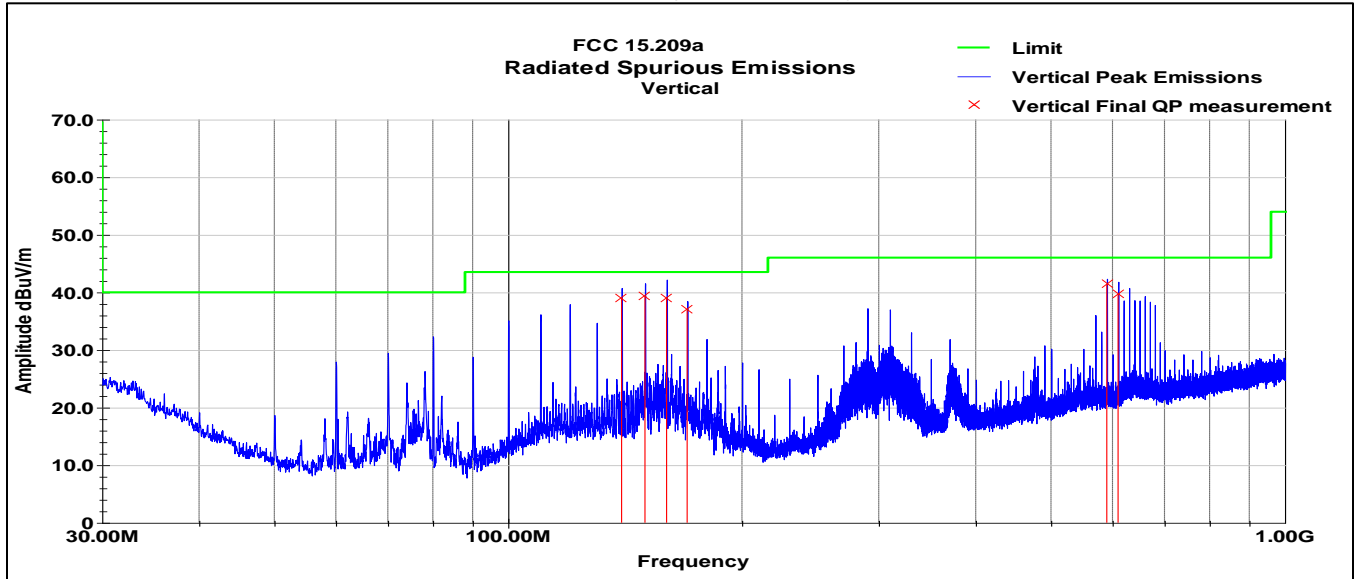

Vertical Data (30-1000MHz)

Frequency MHz	Raw QP (dBuV)	Polarity (V/H)	Azimuth (degrees)	Height (cm)	AF (dB/m)	Loss (dB)	Amp (dB)	QP Value (dBuV/m)	Limit (dBuV/m)	Margin (dB)
139.98	59.0	V	278.0	100.0	13.2	1.3	34.4	39.0	43.5	-4.5
150.02	59.6	V	238.0	106.0	12.8	1.3	34.4	39.4	43.5	-4.2
159.96	59.3	V	239.0	100.0	12.8	1.3	34.3	39.1	43.5	-4.4
170.00	57.9	V	191.0	100.0	12.1	1.4	34.3	37.0	43.5	-6.5
589.96	52.6	V	339.0	100.0	19.5	2.6	33.3	41.5	46.0	-4.5
609.99	50.5	V	298.0	100.0	19.8	2.7	33.3	39.7	46.0	-6.3
QP Value = Level + AF + CL - Amp										
Margin = QP Value - Limit										

BLE Channel 0
Horizontal Plot (30-1000MHz)

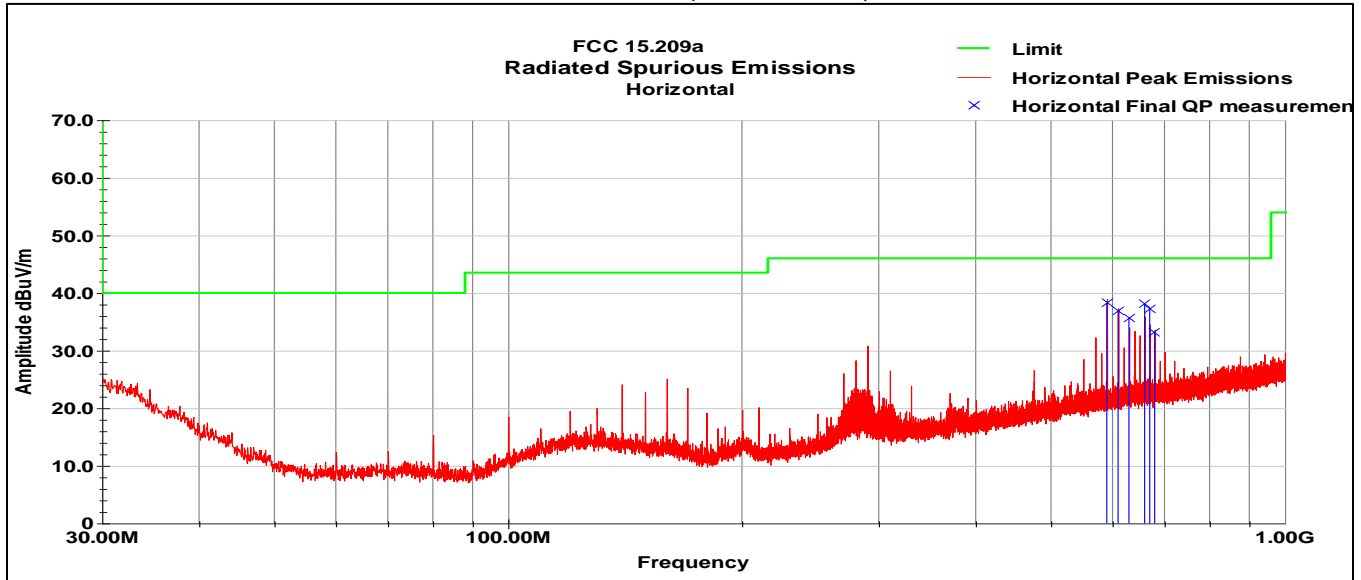

Horizontal Data (30-1000MHz)

Frequency MHz	Raw QP (dBuV)	Polarity (V/H)	Azimuth (degrees)	Height (cm)	AF (dB/m)	Loss (dB)	Amp (dB)	QP Value (dBuV/m)	Limit (dBuV/m)	Margin (dB)
589.96	49.4	H	291.0	164.0	19.5	2.6	33.3	38.2	46.0	-7.8
609.99	47.6	H	278.0	166.0	19.8	2.7	33.3	36.8	46.0	-9.2
629.97	46.0	H	112.0	147.0	20.1	2.7	33.3	35.6	46.0	-10.4
660.00	48.1	H	97.0	142.0	20.5	2.8	33.3	38.1	46.0	-7.9
669.99	47.3	H	101.0	138.0	20.5	2.8	33.3	37.3	46.0	-8.7
679.98	43.1	H	302.0	250.0	20.6	2.8	33.3	33.2	46.0	-12.8
QP Value = Level + AF + CL - Amp										
Margin = QP Value - Limit										

BLE Channel 19
Vertical Plot (30-1000MHz)

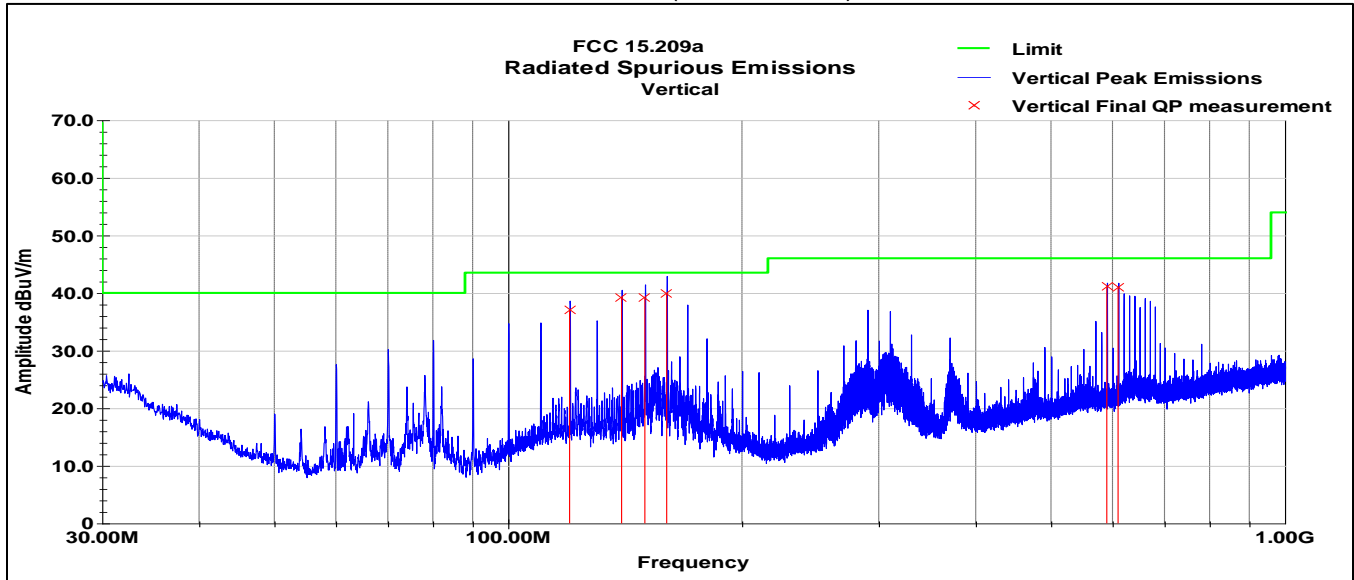

Vertical Data (30-1000MHz)

Frequency MHz	Raw QP (dBuV)	Polarity (V/H)	Azimuth (degrees)	Height (cm)	AF (dB/m)	Loss (dB)	Amp (dB)	QP Value (dBuV/m)	Limit (dBuV/m)	Margin (dB)
120.00	56.7	V	177.0	100.0	13.7	1.2	34.5	37.1	43.5	-6.4
139.98	59.2	V	290.0	100.0	13.2	1.3	34.4	39.3	43.5	-4.3
149.97	59.5	V	289.0	100.0	12.8	1.3	34.4	39.2	43.5	-4.3
160.01	60.1	V	198.0	100.0	12.8	1.3	34.3	40.0	43.5	-3.6
589.96	52.2	V	339.0	100.0	19.5	2.6	33.3	41.1	46.0	-4.9
609.99	51.7	V	233.0	106.0	19.8	2.7	33.3	40.9	46.0	-5.1
QP Value = Level + AF + CL - Amp										
Margin = QP Value - Limit										

BLE Channel 19
Horizontal Plot (30-1000MHz)

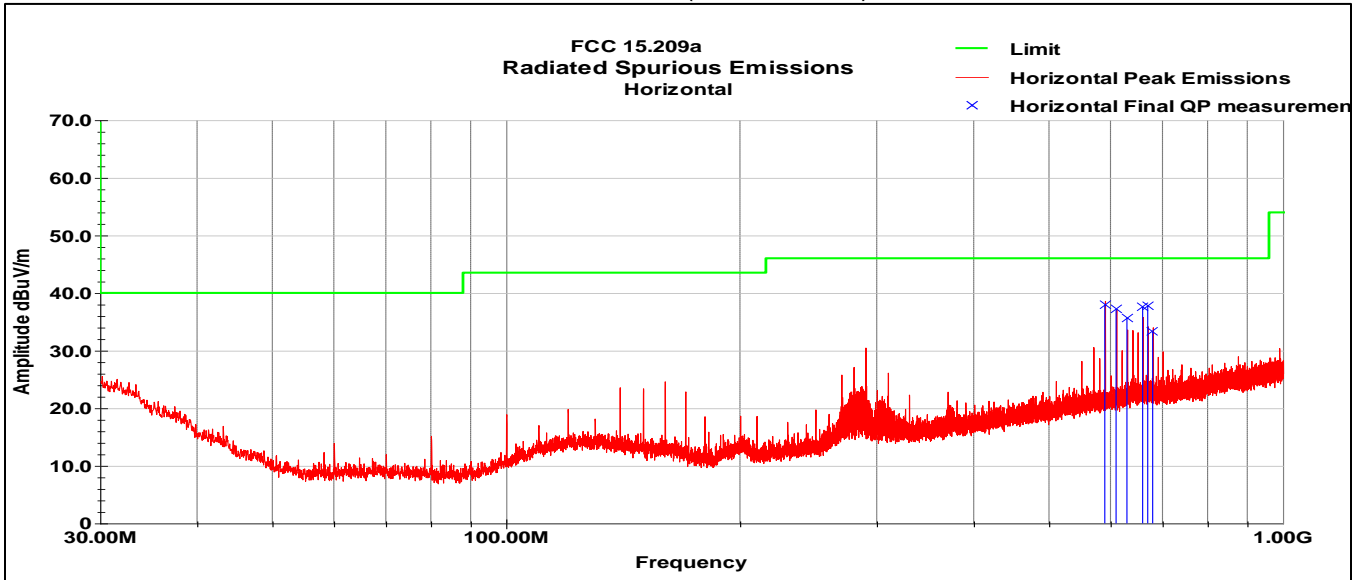

Horizontal Data (30-1000MHz)

Frequency MHz	Raw QP (dBuV)	Polarity (V/H)	Azimuth (degrees)	Height (cm)	AF (dB/m)	Loss (dB)	Amp (dB)	QP Value (dBuV/m)	Limit (dBuV/m)	Margin (dB)
589.96	49.2	H	290.0	158.0	19.5	2.6	33.3	38.0	46.0	-8.0
609.99	48.0	H	277.0	154.0	19.8	2.7	33.3	37.2	46.0	-8.9
629.97	46.1	H	114.0	146.0	20.1	2.7	33.3	35.7	46.0	-10.3
660.00	47.6	H	94.0	143.0	20.5	2.8	33.3	37.6	46.0	-8.4
669.99	47.8	H	109.0	138.0	20.5	2.8	33.3	37.8	46.0	-8.2
679.98	43.1	H	289.0	248.0	20.6	2.8	33.3	33.3	46.0	-12.8
QP Value = Level + AF + CL - Amp										
Margin = QP Value - Limit										

BLE Channel 39
Vertical Plot (30-1000MHz)

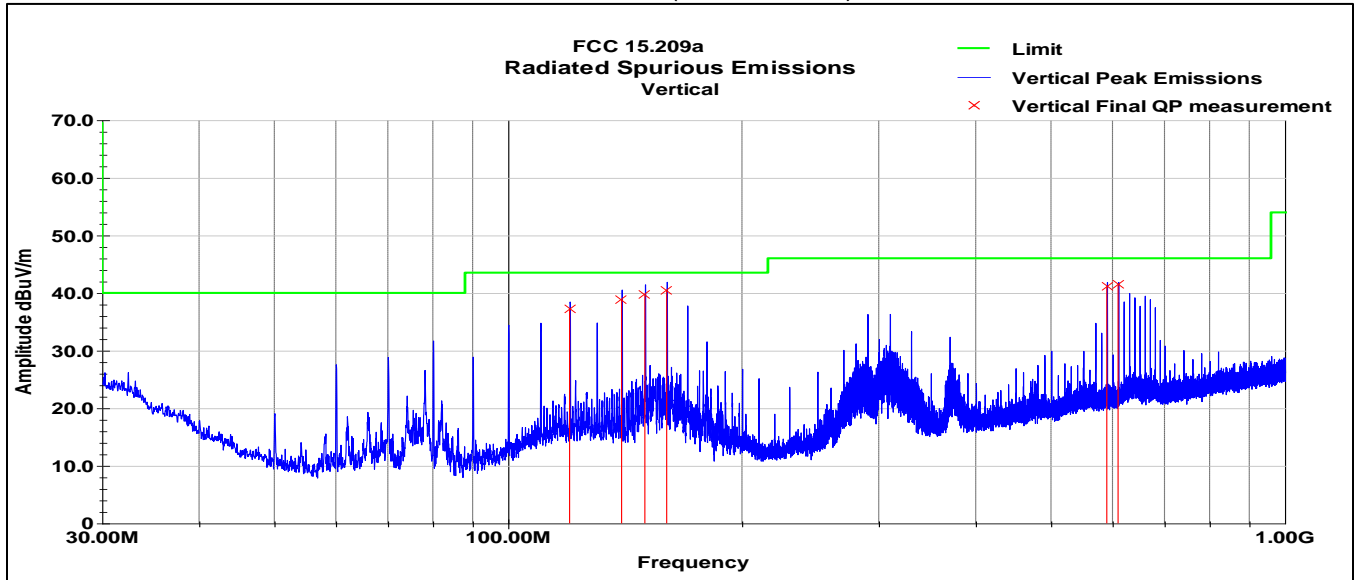

Vertical Data (30-1000MHz)

Frequency MHz	Raw QP (dBuV)	Polarity (V/H)	Azimuth (degrees)	Height (cm)	AF (dB/m)	Loss (dB)	Amp (dB)	QP Value (dBuV/m)	Limit (dBuV/m)	Margin (dB)
120.00	56.9	V	266.0	100.0	13.7	1.2	34.5	37.3	43.5	-6.3
139.98	58.8	V	225.0	100.0	13.2	1.3	34.4	38.9	43.5	-4.7
149.97	60.0	V	222.0	101.0	12.8	1.3	34.4	39.7	43.5	-3.8
160.01	60.6	V	228.0	101.0	12.8	1.3	34.3	40.4	43.5	-3.1
589.96	52.3	V	312.0	101.0	19.5	2.6	33.3	41.1	46.0	-4.9
609.99	52.3	V	235.0	102.0	19.8	2.7	33.3	41.5	46.0	-4.5
QP Value = Level + AF + CL - Amp										
Margin = QP Value - Limit										

BLE Channel 39
Horizontal Plot (30-1000MHz)

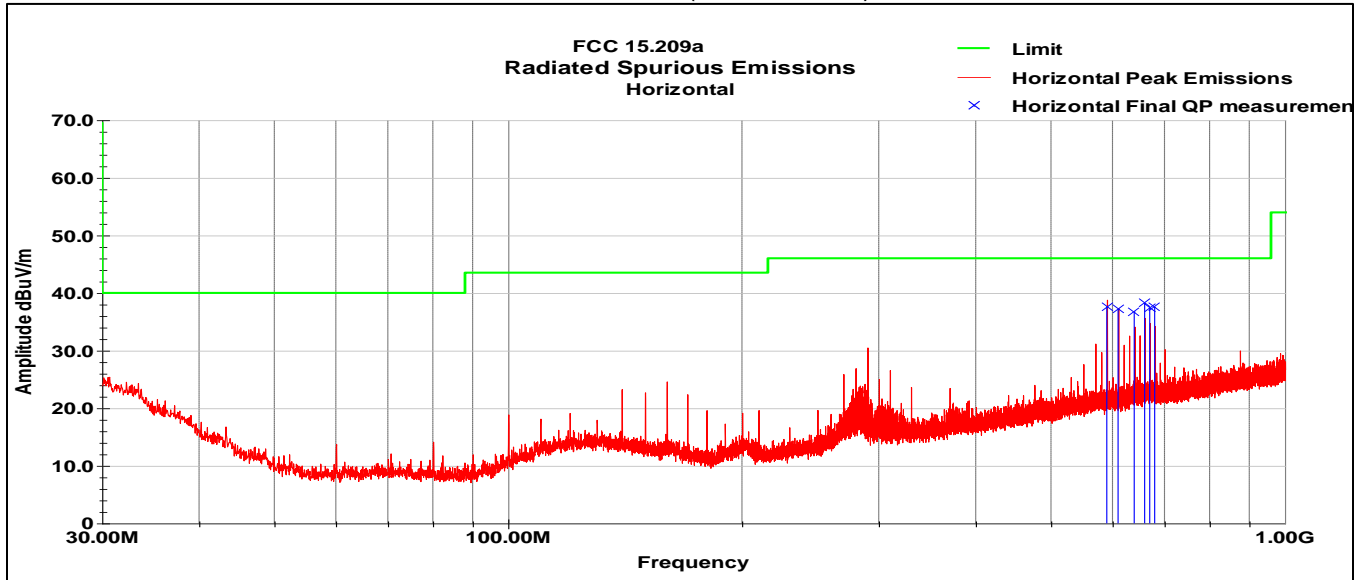

Horizontal Data (30-1000MHz)

Frequency MHz	Raw QP (dBuV)	Polarity (V/H)	Azimuth (degrees)	Height (cm)	AF (dB/m)	Loss (dB)	Amp (dB)	QP Value (dBuV/m)	Limit (dBuV/m)	Margin (dB)
589.96	48.8	H	305.0	161.0	19.5	2.6	33.3	37.7	46.0	-8.4
609.99	48.0	H	278.0	158.0	19.8	2.7	33.3	37.2	46.0	-8.8
639.96	47.0	H	88.0	147.0	20.3	2.8	33.3	36.8	46.0	-9.2
659.95	48.3	H	108.0	139.0	20.5	2.8	33.3	38.3	46.0	-7.7
669.99	47.4	H	108.0	137.0	20.5	2.8	33.3	37.4	46.0	-8.6
679.98	47.4	H	102.0	131.0	20.6	2.8	33.3	37.6	46.0	-8.4
QP Value = Level + AF + CL - Amp										
Margin = QP Value - Limit										

BLE Channel 0
Vertical Plot (1-3GHz)

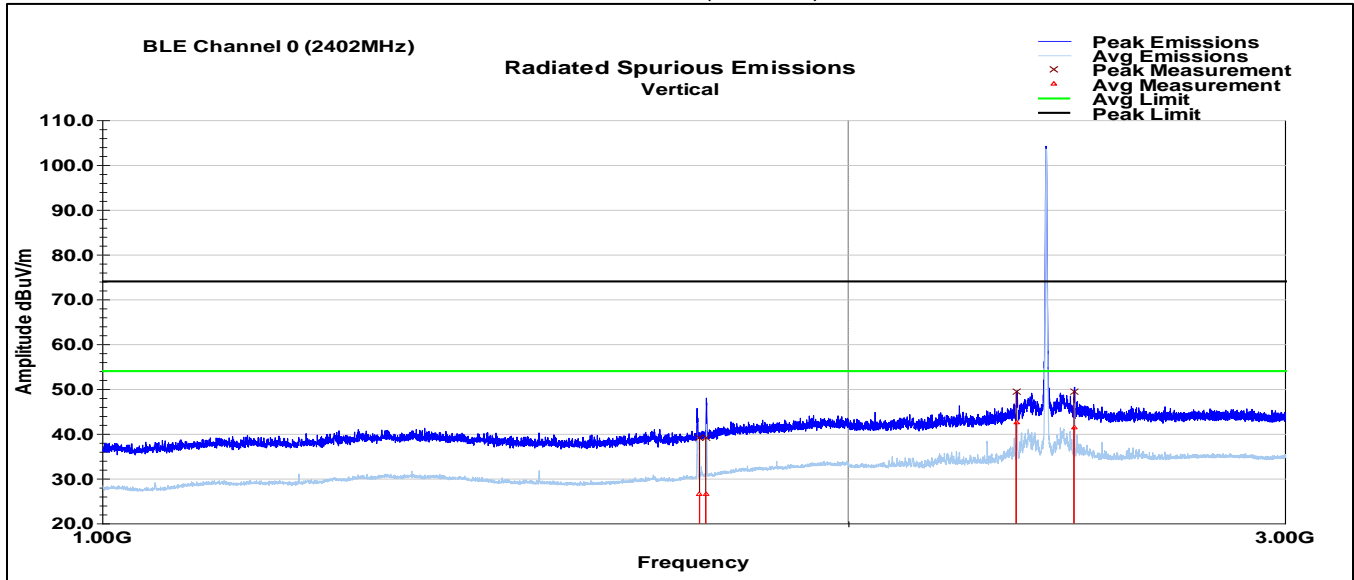

Vertical Peak Data (1-3GHz)

Frequency MHz	Raw Pk dBuV	Polarity (V/H)	Azimuth (degrees)	Height (cm)	AF (dB/m)	Loss (dB)	Amp (dB)	Final Pk dBuV/m	Limit dBuV/m	Margin dB
1741.96	42.1	V	329.0	175.0	29.5	2.1	34.5	39.2	74.0	-34.8
1751.96	42.0	V	96.0	182.0	29.7	2.1	34.5	39.2	74.0	-34.8
2337.76	49.6	V	180.0	100.0	31.8	2.4	34.4	49.3	74.0	-24.7
2466.68	48.9	V	339.0	100.0	32.5	2.5	34.4	49.5	74.0	-24.5
Final PK = Raw PK + AF + Loss - Amp										
Margin = Final PK - Limit										

Vertical Average Data (1-3GHz)

Frequency MHz	Raw Avg dBuV	Polarity (V/H)	Azimuth (degrees)	Height (cm)	AF (dB/m)	Loss (dB)	Amp (dB)	Final Avg dBuV/m	Limit (dBuV/m)	Margin (dB)
1741.96	29.4	V	329.0	175.0	29.5	2.1	34.5	26.5	54.0	-27.5
1751.96	29.4	V	96.0	182.0	29.7	2.1	34.5	26.7	54.0	-27.3
2337.76	42.9	V	180.0	100.0	31.8	2.4	34.4	42.6	54.0	-11.4
2466.68	40.9	V	339.0	100.0	32.5	2.5	34.4	41.5	54.0	-12.5
Final Avg = Raw Avg + AF + Loss - Amp										
Margin = Final Avg - Limit										

BLE Channel 0
Horizontal Plot (1-3GHz)

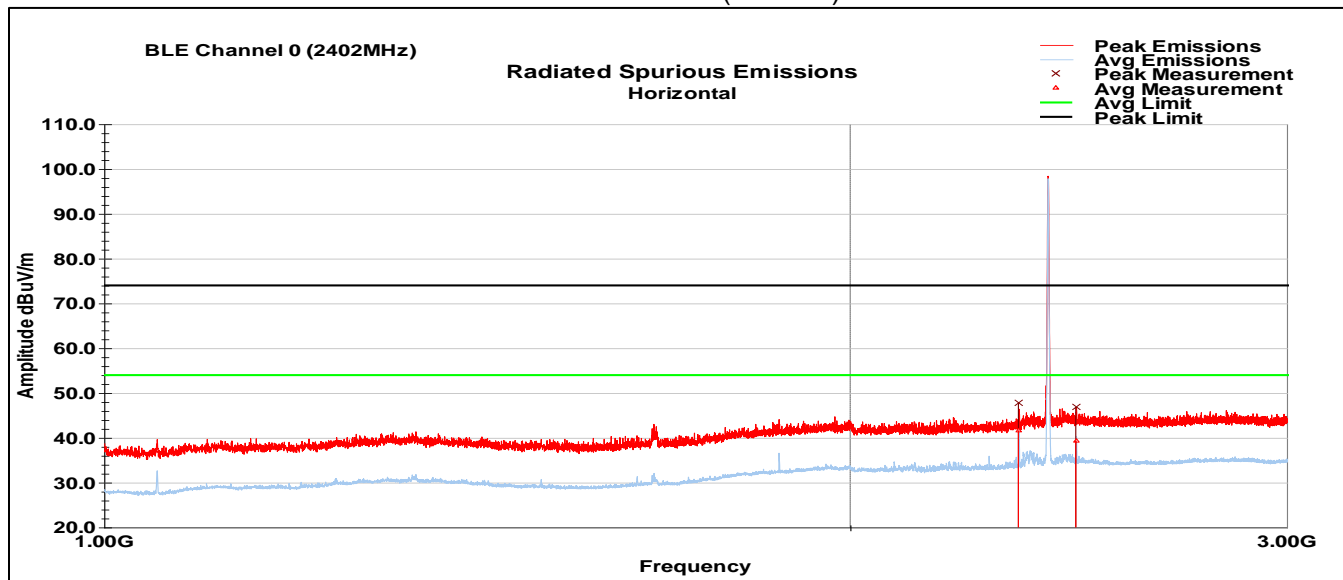

Horizontal Peak Data (1-3GHz)

Frequency MHz	Raw Pk dBuV	Polarity (V/H)	Azimuth (degrees)	Height (cm)	AF (dB/m)	Loss (dB)	Amp (dB)	Final Pk dBuV/m	Limit dBuV/m	Margin dB
2338.12	48.1	H	340.0	233.0	31.8	2.4	34.4	47.9	74.0	-26.1
2466.20	46.3	H	312.0	100.0	32.5	2.5	34.4	46.9	74.0	-27.1
Final PK = Raw PK + AF + CL - Amp										
Margin = Final PK - Limit										

Horizontal Average Data (1-3GHz)

Frequency MHz	Raw Avg dBuV	Polarity (V/H)	Azimuth (degrees)	Height (cm)	AF (dB/m)	Loss (dB)	Amp (dB)	Avg Value dBuV/m	Limit (dBuV/m)	Margin (dB)
2338.12	41.9	H	340.0	233.0	31.8	2.4	34.4	41.6	54.0	-12.4
2466.20	38.8	H	312.0	100.0	32.5	2.5	34.4	39.4	54.0	-14.6
Final Avg = Raw Avg + AF + Loss - Amp										
Margin = Final Avg - Limit										

BLE Channel 19
Vertical Plot (1-3GHz)

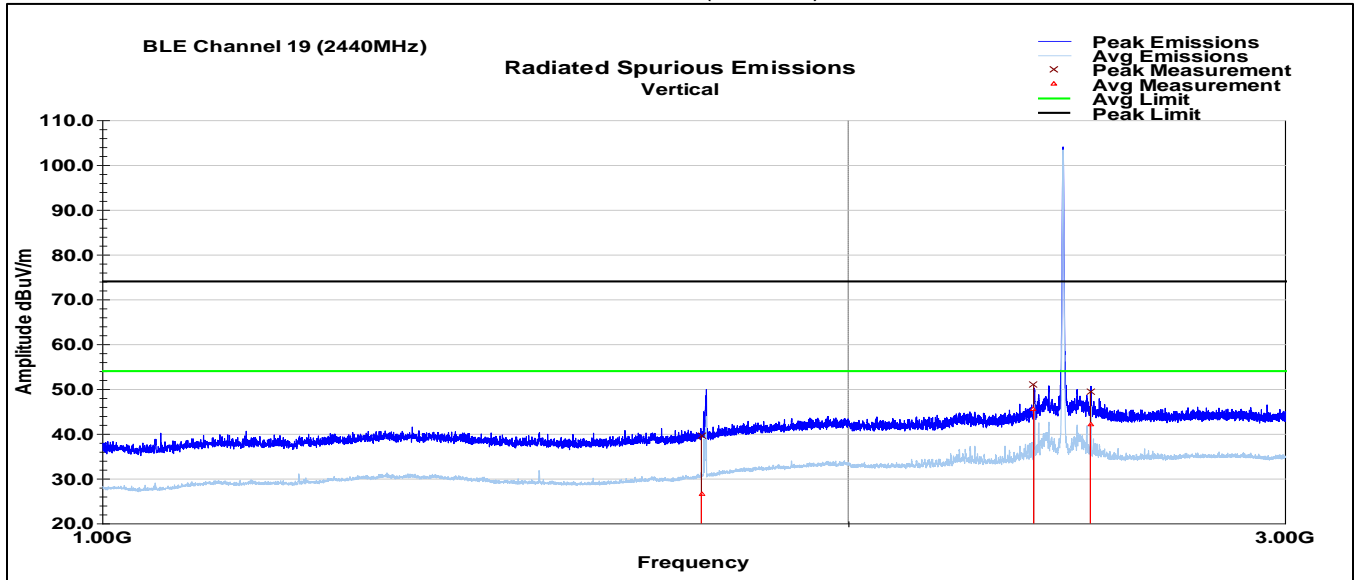

Vertical Peak Data (1-3GHz)

Frequency MHz	Raw Pk dBuV	Polarity (V/H)	Azimuth (degrees)	Height (cm)	AF (dB/m)	Loss (dB)	Amp (dB)	Final Pk dBuV/m	Limit dBuV/m	Margin dB
1745.00	42.5	V	247.0	159.0	29.5	2.1	34.5	39.5	74.0	-34.5
2375.96	51.0	V	97.0	151.0	32.0	2.4	34.4	50.9	74.0	-23.1
2504.48	48.9	V	321.0	102.0	32.6	2.5	34.4	49.5	74.0	-24.5
Final PK = Raw PK + AF + Loss - Amp										
Margin = Final PK - Limit										

Vertical Average Data (1-3GHz)

Frequency MHz	Raw Avg dBuV	Polarity (V/H)	Azimuth (degrees)	Height (cm)	AF (dB/m)	Loss (dB)	Amp (dB)	Final Avg dBuV/m	Limit (dBuV/m)	Margin (dB)
1745.00	29.5	V	247.0	159.0	29.5	2.1	34.5	26.6	54.0	-27.4
2375.96	45.5	V	97.0	151.0	32.0	2.4	34.4	45.5	54.0	-8.5
2504.48	41.5	V	321.0	102.0	32.6	2.5	34.4	42.2	54.0	-11.8
Final Avg = Raw Avg + AF + Loss - Amp										
Margin = Final Avg - Limit										

BLE Channel 19
Horizontal Plot (1-3GHz)

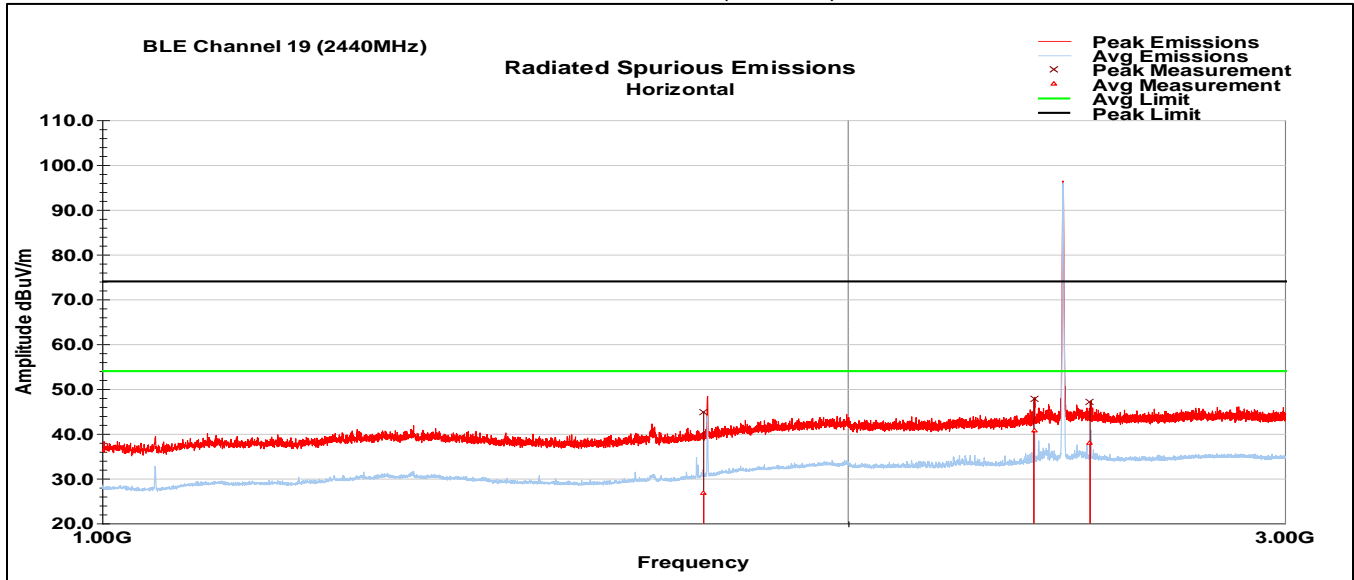

Horizontal Peak Data (1-3GHz)

Frequency MHz	Raw Pk dBuV	Polarity (V/H)	Azimuth (degrees)	Height (cm)	AF (dB/m)	Loss (dB)	Amp (dB)	Final Pk dBuV/m	Limit dBuV/m	Margin dB
1748.72	47.7	H	270.0	175.0	29.6	2.1	34.5	44.9	74.0	-29.1
2376.32	47.9	H	348.0	222.0	32.0	2.4	34.4	47.8	74.0	-26.2
2503.76	46.5	H	308.0	137.0	32.6	2.5	34.4	47.1	74.0	-26.9
Final PK = Raw PK + AF + Loss - Amp										
Margin = Final PK - Limit										

Horizontal Average Data (1-3GHz)

Frequency MHz	Raw Avg dBuV	Polarity (V/H)	Azimuth (degrees)	Height (cm)	AF (dB/m)	Loss (dB)	Amp (dB)	Avg Value dBuV/m	Limit (dBuV/m)	Margin (dB)
1748.72	29.6	H	270.0	175.0	29.6	2.1	34.5	26.7	54.0	-27.3
2376.32	40.6	H	348.0	222.0	32.0	2.4	34.4	40.6	54.0	-13.4
2503.76	37.4	H	308.0	137.0	32.6	2.5	34.4	38.1	54.0	-15.9
Final Avg = Raw Avg + AF + Loss - Amp										
Margin = Final Avg - Limit										

BLE Channel 39
Vertical Plot (1-3GHz)

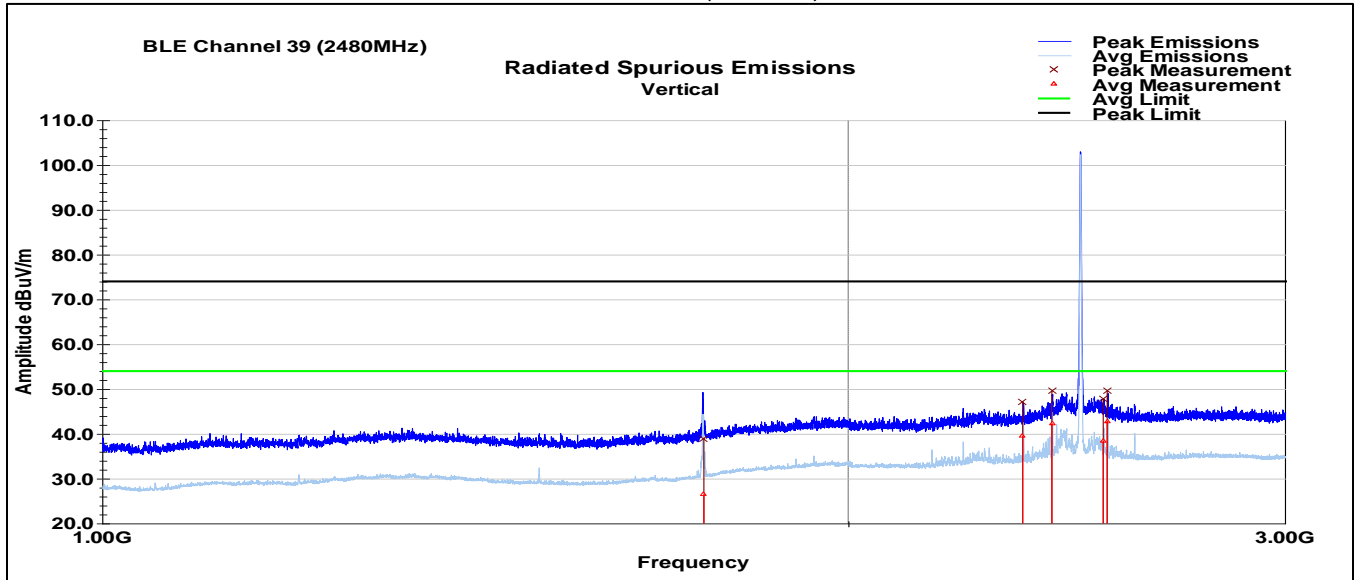

Vertical Peak Data (1-3GHz)

Frequency MHz	Raw Pk dBuV	Polarity (V/H)	Azimuth (degrees)	Height (cm)	AF (dB/m)	Loss (dB)	Amp (dB)	Final Pk dBuV/m	Limit dBuV/m	Margin dB
1748.96	41.8	V	82.0	210.0	29.6	2.1	34.5	39.0	74.0	-35.0
2351.96	47.4	V	74.0	182.0	31.8	2.4	34.4	47.2	74.0	-26.8
2416.44	49.4	V	119.0	135.0	32.3	2.4	34.4	49.6	74.0	-24.4
2534.48	47.2	V	73.0	204.0	32.5	2.5	34.4	47.8	74.0	-26.2
2543.88	49.0	V	103.0	137.0	32.5	2.5	34.5	49.6	74.0	-24.4
Final PK = Raw PK + AF + Loss - Amp										
Margin = Final PK - Limit										

Vertical Average Data (1-3GHz)

Frequency MHz	Raw Avg dBuV	Polarity (V/H)	Azimuth (degrees)	Height (cm)	AF (dB/m)	Loss (dB)	Amp (dB)	Final Avg dBuV/m	Limit (dBuV/m)	Margin (dB)
1748.96	29.5	V	82.0	210.0	29.6	2.1	34.5	26.7	54.0	-27.3
2351.96	39.8	V	74.0	182.0	31.8	2.4	34.4	39.6	54.0	-14.4
2416.44	42.0	V	119.0	135.0	32.3	2.4	34.4	42.3	54.0	-11.7
2534.48	37.9	V	73.0	204.0	32.5	2.5	34.4	38.5	54.0	-15.5
2543.88	42.3	V	103.0	137.0	32.5	2.5	34.5	42.9	54.0	-11.1
Final Avg = Raw Avg + AF + Loss - Amp										
Margin = Final Avg - Limit										

BLE Channel 39
Horizontal Plot (1-3GHz)

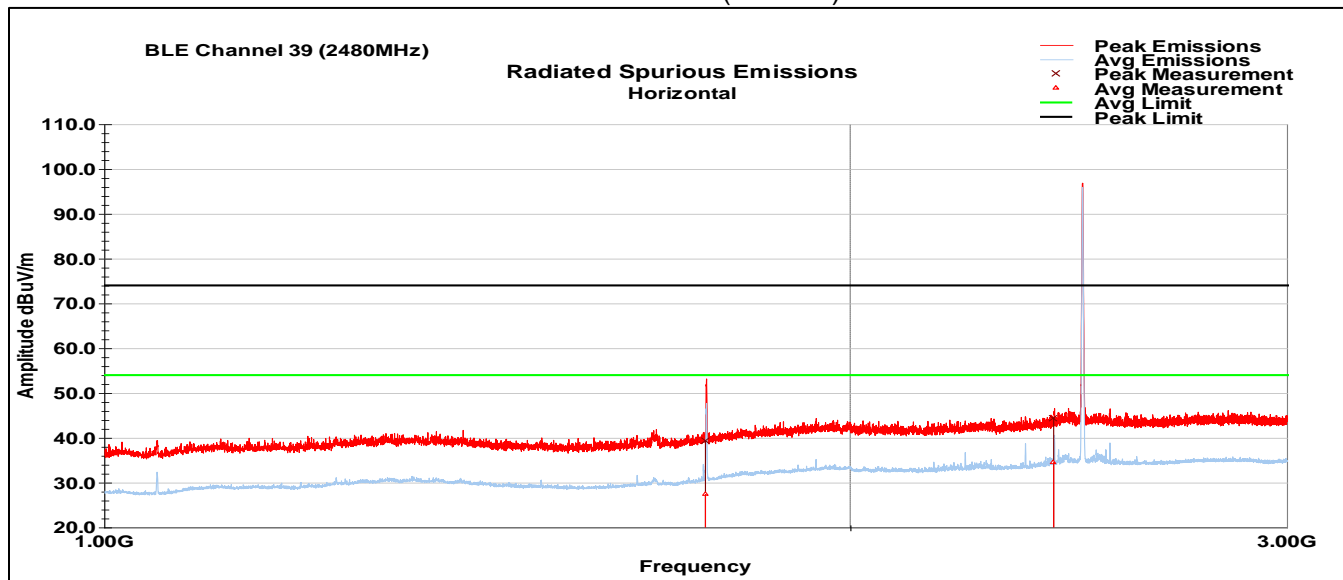

Horizontal Peak Data (1-3GHz)

Frequency MHz	Raw Pk dBuV	Polarity (V/H)	Azimuth (degrees)	Height (cm)	AF (dB/m)	Loss (dB)	Amp (dB)	Final Pk dBuV/m	Limit dBuV/m	Margin dB
1748.36	42.2	H	153.0	250.0	29.6	2.1	34.5	39.4	74.0	-34.6
2416.08	44.2	H	54.0	104.0	32.2	2.4	34.4	44.5	74.0	-29.5
Final PK = Raw PK + AF + Loss - Amp										
Margin = Final PK - Limit										

Horizontal Average Data (1-3GHz)

Frequency MHz	Raw Avg dBuV	Polarity (V/H)	Azimuth (degrees)	Height (cm)	AF (dB/m)	Loss (dB)	Amp (dB)	Avg Value dBuV/m	Limit (dBuV/m)	Margin (dB)
1748.36	30.3	H	153.0	250.0	29.6	2.1	34.5	27.4	54.0	-26.6
2416.08	34.3	H	54.0	104.0	32.2	2.4	34.4	34.6	54.0	-19.4
QP Value = Level + AF + CL - Amp										
Margin = QP Value - Limit										

BLE Channel 0
Vertical Plot (3-18GHz)

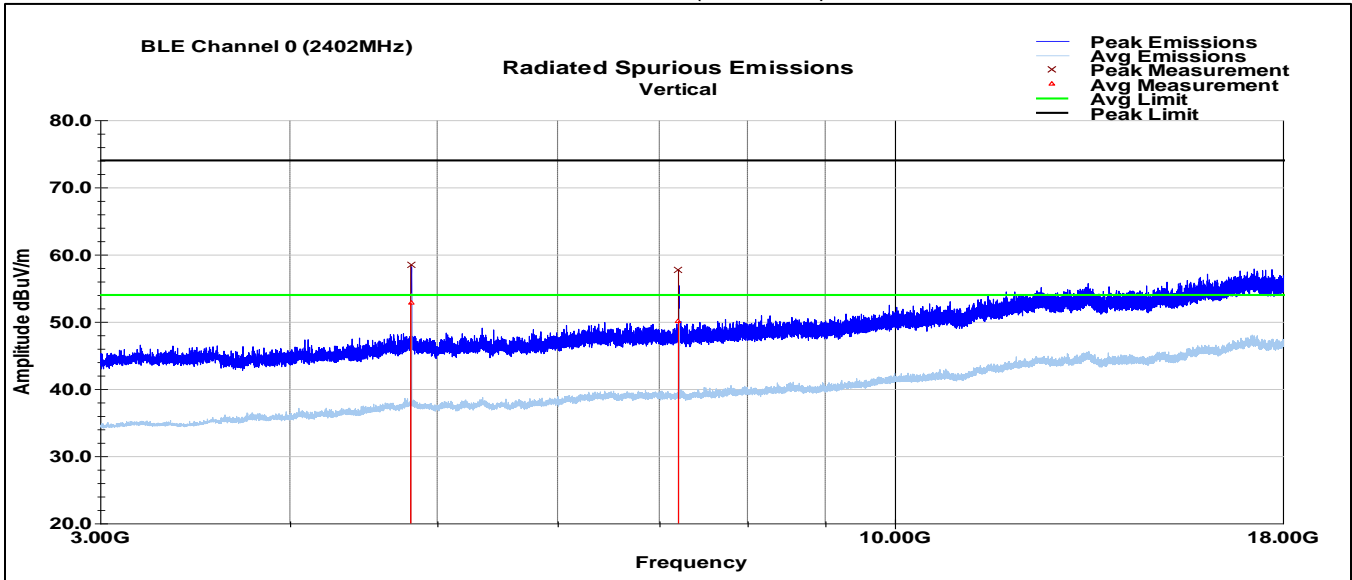

See harmonic data summary table in next section.

BLE Channel 0
Horizontal Plot (3-18GHz)

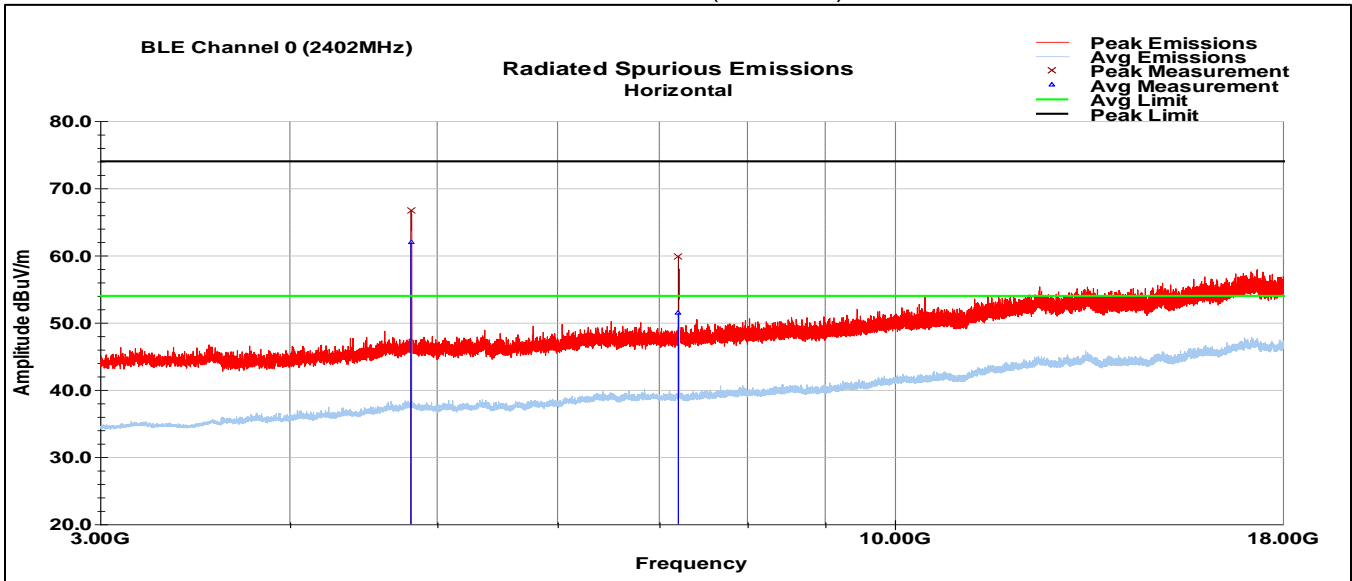

See harmonic data summary table in next section.

BLE Channel 19
Vertical Plot (3-18GHz)

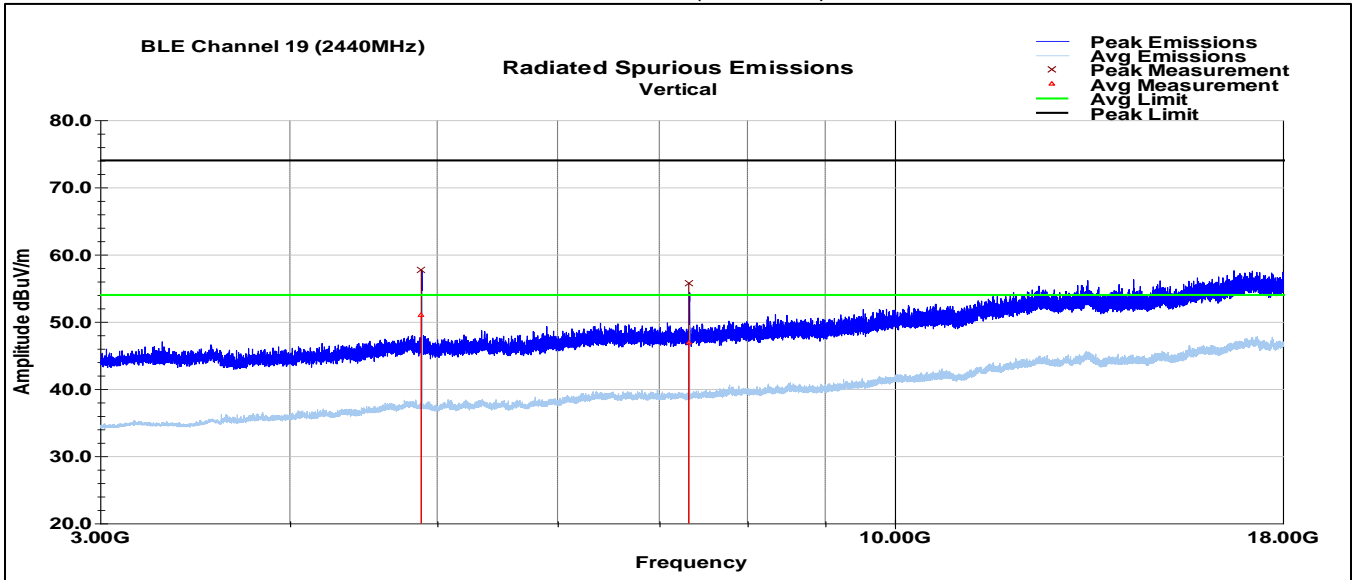

See harmonic data summary table in next section.

BLE Channel 19
Horizontal Plot (3-18GHz)

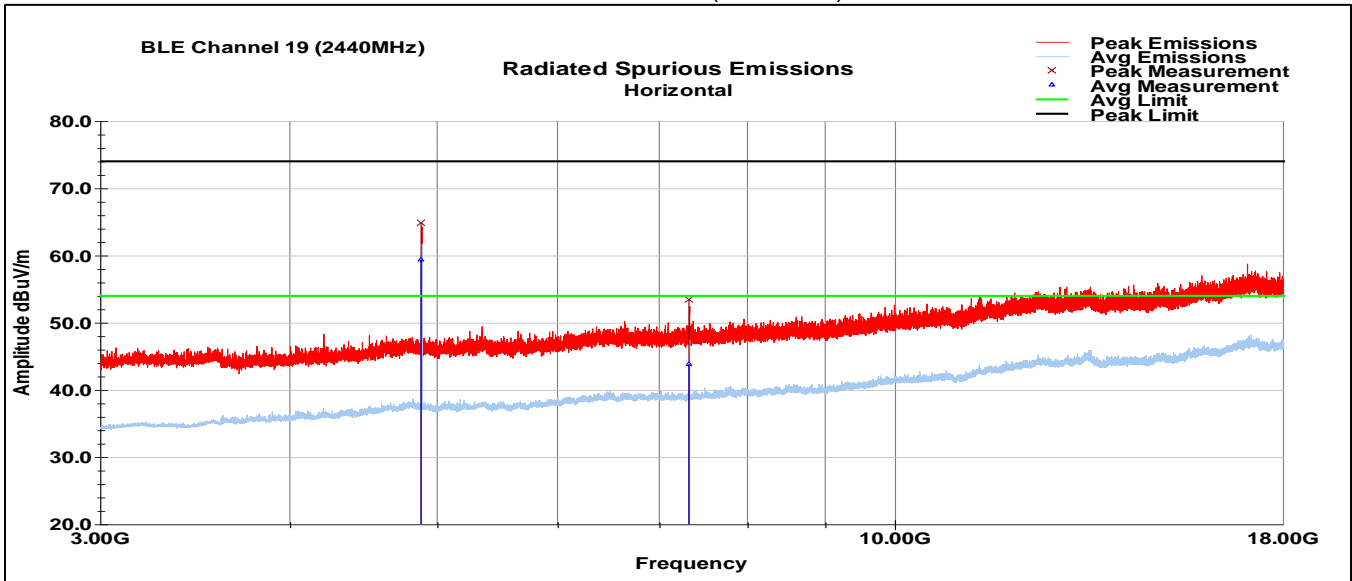

See harmonic data summary table in next section.

BLE Channel 39
Vertical Plot (3-18GHz)

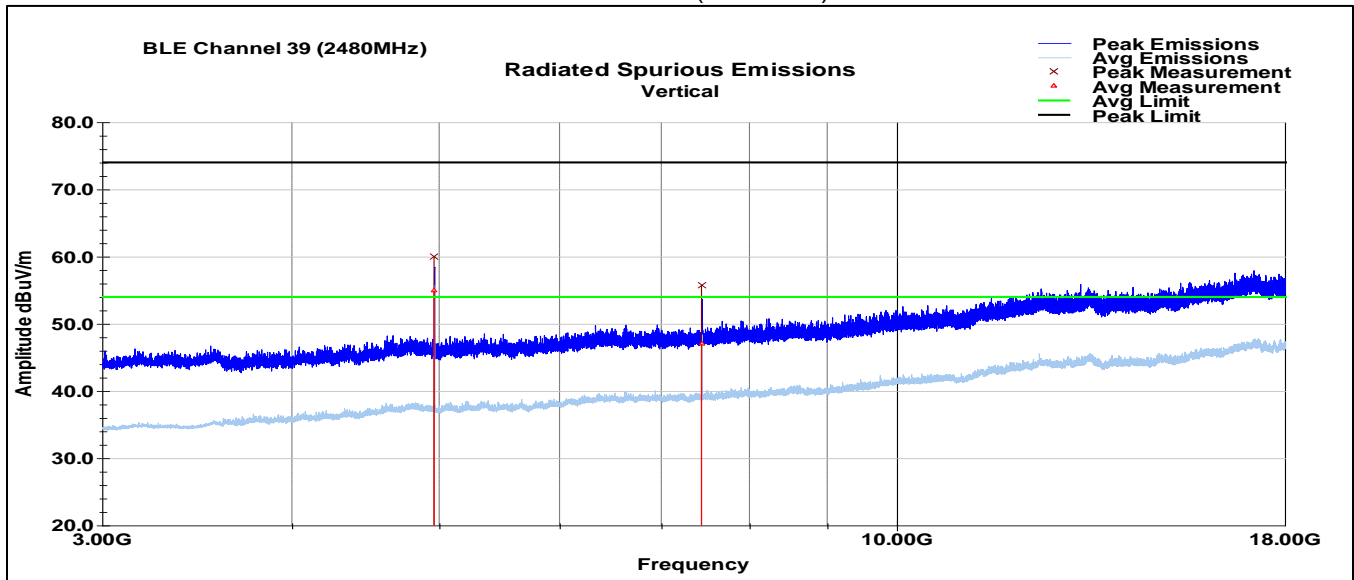

See harmonic data summary table in next section.

BLE Channel 39
Horizontal Plot (3-18GHz)

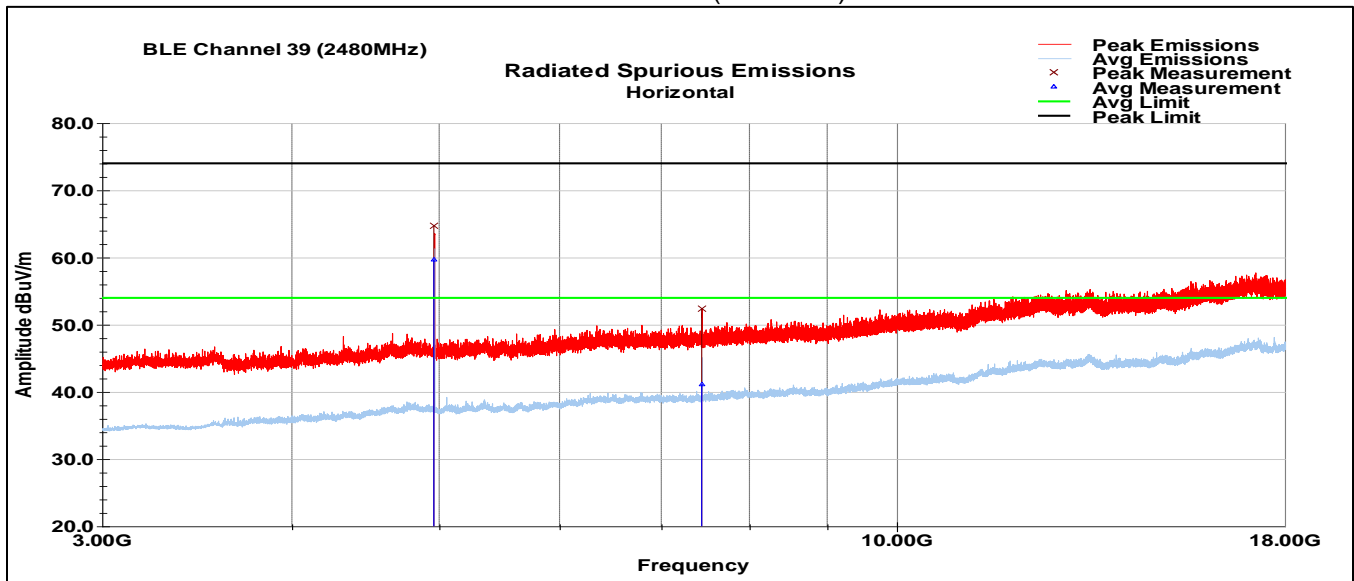

See harmonic data summary table in next section.

BLE Channel 0
Vertical Plot (18-26GHz)

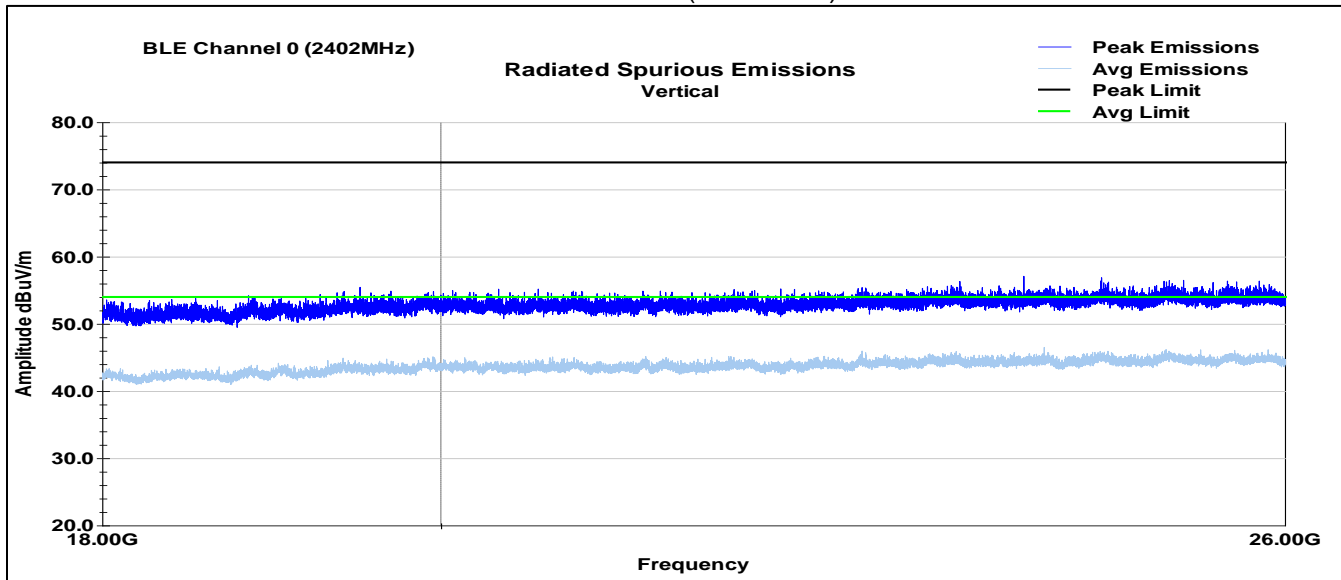

BLE Channel 0
Horizontal Plot (18-26GHz)

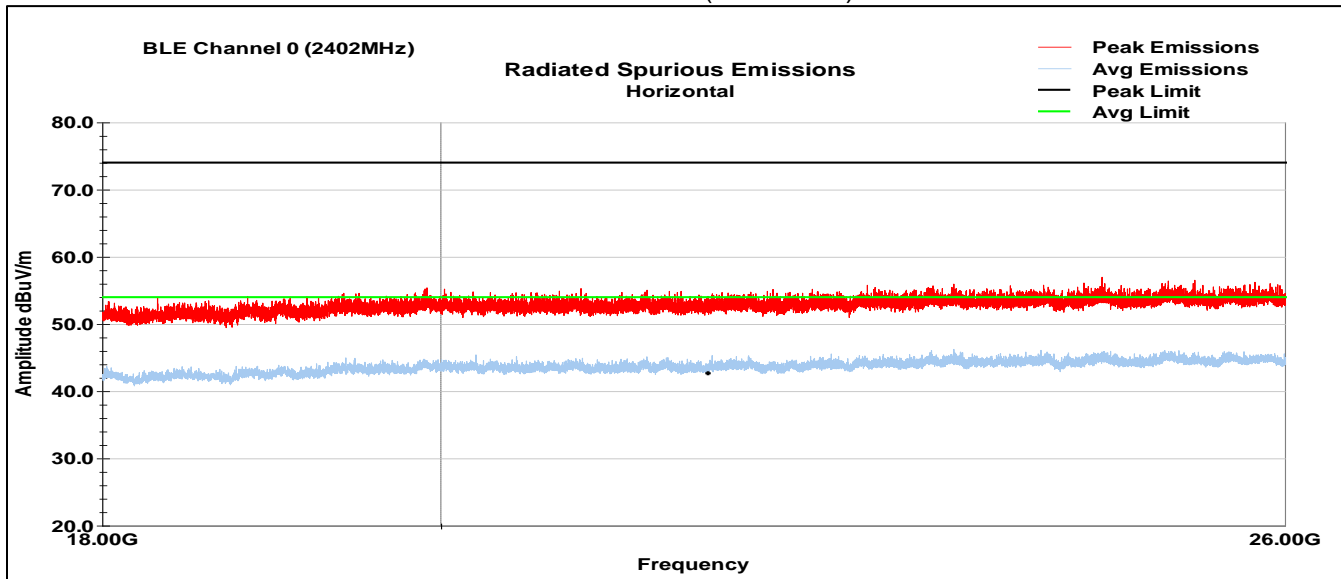

BLE Channel 19
Vertical Plot (18-26GHz)

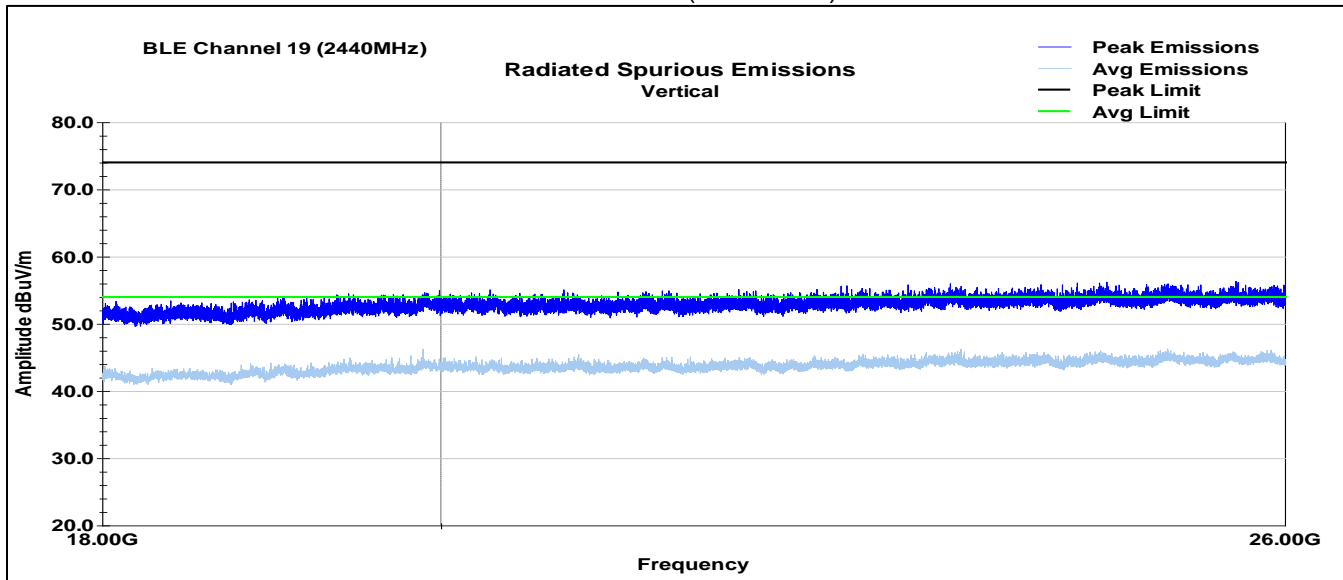

BLE Channel 19
Horizontal Plot (18-26GHz)

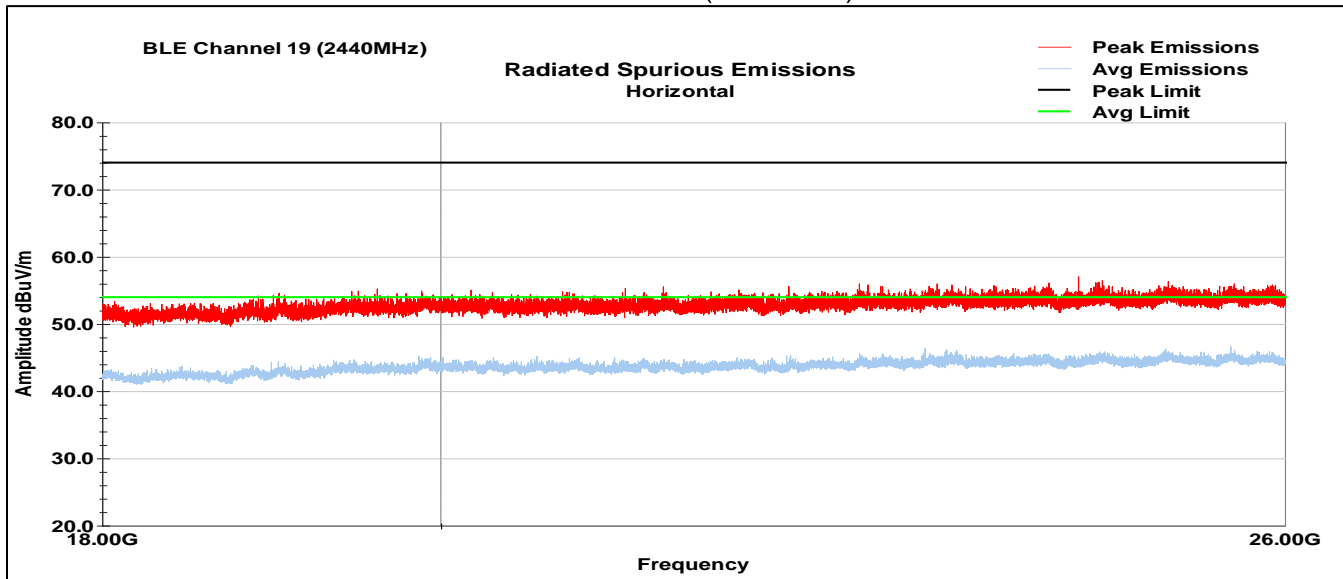

BLE Channel 39
Vertical Plot (18-26GHz)

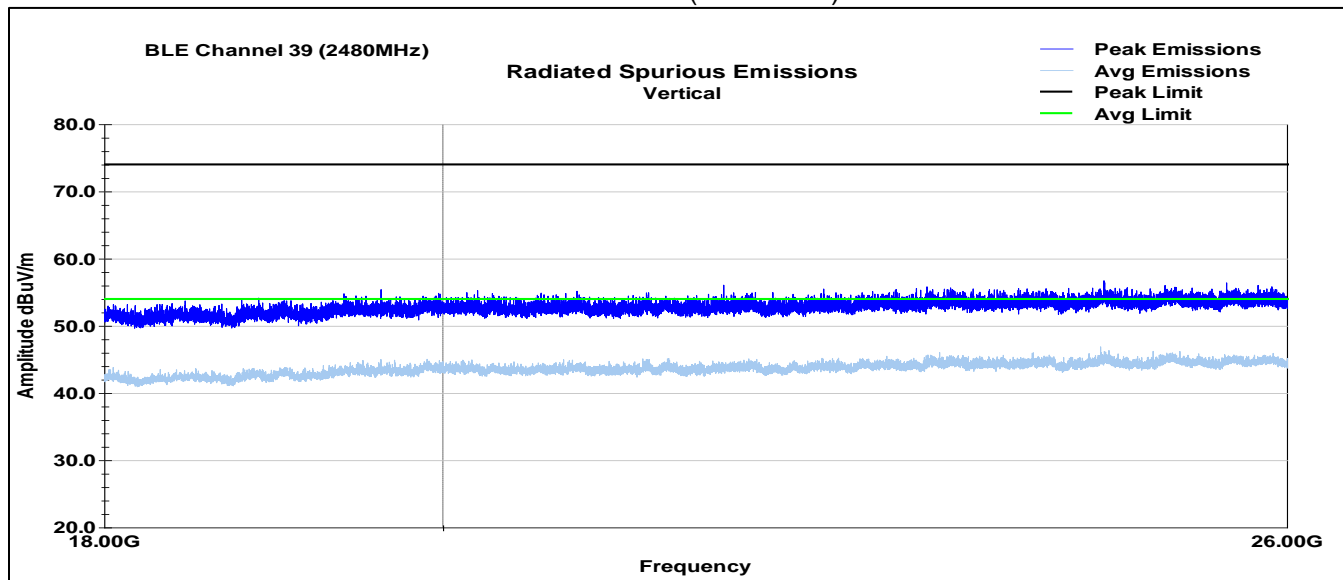

BLE Channel 39
Horizontal Plot (18-26GHz)

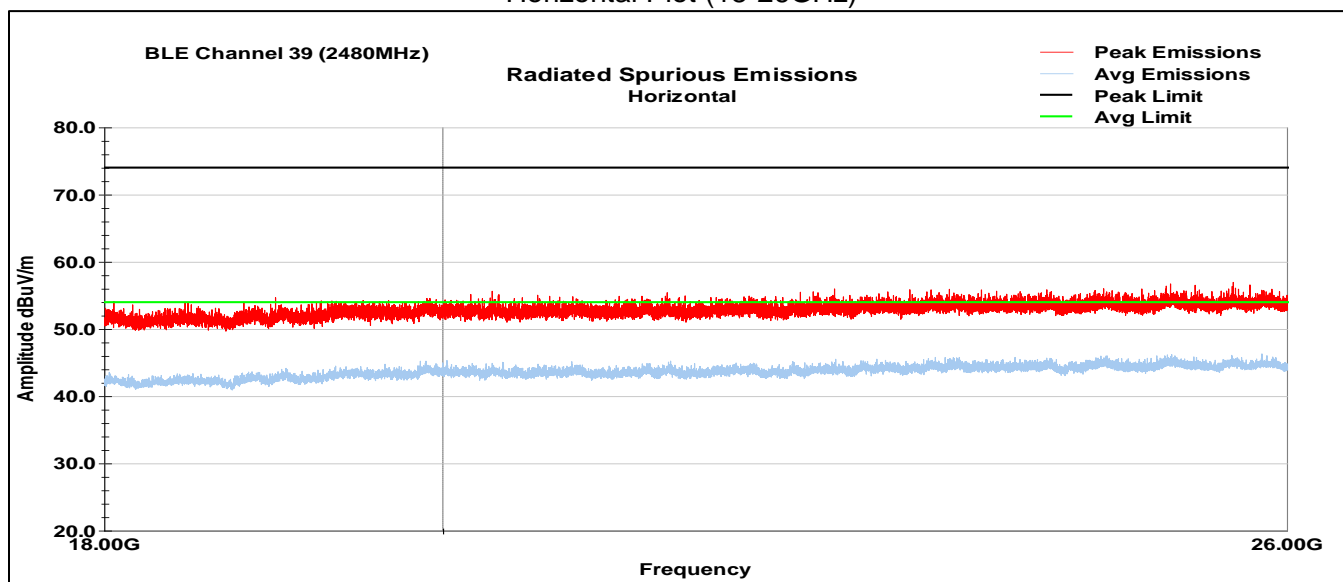

7.6 Test Data – Tabular Data

Frequency (MHz)	Avg Meas (dBuV/m)	Polarity (V/H)	DCCF (dB)	Corr Value (dBuV/m)	Limit (dBuV/m)	Margin (dB)
Channel 0 (2402MHz)						
4803.8	52.8	V	-27.89	24.95	54.0	-29.05
4804.8	62.0	H	-27.89	34.08	54.0	-19.92
7207.0	50.1	V	Not in restricted band			
7205.4	51.5	H	Not in restricted band			
Channel 19 (2440MHz)						
4880.9	51.1	V	-27.89	23.18	54.0	-30.82
4879.7	59.4	H	-27.89	31.53	54.0	-22.47
7319.6	46.9	V	-27.89	19.04	54.0	-34.97
7321.1	43.9	H	-27.89	15.96	54.0	-38.04
Channel 39 (2480MHz)						
4960.6	54.9	V	-27.89	27.04	54.0	-26.96
4959.7	59.7	H	-27.89	31.84	54.0	-22.16
7439.7	47.0	V	-27.89	19.12	54.0	-34.88
7441.6	41.2	H	-27.89	13.27	54.0	-40.74

Note: Duty Cycle Correction Factor (DCCF) is used in accordance with ANSI C63.10 clause 11.12.2.5.2 and KDB 558074 D01 15.247 Meas Guidance v05r02 Clause 11 Answer 3 measurement technique c. Tests were performed using a maximum achievable duty cycle of 95.2% for which a correction factor of 0.21dB was added to get to the levels that would have been measured had the tests been performed using 100% duty cycle. Then, based on FCC 15.35(c), a correction factor of -28.1dB was applied to the RMS average measurements to account for the 3.93% protocol limited duty cycle of normal BLE operation. KDB 558074 D01 15.247 Meas Guidance v05r02 Clause 11 Answer 3 allows for the use of this adjustment provided the following conditions are met:

- 1) the spurious emission falls in restricted bands,
- 2) the emissions are temporally related to the fundamental,
- 3) the maximum duty cycle used in determining the reduction factor is “hardwired” such that under no condition can it be changed or modified by either the device or the end user,
- 4) a documented justification for use of Section 15.35(c) including the measurements used to determine the worst-case duty cycle must be included in the test report, and
- 5) the duty cycle correction factor is the worst-case operational duty cycle based on the maximum transmission time in any 100 msec period.

These conditions are all met. Duty cycle measurements are located in Appendix A.

8 Emissions in Restricted Frequency Bands

8.1 Test Result

Test Description	Test Specification		Test Result
Emissions in Restricted Frequency Bands	15.205, 15.209	RSS-GEN S8.9, 8.10	Compliant

8.2 Test Method

Field strength measurements were performed at the restricted band edges of 2390MHz and 2483.5MHz. Measurements were made using the conducted methods defined in ANSI C63.10: 2013 clause 11.12.

Offset Calculations:

Offset calculations so that conducted measurements on the spectrum analyzer in dB μ V represent field strength measurements in dB μ V/m.

$$\text{Offset} = -20\text{Log}(D) + 104.8 - 107 + \text{CL} + \text{DC} + \text{AG}$$

$$\text{Offset}_{3\text{m}} = -11.7 + \text{CL} + \text{DC} + \text{AG}$$

D = 3m	Distance
CL = 0.89 dB	Cable Loss
DC = 0.21 dB (95.2%)	Duty Cycle Correction Factor
AG = 2 dB*	Antenna Gain

$$\text{Offset} = -8.6 \text{ dB}$$

* The actual antenna gain is 0 dBi according to the datasheet. 2 dB correction is the minimum allowed by the test method.

8.3 Test Site

SGS EMC Laboratory, Suwanee, GA

Environmental Conditions

Temperature:	23.2 °C
Relative Humidity:	48.7 %
Atmospheric Pressure:	97.1 kPa

8.4 Test Equipment

Test End Date: 4-Jan-2019

Tester: MT

Equipment	Model	Manufacturer	Asset Number	Cal Due Date
SIGNAL ANALYZER (TS8997)	FSV30	ROHDE & SCHWARZ	B085749	1-Nov-2019
RF CABLE (TS8997)	141	HUBER & SUHNER	B095585	25-Jul-2019

Note: The equipment calibration period is 1 year except for the FSV30 which is on a 2-year cycle.

8.5 Test Data – Restricted Band Edge

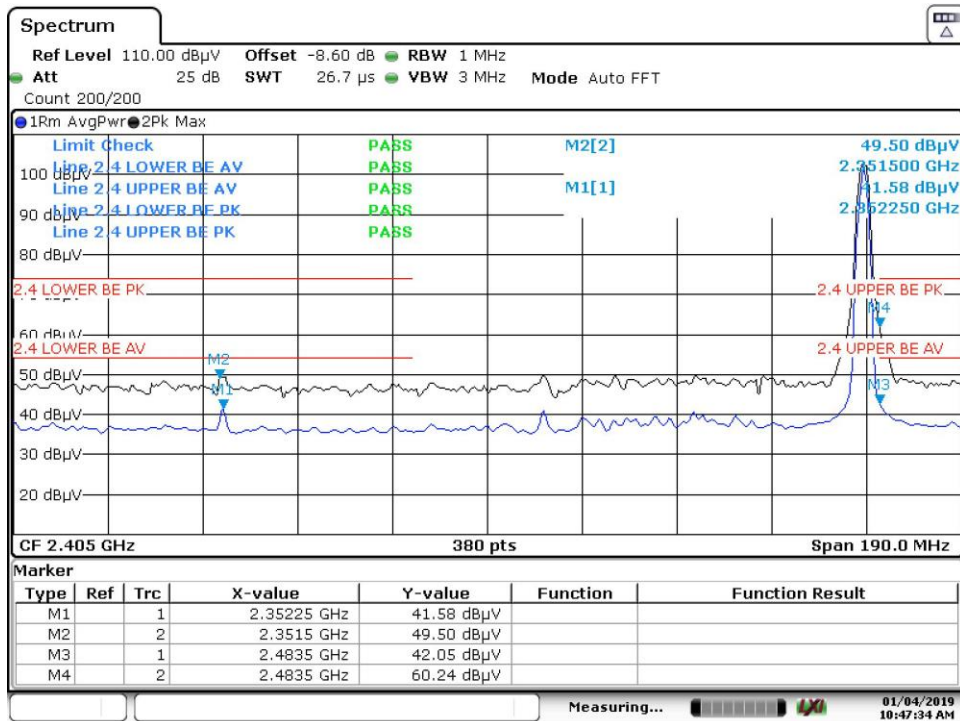
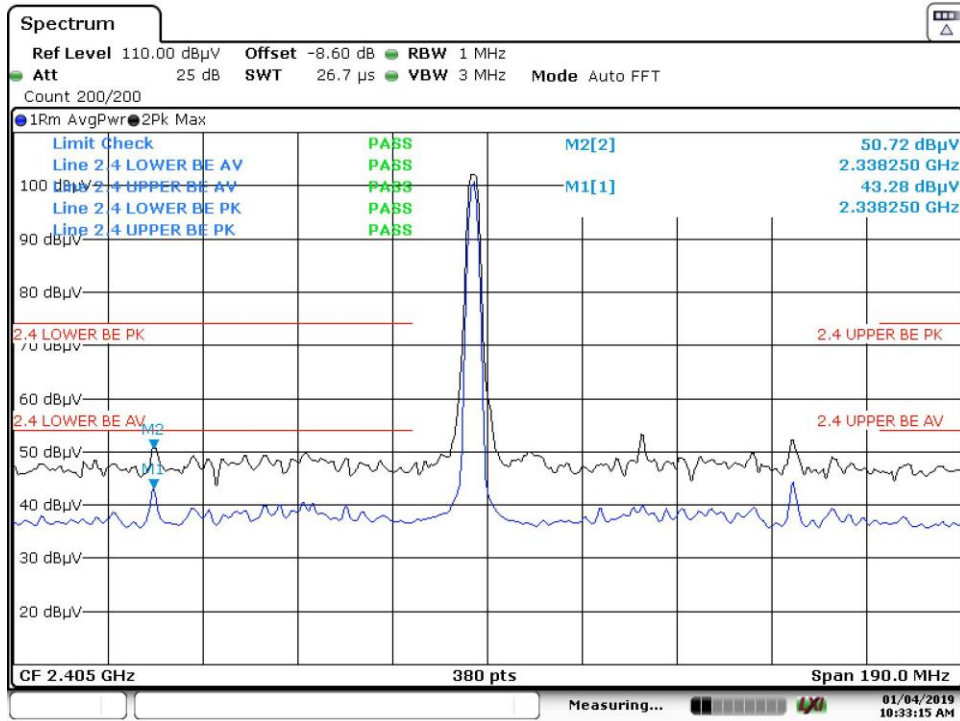

9 Revision History

Revision Level	Description of changes	Revision Date
0	Initial release	28 February 2019
1	<ul style="list-style-type: none"> - Updated sections 2.3 – 2.8 to include Dynamometer configuration with external load cell cable attached. - Updated section 7 to include radiated spurious emissions test data for Dynamometer with external load cell cable. 	11 June 2019

Appendix A: Duty-Cycle Calculations

The client states that in normal operation the Bluetooth LE radio will transmit at a maximum duty cycle equal to the combined duty cycles of the three advertising channels of the test sample they sent. Shown below is a sample measurement of the duty cycle of one of these advertising channels.

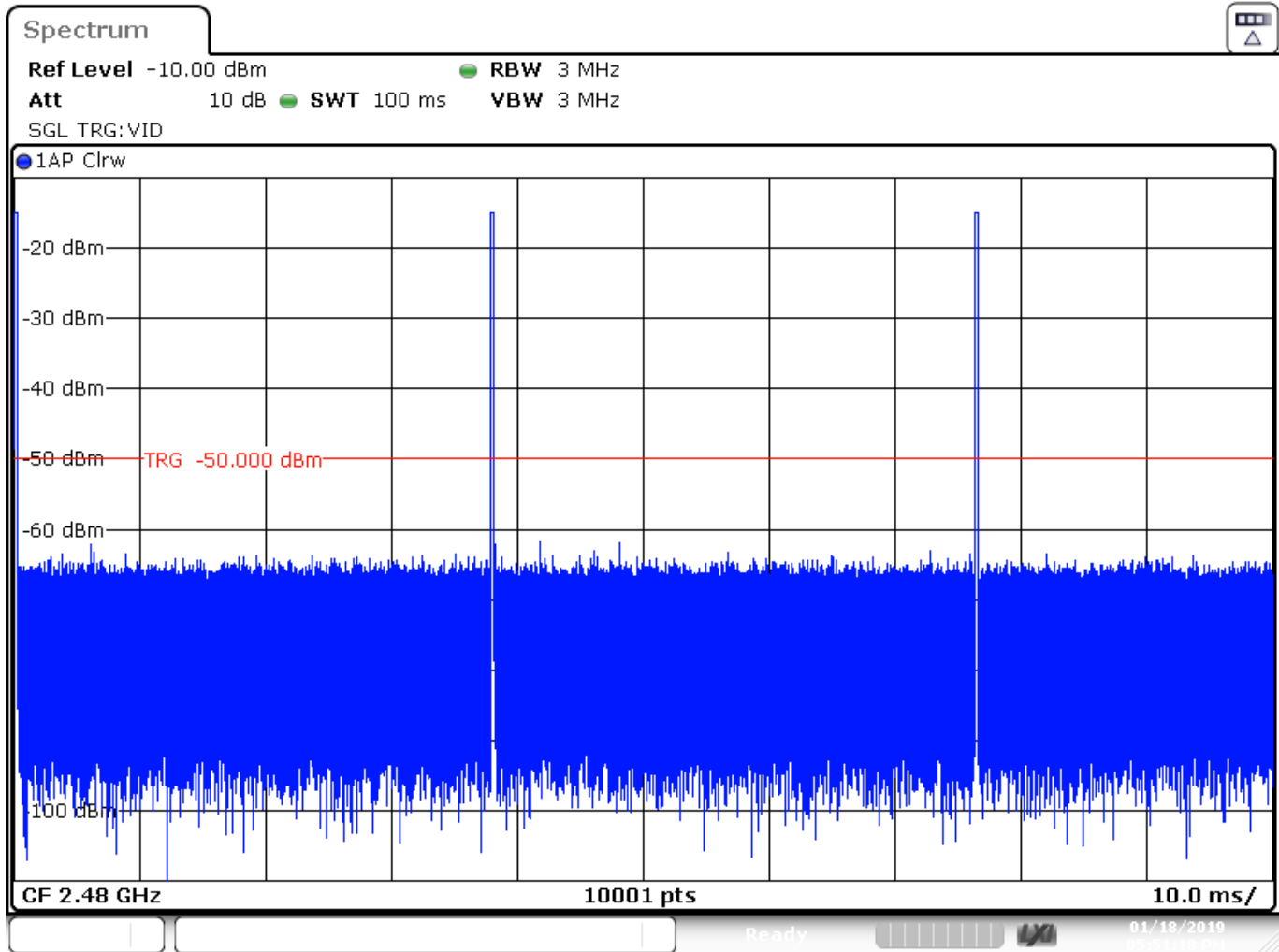

Date: 18.JAN.2019 17:51:19

Data analysis of several 100ms trace captures such as the one shown above reveals the following worst-case results: 1.31ms of total on-time and 98.69ms of off-time. This on-time is multiplied by three to get 3.93ms of total on-time in a 100ms period for the combination of the three advertising channels. This results in a total maximum duty cycle of 3.93%. So the duty cycle correction factor (DCCF) to be applied to the field strength measurements would be $20 \cdot \log_{10}(0.0393) = -28.1\text{dB}$.