

802.11n-HT20 Power Spectral Density

Channel 36 (5180MHz)

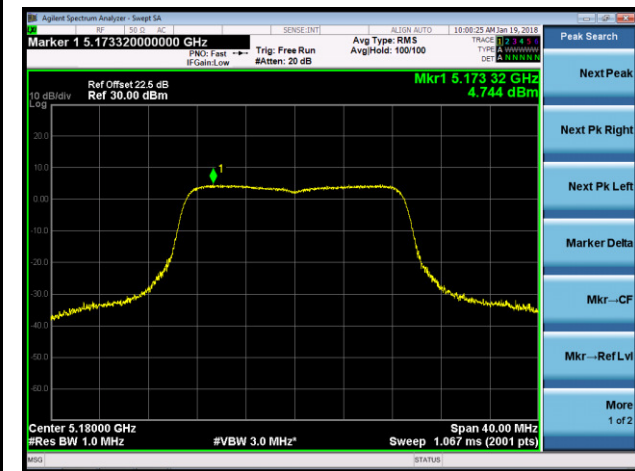

Channel 44 (5220MHz)

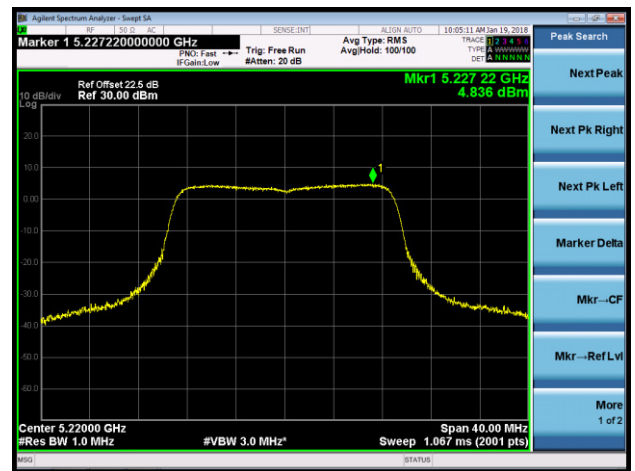

Channel 48 (5240MHz)

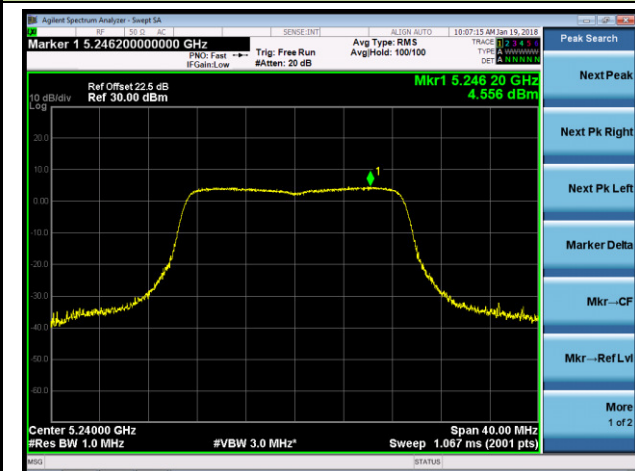

Channel 149 (5745MHz)

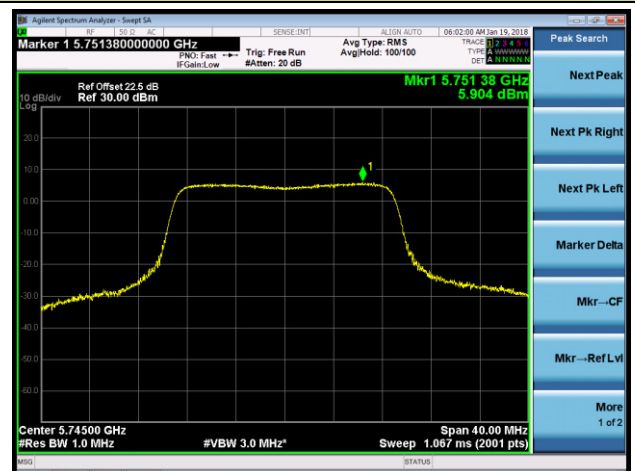

Channel 157 (5785MHz)

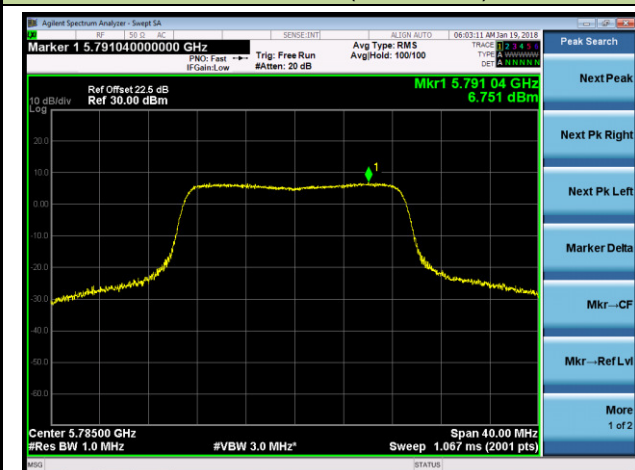

Channel 165 (5825MHz)

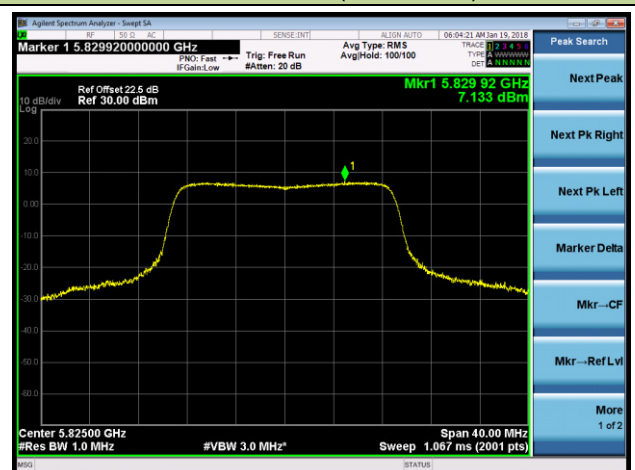

802.11n-HT40 Power Spectral Density

Channel 38 (5190MHz)

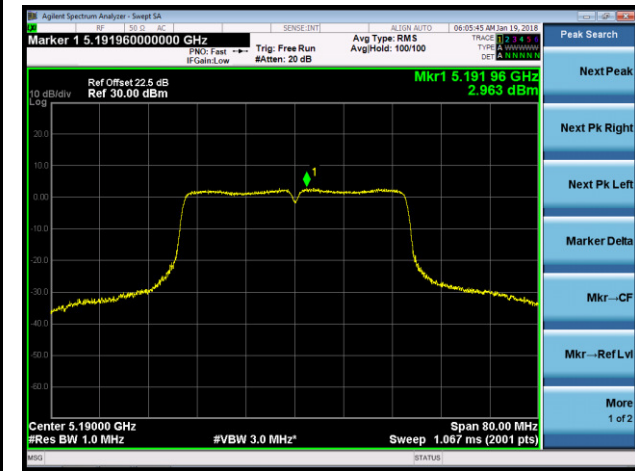

Channel 46 (5230MHz)

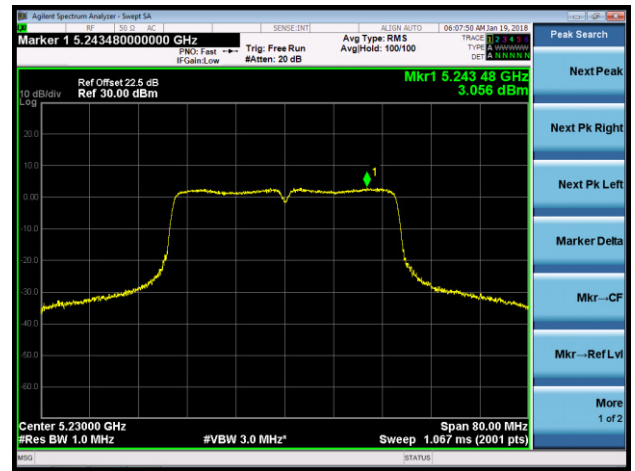

Channel 151 (5755MHz)

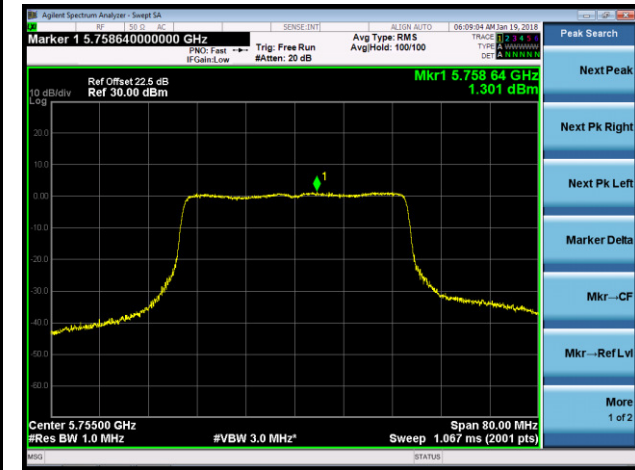

Channel 159 (5795MHz)

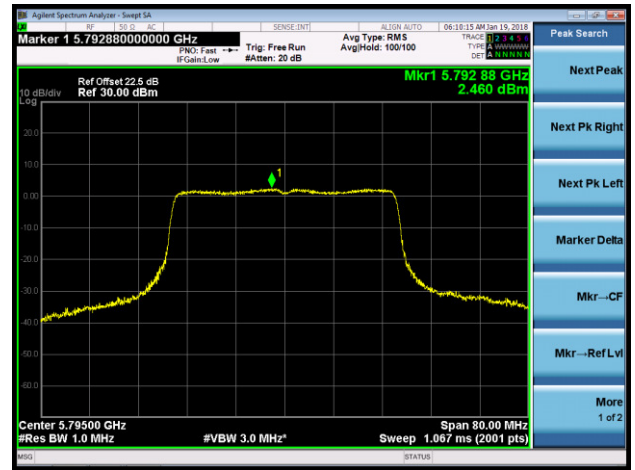

802.11ac-VHT20 Power Spectral Density

Channel 36 (5180MHz)

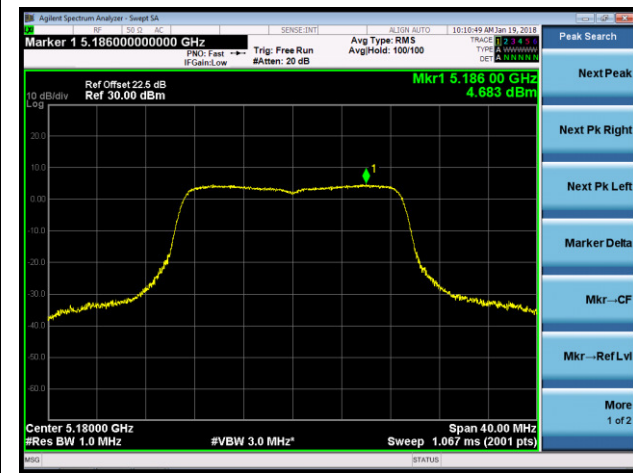

Channel 44 (5220MHz)

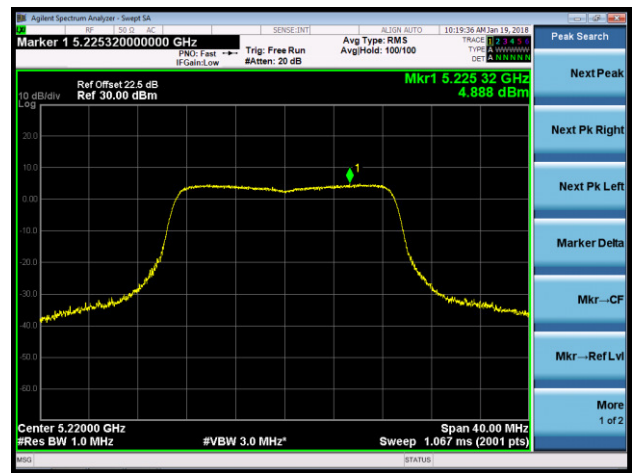

Channel 48 (5240MHz)

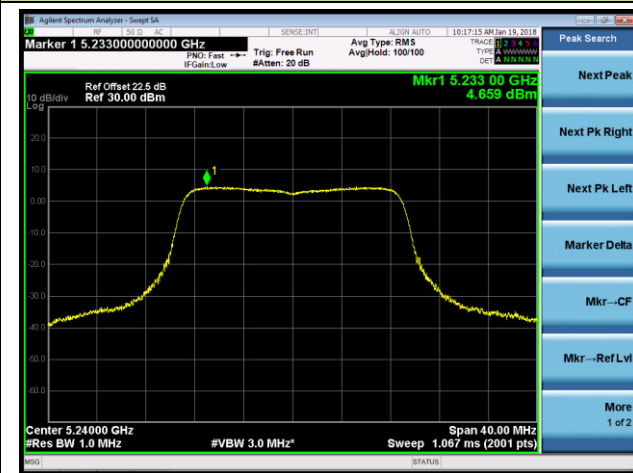

Channel 149 (5745MHz)

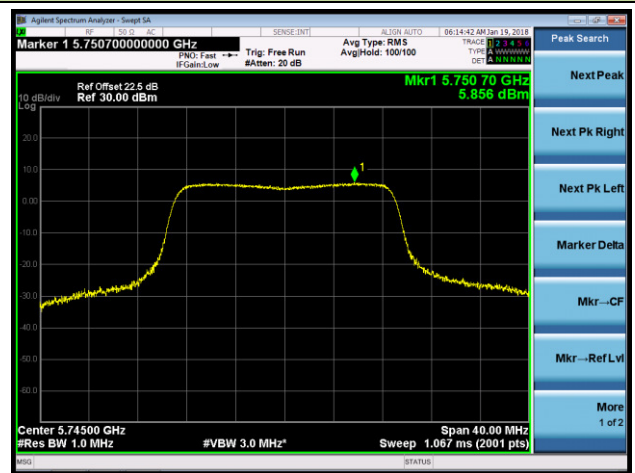

Channel 157 (5785MHz)

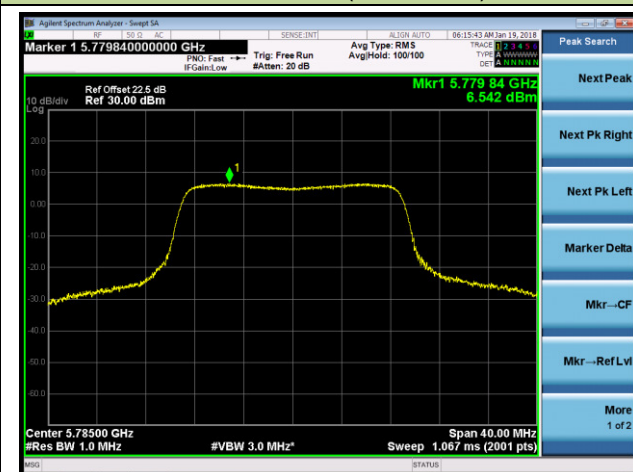

Channel 165 (5825MHz)



802.11ac-VHT40 Power Spectral Density

Channel 38 (5190MHz)

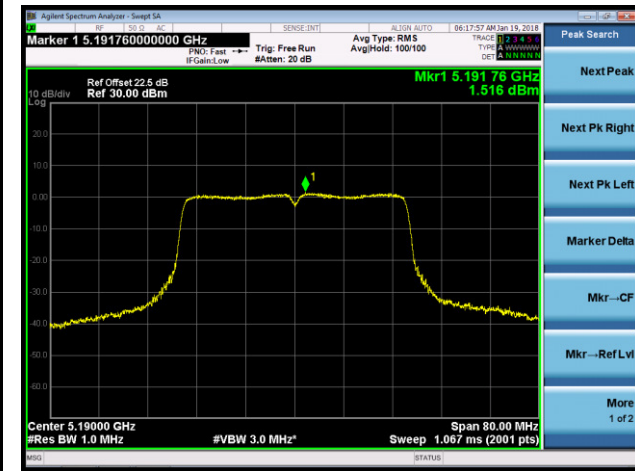

Channel 46 (5230MHz)

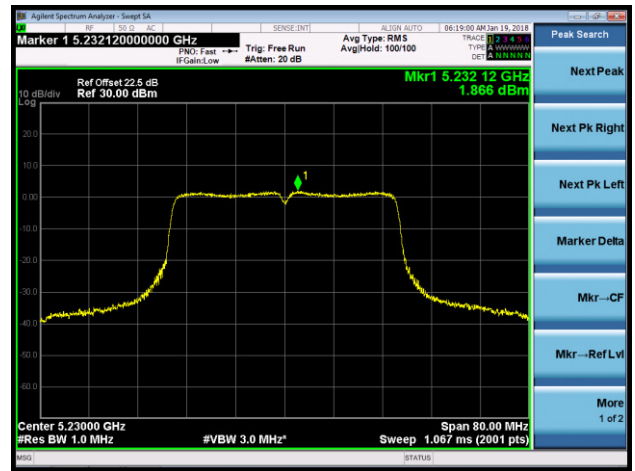

Channel 151 (5755MHz)

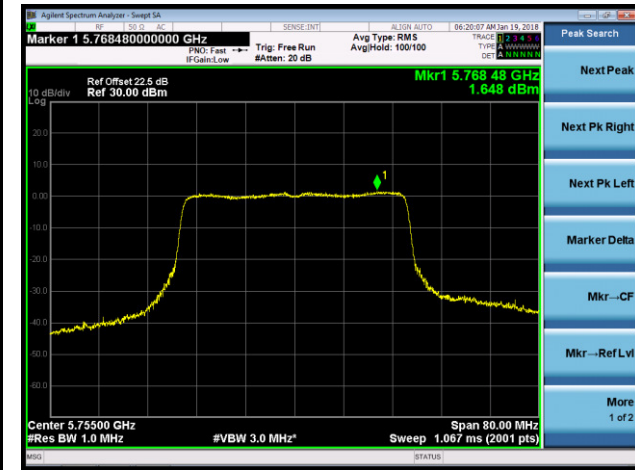

Channel 159 (5795MHz)

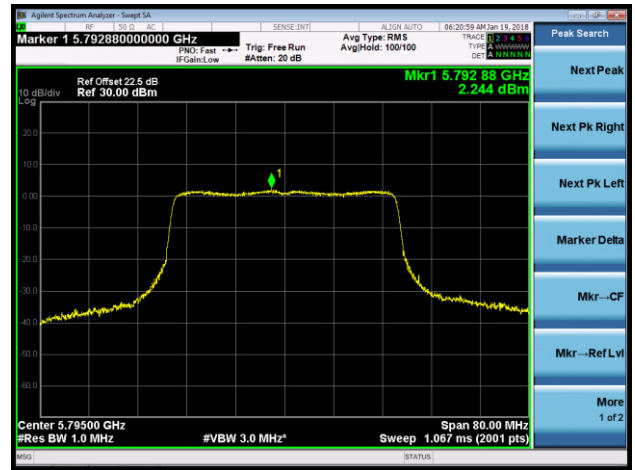

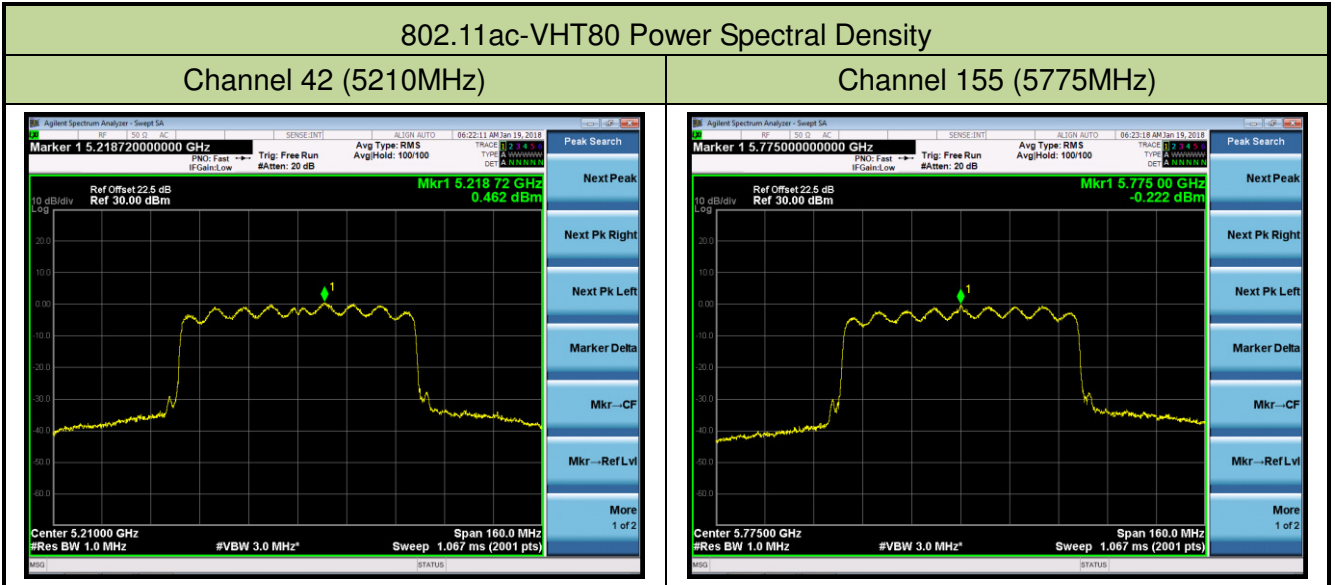

## 7.6. Frequency Stability Measurement

### 7.6.1. Test Limit

The transmitter center frequency tolerance shall be  $\pm 20$  ppm maximum for the 5GHz band (IEEE 802.11 specification).

### 7.6.2. Test Procedure Used

#### Frequency Stability Under Temperature Variations:

The equipment under test was connected to an external AC or DC power supply and input rated voltage. RF output was connected to a frequency counter or spectrum analyzer via feed through attenuators. The EUT was placed inside the temperature chamber. Set the spectrum analyzer RBW low enough to obtain the desired frequency resolution and measure EUT 20°C operating frequency as reference frequency. Turn EUT off and set the chamber temperature to highest. After the temperature stabilized for approximately 30 minutes recorded the frequency. Repeat step measure with 10°C decreased per stage until the lowest temperature reached.

#### Frequency Stability Under Voltage Variations:

Set chamber temperature to 20°C. Use a variable AC power supply / DC power source to power the EUT and set the voltage to rated voltage. Set the spectrum analyzer RBW low enough to obtain the desired frequency resolution and recorded the frequency.

Reduce the input voltage to specify extreme voltage variation ( $\pm 15\%$ ) and endpoint, record the maximum frequency change.

### 7.6.3. Test Setup

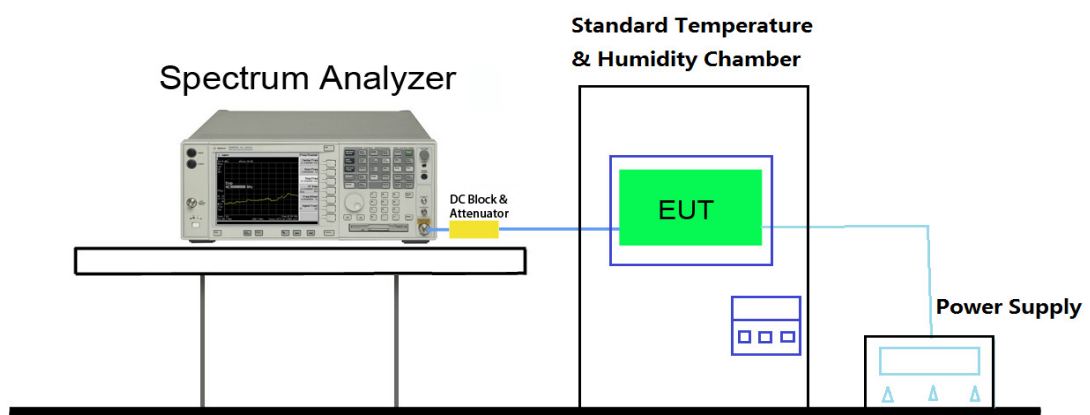

#### 7.6.4. Test Result

Product	Speed Dome Camera (1080P WiFi PTZ)	Temperature	-30 ~ 50°C
Test Engineer	Ben Zhu	Relative Humidity	46 ~ 66%
Test Site	TR3	Test Date	2018/01/19

Voltage (%)	Power (VAC)	Temp (°C)	Frequency Tolerance (ppm)			
			0 minutes	2 minutes	5 minutes	10 minutes
100%	120	- 30	4.76	5.74	5.44	6.48
		- 20	4.63	4.78	5.37	4.41
		- 10	6.53	7.03	6.06	6
		0	4.6	5.55	4.07	6.85
		+ 10	7.02	6.8	6.79	5.45
		+ 20 (Ref)	2.05	2.25	4.24	3.49
		+ 30	1.45	0.49	1.5	-0.54
		+ 40	-0.47	-0.36	-1.01	0.85
		+ 50	-1.33	-1.04	-1.55	-2.31
115%	138	+ 20	1.51	1.08	0.41	-1.69
85%	102	+ 20	-1.41	0.45	-1.95	-2.22

Note: Frequency Tolerance (ppm) =  $\frac{\{[\text{Measured Frequency (Hz)} - \text{Declared Frequency (Hz)}] / \text{Declared Frequency (Hz)}\} * 10^6}$ .

## 7.7. Radiated Spurious Emission Measurement

### 7.7.1. Test Limit

All out of band emissions appearing in a restricted band as specified in Section 15.205 of the Title 47 CFR must not exceed the limits shown in Table per Section 15.209.

All out of band emissions appearing in a restricted band as specified in Section 8.10 of the RSS-Gen Issue 4 must not exceed the limits shown in Table per Section 8.9.

FCC Part 15 Subpart C Paragraph 15.209 & RSS-Gen Issue4 Section 8.9		
Frequency [MHz]	Field Strength [uV/m]	Measured Distance [Meters]
0.009 ~ 0.490	2400/F (kHz)	300
0.490 ~ 1.705	24000/F (kHz)	30
1.705 ~ 30	30	30
30 ~ 88	100	3
88 ~ 216	150	3
216 ~ 960	200	3
Above 960	500	3

### 7.7.2. Test Procedure Used

ANSI C63.10 Section 6.3 (General Requirements)

ANSI C63.10 Section 6.4 (Standard test method below 30MHz)

ANSI C63.10 Section 6.5 (Standard test method above 30MHz to 1GHz)

ANSI C63.10 Section 6.6 (Standard test method above 1GHz)



### **7.7.3. Test Setting**

#### **Quasi-Peak & Average Measurements below 30MHz**

1. Analyzer center frequency was set to the frequency of the radiated spurious emission of interest
2. Span was set greater than 1MHz
3. RBW = 200Hz for 9kHz to 150kHz frequency; RBW = 9kHz for 0.15MHz to 30MHz frequency
4. Detector = CISPR quasi-peak or power average (Average)
5. Sweep time = auto couple
6. Trace was allowed to stabilize

#### **Quasi-Peak Measurements below 1GHz**

1. Analyzer center frequency was set to the frequency of the radiated spurious emission of interest
2. Span was set greater than 1MHz
3. RBW = 120 kHz
4. Detector = CISPR quasi-peak
5. Sweep time = auto couple
6. Trace was allowed to stabilize

#### **Peak Measurements above 1GHz**

1. Analyzer center frequency was set to the frequency of the radiated spurious emission of interest
2. RBW = 1MHz
3. VBW = 3MHz
4. Detector = peak
5. Sweep time = auto couple
6. Trace mode = max hold
7. Trace was allowed to stabilize

#### **Average Measurements above 1GHz (Method AD)**

1. Analyzer center frequency was set to the frequency of the radiated spurious emission of interest
2. RBW = 1MHz
3. VBW = 3MHz
4. Detector = power average (Average)
5. Number of measurement points = 1001 (Number of points must be  $> 2 \times \text{span}/\text{RBW}$ )
6. Sweep time = auto
7. Trace was averaged over at 100 sweeps

### 7.7.4. Test Setup

#### 9kHz ~ 30MHz Test Setup:

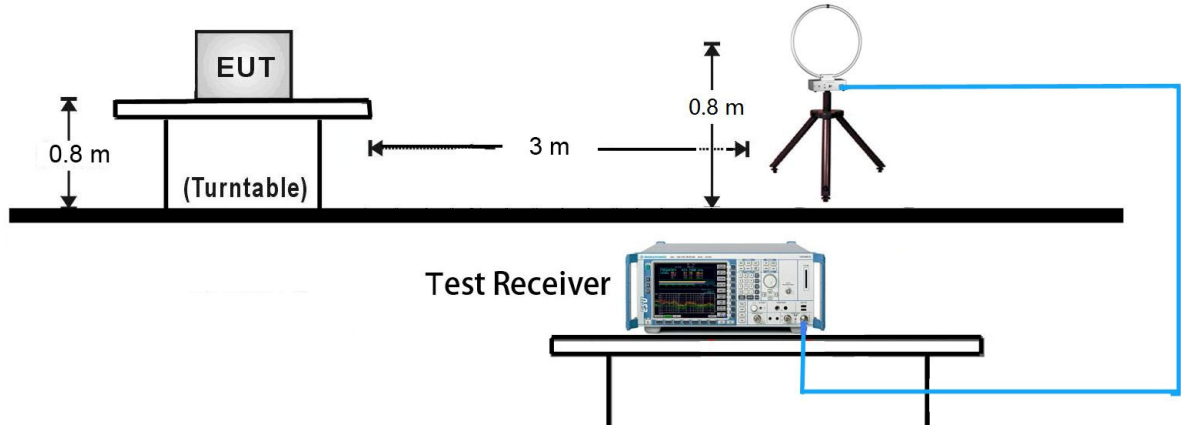

#### 30MHz ~ 1GHz Test Setup:

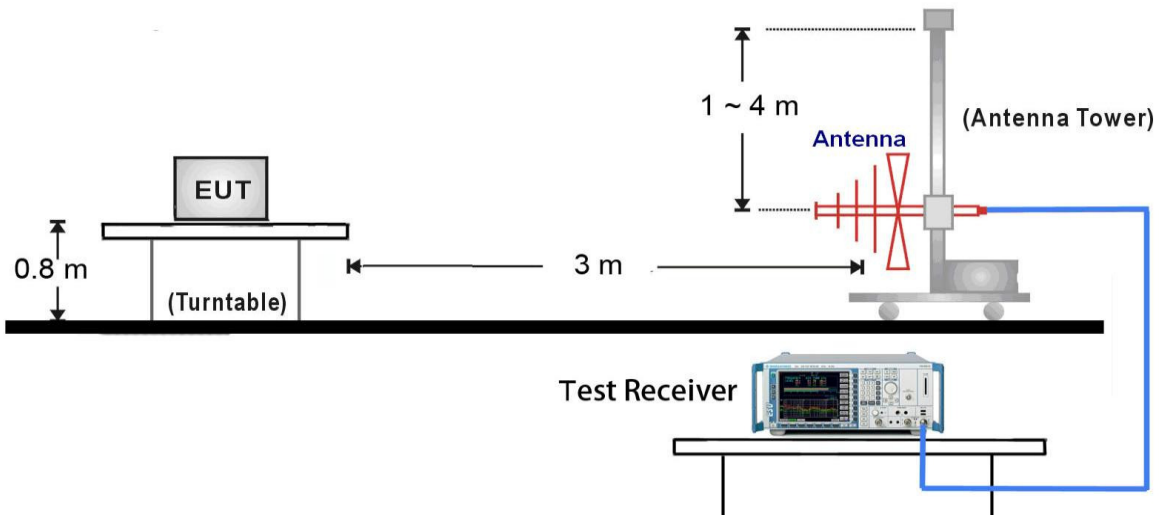

#### 1GHz ~ 40GHz Test Setup:

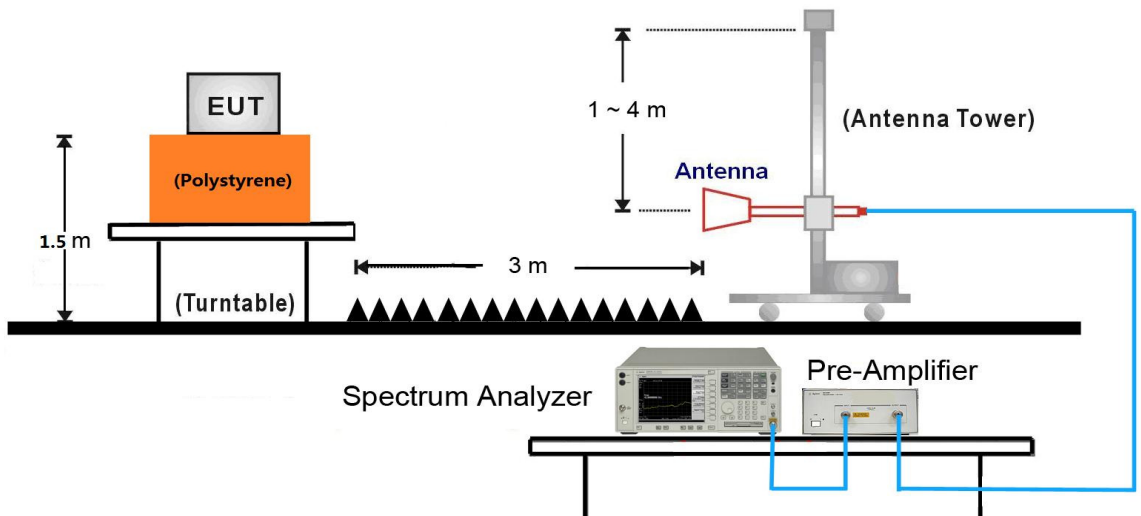

**7.7.5. Test Result**

Product	Speed Dome Camera (1080P WiFi PTZ)	Temperature	22°C
Test Engineer	Snake Ni	Relative Humidity	51%
Test Site	AC2	Test Date	2018/01/23
Test Mode:	802.11a	Test Channel:	36
Remark:	1. Average measurement was not performed if peak level lower than average limit. 2. Other frequency was 20dB below limit line within 1-18GHz, there is not show in the report.		

Mark	Frequency (MHz)	Reading Level (dBμV)	Factor (dB)	Measure Level (dBμV/m)	Limit (dBμV/m)	Margin (dB)	Detector	Polarization
	7477.0	33.3	14.0	47.3	74.0	-26.7	Peak	Horizontal
*	10350.0	32.1	18.5	50.6	74.0	-23.4	Peak	Horizontal
*	13605.5	29.4	23.1	52.5	74.0	-21.5	Peak	Horizontal
	15713.5	32.4	21.3	53.7	74.0	-20.3	Peak	Horizontal
	7341.0	33.8	13.9	47.7	74.0	-26.3	Peak	Vertical
*	10520.0	32.1	18.9	51.0	74.0	-23.0	Peak	Vertical
*	13622.5	30.0	23.2	53.2	74.0	-20.8	Peak	Vertical
	15730.5	32.4	21.4	53.8	74.0	-20.2	Peak	Vertical

Note 1: "\*" is not in restricted band, its limit is -27dBm/MHz. At a distance of 3 meters, the field strength limit in dBμV/m can be determined by adding a "conversion" factor of 95.2dB to the EIRP limit of -27dBm/MHz to obtain the limit for out of band spurious emissions.

Note 2: Measure Level (dBμV/m) = Reading Level (dBμV) + Factor (dB)

Factor (dB) = Cable Loss (dB) + Antenna Factor (dB/m) - Pre\_Amplifier Gain (dB)

Product	Speed Dome Camera (1080P WiFi PTZ)	Temperature	22°C
Test Engineer	Snake Ni	Relative Humidity	51%
Test Site	AC2	Test Date	2018/01/23
Test Mode:	802.11a	Test Channel:	44
Remark:	1. Average measurement was not performed if peak level lower than average limit. 2. Other frequency was 20dB below limit line within 1-18GHz, there is not show in the report.		

Mark	Frequency (MHz)	Reading Level (dBμV)	Factor (dB)	Measure Level (dBμV/m)	Limit (dBμV/m)	Margin (dB)	Detector	Polarization
	7485.5	33.4	14.0	47.4	74.0	-26.6	Peak	Horizontal
*	10282.0	32.5	18.3	50.8	74.0	-23.2	Peak	Horizontal
*	13767.0	29.5	23.0	52.5	74.0	-21.5	Peak	Horizontal
	15739.0	32.3	21.5	53.8	74.0	-20.2	Peak	Horizontal
	7375.0	38.4	13.9	52.3	74.0	-21.7	Peak	Vertical
	7406.9	27.0	13.9	40.9	54.0	-13.1	Average	Vertical
*	10537.0	32.5	18.9	51.4	74.0	-22.6	Peak	Vertical
*	13792.5	29.7	23.3	53.0	74.0	-21.0	Peak	Vertical
	15679.5	32.5	21.1	53.6	74.0	-20.4	Peak	Vertical

Note 1: "\*" is not in restricted band, its limit is -27dBm/MHz. At a distance of 3 meters, the field strength limit in dBμV/m can be determined by adding a "conversion" factor of 95.2dB to the EIRP limit of -27dBm/MHz to obtain the limit for out of band spurious emissions.

Note 2: Measure Level (dBμV/m) = Reading Level (dBμV) + Factor (dB)

Factor (dB) = Cable Loss (dB) + Antenna Factor (dB/m) - Pre\_Amplifier Gain (dB)

Product	Speed Dome Camera (1080P WiFi PTZ)	Temperature	22°C
Test Engineer	Snake Ni	Relative Humidity	51%
Test Site	AC2	Test Date	2018/01/23
Test Mode:	802.11a	Test Channel:	48
Remark:	1. Average measurement was not performed if peak level lower than average limit. 2. Other frequency was 20dB below limit line within 1-18GHz, there is not show in the report.		

Mark	Frequency (MHz)	Reading Level (dBμV)	Factor (dB)	Measure Level (dBμV/m)	Limit (dBμV/m)	Margin (dB)	Detector	Polarization
	7434.5	36.4	14.3	50.7	74.0	-23.3	Peak	Horizontal
*	10477.5	32.2	18.8	51.0	74.0	-23.0	Peak	Horizontal
*	13673.5	29.7	22.7	52.4	74.0	-21.6	Peak	Horizontal
	15883.5	32.0	21.6	53.6	74.0	-20.4	Peak	Horizontal
	7434.5	38.4	14.3	52.7	74.0	-21.3	Peak	Vertical
*	10494.5	31.6	18.9	50.5	74.0	-23.5	Peak	Vertical
*	13699.0	29.5	23.0	52.5	74.0	-21.5	Peak	Vertical
	15866.5	32.2	21.7	53.9	74.0	-20.1	Peak	Vertical

Note 1: "\*" is not in restricted band, its limit is -27dBm/MHz. At a distance of 3 meters, the field strength limit in dBμV/m can be determined by adding a "conversion" factor of 95.2dB to the EIRP limit of -27dBm/MHz to obtain the limit for out of band spurious emissions.

Note 2: Measure Level (dBμV/m) = Reading Level (dBμV) + Factor (dB)

Factor (dB) = Cable Loss (dB) + Antenna Factor (dB/m) - Pre\_Amplifier Gain (dB)

Product	Speed Dome Camera (1080P WiFi PTZ)	Temperature	22°C
Test Engineer	Snake Ni	Relative Humidity	51%
Test Site	AC2	Test Date	2018/01/23
Test Mode:	802.11a	Test Channel:	149
Remark:	1. Average measurement was not performed if peak level lower than average limit. 2. Other frequency was 20dB below limit line within 1-18GHz, there is not show in the report.		

Mark	Frequency (MHz)	Reading Level (dBμV)	Factor (dB)	Measure Level (dBμV/m)	Limit (dBμV/m)	Margin (dB)	Detector	Polarization
	7562.0	35.1	14.1	49.2	74.0	-24.8	Peak	Horizontal
	11497.5	33.3	20.6	53.9	74.0	-20.1	Peak	Horizontal
*	13563.0	29.6	23.0	52.6	74.0	-21.4	Peak	Horizontal
*	16308.5	31.4	22.3	53.7	74.0	-20.3	Peak	Horizontal
	7468.5	36.7	14.1	50.8	74.0	-23.2	Peak	Vertical
	11540.0	31.5	20.9	52.4	74.0	-21.6	Peak	Vertical
*	13860.5	29.1	23.7	52.8	74.0	-21.2	Peak	Vertical
*	16444.5	31.0	22.4	53.4	74.0	-20.6	Peak	Vertical

Note 1: "\*" is not in restricted band, its limit is -27dBm/MHz. At a distance of 3 meters, the field strength limit in dBμV/m can be determined by adding a "conversion" factor of 95.2dB to the EIRP limit of -27dBm/MHz to obtain the limit for out of band spurious emissions.

Note 2: Measure Level (dBμV/m) = Reading Level (dBμV) + Factor (dB)

Factor (dB) = Cable Loss (dB) + Antenna Factor (dB/m) – Pre\_Amplifier Gain (dB)

Product	Speed Dome Camera (1080P WiFi PTZ)	Temperature	22°C
Test Engineer	Snake Ni	Relative Humidity	51%
Test Site	AC2	Test Date	2018/01/23
Test Mode:	802.11a	Test Channel:	157
Remark:	1. Average measurement was not performed if peak level lower than average limit. 2. Other frequency was 20dB below limit line within 1-18GHz, there is not show in the report.		

Mark	Frequency (MHz)	Reading Level (dBμV)	Factor (dB)	Measure Level (dBμV/m)	Limit (dBμV/m)	Margin (dB)	Detector	Polarization
	7451.5	35.6	14.3	49.9	74.0	-24.1	Peak	Horizontal
	11565.5	35.3	20.8	56.1	74.0	-17.9	Peak	Horizontal
	11569.2	20.2	20.8	41.0	54.0	-13.0	Average	Horizontal
*	13656.5	29.3	22.9	52.2	74.0	-21.8	Peak	Horizontal
*	16444.5	30.9	22.4	53.3	74.0	-20.7	Peak	Horizontal
	7426.0	37.7	14.2	51.9	74.0	-22.1	Peak	Vertical
	11565.5	34.2	20.8	55.0	74.0	-19.0	Peak	Vertical
	11569.7	24.8	20.8	45.6	54.0	-8.4	Average	Vertical
*	13869.0	29.6	23.6	53.2	74.0	-20.8	Peak	Vertical
*	16359.5	31.1	22.4	53.5	74.0	-20.5	Peak	Vertical

Note 1: "\*" is not in restricted band, its limit is -27dBm/MHz. At a distance of 3 meters, the field strength limit in dBμV/m can be determined by adding a "conversion" factor of 95.2dB to the EIRP limit of -27dBm/MHz to obtain the limit for out of band spurious emissions.

Note 2: Measure Level (dBμV/m) = Reading Level (dBμV) + Factor (dB)

Factor (dB) = Cable Loss (dB) + Antenna Factor (dB/m) – Pre\_Amplifier Gain (dB)

Product	Speed Dome Camera (1080P WiFi PTZ)	Temperature	22°C
Test Engineer	Snake Ni	Relative Humidity	51%
Test Site	AC2	Test Date	2018/01/23
Test Mode:	802.11a	Test Channel:	165
Remark:	1. Average measurement was not performed if peak level lower than average limit. 2. Other frequency was 20dB below limit line within 1-18GHz, there is not show in the report.		

Mark	Frequency (MHz)	Reading Level (dBμV)	Factor (dB)	Measure Level (dBμV/m)	Limit (dBμV/m)	Margin (dB)	Detector	Polarization
	7451.5	35.6	14.3	49.9	74.0	-24.1	Peak	Horizontal
	11565.5	35.3	20.8	56.1	74.0	-17.9	Peak	Horizontal
	11569.2	20.2	20.8	41.0	54.0	-13.0	Average	Horizontal
*	13656.5	29.3	22.9	52.2	74.0	-21.8	Peak	Horizontal
*	16444.5	30.9	22.4	53.3	74.0	-20.7	Peak	Horizontal
	7426.0	37.7	14.2	51.9	74.0	-22.1	Peak	Vertical
	11565.5	34.2	20.8	55.0	74.0	-19.0	Peak	Vertical
	11569.7	24.8	20.8	45.6	54.0	-8.4	Average	Vertical
*	13869.0	29.6	23.6	53.2	74.0	-20.8	Peak	Vertical
*	16359.5	31.1	22.4	53.5	74.0	-20.5	Peak	Vertical

Note 1: "\*" is not in restricted band, its limit is -27dBm/MHz. At a distance of 3 meters, the field strength limit in dBμV/m can be determined by adding a "conversion" factor of 95.2dB to the EIRP limit of -27dBm/MHz to obtain the limit for out of band spurious emissions.

Note 2: Measure Level (dBμV/m) = Reading Level (dBμV) + Factor (dB)

Factor (dB) = Cable Loss (dB) + Antenna Factor (dB/m) – Pre\_Amplifier Gain (dB)



Product	Speed Dome Camera (1080P WiFi PTZ)	Temperature	22°C
Test Engineer	Snake Ni	Relative Humidity	51%
Test Site	AC2	Test Date	2018/01/23
Test Mode:	802.11n-HT20	Test Channel:	36
Remark:	1. Average measurement was not performed if peak level lower than average limit. 2. Other frequency was 20dB below limit line within 1-18GHz, there is not show in the report.		

Mark	Frequency (MHz)	Reading Level (dBμV)	Factor (dB)	Measure Level (dBμV/m)	Limit (dBμV/m)	Margin (dB)	Detector	Polarization
	7545.0	35.9	14.4	50.3	74.0	-23.7	Peak	Horizontal
*	10384.0	32.1	18.8	50.9	74.0	-23.1	Peak	Horizontal
*	13682.0	29.9	22.6	52.5	74.0	-21.5	Peak	Horizontal
	16062.0	30.8	21.2	52.0	74.0	-22.0	Peak	Horizontal
	7400.5	38.2	13.9	52.1	74.0	-21.9	Peak	Vertical
*	10273.5	32.4	18.3	50.7	74.0	-23.3	Peak	Vertical
*	13886.0	29.1	23.7	52.8	74.0	-21.2	Peak	Vertical
	15662.5	30.7	21.2	51.9	74.0	-22.1	Peak	Vertical

Note 1: "\*" is not in restricted band, its limit is -27dBm/MHz. At a distance of 3 meters, the field strength limit in dBμV/m can be determined by adding a "conversion" factor of 95.2dB to the EIRP limit of -27dBm/MHz to obtain the limit for out of band spurious emissions.

Note 2: Measure Level (dBμV/m) = Reading Level (dBμV) + Factor (dB)

Factor (dB) = Cable Loss (dB) + Antenna Factor (dB/m) - Pre\_Amplifier Gain (dB)

Product	Speed Dome Camera (1080P WiFi PTZ)	Temperature	22°C
Test Engineer	Snake Ni	Relative Humidity	51%
Test Site	AC2	Test Date	2018/01/23
Test Mode:	802.11n-HT20	Test Channel:	44
Remark:	1. Average measurement was not performed if peak level lower than average limit. 2. Other frequency was 20dB below limit line within 1-18GHz, there is not show in the report.		

Mark	Frequency (MHz)	Reading Level (dBμV)	Factor (dB)	Measure Level (dBμV/m)	Limit (dBμV/m)	Margin (dB)	Detector	Polarization
	7417.5	36.1	14.1	50.2	74.0	-23.8	Peak	Horizontal
*	10494.5	32.2	18.9	51.1	74.0	-22.9	Peak	Horizontal
*	13563.0	29.1	23.0	52.1	74.0	-21.9	Peak	Horizontal
	15849.5	31.1	21.7	52.8	74.0	-21.2	Peak	Horizontal
	7366.5	38.7	13.9	52.6	74.0	-21.4	Peak	Vertical
*	10239.5	33.4	18.1	51.5	74.0	-22.5	Peak	Vertical
*	13571.5	29.1	22.9	52.0	74.0	-22.0	Peak	Vertical
	15705.0	31.2	21.2	52.4	74.0	-21.6	Peak	Vertical

Note 1: "\*" is not in restricted band, its limit is -27dBm/MHz. At a distance of 3 meters, the field strength limit in dBμV/m can be determined by adding a "conversion" factor of 95.2dB to the EIRP limit of -27dBm/MHz to obtain the limit for out of band spurious emissions.

Note 2: Measure Level (dBμV/m) = Reading Level (dBμV) + Factor (dB)

Factor (dB) = Cable Loss (dB) + Antenna Factor (dB/m) - Pre\_Amplifier Gain (dB)

Product	Speed Dome Camera (1080P WiFi PTZ)	Temperature	22°C
Test Engineer	Snake Ni	Relative Humidity	51%
Test Site	AC2	Test Date	2018/01/23
Test Mode:	802.11n-HT20	Test Channel:	48
Remark:	1. Average measurement was not performed if peak level lower than average limit. 2. Other frequency was 20dB below limit line within 1-18GHz, there is not show in the report.		

Mark	Frequency (MHz)	Reading Level (dBμV)	Factor (dB)	Measure Level (dBμV/m)	Limit (dBμV/m)	Margin (dB)	Detector	Polarization
	7417.5	35.9	14.1	50.0	74.0	-24.0	Peak	Horizontal
*	10273.5	32.7	18.3	51.0	74.0	-23.0	Peak	Horizontal
*	13673.5	29.6	22.7	52.3	74.0	-21.7	Peak	Horizontal
	15849.5	30.2	21.7	51.9	74.0	-22.1	Peak	Horizontal
	7417.5	38.5	14.1	52.6	74.0	-21.4	Peak	Vertical
*	10511.5	31.3	18.9	50.2	74.0	-23.8	Peak	Vertical
*	13877.5	29.1	23.7	52.8	74.0	-21.2	Peak	Vertical
	16062.0	30.3	21.2	51.5	74.0	-22.5	Peak	Vertical

Note 1: "\*" is not in restricted band, its limit is -27dBm/MHz. At a distance of 3 meters, the field strength limit in dBμV/m can be determined by adding a "conversion" factor of 95.2dB to the EIRP limit of -27dBm/MHz to obtain the limit for out of band spurious emissions.

Note 2: Measure Level (dBμV/m) = Reading Level (dBμV) + Factor (dB)

Factor (dB) = Cable Loss (dB) + Antenna Factor (dB/m) - Pre\_Amplifier Gain (dB)

Product	Speed Dome Camera (1080P WiFi PTZ)	Temperature	22°C
Test Engineer	Snake Ni	Relative Humidity	51%
Test Site	AC2	Test Date	2018/01/23
Test Mode:	802.11n-HT20	Test Channel:	149
Remark:	1. Average measurement was not performed if peak level lower than average limit. 2. Other frequency was 20dB below limit line within 1-18GHz, there is not show in the report.		

Mark	Frequency (MHz)	Reading Level (dBμV)	Factor (dB)	Measure Level (dBμV/m)	Limit (dBμV/m)	Margin (dB)	Detector	Polarization
	7426.0	35.8	14.2	50.0	74.0	-24.0	Peak	Horizontal
	11489.0	32.8	20.6	53.4	74.0	-20.6	Peak	Horizontal
	11490.8	22.0	20.6	42.6	54.0	-11.4	Average	Horizontal
*	13554.5	29.3	23.1	52.4	74.0	-21.6	Peak	Horizontal
*	16215.0	30.4	21.9	52.3	74.0	-21.7	Peak	Horizontal
	7417.5	38.7	14.1	52.8	74.0	-21.2	Peak	Vertical
	11480.5	31.4	20.6	52.0	74.0	-22.0	Peak	Vertical
*	13648.0	29.2	23.0	52.2	74.0	-21.8	Peak	Vertical
*	16478.5	31.3	22.5	53.8	74.0	-20.2	Peak	Vertical

Note 1: "\*" is not in restricted band, its limit is -27dBm/MHz. At a distance of 3 meters, the field strength limit in dBμV/m can be determined by adding a "conversion" factor of 95.2dB to the EIRP limit of -27dBm/MHz to obtain the limit for out of band spurious emissions.

Note 2: Measure Level (dBμV/m) = Reading Level (dBμV) + Factor (dB)

Factor (dB) = Cable Loss (dB) + Antenna Factor (dB/m) – Pre\_Amplifier Gain (dB)

Product	Speed Dome Camera (1080P WiFi PTZ)	Temperature	22°C
Test Engineer	Snake Ni	Relative Humidity	51%
Test Site	AC2	Test Date	2018/01/23
Test Mode:	802.11n-HT20	Test Channel:	157
Remark:	1. Average measurement was not performed if peak level lower than average limit. 2. Other frequency was 20dB below limit line within 1-18GHz, there is not show in the report.		

Mark	Frequency (MHz)	Reading Level (dBμV)	Factor (dB)	Measure Level (dBμV/m)	Limit (dBμV/m)	Margin (dB)	Detector	Polarization
	7341.0	35.6	13.9	49.5	74.0	-24.5	Peak	Horizontal
	11574.0	33.9	20.8	54.7	74.0	-19.3	Peak	Horizontal
	11575.8	23.4	20.8	44.2	54.0	-9.8	Average	Horizontal
*	13775.5	29.7	23.1	52.8	74.0	-21.2	Peak	Horizontal
*	16393.5	31.1	22.3	53.4	74.0	-20.6	Peak	Horizontal
	7443.0	37.6	14.3	51.9	74.0	-22.1	Peak	Vertical
	11569.2	24.2	20.8	45.0	54.0	-9.0	Average	Vertical
	11574.0	34.8	20.8	55.6	74.0	-18.4	Peak	Vertical
*	13682.0	29.7	22.6	52.3	74.0	-21.7	Peak	Vertical
*	16427.5	31.4	22.3	53.7	74.0	-20.3	Peak	Vertical

Note 1: "\*" is not in restricted band, its limit is -27dBm/MHz. At a distance of 3 meters, the field strength limit in dBμV/m can be determined by adding a "conversion" factor of 95.2dB to the EIRP limit of -27dBm/MHz to obtain the limit for out of band spurious emissions.

Note 2: Measure Level (dBμV/m) = Reading Level (dBμV) + Factor (dB)

Factor (dB) = Cable Loss (dB) + Antenna Factor (dB/m) – Pre\_Amplifier Gain (dB)

Product	Speed Dome Camera (1080P WiFi PTZ)	Temperature	22°C
Test Engineer	Snake Ni	Relative Humidity	51%
Test Site	AC2	Test Date	2018/01/23
Test Mode:	802.11n-HT20	Test Channel:	165
Remark:	1. Average measurement was not performed if peak level lower than average limit. 2. Other frequency was 20dB below limit line within 1-18GHz, there is not show in the report.		

Mark	Frequency (MHz)	Reading Level (dBμV)	Factor (dB)	Measure Level (dBμV/m)	Limit (dBμV/m)	Margin (dB)	Detector	Polarization
	7426.0	36.1	14.2	50.3	74.0	-23.7	Peak	Horizontal
	11650.2	23.9	21.0	44.9	54.0	-9.1	Average	Horizontal
	11650.5	33.8	21.0	54.8	74.0	-19.2	Peak	Horizontal
*	13682.0	30.1	22.6	52.7	74.0	-21.3	Peak	Horizontal
*	16393.5	31.3	22.3	53.6	74.0	-20.4	Peak	Horizontal
	7324.0	38.3	13.8	52.1	74.0	-21.9	Peak	Vertical
	11649.9	24.2	21.0	45.2	54.0	-8.8	Average	Vertical
	11650.5	33.5	21.0	54.5	74.0	-19.5	Peak	Vertical
*	13673.5	29.6	22.7	52.3	74.0	-21.7	Peak	Vertical
*	16410.5	31.1	22.3	53.4	74.0	-20.6	Peak	Vertical

Note 1: "\*" is not in restricted band, its limit is -27dBm/MHz. At a distance of 3 meters, the field strength limit in dBμV/m can be determined by adding a "conversion" factor of 95.2dB to the EIRP limit of -27dBm/MHz to obtain the limit for out of band spurious emissions.

Note 2: Measure Level (dBμV/m) = Reading Level (dBμV) + Factor (dB)

Factor (dB) = Cable Loss (dB) + Antenna Factor (dB/m) – Pre\_Amplifier Gain (dB)

Product	Speed Dome Camera (1080P WiFi PTZ)	Temperature	22°C
Test Engineer	Snake Ni	Relative Humidity	51%
Test Site	AC2	Test Date	2018/01/23
Test Mode:	802.11n-HT40	Test Channel:	38
Remark:	1. Average measurement was not performed if peak level lower than average limit. 2. Other frequency was 20dB below limit line within 1-18GHz, there is not show in the report.		

Mark	Frequency (MHz)	Reading Level (dBμV)	Factor (dB)	Measure Level (dBμV/m)	Limit (dBμV/m)	Margin (dB)	Detector	Polarization
	7324.0	36.1	13.8	49.9	74.0	-24.1	Peak	Horizontal
*	10265.0	33.4	18.2	51.6	74.0	-22.4	Peak	Horizontal
*	13673.5	29.8	22.7	52.5	74.0	-21.5	Peak	Horizontal
	16019.5	30.7	21.1	51.8	74.0	-22.2	Peak	Horizontal
	7545.0	34.0	14.4	48.4	74.0	-25.6	Peak	Vertical
*	10375.5	31.1	18.7	49.8	74.0	-24.2	Peak	Vertical
*	13537.5	28.4	23.2	51.6	74.0	-22.4	Peak	Vertical
	15705.0	30.9	21.2	52.1	74.0	-21.9	Peak	Vertical

Note 1: "\*" is not in restricted band, its limit is -27dBm/MHz. At a distance of 3 meters, the field strength limit in dBμV/m can be determined by adding a "conversion" factor of 95.2dB to the EIRP limit of -27dBm/MHz to obtain the limit for out of band spurious emissions.

Note 2: Measure Level (dBμV/m) = Reading Level (dBμV) + Factor (dB)

Factor (dB) = Cable Loss (dB) + Antenna Factor (dB/m) - Pre\_Amplifier Gain (dB)

Product	Speed Dome Camera (1080P WiFi PTZ)	Temperature	22°C
Test Engineer	Snake Ni	Relative Humidity	51%
Test Site	AC2	Test Date	2018/01/23
Test Mode:	802.11n-HT40	Test Channel:	46
Remark:	1. Average measurement was not performed if peak level lower than average limit. 2. Other frequency was 20dB below limit line within 1-18GHz, there is not show in the report.		

Mark	Frequency (MHz)	Reading Level (dBμV)	Factor (dB)	Measure Level (dBμV/m)	Limit (dBμV/m)	Margin (dB)	Detector	Polarization
	7553.5	35.9	14.3	50.2	74.0	-23.8	Peak	Horizontal
*	10469.0	31.8	18.7	50.5	74.0	-23.5	Peak	Horizontal
*	13554.5	29.1	23.1	52.2	74.0	-21.8	Peak	Horizontal
	15671.0	30.8	21.1	51.9	74.0	-22.1	Peak	Horizontal
	7426.0	38.6	14.2	52.8	74.0	-21.2	Peak	Vertical
*	10435.0	32.1	18.4	50.5	74.0	-23.5	Peak	Vertical
*	13682.0	29.8	22.6	52.4	74.0	-21.6	Peak	Vertical
	15654.0	31.0	21.2	52.2	74.0	-21.8	Peak	Vertical

Note 1: "\*" is not in restricted band, its limit is -27dBm/MHz. At a distance of 3 meters, the field strength limit in dBμV/m can be determined by adding a "conversion" factor of 95.2dB to the EIRP limit of -27dBm/MHz to obtain the limit for out of band spurious emissions.

Note 2: Measure Level (dBμV/m) = Reading Level (dBμV) + Factor (dB)

Factor (dB) = Cable Loss (dB) + Antenna Factor (dB/m) - Pre\_Amplifier Gain (dB)



Product	Speed Dome Camera (1080P WiFi PTZ)	Temperature	22°C
Test Engineer	Snake Ni	Relative Humidity	51%
Test Site	AC2	Test Date	2018/01/23
Test Mode:	802.11n-HT40	Test Channel:	151
Remark:	1. Average measurement was not performed if peak level lower than average limit. 2. Other frequency was 20dB below limit line within 1-18GHz, there is not show in the report.		

Mark	Frequency (MHz)	Reading Level (dBμV)	Factor (dB)	Measure Level (dBμV/m)	Limit (dBμV/m)	Margin (dB)	Detector	Polarization
	7460.0	35.6	14.2	49.8	74.0	-24.2	Peak	Horizontal
	11514.5	31.1	20.6	51.7	74.0	-22.3	Peak	Horizontal
*	13673.5	29.9	22.7	52.6	74.0	-21.4	Peak	Horizontal
*	16385.0	31.2	22.3	53.5	74.0	-20.5	Peak	Horizontal
	7519.5	37.2	14.4	51.6	74.0	-22.4	Peak	Vertical
	11506.0	31.1	20.6	51.7	74.0	-22.3	Peak	Vertical
*	13869.0	29.3	23.6	52.9	74.0	-21.1	Peak	Vertical
*	16427.5	31.4	22.3	53.7	74.0	-20.3	Peak	Vertical

Note 1: "\*" is not in restricted band, its limit is -27dBm/MHz. At a distance of 3 meters, the field strength limit in dBμV/m can be determined by adding a "conversion" factor of 95.2dB to the EIRP limit of -27dBm/MHz to obtain the limit for out of band spurious emissions.

Note 2: Measure Level (dBμV/m) = Reading Level (dBμV) + Factor (dB)

Factor (dB) = Cable Loss (dB) + Antenna Factor (dB/m) – Pre\_Amplifier Gain (dB)

Product	Speed Dome Camera (1080P WiFi PTZ)	Temperature	22°C
Test Engineer	Snake Ni	Relative Humidity	51%
Test Site	AC2	Test Date	2018/01/23
Test Mode:	802.11n-HT40	Test Channel:	159
Remark:	1. Average measurement was not performed if peak level lower than average limit. 2. Other frequency was 20dB below limit line within 1-18GHz, there is not show in the report.		

Mark	Frequency (MHz)	Reading Level (dBμV)	Factor (dB)	Measure Level (dBμV/m)	Limit (dBμV/m)	Margin (dB)	Detector	Polarization
	7400.5	36.3	13.9	50.2	74.0	-23.8	Peak	Horizontal
	11574.0	33.1	20.8	53.9	74.0	-20.1	Peak	Horizontal
	11587.2	21.2	20.7	41.9	54.0	-12.1	Average	Horizontal
*	13673.5	29.7	22.7	52.4	74.0	-21.6	Peak	Horizontal
*	16504.0	31.1	22.6	53.7	74.0	-20.3	Peak	Horizontal
	7434.5	37.2	14.3	51.5	74.0	-22.5	Peak	Vertical
	11591.0	33.8	20.7	54.5	74.0	-19.5	Peak	Vertical
	11590.2	22.6	20.7	43.3	54.0	-10.7	Average	Vertical
*	13869.0	29.5	23.6	53.1	74.0	-20.9	Peak	Vertical
*	16393.5	30.9	22.3	53.2	74.0	-20.8	Peak	Vertical

Note 1: "\*" is not in restricted band, its limit is -27dBm/MHz. At a distance of 3 meters, the field strength limit in dBμV/m can be determined by adding a "conversion" factor of 95.2dB to the EIRP limit of -27dBm/MHz to obtain the limit for out of band spurious emissions.

Note 2: Measure Level (dBμV/m) = Reading Level (dBμV) + Factor (dB)

Factor (dB) = Cable Loss (dB) + Antenna Factor (dB/m) – Pre\_Amplifier Gain (dB)

Product	Speed Dome Camera (1080P WiFi PTZ)	Temperature	22°C
Test Engineer	Snake Ni	Relative Humidity	51%
Test Site	AC2	Test Date	2018/01/23
Test Mode:	802.11ac-VHT20	Test Channel:	36
Remark:	1. Average measurement was not performed if peak level lower than average limit. 2. Other frequency was 20dB below limit line within 1-18GHz, there is not show in the report.		

Mark	Frequency (MHz)	Reading Level (dBμV)	Factor (dB)	Measure Level (dBμV/m)	Limit (dBμV/m)	Margin (dB)	Detector	Polarization
	7332.5	35.4	13.9	49.3	74.0	-24.7	Peak	Horizontal
*	10384.0	31.4	18.8	50.2	74.0	-23.8	Peak	Horizontal
*	13665.0	29.8	22.8	52.6	74.0	-21.4	Peak	Horizontal
	15526.5	30.8	21.6	52.4	74.0	-21.6	Peak	Horizontal
	7443.0	38.3	14.3	52.6	74.0	-21.4	Peak	Vertical
*	10350.0	31.7	18.5	50.2	74.0	-23.8	Peak	Vertical
*	13571.5	29.0	22.9	51.9	74.0	-22.1	Peak	Vertical
	15790.0	30.4	21.5	51.9	74.0	-22.1	Peak	Vertical

Note 1: "\*" is not in restricted band, its limit is -27dBm/MHz. At a distance of 3 meters, the field strength limit in dBμV/m can be determined by adding a "conversion" factor of 95.2dB to the EIRP limit of -27dBm/MHz to obtain the limit for out of band spurious emissions.

Note 2: Measure Level (dBμV/m) = Reading Level (dBμV) + Factor (dB)

Factor (dB) = Cable Loss (dB) + Antenna Factor (dB/m) - Pre\_Amplifier Gain (dB)

Product	Speed Dome Camera (1080P WiFi PTZ)	Temperature	22°C
Test Engineer	Snake Ni	Relative Humidity	51%
Test Site	AC2	Test Date	2018/01/23
Test Mode:	802.11ac-VHT20	Test Channel:	44
Remark:	1. Average measurement was not performed if peak level lower than average limit. 2. Other frequency was 20dB below limit line within 1-18GHz, there is not show in the report.		

Mark	Frequency (MHz)	Reading Level (dBμV)	Factor (dB)	Measure Level (dBμV/m)	Limit (dBμV/m)	Margin (dB)	Detector	Polarization
	7426.0	35.5	14.2	49.7	74.0	-24.3	Peak	Horizontal
*	10460.5	31.1	18.6	49.7	74.0	-24.3	Peak	Horizontal
*	13554.5	28.9	23.1	52.0	74.0	-22.0	Peak	Horizontal
	15569.0	31.2	21.4	52.6	74.0	-21.4	Peak	Horizontal
	7426.0	37.8	14.2	52.0	74.0	-22.0	Peak	Vertical
*	10477.5	32.0	18.8	50.8	74.0	-23.2	Peak	Vertical
*	13605.5	29.4	23.1	52.5	74.0	-21.5	Peak	Vertical
	15560.5	31.2	21.4	52.6	74.0	-21.4	Peak	Vertical

Note 1: "\*" is not in restricted band, its limit is -27dBm/MHz. At a distance of 3 meters, the field strength limit in dBμV/m can be determined by adding a "conversion" factor of 95.2dB to the EIRP limit of -27dBm/MHz to obtain the limit for out of band spurious emissions.

Note 2: Measure Level (dBμV/m) = Reading Level (dBμV) + Factor (dB)

Factor (dB) = Cable Loss (dB) + Antenna Factor (dB/m) - Pre\_Amplifier Gain (dB)

Product	Speed Dome Camera (1080P WiFi PTZ)	Temperature	22°C
Test Engineer	Snake Ni	Relative Humidity	51%
Test Site	AC2	Test Date	2018/01/23
Test Mode:	802.11ac-VHT20	Test Channel:	48
Remark:	1. Average measurement was not performed if peak level lower than average limit. 2. Other frequency was 20dB below limit line within 1-18GHz, there is not show in the report.		

Mark	Frequency (MHz)	Reading Level (dBμV)	Factor (dB)	Measure Level (dBμV/m)	Limit (dBμV/m)	Margin (dB)	Detector	Polarization
	7426.0	35.5	14.2	49.7	74.0	-24.3	Peak	Horizontal
*	10494.5	32.4	18.9	51.3	74.0	-22.7	Peak	Horizontal
*	13571.5	29.1	22.9	52.0	74.0	-22.0	Peak	Horizontal
	15781.5	30.3	21.5	51.8	74.0	-22.2	Peak	Horizontal
	7426.0	37.9	14.2	52.1	74.0	-21.9	Peak	Vertical
*	10486.0	32.4	18.9	51.3	74.0	-22.7	Peak	Vertical
*	13580.0	29.2	22.8	52.0	74.0	-22.0	Peak	Vertical
	15790.0	30.1	21.5	51.6	74.0	-22.4	Peak	Vertical

Note 1: "\*" is not in restricted band, its limit is -27dBm/MHz. At a distance of 3 meters, the field strength limit in dBμV/m can be determined by adding a "conversion" factor of 95.2dB to the EIRP limit of -27dBm/MHz to obtain the limit for out of band spurious emissions.

Note 2: Measure Level (dBμV/m) = Reading Level (dBμV) + Factor (dB)

Factor (dB) = Cable Loss (dB) + Antenna Factor (dB/m) - Pre\_Amplifier Gain (dB)

Product	Speed Dome Camera (1080P WiFi PTZ)	Temperature	22°C
Test Engineer	Snake Ni	Relative Humidity	51%
Test Site	AC2	Test Date	2018/01/23
Test Mode:	802.11ac-VHT20	Test Channel:	149
Remark:	1. Average measurement was not performed if peak level lower than average limit. 2. Other frequency was 20dB below limit line within 1-18GHz, there is not show in the report.		

Mark	Frequency (MHz)	Reading Level (dBμV)	Factor (dB)	Measure Level (dBμV/m)	Limit (dBμV/m)	Margin (dB)	Detector	Polarization
	7528.0	35.9	14.5	50.4	74.0	-23.6	Peak	Horizontal
	11489.0	32.9	20.6	53.5	74.0	-20.5	Peak	Horizontal
	11493.8	21.5	20.6	42.1	54.0	-11.9	Average	Horizontal
*	13546.0	29.2	23.2	52.4	74.0	-21.6	Peak	Horizontal
*	16419.0	31.1	22.3	53.4	74.0	-20.6	Peak	Horizontal
	7392.0	37.7	13.8	51.5	74.0	-22.5	Peak	Vertical
	11489.0	31.5	20.6	52.1	74.0	-21.9	Peak	Vertical
*	13563.0	29.1	23.0	52.1	74.0	-21.9	Peak	Vertical
*	16351.0	31.1	22.4	53.5	74.0	-20.5	Peak	Vertical

Note 1: "\*" is not in restricted band, its limit is -27dBm/MHz. At a distance of 3 meters, the field strength limit in dBμV/m can be determined by adding a "conversion" factor of 95.2dB to the EIRP limit of -27dBm/MHz to obtain the limit for out of band spurious emissions.

Note 2: Measure Level (dBμV/m) = Reading Level (dBμV) + Factor (dB)

Factor (dB) = Cable Loss (dB) + Antenna Factor (dB/m) - Pre\_Amplifier Gain (dB)

Product	Speed Dome Camera (1080P WiFi PTZ)	Temperature	22°C
Test Engineer	Snake Ni	Relative Humidity	51%
Test Site	AC2	Test Date	2018/01/23
Test Mode:	802.11ac-VHT20	Test Channel:	157
Remark:	1. Average measurement was not performed if peak level lower than average limit. 2. Other frequency was 20dB below limit line within 1-18GHz, there is not show in the report.		

Mark	Frequency (MHz)	Reading Level (dBμV)	Factor (dB)	Measure Level (dBμV/m)	Limit (dBμV/m)	Margin (dB)	Detector	Polarization
	7417.5	35.5	14.1	49.6	74.0	-24.4	Peak	Horizontal
	11565.5	34.3	20.8	55.1	74.0	-18.9	Peak	Horizontal
	11569.9	23.0	20.8	43.8	54.0	-10.2	Average	Horizontal
*	13580.0	29.0	22.8	51.8	74.0	-22.2	Peak	Horizontal
*	16223.5	30.6	22.0	52.6	74.0	-21.4	Peak	Horizontal
	7409.0	38.0	13.9	51.9	74.0	-22.1	Peak	Vertical
	11574.0	33.8	20.8	54.6	74.0	-19.4	Peak	Vertical
	11568.8	23.8	20.8	44.6	54.0	-9.4	Average	Vertical
*	13605.5	29.5	23.1	52.6	74.0	-21.4	Peak	Vertical

Note 1: "\*" is not in restricted band, its limit is -27dBm/MHz. At a distance of 3 meters, the field strength limit in dBμV/m can be determined by adding a "conversion" factor of 95.2dB to the EIRP limit of -27dBm/MHz to obtain the limit for out of band spurious emissions.

Note 2: Measure Level (dBμV/m) = Reading Level (dBμV) + Factor (dB)

Factor (dB) = Cable Loss (dB) + Antenna Factor (dB/m) - Pre\_Amplifier Gain (dB)

Product	Speed Dome Camera (1080P WiFi PTZ)	Temperature	22°C
Test Engineer	Snake Ni	Relative Humidity	51%
Test Site	AC2	Test Date	2018/01/23
Test Mode:	802.11ac-VHT20	Test Channel:	165
Remark:	1. Average measurement was not performed if peak level lower than average limit. 2. Other frequency was 20dB below limit line within 1-18GHz, there is not show in the report.		

Mark	Frequency (MHz)	Reading Level (dBμV)	Factor (dB)	Measure Level (dBμV/m)	Limit (dBμV/m)	Margin (dB)	Detector	Polarization
	7332.5	36.2	13.9	50.1	74.0	-23.9	Peak	Horizontal
	11650.5	34.0	21.0	55.0	74.0	-19.0	Peak	Horizontal
	11650.3	23.6	21.0	44.6	54.0	-9.4	Average	Horizontal
*	13554.5	29.1	23.1	52.2	74.0	-21.8	Peak	Horizontal
*	16368.0	31.0	22.4	53.4	74.0	-20.6	Peak	Horizontal
	7451.5	38.4	14.3	52.7	74.0	-21.3	Peak	Vertical
	11650.5	33.1	21.0	54.1	74.0	-19.9	Peak	Vertical
	11650.7	24.0	21.0	45.0	54.0	-9.0	Average	Vertical
*	13546.0	28.9	23.2	52.1	74.0	-21.9	Peak	Vertical
*	16223.5	30.8	22.0	52.8	74.0	-21.2	Peak	Vertical

Note 1: "\*" is not in restricted band, its limit is -27dBm/MHz. At a distance of 3 meters, the field strength limit in dBμV/m can be determined by adding a "conversion" factor of 95.2dB to the EIRP limit of -27dBm/MHz to obtain the limit for out of band spurious emissions.

Note 2: Measure Level (dBμV/m) = Reading Level (dBμV) + Factor (dB)

Factor (dB) = Cable Loss (dB) + Antenna Factor (dB/m) - Pre\_Amplifier Gain (dB)



Product	Speed Dome Camera (1080P WiFi PTZ)	Temperature	22°C
Test Engineer	Snake Ni	Relative Humidity	51%
Test Site	AC2	Test Date	2018/01/23
Test Mode:	802.11ac-VHT40	Test Channel:	38
Remark:	1. Average measurement was not performed if peak level lower than average limit. 2. Other frequency was 20dB below limit line within 1-18GHz, there is not show in the report.		

Mark	Frequency (MHz)	Reading Level (dBμV)	Factor (dB)	Measure Level (dBμV/m)	Limit (dBμV/m)	Margin (dB)	Detector	Polarization
	7451.5	35.5	14.3	49.8	74.0	-24.2	Peak	Horizontal
*	10375.5	32.0	18.7	50.7	74.0	-23.3	Peak	Horizontal
*	13673.5	30.2	22.7	52.9	74.0	-21.1	Peak	Horizontal
	15492.5	31.1	21.7	52.8	74.0	-21.2	Peak	Horizontal
	7511.0	37.2	14.3	51.5	74.0	-22.5	Peak	Vertical
*	10375.5	30.9	18.7	49.6	74.0	-24.4	Peak	Vertical
*	13554.5	28.7	23.1	51.8	74.0	-22.2	Peak	Vertical
	15705.0	30.8	21.2	52.0	74.0	-22.0	Peak	Vertical

Note 1: "\*" is not in restricted band, its limit is -27dBm/MHz. At a distance of 3 meters, the field strength limit in dBμV/m can be determined by adding a "conversion" factor of 95.2dB to the EIRP limit of -27dBm/MHz to obtain the limit for out of band spurious emissions.

Note 2: Measure Level (dBμV/m) = Reading Level (dBμV) + Factor (dB)

Factor (dB) = Cable Loss (dB) + Antenna Factor (dB/m) - Pre\_Amplifier Gain (dB)

Product	Speed Dome Camera (1080P WiFi PTZ)	Temperature	22°C
Test Engineer	Snake Ni	Relative Humidity	51%
Test Site	AC2	Test Date	2018/01/23
Test Mode:	802.11ac-VHT40	Test Channel:	46
Remark:	1. Average measurement was not performed if peak level lower than average limit. 2. Other frequency was 20dB below limit line within 1-18GHz, there is not show in the report.		

Mark	Frequency (MHz)	Reading Level (dBμV)	Factor (dB)	Measure Level (dBμV/m)	Limit (dBμV/m)	Margin (dB)	Detector	Polarization
	7400.5	35.3	13.9	49.2	74.0	-24.8	Peak	Horizontal
*	10418.0	32.5	18.6	51.1	74.0	-22.9	Peak	Horizontal
*	13571.5	29.3	22.9	52.2	74.0	-21.8	Peak	Horizontal
	15705.0	31.1	21.2	52.3	74.0	-21.7	Peak	Horizontal
	7426.0	38.6	14.2	52.8	74.0	-21.2	Peak	Vertical
*	10435.0	32.1	18.4	50.5	74.0	-23.5	Peak	Vertical
*	13682.0	29.8	22.6	52.4	74.0	-21.6	Peak	Vertical
	16019.5	30.4	21.1	51.5	74.0	-22.5	Peak	Vertical

Note 1: "\*" is not in restricted band, its limit is -27dBm/MHz. At a distance of 3 meters, the field strength limit in dBμV/m can be determined by adding a "conversion" factor of 95.2dB to the EIRP limit of -27dBm/MHz to obtain the limit for out of band spurious emissions.

Note 2: Measure Level (dBμV/m) = Reading Level (dBμV) + Factor (dB)

Factor (dB) = Cable Loss (dB) + Antenna Factor (dB/m) - Pre\_Amplifier Gain (dB)

Product	Speed Dome Camera (1080P WiFi PTZ)	Temperature	22°C
Test Engineer	Snake Ni	Relative Humidity	51%
Test Site	AC2	Test Date	2018/01/23
Test Mode:	802.11ac-VHT40	Test Channel:	151
Remark:	1. Average measurement was not performed if peak level lower than average limit. 2. Other frequency was 20dB below limit line within 1-18GHz, there is not show in the report.		

Mark	Frequency (MHz)	Reading Level (dBμV)	Factor (dB)	Measure Level (dBμV/m)	Limit (dBμV/m)	Margin (dB)	Detector	Polarization
	7426.0	36.7	14.2	50.9	74.0	-23.1	Peak	Horizontal
	11514.5	32.4	20.6	53.0	74.0	-21.0	Peak	Horizontal
	11511.3	21.2	20.6	41.8	54.0	-12.2	Average	Horizontal
*	13673.5	30.1	22.7	52.8	74.0	-21.2	Peak	Horizontal
*	16444.5	31.2	22.4	53.6	74.0	-20.4	Peak	Horizontal
	7375.0	37.1	13.9	51.0	74.0	-23.0	Peak	Vertical
	11514.5	33.8	20.6	54.4	74.0	-19.6	Peak	Vertical
	11514.7	20.7	20.6	41.3	54.0	-12.7	Average	Vertical
*	13869.0	29.5	23.6	53.1	74.0	-20.9	Peak	Vertical
*	16351.0	31.1	22.4	53.5	74.0	-20.5	Peak	Vertical

Note 1: "\*" is not in restricted band, its limit is -27dBm/MHz. At a distance of 3 meters, the field strength limit in dBμV/m can be determined by adding a "conversion" factor of 95.2dB to the EIRP limit of -27dBm/MHz to obtain the limit for out of band spurious emissions.

Note 2: Measure Level (dBμV/m) = Reading Level (dBμV) + Factor (dB)

Factor (dB) = Cable Loss (dB) + Antenna Factor (dB/m) - Pre\_Amplifier Gain (dB)

Product	Speed Dome Camera (1080P WiFi PTZ)	Temperature	22°C
Test Engineer	Snake Ni	Relative Humidity	51%
Test Site	AC2	Test Date	2018/01/23
Test Mode:	802.11ac-VHT40	Test Channel:	159
Remark:	1. Average measurement was not performed if peak level lower than average limit. 2. Other frequency was 20dB below limit line within 1-18GHz, there is not show in the report.		

Mark	Frequency (MHz)	Reading Level (dBμV)	Factor (dB)	Measure Level (dBμV/m)	Limit (dBμV/m)	Margin (dB)	Detector	Polarization
	7426.0	34.8	14.2	49.0	74.0	-25.0	Peak	Horizontal
	11582.5	32.0	20.7	52.7	74.0	-21.3	Peak	Horizontal
	11581.2	20.6	20.8	41.4	54.0	-12.6	Average	Horizontal
*	13605.5	29.8	23.1	52.9	74.0	-21.1	Peak	Horizontal
*	16359.5	31.1	22.4	53.5	74.0	-20.5	Peak	Horizontal
	7400.5	38.0	13.9	51.9	74.0	-22.1	Peak	Vertical
	11591.0	32.4	20.7	53.1	74.0	-20.9	Peak	Vertical
	11590.4	21.1	20.7	41.8	54.0	-12.2	Average	Vertical
*	13665.0	29.8	22.8	52.6	74.0	-21.4	Peak	Vertical
*	16470.0	31.1	22.5	53.6	74.0	-20.4	Peak	Vertical

Note 1: "\*" is not in restricted band, its limit is -27dBm/MHz. At a distance of 3 meters, the field strength limit in dBμV/m can be determined by adding a "conversion" factor of 95.2dB to the EIRP limit of -27dBm/MHz to obtain the limit for out of band spurious emissions.

Note 2: Measure Level (dBμV/m) = Reading Level (dBμV) + Factor (dB)

Factor (dB) = Cable Loss (dB) + Antenna Factor (dB/m) - Pre\_Amplifier Gain (dB)

Product	Speed Dome Camera (1080P WiFi PTZ)	Temperature	22°C
Test Engineer	Snake Ni	Relative Humidity	51%
Test Site	AC2	Test Date	2018/01/23
Test Mode:	802.11ac-VHT80	Test Channel:	42
Remark:	<ol style="list-style-type: none"> <li>Average measurement was not performed if peak level lower than average limit.</li> <li>Other frequency was 20dB below limit line within 1-18GHz, there is not show in the report.</li> </ol>		

Mark	Frequency (MHz)	Reading Level (dBμV)	Factor (dB)	Measure Level (dBμV/m)	Limit (dBμV/m)	Margin (dB)	Detector	Polarization
	7400.5	35.6	13.9	49.5	74.0	-24.5	Peak	Horizontal
*	10401.0	32.0	18.7	50.7	74.0	-23.3	Peak	Horizontal
*	13860.5	29.4	23.7	53.1	74.0	-20.9	Peak	Horizontal
	15611.5	30.7	21.1	51.8	74.0	-22.2	Peak	Horizontal
	7434.5	38.4	14.3	52.7	74.0	-21.3	Peak	Vertical
*	10418.0	31.3	18.6	49.9	74.0	-24.1	Peak	Vertical
*	13775.5	29.8	23.1	52.9	74.0	-21.1	Peak	Vertical
	15773.0	30.3	21.5	51.8	74.0	-22.2	Peak	Vertical

Note 1: "\*" is not in restricted band, its limit is -27dBm/MHz. At a distance of 3 meters, the field strength limit in dBμV/m can be determined by adding a "conversion" factor of 95.2dB to the EIRP limit of -27dBm/MHz to obtain the limit for out of band spurious emissions.

Note 2: Measure Level (dBμV/m) = Reading Level (dBμV) + Factor (dB)

Factor (dB) = Cable Loss (dB) + Antenna Factor (dB/m) - Pre\_Amplifier Gain (dB)

Product	Speed Dome Camera (1080P WiFi PTZ)	Temperature	22°C
Test Engineer	Snake Ni	Relative Humidity	51%
Test Site	AC2	Test Date	2018/01/23
Test Mode:	802.11ac-VHT80	Test Channel:	155
Remark:	1. Average measurement was not performed if peak level lower than average limit. 2. Other frequency was 20dB below limit line within 1-18GHz, there is not show in the report.		

Mark	Frequency (MHz)	Reading Level (dBμV)	Factor (dB)	Measure Level (dBμV/m)	Limit (dBμV/m)	Margin (dB)	Detector	Polarization
	7400.5	36.1	13.9	50.0	74.0	-24.0	Peak	Horizontal
	11497.5	31.3	20.6	51.9	74.0	-22.1	Peak	Horizontal
*	13580.0	28.8	22.8	51.6	74.0	-22.4	Peak	Horizontal
*	16240.5	30.8	22.1	52.9	74.0	-21.1	Peak	Horizontal
	7519.5	36.8	14.4	51.2	74.0	-22.8	Peak	Vertical
	11497.5	30.9	20.6	51.5	74.0	-22.5	Peak	Vertical
*	13673.5	30.5	22.7	53.2	74.0	-20.8	Peak	Vertical
*	16317.0	30.9	22.3	53.2	74.0	-20.8	Peak	Vertical

Note 1: "\*" is not in restricted band, its limit is -27dBm/MHz. At a distance of 3 meters, the field strength limit in dBμV/m can be determined by adding a "conversion" factor of 95.2dB to the EIRP limit of -27dBm/MHz to obtain the limit for out of band spurious emissions.

Note 2: Measure Level (dBμV/m) = Reading Level (dBμV) + Factor (dB)

Factor (dB) = Cable Loss (dB) + Antenna Factor (dB/m) - Pre\_Amplifier Gain (dB)

**The Worst Case of Radiated Emission below 1GHz:**

Site: AC2	Time: 2018/01/23 - 20:11
Limit: FCC_Part15.209_RE(3m)	Engineer: Alex Ma
Probe: VULB 9168 _20-2000MHz	Polarity: Horizontal
EUT: Speed Dome Camera (1080P WiFi PTZ)	Power: AC 120V/60Hz
<b>Worse Case Mode:</b> Transmit by 802.11ac-VHT20 at Channel 5180MHz	

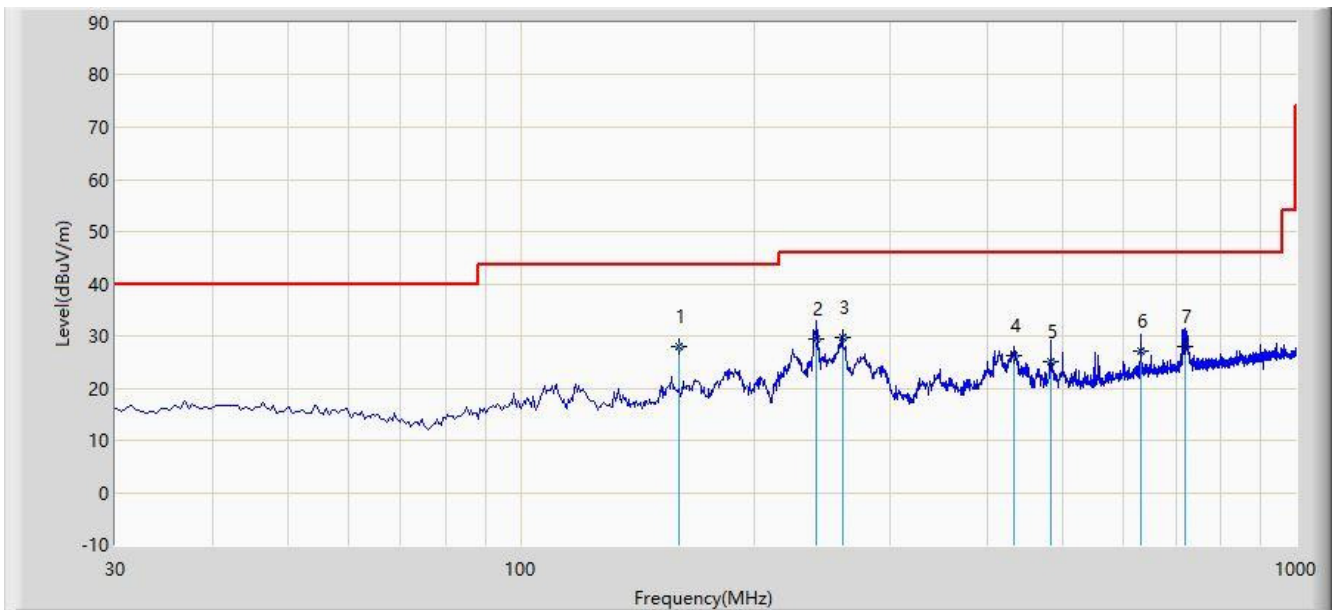

No	Flag	Mark	Frequency (MHz)	Measure Level (dBuV/m)	Reading Level (dBuV)	Over Limit (dB)	Limit (dBuV/m)	Factor	Type
1		*	159.890	28.006	13.901	-15.494	43.500	14.105	QP
2			240.975	29.544	18.083	-16.456	46.000	11.461	QP
3			259.890	29.662	17.891	-16.338	46.000	11.771	QP
4			432.550	26.165	10.607	-19.835	46.000	15.558	QP
5			482.505	25.145	8.852	-20.855	46.000	16.293	QP
6			631.400	27.086	8.209	-18.914	46.000	18.877	QP
7			718.700	28.001	8.114	-17.999	46.000	19.887	QP

Note 1: Measure Level (dBuV/m) = Reading Level (dBuV) + Factor (dB)

Factor (dB) = Cable Loss (dB) + Antenna Factor (dB/m)

Note 2: The test trace is same as the ambient noise and the amplitude of the emissions are attenuated more than 20dB below the permissible (the test frequency range: 9kHz ~ 30MHz, 18GHz ~ 25GHz), therefore no data appear in the report.

Site: AC2	Time: 2018/01/23 - 20:14
Limit: FCC_Part15.209_RE(3m)	Engineer: Alex Ma
Probe: VULB 9168 _20-2000MHz	Polarity: Horizontal
EUT: Speed Dome Camera (1080P WiFi PTZ)	Power: AC 120V/60Hz
<b>Worse Case Mode:</b> Transmit by 802.11ac-VHT20 at Channel 5180MHz	

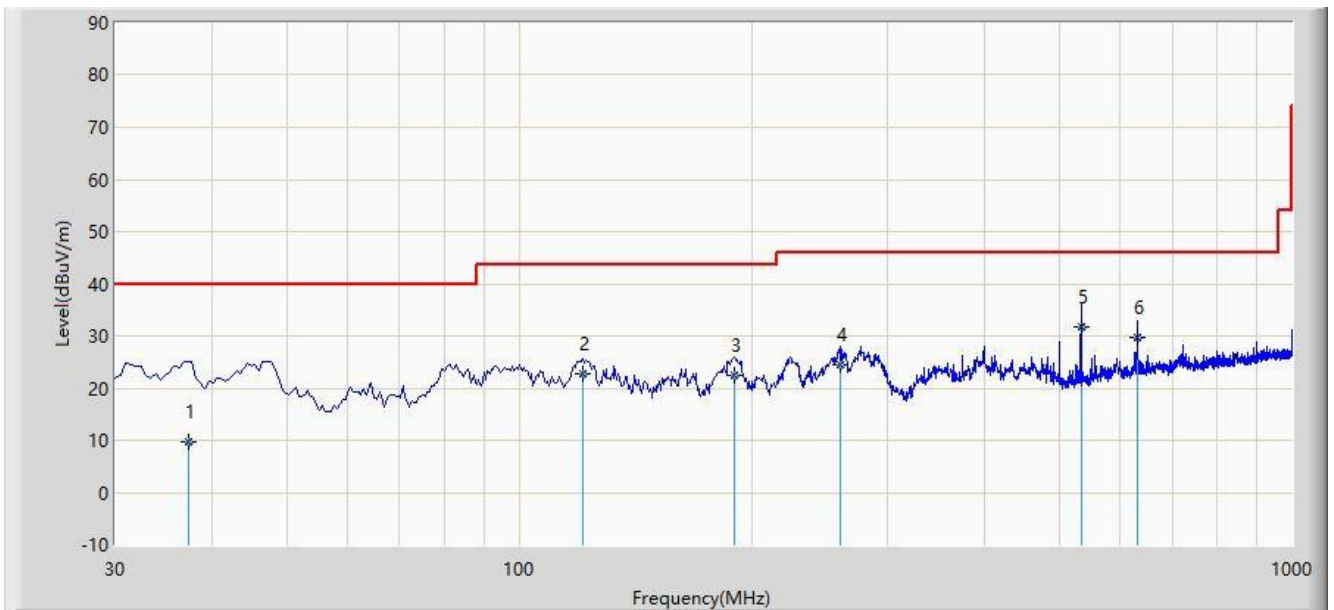

No	Flag	Mark	Frequency (MHz)	Measure Level (dBuV/m)	Reading Level (dBuV)	Over Limit (dB)	Limit (dBuV/m)	Factor	Type
1			37.275	9.818	-3.882	-30.182	40.000	13.700	QP
2			120.695	22.863	10.593	-20.637	43.500	12.270	QP
3			189.565	22.497	11.963	-21.003	43.500	10.534	QP
4			259.890	24.461	12.690	-21.539	46.000	11.771	QP
5		*	533.430	31.844	14.739	-14.156	46.000	17.105	QP
6			631.400	29.640	10.763	-16.360	46.000	18.877	QP

Note 1: Measure Level (dB $\mu$ V/m) = Reading Level (dB $\mu$ V) + Factor (dB)

Factor (dB) = Cable Loss (dB) + Antenna Factor (dB/m)

Note 2: The test trace is same as the ambient noise and the amplitude of the emissions are attenuated more than 20dB below the permissible (the test frequency range: 9kHz ~ 30MHz, 18GHz ~ 25GHz), therefore no data appear in the report.



## 7.8. Radiated Restricted Band Edge Measurement

### 7.8.1. Test Limit

#### For 15.205 requirement:

Radiated emissions which fall in the restricted bands, as defined in Section 15.205(a) of FCC part 15, must also comply with the radiated emission limits specified in Section 15.209(a).

Frequency (MHz)	Frequency (MHz)	Frequency (MHz)	Frequency (GHz)
0.090 - 0.110	16.42 - 16.423	399.9 - 410	4.5 - 5.15
<sup>1</sup> 0.495 - 0.505	16.69475 - 16.69525	608 - 614	5.35 - 5.46
2.1735 - 2.1905	16.80425 - 16.80475	960 - 1240	7.25 - 7.75
4.125 - 4.128	25.5 - 25.67	1300 - 1427	8.25 - 8.5
4.17725 - 4.17775	37.5 - 38.25	1435 - 1626.5	9.0 - 9.2
4.20725 - 4.20775	73 - 74.6	1645.5 - 1646.5	9.3 - 9.5
6.215 - 6.218	74.8 - 75.2	1660 - 1710	10.6 - 12.7
6.26775 - 6.26825	108 - 121.94	1718.8 - 1722.2	13.25 - 13.4
6.31175 - 6.31225	123 - 138	2200 - 2300	14.47 - 14.5
8.291 - 8.294	149.9 - 150.05	2310 - 2390	15.35 - 16.2
8.362 - 8.366	156.52475 - 156.525	2483.5 - 2500	17.7 - 21.4
8.37625 - 8.38675	156.7 - 156.9	2690 - 2900	22.01 - 23.12
8.41425 - 8.41475	162.0125 - 167.17	3260 - 3267	23.6 - 24.0
12.29 - 12.293	167.72 - 173.2	3332 - 3339	31.2 - 31.8
12.51975 - 12.52025	240 - 285	3345.8 - 3358	36.43 - 36.5
12.57675 - 12.57725	322 - 335.4	3600 - 4400	( <sup>2</sup> )
13.36 - 13.41	--	--	--

All out of band emissions appearing in a restricted band as specified in Section 15.205 of the Title 47CFR must not exceed the limits shown in Table per Section 15.209.

FCC Part 15 Subpart C Paragraph 15.209		
Frequency [MHz]	Field Strength [ $\mu\text{V}/\text{m}$ ]	Measured Distance [Meters]
0.009 ~ 0.490	2400/F (kHz)	300
0.490 ~ 1.705	24000/F (kHz)	30
1.705 ~ 30	30	30
30 ~ 88	100	3
88 ~ 216	150	3
216 ~ 960	200	3
Above 960	500	3

**For RSS-Gen Section 8.10 requirement:**

Radiated emissions which fall in the restricted bands, as defined in Section 8.10 of RSS-Gen, must also comply with the radiated emission limits specified in Section 8.9.

Frequency (MHz)	Frequency (MHz)	Frequency (MHz)
0.009 - 0.110	240 - 285	9.0 - 9.2
2.1735 - 2.1905	322 - 335.4	9.3 - 9.5
3.020 - 3.026	399.9 - 410	10.6 - 12.7
4.125 - 4.128	608 - 614	13.25 - 13.4
4.17725 - 4.17775	960 - 1427	14.47 - 14.5
4.20725 - 4.20775	1435 - 1626.5	15.35 - 16.2
5.677 - 5.683	1645.5 - 1646.5	17.7 - 21.4
6.215 - 6.218	1660 - 1710	22.01 - 23.12
6.26775 - 6.26825	1718.8 - 1722.2	23.6 - 24.0
6.31175 - 6.31225	2200 - 2300	31.2 - 31.8
8.291 - 8.294	2310 - 2390	36.43 - 36.5
8.362 - 8.366	2655 - 2900	Above 38.6
8.37625 - 8.38675	3260 - 3267	
8.41425 - 8.41475	3332 - 3339	
12.29 - 12.293	334.5 - 3358	
12.51975 - 12.52025	3500 - 4400	
12.57675 - 12.57725	4500 - 5150	
13.36 - 13.41	5350 - 5460	
16.42 - 16.423	7250 - 7750	
16.69475 - 16.69525	8025 - 8500	
16.80425 - 16.80475		
25.5 - 25.67		
37.5 - 38.25		
73 - 74.6		
74.8 - 75.2	--	
108 - 138		
156.52475 - 156.525225		
156.7 - 156.9		

Note: \*Certain frequency bands listed in Table 6 and in bands above 38.6 GHz are designated for licence-exempt applications. These frequency bands and the requirements that apply to the devices

are set out in the 200- and 300-series of RSSs, such as RSS-210 and RSS-310, which contain the requirements that apply to licence-exempt radio apparatus.

All out of band emissions appearing in a restricted band as specified in Section 8.10 of the RSS-Gen must not exceed the limits shown in Table per Section 8.9.

RSS-Gen Section 8.9		
Frequency [MHz]	Field Strength [ $\mu\text{V}/\text{m}$ ]	Measured Distance [Meters]
0.009 ~ 0.490	2400/F (kHz)	300
0.490 ~ 1.705	24000/F (kHz)	30
1.705 ~ 30	30	30
30 ~ 88	100	3
88 ~ 216	150	3
216 ~ 960	200	3
Above 960	500	3

### 7.8.2. Test Procedure Used

ANSI C63.10 Section 6.3 (General Requirements)

ANSI C63.10 Section 6.6 (Standard test method above 1GHz)

### 7.8.3. Test Setting

#### Peak Field Strength Measurements

1. Analyzer center frequency was set to the frequency of the radiated spurious emission of interest
2. RBW = as specified in Table 1
3. VBW = 3MHz
4. Detector = peak
5. Sweep time = auto couple
6. Trace mode = max hold
7. Trace was allowed to stabilize

### Average Field Strength Measurements

1. Analyzer center frequency was set to the frequency of the radiated spurious emission of interest
2. RBW = 1MHz
3. VBW  $\geq 1/T$
4. De As an alternative, the instrument may be set to linear detector mode. Ensure that video filtering is applied in linear voltage domain (rather than in a log or dB domain). Some instruments require linear display mode in order to accomplish this. Others have a setting for Average-VBW Type, which can be set to "Voltage" regardless of the display mode
5. Detector = Peak
6. Sweep time = auto
7. Trace mode = max hold
8. Allow max hold to run for at least 50 times (1/duty cycle) traces

#### **7.8.4.Test Setup**

1GHz ~ 18GHz Test Setup:

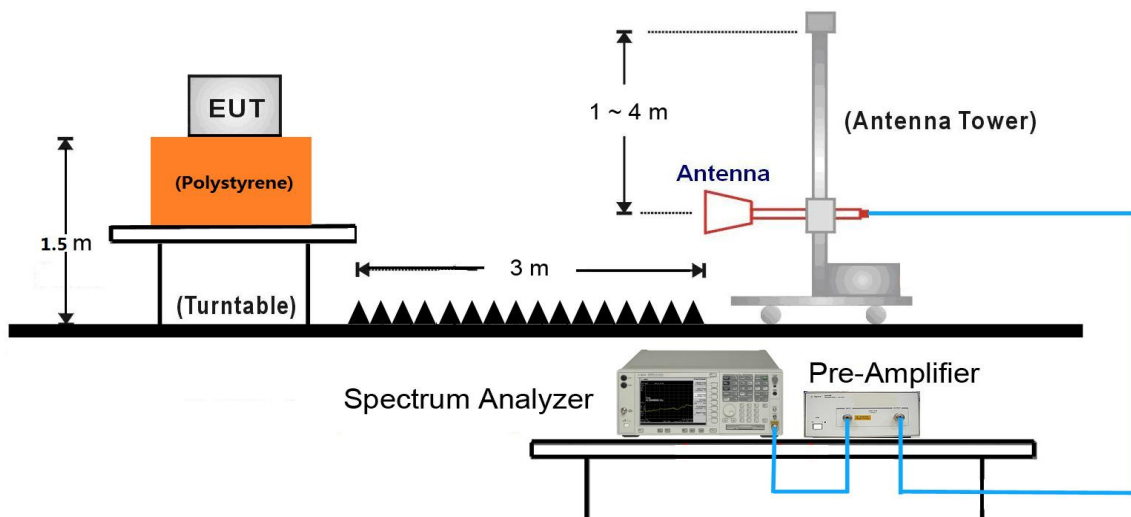

### 7.8.5. Test Result

Site: AC2	Time: 2018/01/13 - 11:50
Limit: FCC_Part15.209_RE(3m)	Engineer: Snake Ni
Probe: BBHA9120D_1-18GHz	Polarity: Horizontal
EUT: Speed Dome Camera (1080P WiFi PTZ)	Power: AC 120V/60Hz
Test Mode: Transmit by 802.11a at Channel 5180MHz	

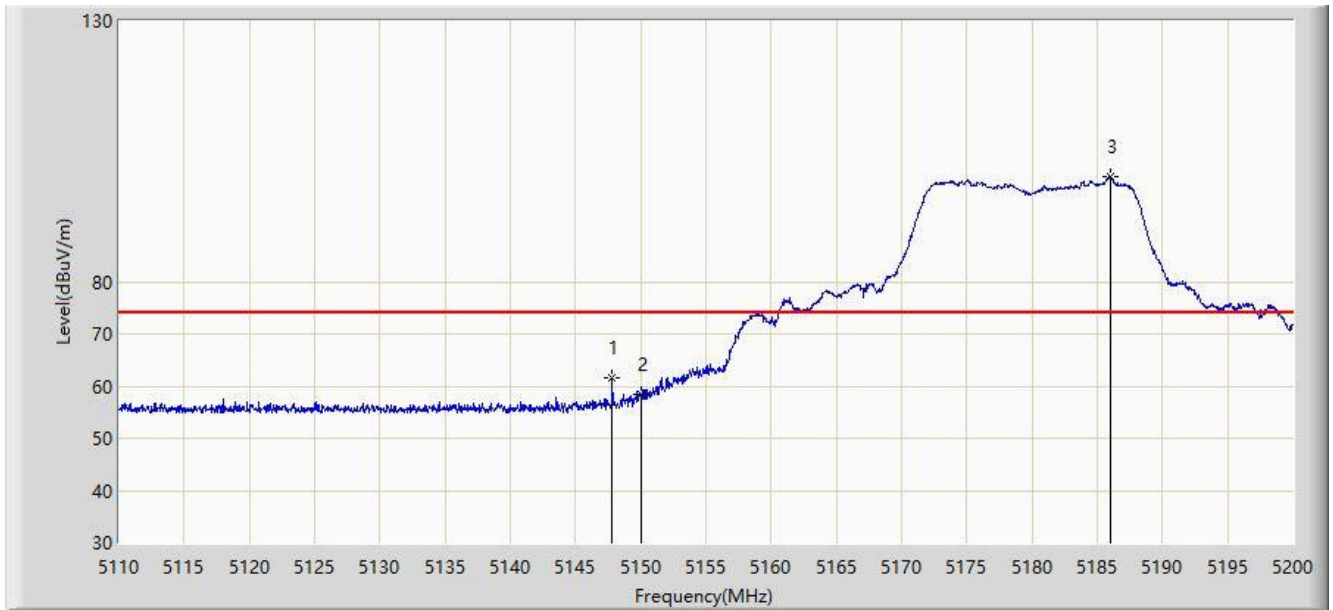

No	Flag	Mark	Frequency (MHz)	Measure Level (dBuV/m)	Reading Level (dBuV)	Over Limit (dB)	Limit (dBuV/m)	Factor (dB)	Type
1			5147.800	61.658	55.540	-12.342	74.000	6.118	PK
2			5150.000	58.332	52.209	-15.668	74.000	6.123	PK
3		*	5185.960	100.081	94.028	N/A	N/A	6.054	PK

Note: Measure Level (dBμV/m) = Reading Level (dBμV) + Factor (dB)

Factor (dB) = Cable Loss (dB) + Antenna Factor (dB/m) - Pre\_Amplifier Gain (dB)

Site: AC2	Time: 2018/01/13 - 11:52
Limit: FCC_Part15.209_RE(3m)	Engineer: Snake Ni
Probe: BBHA9120D_1-18GHz	Polarity: Horizontal
EUT: Speed Dome Camera (1080P WiFi PTZ)	Power: AC 120V/60Hz
Test Mode: Transmit by 802.11a at Channel 5180MHz	

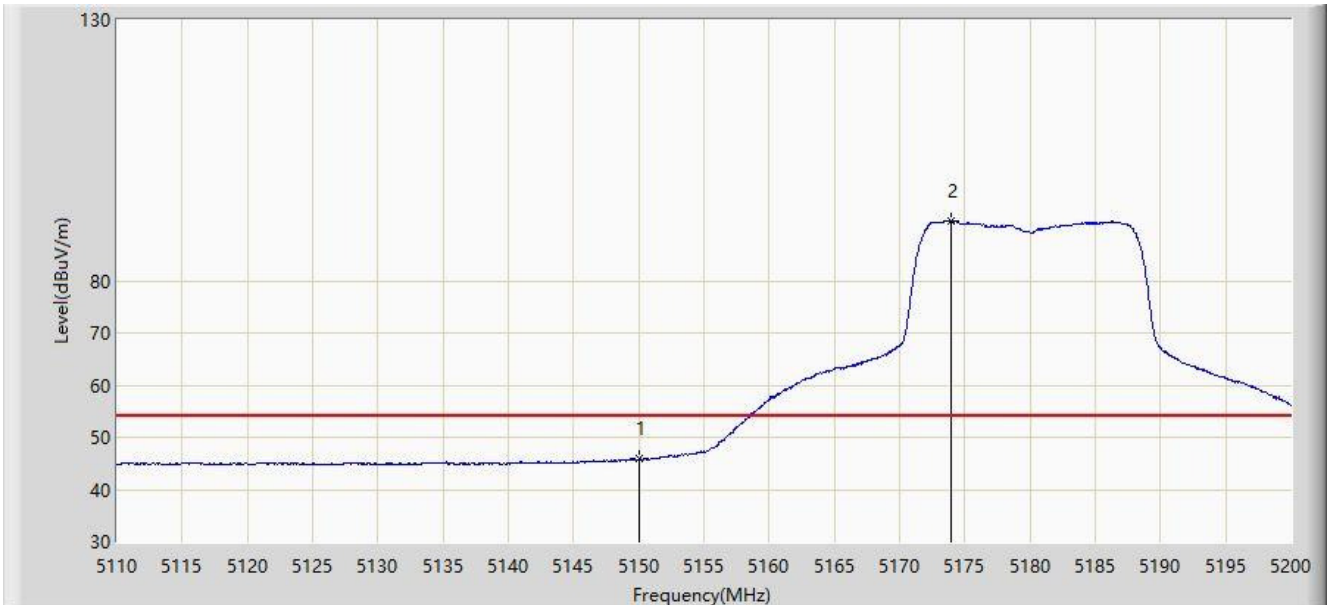

No	Flag	Mark	Frequency (MHz)	Measure Level (dBuV/m)	Reading Level (dBuV)	Over Limit (dB)	Limit (dBuV/m)	Factor (dB)	Type
1			5150.000	45.834	39.711	-8.166	54.000	6.123	AV
2		*	5173.900	91.474	85.367	N/A	N/A	6.107	AV

Note: Measure Level (dB $\mu$ V/m) = Reading Level (dB $\mu$ V) + Factor (dB)

Factor (dB) = Cable Loss (dB) + Antenna Factor (dB/m) - Pre\_Amplifier Gain (dB)

Site: AC2	Time: 2018/01/13 - 11:53
Limit: FCC_Part15.209_RE(3m)	Engineer: Snake Ni
Probe: BBHA9120D_1-18GHz	Polarity: Vertical
EUT: Speed Dome Camera (1080P WiFi PTZ)	Power: AC 120V/60Hz
Test Mode: Transmit by 802.11a at Channel 5180MHz	

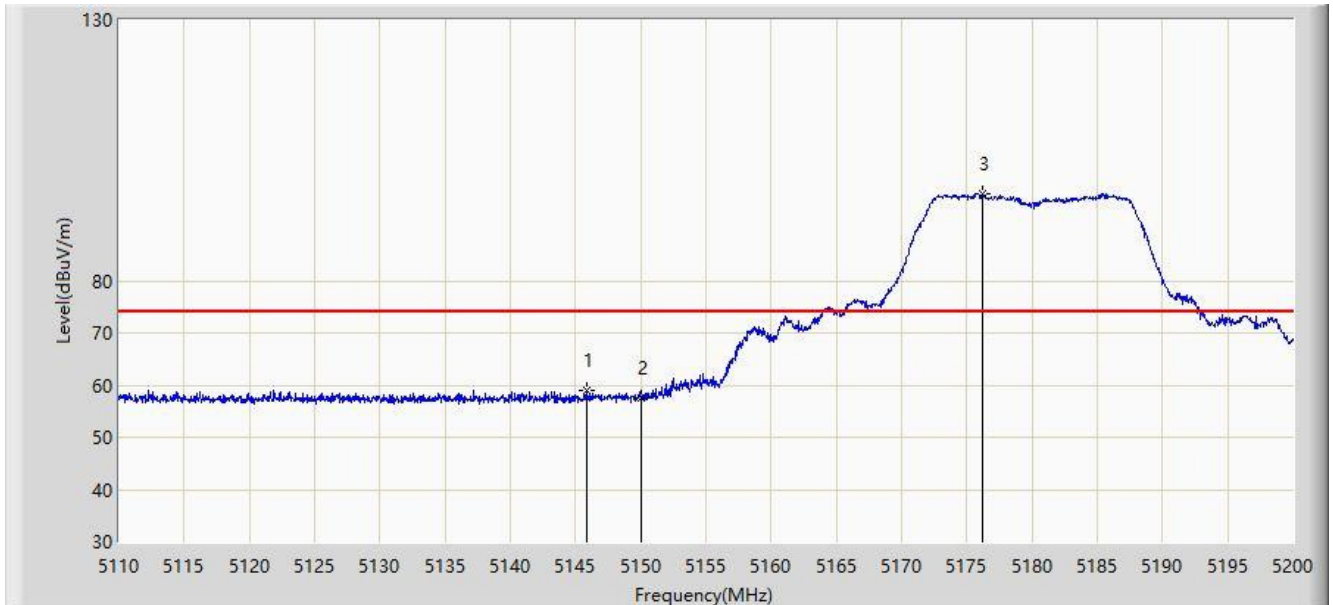

No	Flag	Mark	Frequency (MHz)	Measure Level (dBuV/m)	Reading Level (dBuV)	Over Limit (dB)	Limit (dBuV/m)	Factor (dB)	Type
1			5145.820	58.853	52.740	-15.147	74.000	6.113	PK
2			5150.000	57.537	51.414	-16.463	74.000	6.123	PK
3		*	5176.150	96.668	90.567	N/A	N/A	6.101	PK

Note: Measure Level (dBμV/m) = Reading Level (dBμV) + Factor (dB)

Factor (dB) = Cable Loss (dB) + Antenna Factor (dB/m) - Pre\_Amplifier Gain (dB)



Site: AC2	Time: 2018/01/13 - 11:55
Limit: FCC_Part15.209_RE(3m)	Engineer: Snake Ni
Probe: BBHA9120D_1-18GHz	Polarity: Vertical
EUT: Speed Dome Camera (1080P WiFi PTZ)	Power: AC 120V/60Hz
Test Mode: Transmit by 802.11a at Channel 5180MHz	

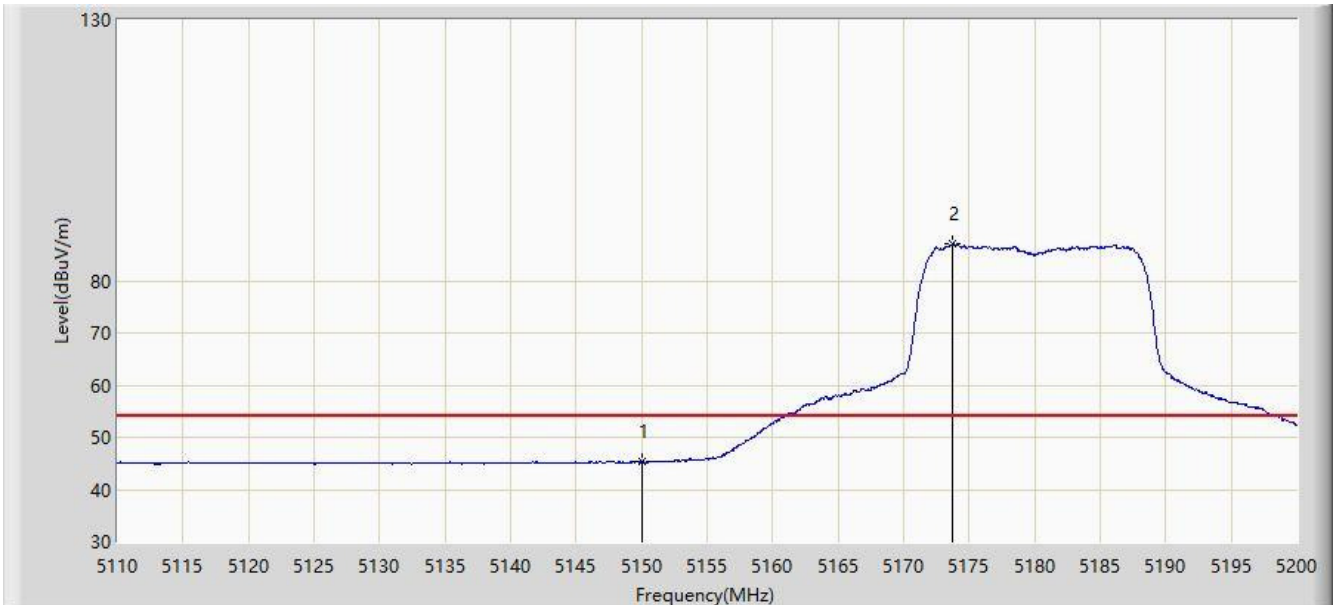

No	Flag	Mark	Frequency (MHz)	Measure Level (dBuV/m)	Reading Level (dBuV)	Over Limit (dB)	Limit (dBuV/m)	Factor (dB)	Type
1			5150.000	45.236	39.113	-8.764	54.000	6.123	AV
2		*	5173.675	87.031	80.923	N/A	N/A	6.108	AV

Note: Measure Level (dB $\mu$ V/m) = Reading Level (dB $\mu$ V) + Factor (dB)

Factor (dB) = Cable Loss (dB) + Antenna Factor (dB/m) - Pre\_Amplifier Gain (dB)

Site: AC2	Time: 2018/01/13 - 11:57
Limit: FCC_Part15.407_RE(3m)_Bandedge	Engineer: Snake Ni
Probe: BBHA9120D_1-18GHz	Polarity: Horizontal
EUT: Speed Dome Camera (1080P WiFi PTZ)	Power: AC 120V/60Hz
Test Mode: Transmit by 802.11a at Channel 5745MHz	

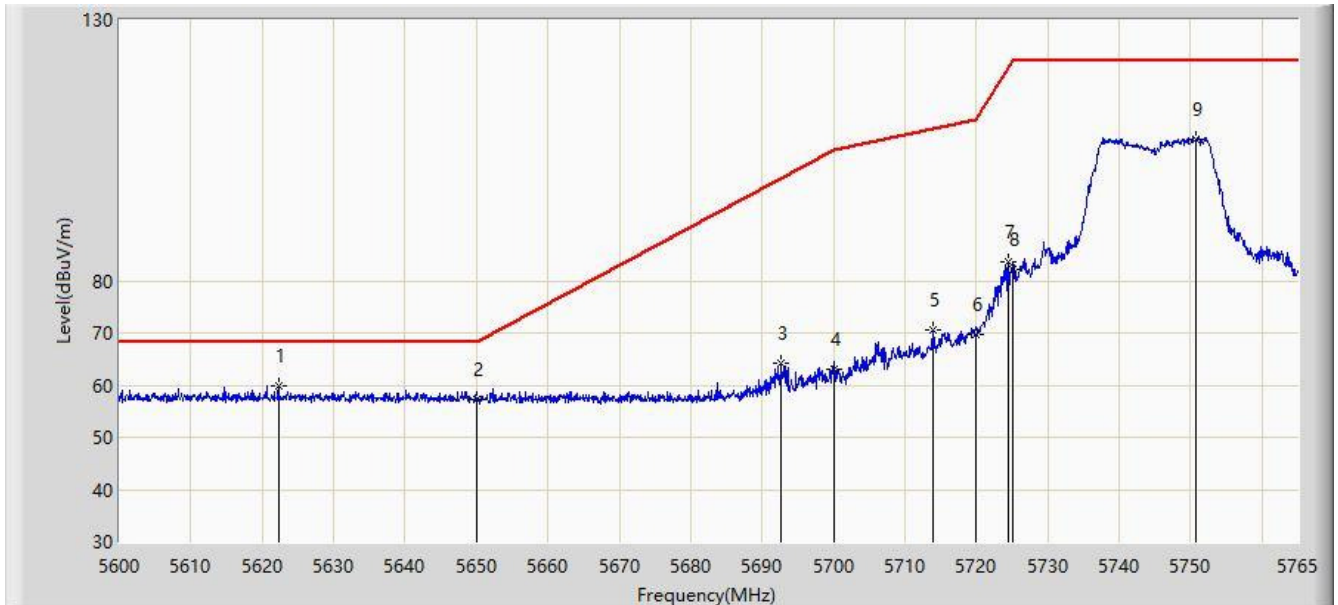

No	Flag	Mark	Frequency (MHz)	Measure Level (dBuV/m)	Reading Level (dBuV)	Over Limit (dB)	Limit (dBuV/m)	Factor (dB)	Type
1		*	5622.275	59.909	53.132	-8.291	68.200	6.778	PK
2			5650.000	57.267	50.284	-10.933	68.200	6.983	PK
3			5692.730	64.064	57.096	-35.777	99.840	6.968	PK
4			5700.000	63.093	56.115	-42.107	105.200	6.978	PK
5			5714.015	70.493	63.440	-38.633	109.126	7.053	PK
6			5720.000	69.566	62.452	-41.234	110.800	7.114	PK
7			5724.493	83.662	76.502	-37.382	121.044	7.161	PK
8			5725.000	82.120	74.955	-40.080	122.200	7.165	PK
9			5750.645	107.180	99.788	N/A	N/A	7.392	PK

Note: Measure Level (dBμV/m) = Reading Level (dBμV) + Factor (dB)

Factor (dB) = Cable Loss (dB) + Antenna Factor (dB/m) - Pre\_Amplifier Gain (dB)

Site: AC2	Time: 2018/01/13 - 11:59
Limit: FCC_Part15.407_RE(3m)_Bandedge	Engineer: Snake Ni
Probe: BBHA9120D_1-18GHz	Polarity: Vertical
EUT: Speed Dome Camera (1080P WiFi PTZ)	Power: AC 120V/60Hz
Test Mode: Transmit by 802.11a at Channel 5745MHz	

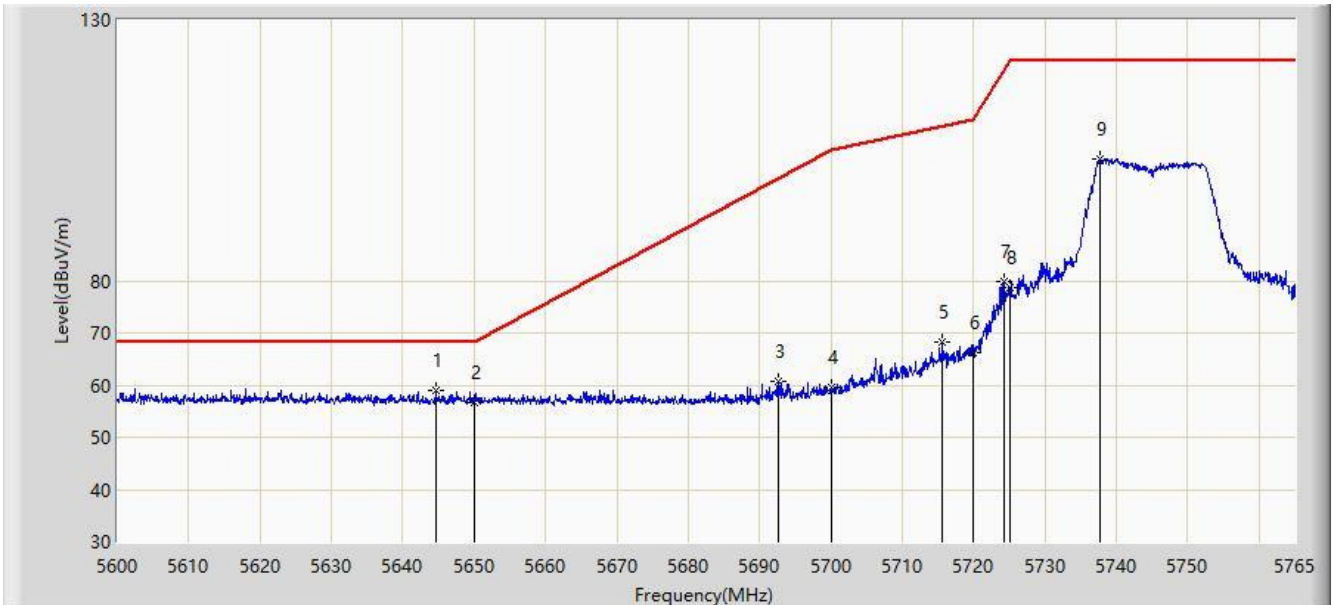

No	Flag	Mark	Frequency (MHz)	Measure Level (dBuV/m)	Reading Level (dBuV)	Over Limit (dB)	Limit (dBuV/m)	Factor (dB)	Type
1		*	5644.632	58.914	51.961	-9.286	68.200	6.953	PK
2			5650.000	56.619	49.636	-11.581	68.200	6.983	PK
3			5692.647	60.853	53.886	-38.926	99.779	6.968	PK
4			5700.000	59.477	52.499	-45.723	105.200	6.978	PK
5			5715.665	68.177	61.107	-41.411	109.588	7.069	PK
6			5720.000	66.111	58.997	-44.689	110.800	7.114	PK
7			5724.245	79.992	72.834	-40.487	120.479	7.158	PK
8			5725.000	78.716	71.551	-43.484	122.200	7.165	PK
9			5737.775	103.284	95.994	N/A	N/A	7.291	PK

Note: Measure Level (dBμV/m) = Reading Level (dBμV) + Factor (dB)

Factor (dB) = Cable Loss (dB) + Antenna Factor (dB/m) - Pre\_Amplifier Gain (dB)

Site: AC2	Time: 2018/01/13 - 12:00
Limit: FCC_Part15.407_RE(3m)_Bandedge	Engineer: Snake Ni
Probe: BBHA9120D_1-18GHz	Polarity: Horizontal
EUT: Speed Dome Camera (1080P WiFi PTZ)	Power: AC 120V/60Hz
Test Mode: Transmit by 802.11a at Channel 5825MHz	

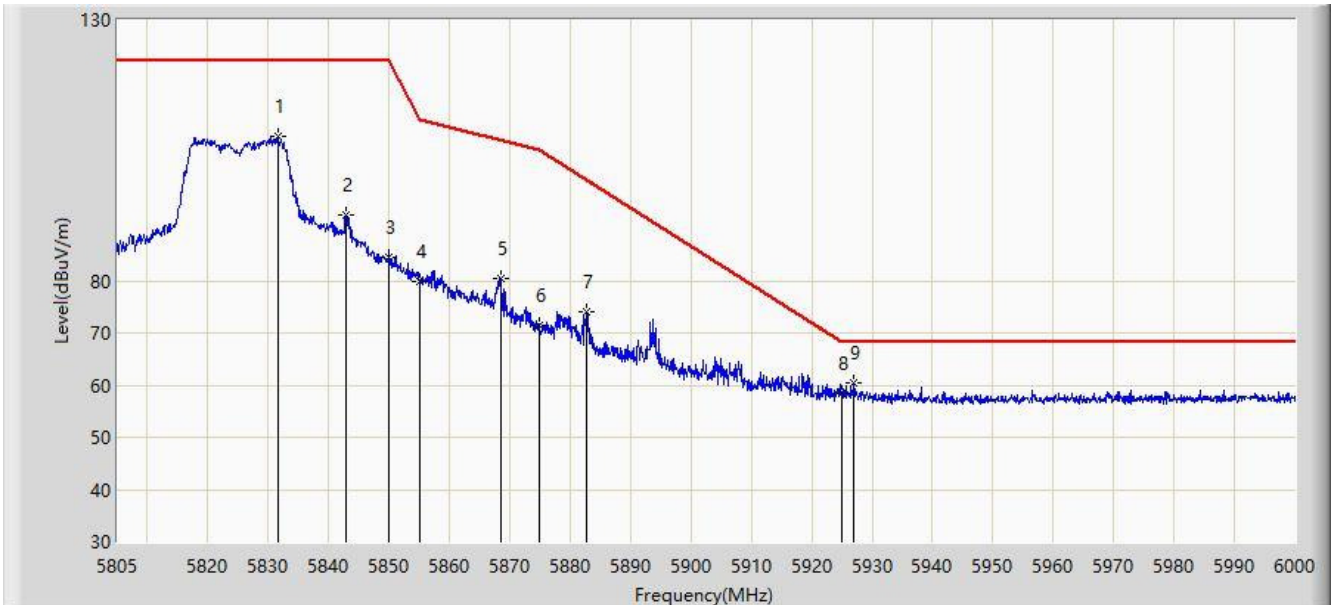

No	Flag	Mark	Frequency (MHz)	Measure Level (dBuV/m)	Reading Level (dBuV)	Over Limit (dB)	Limit (dBuV/m)	Factor (dB)	Type
1			5831.520	107.643	99.846	N/A	N/A	7.797	PK
2			5842.830	92.642	84.765	-29.558	122.200	7.877	PK
3			5850.000	84.627	76.728	-37.573	122.200	7.899	PK
4			5855.000	79.760	71.854	-31.040	110.800	7.905	PK
5			5868.473	80.485	72.573	-26.540	107.025	7.911	PK
6			5875.000	71.491	63.583	-33.709	105.200	7.909	PK
7			5882.805	74.090	66.182	-25.314	99.404	7.908	PK
8			5925.000	58.350	50.317	-9.850	68.200	8.033	PK
9		*	5926.973	60.523	52.476	-7.677	68.200	8.046	PK

Note: Measure Level (dBuV/m) = Reading Level (dBuV) + Factor (dB)

Factor (dB) = Cable Loss (dB) + Antenna Factor (dB/m) - Pre\_Amplifier Gain (dB)

Site: AC2	Time: 2018/01/13 - 12:02
Limit: FCC_Part15.407_RE(3m)_Bandedge	Engineer: Snake Ni
Probe: BBHA9120D_1-18GHz	Polarity: Vertical
EUT: Speed Dome Camera (1080P WiFi PTZ)	Power: AC 120V/60Hz
Test Mode: Transmit by 802.11a at Channel 5825MHz	

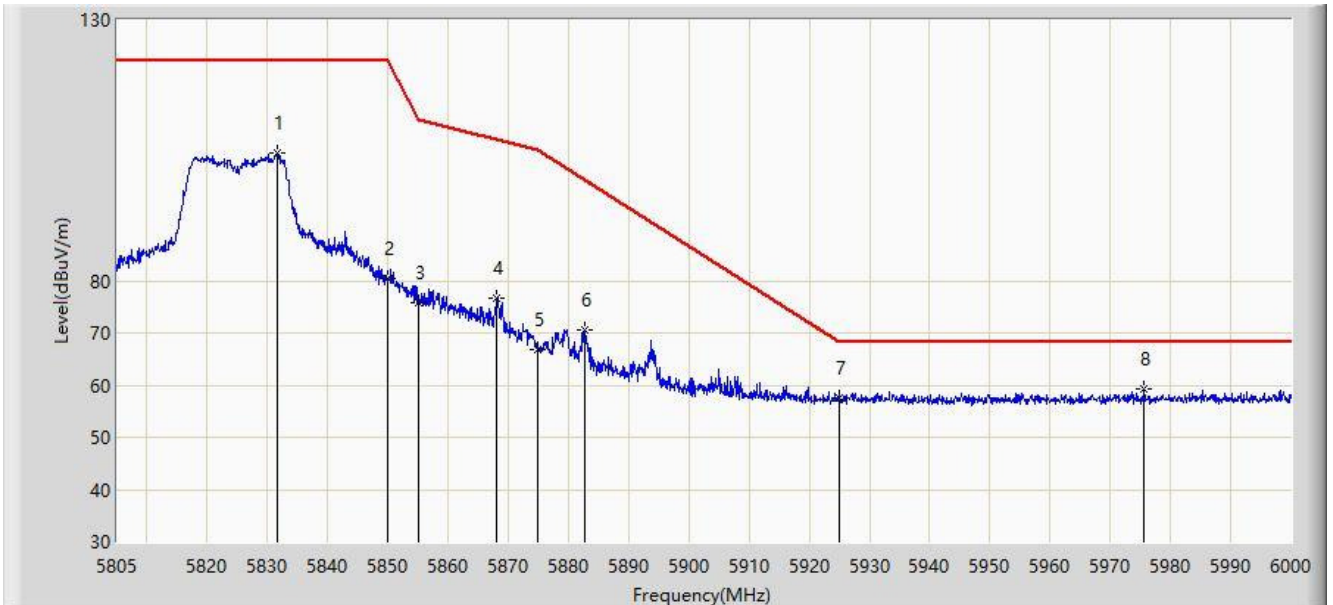

No	Flag	Mark	Frequency (MHz)	Measure Level (dBuV/m)	Reading Level (dBuV)	Over Limit (dB)	Limit (dBuV/m)	Factor (dB)	Type
1			5831.618	104.596	96.798	N/A	N/A	7.798	PK
2			5850.000	80.425	72.526	-41.775	122.200	7.899	PK
3			5855.000	75.850	67.944	-34.950	110.800	7.905	PK
4			5868.083	76.804	68.892	-30.330	107.135	7.912	PK
5			5875.000	66.858	58.950	-38.342	105.200	7.909	PK
6			5882.805	70.454	62.546	-28.950	99.404	7.908	PK
7			5925.000	57.538	49.505	-10.662	68.200	8.033	PK
8		*	5975.625	59.248	51.173	-8.952	68.200	8.075	PK

Note: Measure Level (dBuV/m) = Reading Level (dBuV) + Factor (dB)

Factor (dB) = Cable Loss (dB) + Antenna Factor (dB/m) - Pre\_Amplifier Gain (dB)

Site: AC2	Time: 2018/01/13 - 12:03
Limit: FCC_Part15.209_RE(3m)	Engineer: Snake Ni
Probe: BBHA9120D_1-18GHz	Polarity: Horizontal
EUT: Speed Dome Camera (1080P WiFi PTZ)	Power: AC 120V/60Hz
Test Mode: Transmit by 802.11n-HT20 at Channel 5180MHz	

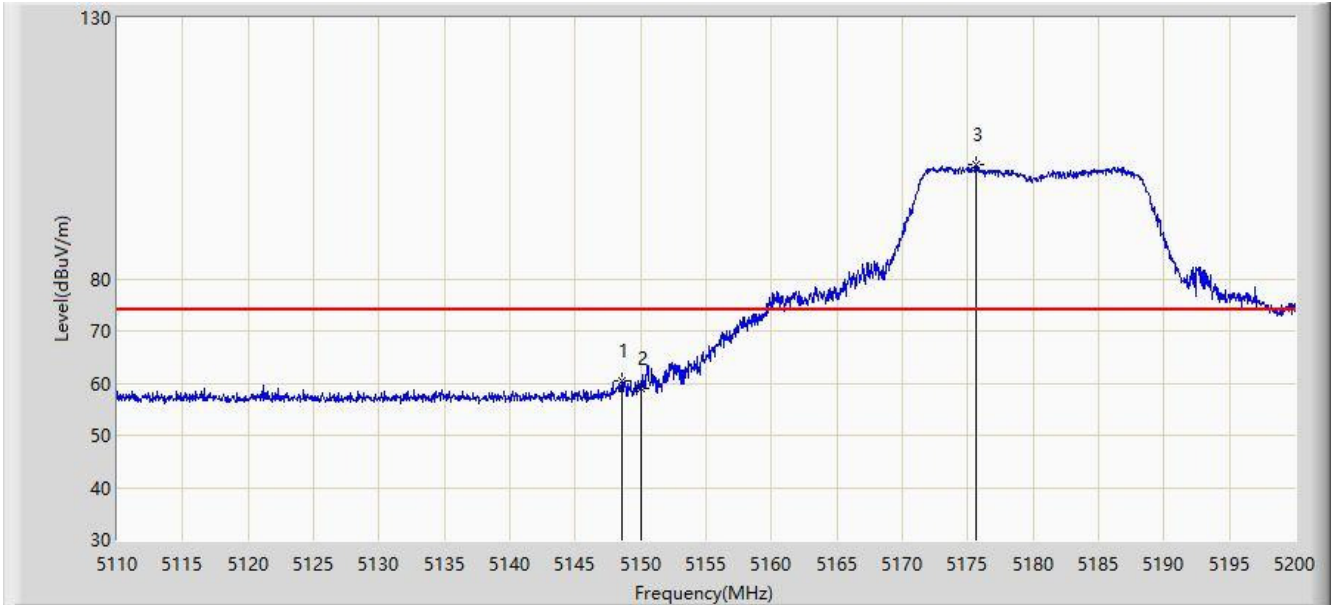

No	Flag	Mark	Frequency (MHz)	Measure Level (dBuV/m)	Reading Level (dBuV)	Over Limit (dB)	Limit (dBuV/m)	Factor (dB)	Type
1			5148.610	60.478	54.358	-13.522	74.000	6.121	PK
2			5150.000	58.903	52.780	-15.097	74.000	6.123	PK
3		*	5175.655	101.949	95.846	N/A	N/A	6.102	PK

Note: Measure Level (dB $\mu$ V/m) = Reading Level (dB $\mu$ V) + Factor (dB)

Factor (dB) = Cable Loss (dB) + Antenna Factor (dB/m) - Pre\_Amplifier Gain (dB)

Site: AC2	Time: 2018/01/13 - 12:05
Limit: FCC_Part15.209_RE(3m)	Engineer: Snake Ni
Probe: BBHA9120D_1-18GHz	Polarity: Horizontal
EUT: Speed Dome Camera (1080P WiFi PTZ)	Power: AC 120V/60Hz
Test Mode: Transmit by 802.11n-HT20 at Channel 5180MHz	

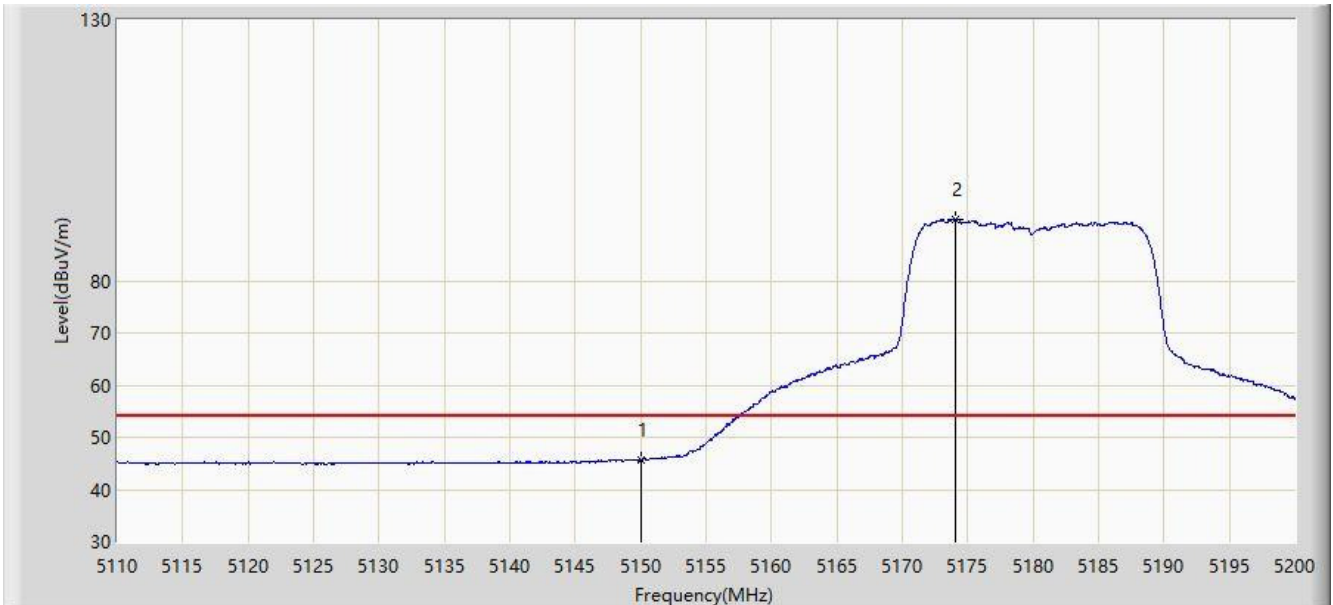

No	Flag	Mark	Frequency (MHz)	Measure Level (dBuV/m)	Reading Level (dBuV)	Over Limit (dB)	Limit (dBuV/m)	Factor (dB)	Type
1			5150.000	45.647	39.524	-8.353	54.000	6.123	AV
2		*	5174.080	91.805	85.698	N/A	N/A	6.106	AV

Note: Measure Level (dB $\mu$ V/m) = Reading Level (dB $\mu$ V) + Factor (dB)

Factor (dB) = Cable Loss (dB) + Antenna Factor (dB/m) - Pre\_Amplifier Gain (dB)

Site: AC2	Time: 2018/01/13 - 12:06
Limit: FCC_Part15.209_RE(3m)	Engineer: Snake Ni
Probe: BBHA9120D_1-18GHz	Polarity: Vertical
EUT: Speed Dome Camera (1080P WiFi PTZ)	Power: AC 120V/60Hz
Test Mode: Transmit by 802.11n-HT20 at Channel 5180MHz	

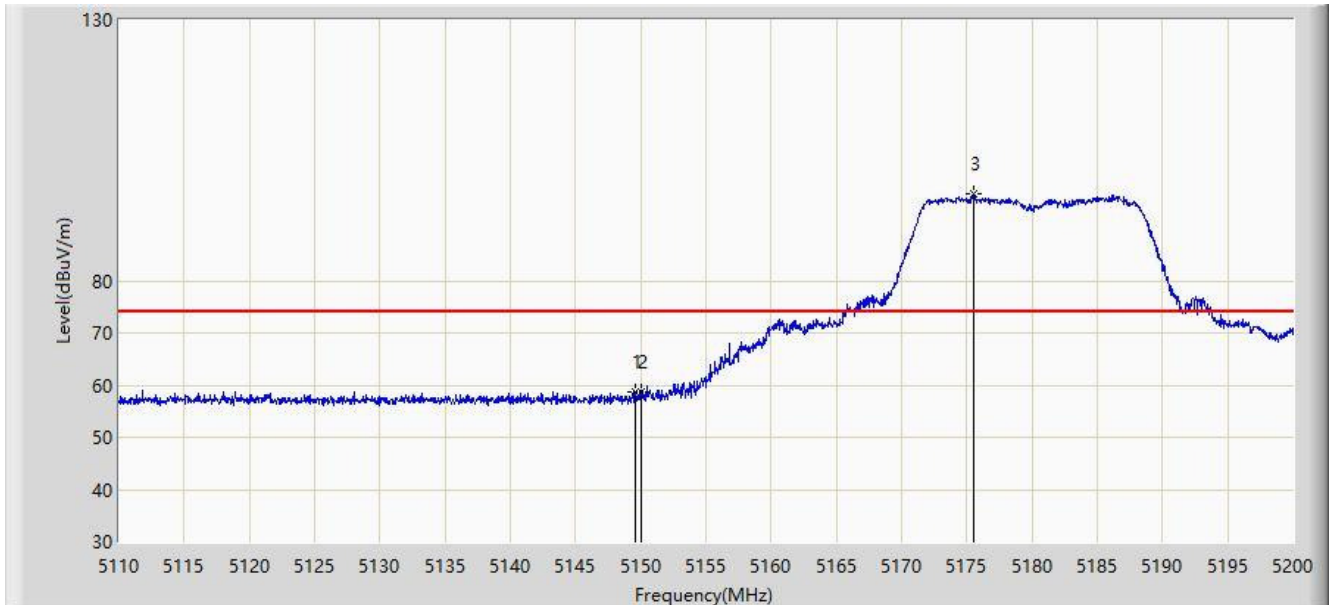

No	Flag	Mark	Frequency (MHz)	Measure Level (dBuV/m)	Reading Level (dBuV)	Over Limit (dB)	Limit (dBuV/m)	Factor (dB)	Type
1			5149.600	58.821	52.699	-15.179	74.000	6.122	PK
2			5150.000	58.678	52.555	-15.322	74.000	6.123	PK
3		*	5175.475	96.675	90.572	N/A	N/A	6.103	PK

Note: Measure Level (dB $\mu$ V/m) = Reading Level (dB $\mu$ V) + Factor (dB)

Factor (dB) = Cable Loss (dB) + Antenna Factor (dB/m) - Pre\_Amplifier Gain (dB)



Site: AC2	Time: 2018/01/13 - 12:07
Limit: FCC_Part15.209_RE(3m)	Engineer: Snake Ni
Probe: BBHA9120D_1-18GHz	Polarity: Vertical
EUT: Speed Dome Camera (1080P WiFi PTZ)	Power: AC 120V/60Hz
Test Mode: Transmit by 802.11n-HT20 at Channel 5180MHz	

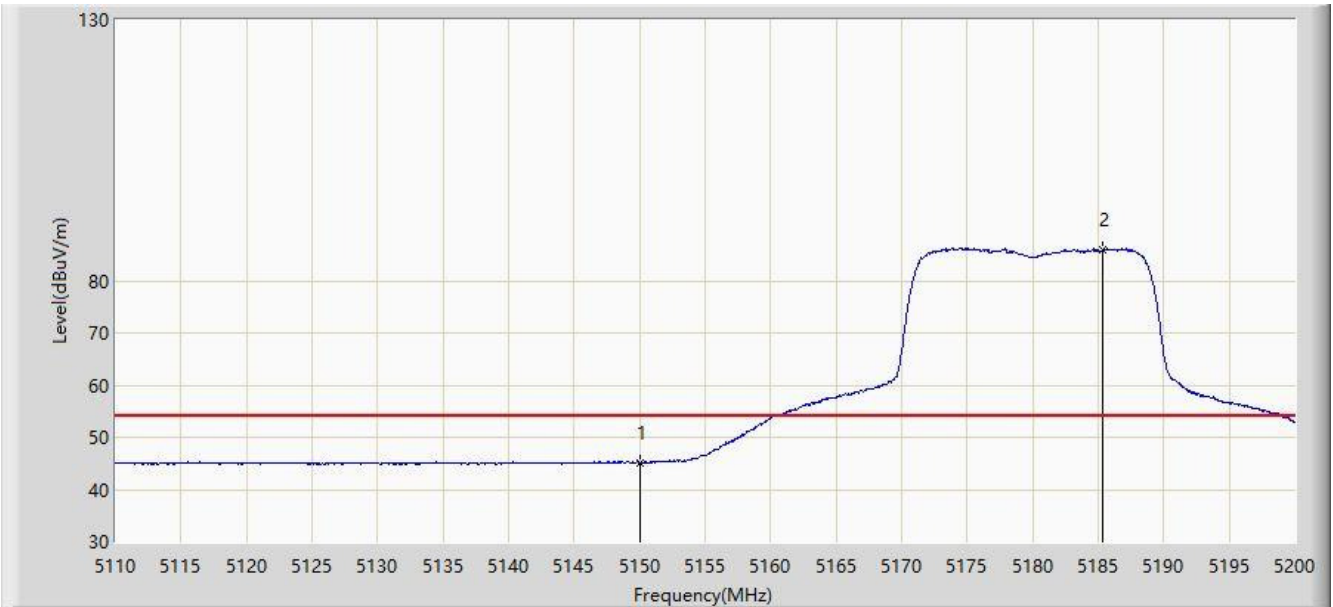

No	Flag	Mark	Frequency (MHz)	Measure Level (dBuV/m)	Reading Level (dBuV)	Over Limit (dB)	Limit (dBuV/m)	Factor (dB)	Type
1			5150.000	45.208	39.085	-8.792	54.000	6.123	AV
2		*	5185.375	86.065	80.007	N/A	N/A	6.059	AV

Note: Measure Level (dBμV/m) = Reading Level (dBμV) + Factor (dB)

Factor (dB) = Cable Loss (dB) + Antenna Factor (dB/m) - Pre\_Amplifier Gain (dB)

Site: AC2	Time: 2018/01/13 - 12:08
Limit: FCC_Part15.407_RE(3m)_Bandedge	Engineer: Snake Ni
Probe: BBHA9120D_1-18GHz	Polarity: Horizontal
EUT: Speed Dome Camera (1080P WiFi PTZ)	Power: AC 120V/60Hz
Test Mode: Transmit by 802.11n-HT20 at Channel 5745MHz	

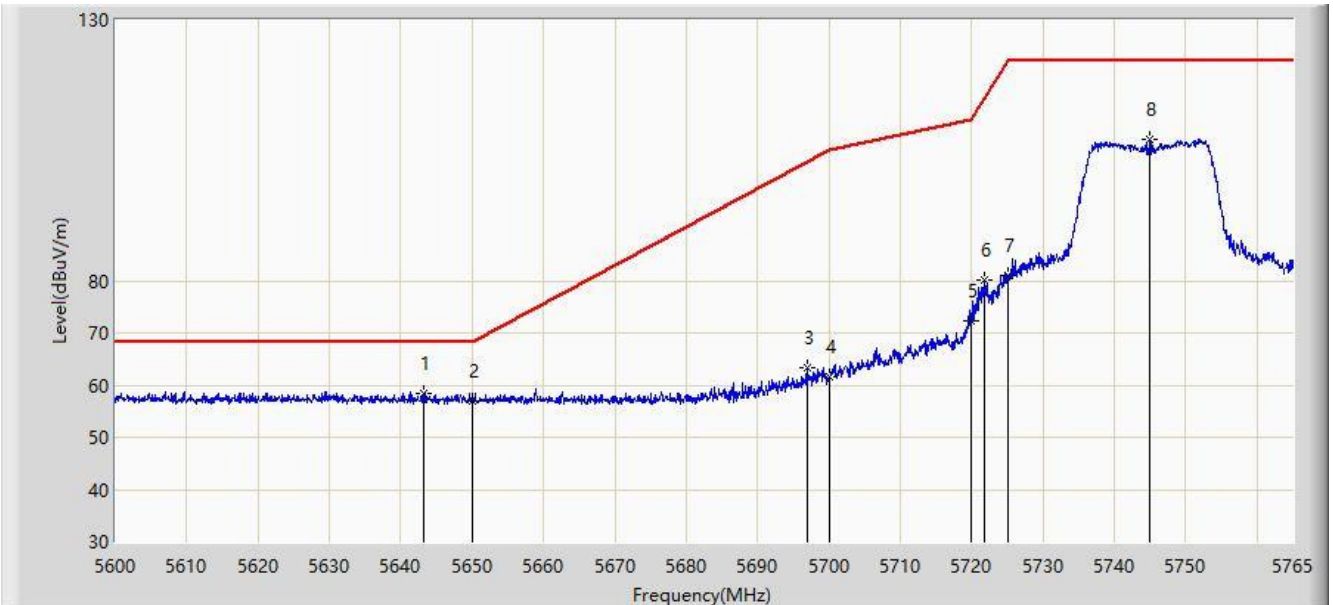

No	Flag	Mark	Frequency (MHz)	Measure Level (dBuV/m)	Reading Level (dBuV)	Over Limit (dB)	Limit (dBuV/m)	Factor (dB)	Type
1		*	5643.312	58.466	51.521	-9.734	68.200	6.945	PK
2			5650.000	57.054	50.071	-11.146	68.200	6.983	PK
3			5696.937	63.346	56.372	-39.597	102.943	6.974	PK
4			5700.000	61.461	54.483	-43.739	105.200	6.978	PK
5			5720.000	72.409	65.295	-38.391	110.800	7.114	PK
6			5721.687	80.219	73.087	-34.429	114.647	7.132	PK
7			5725.000	80.978	73.813	-41.222	122.200	7.165	PK
8			5745.035	107.006	99.653	N/A	N/A	7.353	PK

Note: Measure Level (dBuV/m) = Reading Level (dBuV) + Factor (dB)

Factor (dB) = Cable Loss (dB) + Antenna Factor (dB/m) - Pre\_Amplifier Gain (dB)

Site: AC2	Time: 2018/01/13 - 12:10
Limit: FCC_Part15.407_RE(3m)_Bandedge	Engineer: Snake Ni
Probe: BBHA9120D_1-18GHz	Polarity: Vertical
EUT: Speed Dome Camera (1080P WiFi PTZ)	Power: AC 120V/60Hz
Test Mode: Transmit by 802.11n-HT20 at Channel 5745MHz	

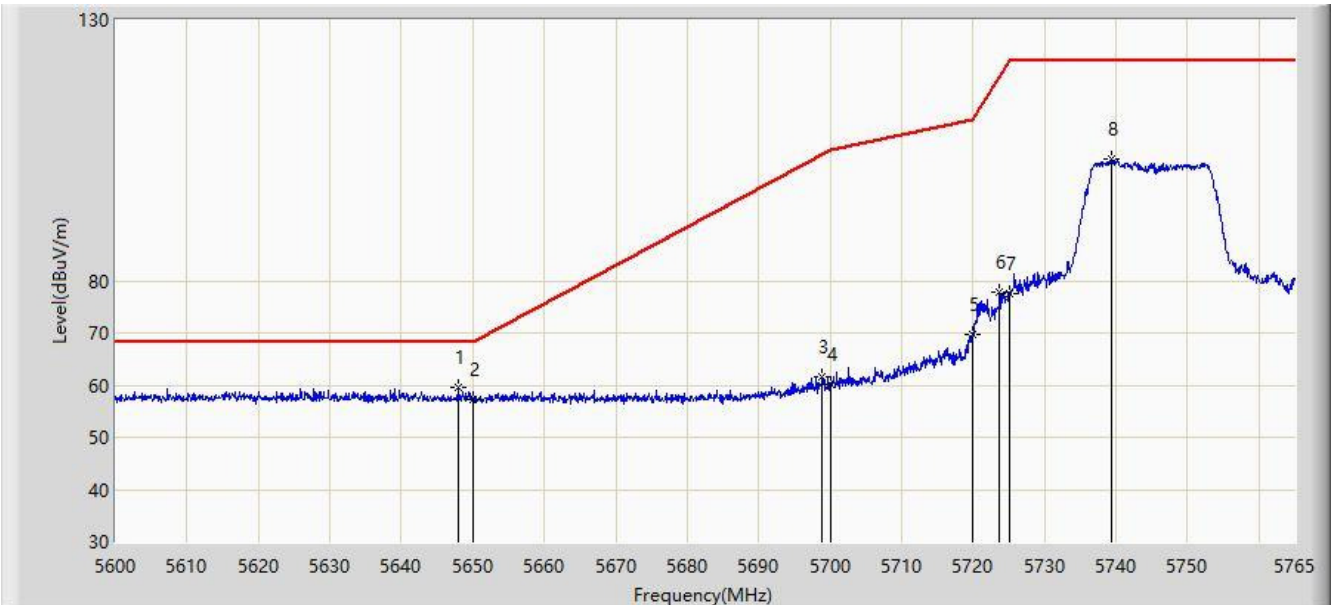

No	Flag	Mark	Frequency (MHz)	Measure Level (dBuV/m)	Reading Level (dBuV)	Over Limit (dB)	Limit (dBuV/m)	Factor (dB)	Type
1		*	5647.933	59.427	52.456	-8.773	68.200	6.972	PK
2			5650.000	57.314	50.331	-10.886	68.200	6.983	PK
3			5698.835	61.647	54.671	-42.694	104.342	6.977	PK
4			5700.000	60.246	53.268	-44.954	105.200	6.978	PK
5			5720.000	69.689	62.575	-41.111	110.800	7.114	PK
6			5723.667	77.750	70.598	-41.412	119.162	7.152	PK
7			5725.000	77.522	70.357	-44.678	122.200	7.165	PK
8			5739.425	103.251	95.945	N/A	N/A	7.306	PK

Note: Measure Level (dBuV/m) = Reading Level (dBuV) + Factor (dB)

Factor (dB) = Cable Loss (dB) + Antenna Factor (dB/m) - Pre\_Amplifier Gain (dB)

Site: AC2	Time: 2018/01/13 - 12:12
Limit: FCC_Part15.407_RE(3m)_Bandedge	Engineer: Snake Ni
Probe: BBHA9120D_1-18GHz	Polarity: Horizontal
EUT: Speed Dome Camera (1080P WiFi PTZ)	Power: AC 120V/60Hz
Test Mode: Transmit by 802.11n-HT20 at Channel 5825MHz	

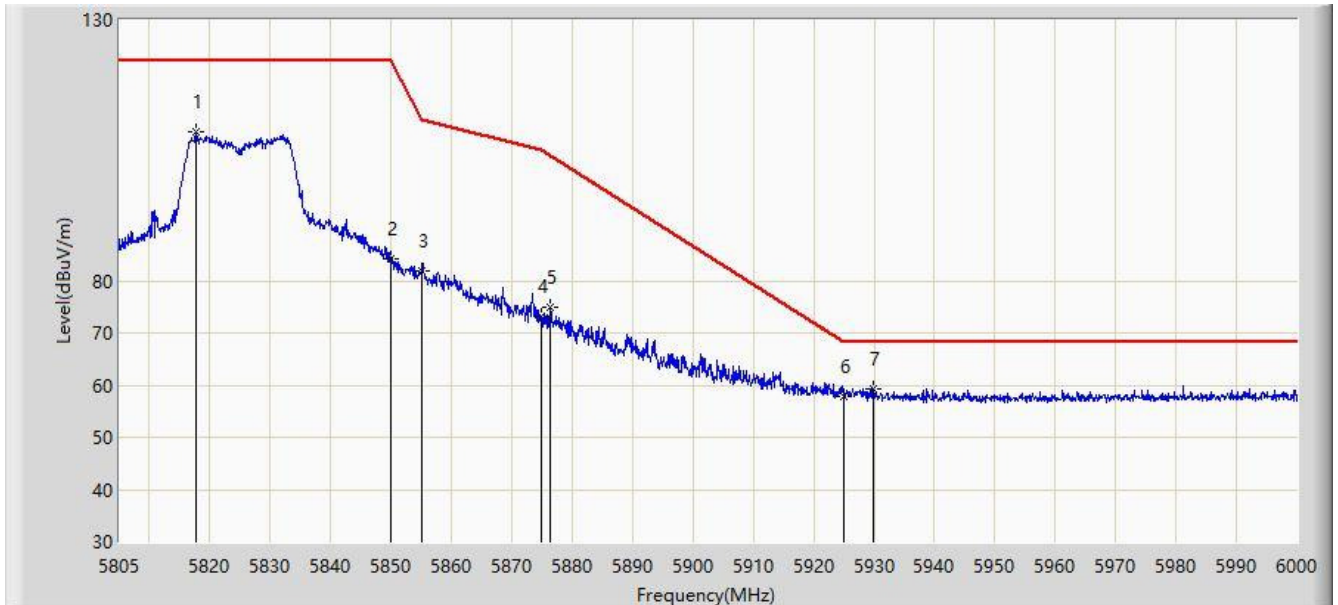

No	Flag	Mark	Frequency (MHz)	Measure Level (dBuV/m)	Reading Level (dBuV)	Over Limit (dB)	Limit (dBuV/m)	Factor (dB)	Type
1			5817.772	108.460	100.800	N/A	N/A	7.660	PK
2			5850.000	84.137	76.238	-38.063	122.200	7.899	PK
3			5855.000	81.876	73.970	-28.924	110.800	7.905	PK
4			5875.000	73.103	65.195	-32.097	105.200	7.909	PK
5			5876.272	74.921	67.013	-29.334	104.255	7.907	PK
6			5925.000	57.772	49.739	-10.428	68.200	8.033	PK
7		*	5929.897	59.396	51.329	-8.804	68.200	8.067	PK

Note: Measure Level (dBμV/m) = Reading Level (dBμV) + Factor (dB)

Factor (dB) = Cable Loss (dB) + Antenna Factor (dB/m) - Pre\_Amplifier Gain (dB)

Site: AC2	Time: 2018/01/13 - 12:14
Limit: FCC_Part15.407_RE(3m)_Bandedge	Engineer: Snake Ni
Probe: BBHA9120D_1-18GHz	Polarity: Vertical
EUT: Speed Dome Camera (1080P WiFi PTZ)	Power: AC 120V/60Hz
Test Mode: Transmit by 802.11n-HT20 at Channel 5825MHz	

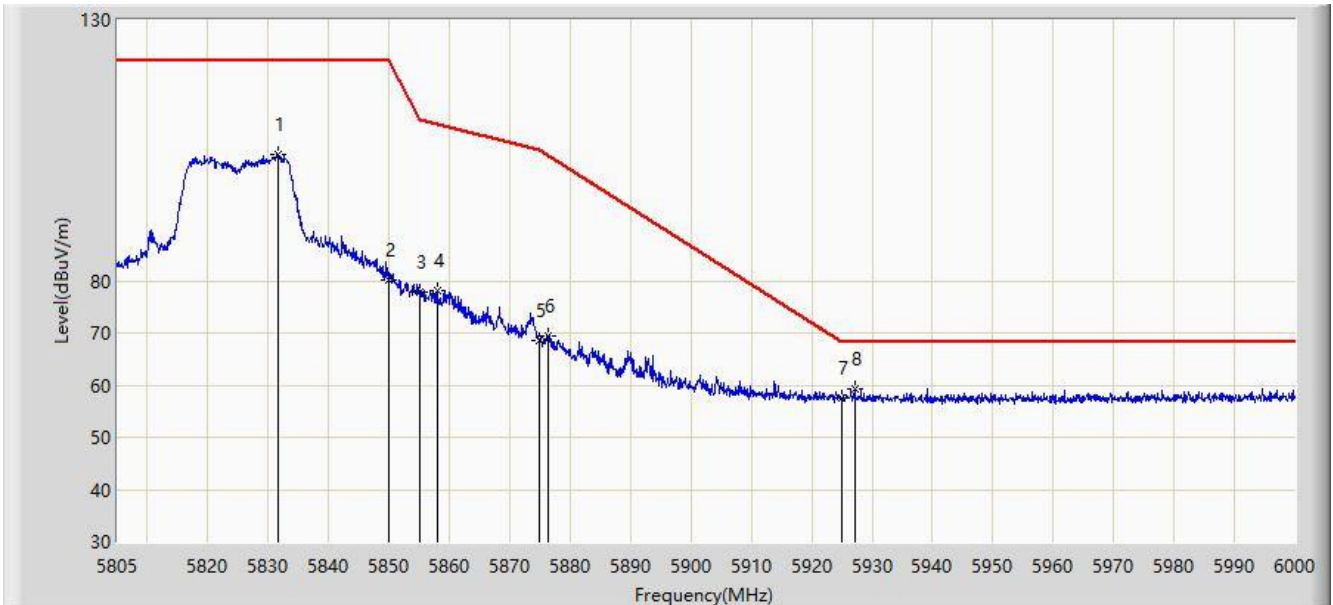

No	Flag	Mark	Frequency (MHz)	Measure Level (dBuV/m)	Reading Level (dBuV)	Over Limit (dB)	Limit (dBuV/m)	Factor (dB)	Type
1			5831.715	104.139	96.341	N/A	N/A	7.799	PK
2			5850.000	80.217	72.318	-41.983	122.200	7.899	PK
3			5855.000	77.965	70.059	-32.835	110.800	7.905	PK
4			5858.040	78.200	70.290	-31.747	109.948	7.910	PK
5			5875.000	68.483	60.575	-36.717	105.200	7.909	PK
6			5876.467	69.509	61.601	-34.601	104.110	7.908	PK
7			5925.000	57.422	49.389	-10.778	68.200	8.033	PK
8		*	5927.070	59.403	51.356	-8.797	68.200	8.047	PK

Note: Measure Level (dBuV/m) = Reading Level (dBuV) + Factor (dB)

Factor (dB) = Cable Loss (dB) + Antenna Factor (dB/m) - Pre\_Amplifier Gain (dB)

Site: AC2	Time: 2018/01/13 - 12:21
Limit: FCC_Part15.209_RE(3m)	Engineer: Snake Ni
Probe: BBHA9120D_1-18GHz	Polarity: Horizontal
EUT: Speed Dome Camera (1080P WiFi PTZ)	Power: AC 120V/60Hz
Test Mode: Transmit by 802.11n-HT40 at Channel 5190MHz	

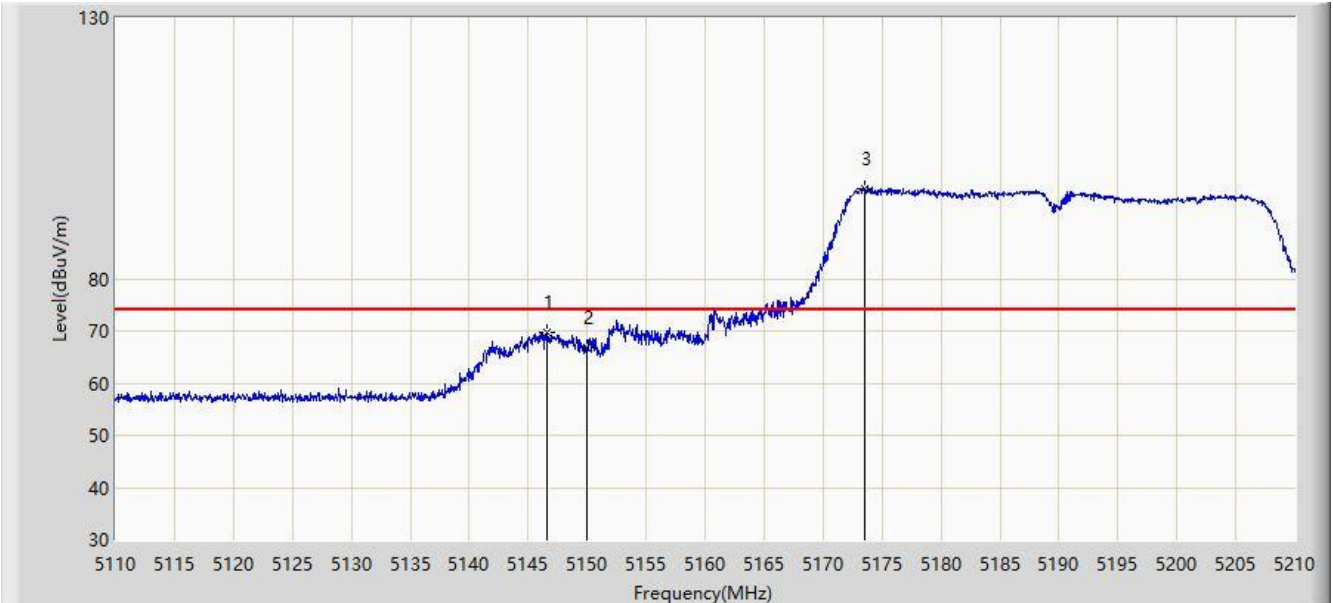

No	Flag	Mark	Frequency (MHz)	Measure Level (dBuV/m)	Reading Level (dBuV)	Over Limit (dB)	Limit (dBuV/m)	Factor (dB)	Type
1			5146.550	69.726	63.611	-4.274	74.000	6.115	PK
2			5150.000	66.725	60.602	-7.275	74.000	6.123	PK
3		*	5173.550	97.278	91.170	N/A	N/A	6.108	PK

Note: Measure Level (dBμV/m) = Reading Level (dBμV) + Factor (dB)

Factor (dB) = Cable Loss (dB) + Antenna Factor (dB/m) - Pre\_Amplifier Gain (dB)

Site: AC2	Time: 2018/01/13 - 12:20
Limit: FCC_Part15.209_RE(3m)	Engineer: Snake Ni
Probe: BBHA9120D_1-18GHz	Polarity: Horizontal
EUT: Speed Dome Camera (1080P WiFi PTZ)	Power: AC 120V/60Hz
Test Mode: Transmit by 802.11n-HT40 at Channel 5190MHz	

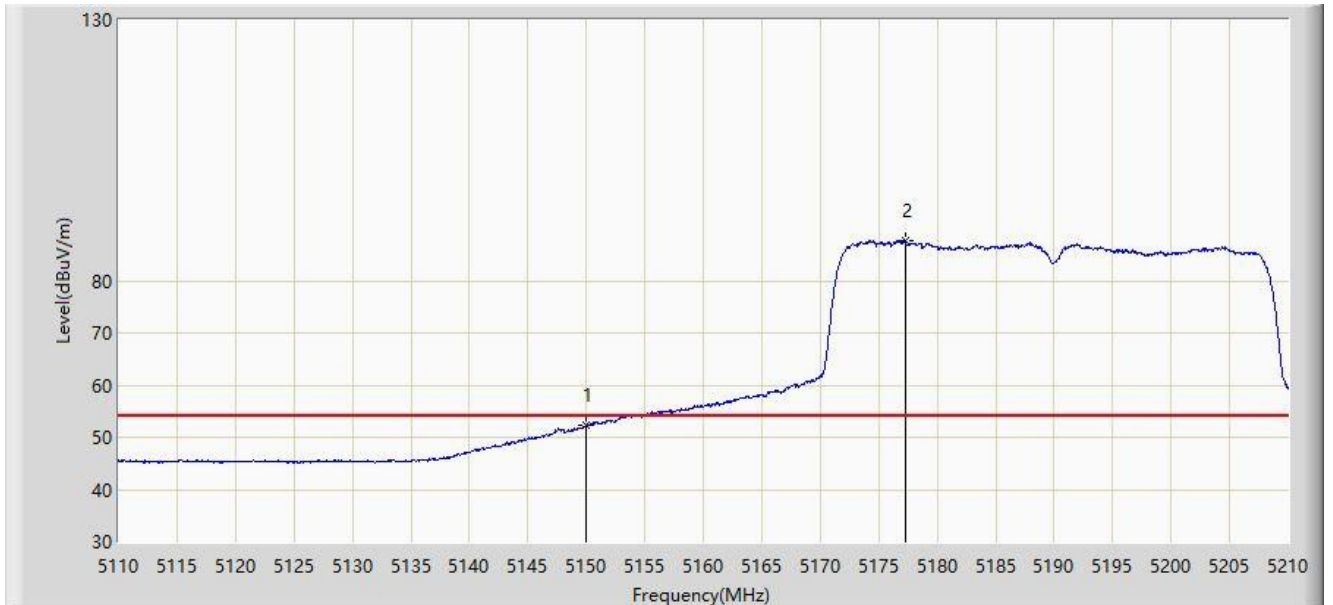

No	Flag	Mark	Frequency (MHz)	Measure Level (dBuV/m)	Reading Level (dBuV)	Over Limit (dB)	Limit (dBuV/m)	Factor (dB)	Type
1			5150.000	52.292	46.169	-1.708	54.000	6.123	AV
2		*	5177.250	87.689	81.591	N/A	N/A	6.099	AV

Note: Measure Level (dB $\mu$ V/m) = Reading Level (dB $\mu$ V) + Factor (dB)

Factor (dB) = Cable Loss (dB) + Antenna Factor (dB/m) - Pre\_Amplifier Gain (dB)

Site: AC2	Time: 2018/01/13 - 12:22
Limit: FCC_Part15.209_RE(3m)	Engineer: Snake Ni
Probe: BBHA9120D_1-18GHz	Polarity: Vertical
EUT: Speed Dome Camera (1080P WiFi PTZ)	Power: AC 120V/60Hz
Test Mode: Transmit by 802.11n-HT40 at Channel 5190MHz	

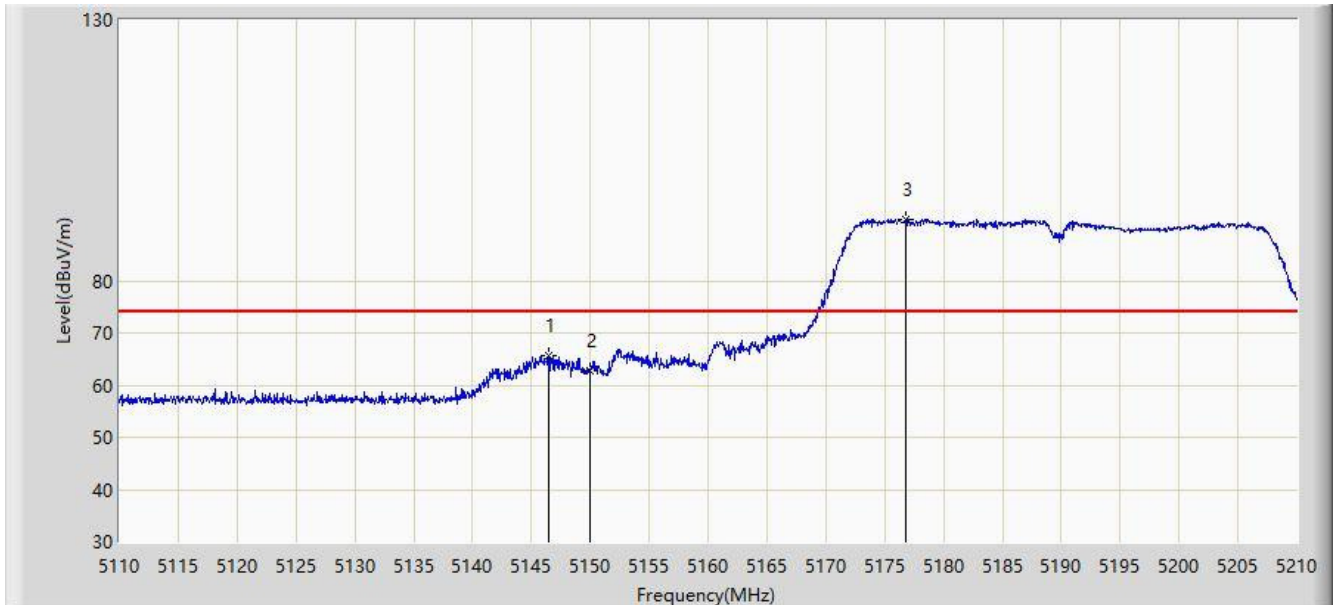

No	Flag	Mark	Frequency (MHz)	Measure Level (dBuV/m)	Reading Level (dBuV)	Over Limit (dB)	Limit (dBuV/m)	Factor (dB)	Type
1			5146.500	65.603	59.488	-8.397	74.000	6.115	PK
2			5150.000	62.610	56.487	-11.390	74.000	6.123	PK
3		*	5176.750	91.823	85.723	N/A	N/A	6.099	PK

Note: Measure Level (dB $\mu$ V/m) = Reading Level (dB $\mu$ V) + Factor (dB)

Factor (dB) = Cable Loss (dB) + Antenna Factor (dB/m) - Pre\_Amplifier Gain (dB)



Site: AC2	Time: 2018/01/13 - 12:24
Limit: FCC_Part15.209_RE(3m)	Engineer: Snake Ni
Probe: BBHA9120D_1-18GHz	Polarity: Vertical
EUT: Speed Dome Camera (1080P WiFi PTZ)	Power: AC 120V/60Hz
Test Mode: Transmit by 802.11n-HT40 at Channel 5190MHz	

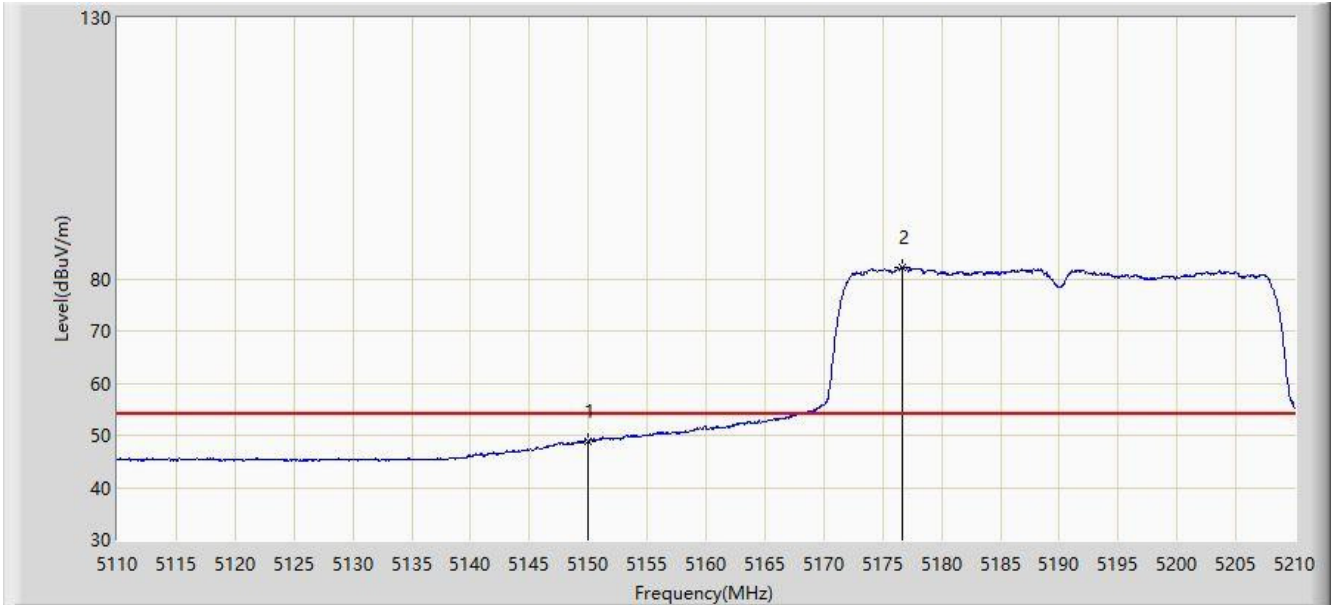

No	Flag	Mark	Frequency (MHz)	Measure Level (dBuV/m)	Reading Level (dBuV)	Over Limit (dB)	Limit (dBuV/m)	Factor (dB)	Type
1			5150.000	48.779	42.656	-5.221	54.000	6.123	AV
2		*	5176.700	82.099	75.999	N/A	N/A	6.099	AV

Note: Measure Level (dB $\mu$ V/m) = Reading Level (dB $\mu$ V) + Factor (dB)

Factor (dB) = Cable Loss (dB) + Antenna Factor (dB/m) - Pre\_Amplifier Gain (dB)

Site: AC2	Time: 2018/01/13 - 12:25
Limit: FCC_Part15.407_RE(3m)_Bandedge	Engineer: Snake Ni
Probe: BBHA9120D_1-18GHz	Polarity: Horizontal
EUT: Speed Dome Camera (1080P WiFi PTZ)	Power: AC 120V/60Hz
Test Mode: Transmit by 802.11n-HT40 at Channel 5755MHz	

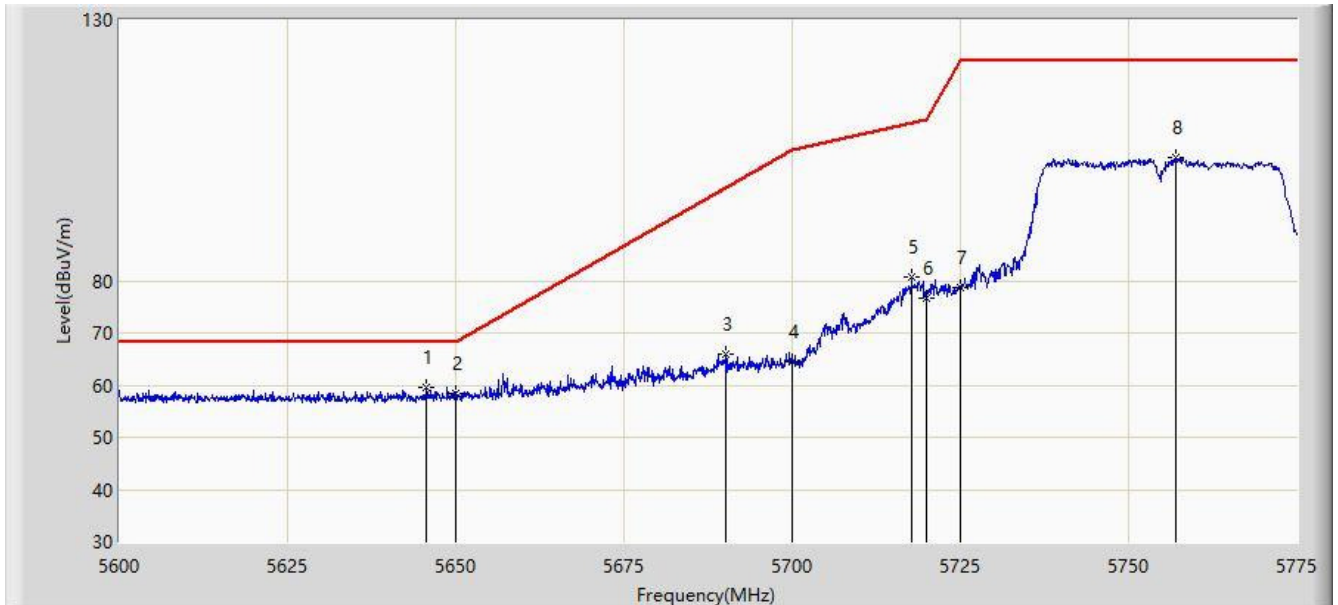

No	Flag	Mark	Frequency (MHz)	Measure Level (dBuV/m)	Reading Level (dBuV)	Over Limit (dB)	Limit (dBuV/m)	Factor (dB)	Type
1		*	5645.675	59.426	52.467	-8.774	68.200	6.958	PK
2			5650.000	58.324	51.341	-9.876	68.200	6.983	PK
3			5690.125	65.897	58.928	-32.021	97.918	6.970	PK
4			5700.000	64.603	57.625	-40.597	105.200	6.978	PK
5			5717.775	80.725	73.633	-29.453	110.178	7.091	PK
6			5720.000	76.782	69.668	-34.018	110.800	7.114	PK
7			5725.000	78.769	71.604	-43.431	122.200	7.165	PK
8			5757.062	103.700	96.265	N/A	N/A	7.435	PK

Note: Measure Level (dBuV/m) = Reading Level (dBuV) + Factor (dB)

Factor (dB) = Cable Loss (dB) + Antenna Factor (dB/m) - Pre\_Amplifier Gain (dB)

Site: AC2	Time: 2018/01/13 - 12:27
Limit: FCC_Part15.407_RE(3m)_Bandedge	Engineer: Snake Ni
Probe: BBHA9120D_1-18GHz	Polarity: Vertical
EUT: Speed Dome Camera (1080P WiFi PTZ)	Power: AC 120V/60Hz
Test Mode: Transmit by 802.11n-HT40 at Channel 5755MHz	

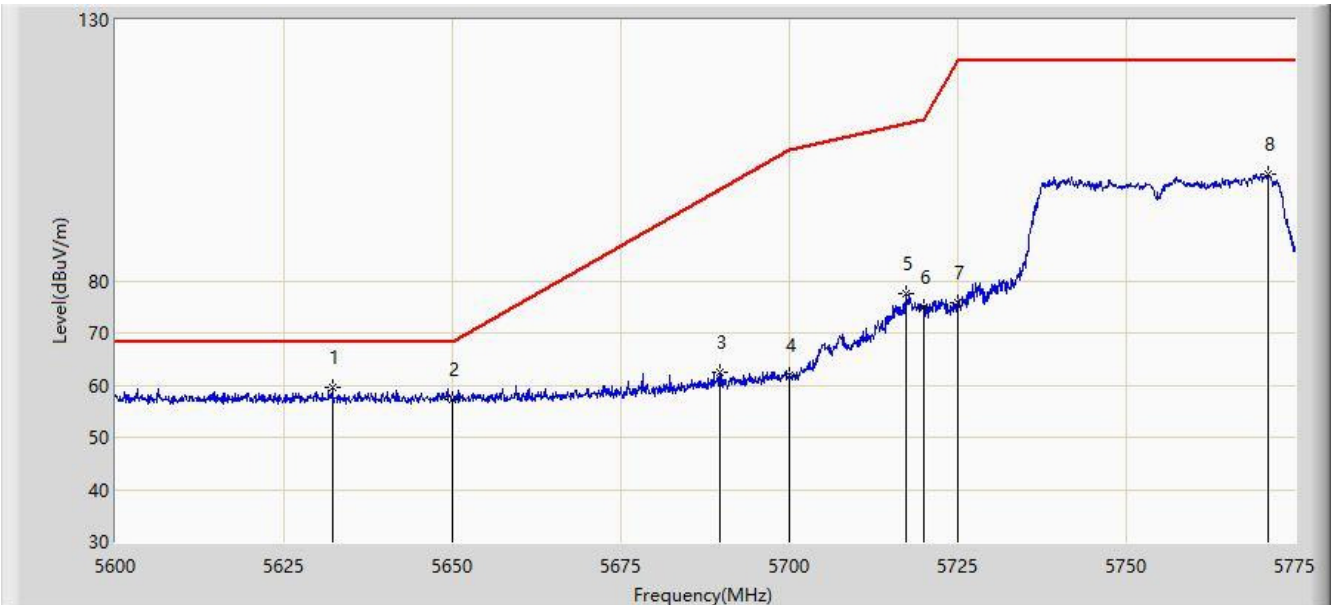

No	Flag	Mark	Frequency (MHz)	Measure Level (dBuV/m)	Reading Level (dBuV)	Over Limit (dB)	Limit (dBuV/m)	Factor (dB)	Type
1		*	5632.200	59.553	52.694	-8.647	68.200	6.859	PK
2			5650.000	57.161	50.178	-11.039	68.200	6.983	PK
3			5689.600	62.463	55.493	-35.068	97.531	6.971	PK
4			5700.000	62.012	55.034	-43.188	105.200	6.978	PK
5			5717.250	77.417	70.331	-32.614	110.031	7.086	PK
6			5720.000	74.958	67.844	-35.842	110.800	7.114	PK
7			5725.000	75.862	68.697	-46.338	122.200	7.165	PK
8			5771.062	100.398	92.959	N/A	N/A	7.440	PK

Note: Measure Level (dBuV/m) = Reading Level (dBuV) + Factor (dB)

Factor (dB) = Cable Loss (dB) + Antenna Factor (dB/m) - Pre\_Amplifier Gain (dB)

Site: AC2	Time: 2018/01/13 - 12:28
Limit: FCC_Part15.407_RE(3m)_Bandedge	Engineer: Snake Ni
Probe: BBHA9120D_1-18GHz	Polarity: Horizontal
EUT: Speed Dome Camera (1080P WiFi PTZ)	Power: AC 120V/60Hz
Test Mode: Transmit by 802.11n-HT40 at Channel 5795MHz	

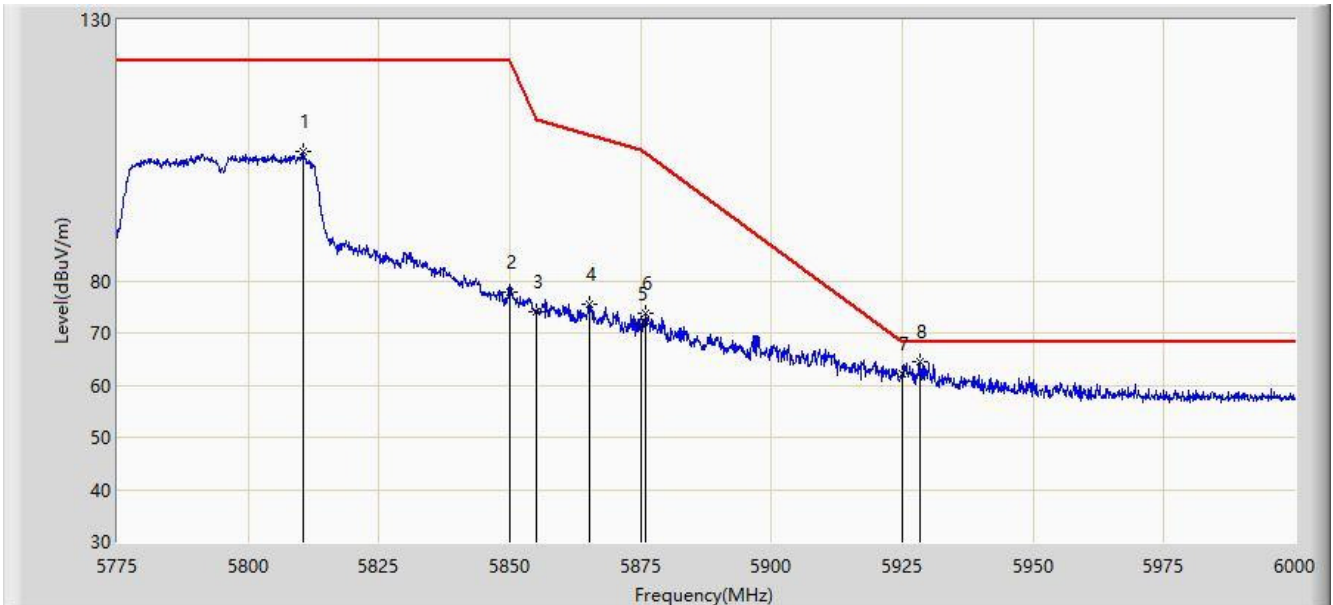

No	Flag	Mark	Frequency (MHz)	Measure Level (dBuV/m)	Reading Level (dBuV)	Over Limit (dB)	Limit (dBuV/m)	Factor (dB)	Type
1			5810.437	104.867	97.287	N/A	N/A	7.580	PK
2			5850.000	77.941	70.042	-44.259	122.200	7.899	PK
3			5855.000	73.988	66.082	-36.812	110.800	7.905	PK
4			5865.112	75.601	67.687	-32.365	107.966	7.914	PK
5			5875.000	71.604	63.696	-33.596	105.200	7.909	PK
6			5876.025	73.824	65.916	-30.615	104.438	7.908	PK
7			5925.000	62.281	54.248	-5.919	68.200	8.033	PK
8		*	5928.450	64.367	56.310	-3.833	68.200	8.057	PK

Note: Measure Level (dBuV/m) = Reading Level (dBuV) + Factor (dB)

Factor (dB) = Cable Loss (dB) + Antenna Factor (dB/m) - Pre\_Amplifier Gain (dB)

Site: AC2	Time: 2018/01/13 - 12:30
Limit: FCC_Part15.407_RE(3m)_Bandedge	Engineer: Snake Ni
Probe: BBHA9120D_1-18GHz	Polarity: Vertical
EUT: Speed Dome Camera (1080P WiFi PTZ)	Power: AC 120V/60Hz
Test Mode: Transmit by 802.11n-HT40 at Channel 5795MHz	

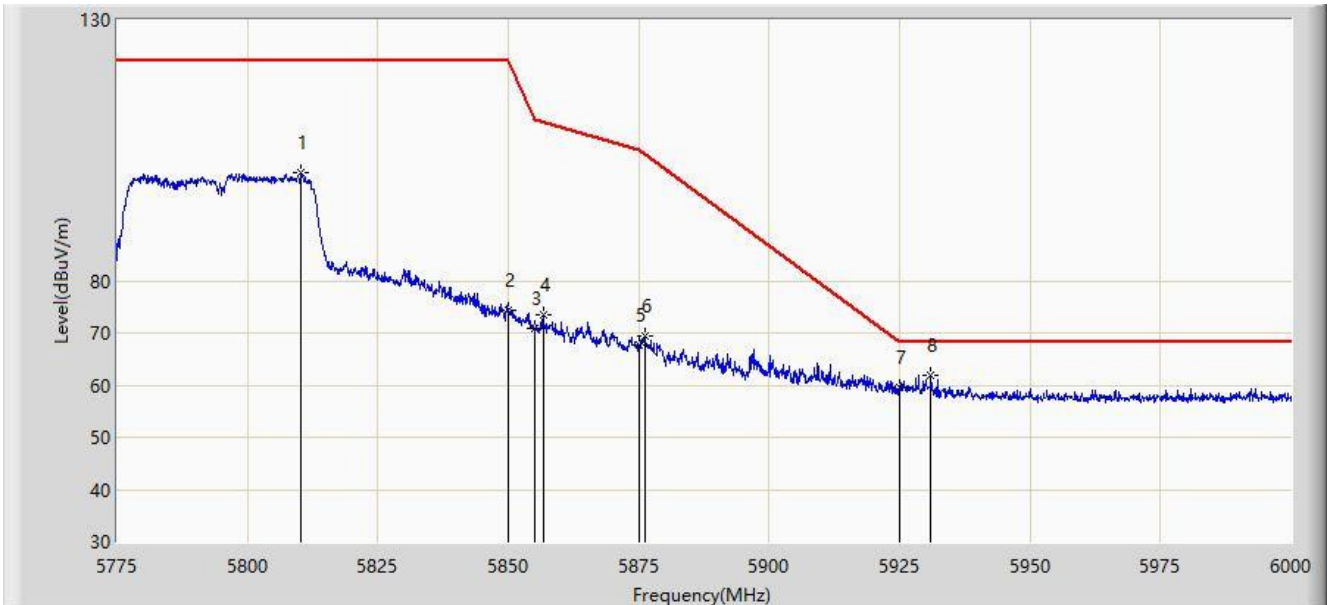

No	Flag	Mark	Frequency (MHz)	Measure Level (dBuV/m)	Reading Level (dBuV)	Over Limit (dB)	Limit (dBuV/m)	Factor (dB)	Type
1			5810.212	100.844	93.266	N/A	N/A	7.578	PK
2			5850.000	74.227	66.328	-47.973	122.200	7.899	PK
3			5855.000	70.738	62.832	-40.062	110.800	7.905	PK
4			5856.675	73.382	65.474	-36.948	110.330	7.908	PK
5			5875.000	67.625	59.717	-37.575	105.200	7.909	PK
6			5876.138	69.494	61.586	-34.861	104.354	7.908	PK
7			5925.000	59.656	51.623	-8.544	68.200	8.033	PK
8		*	5930.925	62.007	53.938	-6.193	68.200	8.069	PK

Note: Measure Level (dBuV/m) = Reading Level (dBuV) + Factor (dB)

Factor (dB) = Cable Loss (dB) + Antenna Factor (dB/m) - Pre\_Amplifier Gain (dB)

Site: AC2	Time: 2018/01/13 - 12:32
Limit: FCC_Part15.209_RE(3m)	Engineer: Snake Ni
Probe: BBHA9120D_1-18GHz	Polarity: Horizontal
EUT: Speed Dome Camera (1080P WiFi PTZ)	Power: AC 120V/60Hz
Test Mode: Transmit by 802.11ac-VHT20 at Channel 5180MHz	

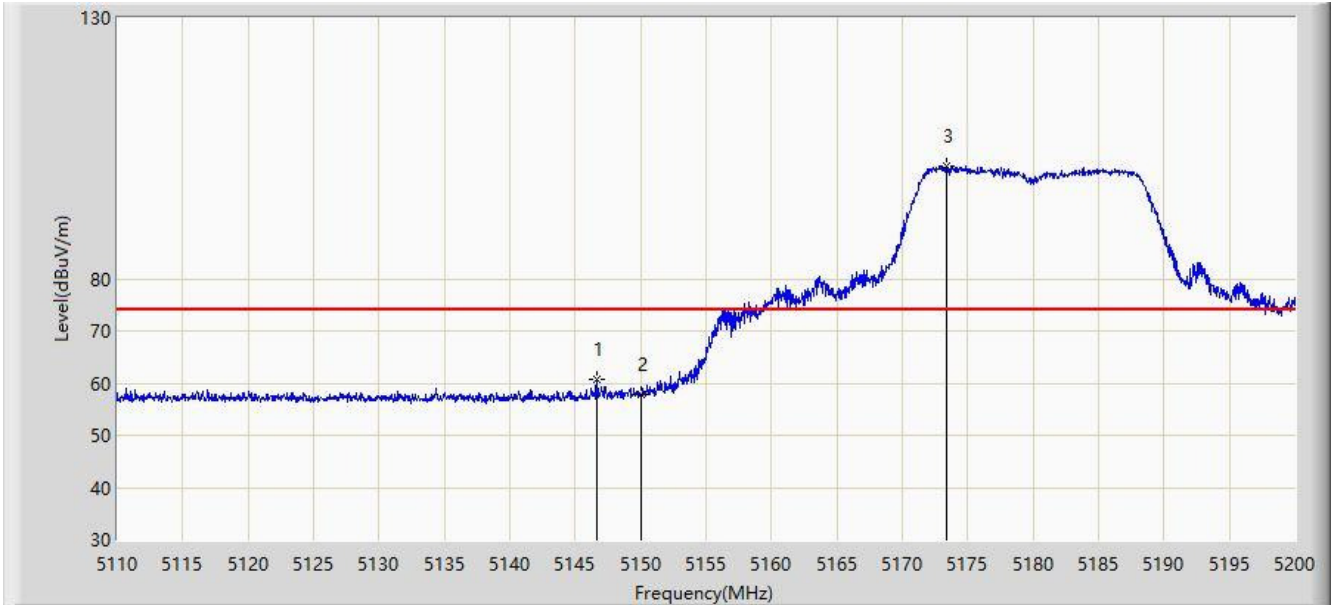

No	Flag	Mark	Frequency (MHz)	Measure Level (dBuV/m)	Reading Level (dBuV)	Over Limit (dB)	Limit (dBuV/m)	Factor (dB)	Type
1			5146.630	60.581	54.466	-13.419	74.000	6.115	PK
2			5150.000	57.824	51.701	-16.176	74.000	6.123	PK
3		*	5173.360	101.659	95.550	N/A	N/A	6.109	PK

Note: Measure Level (dBμV/m) = Reading Level (dBμV) + Factor (dB)

Factor (dB) = Cable Loss (dB) + Antenna Factor (dB/m) - Pre\_Amplifier Gain (dB)

Site: AC2	Time: 2018/01/13 - 12:33
Limit: FCC_Part15.209_RE(3m)	Engineer: Snake Ni
Probe: BBHA9120D_1-18GHz	Polarity: Horizontal
EUT: Speed Dome Camera (1080P WiFi PTZ)	Power: AC 120V/60Hz
Test Mode: Transmit by 802.11ac-VHT20 at Channel 5180MHz	

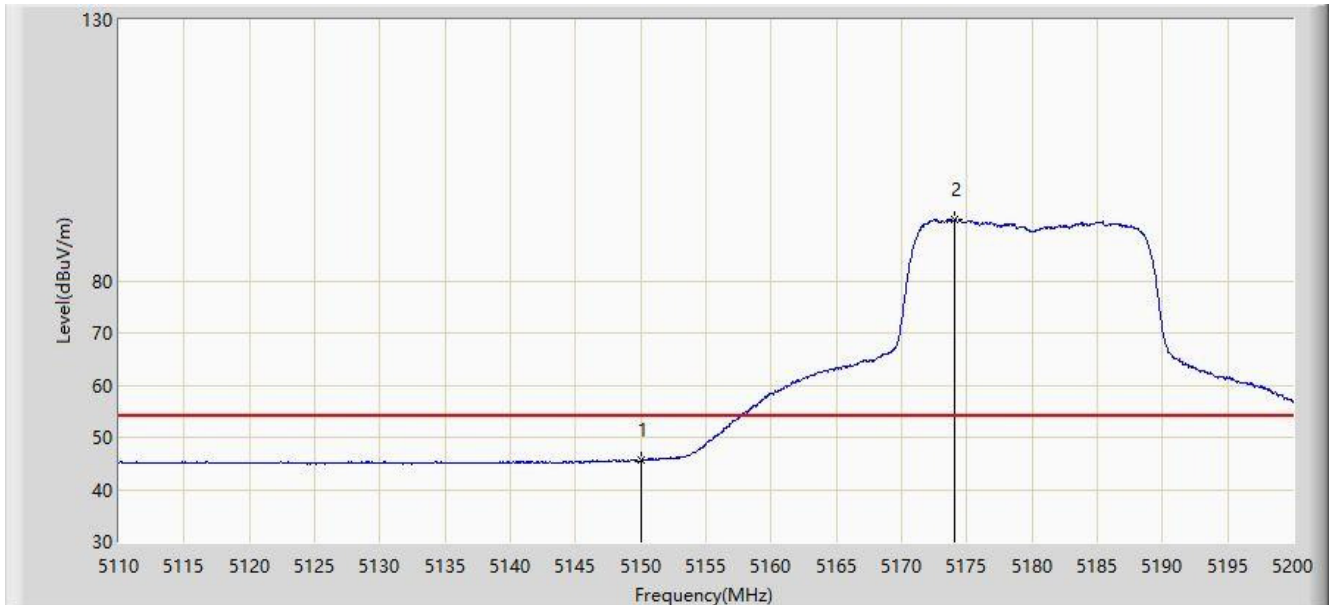

No	Flag	Mark	Frequency (MHz)	Measure Level (dBuV/m)	Reading Level (dBuV)	Over Limit (dB)	Limit (dBuV/m)	Factor (dB)	Type
1			5150.000	45.510	39.387	-8.490	54.000	6.123	AV
2		*	5174.080	91.705	85.598	N/A	N/A	6.106	AV

Note: Measure Level (dB $\mu$ V/m) = Reading Level (dB $\mu$ V) + Factor (dB)

Factor (dB) = Cable Loss (dB) + Antenna Factor (dB/m) - Pre\_Amplifier Gain (dB)

Site: AC2	Time: 2018/01/13 - 12:36
Limit: FCC_Part15.209_RE(3m)	Engineer: Snake Ni
Probe: BBHA9120D_1-18GHz	Polarity: Vertical
EUT: Speed Dome Camera (1080P WiFi PTZ)	Power: AC 120V/60Hz
Test Mode: Transmit by 802.11ac-VHT20 at Channel 5180MHz	

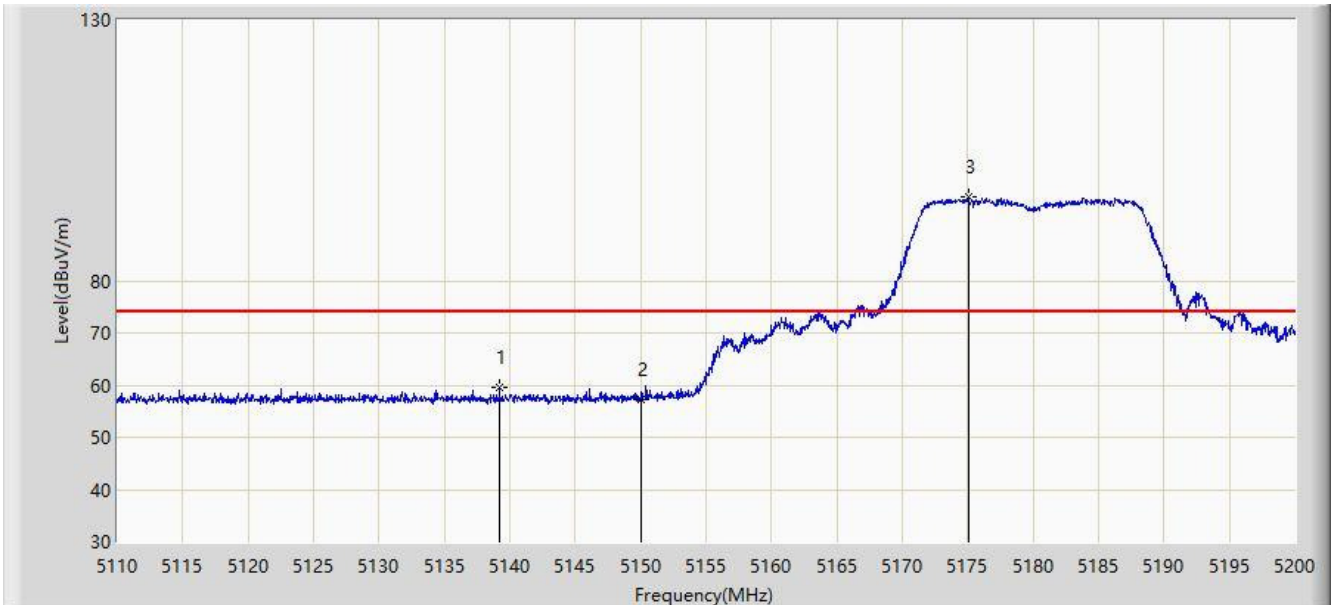

No	Flag	Mark	Frequency (MHz)	Measure Level (dBuV/m)	Reading Level (dBuV)	Over Limit (dB)	Limit (dBuV/m)	Factor (dB)	Type
1			5139.205	59.600	53.506	-14.400	74.000	6.094	PK
2			5150.000	57.358	51.235	-16.642	74.000	6.123	PK
3		*	5175.070	96.175	90.071	N/A	N/A	6.104	PK

Note: Measure Level (dB $\mu$ V/m) = Reading Level (dB $\mu$ V) + Factor (dB)

Factor (dB) = Cable Loss (dB) + Antenna Factor (dB/m) - Pre\_Amplifier Gain (dB)



Site: AC2	Time: 2018/01/13 - 12:37
Limit: FCC_Part15.209_RE(3m)	Engineer: Snake Ni
Probe: BBHA9120D_1-18GHz	Polarity: Vertical
EUT: Speed Dome Camera (1080P WiFi PTZ)	Power: AC 120V/60Hz
Test Mode: Transmit by 802.11ac-VHT20 at Channel 5180MHz	

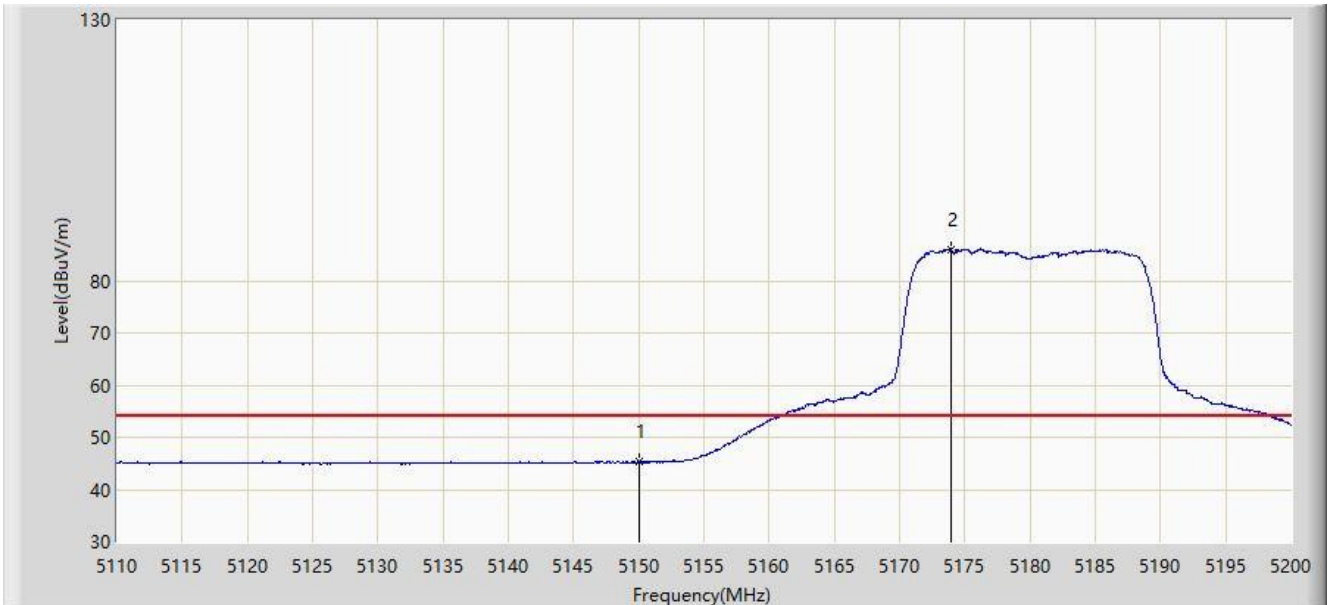

No	Flag	Mark	Frequency (MHz)	Measure Level (dBuV/m)	Reading Level (dBuV)	Over Limit (dB)	Limit (dBuV/m)	Factor (dB)	Type
1			5150.000	45.255	39.132	-8.745	54.000	6.123	AV
2		*	5173.900	86.069	79.962	N/A	N/A	6.107	AV

Note: Measure Level (dB $\mu$ V/m) = Reading Level (dB $\mu$ V) + Factor (dB)

Factor (dB) = Cable Loss (dB) + Antenna Factor (dB/m) - Pre\_Amplifier Gain (dB)

Site: AC2	Time: 2018/01/13 - 12:38
Limit: FCC_Part15.407_RE(3m)_Bandedge	Engineer: Snake Ni
Probe: BBHA9120D_1-18GHz	Polarity: Horizontal
EUT: Speed Dome Camera (1080P WiFi PTZ)	Power: AC 120V/60Hz
Test Mode: Transmit by 802.11ac-VHT20 at Channel 5745MHz	

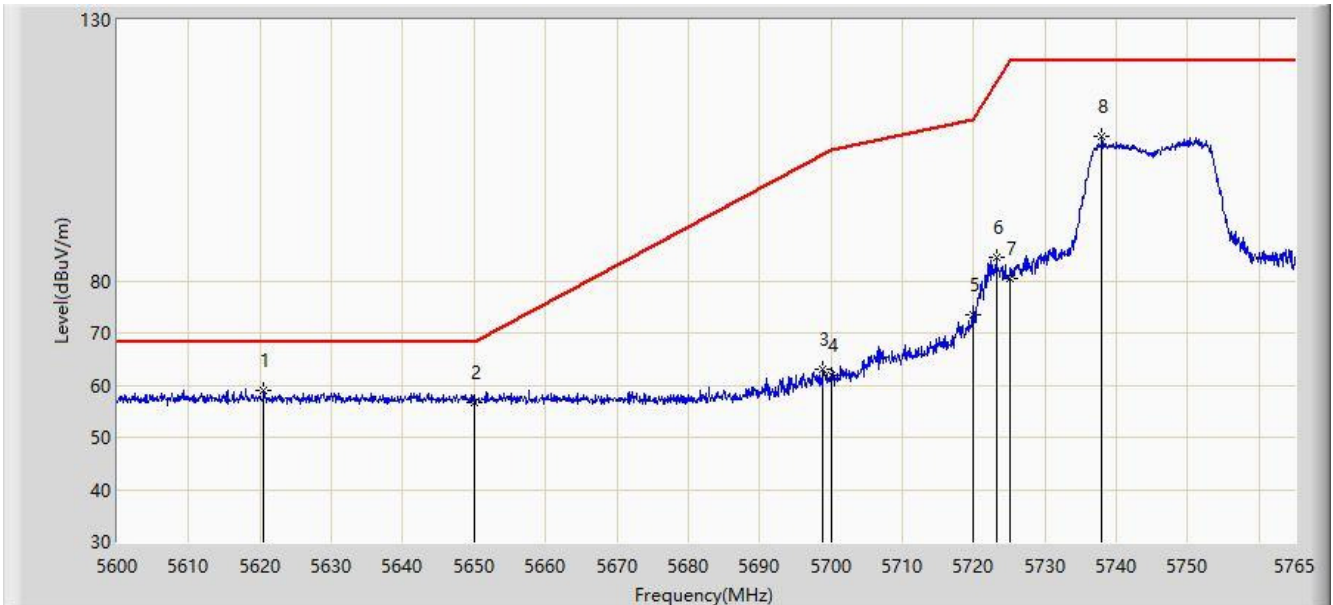

No	Flag	Mark	Frequency (MHz)	Measure Level (dBuV/m)	Reading Level (dBuV)	Over Limit (dB)	Limit (dBuV/m)	Factor (dB)	Type
1		*	5620.542	59.107	52.343	-9.093	68.200	6.764	PK
2			5650.000	56.577	49.594	-11.623	68.200	6.983	PK
3			5698.917	62.928	55.952	-41.474	104.402	6.977	PK
4			5700.000	61.744	54.766	-43.456	105.200	6.978	PK
5			5720.000	73.516	66.402	-37.284	110.800	7.114	PK
6			5723.172	84.464	77.317	-33.570	118.033	7.147	PK
7			5725.000	80.519	73.354	-41.681	122.200	7.165	PK
8			5737.940	107.559	100.267	N/A	N/A	7.292	PK

Note: Measure Level (dBuV/m) = Reading Level (dBuV) + Factor (dB)

Factor (dB) = Cable Loss (dB) + Antenna Factor (dB/m) - Pre\_Amplifier Gain (dB)

Site: AC2	Time: 2018/01/13 - 12:40
Limit: FCC_Part15.407_RE(3m)_Bandedge	Engineer: Snake Ni
Probe: BBHA9120D_1-18GHz	Polarity: Vertical
EUT: Speed Dome Camera (1080P WiFi PTZ)	Power: AC 120V/60Hz
Test Mode: Transmit by 802.11ac-VHT20 at Channel 5745MHz	

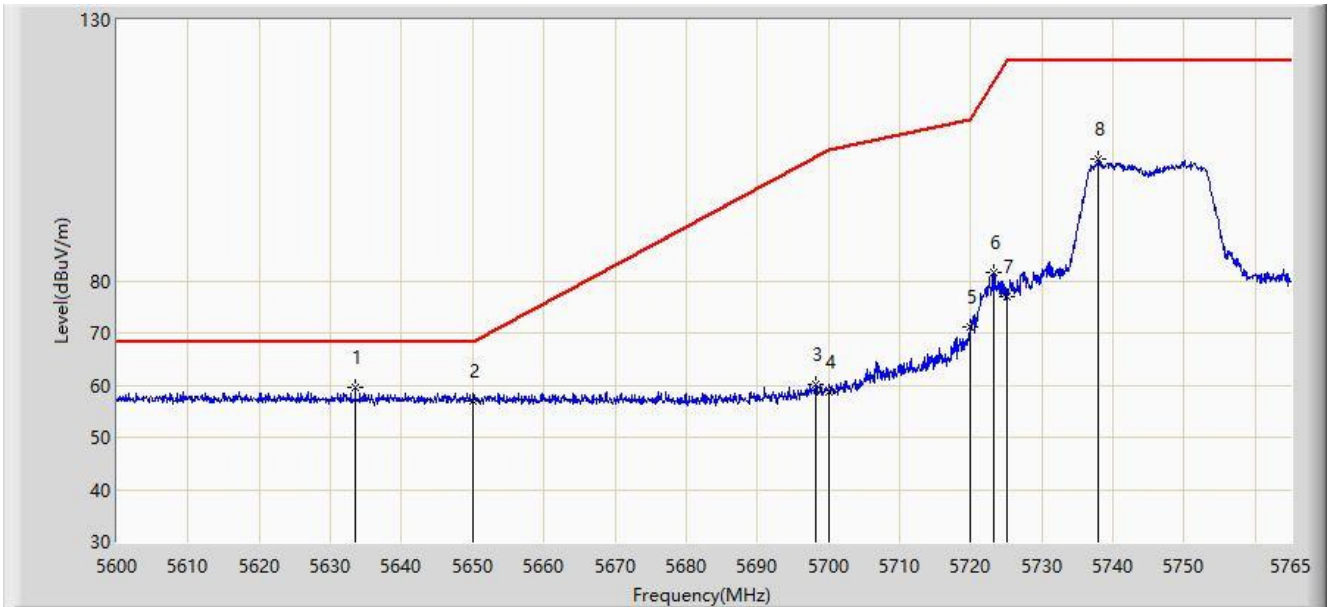

No	Flag	Mark	Frequency (MHz)	Measure Level (dBuV/m)	Reading Level (dBuV)	Over Limit (dB)	Limit (dBuV/m)	Factor (dB)	Type
1		*	5633.495	59.545	52.675	-8.655	68.200	6.870	PK
2			5650.000	56.946	49.963	-11.254	68.200	6.983	PK
3			5698.175	60.285	53.310	-43.570	103.855	6.976	PK
4			5700.000	58.839	51.861	-46.361	105.200	6.978	PK
5			5720.000	71.086	63.972	-39.714	110.800	7.114	PK
6			5723.172	81.494	74.347	-36.540	118.033	7.147	PK
7			5725.000	76.817	69.652	-45.383	122.200	7.165	PK
8			5737.940	103.317	96.025	N/A	N/A	7.292	PK

Note: Measure Level (dBuV/m) = Reading Level (dBuV) + Factor (dB)

Factor (dB) = Cable Loss (dB) + Antenna Factor (dB/m) - Pre\_Amplifier Gain (dB)

Site: AC2	Time: 2018/01/13 - 12:41
Limit: FCC_Part15.407_RE(3m)_Bandedge	Engineer: Snake Ni
Probe: BBHA9120D_1-18GHz	Polarity: Horizontal
EUT: Speed Dome Camera (1080P WiFi PTZ)	Power: AC 120V/60Hz
Test Mode: Transmit by 802.11ac-VHT20 at Channel 5825MHz	

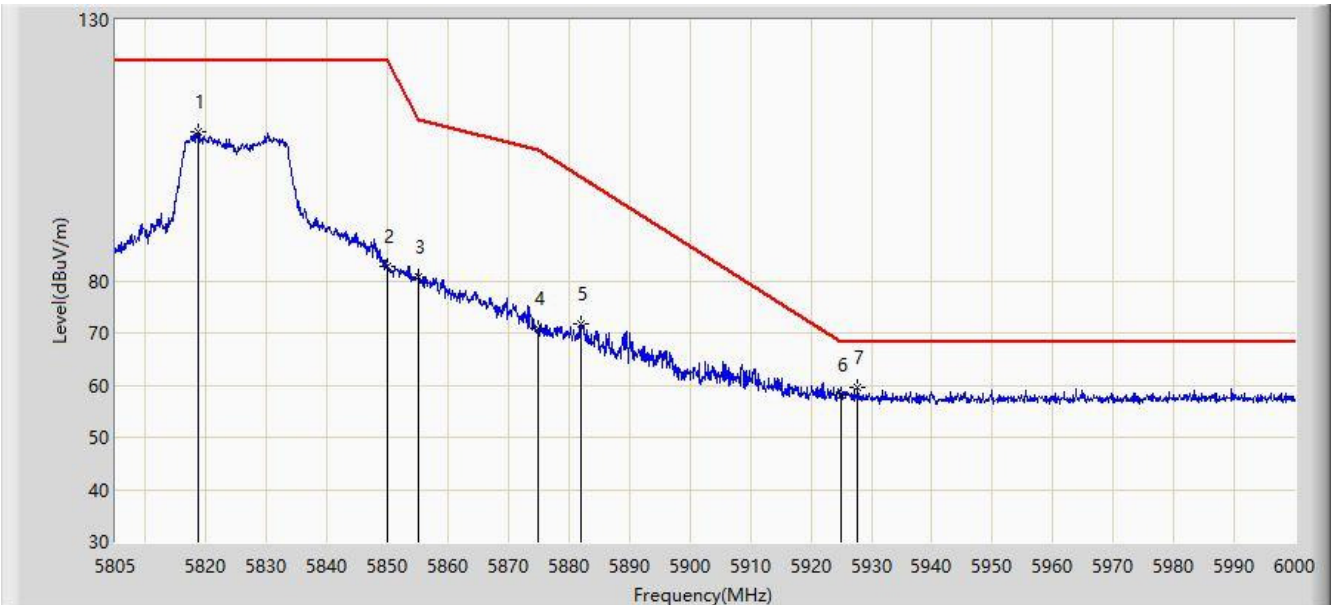

No	Flag	Mark	Frequency (MHz)	Measure Level (dBuV/m)	Reading Level (dBuV)	Over Limit (dB)	Limit (dBuV/m)	Factor (dB)	Type
1			5818.650	108.559	100.890	N/A	N/A	7.669	PK
2			5850.000	82.670	74.771	-39.530	122.200	7.899	PK
3			5855.000	80.845	72.939	-29.955	110.800	7.905	PK
4			5875.000	70.931	63.023	-34.269	105.200	7.909	PK
5			5882.025	71.766	63.858	-28.217	99.983	7.907	PK
6			5925.000	58.244	50.211	-9.956	68.200	8.033	PK
7		*	5927.655	59.648	51.597	-8.552	68.200	8.051	PK

Note: Measure Level (dBμV/m) = Reading Level (dBμV) + Factor (dB)

Factor (dB) = Cable Loss (dB) + Antenna Factor (dB/m) - Pre\_Amplifier Gain (dB)

Site: AC2	Time: 2018/01/13 - 12:43
Limit: FCC_Part15.407_RE(3m)_Bandedge	Engineer: Snake Ni
Probe: BBHA9120D_1-18GHz	Polarity: Vertical
EUT: Speed Dome Camera (1080P WiFi PTZ)	Power: AC 120V/60Hz
Test Mode: Transmit by 802.11ac-VHT20 at Channel 5825MHz	

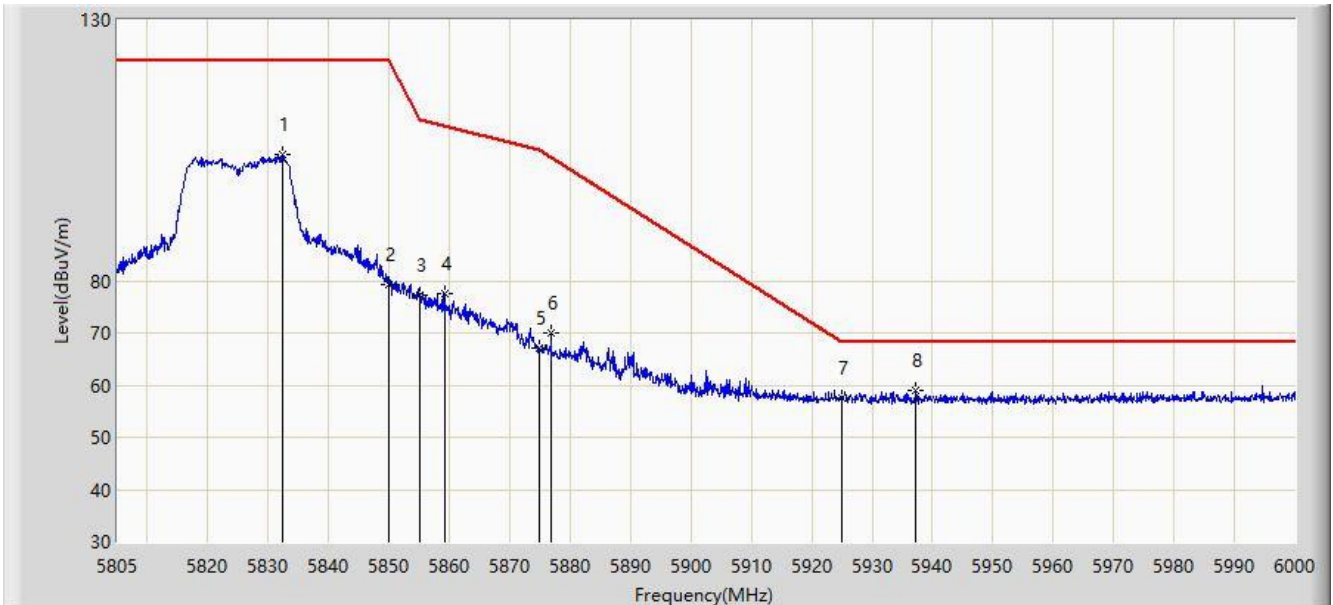

No	Flag	Mark	Frequency (MHz)	Measure Level (dBuV/m)	Reading Level (dBuV)	Over Limit (dB)	Limit (dBuV/m)	Factor (dB)	Type
1			5832.397	104.126	96.323	N/A	N/A	7.803	PK
2			5850.000	79.316	71.417	-42.884	122.200	7.899	PK
3			5855.000	77.220	69.314	-33.580	110.800	7.905	PK
4			5859.210	77.406	69.494	-32.214	109.620	7.912	PK
5			5875.000	67.183	59.275	-38.017	105.200	7.909	PK
6			5876.857	70.011	62.104	-33.809	103.820	7.908	PK
7			5925.000	57.522	49.489	-10.678	68.200	8.033	PK
8		*	5937.308	59.045	50.967	-9.155	68.200	8.078	PK

Note: Measure Level (dBuV/m) = Reading Level (dBuV) + Factor (dB)

Factor (dB) = Cable Loss (dB) + Antenna Factor (dB/m) - Pre\_Amplifier Gain (dB)

Site: AC2	Time: 2018/01/13 - 12:48
Limit: FCC_Part15.209_RE(3m)	Engineer: Snake Ni
Probe: BBHA9120D_1-18GHz	Polarity: Horizontal
EUT: Speed Dome Camera (1080P WiFi PTZ)	Power: AC 120V/60Hz
Test Mode: Transmit by 802.11ac-VHT40 at Channel 5190MHz	

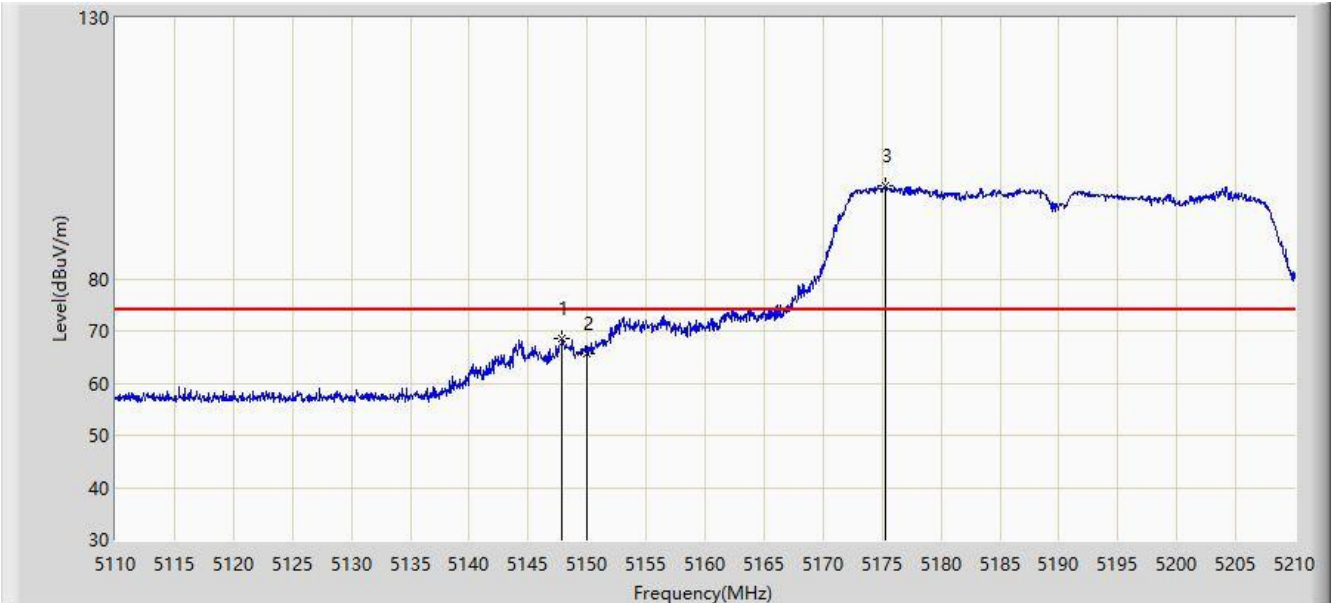

No	Flag	Mark	Frequency (MHz)	Measure Level (dBuV/m)	Reading Level (dBuV)	Over Limit (dB)	Limit (dBuV/m)	Factor (dB)	Type
1			5147.850	68.492	62.374	-5.508	74.000	6.119	PK
2			5150.000	65.516	59.393	-8.484	74.000	6.123	PK
3		*	5175.300	97.684	91.580	N/A	N/A	6.103	PK

Note: Measure Level (dBμV/m) = Reading Level (dBμV) + Factor (dB)

Factor (dB) = Cable Loss (dB) + Antenna Factor (dB/m) - Pre\_Amplifier Gain (dB)

Site: AC2	Time: 2018/01/13 - 12:47
Limit: FCC_Part15.209_RE(3m)	Engineer: Snake Ni
Probe: BBHA9120D_1-18GHz	Polarity: Horizontal
EUT: Speed Dome Camera (1080P WiFi PTZ)	Power: AC 120V/60Hz
Test Mode: Transmit by 802.11ac-VHT40 at Channel 5190MHz	

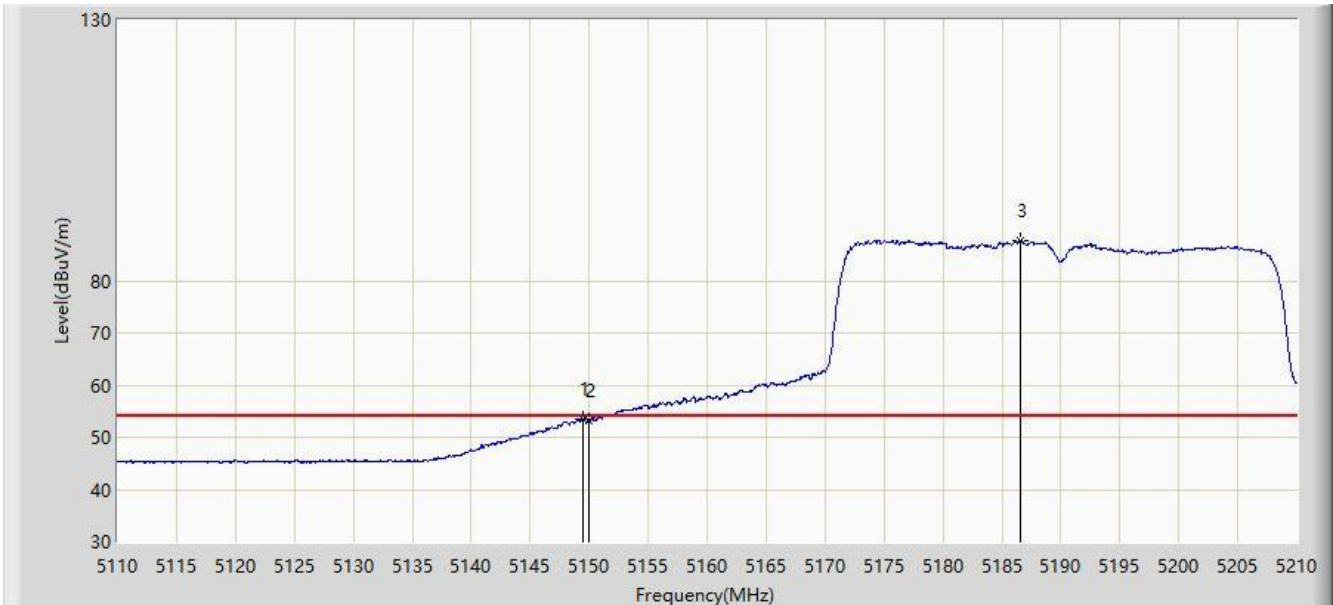

No	Flag	Mark	Frequency (MHz)	Measure Level (dBuV/m)	Reading Level (dBuV)	Over Limit (dB)	Limit (dBuV/m)	Factor (dB)	Type
1			5149.450	53.502	47.380	-0.498	54.000	6.122	AV
2			5150.000	53.250	47.127	-0.750	54.000	6.123	AV
3		*	5186.550	87.625	81.576	N/A	N/A	6.049	AV

Note: Measure Level (dBμV/m) = Reading Level (dBμV) + Factor (dB)

Factor (dB) = Cable Loss (dB) + Antenna Factor (dB/m) - Pre\_Amplifier Gain (dB)

Site: AC2	Time: 2018/01/13 - 12:49
Limit: FCC_Part15.209_RE(3m)	Engineer: Snake Ni
Probe: BBHA9120D_1-18GHz	Polarity: Vertical
EUT: Speed Dome Camera (1080P WiFi PTZ)	Power: AC 120V/60Hz
Test Mode: Transmit by 802.11ac-VHT40 at Channel 5190MHz	

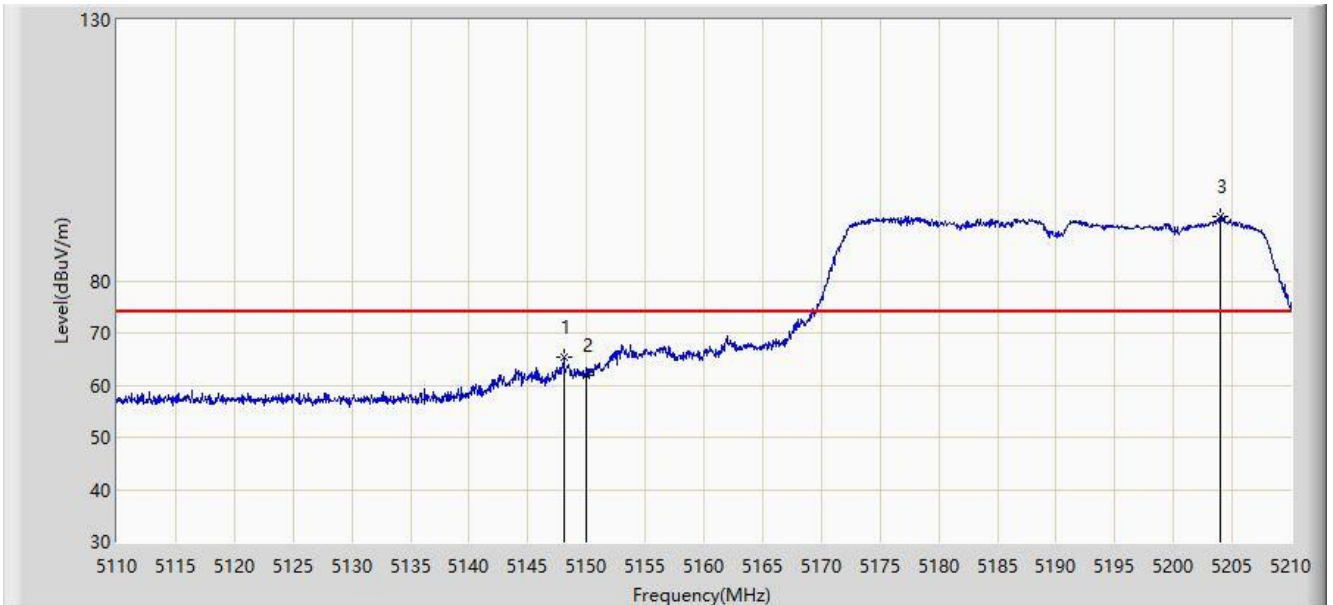

No	Flag	Mark	Frequency (MHz)	Measure Level (dBuV/m)	Reading Level (dBuV)	Over Limit (dB)	Limit (dBuV/m)	Factor (dB)	Type
1			5148.050	65.264	59.145	-8.736	74.000	6.119	PK
2			5150.000	61.909	55.786	-12.091	74.000	6.123	PK
3		*	5204.000	92.348	86.444	N/A	N/A	5.904	PK

Note: Measure Level (dBμV/m) = Reading Level (dBμV) + Factor (dB)

Factor (dB) = Cable Loss (dB) + Antenna Factor (dB/m) - Pre\_Amplifier Gain (dB)



Site: AC2	Time: 2018/01/13 - 12:50
Limit: FCC_Part15.209_RE(3m)	Engineer: Snake Ni
Probe: BBHA9120D_1-18GHz	Polarity: Vertical
EUT: Speed Dome Camera (1080P WiFi PTZ)	Power: AC 120V/60Hz
Test Mode: Transmit by 802.11ac-VHT40 at Channel 5190MHz	

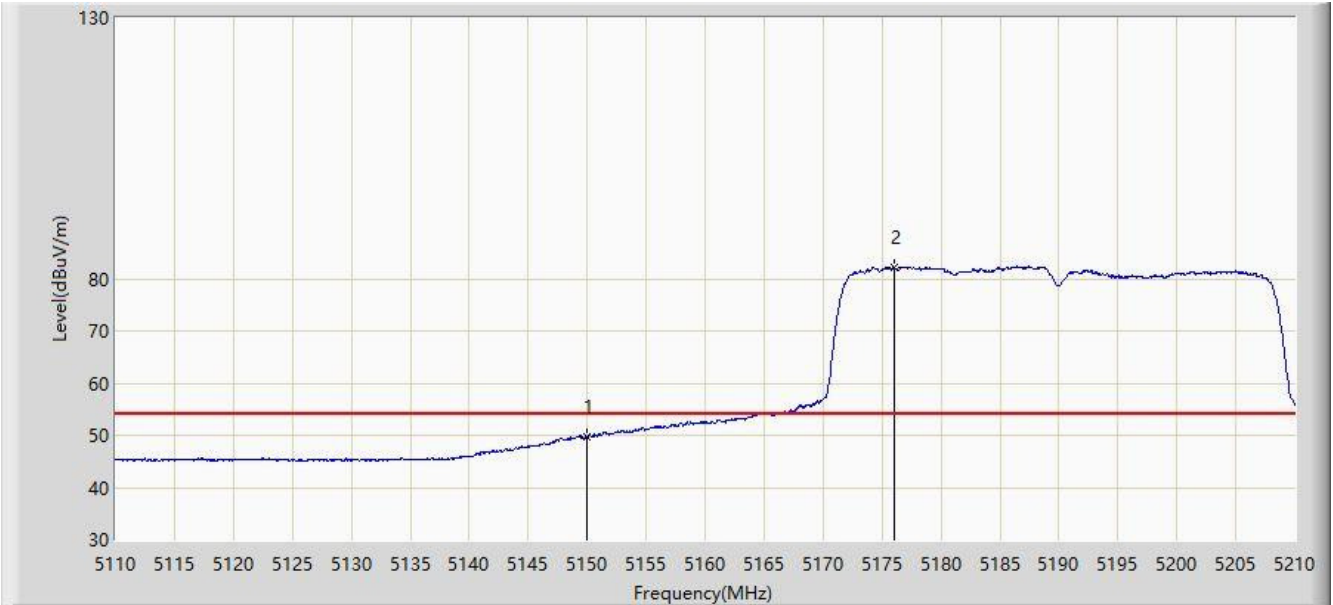

No	Flag	Mark	Frequency (MHz)	Measure Level (dBuV/m)	Reading Level (dBuV)	Over Limit (dB)	Limit (dBuV/m)	Factor (dB)	Type
1			5150.000	49.626	43.503	-4.374	54.000	6.123	AV
2		*	5176.050	82.289	76.188	N/A	N/A	6.102	AV

Note: Measure Level (dBμV/m) = Reading Level (dBμV) + Factor (dB)

Factor (dB) = Cable Loss (dB) + Antenna Factor (dB/m) - Pre\_Amplifier Gain (dB)

Site: AC2	Time: 2018/01/13 - 12:51
Limit: FCC_Part15.407_RE(3m)_Bandedge	Engineer: Snake Ni
Probe: BBHA9120D_1-18GHz	Polarity: Horizontal
EUT: Speed Dome Camera (1080P WiFi PTZ)	Power: AC 120V/60Hz
Test Mode: Transmit by 802.11ac-VHT40 at Channel 5755MHz	

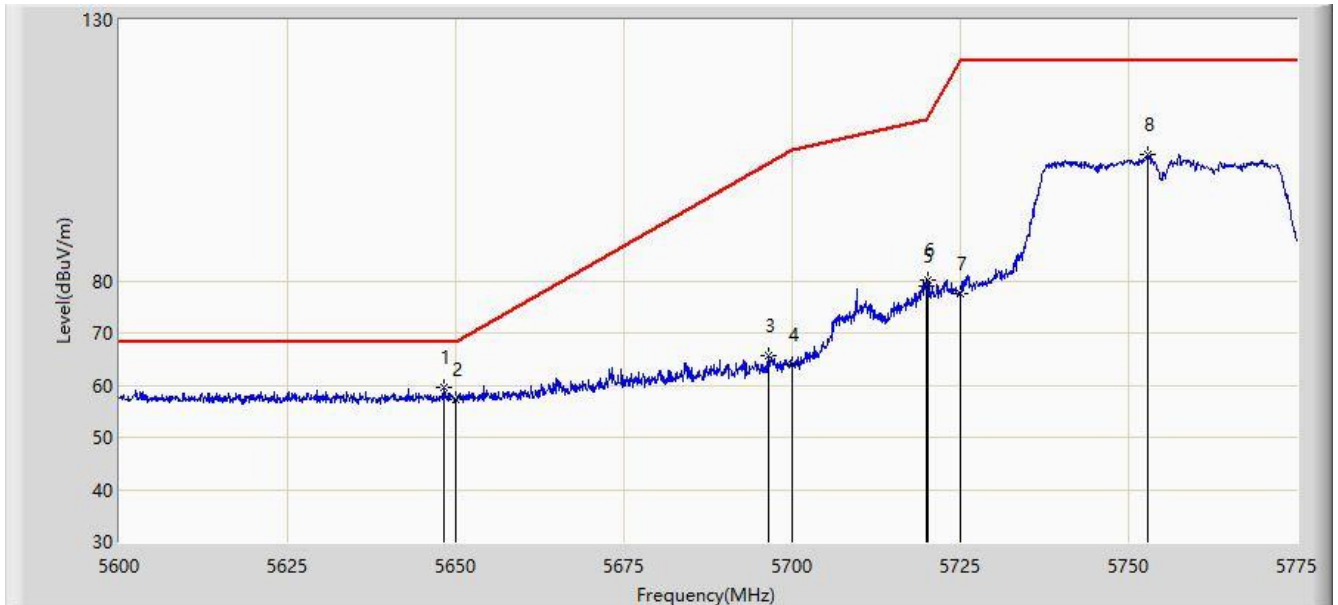

No	Flag	Mark	Frequency (MHz)	Measure Level (dBuV/m)	Reading Level (dBuV)	Over Limit (dB)	Limit (dBuV/m)	Factor (dB)	Type
1		*	5648.212	59.433	52.460	-8.767	68.200	6.973	PK
2			5650.000	57.268	50.285	-10.932	68.200	6.983	PK
3			5696.600	65.652	58.679	-37.042	102.694	6.973	PK
4			5700.000	64.011	57.033	-41.189	105.200	6.978	PK
5			5720.000	79.033	71.919	-31.767	110.800	7.114	PK
6			5720.138	80.193	73.077	-30.922	111.115	7.115	PK
7			5725.000	77.478	70.313	-44.722	122.200	7.165	PK
8			5752.862	104.200	96.793	N/A	N/A	7.407	PK

Note: Measure Level (dBuV/m) = Reading Level (dBuV) + Factor (dB)

Factor (dB) = Cable Loss (dB) + Antenna Factor (dB/m) - Pre\_Amplifier Gain (dB)

Site: AC2	Time: 2018/01/13 - 12:53
Limit: FCC_Part15.407_RE(3m)_Bandedge	Engineer: Snake Ni
Probe: BBHA9120D_1-18GHz	Polarity: Vertical
EUT: Speed Dome Camera (1080P WiFi PTZ)	Power: AC 120V/60Hz
Test Mode: Transmit by 802.11ac-VHT40 at Channel 5755MHz	

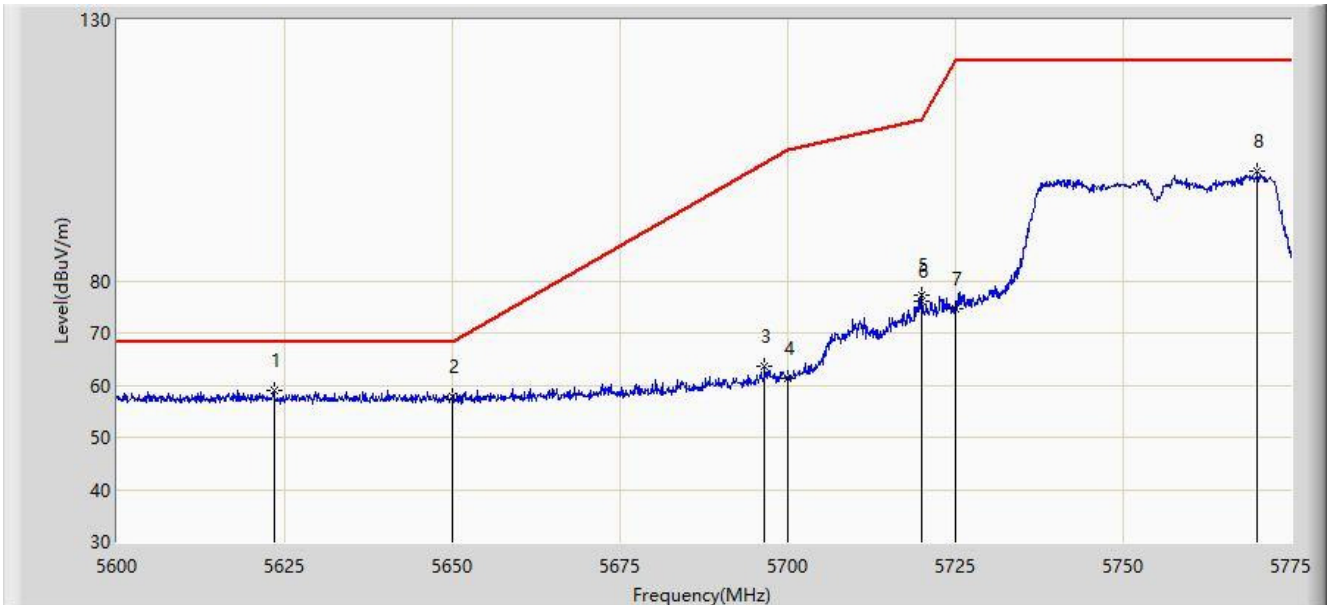

No	Flag	Mark	Frequency (MHz)	Measure Level (dBuV/m)	Reading Level (dBuV)	Over Limit (dB)	Limit (dBuV/m)	Factor (dB)	Type
1		*	5623.450	59.127	52.340	-9.073	68.200	6.786	PK
2			5650.000	57.687	50.704	-10.513	68.200	6.983	PK
3			5696.600	63.508	56.535	-39.186	102.694	6.973	PK
4			5700.000	61.441	54.463	-43.759	105.200	6.978	PK
5			5719.962	77.142	70.028	-33.648	110.789	7.114	PK
6			5720.000	76.062	68.948	-34.738	110.800	7.114	PK
7			5725.000	74.727	67.562	-47.473	122.200	7.165	PK
8			5770.013	100.882	93.442	N/A	N/A	7.440	PK

Note: Measure Level (dBuV/m) = Reading Level (dBuV) + Factor (dB)

Factor (dB) = Cable Loss (dB) + Antenna Factor (dB/m) - Pre\_Amplifier Gain (dB)

Site: AC2	Time: 2018/01/13 - 12:55
Limit: FCC_Part15.407_RE(3m)_Bandedge	Engineer: Snake Ni
Probe: BBHA9120D_1-18GHz	Polarity: Horizontal
EUT: Speed Dome Camera (1080P WiFi PTZ)	Power: AC 120V/60Hz
Test Mode: Transmit by 802.11ac-VHT40 at Channel 5795MHz	

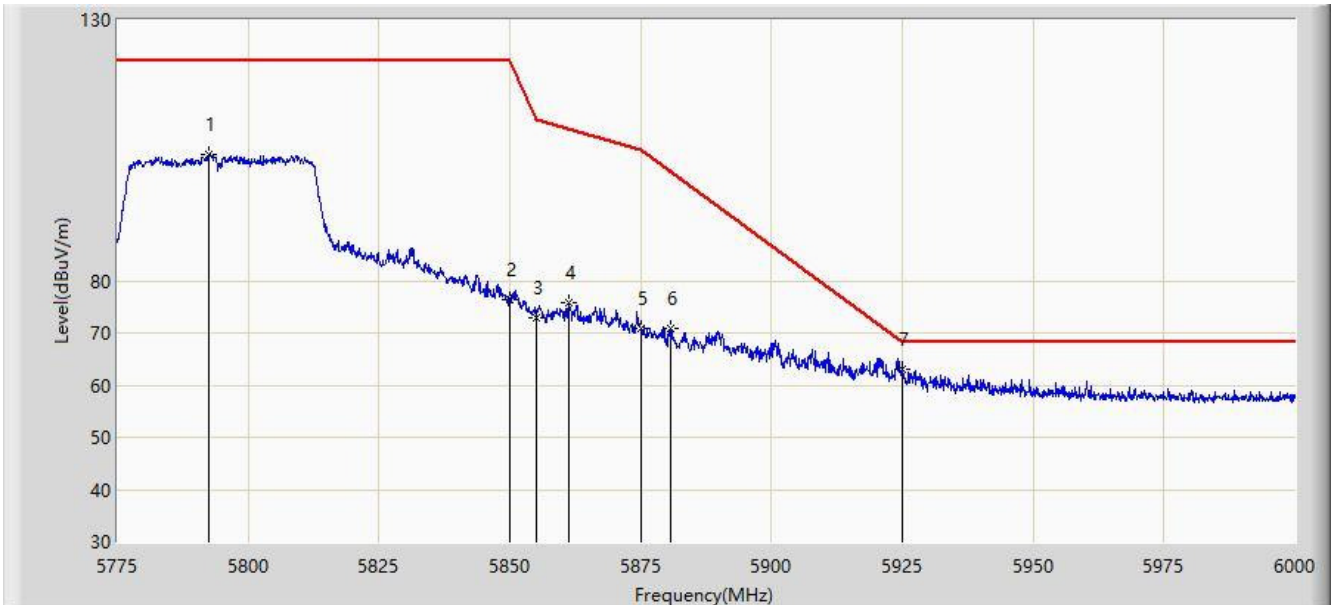

No	Flag	Mark	Frequency (MHz)	Measure Level (dBuV/m)	Reading Level (dBuV)	Over Limit (dB)	Limit (dBuV/m)	Factor (dB)	Type
1			5792.550	104.246	96.819	N/A	N/A	7.428	PK
2			5850.000	76.245	68.346	-45.955	122.200	7.899	PK
3			5855.000	72.929	65.023	-37.871	110.800	7.905	PK
4			5861.288	75.809	67.894	-33.229	109.037	7.915	PK
5			5875.000	70.979	63.071	-34.221	105.200	7.909	PK
6			5880.862	70.973	63.066	-29.873	100.846	7.907	PK
7		*	5925.000	62.969	54.936	-5.231	68.200	8.033	PK

Note: Measure Level (dBμV/m) = Reading Level (dBμV) + Factor (dB)

Factor (dB) = Cable Loss (dB) + Antenna Factor (dB/m) - Pre\_Amplifier Gain (dB)

Site: AC2	Time: 2018/01/13 - 12:57
Limit: FCC_Part15.407_RE(3m)_Bandedge	Engineer: Snake Ni
Probe: BBHA9120D_1-18GHz	Polarity: Vertical
EUT: Speed Dome Camera (1080P WiFi PTZ)	Power: AC 120V/60Hz
Test Mode: Transmit by 802.11ac-VHT40 at Channel 5795MHz	

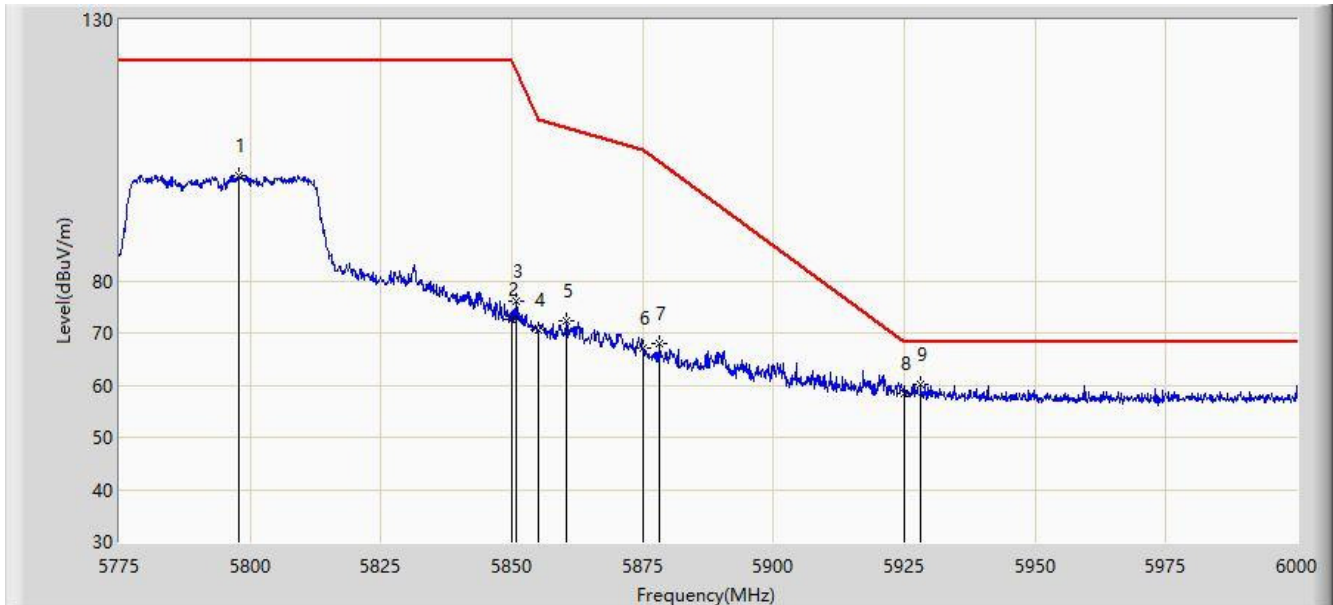

No	Flag	Mark	Frequency (MHz)	Measure Level (dBuV/m)	Reading Level (dBuV)	Over Limit (dB)	Limit (dBuV/m)	Factor (dB)	Type
1			5797.725	100.164	92.702	N/A	N/A	7.462	PK
2			5850.000	72.471	64.572	-49.729	122.200	7.899	PK
3			5850.937	76.154	68.254	-43.909	120.063	7.899	PK
4			5855.000	70.635	62.729	-40.165	110.800	7.905	PK
5			5860.500	72.303	64.389	-36.956	109.258	7.913	PK
6			5875.000	67.075	59.167	-38.125	105.200	7.909	PK
7			5878.275	67.862	59.956	-34.904	102.767	7.906	PK
8			5925.000	58.512	50.479	-9.688	68.200	8.033	PK
9		*	5928.112	60.173	52.118	-8.027	68.200	8.055	PK

Note: Measure Level (dBuV/m) = Reading Level (dBuV) + Factor (dB)

Factor (dB) = Cable Loss (dB) + Antenna Factor (dB/m) - Pre\_Amplifier Gain (dB)

Site: AC2	Time: 2018/01/13 - 13:05
Limit: FCC_Part15.209_RE(3m)	Engineer: Snake Ni
Probe: BBHA9120D_1-18GHz	Polarity: Horizontal
EUT: Speed Dome Camera (1080P WiFi PTZ)	Power: AC 120V/60Hz
Test Mode: Transmit by 802.11ac-VHT80 at Channel 5210MHz	

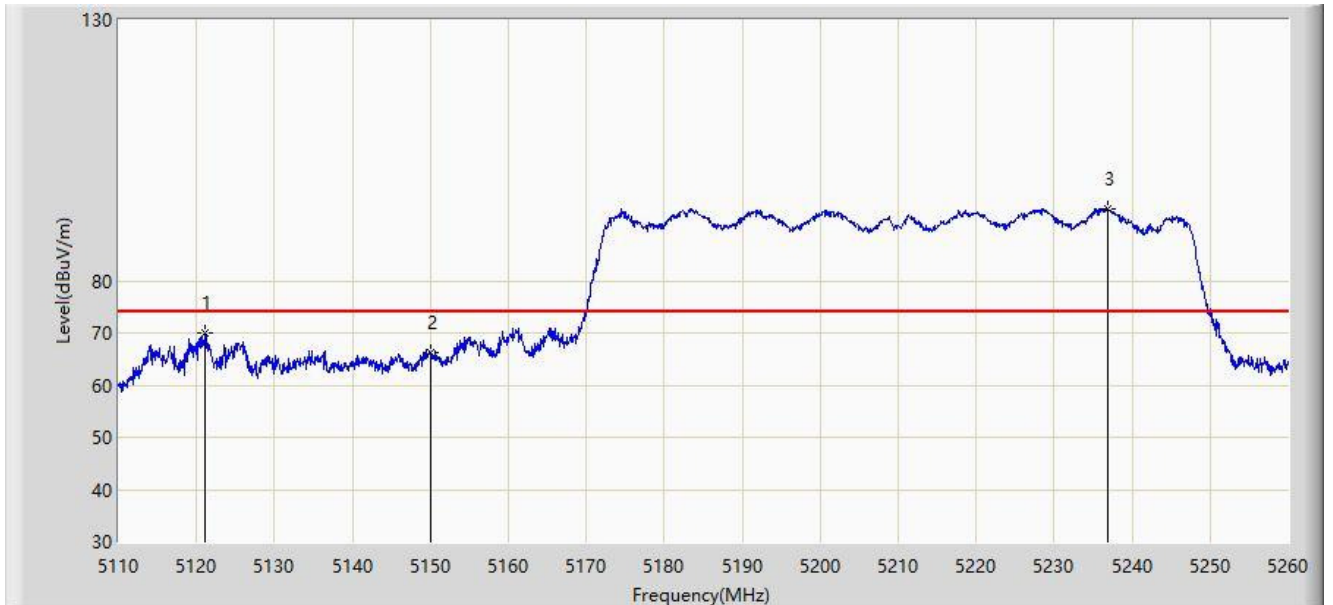

No	Flag	Mark	Frequency (MHz)	Measure Level (dBuV/m)	Reading Level (dBuV)	Over Limit (dB)	Limit (dBuV/m)	Factor (dB)	Type
1			5121.100	69.858	63.743	-4.142	74.000	6.115	PK
2			5150.000	66.233	60.110	-7.767	74.000	6.123	PK
3		*	5236.825	93.845	88.072	N/A	N/A	5.774	PK

Note: Measure Level (dBμV/m) = Reading Level (dBμV) + Factor (dB)

Factor (dB) = Cable Loss (dB) + Antenna Factor (dB/m) - Pre\_Amplifier Gain (dB)

Site: AC2	Time: 2018/01/13 - 13:02
Limit: FCC_Part15.209_RE(3m)	Engineer: Snake Ni
Probe: BBHA9120D_1-18GHz	Polarity: Horizontal
EUT: Speed Dome Camera (1080P WiFi PTZ)	Power: AC 120V/60Hz
Test Mode: Transmit by 802.11ac-VHT80 at Channel 5210MHz	

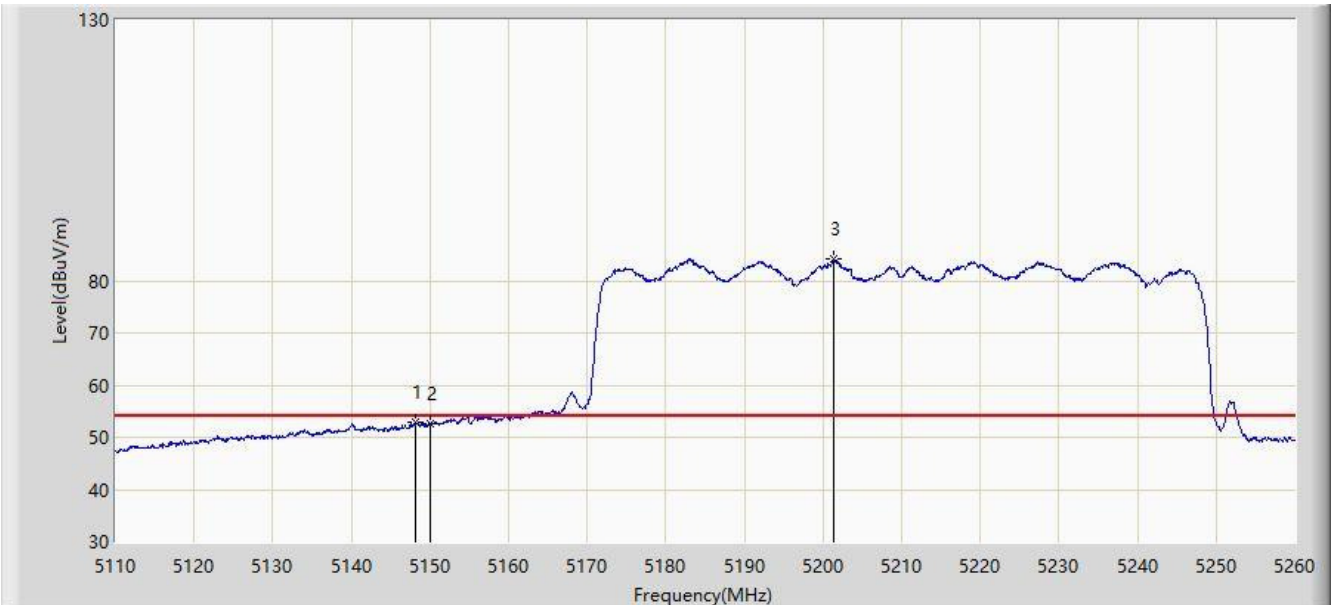

No	Flag	Mark	Frequency (MHz)	Measure Level (dBuV/m)	Reading Level (dBuV)	Over Limit (dB)	Limit (dBuV/m)	Factor (dB)	Type
1			5148.100	52.851	46.732	-1.149	54.000	6.119	AV
2			5150.000	52.507	46.384	-1.493	54.000	6.123	AV
3		*	5201.350	84.077	78.148	N/A	N/A	5.929	AV

Note: Measure Level (dBμV/m) = Reading Level (dBμV) + Factor (dB)

Factor (dB) = Cable Loss (dB) + Antenna Factor (dB/m) - Pre\_Amplifier Gain (dB)

Site: AC2	Time: 2018/01/13 - 13:06
Limit: FCC_Part15.209_RE(3m)	Engineer: Snake Ni
Probe: BBHA9120D_1-18GHz	Polarity: Vertical
EUT: Speed Dome Camera (1080P WiFi PTZ)	Power: AC 120V/60Hz
Test Mode: Transmit by 802.11ac-VHT80 at Channel 5210MHz	

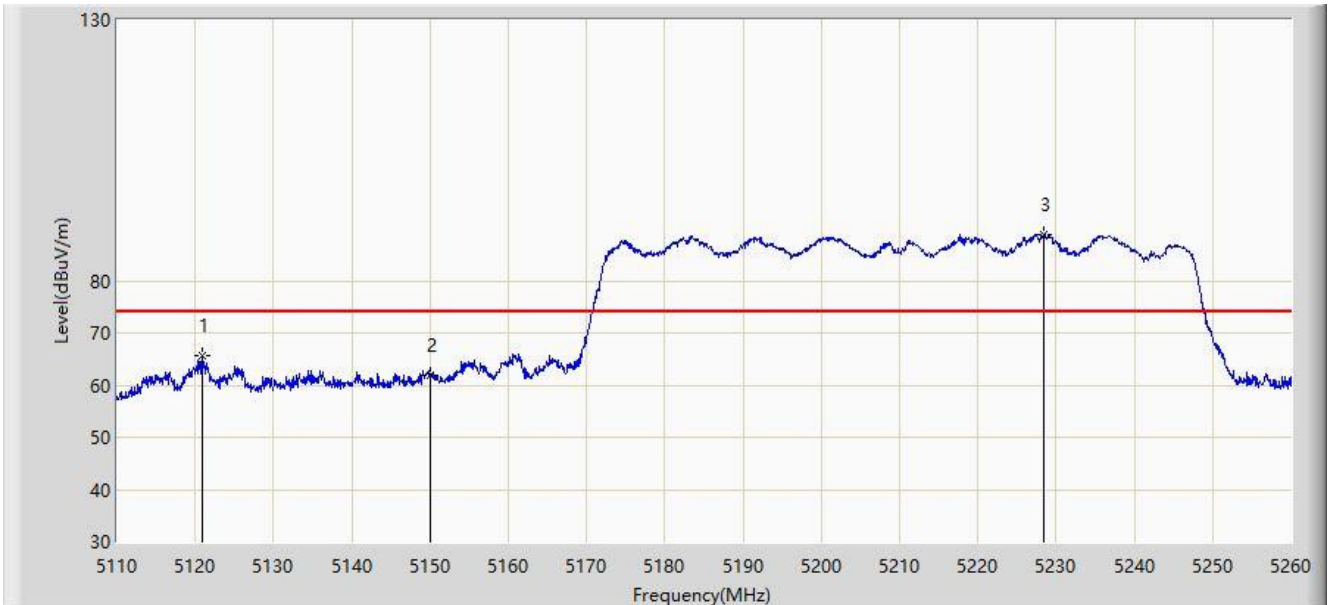

No	Flag	Mark	Frequency (MHz)	Measure Level (dBuV/m)	Reading Level (dBuV)	Over Limit (dB)	Limit (dBuV/m)	Factor (dB)	Type
1			5120.875	65.723	59.607	-8.277	74.000	6.116	PK
2			5150.000	61.893	55.770	-12.107	74.000	6.123	PK
3		*	5228.425	88.981	83.204	N/A	N/A	5.777	PK

Note: Measure Level (dBμV/m) = Reading Level (dBμV) + Factor (dB)

Factor (dB) = Cable Loss (dB) + Antenna Factor (dB/m) - Pre\_Amplifier Gain (dB)



Site: AC2	Time: 2018/01/13 - 13:07
Limit: FCC_Part15.209_RE(3m)	Engineer: Snake Ni
Probe: BBHA9120D_1-18GHz	Polarity: Vertical
EUT: Speed Dome Camera (1080P WiFi PTZ)	Power: AC 120V/60Hz
Test Mode: Transmit by 802.11ac-VHT80 at Channel 5210MHz	

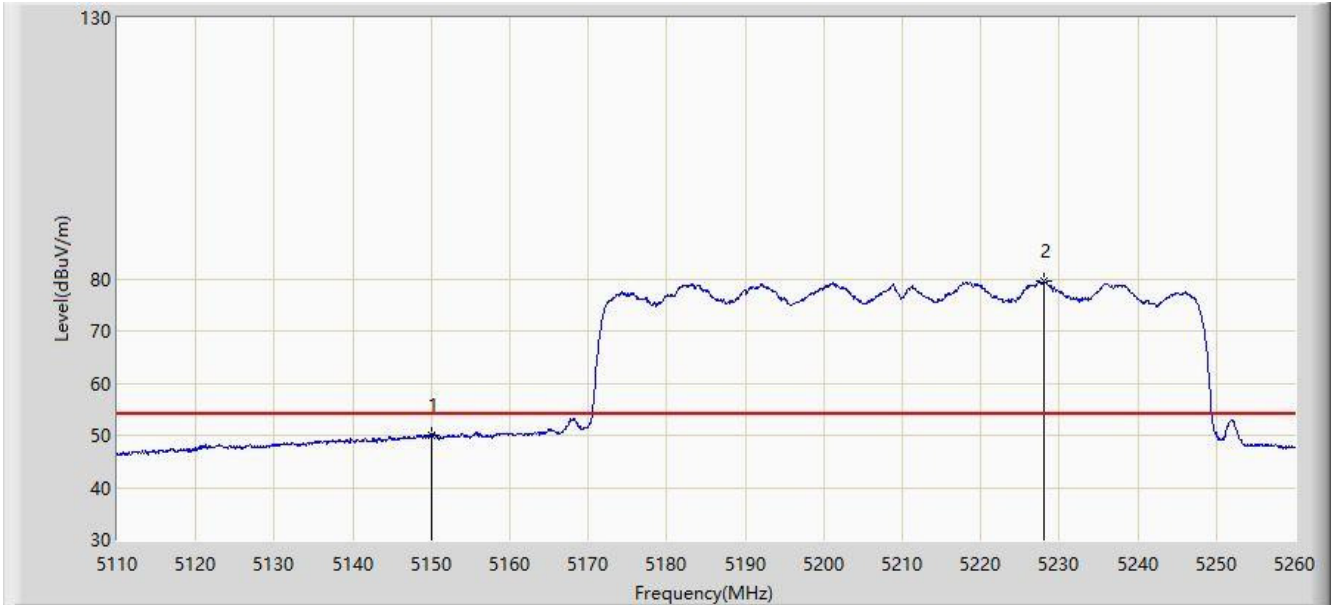

No	Flag	Mark	Frequency (MHz)	Measure Level (dBuV/m)	Reading Level (dBuV)	Over Limit (dB)	Limit (dBuV/m)	Factor (dB)	Type
1			5150.000	50.114	43.991	-3.886	54.000	6.123	AV
2		*	5227.975	79.543	73.765	N/A	N/A	5.777	AV

Note: Measure Level (dB $\mu$ V/m) = Reading Level (dB $\mu$ V) + Factor (dB)

Factor (dB) = Cable Loss (dB) + Antenna Factor (dB/m) - Pre\_Amplifier Gain (dB)

Site: AC2	Time: 2018/01/13 - 13:14
Limit: FCC_Part15.407_RE(3m)_Bandedge	Engineer: Snake Ni
Probe: BBHA9120D_1-18GHz	Polarity: Horizontal
EUT: Speed Dome Camera (1080P WiFi PTZ)	Power: AC 120V/60Hz
Test Mode: Transmit by 802.11ac-VHT80 at Channel 5775MHz	

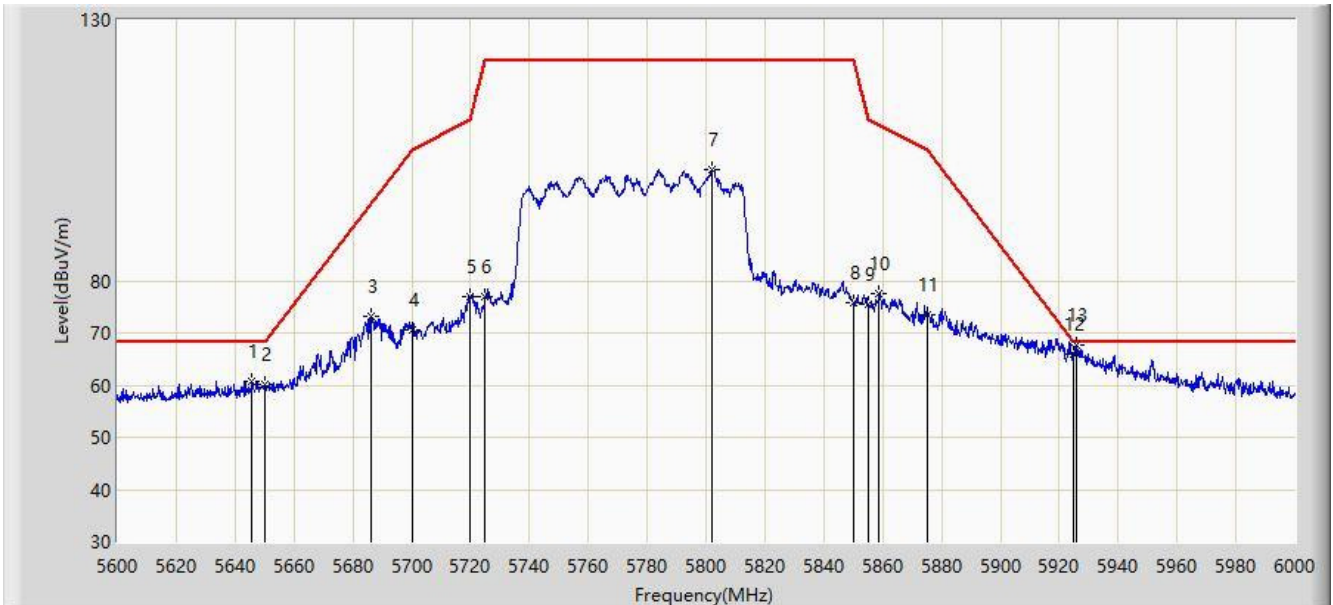

No	Flag	Mark	Frequency (MHz)	Measure Level (dBuV/m)	Reading Level (dBuV)	Over Limit (dB)	Limit (dBuV/m)	Factor (dB)	Type
1			5645.800	60.672	53.713	-7.528	68.200	6.960	PK
2			5650.000	60.196	53.213	-8.004	68.200	6.983	PK
3			5686.200	73.133	66.158	-21.887	95.021	6.976	PK
4			5700.000	70.579	63.601	-34.621	105.200	6.978	PK
5			5720.000	76.919	69.805	-33.881	110.800	7.114	PK
6			5725.000	76.966	69.801	-45.234	122.200	7.165	PK
7			5802.000	101.425	93.924	N/A	N/A	7.501	PK
8			5850.000	75.723	67.824	-46.477	122.200	7.899	PK
9			5855.000	75.572	67.666	-35.228	110.800	7.905	PK
10			5858.800	77.488	69.577	-32.246	109.735	7.911	PK
11			5875.000	73.355	65.447	-31.845	105.200	7.909	PK
12			5925.000	65.878	57.845	-2.322	68.200	8.033	PK
13		*	5925.600	67.598	59.561	-0.602	68.200	8.037	PK

Note: Measure Level (dBuV/m) = Reading Level (dBuV) + Factor (dB)

Factor (dB) = Cable Loss (dB) + Antenna Factor (dB/m) - Pre\_Amplifier Gain (dB)

Site: AC2	Time: 2018/01/13 - 13:16
Limit: FCC_Part15.407_RE(3m)_Bandedge	Engineer: Snake Ni
Probe: BBHA9120D_1-18GHz	Polarity: Vertical
EUT: Speed Dome Camera (1080P WiFi PTZ)	Power: AC 120V/60Hz
Test Mode: Transmit by 802.11ac-VHT80 at Channel 5775MHz	

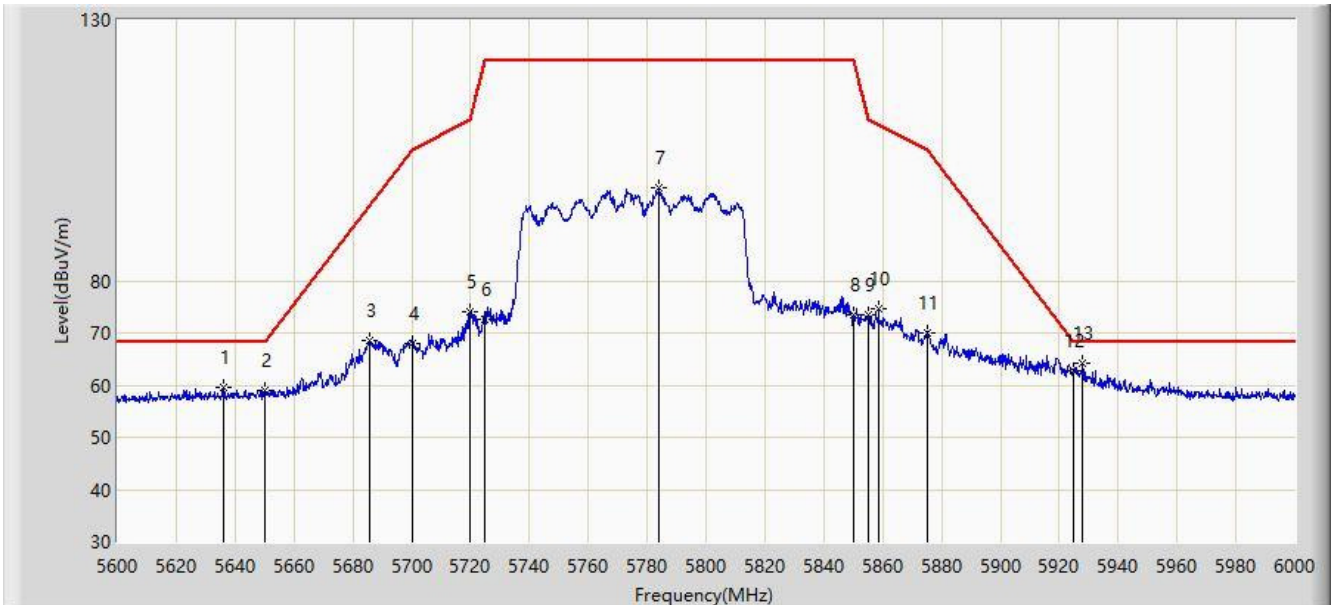

No	Flag	Mark	Frequency (MHz)	Measure Level (dBuV/m)	Reading Level (dBuV)	Over Limit (dB)	Limit (dBuV/m)	Factor (dB)	Type
1			5636.200	59.700	52.808	-8.500	68.200	6.892	PK
2			5650.000	59.068	52.085	-9.132	68.200	6.983	PK
3			5685.800	68.485	61.509	-26.240	94.725	6.976	PK
4			5700.000	67.930	60.952	-37.270	105.200	6.978	PK
5			5720.000	74.162	67.048	-36.638	110.800	7.114	PK
6			5725.000	72.483	65.318	-49.717	122.200	7.165	PK
7			5784.000	97.687	90.258	N/A	N/A	7.429	PK
8			5850.000	73.542	65.643	-48.658	122.200	7.899	PK
9			5855.000	73.335	65.429	-37.465	110.800	7.905	PK
10			5858.600	74.601	66.690	-35.190	109.791	7.912	PK
11			5875.000	69.926	62.018	-35.274	105.200	7.909	PK
12			5925.000	62.610	54.577	-5.590	68.200	8.033	PK
13		*	5928.000	64.301	56.247	-3.899	68.200	8.054	PK

Note: Measure Level (dBuV/m) = Reading Level (dBuV) + Factor (dB)

Factor (dB) = Cable Loss (dB) + Antenna Factor (dB/m) - Pre\_Amplifier Gain (dB)

## 7.9. AC Conducted Emissions Measurement

### 7.9.1. Test Limit

FCC Part 15 Subpart C Paragraph 15.207 Limits		
Frequency (MHz)	QP (dBuV)	AV (dBuV)
0.15 ~ 0.50	66 ~ 56	56 ~ 46
0.50 ~ 5.0	56	46
5.0 ~ 30	60	50

Note 1: The lower limit shall apply at the transition frequencies.

Note 2: The limit decreases linearly with the logarithm of the frequency in the range 0.15MHz to 0.5MHz.

### 7.9.2. Test Setup

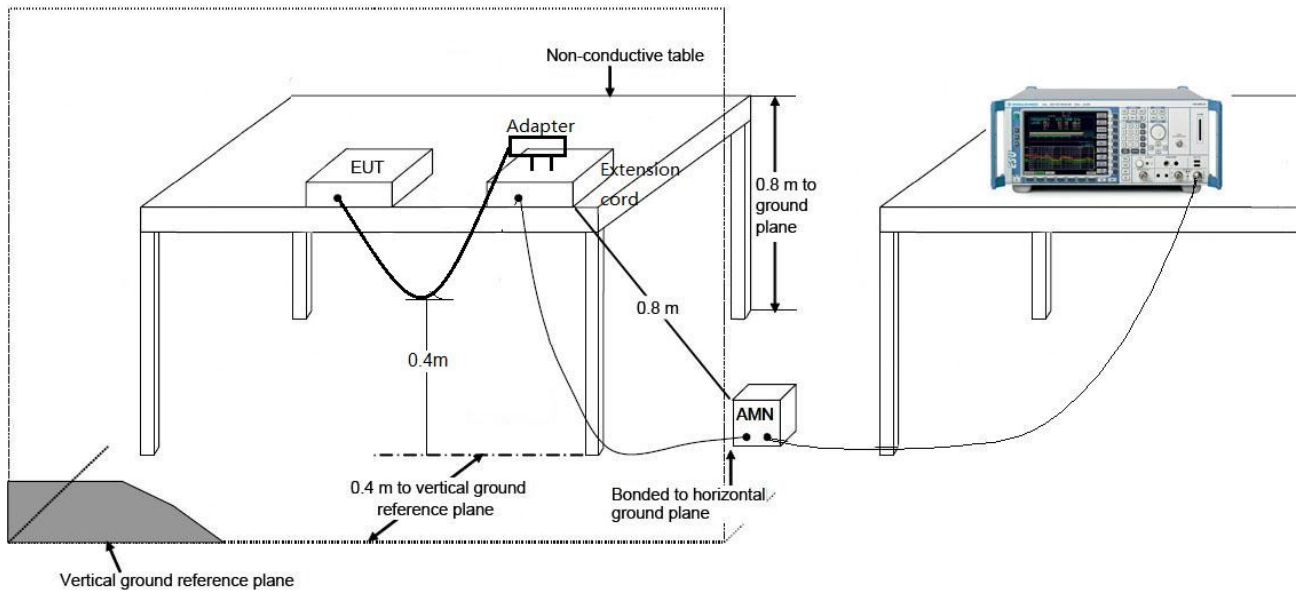

### 7.9.3. Test Result

Site: SR2	Time: 2018/01/25 - 11:45
Limit: FCC_Part15.107_CE_Class B	Engineer: Polly Zong
Probe: ENV216_101683_Filter On	Polarity: Line
EUT: Speed Dome Camera (1080P WiFi PTZ)	Power: AC 120V/60Hz
<b>Worst Case Mode:</b> Transmit by 802.11ac-VHT20 at Channel 5180MHz	

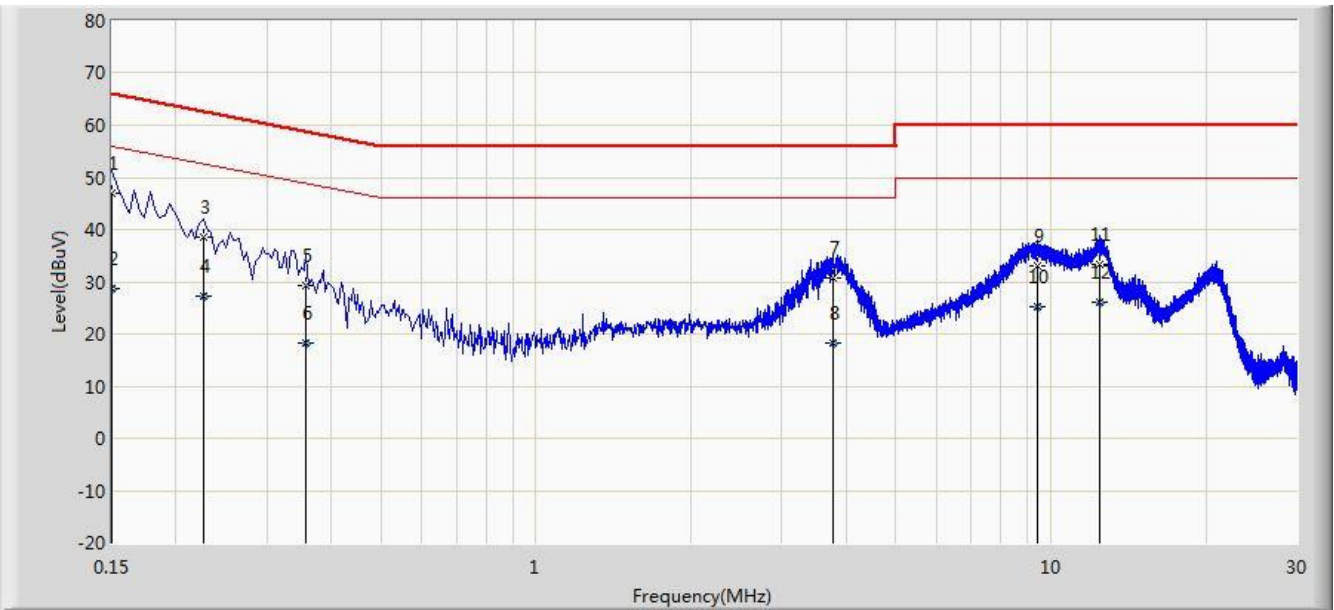

No	Flag	Mark	Frequency (MHz)	Measure Level (dBuV)	Reading Level (dBuV)	Over Limit (dB)	Limit (dBuV)	Factor (dB)	Type
1		*	0.150	46.878	35.709	-19.122	66.000	11.168	QP
2			0.150	28.761	17.593	-27.239	56.000	11.168	AV
3			0.226	38.574	28.630	-24.021	62.595	9.944	QP
4			0.226	27.307	17.363	-25.288	52.595	9.944	AV
5			0.358	29.416	19.365	-29.359	58.775	10.051	QP
6			0.358	18.282	8.231	-30.493	48.775	10.051	AV
7			3.770	30.667	20.708	-25.333	56.000	9.958	QP
8			3.770	18.236	8.277	-27.764	46.000	9.958	AV
9			9.402	32.962	22.813	-27.038	60.000	10.149	QP
10			9.402	25.302	15.153	-24.698	50.000	10.149	AV
11			12.418	33.323	23.250	-26.677	60.000	10.072	QP
12			12.418	26.181	16.108	-23.819	50.000	10.072	AV

Note: Measure Level (dBμV) = Reading Level (dBμV) + Factor (dB)

Factor (dB) = Cable Loss (dB) + LISN Factor (dB)

Site: SR2	Time: 2018/01/25 - 11:51
Limit: FCC_Part15.107_CE_Class B	Engineer: Polly Zong
Probe: ENV216_101683_Filter On	Polarity: Neutral
EUT: Speed Dome Camera (1080P WiFi PTZ)	Power: AC 120V/60Hz
<b>Worst Case Mode:</b> Transmit by 802.11ac-VHT20 at Channel 5180MHz	

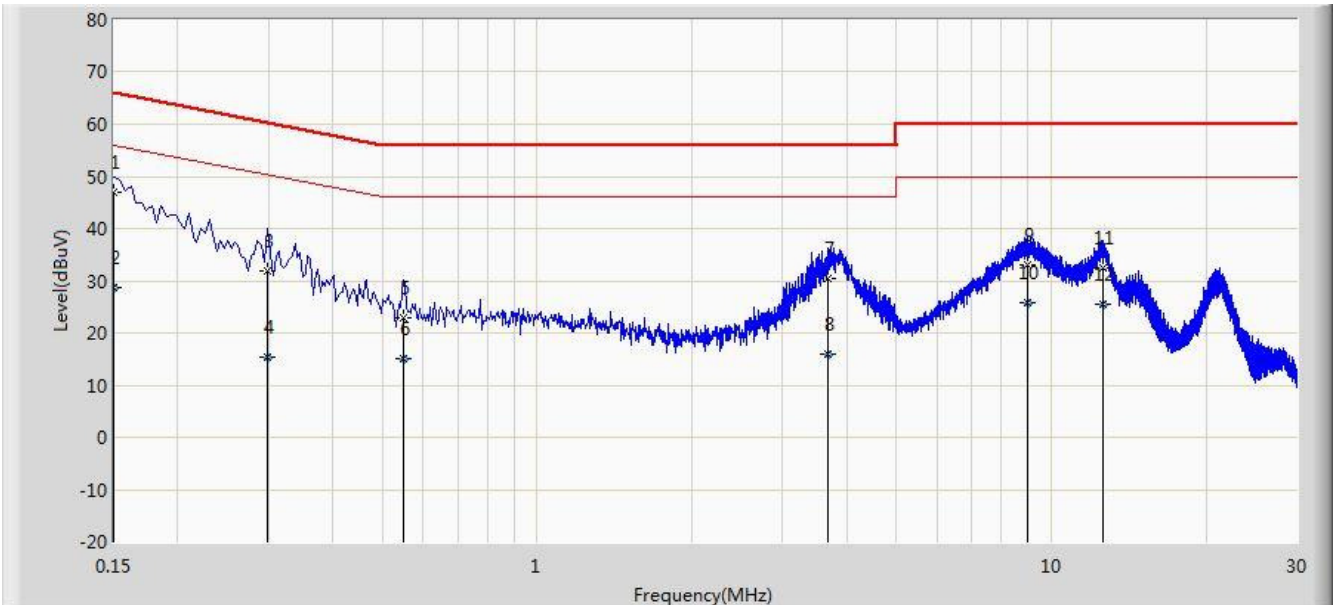

No	Flag	Mark	Frequency (MHz)	Measure Level (dBuV)	Reading Level (dBuV)	Over Limit (dB)	Limit (dBuV)	Factor (dB)	Type
1		*	0.150	47.038	35.896	-18.962	66.000	11.142	QP
2			0.150	28.794	17.652	-27.206	56.000	11.142	AV
3			0.298	31.921	21.885	-28.377	60.298	10.036	QP
4			0.298	15.427	5.391	-34.871	50.298	10.036	AV
5			0.550	22.998	12.839	-33.002	56.000	10.159	QP
6			0.550	15.079	4.921	-30.921	46.000	10.159	AV
7			3.682	30.521	20.576	-25.479	56.000	9.945	QP
8			3.682	15.979	6.034	-30.021	46.000	9.945	AV
9			8.990	33.186	23.015	-26.814	60.000	10.171	QP
10			8.990	25.810	15.639	-24.190	50.000	10.171	AV
11			12.614	32.403	22.303	-27.597	60.000	10.100	QP
12			12.614	25.637	15.537	-24.363	50.000	10.100	AV

Note: Measure Level (dBμV) = Reading Level (dBμV) + Factor (dB)

Factor (dB) = Cable Loss (dB) + LISN Factor (dB)

## 8. CONCLUSION

The data collected relate only the item(s) tested and show that the **Speed Dome Camera (1080P WiFi PTZ)** is in compliance with Part 15E of the FCC Rules and ISED Rules.

---

The End