



# FCC TEST REPORT

according to  
FCC CFR Title 47 Part 15 Subpart E(15.407)

Applicant : Amcrest Technologies LLC

---

Address : 16727 Park Row Dr.Houston, TX 77084

---

Manufacturer : Zhejiang Dahua Vision Technology Co., Ltd.

---

Address : No.1199, Bin'an Road, Binjiang District, Hangzhou, P.R. China

---

Equipment : 2K Dual Band Pan/Tilt Wireless IP Camera

---

Model No. : IP3M-941B, IP3M-941W, IP3M-941S, IP3M-941B-UK, IP3M-941W-UK,  
IP3M-941S-UK, IP3M-941B-EU, IP3M-941W-EU, IP3M-941S-EU,  
IP3M-941B-\*\*\*\*\*, IP3M-941W-\*\*\*\*\*, IP3M-941S-\*\*\*\*\*(\*\*\*\* can be "A-Z",  
or "-" or blank)

---

Brand Name : AMCREST

---

FCC ID : ZZ2AMC017

---

■ The test result refers exclusively to the test presented test model / sample.,

■ Without written approval of **CerpPASS Technology (Suzhou) Co.,Ltd.** the test report shall not be reproduced except in full.

I HEREBY CERTIFY THAT :

The measurements shown in this test report were made in accordance with the procedures given in **ANSI C63.10 – 2013** and the energy emitted by this equipment was **passed**.

**FCC Part 15** in both radiated and conducted emission class B limits. Testing was carried out on Jul 08,2016~Aug 20, 2016 at **CerpPASS Technology Corp.**

Laboratory Accreditation:

Prepared By:

Kerry Zhou

Approved by:

Miro Chueh (EMC/RF Manager)

CerpPASS Technology Corporation Test Laboratory



<b>NVLAP LAB Code:</b>	<b>200954-0</b>
<b>TAF LAB Code:</b>	<b>1439</b>

CerpPASS Technology (SuZhou) Co., Ltd.



<b>NVLAP LAB Code:</b>	<b>200814-0</b>
<b>CNAS LAB Code:</b>	<b>L5515</b>



## TABLE OF CONTENTS

<b>1. Test Configuration of Equipment under Test</b>	<b>5</b>
1.1 Feature of Equipment under Test	5
1.2 Antenna List	5
1.3 Carrier Frequency of Channels	6
1.4 Power Parameter Value of the test software	7
1.5 Duty Cycle	8
1.6 Test Manner	9
<b>2. Technical Test</b>	<b>10</b>
2.1 Summary of Test Result	10
2.2 General Information of Test	11
2.3 Measurement Uncertainty	11
<b>3. Test of Conducted Emission</b>	<b>12</b>
3.1 Test Limit	12
3.2 Test Procedures	12
3.3 Typical Test Setup	13
3.4 Measurement Equipment	13
3.5 Test Result and Data	14
<b>4. Test of Radiated Emission</b>	<b>16</b>
4.1 Test Limit	16
4.2 Test Procedures	17
4.3 Test Setting	18
4.4 Typical Test Setup	19
4.5 Measurement equipment	21
4.6 Test Result and Data	22
<b>5. Occupied Bandwidth</b>	<b>79</b>
5.1 Test Equipment	79
5.2 Test Setup	79
5.3 Test Limit	79
5.4 Test Procedure	80
5.5 Test Result and Data	81
<b>6. 6dB Bandwidth Measurement</b>	<b>90</b>
6.1 Test Equipment	90
6.2 Test Limit	90
6.3 Test Procedure used	90
6.4 Test Setting	90
6.5 Test Setup	91
6.6 Test Result	92
<b>7. Power Output</b>	<b>98</b>
7.1 Test Equipment	98
7.2 Test Setup	98



7.3 Limit ..... 99

7.4 Test Procedure ..... 100

7.5 Test Result ..... 101

**8. Power Spectral Density..... 104**

8.1 Test Equipment..... 104

8.2 Test Setup..... 104

8.3 Limit ..... 105

8.4 Test Procedure ..... 106

8.5 Test Result ..... 107

**9. Band Edges Measurement..... 115**

9.1 Test Limit ..... 115

9.2 Test Setup Layout..... 117

9.3 Measurement Equipment ..... 117

9.4 Measurement Data ..... 118

**10.Frequency Stability..... 184**

10.1 Test Equipment..... 184

10.2 Test Setup..... 184

10.3 Limit ..... 185

10.4 Test Procedure ..... 185

10.5 Test Result..... 186



**History of this test report**

Report No.	Version	Issue Date	Description
SEDL1607040	Rev.01	2016-08-20	Initial release



## 1. Test Configuration of Equipment under Test

### 1.1 Feature of Equipment under Test

WLAN Model	Realtek RTL8811AU-VS
Frequency Range	802.11a/n/ac(20MHz): 5180~5240MHz, 5745~5825MHz 802.11n/ac(40MHz): 5190~5230MHz, 5755~5795MHz 802.11ac(80MHz): 5210MHz, 5775MHz
Channel Number	802.11a/n/ac(20MHz) : 9 802.11n/ac(40MHz): 4 802.11ac(80MHz): 2
Type of Modulation	802.11a/n/ac: OFDM
Data Rate	802.11a:6/9/12/18/24/36/48/54 Mbps 802.11ac:up to 433.3 Mbps
Channel Control	Auto
Antenna Delivery	1*Tx + 1*Rx for 5GHz

### 1.2 Antenna List

Antenna	Manufacturer	Model No.	Peak Gain
PCB Antenna	ShenZhen VLG Wireless Technology Co.,Ltd	V1350-003-A-1	6.12dBi for 2400~2500MHz band 2.83dBi for 5150~5250MHz band 3.15dBi for 5725~5850MHz band



### 1.3 Carrier Frequency of Channels

802.11a/n/ac(20MHz) Working Frequency of Each Channel:							
Channel	Frequency	Channel	Frequency	Channel	Frequency	Channel	Frequency
36	5180 MHz	40	5200 MHz	44	5220 MHz	48	5240 MHz
149	5745 MHz	153	5765 MHz	157	5785 MHz	161	5805 MHz
165	5825 MHz	N/A	N/A	N/A	N/A	N/A	N/A
802.11n/ac(40MHz) Working Frequency of Each Channel:							
Channel	Frequency	Channel	Frequency	Channel	Frequency	Channel	Frequency
38	5190 MHz	46	5230 MHz	151	5755 MHz	159	5795 MHz
802.11ac(80MHz) Working Frequency of Each Channel:							
Channel	Frequency	Channel	Frequency	Channel	Frequency	Channel	Frequency
42	5210 MHz	155	5775MHz	N/A	N/A	N/A	N/A



1.4 Power Parameter Value of the test software

Test Mode	Test Channel	Power Setting
802.11a	5180	63
	5220	63
	5240	63
	5745	63
	5785	63
	5825	63
802.11n(20MHz)	5180	63
	5220	63
	5240	63
	5745	63
	5785	63
	5825	63
802.11ac(20MHz)	5180	63
	5220	63
	5240	63
	5745	63
	5785	63
	5825	63
802.11ac(40MHz)	5190	63
	5230	63
	5755	63
	5795	63
802.11ac(40MHz)	5190	63
	5230	63
	5755	63
	5795	63
802.11ac(80MHz)	5210	63
	5775	63



### 1.5 Duty Cycle

Test Mode	Frequency (MHz)	Duty Cycle
802.11a	5240	100%
802.11n(20MHz)	5240	100%
802.11ac(20MHz)	5240	100%
802.11n(40MHz)	5230	100%
802.11ac(40MHz)	5230	100%
802.11ac(80MHz)	5210	100%





### 1.6 Test Manner

Test Manner	
a	During testing, the interface cables and equipment positions were varied according to ANSI C63.10
b	Adjust the EUT at the test mode and the test channel. Then test.

Test Mode
Mode 1: Transmit by 802.11 a
Mode 2: Transmit by 802.11n (20MHz)
Mode 3: Transmit by 802.11ac (20MHz)
Mode 4: Transmit by 802.11n (40MHz)
Mode 5: Transmit by 802.11ac (40MHz)
Mode 6: Transmit by 802.11ac (80MHz)

Note: Regards to the frequency band operation: the lowest, middle and highest frequency of channel were selected to perform the test, then shown on this report.



## 2. Technical Test

### 2.1 Summary of Test Result

No deviations from the test standards

Deviations from the test standards as below description:

FCC Part Section(s)	Test Description	Test Result
15.407(a)	26dB Bandwidth	Pass
15.407(e)	6dB Bandwidth	Pass
15.407(a)(1)(ii), (2), (3)	Maximum Conducted Output Power	Pass
15.407(h)(1)	Transmit Power Control	Pass
15.407(a)(1)(ii), (2), (3), (5)	Peak Power Spectral Density	Pass
15.407(g)	Frequency Stability	Pass
15.407(b)(1), (2), (3), (4)	Undesirable Emissions	Pass
15.205, 15.209 15.407(b)(5), (6), (7)	General Field Strength Limits (Restricted Bands and Radiated Emission Limits)	Pass
15.207	AC Conducted Emissions 150kHz - 30MHz	Pass



## 2.2 General Information of Test

Test Site	CerpPASS Technology (Suzhou) Co.,Ltd
Test Site Location	No.66,Tangzhuang Road, Suzhou Industrial Park, Jiangsu 215006, China
NVLAP LAB Code	200814-0
FCC Registration Number	916572, 331395
IC Registration Number	7290A-1, 7290A-2
VCCI Registration Number	T-1945 for Telecommunication Test C-2919 for Conducted emission test R-2670 for Radiated emission test below 1GHz G-227 for Radiated emission test above 1GHz
Frequency Range Investigated	Conducted: from 150kHz to 30MHz Radiation: from 30MHz to 25000MHz
Test Distance	The test distance of radiated emission from antenna to EUT is 3 M.

## 2.3 Measurement Uncertainty

Measurement Item	Measurement Frequency	Polarization	Uncertainty
Conducted Emission	9 kHz ~ 30 MHz	LINE/NEUTRAL	$\pm 2.71$ dB
Radiated Emission	9 kHz ~ 30 MHz	Vertical	$\pm 1.60$ dB
		Horizontal	$\pm 1.60$ dB
	30 MHz ~ 25GHz	Vertical	$\pm 4.11$ dB
		Horizontal	$\pm 4.10$ dB
Occupied Bandwidth	---	---	$\pm 7500$ Hz
Maximum Peak Output Power	---	---	$\pm 1.4$ dB
Conducted Band Edges	---	---	$\pm 2.2$ dB
Power Spectral Density	---	---	$\pm 2.2$ dB



### 3. Test of Conducted Emission

#### 3.1 Test Limit

Conducted Emissions were measured from 150 kHz to 30 MHz with a bandwidth of 9 KHz on the 120 VAC power and return leads of the EUT according to the methods defined in ANSI C63.10-2013 Section 6.2. The EUT was placed on a nonmetallic stand in a shielded room 0.8 meters above the ground plane as shown in section 6.2.2. The interface cables and equipment positioning were varied within limits of reasonable applications to determine the position produced maximum conducted emissions.

Frequency (MHz)	Quasi Peak (dB $\mu$ V)	AVG (dB $\mu$ V)
0.15 – 0.5	66-56*	56-46*
0.5 – 5.0	56	46
5.0 – 30.0	60	50

\*Decreases with the logarithm of the frequency.

#### 3.2 Test Procedures

The EUT was setup according to ANSI C63.10, 2013. The EUT was placed on a platform of nominal size, 1 m by 1.5 m, raised 80 cm above the conducting ground plane. The vertical conducting plane was located 40 cm to the rear of the EUT. All other surfaces of EUT were at least 80 cm from any other grounded conducting surface. The EUT and simulators are connected to the main power through a line impedance stabilization network (LISN). The LISN provides a 50 ohm /50uH coupling impedance for the measuring equipment. The peripheral devices are also connected to the main power through a LISN. (Please refer to the block diagram of the test setup and photographs) Each current-carrying conductor of the EUT power cord, except the ground (safety) conductor, was individually connected through a LISN to the input power source. The excess length of the power cord between the EUT and the LISN receptacle were folded back and forth at the center of the lead to form a bundle not exceeding 40 cm in length. Conducted emissions were investigated over the frequency range from 0.15MHz to 30MHz using a receiver bandwidth of 9kHz.



### 3.3 Typical Test Setup

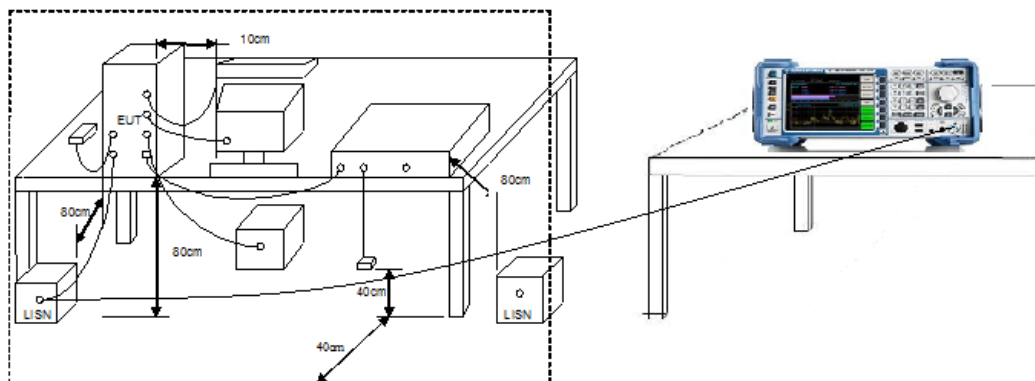

### 3.4 Measurement Equipment

Instrument	Manufacturer	Model No.	Serial No.	Calibration Date	Valid Date.
Test Receiver	R&S	ESCI	100565	2016.03.24	2017.03.23
AMN	R&S	ESH2-Z5	100182	2015.09.04	2016.09.03
Two-Line V-Network	R&S	ENV216	100325	2015.12.04	2016.12.03
ISN	FCC	FCC-TLISN-T2-02	20379	2016.03.24	2017.03.23
ISN	FCC	FCC-TLISN-T4-02	20380	2016.03.24	2017.03.23
ISN	FCC	FCC-TLISN-T8-02	20381	2016.03.24	2017.03.23
ISN	TESEQ	ISN ST08	30175	2016.03.24	2017.03.23
Current Probe	R&S	EZ-17	100303	2016.04.04	2017.04.03
Passive Voltage Probe	R&S	ESH2-Z3	100026	2016.03.29	2017.03.28
Pulse Limiter	R&S	ESH3-Z2	100529	2016.03.29	2017.03.28
Temperature/ Humidity Meter	Zhicheng	ZC1-11	CEP-TH-004	2016.03.31	2017.03.30



### 3.5 Test Result and Data

Test Mode :	Mode 1: Normal Operation with wifi on		
AC Power :	AC 120V/60Hz	Phase :	LINE
Temperature :	22°C	Humidity :	50%
Pressure(mbar) :	1002	Date:	2016/08/06

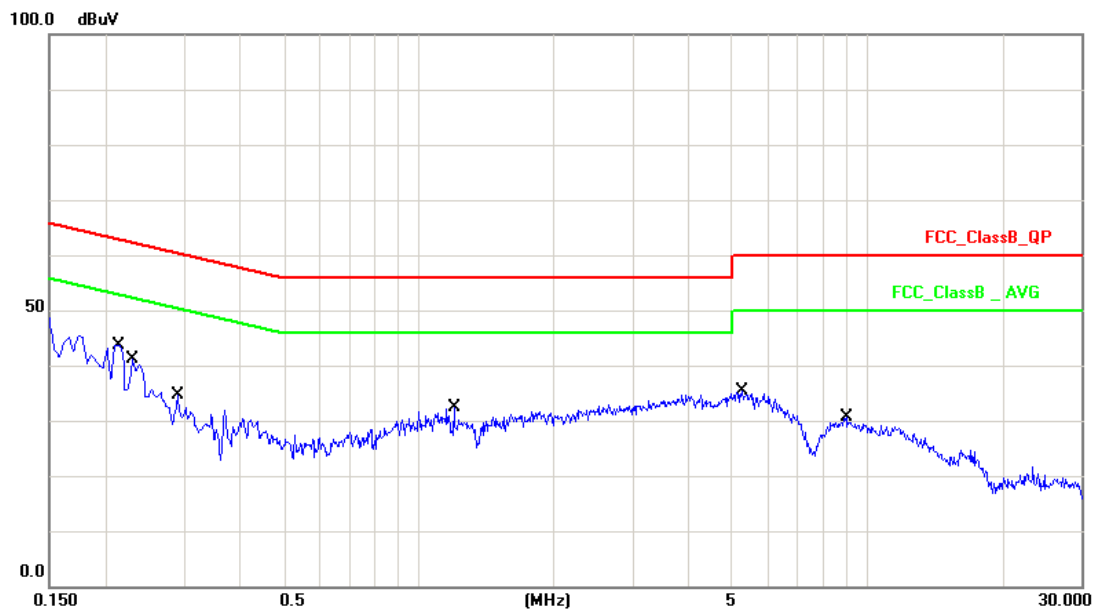

No.	Frequency (MHz)	Factor (dB)	Reading (dBuV)	Level (dBuV)	Limit (dBuV)	Margin (dB)	Detector
1	0.2140	10.12	28.51	38.63	63.04	-24.41	QP
2	0.2140	10.12	18.68	28.80	53.04	-24.24	AVG
3	0.2300	10.12	27.83	37.95	62.45	-24.50	QP
4	0.2300	10.12	21.12	31.24	52.45	-21.21	AVG
5	0.2900	10.14	20.05	30.19	60.52	-30.33	QP
6	0.2900	10.14	12.85	22.99	50.52	-27.53	AVG
7	1.1980	10.16	14.32	24.48	56.00	-31.52	QP
8	1.1980	10.16	7.89	18.05	46.00	-27.95	AVG
9	5.2500	10.24	20.81	31.05	60.00	-28.95	QP
10	5.2500	10.24	15.56	25.80	50.00	-24.20	AVG
11	8.9780	10.26	15.98	26.24	60.00	-33.76	QP
12	8.9780	10.26	11.14	21.40	50.00	-28.60	AVG

Note: Measurement Level = Reading Level + Correct Factor



Test Mode :	Mode 1: Normal Operation with wifi on		
AC Power :	AC 120V/60Hz	Phase :	NEUTRAL
Temperature :	22°C	Humidity :	50%
Pressure(mbar) :	1002	Date:	2016/08/06

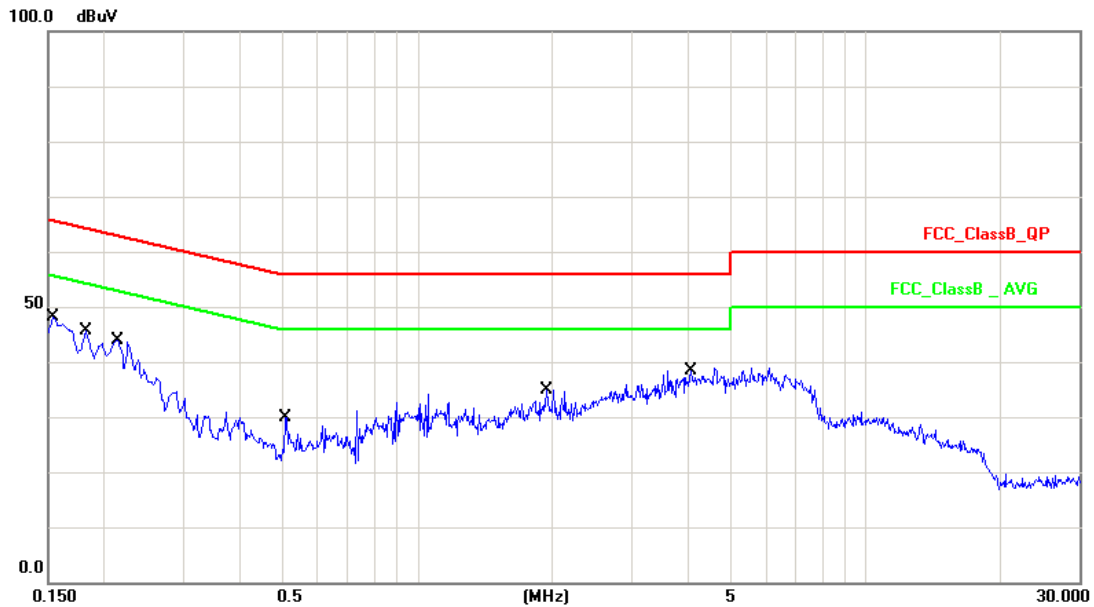

No.	Frequency (MHz)	Factor (dB)	Reading (dBuV)	Level (dBuV)	Limit (dBuV)	Margin (dB)	Detector
1	0.1540	10.13	32.64	42.77	65.78	-23.01	QP
2	0.1540	10.13	15.07	25.20	55.78	-30.58	AVG
3	0.1820	10.13	28.75	38.88	64.39	-25.51	QP
4	0.1820	10.13	14.89	25.02	54.39	-29.37	AVG
5	0.2140	10.13	29.78	39.91	63.05	-23.14	QP
6	0.2140	10.13	19.88	30.01	53.05	-23.04	AVG
7	0.5100	10.15	11.30	21.45	56.00	-34.55	QP
8	0.5100	10.15	3.99	14.14	46.00	-31.86	AVG
9	1.9460	10.18	17.35	27.53	56.00	-28.47	QP
10	1.9460	10.18	11.71	21.89	46.00	-24.11	AVG
11	4.0860	10.22	21.79	32.01	56.00	-23.99	QP
12	4.0860	10.22	15.75	25.97	46.00	-20.03	AVG

Note: Measurement Level = Reading Level + Correct Factor



## 4. Test of Radiated Emission

### 4.1 Test Limit

#### 4.1.1 Limits of radiated emission

According to §15.209(a), except as provided elsewhere in this Subpart, the emissions from an intentional radiator shall not exceed the field strength levels specified in the following table:

Frequency (MHz)	Distance Meters	Radiated ( $\mu$ V / M)	Radiated (dB $\mu$ V/ M)
30-88	3	100	40.0
88-216	3	150	43.5
216-960	3	200	46.0
Above 960	3	500	54.0

**NOTE:**

1. The lower limit shall apply at the transition frequencies.
2. Emission level (dBuV/m) = 20 log Emission level (uV/m).
3. For frequencies above 1000MHz, the field strength limits are based on average detector, however, the peak field strength of any emission shall not exceed the maximum permitted average limits, specified above by more than 20dB.

#### 4.1.2 Limits of unwanted emission out of the restricted bands

LIMIT	
Field strength at 3M (dB $\mu$ V/ M)	
PK	AV
74	54





## 4.2 Test Procedures

KDB 789033 D02v01r02-Section G

- a. The EUT was placed on a rotatable table top 0.8 meter for frequency below 1GHz and 1.5meter for frequency above 1GHz above ground.
- b. The EUT was set 3 meters from the interference receiving antenna which was mounted on the top of a variable height antenna tower.
- c. The table was rotated 360 degrees to determine the position of the highest radiation.
- d. The antenna is a broadband antenna and its height is varied between one meter and four meters above ground to find the maximum value of the field strength both horizontal polarization and vertical polarization of the antenna are set to make the measurement.
- e. For each suspected emission the EUT was arranged to its worst case and then tune the antenna tower (from 1 M to 4 M) and turn table (from 0 degree to 360 degrees) to find the maximum reading.
- f. Set the test-receiver system to Peak or CISPR quasi-peak Detect Function and specified bandwidth with Maximum Hold Mode.
- g. If the emission level of the EUT in peak mode was 3 dB lower than the limit specified, then testing will be stopped and peak values of EUT will be reported, otherwise, the emissions which do not have 3 dB margin will be repeated one by one using the quasi-peak method and reported.
- h. For testing above 1GHz, the emission level of the EUT in peak mode was 20dB lower than average limit (that means the emission level in peak mode also complies with the limit in average mode), then testing will be stopped and peak values of EUT will be reported, otherwise, the emissions will be measured in average mode again and reported.



### 4.3 Test Setting

#### Peak Measurements above 1GHz

1. Analyzer center frequency was set to the frequency of the radiated spurious emission of interest
2. RBW = 1MHz
3. VBW = 3MHz
4. Detector = peak
5. Sweep time = auto couple
6. Trace mode = max hold
7. Trace was allowed to stabilize

#### Quasi-Peak Measurements below 1GHz

1. Analyzer center frequency was set to the frequency of the radiated spurious emission of interest
2. Span was set greater than 1MHz
3. RBW = 120 kHz
4. Detector = CISPR quasi-peak
5. Sweep time = auto couple
6. Trace was allowed to stabilize

#### Average Measurements above 1GHz (Method AD)

1. Analyzer center frequency was set to the frequency of the radiated spurious emission of interest
2. RBW = 1MHz
3. VBW = 3MHz
4. Detector = power average (RMS)
5. Number of measurement points = 1001 (Number of points must be  $> 2 \times \text{span}/\text{RBW}$ )
6. Sweep time = auto
7. Trace was averaged over at 100 sweeps



#### 4.4 Typical Test Setup

9kHz~30MHz Test Setup

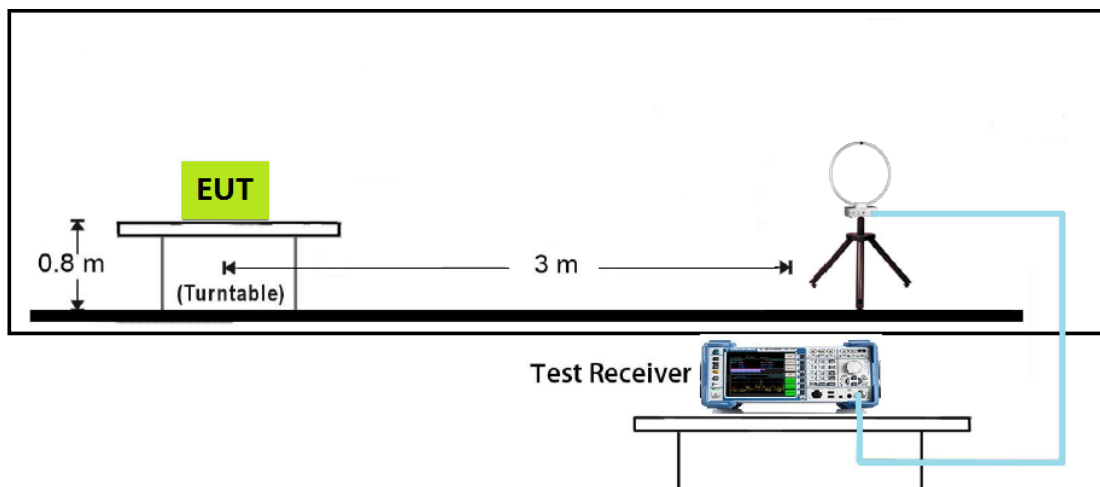



Below 1GHz Test Setup

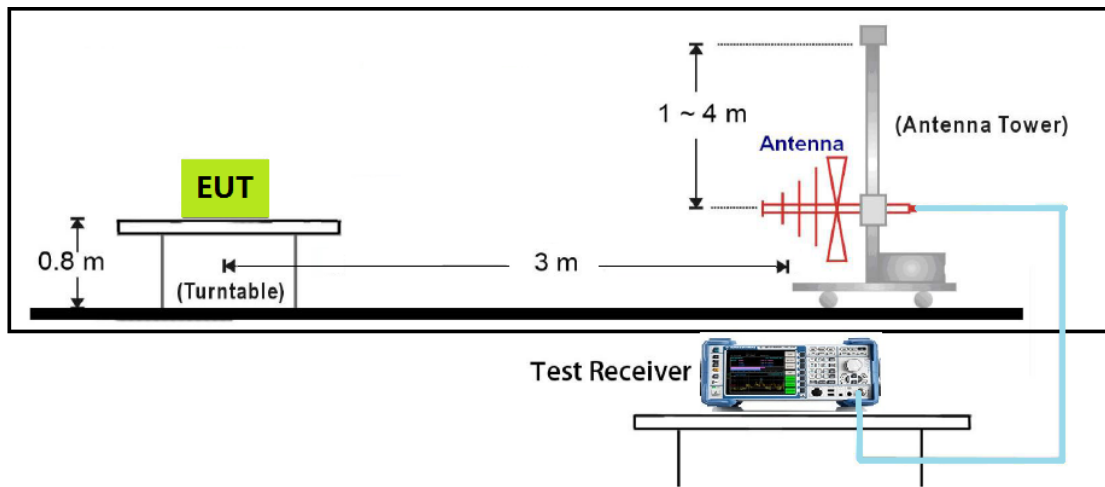

1GHz~18GHz Test Setup

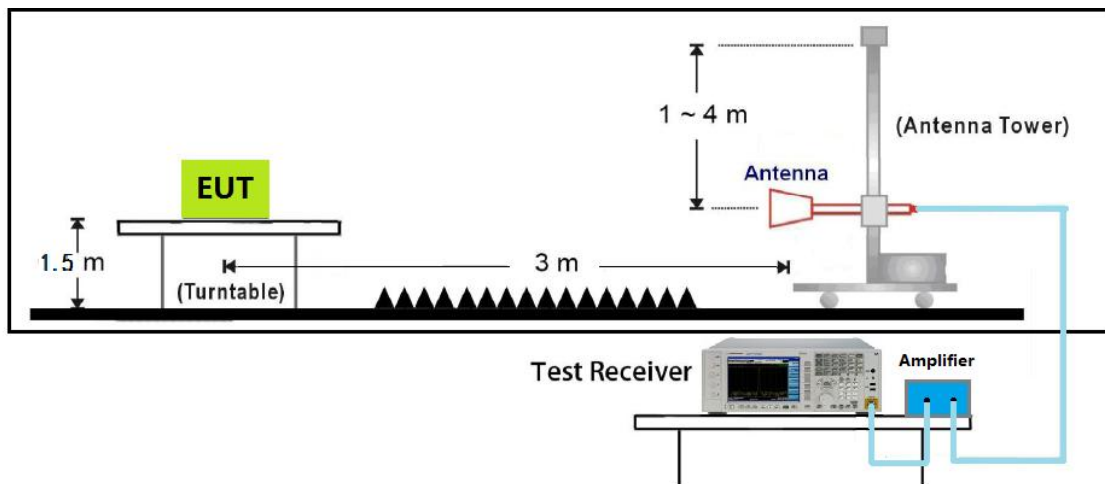

18GHz~40GHz Test Setup

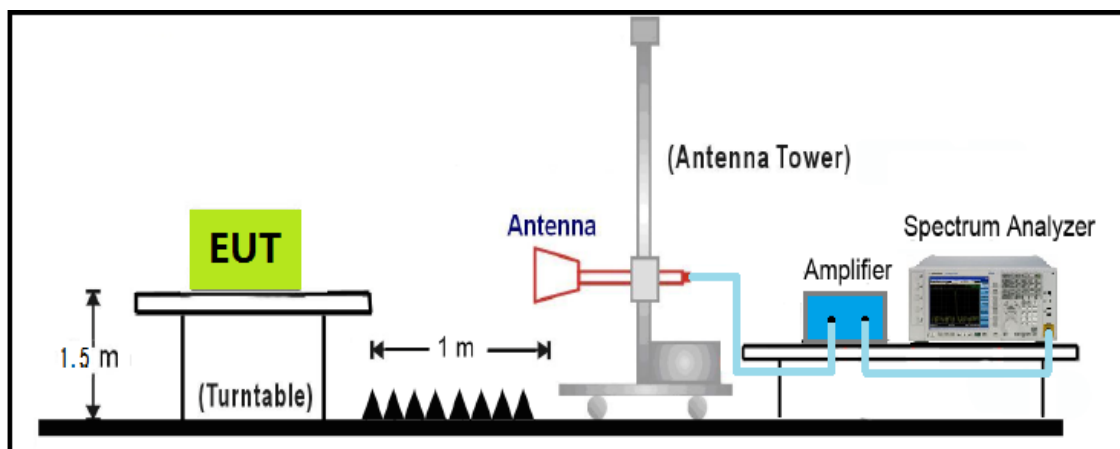

**4.5 Measurement equipment**

Instrument/Ancillary	Manufacturer	Model No.	Serial No.	Calibration Date	Valid Date.
EMI Test Receiver	R&S	ESCI	101183	2016.03.28	2017.03.29
Spectrum Analyzer	N9010A	Agilent	MY53400169	2015.11.11	2016.11.11
Spectrum Analyzer	R&S	FSP40	100324	2016.03.23	2017.03.24
H64 Preamplifier	HP	8447F	3113A05582	2016.03.24	2017.03.23
Preamplifier	songyi	EM330	60618	2016.03.29	2017.03.28
Preamplifier	Agilent	8449B	3008A02342	2016.03.29	2017.03.28
Preamplifier	COM-POWER	PA-840	711885	2016.03.29	2017.03.28
Loop Antenna	R&S	HFH2-Z2	100150	2015.09.10	2016.09.09
Bilog Antenna	Sunol Science	JB1	A072414-1	2016.04.22	2017.04.21
Broad-Band Horn Antenna	Schwarzbeck	BBHA9120D	9120D-619	2016.04.20	2017.04.19
Broad-Band Horn Antenna	Schwarzbeck	BBHA9170	9170-347	2016.04.20	2017.04.19
Temperature/ Humidity Meter	Zhicheng	ZC1-11	CEP-TH-002	2016.03.31	2017.03.30
EZ-EMC	Fala	Ver CT3A1	N/A	N/A	N/A



## 4.6 Test Result and Data

### Under 1G:

Engineer :Wind	
Site : EMC Lab AC 102	Time : 2015-06-09
Limit : FCC_CLASS_B_03M_QP	Margin : 6
EUT : VMG3925-B10A	Probe : VERTICAL/ HORIZONTAL
Power : AC 120V/60Hz	Note : Normal Link

No.	Frequency (MHz)	Factor (dB/m)	Reading (dBuV)	Level (dBuV/m)	Limit (dBuV/m)	Margin (dB)	Det.	AntPol. H/V
1	88.2000	-15.37	47.58	32.21	43.50	-11.29	QP	H
2	143.4900	-7.77	39.55	31.78	43.50	-11.72	QP	H
3	239.5200	-11.74	45.03	33.29	46.00	-12.71	QP	H
4	311.3000	-7.13	40.37	33.24	46.00	-12.76	QP	H
5	335.5500	-6.5	41.06	34.56	46.00	-11.44	QP	H
6	383.0799	-6.81	41.99	35.18	46.00	-10.82	QP	H

No.	Frequency (MHz)	Factor (dB/m)	Reading (dBuV)	Level (dBuV/m)	Limit (dBuV/m)	Margin (dB)	Det.	AntPol. H/V
1	30.9699	-2.85	31.58	28.73	40.00	-11.27	QP	V
2	71.7099	-14.06	40.36	26.3	40.00	-13.7	QP	V
3	157.0699	-7.53	39.87	32.34	43.50	-11.16	QP	V
4	287.0500	-8.73	43.25	34.52	46.00	-11.48	QP	V
5	383.0799	-6.81	41.88	35.07	46.00	-10.93	QP	V
6	720.6399	1.39	33.62	35.01	46.00	-10.99	QP	V

Note:

1. All Readings below 1GHz are Quasi-Peak, above are performed with peak and/or AVG measurements as necessary.
2. Measurement Level = Reading Level + Correct Factor



Above 1G:

Site: AC102	Time: 2016/08/10 - 15:56
Limit: FCC_Part15.209_RE(3m)	Margin: 0
Probe: BBHA 9120D(1-18GHz)	Polarity: Horizontal
EUT: IP3M-941W/941B	Power: AC 120V/60Hz
Note: Mode1: Transmit at Channel 5180MHz by 802.11a	

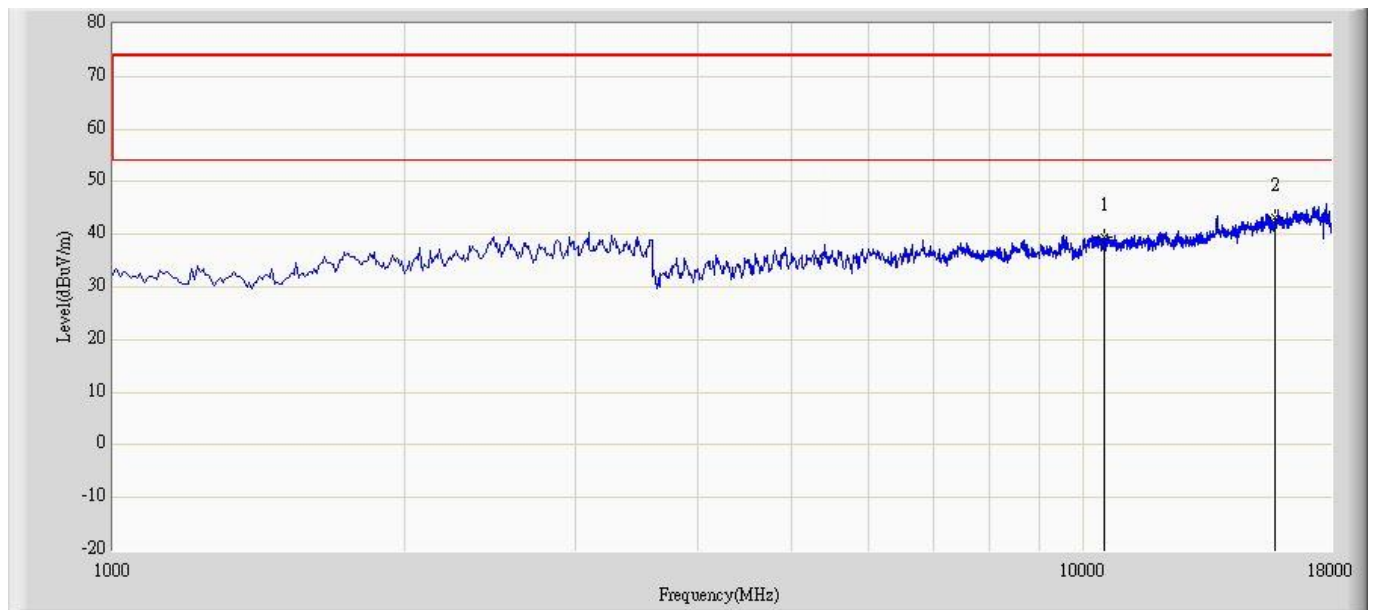

No	Flag	Mark	Frequency (MHz)	Measure Level (dBuV/m)	Reading Level (dBuV)	Over Limit (dB)	Limit (dBuV/m)	Factor	Type
1			10360.000	39.442	25.445	-34.558	74.000	13.997	PK
2		*	15540.000	43.151	20.185	-30.849	74.000	22.966	PK

Note: Measure Level (dBuV/m) = Reading Level (dBuV) + Factor (dB)

Factor (dB) = Cable Loss (dB) + Antenna Factor (dB/m) - Pre\_Amplifier Gain (dB)



Site: AC102	Time: 2016/08/10 - 15:56
Limit: FCC_Part15.209_RE(3m)	Margin: 0
Probe: BBHA 9120D(1-18GHz)	Polarity: Vertical
EUT: IP3M-941W/941B	Power: AC 120V/60Hz
Note: Mode1: Transmit at Channel 5180MHz by 802.11a	

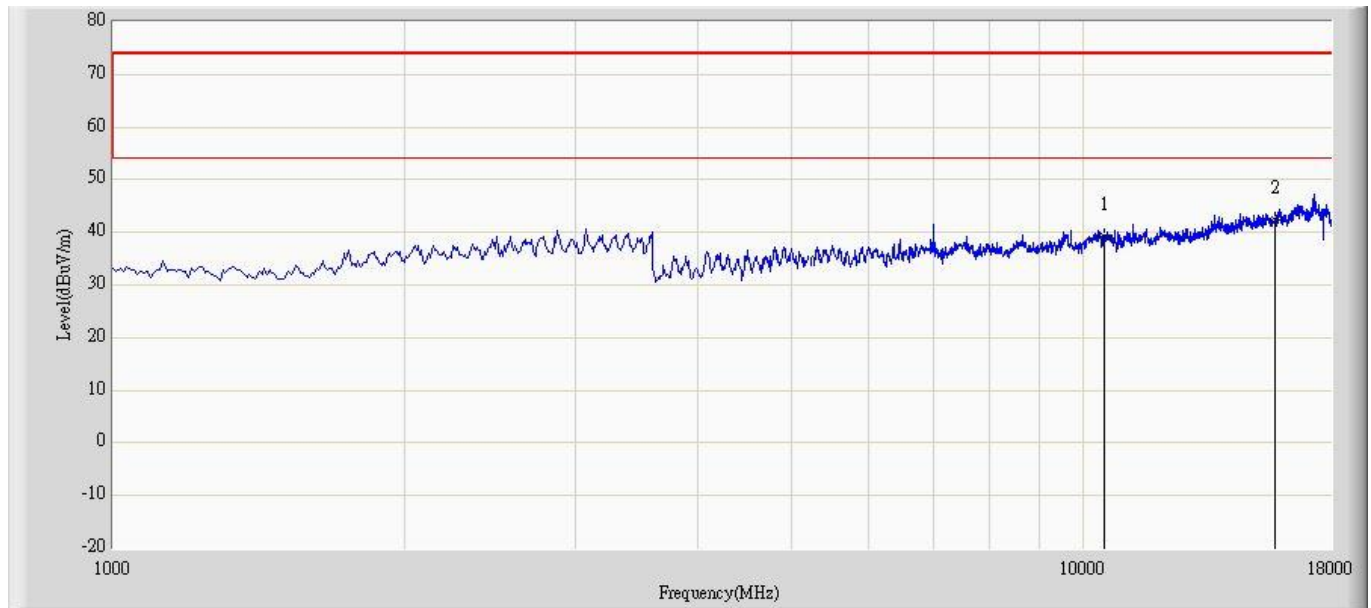

No	Flag	Mark	Frequency (MHz)	Measure Level (dBuV/m)	Reading Level (dBuV)	Over Limit (dB)	Limit (dBuV/m)	Factor	Type
1			10360.000	39.336	25.339	-34.664	74.000	13.997	PK
2		*	15540.000	42.266	19.265	-31.734	74.000	23.002	PK

Note: Measure Level (dBuV/m) = Reading Level (dBuV) + Factor (dB)

Factor (dB) = Cable Loss (dB) + Antenna Factor (dB/m) - Pre\_Amplifier Gain (dB)





Site: AC102	Time: 2016/08/10 - 15:57
Limit: FCC_Part15.209_RE(3m)	Margin: 0
Probe: BBHA 9120D(1-18GHz)	Polarity: Horizontal
EUT: IP3M-941W/941B	Power: AC 120V/60Hz
Note: Mode1: Transmit at Channel 5220MHz by 802.11a	

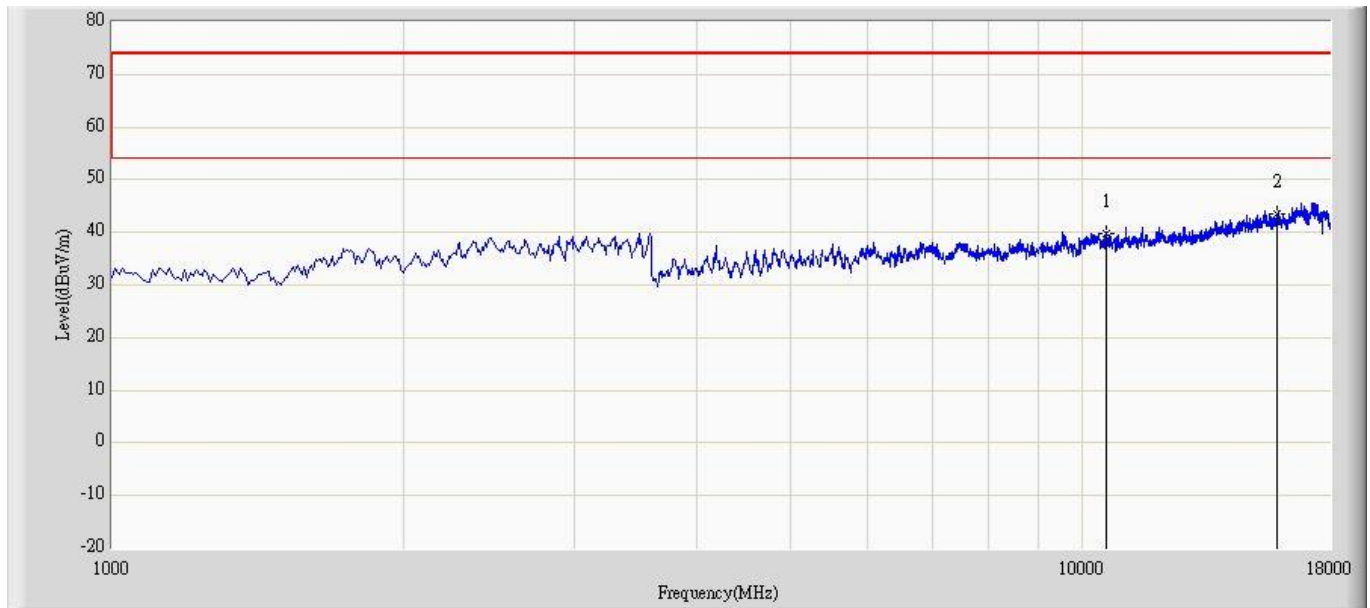

No	Flag	Mark	Frequency (MHz)	Measure Level (dBuV/m)	Reading Level (dBuV)	Over Limit (dB)	Limit (dBuV/m)	Factor	Type
1			10440.000	39.732	25.663	-34.268	74.000	14.069	PK
2		*	15660.000	43.436	20.322	-30.564	74.000	23.114	PK

Note: Measure Level (dBuV/m) = Reading Level (dBuV) + Factor (dB)

Factor (dB) = Cable Loss (dB) + Antenna Factor (dB/m) - Pre\_Amplifier Gain (dB)



Site: AC102	Time: 2016/08/10 - 15:58
Limit: FCC_Part15.209_RE(3m)	Margin: 0
Probe: BBHA 9120D(1-18GHz)	Polarity: Vertical
EUT: IP3M-941W/941B	Power: AC 120V/60Hz
Note: Mode1: Transmit at Channel 5220MHz by 802.11a	

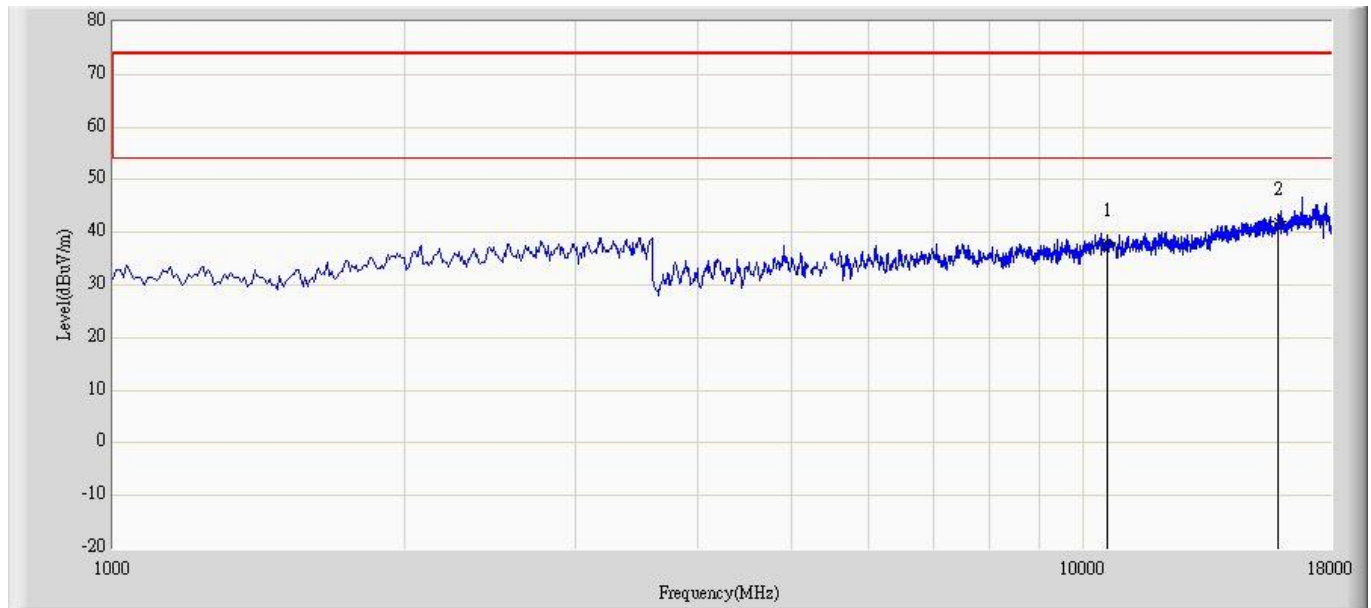

No	Flag	Mark	Frequency (MHz)	Measure Level (dBuV/m)	Reading Level (dBuV)	Over Limit (dB)	Limit (dBuV/m)	Factor	Type
1			10440.000	38.171	24.102	-35.829	74.000	14.069	PK
2		*	15660.000	42.175	18.880	-31.825	74.000	23.294	PK

Note: Measure Level (dBuV/m) = Reading Level (dBuV) + Factor (dB)

Factor (dB) = Cable Loss (dB) + Antenna Factor (dB/m) - Pre\_Amplifier Gain (dB)



Site: AC102	Time: 2016/08/10 - 15:58
Limit: FCC_Part15.209_RE(3m)	Margin: 0
Probe: BBHA 9120D(1-18GHz)	Polarity: Horizontal
EUT: IP3M-941W/941B	Power: AC 120V/60Hz
Note: Mode1: Transmit at Channel 5240MHz by 802.11a	

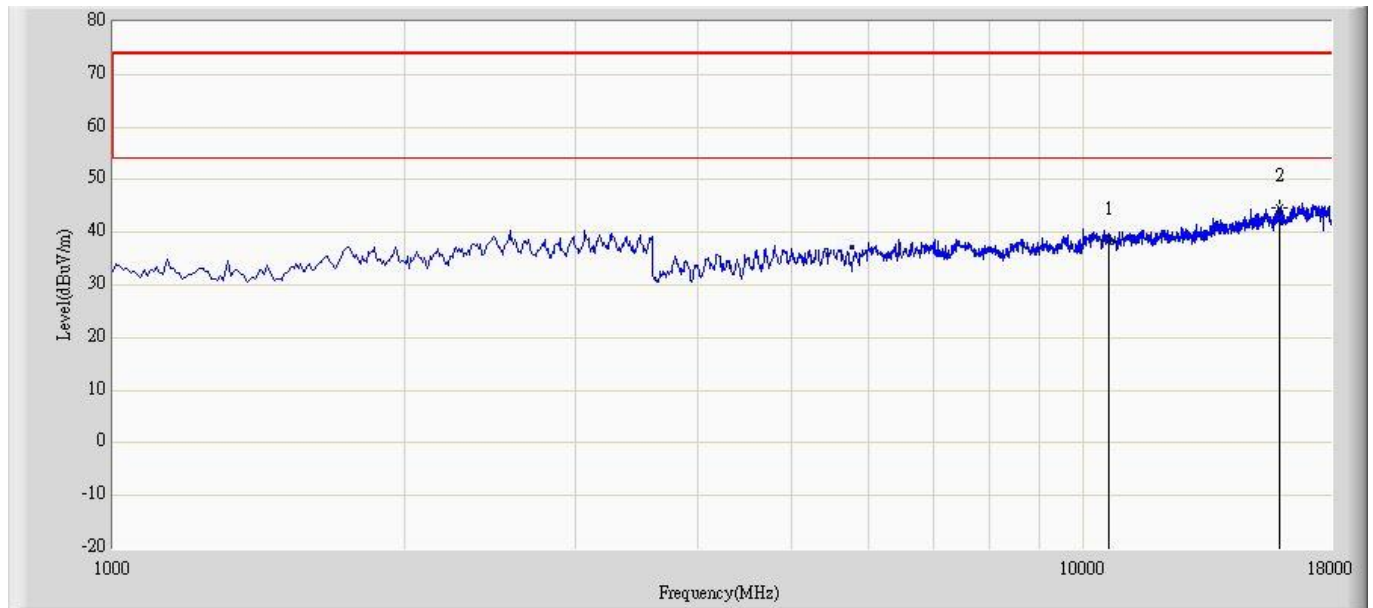

No	Flag	Mark	Frequency (MHz)	Measure Level (dBuV/m)	Reading Level (dBuV)	Over Limit (dB)	Limit (dBuV/m)	Factor	Type
1			10480.000	38.321	24.221	-35.679	74.000	14.099	PK
2		*	15720.000	44.637	21.603	-29.363	74.000	23.034	PK

Note: Measure Level (dBuV/m) = Reading Level (dBuV) + Factor (dB)

Factor (dB) = Cable Loss (dB) + Antenna Factor (dB/m) - Pre\_Amplifier Gain (dB)



Site: AC102	Time: 2016/08/10 - 15:59
Limit: FCC_Part15.209_RE(3m)	Margin: 0
Probe: BBHA 9120D(1-18GHz)	Polarity: Vertical
EUT: IP3M-941W/941B	Power: AC 120V/60Hz
Note: Mode1: Transmit at Channel 5240MHz by 802.11a	

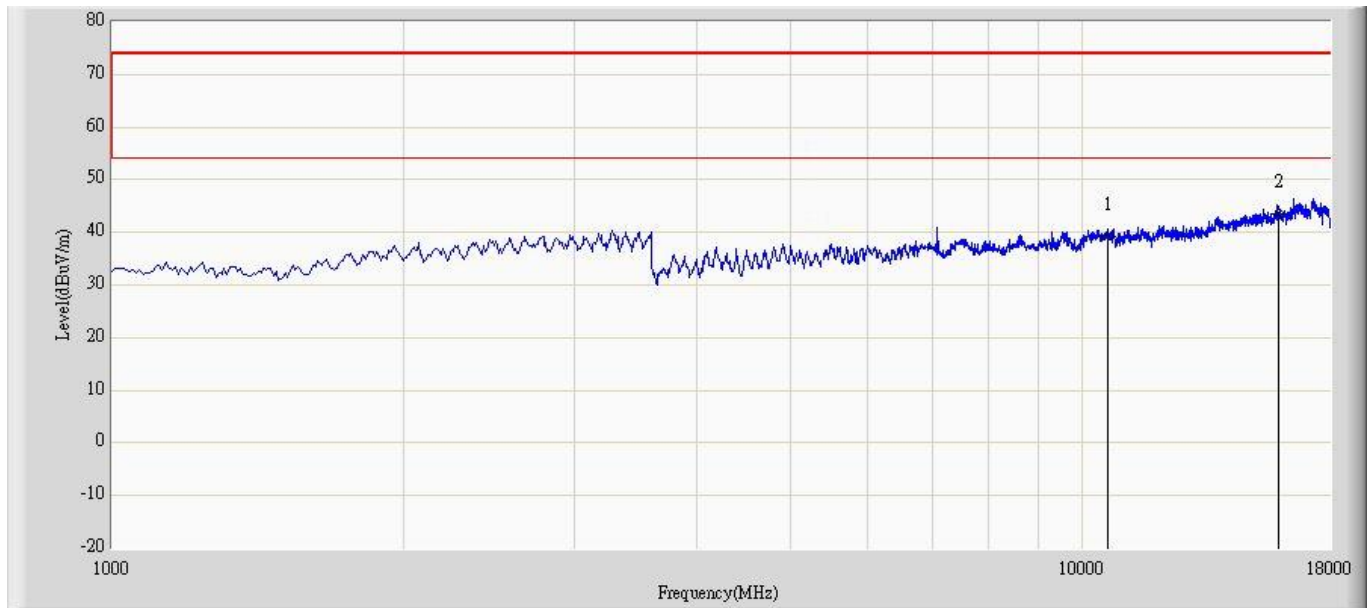

No	Flag	Mark	Frequency (MHz)	Measure Level (dBuV/m)	Reading Level (dBuV)	Over Limit (dB)	Limit (dBuV/m)	Factor	Type
1			10480.000	39.084	24.984	-34.916	74.000	14.099	PK
2		*	15720.000	43.544	20.258	-30.456	74.000	23.286	PK

Note: Measure Level (dBuV/m) = Reading Level (dBuV) + Factor (dB)

Factor (dB) = Cable Loss (dB) + Antenna Factor (dB/m) - Pre\_Amplifier Gain (dB)



Site: AC102	Time: 2016/08/10 - 16:00
Limit: FCC_Part15.209_RE(3m)	Margin: 0
Probe: BBHA 9120D(1-18GHz)	Polarity: Horizontal
EUT: IP3M-941W/941B	Power: AC 120V/60Hz
Note: Mode1: Transmit at Channel 5745MHz by 802.11a	

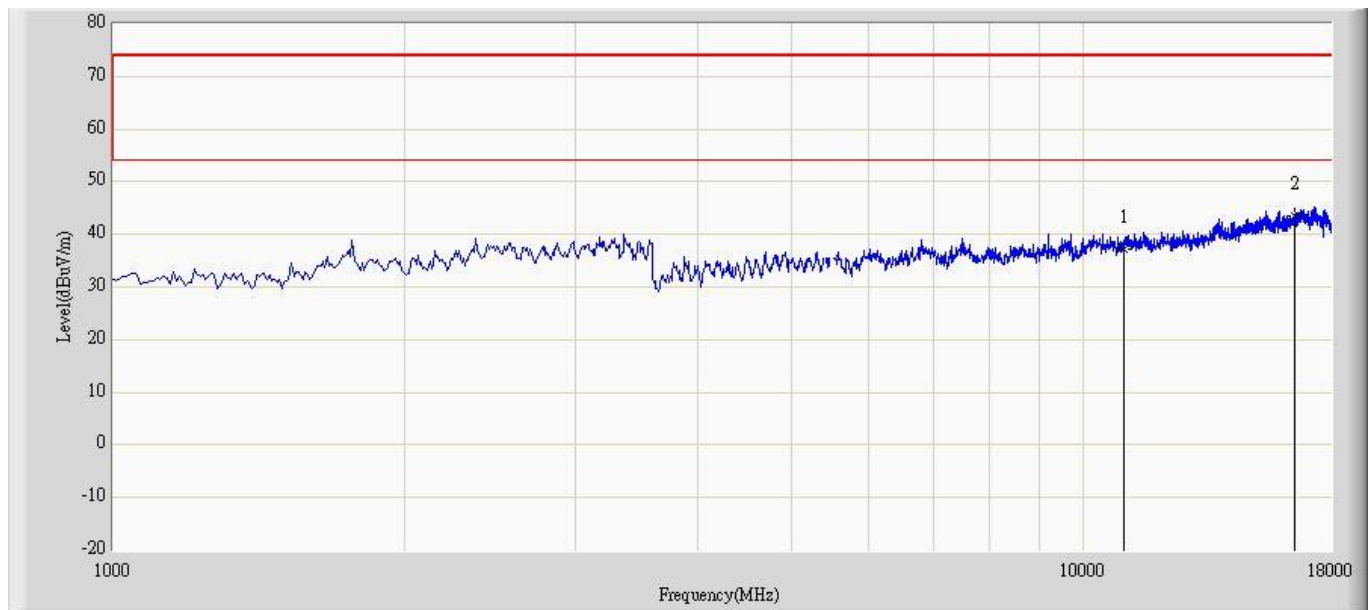

No	Flag	Mark	Frequency (MHz)	Measure Level (dBuV/m)	Reading Level (dBuV)	Over Limit (dB)	Limit (dBuV/m)	Factor	Type
1			11490.000	37.116	22.191	-36.884	74.000	14.926	PK
2		*	17235.000	43.427	21.192	-30.573	74.000	22.236	PK

Note: Measure Level (dBuV/m) = Reading Level (dBuV) + Factor (dB)

Factor (dB) = Cable Loss (dB) + Antenna Factor (dB/m) - Pre\_Amplifier Gain (dB)



Site: AC102	Time: 2016/08/10 - 16:01
Limit: FCC_Part15.209_RE(3m)	Margin: 0
Probe: BBHA 9120D(1-18GHz)	Polarity: Vertical
EUT: IP3M-941W/941B	Power: AC 120V/60Hz
Note: Mode1: Transmit at Channel 5745MHz by 802.11a	

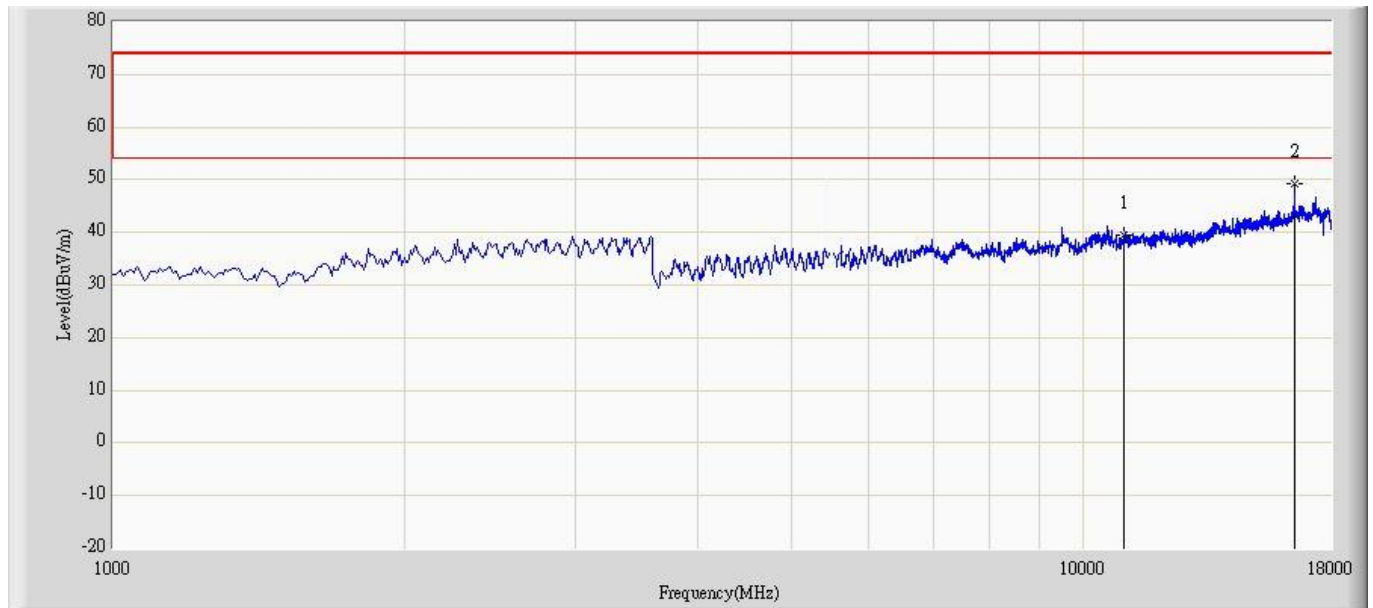

No	Flag	Mark	Frequency (MHz)	Measure Level (dBuV/m)	Reading Level (dBuV)	Over Limit (dB)	Limit (dBuV/m)	Factor	Type
1			11490.000	39.497	24.573	-34.503	74.000	14.924	PK
2		*	17235.000	49.145	26.812	-24.855	74.000	22.333	PK

Note: Measure Level (dBuV/m) = Reading Level (dBuV) + Factor (dB)

Factor (dB) = Cable Loss (dB) + Antenna Factor (dB/m) - Pre\_Amplifier Gain (dB)



Site: AC102	Time: 2016/08/10 - 16:02
Limit: FCC_Part15.209_RE(3m)	Margin: 0
Probe: BBHA 9120D(1-18GHz)	Polarity: Horizontal
EUT: IP3M-941W/941B	Power: AC 120V/60Hz
Note: Mode1: Transmit at Channel 5785MHz by 802.11a	

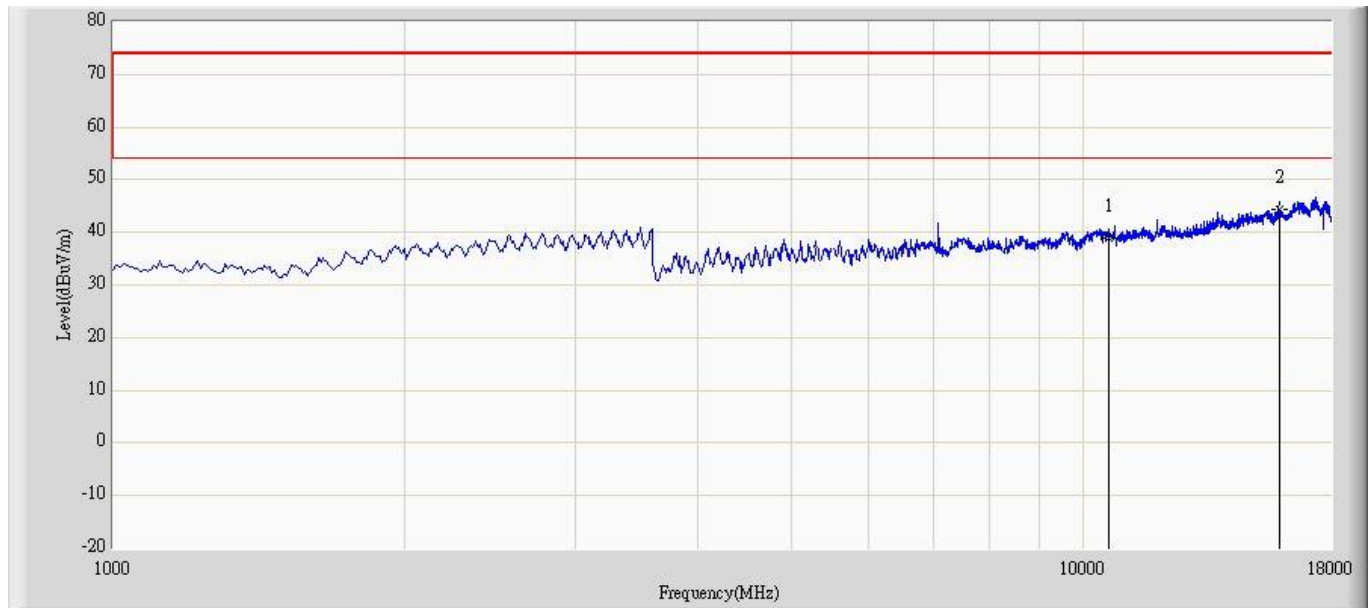

No	Flag	Mark	Frequency (MHz)	Measure Level (dBuV/m)	Reading Level (dBuV)	Over Limit (dB)	Limit (dBuV/m)	Factor	Type
1			11570.000	38.403	22.959	-35.597	74.000	15.443	PK
2		*	17355.000	42.973	20.145	-31.027	74.000	22.828	PK

Note: Measure Level (dBuV/m) = Reading Level (dBuV) + Factor (dB)

Factor (dB) = Cable Loss (dB) + Antenna Factor (dB/m) - Pre\_Amplifier Gain (dB)



Site: AC102	Time: 2016/08/10 - 16:02
Limit: FCC_Part15.209_RE(3m)	Margin: 0
Probe: BBHA 9120D(1-18GHz)	Polarity: Vertical
EUT: IP3M-941W/941B	Power: AC 120V/60Hz
Note: Mode1: Transmit at Channel 5785MHz by 802.11a	

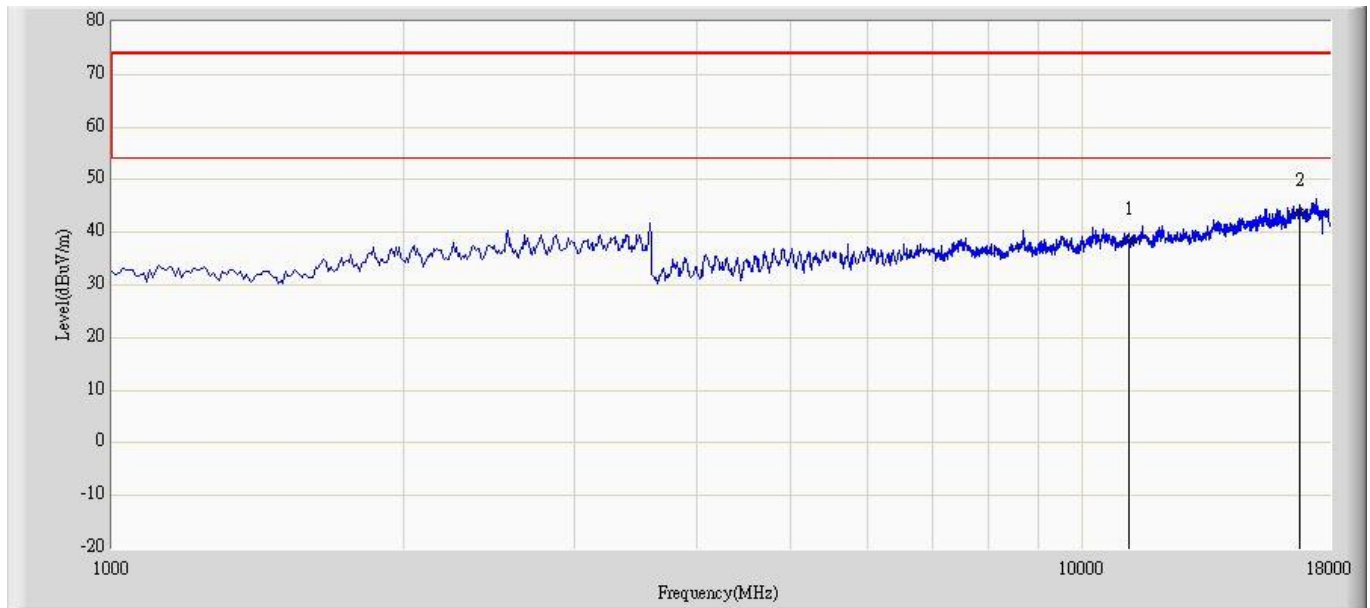

No	Flag	Mark	Frequency (MHz)	Measure Level (dBuV/m)	Reading Level (dBuV)	Over Limit (dB)	Limit (dBuV/m)	Factor	Type
1			11570.000	38.385	23.005	-35.615	74.000	15.379	PK
2		*	17355.000	43.868	20.940	-30.132	74.000	22.928	PK

Note: Measure Level (dBuV/m) = Reading Level (dBuV) + Factor (dB)

Factor (dB) = Cable Loss (dB) + Antenna Factor (dB/m) - Pre\_Amplifier Gain (dB)





Site: AC102	Time: 2016/08/10 - 16:04
Limit: FCC_Part15.209_RE(3m)	Margin: 0
Probe: BBHA 9120D(1-18GHz)	Polarity: Horizontal
EUT: IP3M-941W/941B	Power: AC 120V/60Hz
Note: Mode1: Transmit at Channel 5825MHz by 802.11a	

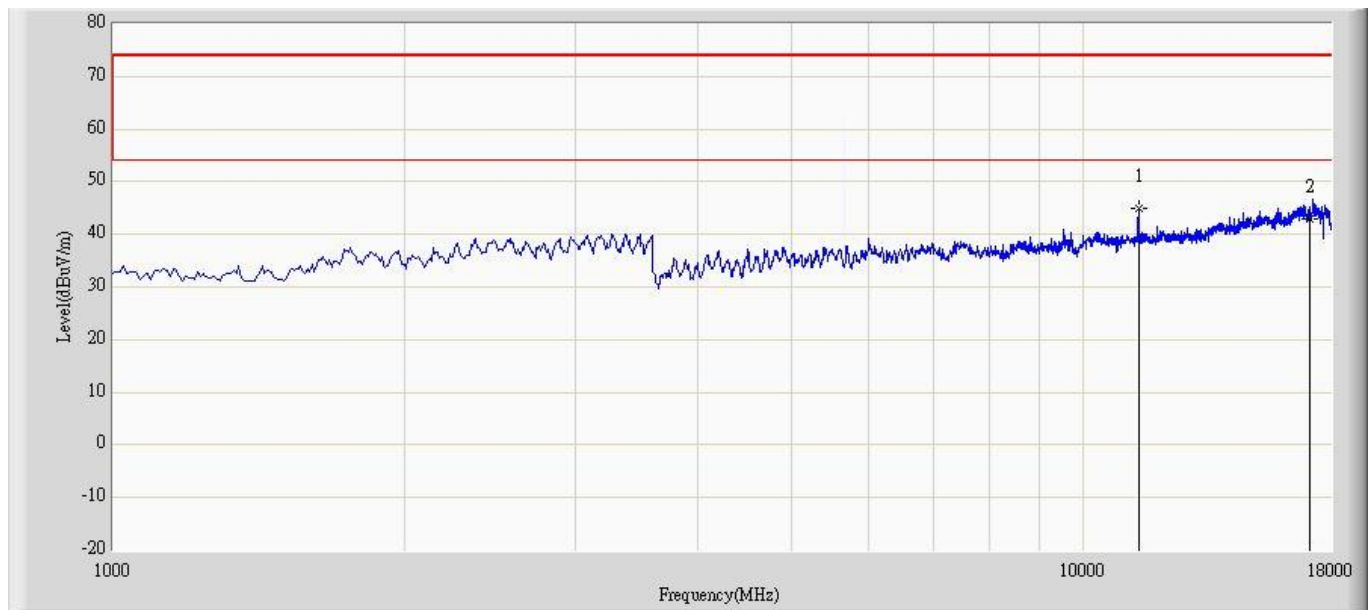

No	Flag	Mark	Frequency (MHz)	Measure Level (dBuV/m)	Reading Level (dBuV)	Over Limit (dB)	Limit (dBuV/m)	Factor	Type
1		*	11650.000	44.937	28.997	-29.063	74.000	15.939	PK
2			17475.000	43.058	19.242	-30.942	74.000	23.816	PK

Note: Measure Level (dBuV/m) = Reading Level (dBuV) + Factor (dB)

Factor (dB) = Cable Loss (dB) + Antenna Factor (dB/m) - Pre\_Amplifier Gain (dB)



Site: AC102	Time: 2016/08/10 - 16:05
Limit: FCC_Part15.209_RE(3m)	Margin: 0
Probe: BBHA 9120D(1-18GHz)	Polarity: Vertical
EUT: IP3M-941W/941B	Power: AC 120V/60Hz
Note: Mode1: Transmit at Channel 5825MHz by 802.11a	

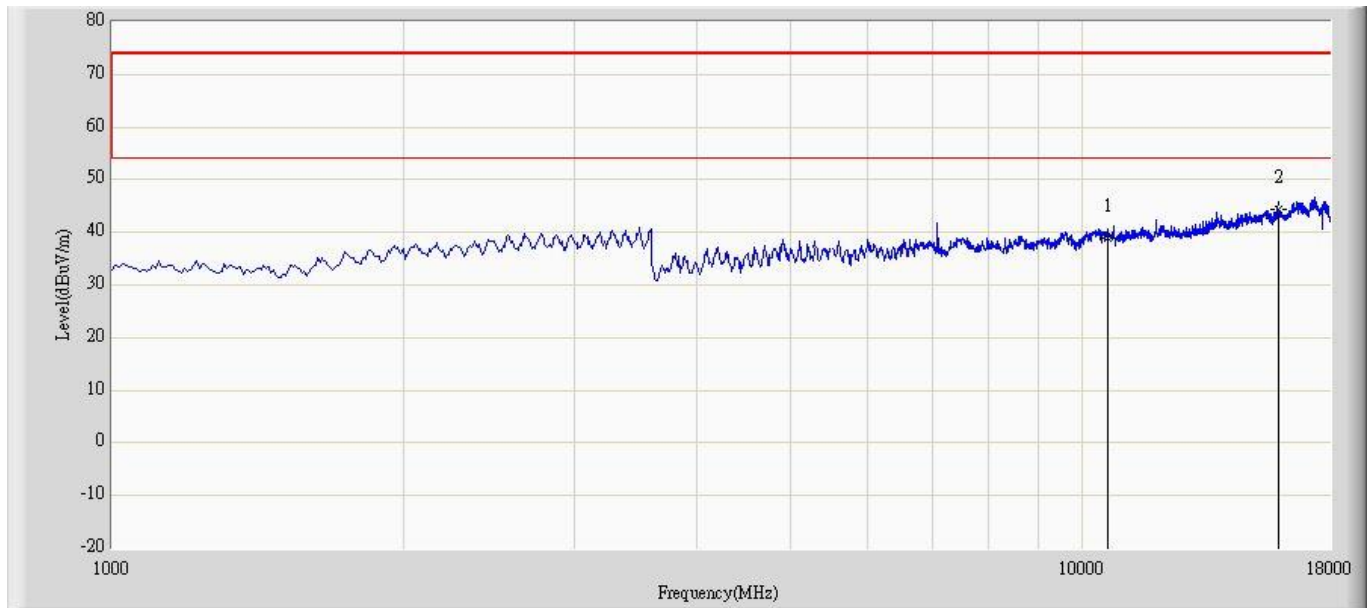

No	Flag	Mark	Frequency (MHz)	Measure Level (dBuV/m)	Reading Level (dBuV)	Over Limit (dB)	Limit (dBuV/m)	Factor (dB)	Type
1			11650.000	41.017	25.177	-32.983	74.000	15.839	PK
2		*	17475.000	47.217	23.541	-26.783	74.000	23.676	PK

Note: Measure Level (dBuV/m) = Reading Level (dBuV) + Factor (dB)

Factor (dB) = Cable Loss (dB) + Antenna Factor (dB/m) - Pre\_Amplifier Gain (dB)



Site: AC102	Time: 2016/08/10 - 16:13
Limit: FCC_Part15.209_RE(3m)	Margin: 0
Probe: BBHA 9120D(1-18GHz)	Polarity: Horizontal
EUT: IP3M-941W/941B	Power: AC 120V/60Hz
Note: Mode2: Transmit at Channel 5180MHz by 802.11n20	

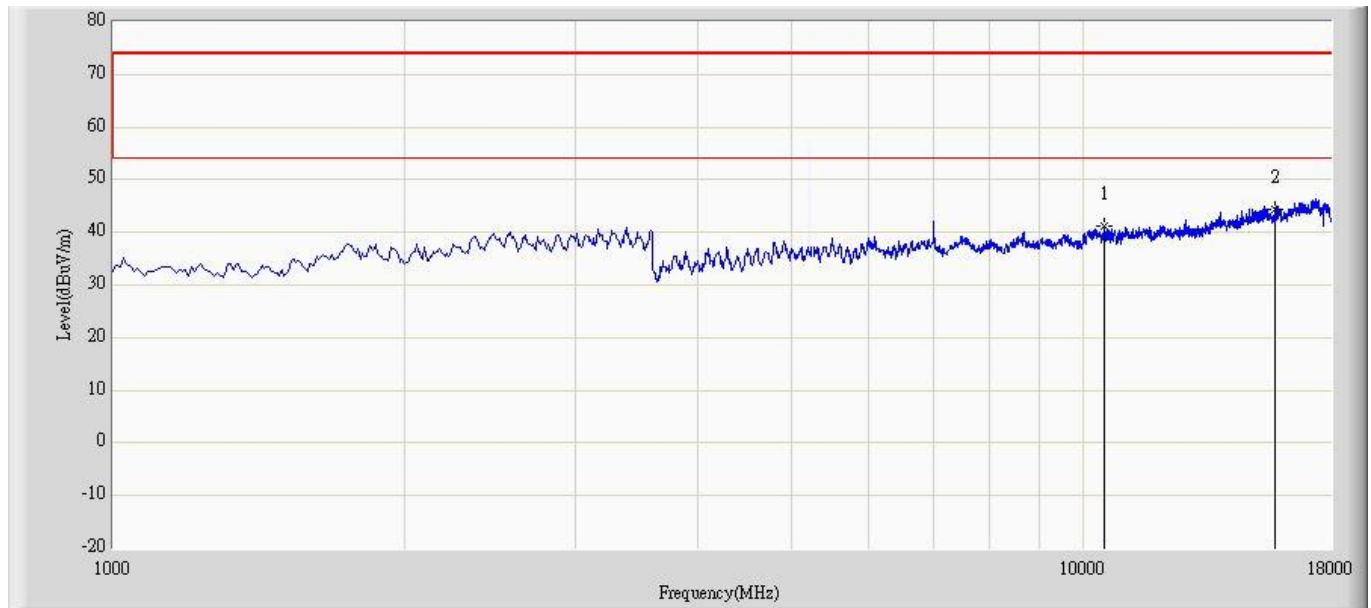

No	Flag	Mark	Frequency (MHz)	Measure Level (dBuV/m)	Reading Level (dBuV)	Over Limit (dB)	Limit (dBuV/m)	Factor	Type
1			10360.000	41.273	27.276	-32.727	74.000	13.997	PK
2		*	15540.000	44.436	21.470	-29.564	74.000	22.966	PK

Note: Measure Level (dBuV/m) = Reading Level (dBuV) + Factor (dB)

Factor (dB) = Cable Loss (dB) + Antenna Factor (dB/m) - Pre\_Amplifier Gain (dB)



Site: AC102	Time: 2016/08/10 - 16:14
Limit: FCC_Part15.209_RE(3m)	Margin: 0
Probe: BBHA 9120D(1-18GHz)	Polarity: Vertical
EUT: IP3M-941W/941B	Power: AC 120V/60Hz
Note: Mode2: Transmit at Channel 5180MHz by 802.11n20	

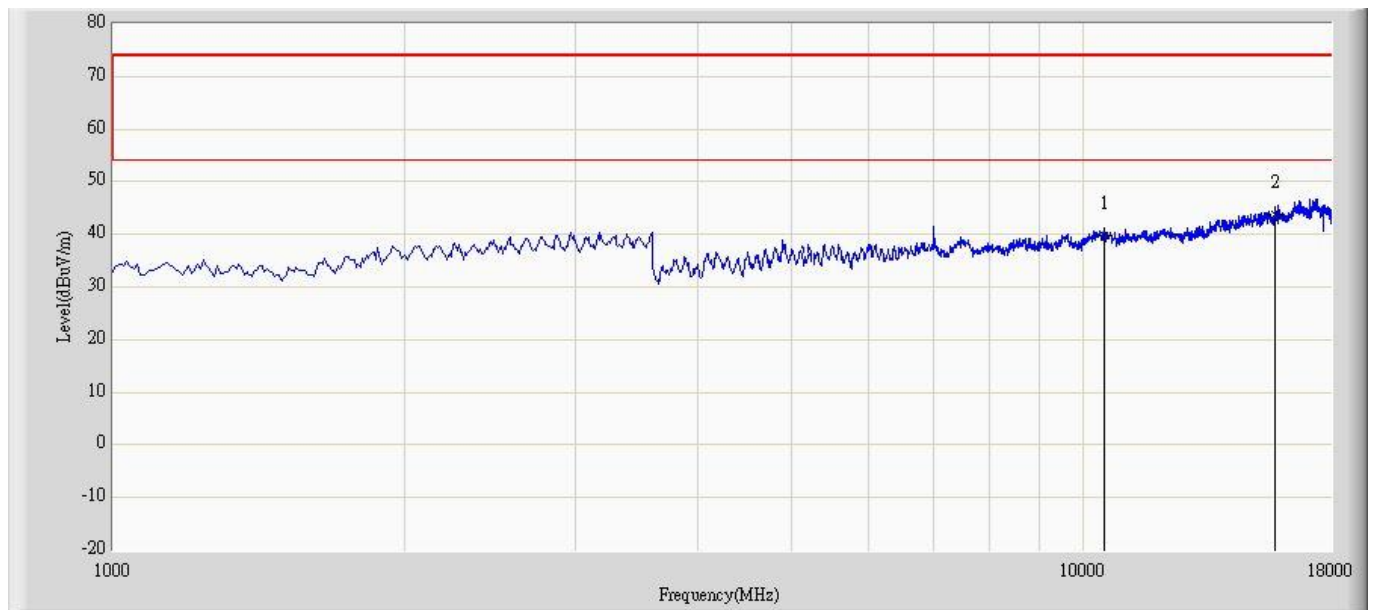

No	Flag	Mark	Frequency (MHz)	Measure Level (dBuV/m)	Reading Level (dBuV)	Over Limit (dB)	Limit (dBuV/m)	Factor	Type
1			10360.000	39.733	25.736	-34.267	74.000	13.997	PK
2		*	15540.000	43.673	20.672	-30.327	74.000	23.002	PK

Note: Measure Level (dBuV/m) = Reading Level (dBuV) + Factor (dB)

Factor (dB) = Cable Loss (dB) + Antenna Factor (dB/m) - Pre\_Amplifier Gain (dB)



Site: AC102	Time: 2016/08/10 - 16:16
Limit: FCC_Part15.209_RE(3m)	Margin: 0
Probe: BBHA 9120D(1-18GHz)	Polarity: Horizontal
EUT: IP3M-941W/941B	Power: AC 120V/60Hz
Note: Mode2: Transmit at Channel 5220MHz by 802.11n20	

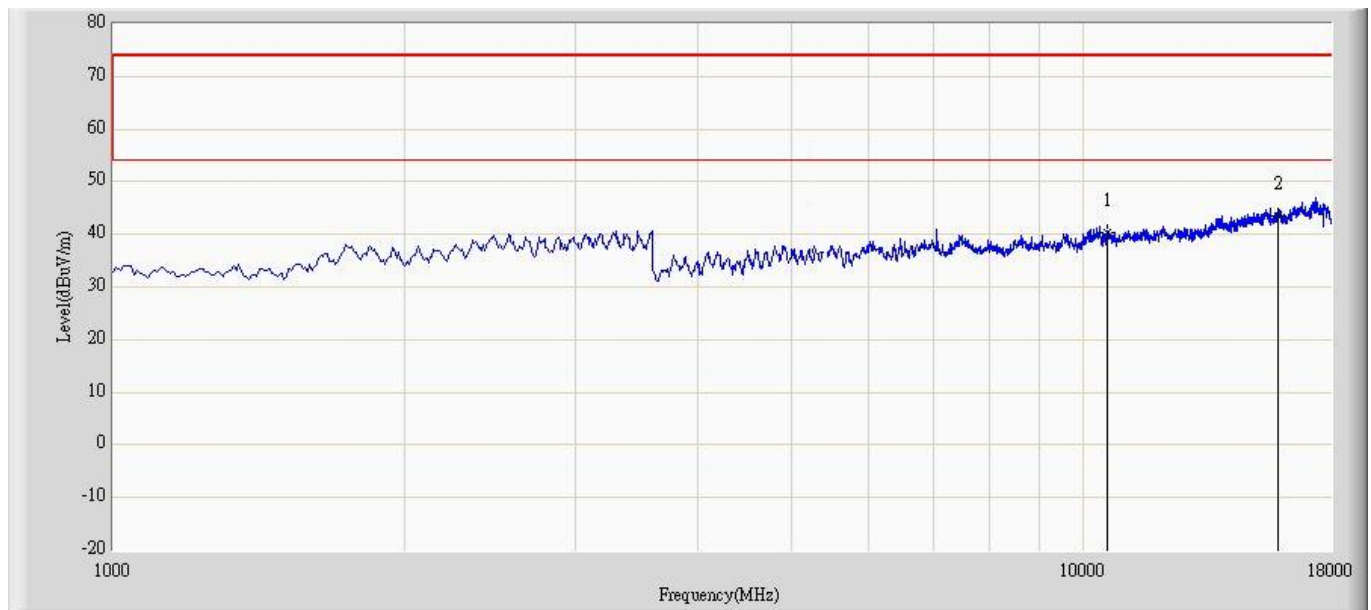

No	Flag	Mark	Frequency (MHz)	Measure Level (dBuV/m)	Reading Level (dBuV)	Over Limit (dB)	Limit (dBuV/m)	Factor	Type
1			10440.000	40.488	26.419	-33.512	74.000	14.069	PK
2		*	15660.000	43.558	20.444	-30.442	74.000	23.114	PK

Note: Measure Level (dBuV/m) = Reading Level (dBuV) + Factor (dB)

Factor (dB) = Cable Loss (dB) + Antenna Factor (dB/m) - Pre\_Amplifier Gain (dB)



Site: AC102	Time: 2016/08/10 - 16:17
Limit: FCC_Part15.209_RE(3m)	Margin: 0
Probe: BBHA 9120D(1-18GHz)	Polarity: Vertical
EUT: IP3M-941W/941B	Power: AC 120V/60Hz
Note: Mode2: Transmit at Channel 5220MHz by 802.11n20	

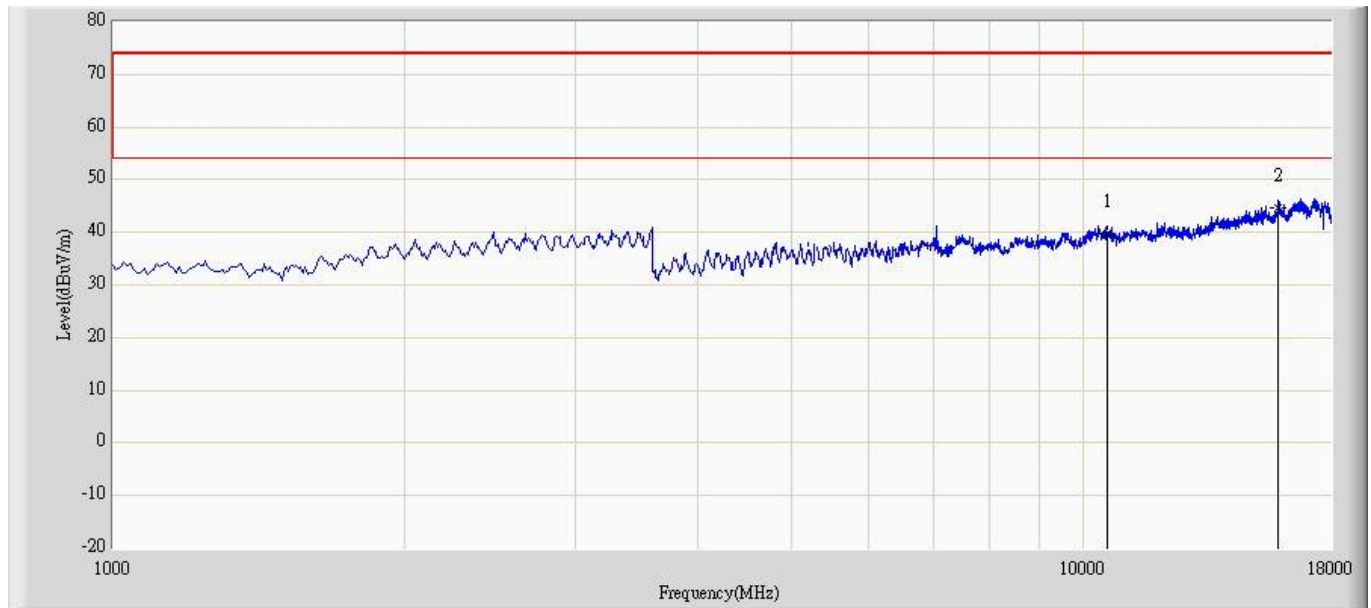

No	Flag	Mark	Frequency (MHz)	Measure Level (dBuV/m)	Reading Level (dBuV)	Over Limit (dB)	Limit (dBuV/m)	Factor	Type
1			10440.000	39.886	25.817	-34.114	74.000	14.069	PK
2		*	15660.000	44.534	21.239	-29.466	74.000	23.294	PK

Note: Measure Level (dBuV/m) = Reading Level (dBuV) + Factor (dB)

Factor (dB) = Cable Loss (dB) + Antenna Factor (dB/m) - Pre\_Amplifier Gain (dB)



Site: AC102	Time: 2016/08/10 - 16:18
Limit: FCC_Part15.209_RE(3m)	Margin: 0
Probe: BBHA 9120D(1-18GHz)	Polarity: Horizontal
EUT: IP3M-941W/941B	Power: AC 120V/60Hz
Note: Mode2: Transmit at Channel 5240MHz by 802.11n20	

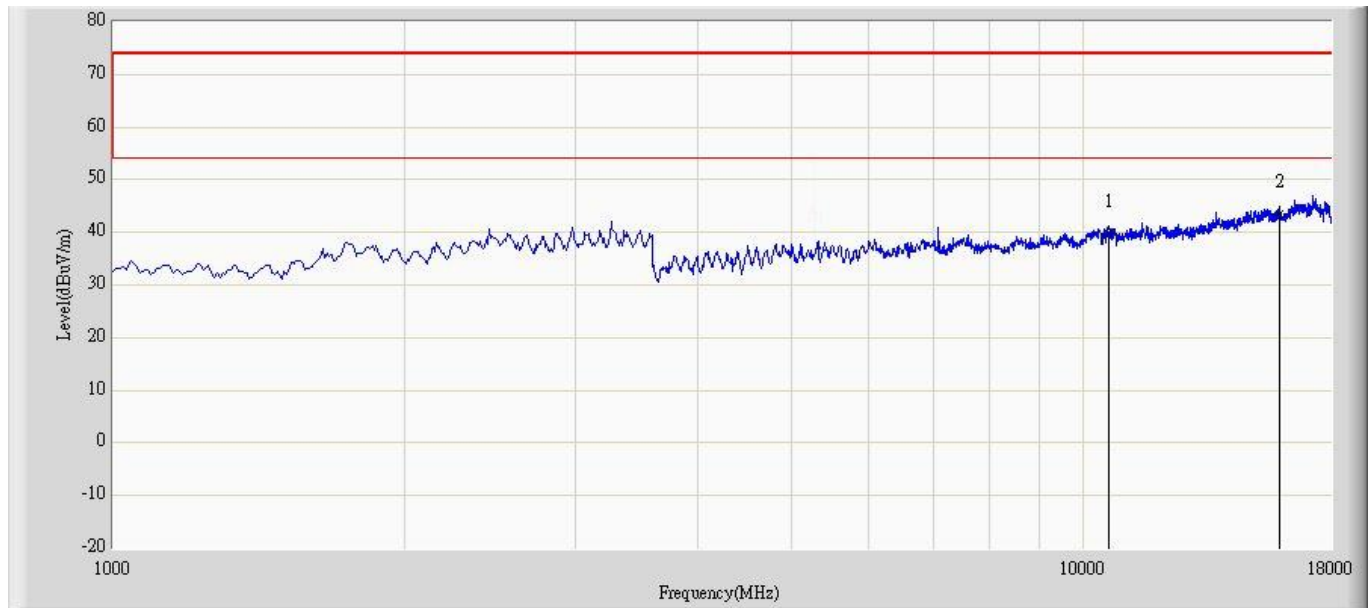

No	Flag	Mark	Frequency (MHz)	Measure Level (dBuV/m)	Reading Level (dBuV)	Over Limit (dB)	Limit (dBuV/m)	Factor	Type
1			10480.000	39.686	25.586	-34.314	74.000	14.099	PK
2		*	15720.000	43.532	20.498	-30.468	74.000	23.034	PK

Note: Measure Level (dBuV/m) = Reading Level (dBuV) + Factor (dB)

Factor (dB) = Cable Loss (dB) + Antenna Factor (dB/m) - Pre\_Amplifier Gain (dB)



Site: AC102	Time: 2016/08/10 - 16:19
Limit: FCC_Part15.209_RE(3m)	Margin: 0
Probe: BBHA 9120D(1-18GHz)	Polarity: Vertical
EUT: IP3M-941W/941B	Power: AC 120V/60Hz
Note: Mode2: Transmit at Channel 5240MHz by 802.11n20	

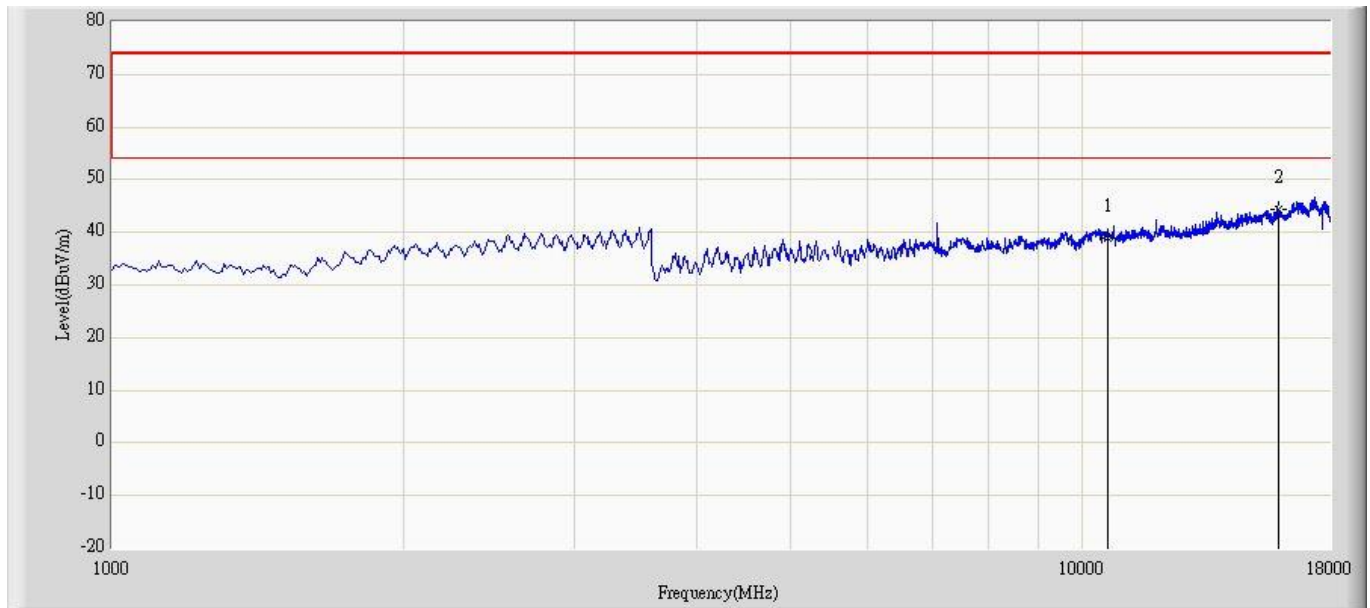

No	Flag	Mark	Frequency (MHz)	Measure Level (dBuV/m)	Reading Level (dBuV)	Over Limit (dB)	Limit (dBuV/m)	Factor	Type
1			10480.000	39.036	24.936	-34.964	74.000	14.099	PK
2		*	15720.000	44.277	20.991	-29.723	74.000	23.286	PK

Note: Measure Level (dBuV/m) = Reading Level (dBuV) + Factor (dB)

Factor (dB) = Cable Loss (dB) + Antenna Factor (dB/m) - Pre\_Amplifier Gain (dB)





Site: AC102	Time: 2016/08/10 - 16:20
Limit: FCC_Part15.209_RE(3m)	Margin: 0
Probe: BBHA 9120D(1-18GHz)	Polarity: Horizontal
EUT: IP3M-941W/941B	Power: AC 120V/60Hz
Note: Mode2: Transmit at Channel 5745MHz by 802.11n20	

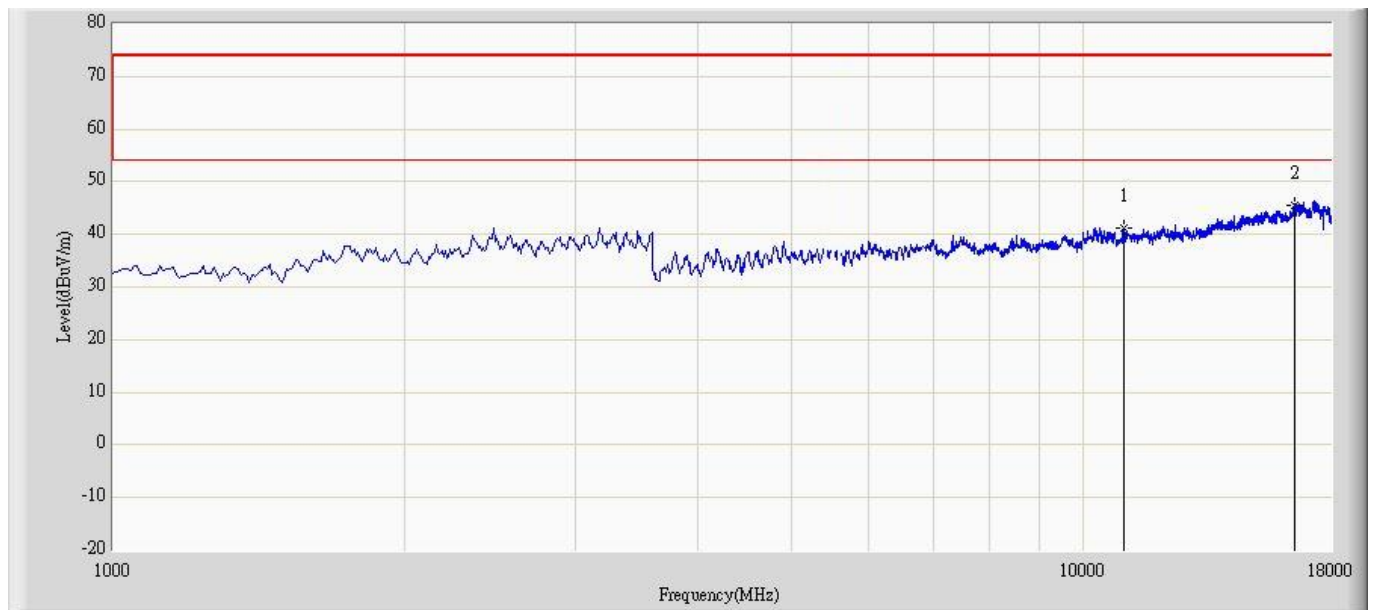

No	Flag	Mark	Frequency (MHz)	Measure Level (dBuV/m)	Reading Level (dBuV)	Over Limit (dB)	Limit (dBuV/m)	Factor	Type
1			11490.000	41.142	26.217	-32.858	74.000	14.926	PK
2		*	17235.000	45.513	23.278	-28.487	74.000	22.236	PK

Note: Measure Level (dBuV/m) = Reading Level (dBuV) + Factor (dB)

Factor (dB) = Cable Loss (dB) + Antenna Factor (dB/m) - Pre\_Amplifier Gain (dB)



Site: AC102	Time: 2016/08/10 - 16:21
Limit: FCC_Part15.209_RE(3m)	Margin: 0
Probe: BBHA 9120D(1-18GHz)	Polarity: Vertical
EUT: IP3M-941W/941B	Power: AC 120V/60Hz
Note: Mode2: Transmit at Channel 5745MHz by 802.11n20	

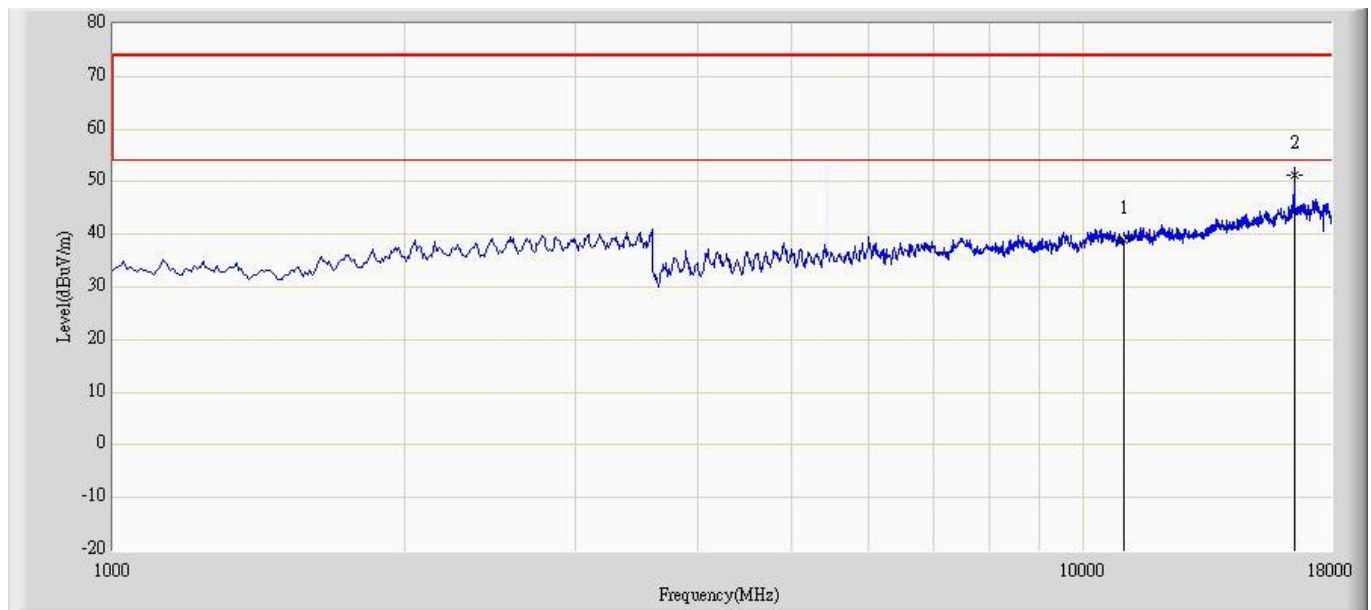

No	Flag	Mark	Frequency (MHz)	Measure Level (dBuV/m)	Reading Level (dBuV)	Over Limit (dB)	Limit (dBuV/m)	Factor	Type
1			11490.000	38.768	23.844	-35.232	74.000	14.924	PK
2		*	17235.000	51.185	28.852	-22.815	74.000	22.333	PK

Note: Measure Level (dBuV/m) = Reading Level (dBuV) + Factor (dB)

Factor (dB) = Cable Loss (dB) + Antenna Factor (dB/m) - Pre\_Amplifier Gain (dB)



Site: AC102	Time: 2016/08/10 - 16:22
Limit: FCC_Part15.209_RE(3m)	Margin: 0
Probe: BBHA 9120D(1-18GHz)	Polarity: Horizontal
EUT: IP3M-941W/941B	Power: AC 120V/60Hz
Note: Mode2: Transmit at Channel 5785MHz by 802.11n20	

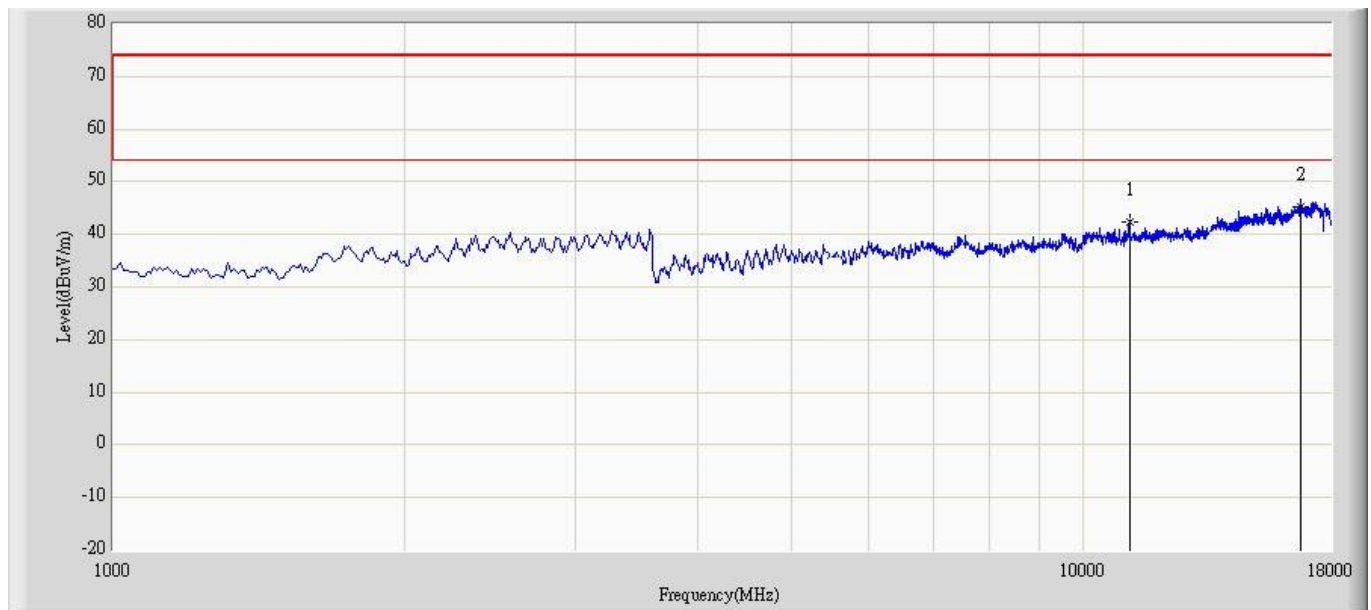

No	Flag	Mark	Frequency (MHz)	Measure Level (dBuV/m)	Reading Level (dBuV)	Over Limit (dB)	Limit (dBuV/m)	Factor	Type
1			11570.000	42.359	26.915	-31.641	74.000	15.443	PK
2		*	17355.000	45.326	22.498	-28.674	74.000	22.828	PK

Note: Measure Level (dBuV/m) = Reading Level (dBuV) + Factor (dB)

Factor (dB) = Cable Loss (dB) + Antenna Factor (dB/m) - Pre\_Amplifier Gain (dB)



Site: AC102	Time: 2016/08/10 - 16:23
Limit: FCC_Part15.209_RE(3m)	Margin: 0
Probe: BBHA 9120D(1-18GHz)	Polarity: Vertical
EUT: IP3M-941W/941B	Power: AC 120V/60Hz
Note: Mode2: Transmit at Channel 5785MHz by 802.11n20	

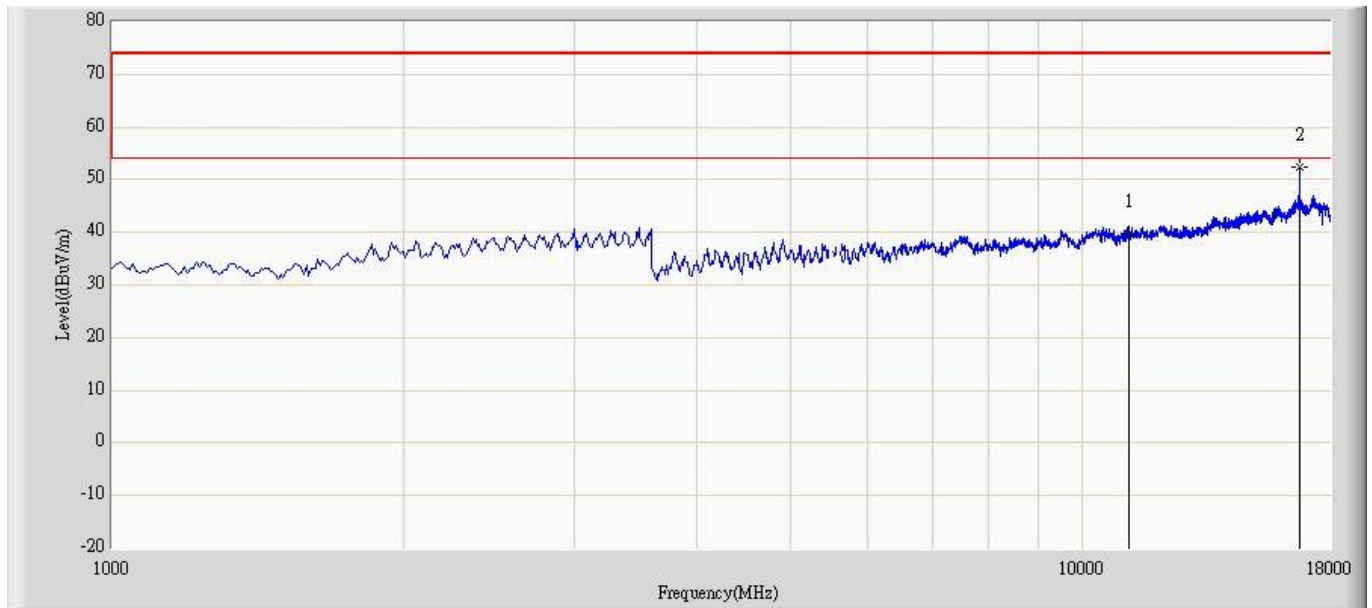

No	Flag	Mark	Frequency (MHz)	Measure Level (dBuV/m)	Reading Level (dBuV)	Over Limit (dB)	Limit (dBuV/m)	Factor	Type
1			11570.000	39.762	24.382	-34.238	74.000	15.379	PK
2		*	17355.000	52.405	29.487	-21.595	74.000	22.918	PK

Note: Measure Level (dBuV/m) = Reading Level (dBuV) + Factor (dB)

Factor (dB) = Cable Loss (dB) + Antenna Factor (dB/m) - Pre\_Amplifier Gain (dB)



Site: AC102	Time: 2016/08/10 - 16:25
Limit: FCC_Part15.209_RE(3m)	Margin: 0
Probe: BBHA 9120D(1-18GHz)	Polarity: Horizontal
EUT: IP3M-941W/941B	Power: AC 120V/60Hz
Note: Mode2: Transmit at Channel 5825MHz by 802.11n20	

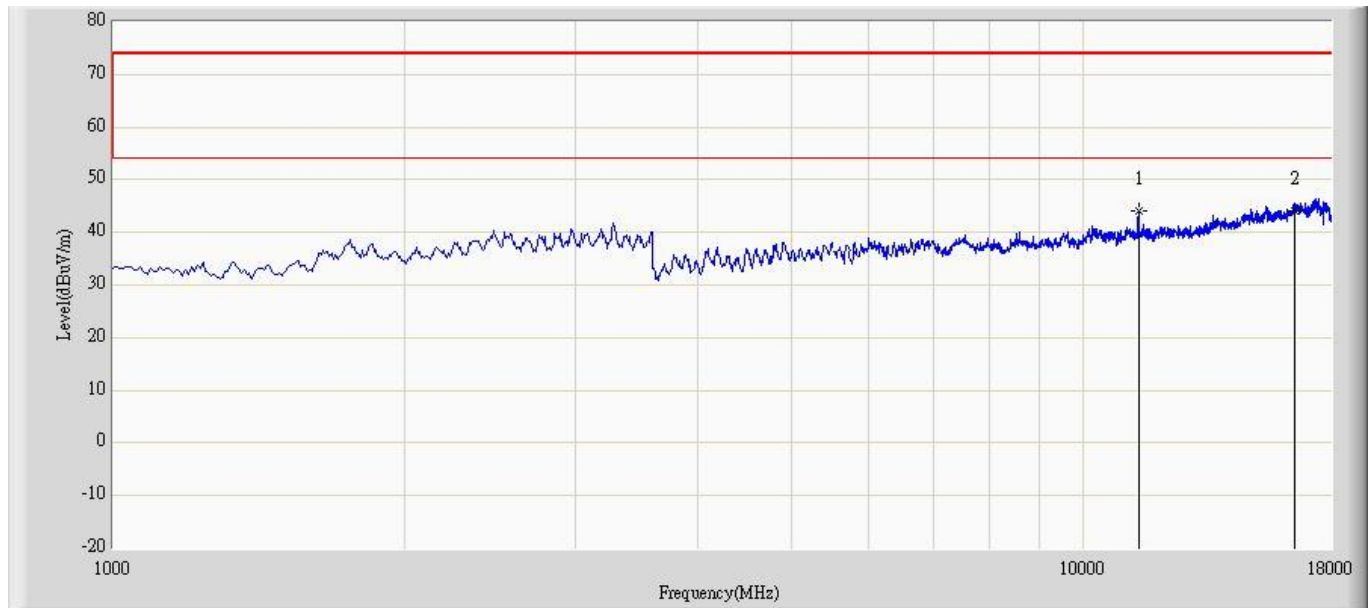

No	Flag	Mark	Frequency (MHz)	Measure Level (dBuV/m)	Reading Level (dBuV)	Over Limit (dB)	Limit (dBuV/m)	Factor	Type
1			11650.000	43.978	28.021	-30.022	74.000	15.957	PK
2		*	17475.000	44.074	21.839	-29.926	74.000	22.236	PK

Note: Measure Level (dBuV/m) = Reading Level (dBuV) + Factor (dB)

Factor (dB) = Cable Loss (dB) + Antenna Factor (dB/m) - Pre\_Amplifier Gain (dB)



Site: AC102	Time: 2016/08/10 - 16:26
Limit: FCC_Part15.209_RE(3m)	Margin: 0
Probe: BBHA 9120D(1-18GHz)	Polarity: Vertical
EUT: IP3M-941W/941B	Power: AC 120V/60Hz
Note: Mode2: Transmit at Channel 5825MHz by 802.11n20	

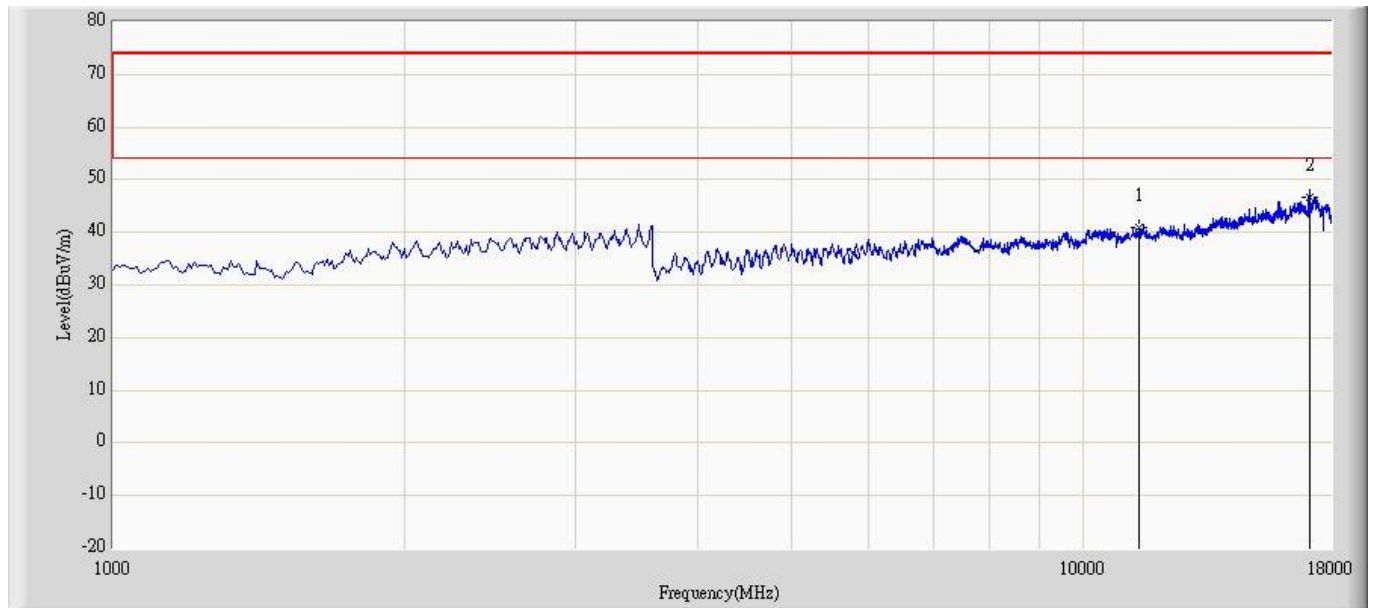

No	Flag	Mark	Frequency (MHz)	Measure Level (dBuV/m)	Reading Level (dBuV)	Over Limit (dB)	Limit (dBuV/m)	Factor	Type
1			11650.000	40.931	25.091	-33.069	74.000	15.839	PK
2		*	17475.000	46.794	23.118	-27.206	74.000	23.676	PK

Note: Measure Level (dBuV/m) = Reading Level (dBuV) + Factor (dB)

Factor (dB) = Cable Loss (dB) + Antenna Factor (dB/m) - Pre\_Amplifier Gain (dB)



Site: AC102	Time: 2016/08/10 - 16:27
Limit: FCC_Part15.209_RE(3m)	Margin: 0
Probe: BBHA 9120D(1-18GHz)	Polarity: Horizontal
EUT: IP3M-941W/941B	Power: AC 120V/60Hz
Note: Mode3: Transmit at Channel 5180MHz by 802.11ac20	

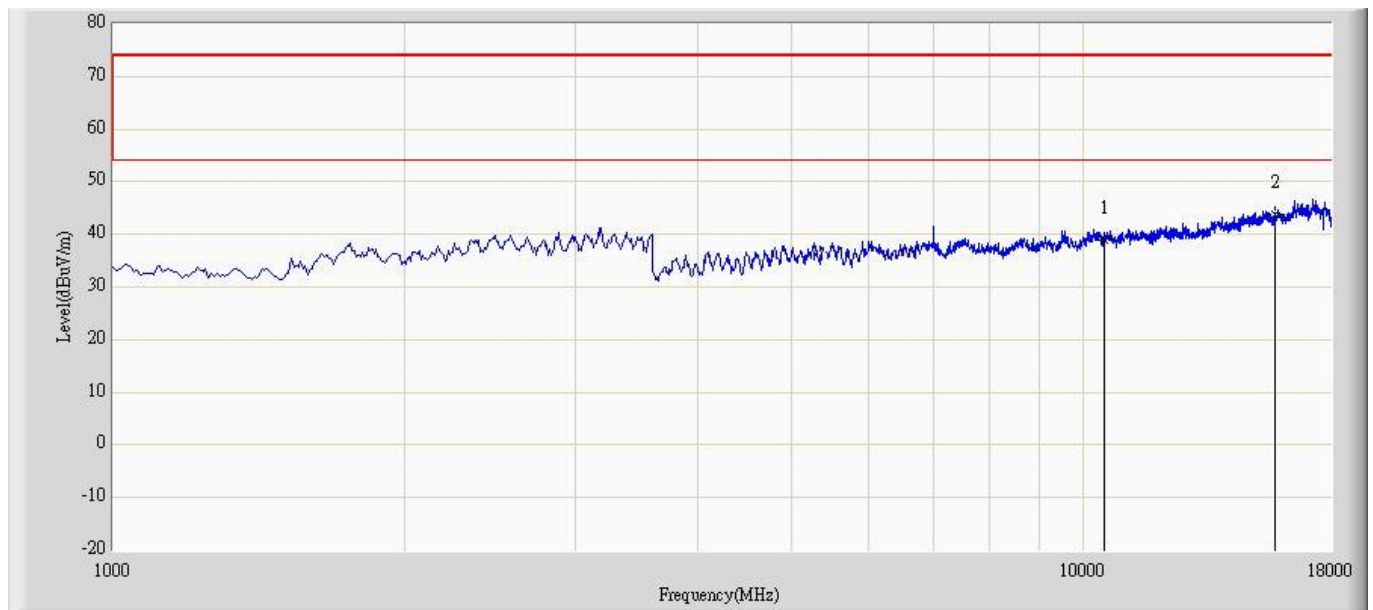

No	Flag	Mark	Frequency (MHz)	Measure Level (dBuV/m)	Reading Level (dBuV)	Over Limit (dB)	Limit (dBuV/m)	Factor	Type
1			10360.000	39.049	25.052	-34.951	74.000	13.997	PK
2		*	15540.000	43.771	20.805	-30.229	74.000	22.966	PK

Note: Measure Level (dBuV/m) = Reading Level (dBuV) + Factor (dB)

Factor (dB) = Cable Loss (dB) + Antenna Factor (dB/m) - Pre\_Amplifier Gain (dB)



Site: AC102	Time: 2016/08/10 - 16:28
Limit: FCC_Part15.209_RE(3m)	Margin: 0
Probe: BBHA 9120D(1-18GHz)	Polarity: Vertical
EUT: IP3M-941W/941B	Power: AC 120V/60Hz
Note: Mode3: Transmit at Channel 5180MHz by 802.11ac20	

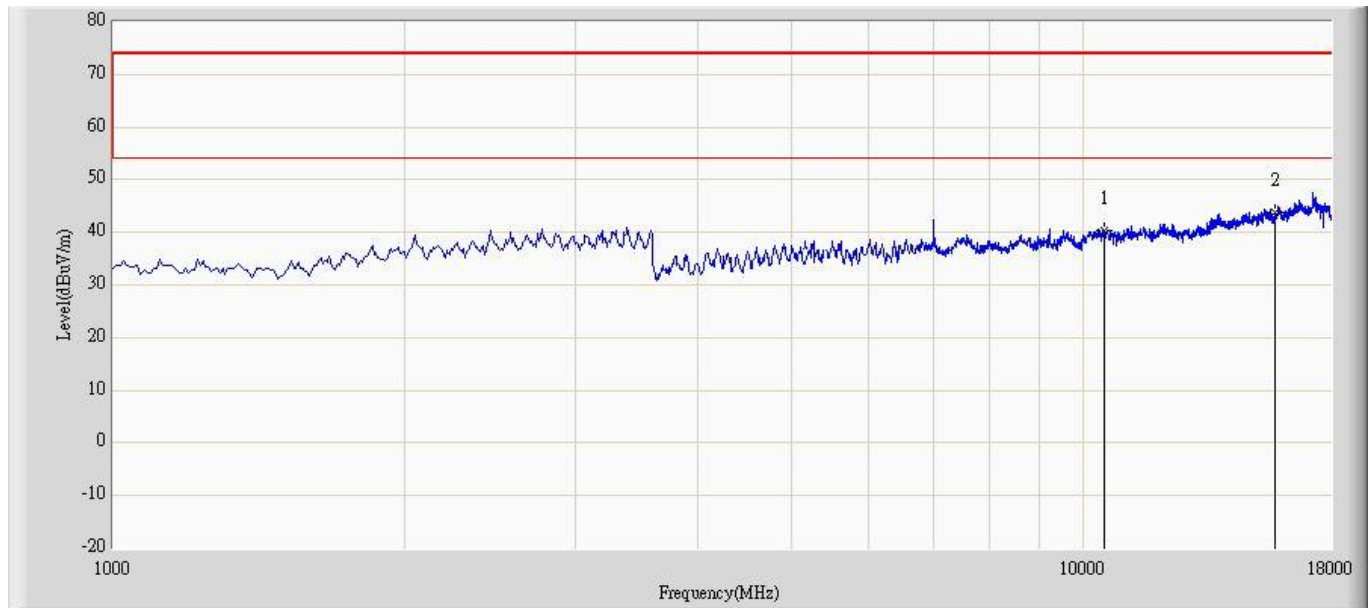

No	Flag	Mark	Frequency (MHz)	Measure Level (dBuV/m)	Reading Level (dBuV)	Over Limit (dB)	Limit (dBuV/m)	Factor	Type
1			10360.000	40.242	26.245	-33.758	74.000	13.997	PK
2		*	15540.000	43.742	20.741	-30.258	74.000	23.002	PK

Note: Measure Level (dBuV/m) = Reading Level (dBuV) + Factor (dB)

Factor (dB) = Cable Loss (dB) + Antenna Factor (dB/m) - Pre\_Amplifier Gain (dB)





Site: AC102	Time: 2016/08/10 - 16:29
Limit: FCC_Part15.209_RE(3m)	Margin: 0
Probe: BBHA 9120D(1-18GHz)	Polarity: Horizontal
EUT: IP3M-941W/941B	Power: AC 120V/60Hz
Note: Mode3: Transmit at Channel 5220MHz by 802.11ac20	

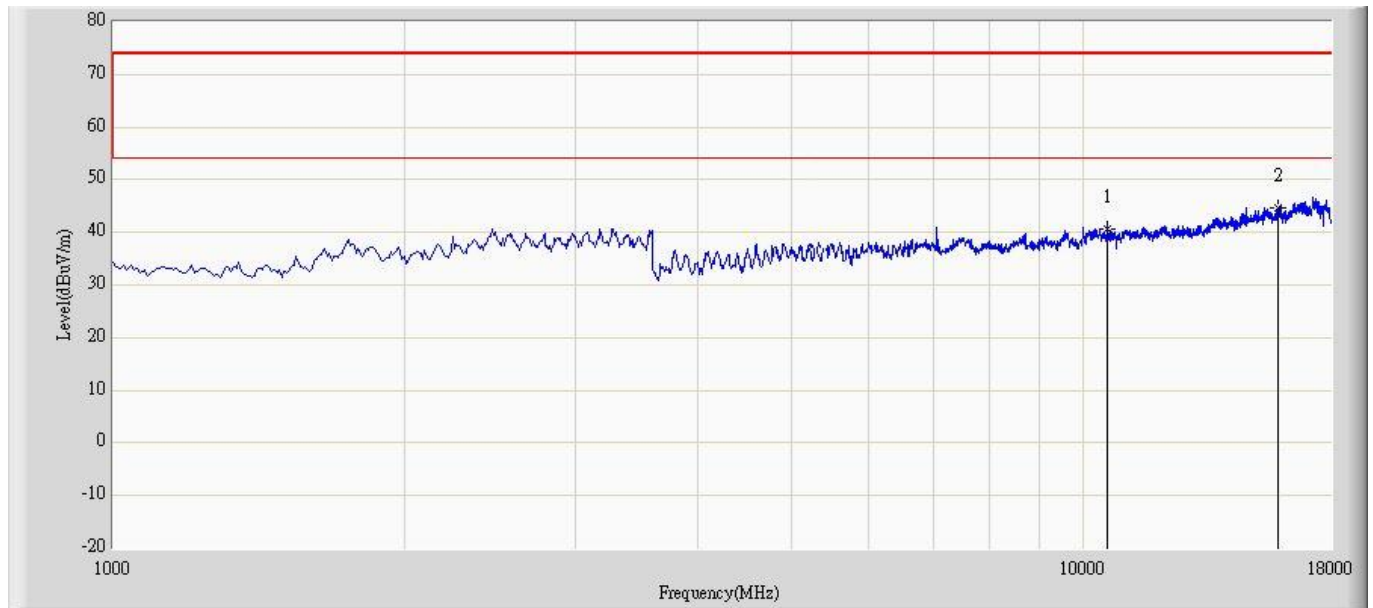

No	Flag	Mark	Frequency (MHz)	Measure Level (dBuV/m)	Reading Level (dBuV)	Over Limit (dB)	Limit (dBuV/m)	Factor	Type
1			10440.000	40.757	26.688	-33.243	74.000	14.069	PK
2		*	15660.000	44.702	21.588	-29.298	74.000	23.114	PK

Note: Measure Level (dBuV/m) = Reading Level (dBuV) + Factor (dB)

Factor (dB) = Cable Loss (dB) + Antenna Factor (dB/m) - Pre\_Amplifier Gain (dB)



Site: AC102	Time: 2016/08/10 - 16:30
Limit: FCC_Part15.209_RE(3m)	Margin: 0
Probe: BBHA 9120D(1-18GHz)	Polarity: Vertical
EUT: IP3M-941W/941B	Power: AC 120V/60Hz
Note: Mode3: Transmit at Channel 5220MHz by 802.11ac20	

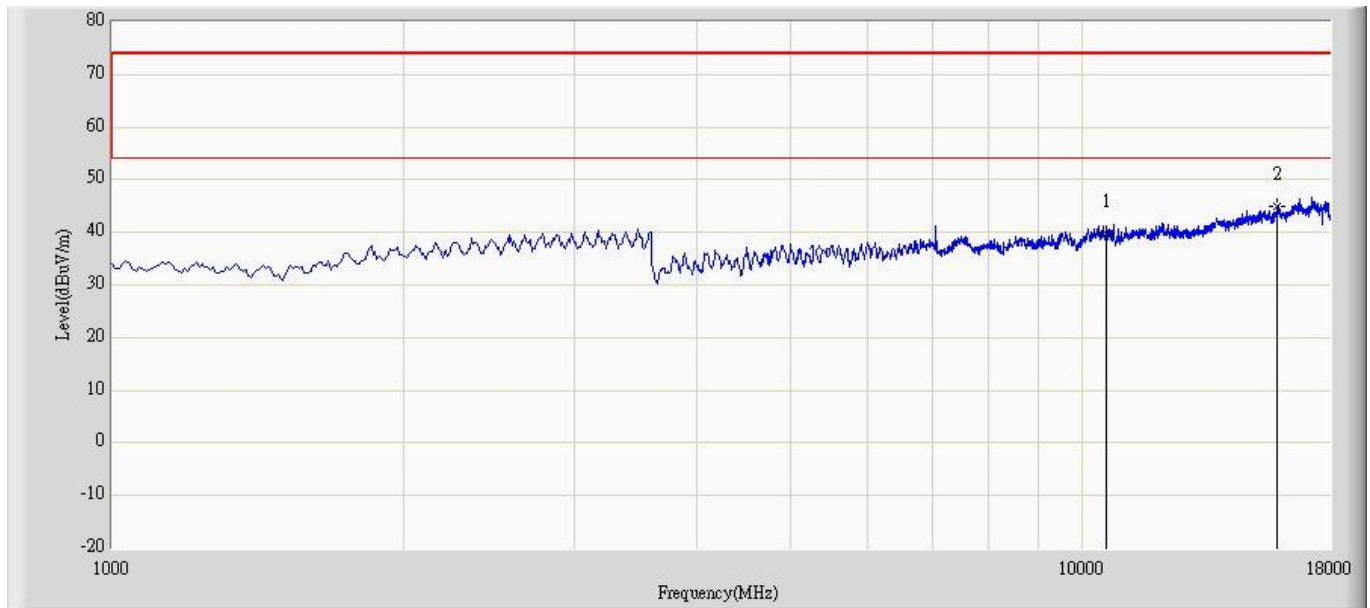

No	Flag	Mark	Frequency (MHz)	Measure Level (dBuV/m)	Reading Level (dBuV)	Over Limit (dB)	Limit (dBuV/m)	Factor	Type
1			10440.000	39.762	25.693	-34.238	74.000	14.069	PK
2		*	15660.000	44.956	21.661	-29.044	74.000	23.294	PK

Note: Measure Level (dBuV/m) = Reading Level (dBuV) + Factor (dB)

Factor (dB) = Cable Loss (dB) + Antenna Factor (dB/m) - Pre\_Amplifier Gain (dB)



Site: AC102	Time: 2016/08/10 - 16:54
Limit: FCC_Part15.209_RE(3m)	Margin: 0
Probe: BBHA 9120D(1-18GHz)	Polarity: Horizontal
EUT: IP3M-941W/941B	Power: AC 120V/60Hz
Note: Mode3: Transmit at Channel 5240MHz by 802.11ac20	

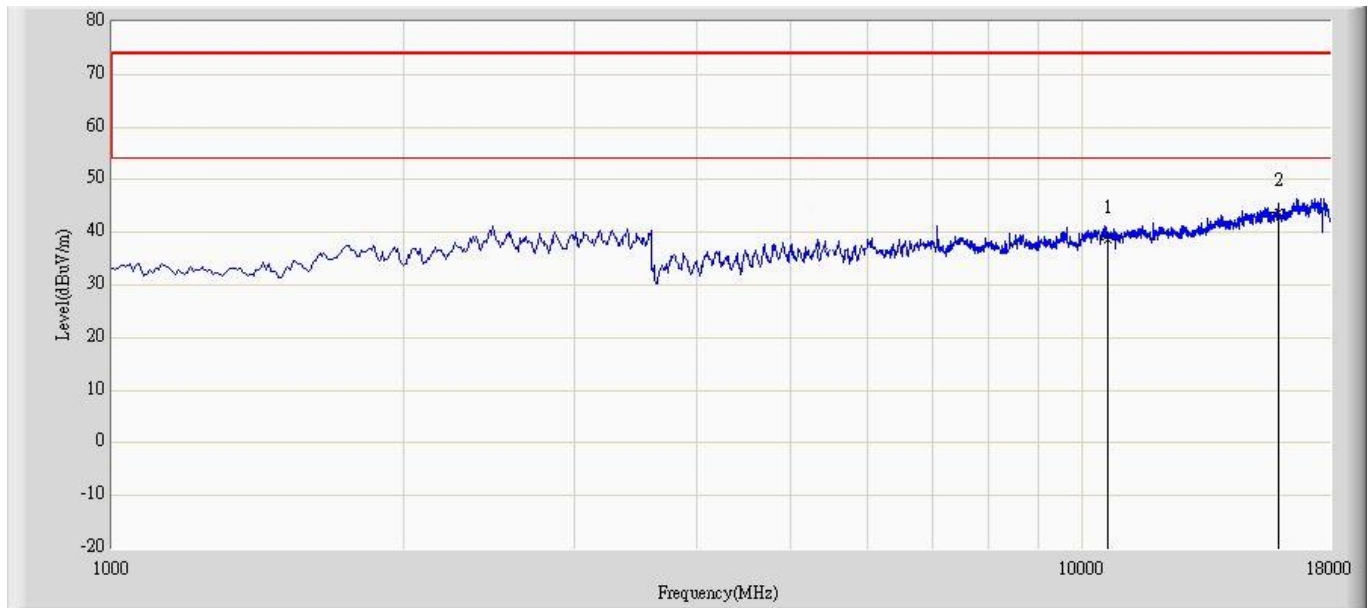

No	Flag	Mark	Frequency (MHz)	Measure Level (dBuV/m)	Reading Level (dBuV)	Over Limit (dB)	Limit (dBuV/m)	Factor	Type
1			10480.000	38.590	24.490	-35.410	74.000	14.099	PK
2		*	15720.000	43.789	20.755	-30.211	74.000	23.034	PK

Note: Measure Level (dBuV/m) = Reading Level (dBuV) + Factor (dB)

Factor (dB) = Cable Loss (dB) + Antenna Factor (dB/m) - Pre\_Amplifier Gain (dB)



Site: AC102	Time: 2016/08/10 - 16:55
Limit: FCC_Part15.209_RE(3m)	Margin: 0
Probe: BBHA 9120D(1-18GHz)	Polarity: Vertical
EUT: IP3M-941W/941B	Power: AC 120V/60Hz
Note: Mode3: Transmit at Channel 5240MHz by 802.11ac20	

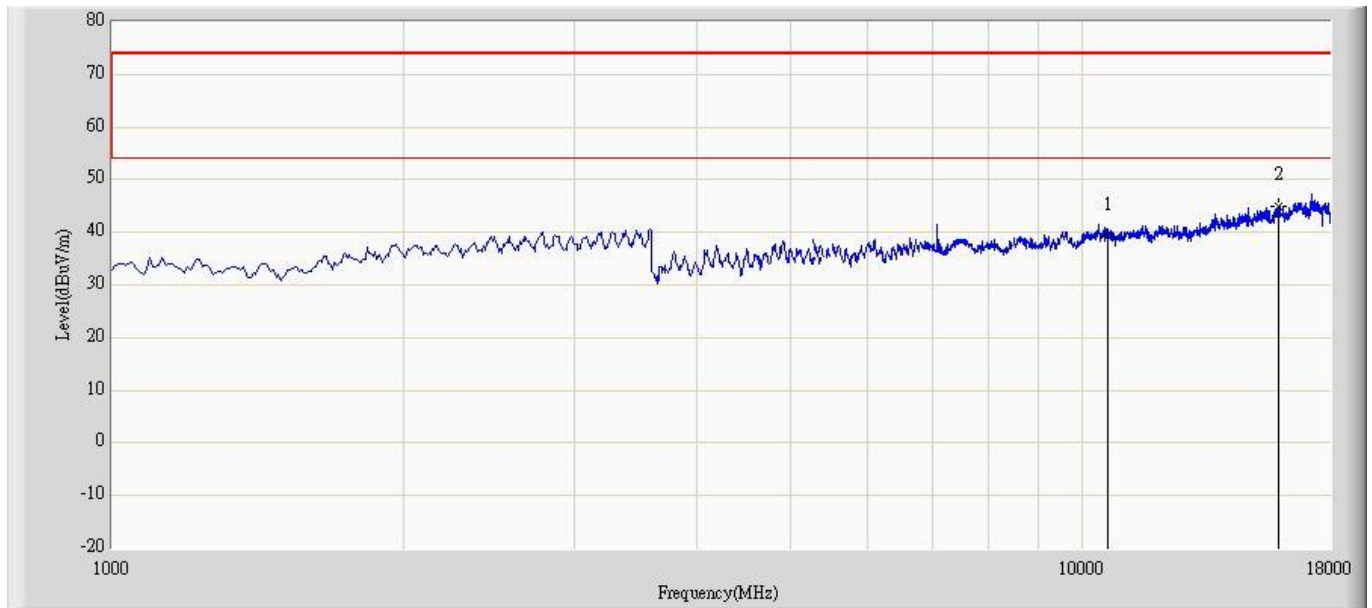

No	Flag	Mark	Frequency (MHz)	Measure Level (dBuV/m)	Reading Level (dBuV)	Over Limit (dB)	Limit (dBuV/m)	Factor	Type
1			10480.000	39.256	25.156	-34.744	74.000	14.099	PK
2		*	15720.000	45.018	21.732	-28.982	74.000	23.286	PK

Note: Measure Level (dBuV/m) = Reading Level (dBuV) + Factor (dB)

Factor (dB) = Cable Loss (dB) + Antenna Factor (dB/m) - Pre\_Amplifier Gain (dB)



Site: AC102	Time: 2016/08/10 - 16:56
Limit: FCC_Part15.209_RE(3m)	Margin: 0
Probe: BBHA 9120D(1-18GHz)	Polarity: Horizontal
EUT: IP3M-941W/941B	Power: AC 120V/60Hz
Note: Mode3: Transmit at Channel 5745MHz by 802.11ac20	

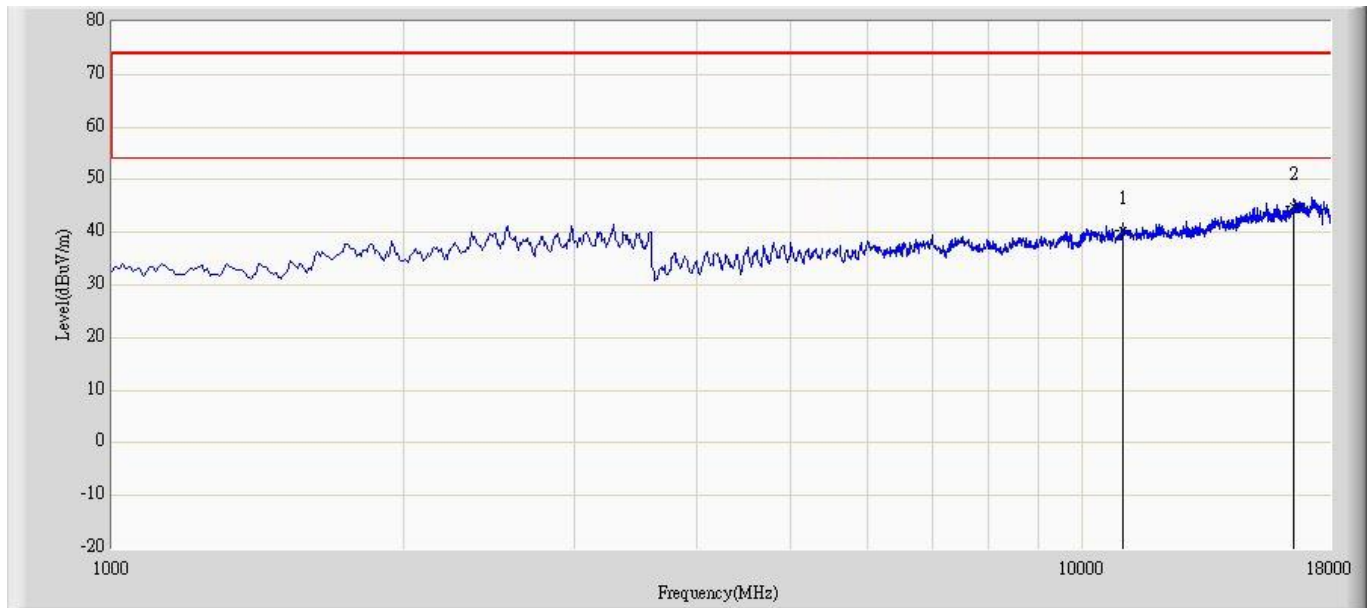

No	Flag	Mark	Frequency (MHz)	Measure Level (dBuV/m)	Reading Level (dBuV)	Over Limit (dB)	Limit (dBuV/m)	Factor	Type
1			11490.000	40.306	25.381	-33.694	74.000	14.926	PK
2		*	17235.000	44.983	22.748	-29.017	74.000	22.236	PK

Note: Measure Level (dBuV/m) = Reading Level (dBuV) + Factor (dB)

Factor (dB) = Cable Loss (dB) + Antenna Factor (dB/m) - Pre\_Amplifier Gain (dB)



Site: AC102	Time: 2016/08/10 - 16:57
Limit: FCC_Part15.209_RE(3m)	Margin: 0
Probe: BBHA 9120D(1-18GHz)	Polarity: Vertical
EUT: IP3M-941W/941B	Power: AC 120V/60Hz
Note: Mode3: Transmit at Channel 5745MHz by 802.11ac20	

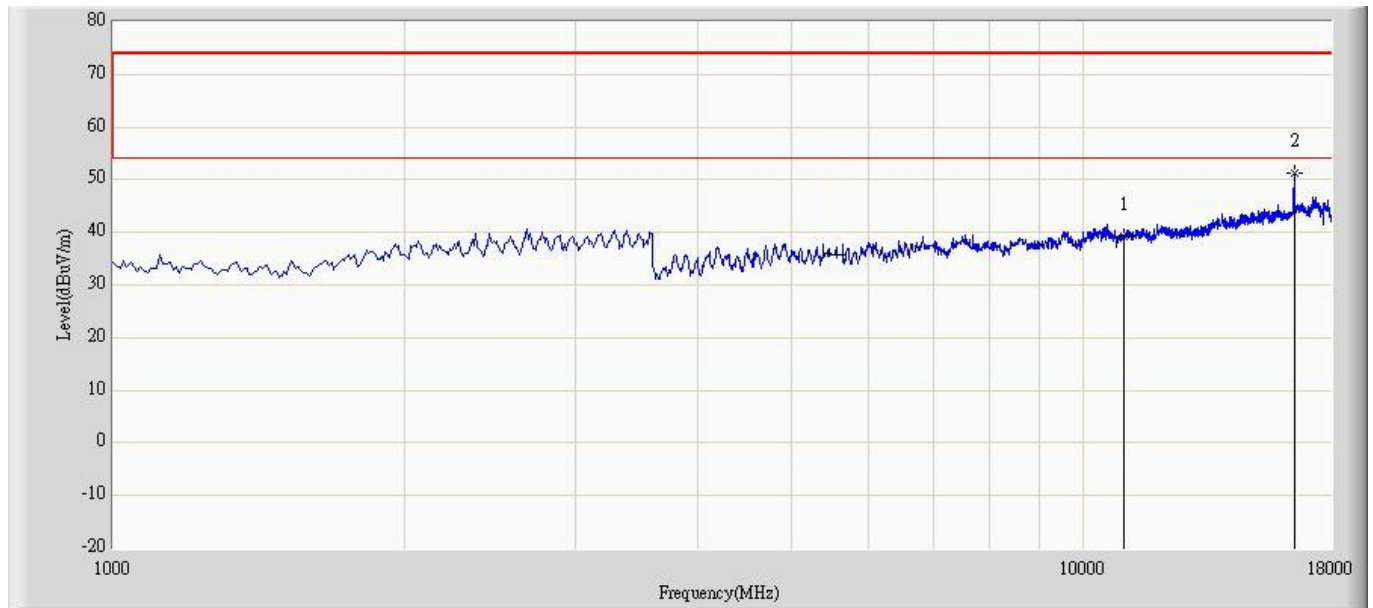

No	Flag	Mark	Frequency (MHz)	Measure Level (dBuV/m)	Reading Level (dBuV)	Over Limit (dB)	Limit (dBuV/m)	Factor	Type
1			11490.000	39.263	24.339	-34.737	74.000	14.924	PK
2		*	17235.000	51.346	29.014	-22.654	74.000	22.332	PK

Note: Measure Level (dBuV/m) = Reading Level (dBuV) + Factor (dB)

Factor (dB) = Cable Loss (dB) + Antenna Factor (dB/m) - Pre\_Amplifier Gain (dB)



Site: AC102	Time: 2016/08/10 - 17:01
Limit: FCC_Part15.209_RE(3m)	Margin: 0
Probe: BBHA 9120D(1-18GHz)	Polarity: Horizontal
EUT: IP3M-941W/941B	Power: AC 120V/60Hz
Note: Mode3: Transmit at Channel 5785MHz by 802.11ac20	

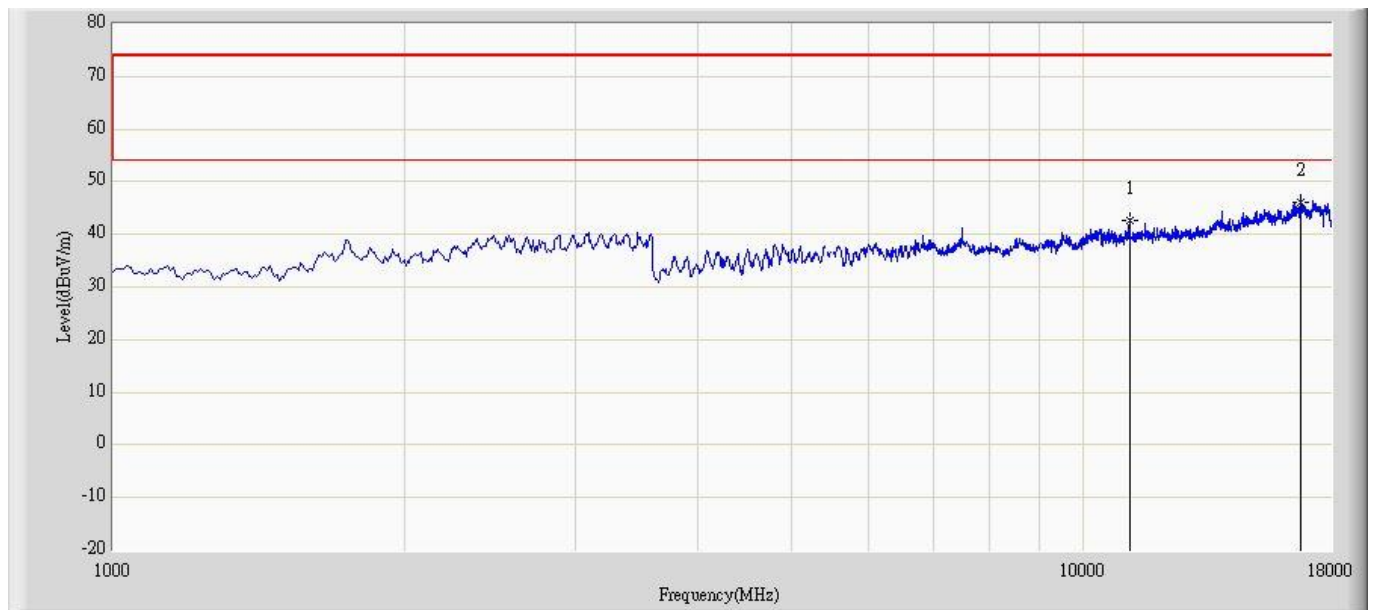

No	Flag	Mark	Frequency (MHz)	Measure Level (dBuV/m)	Reading Level (dBuV)	Over Limit (dB)	Limit (dBuV/m)	Factor	Type
1			11570.000	42.548	27.104	-31.452	74.000	15.443	PK
2		*	17355.000	46.038	23.210	-27.962	74.000	22.828	PK

Note: Measure Level (dBuV/m) = Reading Level (dBuV) + Factor (dB)

Factor (dB) = Cable Loss (dB) + Antenna Factor (dB/m) - Pre\_Amplifier Gain (dB)



Site: AC102	Time: 2016/08/10 - 17:01
Limit: FCC_Part15.209_RE(3m)	Margin: 0
Probe: BBHA 9120D(1-18GHz)	Polarity: Vertical
EUT: IP3M-941W/941B	Power: AC 120V/60Hz
Note: Mode3: Transmit at Channel 5785MHz by 802.11ac20	

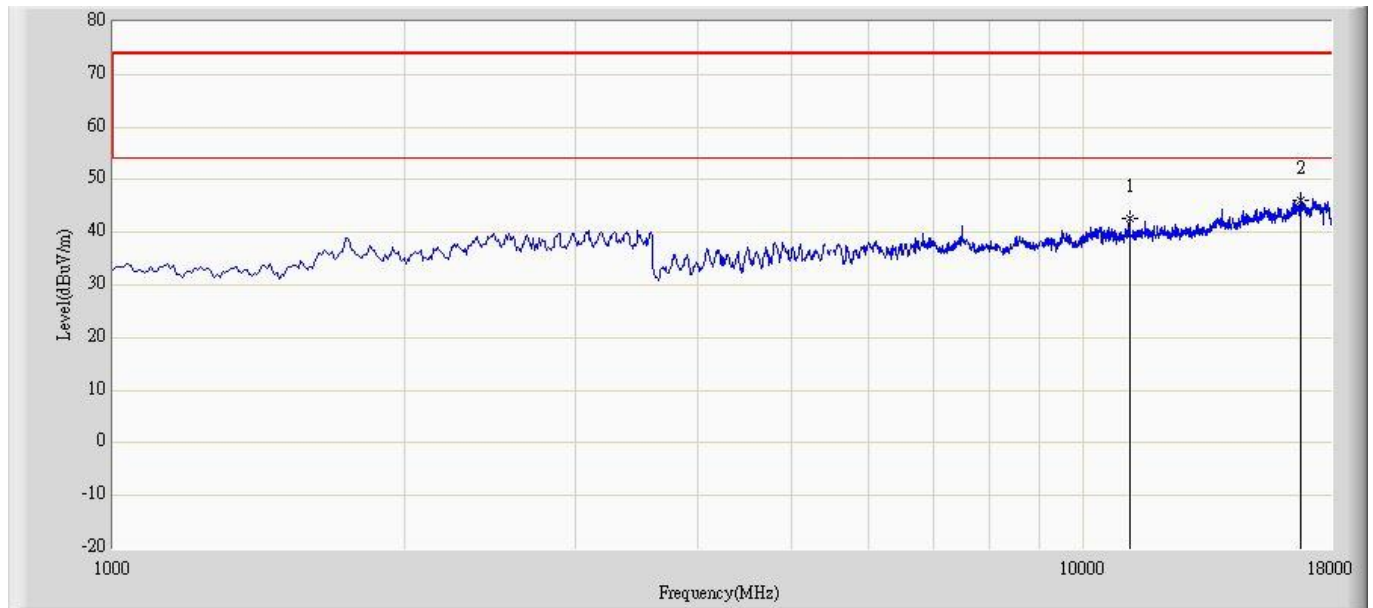

No	Flag	Mark	Frequency (MHz)	Measure Level (dBuV/m)	Reading Level (dBuV)	Over Limit (dB)	Limit (dBuV/m)	Factor	Type
1			11570.000	39.615	24.235	-34.385	74.000	15.379	PK
2		*	17355.000	48.796	25.868	-25.204	74.000	22.928	PK

Note: Measure Level (dBuV/m) = Reading Level (dBuV) + Factor (dB)

Factor (dB) = Cable Loss (dB) + Antenna Factor (dB/m) - Pre\_Amplifier Gain (dB)





Site: AC102	Time: 2016/08/10 - 17:03
Limit: FCC_Part15.209_RE(3m)	Margin: 0
Probe: BBHA 9120D(1-18GHz)	Polarity: Horizontal
EUT: IP3M-941W/941B	Power: AC 120V/60Hz
Note: Mode3: Transmit at Channel 5825MHz by 802.11ac20	

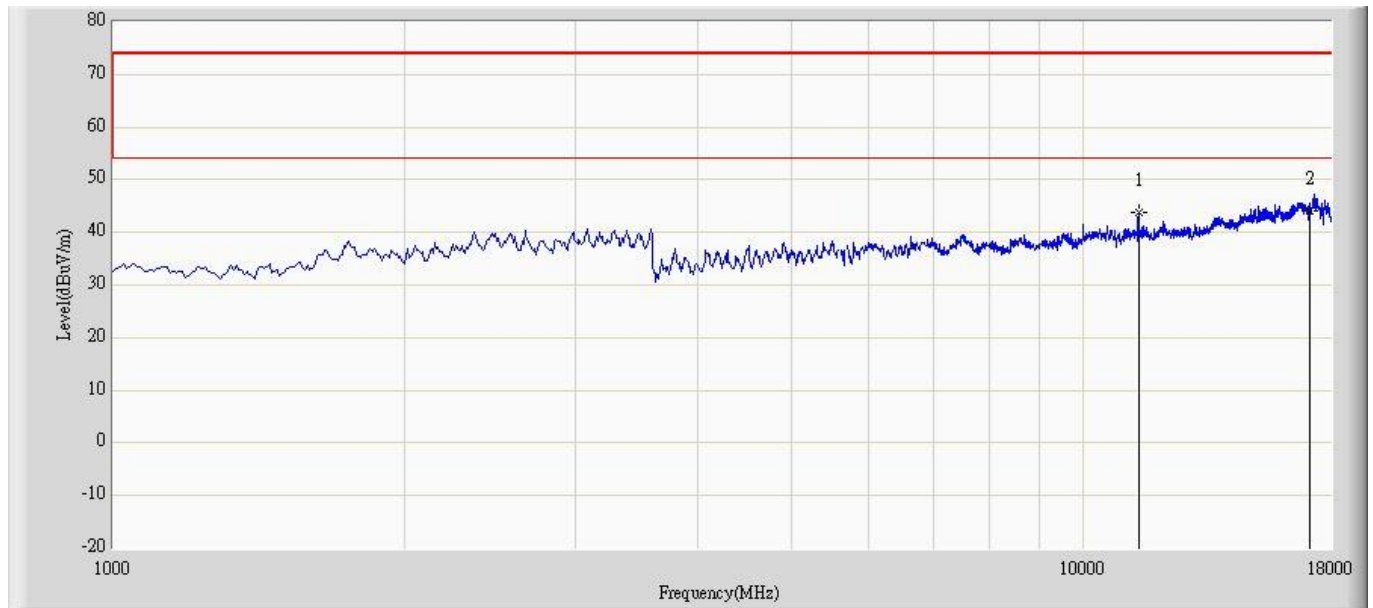

No	Flag	Mark	Frequency (MHz)	Measure Level (dBuV/m)	Reading Level (dBuV)	Over Limit (dB)	Limit (dBuV/m)	Factor	Type
1			11650.000	43.777	27.837	-30.223	74.000	15.939	PK
2		*	17475.000	44.050	20.234	-29.950	74.000	23.816	PK

Note: Measure Level (dBuV/m) = Reading Level (dBuV) + Factor (dB)

Factor (dB) = Cable Loss (dB) + Antenna Factor (dB/m) - Pre\_Amplifier Gain (dB)



Site: AC102	Time: 2016/08/10 - 17:04
Limit: FCC_Part15.209_RE(3m)	Margin: 0
Probe: BBHA 9120D(1-18GHz)	Polarity: Vertical
EUT: IP3M-941W/941B	Power: AC 120V/60Hz
Note: Mode3: Transmit at Channel 5825MHz by 802.11ac20	

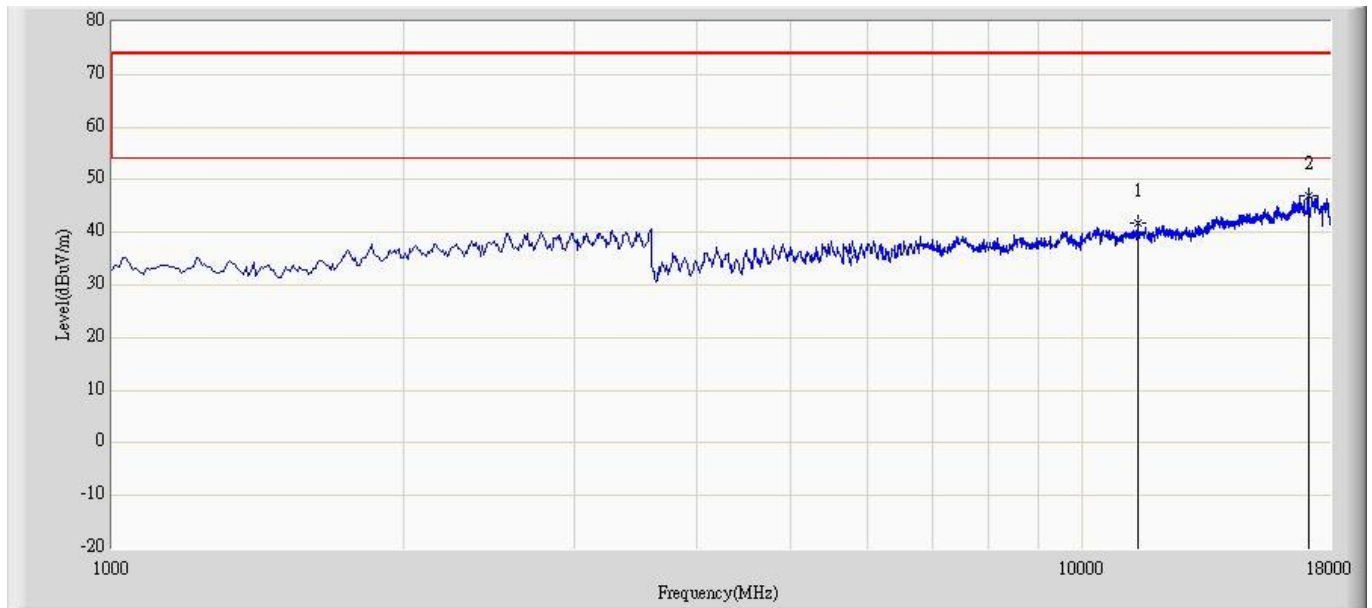

No	Flag	Mark	Frequency (MHz)	Measure Level (dBuV/m)	Reading Level (dBuV)	Over Limit (dB)	Limit (dBuV/m)	Factor	Type
1			11650.000	41.696	25.856	-32.304	74.000	15.839	PK
2		*	17475.000	46.871	23.195	-27.129	74.000	23.676	PK

Note: Measure Level (dBuV/m) = Reading Level (dBuV) + Factor (dB)

Factor (dB) = Cable Loss (dB) + Antenna Factor (dB/m) - Pre\_Amplifier Gain (dB)



Site: AC102	Time: 2016/08/10 - 17:37
Limit: FCC_Part15.209_RE(3m)	Margin: 0
Probe: BBHA 9120D(1-18GHz)	Polarity: Horizontal
EUT: IP3M-941W/941B	Power: AC 120V/60Hz
Note: Mode4: Transmit at Channel 5190MHz by 802.11n40	

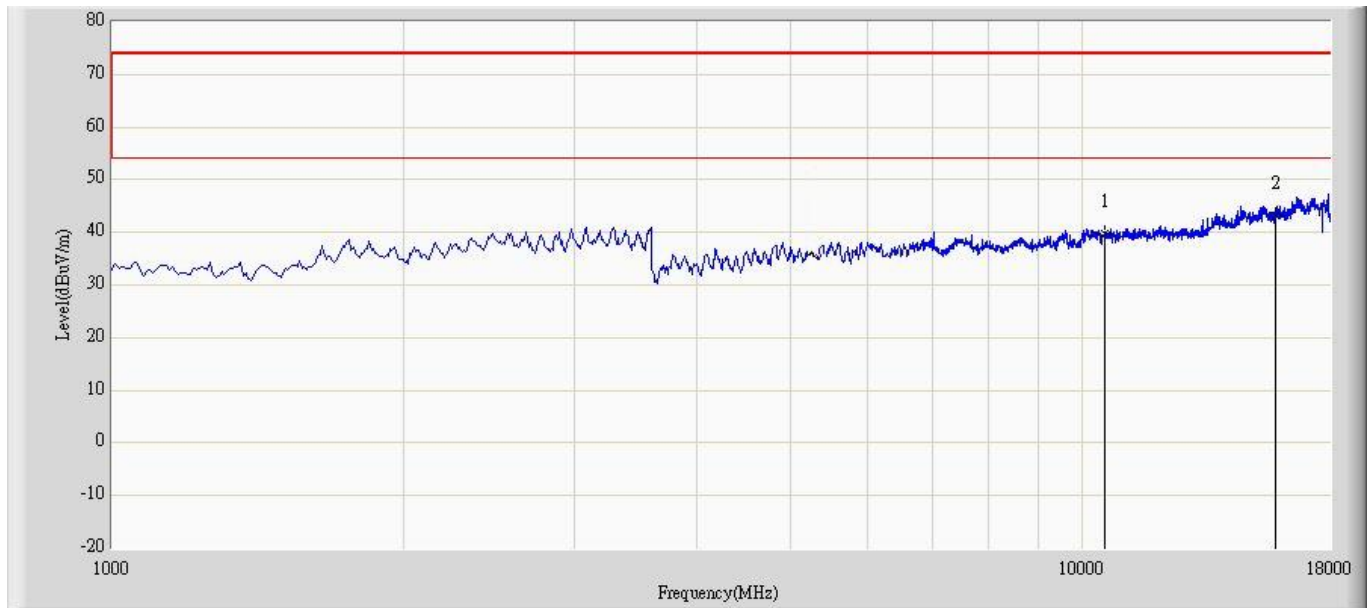

No	Flag	Mark	Frequency (MHz)	Measure Level (dBuV/m)	Reading Level (dBuV)	Over Limit (dB)	Limit (dBuV/m)	Factor	Type
1			10380.000	39.803	25.803	-34.197	74.000	13.999	PK
2		*	15570.000	43.103	20.161	-30.897	74.000	22.943	PK

Note: Measure Level (dBuV/m) = Reading Level (dBuV) + Factor (dB)

Factor (dB) = Cable Loss (dB) + Antenna Factor (dB/m) - Pre\_Amplifier Gain (dB)



Site: AC102	Time: 2016/08/10 - 17:38
Limit: FCC_Part15.209_RE(3m)	Margin: 0
Probe: BBHA 9120D(1-18GHz)	Polarity: Vertical
EUT: IP3M-941W/941B	Power: AC 120V/60Hz
Note: Mode4: Transmit at Channel 5190MHz by 802.11n40	

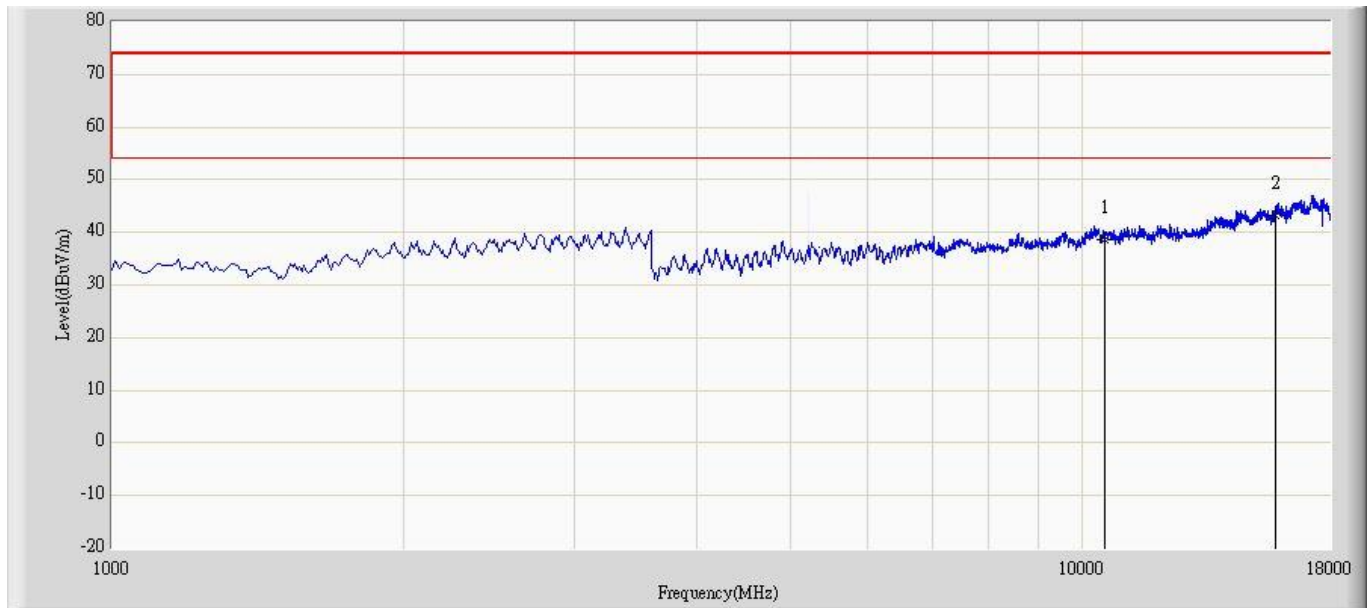

No	Flag	Mark	Frequency (MHz)	Measure Level (dBuV/m)	Reading Level (dBuV)	Over Limit (dB)	Limit (dBuV/m)	Factor	Type
1			10380.000	38.720	24.720	-35.280	74.000	13.999	PK
2		*	15570.000	43.289	20.274	-30.711	74.000	23.015	PK

Note: Measure Level (dBuV/m) = Reading Level (dBuV) + Factor (dB)

Factor (dB) = Cable Loss (dB) + Antenna Factor (dB/m) - Pre\_Amplifier Gain (dB)



Site: AC102	Time: 2016/08/10 - 17:39
Limit: FCC_Part15.209_RE(3m)	Margin: 0
Probe: BBHA 9120D(1-18GHz)	Polarity: Horizontal
EUT: IP3M-941W/941B	Power: AC 120V/60Hz
Note: Mode4: Transmit at Channel 5230MHz by 802.11n40	

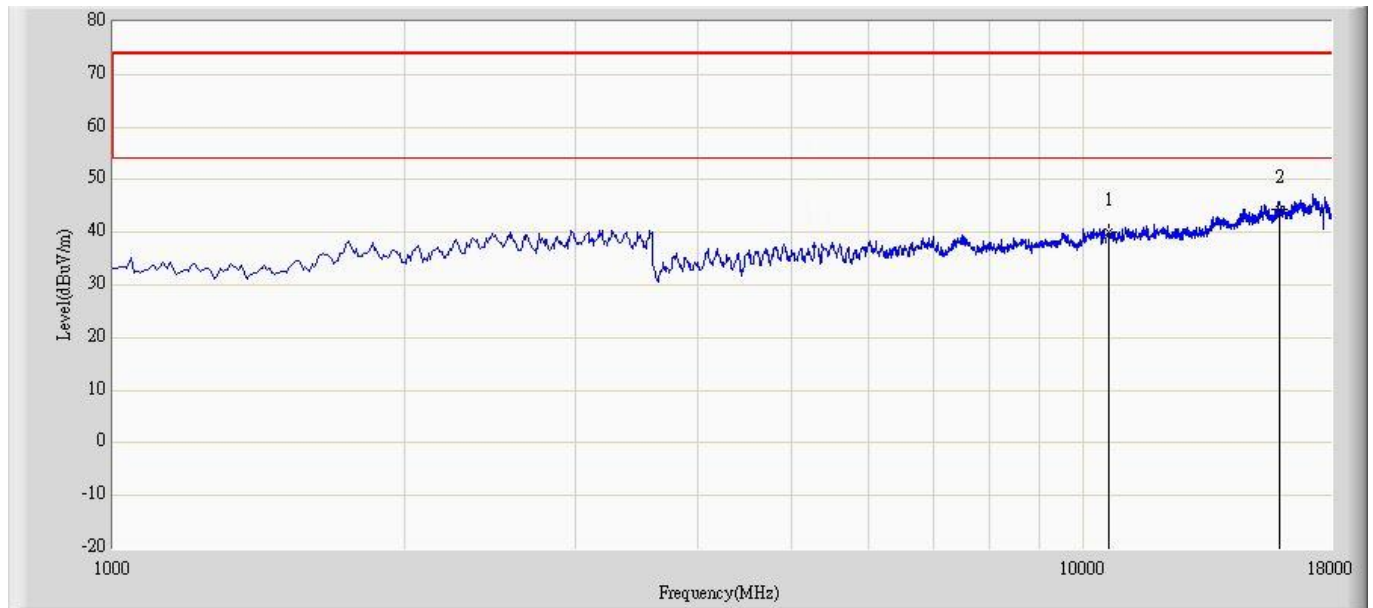

No	Flag	Mark	Frequency (MHz)	Measure Level (dBuV/m)	Reading Level (dBuV)	Over Limit (dB)	Limit (dBuV/m)	Factor	Type
1			10460.000	39.949	25.827	-34.051	74.000	14.123	PK
2		*	15690.000	44.245	21.202	-29.755	74.000	23.043	PK

Note: Measure Level (dBuV/m) = Reading Level (dBuV) + Factor (dB)

Factor (dB) = Cable Loss (dB) + Antenna Factor (dB/m) - Pre\_Amplifier Gain (dB)



Site: AC102	Time: 2016/08/10 - 17:40
Limit: FCC_Part15.209_RE(3m)	Margin: 0
Probe: BBHA 9120D(1-18GHz)	Polarity: Vertical
EUT: IP3M-941W/941B	Power: AC 120V/60Hz
Note: Mode4: Transmit at Channel 5230MHz by 802.11n40	

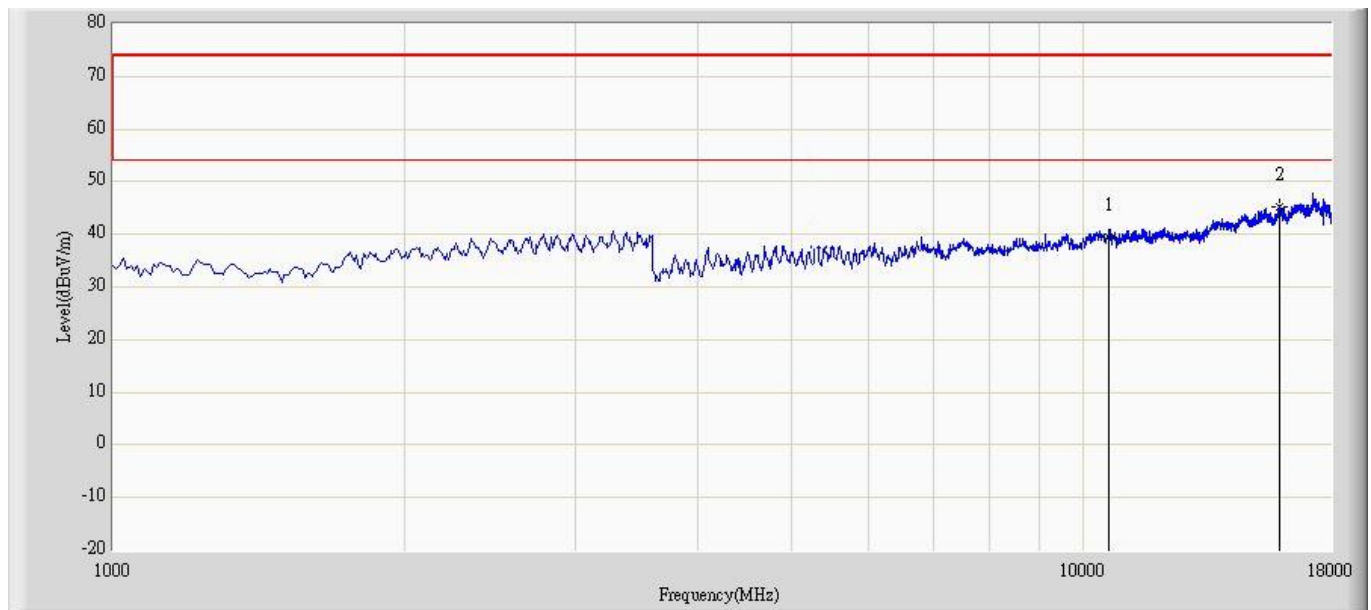

No	Flag	Mark	Frequency (MHz)	Measure Level (dBuV/m)	Reading Level (dBuV)	Over Limit (dB)	Limit (dBuV/m)	Factor	Type
1			10460.000	39.375	25.253	-34.625	74.000	14.123	PK
2		*	15690.000	45.151	21.892	-28.849	74.000	23.259	PK

Note: Measure Level (dBuV/m) = Reading Level (dBuV) + Factor (dB)

Factor (dB) = Cable Loss (dB) + Antenna Factor (dB/m) - Pre\_Amplifier Gain (dB)



Site: AC102	Time: 2016/08/10 - 17:42
Limit: FCC_Part15.209_RE(3m)	Margin: 0
Probe: BBHA 9120D(1-18GHz)	Polarity: Horizontal
EUT: IP3M-941W/941B	Power: AC 120V/60Hz
Note: Mode4: Transmit at Channel 5755MHz by 802.11n40	

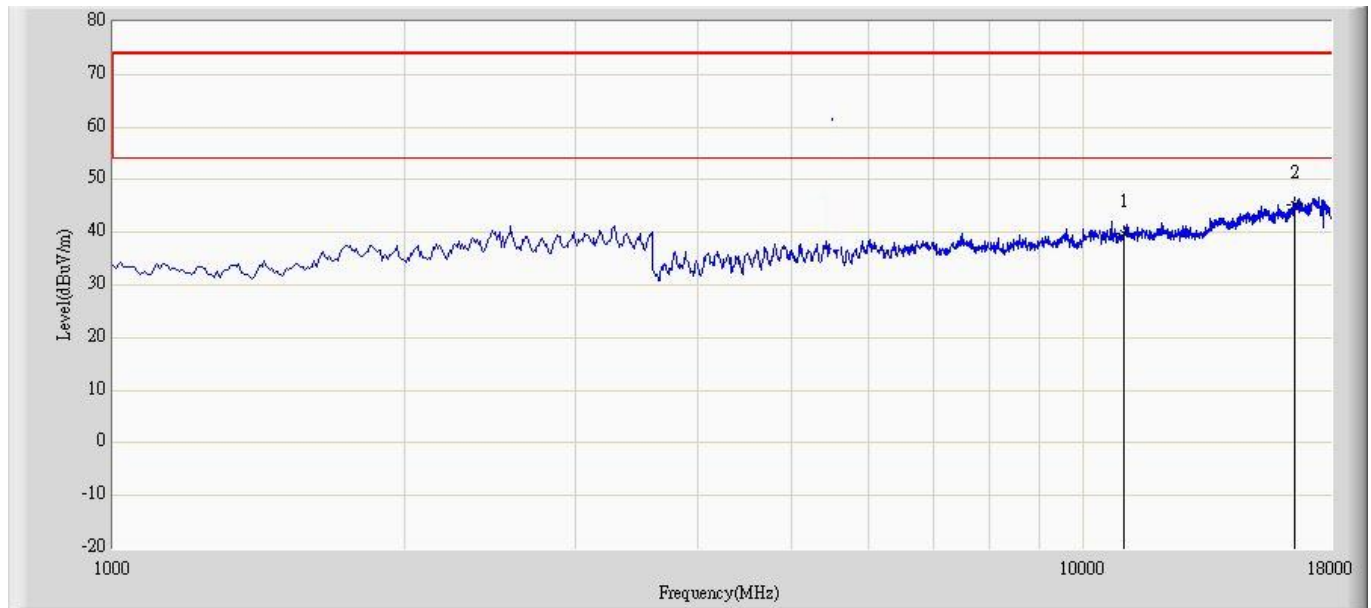

No	Flag	Mark	Frequency (MHz)	Measure Level (dBuV/m)	Reading Level (dBuV)	Over Limit (dB)	Limit (dBuV/m)	Factor	Type
1			11510.000	39.815	24.825	-34.185	74.000	14.990	PK
2		*	17265.000	45.301	23.060	-28.699	74.000	22.242	PK

Note: Measure Level (dBuV/m) = Reading Level (dBuV) + Factor (dB)

Factor (dB) = Cable Loss (dB) + Antenna Factor (dB/m) - Pre\_Amplifier Gain (dB)



Site: AC102	Time: 2016/08/10 - 17:43
Limit: FCC_Part15.209_RE(3m)	Margin: 0
Probe: BBHA 9120D(1-18GHz)	Polarity: Vertical
EUT: IP3M-941W/941B	Power: AC 120V/60Hz
Note: Mode4: Transmit at Channel 5755MHz by 802.11n40	

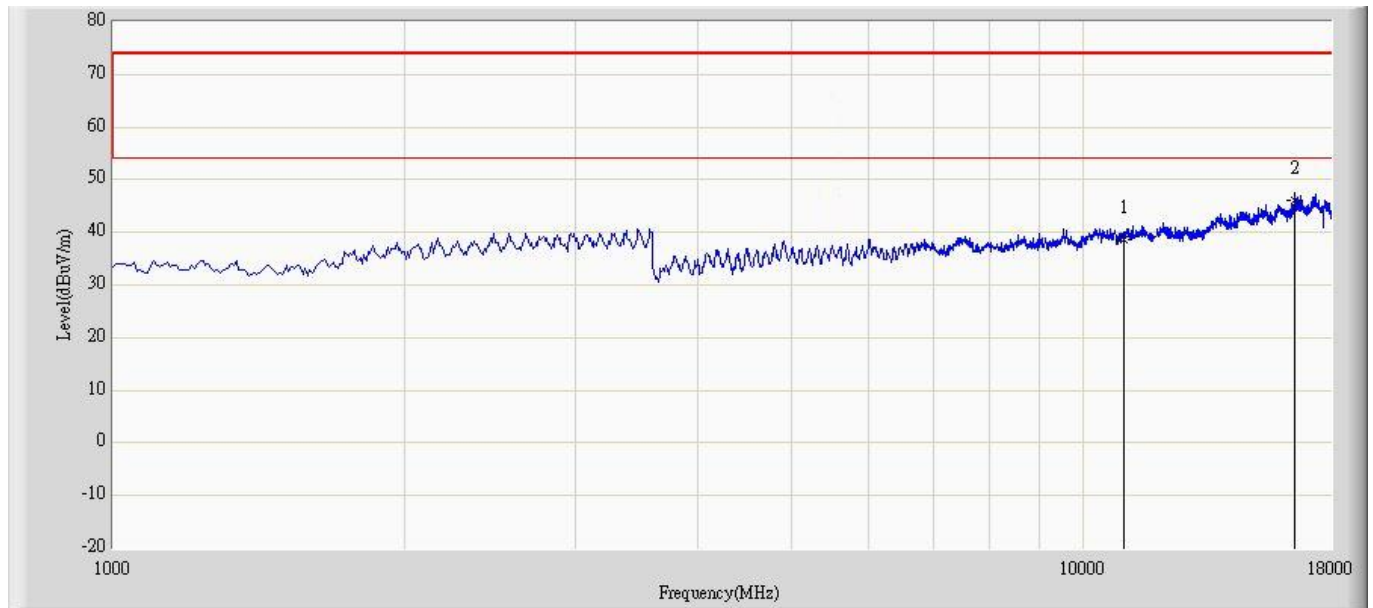

No	Flag	Mark	Frequency (MHz)	Measure Level (dBuV/m)	Reading Level (dBuV)	Over Limit (dB)	Limit (dBuV/m)	Factor	Type
1			11510.000	38.605	23.623	-35.395	74.000	14.982	PK
2		*	17265.000	45.968	23.627	-28.032	74.000	22.342	PK

Note: Measure Level (dBuV/m) = Reading Level (dBuV) + Factor (dB)

Factor (dB) = Cable Loss (dB) + Antenna Factor (dB/m) - Pre\_Amplifier Gain (dB)





Site: AC102	Time: 2016/08/10 - 17:48
Limit: FCC_Part15.209_RE(3m)	Margin: 0
Probe: BBHA 9120D(1-18GHz)	Polarity: Horizontal
EUT: IP3M-941W/941B	Power: AC 120V/60Hz
Note: Mode4: Transmit at Channel 5795MHz by 802.11n40	

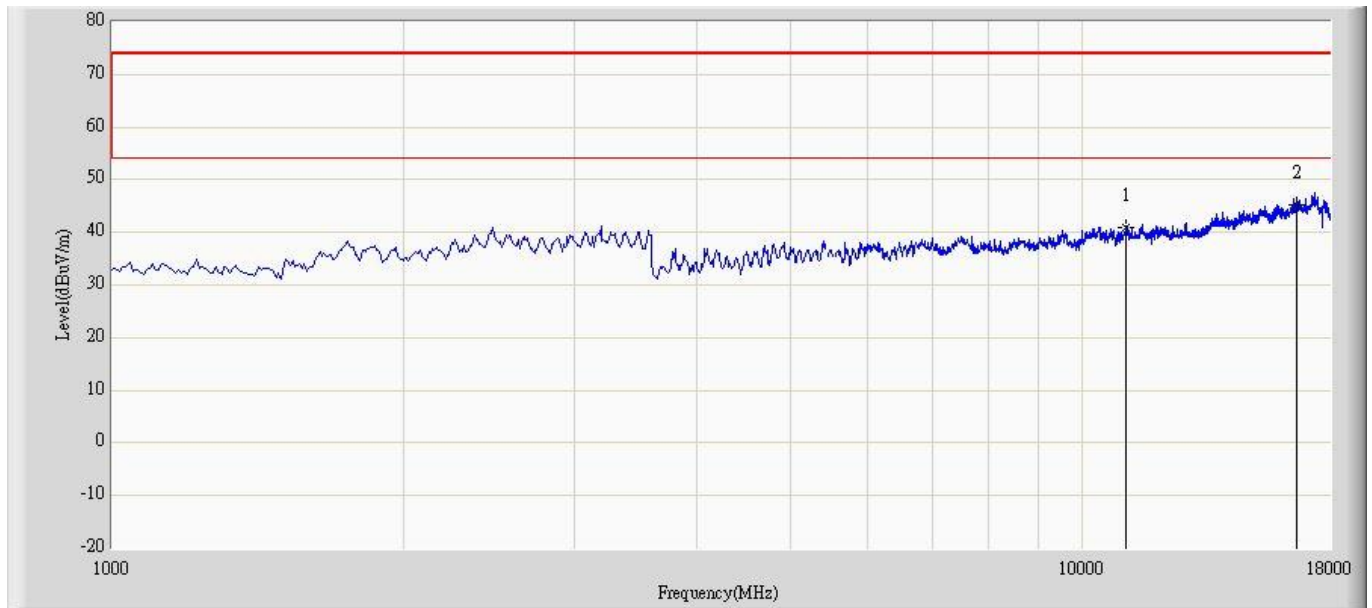

No	Flag	Mark	Frequency (MHz)	Measure Level (dBuV/m)	Reading Level (dBuV)	Over Limit (dB)	Limit (dBuV/m)	Factor	Type
1			11590.000	40.884	25.585	-33.116	74.000	15.298	PK
2		*	17385.000	45.142	22.590	-28.858	74.000	22.552	PK

Note: Measure Level (dBuV/m) = Reading Level (dBuV) + Factor (dB)

Factor (dB) = Cable Loss (dB) + Antenna Factor (dB/m) - Pre\_Amplifier Gain (dB)



Site: AC102	Time: 2016/08/10 - 17:49
Limit: FCC_Part15.209_RE(3m)	Margin: 0
Probe: BBHA 9120D(1-18GHz)	Polarity: Vertical
EUT: IP3M-941W/941B	Power: AC 120V/60Hz
Note: Mode4: Transmit at Channel 5795MHz by 802.11n40	

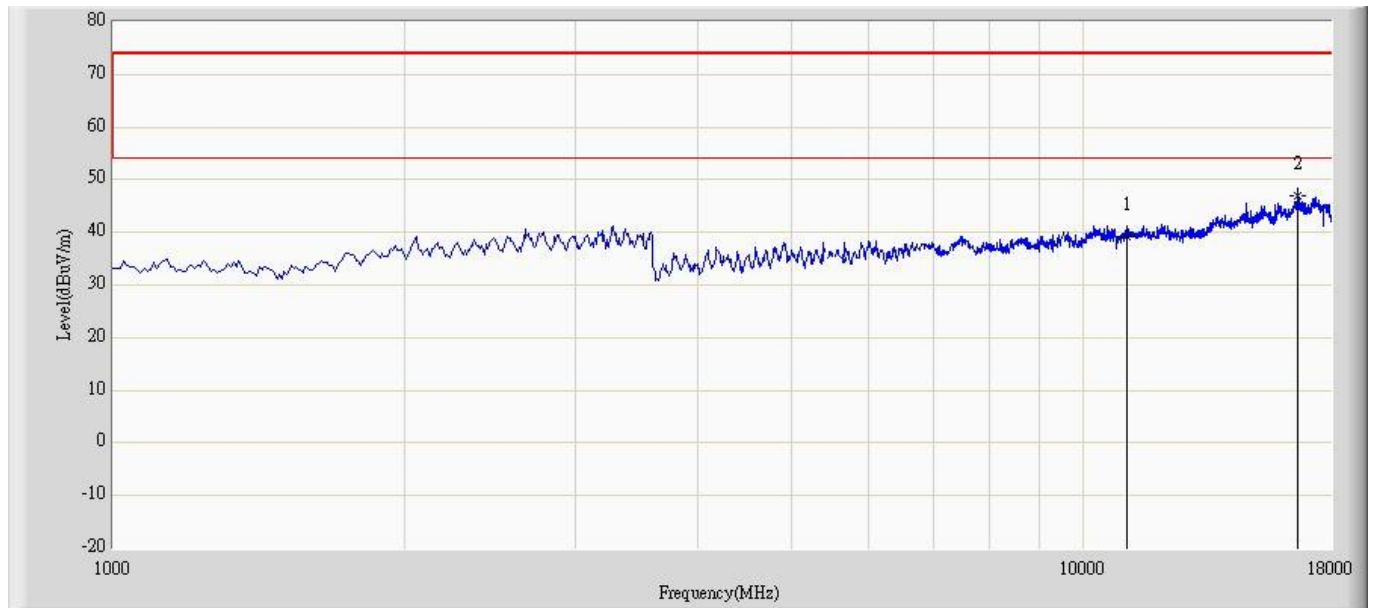

No	Flag	Mark	Frequency (MHz)	Measure Level (dBuV/m)	Reading Level (dBuV)	Over Limit (dB)	Limit (dBuV/m)	Factor	Type
1			11590.000	39.130	23.872	-34.870	74.000	15.258	PK
2		*	17385.000	47.069	24.417	-26.931	74.000	22.652	PK

Note: Measure Level (dBuV/m) = Reading Level (dBuV) + Factor (dB)

Factor (dB) = Cable Loss (dB) + Antenna Factor (dB/m) - Pre\_Amplifier Gain (dB)



Site: AC102	Time: 2016/08/10 - 17:54
Limit: FCC_Part15.209_RE(3m)	Margin: 0
Probe: BBHA 9120D(1-18GHz)	Polarity: Horizontal
EUT: IP3M-941W/941B	Power: AC 120V/60Hz
Note: Mode5: Transmit at Channel 5190MHz by 802.11ac40	

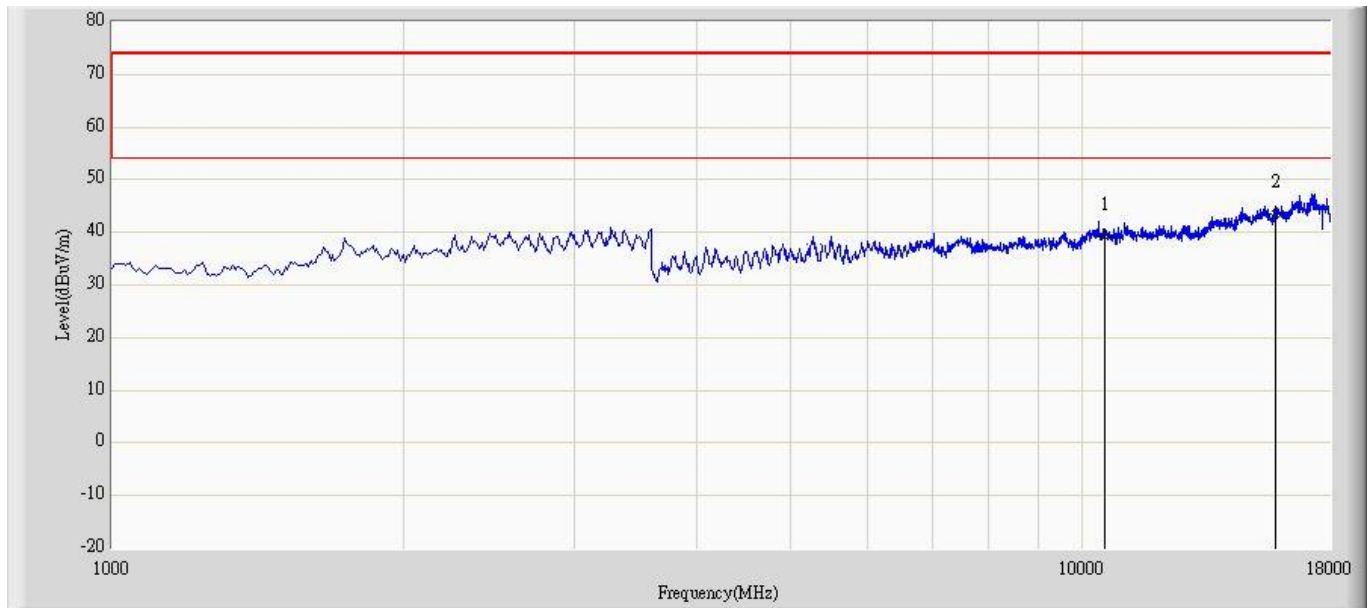

No	Flag	Mark	Frequency (MHz)	Measure Level (dBuV/m)	Reading Level (dBuV)	Over Limit (dB)	Limit (dBuV/m)	Factor	Type
1			10380.000	39.231	25.231	-34.769	74.000	13.999	PK
2		*	15570.000	43.395	20.453	-30.605	74.000	22.943	PK

Note: Measure Level (dBuV/m) = Reading Level (dBuV) + Factor (dB)

Factor (dB) = Cable Loss (dB) + Antenna Factor (dB/m) - Pre\_Amplifier Gain (dB)



Site: AC102	Time: 2016/08/10 - 17:55
Limit: FCC_Part15.209_RE(3m)	Margin: 0
Probe: BBHA 9120D(1-18GHz)	Polarity: Vertical
EUT: IP3M-941W/941B	Power: AC 120V/60Hz
Note: Mode5: Transmit at Channel 5190MHz by 802.11ac40	

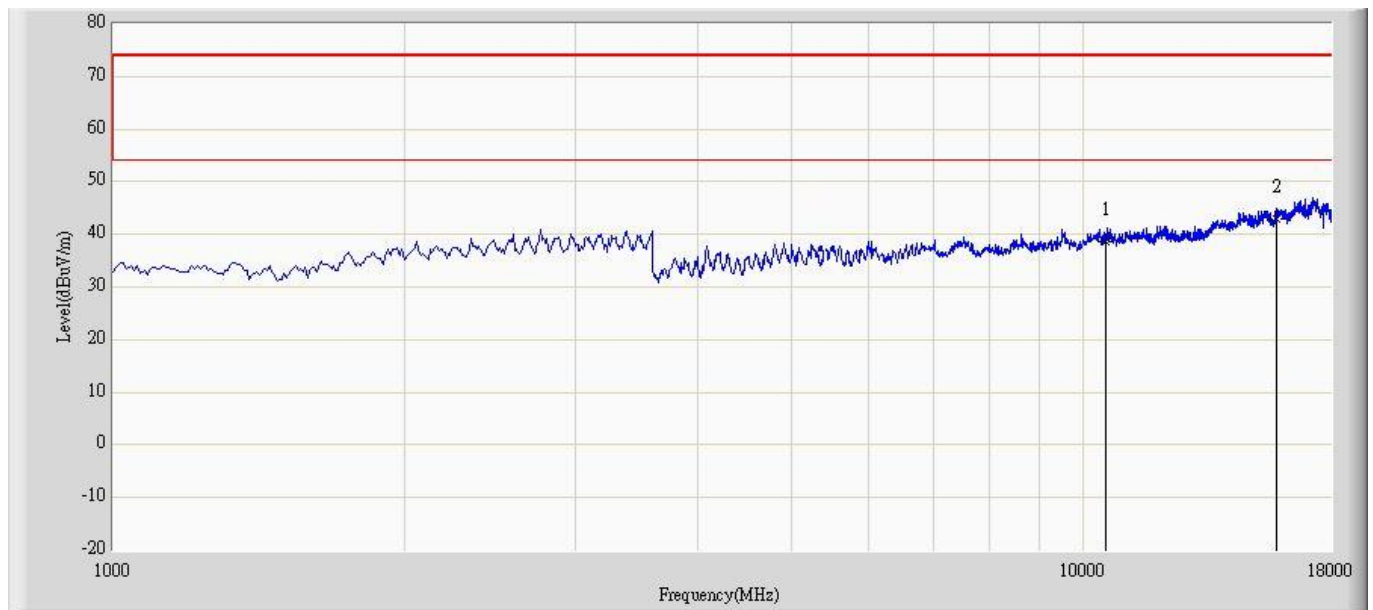

No	Flag	Mark	Frequency (MHz)	Measure Level (dBuV/m)	Reading Level (dBuV)	Over Limit (dB)	Limit (dBuV/m)	Factor	Type
1			10380.000	38.728	24.728	-35.272	74.000	13.999	PK
2		*	15570.000	42.892	19.877	-31.108	74.000	23.015	PK

Note: Measure Level (dBuV/m) = Reading Level (dBuV) + Factor (dB)

Factor (dB) = Cable Loss (dB) + Antenna Factor (dB/m) - Pre\_Amplifier Gain (dB)



Site: AC102	Time: 2016/08/10 - 17:56
Limit: FCC_Part15.209_RE(3m)	Margin: 0
Probe: BBHA 9120D(1-18GHz)	Polarity: Horizontal
EUT: IP3M-941W/941B	Power: AC 120V/60Hz
Note: Mode5: Transmit at Channel 5230MHz by 802.11ac40	

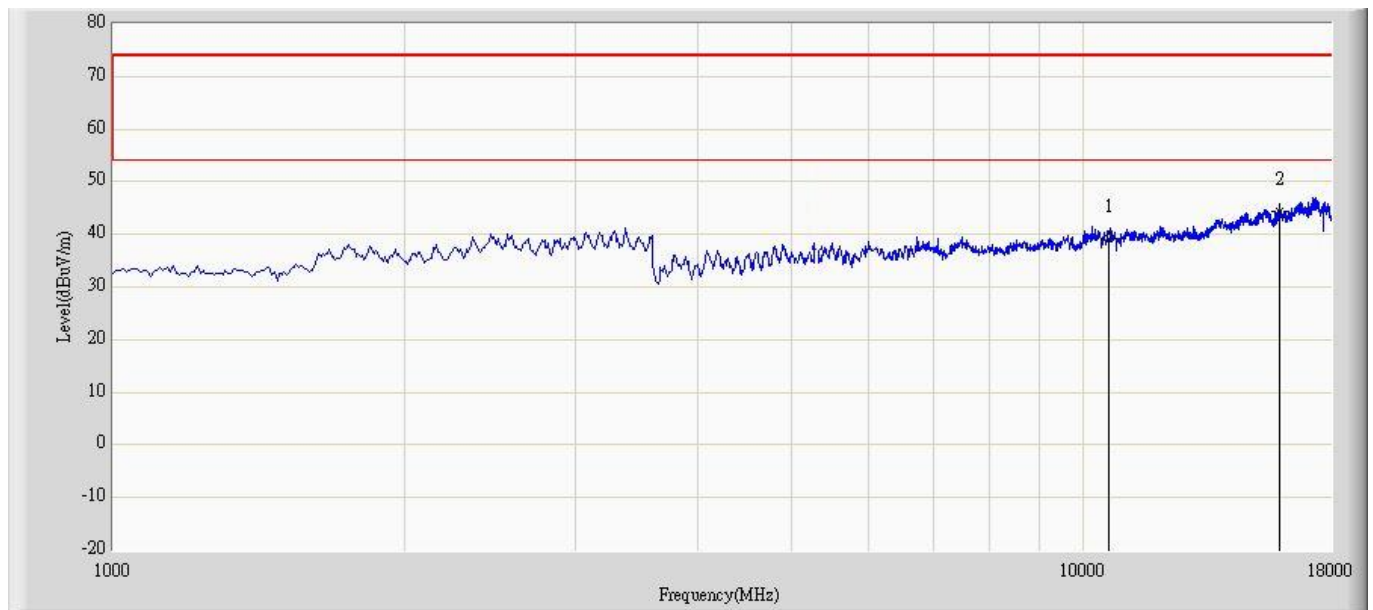

No	Flag	Mark	Frequency (MHz)	Measure Level (dBuV/m)	Reading Level (dBuV)	Over Limit (dB)	Limit (dBuV/m)	Factor	Type
1			10460.000	39.143	25.021	-34.857	74.000	14.123	PK
2		*	15690.000	44.485	21.442	-29.515	74.000	23.043	PK

Note: Measure Level (dBuV/m) = Reading Level (dBuV) + Factor (dB)

Factor (dB) = Cable Loss (dB) + Antenna Factor (dB/m) - Pre\_Amplifier Gain (dB)



Site: AC102	Time: 2016/08/10 - 17:57
Limit: FCC_Part15.209_RE(3m)	Margin: 0
Probe: BBHA 9120D(1-18GHz)	Polarity: Vertical
EUT: IP3M-941W/941B	Power: AC 120V/60Hz
Note: Mode5: Transmit at Channel 5230MHz by 802.11ac40	

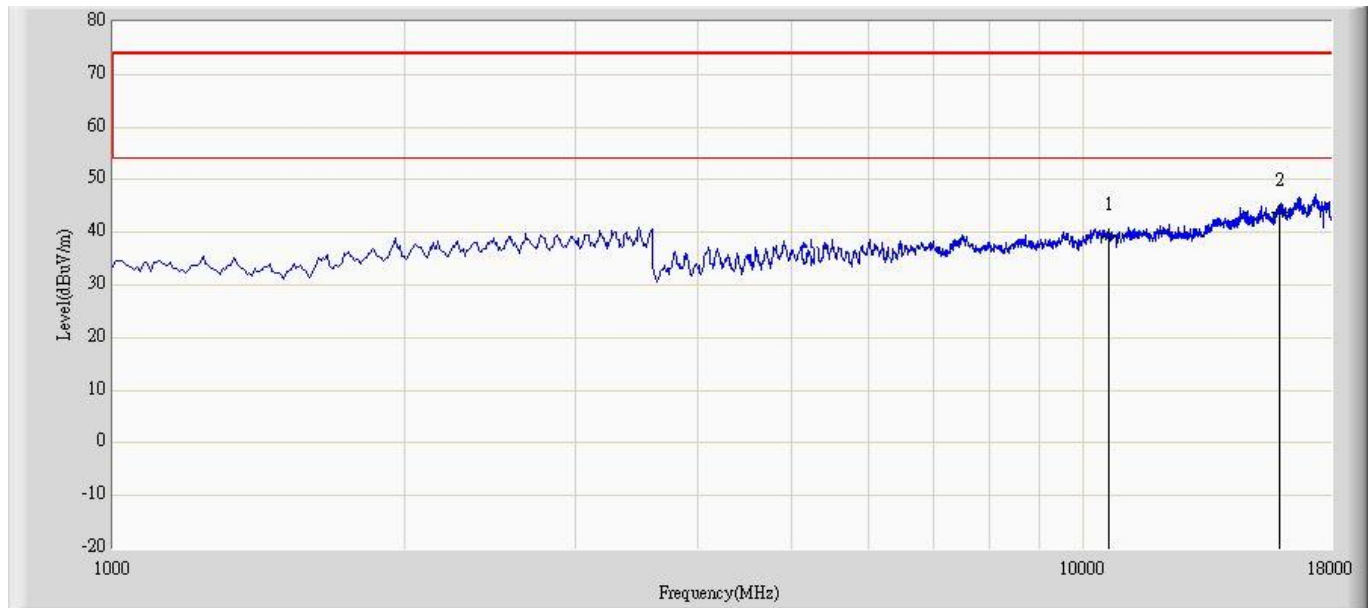

No	Flag	Mark	Frequency (MHz)	Measure Level (dBuV/m)	Reading Level (dBuV)	Over Limit (dB)	Limit (dBuV/m)	Factor	Type
1			10460.000	39.251	25.129	-34.749	74.000	14.123	PK
2		*	15690.000	43.899	20.640	-30.101	74.000	23.259	PK

Note: Measure Level (dBuV/m) = Reading Level (dBuV) + Factor (dB)

Factor (dB) = Cable Loss (dB) + Antenna Factor (dB/m) - Pre\_Amplifier Gain (dB)



Site: AC102	Time: 2016/08/10 - 17:59
Limit: FCC_Part15.209_RE(3m)	Margin: 0
Probe: BBHA 9120D(1-18GHz)	Polarity: Horizontal
EUT: IP3M-941W/941B	Power: AC 120V/60Hz
Note: Mode5: Transmit at Channel 5755MHz by 802.11ac40	

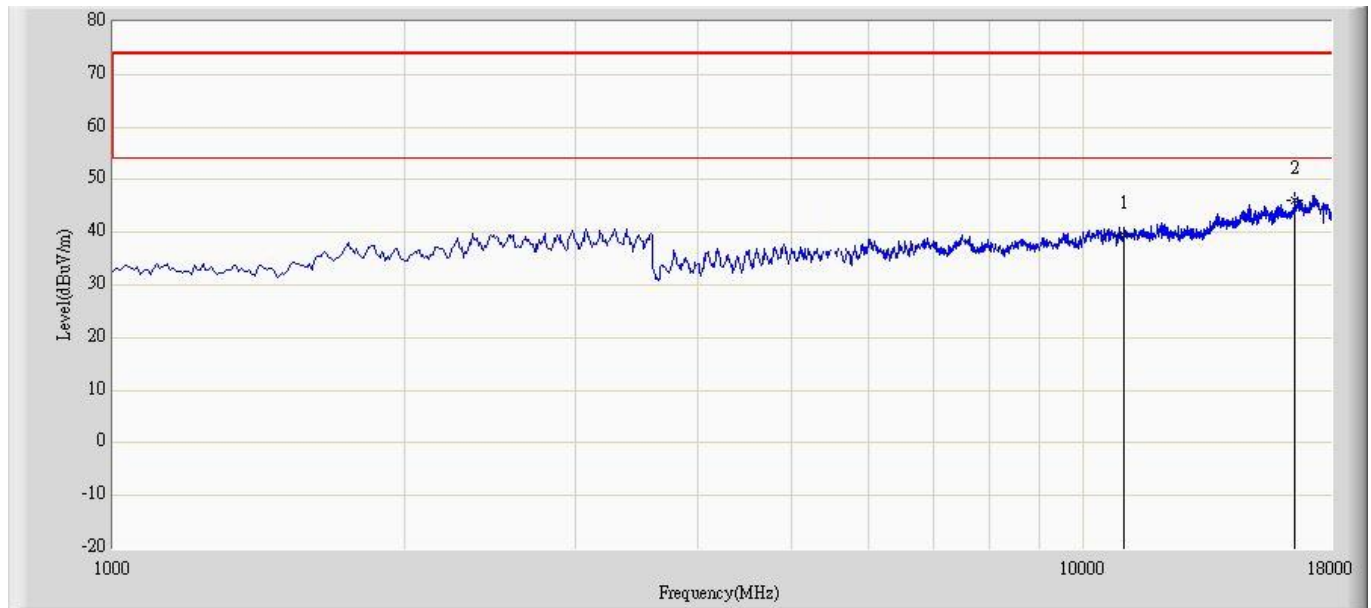

No	Flag	Mark	Frequency (MHz)	Measure Level (dBuV/m)	Reading Level (dBuV)	Over Limit (dB)	Limit (dBuV/m)	Factor	Type
1			11510.000	39.385	24.395	-34.615	74.000	14.990	PK
2		*	17265.000	46.218	23.977	-27.782	74.000	22.242	PK

Note: Measure Level (dBuV/m) = Reading Level (dBuV) + Factor (dB)

Factor (dB) = Cable Loss (dB) + Antenna Factor (dB/m) - Pre\_Amplifier Gain (dB)



Site: AC102	Time: 2016/08/10 - 18:00
Limit: FCC_Part15.209_RE(3m)	Margin: 0
Probe: BBHA 9120D(1-18GHz)	Polarity: Vertical
EUT: IP3M-941W/941B	Power: AC 120V/60Hz
Note: Mode5: Transmit at Channel 5755MHz by 802.11ac40	

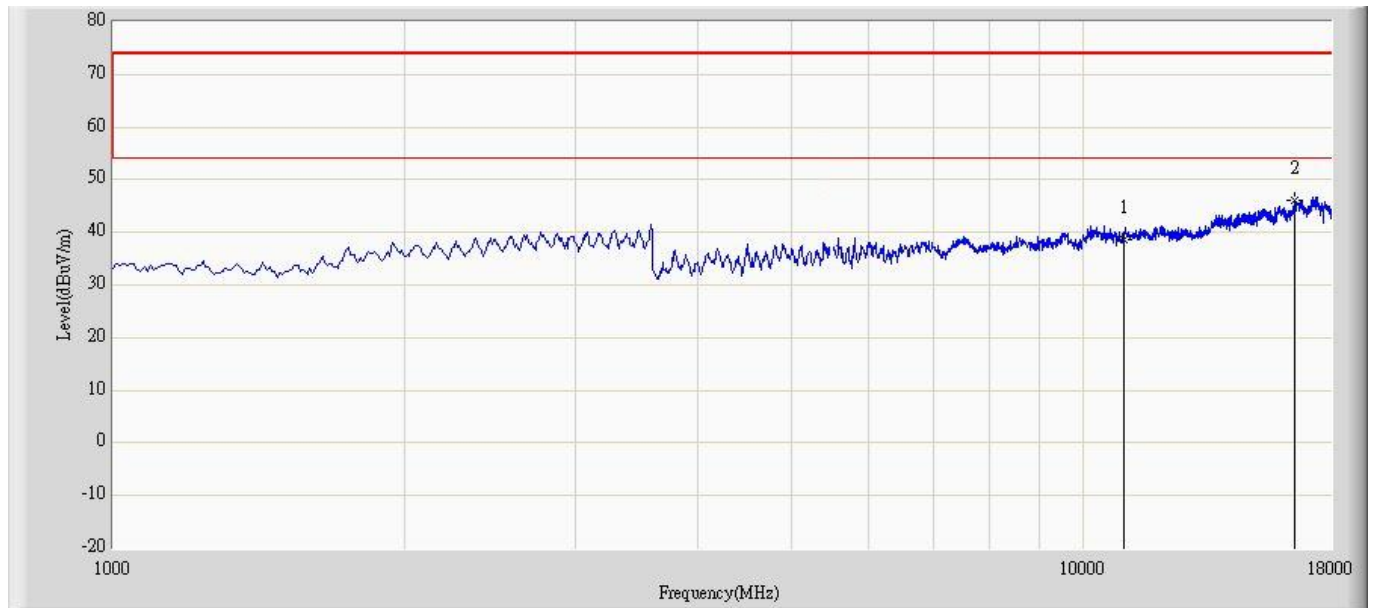

No	Flag	Mark	Frequency (MHz)	Measure Level (dBuV/m)	Reading Level (dBuV)	Over Limit (dB)	Limit (dBuV/m)	Factor	Type
1			11510.000	38.700	23.718	-35.300	74.000	14.982	PK
2		*	17265.000	46.163	23.822	-27.837	74.000	22.342	PK

Note: Measure Level (dBuV/m) = Reading Level (dBuV) + Factor (dB)

Factor (dB) = Cable Loss (dB) + Antenna Factor (dB/m) - Pre\_Amplifier Gain (dB)





Site: AC102	Time: 2016/08/10 - 18:01
Limit: FCC_Part15.209_RE(3m)	Margin: 0
Probe: BBHA 9120D(1-18GHz)	Polarity: Horizontal
EUT: IP3M-941W/941B	Power: AC 120V/60Hz
Note: Mode5: Transmit at Channel 5795MHz by 802.11ac40	

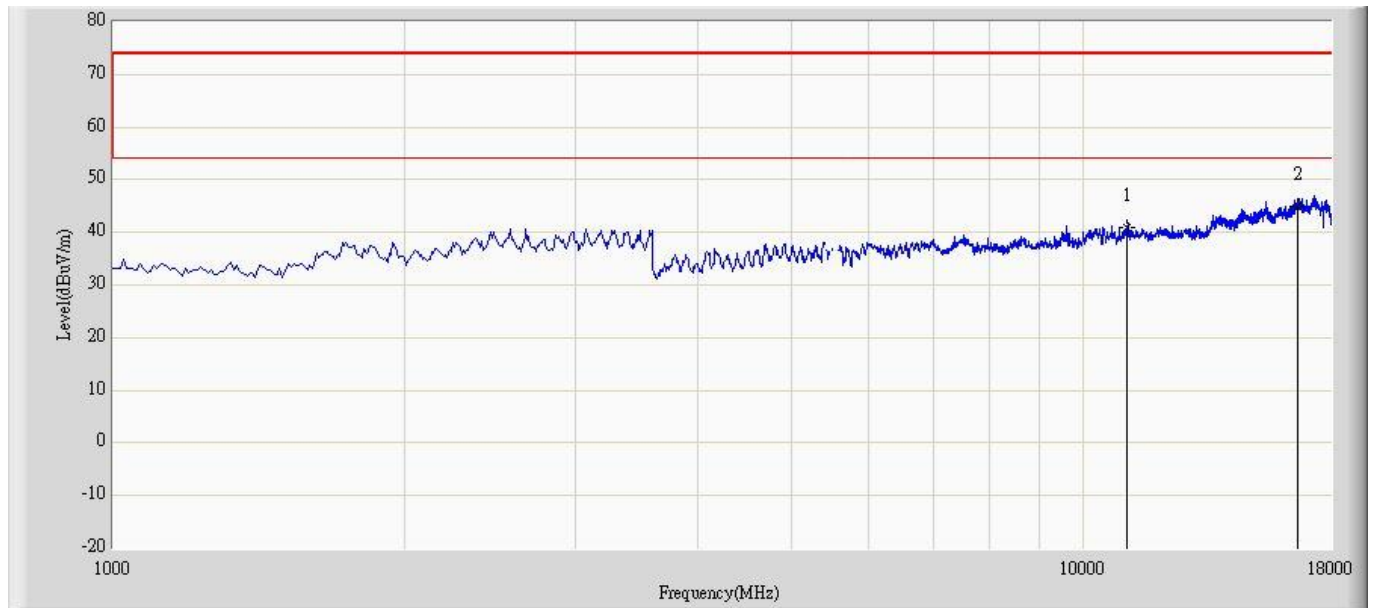

No	Flag	Mark	Frequency (MHz)	Measure Level (dBuV/m)	Reading Level (dBuV)	Over Limit (dB)	Limit (dBuV/m)	Factor	Type
1			11590.000	41.059	25.760	-32.941	74.000	15.298	PK
2		*	17385.000	44.984	22.432	-29.016	74.000	22.552	PK

Note: Measure Level (dBuV/m) = Reading Level (dBuV) + Factor (dB)

Factor (dB) = Cable Loss (dB) + Antenna Factor (dB/m) - Pre\_Amplifier Gain (dB)



Site: AC102	Time: 2016/08/10 - 18:02
Limit: FCC_Part15.209_RE(3m)	Margin: 0
Probe: BBHA 9120D(1-18GHz)	Polarity: Vertical
EUT: IP3M-941W/941B	Power: AC 120V/60Hz
Note: Mode5: Transmit at Channel 5795MHz by 802.11ac40	

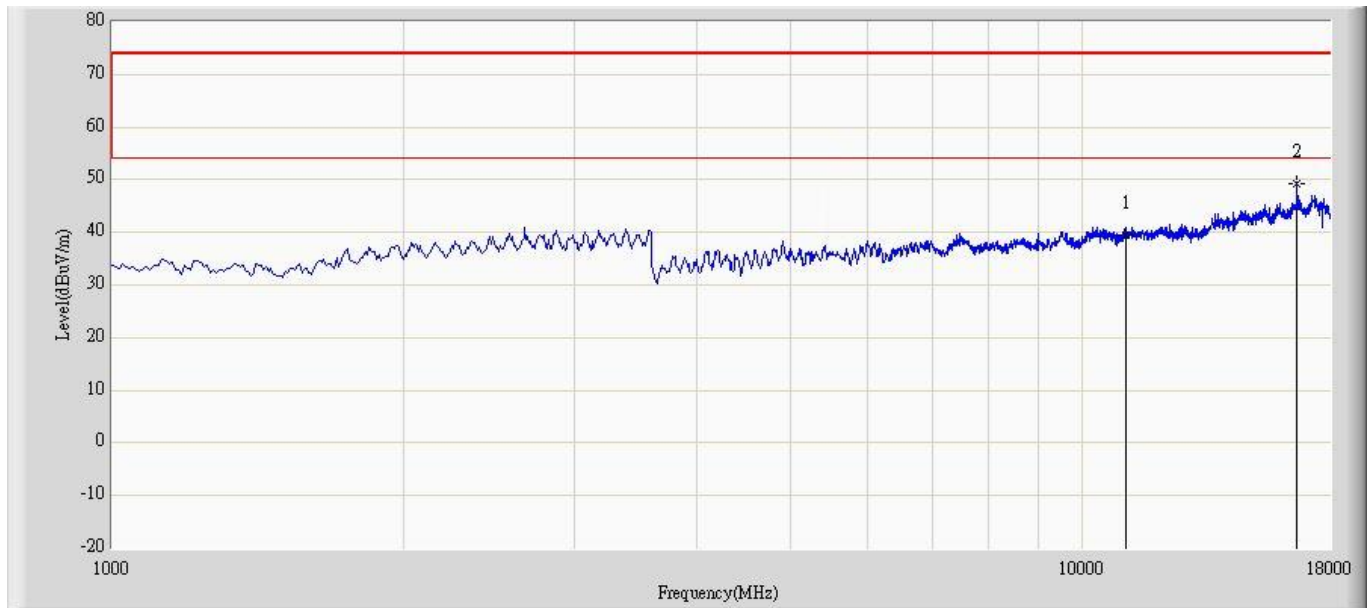

No	Flag	Mark	Frequency (MHz)	Measure Level (dBuV/m)	Reading Level (dBuV)	Over Limit (dB)	Limit (dBuV/m)	Factor	Type
1			11590.000	39.519	24.261	-34.481	74.000	15.258	PK
2		*	17385.000	49.121	26.469	-24.879	74.000	22.652	PK

Note: Measure Level (dBuV/m) = Reading Level (dBuV) + Factor (dB)

Factor (dB) = Cable Loss (dB) + Antenna Factor (dB/m) - Pre\_Amplifier Gain (dB)



Site: AC102	Time: 2016/08/10 - 18:06
Limit: FCC_Part15.209_RE(3m)	Margin: 0
Probe: BBHA 9120D(1-18GHz)	Polarity: Horizontal
EUT: IP3M-941W/941B	Power: AC 120V/60Hz
Note: Mode6: Transmit at Channel 5210MHz by 802.11ac80	

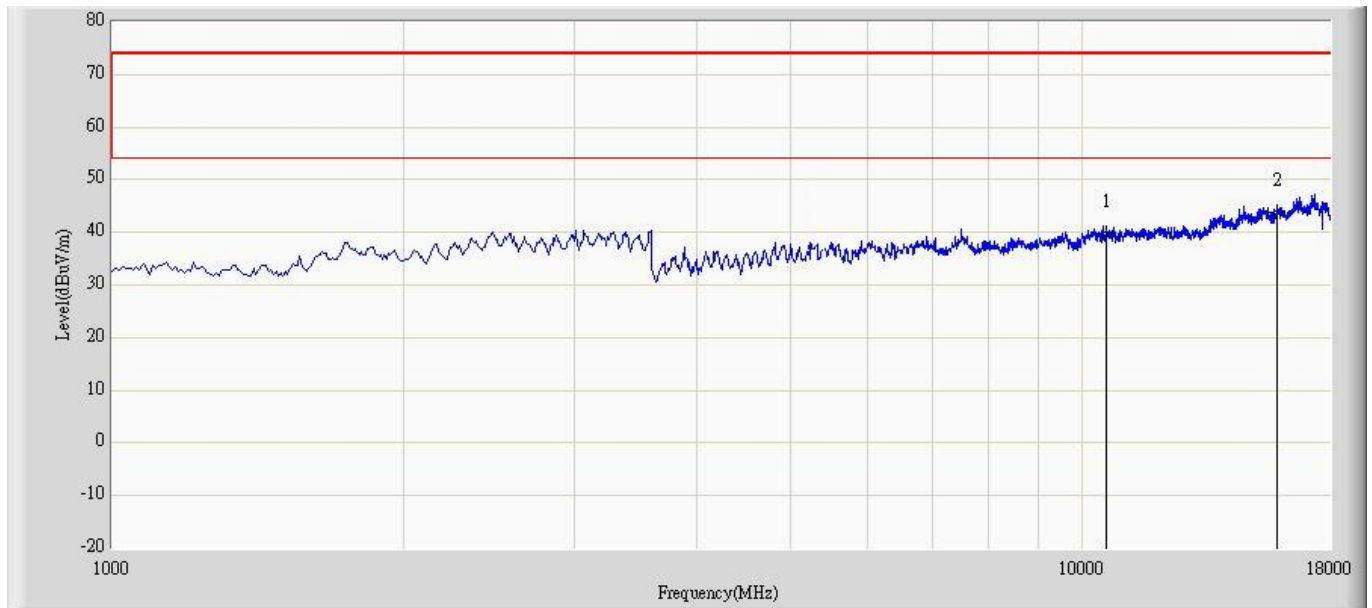

No	Flag	Mark	Frequency (MHz)	Measure Level (dBuV/m)	Reading Level (dBuV)	Over Limit (dB)	Limit (dBuV/m)	Factor	Type
1			10420.000	39.851	25.843	-34.149	74.000	14.008	PK
2		*	15630.000	43.786	20.757	-30.214	74.000	23.029	PK

Note: Measure Level (dBuV/m) = Reading Level (dBuV) + Factor (dB)

Factor (dB) = Cable Loss (dB) + Antenna Factor (dB/m) - Pre\_Amplifier Gain (dB)



Site: AC102	Time: 2016/08/10 - 18:07
Limit: FCC_Part15.209_RE(3m)	Margin: 0
Probe: BBHA 9120D(1-18GHz)	Polarity: Vertical
EUT: IP3M-941W/941B	Power: AC 120V/60Hz
Note: Mode6: Transmit at Channel 5210MHz by 802.11ac80	

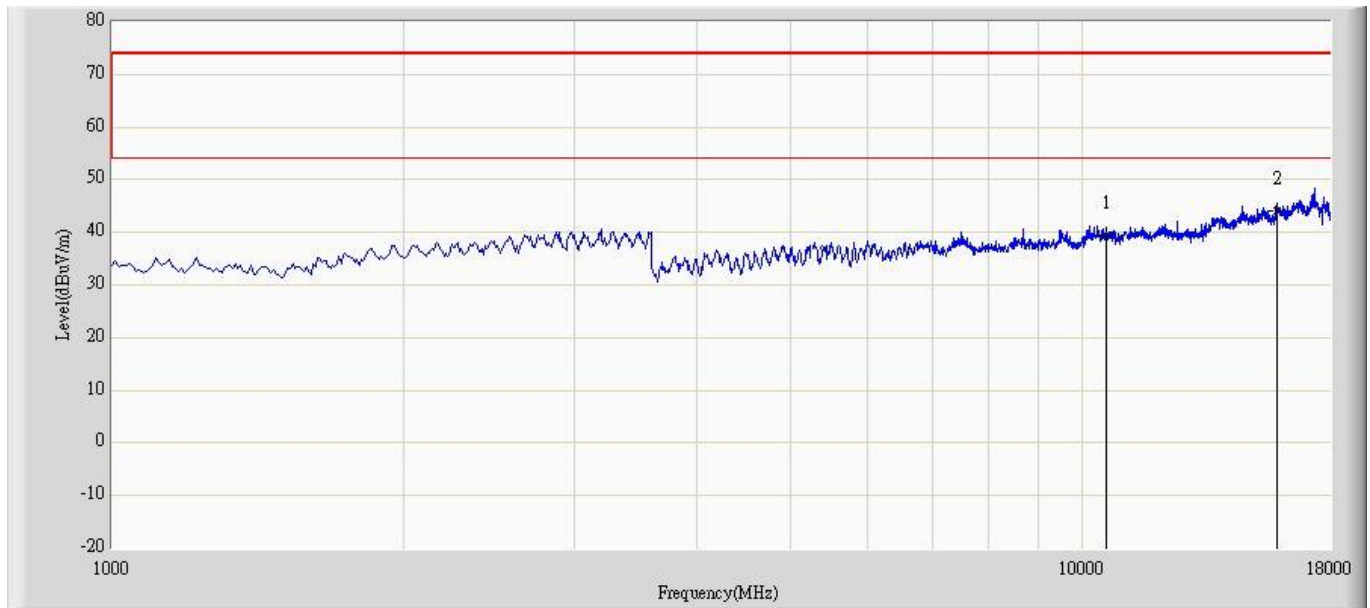

No	Flag	Mark	Frequency (MHz)	Measure Level (dBuV/m)	Reading Level (dBuV)	Over Limit (dB)	Limit (dBuV/m)	Factor	Type
1			10420.000	39.586	25.578	-34.414	74.000	14.008	PK
2		*	15630.000	44.021	20.848	-29.979	74.000	23.173	PK

Note: Measure Level (dBuV/m) = Reading Level (dBuV) + Factor (dB)

Factor (dB) = Cable Loss (dB) + Antenna Factor (dB/m) - Pre\_Amplifier Gain (dB)



Site: AC102	Time: 2016/08/10 - 18:08
Limit: FCC_Part15.209_RE(3m)	Margin: 0
Probe: BBHA 9120D(1-18GHz)	Polarity: Horizontal
EUT: IP3M-941W/941B	Power: AC 120V/60Hz
Note: Mode6: Transmit at Channel 5775MHz by 802.11ac80	

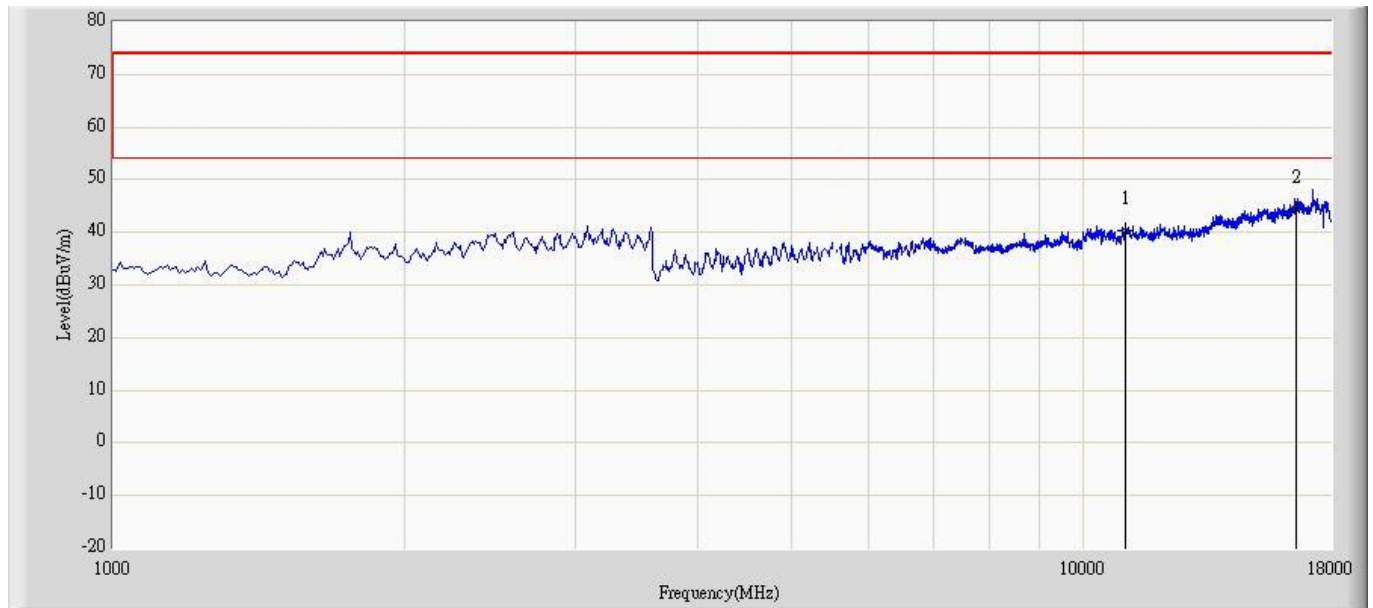

No	Flag	Mark	Frequency (MHz)	Measure Level (dBuV/m)	Reading Level (dBuV)	Over Limit (dB)	Limit (dBuV/m)	Factor	Type
1			11550.000	40.472	25.313	-33.528	74.000	15.160	PK
2		*	17325.000	44.342	21.866	-29.658	74.000	22.476	PK

Note: Measure Level (dBuV/m) = Reading Level (dBuV) + Factor (dB)

Factor (dB) = Cable Loss (dB) + Antenna Factor (dB/m) - Pre\_Amplifier Gain (dB)



Site: AC102	Time: 2016/08/10 - 18:09
Limit: FCC_Part15.209_RE(3m)	Margin: 0
Probe: BBHA 9120D(1-18GHz)	Polarity: Vertical
EUT: IP3M-941W/941B	Power: AC 120V/60Hz
Note: Mode6: Transmit at Channel 5775MHz by 802.11ac80	

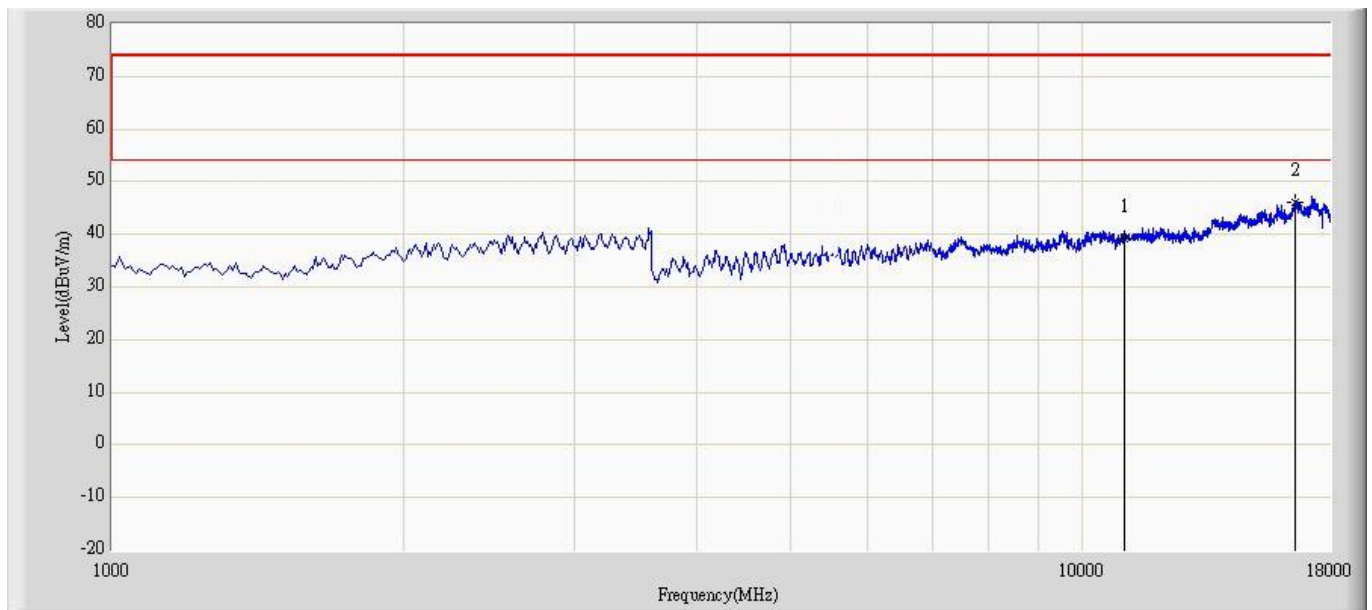

No	Flag	Mark	Frequency (MHz)	Measure Level (dBuV/m)	Reading Level (dBuV)	Over Limit (dB)	Limit (dBuV/m)	Factor	Type
1			11550.000	39.305	24.170	-34.695	74.000	15.136	PK
2		*	17325.000	46.060	23.484	-27.940	74.000	22.576	PK

Note: Measure Level (dBuV/m) = Reading Level (dBuV) + Factor (dB)

Factor (dB) = Cable Loss (dB) + Antenna Factor (dB/m) - Pre\_Amplifier Gain (dB)



## 5. Occupied Bandwidth

### 5.1 Test Equipment

Instrument	Manufacturer	Type No.	Serial No.	Calibration Date	Valid Date.
Spectrum Analyzer	Agilent	N9010A	MY53400169	2014.11.03	2016.11.03
Temperature/ Humidity Meter	Zhicheng	ZC1-11	CEP-TH-003	20155.03.31	2016.03.30

Note: All equipments are calibrated with traceable calibrations. Each calibration is traceable to the national or international standards.

### 5.2 Test Setup

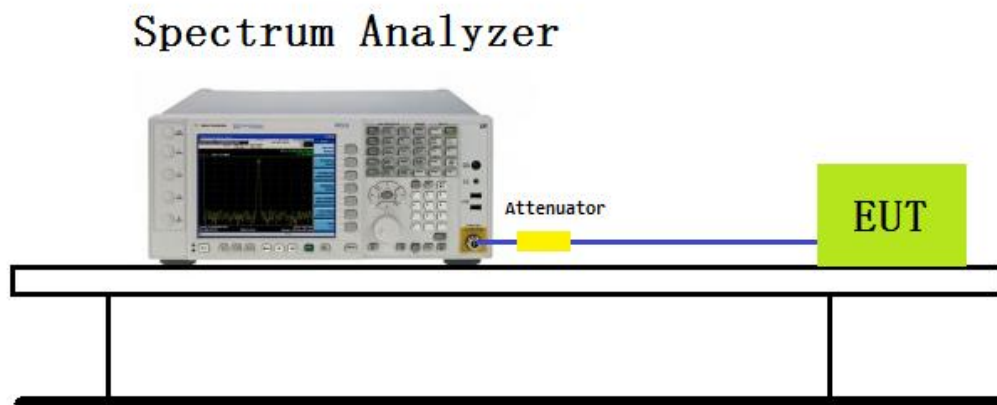

### 5.3 Test Limit

N/A



## 5.4 Test Procedure

The EUT was tested according to KDB 789033 D02v01r02-Section C.1 for compliance to FCC 47CFR 15.407 requirements.

### Emission Bandwidth

- Use a RBW = approximately 1% of the emission bandwidth.
- Set the VBW > RBW
- Detector = Peak.
- Trace mode = max hold.
- Measure the maximum width of the emission that is 26 dB down from the peak of the emission. Compare this with the RBW setting of the analyzer. Readjust RBW and repeat measurement as needed until the RBW/EBW ratio is approximately 1%.

### 99% Occupied Bandwidth

- Set center frequency to the nominal EUT channel center frequency.
- Set span = 1.5 times to 5.0 times the OBW.
- Set RBW = 1 % to 5 % of the OBW.
- Set VBW  $\geq 3 \cdot$  RBW.
- Video averaging is not permitted. Where practical, a sample detection and single sweep mode shall be used. Otherwise, peak detection and max hold mode (until the trace stabilizes) shall be used.
- Use the 99 % power bandwidth function of the instrument (if available).
- If the instrument does not have a 99 % power bandwidth function, the trace data points are recovered and directly summed in power units. The recovered amplitude data points, beginning at the lowest frequency, are placed in a running sum until 0.5 % of the total is reached; that frequency is recorded as the lower frequency. The process is repeated until 99.5 % of the total is reached; that frequency is recorded as the upper frequency. The 99% occupied bandwidth is the difference between these two frequencies.