



FCC/IC TEST REPORT

According to

FCC Rules and Regulations Part 15 Subpart E & RSS-247, Issue 2

Applicant : Amcrest Technologies LLC
Address : 16727 Park Row Dr.Houston, TX 77084
Manufacturer : Zhejiang Dahua Vision Technology Co., Ltd.
Address : No.1199, Bin'an road, Binjiang District, Hangzhou,P.R.China.
Equipment : 2K/3MP Dual-band Fixed Wireless IP Camera
Model No. : IP3M-HX2B , IP3M-HX2W
FCC ID : ZZ2AMC015
IC ID : 21923-AMC015
Test Period : Jul.26,2017~ Jul.31, 2017

- The test result refers exclusively to the test presented test model / sample.
- Without written approval of **Cerpass Technology Corporation Test Laboratory**, the test report shall not be reproduced exc- ept in full.
- The test report must not be used by the clients to claim product certification approval by any agency of the Government.

I HEREBY CERTIFY THAT :

The measurements shown in this test report were made in accordance with the procedures given in **ANSI C63.10 – 2013&RSS-247, Issue 2&RSS-Gen&FCC Part15.407** and the energy emitted by this equipment was **passed**.

Approved by:

Laboratory Accreditation:

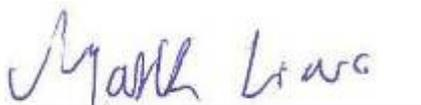

 Mark Liao / Assistant Manager



Cerpass Technology Corporation Test Laboratory

TAF LAB Code:	1439
----------------------	-------------



TABLE OF CONTENTS

1. Test Configuration of Equipment under Test	5
1.1 Feature of Equipment under Test	5
1.2 Description of Antenna	5
1.3 Working Frequencies.....	6
1.4 Power Parameter Value of the test software	7
1.5 Duty Cycle	8
1.6 Test Manner.....	9
2. Technical Test	10
2.1 Summary of Test Result	10
2.2 General Information of Test	13
2.3 Measuring Equipment	14
2.4 Measurement Uncertainty	15
3. Test of Conducted Emission	16
3.1 Test Limit	16
3.2 Test Standard.....	16
3.3 Test Procedures.....	16
3.4 Test Setup.....	17
3.5 Test Result and Data	18
4. Test of Radiated Emission	20
4.1 Test Limit.....	20
4.2 Test Standard	20
4.3 Test Procedures	21
4.4 Test Setup	22
4.5 Test Result and Data	24
5. 26dB Occupied Bandwidth	32
5.1 Test Limit	32
5.2 Test Standard.....	32
5.3 Test Procedures.....	33
5.4 Test Setup.....	34
5.5 Test Result and Data	35
6. 6dB Bandwidth Measurement	41
6.1 Test Limit	41
6.2 Test Standard.....	41
6.3 Test Procedures.....	41
6.4 Test Setup	41
6.5 Test Result and Data.....	42
7. Power Output	46
7.1 Test Limit	46
7.2 Test Standard.....	46
7.3 Test Procedures.....	47
7.4 Test Setup.....	47



7.5 Test Result and Data 48

8. Power Spectral Density..... 52

8.1 Test Limit 52

8.2 Test Standard..... 52

8.3 Test Procedures..... 53

8.4 Test Setup..... 53

8.5 Test Result and Data 54

9. Band Edges Measurement..... 59

9.1 Test Limit 59

9.2 Test Standard..... 61

9.3 Test Procedures..... 61

9.4 Test Setup..... 62

9.5 Test Result and Data 63

10.Frequency Stability..... 105

10.1 Test Limit 105

10.2 Test Standard..... 105

10.3 Test Procedures..... 105

10.4 Test Setup..... 106

10.5 Test Result and Data 107



History of this test report

Report No.	Version	Issue Date	Description
SEDL1708002	Rev.01	2017-08-16	Initial release
SEDL1708002	Rev.02	2017-10-23	Add RSS-247, Issue 2 standard
SEDL1708002	Rev.03	2017-10-24	Add EIRP Power



1. Test Configuration of Equipment under Test

1.1 Feature of Equipment under Test

Product Name	2K/3MP Dual-band Fixed Wireless IP Camera
Model No.	IP3M-HX2B,IP3M-HX2W
wireless Model No.	WIFI-2-R811USA2
Frequency Range	802.11a/n (20MHz): 5180~5250MHz, 5725~5850MHz 802.11n(40MHz): 5190~5230MHz, 5755~5795MHz 802.11ac(80MHz): 5210MHz,5775MHz
Type of Modulation	802.11a: BPSK, QPSK, 16QAM, 64QAM and OFDM 802.11n: BPSK, QPSK, 16QAM, 64QAM and OFDM 802.11ac: BPSK, QPSK, 16QAM, 64QAM, 256QAM and OFDM
Data Rate	802.11a: 6/9/12/18/24/36/48/54 Mbps 802.11n: MCS0~MCS7 802.11ac: up to 433.3 Mbps
Channel Control	Auto
Antenna Delivery	1*Tx + 1*Rx for 5GHz

1.2 Description of Antenna

Antenna	Peak Gain
PCB Antenna	5.2G: 1.99dBi,5.8G: 1.59dBi



1.3 Working Frequencies

802.11a/n(20MHz) Working Frequency of Each Channel:							
Channel	Frequency	Channel	Frequency	Channel	Frequency	Channel	Frequency
36	5180 MHz	40	5200 MHz	44	5220 MHz	48	5240 MHz
149	5745 MHz	153	5765 MHz	157	5785 MHz	161	5805 MHz
165	5825 MHz	N/A	N/A	N/A	N/A	N/A	N/A

802.11n(40MHz) Working Frequency of Each Channel:							
Channel	Frequency	Channel	Frequency	Channel	Frequency	Channel	Frequency
38	5190 MHz	46	5230 MHz	151	5755 MHz	159	5795 MHz

802.11ac(80MHz) Working Frequency of Each Channel:							
Channel	Frequency	Channel	Frequency	Channel	Frequency	Channel	Frequency
42	5210 MHz	155	5775 MHz	N/A	N/A	N/A	N/A



1.4 Power Parameter Value of the test software

Test Mode	Test Channel	Power Setting
802.11a	5180	63
	5220	63
	5240	63
	5745	63
	5785	63
	5825	63
802.11n(20MHz)	5180	63
	5220	63
	5240	63
	5745	63
	5785	63
	5825	63
802.11n(40MHz)	5190	63
	5230	63
	5755	63
	5795	63
802.11ac(80MHz)	5210	63
	5775	63



1.5 Duty Cycle

Test Mode	Frequency (MHz)	Duty Cycle
802.11a	5240	100%
802.11ac(20MHz)	5240	100%
802.11ac(40MHz)	5230	100%
802.11ac(80MHz)	5210	100%



1.6 Test Manner

Test Manner	
a	During testing, the interface cables and equipment positions were varied according to ANSI C63.10
b	Adjust the EUT at the test mode and the test channel. Then test.

Test Mode
Mode 1: Transmit by 802.11a
Mode 2: Transmit by 802.11n(20MHz)
Mode 3: Transmit by 802.11n(40MHz)
Mode 4: Transmit by 802.11ac(80MHz)

Note: Regards to the frequency band operation: the lowest, middle and highest frequency of channel were selected to perform the test, then shown on this report.



2. Technical Test

2.1 Summary of Test Result

No deviations from the test standards

Deviations from the test standards as below description:

FCC Part Section(s)	Test Description	Test Limit	Test Condition	Test Result	Reference
15.407(a)	26dB Bandwidth	N/A	Conducted	Pass	Section 7.2
15.407(e)	6dB Bandwidth	≥ 500KHz		Pass	Section 7.3
15.407(a)(1)(ii), (2), (3)	Maximum Conducted Output Power	≤ 30 dBm U-NII-1 ≤ 24 dBm U-NII-2A ≤ 24 dBm U-NII-2C ≤ 30 dBm U-NII-3		Pass	Section 7.4
15.407(h)(1)	Transmit Power Control	≤ 24 dBm		Pass	Section 7.5
15.407(a)(1)(ii), (2), (3), (5)	Peak Power Spectral Density	≤ 17 dBm/MHz U-NII-1 ≤ 11 dBm/MHz U-NII-2A ≤ 11 dBm/MHz U-NII-2C ≤ 30 dBm/500KHz U-NII-3		Pass	Section 7.6
15.407(g)	Frequency Stability	N/A		Pass	Section 7.7
15.407(b)(1), (2), (3), (4)	Undesirable Emissions	≤ -27dBm/MHz EIRP ≤ -17dBm/MHz EIRP		Radiated	Pass
15.205, 15.209 15.407(b)(5), (6), (7)	General Field Strength Limits (Restricted)	Emissions in restricted bands must meet the	Pass		Section 7.8 & 7.9



	Bands and Radiated Emission Limits)	radiated limits detailed in 15.209			
15.207	AC Conducted Emissions 150kHz - 30MHz	< FCC 15.207 limits	Line Conducted	Pass	Section 7.10



RSS-247, Issue 2 Section(s)	Test Description	Test Result	Reference
FCC 15.407(a)	26dB Bandwidth	Pass	Section 7.2
FCC 15.407(e) RSS-247 Issue 2 February 2017 Section 6.2.4.1	6dB Bandwidth	Pass	Section 7.3
FCC 15.407(h)(1) RSS-247 Issue 2 February 2017 Section 6.2.1.1& 6.2.2.1&6.2.3.1&6.2.4.1	Maximum Conducted Output Power	Pass	Section 7.4
FCC 15.407 (h)(1) RSS-247 Issue 2 February 2017 Section 6.2.1.1& 6.2.2.1&6.2.3.1&6.2.4.1	Transmit Power Control	Pass	Section 7.5
FCC 15.407(a)(1)(ii), (2), (3), (5) RSS-247 Issue 2 February 2017 Section 6.2.1.1& 6.2.2.1&6.2.3.1&6.2.4.1	Peak Power Spectral Density	Pass	Section 7.6
FCC 15.407(g) RSS-GEN Issue 4 Section 6.11	Frequency Stability	Pass	Section 7.7
15.407(b)(1), (2), (3), (4)	Undesirable Emissions	Pass	Section 7.8 & 7.9
FCC 15.205, 15.209 15.407(b)(5), (6), (7) RSS-247 Issue 2 February 2017 Section 6.2.1.2& 6.2.2.2&6.2.3.2&6.2.4.2	General Field Strength Limits (Restricted Bands and Radiated Emission Limits)	Pass	Section 7.8 & 7.9
FCC 15.207 RSS-Gen Issue 4 November 2014 Section 8.8	AC Conducted Emissions 150kHz - 30MHz	Pass	Section 7.10



2.2 General Information of Test

Test Site :	Cerpass Technology Corporation Test Laboratory Location: No.10 Lane2 Lianfu Street Luzhu District, Taoyuan City Taiwan ROC Tel:+886-3-3226-888 Fax:+886-3-3226-881
FCC Registration Number :	TW1439
IC Registration Number :	4934B-1
VCCI	T-2205 for Telecommunication Test C-4663 for Conducted emission test R-4399, R-4218 for Radiated emission test G-812, G-813 for radiated disturbance above 1GHz



2.3 Measuring Equipment

Instrument/Ancillary	Manufacturer	Model No.	Serial No.	Calibration Date	Valid Date.
Test Receiver	R&S	ESCI	100565	2017.03.26	2018.03.25
AMN	R&S	ESH2-Z5	100182	2016.09.06	2017.09.05
Two-Line V-Network	R&S	ENV216	100325	/	/
Pulse Limiter	R&S	ESH3-Z2	100529	2017.03.26	2018.03.25
Temperature/ Humidity Meter	Zhicheng	ZC1-11	CEP-TH-004	2017.03.29	2018.03.28
EZ-EMC	Fala	Ver CT3A1	N/A	N/A	N/A

Instrument/Ancillary	Manufacturer	Model No.	Serial No.	Calibration Date	Valid Date.
EMI Test Receiver	R&S	ESCI	101183	2017.03.26	2018.03.25
Preamplifier	songyi	EM330	60618	2017.03.26	2018.03.25
Preamplifier	Agilent	8449B	3008A02342	2017.03.26	2018.03.25
Bilog Antenna	Sunol Science	JB1	A072414-1	2017.04.16	2018.04.15
Broad-Band Horn Antenna	Schwarzbeck	BBHA9120D	9120D-618	2017.04.16	2018.04.15
Broad-Band Horn Antenna	Schwarzbeck	BBHA9170	9170-347	2017.04.16	2018.04.15
Preamplifier	COM-POWER	PA-840	711885	2017.03.26	2018.03.25
Spectrum Analyzer	R&S	FSP40	100324	2017.03.26	2018.03.25
Spectrum Analyzer	KEYSIGHT	N9010A	MY54200207	2017.03.17	2018.03.16
Temperature/ Humidity Meter	Zhicheng	ZC1-11	CEP-TH-002	2017.03.29	2018.03.28
EZ-EMC	Fala	Ver CT3A1	N/A	N/A	N/A



2.4 Measurement Uncertainty

ISO/IEC 17025 requires that an estimate of the measurement uncertainties associated with the emissions test results be included in the report. The measurement uncertainties given below are based on a 95% confidence level (based on a coverage factor (k=2)).

Measurement Item	Measurement Frequency	Polarization	Uncertainty
Conducted Emission	9 kHz ~ 30 MHz	Line / Neutral	± 2.9076 dB
Radiated Emission	9 kHz ~ 40,000 MHz	Vertical / Horizontal	± 0.948 dB
Spurious Emission (Conducted)	-	-	± 4.011 dB
Maximum Peak and Average Output Power	-	-	± 0.322 dB
Power Spectral Density	-	-	± 0.322 dB
Bandwidth	-	-	74.224Hz



3. Test of Conducted Emission

3.1 Test Limit

Conducted Emissions were measured from 150 kHz to 30 MHz with a bandwidth of 9 KHz on the 120 VAC power and return leads of the EUT according to the methods defined in ANSI C63.10-2013 Section 6.2. The EUT was placed on a nonmetallic stand in a shielded room 0.8 meters above the ground plane as shown in section 6.2.2. The interface cables and equipment positioning were varied within limits of reasonable applications to determine the position produced maximum conducted emissions.

Frequency (MHz)	Quasi Peak (dB μ V)	AVG (dB μ V)
0.15 – 0.5	66-56*	56-46*
0.5 – 5.0	56	46
5.0 – 30.0	60	50

*Decreases with the logarithm of the frequency.

3.2 Test Standard

ANSI C63.10: 2013 Section 6.2.

3.3 Test Procedures

The EUT was placed on a platform of nominal size, 1 m by 1.5 m, raised 80 cm above the conducting ground plane. The vertical conducting plane was located 40 cm to the rear of the EUT. All other surfaces of EUT were at least 80 cm from any other grounded conducting surface. The EUT and simulators are connected to the main power through a line impedance stabilization network (LISN). The LISN provides a 50 ohm /50uH coupling impedance for the measuring equipment. The peripheral devices are also connected to the main power through a LISN. (Please refer to the block diagram of the test setup and photographs) Each current-carrying conductor of the EUT power cord, except the ground (safety) conductor, was individually connected through a LISN to the input power source.

The excess length of the power cord between the EUT and the LISN receptacle were folded back and forth at the center of the lead to form a bundle not exceeding 40 cm in length.

Conducted emissions were investigated over the frequency range from 0.15MHz to 30MHz using a receiver bandwidth of 9 kHz.



3.4 Test Setup

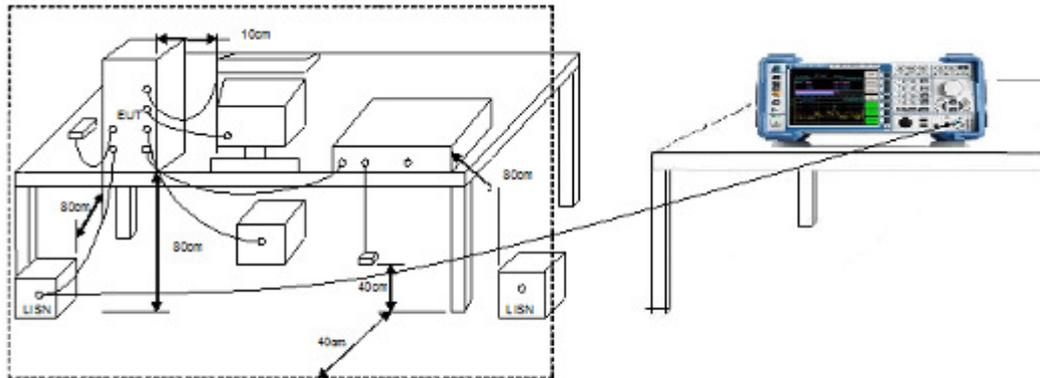



3.5 Test Result and Data

Test Mode :	Mode 1: Normal Operation with wifi on		
AC Power :	AC 120V/60Hz	Phase :	LINE
Temperature :	26°C	Humidity :	60%
Pressure(mbar) :	1002	Date:	2017/07/27

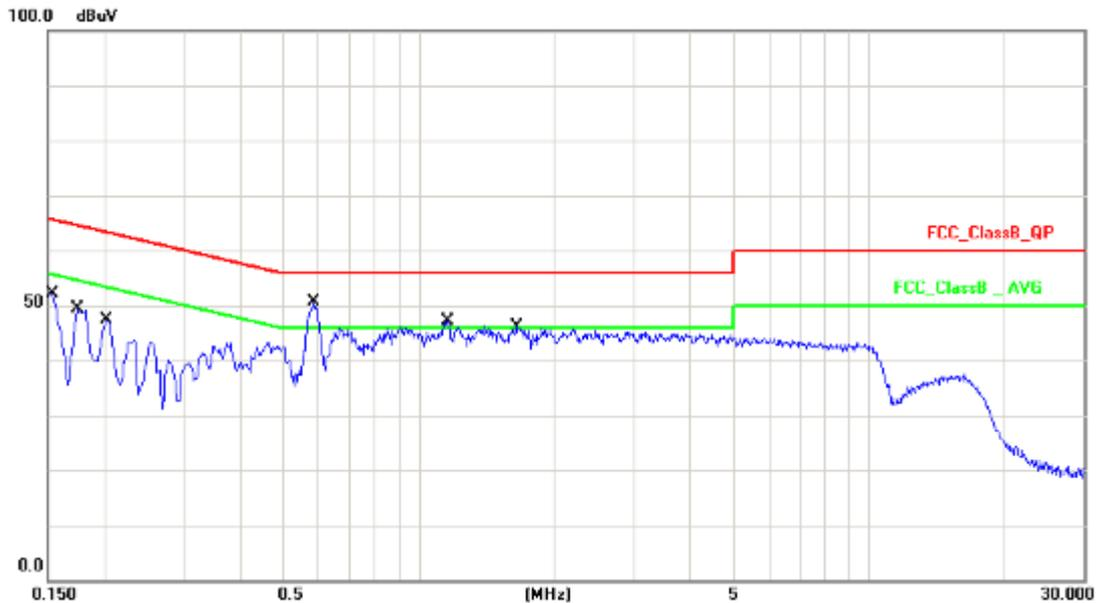

No.	Frequency (MHz)	Factor (dB)	Reading (dBuV)	Level (dBuV)	Limit (dBuV)	Margin (dB)	Detector
1	0.1540	10.13	38.01	48.14	65.78	-17.64	QP
2	0.1540	10.13	23.31	33.44	55.78	-22.34	AVG
3	0.1740	10.13	34.50	44.63	64.77	-20.14	QP
4	0.1740	10.13	20.23	30.36	54.77	-24.41	AVG
5	0.2020	10.12	33.07	43.19	63.53	-20.34	QP
6	0.2020	10.12	21.95	32.07	53.53	-21.46	AVG
7	0.5860	10.16	36.68	46.84	56.00	-9.16	QP
8	0.5860	10.16	28.49	38.65	46.00	-7.35	AVG
9	1.1620	10.16	33.28	43.44	56.00	-12.56	QP
10	1.1620	10.16	22.65	32.81	46.00	-13.19	AVG
11	1.6500	10.17	31.92	42.09	56.00	-13.91	QP
12	1.6500	10.17	21.96	32.13	46.00	-13.87	AVG

Note: Measurement Level = Reading Level + Correct Factor



Test Mode :	Mode 1: Normal Operation with wifi on		
AC Power :	AC 120V/60Hz	Phase :	NEUTRAL
Temperature :	26°C	Humidity :	60%
Pressure(mbar) :	1002	Date:	2017/07/27

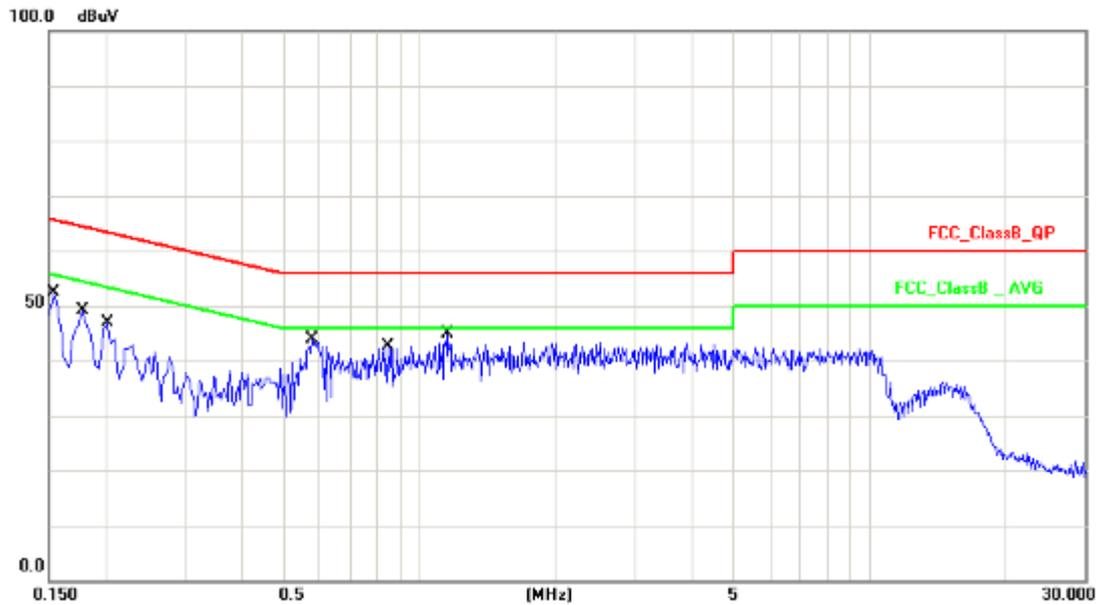

No.	Frequency (MHz)	Factor (dB)	Reading (dBuV)	Level (dBuV)	Limit (dBuV)	Margin (dB)	Detector
1	0.1540	10.13	37.96	48.09	65.78	-17.69	QP
2	0.1540	10.13	20.07	30.20	55.78	-25.58	AVG
3	0.1780	10.13	35.73	45.86	64.58	-18.72	QP
4	0.1780	10.13	18.73	28.86	54.58	-25.72	AVG
5	0.2020	10.13	32.38	42.51	63.53	-21.02	QP
6	0.2020	10.13	15.86	25.99	53.53	-27.54	AVG
7	0.5780	10.15	30.66	40.81	56.00	-15.19	QP
8	0.5780	10.15	22.77	32.92	46.00	-13.08	AVG
9	0.8500	10.17	24.63	34.80	56.00	-21.20	QP
10	0.8500	10.17	15.52	25.69	46.00	-20.31	AVG
11	1.1500	10.18	26.76	36.94	56.00	-19.06	QP
12	1.1500	10.18	15.44	25.62	46.00	-20.38	AVG

Note: Measurement Level = Reading Level + Correct Factor



4. Test of Radiated Emission

4.1 Test Limit

According to §15.209(a), except as provided elsewhere in this Subpart, the emissions from an intentional radiator shall not exceed the field strength levels specified in the following table:

FCC Part 15 Subpart C Paragraph 15.209		
FREQUENCIES (MHz)	FIELD STRENGTH (micro volts/meter)	MEASUREMENT DISTANCE (meters)
0.009~0.490	2400/F(kHz)	300
0.490~1.705	24000/F(kHz)	30
1.705~30.0	30	30
30~88	100	3
88~216	150	3
216~960	200	3
Above 960	500	3

Note 1: The lower limit shall apply at the transition frequency.

Note 2: Distance refers to the distance in meters between the measuring instrument Antenna and the closed point of any part of the device or system.

Note 3: E field strength (dBuV/m) = 20 log E field strength (uV/m)

Note 4: **Except as provided in paragraph (g), fundamental emissions from intentional radiators operating under this section shall not be located in the frequency bands 54-72 MHz, 76-88 MHz, 174-216 MHz or 470-806 MHz. However, operation within these frequency bands is permitted under other sections of this part, e.g., §§15.231 and 15.241.

4.2 Test Standard

KDB 789033 D02v01r04 – Section G



4.3 Test Procedures

Quasi-Peak Field Strength Measurements:

1. Analyzer center frequency was set to the frequency of the radiated spurious emission of interest
2. Span was set greater than 1MHz
3. RBW = 120 kHz
4. Detector = CISPR quasi-peak
5. Sweep time = auto couple
6. Trace was allowed to stabilize

Peak Field Strength Measurements:

1. Analyzer center frequency was set to the frequency of the radiated spurious emission of interest
2. RBW = 1MHz
3. VBW = 3MHz
4. Detector = peak
5. Sweep time = auto couple
6. Trace mode = max hold
7. Trace was allowed to stabilize

AVE Field Strength Measurements:

1. Analyzer center frequency was set to the frequency of the radiated spurious emission of interest
2. RBW = 1MHz
3. VBW = 3MHz
4. Detector = power average (Average)
5. Number of measurement points = 1001 (Number of points must be $> 2 \times \text{span}/\text{RBW}$)
6. Sweep time = auto
7. Trace was averaged over at 100 sweeps



4.4 Test Setup

9kHz~30MHz Test Setup

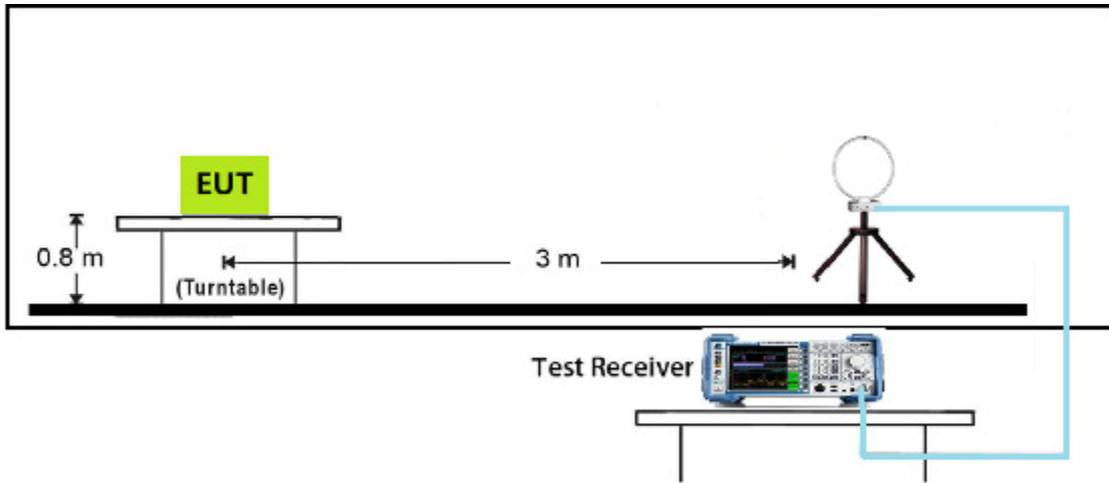



Below 1GHz Test Setup

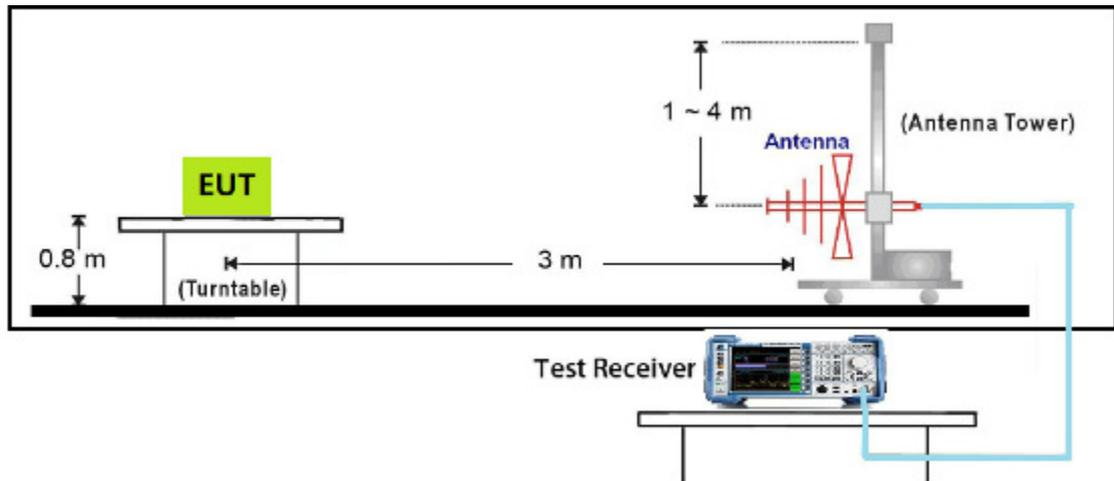

1GHz~18GHz Test Setup

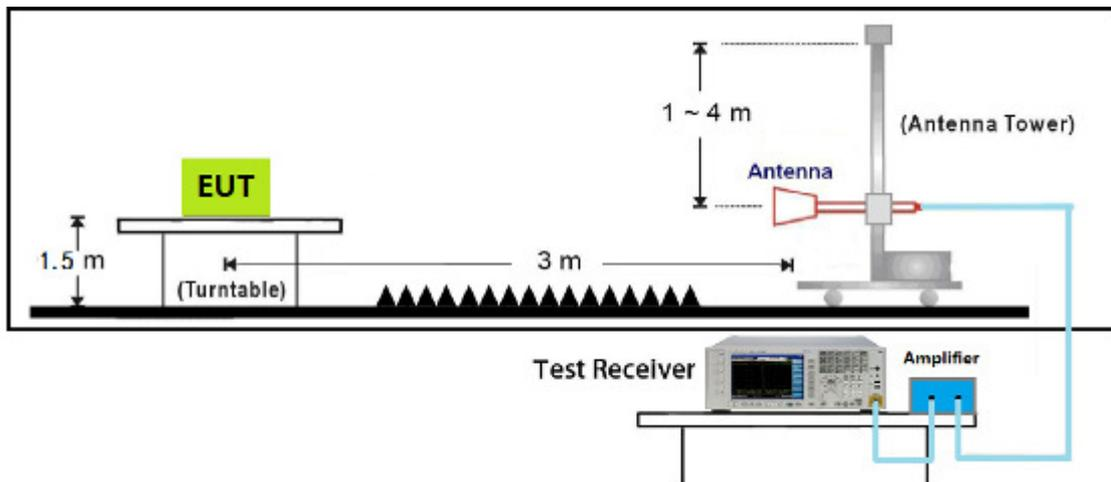

18GHz~40GHz Test Setup

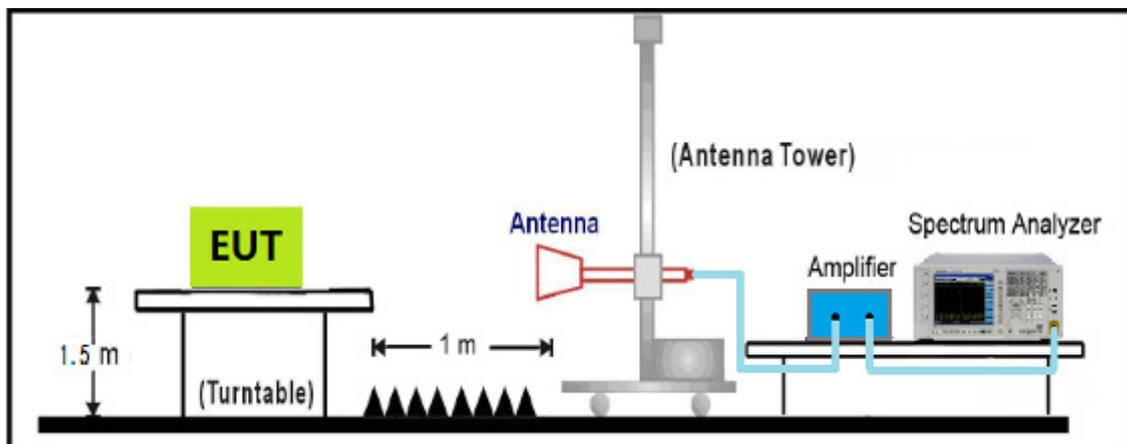



4.5 Test Result and Data

The worst case of Radiated Emission below 1GHz:

Limit: FCC_Part15.209_RE(3m)	Margin: 0
Probe: N/A	Polarity: Horizontal
EUT:IP CAMERA	Power: AC 120V/60Hz
Note: Mode1: Transmit at channel 5220MHz by 802.11a	

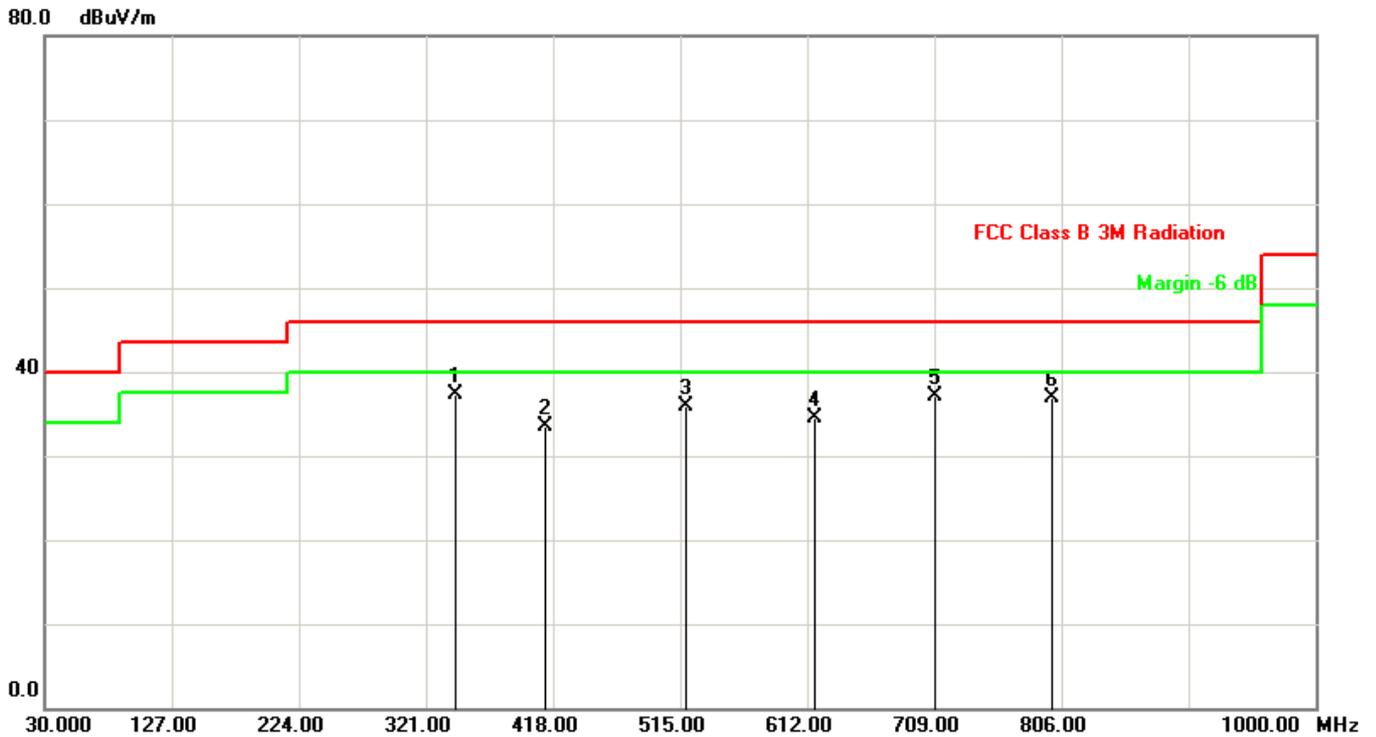

No.	Frequency (MHz)	Factor (dB/m)	Reading (dBuV)	Level (dBuV/m)	Limit (dBuV/m)	Margin (dB)	Det.
1	344.2799	-6.64	43.99	37.35	46.00	-8.65	QP
2	412.1800	-4.24	37.69	33.45	46.00	-12.55	QP
3	519.8500	-4.44	40.28	35.84	46.00	-10.16	QP
4	617.8200	-1.39	35.92	34.53	46.00	-11.47	QP
5	709.0000	1.24	35.85	37.09	46.00	-8.91	QP
6	799.2100	0.79	36.16	36.95	46.00	-9.05	QP

Note: Measure Level (dBuV/m) = Reading Level (dBuV) + Factor(dB).

Factor (dB)=Cable Loss(dB) + Antenna Factor (dB/m) - Pre_Amplifier Gain(dB)



Limit: FCC_Part15.209_RE(3m)	Margin: 0
Probe: N/A	Polarity: Vertical
EUT:IP CAMERA	Power: AC 120V/60Hz
Note: Mode1: Transmit at channel 5220MHz by 802.11a	

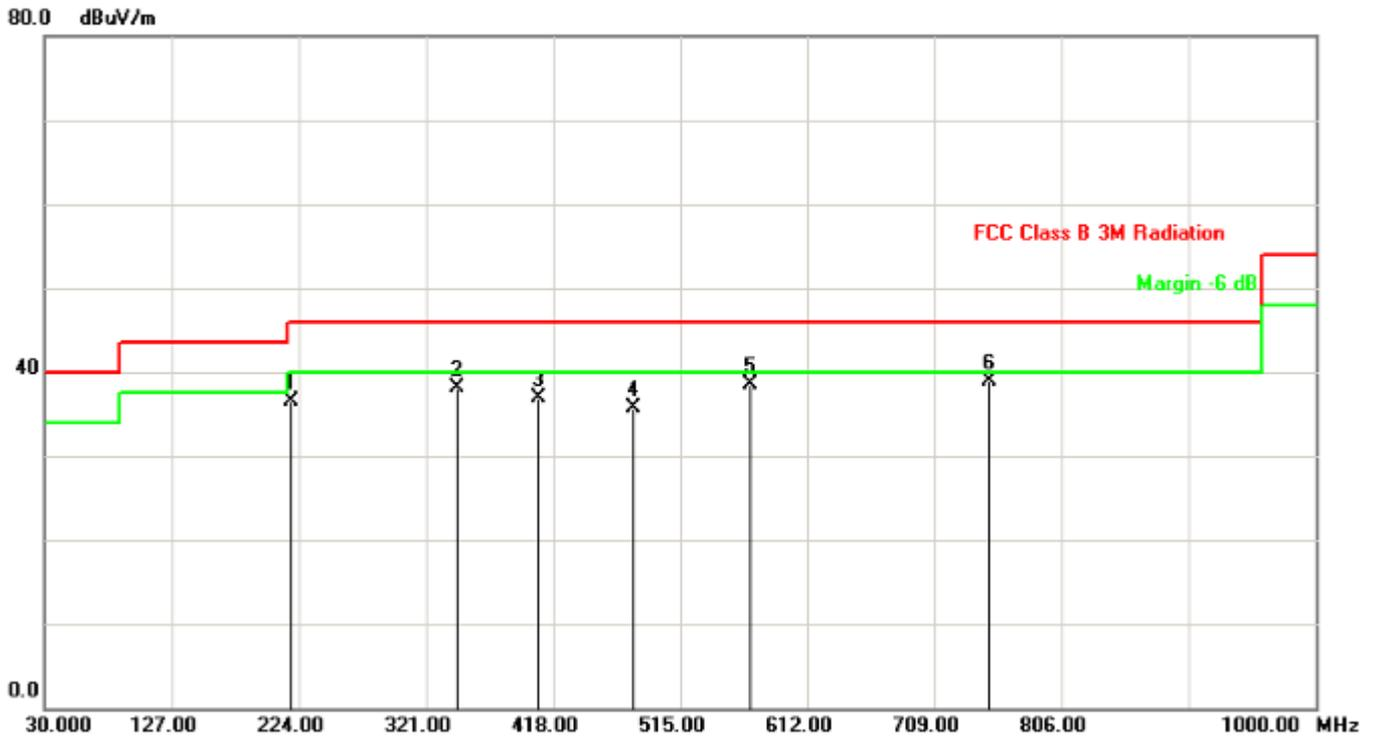

No.	Frequency (MHz)	Factor (dB/m)	Reading (dBuV)	Level (dBuV/m)	Limit (dBuV/m)	Margin (dB)	Det.
1	218.1800	-12.21	48.73	36.52	46.00	-9.48	QP
2	345.2500	-6.65	44.84	38.19	46.00	-7.81	QP
3	407.3299	-4.84	41.76	36.92	46.00	-9.08	QP
4	479.1100	-6.25	42.05	35.80	46.00	-10.20	QP
5	568.3500	-3.01	41.50	38.49	46.00	-7.51	QP
6	750.7100	1.37	37.60	38.97	46.00	-7.03	QP

Note: Measure Level (dBuV/m) = Reading Level (dBuV) + Factor(dB).

Factor (dB)=Cable Loss(dB) + Antenna Factor (dB/m) - Pre_Amplifier Gain(dB)

**Radiated Emission above 1GHz:**

Mode1: Transmit by 802.11a

CH	Antenna	Frequency (MHz)	Reading Level (dBuV/m)	Factor (dB)	Measure Level (dBuV/m)	Limit (dBuV/m)	Margin (dB)	Detector
36	H	10360	36.5	11.63	48.1	54(note3)	-5.9	PK
	H	15540	32.1	19.72	51.8	54(note3)	-2.2	PK
	V	10360	36.9	11.63	48.5	54(note3)	-5.5	PK
	V	15540	29.7	19.72	49.4	54(note3)	-4.6	PK
44	H	10440	37	11.85	48.9	54(note3)	-5.2	PK
	H	15660	32.8	19.79	52.6	54(note3)	-1.4	PK
	V	10440	37.4	11.85	49.3	54(note3)	-4.8	PK
	V	15660	30.2	19.79	50.0	54(note3)	-4.0	PK
48	H	10480	36.8	11.75	48.6	54(note3)	-5.5	PK
	H	15720	32.4	19.82	52.2	54(note3)	-1.8	PK
	V	10480	36.5	11.75	48.3	54(note3)	-5.8	PK
	V	15720	29.7	19.82	49.5	54(note3)	-4.5	PK
149	H	11490	32.6	10.13	42.7	54(note3)	-11.3	PK
	H	17235	28.6	17.63	46.2	54(note3)	-7.8	PK
	V	11490	31.7	10.13	41.8	54(note3)	-12.2	PK
	V	17235	28.6	17.63	46.2	54(note3)	-7.8	PK
157	H	11570	32.5	9.92	42.4	54(note3)	-11.6	PK
	H	17355	29.7	15.26	45.0	54(note3)	-9.0	PK
	V	11570	32.5	9.92	42.4	54(note3)	-11.6	PK
	V	17355	28.4	15.26	43.7	54(note3)	-10.3	PK
165	H	11650	31.9	9.52	41.4	54(note3)	-12.6	PK
	H	17475	30.9	17.19	48.1	54(note3)	-5.9	PK
	V	11650	32.3	9.52	41.8	54(note3)	-12.2	PK
	V	17475	28.4	17.19	45.6	54(note3)	-8.4	PK

Note: 1. Measure Level = Reading Level + Factor.

2. The test trace is same as the ambient noise (the test frequency range: 9kHz~30MHz, 18GHz~25GHz), therefore no data appear in the report.

3. This limit applies for using average detector, if the test result on peak is lower than average limit, then average measurement needn't be performed.

Mode1: Transmit by 802.11n(20MHz)



CH	Antenna	Frequency (MHz)	Reading Level (dBuV/m)	Factor (dB)	Measure Level (dBuV/m)	Limit (dBuV/m)	Margin (dB)	Detector
36	H	10360	33.7	11.63	45.3	54(note3)	-8.7	PK
	H	15540	32.5	19.72	52.2	54(note3)	-1.8	PK
	V	10360	34.9	11.63	46.5	54(note3)	-7.5	PK
	V	15540	28.9	19.72	48.6	54(note3)	-5.4	PK
44	H	10440	33.5	11.85	45.4	54(note3)	-8.7	PK
	H	15660	31.6	19.79	51.4	54(note3)	-2.6	PK
	V	10440	35.4	11.85	47.3	54(note3)	-6.8	PK
	V	15660	28.3	19.79	48.1	54(note3)	-5.9	PK
48	H	10480	33.1	11.75	44.9	54(note3)	-9.2	PK
	H	15720	30.9	19.82	50.7	54(note3)	-3.3	PK
	V	10480	32.1	11.75	43.9	54(note3)	-10.2	PK
	V	15720	29.5	19.82	49.3	54(note3)	-4.7	PK
149	H	11490	30.6	10.13	40.7	54(note3)	-13.3	PK
	H	17235	28.1	17.63	45.7	54(note3)	-8.3	PK
	V	11490	29.4	10.13	39.5	54(note3)	-14.5	PK
	V	17235	27.3	17.63	44.9	54(note3)	-9.1	PK
157	H	11570	30.5	9.92	40.4	54(note3)	-13.6	PK
	H	17355	28.4	15.26	43.7	54(note3)	-10.3	PK
	V	11570	29.6	9.92	39.5	54(note3)	-14.5	PK
	V	17355	28.7	15.26	44.0	54(note3)	-10.0	PK
165	H	11650	30.5	9.52	40.0	54(note3)	-14.0	PK
	H	17475	28.3	17.19	45.5	54(note3)	-8.5	PK
	V	11650	27.9	9.52	37.4	54(note3)	-16.6	PK
	V	17475	28.2	17.19	45.4	54(note3)	-8.6	PK

Note: 1. Measure Level = Reading Level + Factor.

2. The test trace is same as the ambient noise (the test frequency range: 9kHz~30MHz, 18GHz~25GHz), therefore no data appear in the report.

3. This limit applies for using average detector, if the test result on peak is lower than average limit, then average measurement needn't be performed.



Mode3: Transmit by 802.11n(40MHz)

CH	Antenna	Frequency (MHz)	Reading Level (dBuV/m)	Factor (dB)	Measure Level (dBuV/m)	Limit (dBuV/m)	Margin (dB)	Detector
38	H	10380	28.6	11.63	40.2	54(note3)	-13.8	PK
	H	15570	25.7	19.28	45.0	54(note3)	-9.0	PK
	V	10380	27.3	11.63	38.9	54(note3)	-15.1	PK
	V	15570	27.1	19.28	46.4	54(note3)	-7.6	PK
46	H	10460	29.5	11.63	41.1	54(note3)	-12.9	PK
	H	15690	24.9	19.41	44.3	54(note3)	-9.7	PK
	V	10460	28.5	11.63	40.1	54(note3)	-13.9	PK
	V	15690	27.2	19.41	46.6	54(note3)	-7.4	PK
151	H	11510	31.5	17.52	49.0	54(note3)	-5.0	PK
	H	17265	29.2	10.11	39.3	54(note3)	-14.7	PK
	V	11510	28.6	17.52	46.1	54(note3)	-7.9	PK
	V	17265	28.7	10.11	38.8	54(note3)	-15.2	PK
159	H	11590	30.5	9.83	40.3	54(note3)	-13.7	PK
	H	17385	29.7	15.09	44.8	54(note3)	-9.2	PK
	V	11590	28.7	9.83	38.5	54(note3)	-15.5	PK
	V	17385	28.3	15.09	43.4	54(note3)	-10.6	PK

Note: 1. Measure Level = Reading Level + Factor.

2. The test trace is same as the ambient noise (the test frequency range: 9kHz~30MHz, 18GHz~25GHz), therefore no data appear in the report.

3. This limit applies for using average detector, if the test result on peak is lower than average limit, then average measurement needn't be performed.



Mode4: Transmit by 802.11ac(80)

CH	Antenna	Frequency (MHz)	Reading Level (dBuV/m)	Factor (dB)	Measure Level (dBuV/m)	Limit (dBuV/m)	Margin (dB)	Detector
42	H	10420	28.3	11.57	39.9	54(note3)	-14.1	PK
	H	15630	26.9	19.38	46.3	54(note3)	-7.7	PK
	V	10420	29.4	11.57	41.0	54(note3)	-13.0	PK
	V	15630	27.3	19.38	46.7	54(note3)	-7.3	PK
155	H	11550	29.4	9.84	39.2	54(note3)	-14.8	PK
	H	17325	28.3	15.12	43.4	54(note3)	-10.6	PK
	V	11550	27.8	9.84	37.6	54(note3)	-16.4	PK
	V	17325	26.7	15.12	41.8	54(note3)	-12.2	PK

Note: 1. Measure Level = Reading Level + Factor.

2. The test trace is same as the ambient noise (the test frequency range: 9kHz~30MHz, 18GHz~25GHz), therefore no data appear in the report.

3. This limit applies for using average detector, if the test result on peak is lower than average limit, then average measurement needn't be performed.



The worst case of Radiated Emission 1~18GHz:

Site:AC102	Time: 2017/07/27
Limit: FCC_Part15.209_RE(3m)	Margin: 0
Probe: N/A	Polarity: Horizontal
EUT:IP CAMERA	Power: AC 120V/60Hz
Note: Mode: Transmit 802.11a at 5220MHz	

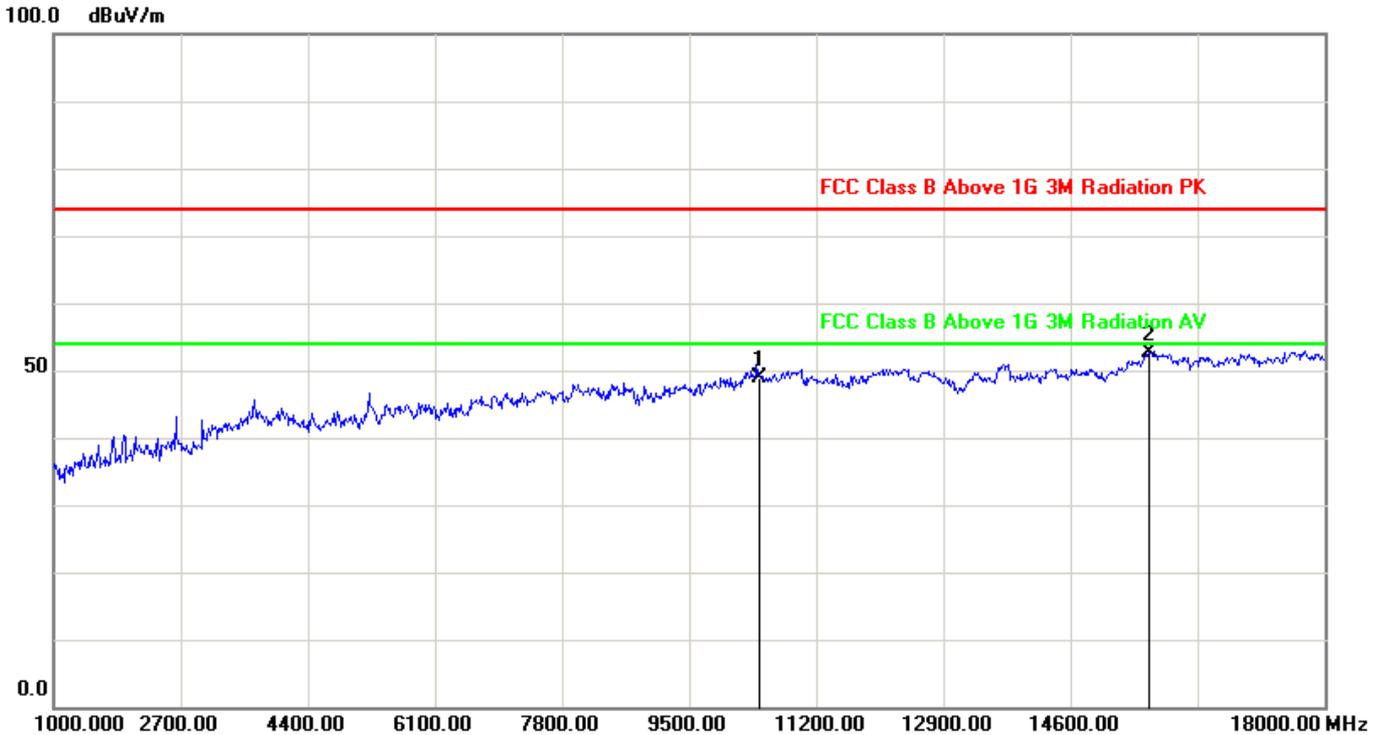

No.	Frequency (MHz)	Factor (dB/m)	Reading (dBuV)	Level (dBuV/m)	Limit (dBuV/m)	Margin (dB)	Det.
1	10440.000	11.85	37.0	48.9	54(note3)	-5.2	peak
2	15660.000	19.79	32.8	52.6	54(note3)	-1.4	peak

Note:

1. All Readings below 1GHz are Quasi-Peak, above are performed with peak and/or AVG measurements as necessary.
2. Measurement Level = Reading Level + Correct Factor
3. The test trace is same as the ambient noise (the test frequency range: 9kHz~30MHz, 18GHz~40GHz), therefore no data appear in the report.



Site:AC102	Time: 2017/07/27
Limit: FCC_Part15.209_RE(3m)	Margin: 0
Probe: N/A	Polarity: Vertical
EUT:IP CAMERA	Power: AC 120V/60Hz
Note: Mode: Transmit 802.11a at 5220MHz	

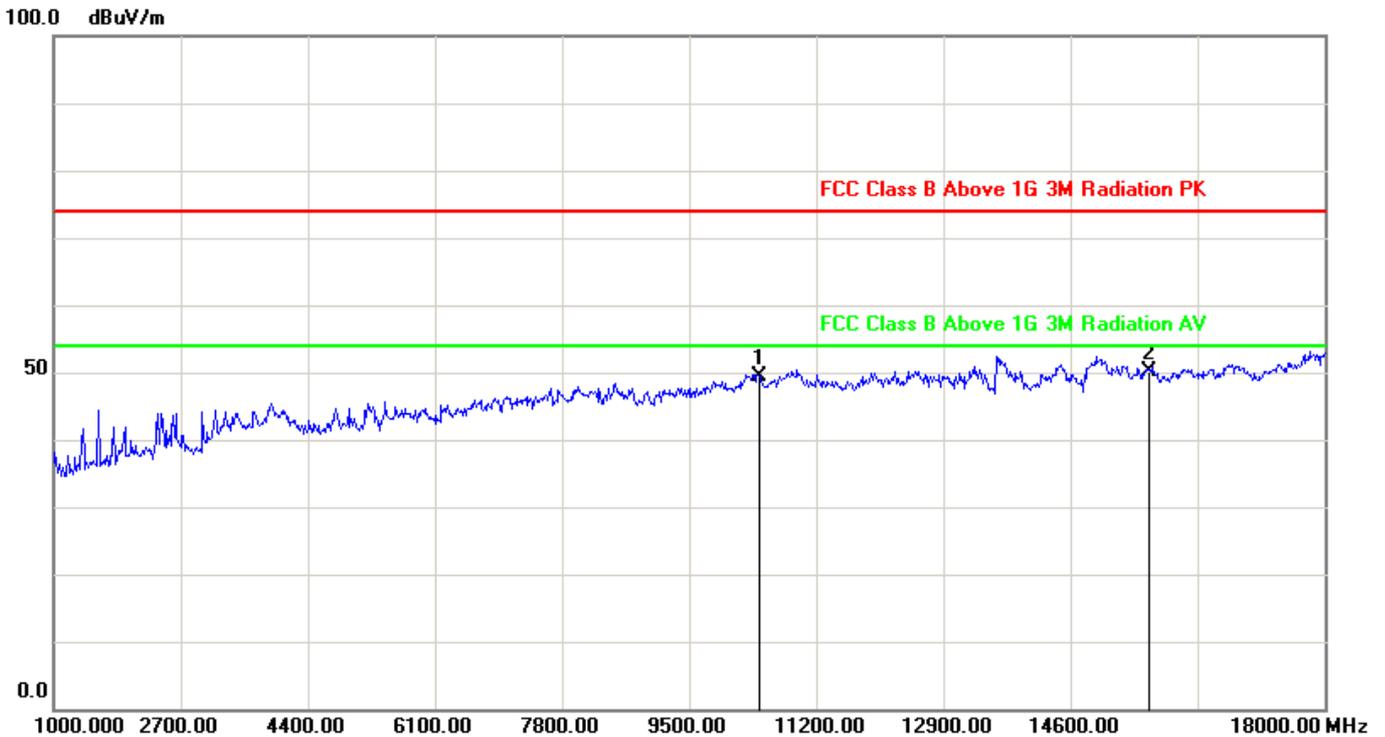

No.	Frequency (MHz)	Factor (dB/m)	Reading (dBuV)	Level (dBuV/m)	Limit (dBuV/m)	Margin (dB)	Det.
1	10440.000	11.85	37.4	49.3	54(note3)	-4.8	peak
2	15660.000	19.79	30.2	50.0	54(note3)	-4.0	peak

Note:

1. All Readings below 1GHz are Quasi-Peak, above are performed with peak and/or AVG measurements as necessary.
2. Measurement Level = Reading Level + Correct Factor
3. The test trace is same as the ambient noise (the test frequency range: 9kHz~30MHz, 18GHz~40GHz), therefore no data appear in the report.



5. 26dB Occupied Bandwidth

5.1 Test Limit

N/A

5.2 Test Standard

KDB 789033 D02v01r04– Section C.1



5.3 Test Procedures

The EUT was tested according to KDB 789033 for compliance to FCC 47CFR 15.407 requirements.

Emission Bandwidth

- Use a RBW = approximately 1% of the emission bandwidth.
- Set the VBW > RBW
- Detector = Peak.
- Trace mode = max hold.
- Measure the maximum width of the emission that is 26 dB down from the peak of the emission.

Compare this with the RBW setting of the analyzer. Readjust RBW and repeat measurement as needed until the RBW/EBW ratio is approximately 1%.

99% Occupied Bandwidth

- Set center frequency to the nominal EUT channel center frequency.
- Set span = 1.5 times to 5.0 times the OBW.
- Set RBW = 1 % to 5 % of the OBW.
- Set VBW $\geq 3 \cdot$ RBW.
- Video averaging is not permitted. Where practical, a sample detection and single sweep mode shall be used. Otherwise, peak detection and max hold mode (until the trace stabilizes) shall be used.
- Use the 99 % power bandwidth function of the instrument (if available).
- If the instrument does not have a 99 % power bandwidth function, the trace data points are recovered and directly summed in power units. The recovered amplitude data points, beginning at the lowest frequency, are placed in a running sum until 0.5 % of the total is reached; that frequency is recorded as the lower frequency. The process is repeated until 99.5 % of the total is reached; that frequency is recorded as the upper frequency. The 99% occupied bandwidth is the difference between these two frequencies.



5.4 Test Setup

Spectrum Analyzer

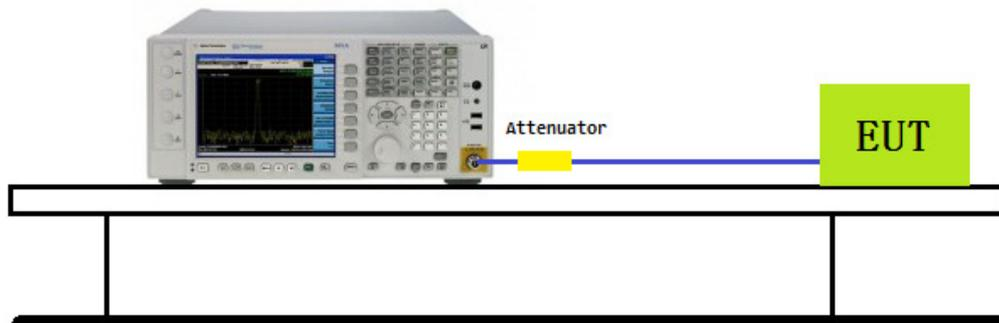



5.5 Test Result and Data

Test Item	Occupied Bandwidth
Test Mode	Transmit by 802.11a
Test Date	2017-07-27

Channel No.	Frequency (MHz)	26dB Bandwidth (MHz)	99% Occupied Bandwidth (MHz)	Result
36	5180	21.92	16.759	Pass
44	5220	23.61	16.779	Pass
48	5240	23.62	16.784	Pass
149	5745	21.35	16.728	Pass
157	5785	22.97	16.731	Pass
165	5825	23.00	16.746	Pass



Channel 36 (5180MHz)

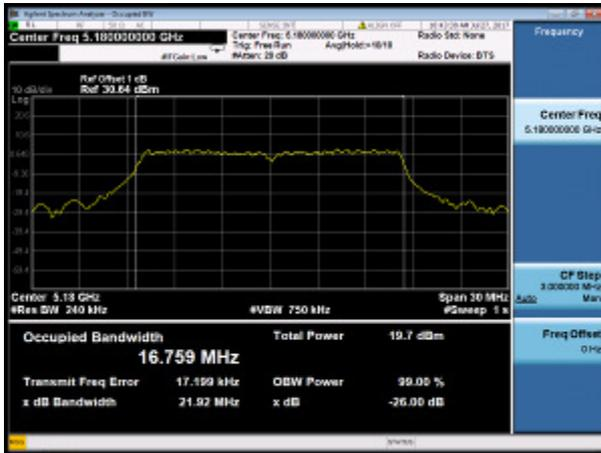

Channel 44 (5220MHz)

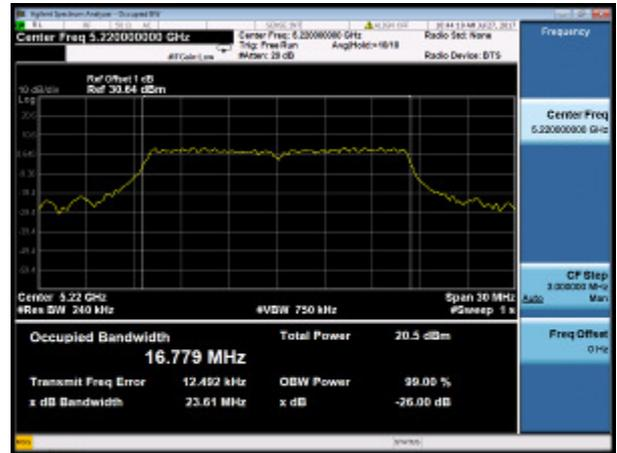

Channel 48 (5240MHz)

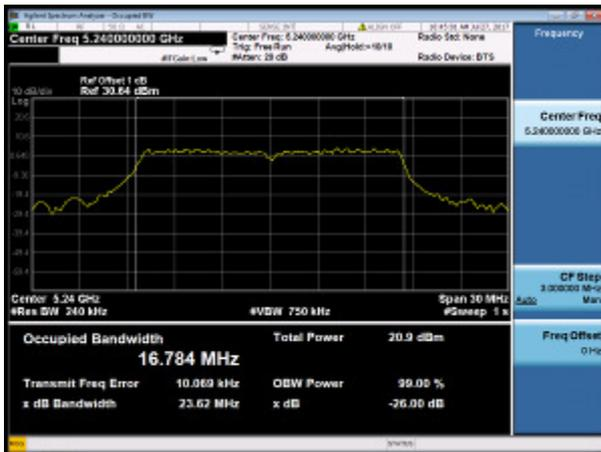

Channel 149 (5745MHz)

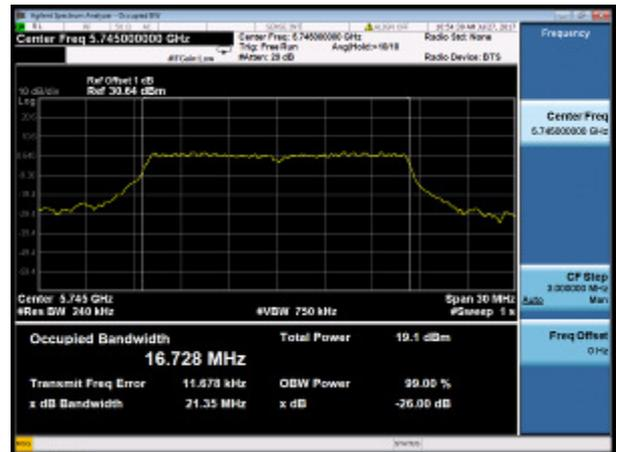

Channel 157 (5785MHz)

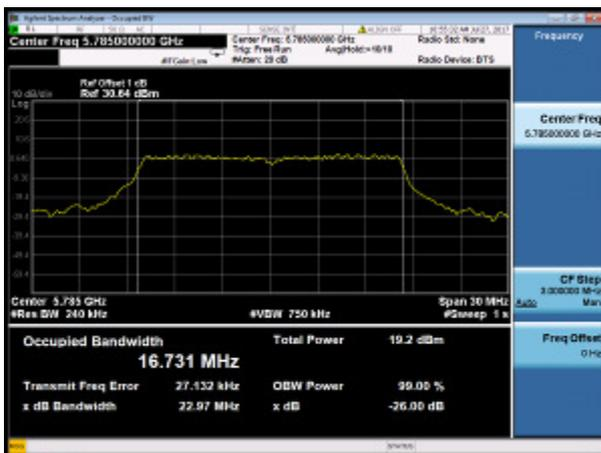

Channel 165 (5825MHz)

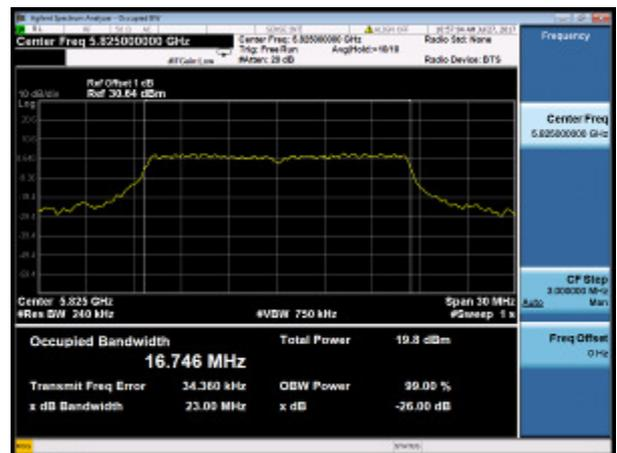



Test Item	Occupied Bandwidth
Test Mode	Transmit by 802.11n(20MHz)
Test Date	2017-07-27

Channel No.	Frequency (MHz)	26dB Bandwidth (MHz)	99% Occupied Bandwidth (MHz)	Result
36	5180	21.80	17.824	Pass
44	5220	21.88	17.831	Pass
48	5240	21.96	17.845	Pass
149	5745	22.29	17.828	Pass
157	5785	22.37	17.842	Pass
165	5825	22.37	17.850	Pass



Channel 36 (5180MHz)

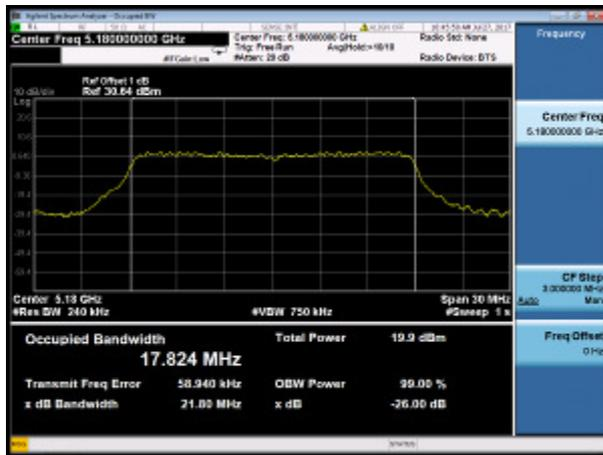

Channel 44 (5220MHz)

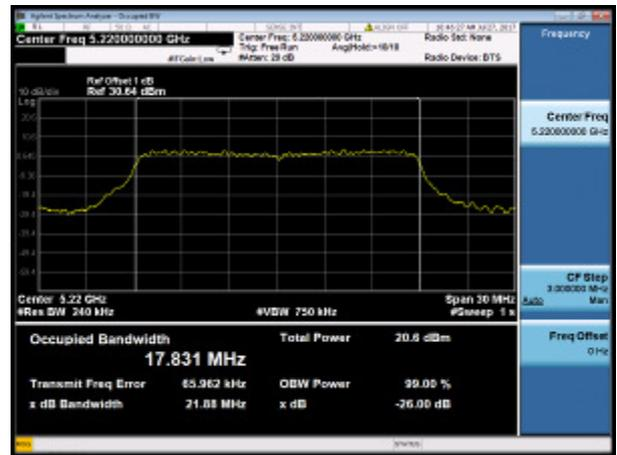

Channel 48 (5240MHz)

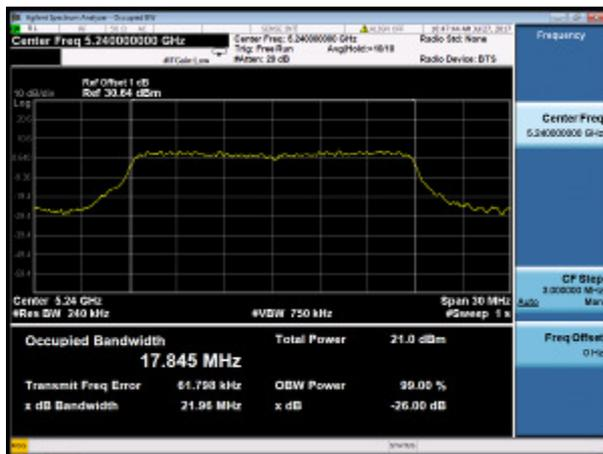

Channel 149 (5745MHz)

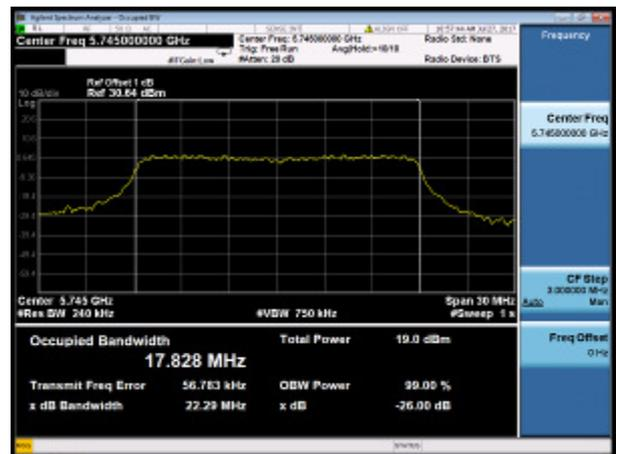

Channel 157 (5785MHz)

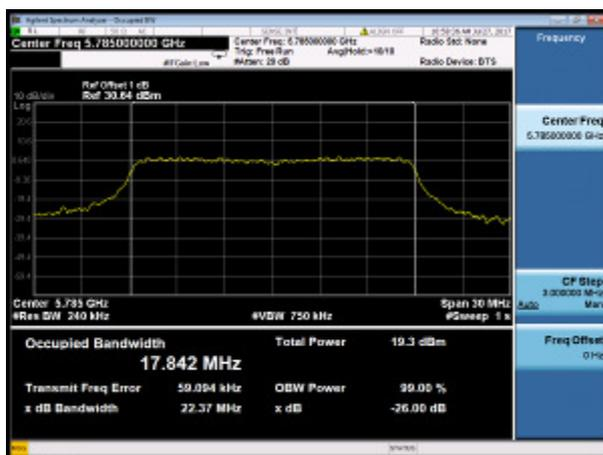

Channel 165 (5825MHz)

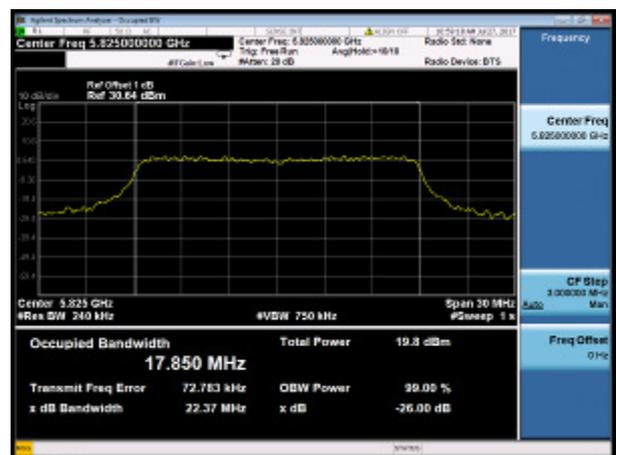



Test Item	Occupied Bandwidth
Test Mode	Transmit by 802.11n(40MHz)
Test Date	2017-07-27

Channel No.	Frequency (MHz)	26dB Bandwidth (MHz)	99% Occupied Bandwidth (MHz)	Result
38	5190	43.92	36.609	Pass
46	5230	43.88	36.651	Pass
151	5755	50.42	36.661	Pass
159	5795	50.50	36.662	Pass

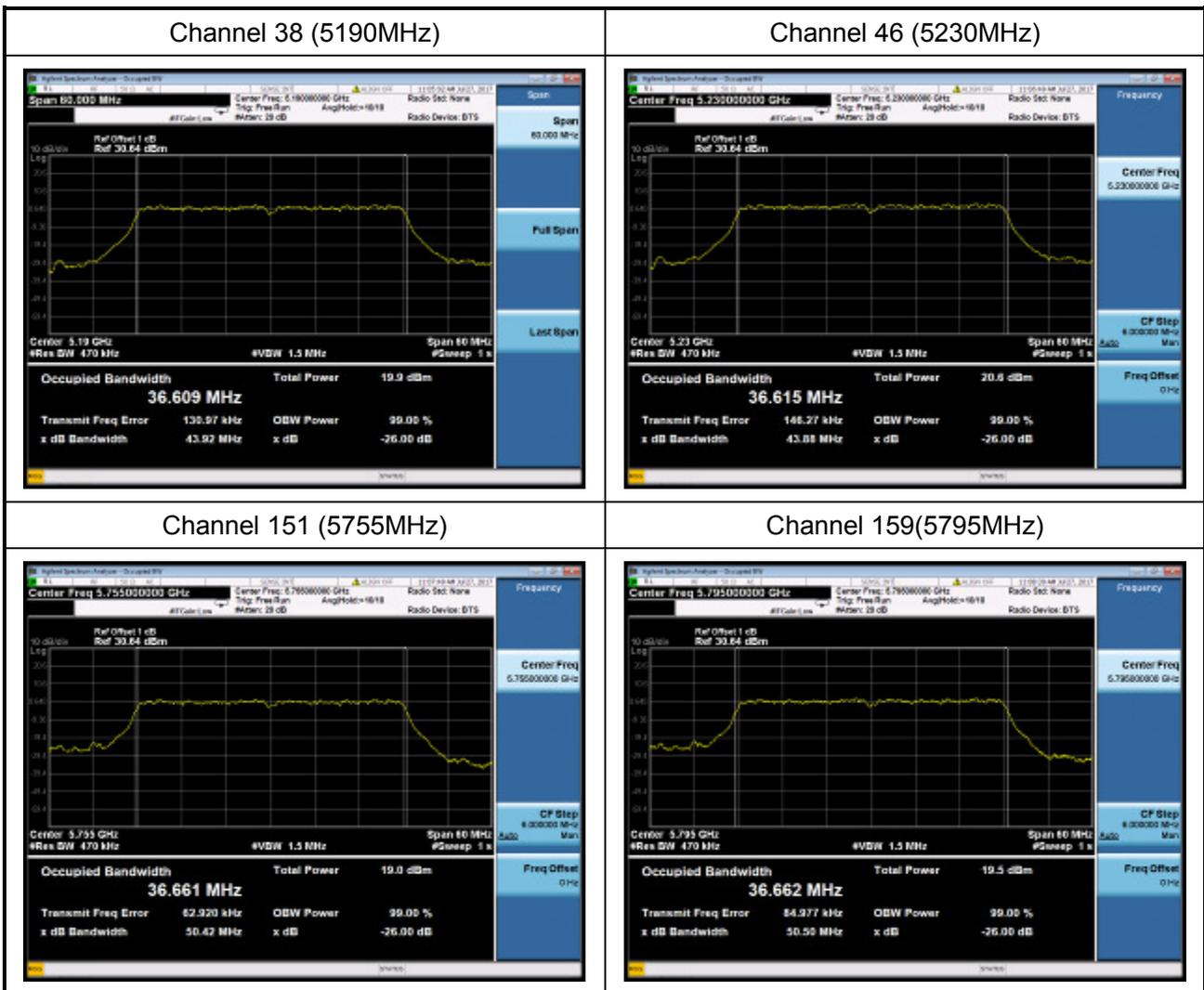



Test Item	Occupied Bandwidth
Test Mode	Transmit by 802.11ac(80MHz)
Test Date	2017-07-27

Channel No.	Frequency (MHz)	26dB Bandwidth (MHz)	99% Occupied Bandwidth (MHz)	Result
42	5210	82.95	75.093	Pass
155	5775	95.36	75.200	Pass

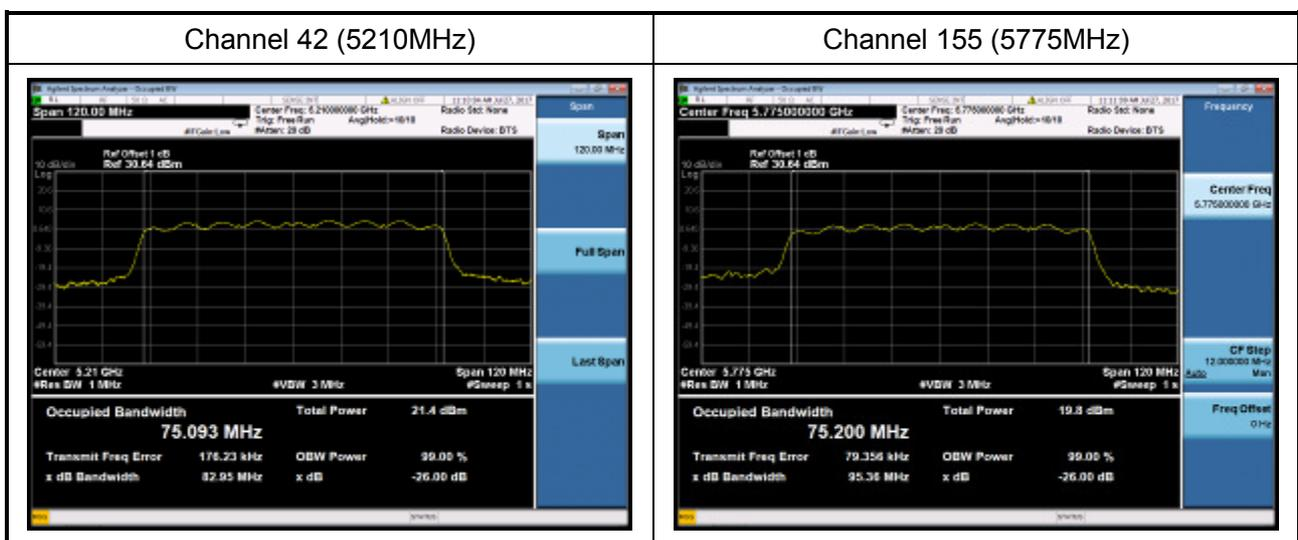



6. 6dB Bandwidth Measurement

6.1 Test Limit

Section 15.407(e) specifies the minimum 6 dB emission bandwidth of at least 500 kHz for the band 5.725-5.85 GHz.

6.2 Test Standard

KDB 789033 D02v01r04 – Section C.2

6.3 Test Procedures

1. Set center frequency to the nominal EUT channel center frequency.
2. RBW = 100 kHz.
3. VBW $\cong 3 \times$ RBW.
4. Detector = Peak.
5. Trace mode = max hold.
6. Sweep = auto couple.
7. Allow the trace to stabilize.
8. Measure the maximum width of the emission that is constrained by the frequencies associated with the two outermost amplitude points (upper and lower frequencies) that are attenuated by 6 dB relative to the maximum level measured in the fundamental emission.

Note: The automatic bandwidth measurement capability of a spectrum analyzer or EMI receiver may be employed if it implements the functionality described above.

6.4 Test Setup

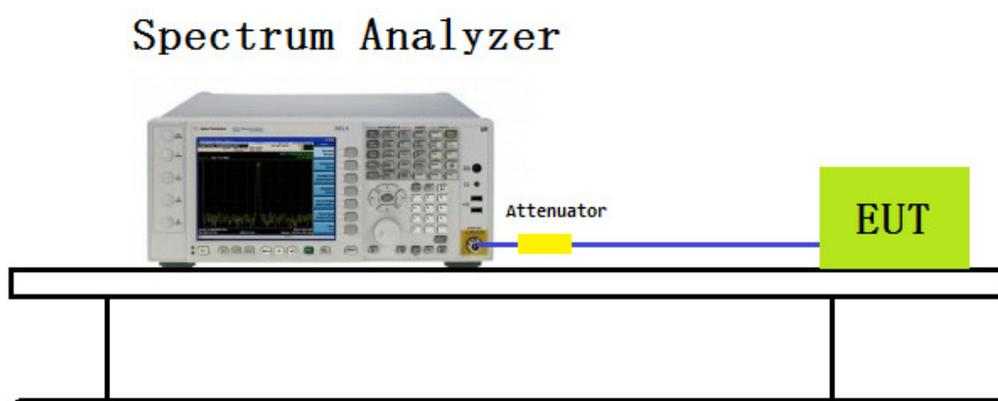



6.5 Test Result and Data

Test Item	6dB Bandwidth Measurement
Test Mode	Transmit by 802.11a
Test Date	2017-07-27

Channel No.	Frequency (MHz)	Measurement Level (MHz)	Result
149	5745	16.57	Pass
157	5785	16.56	Pass
165	5825	16.58	Pass

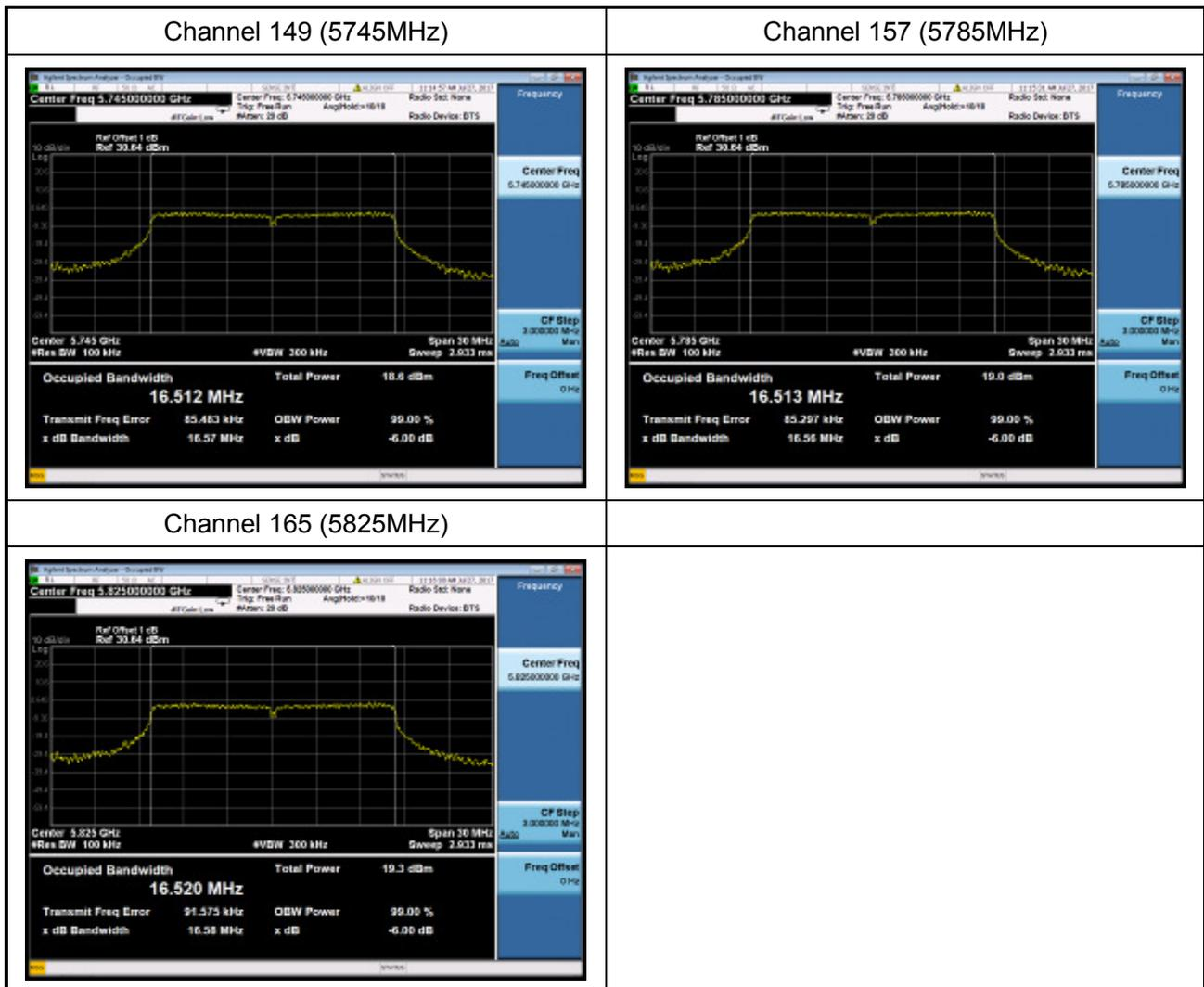



Test Item	6dB Bandwidth Measurement
Test Mode	Transmit by 802.11n(20MHz)
Test Date	2017-07-27

Channel No.	Frequency (MHz)	Measurement Level (MHz)	Result
149	5745	17.82	Pass
157	5785	17.71	Pass
165	5825	17.74	Pass

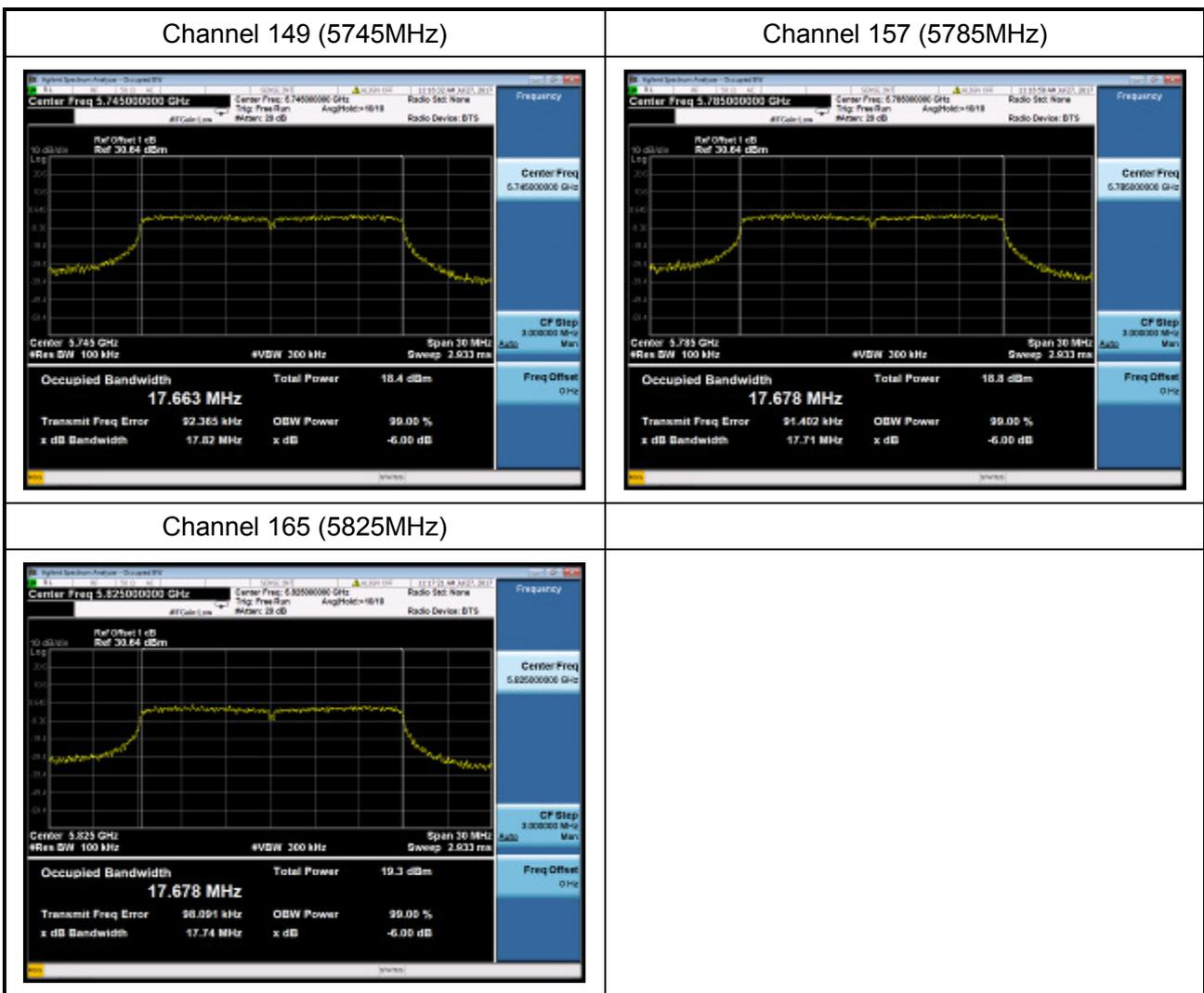



Test Item	6dB Bandwidth Measurement
Test Mode	Transmit by 802.11n(40MHz)
Test Date	2017-07-27

Channel No.	Frequency (MHz)	Measurement Level (MHz)	Result
151	5755	36.51	Pass
159	5795	36.53	Pass

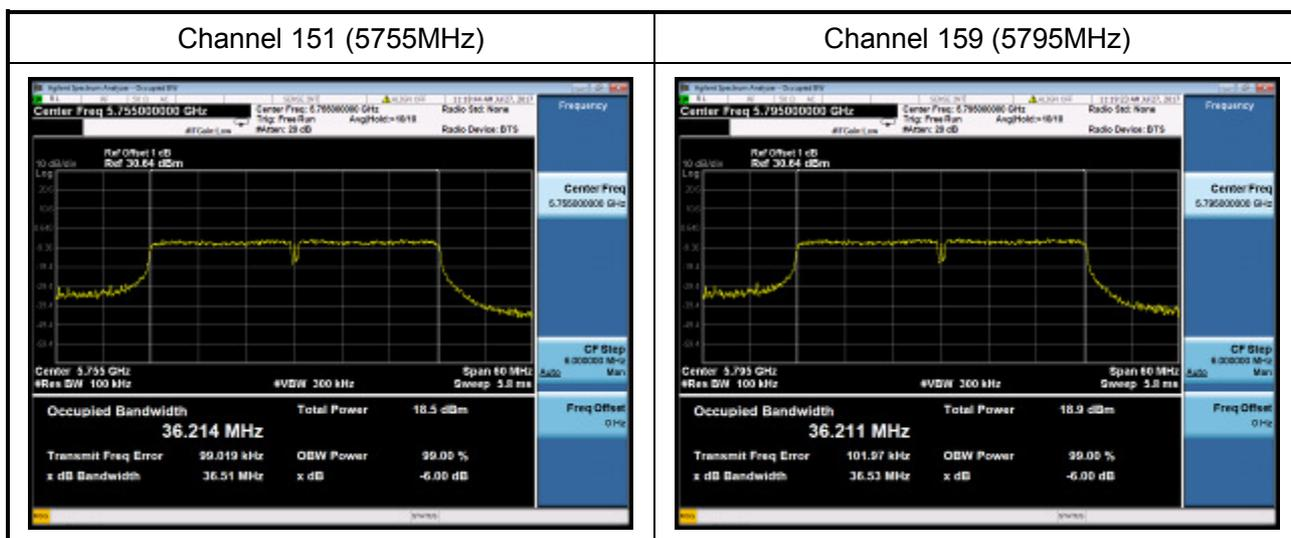



Test Item	6dB Bandwidth Measurement
Test Mode	Transmit by 802.11ac(80MHz)
Test Date	2017-07-27

Channel No.	Frequency (MHz)	Measurement Level (MHz)	Result
155	5775	73.99	Pass

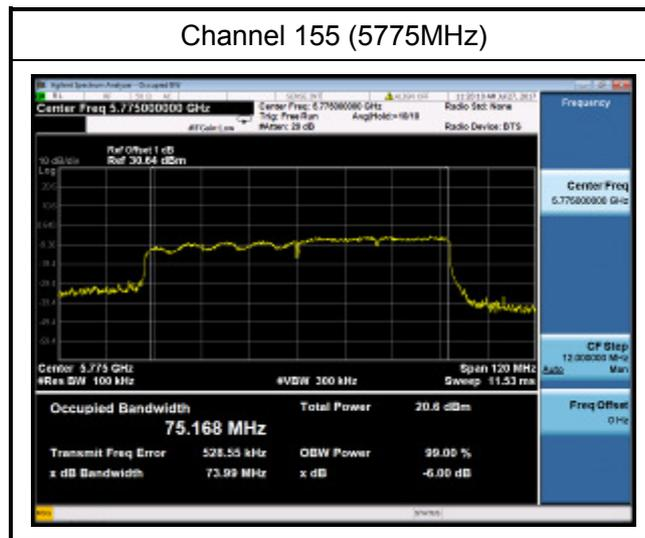



7. Power Output

7.1 Test Limit

According to §15.407(a) Power Limits:

- For an indoor access point operating in the band 5.15-5.25 GHz, the maximum conducted output power over the frequency band of operation shall not exceed 1 W (30dBm).. If transmitting antenna of directional gain greater than 6 dBi are used, the maximum conducted output power shall be reduced by the amount in dB that directional gain of the antenna exceeds 6 dBi.
- For the band 5.25-5.35 GHz and 5.47-5.725 GHz bands, the maximum conducted output power over the frequency bands of operation shall not exceed the lesser of 250 mW or $11 \text{ dBm} + 10 \log B$, where B is the 26 dB emission bandwidth in megahertz. If transmitting antenna of directional gain greater than 6 dBi are used, the maximum conducted output power shall be reduced by the amount in dB that directional gain of the antenna exceeds 6 dBi.
- For the band 5.725-5.825 GHz, the maximum conducted output power over the frequency band of operation shall not exceed the lesser of 1 W or $17 \text{ dBm} + 10 \log B$, where B is the 26 dB emission bandwidth in MHz. If transmitting antenna of directional gain greater than 6 dBi are used, the maximum conducted output power shall be reduced by the amount in dB that directional gain of the antenna exceeds 6 dBi. However, fixed point-to-point U-NII devices operating in this band may employ transmitting antenna with directional gain up to 23 dBi without any corresponding reduction in the transmitter peak output power. For fixed, point-to-point U-NII transmitters that employ a directional antenna gain greater than 23 dBi, a 1 dB reduction in peak transmitter power for each 1 dB of antenna gain in excess of 23 dBi would be required.

5.15-5.25 GHz: Limit (dBm) = 30dBm

5.725-5.85 GHz Limit (dBm) = 30dBm

7.2 Test Standard

KDB 789033 D02v01r04 - Section E) 3) b) Method PM-G



7.3 Test Procedures

Measurements may be performed using a wideband gated RF power meter provided that the gate parameters are adjusted such that the power is measured only when the EUT is transmitting at its maximum power control level. Since the measurement is made only during the ON time of the transmitter, no duty cycle correction factor is required.

7.4 Test Setup

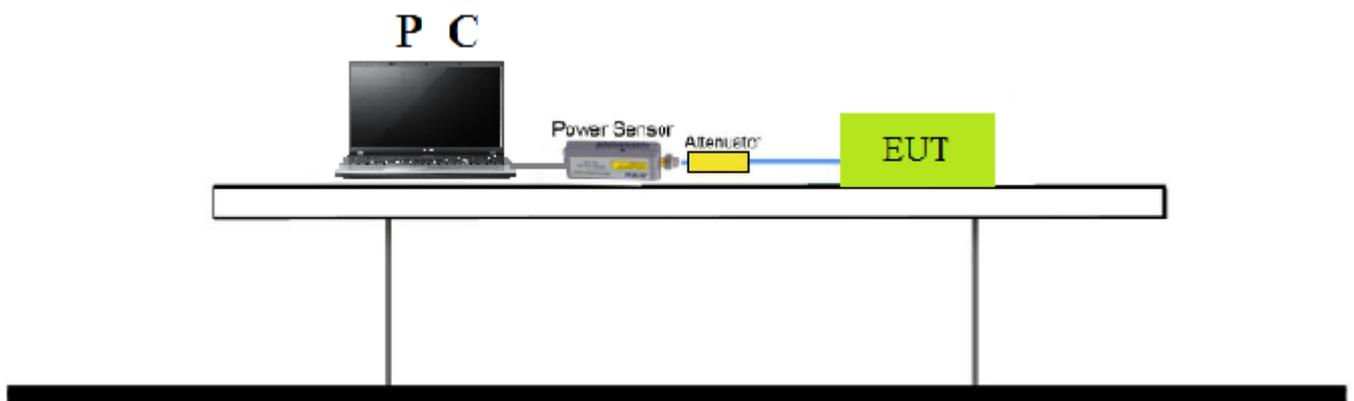



7.5 Test Result and Data

Power output test was verified over all data rates of each mode shown as below, and then choose the maximum power output (yellow marker) for final test of each channel.

MCS Index for 802.11n	Spatial Streams	Data Rate (Mbps)				
		802.11a	20MHz Bandwidth		40MHz Bandwidth	
			800ns GI	400ns GI	800ns GI	400ns GI
0	1	6	6.5	7.2	13.5	15.0
1	1	9	13.0	14.4	27.0	30.0
2	1	12	19.5	21.7	40.5	45.0
3	1	18	26.0	28.9	54.0	60.0
4	1	24	39.0	43.3	81.0	90.0
5	1	36	52.0	57.8	108.0	120.0
6	1	48	58.5	65.0	121.5	135.0
7	1	54	65.0	72.2	135.0	150.0
8	2	---	13.0	14.4	27.0	30.0
9	2	---	26.0	28.9	54.0	60.0
10	2	---	39.0	43.3	81.0	90.0
11	2	---	52.0	57.8	108.0	120.0
12	2	---	78.0	86.7	162.0	180.0
13	2	---	104.0	115.6	216.0	240.0
14	2	---	117.0	130.0	243.0	270.0
15	2	---	130.0	144.0	270.0	300.0



Spatial Streams	MCS Index	Modulation type	Coding rate	Data Rate(Mb/s)							
				20MHz		40MHz		80MHz		160MHz	
				Guard Interval		Guard Interval		Guard Interval		Guard Interval	
				800ns	400ns	800ns	400ns	800ns	400ns	800ns	400ns
1	0	BPSK	1/2	6.5	7.2	13.5	15	29.3	32.5	58.5	65
	1	QPSK	1/2	13	14.4	27	30	58.5	65	117	130
	2	QPSK	3/4	19.5	21.7	40.5	45	87.8	97.5	175.5	195
	3	16-QAM	1/2	26	28.9	54	60	117	130	234	260
	4	16-QAM	3/4	39	43.3	81	90	175.5	195	351	390
	5	64-QAM	2/3	52	57.8	108	120	234	260	468	520
	6	64-QAM	3/4	58.5	65	121.5	135	263.3	292.5	526.5	585
	7	64-QAM	5/6	65	72.2	135	150	292.5	325	585	650
	8	256-QAM	3/4	78	86.7	162	180	351	390	702	780
	9	256-QAM	5/6	N/A	N/A	180	200	390	433.3	780	866.7
2	0	BPSK	1/2	13	14.4	27	30	58.6	65	117	130
	1	QPSK	1/2	26	28.8	54	60	117	130	234	260
	2	QPSK	3/4	39	43.4	81	90	175.6	195	351	390
	3	16-QAM	1/2	52	57.8	108	120	234	260	468	520
	4	16-QAM	3/4	78	86.6	162	180	351	390	702	780
	5	64-QAM	2/3	104	115.6	216	240	468	520	936	1040
	6	64-QAM	3/4	117	130	243	270	526.6	585	1053	1170
	7	64-QAM	5/6	130	144.4	270	300	585	650	1170	1300
	8	256-QAM	3/4	156	173.4	324	360	702	780	1404	1560
	9	256-QAM	5/6	N/A	N/A	360	400	780	866.6	1560	1733.4



Test Mode	Data Rate (Mbps)	Channel No.	Freq. (MHz)	Average Power (dBm)	Limit (dBm)	Result
802.11a	13	36	5180	15.94	30	Pass
		44	5220	16.71	30	Pass
		48	5240	16.94	30	Pass
		149	5745	12.81	30	Pass
		157	5785	12.68	30	Pass
		165	5825	12.90	30	Pass
802.11n(20MHz)	13	36	5180	15.74	30	Pass
		44	5220	16.58	30	Pass
		48	5240	16.79	30	Pass
		149	5745	12.72	30	Pass
		157	5785	12.64	30	Pass
		165	5825	12.86	30	Pass
802.11n(40MHz)	27	38	5190	15.45	30	Pass
		46	5230	16.16	30	Pass
		151	5755	12.28	30	Pass
		159	5795	12.28	30	Pass
802.11ac(80MHz)	58.6	42	5210	15.28	30	Pass
		155	5775	11.73	30	Pass



Test Mode	Data Rate (Mbps)	Channel No.	Freq. (MHz)	Average Power (dBm)	EIRP (dBm)	Limit (dBm)	Result
802.11a	13	36	5180	15.94	17.93	30	Pass
		44	5220	16.71	18.70	30	Pass
		48	5240	16.94	18.93	30	Pass
802.11n(20 MHz)	13	36	5180	15.74	17.73	30	Pass
		44	5220	16.58	18.57	30	Pass
		48	5240	16.79	18.78	30	Pass
802.11n(40 MHz)	27	38	5190	15.45	17.44	30	Pass
		46	5230	16.16	18.15	30	Pass
802.11ac(80MHz)	58.6	42	5210	15.28	17.27	30	Pass

EIRP= Average Power + Antenna Gain



8. Power Spectral Density

8.1 Test Limit

According to FCC 47 CFR Section 15.407 a) PSD Limits:

For an indoor access point operating in the band 5.15-5.25 GHz, the maximum power spectral density shall not exceed 17 dBm in any 1 megahertz band.

For the 5.25-5.35 GHz and 5.47-5.725 GHz bands, the maximum power spectral density shall not exceed 11 dBm in any 1 megahertz band.

For the band 5.725-5.85 GHz, the maximum power spectral density shall not exceed 30 dBm in any 500-kHz band.

If transmitting antennas of directional gain greater than 6dBi are used, the peak power spectral density shall be reduced by the amount in dB that the directional gain of the antenna exceeds 6dBi.

5.15-5.25 GHz: Limit (dBm) = 17dBm/MHz

5.725-5.85 GHz Limit (dBm/500kHz) = 30dBm/500kHz

8.2 Test Standard

KDB 789033 D02v01r04 - Section F



8.3 Test Procedures

1. Analyzer was set to the center frequency of the UNII channel under investigation
2. Span was set to encompass the entire 26dB EBW of the signal.
3. RBW = 1MHz, if measurement bandwidth of Maximum PSD is specified in 500 kHz, RBW = 100 kHz
4. VBW = 3MHz
5. Number of sweep points $\geq 2 \times (\text{span} / \text{RBW})$
6. Detector = power averaging (RMS)
7. Sweep time = auto
8. Trigger = free run
9. Use the peak search function on the instrument to find the peak of the spectrum and record its value.
10. Add $10 \cdot \log(1/x)$, where x is the duty cycle, to the measured power in order to compute the average power during the actual transmission times (because the measurement represents an average over both the on and off times of the transmission). For example, add $10 \cdot \log(1/0.25) = 6 \text{ dB}$ if the duty cycle is 25 percent.
11. When the measurement bandwidth of Maximum PSD is specified in 500 kHz, add a constant factor $10 \cdot \log(500\text{kHz}/100\text{kHz}) = 7 \text{ dB}$ to the measured result.

8.4 Test Setup

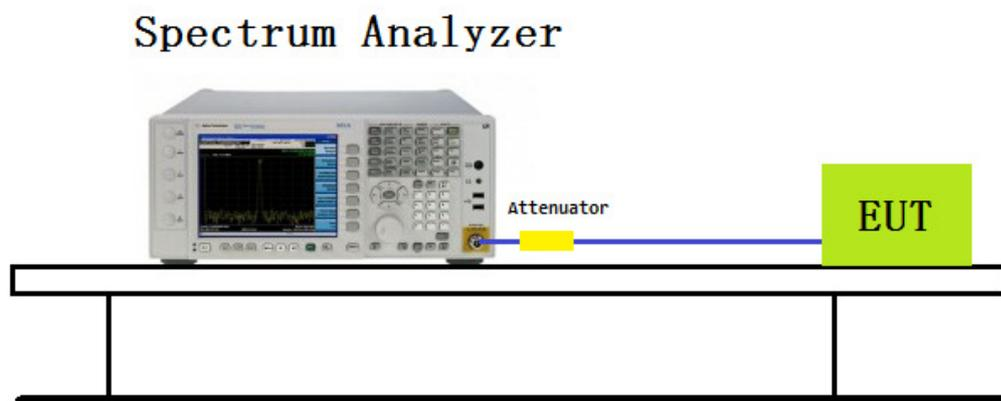

**8.5 Test Result and Data**

Test Mode	Data Rate (Mbps)	Channel No.	Freq. (MHz)	PSD (dBm/MHz)	Limit (dBm/MHz)	Result
802.11a	6	36	5180	9.654	17	Pass
		44	5220	9.711	17	Pass
		48	5240	10.142	17	Pass
802.11n (20MHz)	13	36	5180	8.132	17	Pass
		44	5220	8.922	17	Pass
		48	5240	9.181	17	Pass
802.11n (40MHz)	27	38	5190	4.809	17	Pass
		46	5230	5.307	17	Pass
802.11ac (80MHz)	58.6	42	5210	3.191	17	Pass

Test Mode	Data Rate (Mbps)	CH.	Freq. (MHz)	Measured PSD(dBm/500K Hz)	Constant Factor	Total PSD	Limit (dBm/500kHz)	Result
802.11a	6	149	5745	-0.760	7	6.240	30	Pass
		157	5785	-0.298	7	6.702	30	Pass
		165	5825	-0.268	7	6.732	30	Pass
802.11n (20MHz)	13	149	5745	-0.576	7	6.424	30	Pass
		157	5785	-0.902	7	6.098	30	Pass
		165	5825	-0.487	7	6.513	30	Pass
802.11n (40MHz)	27	151	5755	-5.619	7	1.381	30	Pass
		159	5795	-5.986	7	1.014	30	Pass
802.11ac (80MHz)	58.6	155	5775	-8.719	7	-1.719	30	Pass

Note: Total PSD = Measured PSD + Constant Factor.



802.11a Power Spectral Density

Channel 36 (5180MHz)

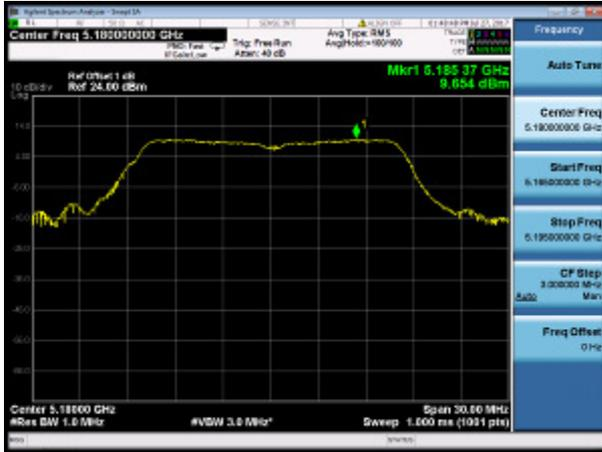

Channel 44 (5220MHz)

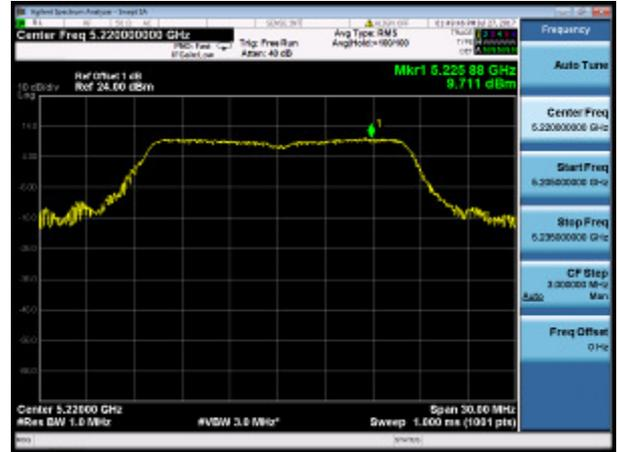

Channel 48 (5240MHz)

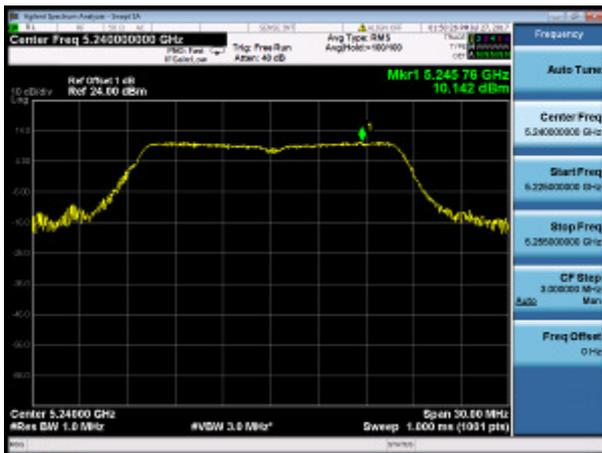

Channel 149 (5745MHz)

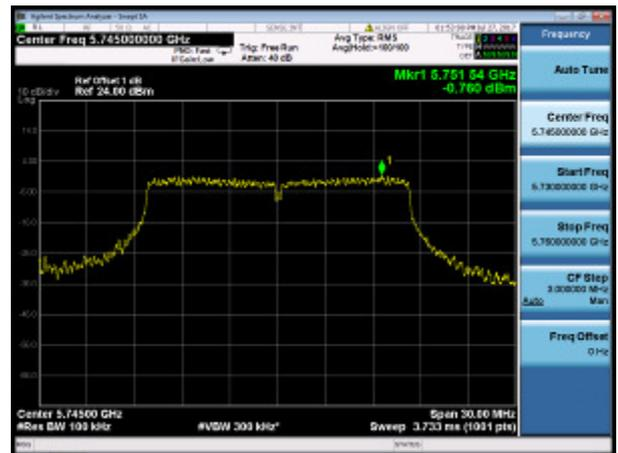

Channel 157 (5785MHz)

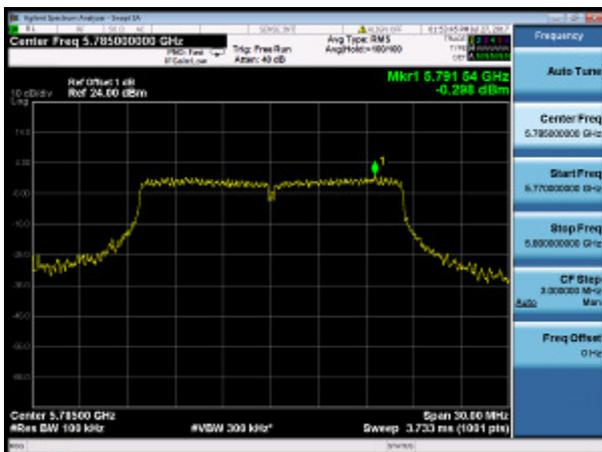

Channel 165 (5825MHz)

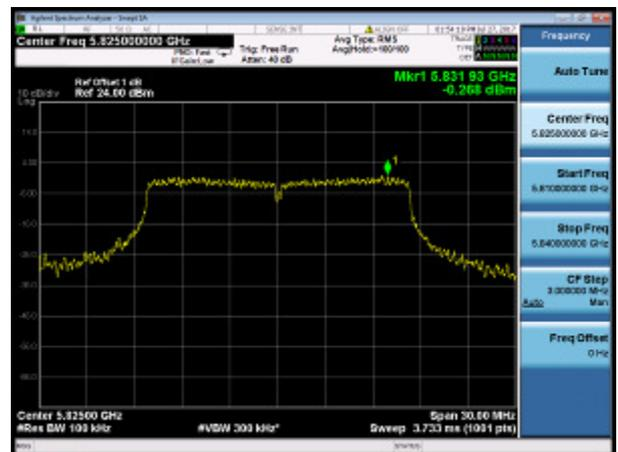



802.11 n(20MHz) Power Spectral Density

Channel 36 (5180MHz)

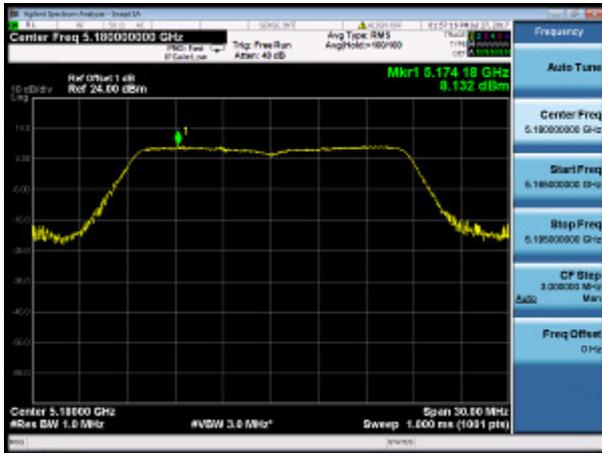

Channel 44 (5220MHz)

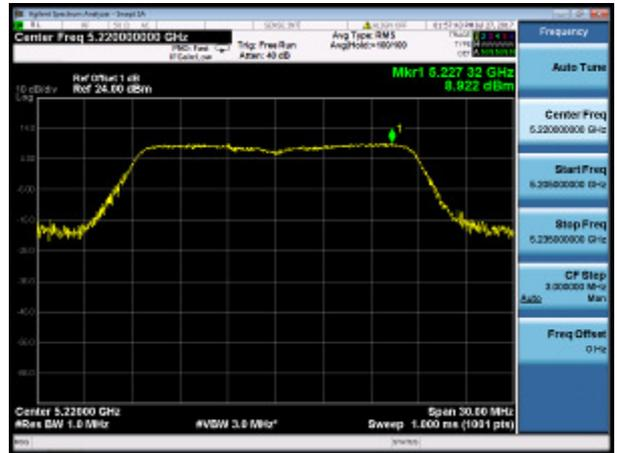

Channel 48 (5240MHz)

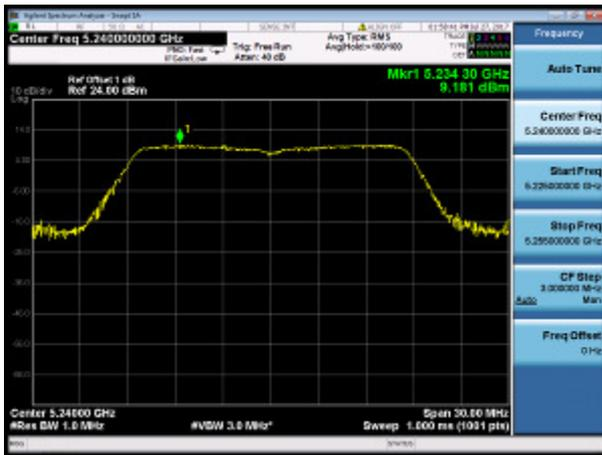

Channel 149 (5745MHz)

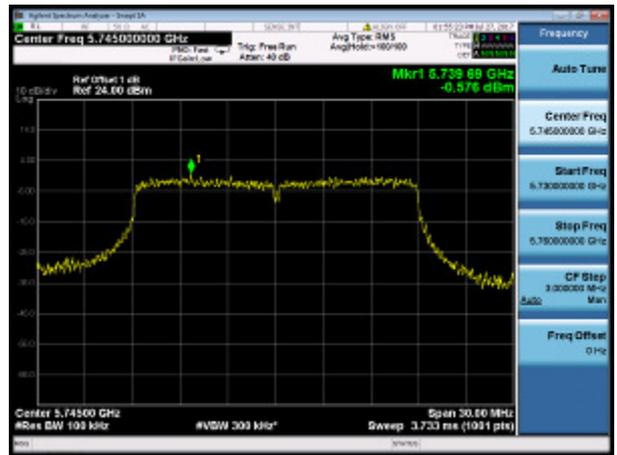

Channel 157 (5785MHz)

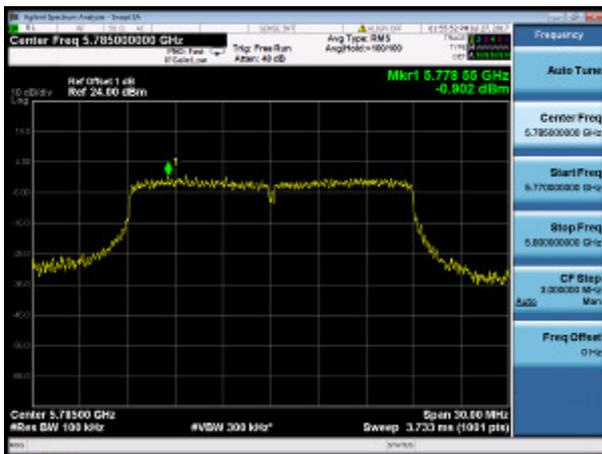

Channel 165 (5825MHz)

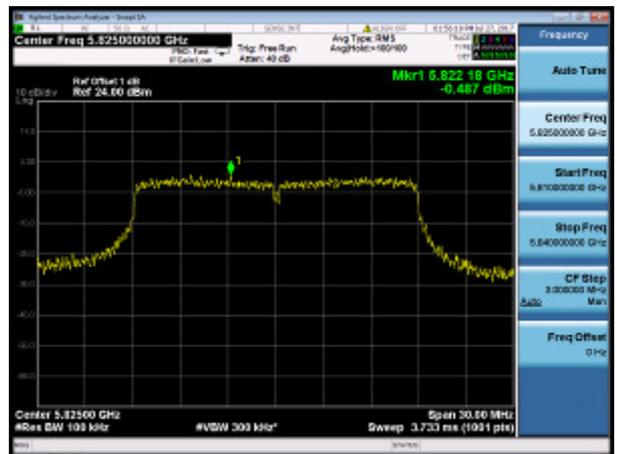



802.11n(40MHz) Power Spectral Density

Channel 38 (5190MHz)



Channel 46 (5230MHz)

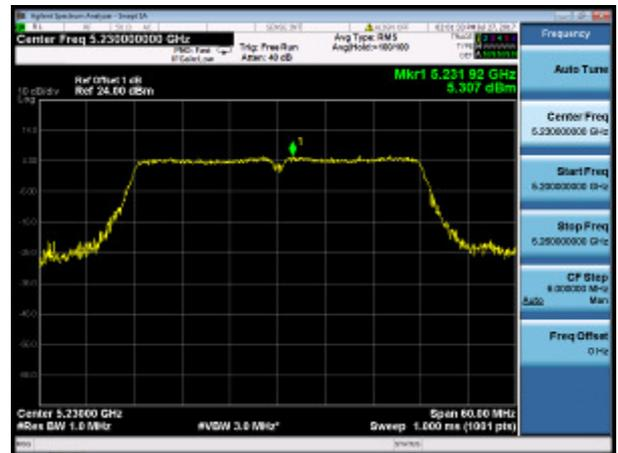

Channel 155 (5755MHz)

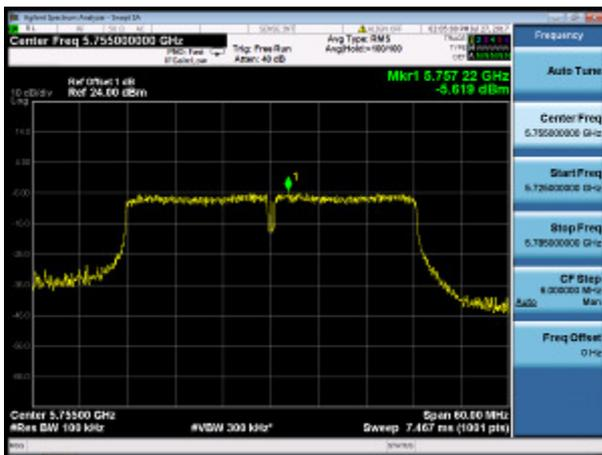

Channel 159 (5795MHz)

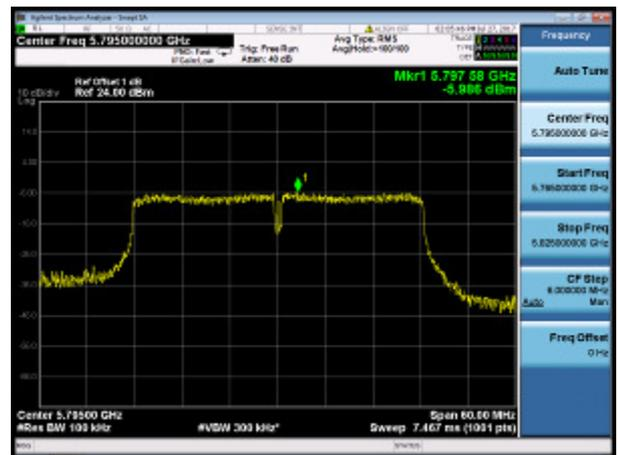



802.11ac(80MHz) Power Spectral Density

Channel 42 (5210MHz)



Channel 155 (5775MHz)





9. Band Edges Measurement

9.1 Test Limit

For 15.205 requirement:

Radiated emissions which fall in the restricted bands, as defined in Section 15.205(a) of FCC part 15, must also comply with the radiated emission limits specified in Section 15.209(a).

MHz	MHz	MHz	GHz
0.090 - 0.110	16.42 - 16.423	399.9 - 410	4.5 - 5.15
¹ 0.495 - 0.505	16.69475 - 16.69525	608 - 614	5.35 - 5.46
2.1735 - 2.1905	16.80425 - 16.80475	960 - 1240	7.25 - 7.75
4.125 - 4.128	25.5 - 25.67	1300 - 1427	8.025 - 8.5
4.17725 - 4.17775	37.5 - 38.25	1435 - 1626.5	9.0 - 9.2
4.20725 - 4.20775	73 - 74.6	1645.5 - 1646.5	9.3 - 9.5
6.215 - 6.218	74.8 - 75.2	1660 - 1710	10.6 - 12.7
6.26775 - 6.26825	108 - 121.94	1718.8 - 1722.2	13.25 - 13.4
6.31175 - 6.31225	123 - 138	2200 - 2300	14.47 - 14.5
8.291 - 8.294	149.9 - 150.05	2310 - 2390	15.35 - 16.2
8.362 - 8.366	156.52475 - 156.52525	2483.5 - 2500	17.7 - 21.4
8.37625 - 8.38675	156.7 - 156.9	2690 - 2900	22.01 - 23.12
8.41425 - 8.41475	162.0125 - 167.17	3260 - 3267	23.6 - 24.0
12.29 - 12.293	167.72 - 173.2	3332 - 3339	31.2 - 31.8
12.51975 - 12.52025	240 - 285	3345.8 - 3358	36.43 - 36.5
12.57675 - 12.57725	322 - 335.4	3600 - 4400	(²)

**For 15.407(b) requirement:**

For transmitters operating in the 5.15-5.25 GHz band: all emissions outside of the 5.15-5.35 GHz band shall not exceed an EIRP of -27 dBm/MHz.

Operating Frequency Band (MHz)	EIRP Limit (dBm/MHz)	Equivalent Field Strength at 3m (dBuV/m)
5150 - 5350	-27	68.2
5470 - 5725	-27	68.2

For transmitters operating in the 5.725-5.85 GHz band:

All emissions shall be limited to a level of -27 dBm/MHz at 75 MHz or more above or below the band edge increasing linearly to 10 dBm/MHz at 25 MHz above or below the band edge, and from 25 MHz above or below the band edge increasing linearly to a level of 15.6 dBm/MHz at 5 MHz above or below the band edge, and from 5 MHz above or below the band edge increasing linearly to a level of 27 dBm/MHz at the band edge.

Note:

1. Refer to KDB 789033 D02v01r04 G)2)c), as specified in § 15.407(b)(1)-(3) specifies that emissions outside of the respective U-NII bands are subject to a maximum emission limit of -27 dBm/MHz. § 15.407(b)(4) provides two requirement options for devices that operate in the 5.725 – 5.85 GHz band. If the option specified in § 15.407(b)(4)(ii) is exercised, then the procedures specified in Clause 11.11 of ANSI C63.10-2013 and/or in Section 11.0 of KDB Publication 558074 shall be utilized. In general, an out-of-band emission that complies with both the peak and average power limits of § 15.209 is not required to also satisfy the -27 dBm/MHz or -17 dBm/MHz maximum emission limit.
2. All out of band emissions appearing in a restricted band as specified in Section 15.205 of the Title 47 CFR must not exceed the limits shown in Table per Section 15.209.

FCC Part 15 Subpart C Paragraph 15.209		
Frequency [MHz]	Field Strength [V/m]	Measured Distance [Meters]
0.009 – 0.490	2400/F (kHz)	300
0.490 – 1.705	24000/F (kHz)	30
1.705 - 30	30	30
30 - 88	100	3
88 - 216	200	3
216 - 960	200	3
Above 960	500	3



9.2 Test Standard

KDB 789033 D02v01r04 G)2)c)

9.3 Test Procedures

Peak Field Strength Measurements:

Analyzer center frequency was set to the frequency of the radiated spurious emission of interest

1. RBW = 1MHz
2. VBW = 3MHz
3. Detector = peak
4. Sweep time = auto couple
5. Trace mode = max hold
6. Trace was allowed to stabilize

AVE Field Strength Measurements:

(i) RBW = 1 MHz.

(ii) Video bandwidth.

■ If the EUT is configured to transmit with duty cycle $\geq 98\%$, set $VBW \leq RBW/100$ (i.e., 10 kHz) but not less than 10 Hz.

■ If the EUT duty cycle is $< 98\%$, set $VBW \geq 1/T$, where T is defined in section II.B.1.a).

(iii) Video bandwidth mode or display mode

■ The instrument shall be set to ensure that video filtering is applied in the power domain. Typically, this requires setting the detector mode to rms and setting the Average-VBW Type to power averaging (rms).

■ As an alternative, the analyzer may be set to linear detector mode. Ensure that video filtering is applied in linear voltage domain (rather than in a log or dB domain). Some analyzers require linear display mode in order to accomplish this. Others have a setting for Average-VBW Type, which can be set to "Voltage" regardless of the display mode.

(iv) Detector = Peak.

(v) Sweep time = auto.

(vi) Trace mode = max hold.

(vii) Allow max hold to run for at least 50 traces if the transmitted signal is continuous or has at least 98% duty cycle. For lower duty cycles, increase the minimum number of traces by a factor of $1/x$, where x is the duty cycle. For example, use at least 200 traces if the duty cycle is 25%. (If a specific emission is demonstrated to be continuous—i.e., 100% duty cycle—rather than turning on and off with the transmit cycle, at least 50 traces shall be averaged.)



9.4 Test Setup

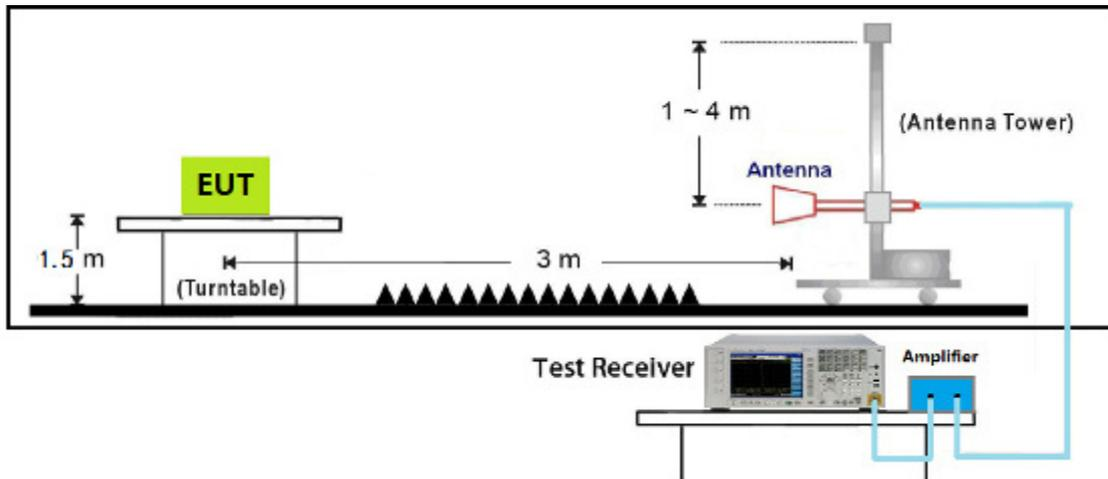



9.5 Test Result and Data

Site:AC102	Time: 2017/07/26 - 18:38
Limit: FCC_Part15.209_RE(3m)	Margin: 0
Probe: N/A	Polarity: Horizontal
EUT: IP CAMERA	Power: 120V/60Hz
Note: Mode:Transmit 802.11a at 5180MHz	

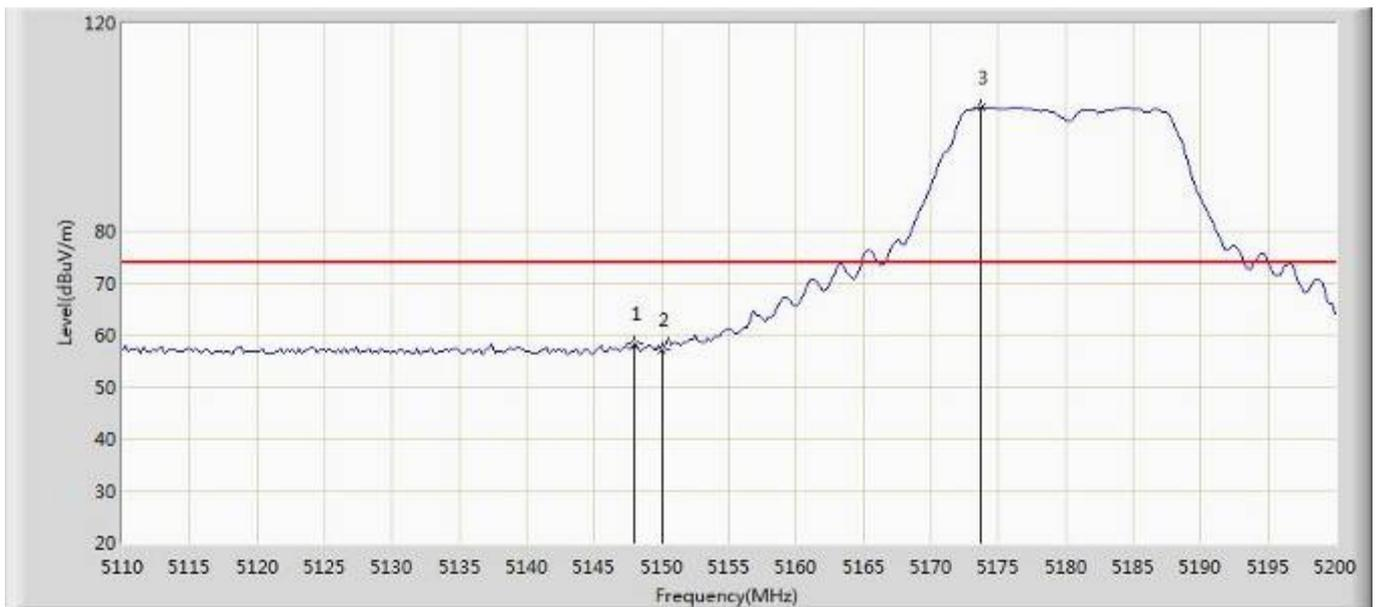

No	Mark	Frequency (MHz)	Measure Level (dBuV/m)	Reading Level (dBuV)	Over Limit (dB)	Limit (dBuV/m)	Factor (dB)	Type
1		5148.025	58.372	54.249	-15.628	74.000	4.123	PK
2		5150.000	57.206	53.077	-16.794	74.000	4.129	PK
3	*	5173.675	103.774	99.572	N/A	N/A	4.202	PK



Site:AC102	Time: 2017/07/26 - 18:58
Limit: FCC_Part15.209_RE(3m)	Margin: 0
Probe: N/A	Polarity: Horizontal
EUT: IP CAMERA	Power: 120V/60Hz
Note: Mode:Transmit 802.11a at 5180MHz	

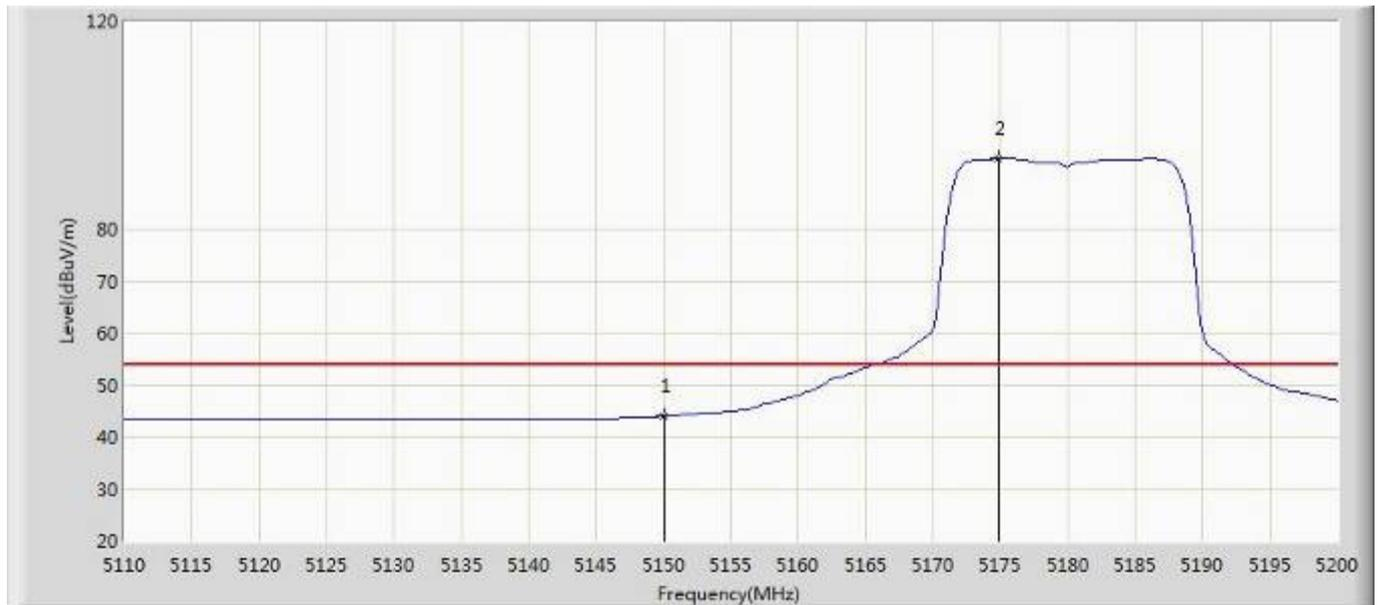

No	Mark	Frequency (MHz)	Measure Level (dBuV/m)	Reading Level (dBuV)	Over Limit (dB)	Limit (dBuV/m)	Factor (dB)	Type
1		5150.000	43.981	39.852	-10.019	54.000	4.129	AV
2	*	5174.800	93.610	89.405	N/A	N/A	4.205	AV



Site:AC102	Time: 2017/07/26 - 18:59
Limit: FCC_Part15.209_RE(3m)	Margin: 0
Probe: N/A	Polarity: Vertical
EUT: IP CAMERA	Power: 120V/60Hz
Note: Mode:Transmit 802.11a at 5180MHz	

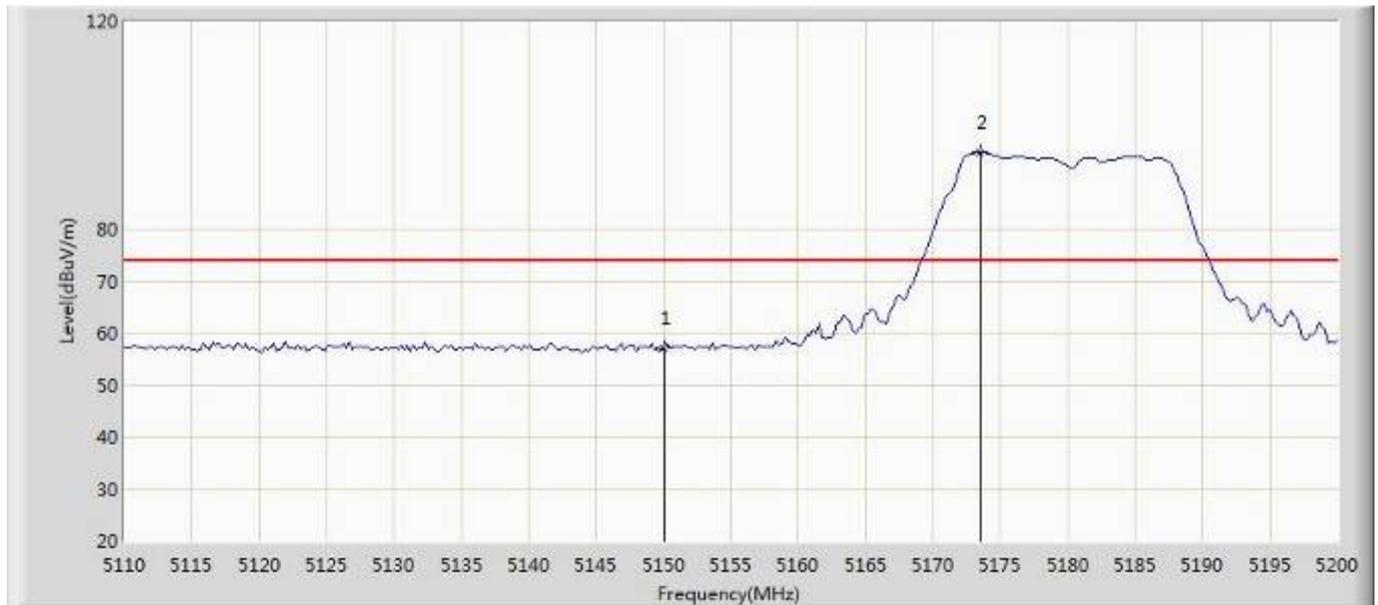

No	Mark	Frequency (MHz)	Measure Level (dBuV/m)	Reading Level (dBuV)	Over Limit (dB)	Limit (dBuV/m)	Factor (dB)	Type
1		5150.000	57.076	52.947	-16.924	74.000	4.129	PK
2	*	5173.450	94.674	90.473	N/A	N/A	4.201	PK



Site:AC102	Time: 2017/07/26 - 19:16
Limit: FCC_Part15.209_RE(3m)	Margin: 0
Probe: N/A	Polarity: Vertical
EUT: IP CAMERA	Power: 120V/60Hz
Note: Mode:Transmit 802.11a at 5180MHz	

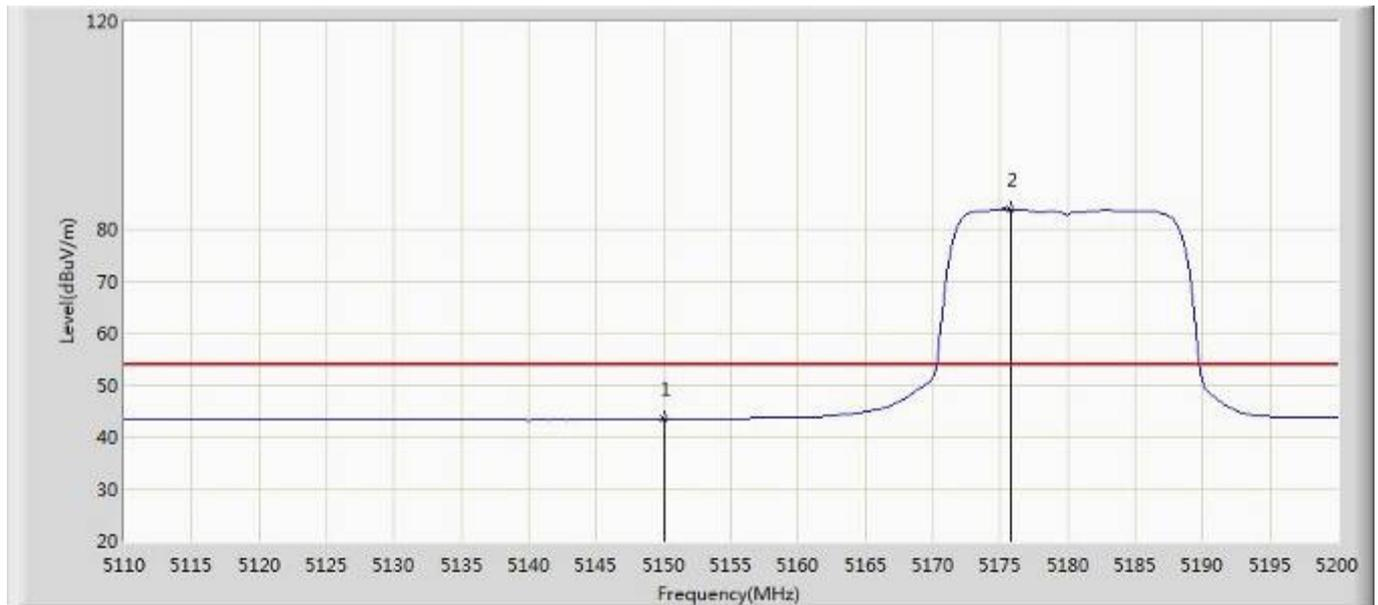

No	Mark	Frequency (MHz)	Measure Level (dBuV/m)	Reading Level (dBuV)	Over Limit (dB)	Limit (dBuV/m)	Factor (dB)	Type
1		5150.000	43.444	39.315	-10.556	54.000	4.129	AV
2	*	5175.700	83.858	79.650	N/A	N/A	4.208	AV



Site:AC102	Time: 2017/07/26 - 19:17
Limit: FCC_Part15.209_RE(3m)	Margin: 0
Probe: N/A	Polarity: Vertical
EUT: IP CAMERA	Power: 120V/60Hz
Note: Mode:Transmit 802.11a at 5240MHz	

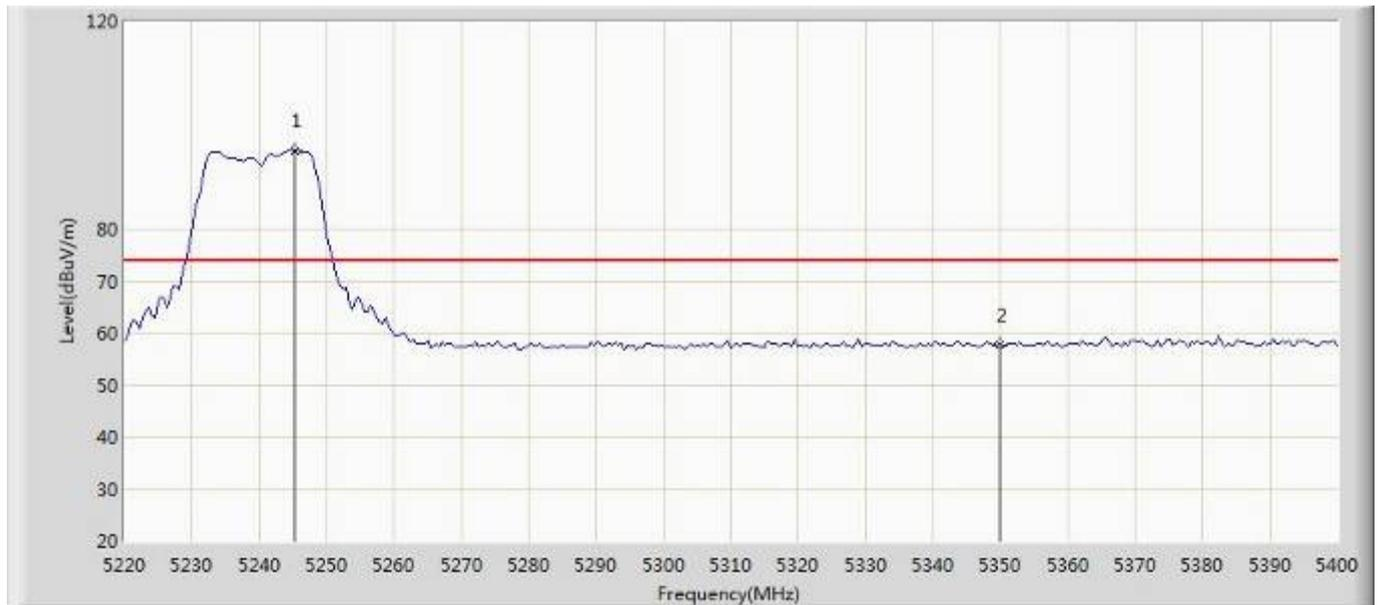

No	Mark	Frequency (MHz)	Measure Level (dBuV/m)	Reading Level (dBuV)	Over Limit (dB)	Limit (dBuV/m)	Factor (dB)	Type
1	*	5245.200	95.192	90.772	N/A	N/A	4.420	PK
2		5350.000	57.797	53.056	-16.203	74.000	4.741	PK



Site:AC102	Time: 2017/07/26 - 19:21
Limit: FCC_Part15.209_RE(3m)	Margin: 0
Probe: N/A	Polarity: Vertical
EUT: IP CAMERA	Power: 120V/60Hz
Note: Mode:Transmit 802.11a at 5240MHz	

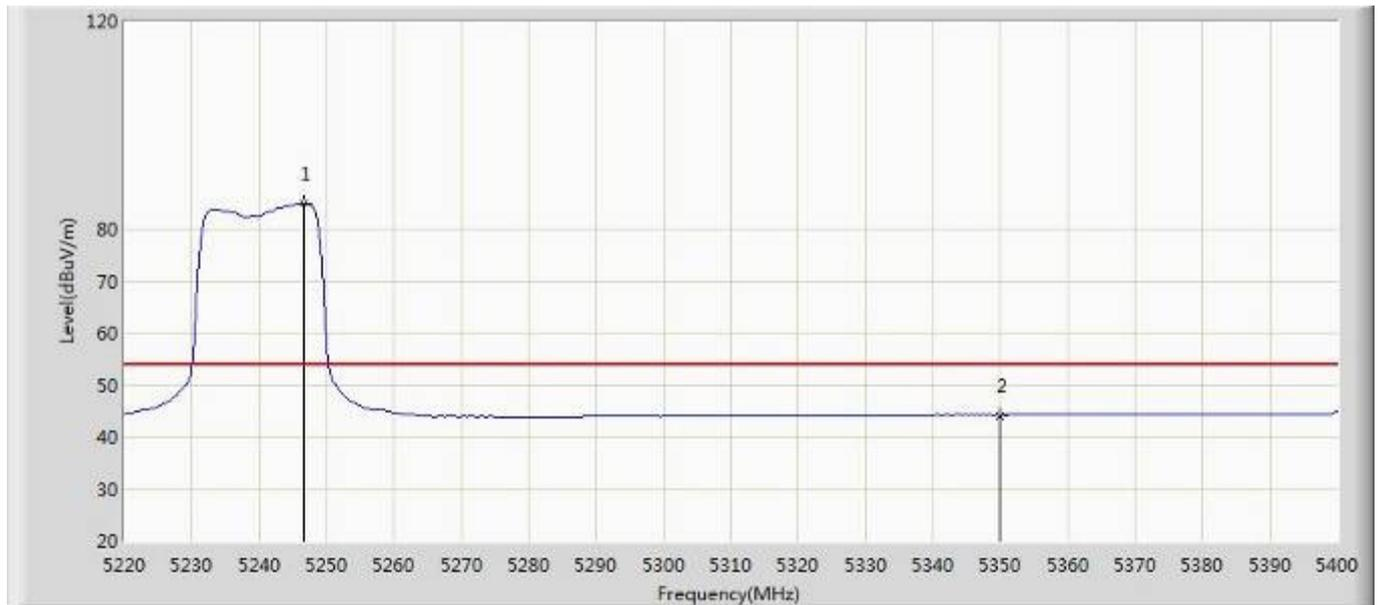

No	Mark	Frequency (MHz)	Measure Level (dBuV/m)	Reading Level (dBuV)	Over Limit (dB)	Limit (dBuV/m)	Factor (dB)	Type
1	*	5246.550	85.019	80.595	N/A	N/A	4.424	AV
2		5350.000	44.200	39.459	-9.800	54.000	4.741	AV



Site:AC102	Time: 2017/07/26 - 19:22
Limit: FCC_Part15.209_RE(3m)	Margin: 0
Probe: N/A	Polarity: Horizontal
EUT: IP CAMERA	Power: 120V/60Hz
Note: Mode:Transmit 802.11a at 5240MHz	

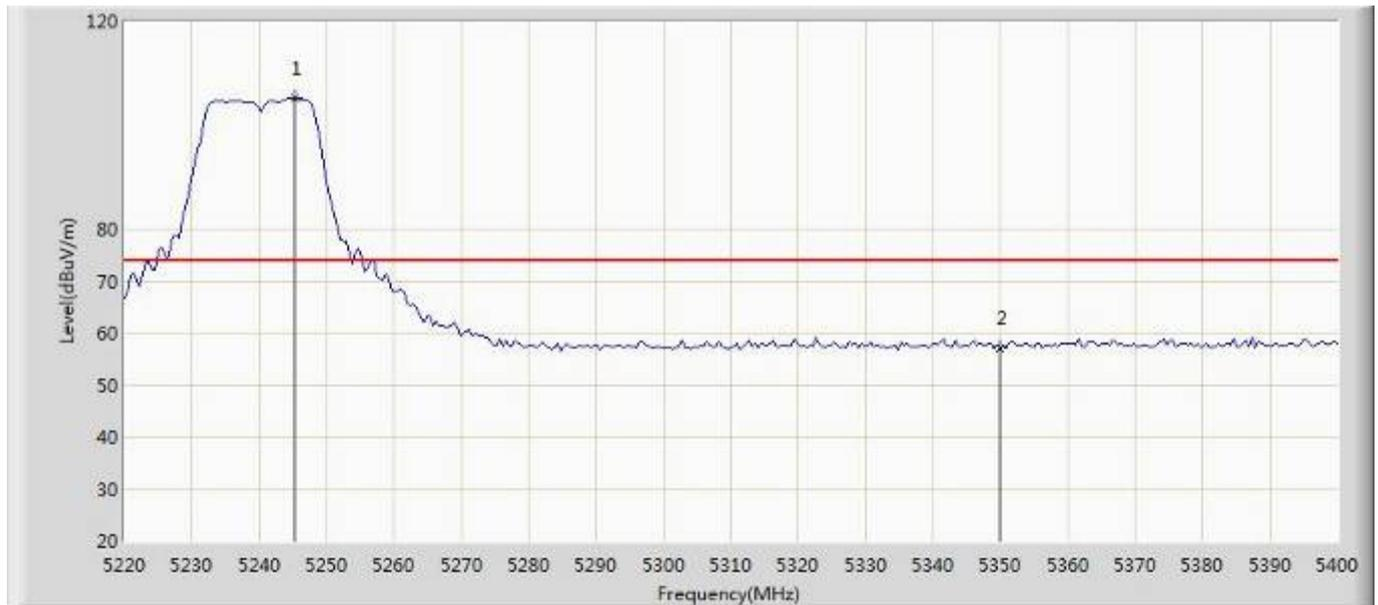

No	Mark	Frequency (MHz)	Measure Level (dBuV/m)	Reading Level (dBuV)	Over Limit (dB)	Limit (dBuV/m)	Factor (dB)	Type
1	*	5245.200	105.188	100.768	N/A	N/A	4.420	PK
2		5350.000	57.159	52.418	-16.841	74.000	4.741	PK



Site:AC102	Time: 2017/07/26 - 19:25
Limit: FCC_Part15.209_RE(3m)	Margin: 0
Probe: N/A	Polarity: Horizontal
EUT: IP CAMERA	Power: 120V/60Hz
Note: Mode:Transmit 802.11a at 5240MHz	

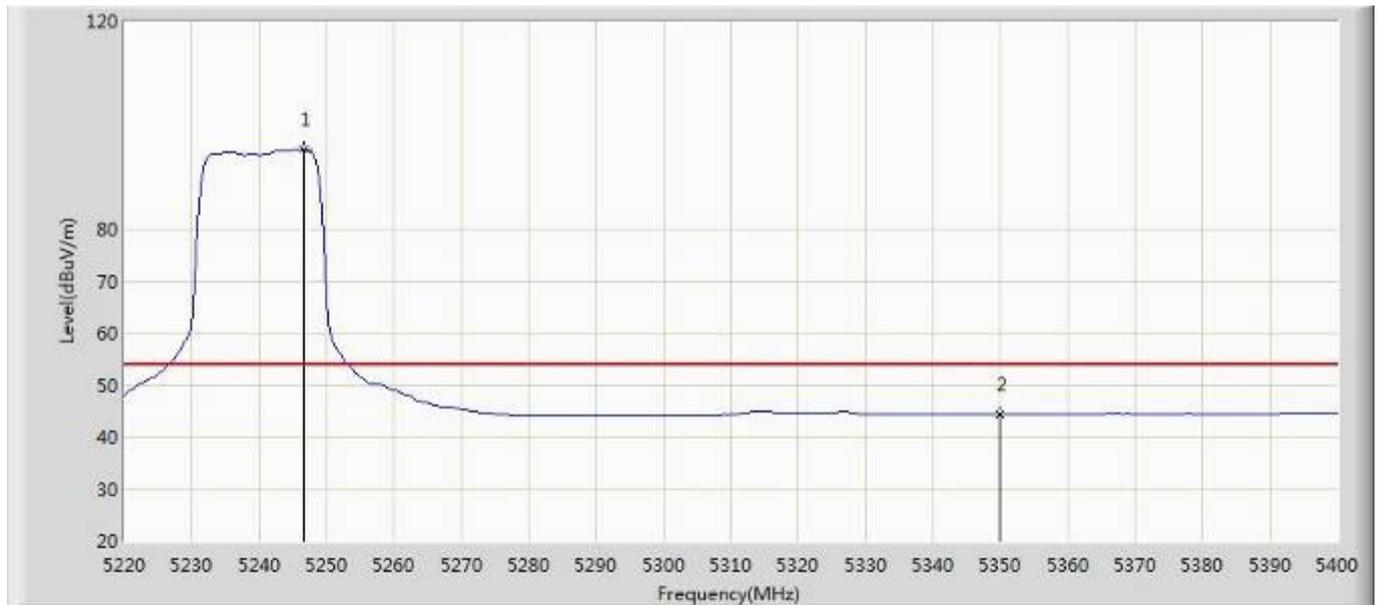

No	Mark	Frequency (MHz)	Measure Level (dBuV/m)	Reading Level (dBuV)	Over Limit (dB)	Limit (dBuV/m)	Factor (dB)	Type
1	*	5246.550	95.375	90.951	N/A	N/A	4.424	AV
2		5350.000	44.314	39.573	-9.686	54.000	4.741	AV



Site:AC102	Time: 2017/07/26 - 19:26
Limit: FCC_Part15.209_RE(3m)	Margin: 0
Probe: N/A	Polarity: Horizontal
EUT: IP CAMERA	Power: 120V/60Hz
Note: Mode:Transmit 802.11n20 at 5180MHz	

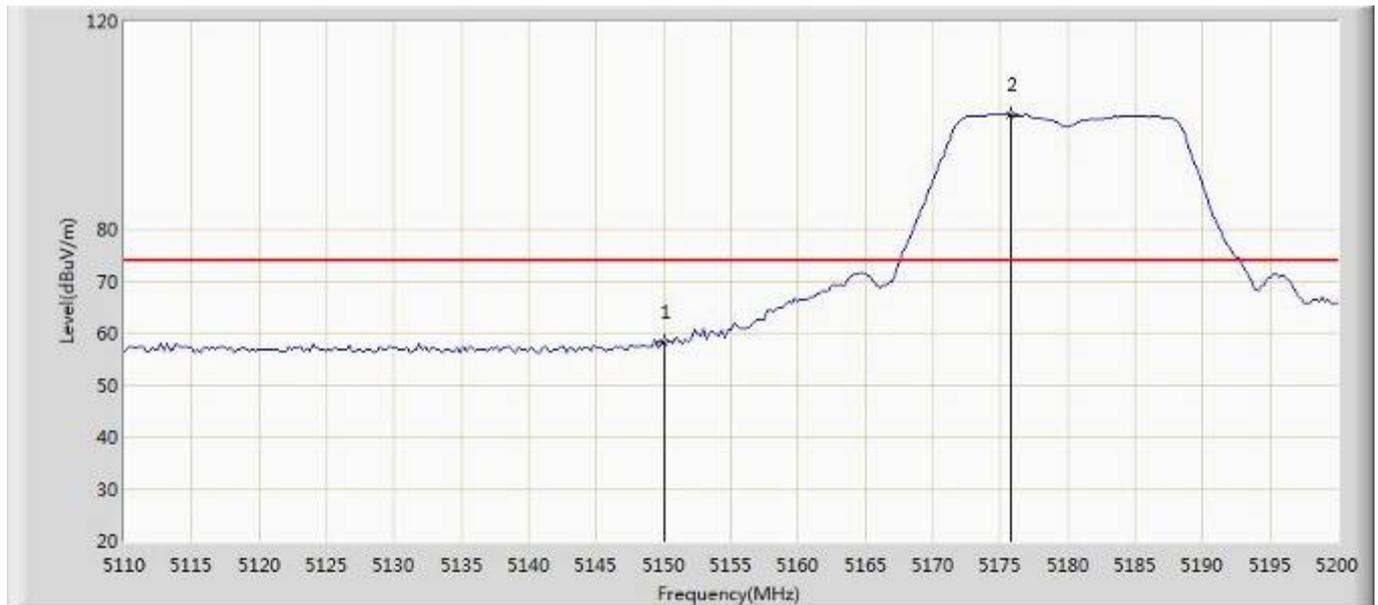

No	Mark	Frequency (MHz)	Measure Level (dBuV/m)	Reading Level (dBuV)	Over Limit (dB)	Limit (dBuV/m)	Factor (dB)	Type
1		5150.000	58.358	54.229	-15.642	74.000	4.129	PK
2	*	5175.700	101.908	97.700	N/A	N/A	4.208	PK



Site:AC102	Time: 2017/07/26 - 19:29
Limit: FCC_Part15.209_RE(3m)	Margin: 0
Probe: N/A	Polarity: Horizontal
EUT: IP CAMERA	Power: 120V/60Hz
Note: Mode:Transmit 802.11n20 at 5180MHz	

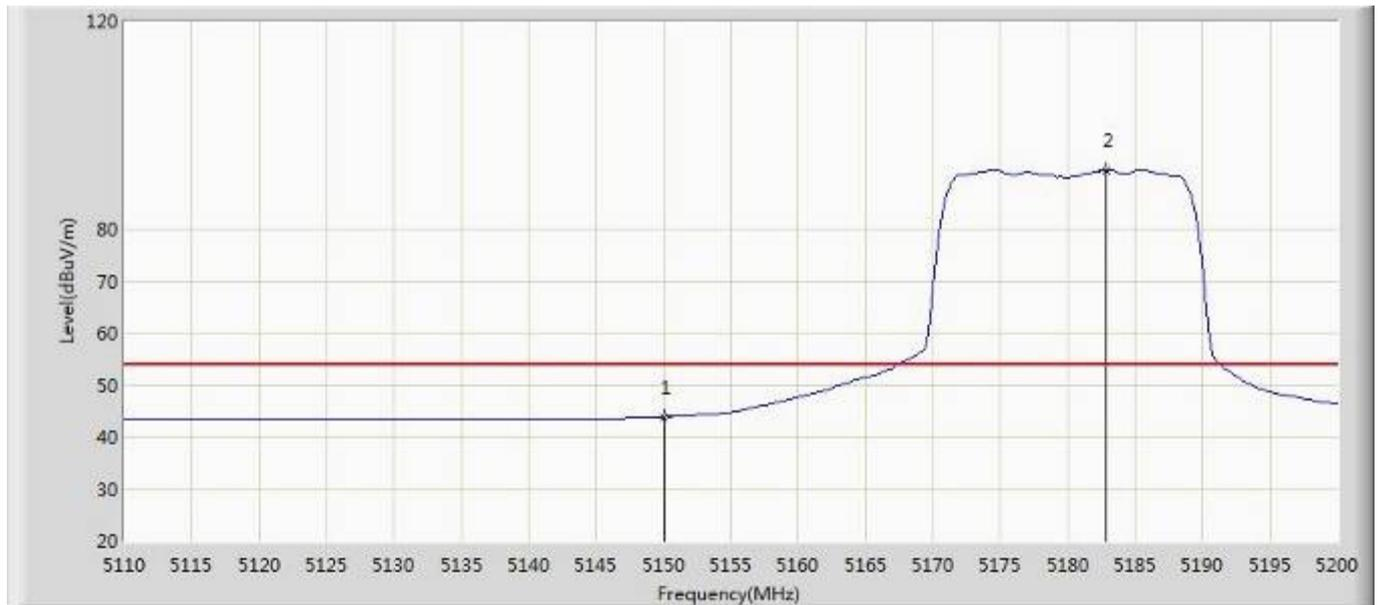

No	Mark	Frequency (MHz)	Measure Level (dBuV/m)	Reading Level (dBuV)	Over Limit (dB)	Limit (dBuV/m)	Factor (dB)	Type
1		5150.000	43.868	39.739	-10.132	54.000	4.129	AV
2	*	5182.900	91.298	87.068	N/A	N/A	4.230	AV



Site:AC102	Time: 2017/07/26 - 19:29
Limit: FCC_Part15.209_RE(3m)	Margin: 0
Probe: N/A	Polarity: Vertical
EUT: IP CAMERA	Power: 120V/60Hz
Note: Mode:Transmit 802.11n20 at 5180MHz	

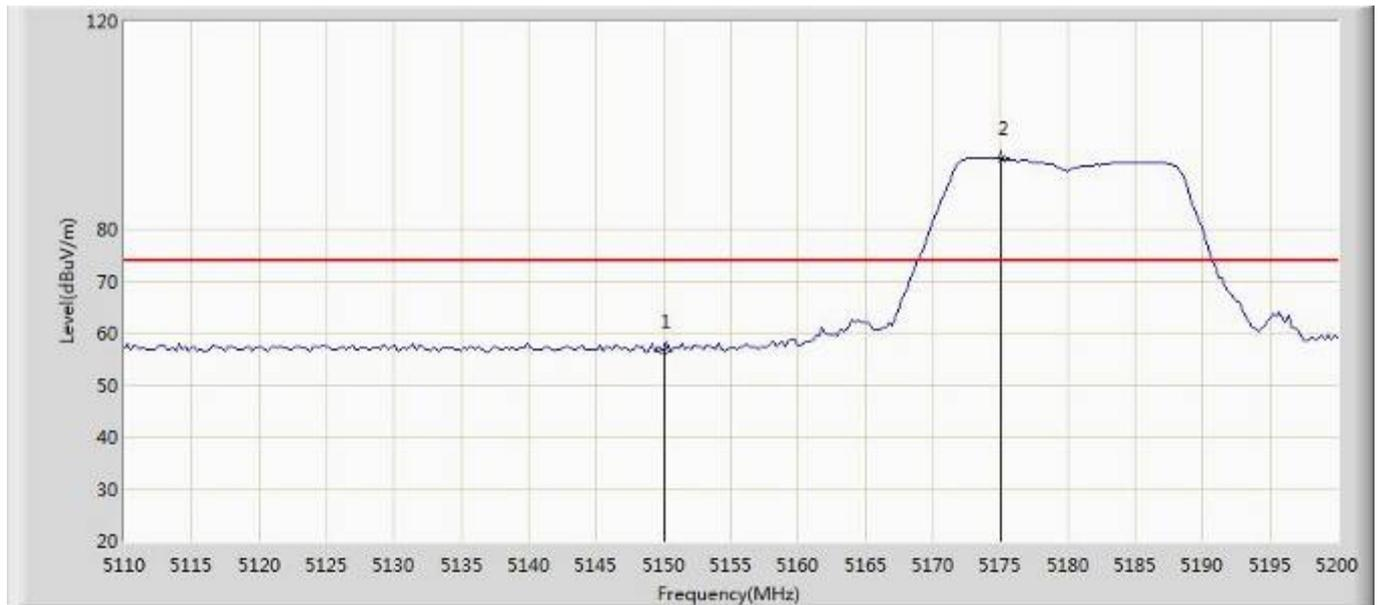

No	Mark	Frequency (MHz)	Measure Level (dBuV/m)	Reading Level (dBuV)	Over Limit (dB)	Limit (dBuV/m)	Factor (dB)	Type
1		5150.000	56.653	52.524	-17.347	74.000	4.129	PK
2	*	5175.025	93.501	89.295	N/A	N/A	4.206	PK



Site:AC102	Time: 2017/07/26 - 19:33
Limit: FCC_Part15.209_RE(3m)	Margin: 0
Probe: N/A	Polarity: Vertical
EUT: IP CAMERA	Power: 120V/60Hz
Note: Mode:Transmit 802.11n20 at 5180MHz	

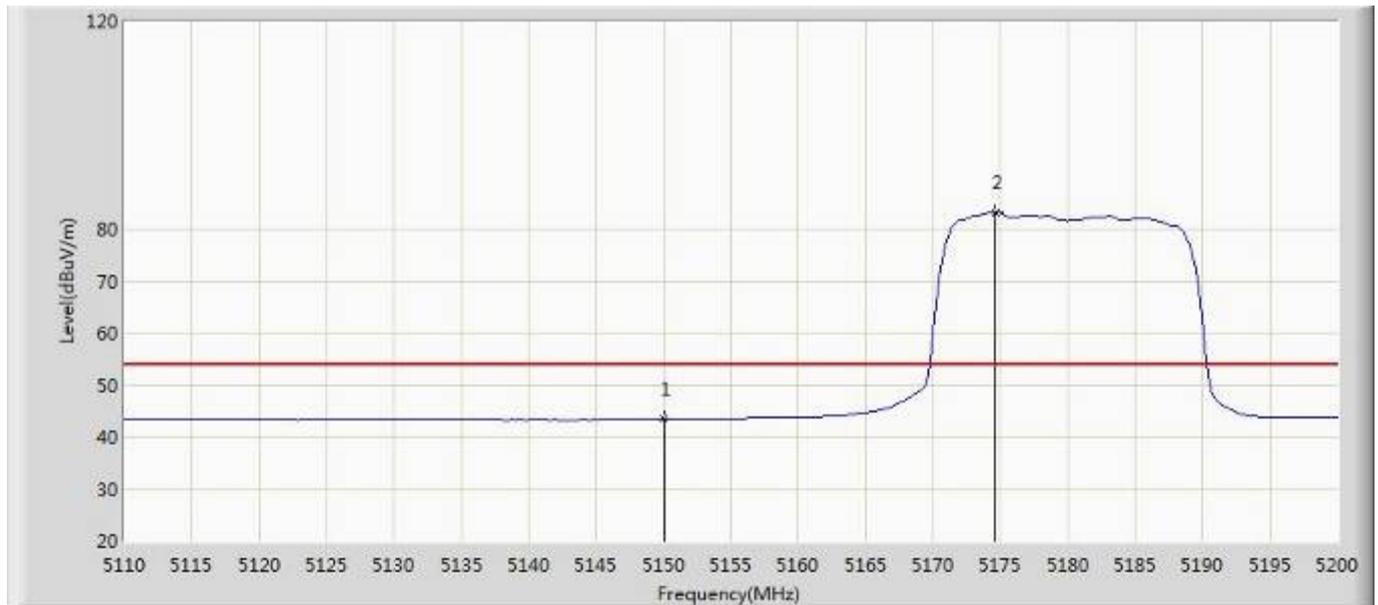

No	Mark	Frequency (MHz)	Measure Level (dBuV/m)	Reading Level (dBuV)	Over Limit (dB)	Limit (dBuV/m)	Factor (dB)	Type
1		5150.000	43.426	39.297	-10.574	54.000	4.129	AV
2	*	5174.575	83.130	78.926	N/A	N/A	4.204	AV



Site:AC102	Time: 2017/07/26 - 19:34
Limit: FCC_Part15.209_RE(3m)	Margin: 0
Probe: N/A	Polarity: Vertical
EUT: IP CAMERA	Power: 120V/60Hz
Note: Mode:Transmit 802.11n20 at 5240MHz	



No	Mark	Frequency (MHz)	Measure Level (dBuV/m)	Reading Level (dBuV)	Over Limit (dB)	Limit (dBuV/m)	Factor (dB)	Type
1	*	5245.200	94.739	90.319	N/A	N/A	4.420	PK
2		5350.000	57.734	52.993	-16.266	74.000	4.741	PK



Site:AC102	Time: 2017/07/26 - 19:38
Limit: FCC_Part15.209_RE(3m)	Margin: 0
Probe: N/A	Polarity: Vertical
EUT: IP CAMERA	Power: 120V/60Hz
Note: Mode:Transmit 802.11n20 at 5240MHz	

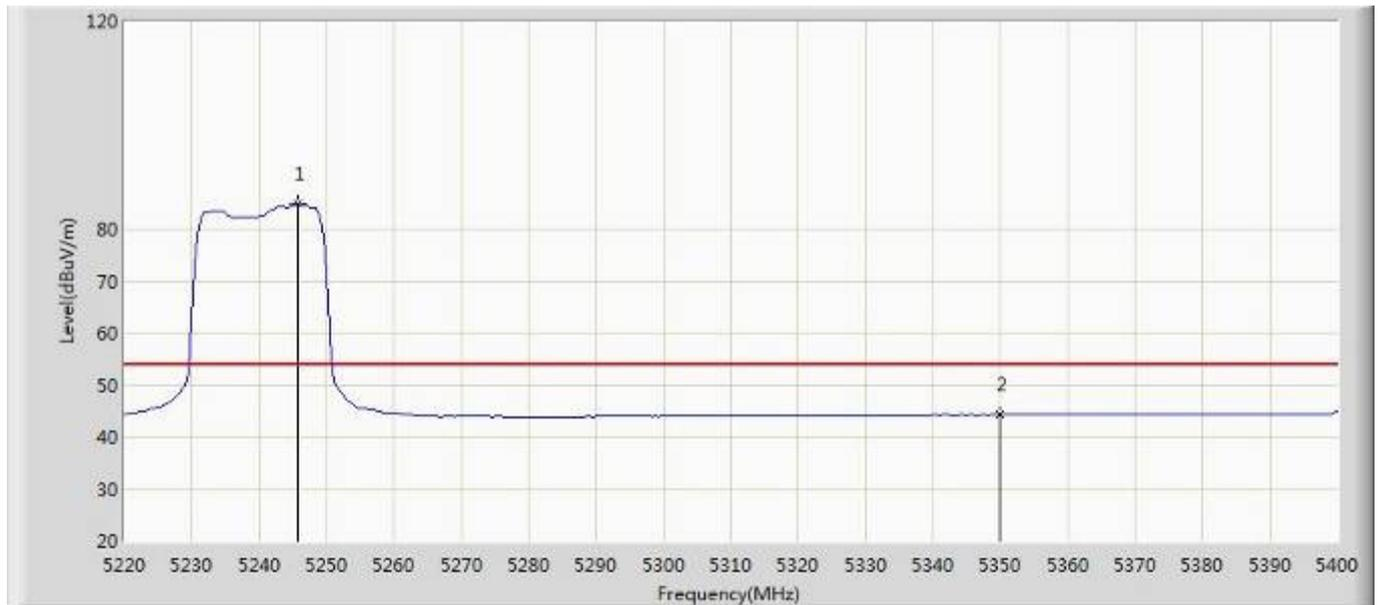

No	Mark	Frequency (MHz)	Measure Level (dBuV/m)	Reading Level (dBuV)	Over Limit (dB)	Limit (dBuV/m)	Factor (dB)	Type
1	*	5245.650	84.814	80.392	N/A	N/A	4.422	AV
2		5350.000	44.248	39.507	-9.752	54.000	4.741	AV



Site:AC102	Time: 2017/07/26 - 19:39
Limit: FCC_Part15.209_RE(3m)	Margin: 0
Probe: N/A	Polarity: Horizontal
EUT: IP CAMERA	Power: 120V/60Hz
Note: Mode:Transmit 802.11n20 at 5240MHz	



No	Mark	Frequency (MHz)	Measure Level (dBuV/m)	Reading Level (dBuV)	Over Limit (dB)	Limit (dBuV/m)	Factor (dB)	Type
1	*	5245.200	104.674	100.254	N/A	N/A	4.420	PK
2		5350.000	57.850	53.109	-16.150	74.000	4.741	PK



Site:AC102	Time: 2017/07/26 - 19:43
Limit: FCC_Part15.209_RE(3m)	Margin: 0
Probe: N/A	Polarity: Horizontal
EUT: IP CAMERA	Power: 120V/60Hz
Note: Mode:Transmit 802.11n20 at 5240MHz	

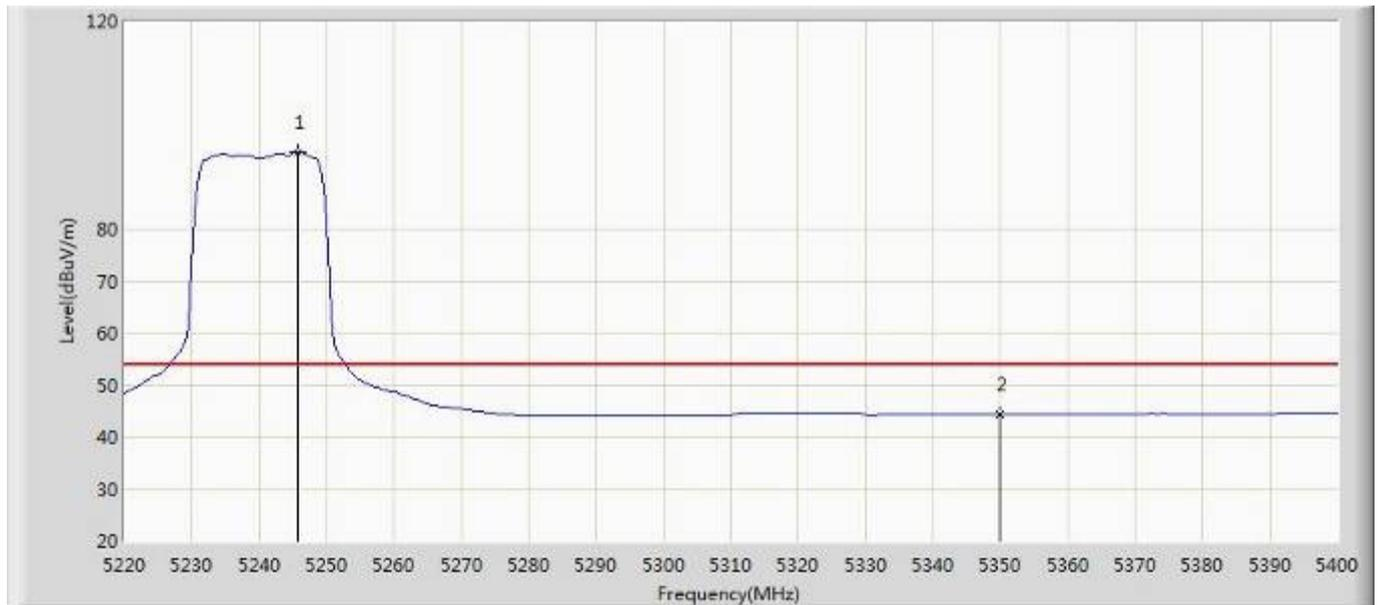

No	Mark	Frequency (MHz)	Measure Level (dBuV/m)	Reading Level (dBuV)	Over Limit (dB)	Limit (dBuV/m)	Factor (dB)	Type
1	*	5245.650	94.765	90.343	N/A	N/A	4.422	AV
2		5350.000	44.327	39.586	-9.673	54.000	4.741	AV



Site:AC102	Time: 2017/07/26 - 19:44
Limit: FCC_Part15.209_RE(3m)	Margin: 0
Probe: N/A	Polarity: Horizontal
EUT: IP CAMERA	Power: 120V/60Hz
Note: Mode:Transmit 802.11n40 at 5190MHz	

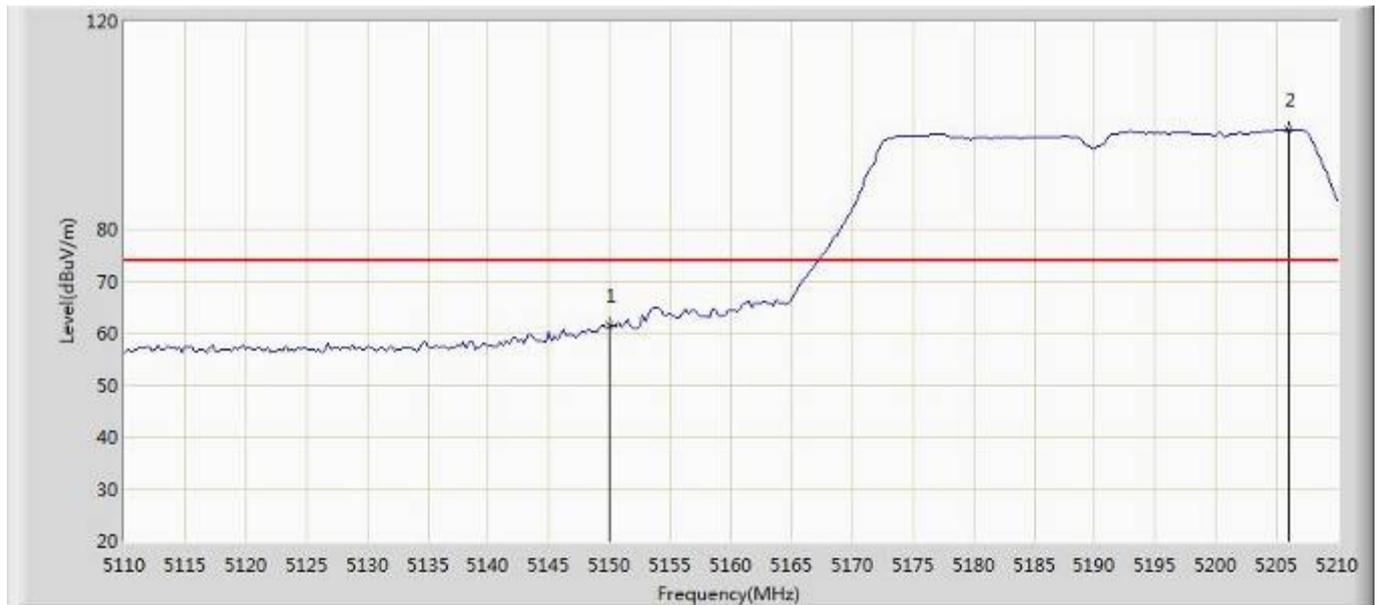

No	Mark	Frequency (MHz)	Measure Level (dBuV/m)	Reading Level (dBuV)	Over Limit (dB)	Limit (dBuV/m)	Factor (dB)	Type
1		5150.000	61.321	57.192	-12.679	74.000	4.129	PK
2	*	5206.000	99.169	94.869	N/A	N/A	4.300	PK



Site:AC102	Time: 2017/07/26 - 19:47
Limit: FCC_Part15.209_RE(3m)	Margin: 0
Probe: N/A	Polarity: Horizontal
EUT: IP CAMERA	Power: 120V/60Hz
Note: Mode:Transmit 802.11n40 at 5190MHz	

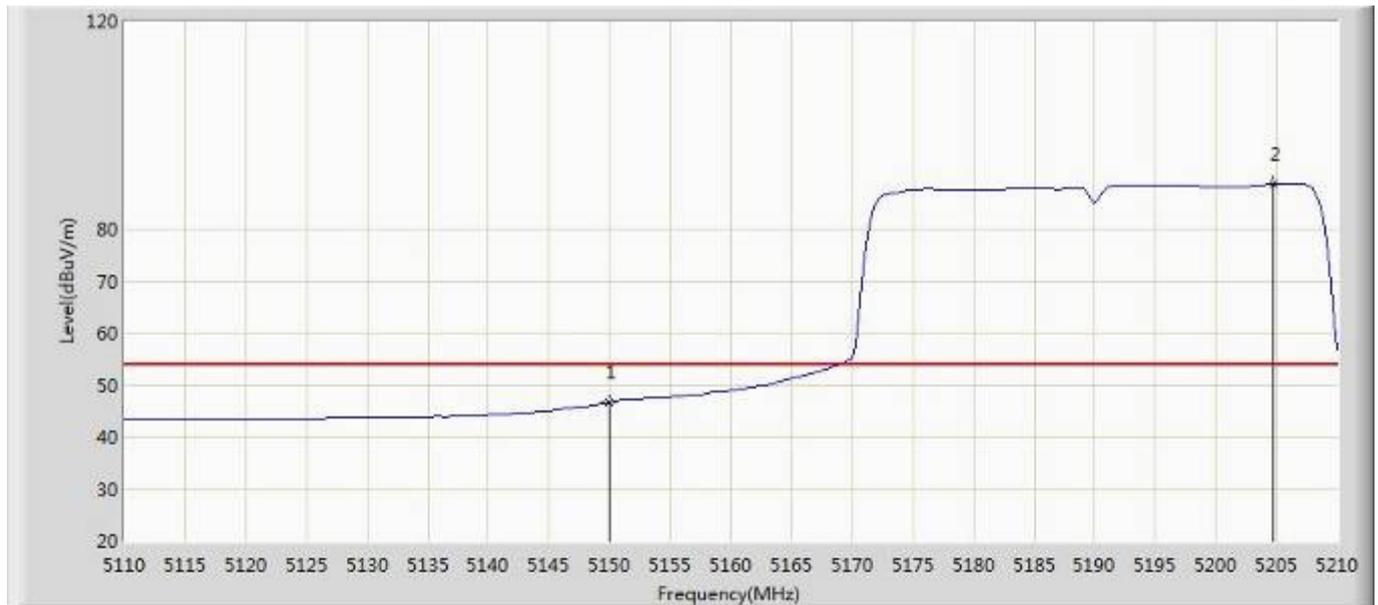

No	Mark	Frequency (MHz)	Measure Level (dBuV/m)	Reading Level (dBuV)	Over Limit (dB)	Limit (dBuV/m)	Factor (dB)	Type
1		5150.000	46.595	42.466	-7.405	54.000	4.129	AV
2	*	5204.750	88.665	84.368	N/A	N/A	4.297	AV



Site:AC102	Time: 2017/07/26 - 19:48
Limit: FCC_Part15.209_RE(3m)	Margin: 0
Probe: N/A	Polarity: Vertical
EUT: IP CAMERA	Power: 120V/60Hz
Note: Mode:Transmit 802.11n40 at 5190MHz	

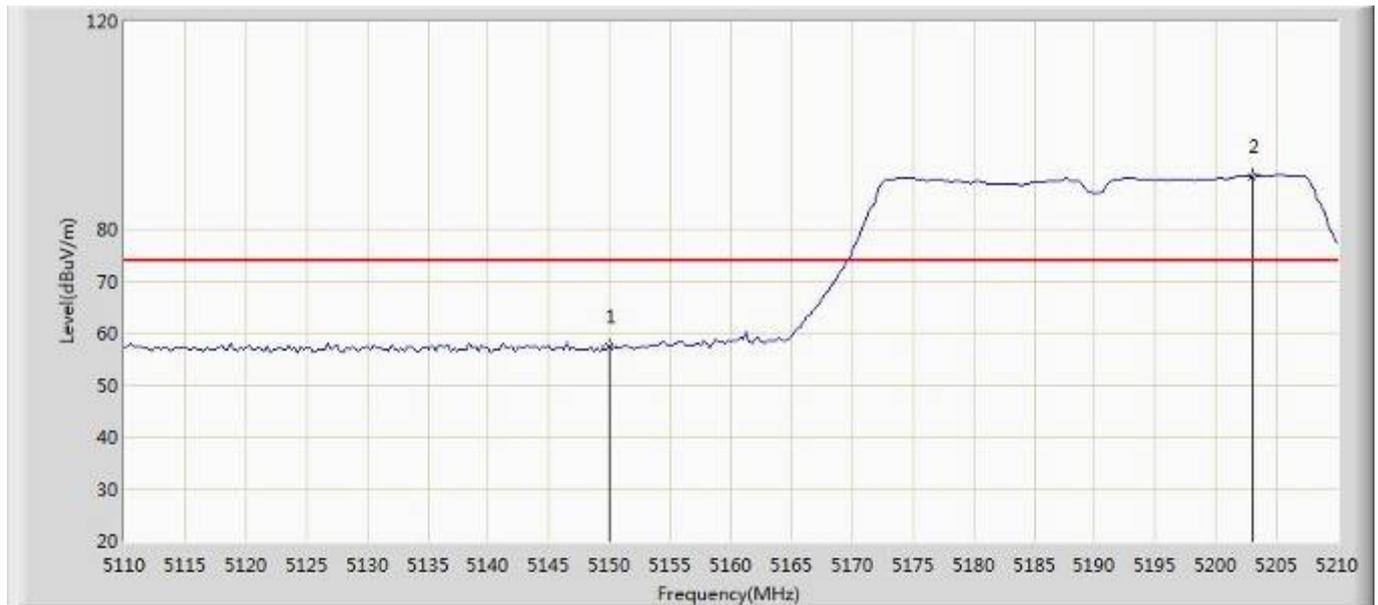

No	Mark	Frequency (MHz)	Measure Level (dBuV/m)	Reading Level (dBuV)	Over Limit (dB)	Limit (dBuV/m)	Factor (dB)	Type
1		5150.000	57.394	53.265	-16.606	74.000	4.129	PK
2	*	5203.000	90.227	85.936	N/A	N/A	4.291	PK



Site:AC102	Time: 2017/07/26 - 19:57
Limit: FCC_Part15.209_RE(3m)	Margin: 0
Probe: N/A	Polarity: Vertical
EUT: IP CAMERA	Power: 120V/60Hz
Note: Mode:Transmit 802.11n40 at 5190MHz	

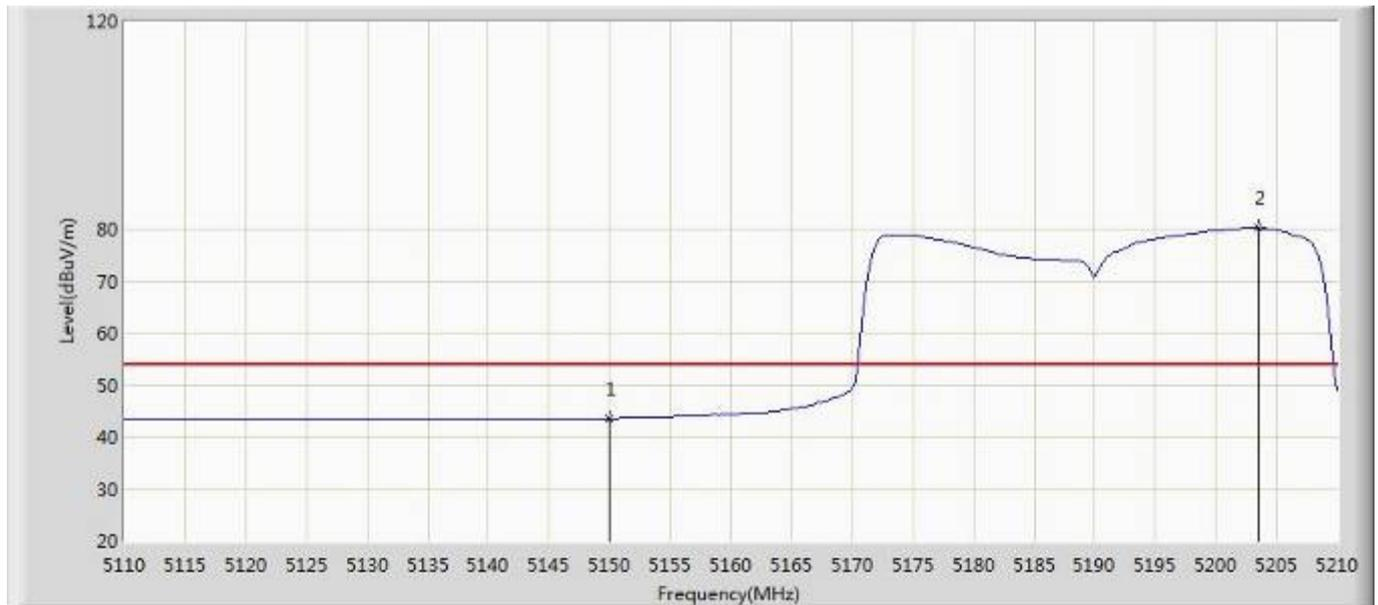

No	Mark	Frequency (MHz)	Measure Level (dBuV/m)	Reading Level (dBuV)	Over Limit (dB)	Limit (dBuV/m)	Factor (dB)	Type
1		5150.000	43.579	39.450	-10.421	54.000	4.129	AV
2	*	5203.500	80.156	75.863	N/A	N/A	4.293	AV



Site:AC102	Time: 2017/07/26 - 19:59
Limit: FCC_Part15.209_RE(3m)	Margin: 0
Probe: N/A	Polarity: Vertical
EUT: IP CAMERA	Power: 120V/60Hz
Note: Mode:Transmit 802.11n40 at 5230MHz	

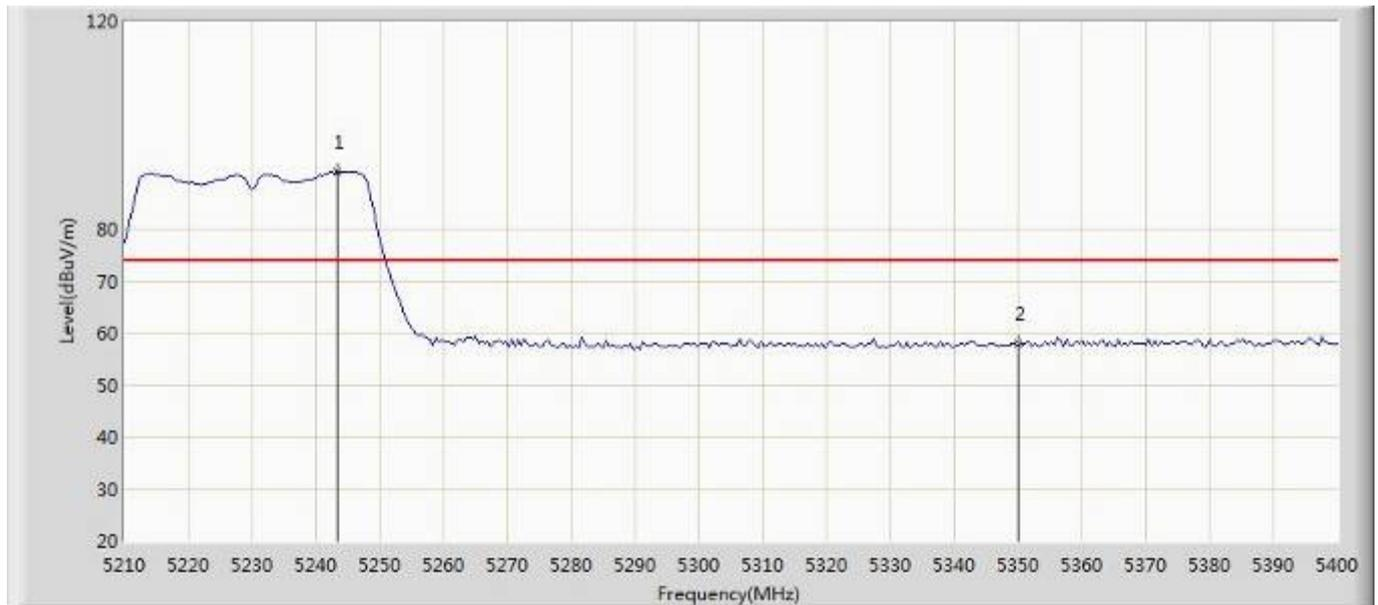

No	Mark	Frequency (MHz)	Measure Level (dBuV/m)	Reading Level (dBuV)	Over Limit (dB)	Limit (dBuV/m)	Factor (dB)	Type
1	*	5243.250	90.998	86.584	N/A	N/A	4.414	PK
2		5350.000	58.064	53.323	-15.936	74.000	4.741	PK



Site:AC102	Time: 2017/07/26 - 20:03
Limit: FCC_Part15.209_RE(3m)	Margin: 0
Probe: N/A	Polarity: Vertical
EUT: IP CAMERA	Power: 120V/60Hz
Note: Mode:Transmit 802.11n40 at 5230MHz	

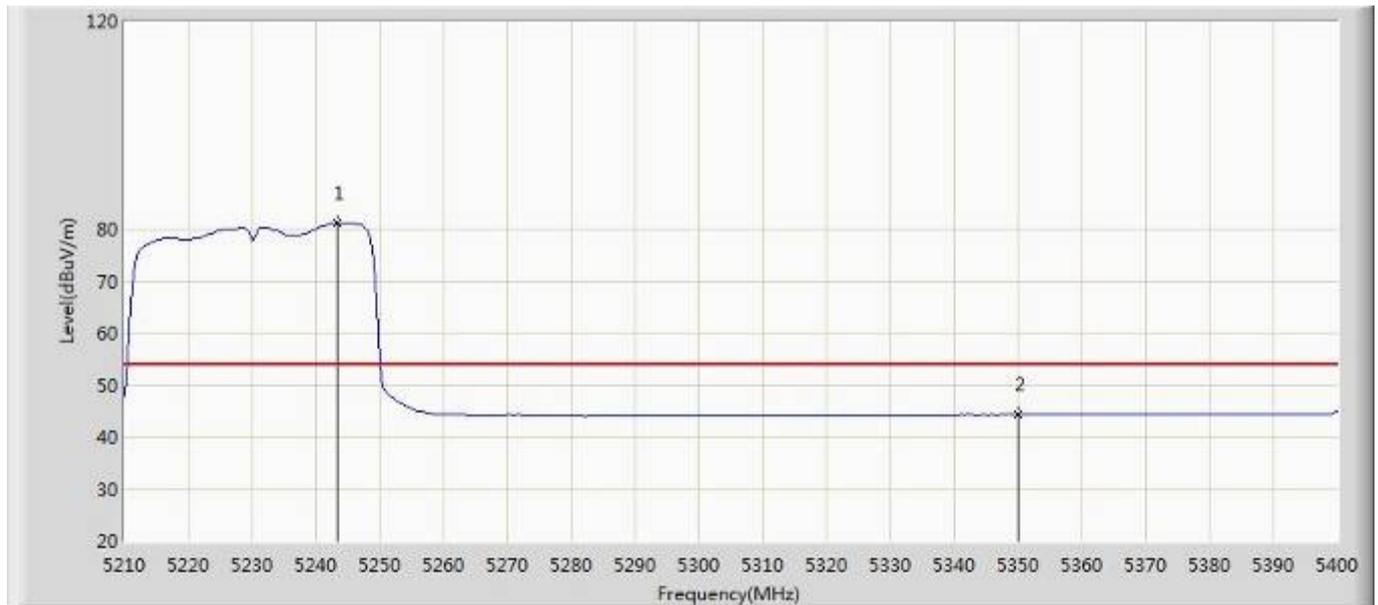

No	Mark	Frequency (MHz)	Measure Level (dBuV/m)	Reading Level (dBuV)	Over Limit (dB)	Limit (dBuV/m)	Factor (dB)	Type
1	*	5243.250	81.183	76.769	N/A	N/A	4.414	AV
2		5350.000	44.234	39.493	-9.766	54.000	4.741	AV



Site:AC102	Time: 2017/07/26 - 20:04
Limit: FCC_Part15.209_RE(3m)	Margin: 0
Probe: N/A	Polarity: Horizontal
EUT: IP CAMERA	Power: 120V/60Hz
Note: Mode:Transmit 802.11n40 at 5230MHz	

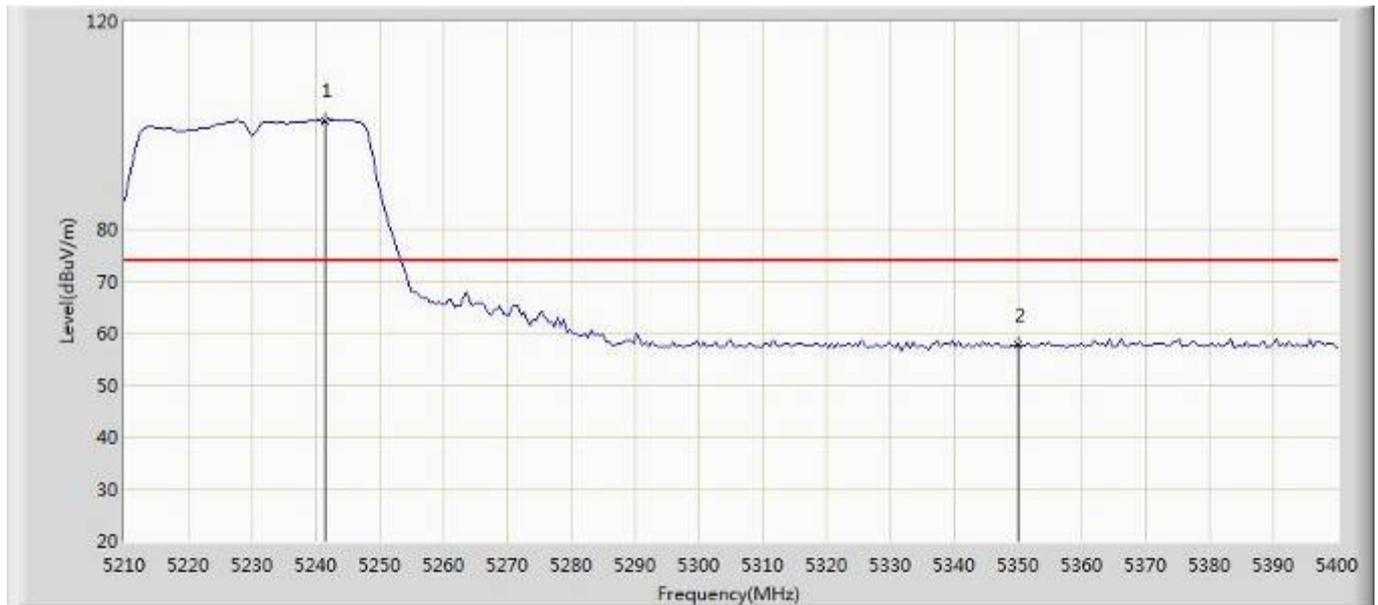

No	Mark	Frequency (MHz)	Measure Level (dBuV/m)	Reading Level (dBuV)	Over Limit (dB)	Limit (dBuV/m)	Factor (dB)	Type
1	*	5241.350	100.947	96.538	N/A	N/A	4.409	PK
2		5350.000	57.558	52.817	-16.442	74.000	4.741	PK



Site:AC102	Time: 2017/07/26 - 20:06
Limit: FCC_Part15.209_RE(3m)	Margin: 0
Probe: N/A	Polarity: Horizontal
EUT: IP CAMERA	Power: 120V/60Hz
Note: Mode:Transmit 802.11n40 at 5230MHz	

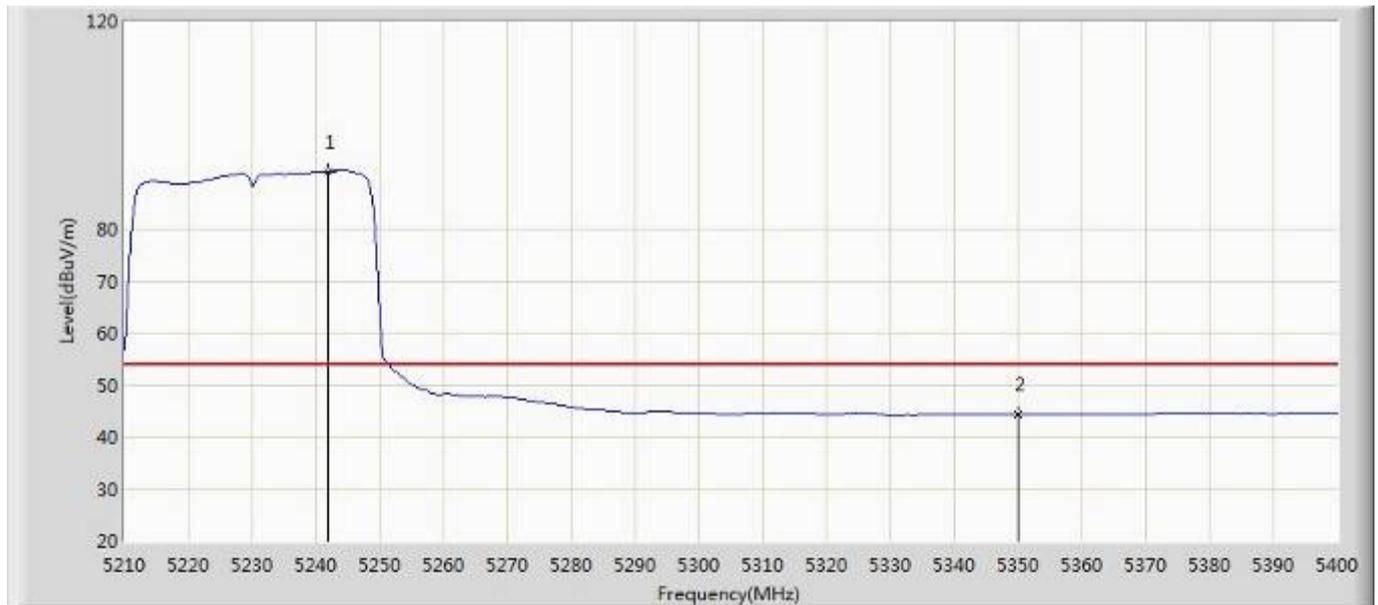

No	Mark	Frequency (MHz)	Measure Level (dBuV/m)	Reading Level (dBuV)	Over Limit (dB)	Limit (dBuV/m)	Factor (dB)	Type
1	*	5241.825	91.054	86.644	N/A	N/A	4.410	AV
2		5350.000	44.305	39.564	-9.695	54.000	4.741	AV



Site:AC102	Time: 2017/07/26 - 20:07
Limit: FCC_Part15.209_RE(3m)	Margin: 0
Probe: N/A	Polarity: Horizontal
EUT: IP CAMERA	Power: 120V/60Hz
Note: Mode:Transmit 802.11ac80 at 5210MHz	

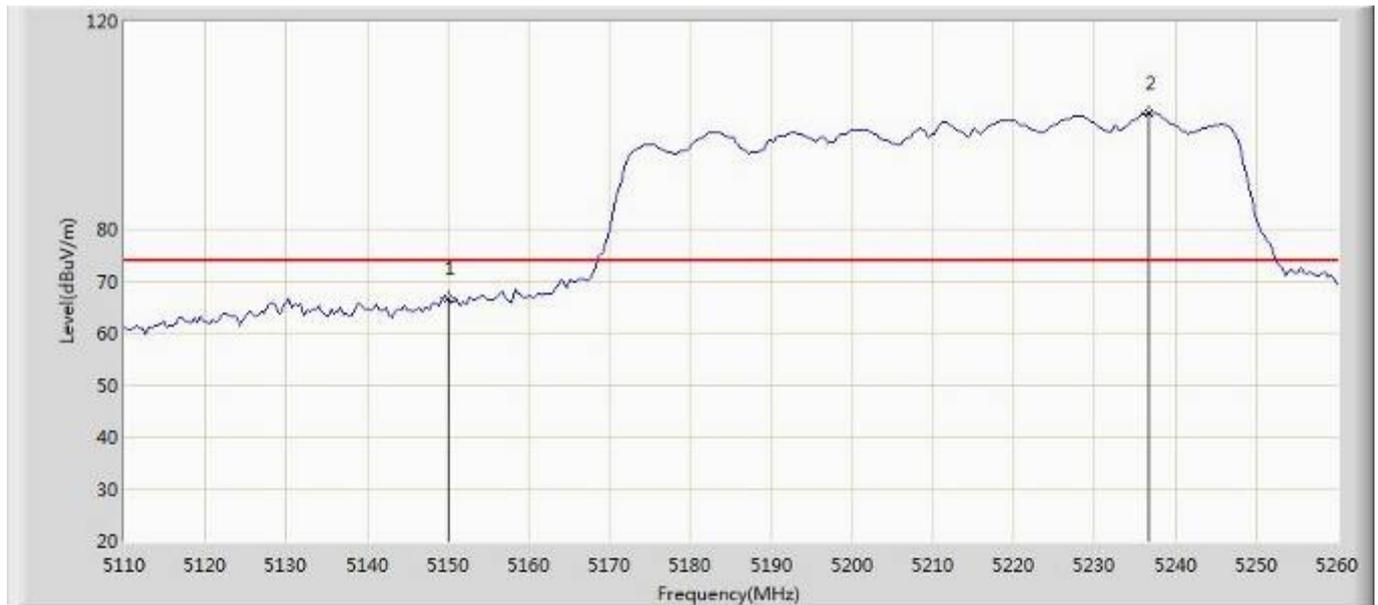

No	Mark	Frequency (MHz)	Measure Level (dBuV/m)	Reading Level (dBuV)	Over Limit (dB)	Limit (dBuV/m)	Factor (dB)	Type
1		5150.000	66.641	62.512	-7.359	74.000	4.129	PK
2	*	5236.750	102.219	97.825	N/A	N/A	4.394	PK



Site:AC102	Time: 2017/07/26 - 20:18
Limit: FCC_Part15.209_RE(3m)	Margin: 0
Probe: N/A	Polarity: Horizontal
EUT: IP CAMERA	Power: 120V/60Hz
Note: Mode:Transmit 802.11ac80 at 5210MHz	

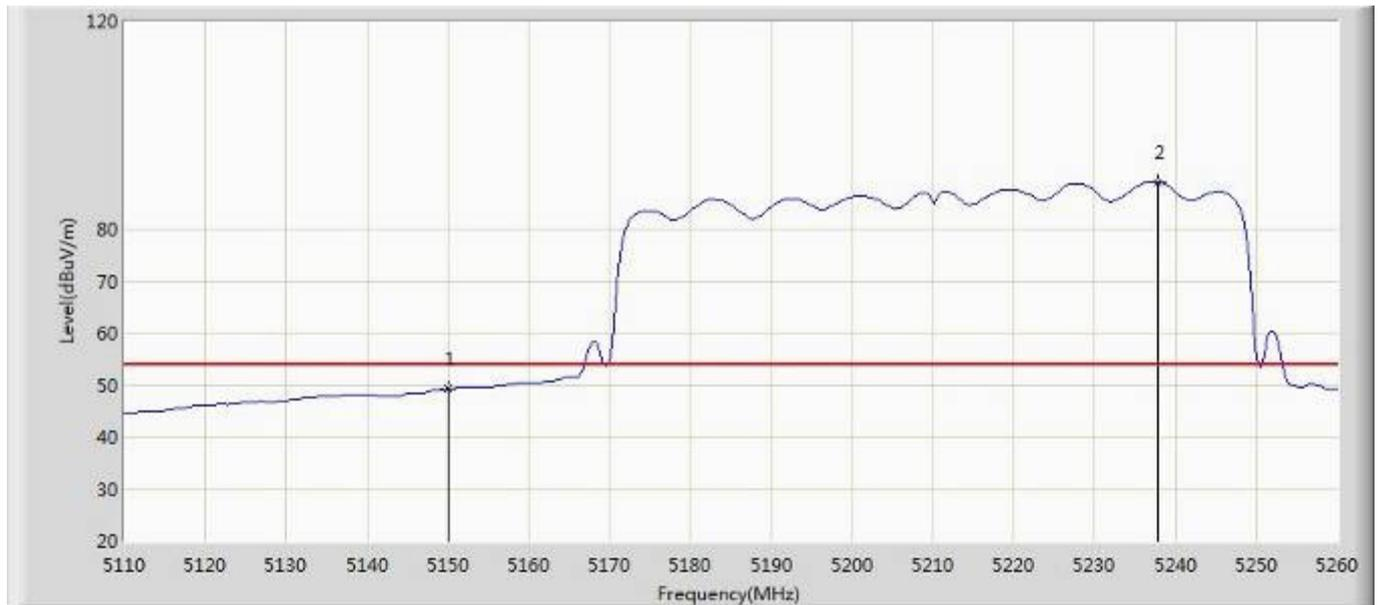

No	Mark	Frequency (MHz)	Measure Level (dBuV/m)	Reading Level (dBuV)	Over Limit (dB)	Limit (dBuV/m)	Factor (dB)	Type
1		5150.000	49.183	45.054	-4.817	54.000	4.129	AV
2	*	5237.875	89.028	84.630	N/A	N/A	4.398	AV



Site:AC102	Time: 2017/07/26 - 20:18
Limit: FCC_Part15.209_RE(3m)	Margin: 0
Probe: N/A	Polarity: Vertical
EUT: IP CAMERA	Power: 120V/60Hz
Note: Mode:Transmit 802.11ac80 at 5210MHz	



No	Mark	Frequency (MHz)	Measure Level (dBuV/m)	Reading Level (dBuV)	Over Limit (dB)	Limit (dBuV/m)	Factor (dB)	Type
1		5150.000	57.092	52.963	-16.908	74.000	4.129	PK
2	*	5237.500	87.617	83.220	N/A	N/A	4.397	PK



Site:AC102	Time: 2017/07/26 - 20:20
Limit: FCC_Part15.209_RE(3m)	Margin: 0
Probe: N/A	Polarity: Vertical
EUT: IP CAMERA	Power: 120V/60Hz
Note: Mode:Transmit 802.11ac80 at 5210MHz	

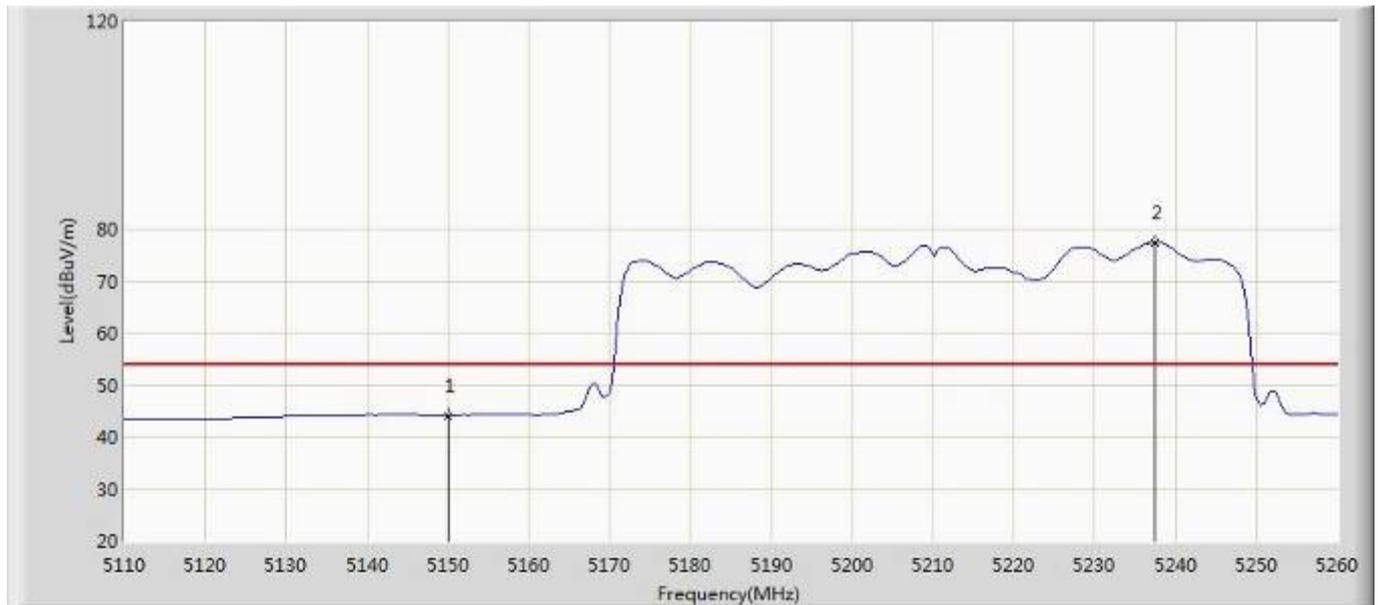

No	Mark	Frequency (MHz)	Measure Level (dBuV/m)	Reading Level (dBuV)	Over Limit (dB)	Limit (dBuV/m)	Factor (dB)	Type
1		5150.000	44.044	39.915	-9.956	54.000	4.129	AV
2	*	5237.500	77.312	72.915	N/A	N/A	4.397	AV



Site:AC102	Time: 2017/07/31 - 18:49
Limit: Bandedge-Band3	Margin: 0
Probe: N/A	Polarity: Horizontal
EUT: IP CAMERA	Power: 120V/60Hz
Note: Mode:Transmit 802.11a at 5745MHz	

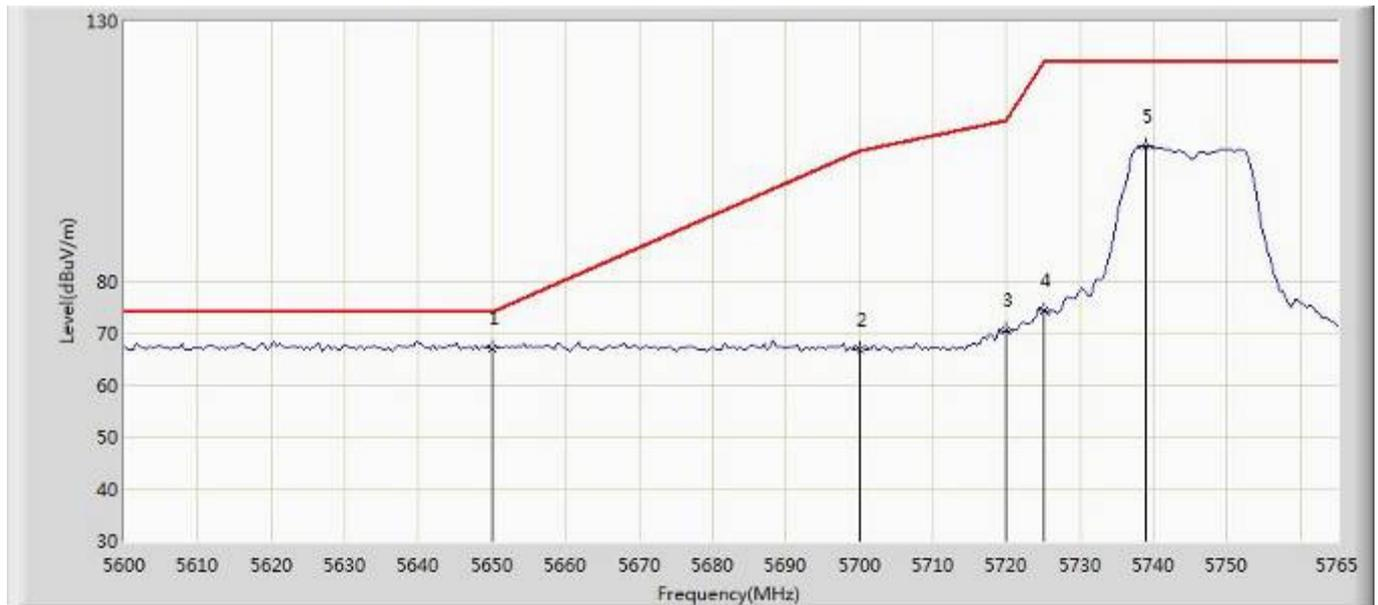

No	Mark	Frequency (MHz)	Measure Level (dBuV/m)	Reading Level (dBuV)	Over Limit (dB)	Limit (dBuV/m)	Factor (dB)	Type
1	*	5650.000	66.969	61.706	N/A	N/A	5.263	PK
2		5700.000	66.916	61.632	-38.284	105.200	5.284	PK
3		5720.000	70.686	65.393	-40.114	110.800	5.293	PK
4		5725.000	74.267	68.972	-47.933	122.200	5.295	PK
5		5739.013	105.941	100.641	-16.259	122.200	5.300	PK



Site:AC102	Time: 2017/07/31 - 19:15
Limit: Bandedge-Band3	Margin: 0
Probe: N/A	Polarity: Vertical
EUT: IP CAMERA	Power: 120V/60Hz
Note: Mode:Transmit 802.11a at 5745MHz	

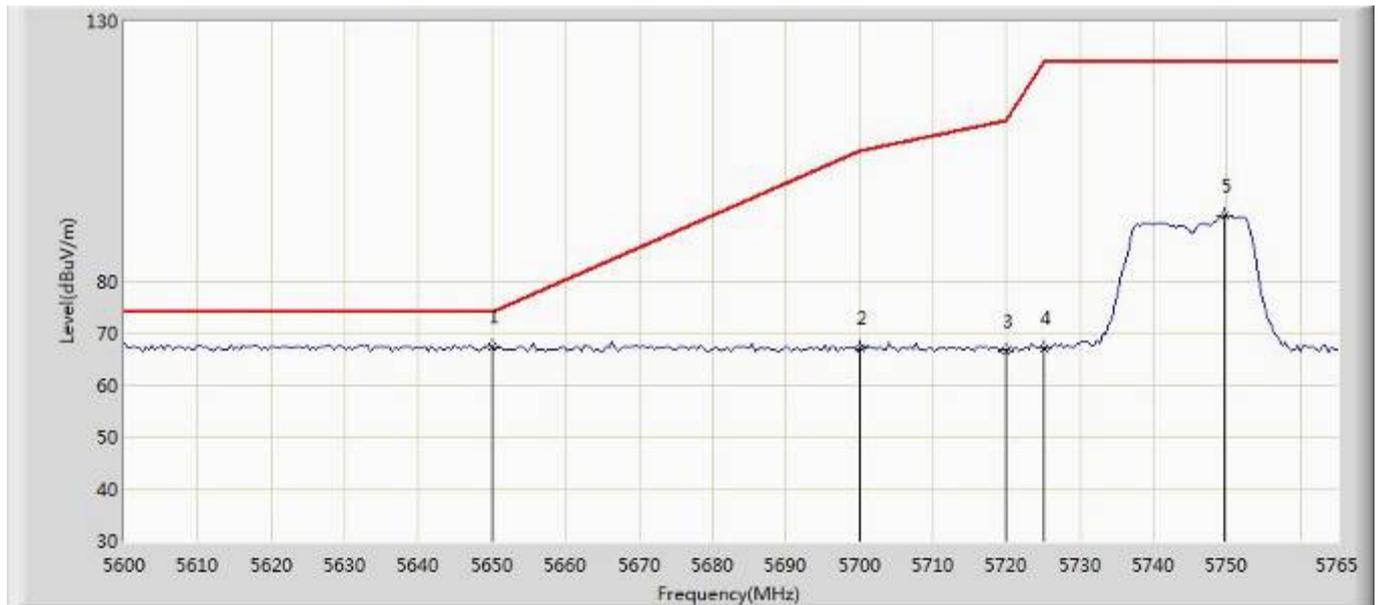

No	Mark	Frequency (MHz)	Measure Level (dBuV/m)	Reading Level (dBuV)	Over Limit (dB)	Limit (dBuV/m)	Factor (dB)	Type
1	*	5650.000	67.483	62.220	N/A	N/A	5.263	PK
2		5700.000	67.014	61.730	-38.186	105.200	5.284	PK
3		5720.000	66.610	61.317	-44.190	110.800	5.293	PK
4		5725.000	67.178	61.883	-55.022	122.200	5.295	PK
5		5749.737	92.612	87.307	-29.588	122.200	5.305	PK



Site:AC102	Time: 2017/07/31 - 19:25
Limit: Bandedge-Band3	Margin: 0
Probe: N/A	Polarity: Vertical
EUT: IP CAMERA	Power: 120V/60Hz
Note: Mode:Transmit 802.11a at 5825MHz	

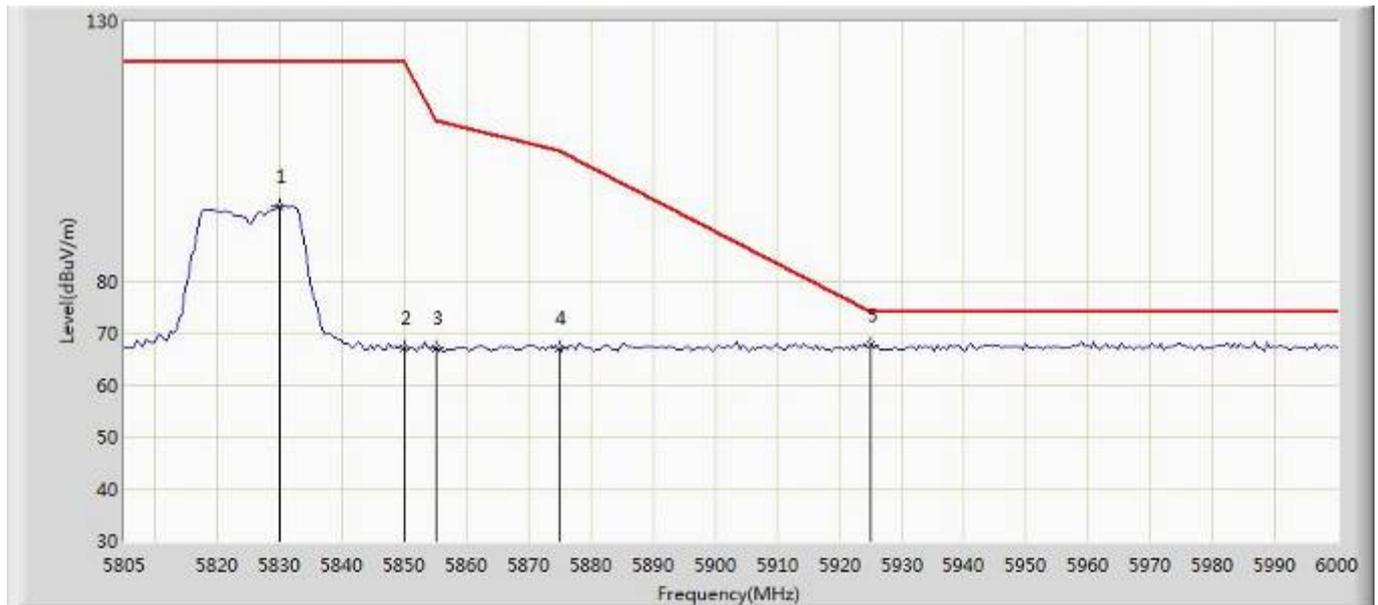

No	Mark	Frequency (MHz)	Measure Level (dBuV/m)	Reading Level (dBuV)	Over Limit (dB)	Limit (dBuV/m)	Factor (dB)	Type
1		5829.862	94.260	88.921	-27.940	122.200	5.339	PK
2		5850.000	67.081	61.734	-55.119	122.200	5.347	PK
3		5855.000	67.047	61.698	-43.753	110.800	5.349	PK
4		5875.000	66.975	61.618	-38.225	105.200	5.357	PK
5	*	5925.000	67.716	62.337	N/A	N/A	5.379	PK



Site:AC102	Time: 2017/07/31 - 19:27
Limit: Bandedge-Band3	Margin: 0
Probe: N/A	Polarity: Horizontal
EUT: IP CAMERA	Power: 120V/60Hz
Note: Mode:Transmit 802.11a at 5825MHz	

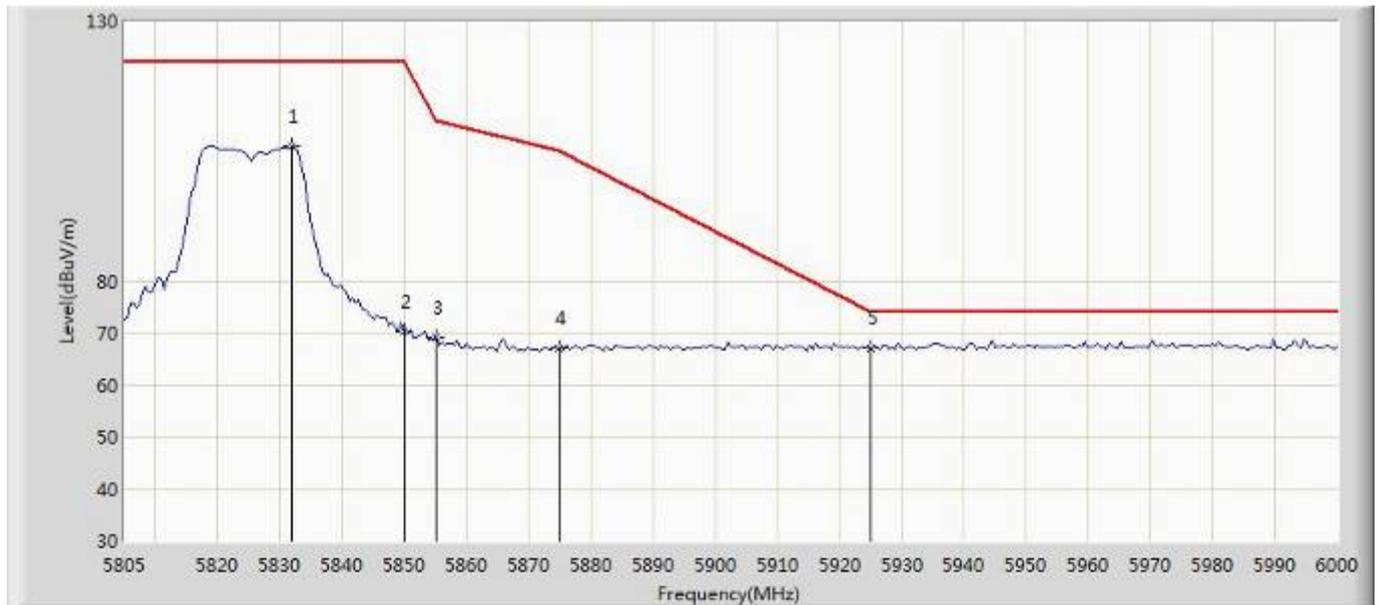

No	Mark	Frequency (MHz)	Measure Level (dBuV/m)	Reading Level (dBuV)	Over Limit (dB)	Limit (dBuV/m)	Factor (dB)	Type
1		5831.812	105.836	100.496	-16.364	122.200	5.340	PK
2		5850.000	70.220	64.873	-51.980	122.200	5.347	PK
3		5855.000	69.001	63.652	-41.799	110.800	5.349	PK
4		5875.000	67.079	61.722	-38.121	105.200	5.357	PK
5	*	5925.000	67.182	61.803	N/A	N/A	5.379	PK



Site:AC102	Time: 2017/07/31 - 19:31
Limit: Bandedge-Band3	Margin: 0
Probe: N/A	Polarity: Horizontal
EUT: IP CAMERA	Power: 120V/60Hz
Note: Mode:Transmit 802.11n20 at 5745MHz	

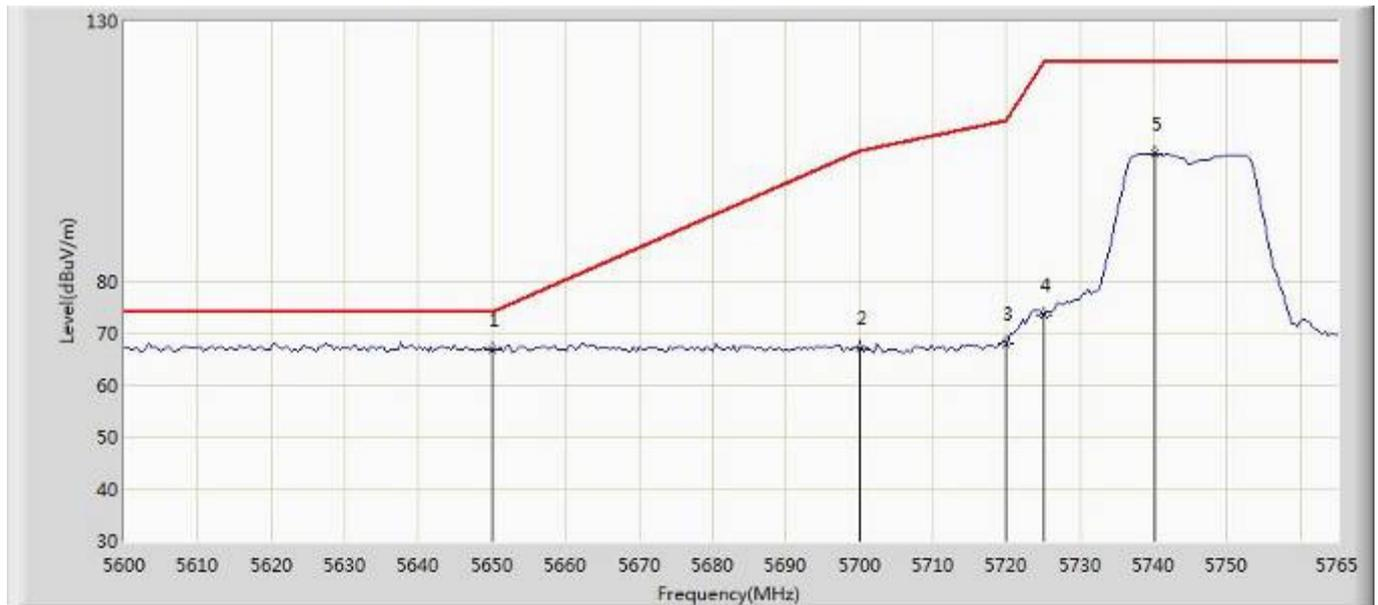

No	Mark	Frequency (MHz)	Measure Level (dBuV/m)	Reading Level (dBuV)	Over Limit (dB)	Limit (dBuV/m)	Factor (dB)	Type
1	*	5650.000	66.749	61.486	N/A	N/A	5.263	PK
2		5700.000	66.992	61.708	-38.208	105.200	5.284	PK
3		5720.000	68.053	62.760	-42.747	110.800	5.293	PK
4		5725.000	73.594	68.299	-48.606	122.200	5.295	PK
5		5740.250	104.510	99.209	-17.690	122.200	5.301	PK



Site:AC102	Time: 2017/07/31 - 19:33
Limit: Bandedge-Band3	Margin: 0
Probe: N/A	Polarity: Vertical
EUT: IP CAMERA	Power: 120V/60Hz
Note: Mode:Transmit 802.11n20 at 5745MHz	

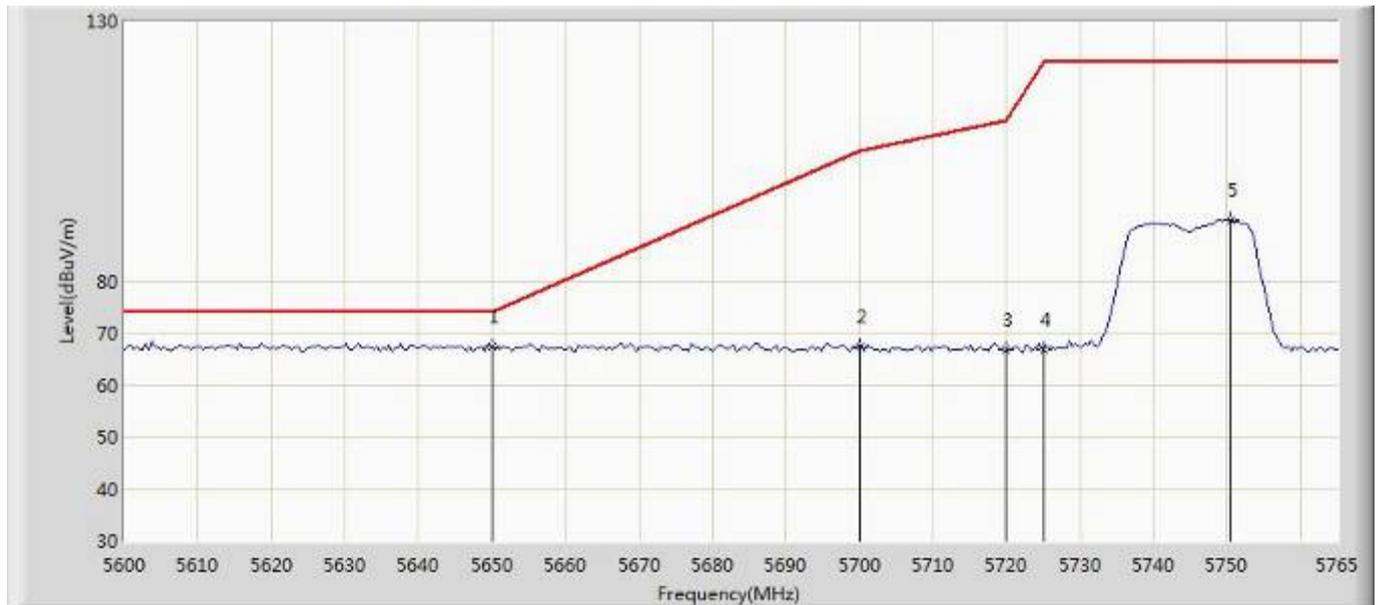

No	Mark	Frequency (MHz)	Measure Level (dBuV/m)	Reading Level (dBuV)	Over Limit (dB)	Limit (dBuV/m)	Factor (dB)	Type
1	*	5650.000	67.508	62.245	N/A	N/A	5.263	PK
2		5700.000	67.516	62.232	-37.684	105.200	5.284	PK
3		5720.000	66.723	61.430	-44.077	110.800	5.293	PK
4		5725.000	66.735	61.440	-55.465	122.200	5.295	PK
5		5750.562	91.791	86.486	-30.409	122.200	5.305	PK



Site:AC102	Time: 2017/07/31 - 19:37
Limit: Bandedge-Band3	Margin: 0
Probe: N/A	Polarity: Vertical
EUT: IP CAMERA	Power: 120V/60Hz
Note: Mode:Transmit 802.11n20 at 5825MHz	

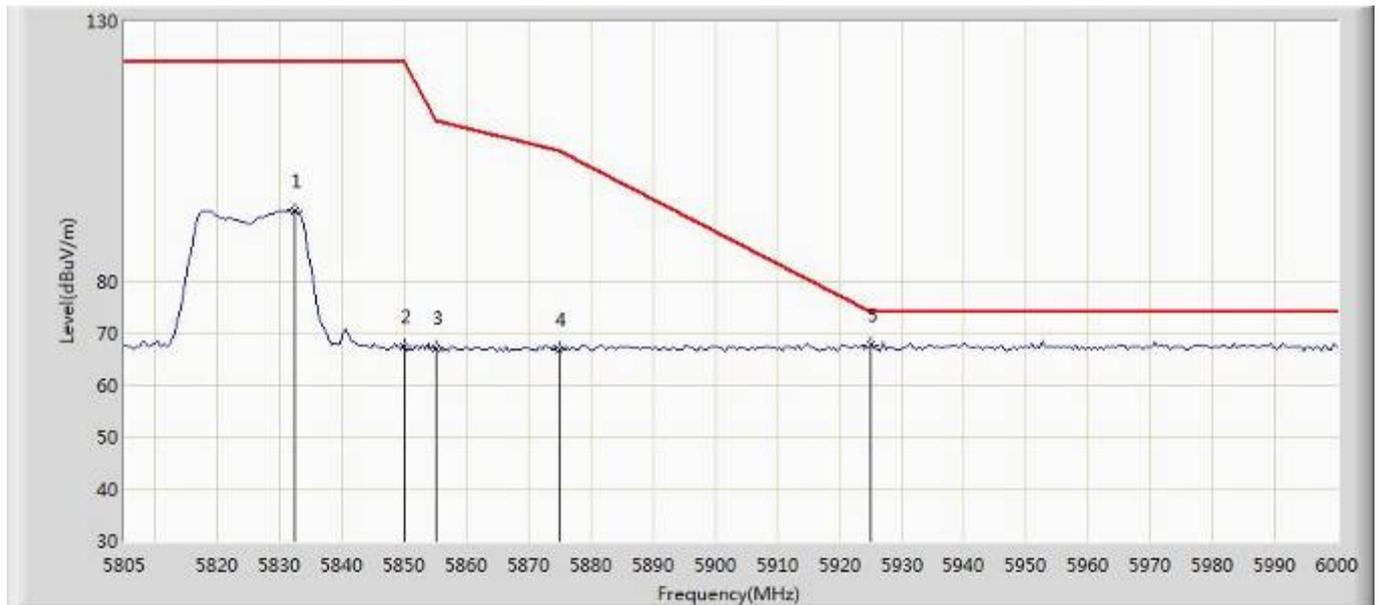

No	Mark	Frequency (MHz)	Measure Level (dBuV/m)	Reading Level (dBuV)	Over Limit (dB)	Limit (dBuV/m)	Factor (dB)	Type
1		5832.300	93.608	88.268	-28.592	122.200	5.340	PK
2		5850.000	67.385	62.038	-54.815	122.200	5.347	PK
3		5855.000	67.154	61.805	-43.646	110.800	5.349	PK
4		5875.000	66.721	61.364	-38.479	105.200	5.357	PK
5	*	5925.000	67.751	62.372	N/A	N/A	5.379	PK



Site:AC102	Time: 2017/07/31 - 19:40
Limit: Bandedge-Band3	Margin: 0
Probe: N/A	Polarity: Horizontal
EUT: IP CAMERA	Power: 120V/60Hz
Note: Mode:Transmit 802.11n20 at 5825MHz	

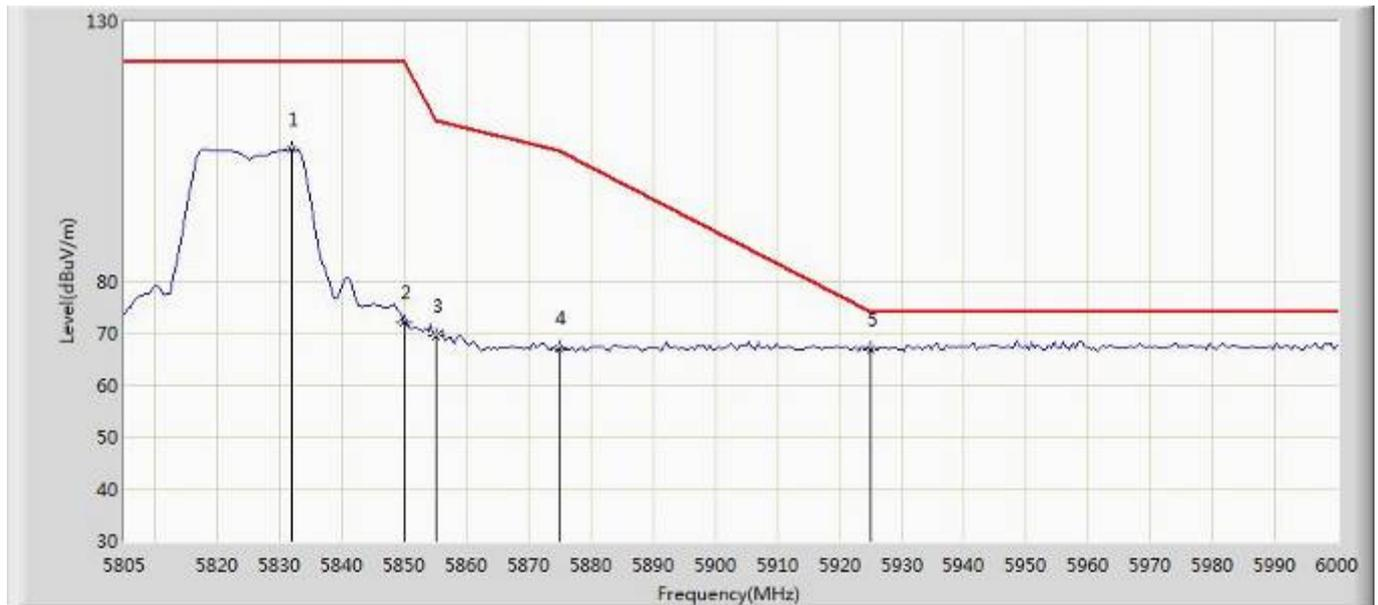

No	Mark	Frequency (MHz)	Measure Level (dBuV/m)	Reading Level (dBuV)	Over Limit (dB)	Limit (dBuV/m)	Factor (dB)	Type
1		5831.812	105.386	100.046	-16.814	122.200	5.340	PK
2		5850.000	72.012	66.665	-50.188	122.200	5.347	PK
3		5855.000	69.561	64.212	-41.239	110.800	5.349	PK
4		5875.000	67.026	61.669	-38.174	105.200	5.357	PK
5	*	5925.000	66.769	61.390	N/A	N/A	5.379	PK



Site:AC102	Time: 2017/07/31 - 19:42
Limit: Bandedge-Band3	Margin: 0
Probe: N/A	Polarity: Horizontal
EUT: IP CAMERA	Power: 120V/60Hz
Note: Mode:Transmit 802.11n40 at 5755MHz	

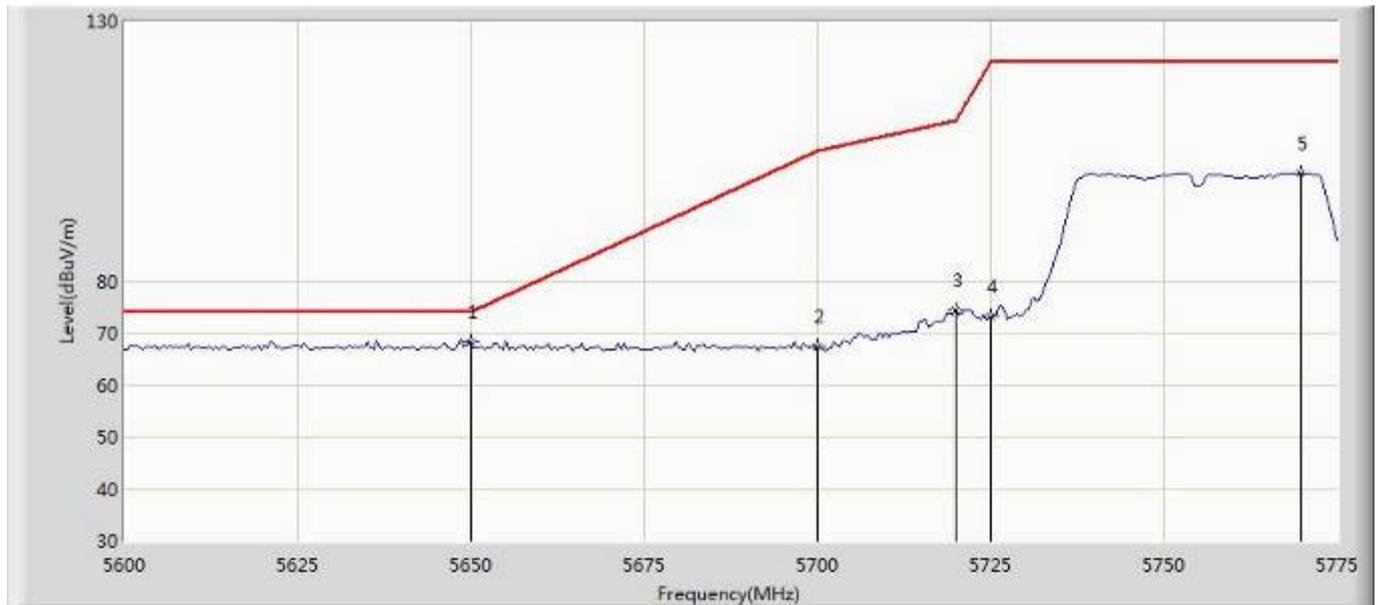

No	Mark	Frequency (MHz)	Measure Level (dBuV/m)	Reading Level (dBuV)	Over Limit (dB)	Limit (dBuV/m)	Factor (dB)	Type
1	*	5650.000	68.159	62.896	N/A	N/A	5.263	PK
2		5700.000	67.358	62.074	-37.842	105.200	5.284	PK
3		5720.000	74.232	68.939	-36.568	110.800	5.293	PK
4		5725.000	73.188	67.893	-49.012	122.200	5.295	PK
5		5769.750	100.657	95.344	-21.543	122.200	5.313	PK



Site:AC102	Time: 2017/07/31 - 19:46
Limit: Bandedge-Band3	Margin: 0
Probe: N/A	Polarity: Vertical
EUT: IP CAMERA	Power: 120V/60Hz
Note: Mode:Transmit 802.11n40 at 5755MHz	

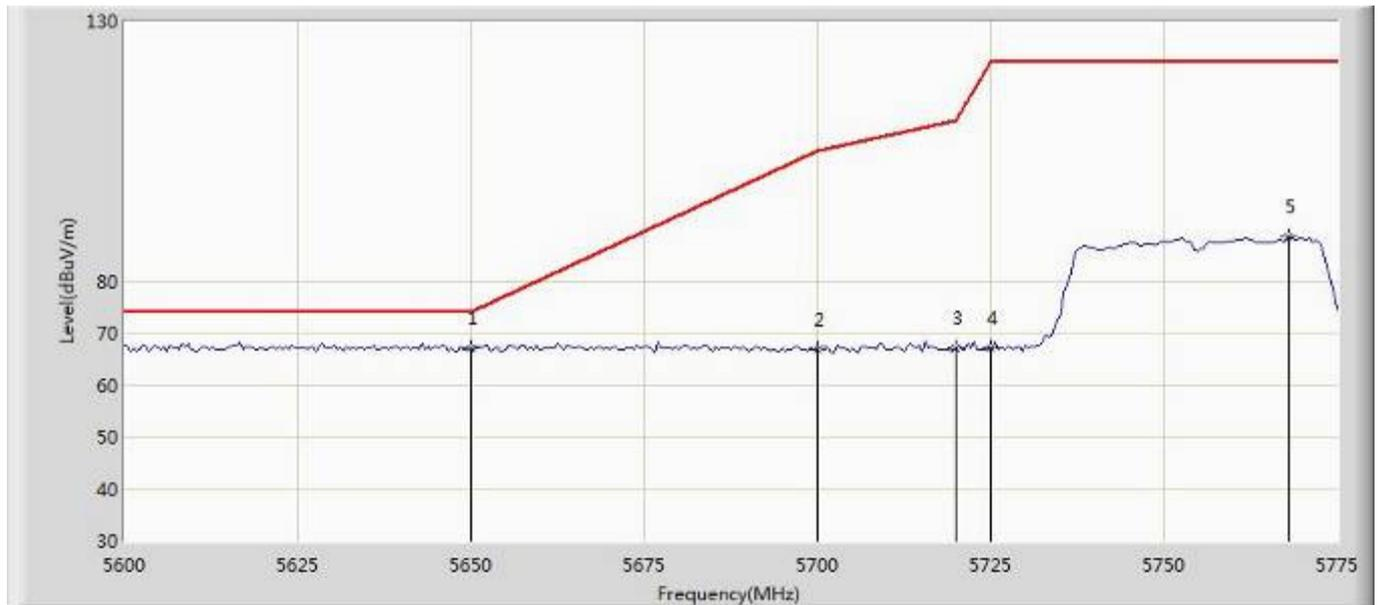

No	Mark	Frequency (MHz)	Measure Level (dBuV/m)	Reading Level (dBuV)	Over Limit (dB)	Limit (dBuV/m)	Factor (dB)	Type
1	*	5650.000	67.067	61.804	N/A	N/A	5.263	PK
2		5700.000	66.845	61.561	-38.355	105.200	5.284	PK
3		5720.000	67.112	61.819	-43.688	110.800	5.293	PK
4		5725.000	67.179	61.884	-55.021	122.200	5.295	PK
5		5768.000	88.415	83.103	-33.785	122.200	5.312	PK



Site:AC102	Time: 2017/07/31 - 19:48
Limit: Bandedge-Band3	Margin: 0
Probe: N/A	Polarity: Vertical
EUT: IP CAMERA	Power: 120V/60Hz
Note: Mode:Transmit 802.11n40 at 5795MHz	

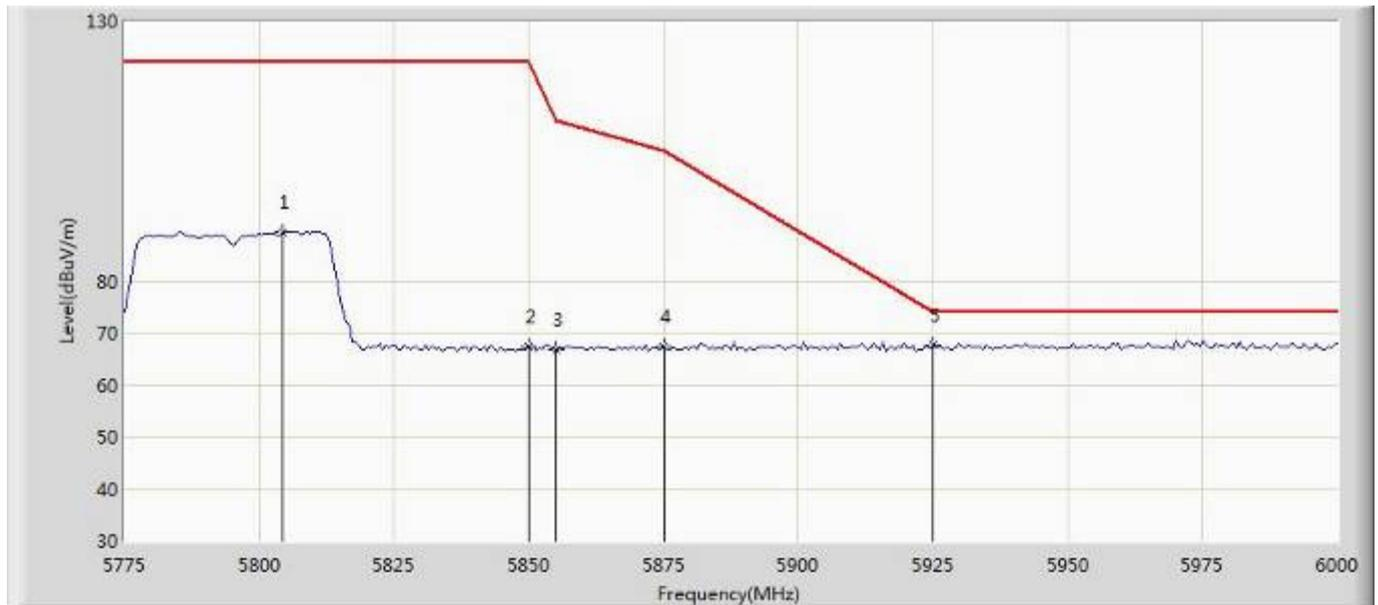

No	Mark	Frequency (MHz)	Measure Level (dBuV/m)	Reading Level (dBuV)	Over Limit (dB)	Limit (dBuV/m)	Factor (dB)	Type
1		5804.250	89.332	84.004	-32.868	122.200	5.328	PK
2		5850.000	67.294	61.947	-54.906	122.200	5.347	PK
3		5855.000	66.832	61.483	-43.968	110.800	5.349	PK
4		5875.000	67.282	61.925	-37.918	105.200	5.357	PK
5	*	5925.000	67.584	62.205	N/A	N/A	5.379	PK



Site:AC102	Time: 2017/07/31 - 19:51
Limit: Bandedge-Band3	Margin: 0
Probe: N/A	Polarity: Horizontal
EUT: IP CAMERA	Power: 120V/60Hz
Note: Mode:Transmit 802.11n40 at 5795MHz	

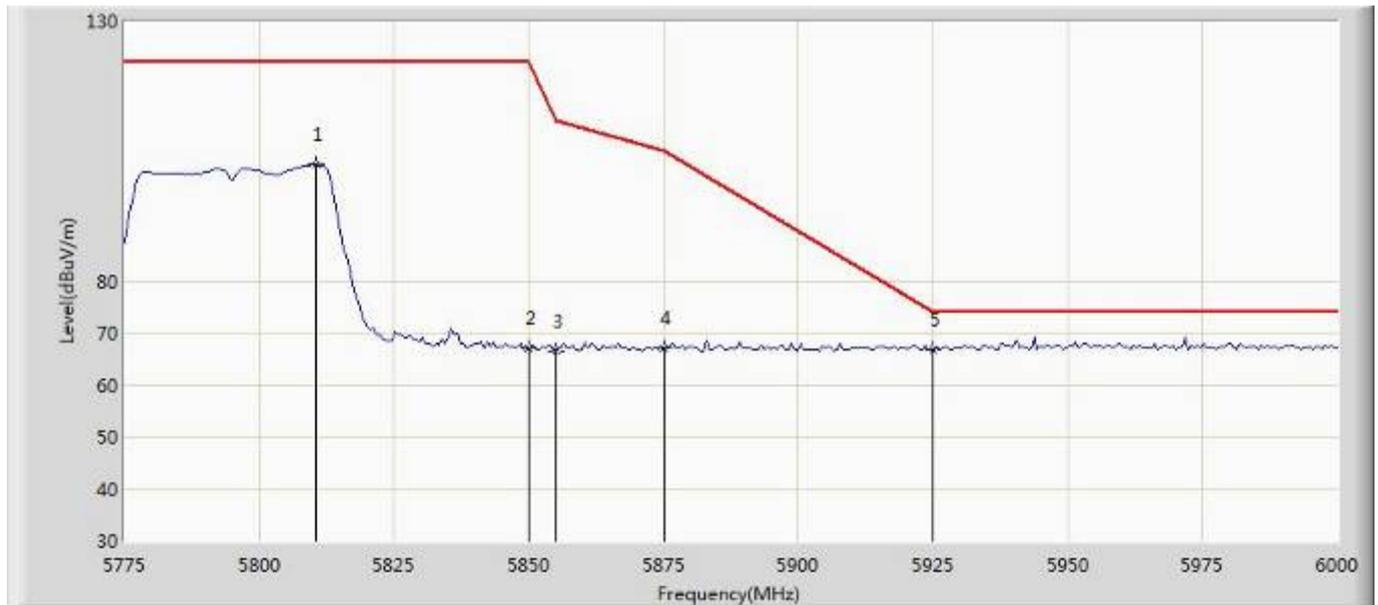

No	Mark	Frequency (MHz)	Measure Level (dBuV/m)	Reading Level (dBuV)	Over Limit (dB)	Limit (dBuV/m)	Factor (dB)	Type
1		5810.437	102.421	97.090	-19.779	122.200	5.331	PK
2		5850.000	66.976	61.629	-55.224	122.200	5.347	PK
3		5855.000	66.510	61.161	-44.290	110.800	5.349	PK
4		5875.000	67.195	61.838	-38.005	105.200	5.357	PK
5	*	5925.000	66.847	61.468	N/A	N/A	5.379	PK



Site:AC102	Time: 2017/07/31 - 19:55
Limit: Bandedge-Band3	Margin: 0
Probe: N/A	Polarity: Horizontal
EUT: IP CAMERA	Power: 120V/60Hz
Note: Mode:Transmit 802.11ac80 at 5775MHz	

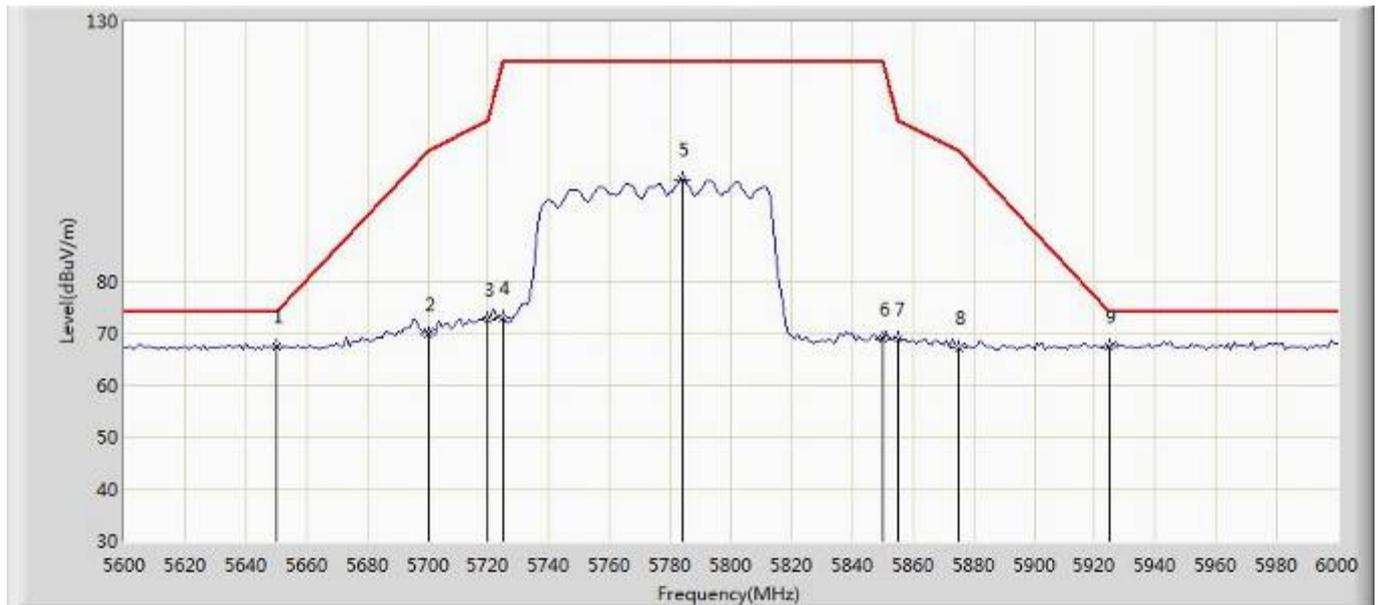

No	Mark	Frequency (MHz)	Measure Level (dBuV/m)	Reading Level (dBuV)	Over Limit (dB)	Limit (dBuV/m)	Factor (dB)	Type
1	*	5650.000	67.458	62.195	N/A	N/A	5.263	PK
2		5700.000	69.813	64.529	-35.387	105.200	5.284	PK
3		5720.000	72.675	67.382	-38.125	110.800	5.293	PK
4		5725.000	72.827	67.532	-49.373	122.200	5.295	PK
5		5784.000	99.516	94.197	-22.684	122.200	5.319	PK
6		5850.000	68.972	63.625	-53.228	122.200	5.347	PK
7		5855.000	68.731	63.382	-42.069	110.800	5.349	PK
8		5875.000	67.044	61.687	-38.156	105.200	5.357	PK
9		5925.000	67.284	61.905	-6.716	74.000	5.379	PK



Site:AC102	Time: 2017/07/31 - 19:59
Limit: Bandedge-Band3	Margin: 0
Probe: N/A	Polarity: Vertical
EUT: IP CAMERA	Power: 120V/60Hz
Note: Mode:Transmit 802.11ac80 at 5775MHz	

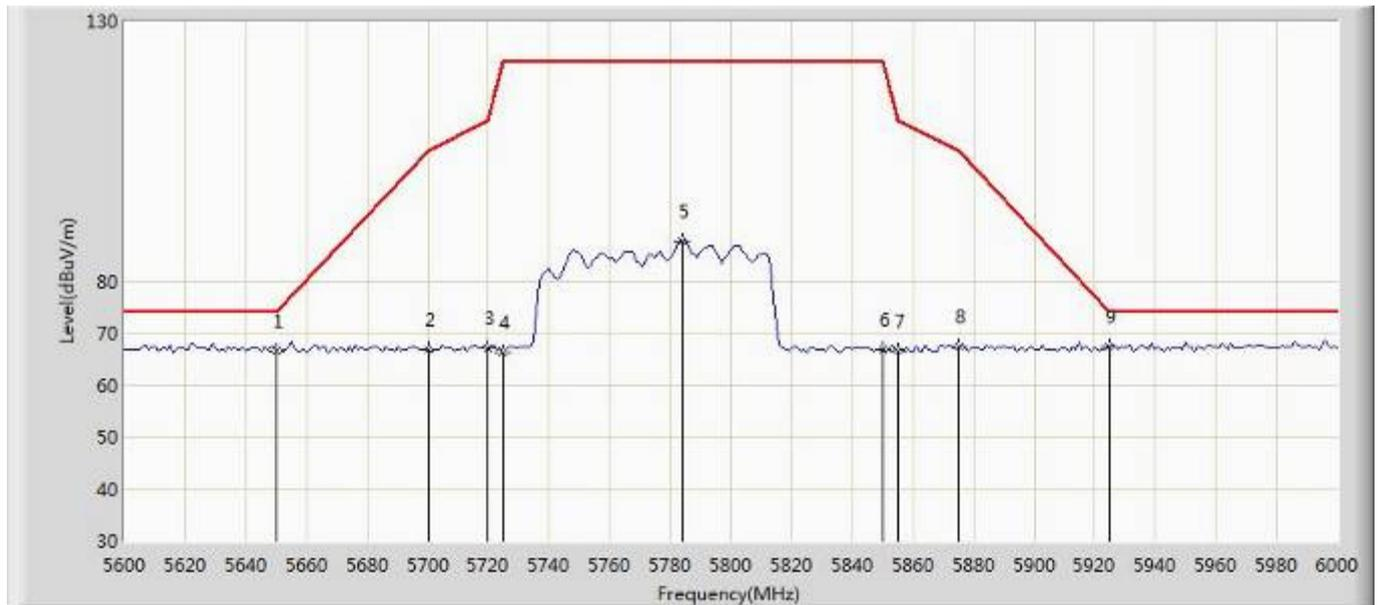

No	Mark	Frequency (MHz)	Measure Level (dBuV/m)	Reading Level (dBuV)	Over Limit (dB)	Limit (dBuV/m)	Factor (dB)	Type
1		5650.000	66.510	61.247	-7.490	74.000	5.263	PK
2		5700.000	66.697	61.413	-38.503	105.200	5.284	PK
3		5720.000	67.021	61.728	-43.779	110.800	5.293	PK
4		5725.000	66.352	61.057	-55.848	122.200	5.295	PK
5		5784.000	87.804	82.485	-34.396	122.200	5.319	PK
6		5850.000	66.866	61.519	-55.334	122.200	5.347	PK
7		5855.000	66.601	61.252	-44.199	110.800	5.349	PK
8		5875.000	67.309	61.952	-37.891	105.200	5.357	PK
9	*	5925.000	67.289	61.910	N/A	N/A	5.379	PK



10. Frequency Stability

10.1 Test Limit

According to FCC Part 15.407 – Section (g), manufactures of U-NII devices are responsible for ensuring frequency stability such that an emission is maintained within the band of operation under all conditions of normal operation as specified in the user's manual.

10.2 Test Standard

ANSI C63.10-2013 – Section 6.8

10.3 Test Procedures

Frequency Stability Under Temperature Variations:

The equipment under test was connected to an external AC or DC power supply and input rated voltage. RF output was connected to a frequency counter or spectrum analyzer via feed through attenuators. The EUT was placed inside the temperature chamber. Set the spectrum analyzer RBW low enough to obtain the desired frequency resolution and measure EUT 20°C operating frequency as reference frequency. Turn EUT off and set the chamber temperature to highest. After the temperature stabilized for approximately 30 minutes recorded the frequency. Repeat step measure with 10°C decreased per stage until the lowest temperature reached.

Frequency Stability Under Voltage Variations:

Set chamber temperature to 20°C. Use a variable AC power supply / DC power source to power the EUT and set the voltage to rated voltage. Set the spectrum analyzer RBW low enough to obtain the desired frequency resolution and recorded the frequency.

Reduce the input voltage to specify extreme voltage variation ($\pm 15\%$) and endpoint, record the maximum frequency change.



10.4 Test Setup

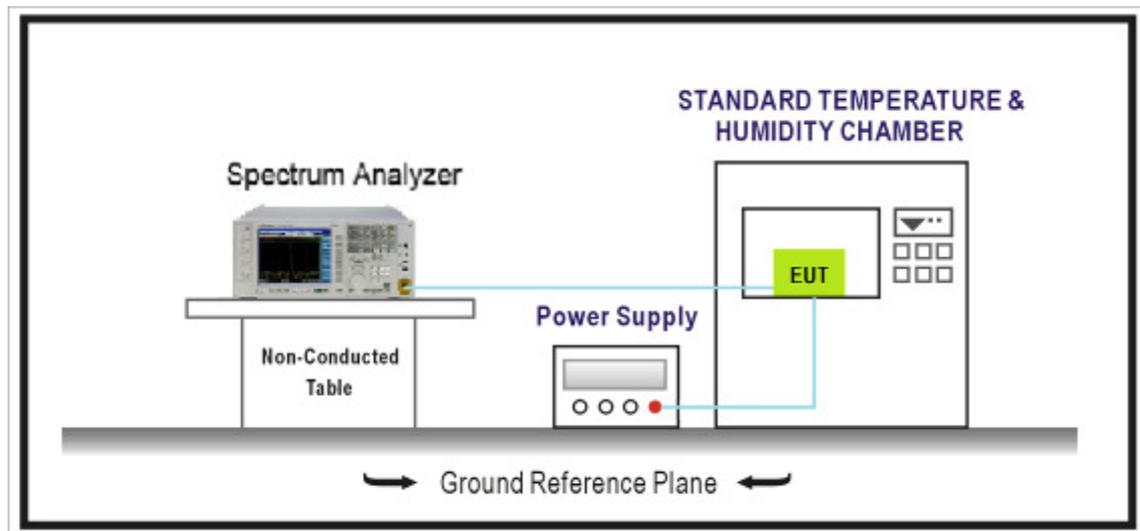

**10.5 Test Result and Data**

Product	IP CAMERA
Test Item	Frequency Stability
Test Mode	Carrier Transmit

Operating Frequency	Temp (°C)	Voltage (AC)	Frequency Tolerance (ppm)			
			0 minutes		2 minutes	
			Operation Frequency(MHz)	Measure Level(ppm)	Operation Frequency(MHz)	Measure Level(ppm)
36	0	102	5180.0161	3.11	5180.0188	3.63
		120	5180.0123	2.37	5180.0150	2.90
		138	5180.0147	2.84	5180.0161	3.11
	10	102	5180.0132	2.55	5180.0170	3.28
		120	5180.0160	3.09	5180.0119	2.30
		138	5180.0148	2.86	5180.0119	2.30
	20	102	5180.0105	2.03	5180.0183	3.53
		120	5180.0119	2.30	5180.0147	2.84
		138	5180.0186	3.59	5180.0141	2.72
	30	102	5180.0169	3.26	5180.0164	3.17
		120	5180.0164	3.17	5180.0137	2.64
		138	5180.0179	3.46	5180.0104	2.01
40	102	5180.0121	2.34	5180.0107	2.07	
	120	5180.0154	2.97	5180.0162	3.13	
	138	5180.0185	3.57	5180.0139	2.68	
44	0	102	5220.0137	2.62	5220.0173	3.31
		120	5220.0161	3.08	5220.0130	2.49
		138	5220.0161	3.08	5220.0154	2.95
	10	102	5220.0186	3.56	5220.0131	2.51
		120	5220.0183	3.51	5220.0181	3.47
		138	5220.0113	2.16	5220.0148	2.84
	20	102	5220.0164	3.14	5220.0167	3.20
		120	5220.0129	2.47	5220.0170	3.26
		138	5220.0109	2.09	5220.0196	3.75
	30	102	5220.0163	3.12	5220.0115	2.20



		120	5220.0116	2.22	5220.0183	3.51	
		138	5220.0148	2.84	5220.0133	2.55	
	40	102	5220.0176	3.37	5220.0101	1.93	
		120	5220.0155	2.97	5220.0200	3.83	
		138	5220.0127	2.43	5220.0154	2.95	
48	0	102	5240.0182	3.47	5240.0148	2.82	
		120	5240.0147	2.81	5240.0150	2.86	
		138	5240.0192	3.66	5240.0152	2.90	
	10	102	5240.0149	2.84	5240.0151	2.88	
		120	5240.0134	2.56	5240.0119	2.27	
		138	5240.0149	2.84	5240.0132	2.52	
	20	102	5240.0144	2.75	5240.0150	2.86	
		120	5240.0163	3.11	5240.0199	3.80	
		138	5240.0182	3.47	5240.0160	3.05	
	30	102	5240.0194	3.70	5240.0194	3.70	
		120	5240.0117	2.23	5240.0129	2.46	
		138	5240.0105	2.00	5240.0183	3.49	
	40	102	5240.0125	2.39	5240.0161	3.07	
		120	5240.0146	2.79	5240.0133	2.54	
		138	5240.0101	1.93	5240.0195	3.72	
	149	0	102	5745.0114	1.98	5745.0198	3.45
			120	5745.0120	2.09	5745.0185	3.22
			138	5745.0105	1.83	5745.0105	1.83
10		102	5745.0198	3.45	5745.0167	2.91	
		120	5745.0170	2.96	5745.0104	1.81	
		138	5745.0120	2.09	5745.0188	3.27	
20		102	5745.0180	3.13	5745.0140	2.44	
		120	5745.0127	2.21	5745.0151	2.63	
		138	5745.0148	2.58	5745.0200	3.48	
30		102	5745.0152	2.65	5745.0181	3.15	
		120	5745.0198	3.45	5745.0132	2.30	
		138	5745.0167	2.91	5745.0149	2.59	
40		102	5745.0136	2.37	5745.0200	3.48	
		120	5745.0153	2.66	5745.0149	2.59	
		138	5745.0136	2.37	5745.0165	2.87	



157	0	102	5785.0125	2.16	5785.0197	3.41
		120	5785.0111	1.92	5785.0133	2.30
		138	5785.0101	1.75	5785.0184	3.18
	10	102	5785.0166	2.87	5785.0116	2.01
		120	5785.0164	2.83	5785.0170	2.94
		138	5785.0151	2.61	5785.0163	2.82
	20	102	5785.0147	2.54	5785.0194	3.35
		120	5785.0179	3.09	5785.0112	1.94
		138	5785.0125	2.16	5785.0170	2.94
	30	102	5785.0114	1.97	5785.0198	3.42
		120	5785.0121	2.09	5785.0192	3.32
		138	5785.0176	3.04	5785.0108	1.87
	40	102	5785.0142	2.45	5785.0171	2.96
		120	5785.0183	3.16	5785.0177	3.06
		138	5785.0111	1.92	5785.0144	2.49
165	0	102	5825.0104	1.79	5825.0176	3.02
		120	5825.0120	2.06	5825.0197	3.38
		138	5825.0158	2.71	5825.0149	2.56
	10	102	5825.0120	2.06	5825.0195	3.35
		120	5825.0121	2.08	5825.0198	3.40
		138	5825.0179	3.07	5825.0196	3.36
	20	102	5825.0185	3.18	5825.0176	3.02
		120	5825.0187	3.21	5825.0159	2.73
		138	5825.0135	2.32	5825.0188	3.23
	30	102	5825.0148	2.54	5825.0194	3.33
		120	5825.0182	3.12	5825.0182	3.12
		138	5825.0144	2.47	5825.0193	3.31
	40	102	5825.0113	1.94	5825.0143	2.45
		120	5825.0112	1.92	5825.0116	1.99
		138	5825.0104	1.79	5825.0122	2.09