



FCC TEST REPORT

According to

CFR47 §15.247

Applicant	: Amcrest Technologies LLC
Address	: 16727 Park Row Dr.Houston, TX 77084
Manufacturer	: Zhejiang Dahua Vision Technology Co., Ltd.
Address	: No.1199, Bin'an road, Binjiang District, Hangzhou,P.R.China.
Equipment	: 2K/3MP Dual-band Fixed Wireless IP Camera
Model No.	: IP3M-HX2B , IP3M-HX2W
FCC ID	: ZZ2AMC015
IC ID	: 21923-AMC015
Test Period	: Jul.22,2017~ Jul.25, 2017

- The test result refers exclusively to the test presented test model / sample.
- Without written approval of **Cerpass Technology Corporation Test Laboratory**, the test report shall not be reproduced exc- ept in full.
- The test report must not be used by the clients to claim product certification approval by any agency of the Government.

I HEREBY CERTIFY THAT :

The measurements shown in this test report were made in accordance with the procedures given in **ANSI C63.10 – 2013&RSS-247,Issue 2&RSS-Gen&FCC Part15.247**and the energy emitted by this equipment was **passed**.

Approved by:

Laboratory Accreditation:

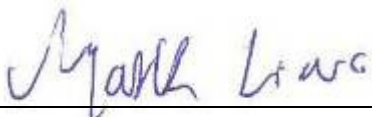

Mark Liao / Assistant Manager



Cerpass Technology Corporation Test Laboratory

TAF LAB Code:

1439



Contents

1. Report of Measurements and Examinations	5
2. General Info.....	6
2.1 Description of EUT.....	6
2.2 Description of wireless module	7
2.3 Description of Antenna.....	7
2.4 Carrier Frequency of Channels.....	8
2.5 The Worst Case Configuration.....	8
2.6 EUT Exercise Software.....	8
2.7 Power Parameter Value of the test software	9
2.8 Duty cycle.....	10
2.9 Support equipment.....	11
3. General Information of Test Site	12
3.1 Information of Test Site	12
3.2 Measuring Equipment.....	13
3.3 Measurement Uncertainty.....	14
4. AC Conducted Emission Measurement	15
4.1 Test Limit.....	15
4.2 Test Standard	15
4.3 Test Procedures	15
4.4 Test Setup Layout	16
4.5 Test Result	17
5. Radiated Emission Measurement.....	19
5.1 Test Limit.....	19
5.2 Test Standard	19
5.3 Test Procedures.....	20
5.4 Test Setup Layout.....	21
5.5 Test Result	23
6. 6dB Bandwidth Measurement	31
6.1 Test Limit.....	31
6.2 Test Standard	31
6.3 Test Procedures	31
6.4 Test Setup Layout	31
6.5 Test Result	32
7. Output Power Measurement.....	36
7.1 Test Limit.....	36
7.2 Test Standard	36
7.3 Test Procedures	36
7.4 Test Setup Layout	36
7.5 Test Result	37
8. Power Spectral Density Measurement	38
8.1 Test Limit.....	38
8.2 Test Standard	38
8.3 Test Procedures.....	38



8.4 Test Setup Layout	38
8.5 Test Result	39
9. Conducted Band Edge and Out-of-Band Emissions Measurement	44
9.1 Test Limit	44
9.2 Test Standard	44
9.3 Test Procedures	45
9.4 Test Setup Layout	45
9.5 Test Result	46
10. Radiated Emission Band Edge Measurement	55
10.1 Test Limit	55
10.2 Test Standard	55
10.3 Test Procedure	55
10.4 Test Setup Layout	56
10.5 Test Result	57



History of this Test Report

Report No.	Version	Issue Date	Description
SEFI1708002	Rev 01	Aug.16, 2017	Original.



1. Report of Measurements and Examinations

Performed Test Item	Normative References	Test Performed	Deviation	Result
Conducted Emission	FCC CFR Title 47 Part 15 Subpart C: 2016 Section 15.207	Yes	N/A	Pass
Radiated Emission	FCC CFR Title 47 Part 15 Subpart C: 2016 Section 15.209 RSS-Gen Issue 4 November 2014 Section 6.13	Yes	No	Pass
RF Antenna Conducted Spurious	FCC CFR Title 47 Part 15 Subpart C: 2016 Section 15.247(d) RSS-247 Issue 2 February 2017 Section 5.5	Yes	No	Pass
Radiated Emission Band Edge	FCC CFR Title 47 Part 15 Subpart C: 2016 15.247(d) RSS-247 Issue 2 February 2017 Section 5.5	Yes	No	Pass
Operation Frequency Range of 20dB Bandwidth	FCC CFR Title 47 Part 15 Subpart C: 2016 15.215(c)	Yes	No	Pass
Occupied Bandwidth	FCC CFR Title 47 Part 15 Subpart C: 2016 Section 15.247(a)(2) RSS-247 Issue 2 February 2017 Section 5.2(a)	Yes	No	Pass
Output Power	FCC CFR Title 47 Part 15 Subpart C: 2016 Section 15.247(b)(3) RSS-247 Issue 2 February 2017 Section 5.4(d)	Yes	No	Pass
Power Spectral Density	FCC CFR Title 47 Part 15 Subpart C: 2016 Section 15.247(e) RSS-247 Issue 2 February 2017 Section 5.2(b)	Yes	No	Pass



2. General Info

2.1 Description of EUT

Product name	2K/3MP Dual-band Fixed Wireless IP Camera	
Model No.	IP3M-HX2B , IP3M-HX2W	
Power supply	ED1-050100UA	
	Input:	100~240V AC 50/60Hz 0.2A
	Output:	5.0V  1.0A



2.2 Description of wireless module

WLAN	WIFI-2-R811USA2
Spreading	802.11b: CCK, DQPSK, DBPSK and DSSS 802.11g: 64QAM, 16QAM, QPSK, BPSK and OFDM 802.11n: BPSK, QPSK, 16QAM, 64QAM, 256QAM and OFDM
Frequency Range	802.11b/g/n(20MHz): 2412-2462MHz 802.11n(40MHz): 2422-2452MHz
Number of Channels	802.11b/g/n (20MHz):11 802.11n (40MHz): 7
Data Rate	802.11b: 1, 2, 5.5, 11Mbps 802.11g: 6, 9, 12, 18, 24, 36, 48, 54Mbps 802.11n: MCS0~MCS7

Note: For more details, please refer to the EUT User manual.

2.3 Description of Antenna

Antenna	Peak Gain
PCB Antenna	6.12dBi for 2.40~2.50GHz band



2.4 Carrier Frequency of Channels

802.11b, 802.11g, 802.11n(20MHz)			
Channel	Frequency(MHz)	Channel	Frequency(MHz)
01	2412	08	2447
02	2417	09	2452
03	2422	10	2457
04	2427	11	2462
05	2432		
06	2437		
07	2442	---	---

802.11n(40MHz)			
Channel	Frequency(MHz)	Channel	Frequency(MHz)
01	---	08	2447
02	---	09	2452
03	2422	---	---
04	2427	---	---
05	2432	---	---
06	2437	---	---
07	2442	---	---

2.5 The Worst Case Configuration

Data rate Configuration:

Modulation Mode	Worst Data Rate
802.11b	1Mbps
802.11g	6Mbps
802.11n(HT20)	MCS0
802.11n(HT40)	MCS0

Note: Power output test was verified over all data rates of each mode, and then choose the maximum power output for final test of each channel shown as the table.

2.6 EUT Exercise Software

1	Turn on the power of equipment.
2	Run 'SecureCRTPortable', input RF test command and set the test mode and channel, then press Transmit to start continue transmit.



2.7 Power Parameter Value of the test software

Mode	Frequency (MHz)	Power Setting
802.11b	2412	53
	2437	63
	2462	50
802.11g	2412	58
	2437	63
	2462	58
802.11n(20MHz)	2412	58
	2437	63
	2462	56
802.11n(40MHz)	2422	56
	2437	63
	2452	53



2.8 Duty cycle

Test Item	Duty cycle
-----------	------------

Mode	Frequency (MHz)	Measurement (%)
802.11b	2437	100
802.11g	2437	100
802.11n(20MHz)	2437	100
802.11n(40MHz)	2437	100



2.9 Support equipment

Product	Manufacturer	Model No.	Serial No.	Power Cord
Notebook PC	DELL	Inspiron 3543	N/A	N/A

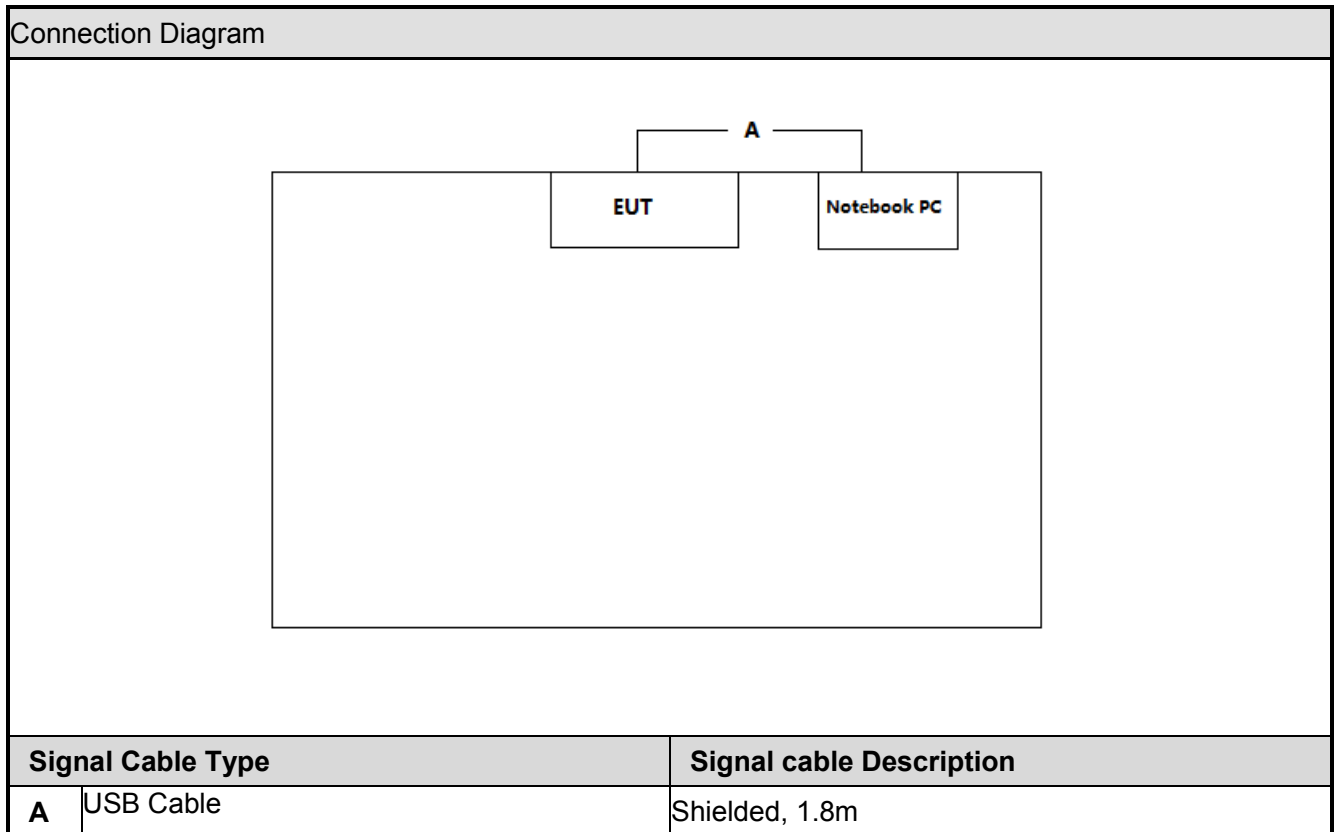



3. General Information of Test Site

3.1 Information of Test Site

Test Site :	Cerpess Technology Corporation Test Laboratory Location: No.10 Lane2 Lianfu Street Luzhu District, Taoyuan City Taiwan ROC <u>Tel:+886-3-3226-888</u> Fax:+886-3-3226-881
FCC Registration Number :	TW1439
IC Registration Number :	4934B-1
VCCI	T-2205 for Telecommunication Test C-4663 for Conducted emission test R-4399, R-4218 for Radiated emission test G-812, G-813 for radiated disturbance above 1GHz



3.2 Measuring Equipment

Instrument/Ancillary	Manufacturer	Model No.	Serial No.	Calibration Date	Valid Date.
Test Receiver	R&S	ESCI	100565	2017.03.26	2018.03.25
AMN	R&S	ESH2-Z5	100182	2016.09.06	2017.09.05
Two-Line V-Network	R&S	ENV216	100325	/	/
Pulse Limiter	R&S	ESH3-Z2	100529	2017.03.26	2018.03.25
Temperature/ Humidity Meter	Zhicheng	ZC1-11	CEP-TH-004	2017.03.29	2018.03.28
EZ-EMC	Fala	Ver CT3A1	N/A	N/A	N/A

Instrument/Ancillary	Manufacturer	Model No.	Serial No.	Calibration Date	Valid Date.
EMI Test Receiver	R&S	ESCI	101183	2017.03.26	2018.03.25
Preamplifier	songyi	EM330	60618	2017.03.26	2018.03.25
Preamplifier	Agilent	8449B	3008A02342	2017.03.26	2018.03.25
Bilog Antenna	Sunol Science	JB1	A072414-1	2017.04.16	2018.04.15
Broad-Band Horn Antenna	Schwarzbeck	BBHA9120D	9120D-618	2017.04.16	2018.04.15
Broad-Band Horn Antenna	Schwarzbeck	BBHA9170	9170-347	2017.04.16	2018.04.15
Preamplifier	COM-POWER	PA-840	711885	2017.03.26	2018.03.25
Spectrum Analyzer	R&S	FSP40	100324	2017.03.26	2018.03.25
Spectrum Analyzer	KEYSIGHT	N9010A	MY54200207	2017.03.17	2018.03.16
Temperature/ Humidity Meter	Zhicheng	ZC1-11	CEP-TH-002	2017.03.29	2018.03.28
EZ-EMC	Fala	Ver CT3A1	N/A	N/A	N/A



3.3 Measurement Uncertainty

ISO/IEC 17025 requires that an estimate of the measurement uncertainties associated with the emissions test results be included in the report. The measurement uncertainties given below are based on a 95% confidence level (based on a coverage factor (k=2)).

Measurement Item	Measurement Frequency	Polarization	Uncertainty
Conducted Emission	9 kHz ~ 30 MHz	Line / Neutral	± 2.9076 dB
Radiated Emission	9 kHz ~ 40,000 MHz	Vertical / Horizontal	± 0.948 dB
Spurious Emission (Conducted)	-	-	± 4.011 dB
Maximum Peak and Average Output Power	-	-	± 0.322 dB
Power Spectral Density	-	-	± 0.322 dB
Bandwidth	-	-	74.224Hz



4. AC Conducted Emission Measurement

4.1 Test Limit

Conducted Emissions were measured from 150 kHz to 30 MHz with a bandwidth of 9 KHz on the 120 VAC power and return leads of the EUT according to the methods defined in ANSI C63.10-2013 Section 6.2. The EUT was placed on a nonmetallic stand in a shielded room 0.8 meters above the ground plane as shown in section 6.2.2. The interface cables and equipment positioning were varied within limits of reasonable applications to determine the position produced maximum conducted emissions.

FCC Part 15 Subpart C Paragraph 15.207 Limits		
Frequency (MHz)	Quasi Peak (dB μ V)	Average (dB μ V)
0.15 – 0.5	66-56*	56-46*
0.5 – 5.0	56	46
5.0 – 30.0	60	50

*Decreases with the logarithm of the frequency.

4.2 Test Standard

Tested according to ANSI C63.10: 2013 Section 6.2 for compliance to FCC 47CFR 15.247 Part15.207 (a) requirements.

4.3 Test Procedures

The EUT was placed on a platform of nominal size, 1 m by 1.5 m, raised 80 cm above the conducting ground plane. The vertical conducting plane was located 40 cm to the rear of the EUT. All other surfaces of EUT were at least 80 cm from any other grounded conducting surface. The EUT and simulators are connected to the main power through a line impedance stabilization network (LISN). The LISN provides a 50 ohm /50uH coupling impedance for the measuring equipment. The peripheral devices are also connected to the main power through a LISN. (Please refer to the block diagram of the test setup and photographs) Each current-carrying conductor of the EUT power cord, except the ground (safety) conductor, was individually connected through a LISN to the input power source.

The excess length of the power cord between the EUT and the LISN receptacle were folded back and forth at the center of the lead to form a bundle not exceeding 40 cm in length.

Conducted emissions were investigated over the frequency range from 0.15MHz to 30MHz using a receiver bandwidth of 9 kHz.



4.4 Test Setup Layout

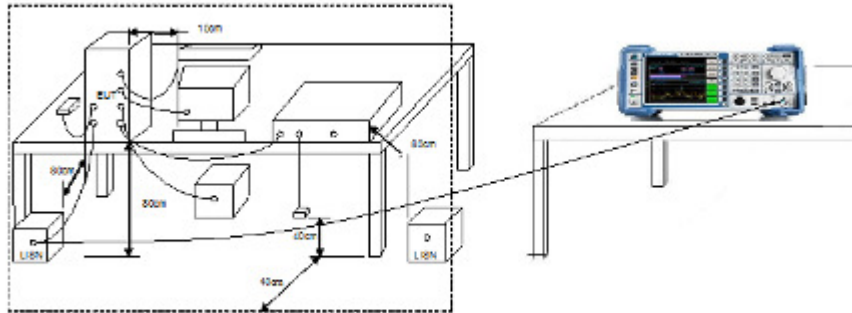



4.5 Test Result

Test Mode :	Mode 1: Normal Operation with WIFI on		
AC Power :	AC 120V/60Hz	Phase:	LINE
Temperature :	26°C	Humidity:	60%
Pressure(mbar) :	1002	Date:	2017/07/27

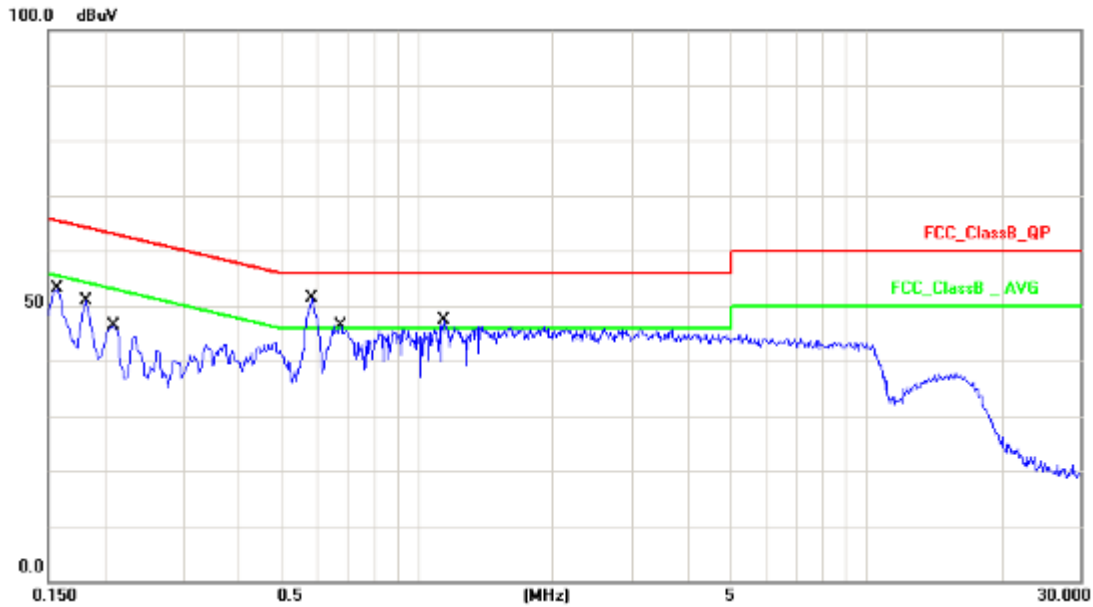

No.	Frequency (MHz)	Factor (dB)	Reading (dBuV)	Level (dBuV)	Limit (dBuV)	Margin (dB)	Detector
1	0.1580	10.13	38.50	48.63	65.57	-16.94	QP
2	0.1580	10.13	23.53	33.66	55.57	-21.91	AVG
3	0.1820	10.12	36.62	46.74	64.39	-17.65	QP
4	0.1820	10.12	23.43	33.55	54.39	-20.84	AVG
5	0.2100	10.12	32.35	42.47	63.21	-20.74	QP
6	0.2100	10.12	21.31	31.43	53.21	-21.78	AVG
7	0.5820	10.16	38.05	48.21	56.00	-7.79	QP
8	0.5820	10.16	29.69	39.85	46.00	-6.15	AVG
9	0.6740	10.15	32.46	42.61	56.00	-13.39	QP
10	0.6740	10.15	24.00	34.15	46.00	-11.85	AVG
11	1.1420	10.16	33.44	43.60	56.00	-12.40	QP
12	1.1420	10.16	22.89	33.05	46.00	-12.95	AVG

Note: Measurement Level = Reading Level + Correct Factor



Test Mode :	Mode 1: Normal Operation with WIFI on		
AC Power :	AC 120V/60Hz	Phase :	NEUTRAL
Temperature :	26°C	Humidity :	60%
Pressure(mbar) :	1002	Date:	2017/07/27

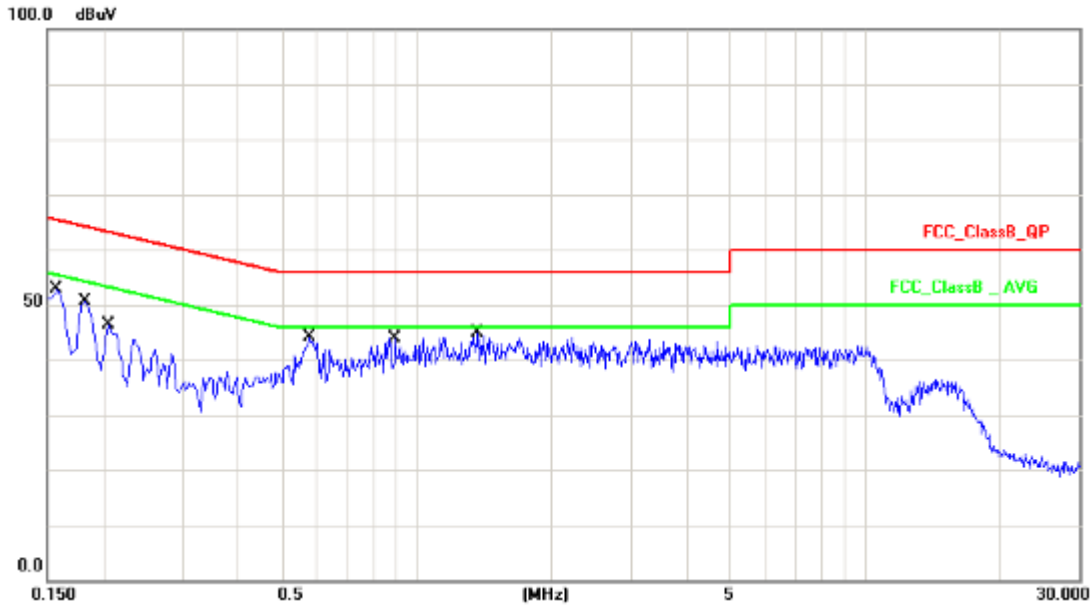

No.	Frequency (MHz)	Factor (dB)	Reading (dBuV)	Level (dBuV)	Limit (dBuV)	Margin (dB)	Detector
1	0.1580	10.13	38.15	48.28	65.57	-17.29	QP
2	0.1580	10.13	20.12	30.25	55.57	-25.32	AVG
3	0.1820	10.13	36.07	46.20	64.39	-18.19	QP
4	0.1820	10.13	18.73	28.86	54.39	-25.53	AVG
5	0.2060	10.13	32.49	42.62	63.37	-20.75	QP
6	0.2060	10.13	14.80	24.93	53.37	-28.44	AVG
7	0.5780	10.15	29.45	39.60	56.00	-16.40	QP
8	0.5780	10.15	22.17	32.32	46.00	-13.68	AVG
9	0.8980	10.17	25.90	36.07	56.00	-19.93	QP
10	0.8980	10.17	14.66	24.83	46.00	-21.17	AVG
11	1.3700	10.18	26.30	36.48	56.00	-19.52	QP
12	1.3700	10.18	15.63	25.81	46.00	-20.19	AVG

Note: Measurement Level = Reading Level + Correct Factor



5. Radiated Emission Measurement

5.1 Test Limit

In any 100kHz bandwidth outside the frequency band in which the spread spectrum or digitally modulated intentional radiator is operating, the radio frequency power that is produced by the intentional radiator shall be at least 20dB below that in the 100kHz bandwidth within the band that contains the highest level of the desired power, based on either an RF conducted or a radiated measurement. If the transmitter measurement is based on the maximum conducted output power, the attenuation required under this paragraph shall be 30dB instead of 20dB. In addition, radiated emissions which fall in section 15.205(a) the restricted bands must also comply with the radiated emission limit specified in section 15.209(a).

FCC Part 15 Subpart C Paragraph 15.209		
FREQUENCIES (MHz)	FIELD STRENGTH (micro volts/meter)	MEASUREMENT DISTANCE (meters)
0.009~0.490	2400/F(kHz)	300
0.490~1.705	24000/F(kHz)	30
1.705~30.0	30	30
30~88	100	3
88~216	150	3
216~960	200	3
Above 960	500	3

Note 1: The lower limit shall apply at the transition frequency.

Note 2: Distance refers to the distance in meters between the measuring instrument Antenna and the closed point of any part of the device or system.

Note 3: E field strength (dBuV/m) = 20 log E field strength (uV/m)

Note 4: **Except as provided in paragraph (g), fundamental emissions from intentional radiators operating under this section shall not be located in the frequency bands 54-72 MHz, 76-88 MHz, 174-216 MHz or 470-806 MHz. However, operation within these frequency bands is permitted under other sections of this part, e.g., §§15.231 and 15.241.

5.2 Test Standard

KDB 558074 D01v04 - Section 12.2.3 (quasi-peak measurements)

KDB 558074 D01v04 - Section 12.2.4 (peak power measurements)

KDB 558074 D01v04- Section 12.2.5 (average power measurements)



5.3 Test Procedures

Quasi-Peak Field Strength Measurements:

The specifications for measurements using the CISPR quasi-peak detector can be found in Publication 16 of the International Special Committee on Radio Frequency Interference (CISPR) of the International Electrotechnical Commission.

As an alternative to CISPR quasi-peak measurement, compliance can be demonstrated to the applicable emission limits using a peak detector.

Peak Field Strength Measurements:

Analyzer center frequency was set to the frequency of the radiated spurious emission of interest

1. RBW=As specified in Table 1
2. VBW=3×RBW
3. Detector=Peak
4. Trace mode=Max hold
5. Sweep time=Auto couple
6. Allow the trace to stabilize

Table 1-RBW as a function of frequency

Frequency	RBW
9 ~ 150kHz	200 ~ 300Hz
0.15 ~ 30MHz	9 ~ 10kHz
30 ~ 1000MHz	100 ~ 120kHz
> 1000MHz	1MHz

AVE Field Strength Measurements:

Analyzer center frequency was set to the frequency of the radiated spurious emission of interest

1. RBW= 1MHz
2. VBW≥1/T
3. Detector=Peak
4. Trace mode=Max hold
5. Sweep time=Auto couple
6. Allow max hold to run for at least 50 times(1/duty cycle) trace

Do as an alternative, the instrument may be set to linear detector mode. Ensure that video filtering is applied in linear voltage domain (rather than in a log or dB domain). Some instruments require linear display mode in order to accomplish this. Others have a setting for Average-VBW Type, which can be set to "Voltage" regardless of the display mode



5.4 Test Setup Layout

9kHz~30MHz Test Setup

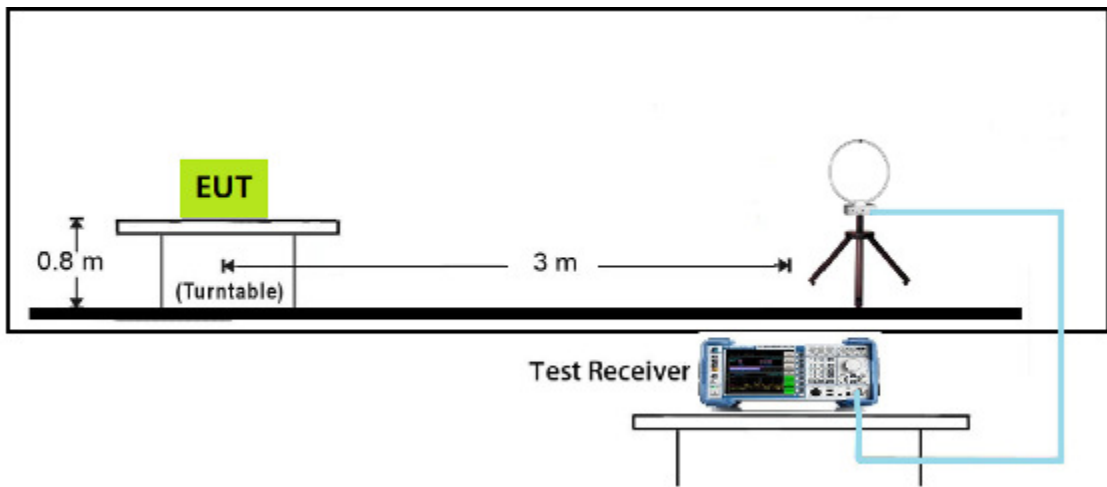

30MHz~1GHz Test Setup

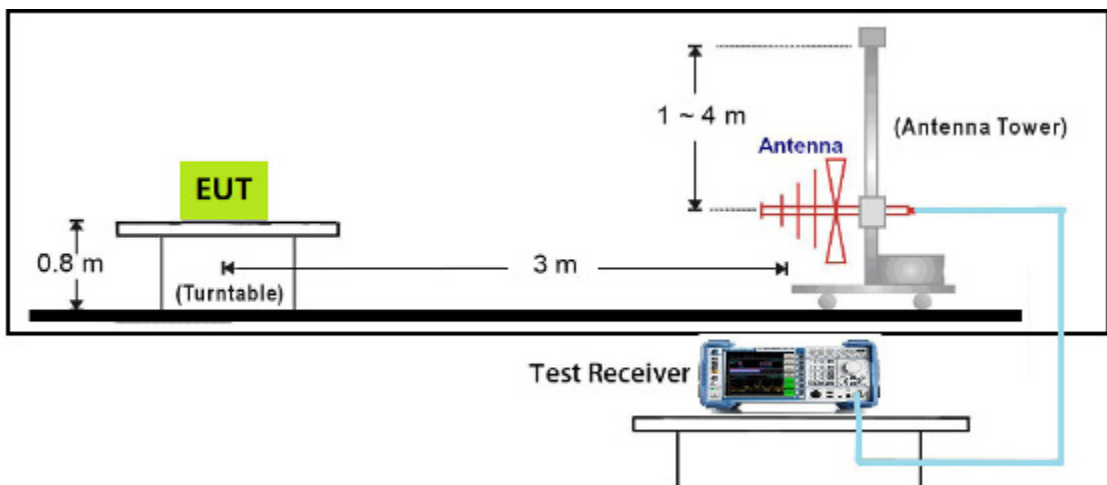



1GHz~18GHz Test Setup

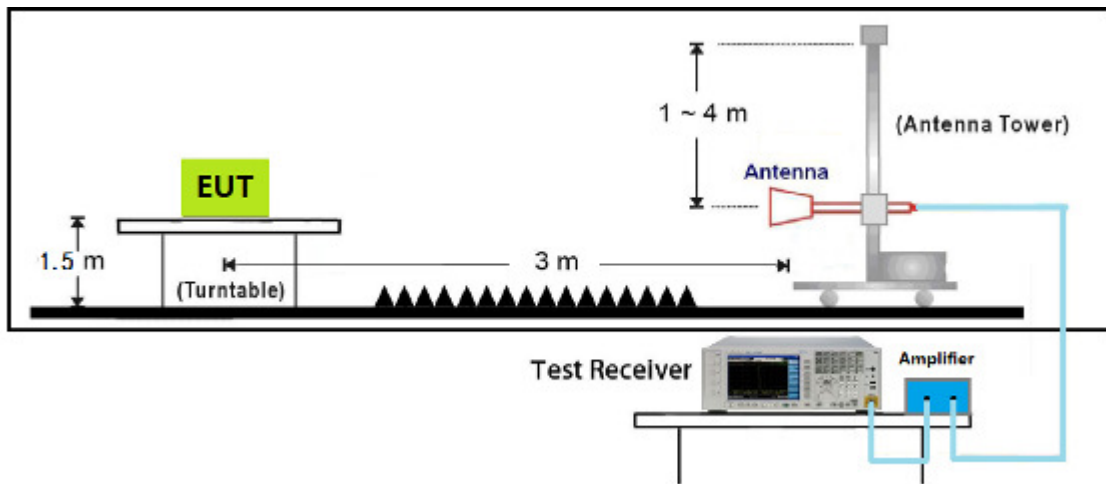

18GHz~40GHz Test Setup

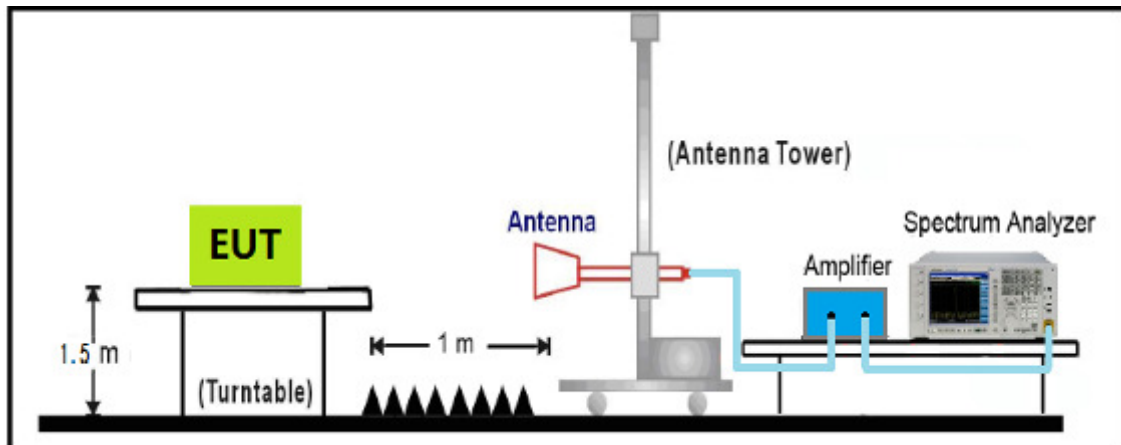



5.5 Test Result

The worst case of Radiated Emission below 1GHz:

Limit: FCC_Part15.209_RE(3m)	Margin: 0
Probe: N/A	Polarity: Horizontal
EUT:IP CAMERA	Power: AC 120V/60Hz
Note: Mode1: Transmit at channel 2437MHz by 802.11b	

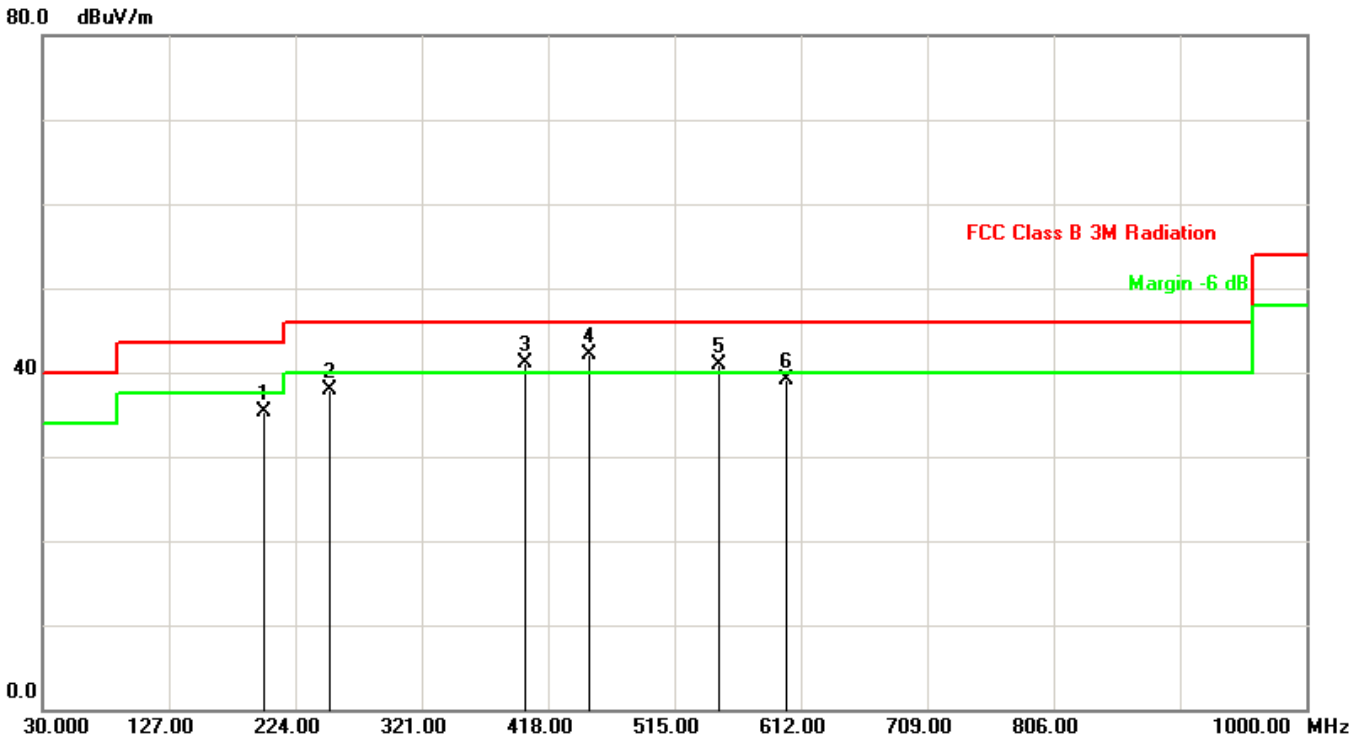

No.	Frequency (MHz)	Factor (dB/m)	Reading (dBuV)	Level (dBuV/m)	Limit (dBuV/m)	Margin (dB)	Det.
1	199.7500	-12.43	47.75	35.32	43.50	-8.18	QP
2	250.1899	-11.02	48.90	37.88	46.00	-8.12	QP
3	400.5400	-5.67	46.71	41.04	46.00	-4.96	QP
4	450.0099	-6.47	48.67	42.20	46.00	-3.80	QP
5	549.9199	-3.67	44.48	40.81	46.00	-5.19	QP
6	600.3600	-1.94	41.02	39.08	46.00	-6.92	QP

Note: Measure Level (dBuV/m) = Reading Level (dBuV) + Factor(dB).

Factor (dB)=Cable Loss(dB) + Antenna Factor (dB/m) - Pre_Amplifier Gain(dB)



Limit: FCC_Part15.209_RE(3m)	Margin: 0
Probe: N/A	Polarity: Vertical
EUT:IP CAMERA	Power: AC 120V/60Hz
Note: Mode1: Transmit at channel 2437MHz by 802.11b	

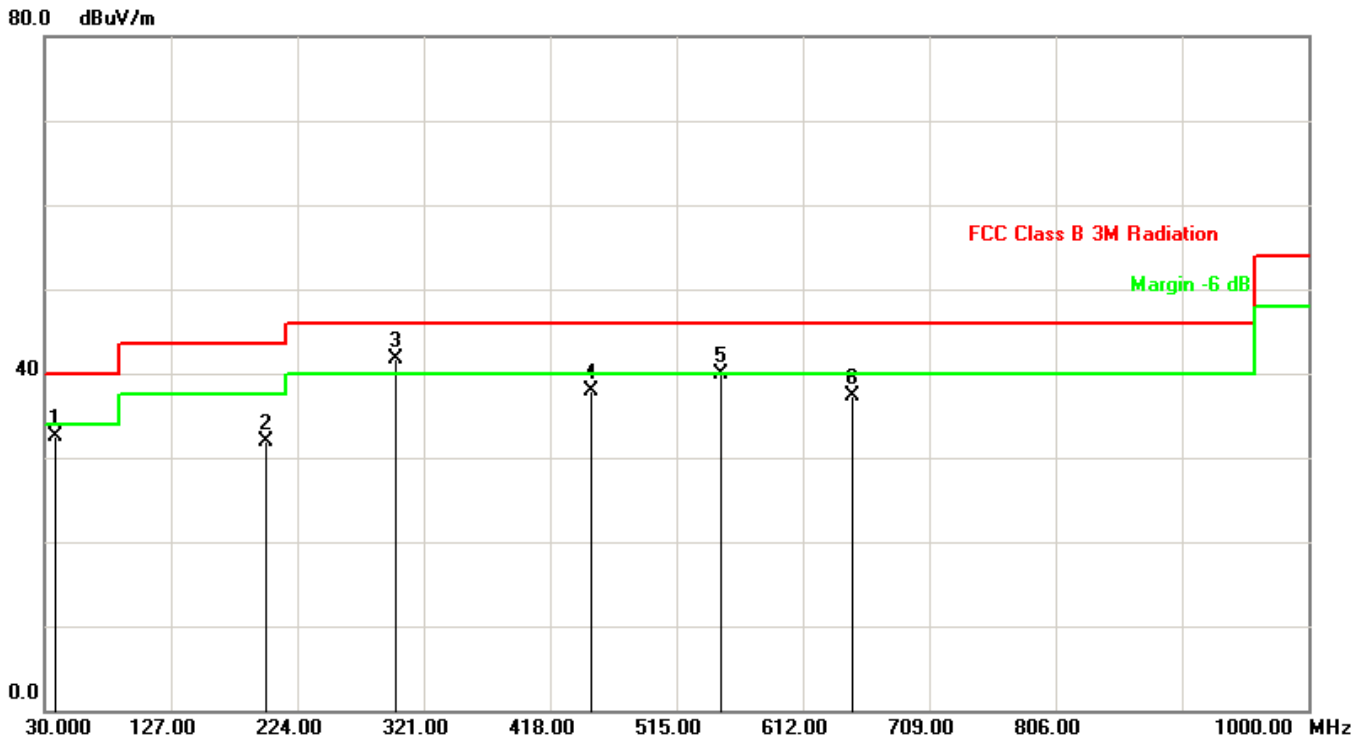

No.	Frequency (MHz)	Factor (dB/m)	Reading (dBuV)	Level (dBuV/m)	Limit (dBuV/m)	Margin (dB)	Det.
1	38.7299	-5.77	38.36	32.59	40.00	-7.41	QP
2	199.7500	-12.43	44.41	31.98	43.50	-11.52	QP
3	299.6600	-8.29	50.07	41.78	46.00	-4.22	QP
4	450.0099	-6.47	44.33	37.86	46.00	-8.14	QP
5	549.9199	-3.67	43.62	39.95	46.00	-6.05	QP
6	649.8300	-2.30	39.53	37.23	46.00	-8.77	QP

Note: Measure Level (dBuV/m) = Reading Level (dBuV) + Factor(dB).

Factor (dB)=Cable Loss(dB) + Antenna Factor (dB/m) - Pre_Amplifier Gain(dB)

**Radiated Emission above 1GHz:**

Mode1: Transmit by 802.11b

CH	Antenna	Frequency (MHz)	Reading Level (dBuV/m)	Factor (dB)	Measure Level (dBuV/m)	Limit (dBuV/m)	Margin (dB)	Detector
1	H	4824.0	48.3	3.45	51.8	54(note3)	-2.3	PK
	H	7236.0	42.8	8.27	51.1	54(note3)	-2.9	PK
	V	4824.0	44.7	3.45	48.2	54(note3)	-5.8	PK
	V	7236.0	42.9	8.27	51.2	54(note3)	-2.8	PK
6	H	4874.0	48.6	3.42	52.0	54(note3)	-2.0	PK
	H	7311.0	44.6	8.26	52.9	54(note3)	-1.1	PK
	V	4874.0	49.8	3.42	53.2	54(note3)	-0.8	PK
	V	7311.0	42.1	8.26	50.4	54(note3)	-3.6	PK
11	H	4924.0	46.4	3.39	49.8	54(note3)	-4.2	PK
	H	7386.0	42.5	8.24	50.7	54(note3)	-3.3	PK
	V	4924.0	43.2	3.39	46.6	54(note3)	-7.4	PK
	V	7386.0	42.3	8.24	50.5	54(note3)	-3.5	PK

Note: 1. Measure Level = Reading Level + Factor.

2. The test trace is same as the ambient noise (the test frequency range: 9kHz~30MHz, 18GHz~25GHz), therefore no data appear in the report.

3. This limit applies for using average detector, if the test result on peak is lower than average limit, then average measurement needn't be performed.



Mode2: Transmit by 802.11g

CH	Antenna	Frequency (MHz)	Reading Level (dBuV/m)	Factor (dB)	Measure Level (dBuV/m)	Limit (dBuV/m)	Margin (dB)	Detector
1	H	4824.0	46.5	3.45	50.0	54(note3)	-4.1	PK
	H	7236.0	40.3	8.27	48.6	54(note3)	-5.4	PK
	V	4824.0	42.7	3.45	46.2	54(note3)	-7.8	PK
	V	7236.0	40.7	8.27	49.0	54(note3)	-5.0	PK
6	H	4874.0	46.7	3.42	50.1	54(note3)	-3.9	PK
	H	7311.0	43.5	8.26	51.8	54(note3)	-2.2	PK
	V	4874.0	47.2	3.42	50.6	54(note3)	-3.4	PK
	V	7311.0	41.9	8.26	50.2	54(note3)	-3.8	PK
11	H	4924.0	44.6	3.39	48.0	54(note3)	-6.0	PK
	H	7386.0	41.7	8.24	49.9	54(note3)	-4.1	PK
	V	4924.0	42.9	3.39	46.3	54(note3)	-7.7	PK
	V	7386.0	40.3	8.24	48.5	54(note3)	-5.5	PK

Note: 1. Measure Level = Reading Level + Factor.

2. The test trace is same as the ambient noise (the test frequency range: 9kHz~30MHz, 18GHz~25GHz), therefore no data appear in the report.

3. This limit applies for using average detector, if the test result on peak is lower than average limit, then average measurement needn't be performed.



Mode3: Transmit by 802.11n(20MHz)

CH	Antenna	Frequency (MHz)	Reading Level (dBuV/m)	Factor (dB)	Measure Level (dBuV/m)	Limit (dBuV/m)	Margin (dB)	Detector
1	H	4824.0	46.2	3.45	49.7	54(note3)	-4.3	PK
	H	7236.0	40.1	8.27	48.4	54(note3)	-5.6	PK
	V	4824.0	43.4	3.45	46.9	54(note3)	-7.2	PK
	V	7236.0	41.7	8.27	50.0	54(note3)	-4.0	PK
6	H	4874.0	43.2	3.42	46.6	54(note3)	-7.4	PK
	H	7311.0	41.3	8.26	49.6	54(note3)	-4.4	PK
	V	4874.0	45.6	3.42	49.0	54(note3)	-5.0	PK
	V	7311.0	41.3	8.26	49.6	54(note3)	-4.4	PK
11	H	4924.0	43.1	3.39	46.5	54(note3)	-7.5	PK
	H	7386.0	40.6	8.24	48.8	54(note3)	-5.2	PK
	V	4924.0	41.9	3.39	45.3	54(note3)	-8.7	PK
	V	7386.0	40.2	8.24	48.4	54(note3)	-5.6	PK

Note: 1. Measure Level = Reading Level + Factor.

2. The test trace is same as the ambient noise (the test frequency range: 9kHz~30MHz, 18GHz~25GHz), therefore no data appear in the report.

3. This limit applies for using average detector, if the test result on peak is lower than average limit, then average measurement needn't be performed.



Mode4: Transmit by 802.11n(40MHz)

CH	Antenna	Frequency (MHz)	Reading Level (dBuV/m)	Factor (dB)	Measure Level (dBuV/m)	Limit (dBuV/m)	Margin (dB)	Detector
3	H	4844.0	43.1	3.43	46.5	54(note3)	-7.5	PK
	H	7266.0	40.5	8.25	48.8	54(note3)	-5.3	PK
	V	4844.0	42.7	3.43	46.1	54(note3)	-7.9	PK
	V	7266.0	40.6	8.25	48.9	54(note3)	-5.2	PK
6	H	4874.0	42.7	3.42	46.1	54(note3)	-7.9	PK
	H	7311.0	41.1	8.26	49.4	54(note3)	-4.6	PK
	V	4874.0	42.6	3.42	46.0	54(note3)	-8.0	PK
	V	7311.0	40.5	8.26	48.8	54(note3)	-5.2	PK
9	H	4904.0	41.8	3.36	45.2	54(note3)	-8.8	PK
	H	7356.0	40.5	8.22	48.7	54(note3)	-5.3	PK
	V	4904.0	41.6	3.36	45.0	54(note3)	-9.0	PK
	V	7356.0	40.6	8.22	48.8	54(note3)	-5.2	PK

Note: 1. Measure Level = Reading Level + Factor.

2. The test trace is same as the ambient noise (the test frequency range: 9kHz~30MHz, 18GHz~25GHz), therefore no data appear in the report.

3. This limit applies for using average detector, if the test result on peak is lower than average limit, then average measurement needn't be performed.



The worst case of Radiated Emission 1~18GHz:

Site:AC102	Time: 2017/07/23
Limit: FCC_Part15.209_RE(3m)	Margin: 0
Probe: N/A	Polarity: Horizontal
EUT:IP CAMERA	Power: AC 120V/60Hz
Note: Mode: Transmit 802.11b at 2437MHz	

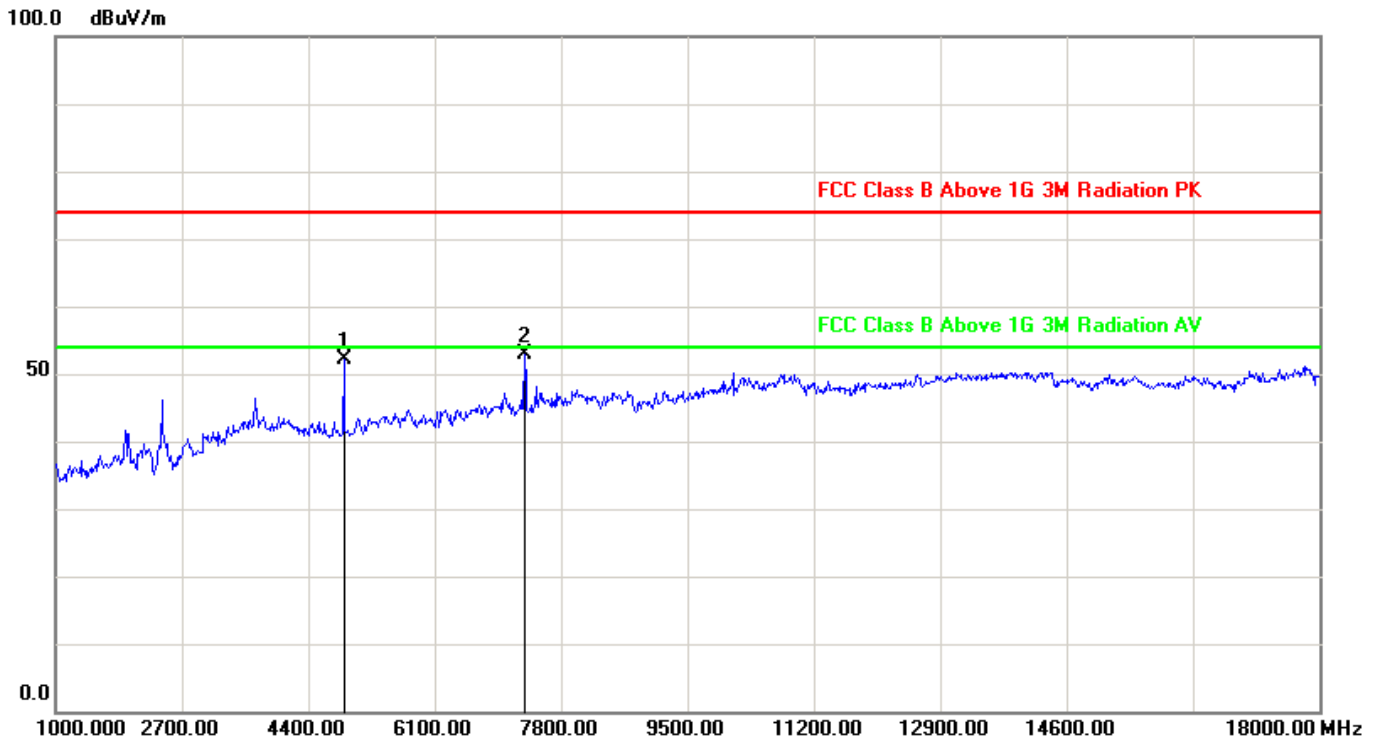

No.	Frequency (MHz)	Factor (dB/m)	Reading (dBuV)	Level (dBuV/m)	Limit (dBuV/m)	Margin (dB)	Det.
1	4874.0	3.42	48.6	52.0	54(note3)	-2.0	peak
2	7311.0	8.26	44.6	52.9	54(note3)	-1.1	peak

Note:

1. All Readings below 1GHz are Quasi-Peak, above are performed with peak and/or AVG measurements as necessary.
2. Measurement Level = Reading Level + Correct Factor
3. The test trace is same as the ambient noise (the test frequency range: 9kHz~30MHz, 18GHz~40GHz), therefore no data appear in the report.



Site:AC102	Time: 2017/07/23
Limit: FCC_Part15.209_RE(3m)	Margin: 0
Probe: N/A	Polarity: Vertical
EUT:IP CAMERA	Power: AC 120V/60Hz
Note: Mode: Transmit 802.11b at 2437MHz	

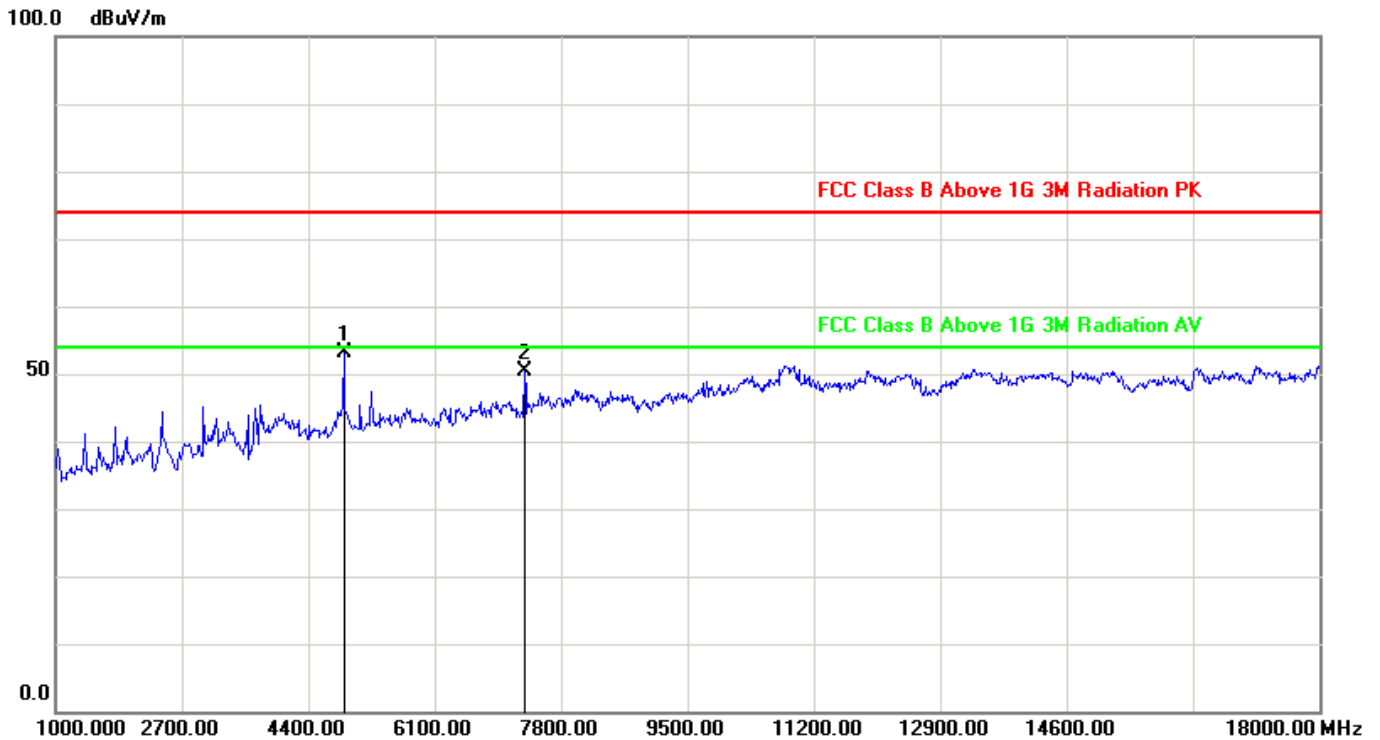

No.	Frequency (MHz)	Factor (dB/m)	Reading (dBuV)	Level (dBuV/m)	Limit (dBuV/m)	Margin (dB)	Det.
1	4874.0	3.42	49.8	53.2	54(note3)	-0.8	peak
2	7311.0	8.26	42.1	50.4	54(note3)	-3.6	peak

Note:

1. All Readings below 1GHz are Quasi-Peak, above are performed with peak and/or AVG measurements as necessary.
2. Measurement Level = Reading Level + Correct Factor
3. The test trace is same as the ambient noise (the test frequency range: 9kHz~30MHz, 18GHz~40GHz), therefore no data appear in the report.



6. 6dB Bandwidth Measurement

6.1 Test Limit

According to FCC part15.247 - Section (a)(2), the minimum 6dB bandwidth shall be at least 500 kHz.

6.2 Test Standard

KDB 558074 D01v04– Section 8.2 Option 2

6.3 Test Procedures

1. Set RBW=100KHz
2. VBW \geq 3 \times RBW
3. Detector=Peak
4. Trace mode=Max hold
5. Sweep time=Auto couple
6. Allow the trace to stabilize
7. The Spectrum's automatic bandwidth measurement capability was used to perform the 6dB bandwidth measurement. The "X" dB bandwidth parameter was set to X = 6. The bandwidth measurement was not influenced by any intermediate power nulls in the fundamental emission.

6.4 Test Setup Layout

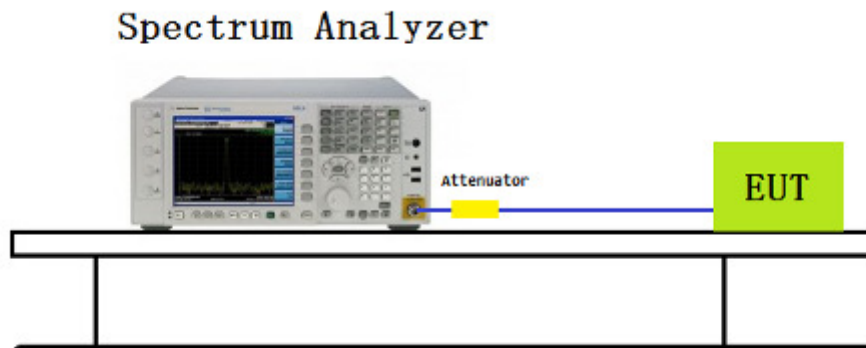



6.5 Test Result

Test Item	Occupied Bandwidth
Test Mode	Mode 1: Transmit by 802.11b

Channel No.	Frequency(MHz)	6dB Bandwidth(MHz)	99% Bandwidth(MHz)
1	2412	10.15	15.739
6	2437	10.16	16.461
11	2462	10.14	15.052

Channel 1 (2412MHz)

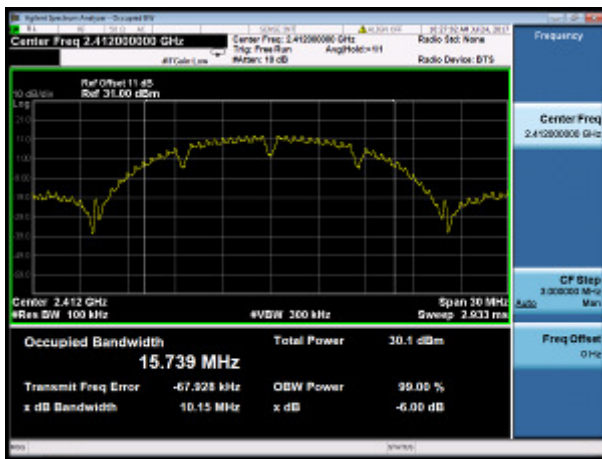

Channel 6 (2437MHz)

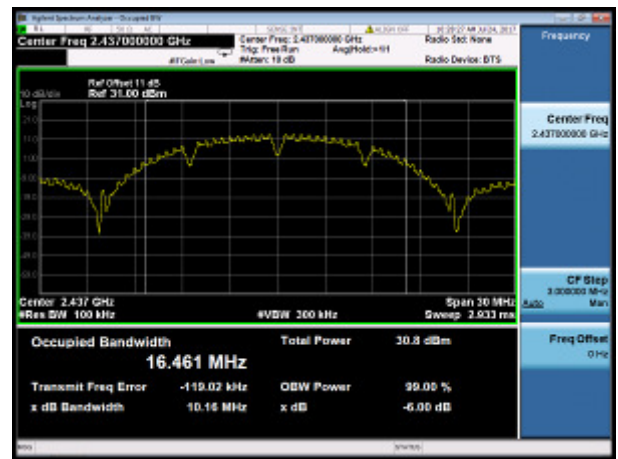

Channel 11 (2462MHz)

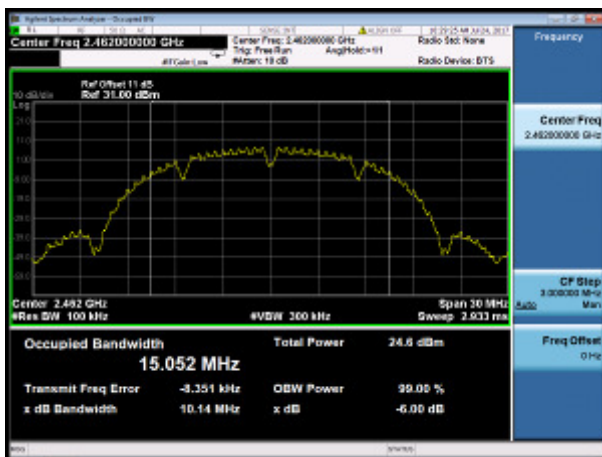



Test Item	Occupied Bandwidth
Test Mode	Mode 2: Transmit by 802.11g

Channel No.	Frequency(MHz)	6dB Bandwidth(MHz)	99% Bandwidth(MHz)
1	2412	16.58	16.552
6	2437	16.56	16.624
11	2462	16.59	16.468

Channel 1 (2412MHz)

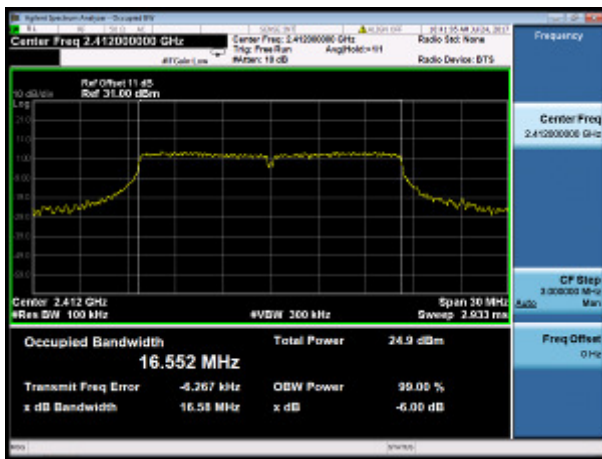

Channel 6 (2437MHz)

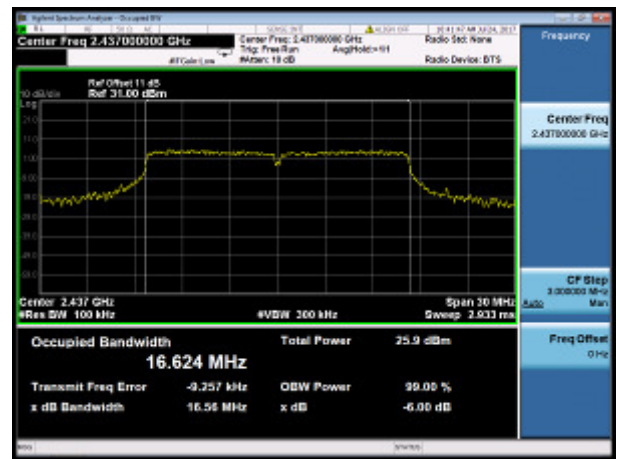

Channel 11 (2462MHz)

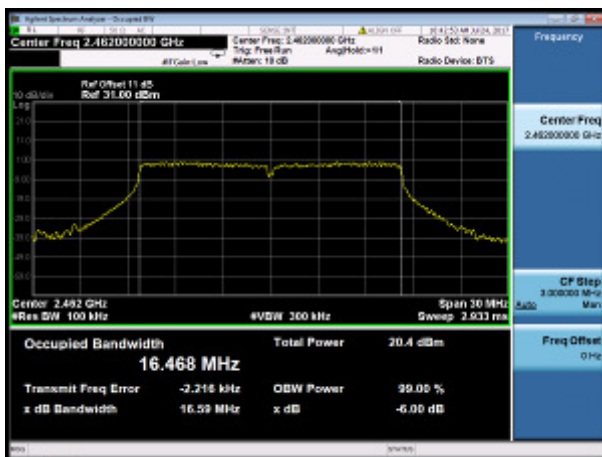



Test Item	Occupied Bandwidth
Test Mode	Mode 3: Transmit by 802.11n(20MHz)

Channel No.	Frequency(MHz)	6dB Bandwidth(MHz)	99% Bandwidth(MHz)
1	2412	17.78	17.710
6	2437	17.78	17.793
11	2462	17.71	17.651

Channel 1 (2412MHz)

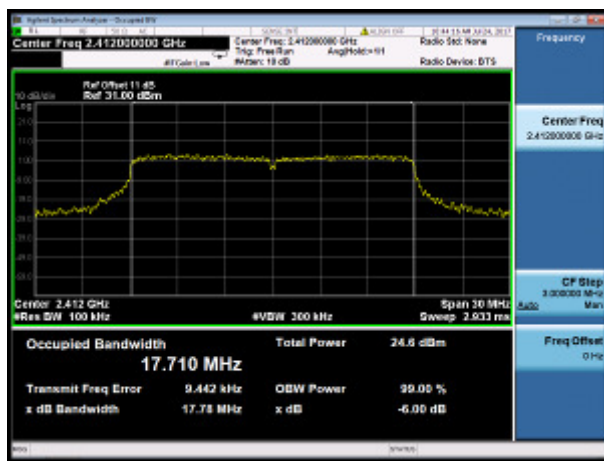

Channel 6 (2437MHz)

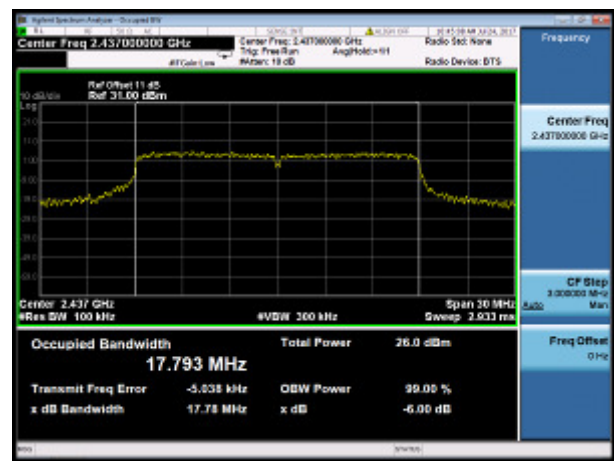

Channel 11 (2462MHz)

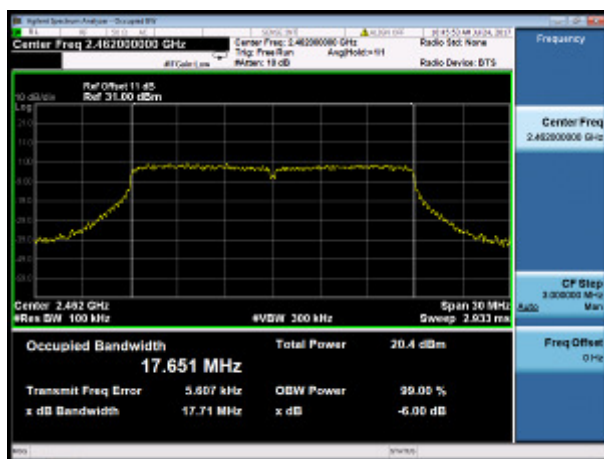



Test Item	Occupied Bandwidth
Test Mode	Mode 4: Transmit by 802.11n(40MHz)

Channel No.	Frequency(MHz)	6dB Bandwidth(MHz)	99% Bandwidth(MHz)
3	2422	36.56	36.208
6	2437	36.52	36.272
9	2452	36.56	36.195

Channel 3 (2422MHz)

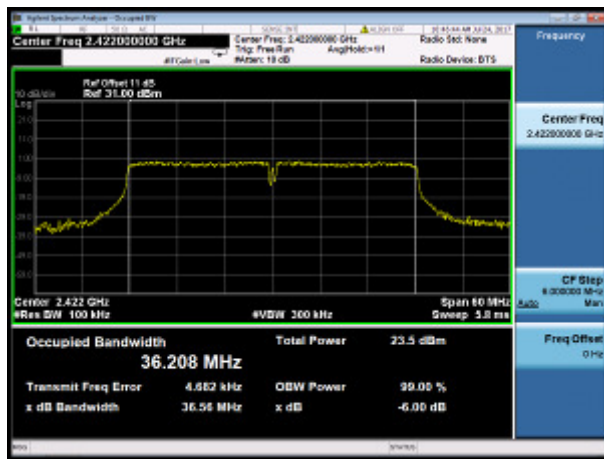

Channel 6 (2437MHz)

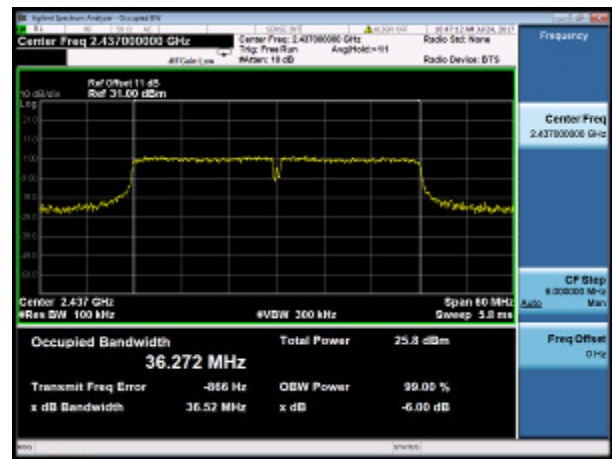

Channel 9 (2452MHz)

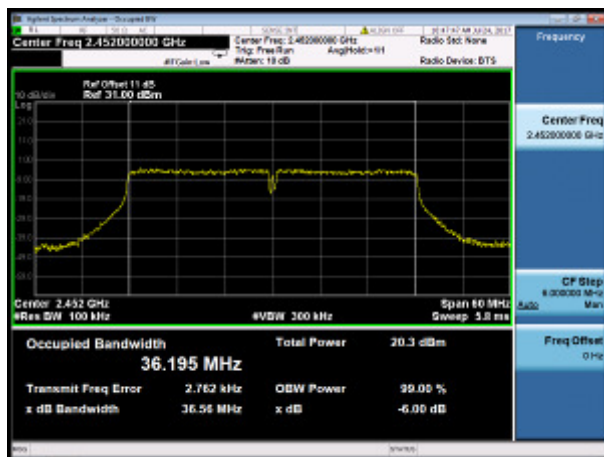



7. Output Power Measurement

7.1 Test Limit

According to FCC part15.247 (b) (3), for systems using digital modulation in the 902-928 MHz, 2400-2483.5 MHz, and 5725-5850MHz bands: 1 Watt. As an alternative to a peak power measurement, compliance with the one Watt limit can be based on a measurement of the maximum conducted output power. Maximum Conducted Output Power is defined as the total transmit power delivered to all antennas and antenna elements averaged across all symbols in the signaling alphabet when the transmitter is operating at its maximum power control level. Power must be summed across all antennas and antenna elements. The average must not include any time intervals during which the transmitter is off or is transmitting at a reduced power level. If multiple modes of operation are possible (e.g., alternative modulation methods), the maximum conducted output power is the highest total transmit power occurring in any mode.

Per RSS247 Issue 2 Section 5.4(d), for DTSs employing digital modulation techniques operating in the bands 902-928 MHz and 2400-2483.5 MHz, the maximum peak conducted output power shall not exceed 1W.

7.2 Test Standard

KDB 558074 D01v04 - Section 9.1.2 PKPM1 Peak Power Method (for signals with BW \leq 50MHz)

7.3 Test Procedures

Out power measurements were performed only when the EUT was transmitting at its maximum power control level using a broadband power meter with a pulse sensor. The pulse sensor employs a VBW = 50MHz so this method was only used for signals whose DTS bandwidth was less than or equal to 50MHz.

7.4 Test Setup Layout

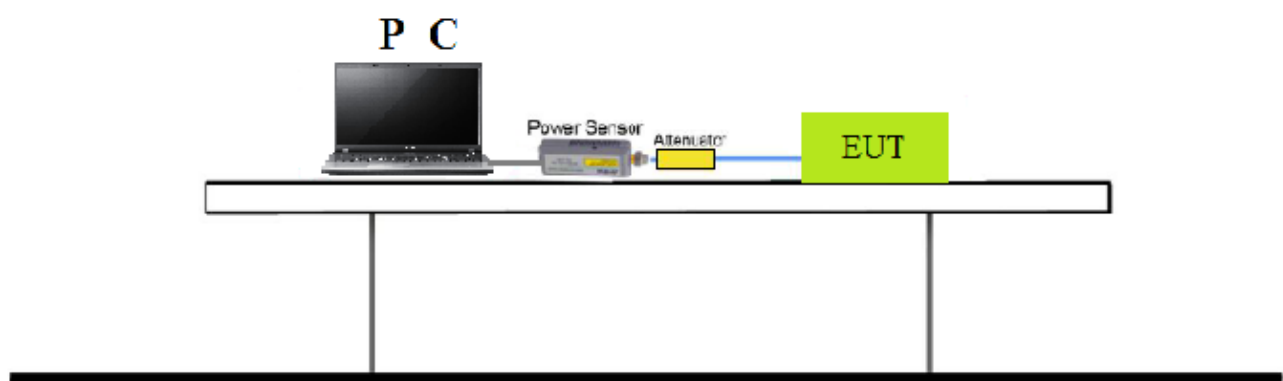



7.5 Test Result

For Peak Power :

Test Mode	Channel No.	Frequency (MHz)	Average Output Power (dBm)	Limit (dBm)	Result
802.11b	1	2412	22.37	30	Pass
	6	2437	23.41	30	Pass
	11	2462	20.96	30	Pass
802.11g	1	2412	23.16	30	Pass
	6	2437	23.23	30	Pass
	11	2462	23.19	30	Pass
802.11n(20MHz)	1	2412	23.13	30	Pass
	6	2437	23.24	30	Pass
	11	2462	23.06	30	Pass
802.11n(40MHz)	3	2422	23.12	30	Pass
	6	2437	23.18	30	Pass
	9	2452	22.62	30	Pass

For Average Power :

Test Mode	Channel No.	Frequency (MHz)	Average Output Power (dBm)	Limit (dBm)	Result
802.11b	1	2412	20.35	30	Pass
	6	2437	23.19	30	Pass
	11	2462	22.62	30	Pass
802.11g	1	2412	17.49	30	Pass
	6	2437	19.13	30	Pass
	11	2462	17.02	30	Pass
802.11n(20MHz)	1	2412	17.74	30	Pass
	6	2437	19.24	30	Pass
	11	2462	16.40	30	Pass
802.11n(40MHz)	3	2422	16.68	30	Pass
	6	2437	18.99	30	Pass
	9	2452	14.63	30	Pass



8. Power Spectral Density Measurement

8.1 Test Limit

According to FCC part15.247 - Section (e), for digitally modulated systems, the power spectral density conducted from the intentional radiator to the antenna shall not be greater than 8 dBm in any 3 kHz band during any time interval of continuous transmission. This power spectral density shall be determined in accordance with the provisions of paragraph (b) of this section. The same method of determining the conducted output power shall be used to determine the power spectral density.

8.2 Test Standard

KDB 558074 D01v04- Section 10.2 Method PKPSD

8.3 Test Procedures

1. Set RBW=3kHz
2. Set RBW=10kHz
3. Span = 1.5 times the DTS channel bandwidth
4. Detector=Peak
5. Trace mode=Max hold
6. Sweep time=Auto couple
7. Allow the trace to stabilize
8. Analyzer was set to the center frequency of the DTS channel under investigation.

8.4 Test Setup Layout

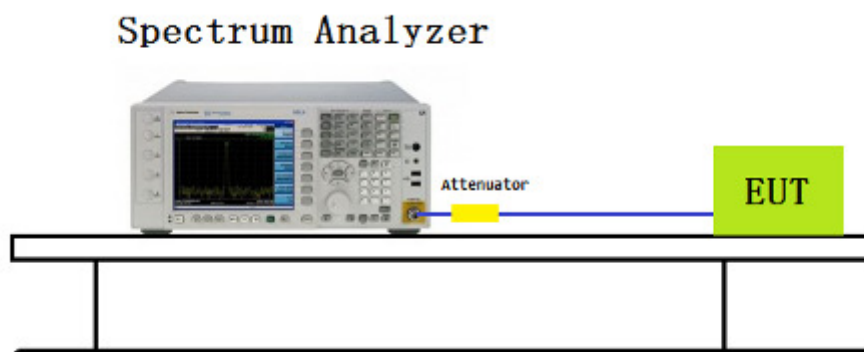



8.5 Test Result

Test Mode	Channel No.	Frequency(MHz)	Power Spectral Density (dBm/3kHz)	Limit (dBm/3kHz)	Result
802.11b	1	2412	-8.359	8	Pass
	6	2437	-7.130	8	Pass
	11	2462	-10.402	8	Pass
802.11g	1	2412	-6.593	8	Pass
	6	2437	-7.202	8	Pass
	11	2462	-9.956	8	Pass
802.11n(20M Hz)	1	2412	-6.466	8	Pass
	6	2437	-6.994	8	Pass
	11	2462	-9.874	8	Pass
802.11n(40M Hz)	3	2422	-6.367	8	Pass
	6	2437	-7.249	8	Pass
	9	2452	-9.685	8	Pass



Test Item	Power Spectral Density
Test Mode	Mode 1: Transmit by 802.11b

Channel 1 (2412MHz)

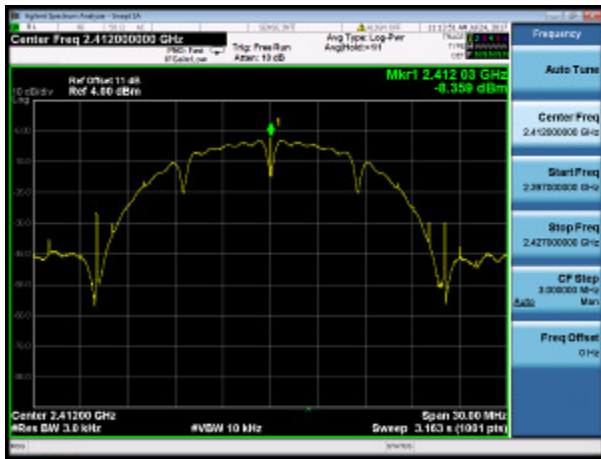

Channel 6 (2437MHz)



Channel 11 (2462MHz)





Test Item	Power Spectral Density
Test Mode	Mode 2: Transmit by 802.11g

Channel 1 (2412MHz)

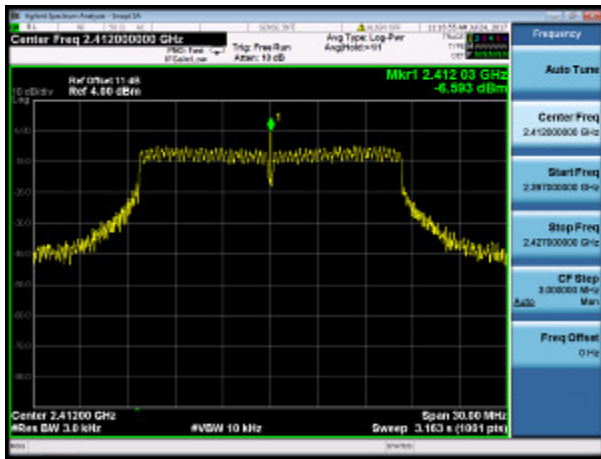

Channel 6 (2437MHz)

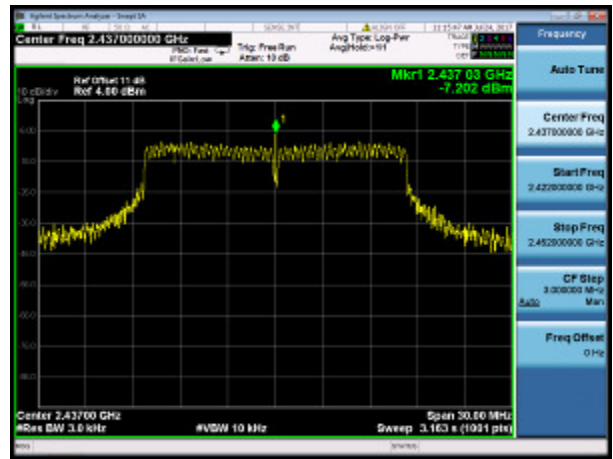

Channel 11 (2462MHz)

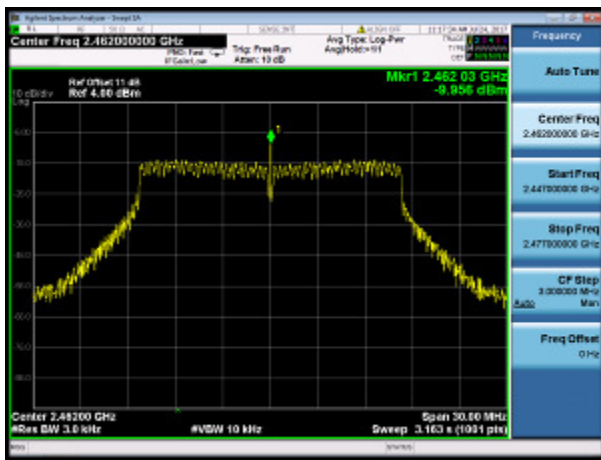



Test Item	Power Spectral Density
Test Mode	Mode 3: Transmit by 802.11n(20MHz)

Channel 1 (2412MHz)

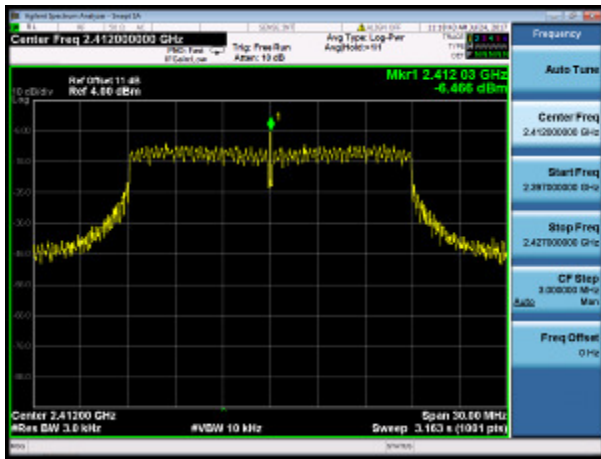

Channel 6 (2437MHz)

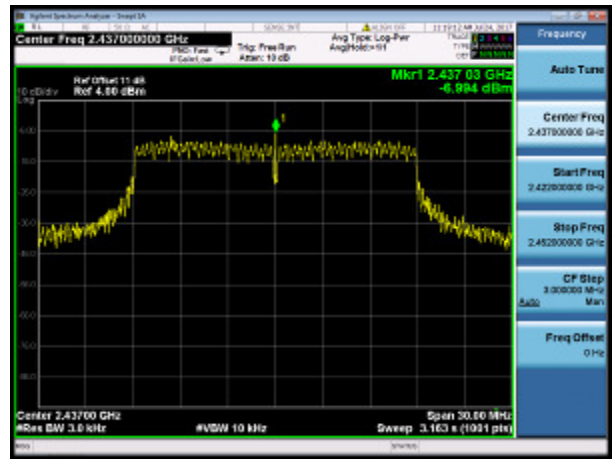

Channel 11 (2462MHz)

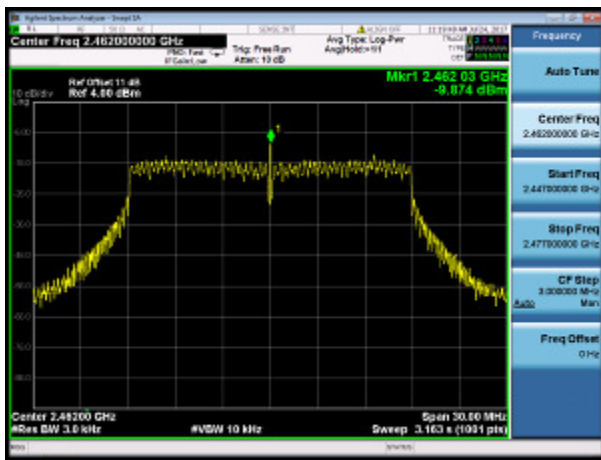



Test Item	Power Spectral Density
Test Mode	Mode 4: Transmit by 802.11n(40MHz)

Channel 3 (2422MHz)

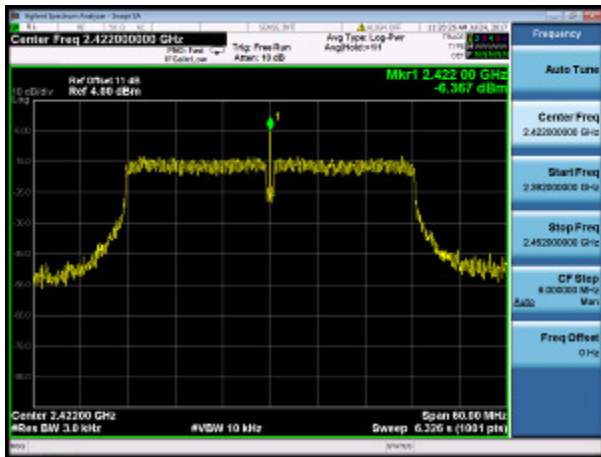

Channel 6 (2437MHz)

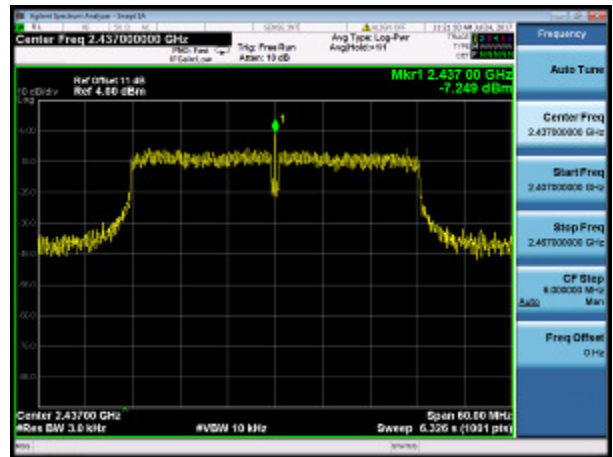

Channel 9 (2452MHz)

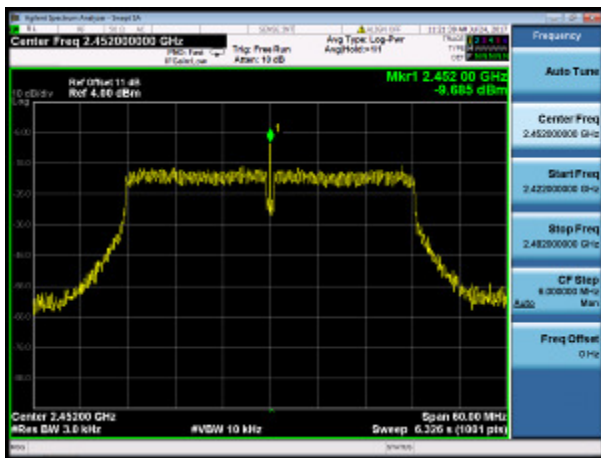



9. Conducted Band Edge and Out-of-Band Emissions Measurement

9.1 Test Limit

According to FCC part 15.247(d) , in any 100 kHz bandwidth outside the frequency band in which the spread spectrum or digitally modulated intentional radiator is operating, the radio frequency power that is produced by the intentional radiator shall be at least 20 dB below that in the 100 kHz bandwidth within the band that contains the highest level of the desired power, based on either an RF conducted or a radiated measurement, provided the transmitter demonstrates compliance with the peak conducted or a radiated measurement, provided the transmitter demonstrates compliance with the peak conducted power limits. If the transmitter complies with the conducted power limits based on the use of RMS averaging over a time interval, the attenuation required under this paragraph shall be 30 dB instead of 20 dB. Attenuation below the general limits specified in Section 15.209(a) of FCC part 15 is not required.

9.2 Test Standard

KDB 558074 D01v04 - Section 11.2 & Section 11.3



9.3 Test Procedures

Reference level measurement:

1. Set the RBW = 100 kHz
2. Set the VBW $\geq 3 \times$ RBW
3. Set the span to ≥ 1.5 times the DTS bandwidth
4. Detector = peak
5. Trace mode = max hold
6. Sweep time = auto couple
7. Allow trace to fully stabilize
8. Set instrument center frequency to DTS channel center frequency

Emission level measurement:

1. RBW = 100kHz
2. VBW = 300kHz
3. Detector = Peak
4. Trace mode = max hold
5. Sweep time = auto couple
6. The trace was allowed to stabilize
7. Set the center frequency and span to encompass frequency range to be measured

9.4 Test Setup Layout

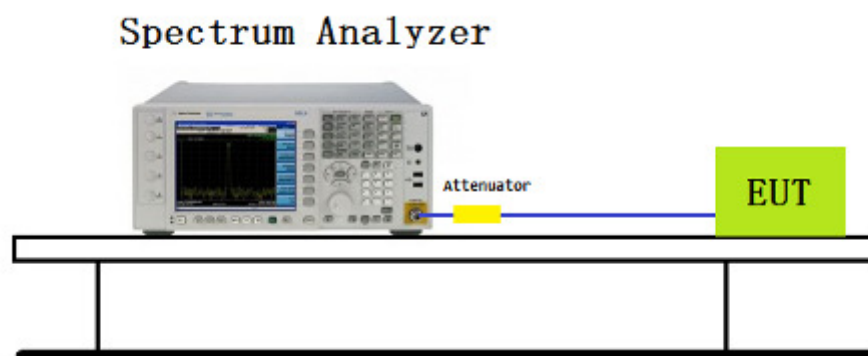



9.5 Test Result

Test Mode	Channel No.	Frequency (MHz)	Limit	Result
802.11b	1	2412	20dBc	Pass
	6	2437	20dBc	Pass
	11	2462	20dBc	Pass
802.11g	1	2412	20dBc	Pass
	6	2437	20dBc	Pass
	11	2462	20dBc	Pass
802.11n(20MHz)	1	2412	20dBc	Pass
	6	2437	20dBc	Pass
	11	2462	20dBc	Pass
802.11n(40MHz)	3	2422	20dBc	Pass
	6	2437	20dBc	Pass
	9	2452	20dBc	Pass



Test Item	:	Conducted Band Edge and Out-of-Band Emissions
Test Mode	:	Mode 1: Transmit by 802.11b

Mode 1: Transmit by 802.11b (2412MHz)

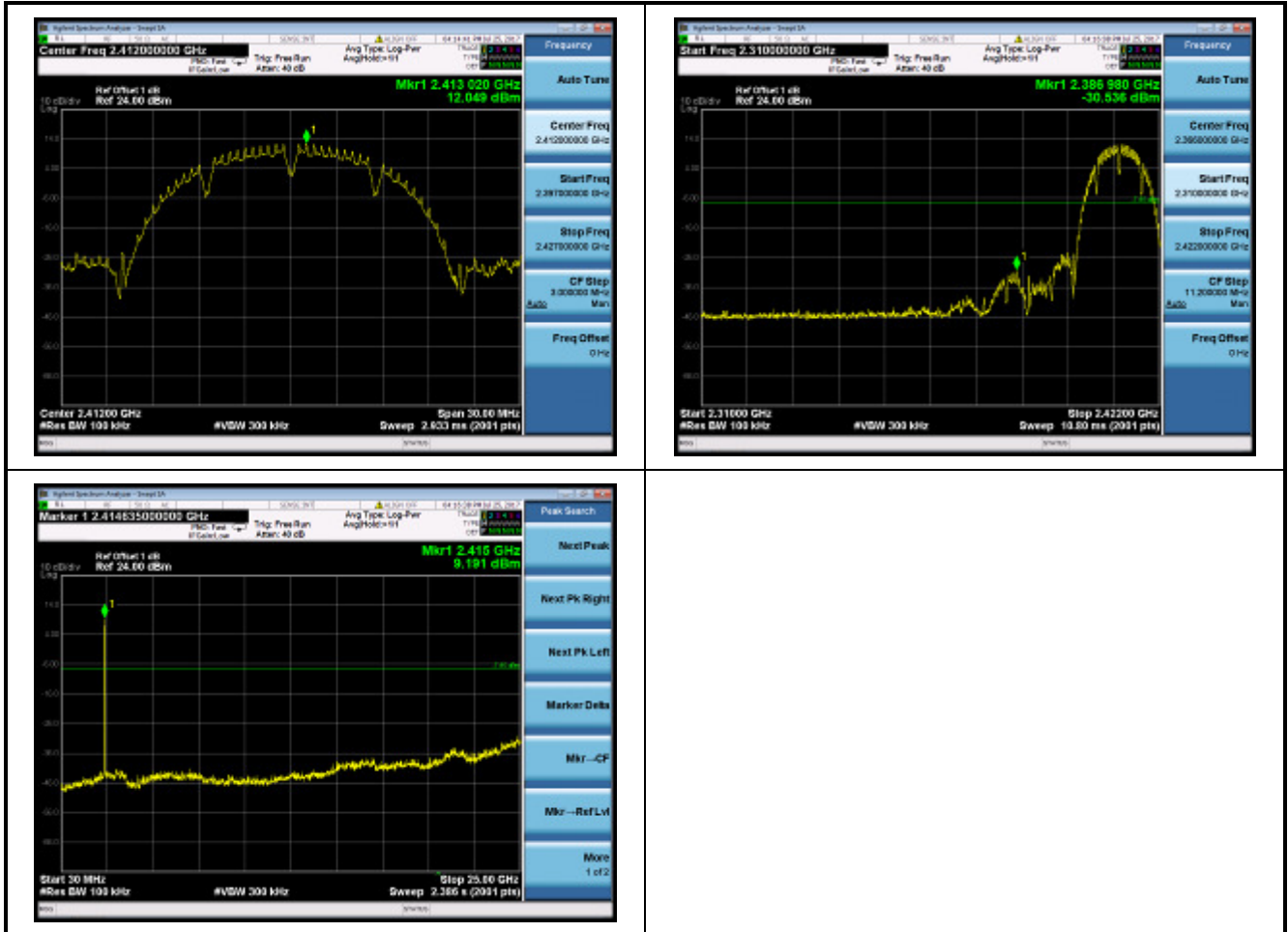



Mode 1: Transmit by 802.11b (2437MHz)

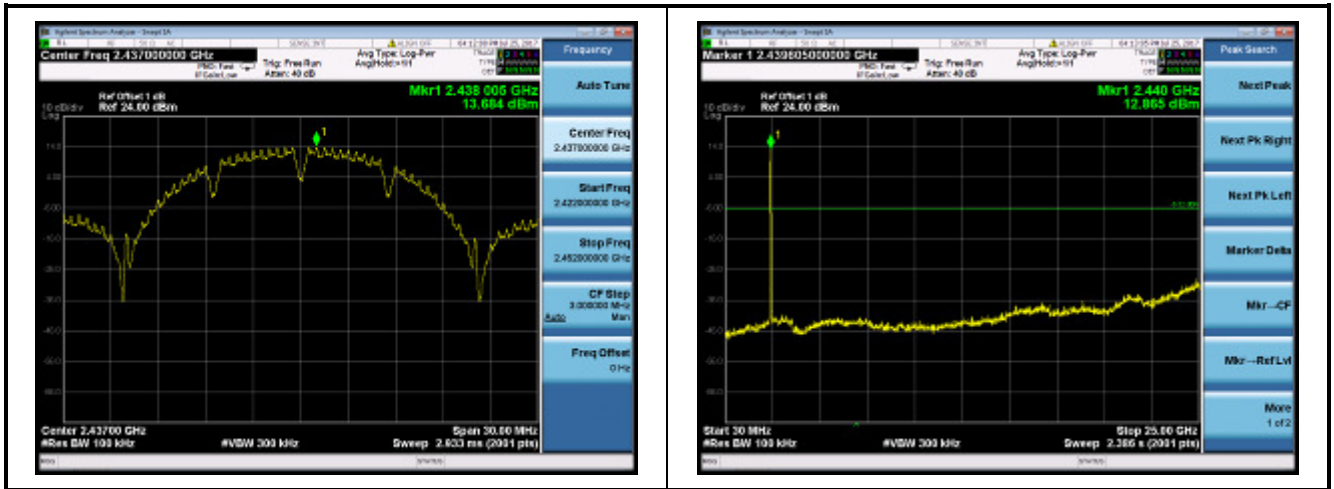

Mode 1: Transmit by 802.11b (2462MHz)

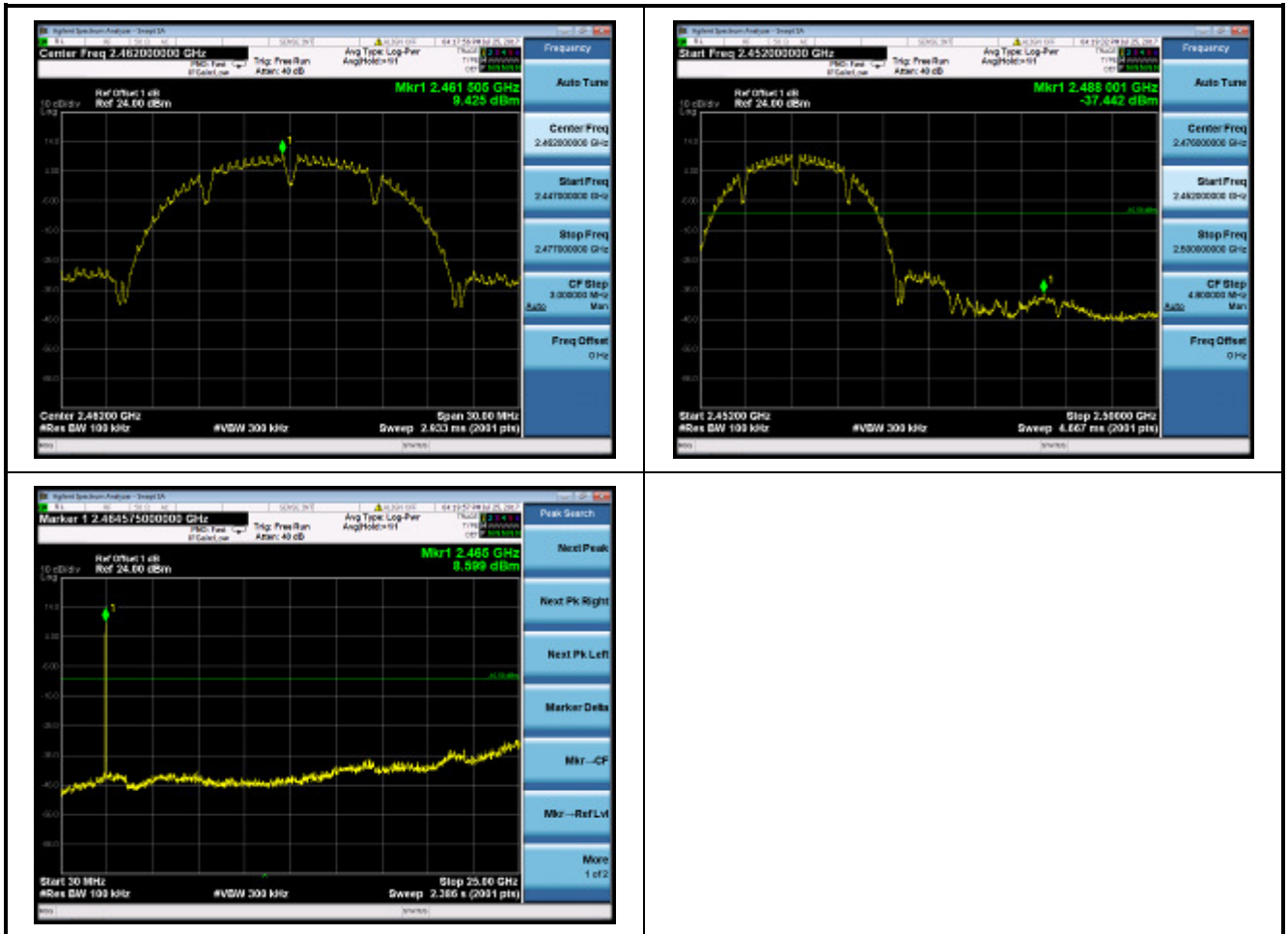



Test Item	:	Band-edge Compliance & Conducted Spurious Emissions
Test Mode	:	Mode 2: Transmit by 802.11g

Mode 2: Transmit by 802.11g (2412MHz)

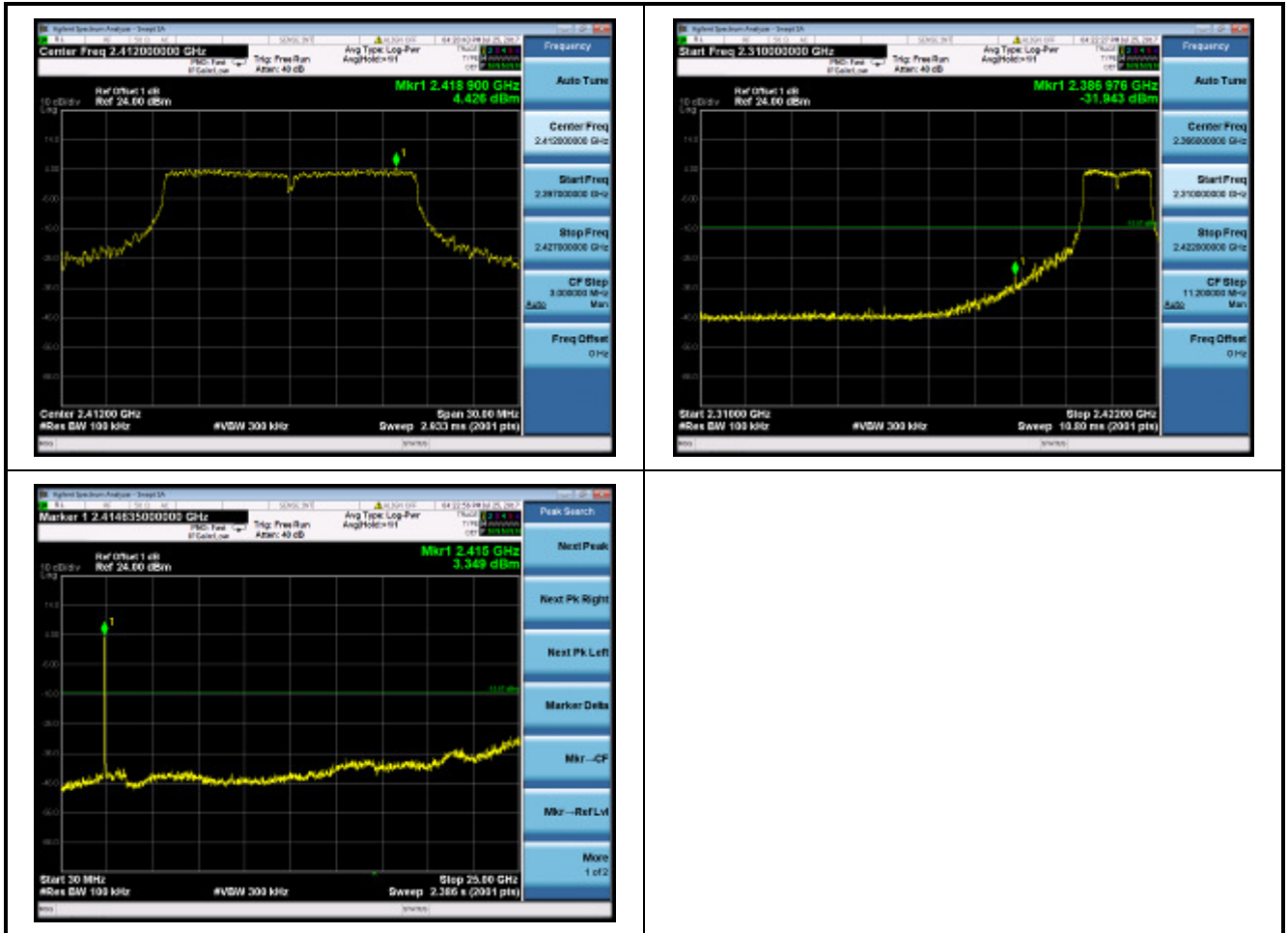



Mode 2: Transmit by 802.11g (2437MHz)

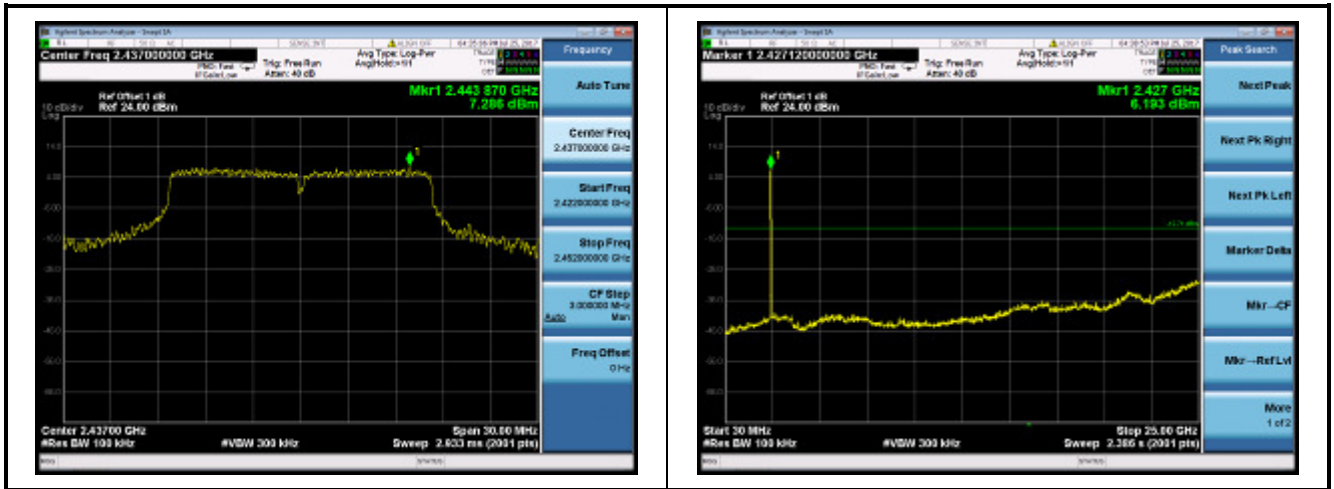

Mode 2: Transmit by 802.11g (2462MHz)

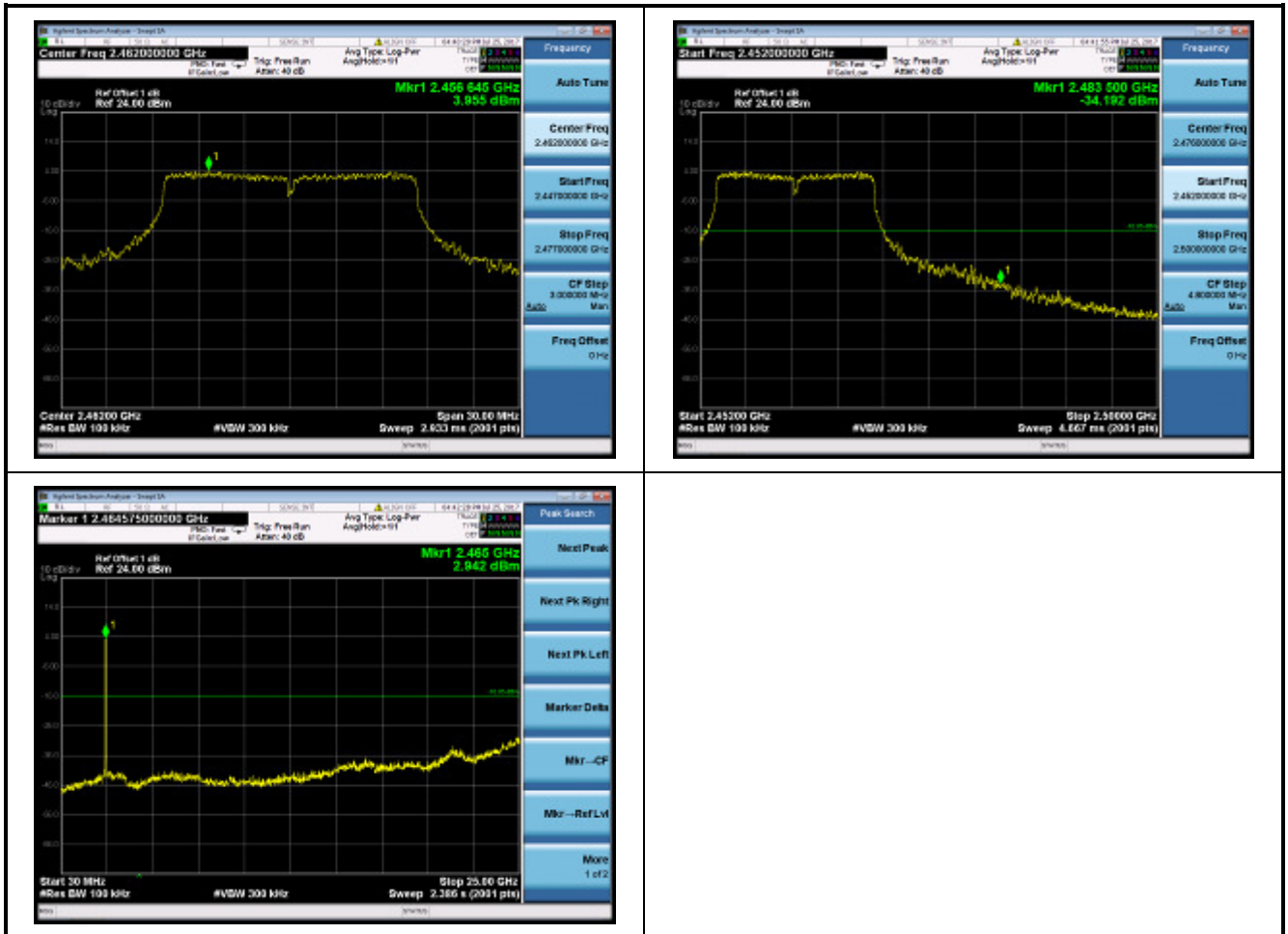



Test Item	:	Band-edge Compliance & Conducted Spurious Emissions
Test Mode	:	Mode 3: Transmit by 802.11n(20MHz)

Mode 3: Transmit by 802.11n(20MHz) (2412MHz)

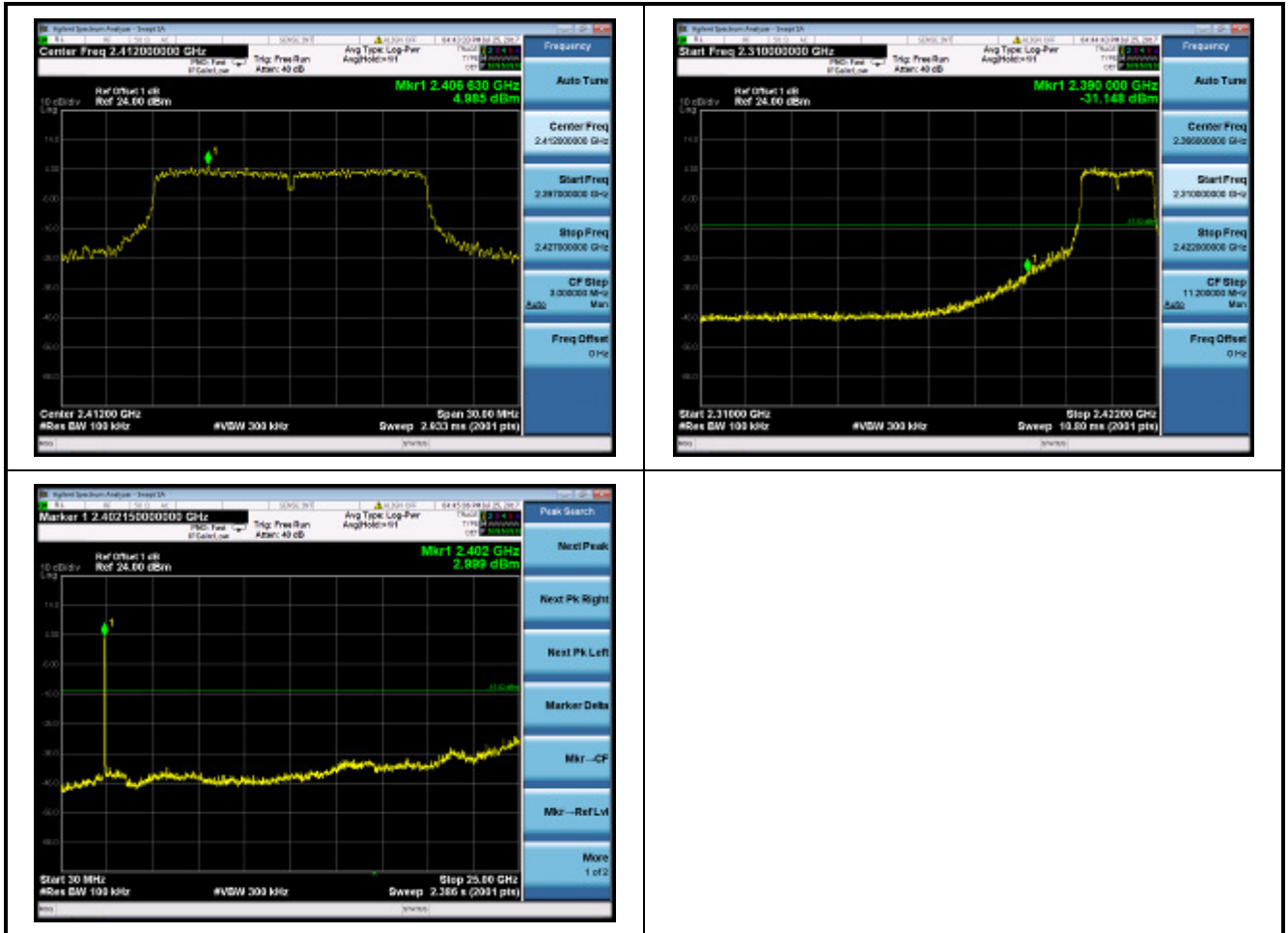



Mode 3: Transmit by 802.11n(20MHz) (2437MHz)

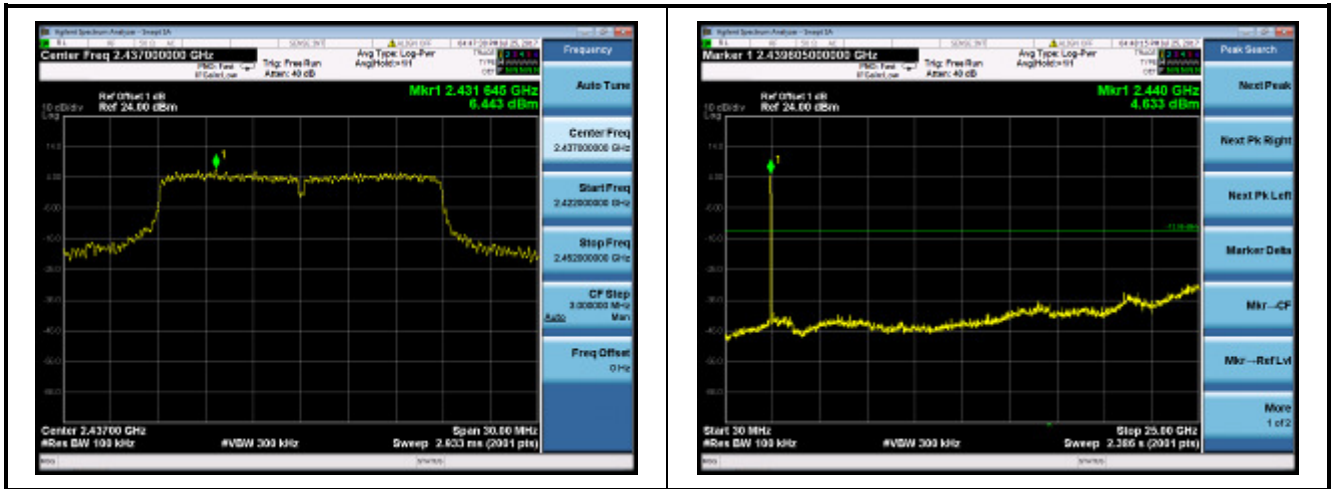

Mode 3: Transmit by 802.11n(20MHz) (2462MHz)

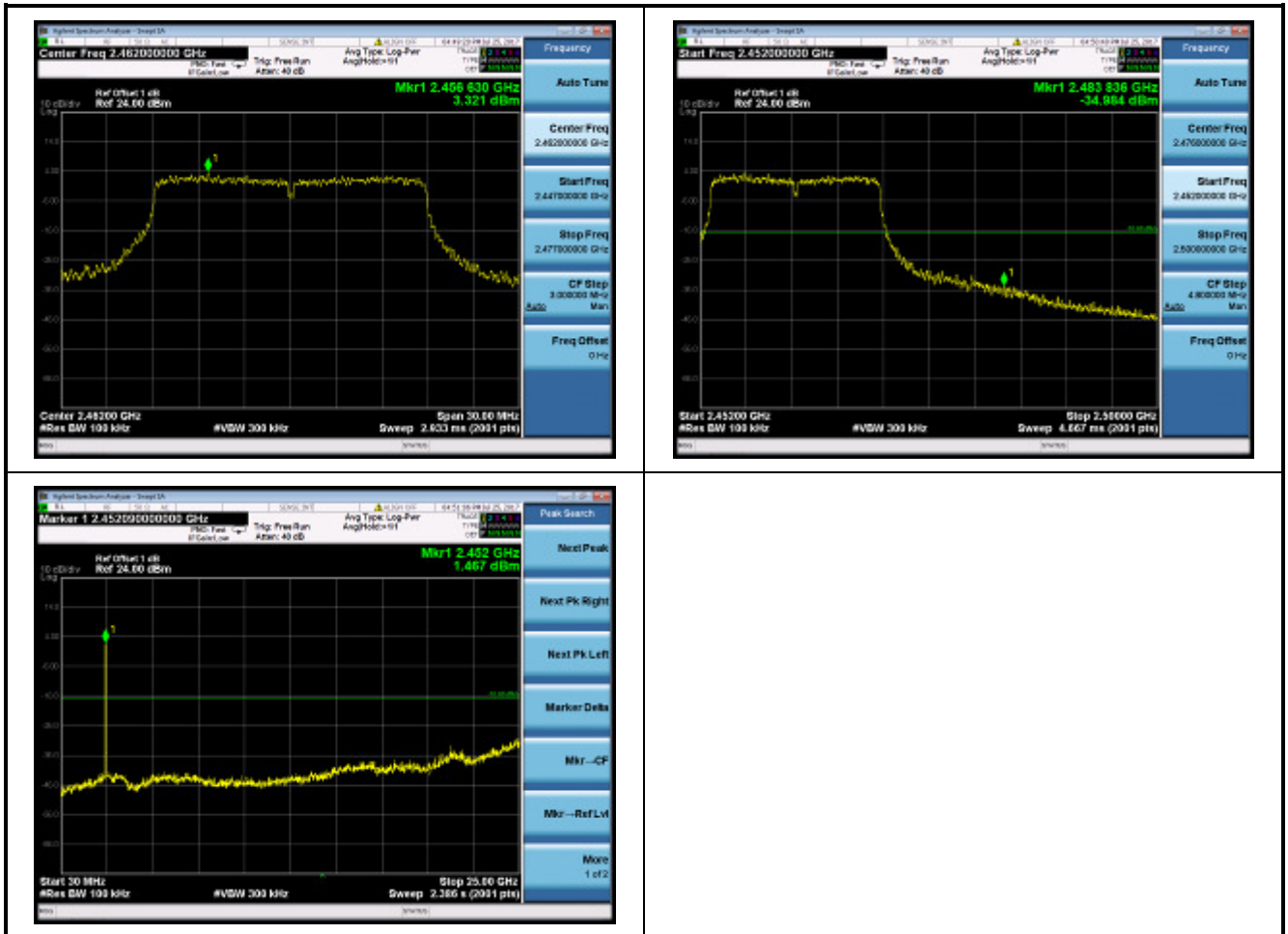



Test Item	:	Band-edge Compliance & Conducted Spurious Emissions
Test Mode	:	Mode 4: Transmit by 802.11n(40MHz)

Mode 4: Transmit by 802.11n(40MHz) (2422MHz)

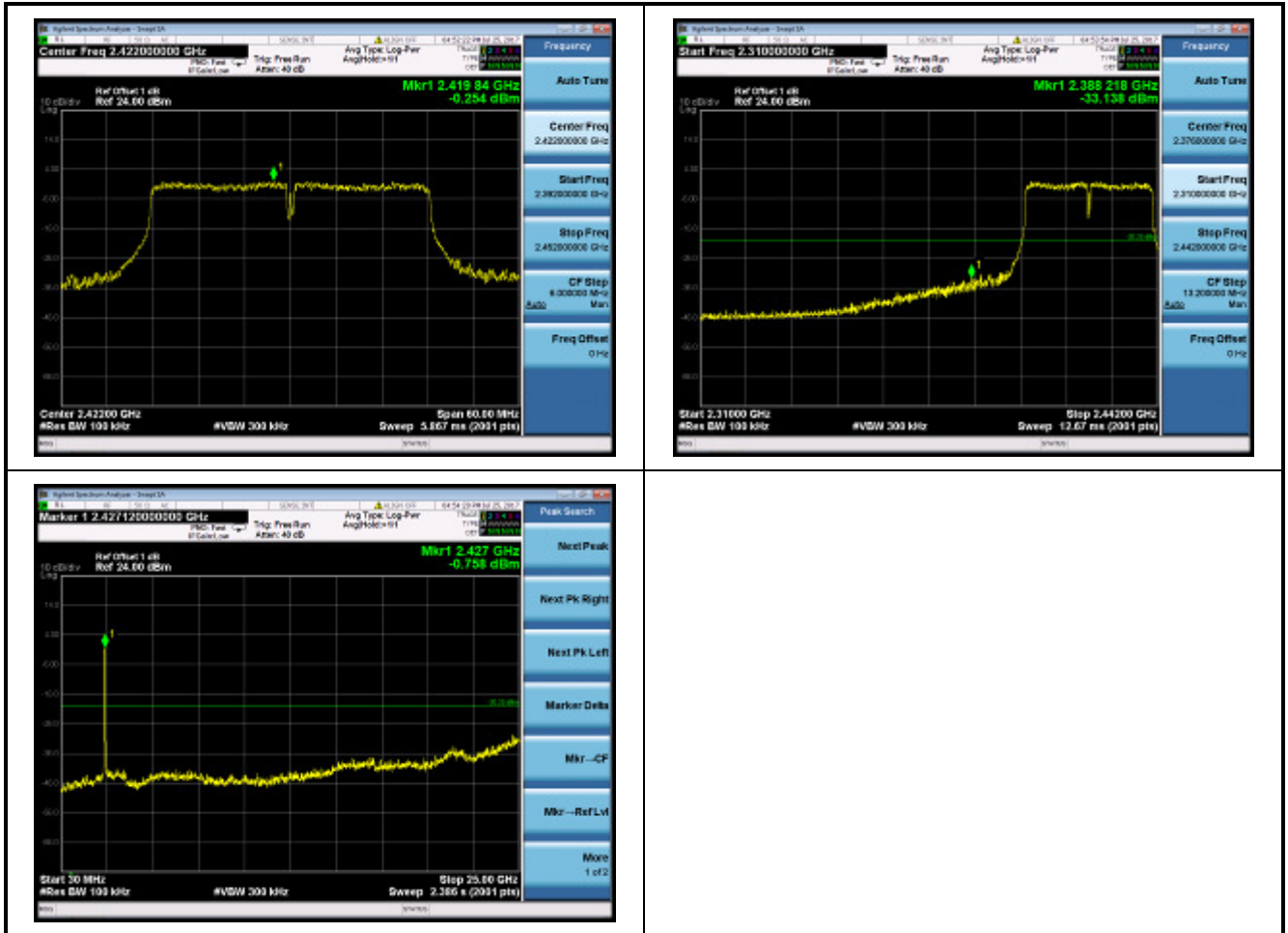



Mode 4: Transmit by 802.11n(40MHz) (2437MHz)

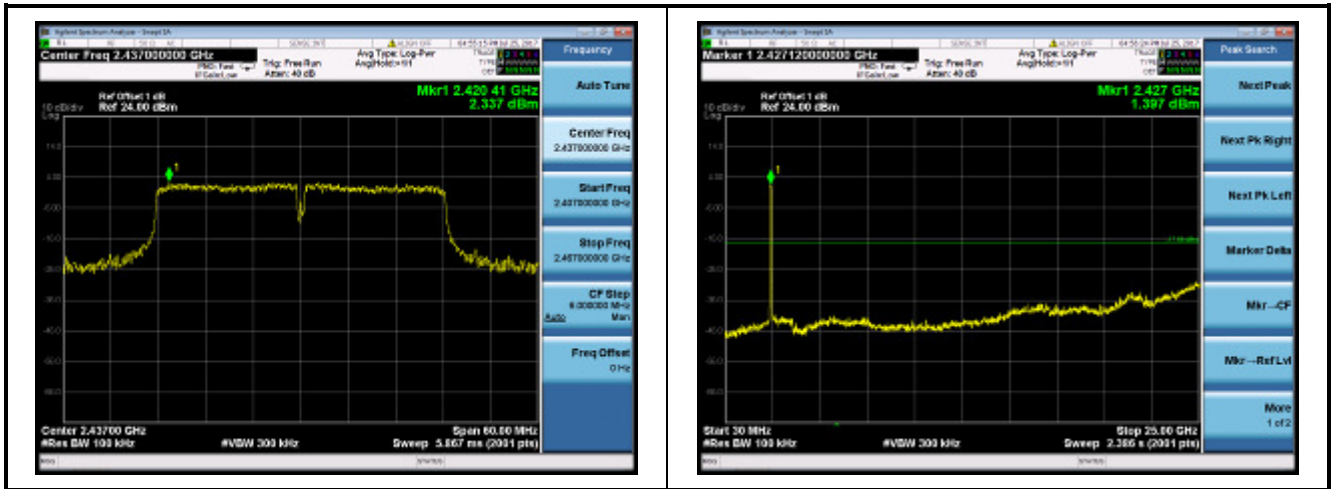

Mode 4: Transmit by 802.11n(40MHz) (2452MHz)

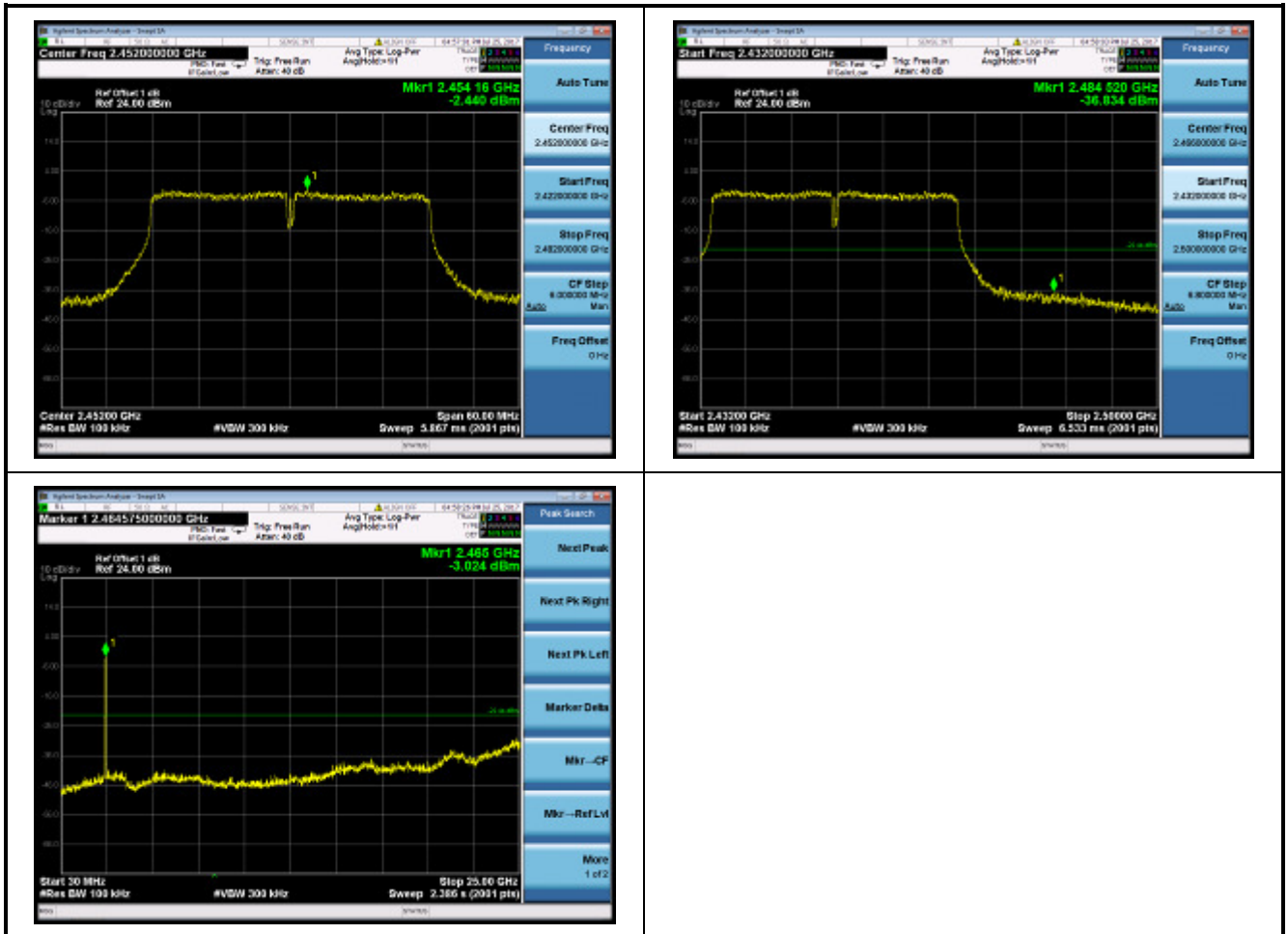



10. Radiated Emission Band Edge Measurement

10.1 Test Limit

Radiated emissions which fall in the restricted bands, as defined in Section 15.205(a) of FCC part 15, must also comply with the radiated emission limits specified in Section 15.209(a) of FCC part 15.

10.2 Test Standard

ANSI C63.10-2013 Section 6.10.5

10.3 Test Procedure

Peak Field Strength Measurements:

Analyzer center frequency was set to the frequency of the radiated spurious emission of interest

7. RBW=As specified in Table 1
8. VBW=3×RBW
9. Detector=Peak
10. Trace mode=Max hold
11. Sweep time=Auto couple
12. Allow the trace to stabilize

Table 1-RBW as a function of frequency

Frequency	RBW
9 ~ 150kHz	200 ~ 300Hz
0.15 ~ 30MHz	9 ~ 10kHz
30 ~ 1000MHz	100 ~ 120kHz
> 1000MHz	1MHz



AVE Field Strength Measurements:

Analyzer center frequency was set to the frequency of the radiated spurious emission of interest

- 7. RBW= 1MHz
- 8. VBW \geq 1/T
- 9. Detector=Peak
- 10. Trace mode=Max hold
- 11. Sweep time=Auto couple
- 12. Allow max hold to run for at least 50 times(1/duty cycle) trace

Do as an alternative, the instrument may be set to linear detector mode. Ensure that video filtering is applied in linear voltage domain (rather than in a log or dB domain). Some instruments require linear display mode in order to accomplish this. Others have a setting for Average-VBW Type, which can be set to "Voltage" regardless of the display mode

10.4 Test Setup Layout

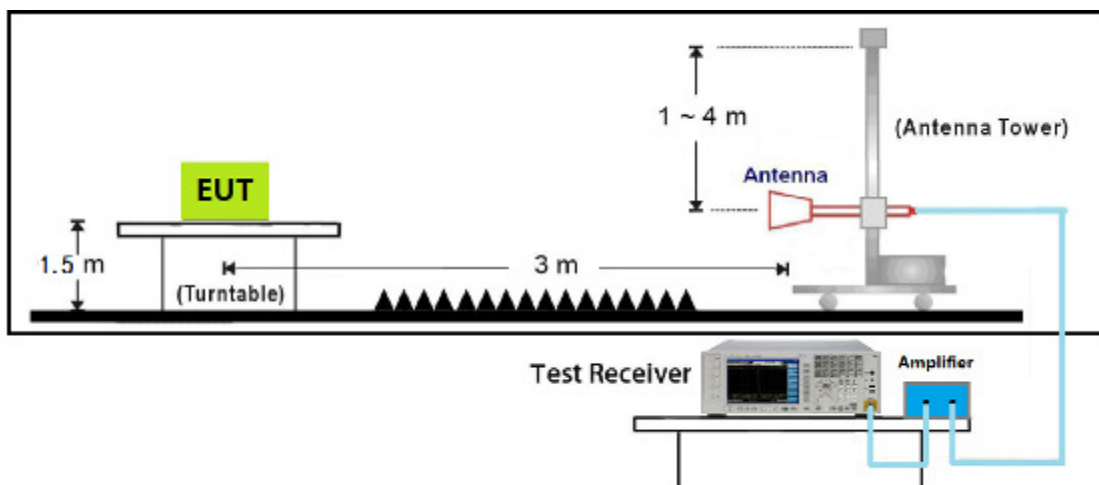



10.5 Test Result

Site:AC102	Time: 2017/07/24 - 18:27
Limit: FCC_Part15.209_RE(3m)	Margin: 0
Probe: N/A	Polarity: Horizontal
EUT:IP CAMERA	Power: AC 120V/60Hz
Note: Mode:Transmit 802.11b at 2412MHz	

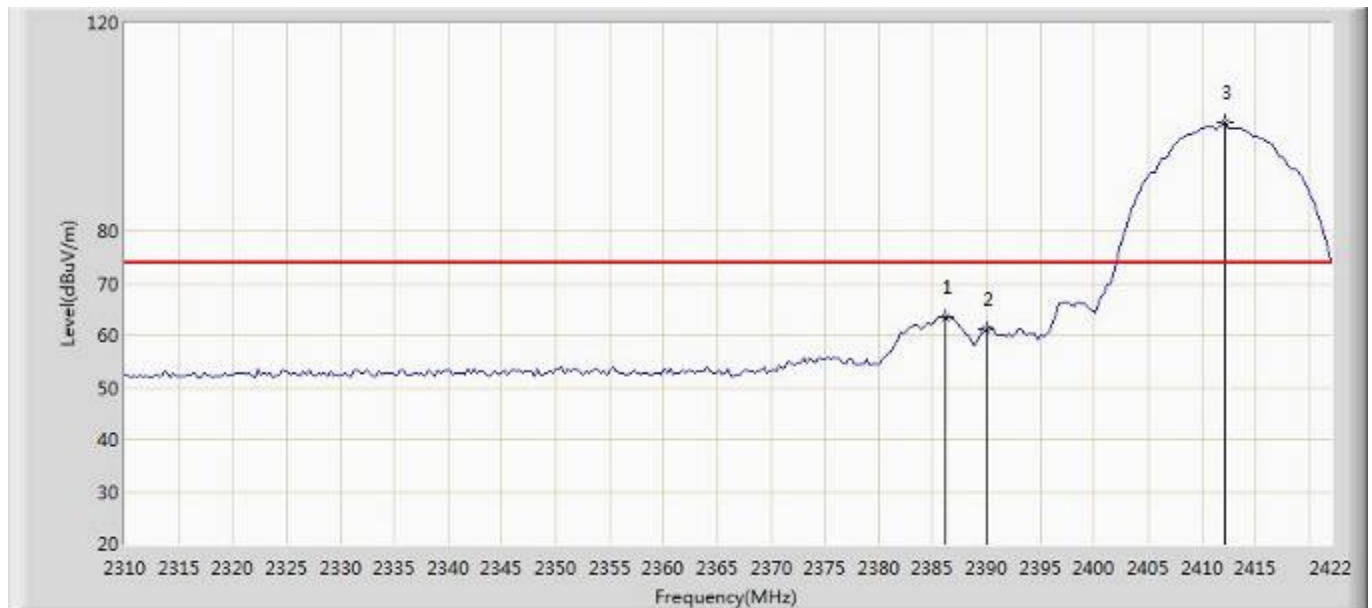

No	Mark	Frequency (MHz)	Measure Level (dBuV/m)	Reading Level (dBuV)	Over Limit (dB)	Limit (dBuV/m)	Factor (dB)	Type
1		2386.160	63.560	65.816	-10.440	74.000	-2.256	PK
2		2390.000	61.244	63.485	-12.756	74.000	-2.241	PK
3	*	2412.200	100.728	102.886	N/A	N/A	-2.158	PK



Site:AC102	Time: 2017/07/24 - 19:22
Limit: FCC_Part15.209_RE(3m)	Margin: 0
Probe: N/A	Polarity: Horizontal
EUT:IP CAMERA	Power: AC 120V/60Hz
Note: Mode:Transmit 802.11b at 2412MHz	

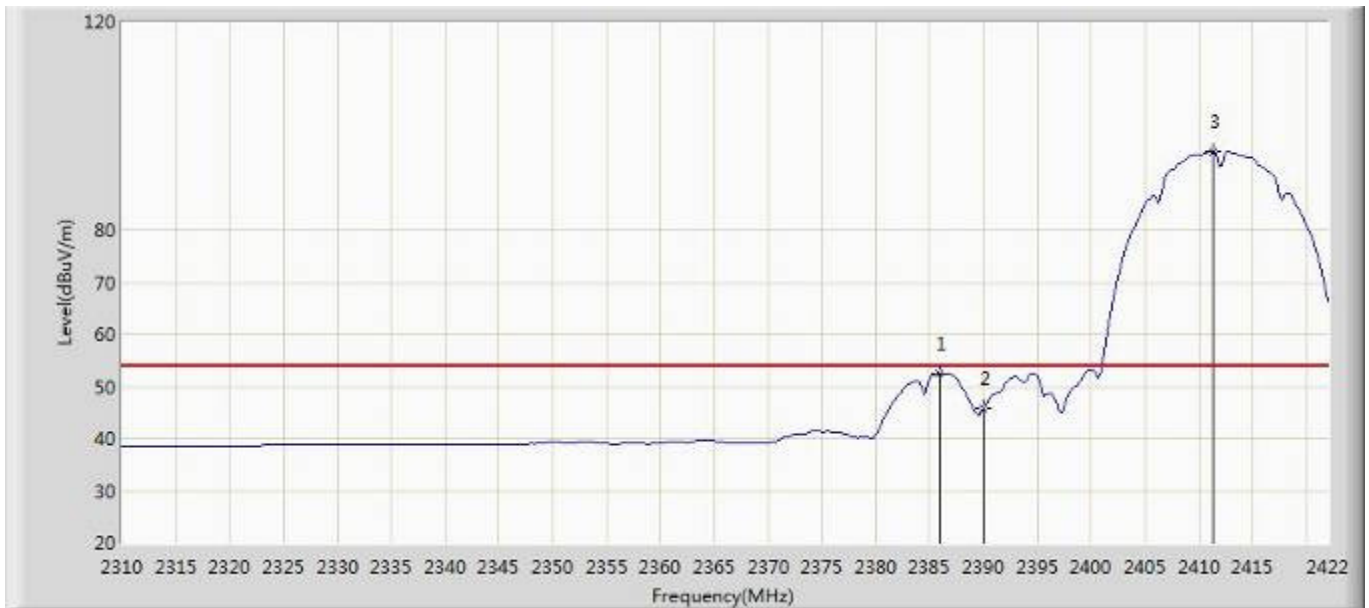

No	Mark	Frequency (MHz)	Measure Level (dBuV/m)	Reading Level (dBuV)	Over Limit (dB)	Limit (dBuV/m)	Factor (dB)	Type
1		2385.880	52.586	54.843	-1.414	54.000	-2.257	AV
2		2390.000	45.798	48.039	-8.202	54.000	-2.241	AV
3	*	2411.360	95.149	97.311	N/A	N/A	-2.162	AV



Site:AC102	Time: 2017/07/24 - 19:26
Limit: FCC_Part15.209_RE(3m)	Margin: 0
Probe: N/A	Polarity: Vertical
EUT:IP CAMERA	Power: AC 120V/60Hz
Note: Mode:Transmit 802.11b at 2412MHz	

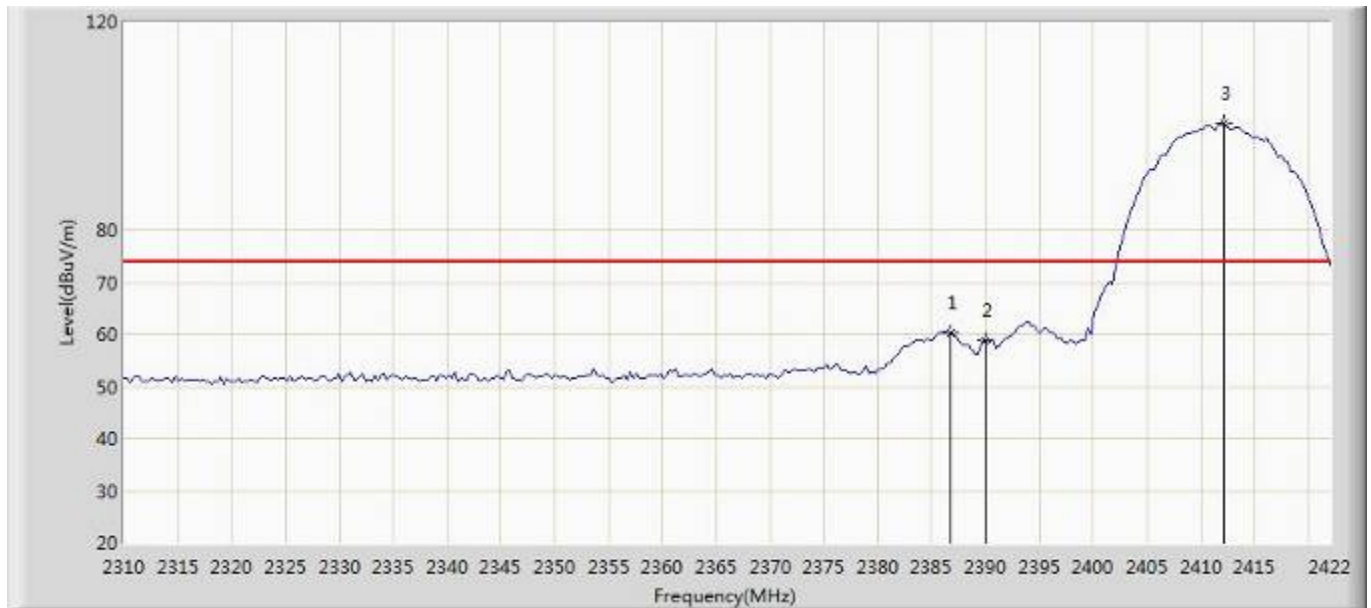

No	Mark	Frequency (MHz)	Measure Level (dBuV/m)	Reading Level (dBuV)	Over Limit (dB)	Limit (dBuV/m)	Factor (dB)	Type
1		2386.720	60.283	62.536	-13.717	74.000	-2.253	PK
2		2390.000	58.730	60.971	-15.270	74.000	-2.241	PK
3	*	2412.200	100.494	102.652	N/A	N/A	-2.158	PK



Site:AC102	Time: 2017/07/24 - 19:30
Limit: FCC_Part15.209_RE(3m)	Margin: 0
Probe: N/A	Polarity: Vertical
EUT:IP CAMERA	Power: AC 120V/60Hz
Note: Mode:Transmit 802.11b at 2412MHz	

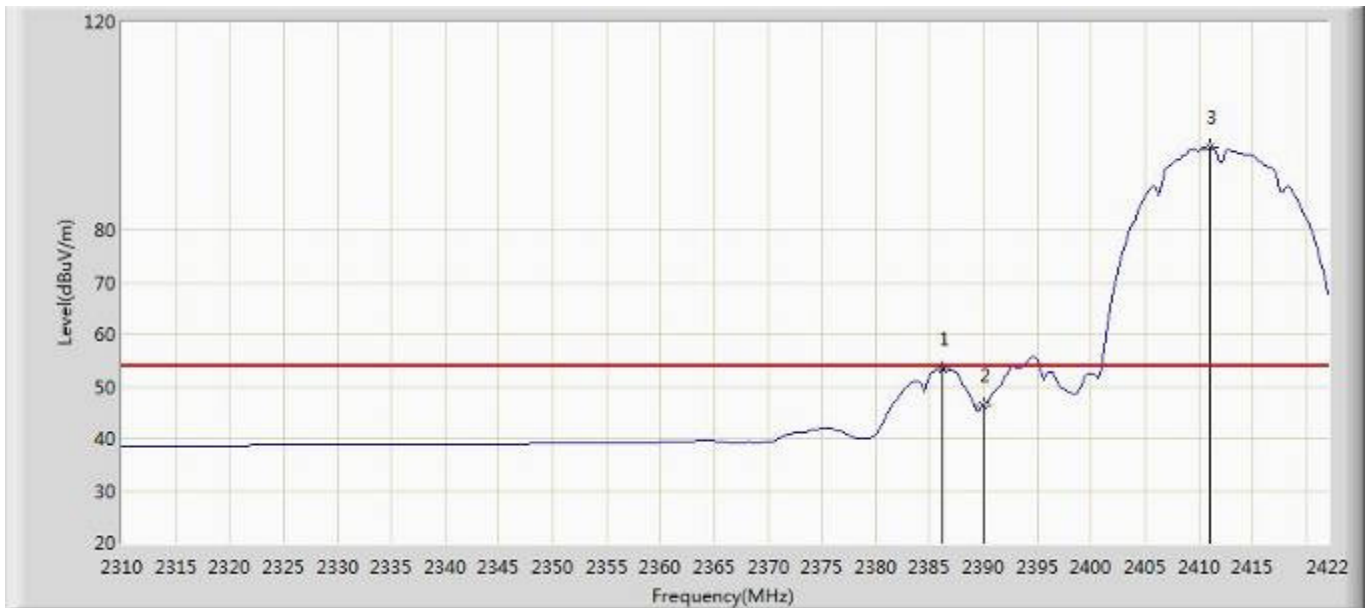

No	Mark	Frequency (MHz)	Measure Level (dBuV/m)	Reading Level (dBuV)	Over Limit (dB)	Limit (dBuV/m)	Factor (dB)	Type
1		2386.160	53.361	55.617	-0.639	54.000	-2.256	AV
2		2390.000	46.465	48.706	-7.535	54.000	-2.241	AV
3	*	2411.080	95.950	98.113	N/A	N/A	-2.163	AV



Site:AC102	Time: 2017/07/24 - 19:34
Limit: FCC_Part15.209_RE(3m)	Margin: 0
Probe: N/A	Polarity: Vertical
EUT:IP CAMERA	Power: AC 120V/60Hz
Note: Mode:Transmit 802.11b at 2462MHz	



No	Mark	Frequency (MHz)	Measure Level (dBuV/m)	Reading Level (dBuV)	Over Limit (dB)	Limit (dBuV/m)	Factor (dB)	Type
1	*	2461.960	102.941	104.913	N/A	N/A	-1.972	PK
2		2483.500	56.516	58.408	-17.484	74.000	-1.892	PK
3		2487.760	59.291	61.167	-14.709	74.000	-1.876	PK



Site:AC102	Time: 2017/07/24 - 19:39
Limit: FCC_Part15.209_RE(3m)	Margin: 0
Probe: N/A	Polarity: Vertical
EUT:IP CAMERA	Power: AC 120V/60Hz
Note: Mode:Transmit 802.11b at 2462MHz	



No	Mark	Frequency (MHz)	Measure Level (dBuV/m)	Reading Level (dBuV)	Over Limit (dB)	Limit (dBuV/m)	Factor (dB)	Type
1	*	2461.360	98.740	100.714	N/A	N/A	-1.974	AV
2		2483.500	47.353	49.245	-6.647	54.000	-1.892	AV
3		2488.000	51.238	53.113	-2.762	54.000	-1.875	AV



Site:AC102	Time: 2017/07/24 - 19:43
Limit: FCC_Part15.209_RE(3m)	Margin: 0
Probe: N/A	Polarity: Horizontal
EUT:IP CAMERA	Power: AC 120V/60Hz
Note: Mode:Transmit 802.11b at 2462MHz	



No	Mark	Frequency (MHz)	Measure Level (dBuV/m)	Reading Level (dBuV)	Over Limit (dB)	Limit (dBuV/m)	Factor (dB)	Type
1	*	2461.960	98.683	100.655	N/A	N/A	-1.972	PK
2		2483.500	56.408	58.300	-17.592	74.000	-1.892	PK
3		2487.640	57.909	59.785	-16.091	74.000	-1.876	PK



Site:AC102	Time: 2017/07/24 - 19:46
Limit: FCC_Part15.209_RE(3m)	Margin: 0
Probe: N/A	Polarity: Horizontal
EUT:IP CAMERA	Power: AC 120V/60Hz
Note: Mode:Transmit 802.11b at 2462MHz	



No	Mark	Frequency (MHz)	Measure Level (dBuV/m)	Reading Level (dBuV)	Over Limit (dB)	Limit (dBuV/m)	Factor (dB)	Type
1	*	2461.120	93.863	95.838	N/A	N/A	-1.975	AV
2		2483.500	44.990	46.882	-9.010	54.000	-1.892	AV
3		2487.880	47.965	49.841	-6.035	54.000	-1.876	AV



Site:AC102	Time: 2017/07/24 - 19:47
Limit: FCC_Part15.209_RE(3m)	Margin: 0
Probe: N/A	Polarity: Horizontal
EUT:IP CAMERA	Power: AC 120V/60Hz
Note: Mode:Transmit 802.11g at 2412MHz	



No	Mark	Frequency (MHz)	Measure Level (dBuV/m)	Reading Level (dBuV)	Over Limit (dB)	Limit (dBuV/m)	Factor (dB)	Type
1		2388.960	66.830	69.075	-7.170	74.000	-2.245	PK
2		2390.000	66.093	68.334	-7.907	74.000	-2.241	PK
3	*	2419.200	98.590	100.722	N/A	N/A	-2.132	PK



Site:AC102	Time: 2017/07/24 - 19:53
Limit: FCC_Part15.209_RE(3m)	Margin: 0
Probe: N/A	Polarity: Horizontal
EUT:IP CAMERA	Power: AC 120V/60Hz
Note: Mode:Transmit 802.11g at 2412MHz	

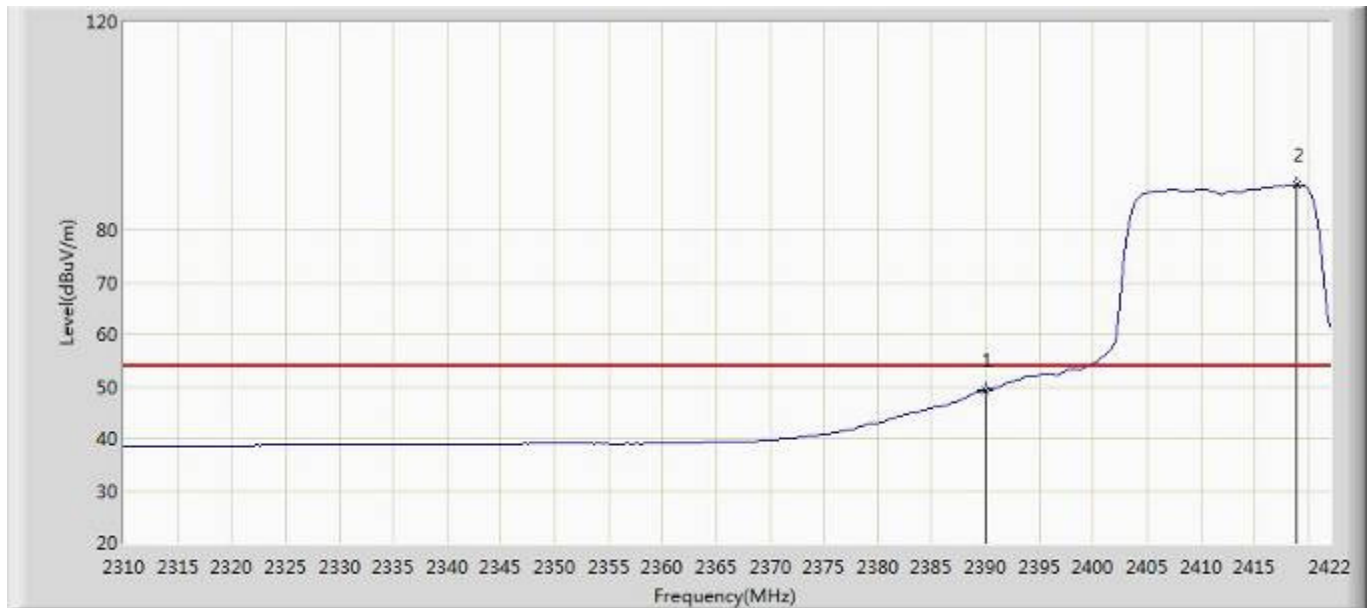

No	Mark	Frequency (MHz)	Measure Level (dBuV/m)	Reading Level (dBuV)	Over Limit (dB)	Limit (dBuV/m)	Factor (dB)	Type
1		2390.000	49.345	51.586	-4.655	54.000	-2.241	AV
2	*	2418.920	88.788	90.921	N/A	N/A	-2.133	AV



Site:AC102	Time: 2017/07/24 - 19:53
Limit: FCC_Part15.209_RE(3m)	Margin: 0
Probe: N/A	Polarity: Vertical
EUT:IP CAMERA	Power: AC 120V/60Hz
Note: Mode:Transmit 802.11g at 2412MHz	



No	Mark	Frequency (MHz)	Measure Level (dBuV/m)	Reading Level (dBuV)	Over Limit (dB)	Limit (dBuV/m)	Factor (dB)	Type
1		2388.960	69.948	72.193	-4.052	74.000	-2.245	PK
2		2390.000	68.956	71.197	-5.044	74.000	-2.241	PK
3	*	2417.800	100.621	102.758	N/A	N/A	-2.137	PK



Site:AC102	Time: 2017/07/24 - 19:58
Limit: FCC_Part15.209_RE(3m)	Margin: 0
Probe: N/A	Polarity: Vertical
EUT:IP CAMERA	Power: AC 120V/60Hz
Note: Mode:Transmit 802.11g at 2412MHz	

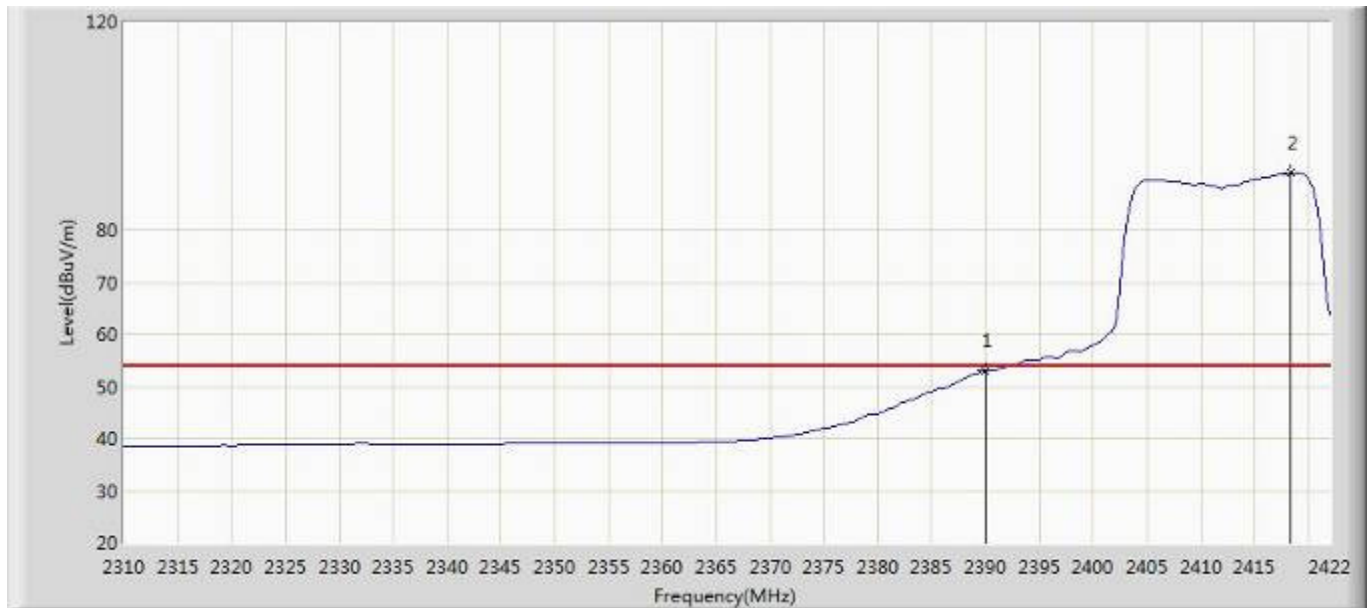

No	Mark	Frequency (MHz)	Measure Level (dBuV/m)	Reading Level (dBuV)	Over Limit (dB)	Limit (dBuV/m)	Factor (dB)	Type
1		2390.000	53.005	55.246	-0.995	54.000	-2.241	AV
2	*	2418.360	90.990	93.125	N/A	N/A	-2.135	AV



Site:AC102	Time: 2017/07/24 - 20:00
Limit: FCC_Part15.209_RE(3m)	Margin: 0
Probe: N/A	Polarity: Vertical
EUT:IP CAMERA	Power: AC 120V/60Hz
Note: Mode:Transmit 802.11g at 2462MHz	

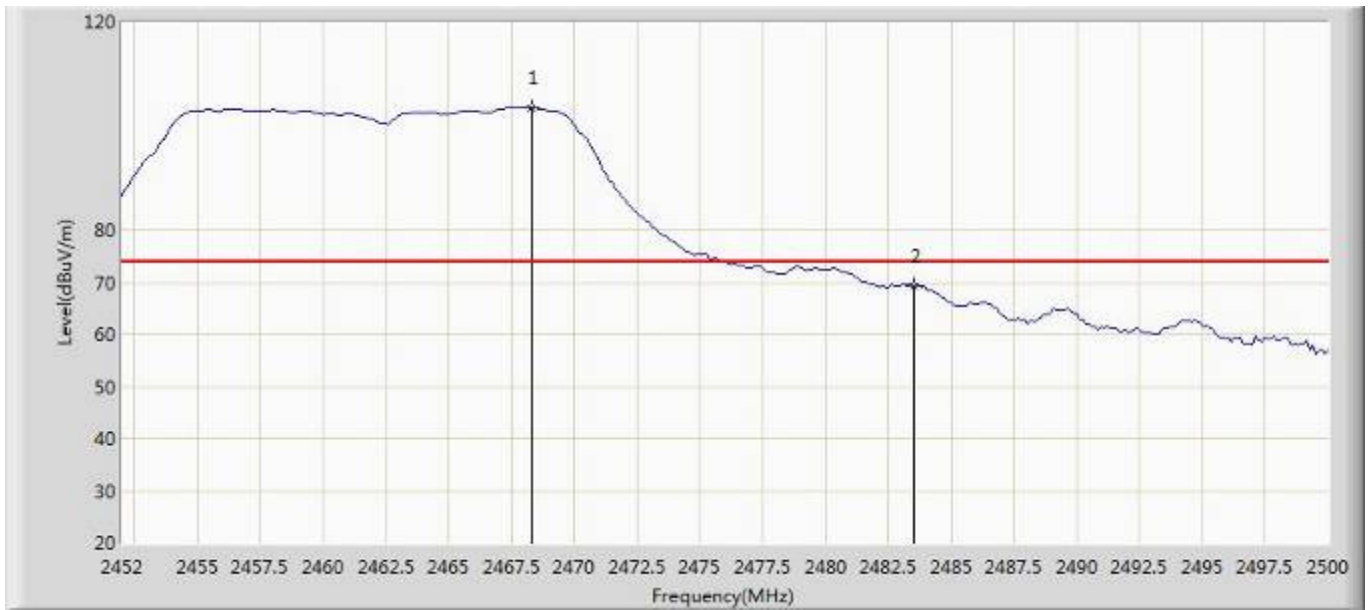

No	Mark	Frequency (MHz)	Measure Level (dBuV/m)	Reading Level (dBuV)	Over Limit (dB)	Limit (dBuV/m)	Factor (dB)	Type
1	*	2468.320	103.443	105.392	N/A	N/A	-1.949	PK
2		2483.500	69.371	71.263	-4.629	74.000	-1.892	PK



Site:AC102	Time: 2017/07/24 - 20:05
Limit: FCC_Part15.209_RE(3m)	Margin: 0
Probe: N/A	Polarity: Vertical
EUT:IP CAMERA	Power: AC 120V/60Hz
Note: Mode:Transmit 802.11g at 2462MHz	

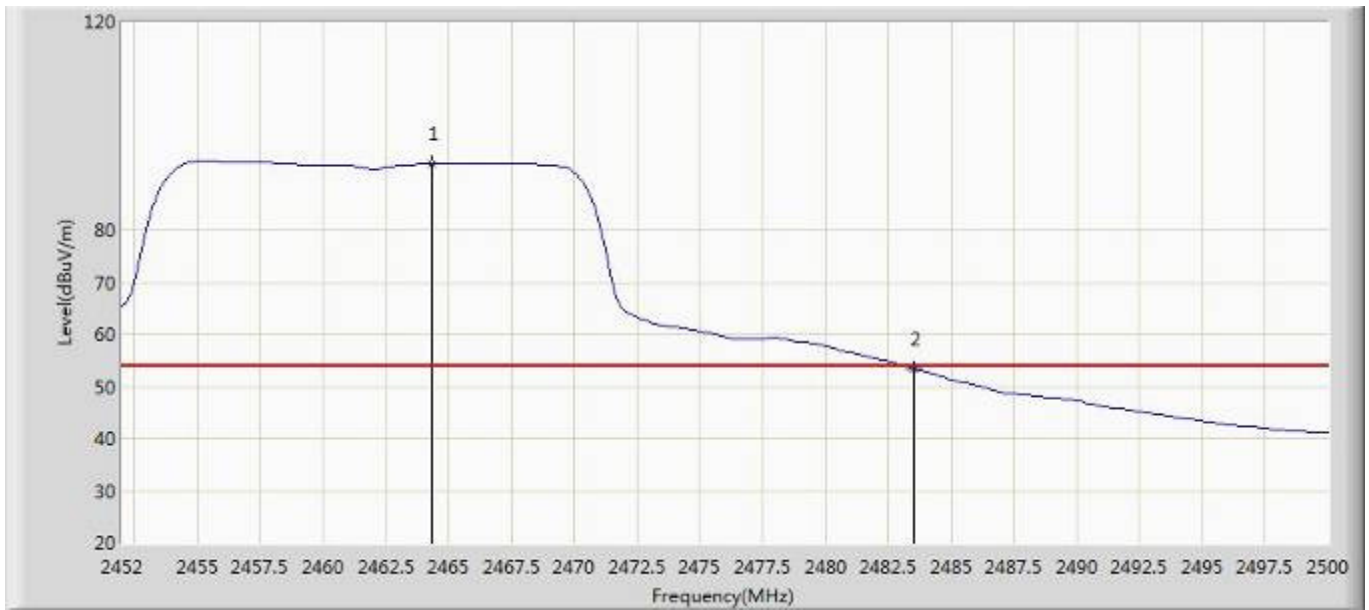

No	Mark	Frequency (MHz)	Measure Level (dBuV/m)	Reading Level (dBuV)	Over Limit (dB)	Limit (dBuV/m)	Factor (dB)	Type
1	*	2464.360	92.860	94.823	N/A	N/A	-1.963	AV
2		2483.500	53.446	55.338	-0.554	54.000	-1.892	AV



Site:AC102	Time: 2017/07/24 - 20:06
Limit: FCC_Part15.209_RE(3m)	Margin: 0
Probe: N/A	Polarity: Horizontal
EUT:IP CAMERA	Power: AC 120V/60Hz
Note: Mode:Transmit 802.11g at 2462MHz	

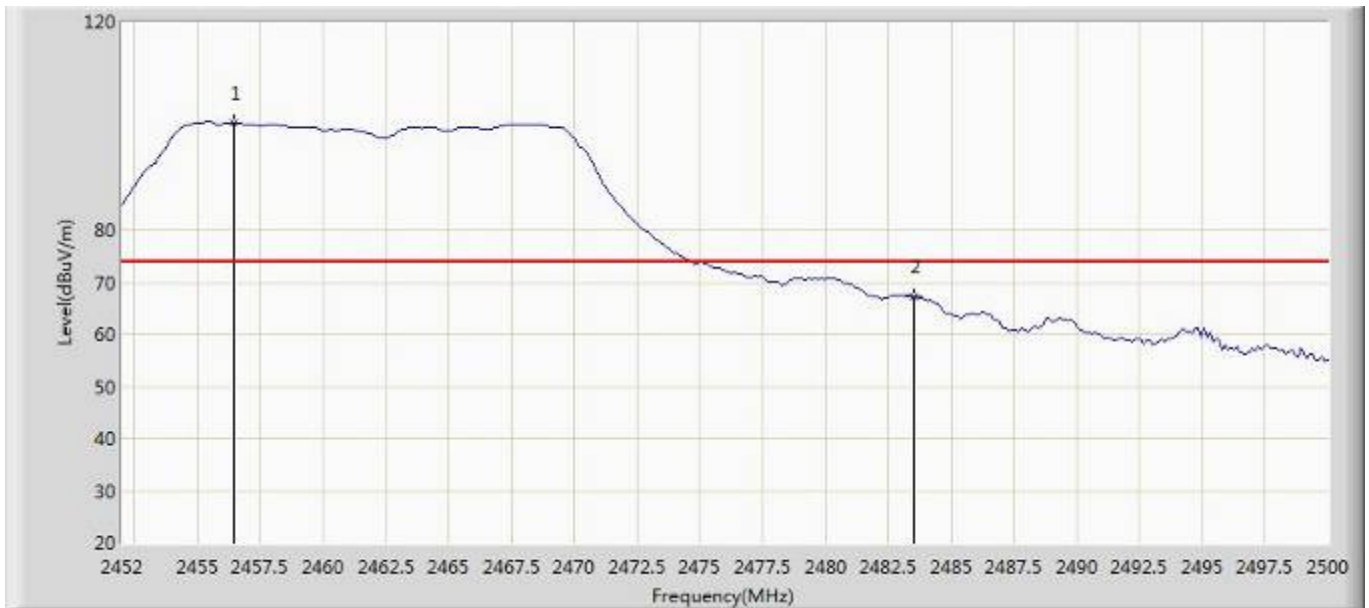

No	Mark	Frequency (MHz)	Measure Level (dBuV/m)	Reading Level (dBuV)	Over Limit (dB)	Limit (dBuV/m)	Factor (dB)	Type
1	*	2456.440	100.658	102.651	N/A	N/A	-1.993	PK
2		2483.500	67.281	69.173	-6.719	74.000	-1.892	PK



Site:AC102	Time: 2017/07/24 - 20:09
Limit: FCC_Part15.209_RE(3m)	Margin: 0
Probe: N/A	Polarity: Horizontal
EUT:IP CAMERA	Power: AC 120V/60Hz
Note: Mode:Transmit 802.11g at 2462MHz	



No	Mark	Frequency (MHz)	Measure Level (dBuV/m)	Reading Level (dBuV)	Over Limit (dB)	Limit (dBuV/m)	Factor (dB)	Type
1	*	2455.120	91.034	93.032	N/A	N/A	-1.998	AV
2		2483.500	51.717	53.609	-2.283	54.000	-1.892	AV



Site:AC102	Time: 2017/07/24 - 20:23
Limit: FCC_Part15.209_RE(3m)	Margin: 0
Probe: N/A	Polarity: Horizontal
EUT:IP CAMERA	Power: AC 120V/60Hz
Note: Mode:Transmit 802.11n20 at 2412MHz	

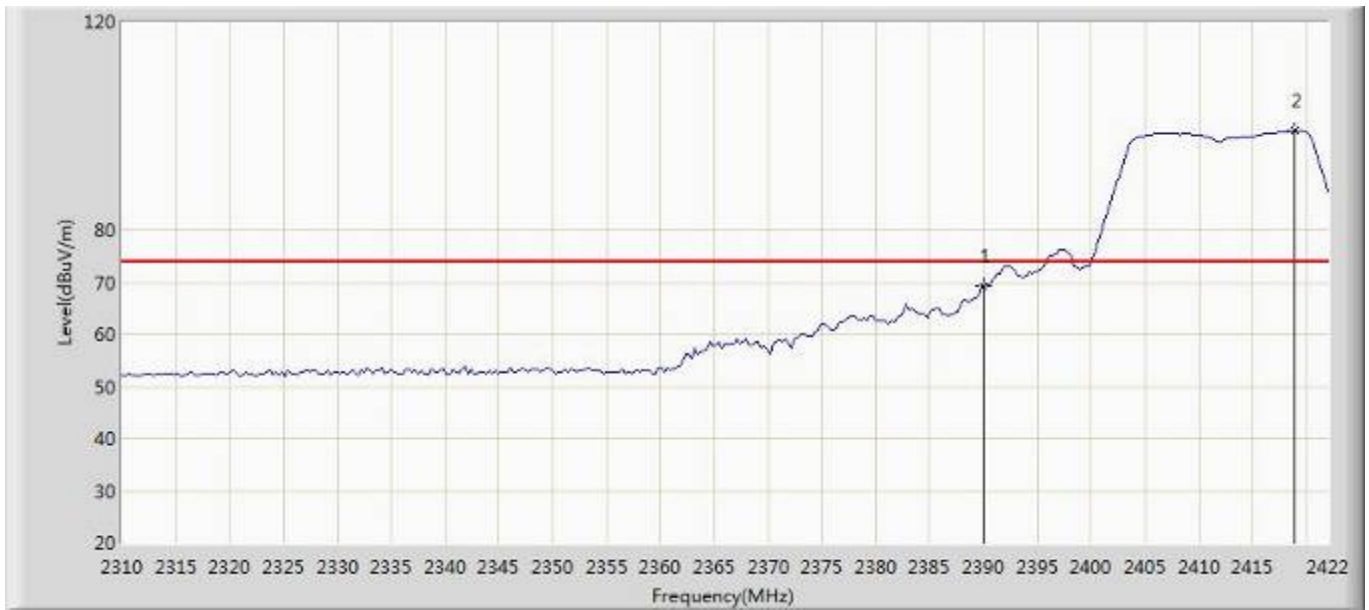

No	Mark	Frequency (MHz)	Measure Level (dBuV/m)	Reading Level (dBuV)	Over Limit (dB)	Limit (dBuV/m)	Factor (dB)	Type
1		2390.000	69.246	71.487	-4.754	74.000	-2.241	PK
2	*	2418.920	99.140	101.273	N/A	N/A	-2.133	PK



Site:AC102	Time: 2017/07/24 - 20:29
Limit: FCC_Part15.209_RE(3m)	Margin: 0
Probe: N/A	Polarity: Horizontal
EUT:IP CAMERA	Power: AC 120V/60Hz
Note: Mode:Transmit 802.11n20 at 2412MHz	

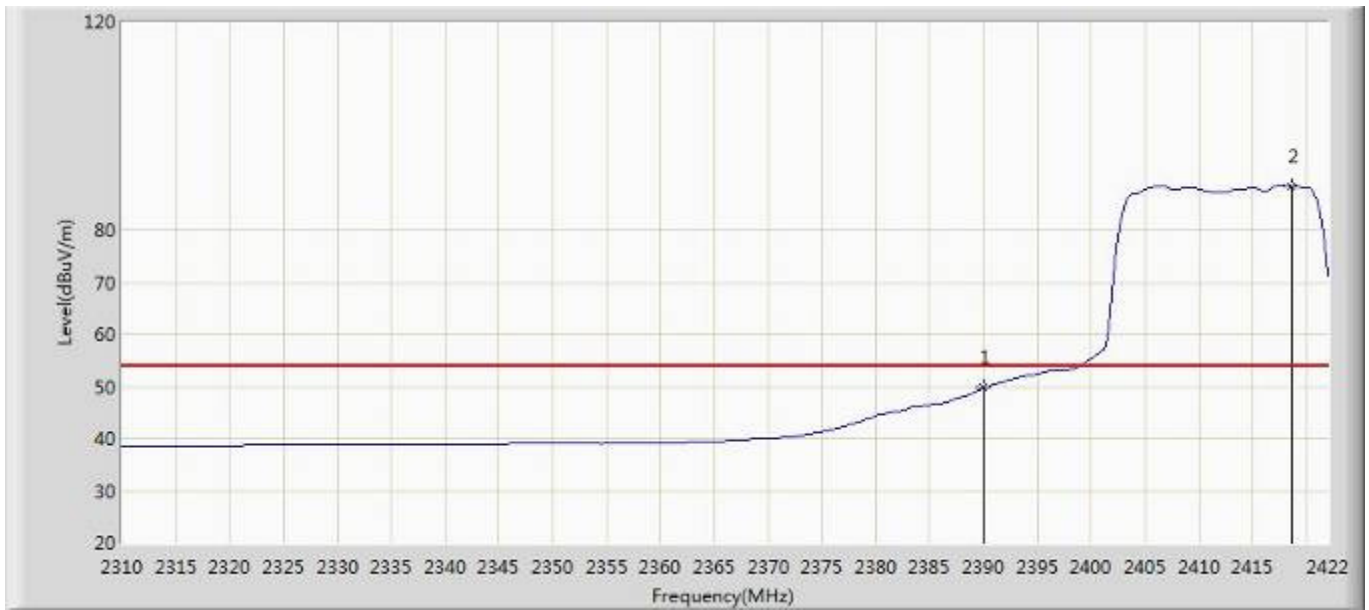

No	Mark	Frequency (MHz)	Measure Level (dBuV/m)	Reading Level (dBuV)	Over Limit (dB)	Limit (dBuV/m)	Factor (dB)	Type
1		2390.000	49.728	51.969	-4.272	54.000	-2.241	AV
2	*	2418.640	88.546	90.680	N/A	N/A	-2.134	AV



Site:AC102	Time: 2017/07/24 - 20:30
Limit: FCC_Part15.209_RE(3m)	Margin: 0
Probe: N/A	Polarity: Vertical
EUT:IP CAMERA	Power: AC 120V/60Hz
Note: Mode:Transmit 802.11n20 at 2412MHz	



No	Mark	Frequency (MHz)	Measure Level (dBuV/m)	Reading Level (dBuV)	Over Limit (dB)	Limit (dBuV/m)	Factor (dB)	Type
1		2390.000	71.526	73.767	-2.474	74.000	-2.241	PK
2	*	2418.920	100.903	103.036	N/A	N/A	-2.133	PK



Site:AC102	Time: 2017/07/24 - 20:34
Limit: FCC_Part15.209_RE(3m)	Margin: 0
Probe: N/A	Polarity: Vertical
EUT:IP CAMERA	Power: AC 120V/60Hz
Note: Mode:Transmit 802.11n20 at 2412MHz	

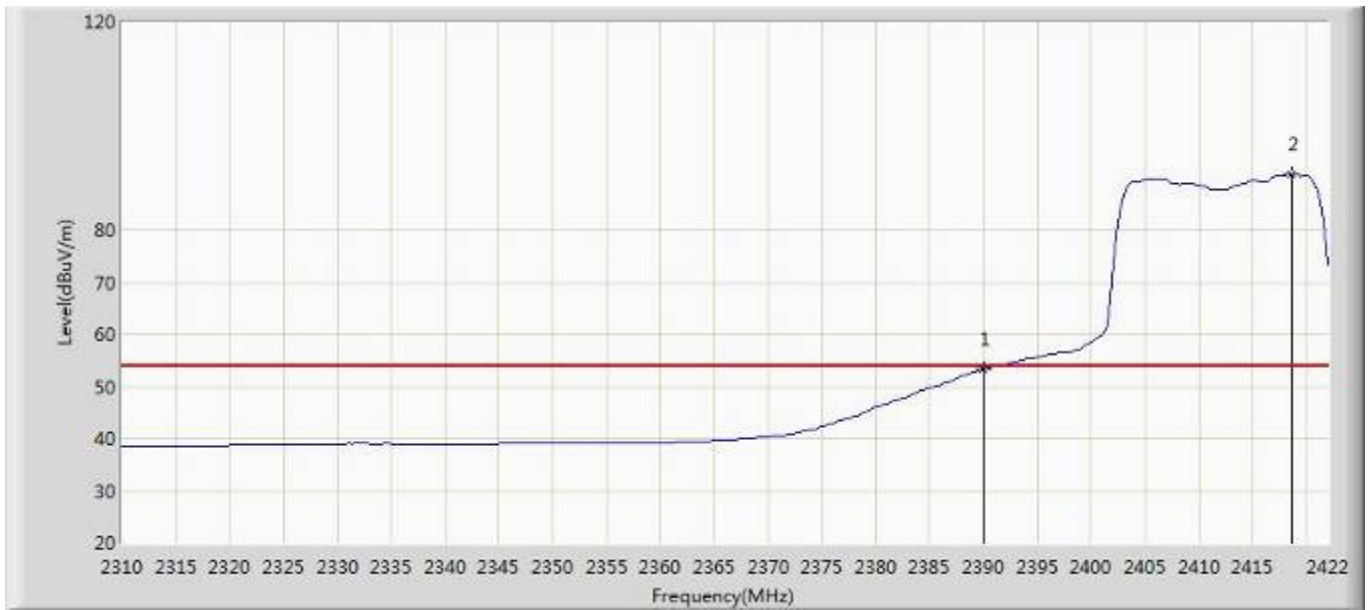

No	Mark	Frequency (MHz)	Measure Level (dBuV/m)	Reading Level (dBuV)	Over Limit (dB)	Limit (dBuV/m)	Factor (dB)	Type
1		2390.000	53.471	55.712	-0.529	54.000	-2.241	AV
2	*	2418.640	90.680	92.814	N/A	N/A	-2.134	AV



Site:AC102	Time: 2017/07/24 - 20:35
Limit: FCC_Part15.209_RE(3m)	Margin: 0
Probe: N/A	Polarity: Vertical
EUT:IP CAMERA	Power: AC 120V/60Hz
Note: Mode:Transmit 802.11n20 at 2462MHz	



No	Mark	Frequency (MHz)	Measure Level (dBuV/m)	Reading Level (dBuV)	Over Limit (dB)	Limit (dBuV/m)	Factor (dB)	Type
1	*	2456.680	101.361	103.353	N/A	N/A	-1.992	PK
2		2483.500	67.875	69.767	-6.125	74.000	-1.892	PK



Site:AC102	Time: 2017/07/24 - 20:39
Limit: FCC_Part15.209_RE(3m)	Margin: 0
Probe: N/A	Polarity: Vertical
EUT:IP CAMERA	Power: AC 120V/60Hz
Note: Mode:Transmit 802.11n20 at 2462MHz	

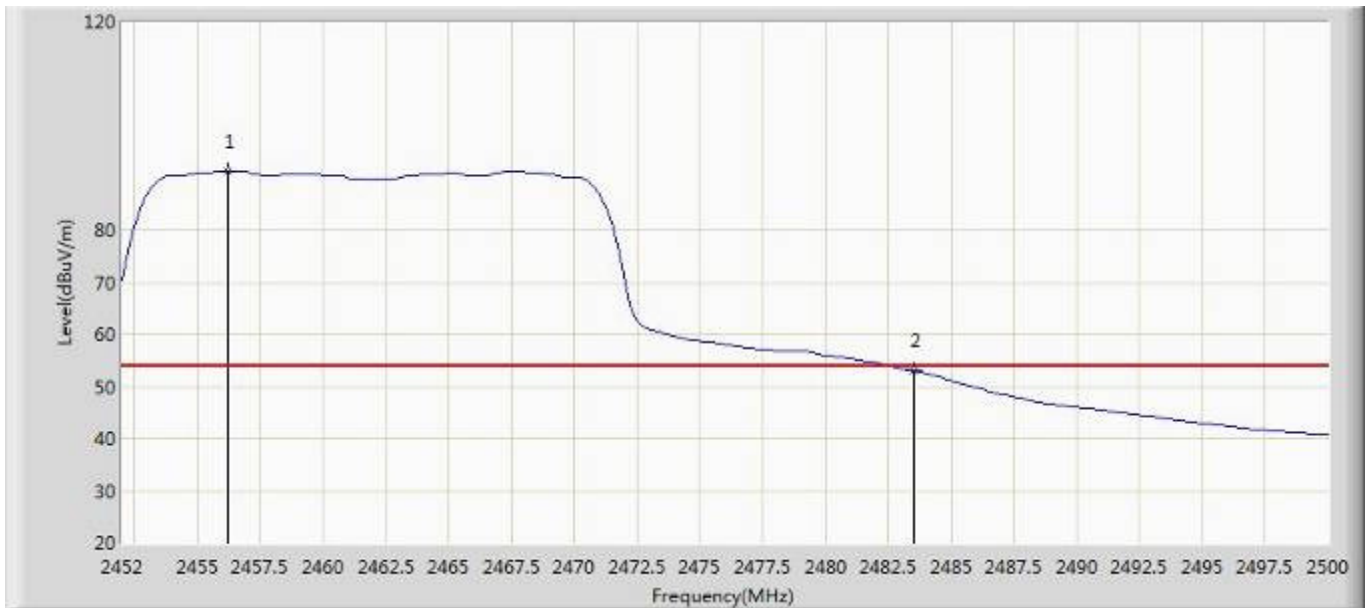

No	Mark	Frequency (MHz)	Measure Level (dBuV/m)	Reading Level (dBuV)	Over Limit (dB)	Limit (dBuV/m)	Factor (dB)	Type
1	*	2456.200	91.303	93.297	N/A	N/A	-1.994	AV
2		2483.500	52.955	54.847	-1.045	54.000	-1.892	AV



Site:AC102	Time: 2017/07/24 - 20:44
Limit: FCC_Part15.209_RE(3m)	Margin: 0
Probe: N/A	Polarity: Horizontal
EUT:IP CAMERA	Power: AC 120V/60Hz
Note: Mode:Transmit 802.11n20 at 2462MHz	



No	Mark	Frequency (MHz)	Measure Level (dBuV/m)	Reading Level (dBuV)	Over Limit (dB)	Limit (dBuV/m)	Factor (dB)	Type
1	*	2456.560	99.099	101.091	N/A	N/A	-1.992	PK
2		2483.500	66.949	68.841	-7.051	74.000	-1.892	PK



Site:AC102	Time: 2017/07/24 - 20:46
Limit: FCC_Part15.209_RE(3m)	Margin: 0
Probe: N/A	Polarity: Horizontal
EUT:IP CAMERA	Power: AC 120V/60Hz
Note: Mode:Transmit 802.11n20 at 2462MHz	

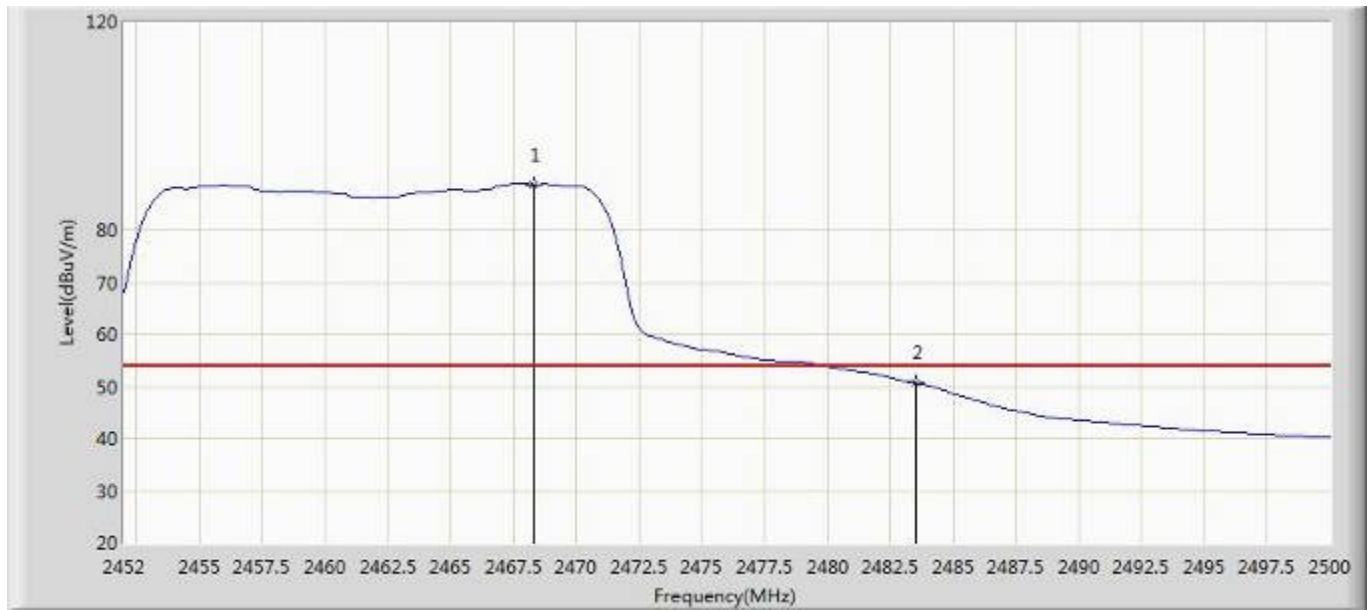

No	Mark	Frequency (MHz)	Measure Level (dBuV/m)	Reading Level (dBuV)	Over Limit (dB)	Limit (dBuV/m)	Factor (dB)	Type
1	*	2468.320	88.822	90.771	N/A	N/A	-1.949	AV
2		2483.500	50.584	52.476	-3.416	54.000	-1.892	AV



Site:AC102	Time: 2017/07/24 - 20:48
Limit: FCC_Part15.209_RE(3m)	Margin: 0
Probe: N/A	Polarity: Horizontal
EUT:IP CAMERA	Power: AC 120V/60Hz
Note: Mode:Transmit 802.11n40 at 2422MHz	

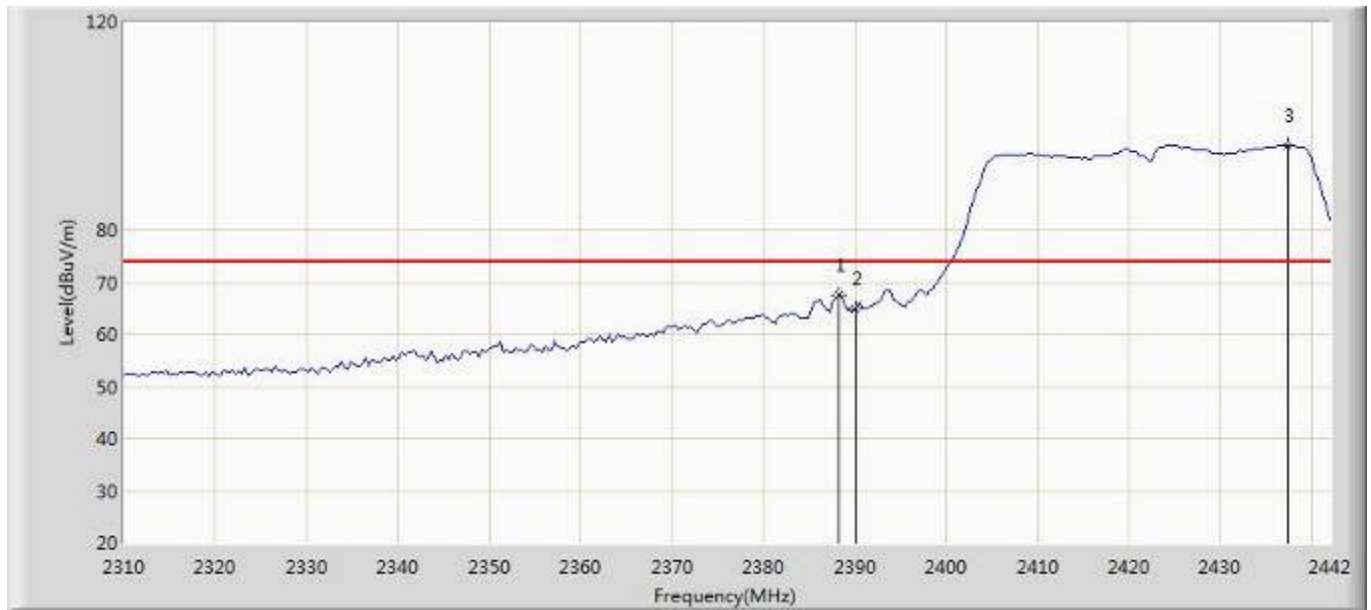

No	Mark	Frequency (MHz)	Measure Level (dBuV/m)	Reading Level (dBuV)	Over Limit (dB)	Limit (dBuV/m)	Factor (dB)	Type
1		2388.210	67.671	69.919	-6.329	74.000	-2.248	PK
2		2390.000	64.976	67.217	-9.024	74.000	-2.241	PK
3	*	2437.380	96.283	98.347	N/A	N/A	-2.064	PK



Site:AC102	Time: 2017/07/24 - 20:54
Limit: FCC_Part15.209_RE(3m)	Margin: 0
Probe: N/A	Polarity: Horizontal
EUT:IP CAMERA	Power: AC 120V/60Hz
Note: Mode:Transmit 802.11n40 at 2422MHz	

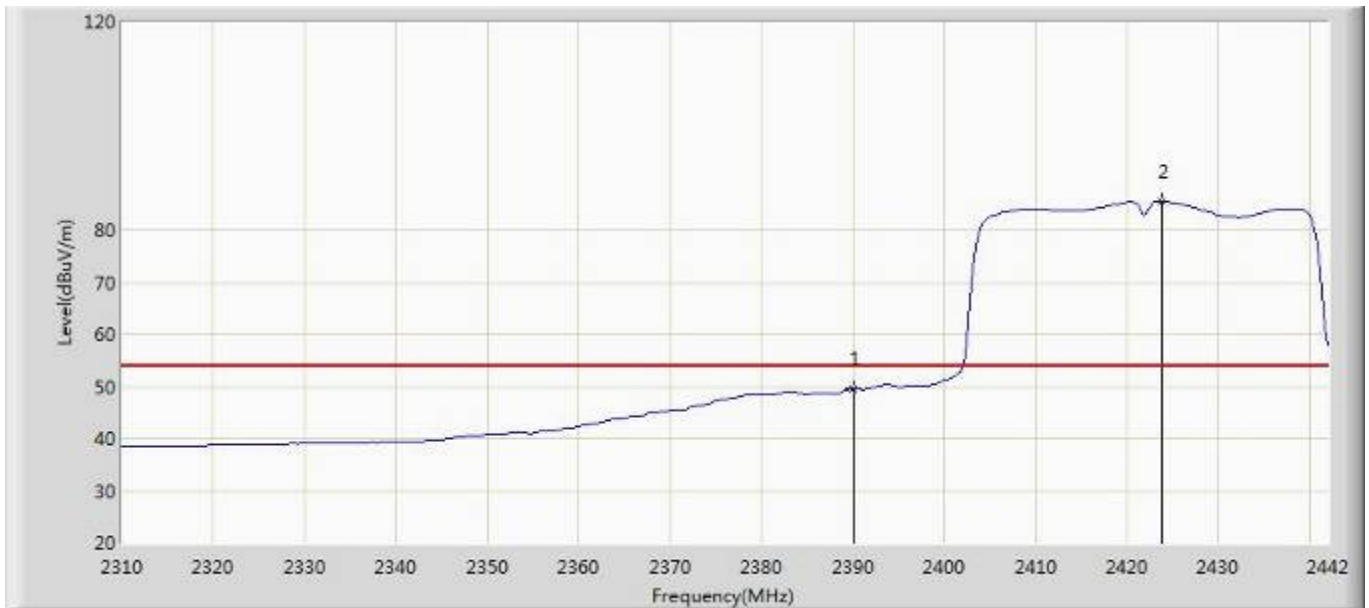

No	Mark	Frequency (MHz)	Measure Level (dBuV/m)	Reading Level (dBuV)	Over Limit (dB)	Limit (dBuV/m)	Factor (dB)	Type
1		2390.000	49.445	51.686	-4.555	54.000	-2.241	AV
2	*	2423.850	85.556	87.671	N/A	N/A	-2.115	AV



Site:AC102	Time: 2017/07/24 - 20:54
Limit: FCC_Part15.209_RE(3m)	Margin: 0
Probe: N/A	Polarity: Vertical
EUT:IP CAMERA	Power: AC 120V/60Hz
Note: Mode:Transmit 802.11n40 at 2422MHz	

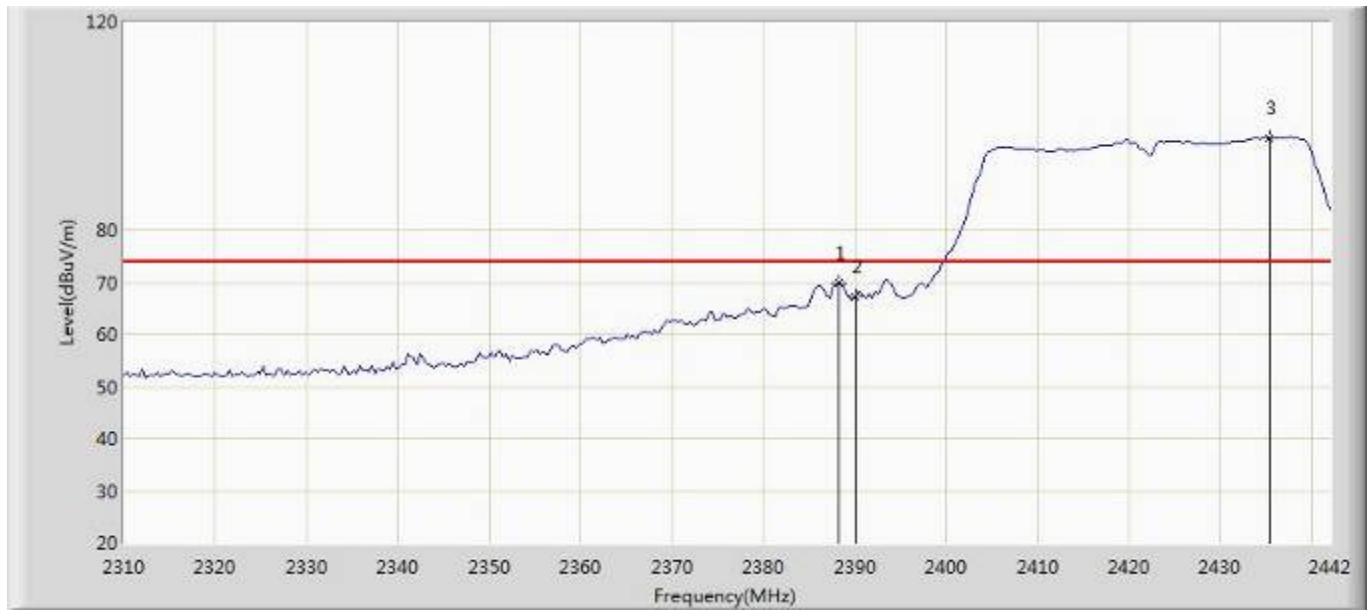

No	Mark	Frequency (MHz)	Measure Level (dBuV/m)	Reading Level (dBuV)	Over Limit (dB)	Limit (dBuV/m)	Factor (dB)	Type
1		2388.210	69.939	72.187	-4.061	74.000	-2.248	PK
2		2390.000	67.238	69.479	-6.762	74.000	-2.241	PK
3	*	2435.400	97.807	99.879	N/A	N/A	-2.072	PK



Site:AC102	Time: 2017/07/24 - 20:57
Limit: FCC_Part15.209_RE(3m)	Margin: 0
Probe: N/A	Polarity: Vertical
EUT:IP CAMERA	Power: AC 120V/60Hz
Note: Mode:Transmit 802.11n40 at 2422MHz	

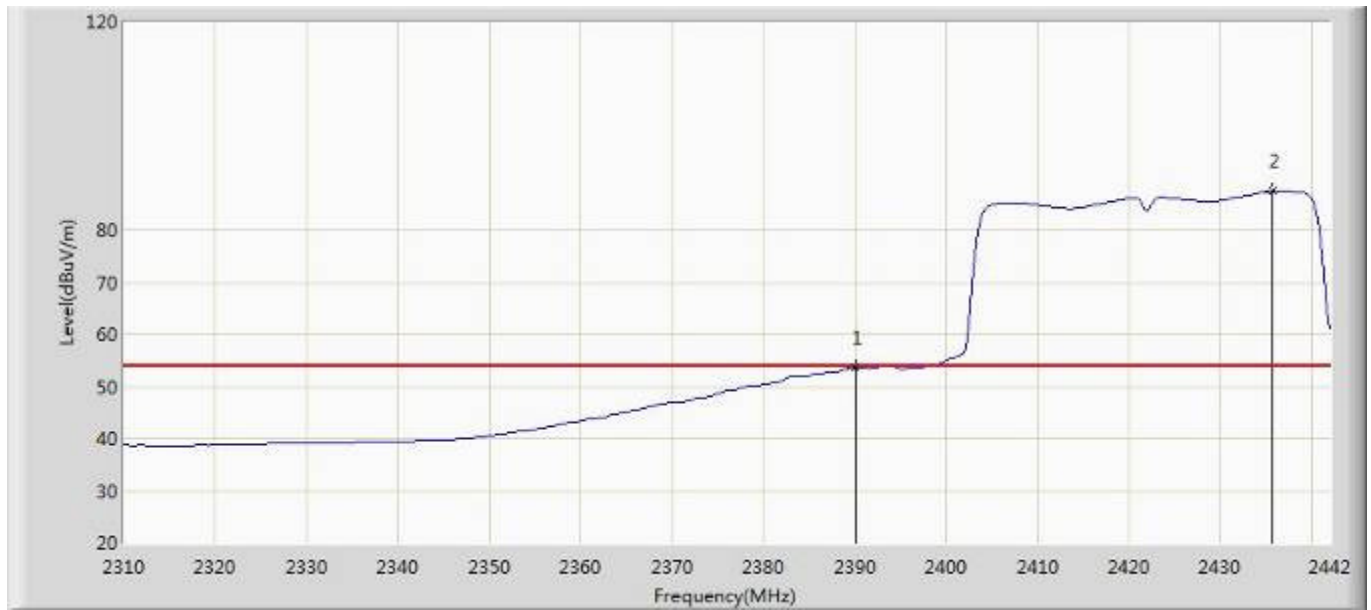

No	Mark	Frequency (MHz)	Measure Level (dBuV/m)	Reading Level (dBuV)	Over Limit (dB)	Limit (dBuV/m)	Factor (dB)	Type
1		2390.000	53.726	55.967	-0.274	54.000	-2.241	AV
2	*	2435.730	87.404	89.474	N/A	N/A	-2.070	AV



Site:AC102	Time: 2017/07/24 - 20:59
Limit: FCC_Part15.209_RE(3m)	Margin: 0
Probe: N/A	Polarity: Vertical
EUT:IP CAMERA	Power: AC 120V/60Hz
Note: Mode:Transmit 802.11n40 at 2452MHz	



No	Mark	Frequency (MHz)	Measure Level (dBuV/m)	Reading Level (dBuV)	Over Limit (dB)	Limit (dBuV/m)	Factor (dB)	Type
1	*	2438.630	96.558	98.618	N/A	N/A	-2.060	PK
2		2483.500	66.446	68.338	-7.554	74.000	-1.892	PK
3		2488.100	67.436	69.311	-6.564	74.000	-1.875	PK



Site:AC102	Time: 2017/07/24 - 21:03
Limit: FCC_Part15.209_RE(3m)	Margin: 0
Probe: N/A	Polarity: Vertical
EUT:IP CAMERA	Power: AC 120V/60Hz
Note: Mode:Transmit 802.11n40 at 2452MHz	

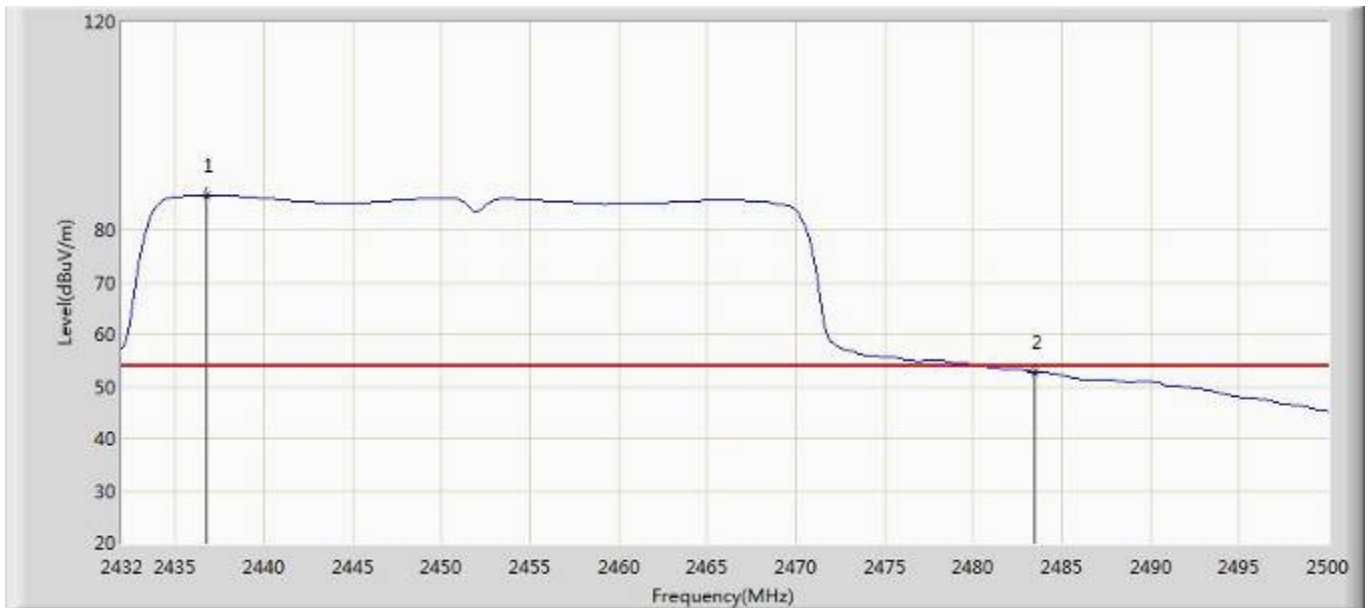

No	Mark	Frequency (MHz)	Measure Level (dBuV/m)	Reading Level (dBuV)	Over Limit (dB)	Limit (dBuV/m)	Factor (dB)	Type
1	*	2436.760	86.651	88.718	N/A	N/A	-2.067	AV
2		2483.500	52.803	54.695	-1.197	54.000	-1.892	AV



Site:AC102	Time: 2017/07/24 - 21:05
Limit: FCC_Part15.209_RE(3m)	Margin: 0
Probe: N/A	Polarity: Horizontal
EUT:IP CAMERA	Power: AC 120V/60Hz
Note: Mode:Transmit 802.11n40 at 2452MHz	

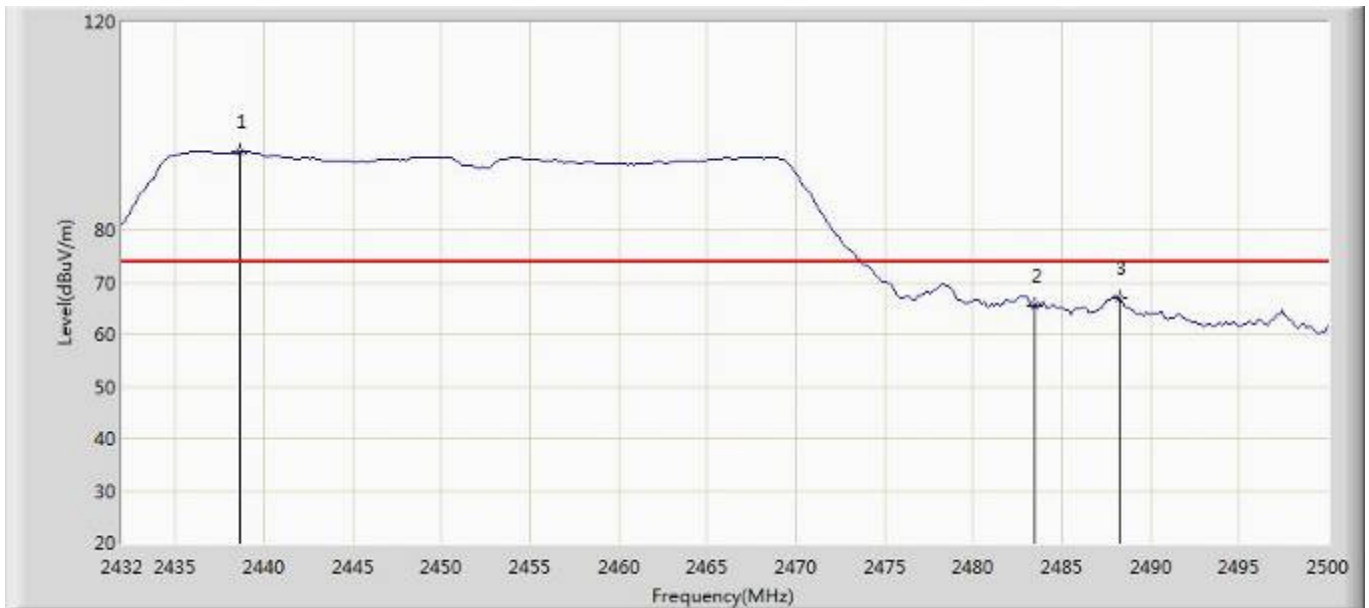

No	Mark	Frequency (MHz)	Measure Level (dBuV/m)	Reading Level (dBuV)	Over Limit (dB)	Limit (dBuV/m)	Factor (dB)	Type
1	*	2438.630	94.957	97.017	N/A	N/A	-2.060	PK
2		2483.500	65.645	67.537	-8.355	74.000	-1.892	PK
3		2488.270	67.100	68.974	-6.900	74.000	-1.874	PK



Site:AC102	Time: 2017/07/24 - 21:08
Limit: FCC_Part15.209_RE(3m)	Margin: 0
Probe: N/A	Polarity: Horizontal
EUT:IP CAMERA	Power: AC 120V/60Hz
Note: Mode:Transmit 802.11n40 at 2452MHz	

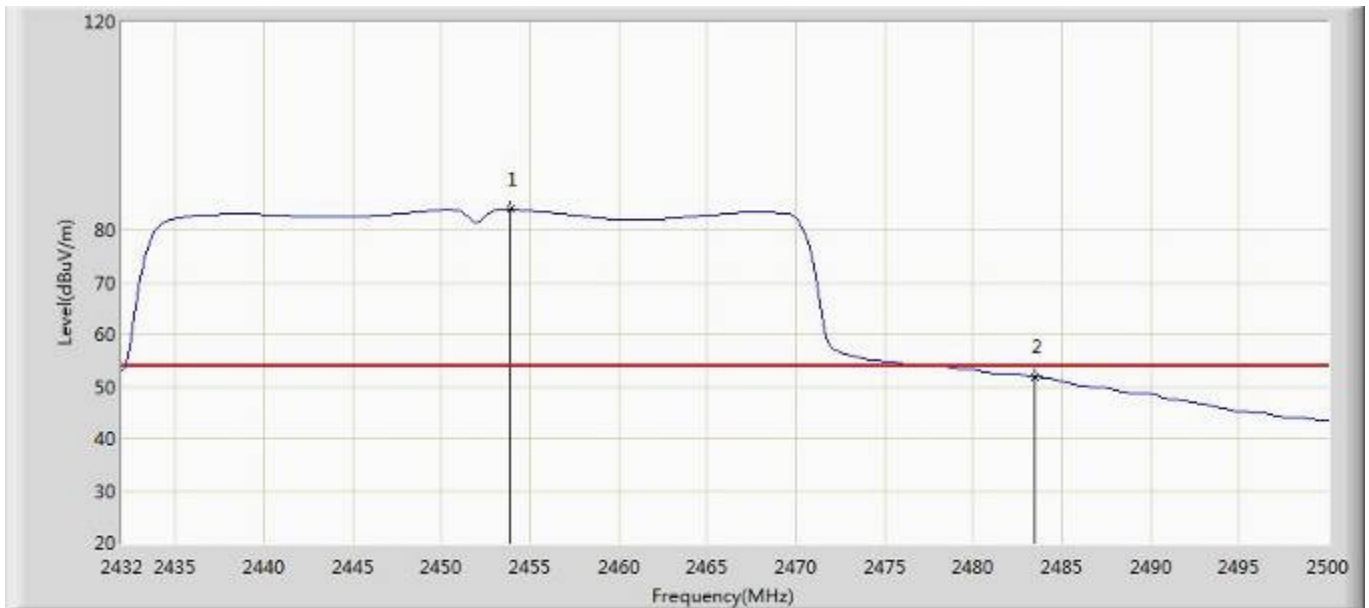

No	Mark	Frequency (MHz)	Measure Level (dBuV/m)	Reading Level (dBuV)	Over Limit (dB)	Limit (dBuV/m)	Factor (dB)	Type
1	*	2453.930	84.021	86.023	N/A	N/A	-2.002	AV
2		2483.500	51.802	53.694	-2.198	54.000	-1.892	AV

The End