



FCC TEST REPORT

Applicant : Amcrest Technologies LLC

Address : 16727 Park Row Dr.Houston, TX 77084

Manufacturer : Zhejiang Dahua Vision Technology Co., Ltd.

Address : No.1199, Bin'an Road, Binjiang District, Hangzhou, P.R. China

Equipment : 1080P Pan/Tilt Wireless IP Camera;720P Pan/Tilt Wireless IP Camera

IP2M-841B;IP2M-841W;IP2M-841S;IP2M-841B-UK;IP2M-841W-UK;IP2M-841S-UK;IP2M-841B-EU; IP2M-841W-EU;

IP2M-841S-EU; IPM-721B; IPM-721W; IPM-721S; IPM-721B-UK; IPM-721W-UK; IPM-721S-UK;

IPM-721B-EU;IPM-721W-EU;IPM-721S-EU;

Model No. :

IP2M-841B-*****;IP2M-841W-*****;IP2M-841S-*****;IPM-721B-*****;IPM-721W-*****;IPM-721S-***** (***** can be

“A-Z” ’or“_” or blank) IP2M-841-Y7;IPM-741-Y7; IP2M-841B-Y7;IPM-721B-Y7; IP2M-841W-Y7;IPM-721W-Y7;

IP2M-841S-Y7;IPM-721S-Y7

Brand Name : AMCREST

FCC ID : ZZ2AMC000AMC001

- The test result refers exclusively to the test presented test model / sample.
- Without written approval of **CerpPASS Technology Corp.** the test report shall not be reproduced except in full.

I HEREBY CERTIFY THAT :

The measurements shown in this test report were made in accordance with the procedures given in **ANSI C63.10 – 2013** and the energy emitted by this equipment was **passed**.

FCC Part 15 in both radiated and conducted emission class B limits. Testing was carried out on Jul 08,2016~Aug 08, 2016 at **CerpPASS Technology Corp.**

Prepared By:

Kerry Zhou

Approved by:

Miro Chueh (EMC/RF Manager)

Laboratory Accreditation:

CerpPASS Technology Corporation Test Laboratory



NVLAP LAB Code:	200954-0
TAF LAB Code:	1439

CerpPASS Technology (SuZhou) Co., Ltd.



NVLAP LAB Code:	200814-0
CNAS LAB Code:	L5515



Release History

Attachment No.	Version	Date	Description
SEF11606292	Rev 01	2016-08-12	Initial release



Table of Contents

1. Report of Measurements and Examinations	5
1.1 List of Measurements and Examinations	5
2. Test Configuration of Equipment under Test	6
2.1 Feature of Equipment under Test	6
2.2 Carrier Frequency of Channels	7
2.3 Power Setting Levels	7
2.4 Duty cycle	8
2.5 Test Manner	9
2.6 Description of Test System	10
2.7 Configuration of Tested System	11
2.8 General Information of Test	12
2.9 Measurement Uncertainty	12
3. Antenna Requirements	13
3.1 Standard Applicable	13
3.2 Antenna Construction and Directional Gain	13
4. Test of Conducted Emission	14
4.1 Test Limit	14
4.2 Test Procedures.....	14
4.3 Typical Test Setup	15
4.4 Measurement Equipment	15
4.5 Test Result and Data	16
5. Test of Radiated Emission	18
5.1 Test Limit	18
5.2 Test Procedures.....	18
5.3 Test Setting	19
5.4 Typical Test Setup	20
5.5 Measurement Equipment	22
5.6 Test Result and Data	23
6. Maximum Output Power	49
6.1 Test Limit	49
6.2 Test Procedure	49
6.3 Test Setup Layout.....	49
6.4 Measurement Equipment	49
6.5 Test Result and Data	50
7. Occupied Bandwidth	53
7.1 Test Limit	53
7.2 Test Procedures.....	53
7.3 Test Setup Layout.....	53
7.4 Measurement Equipment	53
7.5 Test Result and Data	54
8. Power Spectral Density	58
8.1 Test Limit	58



8.2	Test Procedure	58
8.3	Test Setup Layout.....	58
8.4	Measurement Equipment	58
8.5	Test Result and Data	59
9.	Band Edges Measurement.....	63
9.1	Test Limit	63
9.2	Test Procedure	64
9.3	Test Setting	64
9.4	Test Setup Layout.....	65
9.5	Measurement Equipment	66
9.6	Test Result and Data	67
10.	Restricted Bands of Operation.....	107
10.1	Labeling Requirement	107



1. Report of Measurements and Examinations

1.1 List of Measurements and Examinations

Performed Test Item	Normative References	Test Performed	Deviation	Result
Conducted Emission	FCC CFR Title 47 Part 15 Subpart C: 2014 Section 15.207	Yes	N/A	Pass
Radiated Emission	FCC CFR Title 47 Part 15 Subpart C: 2014 Section 15.209 RSS-Gen Issue 4 November 2014 Section 6.13	Yes	No	Pass
RF Antenna Conducted Spurious	FCC CFR Title 47 Part 15 Subpart C: 2014 Section 15.247(d) RSS-247 Issue 1 May 2015 Section 5.5	Yes	No	Pass
Radiated Emission Band Edge	FCC CFR Title 47 Part 15 Subpart C: 2014 15.247(d) RSS-247 Issue 1 May 2015 Section 5.5	Yes	No	Pass
Operation Frequency Range of 20dB Bandwidth	FCC CFR Title 47 Part 15 Subpart C: 2014 15.215(c)	Yes	No	Pass
Occupied Bandwidth	FCC CFR Title 47 Part 15 Subpart C: 2014 Section 15.247(a)(2) RSS-247 Issue 1 May 2015 Section 5.2(1)	Yes	No	Pass
Output Power	FCC CFR Title 47 Part 15 Subpart C: 2014 Section 15.247(b)(3) RSS-247 Issue 1 May 2015 Section 5.4(4)	Yes	No	Pass
Power Spectral Density	FCC CFR Title 47 Part 15 Subpart C: 2014 Section 15.247(e) RSS-247 Issue 1 May 2015 Section 5.2(2)	Yes	No	Pass



2. Test Configuration of Equipment under Test

2.1 Feature of Equipment under Test

WIFI Module	RTL8188ETV
Spreading	802.11b: CCK, DQPSK, DBPSK 802.11g: 64 QAM, 16 QAM, QPSK, BPSK 802.11n: BPSK, QPSK, 16-QAM, 64-QAM
Frequency Range	802.11b/g/n(20MHz): 2412-2462MHz 802.11n(40MHz): 2422-2452MHz
Number of Channels	802.11b/g/n (20MHz):11 802.11n (40MHz): 7
Data Rate	802.11b: 11, 5.5, 2, 1 Mbps 802.11g: 54, 48, 36, 24, 18, 12, 9, 6 Mbps 802.11n: up to 300Mbps
Antenna Type	See antenna requirement

Power supply	Model No:	HKC0115020-2B
	Input:	100~240V~50-60Hz Max0.5A
	Output:	5V \pm 2.0A



2.2 Carrier Frequency of Channels

For 2.4G 802.11b, 802.11g, 802.11n (20MHz)

Channel	Frequency(MHz)	Channel	Frequency(MHz)
01	2412	07	2442
02	2417	08	2447
03	2422	09	2452
04	2427	10	2457
05	2432	11	2462
06	2437	---	---

For 2.4G 802.11n (40MHz)

Channel	Frequency(MHz)	Channel	Frequency(MHz)
01	---	08	2447
02	---	09	2452
03	2422	---	---
04	2427	---	---
05	2432	---	---
06	2437	---	---
07	2442	---	---

2.3 Power Setting Levels

Mode	Frequency (MHz)	Power Setting
802.11b	2412	61
	2437	63
	2462	60
802.11g	2412	63
	2437	63
	2462	58
802.11n20	2412	58
	2437	63
	2462	55
802.11n40	2422	58
	2437	63
	2452	53

Note: Telnet software is used for power transmission control offered by the manufactory.



2.4 Duty cycle

Test Item	Duty cycle
-----------	------------

Mode	Frequency (MHz)	Measurement (%)
802.11b	2412	100%
802.11g	2412	100%
802.11n(20MHz)	2412	100%
802.11n(40MHz)	2422	100%



2.5 Test Manner

Test Manner	
1	During testing, the interface cables and equipment positions were varied according to C63.10.
2	Adjust the EUT at the test mode and the test channel. Then test.
Test mode	
1	Transmit by 802.11b
2	Transmit by 802.11g
3	Transmit by 802.11n (20MHz)
4	Transmit by 802.11n (40MHz)



2.6 Description of Test System

No	Device	Manufacturer	Model No.	Description
1	Notebook PC	SONY	PCG-71811P	Non-Shielded,1.5m (R33021)



2.7 Configuration of Tested System

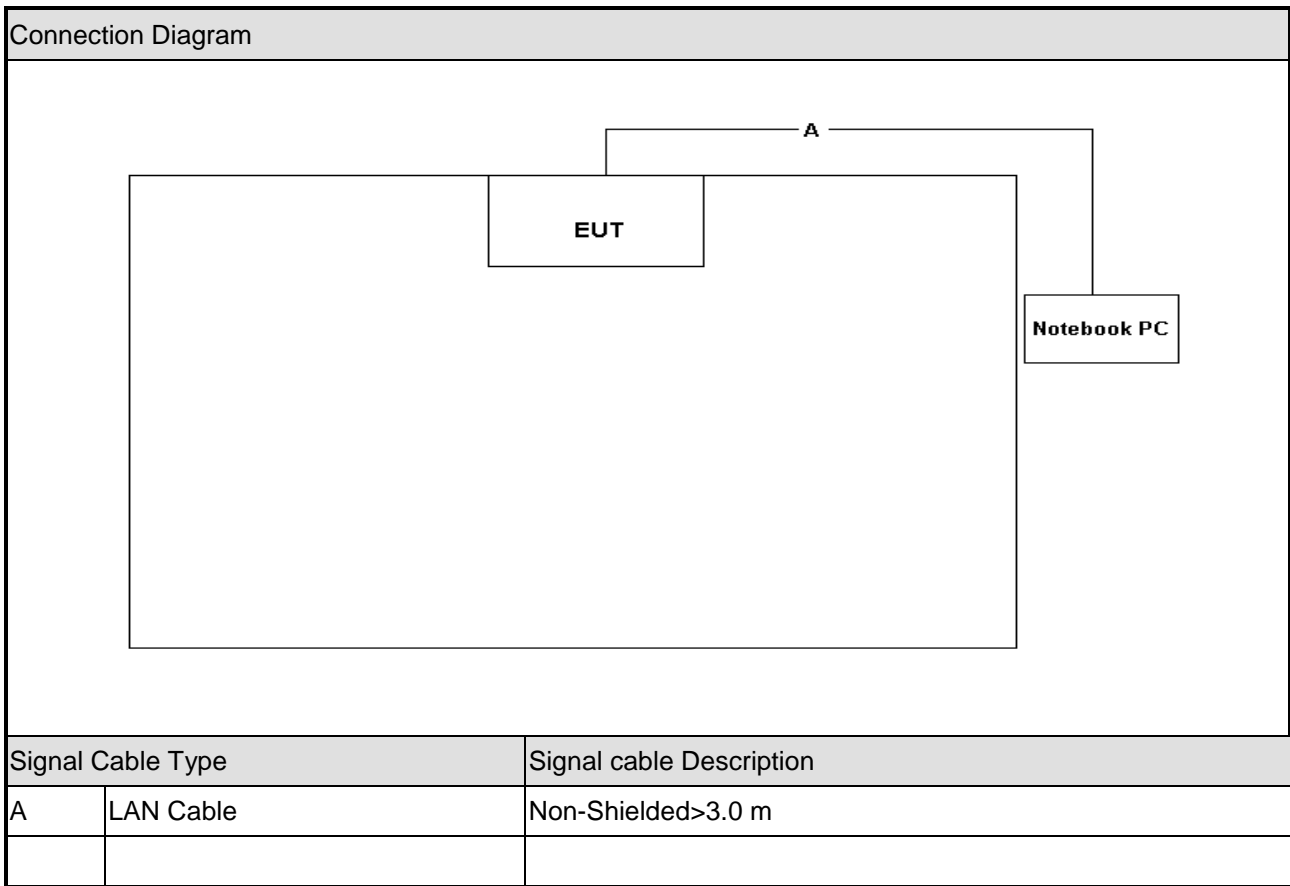



2.8 General Information of Test

Test Site:	CerpPASS Technology (SuZhou) Co., LTD
Performand Location :	No.66,Tangzhuang Road, Suzhou Industrial Park, Jiangsu 215006, China
NVLAP LAB Code :	200814-0
FCC Registration Number :	916572, 331395
IC Registration Number :	7290A-1, 7290A-2

2.9 Measurement Uncertainty

Measurement Item	Measurement Frequency	Polarization	Uncertainty
Conducted Emission	9 kHz ~ 30 MHz	LINE/NEUTRAL	±2.71 dB
Radiated Emission	9 kHz ~ 30 MHz	Vertical	±1.60 dB
		Horizontal	±1.60 dB
	30 MHz ~ 25GHz	Vertical	±4.11 dB
		Horizontal	±4.10 dB
Occupied Bandwidth	---	---	±7500 Hz
Maximum Peak Output Power	---	---	±1.4 dB
Power Spectral Density	---	---	±2.2 dB



3. Antenna Requirements

3.1 Standard Applicable

For intentional device, according to FCC 47 CFR Section 15.203, an intentional radiator shall be designed to ensure that no antenna other than that furnished by the responsible party shall be used with the device.

And according to FCC 47 CFR Section 15.247 (b), if transmitting antennas of directional gain greater than 6dBi are used, the power shall be reduced by the amount in dB that the directional gain of the antenna exceeds 6dBi.

3.2 Antenna Construction and Directional Gain

Antenna	Manufacturer	Model No.	Peak Gain
Airgain Embedded Antenna	Airgain, Inc.	N2430GNSM	2.3dBi for 2400~2500MHz band



4. Test of Conducted Emission

4.1 Test Limit

Conducted Emissions were measured from 150 kHz to 30 MHz with a bandwidth of 9 KHz on the 120 VAC power and return leads of the EUT according to the methods defined in ANSI C63.10-2013. The EUT was placed on a nonmetallic stand in a shielded room 0.8 meters above the ground plane as shown in section 6.2.2. The interface cables and equipment positioning were varied within limits of reasonable applications to determine the position produced maximum conducted emissions.

Frequency (MHz)	Quasi Peak (dB μ V)	AVG (dB μ V)
0.15 – 0.5	66-56*	56-46*
0.5 – 5.0	56	46
5.0 – 30.0	60	50

*Decreases with the logarithm of the frequency.

4.2 Test Procedures

The EUT was setup according to ANSI C63.10, 2013. The EUT was placed on a platform of nominal size, 1 m by 1.5 m, raised 80 cm above the conducting ground plane. The vertical conducting plane was located 40 cm to the rear of the EUT. All other surfaces of EUT were at least 80 cm from any other grounded conducting surface. The EUT and simulators are connected to the main power through a line impedance stabilization network (LISN). The LISN provides a 50 ohm /50uH coupling impedance for the measuring equipment. The peripheral devices are also connected to the main power through a LISN. (Please refer to the block diagram of the test setup and photographs) Each current-carrying conductor of the EUT power cord, except the ground (safety) conductor, was individually connected through a LISN to the input power source. The excess length of the power cord between the EUT and the LISN receptacle were folded back and forth at the center of the lead to form a bundle not exceeding 40 cm in length. Conducted emissions were investigated over the frequency range from 0.15MHz to 30MHz using a receiver bandwidth of 9kHz.



4.3 Typical Test Setup

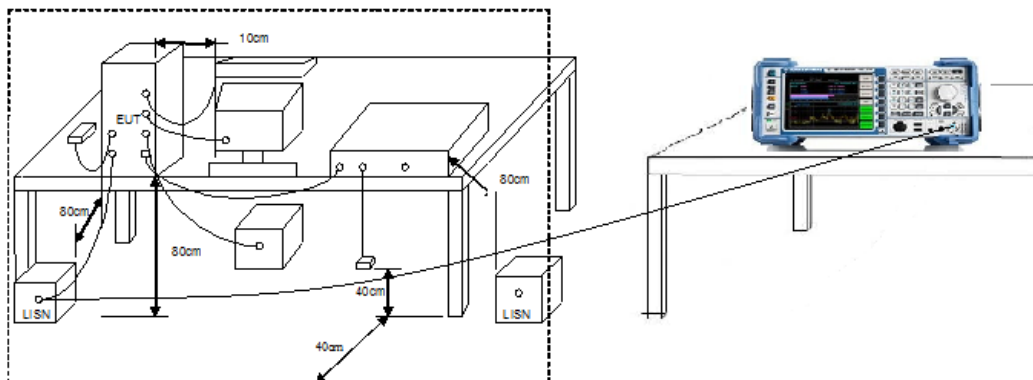

4.4 Measurement Equipment

Instrument	Manufacturer	Model No.	Serial No.	Calibration Date	Valid Date.
Test Receiver	R&S	ESCI	100565	2016.03.24	2017.03.23
AMN	R&S	ESH2-Z5	100182	2015.09.04	2016.09.03
Two-Line V-Network	R&S	ENV216	100325	2015.12.04	2016.12.03
ISN	FCC	FCC-TLISN-T2 -02	20379	2016.03.24	2017.03.23
ISN	FCC	FCC-TLISN-T4 -02	20380	2016.03.24	2017.03.23
ISN	FCC	FCC-TLISN-T8 -02	20381	2016.03.24	2017.03.23
ISN	TESEQ	ISN ST08	30175	2016.03.24	2017.03.23
Current Probe	R&S	EZ-17	100303	2016.04.04	2017.04.03
Passive Voltage Probe	R&S	ESH2-Z3	100026	2016.03.29	2017.03.28
Pulse Limiter	R&S	ESH3-Z2	100529	2016.03.29	2017.03.28
Temperature/ Humidity Meter	Zhicheng	ZC1-11	CEP-TH-004	2016.03.31	2017.03.30



4.5 Test Result and Data

Test Mode :	Mode 1: Normal Operation with wifi on		
AC Power :	AC 120V/60Hz	Phase :	LINE
Temperature :	22°C	Humidity :	50%
Pressure(mbar) :	1002	Date:	2016/08/06

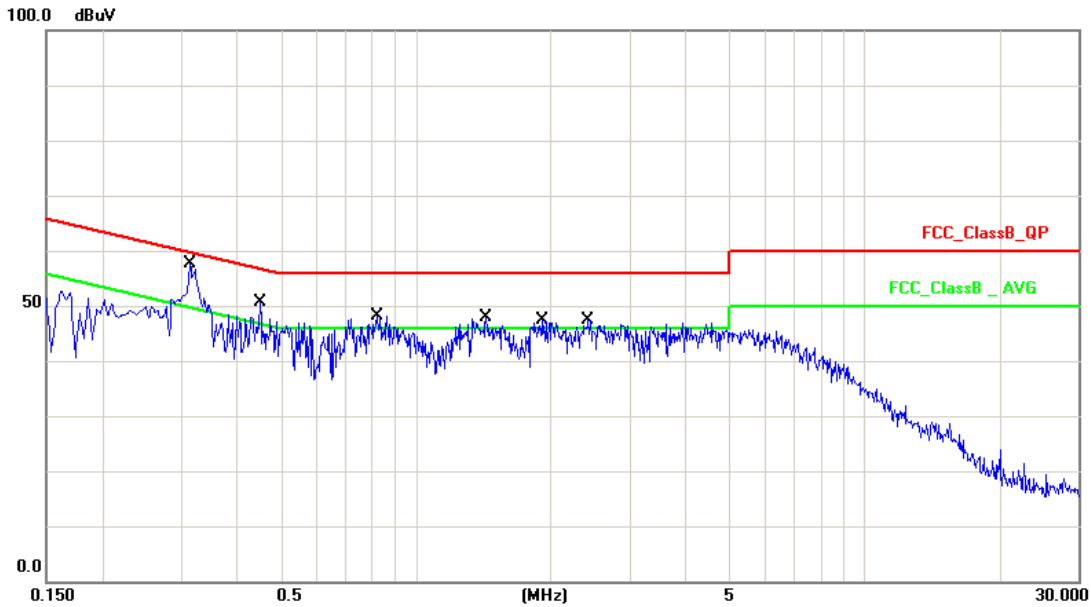

No.	Frequency (MHz)	Factor (dB)	Reading (dBuV)	Level (dBuV)	Limit (dBuV)	Margin (dB)	Detector
1	0.3140	10.14	39.84	49.98	59.86	-9.88	QP
2	0.3140	10.14	16.82	26.96	49.86	-22.90	AVG
3	0.4500	10.16	31.11	41.27	56.87	-15.60	QP
4	0.4500	10.16	7.65	17.81	46.87	-29.06	AVG
5	0.8260	10.15	30.76	40.91	56.00	-15.09	QP
6	0.8260	10.15	8.81	18.96	46.00	-27.04	AVG
7	1.4380	10.16	29.05	39.21	56.00	-16.79	QP
8	1.4380	10.16	6.80	16.96	46.00	-29.04	AVG
9	1.9100	10.17	29.03	39.20	56.00	-16.80	QP
10	1.9100	10.17	6.53	16.70	46.00	-29.30	AVG
11	2.4340	10.18	28.28	38.46	56.00	-17.54	QP
12	2.4340	10.18	5.43	15.61	46.00	-30.39	AVG

Note: Measurement Level = Reading Level + Correct Factor



Test Mode :	Mode 1: Normal Operation with wifi on		
AC Power :	AC 120V/60Hz	Phase :	NEUTRAL
Temperature :	22°C	Humidity :	50%
Pressure(mbar) :	1002	Date:	2016/08/06

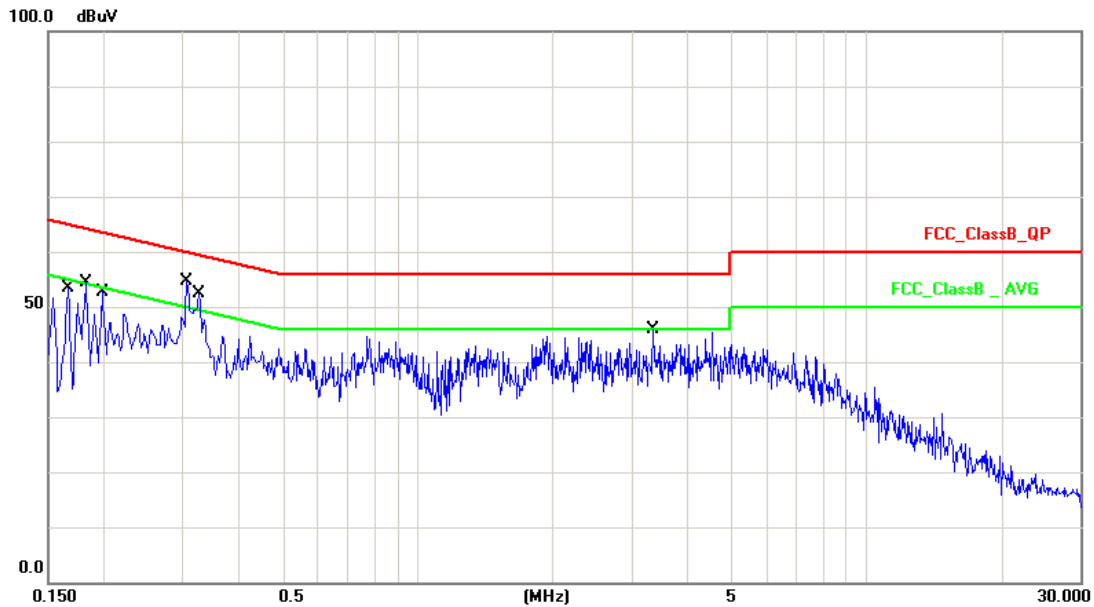

No.	Frequency (MHz)	Factor (dB)	Reading (dBuV)	Level (dBuV)	Limit (dBuV)	Margin (dB)	Detector
1	0.1660	10.13	34.91	45.04	65.15	-20.11	QP
2	0.1660	10.13	6.27	16.40	55.15	-38.75	AVG
3	0.1819	10.13	32.74	42.87	64.39	-21.52	QP
4	0.1819	10.13	5.88	16.01	54.39	-38.38	AVG
5	0.1980	10.13	31.37	41.50	63.69	-22.19	QP
6	0.1980	10.13	7.17	17.30	53.69	-36.39	AVG
7	0.3060	10.14	33.18	43.32	60.08	-16.76	QP
8	0.3060	10.14	10.80	20.94	50.08	-29.14	AVG
9	0.3260	10.14	34.26	44.40	59.55	-15.15	QP
10	0.3260	10.14	12.75	22.89	49.55	-26.66	AVG
11	3.3540	10.21	22.83	33.04	56.00	-22.96	QP
12	3.3540	10.21	3.19	13.40	46.00	-32.60	AVG

Note: Measurement Level = Reading Level + Correct Factor



5. Test of Radiated Emission

5.1 Test Limit

In any 100kHz bandwidth outside the frequency band in which the spread spectrum or digitally modulated intentional radiator is operating, the radio frequency power that is produced by the intentional radiator shall be at least 20dB below that in the 100kHz bandwidth within the band that contains the highest level of the desired power, based on either an RF conducted or a radiated measurement. If the transmitter measurement is based on the maximum conducted output Average power, the attenuation required under this paragraph shall be 30dB instead of 20dB. In addition, radiated emissions which fall in section 15.205(a) the restricted bands must also comply with the radiated emission limit specified in section 15.209(a).

FREQUENCIES(MHz)	FIELD STRENGTH (microvolts/meter)	MEASUREMENT DISTANCE(meters)
0.009~0.490	2400/F(kHz)	300
0.490~1.705	24000/F(kHz)	30
1.705~30.0	30	30
30~88	100	3
88~216	150	3
216~960	200	3
Above 960	500	3

5.2 Test Procedures

KDB 558074 D01v03r05 - Section 12.0 & Section 12.1



5.3 Test Setting

Quasi-Peak Measurements below 1GHz

1. Analyzer center frequency was set to the frequency of the radiated spurious emission of interest
2. Span was set greater than 1MHz
3. RBW = 120 kHz
4. Detector = CISPR quasi-peak
5. Sweep time = auto couple
6. Trace was allowed to stabilize

Peak Measurements above 1GHz

1. Analyzer center frequency was set to the frequency of the radiated spurious emission of interest
2. RBW = 1MHz
3. VBW = 3MHz
4. Detector = peak
5. Sweep time = auto couple
6. Trace mode = max hold
7. Trace was allowed to stabilize

Average Measurements above 1GHz

7.8.3. Average Field Strength Measurements

1. Analyzer center frequency was set to the frequency of the radiated spurious emission of interest
2. RBW = 1MHz
3. VBW = 10Hz (Duty Cycle=100%)
4. De As an alternative, the instrument may be set to linear detector mode. Ensure that video filtering is applied in linear voltage domain (rather than in a log or dB domain). Some instruments require linear display mode in order to accomplish this. Others have a setting for Average-VBW Type, which can be set to "Voltage" regardless of the display mode
5. Detector = Peak
6. Sweep time = auto
7. Trace mode = max hold
8. Allow max hold to run for at least 50 times (1/duty cycle) traces



5.4 Typical Test Setup

9kHz~30MHz Test Setup

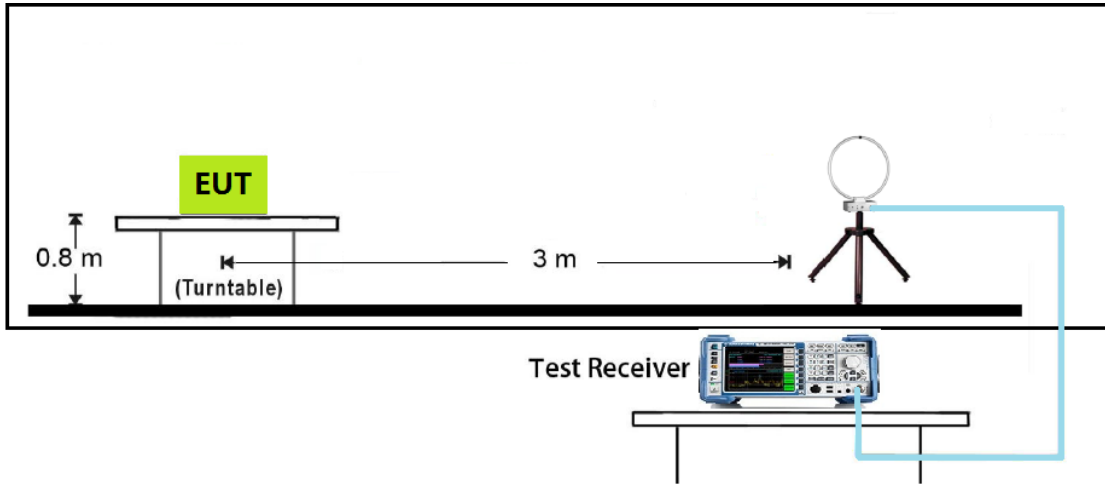

Below 1GHz Test Setup

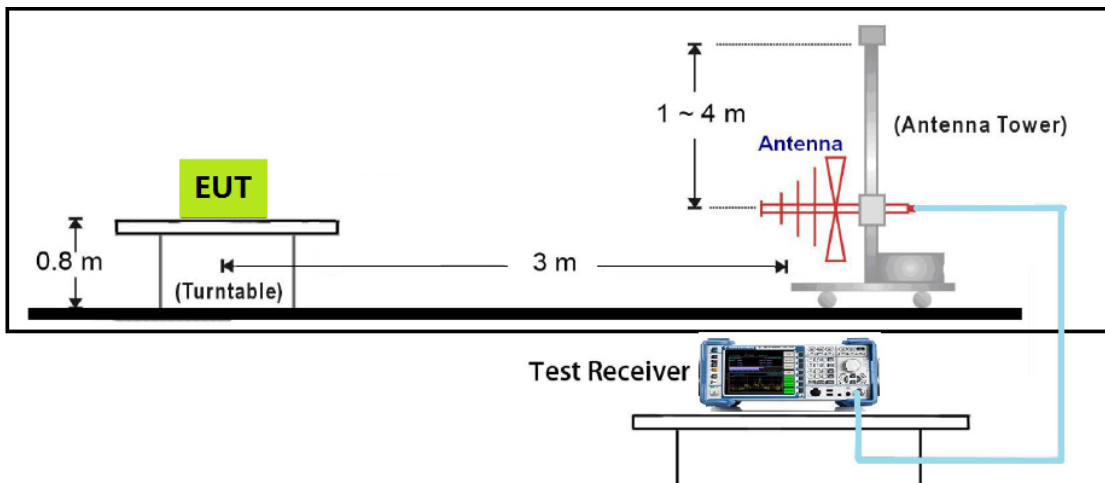



1GHz~18GHz Test Setup

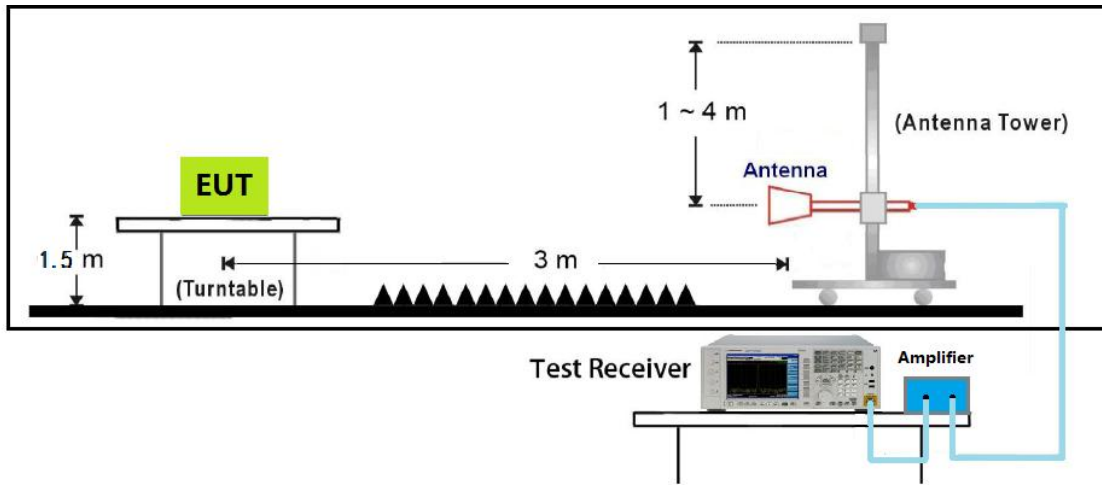

18GHz~40GHz Test Setup

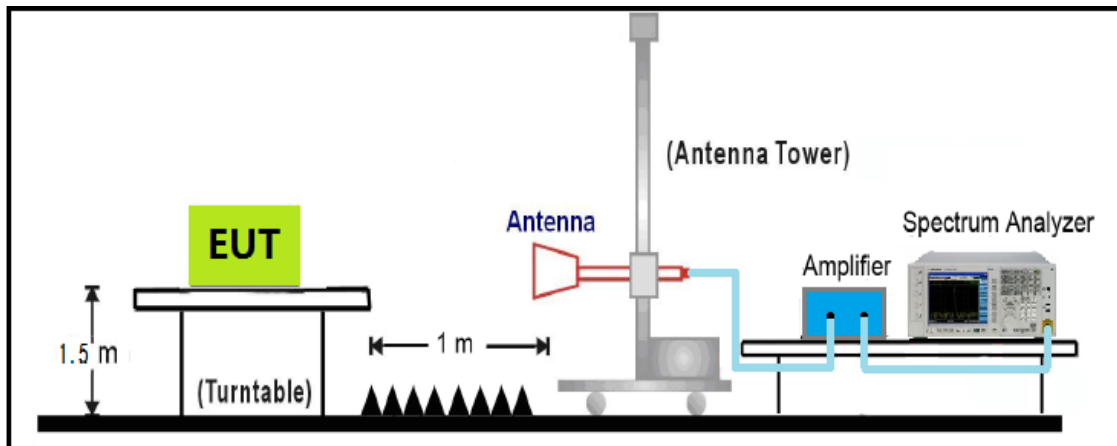

**5.5 Measurement Equipment**

Instrument/Ancillary	Manufacturer	Model No.	Serial No.	Calibration Date	Valid Date.
EMI Test Receiver	R&S	ESCI	101183	2016.03.28	2017.03.29
Spectrum Analyzer	N9010A	Agilent	MY53400169	2015.11.11	2016.11.11
Spectrum Analyzer	R&S	FSP40	100324	2016.03.23	2017.03.24
H64 Preamplifier	HP	8447F	3113A05582	2016.03.24	2017.03.23
Preamplifier	songyi	EM330	60618	2016.03.29	2017.03.28
Preamplifier	Agilent	8449B	3008A02342	2016.03.29	2017.03.28
Preamplifier	COM-POWER	PA-840	711885	2016.03.29	2017.03.28
Loop Antenna	R&S	HFH2-Z2	100150	2015.09.10	2016.09.09
Bilog Antenna	Sunol Science	JB1	A072414-1	2016.04.22	2017.04.21
Broad-Band Horn Antenna	Schwarzbeck	BBHA9120D	9120D-619	2016.04.20	2017.04.19
Broad-Band Horn Antenna	Schwarzbeck	BBHA9170	9170-347	2016.04.20	2017.04.19
Temperature/ Humidity Meter	Zhicheng	ZC1-11	CEP-TH-002	2016.03.31	2017.03.30
EZ-EMC	Fala	Ver CT3A1	N/A	N/A	N/A



5.6 Test Result and Data

The worst case of Radiated Emission below 1GHz:

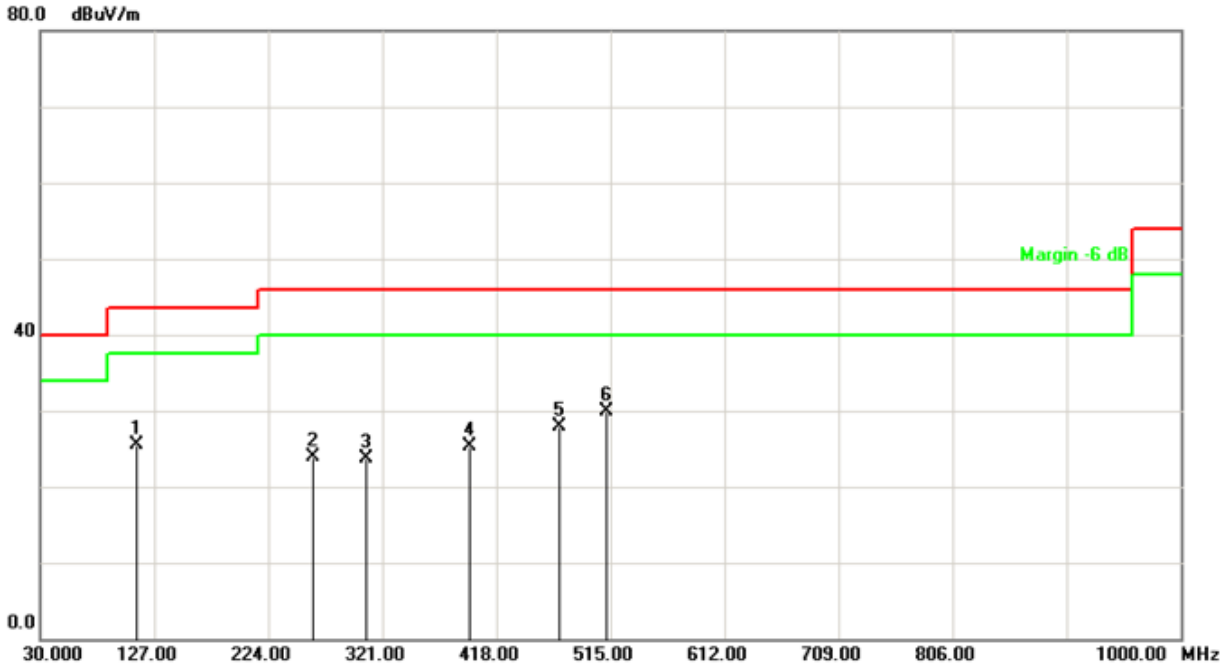

Test Standard:	FCC-part15.209	Ant. Polarization:	Horizontal
Test item:	Radiation Emission	Test Time:	2016.08.05
Product:	1080P Pan/Tilt Wireless IP Camera;720P Pan/Tilt Wireless IP Camera	Power Rating:	AC 120V/60Hz
Test Mode:	Transmit at 2437MHz by 802.11b	Temp.(C)/Hum.(%):	26()/60%

No.	Frequency (MHz)	Factor (dB/m)	Reading (dBuV)	Level (dBuV/m)	Limit (dBuV/m)	Margin (dB)	Det.
1	111.4800	-13.99	39.47	25.48	43.50	-18.02	QP
2	261.8299	-12.29	36.13	23.84	46.00	-22.16	QP
3	307.4200	-10.65	34.45	23.80	46.00	-22.20	QP
4	395.6899	-7.70	33.00	25.30	46.00	-20.70	QP
5	471.3500	-5.60	33.53	27.93	46.00	-18.07	QP
6	511.1200	-4.58	34.53	29.95	46.00	-16.05	QP

Note: Measure Level (dBuV/m) = Reading Level (dBuV) + Factor (dB)

Factor (dB) = Cable Loss (dB) + Antenna Factor (dB/m) - Pre_Amplifier Gain (dB)

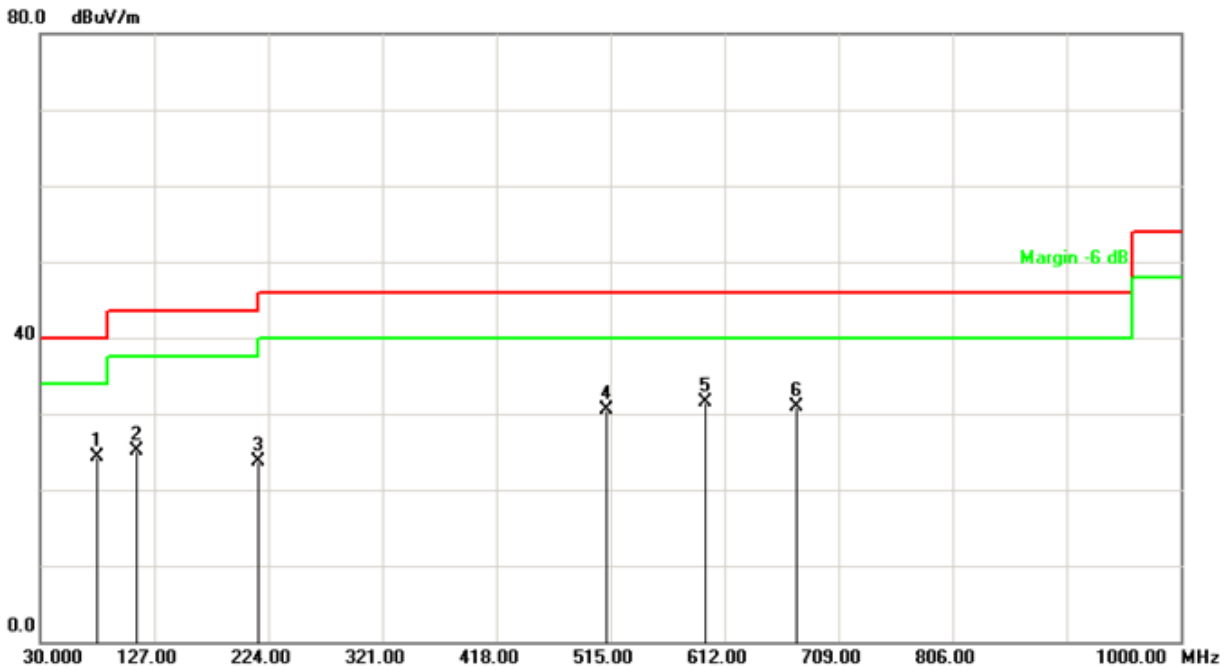

Test Standard:	FCC-part15.209	Ant. Polarization:	Vertical
Test item:	Radiation Emission	Test Time:	2016.08.05
Product:	1080P Pan/Tilt Wireless IP Camera;720P Pan/Tilt Wireless IP Camera	Power Rating:	AC 120V/60Hz
Test Mode:	Transmit at 2437MHz by 802.11b	Temp.(C)/Hum.(%):	26()/60%

No.	Frequency (MHz)	Factor (dB/m)	Reading (dBuV)	Level (dBuV/m)	Limit (dBuV/m)	Margin (dB)	Det.
1	78.5000	-15.79	40.18	24.39	40.00	-15.61	QP
2	111.4800	-13.99	39.01	25.02	43.50	-18.48	QP
3	215.2700	-14.47	38.14	23.67	43.50	-19.83	QP
4	511.1200	-4.58	35.12	30.54	46.00	-15.46	QP
5	595.5099	-2.75	34.17	31.42	46.00	-14.58	QP
6	673.1100	-1.10	31.98	30.88	46.00	-15.12	QP

Note: Measure Level (dBuV/m) = Reading Level (dBuV) + Factor (dB)

Factor (dB) = Cable Loss (dB) + Antenna Factor (dB/m) - Pre_Amplifier Gain (dB)



Above 1GHz

Site: AC102	Time: 2016/08/01 - 19:17
Limit: FCC_Part15.209_RE(3m)	Margin: 0
Probe:BBHA9120D(1-18GHz)	Polarity: Horizontal
EUT: 1080P Pan/Tilt Wireless IP Camera;720P Pan/Tilt Wireless IP Camera	Power: AC 120V/60Hz
Note: Mode 1: Transmit at channel 2412MHz by 802.11b	

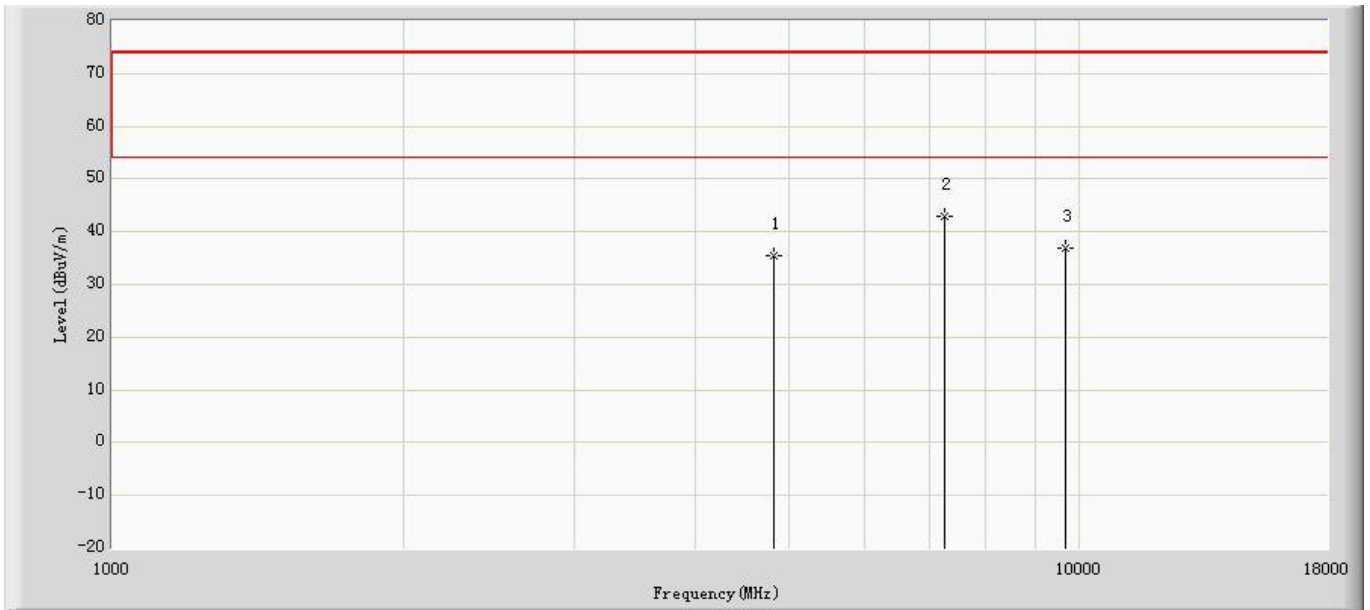

No	Mark	Frequency (MHz)	Measure Level (dBuV/m)	Reading Level (dBuV)	Over Limit (dB)	Limit (dBuV/m)	Factor (dB)	Type
1		4824.000	35.538	28.786	-38.462	74.000	6.753	PK
2	*	7236.000	42.852	33.876	-31.148	74.000	8.976	PK
3		9648.000	37.008	26.545	-36.992	74.000	10.463	PK

Note: Measure Level (dBuV/m) = Reading Level (dBuV) + Factor (dB)

Factor (dB) = Cable Loss (dB) + Antenna Factor (dB/m) - Pre_Amplifier Gain (dB)



Site: AC102	Time: 2016/08/01 - 19:17
Limit: FCC_Part15.209_RE(3m)	Margin: 0
Probe:BBHA9120D(1-18GHz)	Polarity: Vertical
EUT: 1080P Pan/Tilt Wireless IP Camera;720P Pan/Tilt Wireless IP Camera	Power: AC 120V/60Hz
Note: Mode 1: Transmit at channel 2412MHz by 802.11b	

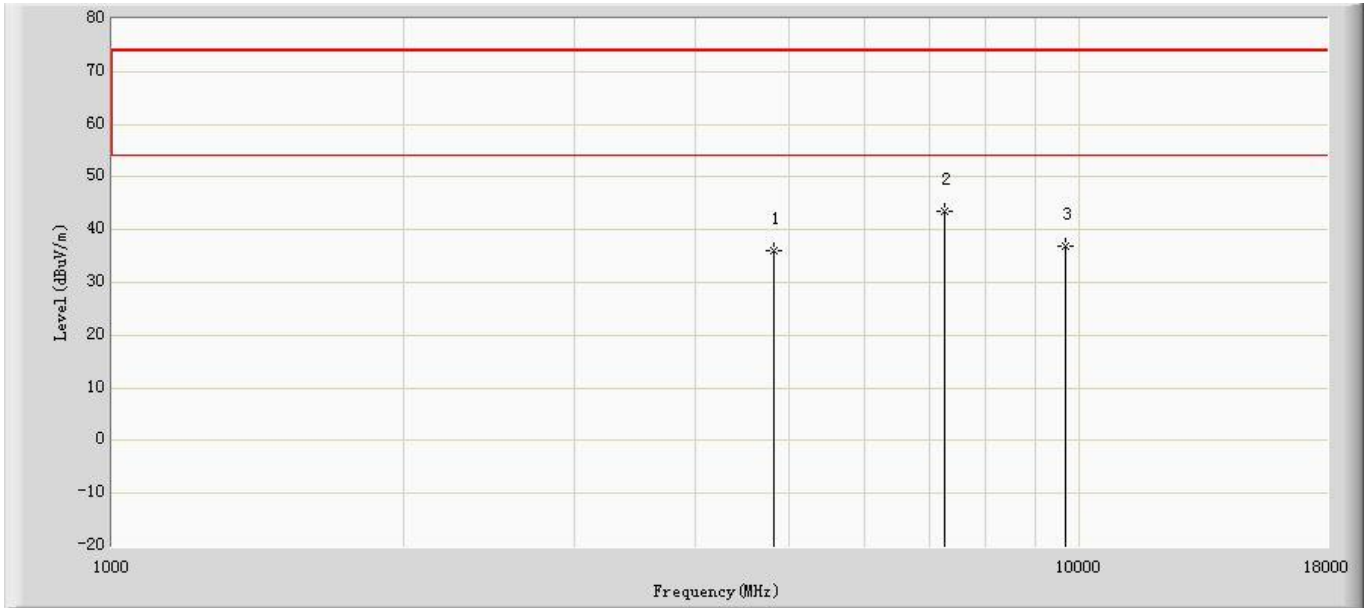

No	Mark	Frequency (MHz)	Measure Level (dBuV/m)	Reading Level (dBuV)	Over Limit (dB)	Limit (dBuV/m)	Factor (dB)	Type
1		4824.000	35.996	29.244	-38.004	74.000	6.753	PK
2	*	7236.000	43.382	34.406	-30.618	74.000	8.976	PK
3		9648.000	36.855	26.392	-37.145	74.000	10.463	PK

Note: Measure Level (dBuV/m) = Reading Level (dBuV) + Factor (dB)

Factor (dB) = Cable Loss (dB) + Antenna Factor (dB/m) - Pre_Amplifier Gain (dB)



Site: AC102	Time: 2016/08/01 - 19:17
Limit: FCC_Part15.209_RE(3m)	Margin: 0
Probe:BBHA9120D(1-18GHz)	Polarity: Horizontal
EUT: 1080P Pan/Tilt Wireless IP Camera;720P Pan/Tilt Wireless IP Camera	Power: AC 120V/60Hz
Note: Mode 1: Transmit at channel 2437MHz by 802.11b	

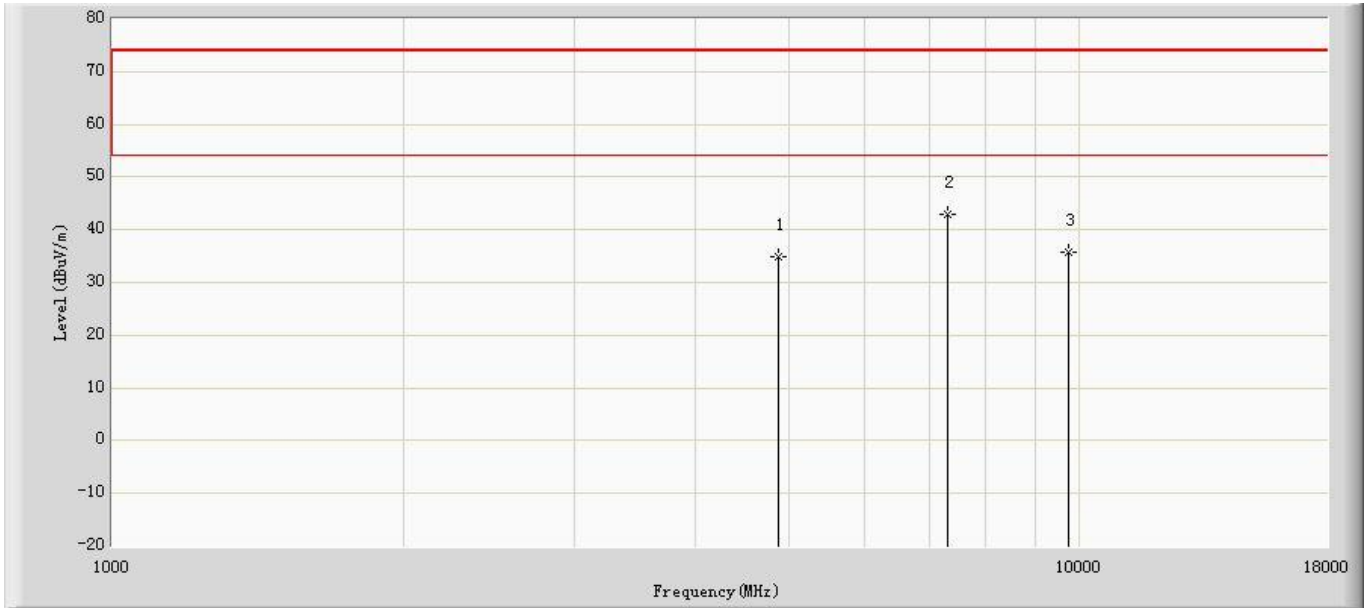

No	Mark	Frequency (MHz)	Measure Level (dBuV/m)	Reading Level (dBuV)	Over Limit (dB)	Limit (dBuV/m)	Factor (dB)	Type
1		4874.000	34.935	28.094	-39.065	74.000	6.841	PK
2	*	7311.000	42.998	33.916	-31.002	74.000	9.082	PK
3		9748.000	35.760	25.148	-38.240	74.000	10.612	PK

Note: Measure Level (dBuV/m) = Reading Level (dBuV) + Factor (dB)

Factor (dB) = Cable Loss (dB) + Antenna Factor (dB/m) - Pre_Amplifier Gain (dB)



Site: AC102	Time: 2016/08/01 - 19:17
Limit: FCC_Part15.209_RE(3m)	Margin: 0
Probe:BBHA9120D(1-18GHz)	Polarity: Vertical
EUT: 1080P Pan/Tilt Wireless IP Camera;720P Pan/Tilt Wireless IP Camera	Power: AC 120V/60Hz
Note: Mode 1: Transmit at channel 2437MHz by 802.11b	

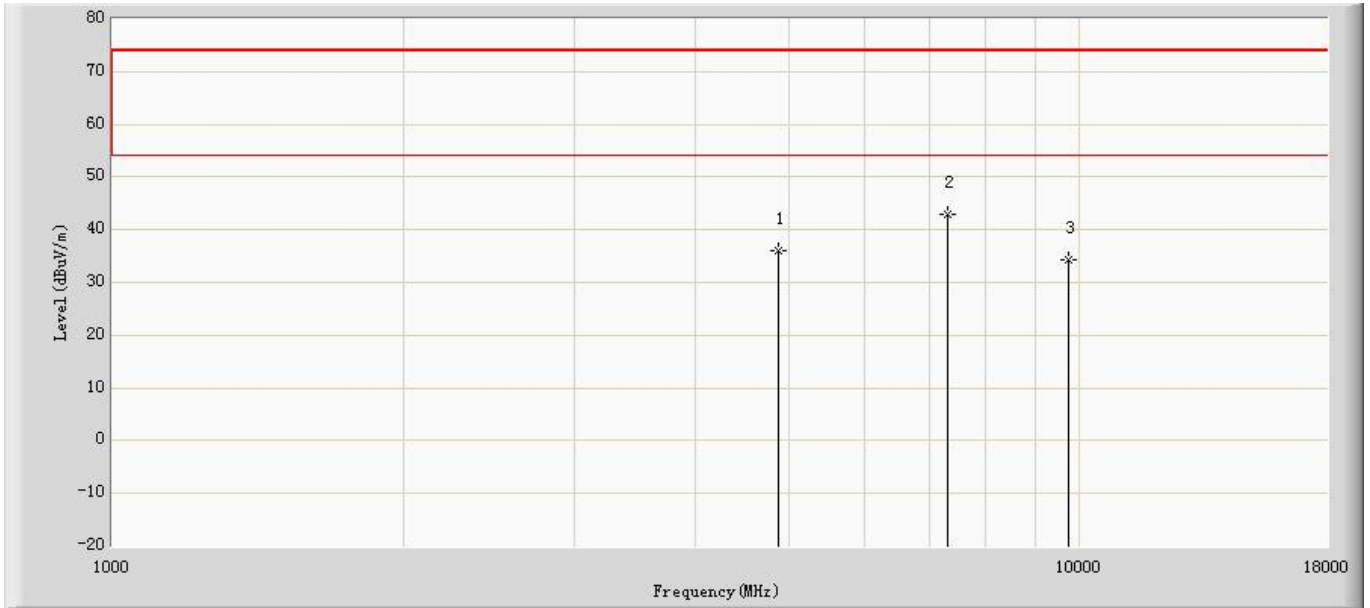

No	Mark	Frequency (MHz)	Measure Level (dBuV/m)	Reading Level (dBuV)	Over Limit (dB)	Limit (dBuV/m)	Factor (dB)	Type
1		4874.000	35.976	29.135	-38.024	74.000	6.841	PK
2	*	7311.000	43.059	33.977	-30.941	74.000	9.082	PK
3		9748.000	34.211	23.599	-39.789	74.000	10.612	PK

Note: Measure Level (dBuV/m) = Reading Level (dBuV) + Factor (dB)

Factor (dB) = Cable Loss (dB) + Antenna Factor (dB/m) - Pre_Amplifier Gain (dB)



Site: AC102	Time: 2016/08/01 - 19:17
Limit: FCC_Part15.209_RE(3m)	Margin: 0
Probe:BBHA9120D(1-18GHz)	Polarity: Horizontal
EUT: 1080P Pan/Tilt Wireless IP Camera;720P Pan/Tilt Wireless IP Camera	Power: AC 120V/60Hz
Note: Mode 1: Transmit at channel 2462MHz by 802.11b	

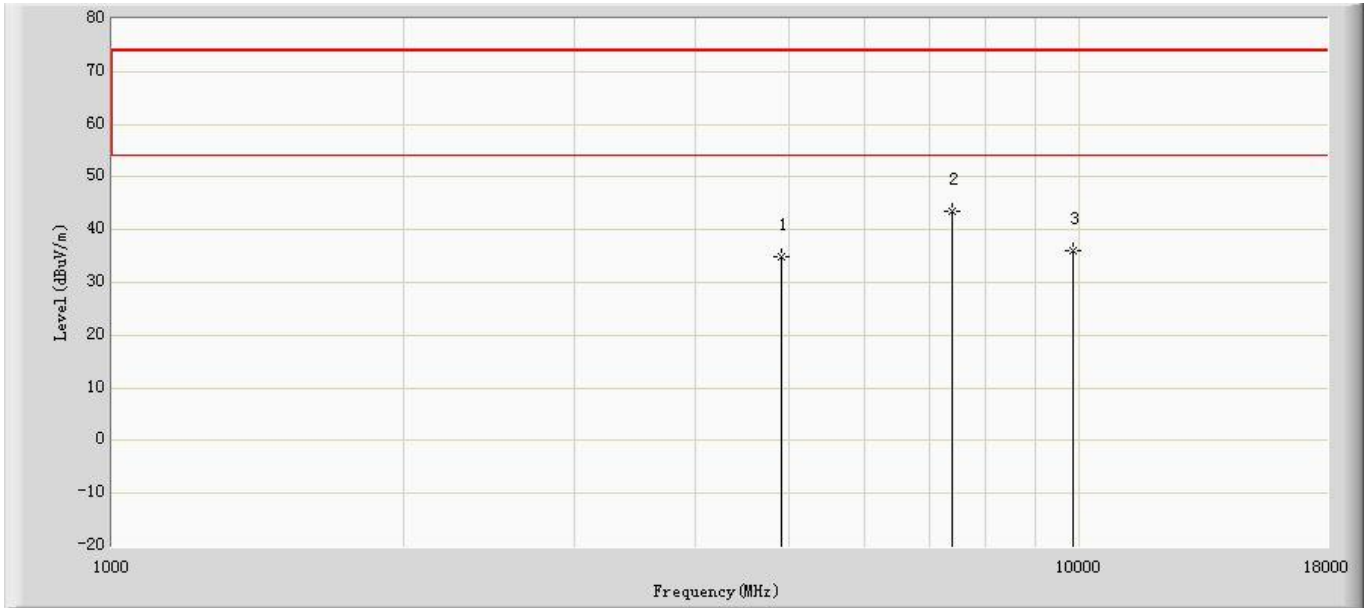

No	Mark	Frequency (MHz)	Measure Level (dBuV/m)	Reading Level (dBuV)	Over Limit (dB)	Limit (dBuV/m)	Factor (dB)	Type
1		4924.000	34.744	27.749	-39.256	74.000	6.995	PK
2	*	7386.000	43.384	34.208	-30.616	74.000	9.176	PK
3		9848.000	36.018	25.262	-37.982	74.000	10.756	PK

Note: Measure Level (dBuV/m) = Reading Level (dBuV) + Factor (dB)

Factor (dB) = Cable Loss (dB) + Antenna Factor (dB/m) - Pre_Amplifier Gain (dB)



Site: AC102	Time: 2016/08/01 - 19:17
Limit: FCC_Part15.209_RE(3m)	Margin: 0
Probe:BBHA9120D(1-18GHz)	Polarity: Vertical
EUT: 1080P Pan/Tilt Wireless IP Camera;720P Pan/Tilt Wireless IP Camera	Power: AC 120V/60Hz
Note: Mode 1: Transmit at channel 2462MHz by 802.11b	

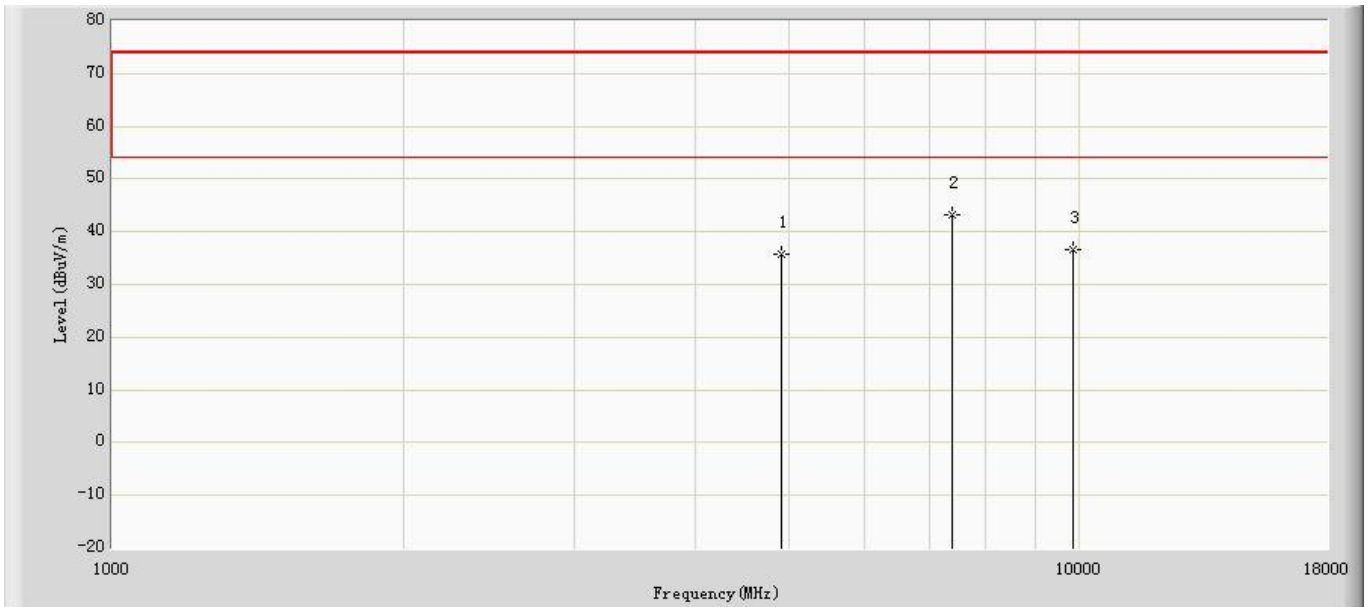

No	Mark	Frequency (MHz)	Measure Level (dBuV/m)	Reading Level (dBuV)	Over Limit (dB)	Limit (dBuV/m)	Factor (dB)	Type
1		4924.000	35.711	28.716	-38.289	74.000	6.995	PK
2	*	7386.000	43.204	34.028	-30.796	74.000	9.176	PK
3		9848.000	36.546	25.790	-37.454	74.000	10.756	PK

Note: Measure Level (dBuV/m) = Reading Level (dBuV) + Factor (dB)

Factor (dB) = Cable Loss (dB) + Antenna Factor (dB/m) - Pre_Amplifier Gain (dB)



Site: AC102	Time: 2016/08/01 - 19:17
Limit: FCC_Part15.209_RE(3m)	Margin: 0
Probe:BBHA9120D(1-18GHz)	Polarity: Horizontal
EUT: 1080P Pan/Tilt Wireless IP Camera;720P Pan/Tilt Wireless IP Camera	Power: AC 120V/60Hz
Note: Mode 2: Transmit at channel 2412MHz by 802.11g	

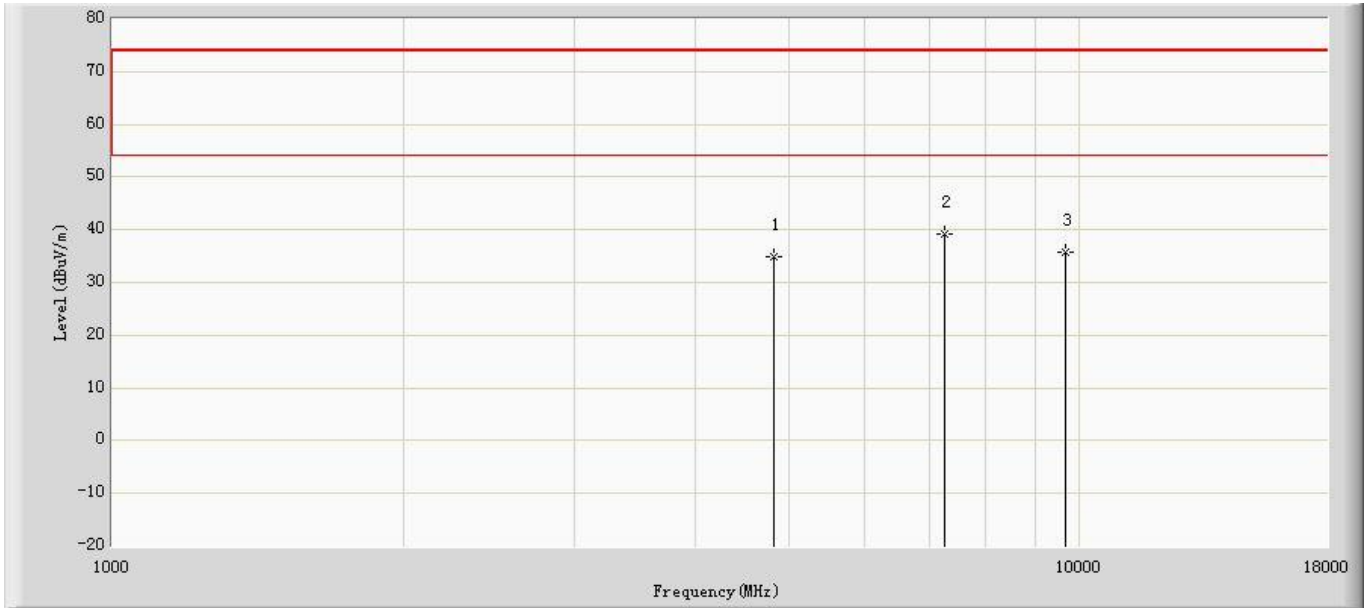

No	Mark	Frequency (MHz)	Measure Level (dBuV/m)	Reading Level (dBuV)	Over Limit (dB)	Limit (dBuV/m)	Factor (dB)	Type
1		4824.000	34.981	28.229	-39.019	74.000	6.753	PK
2	*	7236.000	39.100	30.124	-34.900	74.000	8.976	PK
3		9648.000	35.878	25.415	-38.122	74.000	10.463	PK

Note: Measure Level (dBuV/m) = Reading Level (dBuV) + Factor (dB)

Factor (dB) = Cable Loss (dB) + Antenna Factor (dB/m) - Pre_Amplifier Gain (dB)



Site: AC102	Time: 2014/10/30 - 14:51
Limit: FCC_Part15.209_RE(3m)	Margin: 0
Probe:BBHA9120D(1-18GHz)	Polarity: Vertical
EUT: 1080P Pan/Tilt Wireless IP Camera;720P Pan/Tilt Wireless IP Camera	Power: AC 120V/60Hz
Note: Mode 2: Transmit at channel 2412MHz by 802.11g	

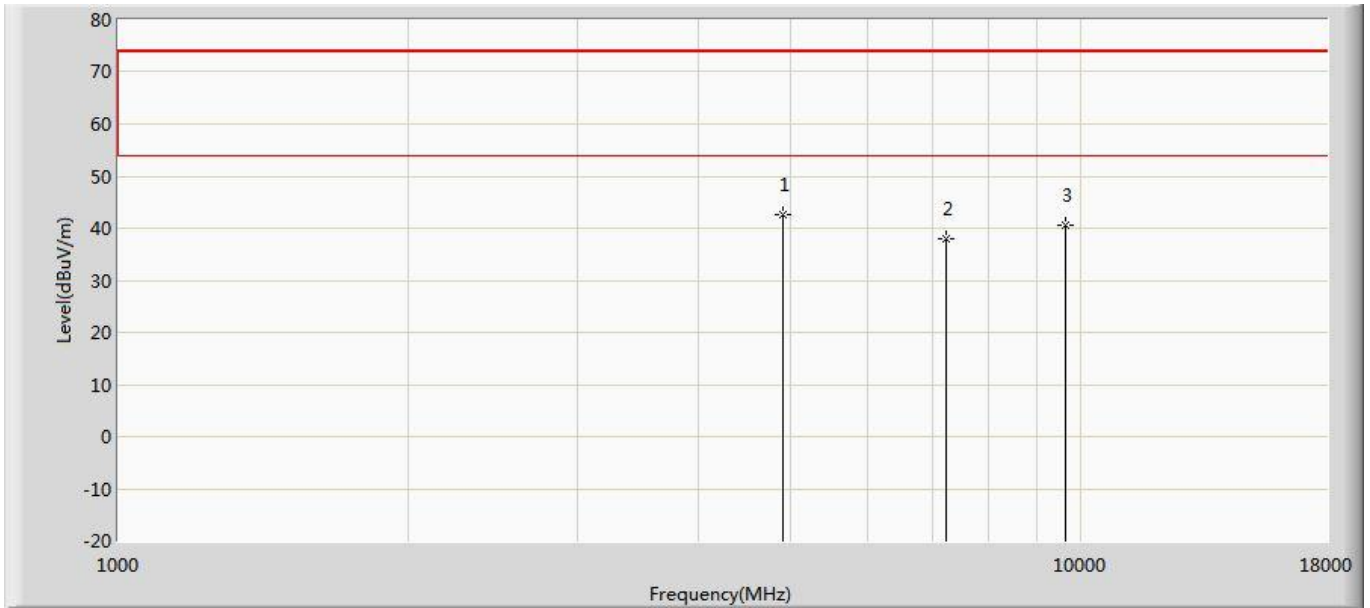

No	Mark	Frequency (MHz)	Measure Level (dBuV/m)	Reading Level (dBuV)	Over Limit (dB)	Limit (dBuV/m)	Factor (dB)	Type
1	*	4910.000	42.663	32.260	-31.337	74.000	10.403	PK
2		7236.000	37.967	26.096	-36.033	74.000	11.871	PK
3		9648.000	40.650	26.681	-33.350	74.000	13.970	PK

Note: Measure Level (dBuV/m) = Reading Level (dBuV) + Factor (dB)

Factor (dB) = Cable Loss (dB) + Antenna Factor (dB/m) - Pre_Amplifier Gain (dB)



Site: AC102	Time: 2016/08/01 - 19:17
Limit: FCC_Part15.209_RE(3m)	Margin: 0
Probe:BBHA9120D(1-18GHz)	Polarity: Horizontal
EUT: 1080P Pan/Tilt Wireless IP Camera;720P Pan/Tilt Wireless IP Camera	Power: AC 120V/60Hz
Note: Mode 2: Transmit at channel 2437MHz by 802.11g	

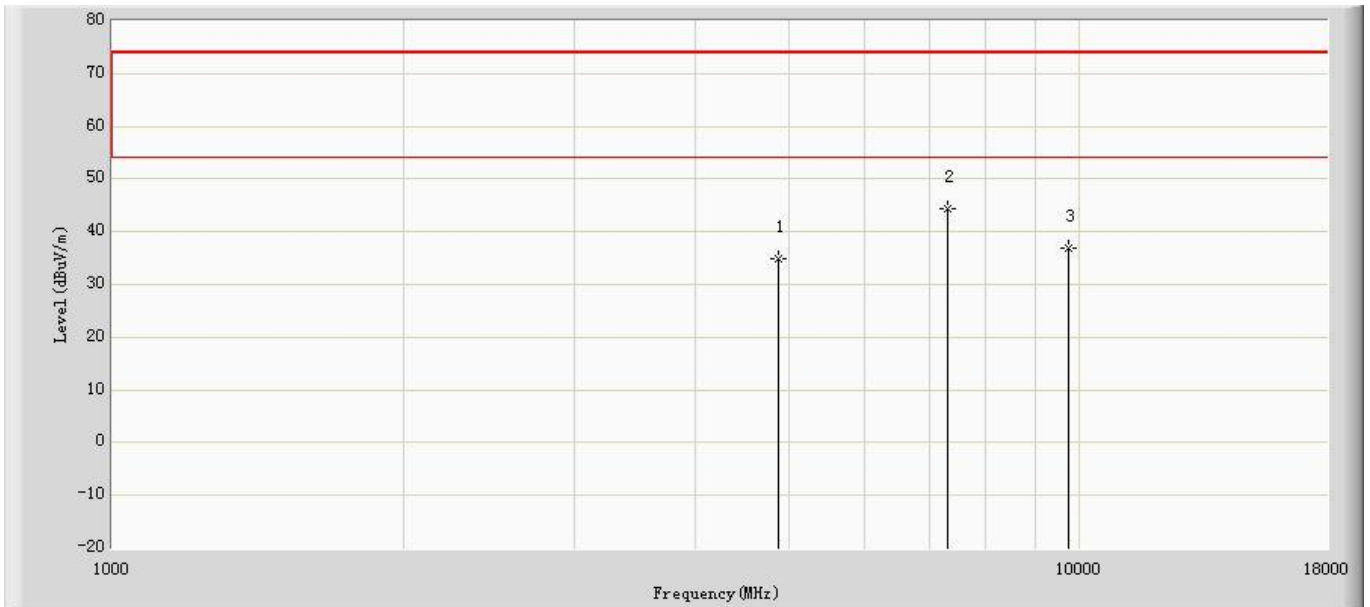

No	Mark	Frequency (MHz)	Measure Level (dBuV/m)	Reading Level (dBuV)	Over Limit (dB)	Limit (dBuV/m)	Factor (dB)	Type
1		4874.000	34.974	28.133	-39.026	74.000	6.841	PK
2	*	7311.000	44.325	35.243	-29.675	74.000	9.082	PK
3		9748.000	37.038	26.426	-36.962	74.000	10.612	PK

Note: Measure Level (dBuV/m) = Reading Level (dBuV) + Factor (dB)

Factor (dB) = Cable Loss (dB) + Antenna Factor (dB/m) - Pre_Amplifier Gain (dB)



Site: AC102	Time: 2016/08/01 - 19:17
Limit: FCC_Part15.209_RE(3m)	Margin: 0
Probe:BBHA9120D(1-18GHz)	Polarity: Vertical
EUT: 1080P Pan/Tilt Wireless IP Camera;720P Pan/Tilt Wireless IP Camera	Power: AC 120V/60Hz
Note: Mode 2: Transmit at channel 2437MHz by 802.11g	

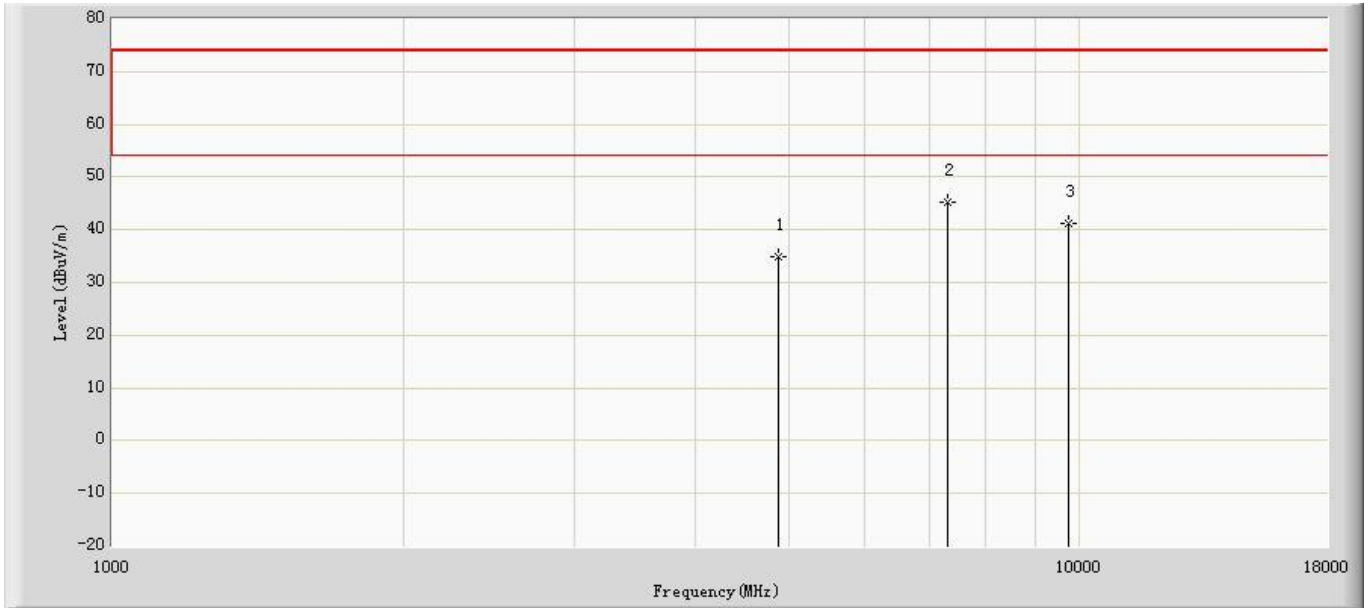

No	Mark	Frequency (MHz)	Measure Level (dBuV/m)	Reading Level (dBuV)	Over Limit (dB)	Limit (dBuV/m)	Factor (dB)	Type
1		4874.000	35.020	28.179	-38.980	74.000	6.841	PK
2	*	7311.000	45.318	36.236	-28.682	74.000	9.082	PK
3		9748.000	41.107	30.495	-32.893	74.000	10.612	PK

Note: Measure Level (dBuV/m) = Reading Level (dBuV) + Factor (dB)

Factor (dB) = Cable Loss (dB) + Antenna Factor (dB/m) - Pre_Amplifier Gain (dB)



Site: AC102	Time: 2016/08/01 - 19:18
Limit: FCC_Part15.209_RE(3m)	Margin: 0
Probe:BBHA9120D(1-18GHz)	Polarity: Horizontal
EUT: 1080P Pan/Tilt Wireless IP Camera;720P Pan/Tilt Wireless IP Camera	Power: AC 120V/60Hz
Note: Mode 2: Transmit at channel 2462MHz by 802.11g	

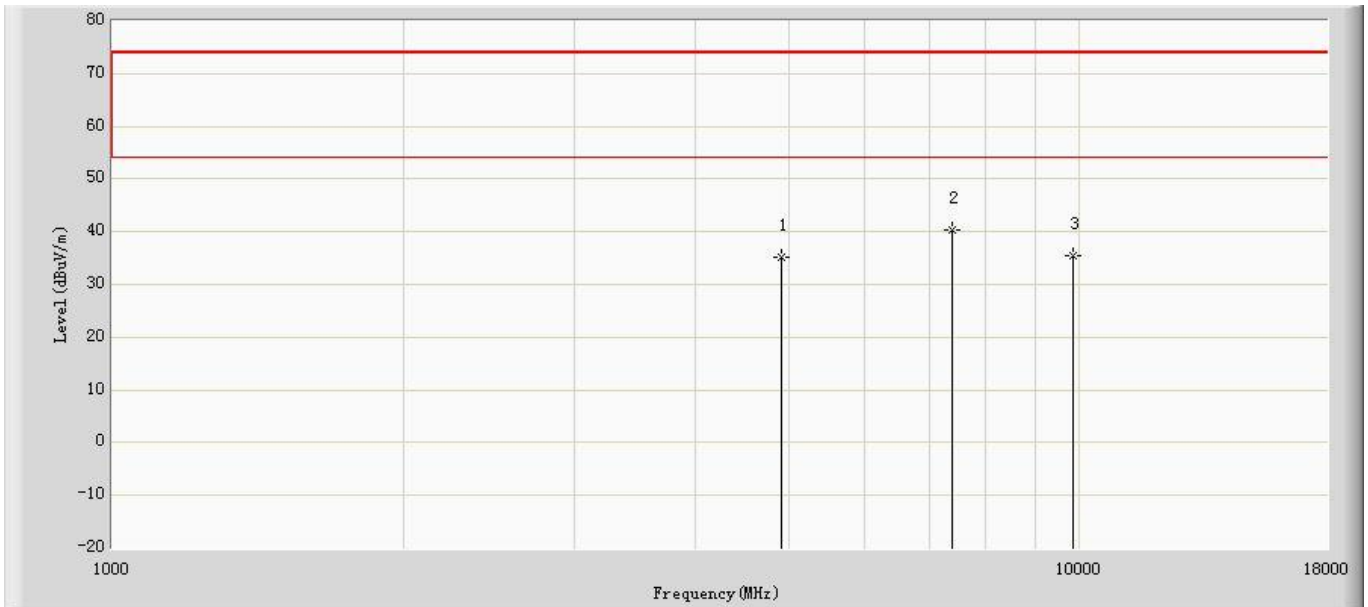

No	Mark	Frequency (MHz)	Measure Level (dBuV/m)	Reading Level (dBuV)	Over Limit (dB)	Limit (dBuV/m)	Factor (dB)	Type
1		4924.000	35.230	28.235	-38.770	74.000	6.995	PK
2	*	7386.000	40.363	31.187	-33.637	74.000	9.176	PK
3		9848.000	35.494	24.738	-38.506	74.000	10.756	PK

Note: Measure Level (dBuV/m) = Reading Level (dBuV) + Factor (dB)

Factor (dB) = Cable Loss (dB) + Antenna Factor (dB/m) - Pre_Amplifier Gain (dB)



Site: AC102	Time: 2016/08/01 - 19:18
Limit: FCC_Part15.209_RE(3m)	Margin: 0
Probe:BBHA9120D(1-18GHz)	Polarity: Vertical
EUT: 1080P Pan/Tilt Wireless IP Camera;720P Pan/Tilt Wireless IP Camera	Power: AC 120V/60Hz
Note: Mode 2: Transmit at channel 2462MHz by 802.11g	

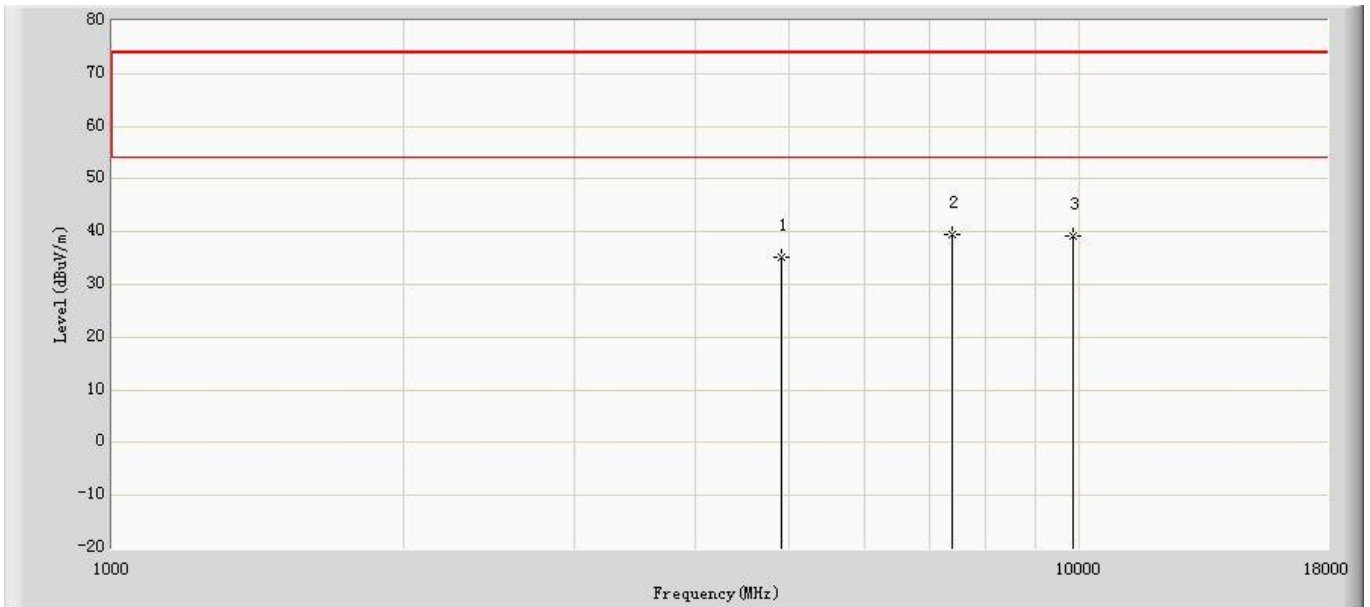

No	Mark	Frequency (MHz)	Measure Level (dBuV/m)	Reading Level (dBuV)	Over Limit (dB)	Limit (dBuV/m)	Factor (dB)	Type
1		4924.000	35.238	28.243	-38.762	74.000	6.995	PK
2	*	7386.000	39.384	30.208	-34.616	74.000	9.176	PK
3		9848.000	39.127	28.371	-34.873	74.000	10.756	PK

Note: Measure Level (dBuV/m) = Reading Level (dBuV) + Factor (dB)

Factor (dB) = Cable Loss (dB) + Antenna Factor (dB/m) - Pre_Amplifier Gain (dB)



Site: AC102	Time: 2016/08/01 - 19:18
Limit: FCC_Part15.209_RE(3m)	Margin: 0
Probe:BBHA9120D(1-18GHz)	Polarity: Horizontal
EUT: 1080P Pan/Tilt Wireless IP Camera;720P Pan/Tilt Wireless IP Camera	Power: AC 120V/60Hz
Note: Mode 3: Transmit at channel 2412MHz by 802.11n20	

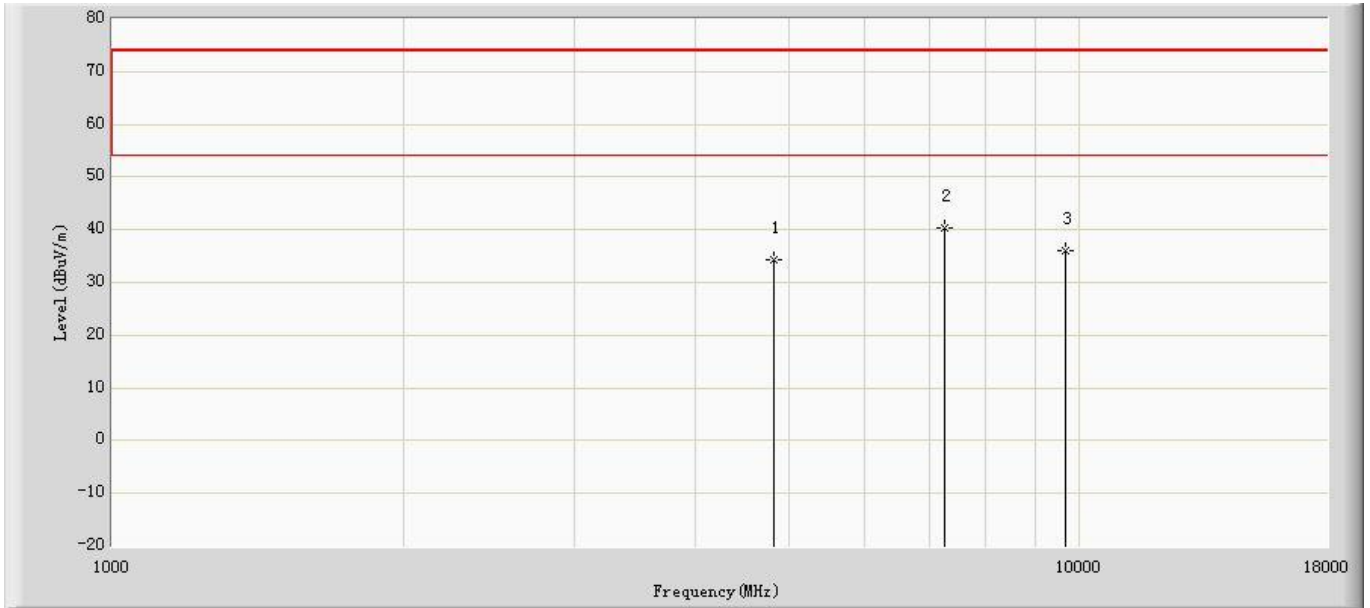

No	Mark	Frequency (MHz)	Measure Level (dBuV/m)	Reading Level (dBuV)	Over Limit (dB)	Limit (dBuV/m)	Factor (dB)	Type
1		4824.000	34.409	27.657	-39.591	74.000	6.753	PK
2	*	7236.000	40.220	31.244	-33.780	74.000	8.976	PK
3		9648.000	35.916	25.453	-38.084	74.000	10.463	PK

Note: Measure Level (dBuV/m) = Reading Level (dBuV) + Factor (dB)

Factor (dB) = Cable Loss (dB) + Antenna Factor (dB/m) - Pre_Amplifier Gain (dB)



Site: AC102	Time: 2016/08/01 - 19:18
Limit: FCC_Part15.209_RE(3m)	Margin: 0
Probe:BBHA9120D(1-18GHz)	Polarity: Vertical
EUT: 1080P Pan/Tilt Wireless IP Camera;720P Pan/Tilt Wireless IP Camera	Power: AC 120V/60Hz
Note: Mode 3: Transmit at channel 2412MHz by 802.11n20	

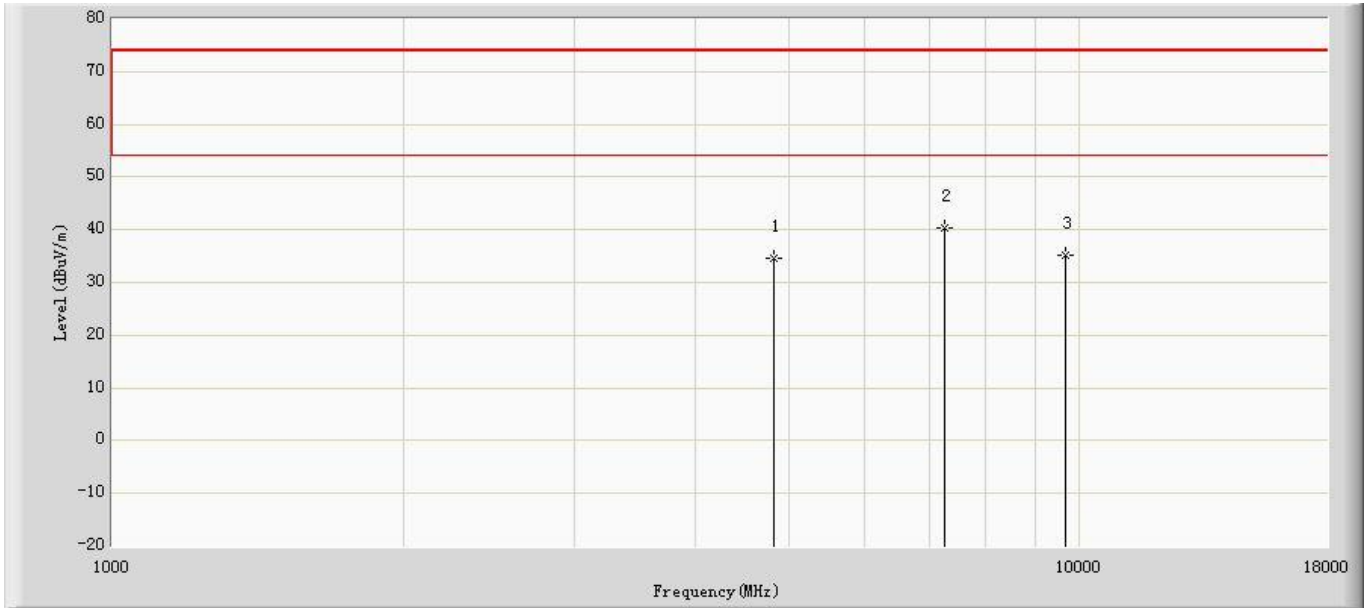

No	Mark	Frequency (MHz)	Measure Level (dBuV/m)	Reading Level (dBuV)	Over Limit (dB)	Limit (dBuV/m)	Factor (dB)	Type
1		4824.000	34.477	27.725	-39.523	74.000	6.753	PK
2	*	7236.000	40.329	31.353	-33.671	74.000	8.976	PK
3		9648.000	35.205	24.742	-38.795	74.000	10.463	PK

Note: Measure Level (dBuV/m) = Reading Level (dBuV) + Factor (dB)

Factor (dB) = Cable Loss (dB) + Antenna Factor (dB/m) - Pre_Amplifier Gain (dB)



Site: AC102	Time: 2016/08/01 - 19:18
Limit: FCC_Part15.209_RE(3m)	Margin: 0
Probe:BBHA9120D(1-18GHz)	Polarity: Horizontal
EUT: 1080P Pan/Tilt Wireless IP Camera;720P Pan/Tilt Wireless IP Camera	Power: AC 120V/60Hz
Note: Mode 3: Transmit at channel 2437MHz by 802.11n20	

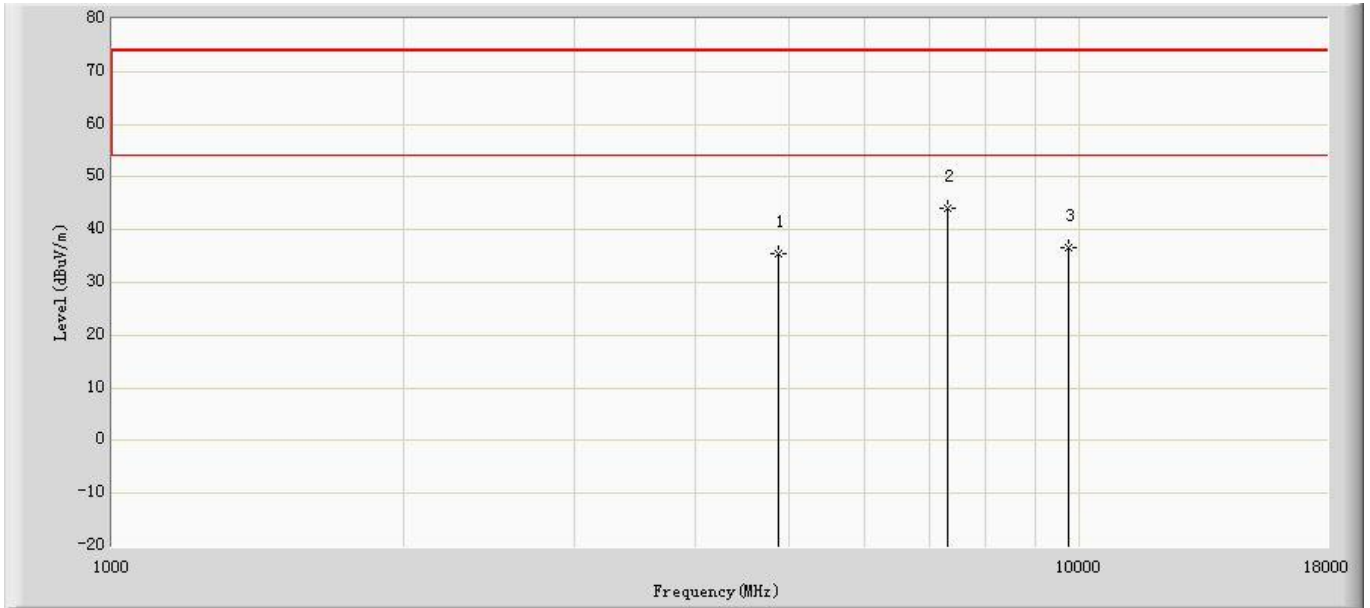

No	Mark	Frequency (MHz)	Measure Level (dBuV/m)	Reading Level (dBuV)	Over Limit (dB)	Limit (dBuV/m)	Factor (dB)	Type
1		4874.000	35.320	28.479	-38.680	74.000	6.841	PK
2	*	7311.000	44.160	35.078	-29.840	74.000	9.082	PK
3		9748.000	36.561	25.949	-37.439	74.000	10.612	PK

Note: Measure Level (dBuV/m) = Reading Level (dBuV) + Factor (dB)

Factor (dB) = Cable Loss (dB) + Antenna Factor (dB/m) - Pre_Amplifier Gain (dB)



Site: AC102	Time: 2016/08/01 - 19:18
Limit: FCC_Part15.209_RE(3m)	Margin: 0
Probe:BBHA9120D(1-18GHz)	Polarity: Vertical
EUT: 1080P Pan/Tilt Wireless IP Camera;720P Pan/Tilt Wireless IP Camera	Power: AC 120V/60Hz
Note: Mode 3: Transmit at channel 2437MHz by 802.11n20	

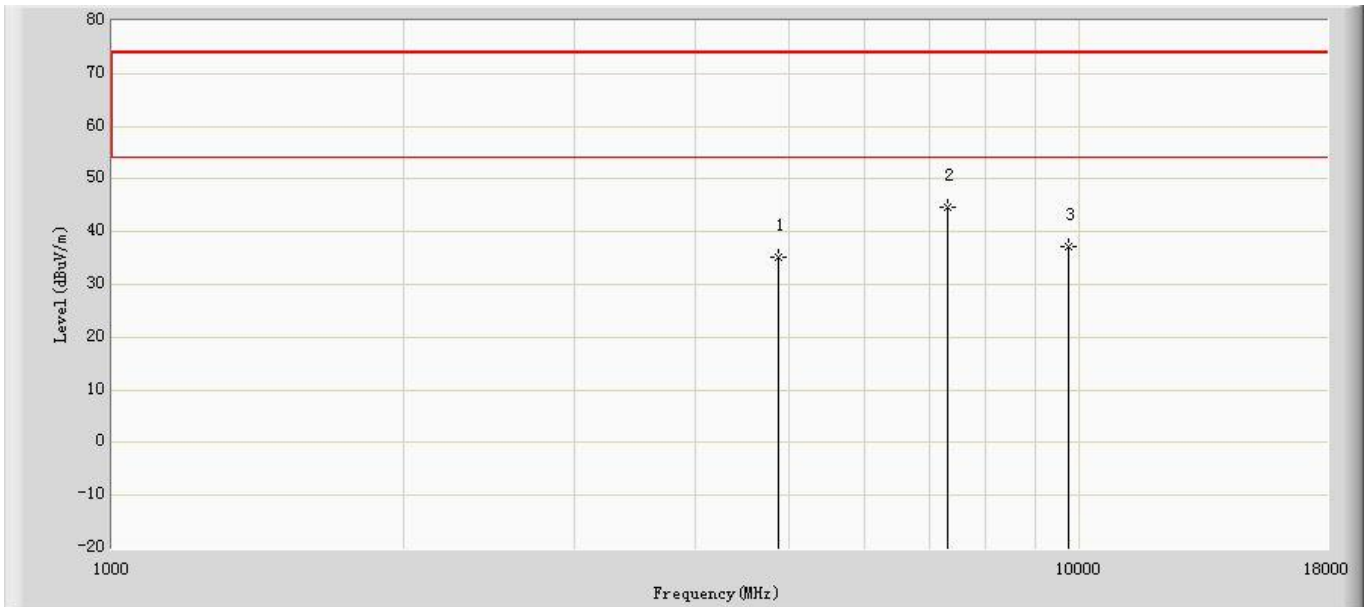

No	Mark	Frequency (MHz)	Measure Level (dBuV/m)	Reading Level (dBuV)	Over Limit (dB)	Limit (dBuV/m)	Factor (dB)	Type
1		4874.000	35.253	28.412	-38.747	74.000	6.841	PK
2	*	7311.000	44.731	35.649	-29.269	74.000	9.082	PK
3		9748.000	37.257	26.645	-36.743	74.000	10.612	PK

Note: Measure Level (dBuV/m) = Reading Level (dBuV) + Factor (dB)

Factor (dB) = Cable Loss (dB) + Antenna Factor (dB/m) - Pre_Amplifier Gain (dB)



Site: AC102	Time: 2016/08/01 - 19:18
Limit: FCC_Part15.209_RE(3m)	Margin: 0
Probe:BBHA9120D(1-18GHz)	Polarity: Horizontal
EUT: 1080P Pan/Tilt Wireless IP Camera;720P Pan/Tilt Wireless IP Camera	Power: AC 120V/60Hz
Note: Mode 3: Transmit at channel 2462MHz by 802.11n20	

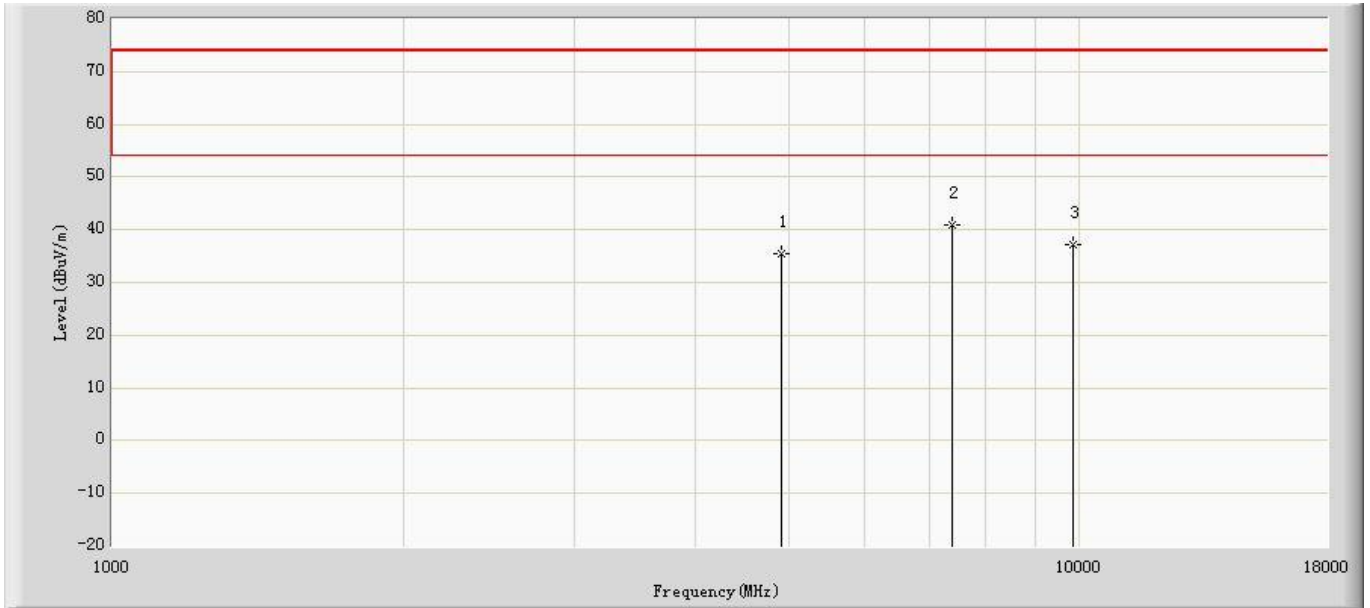

No	Mark	Frequency (MHz)	Measure Level (dBuV/m)	Reading Level (dBuV)	Over Limit (dB)	Limit (dBuV/m)	Factor (dB)	Type
1		4924.000	35.332	28.337	-38.668	74.000	6.995	PK
2	*	7386.000	40.972	31.796	-33.028	74.000	9.176	PK
3		9848.000	37.192	26.436	-36.808	74.000	10.756	PK

Note: Measure Level (dBuV/m) = Reading Level (dBuV) + Factor (dB)

Factor (dB) = Cable Loss (dB) + Antenna Factor (dB/m) - Pre_Amplifier Gain (dB)



Site: AC102	Time: 2016/08/01 - 19:18
Limit: FCC_Part15.209_RE(3m)	Margin: 0
Probe:BBHA9120D(1-18GHz)	Polarity: Vertical
EUT: 1080P Pan/Tilt Wireless IP Camera;720P Pan/Tilt Wireless IP Camera	Power: AC 120V/60Hz
Note: Mode 3: Transmit at channel 2462MHz by 802.11n20	

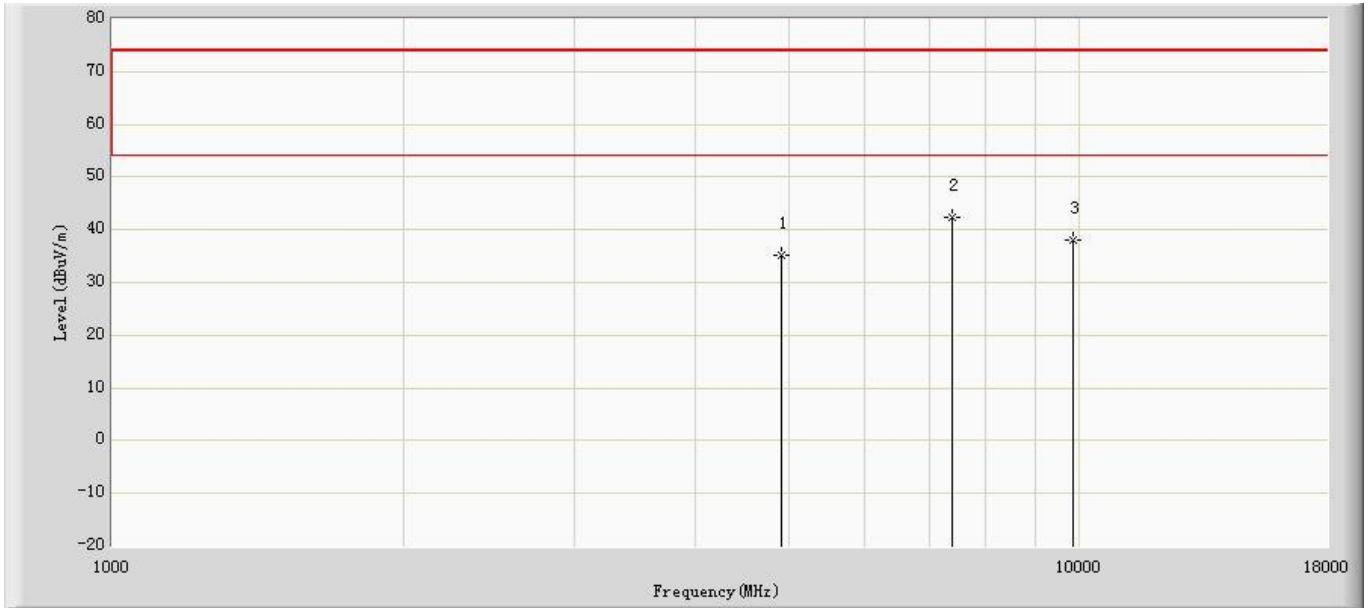

No	Mark	Frequency (MHz)	Measure Level (dBuV/m)	Reading Level (dBuV)	Over Limit (dB)	Limit (dBuV/m)	Factor (dB)	Type
1		4924.000	35.058	28.063	-38.942	74.000	6.995	PK
2	*	7386.000	42.316	33.140	-31.684	74.000	9.176	PK
3		9848.000	38.061	27.305	-35.939	74.000	10.756	PK

Note: Measure Level (dBuV/m) = Reading Level (dBuV) + Factor (dB)

Factor (dB) = Cable Loss (dB) + Antenna Factor (dB/m) - Pre_Amplifier Gain (dB)



Site: AC102	Time: 2016/08/01 - 19:18
Limit: FCC_Part15.209_RE(3m)	Margin: 0
Probe:BBHA9120D(1-18GHz)	Polarity: Horizontal
EUT: 1080P Pan/Tilt Wireless IP Camera;720P Pan/Tilt Wireless IP Camera	Power: AC 120V/60Hz
Note: Mode 4: Transmit at channel 2422MHz by 802.11n40	

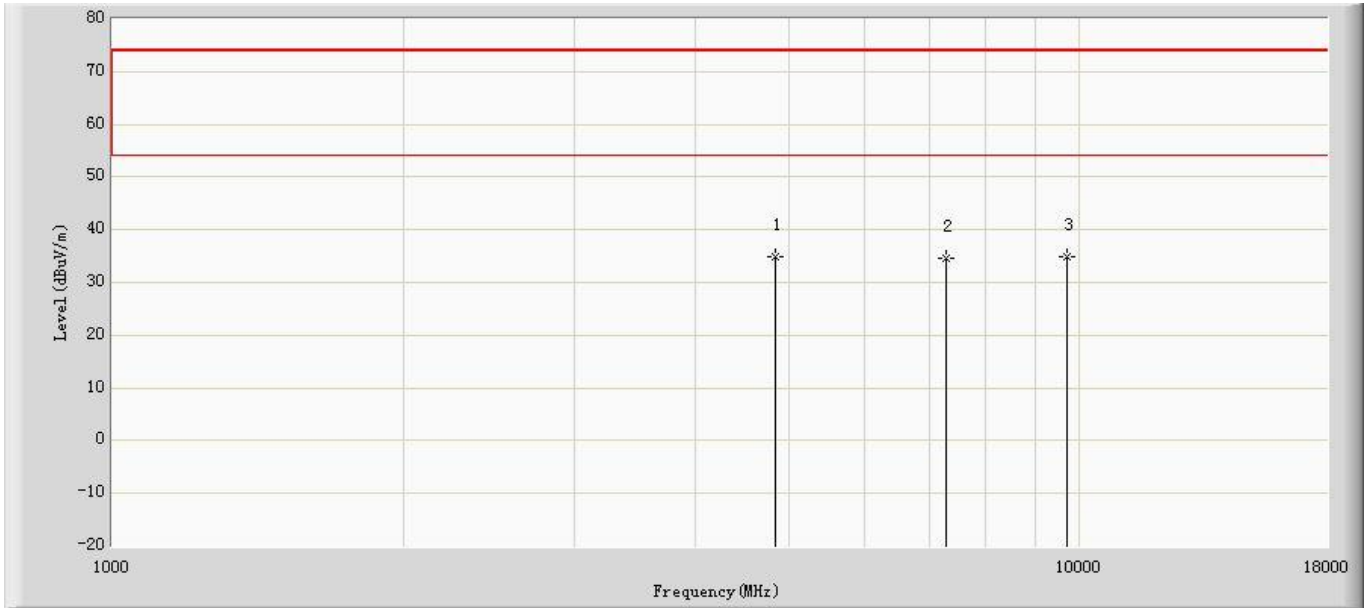

No	Mark	Frequency (MHz)	Measure Level (dBuV/m)	Reading Level (dBuV)	Over Limit (dB)	Limit (dBuV/m)	Factor (dB)	Type
1	*	4844.000	34.913	28.143	-39.087	74.000	6.770	PK
2		7266.000	34.498	25.484	-39.502	74.000	9.014	PK
3		9688.000	34.858	24.311	-39.142	74.000	10.547	PK

Note: Measure Level (dBuV/m) = Reading Level (dBuV) + Factor (dB)

Factor (dB) = Cable Loss (dB) + Antenna Factor (dB/m) - Pre_Amplifier Gain (dB)



Site: AC102	Time: 2016/08/01 - 19:18
Limit: FCC_Part15.209_RE(3m)	Margin: 0
Probe:BBHA9120D(1-18GHz)	Polarity: Vertical
EUT: 1080P Pan/Tilt Wireless IP Camera;720P Pan/Tilt Wireless IP Camera	Power: AC 120V/60Hz
Note: Mode 4: Transmit at channel 2422MHz by 802.11n40	

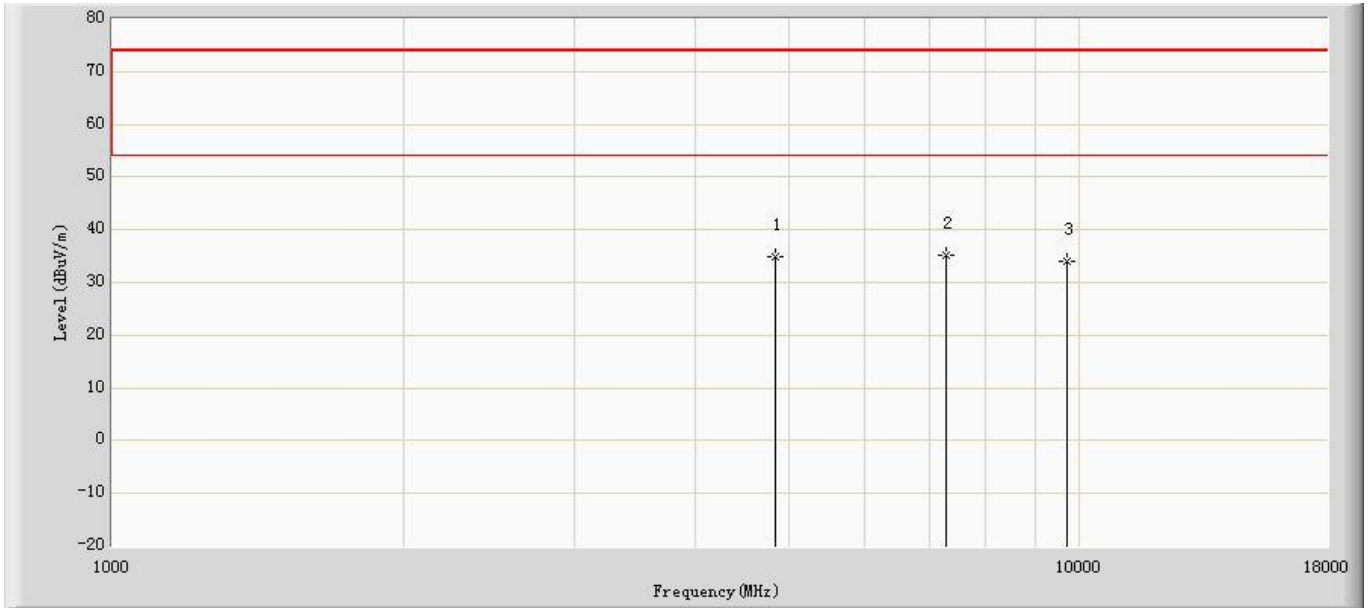

No	Mark	Frequency (MHz)	Measure Level (dBuV/m)	Reading Level (dBuV)	Over Limit (dB)	Limit (dBuV/m)	Factor (dB)	Type
1		4844.000	34.938	28.168	-39.062	74.000	6.770	PK
2	*	7266.000	35.227	26.213	-38.773	74.000	9.014	PK
3		9688.000	33.915	23.368	-40.085	74.000	10.547	PK

Note: Measure Level (dBuV/m) = Reading Level (dBuV) + Factor (dB)

Factor (dB) = Cable Loss (dB) + Antenna Factor (dB/m) - Pre_Amplifier Gain (dB)



Site: AC102	Time: 2016/08/01 - 19:18
Limit: FCC_Part15.209_RE(3m)	Margin: 0
Probe:BBHA9120D(1-18GHz)	Polarity: Horizontal
EUT: 1080P Pan/Tilt Wireless IP Camera;720P Pan/Tilt Wireless IP Camera	Power: AC 120V/60Hz
Note: Mode 4: Transmit at channel 2437MHz by 802.11n40	

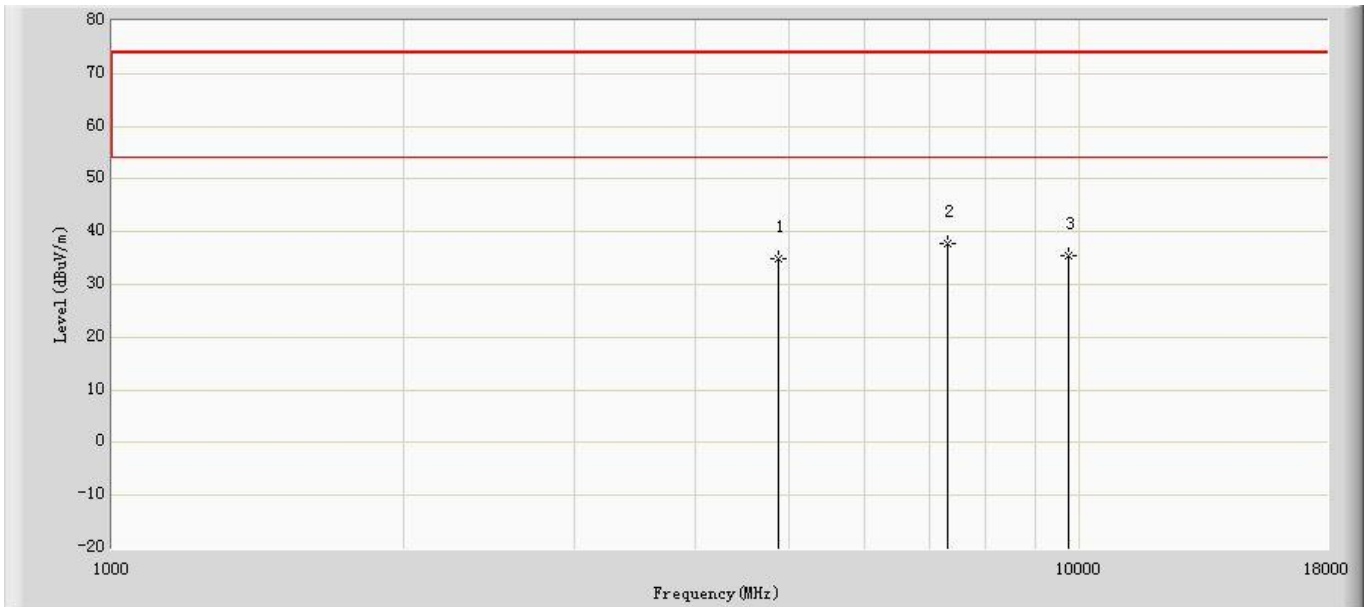

No	Mark	Frequency (MHz)	Measure Level (dBuV/m)	Reading Level (dBuV)	Over Limit (dB)	Limit (dBuV/m)	Factor (dB)	Type
1		4874.000	34.977	28.136	-39.023	74.000	6.841	PK
2	*	7311.000	37.745	28.663	-36.255	74.000	9.082	PK
3		9748.000	35.523	24.911	-38.477	74.000	10.612	PK

Note: Measure Level (dBuV/m) = Reading Level (dBuV) + Factor (dB)

Factor (dB) = Cable Loss (dB) + Antenna Factor (dB/m) - Pre_Amplifier Gain (dB)



Site: AC102	Time: 2016/08/01 - 19:18
Limit: FCC_Part15.209_RE(3m)	Margin: 0
Probe:BBHA9120D(1-18GHz)	Polarity: Vertical
EUT: 1080P Pan/Tilt Wireless IP Camera;720P Pan/Tilt Wireless IP Camera	Power: AC 120V/60Hz
Note: Mode 4: Transmit at channel 2437MHz by 802.11n40	

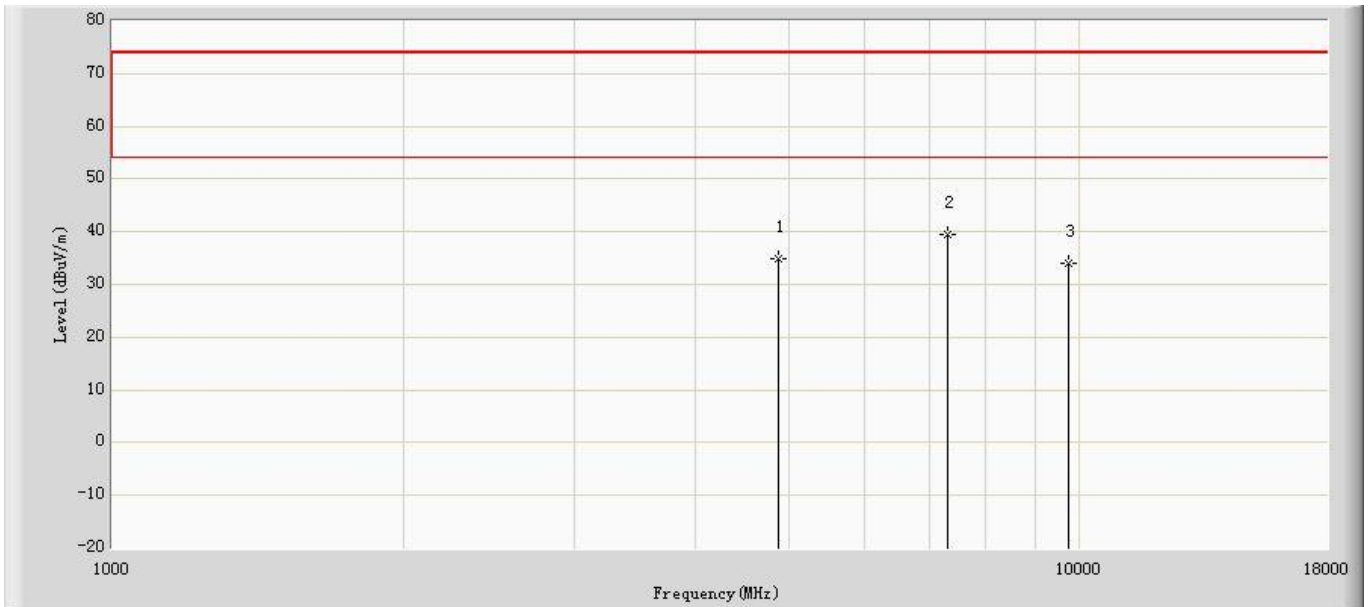

No	Mark	Frequency (MHz)	Measure Level (dBuV/m)	Reading Level (dBuV)	Over Limit (dB)	Limit (dBuV/m)	Factor (dB)	Type
1		4874.000	34.862	28.021	-39.138	74.000	6.841	PK
2	*	7311.000	39.555	30.473	-34.445	74.000	9.082	PK
3		9748.000	33.885	23.273	-40.115	74.000	10.612	PK

Note: Measure Level (dBuV/m) = Reading Level (dBuV) + Factor (dB)

Factor (dB) = Cable Loss (dB) + Antenna Factor (dB/m) - Pre_Amplifier Gain (dB)



Site: AC102	Time: 2016/08/01 - 19:19
Limit: FCC_Part15.209_RE(3m)	Margin: 0
Probe:BBHA9120D(1-18GHz)	Polarity: Horizontal
EUT: 1080P Pan/Tilt Wireless IP Camera;720P Pan/Tilt Wireless IP Camera	Power: AC 120V/60Hz
Note: Mode 4: Transmit at channel 2452MHz by 802.11n40	

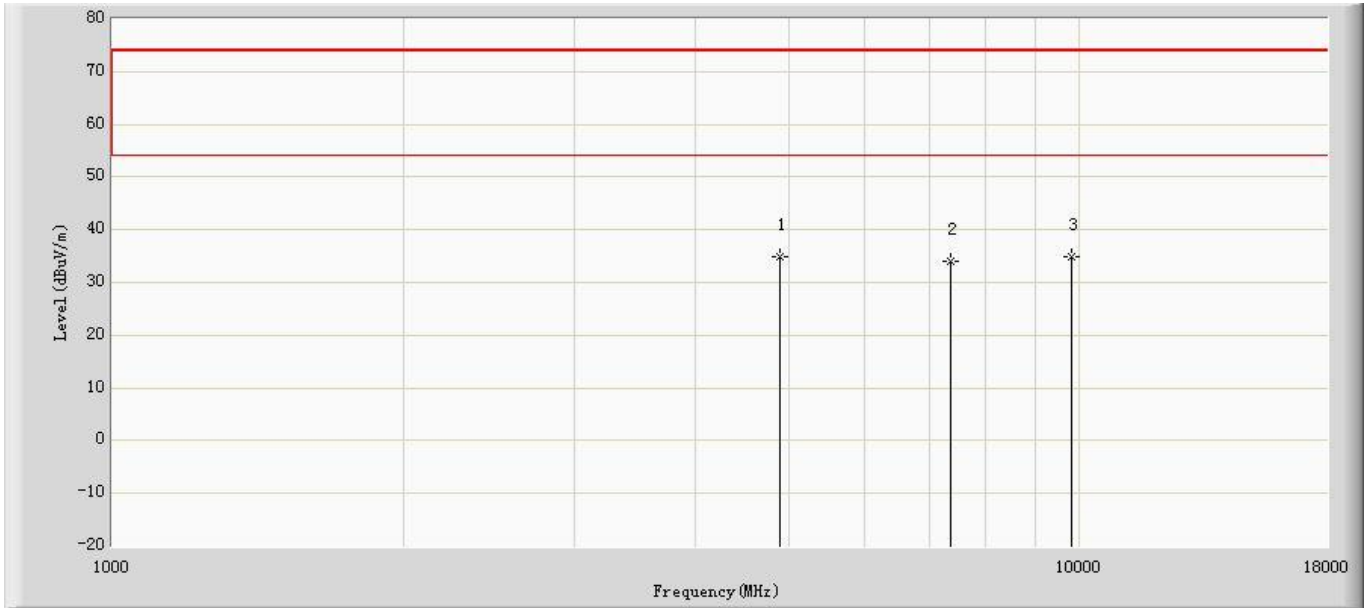

No	Mark	Frequency (MHz)	Measure Level (dBuV/m)	Reading Level (dBuV)	Over Limit (dB)	Limit (dBuV/m)	Factor (dB)	Type
1		4904.000	34.782	27.828	-39.218	74.000	6.954	PK
2		7356.000	34.130	24.998	-39.870	74.000	9.132	PK
3	*	9808.000	34.814	24.104	-39.186	74.000	10.711	PK

Note: Measure Level (dBuV/m) = Reading Level (dBuV) + Factor (dB)

Factor (dB) = Cable Loss (dB) + Antenna Factor (dB/m) - Pre_Amplifier Gain (dB)



Site: AC102	Time: 2016/08/01 - 19:19
Limit: FCC_Part15.209_RE(3m)	Margin: 0
Probe:BBHA9120D(1-18GHz)	Polarity: Vertical
EUT: 1080P Pan/Tilt Wireless IP Camera;720P Pan/Tilt Wireless IP Camera	Power: AC 120V/60Hz
Note: Mode 4: Transmit at channel 2452MHz by 802.11n40	

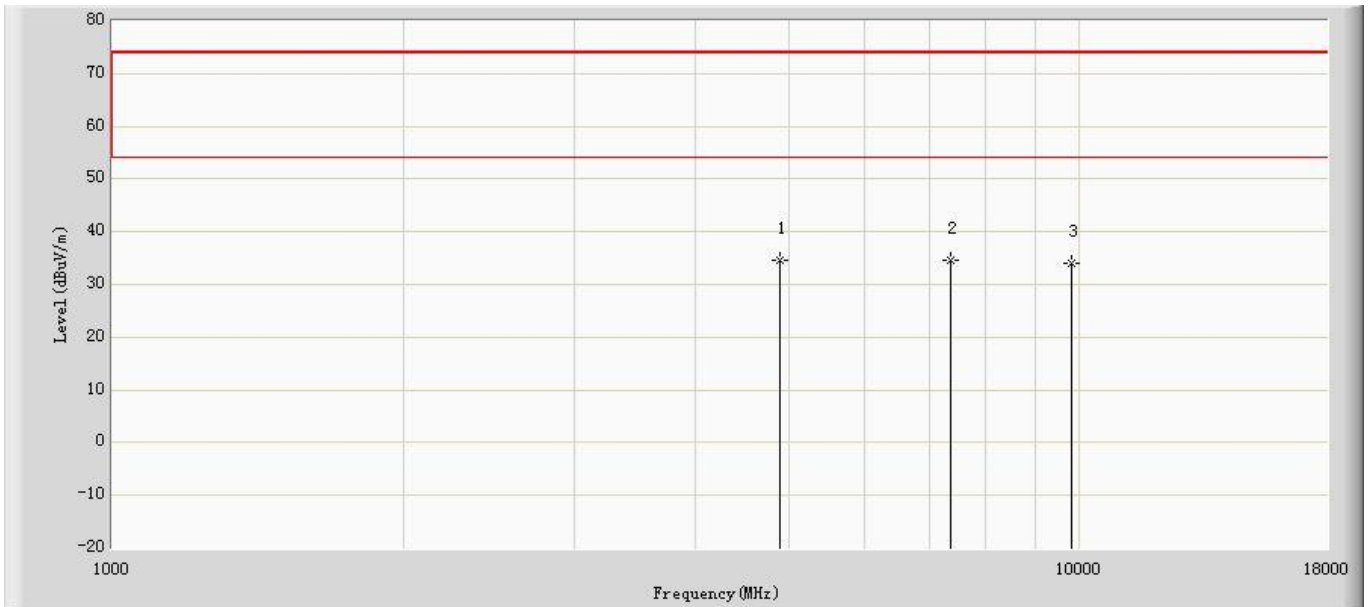

No	Mark	Frequency (MHz)	Measure Level (dBuV/m)	Reading Level (dBuV)	Over Limit (dB)	Limit (dBuV/m)	Factor (dB)	Type
1	*	4904.000	34.706	27.752	-39.294	74.000	6.954	PK
2		7356.000	34.575	25.443	-39.425	74.000	9.132	PK
3		9808.000	33.947	23.237	-40.053	74.000	10.711	PK

Note:

1. Measure Level (dBμV/m) = Reading Level (dBμV) + Factor (dB)
2. Factor (dB) = Cable Loss (dB) + Antenna Factor (dB/m) - Pre_Amplifier Gain (dB)
3. There is the ambient noise within frequency range (9KHz~30MHz,18GHz~40GHz) .
4. The data above is worst case.
5. The average measurement was not performed when the peak measured data under the limit of average detection.
6. The emission levels of other frequencies are very lower than the limit and not show in test report.



6. Maximum Output Power

6.1 Test Limit

The maximum power shall be less 1Watt (30dBm).

The conducted output power limits specified in §15.247(b) are based on the use of transmit antennae with directional gains that do not exceed 6 dBi. If transmit antennae with an effective directional gain greater than 6 dBi are used, then the conducted output power from the EUT shall be reduced as specified in §15.247(b) and (c).

Per RSS247 Issue 1 Section 5.4(4), for DTSs employing digital modulation techniques operating in the bands 902-928 MHz and 2400-2483.5 MHz, the maximum conducted output power shall not exceed 1W.

6.2 Test Procedure

According to KDB558074 D01v03r05 Section 9.1.2- PKPM1 Peak power meter method.

6.3 Test Setup Layout

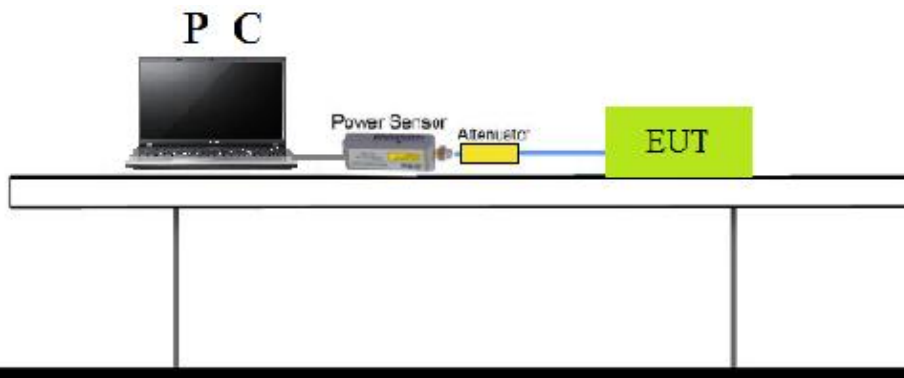

6.4 Measurement Equipment

Instrument	Manufacturer	Type No.	Serial No.	Calibration Date	Valid Date.
PC	Lenovo	E40-70	MP078UQV	N/A	N/A
POWER SENSOR	Agilent	U2021XA	MY53260020	2016/03/27	2017/03/26
Series Power Meter	Boonton	55006	9778	2016/06/08	2017/06/07
Temperature/Humidity Meter	Zhicheng	ZC1-11	CEP-TH-003	2016/03/31	2017/03/30



6.5 Test Result and Data

Power output test was verified over all data rates of each mode shown as below, and then choose the maximum power output (blue marker) for final test of each channel.

MCS Index for 802.11n	Spatial Streams	Data Rate(Mbps)					
		802.11b	802.11g	20MHz Bandwidth		40MHz Bandwidth	
				800ns GI	400ns GI	800ns GI	400ns GI
0	1	1	6	6.5	7.2	13.5	15.0
1	1	2	9	13.0	14.4	27.0	30.0
2	1	5.5	12	19.5	21.7	40.5	45.0
3	1	11	18	26.0	28.9	54.0	60.0
4	1	--	24	39.0	43.3	81.0	90.0
5	1	--	36	52.0	57.8	108.0	120.0
6	1	--	48	58.5	65.0	121.5	135.0
7	1	--	54	65.0	72.2	135.0	150.0
8	2	--	--	13.0	14.4	27.0	30.0
9	2	--	--	26.0	28.9	54.0	60.0
10	2	--	--	39.0	43.3	81.0	90.0
11	2	--	--	52.0	57.8	108.0	120.0
12	2	--	--	78.0	86.7	162.0	180.0
13	2	--	--	104.0	115.6	216.0	240.0
14	2	--	--	117.0	130.0	243.0	270.0
15	2	--	--	130.0	144.0	270.0	300.0



Test Item	Maximum Output Power
Test Mode	Transmit by 802.11b
Test Date	2016-08-02

Channel No.	Frequency (MHz)	Peak Power (dBm)	Required Limit (dBm)	Result
01	2412	21.74	30	Pass
06	2437	21.69	30	Pass
11	2462	21.11	30	Pass

Test Item	Maximum Output Power
Test Mode	Transmit by 802.11g
Test Date	2016-08-02

Channel No.	Frequency (MHz)	Peak Power (dBm)	Required Limit (dBm)	Result
01	2412	22.25	30	Pass
06	2437	21.93	30	Pass
11	2462	21.32	30	Pass

Test Item	Maximum Output Power
Test Mode	Transmit by 802.11n (20MHz)
Test Date	2016-08-02

Channel No.	Frequency (MHz)	Peak Power (dBm)	Required Limit (dBm)	Result
01	2412	21.57	30	Pass
06	2437	21.82	30	Pass
11	2462	20.71	30	Pass



Test Item	Maximum Output Power
Test Mode	Transmit by 802.11n (40MHz)
Test Date	2016-08-02

Channel No.	Frequency (MHz)	Peak Power (dBm)	Required Limit (dBm)	Result
03	2422	21.73	30	Pass
06	2437	21.92	30	Pass
09	2452	20.67	30	Pass



7. Occupied Bandwidth

7.1 Test Limit

Systems using digital modulation techniques may operate in the 902 - 928 MHz, 2400 - 2483.5 MHz, and 5725- 5850 MHz band. The minimum 6 dB bandwidth shall be at least 500 kHz.

7.2 Test Procedures

According to KDB 558074 D01v03r05 - Section 8.1.

- a. The transmitter output was connected to the spectrum analyzer.
- b. Set RBW of spectrum analyzer to 100KHz and $VBW \geq 3x RBW$.
- c. The 6 dB bandwidth is defined as the total spectrum the power of which is higher than peak power minus 6 dB.
- d. The 6dB Bandwidth was measured and recorded.

7.3 Test Setup Layout

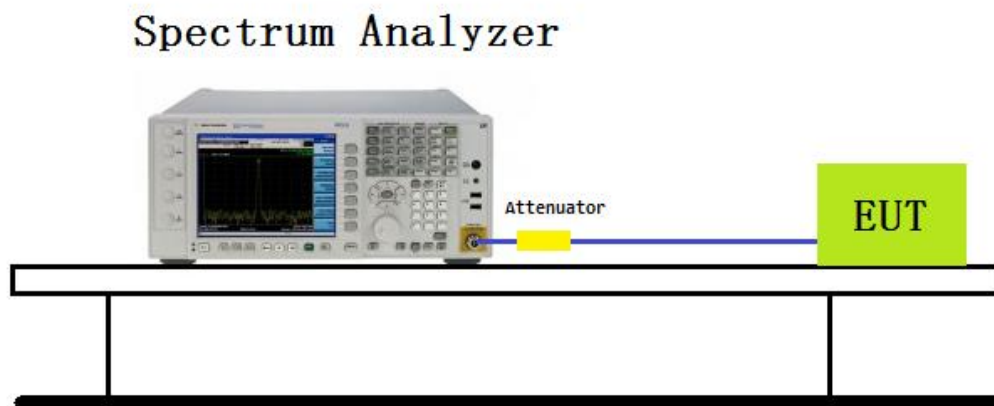

7.4 Measurement Equipment

Instrument/Ancillary	Model No.	Manufacturer	Serial No.	Calibration Date	Valid Date
Spectrum Analyzer	E4407B	Agilent	MY44211883	2015.10.15	2016.10.14



7.5 Test Result and Data

Test Item	Occupied Bandwidth
Test Mode	Transmit by 802.11b
Test Date	2016-08-02

Channel No.	Frequency (MHz)	6dB Measurement Level (MHz)	99% Occupied Bandwidth (MHz)	Result
01	2412	10.14	16.56	Pass
06	2437	10.14	17.08	Pass
11	2462	10.12	16.66	Pass

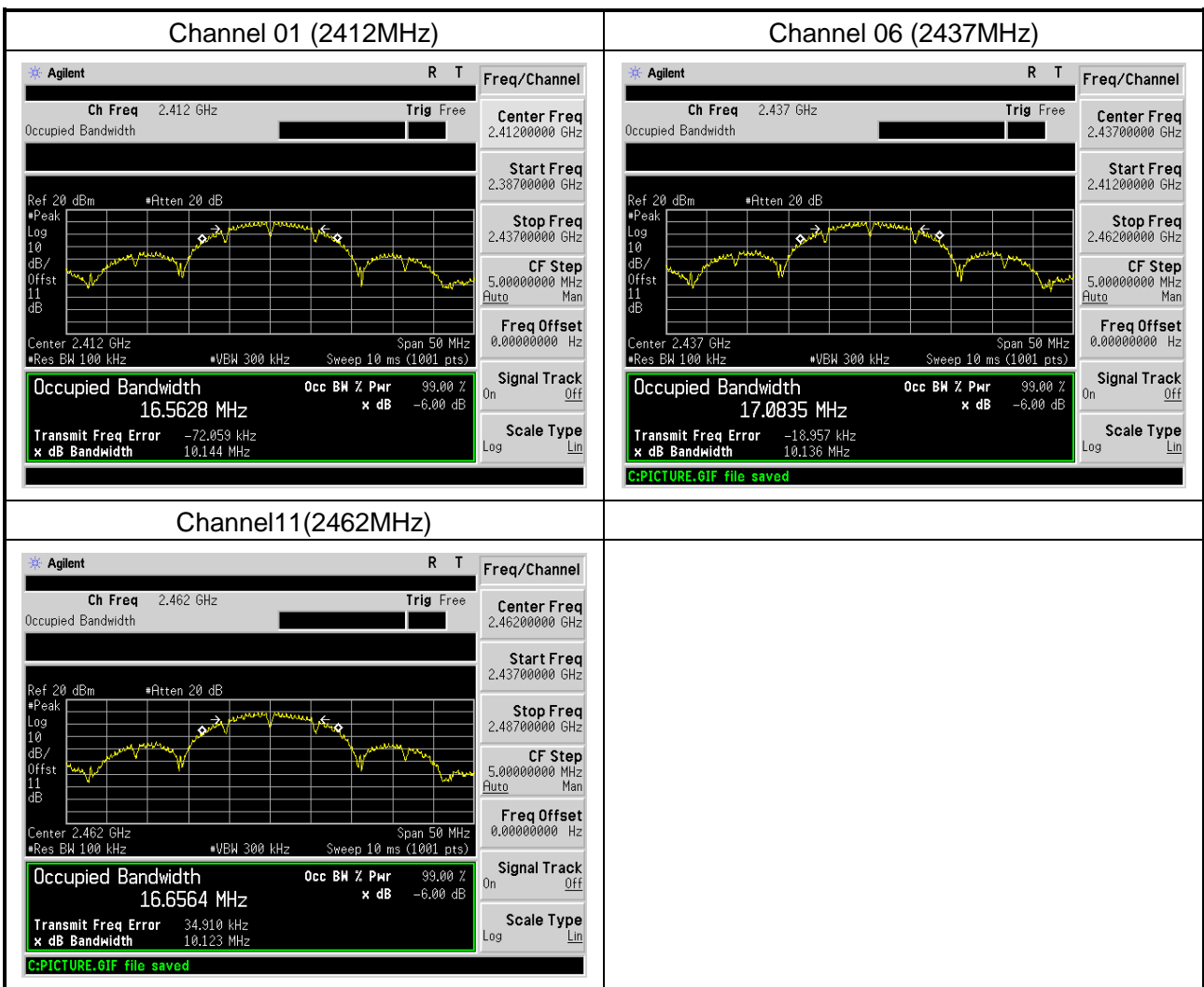



Test Item	Occupied Bandwidth
Test Mode	Transmit by 802.11g
Test Date	2016-08-02

Channel No.	Frequency (MHz)	6dB Measurement Level(MHz)	99% Occupied Bandwidth (MHz)	Result
01	2412	16.53	18.59	Pass
06	2437	16.50	19.70	Pass
11	2462	16.54	16.98	Pass

Channel 01 (2412MHz)

Channel 06 (2437MHz)

Channel 11 (2462MHz)



Test Item	Occupied Bandwidth
Test Mode	Transmit by 802.11n (20MHz)
Test Date	2016-08-02

Channel No.	Frequency (MHz)	6dB Measurement Level(MHz)	99% Occupied Bandwidth (MHz)	Result
01	2412	17.84	17.86	Pass
06	2437	17.80	19.98	Pass
11	2462	17.77	17.84	Pass

Channel 01 (2412MHz)

Channel 01 (2412MHz) Summary:
 Center Freq: 2.412 GHz
 Occupied Bandwidth: 17.8629 MHz
 Transmit Freq Error: -17.385 kHz
 x dB Bandwidth: 17.841 MHz

Channel 06 (2437MHz)

Channel 06 (2437MHz) Summary:
 Center Freq: 2.437 GHz
 Occupied Bandwidth: 19.9804 MHz
 Transmit Freq Error: -554.592 kHz
 x dB Bandwidth: 17.800 MHz

Channel 11 (2462MHz)

Channel 11 (2462MHz) Summary:
 Center Freq: 2.462 GHz
 Occupied Bandwidth: 17.8391 MHz
 Transmit Freq Error: -10.420 kHz
 x dB Bandwidth: 17.769 MHz



Test Item	Occupied Bandwidth
Test Mode	Transmit by 802.11n (40MHz)
Test Date	2016-08-02

Channel No.	Frequency (MHz)	6dB Measurement Level(MHz)	99% Occupied Bandwidth (kHz)	Result
03	2422	36.39	36.06	Pass
06	2437	36.28	36.86	Pass
09	2452	36.33	35.96	Pass

Channel 03 (2422MHz)

Occupied Bandwidth 36.0571 MHz

Transmit Freq Error -9.536 kHz

x dB Bandwidth 36.387 MHz

Channel 06 (2437MHz)

Occupied Bandwidth 36.8646 MHz

Transmit Freq Error -248.048 kHz

x dB Bandwidth 36.280 MHz

Channel 09 (2452MHz)

Occupied Bandwidth 35.9560 MHz

Transmit Freq Error 14.664 kHz

x dB Bandwidth 36.329 MHz



8. Power Spectral Density

8.1 Test Limit

The Maximum of Power Spectral Density Measurement is 8dBm.

8.2 Test Procedure

The EUT was setup according to ANSI C63.10, 2013; tested according to DTS test procedure of KDB 558074 for compliance to FCC 47CFR 15.247 requirements.

The maximum power spectral density using KDB 558074 section 10.2 PKPSD (peak PSD) method.

- a) Set analyzer center frequency to DTS channel center frequency.
- b) Set the span to 1.5 times the DTS bandwidth.
- c) Set the RBW to: $3\text{ kHz} \leq \text{RBW} \leq 100\text{ kHz}$. (Actually we use 3kHz RBW)
- d) Set the VBW $\geq 3 \times \text{RBW}$.
- e) Detector = peak.
- f) Sweep time = auto couple.
- g) Trace mode = max hold.
- h) Allow trace to fully stabilize.
- i) Use the peak marker function to determine the maximum amplitude level within the band.
- j) If measured value exceeds limit, reduce RBW (no less than 3 kHz) and repeat.

8.3 Test Setup Layout

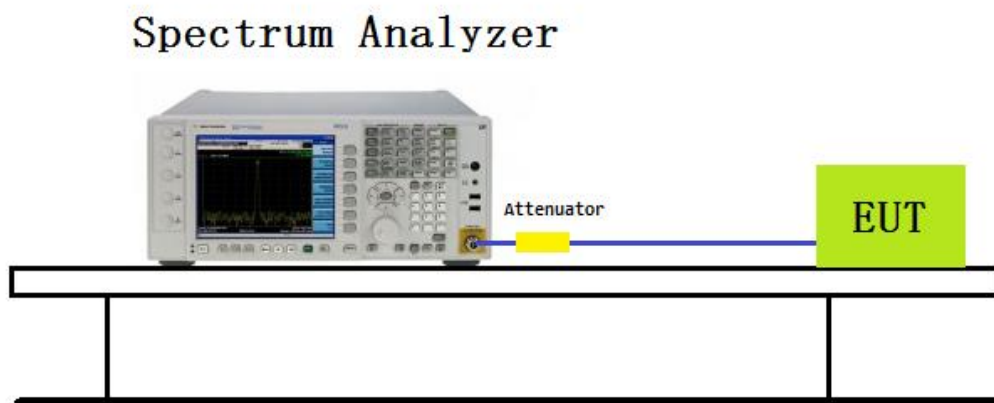

8.4 Measurement Equipment

Instrument/Ancillary	Model No.	Manufacturer	Serial No.	Calibration Date	Valid Date
Spectrum Analyzer	E4407B	Agilent	MY44211883	2015.10.15	2016.10.14



8.5 Test Result and Data

Test Item	Power Spectral Density
Test Mode	Transmit by 802.11b
Test Date	2016-08-02

Channel	Frequency (MHz)	Power Spectral Density (dBm/3kHz)	Limit (dBm/3kHz)	Result
01	2412	-8.707	8	Pass
06	2437	-8.631	8	Pass
11	2462	-9.451	8	Pass

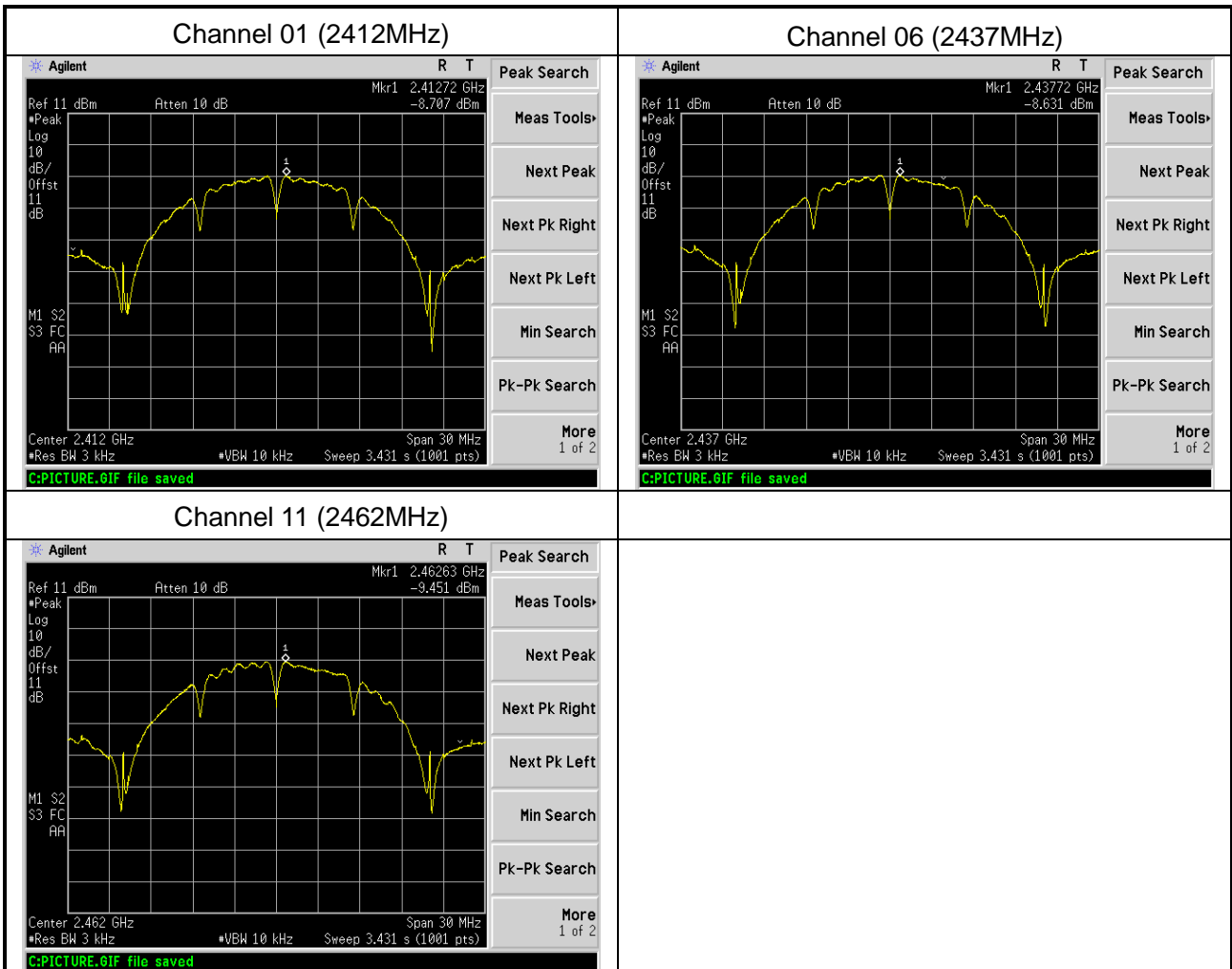



Test Item	Power Spectral Density
Test Mode	Transmit by 802.11g
Test Date	2016-08-02

Channel	Frequency (MHz)	Power Spectral Density (dBm/3kHz)	Limit (dBm/3kHz)	Result
01	2412	-10.21	8	Pass
06	2437	-10.25	8	Pass
11	2462	-11.85	8	Pass

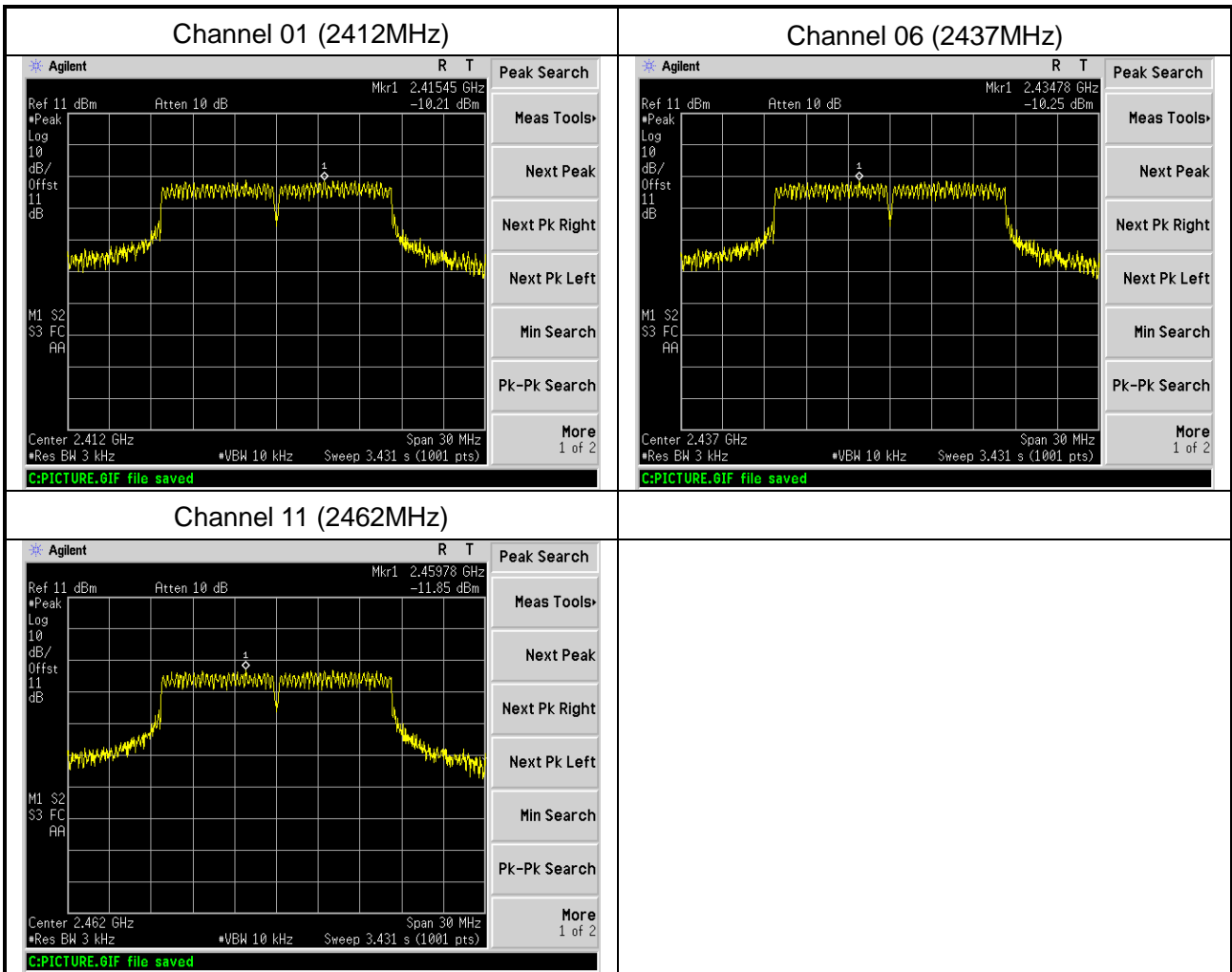



Test Item	Power Spectral Density
Test Mode	Transmit by 802.11n (20MHz)
Test Date	2016-08-02

Channel	Frequency (MHz)	Power Spectral Density (dBm/3kHz)	Limit (dBm/3kHz)	Result
01	2412	-12.05	8	Pass
06	2437	-10.30	8	Pass
11	2462	-13.04	8	Pass

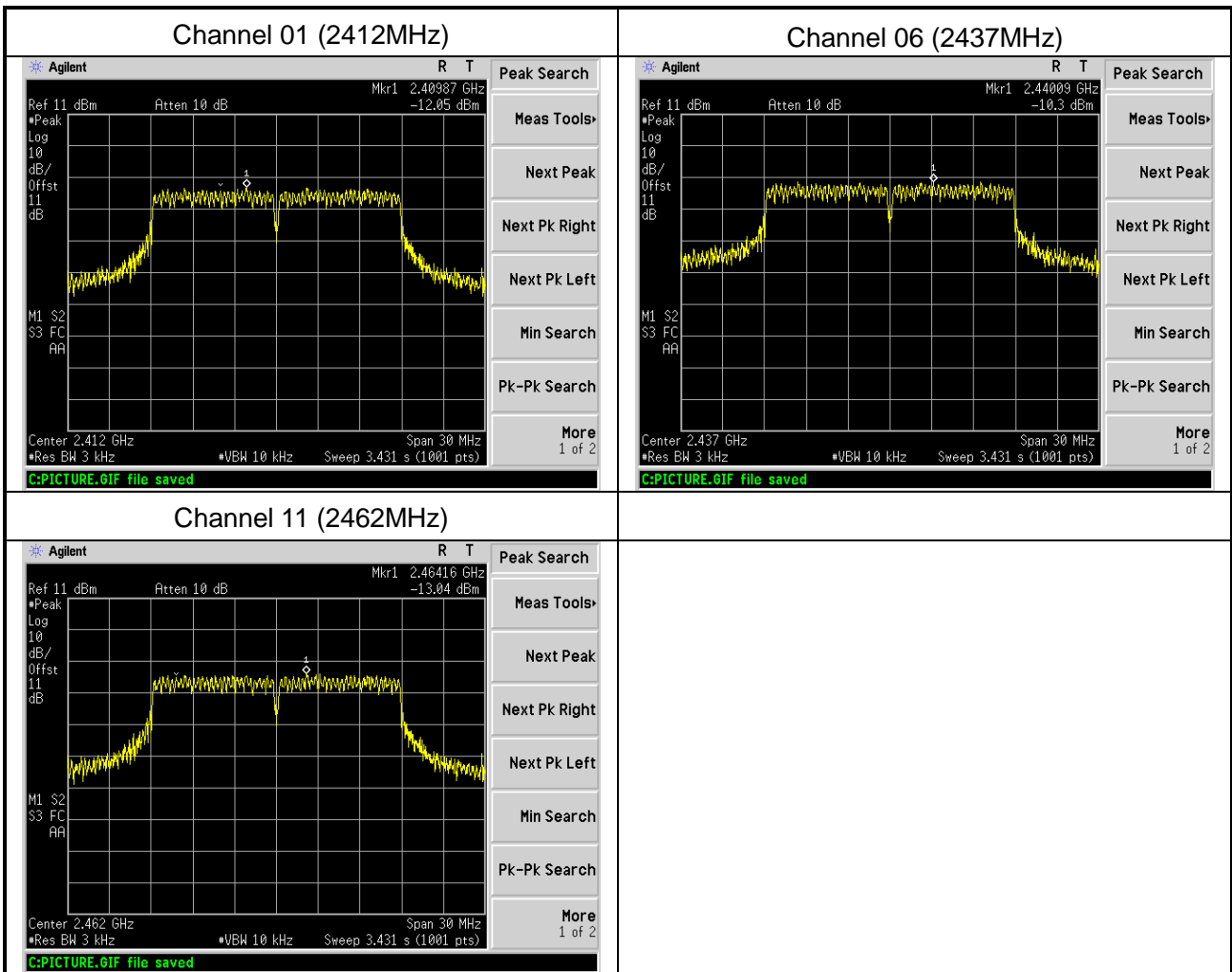



Test Item	Power Spectral Density
Test Mode	Transmit by 802.11n (40MHz)
Test Date	2016-08-02

Channel	Frequency (MHz)	Power Spectral Density (dBm/3kHz)	Limit (dBm/3kHz)	Result
03	2422	-14.34	8	Pass
06	2437	-10.05	8	Pass
09	2452	-14.12	8	Pass

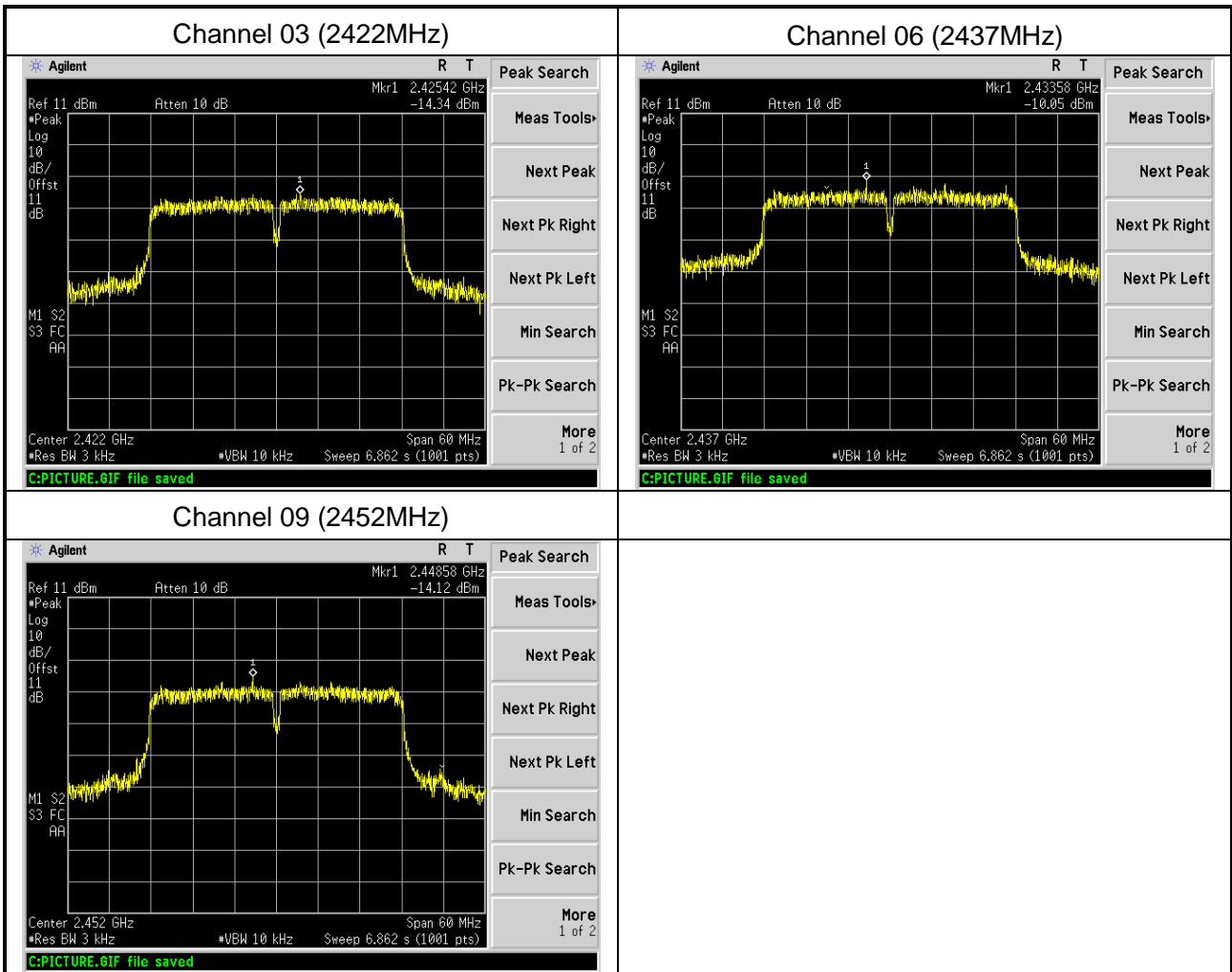



9. Band Edges Measurement

9.1 Test Limit

1. If the maximum peak conducted output power procedure was used to determine compliance as described in 11.9.1, then the peak output power measured in any 100 kHz bandwidth outside of the authorized frequency band shall be attenuated by at least 20 dB relative to the maximum.
2. If maximum conducted (average) output power was used to determine compliance as described in 11.9.2, then the peak power in any 100 kHz bandwidth outside of the authorized frequency band shall be attenuated by at least 30 dB relative to the maximum in-band peak PSD level in 100 kHz (i.e., 30 dBc).



9.2 Test Procedure

KDB 558074 D01v03r05 – Section 12.2.4 (peak power measurements)

KDB 558074 D01v03r05 – Section 12.2.5 (average power measurements)

9.3 Test Setting

Peak Measurements above 1GHz

1. Analyzer center frequency was set to the frequency of the radiated spurious emission of interest
2. RBW = 1MHz
3. VBW = 3MHz
4. Detector = peak
5. Sweep time = auto couple
6. Trace mode = max hold
7. Trace was allowed to stabilize

Average Measurements above 1GHz

1. Analyzer center frequency was set to the frequency of the radiated spurious emission of interest

2. RBW = 1MHz

3. VBW \geq 1/T

Note: For b mode VBW=10Hz; For g mode VBW=10Hz; For n(20MHz) mode VBW=10Hz; For n(40MHz) mode VBW=10Hz.

4. As an alternative, the instrument may be set to linear detector mode. Ensure that video filtering is applied in linear voltage domain (rather than in a log or dB domain). Some instruments require linear display mode in order to accomplish this. Others have a setting for Average-VBW Type, which can be set to "Voltage" regardless of the display mode

5. Detector = Peak

6. Sweep time = auto

7. Trace mode = max hold

8. Allow max hold to run for at least 50 times (1/duty cycle) traces



9.4 Test Setup Layout

Radiated

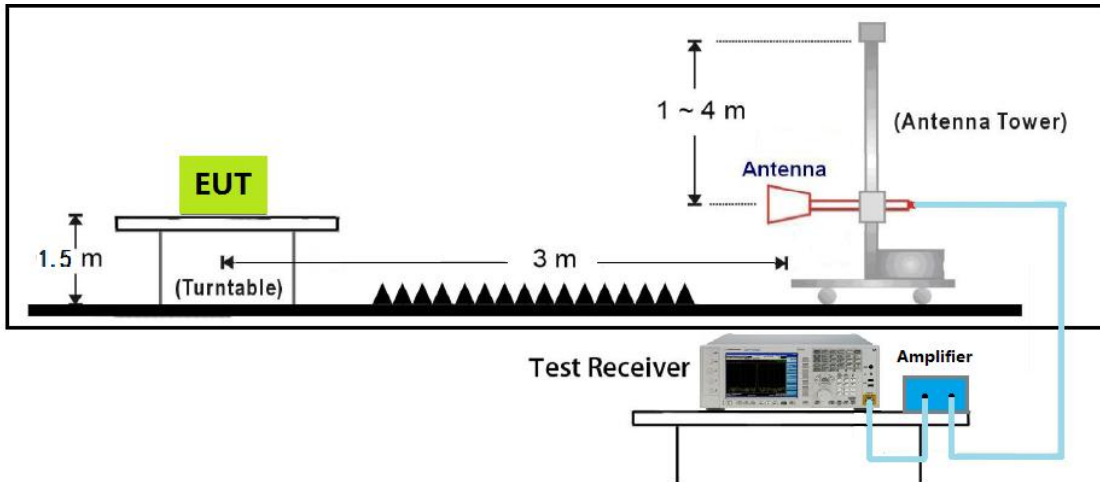

Conducted

Spectrum Analyzer

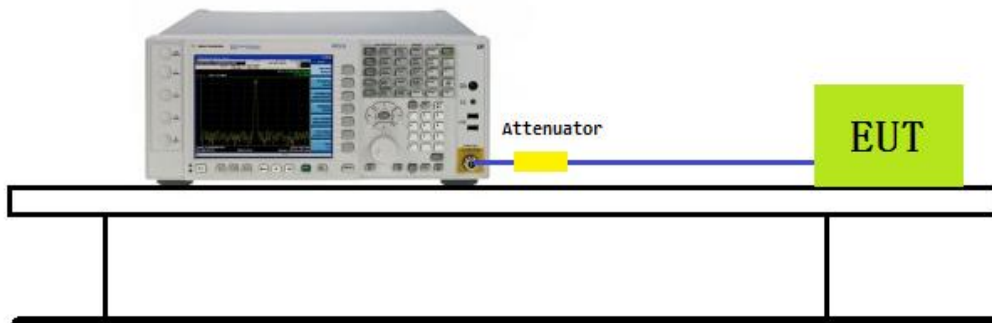

**9.5 Measurement Equipment**

Instrument/Ancillary	Manufacturer	Model No.	Serial No.	Calibration Date	Valid Date.
EMI Test Receiver	R&S	ESCI	101183	2016.03.28	2017.03.29
Spectrum Analyzer	N9010A	Agilent	MY53400169	2015.11.11	2016.11.11
Spectrum Analyzer	E4407B	Agilent	MY44211883	2015.10.15	2016.10.14
Spectrum Analyzer	R&S	FSP40	100324	2016.03.23	2017.03.24
H64 Preamplifier	HP	8447F	3113A05582	2016.03.24	2017.03.23
Preamplifier	songyi	EM330	60618	2016.03.29	2017.03.28
Preamplifier	Agilent	8449B	3008A02342	2016.03.29	2017.03.28
Preamplifier	COM-POWER	PA-840	711885	2016.03.29	2017.03.28
Bilog Antenna	Sunol Science	JB1	A072414-1	2016.04.22	2017.04.21
Broad-Band Horn Antenna	Schwarzbeck	BBHA9120D	9120D-619	2016.04.20	2017.04.19
Broad-Band Horn Antenna	Schwarzbeck	BBHA9170	9170-347	2016.04.20	2017.04.19
Temperature/ Humidity Meter	Zhicheng	ZC1-11	CEP-TH-002	2016.03.31	2017.03.30



9.6 Test Result and Data

Radiated

Engineer: Kerry	
Site: AC102	Time: 2016/08/04 - 13:13
Limit: FCC_Part15.209_RE(3m)	Margin: 0
Probe: BBHA9120D(1-18GHz)	Polarity: Horizontal
EUT: 1080P Pan/Tilt Wireless IP Camera;720P Pan/Tilt Wireless IP Camera	Power: AC 120V/60Hz
Note: Mode:Transmit 802.11b at 2412MHz	



No	Mark	Frequency (MHz)	Measure Level (dBuV/m)	Reading Level (dBuV)	Over Limit (dB)	Limit (dBuV/m)	Factor (dB)	Type
1		2390.000	62.249	72.688	-11.751	74.000	-10.439	PK
2	*	2418.416	110.056	120.368	N/A	N/A	-10.312	PK

Note: Measure Level (dBμV/m) = Reading Level (dBμV) + Factor (dB)

Factor (dB) = Cable Loss (dB) + Antenna Factor (dB/m) - Pre_Amplifier Gain (dB)



Engineer: Kerry	
Site: AC102	Time: 2016/08/04 - 13:25
Limit: FCC_Part15.209_RE(3m)	Margin: 0
Probe: BBHA9120D(1-18GHz)	Polarity: Horizontal
EUT: 1080P Pan/Tilt Wireless IP Camera;720P Pan/Tilt Wireless IP Camera	Power: AC 120V/60Hz
Note: Mode:Transmit 802.11b at 2412MHz	

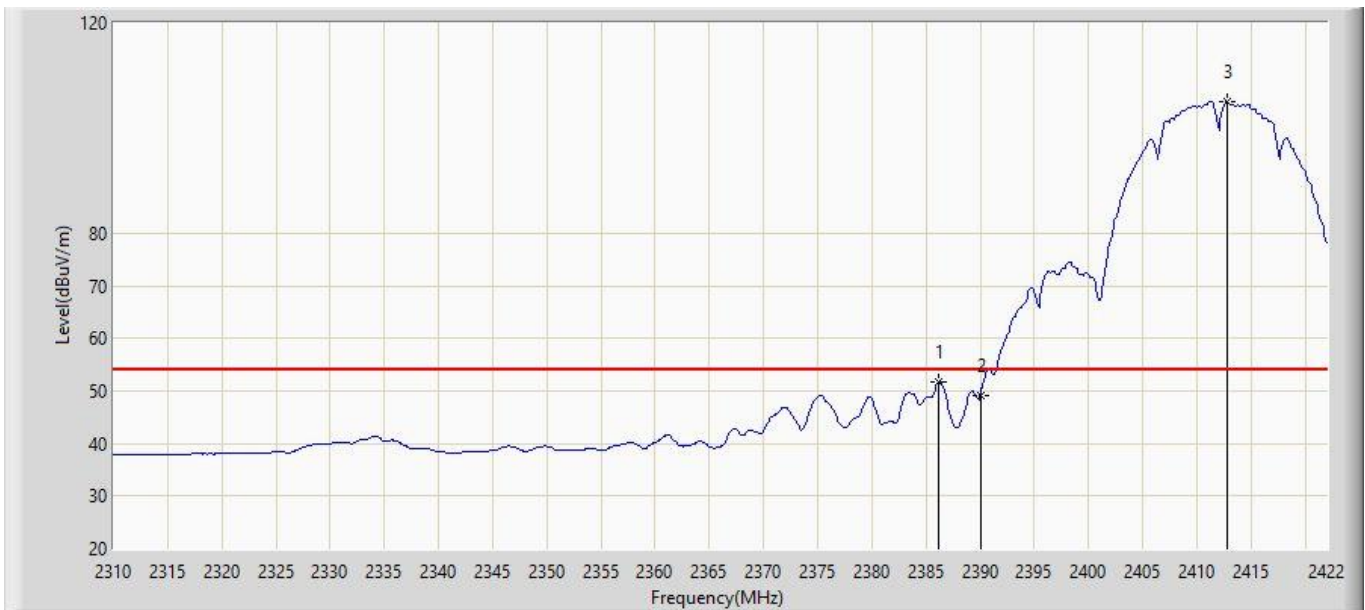

No	Mark	Frequency (MHz)	Measure Level (dBuV/m)	Reading Level (dBuV)	Over Limit (dB)	Limit (dBuV/m)	Factor (dB)	Type
1		2386.160	51.613	62.069	-2.387	54.000	-10.456	AV
2		2390.000	49.126	59.565	-4.874	54.000	-10.439	AV
3	*	2412.816	105.010	115.347	N/A	N/A	-10.337	AV

Note: Measure Level (dBμV/m) = Reading Level (dBμV) + Factor (dB)

Factor (dB) = Cable Loss (dB) + Antenna Factor (dB/m) - Pre_Amplifier Gain (dB)



Engineer: Kerry	
Site: AC102	Time: 2016/08/04 - 13:28
Limit: FCC_Part15.209_RE(3m)	Margin: 0
Probe: BBHA9120D(1-18GHz)	Polarity: Vertical
EUT: 1080P Pan/Tilt Wireless IP Camera;720P Pan/Tilt Wireless IP Camera	Power: AC 120V/60Hz
Note: Mode:Transmit 802.11b at 2412MHz	

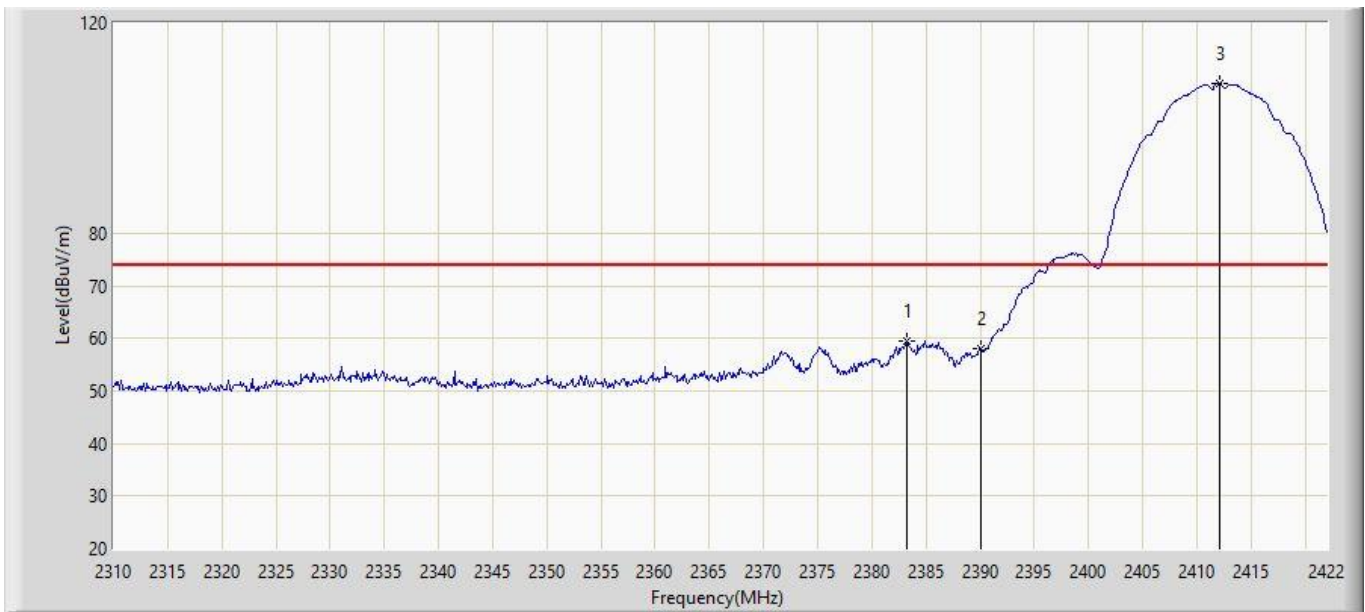

No	Mark	Frequency (MHz)	Measure Level (dBuV/m)	Reading Level (dBuV)	Over Limit (dB)	Limit (dBuV/m)	Factor (dB)	Type
1		2383.248	59.449	69.917	-14.551	74.000	-10.468	PK
2		2390.000	57.903	68.342	-16.097	74.000	-10.439	PK
3	*	2412.144	108.546	118.886	N/A	N/A	-10.340	PK

Note: Measure Level (dBμV/m) = Reading Level (dBμV) + Factor (dB)

Factor (dB) = Cable Loss (dB) + Antenna Factor (dB/m) - Pre_Amplifier Gain (dB)



Engineer: Kerry	
Site: AC102	Time: 2016/08/04 - 13:34
Limit: FCC_Part15.209_RE(3m)	Margin: 0
Probe: BBHA9120D(1-18GHz)	Polarity: Vertical
EUT: 1080P Pan/Tilt Wireless IP Camera;720P Pan/Tilt Wireless IP Camera	Power: AC 120V/60Hz
Note: Mode:Transmit 802.11b at 2412MHz	



No	Mark	Frequency (MHz)	Measure Level (dBuV/m)	Reading Level (dBuV)	Over Limit (dB)	Limit (dBuV/m)	Factor (dB)	Type
1		2383.584	49.407	59.874	-4.593	54.000	-10.467	AV
2		2390.000	46.020	56.459	-7.980	54.000	-10.439	AV
3	*	2411.248	104.657	115.001	N/A	N/A	-10.344	AV

Note: Measure Level (dBμV/m) = Reading Level (dBμV) + Factor (dB)

Factor (dB) = Cable Loss (dB) + Antenna Factor (dB/m) - Pre_Amplifier Gain (dB)



Engineer: Kerry	
Site: AC102	Time: 2016/08/04 - 13:37
Limit: FCC_Part15.209_RE(3m)	Margin: 0
Probe: BBHA9120D(1-18GHz)	Polarity: Horizontal
EUT: 1080P Pan/Tilt Wireless IP Camera;720P Pan/Tilt Wireless IP Camera	Power: AC 120V/60Hz
Note: Mode:Transmit 802.11b at 2462MHz	



No	Mark	Frequency (MHz)	Measure Level (dBuV/m)	Reading Level (dBuV)	Over Limit (dB)	Limit (dBuV/m)	Factor (dB)	Type
1	*	2461.984	110.126	120.245	N/A	N/A	-10.119	PK
2		2483.500	64.231	74.254	-9.769	74.000	-10.023	PK
3		2484.352	64.575	74.594	-9.425	74.000	-10.019	PK

Note: Measure Level (dBuV/m) = Reading Level (dBuV) + Factor (dB)

Factor (dB) = Cable Loss (dB) + Antenna Factor (dB/m) - Pre_Amplifier Gain (dB)



Engineer: Kerry	
Site: AC102	Time: 2016/08/04 - 13:42
Limit: FCC_Part15.209_RE(3m)	Margin: 0
Probe: BBHA9120D(1-18GHz)	Polarity: Horizontal
EUT: 1080P Pan/Tilt Wireless IP Camera;720P Pan/Tilt Wireless IP Camera	Power: AC 120V/60Hz
Note: Mode:Transmit 802.11b at 2462MHz	

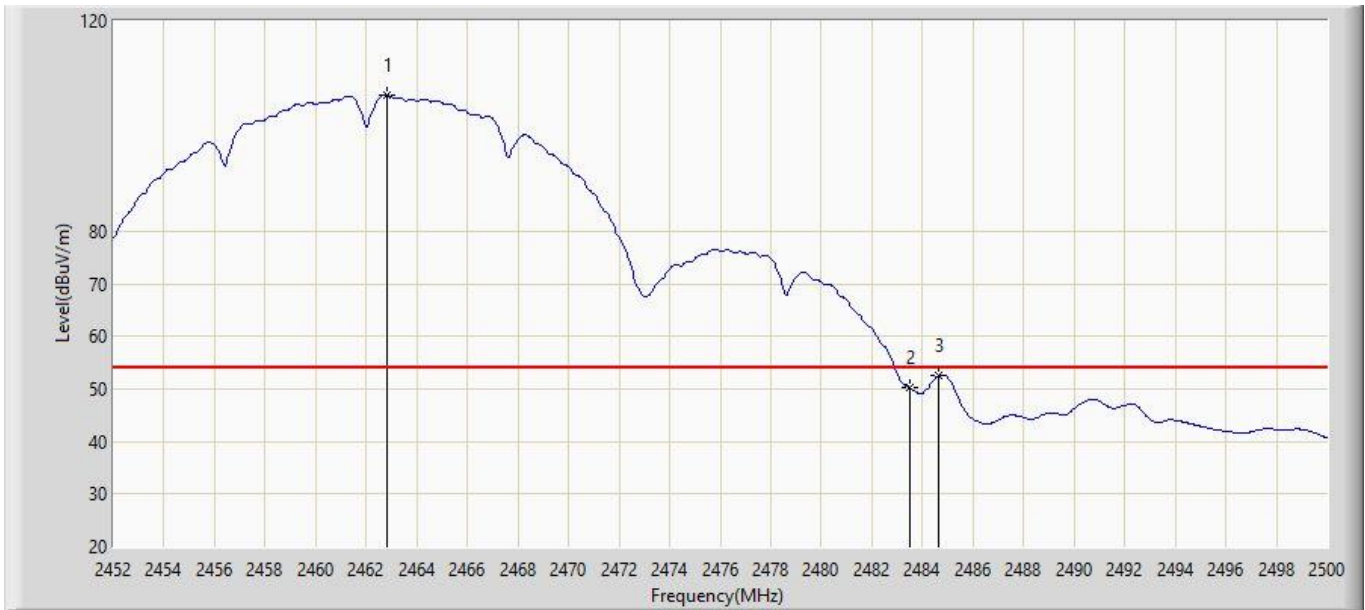

No	Mark	Frequency (MHz)	Measure Level (dBuV/m)	Reading Level (dBuV)	Over Limit (dB)	Limit (dBuV/m)	Factor (dB)	Type
1	*	2462.800	105.984	116.099	N/A	N/A	-10.115	AV
2		2483.500	50.186	60.209	-3.814	54.000	-10.023	AV
3		2484.640	52.514	62.532	-1.486	54.000	-10.018	AV

Note: Measure Level (dBμV/m) = Reading Level (dBμV) + Factor (dB)

Factor (dB) = Cable Loss (dB) + Antenna Factor (dB/m) - Pre_Amplifier Gain (dB)



Engineer: Kerry	
Site: AC102	Time: 2016/08/04 - 13:43
Limit: FCC_Part15.209_RE(3m)	Margin: 0
Probe: BBHA9120D(1-18GHz)	Polarity: Vertical
EUT: 1080P Pan/Tilt Wireless IP Camera;720P Pan/Tilt Wireless IP Camera	Power: AC 120V/60Hz
Note: Mode:Transmit 802.11b at 2462MHz	



No	Mark	Frequency (MHz)	Measure Level (dBuV/m)	Reading Level (dBuV)	Over Limit (dB)	Limit (dBuV/m)	Factor (dB)	Type
1	*	2462.032	108.080	118.199	N/A	N/A	-10.119	PK
2		2483.500	60.369	70.392	-13.631	74.000	-10.023	PK
3		2483.920	61.607	71.628	-12.393	74.000	-10.021	PK

Note: Measure Level (dBuV/m) = Reading Level (dBuV) + Factor (dB)

Factor (dB) = Cable Loss (dB) + Antenna Factor (dB/m) - Pre_Amplifier Gain (dB)



Engineer: Kerry	
Site: AC102	Time: 2016/08/04 - 13:46
Limit: FCC_Part15.209_RE(3m)	Margin: 0
Probe: BBHA9120D(1-18GHz)	Polarity: Vertical
EUT: 1080P Pan/Tilt Wireless IP Camera;720P Pan/Tilt Wireless IP Camera	Power: AC 120V/60Hz
Note: Mode:Transmit 802.11b at 2462MHz	



No	Mark	Frequency (MHz)	Measure Level (dBuV/m)	Reading Level (dBuV)	Over Limit (dB)	Limit (dBuV/m)	Factor (dB)	Type
1	*	2462.608	104.035	114.151	N/A	N/A	-10.116	AV
2		2483.500	49.663	59.686	-4.337	54.000	-10.023	AV
3		2484.736	50.199	60.217	-3.801	54.000	-10.018	AV

Note: Measure Level (dBuV/m) = Reading Level (dBuV) + Factor (dB)

Factor (dB) = Cable Loss (dB) + Antenna Factor (dB/m) - Pre_Amplifier Gain (dB)



Engineer: Kerry	
Site: AC102	Time: 2016/08/04 - 13:47
Limit: FCC_Part15.209_RE(3m)	Margin: 0
Probe: BBHA9120D(1-18GHz)	Polarity: Horizontal
EUT: 1080P Pan/Tilt Wireless IP Camera;720P Pan/Tilt Wireless IP Camera	Power: AC 120V/60Hz
Note: Mode:Transmit 802.11g at 2412MHz	



No	Mark	Frequency (MHz)	Measure Level (dBuV/m)	Reading Level (dBuV)	Over Limit (dB)	Limit (dBuV/m)	Factor (dB)	Type
1		2390.000	72.935	83.374	-1.065	74.000	-10.439	PK
2	*	2418.080	107.743	118.057	N/A	N/A	-10.314	PK

Note: Measure Level (dBuV/m) = Reading Level (dBuV) + Factor (dB)

Factor (dB) = Cable Loss (dB) + Antenna Factor (dB/m) - Pre_Amplifier Gain (dB)



Engineer: Kerry	
Site: AC102	Time: 2016/08/04 - 13:50
Limit: FCC_Part15.209_RE(3m)	Margin: 0
Probe: BBHA9120D(1-18GHz)	Polarity: Horizontal
EUT: 1080P Pan/Tilt Wireless IP Camera;720P Pan/Tilt Wireless IP Camera	Power: AC 120V/60Hz
Note: Mode:Transmit 802.11g at 2412MHz	

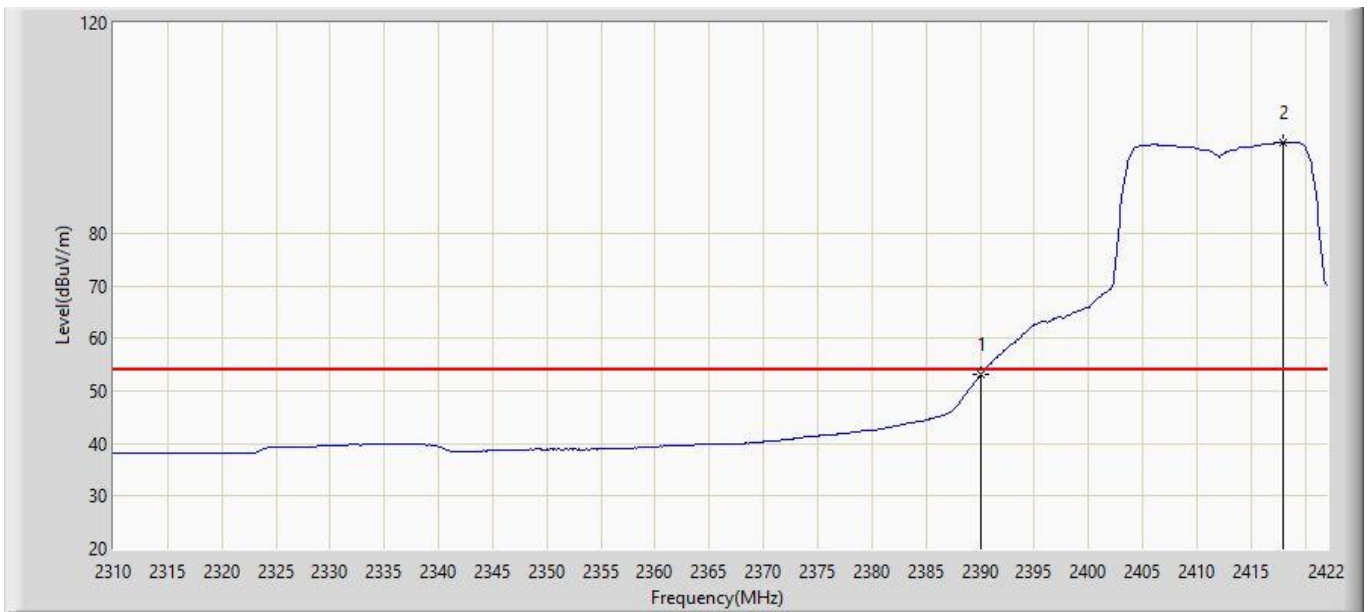

No	Mark	Frequency (MHz)	Measure Level (dBuV/m)	Reading Level (dBuV)	Over Limit (dB)	Limit (dBuV/m)	Factor (dB)	Type
1		2390.000	53.051	63.490	-0.949	54.000	-10.439	AV
2	*	2417.968	97.177	107.491	N/A	N/A	-10.314	AV

Note: Measure Level (dBuV/m) = Reading Level (dBuV) + Factor (dB)

Factor (dB) = Cable Loss (dB) + Antenna Factor (dB/m) - Pre_Amplifier Gain (dB)



Engineer: Kerry	
Site: AC102	Time: 2016/08/04 - 13:50
Limit: FCC_Part15.209_RE(3m)	Margin: 0
Probe: BBHA9120D(1-18GHz)	Polarity: Vertical
EUT: 1080P Pan/Tilt Wireless IP Camera;720P Pan/Tilt Wireless IP Camera	Power: AC 120V/60Hz
Note: Mode:Transmit 802.11g at 2412MHz	

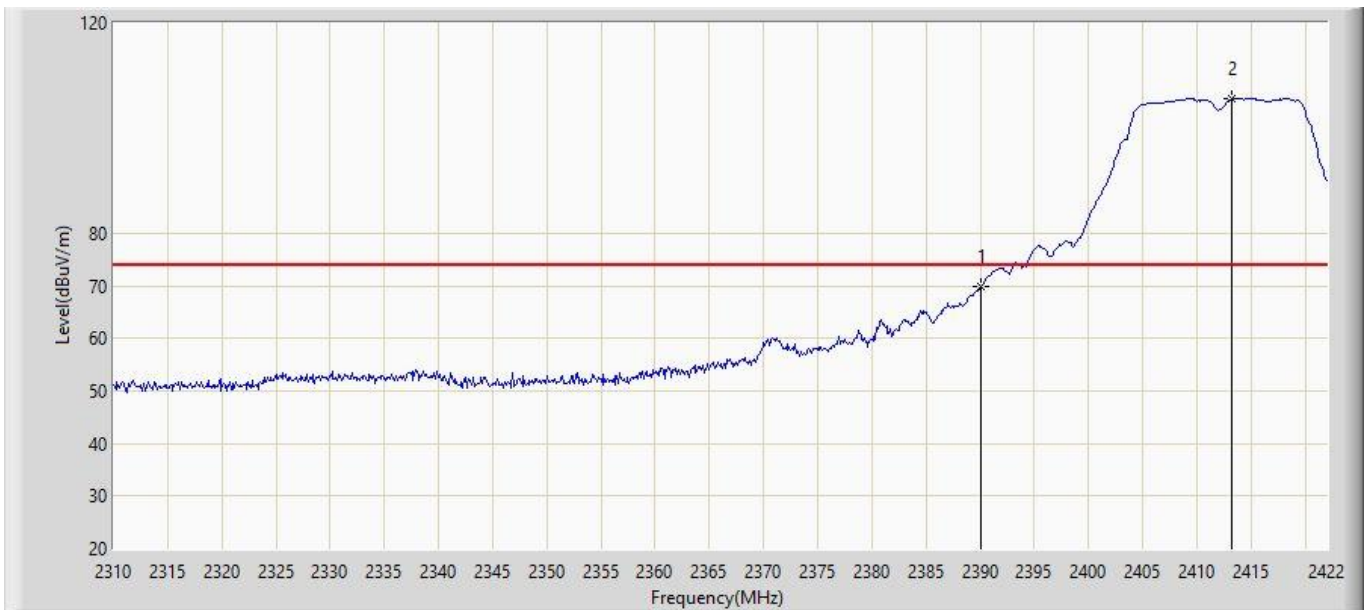

No	Mark	Frequency (MHz)	Measure Level (dBuV/m)	Reading Level (dBuV)	Over Limit (dB)	Limit (dBuV/m)	Factor (dB)	Type
1		2390.000	69.768	80.207	-4.232	74.000	-10.439	PK
2	*	2413.264	105.569	115.904	N/A	N/A	-10.335	PK

Note: Measure Level (dBuV/m) = Reading Level (dBuV) + Factor (dB)

Factor (dB) = Cable Loss (dB) + Antenna Factor (dB/m) - Pre_Amplifier Gain (dB)



Engineer: Kerry	
Site: AC102	Time: 2016/08/04 - 13:51
Limit: FCC_Part15.209_RE(3m)	Margin: 0
Probe: BBHA9120D(1-18GHz)	Polarity: Vertical
EUT: 1080P Pan/Tilt Wireless IP Camera;720P Pan/Tilt Wireless IP Camera	Power: AC 120V/60Hz
Note: Mode:Transmit 802.11g at 2412MHz	

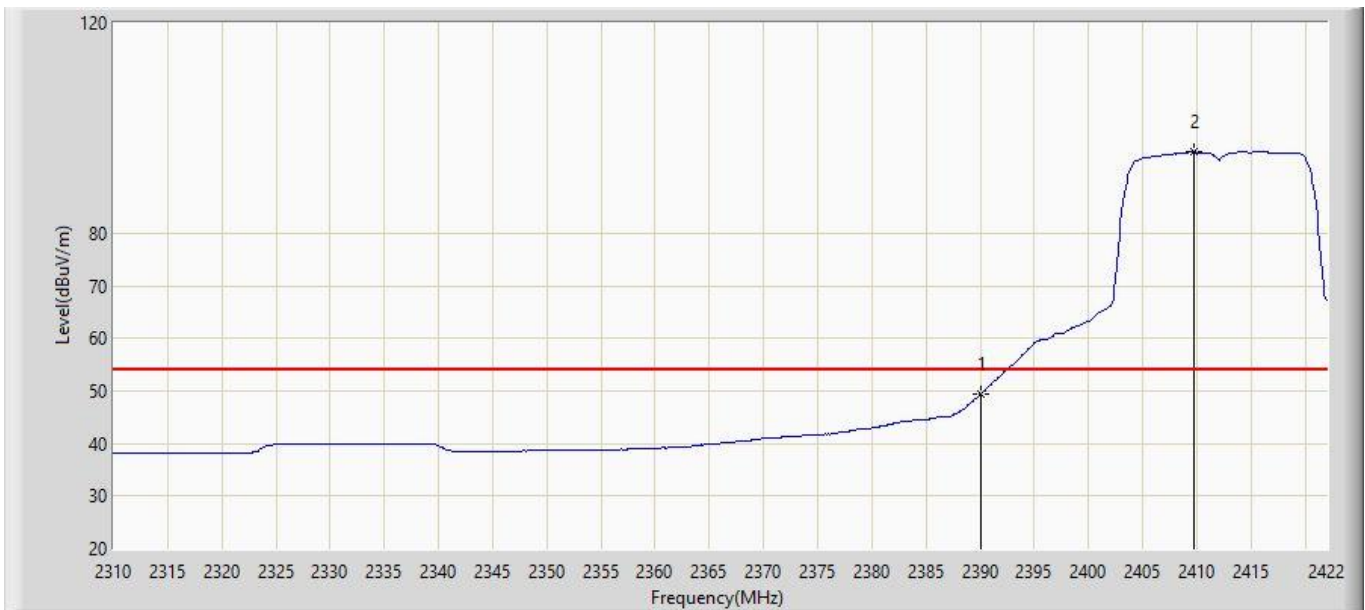

No	Mark	Frequency (MHz)	Measure Level (dBuV/m)	Reading Level (dBuV)	Over Limit (dB)	Limit (dBuV/m)	Factor (dB)	Type
1		2390.000	49.350	59.789	-4.650	54.000	-10.439	AV
2	*	2409.680	95.479	105.830	N/A	N/A	-10.351	AV

Note: Measure Level (dBuV/m) = Reading Level (dBuV) + Factor (dB)

Factor (dB) = Cable Loss (dB) + Antenna Factor (dB/m) - Pre_Amplifier Gain (dB)



Engineer: Kerry	
Site: AC102	Time: 2016/08/04 - 13:52
Limit: FCC_Part15.209_RE(3m)	Margin: 0
Probe: BBHA9120D(1-18GHz)	Polarity: Horizontal
EUT: 1080P Pan/Tilt Wireless IP Camera;720P Pan/Tilt Wireless IP Camera	Power: AC 120V/60Hz
Note: Mode:Transmit 802.11g at 2462MHz	

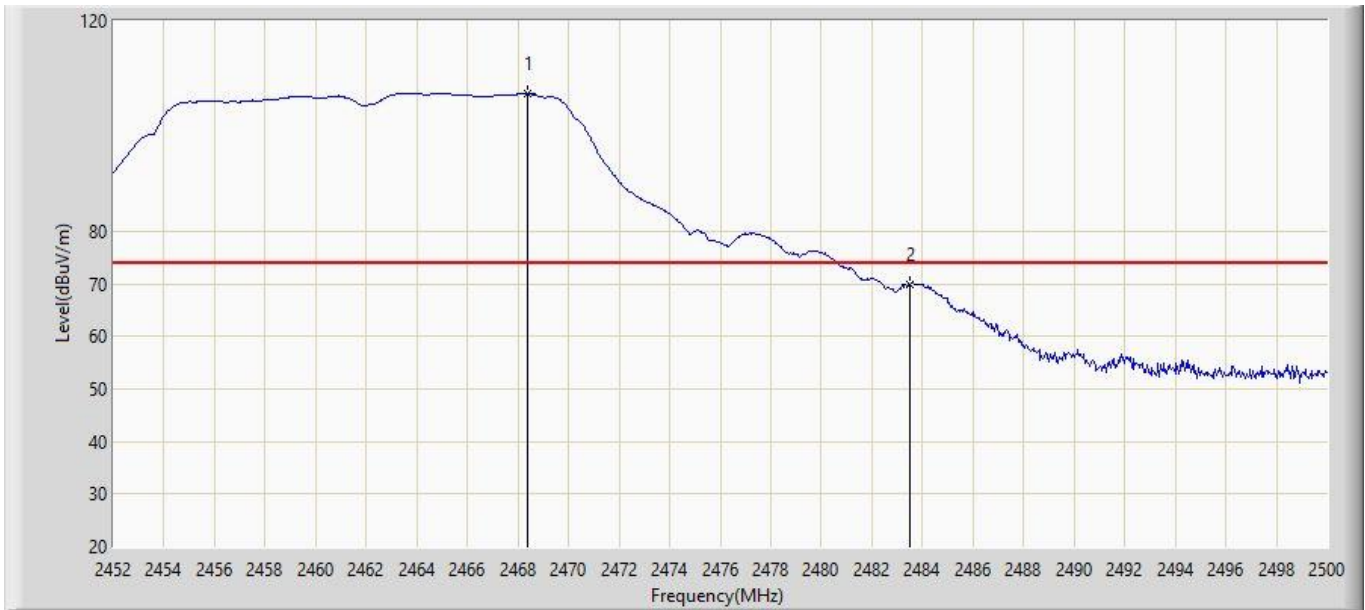

No	Mark	Frequency (MHz)	Measure Level (dBuV/m)	Reading Level (dBuV)	Over Limit (dB)	Limit (dBuV/m)	Factor (dB)	Type
1	*	2468.368	106.187	116.278	N/A	N/A	-10.091	PK
2		2483.500	69.927	79.950	-4.073	74.000	-10.023	PK

Note: Measure Level (dBuV/m) = Reading Level (dBuV) + Factor (dB)

Factor (dB) = Cable Loss (dB) + Antenna Factor (dB/m) - Pre_Amplifier Gain (dB)



Engineer: Kerry	
Site: AC102	Time: 2016/08/04 - 13:55
Limit: FCC_Part15.209_RE(3m)	Margin: 0
Probe: BBHA9120D(1-18GHz)	Polarity: Horizontal
EUT: 1080P Pan/Tilt Wireless IP Camera;720P Pan/Tilt Wireless IP Camera	Power: AC 120V/60Hz
Note: Mode:Transmit 802.11g at 2462MHz	

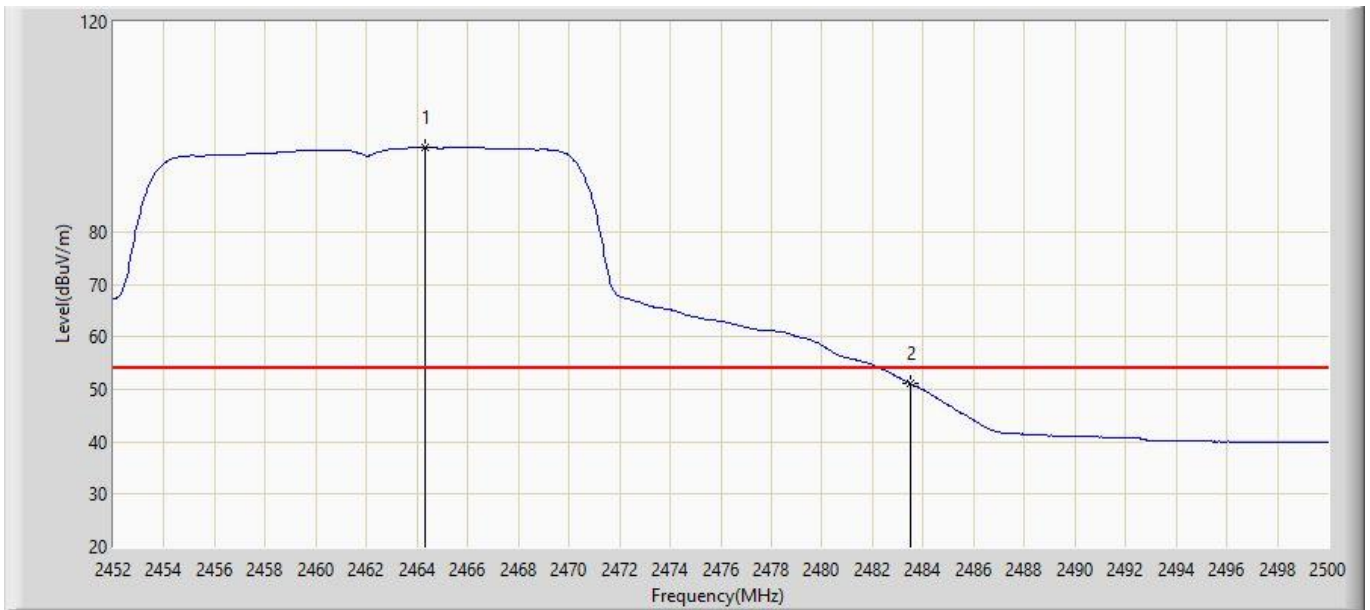

No	Mark	Frequency (MHz)	Measure Level (dBuV/m)	Reading Level (dBuV)	Over Limit (dB)	Limit (dBuV/m)	Factor (dB)	Type
1	*	2464.288	96.162	106.271	N/A	N/A	-10.109	AV
2		2483.500	51.054	61.077	-2.946	54.000	-10.023	AV

Note: Measure Level (dBuV/m) = Reading Level (dBuV) + Factor (dB)

Factor (dB) = Cable Loss (dB) + Antenna Factor (dB/m) - Pre_Amplifier Gain (dB)



Engineer: Kerry	
Site: AC102	Time: 2016/08/04 - 13:57
Limit: FCC_Part15.209_RE(3m)	Margin: 0
Probe: BBHA9120D(1-18GHz)	Polarity: Vertical
EUT: 1080P Pan/Tilt Wireless IP Camera;720P Pan/Tilt Wireless IP Camera	Power: AC 120V/60Hz
Note: Mode:Transmit 802.11g at 2462MHz	

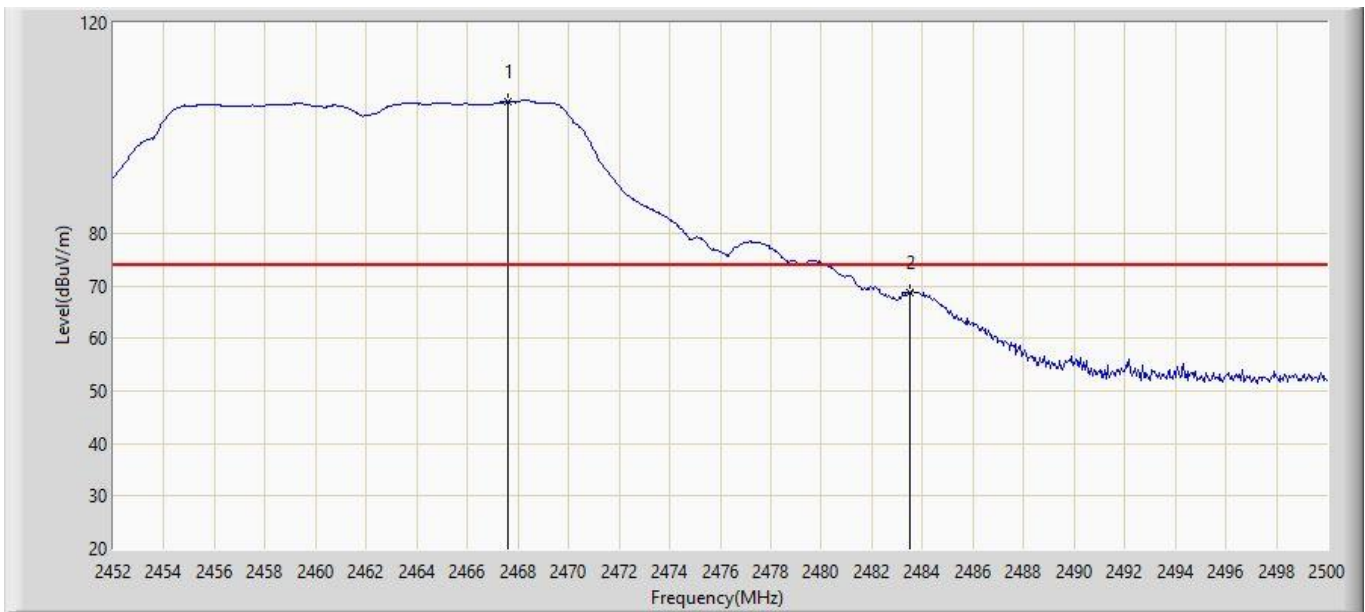

No	Mark	Frequency (MHz)	Measure Level (dBuV/m)	Reading Level (dBuV)	Over Limit (dB)	Limit (dBuV/m)	Factor (dB)	Type
1	*	2467.600	104.949	115.043	N/A	N/A	-10.094	PK
2		2483.500	68.713	78.736	-5.287	74.000	-10.023	PK

Note: Measure Level (dBuV/m) = Reading Level (dBuV) + Factor (dB)

Factor (dB) = Cable Loss (dB) + Antenna Factor (dB/m) - Pre_Amplifier Gain (dB)



Engineer: Kerry	
Site: AC102	Time: 2016/08/04 - 13:58
Limit: FCC_Part15.209_RE(3m)	Margin: 0
Probe: BBHA9120D(1-18GHz)	Polarity: Vertical
EUT: 1080P Pan/Tilt Wireless IP Camera;720P Pan/Tilt Wireless IP Camera	Power: AC 120V/60Hz
Note: Mode:Transmit 802.11g at 2462MHz	

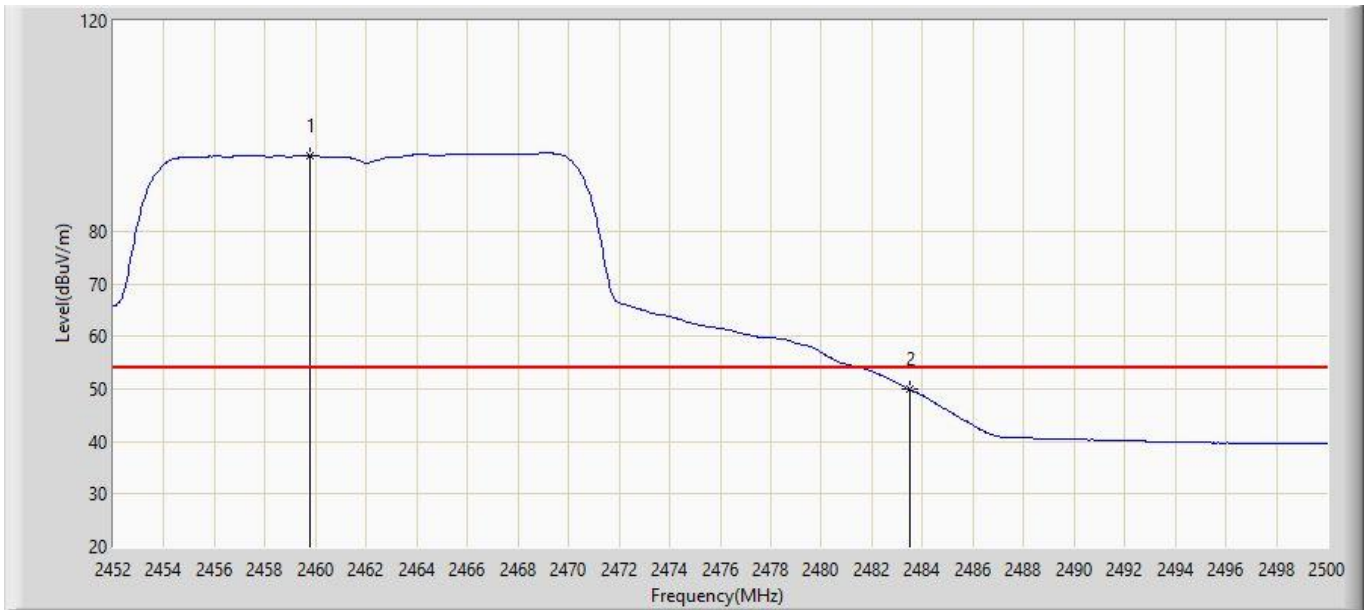

No	Mark	Frequency (MHz)	Measure Level (dBuV/m)	Reading Level (dBuV)	Over Limit (dB)	Limit (dBuV/m)	Factor (dB)	Type
1	*	2459.776	94.420	104.549	N/A	N/A	-10.129	AV
2		2483.500	49.839	59.862	-4.161	54.000	-10.023	AV

Note: Measure Level (dBuV/m) = Reading Level (dBuV) + Factor (dB)

Factor (dB) = Cable Loss (dB) + Antenna Factor (dB/m) - Pre_Amplifier Gain (dB)



Engineer: Kerry	
Site: AC102	Time: 2016/08/04 - 13:59
Limit: FCC_Part15.209_RE(3m)	Margin: 0
Probe: BBHA9120D(1-18GHz)	Polarity: Horizontal
EUT: 1080P Pan/Tilt Wireless IP Camera;720P Pan/Tilt Wireless IP Camera	Power: AC 120V/60Hz
Note: Mode:Transmit 802.11n(20MHz) at 2412MHz	

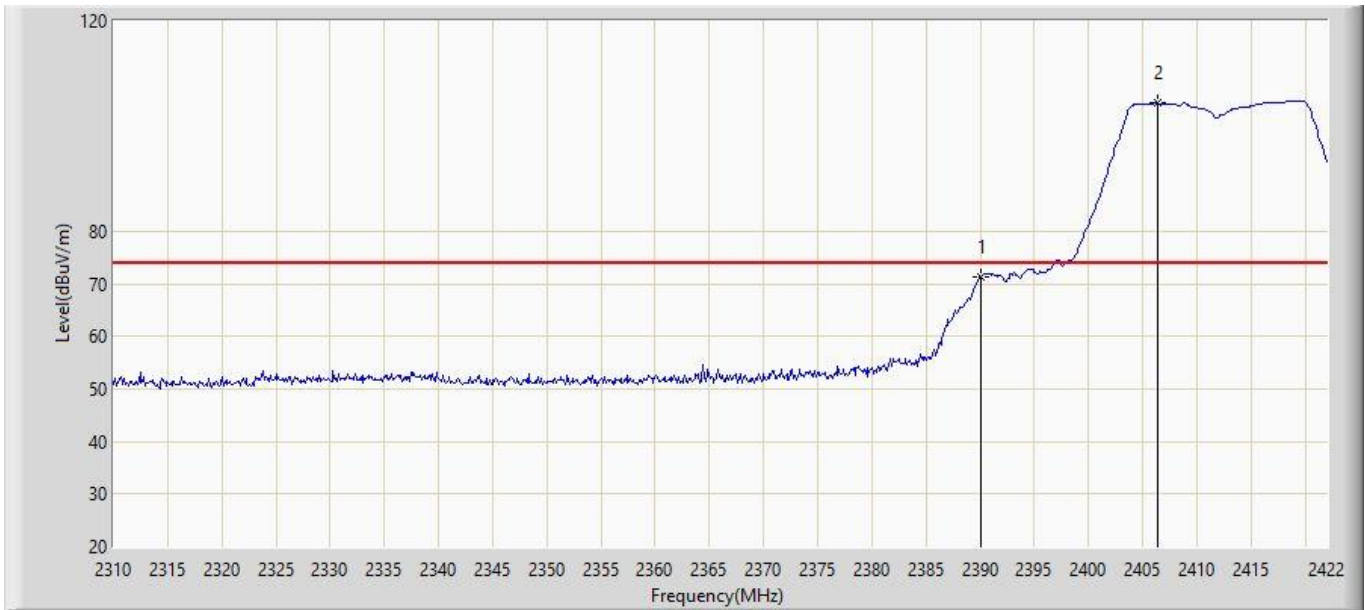

No	Mark	Frequency (MHz)	Measure Level (dBuV/m)	Reading Level (dBuV)	Over Limit (dB)	Limit (dBuV/m)	Factor (dB)	Type
1		2390.000	71.331	81.770	-2.669	74.000	-10.439	PK
2	*	2406.320	104.335	114.701	N/A	N/A	-10.366	PK

Note: Measure Level (dBuV/m) = Reading Level (dBuV) + Factor (dB)

Factor (dB) = Cable Loss (dB) + Antenna Factor (dB/m) - Pre_Amplifier Gain (dB)



Engineer: Kerry	
Site: AC102	Time: 2016/08/04 - 14:02
Limit: FCC_Part15.209_RE(3m)	Margin: 0
Probe: BBHA9120D(1-18GHz)	Polarity: Horizontal
EUT: 1080P Pan/Tilt Wireless IP Camera;720P Pan/Tilt Wireless IP Camera	Power: AC 120V/60Hz
Note: Mode:Transmit 802.11n(20MHz) at 2412MHz	

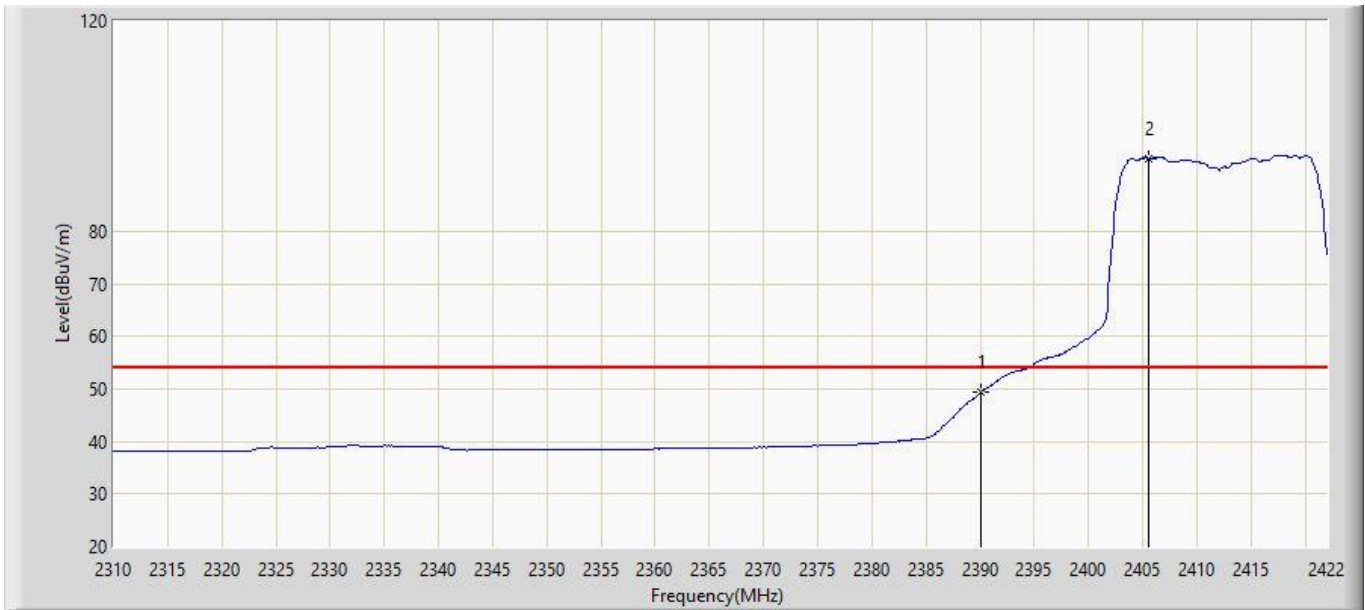

No	Mark	Frequency (MHz)	Measure Level (dBuV/m)	Reading Level (dBuV)	Over Limit (dB)	Limit (dBuV/m)	Factor (dB)	Type
1		2390.000	49.304	59.743	-4.696	54.000	-10.439	AV
2	*	2405.536	93.862	104.231	N/A	N/A	-10.369	AV

Note: Measure Level (dBuV/m) = Reading Level (dBuV) + Factor (dB)

Factor (dB) = Cable Loss (dB) + Antenna Factor (dB/m) - Pre_Amplifier Gain (dB)



Engineer: Kerry	
Site: AC102	Time: 2016/08/04 - 14:03
Limit: FCC_Part15.209_RE(3m)	Margin: 0
Probe: BBHA9120D(1-18GHz)	Polarity: Vertical
EUT: 1080P Pan/Tilt Wireless IP Camera;720P Pan/Tilt Wireless IP Camera	Power: AC 120V/60Hz
Note: Mode:Transmit 802.11n(20MHz) at 2412MHz	

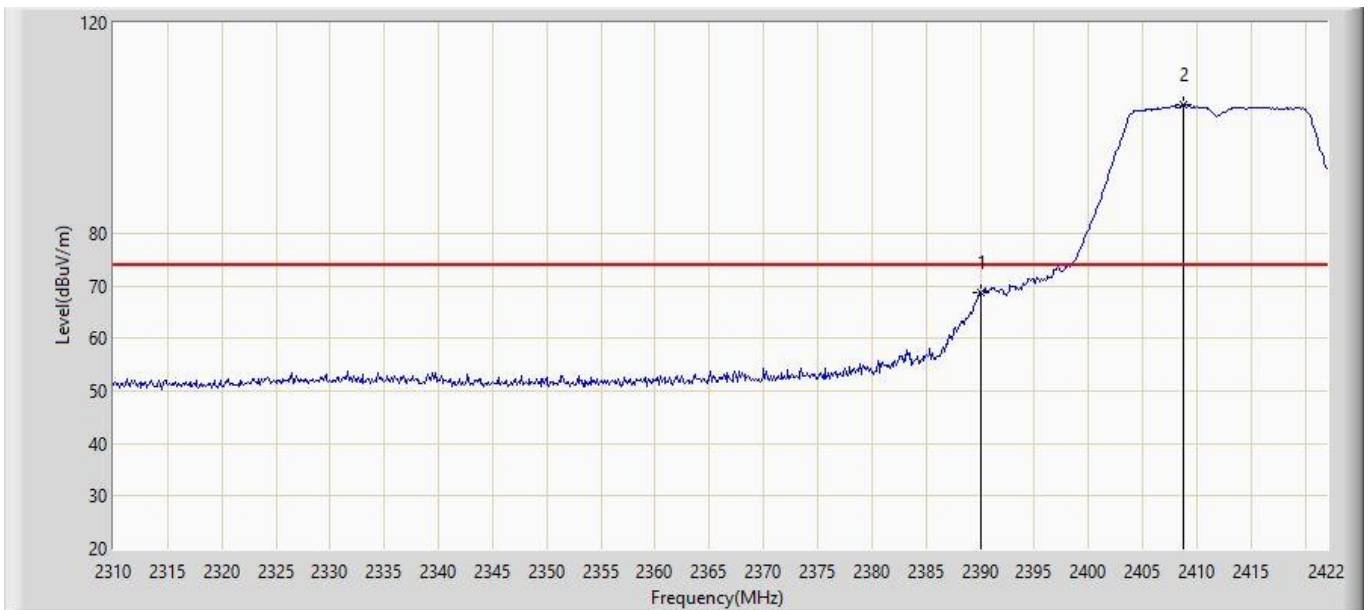

No	Mark	Frequency (MHz)	Measure Level (dBuV/m)	Reading Level (dBuV)	Over Limit (dB)	Limit (dBuV/m)	Factor (dB)	Type
1		2390.000	68.676	79.115	-5.324	74.000	-10.439	PK
2	*	2408.784	104.423	114.778	N/A	N/A	-10.355	PK

Note: Measure Level (dBuV/m) = Reading Level (dBuV) + Factor (dB)

Factor (dB) = Cable Loss (dB) + Antenna Factor (dB/m) - Pre_Amplifier Gain (dB)



Engineer: Kerry	
Site: AC102	Time: 2016/08/04 - 14:05
Limit: FCC_Part15.209_RE(3m)	Margin: 0
Probe: BBHA9120D(1-18GHz)	Polarity: Vertical
EUT: 1080P Pan/Tilt Wireless IP Camera;720P Pan/Tilt Wireless IP Camera	Power: AC 120V/60Hz
Note: Mode:Transmit 802.11n(20MHz) at 2412MHz	

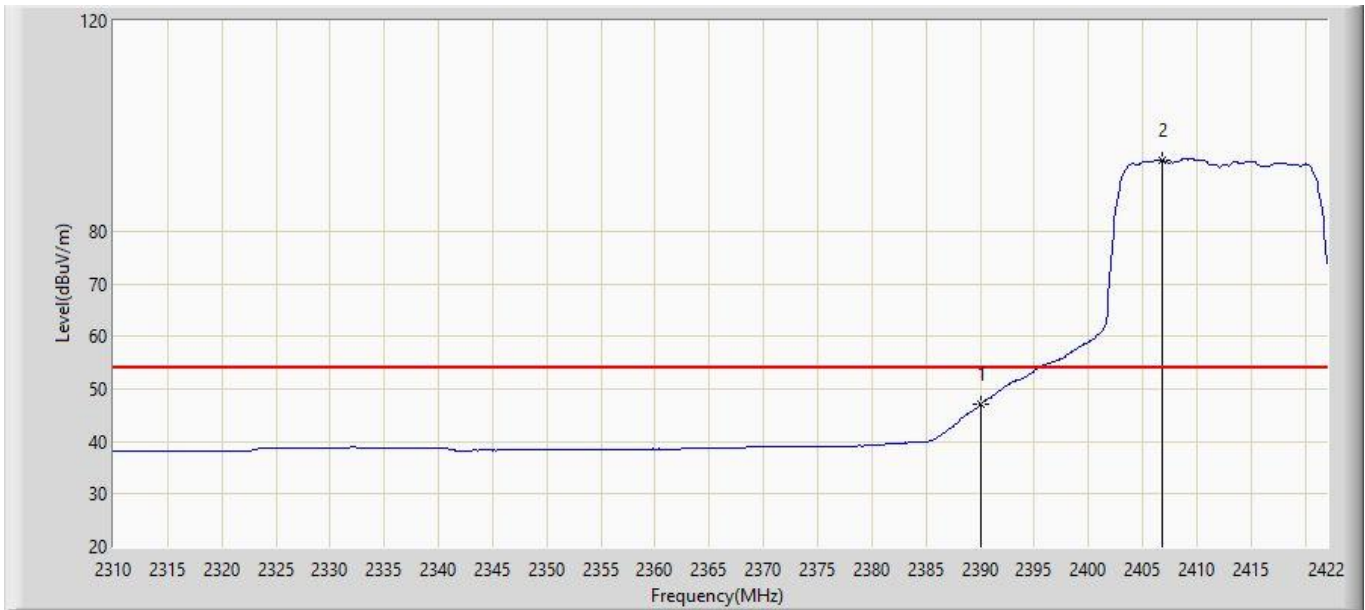

No	Mark	Frequency (MHz)	Measure Level (dBuV/m)	Reading Level (dBuV)	Over Limit (dB)	Limit (dBuV/m)	Factor (dB)	Type
1		2390.000	47.019	57.458	-6.981	54.000	-10.439	AV
2	*	2406.768	93.532	103.896	N/A	N/A	-10.364	AV

Note: Measure Level (dBuV/m) = Reading Level (dBuV) + Factor (dB)

Factor (dB) = Cable Loss (dB) + Antenna Factor (dB/m) - Pre_Amplifier Gain (dB)



Engineer: Kerry	
Site: AC102	Time: 2016/08/04 - 14:06
Limit: FCC_Part15.209_RE(3m)	Margin: 0
Probe: BBHA9120D(1-18GHz)	Polarity: Horizontal
EUT: 1080P Pan/Tilt Wireless IP Camera;720P Pan/Tilt Wireless IP Camera	Power: AC 120V/60Hz
Note: Mode:Transmit 802.11n(20MHz) at 2462MHz	

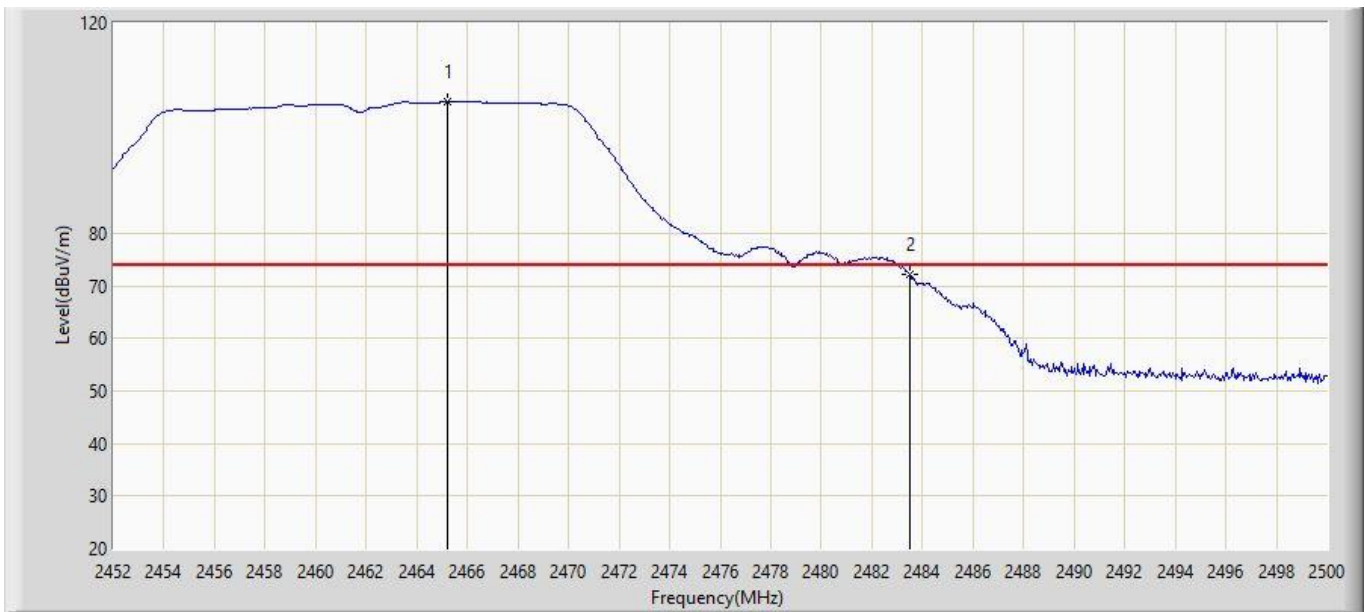

No	Mark	Frequency (MHz)	Measure Level (dBuV/m)	Reading Level (dBuV)	Over Limit (dB)	Limit (dBuV/m)	Factor (dB)	Type
1	*	2465.200	104.972	115.077	N/A	N/A	-10.105	PK
2		2483.500	72.040	82.063	-1.960	74.000	-10.023	PK

Note: Measure Level (dBuV/m) = Reading Level (dBuV) + Factor (dB)

Factor (dB) = Cable Loss (dB) + Antenna Factor (dB/m) - Pre_Amplifier Gain (dB)



Engineer: Kerry	
Site: AC102	Time: 2016/08/04 - 14:09
Limit: FCC_Part15.209_RE(3m)	Margin: 0
Probe: BBHA9120D(1-18GHz)	Polarity: Horizontal
EUT: 1080P Pan/Tilt Wireless IP Camera;720P Pan/Tilt Wireless IP Camera	Power: AC 120V/60Hz
Note: Mode:Transmit 802.11n(20MHz) at 2462MHz	

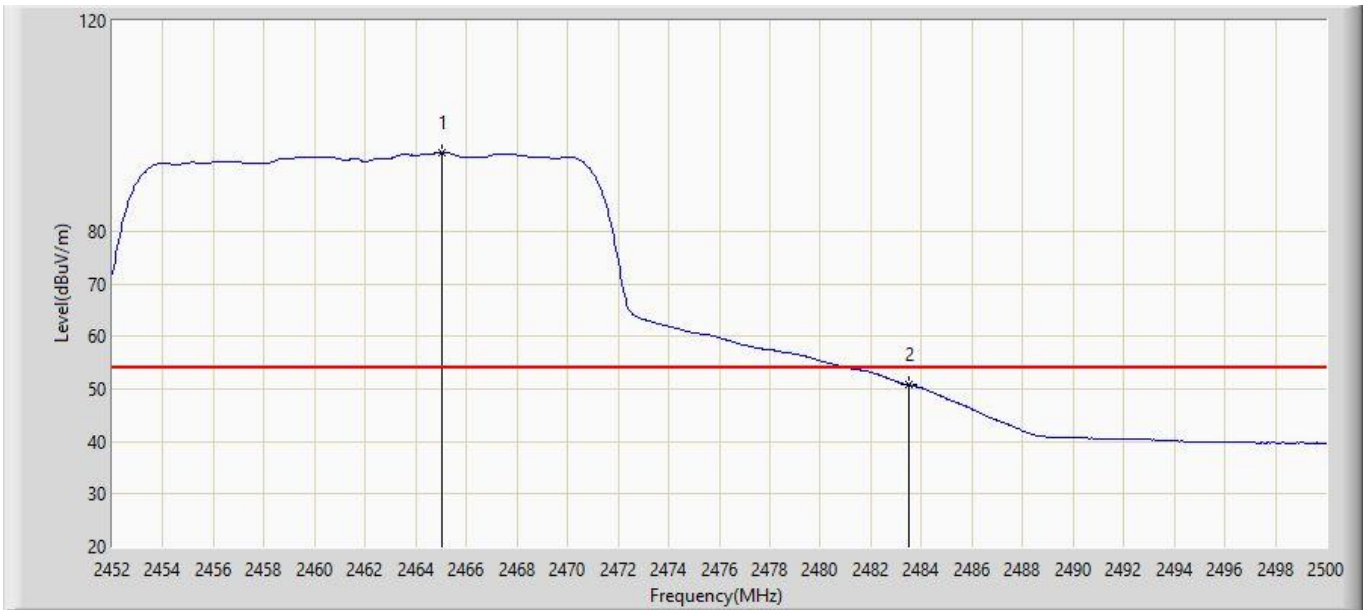

No	Mark	Frequency (MHz)	Measure Level (dBuV/m)	Reading Level (dBuV)	Over Limit (dB)	Limit (dBuV/m)	Factor (dB)	Type
1	*	2465.056	94.880	104.985	N/A	N/A	-10.105	AV
2		2483.500	50.718	60.741	-3.282	54.000	-10.023	AV

Note: Measure Level (dBuV/m) = Reading Level (dBuV) + Factor (dB)

Factor (dB) = Cable Loss (dB) + Antenna Factor (dB/m) - Pre_Amplifier Gain (dB)



Engineer: Kerry	
Site: AC102	Time: 2016/08/04 - 14:10
Limit: FCC_Part15.209_RE(3m)	Margin: 0
Probe: BBHA9120D(1-18GHz)	Polarity: Vertical
EUT: 1080P Pan/Tilt Wireless IP Camera;720P Pan/Tilt Wireless IP Camera	Power: AC 120V/60Hz
Note: Mode:Transmit 802.11n(20MHz) at 2462MHz	

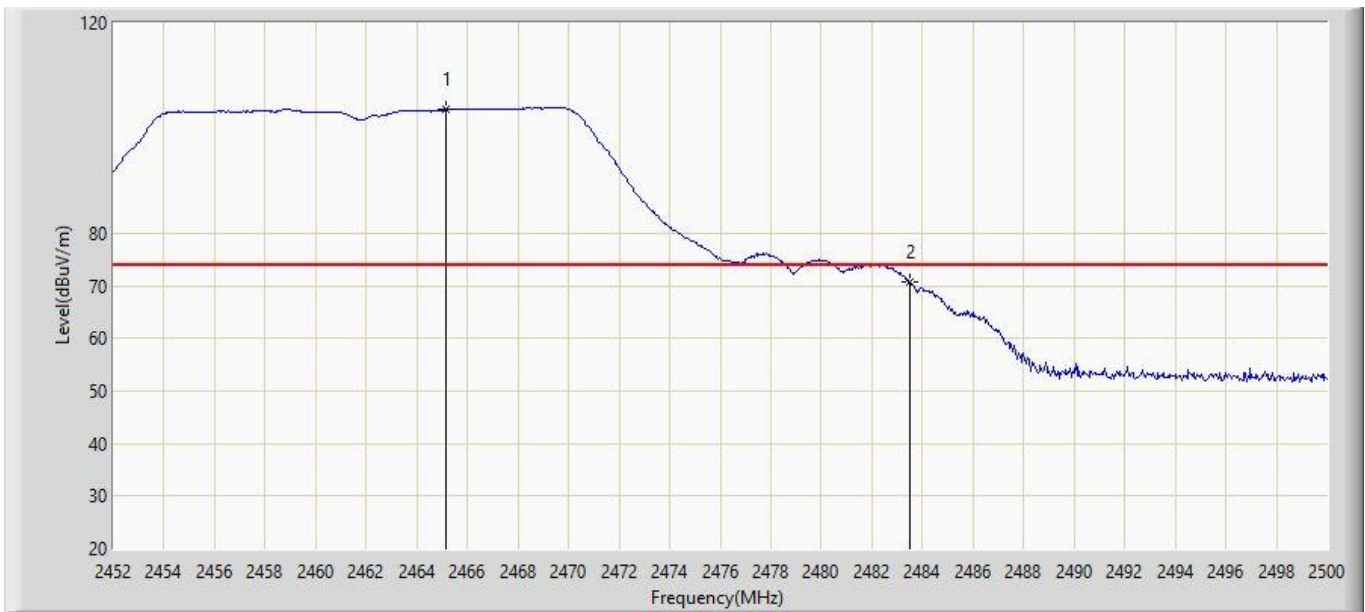

No	Mark	Frequency (MHz)	Measure Level (dBuV/m)	Reading Level (dBuV)	Over Limit (dB)	Limit (dBuV/m)	Factor (dB)	Type
1	*	2465.152	103.493	113.598	N/A	N/A	-10.105	PK
2		2483.500	70.728	80.751	-3.272	74.000	-10.023	PK

Note: Measure Level (dBuV/m) = Reading Level (dBuV) + Factor (dB)

Factor (dB) = Cable Loss (dB) + Antenna Factor (dB/m) - Pre_Amplifier Gain (dB)



Engineer: Kerry	
Site: AC102	Time: 2016/08/04 - 14:11
Limit: FCC_Part15.209_RE(3m)	Margin: 0
Probe: BBHA9120D(1-18GHz)	Polarity: Vertical
EUT: 1080P Pan/Tilt Wireless IP Camera;720P Pan/Tilt Wireless IP Camera	Power: AC 120V/60Hz
Note: Mode:Transmit 802.11n(20MHz) at 2462MHz	

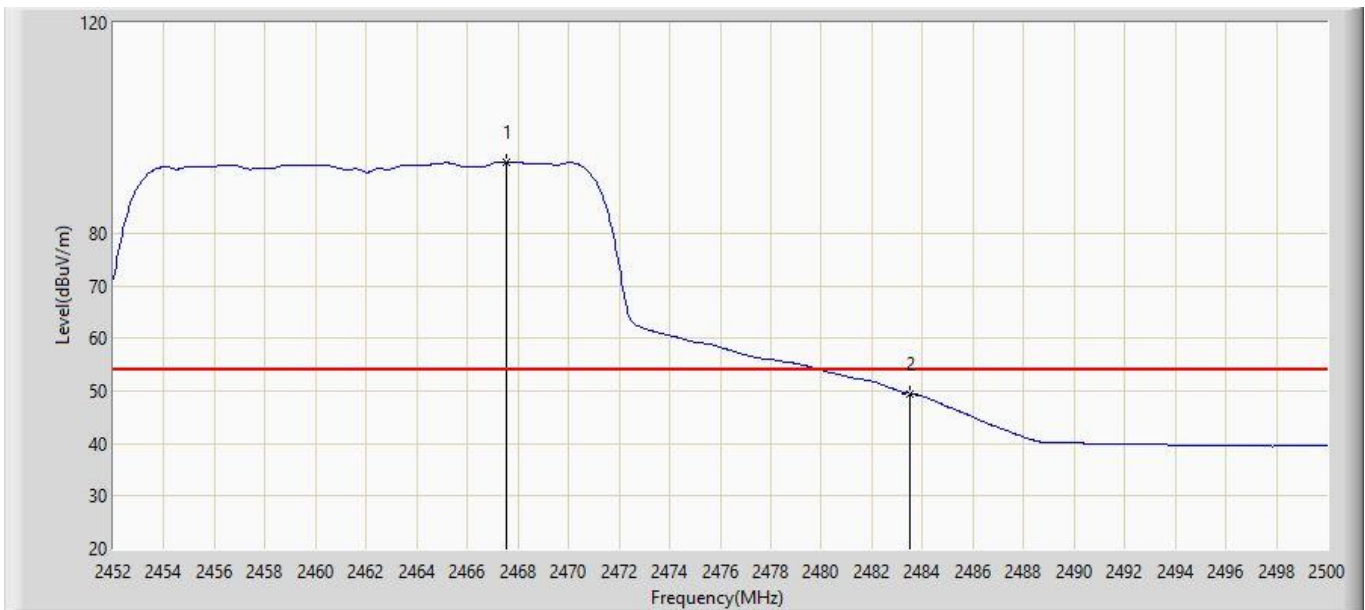

No	Mark	Frequency (MHz)	Measure Level (dBuV/m)	Reading Level (dBuV)	Over Limit (dB)	Limit (dBuV/m)	Factor (dB)	Type
1	*	2467.552	93.454	103.548	N/A	N/A	-10.094	AV
2		2483.500	49.504	59.527	-4.496	54.000	-10.023	AV

Note: Measure Level (dBuV/m) = Reading Level (dBuV) + Factor (dB)

Factor (dB) = Cable Loss (dB) + Antenna Factor (dB/m) - Pre_Amplifier Gain (dB)



Engineer: Kerry	
Site: AC102	Time: 2016/08/04 - 14:12
Limit: FCC_Part15.209_RE(3m)	Margin: 0
Probe: BBHA9120D(1-18GHz)	Polarity: Horizontal
EUT: 1080P Pan/Tilt Wireless IP Camera;720P Pan/Tilt Wireless IP Camera	Power: AC 120V/60Hz
Note: Mode:Transmit 802.11n(40MHz) at 2422MHz	

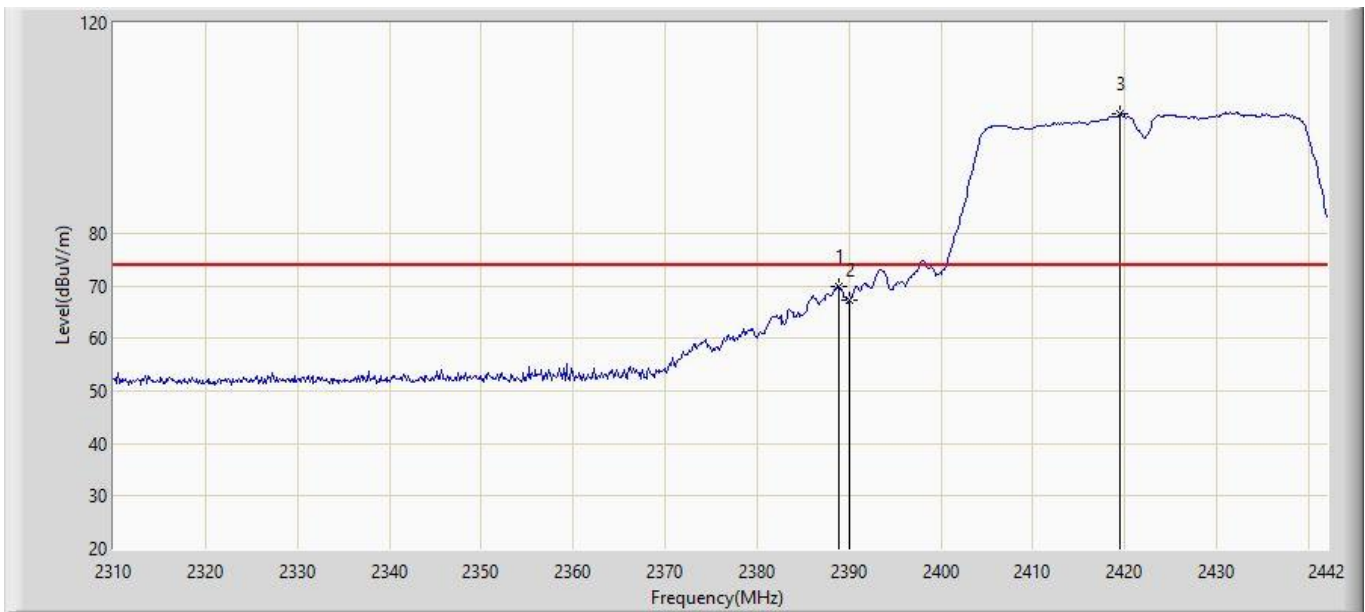

No	Mark	Frequency (MHz)	Measure Level (dBuV/m)	Reading Level (dBuV)	Over Limit (dB)	Limit (dBuV/m)	Factor (dB)	Type
1		2388.936	69.976	80.419	-4.024	74.000	-10.443	PK
2		2390.000	67.207	77.646	-6.793	74.000	-10.439	PK
3	*	2419.560	102.624	112.931	N/A	N/A	-10.307	PK

Note: Measure Level (dBuV/m) = Reading Level (dBuV) + Factor (dB)

Factor (dB) = Cable Loss (dB) + Antenna Factor (dB/m) - Pre_Amplifier Gain (dB)



Engineer: Kerry	
Site: AC102	Time: 2016/08/04 - 14:16
Limit: FCC_Part15.209_RE(3m)	Margin: 0
Probe: BBHA9120D(1-18GHz)	Polarity: Horizontal
EUT: 1080P Pan/Tilt Wireless IP Camera;720P Pan/Tilt Wireless IP Camera	Power: AC 120V/60Hz
Note: Mode:Transmit 802.11n(40MHz) at 2422MHz	

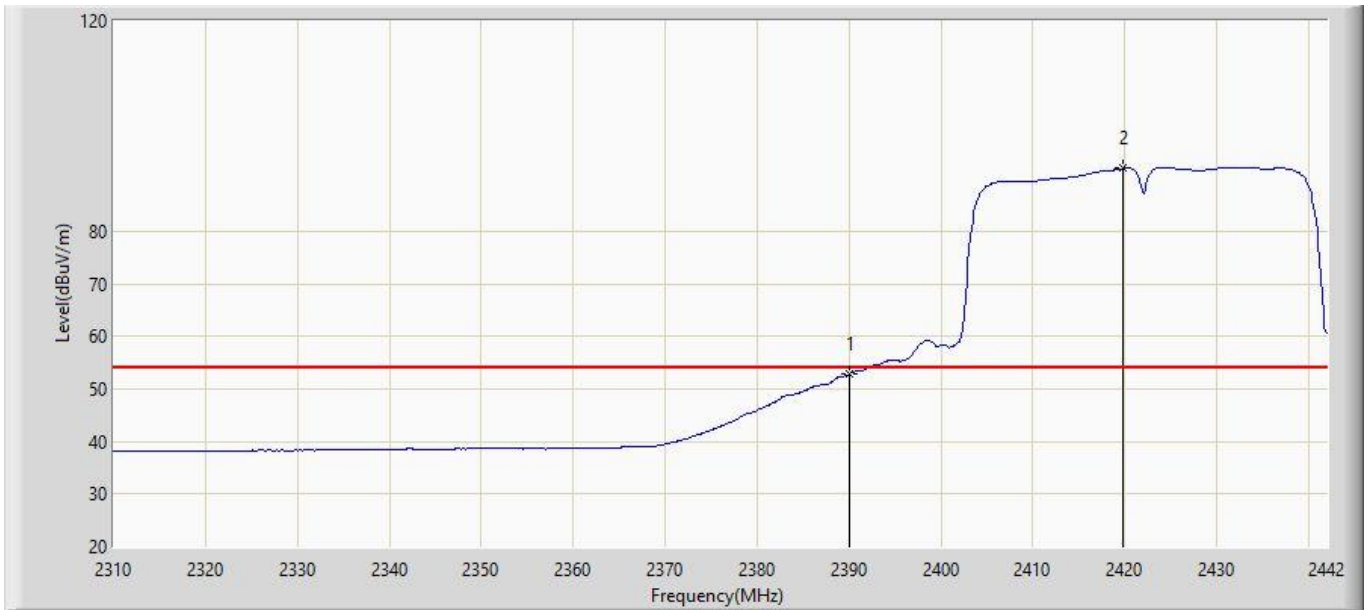

No	Mark	Frequency (MHz)	Measure Level (dBuV/m)	Reading Level (dBuV)	Over Limit (dB)	Limit (dBuV/m)	Factor (dB)	Type
1		2390.000	52.789	63.228	-1.211	54.000	-10.439	AV
2	*	2419.824	91.938	102.244	N/A	N/A	-10.306	AV

Note: Measure Level (dBuV/m) = Reading Level (dBuV) + Factor (dB)

Factor (dB) = Cable Loss (dB) + Antenna Factor (dB/m) - Pre_Amplifier Gain (dB)



Engineer: Kerry	
Site: AC102	Time: 2016/08/04 - 14:17
Limit: FCC_Part15.209_RE(3m)	Margin: 0
Probe: BBHA9120D(1-18GHz)	Polarity: Vertical
EUT: 1080P Pan/Tilt Wireless IP Camera;720P Pan/Tilt Wireless IP Camera	Power: AC 120V/60Hz
Note: Mode:Transmit 802.11n(40MHz) at 2422MHz	

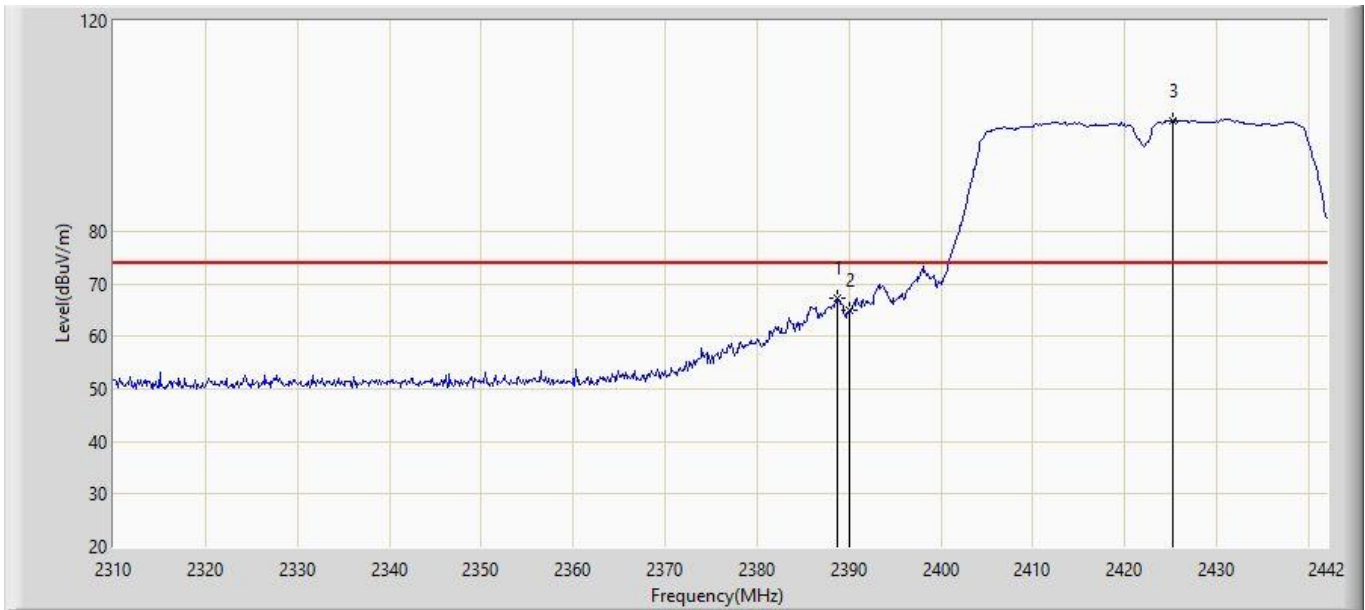

No	Mark	Frequency (MHz)	Measure Level (dBuV/m)	Reading Level (dBuV)	Over Limit (dB)	Limit (dBuV/m)	Factor (dB)	Type
1		2388.804	67.120	77.564	-6.880	74.000	-10.444	PK
2		2390.000	64.970	75.409	-9.030	74.000	-10.439	PK
3	*	2425.236	101.043	111.325	N/A	N/A	-10.282	PK

Note: Measure Level (dBµV/m) = Reading Level (dBµV) + Factor (dB)

Factor (dB) = Cable Loss (dB) + Antenna Factor (dB/m) - Pre_Amplifier Gain (dB)



Engineer: Kerry	
Site: AC102	Time: 2016/08/04 - 14:19
Limit: FCC_Part15.209_RE(3m)	Margin: 0
Probe: BBHA9120D(1-18GHz)	Polarity: Vertical
EUT: 1080P Pan/Tilt Wireless IP Camera;720P Pan/Tilt Wireless IP Camera	Power: AC 120V/60Hz
Note: Mode:Transmit 802.11n(40MHz) at 2422MHz	

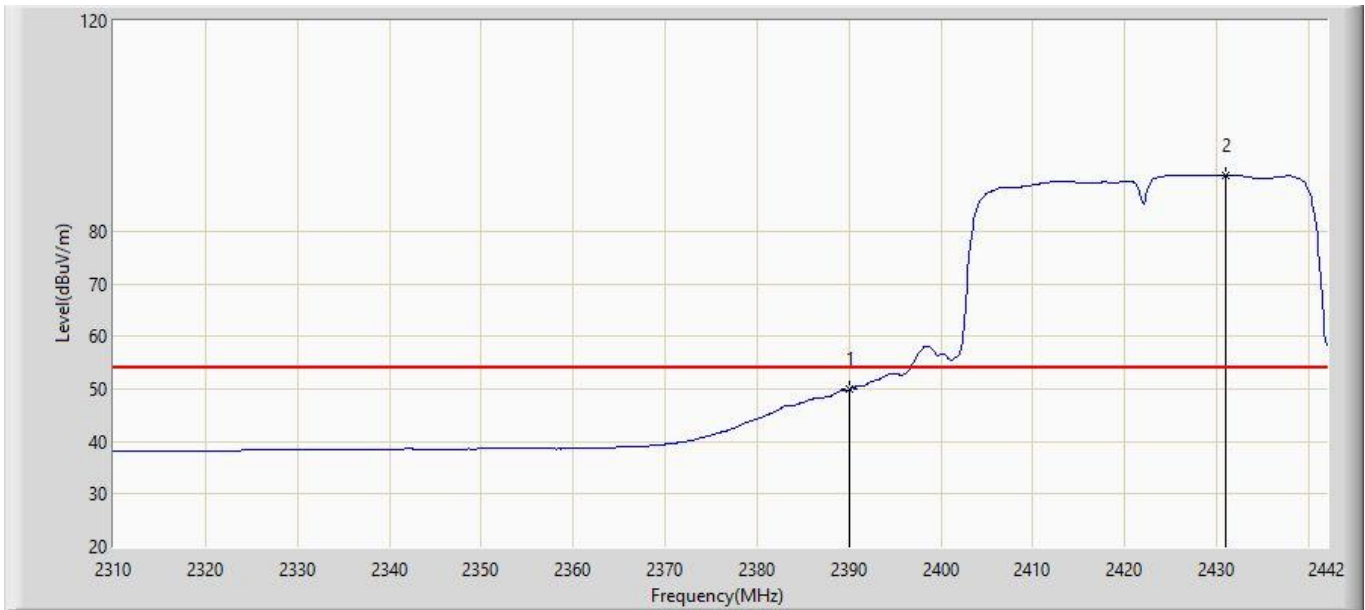

No	Mark	Frequency (MHz)	Measure Level (dBuV/m)	Reading Level (dBuV)	Over Limit (dB)	Limit (dBuV/m)	Factor (dB)	Type
1		2390.000	49.909	60.348	-4.091	54.000	-10.439	AV
2	*	2431.044	90.725	100.981	N/A	N/A	-10.256	AV

Note: Measure Level (dBuV/m) = Reading Level (dBuV) + Factor (dB)

Factor (dB) = Cable Loss (dB) + Antenna Factor (dB/m) - Pre_Amplifier Gain (dB)



Engineer: Kerry	
Site: AC102	Time: 2016/08/04 - 14:21
Limit: FCC_Part15.209_RE(3m)	Margin: 0
Probe: BBHA9120D(1-18GHz)	Polarity: Horizontal
EUT: 1080P Pan/Tilt Wireless IP Camera;720P Pan/Tilt Wireless IP Camera	Power: AC 120V/60Hz
Note: Mode:Transmit 802.11n(40MHz) at 2452MHz	

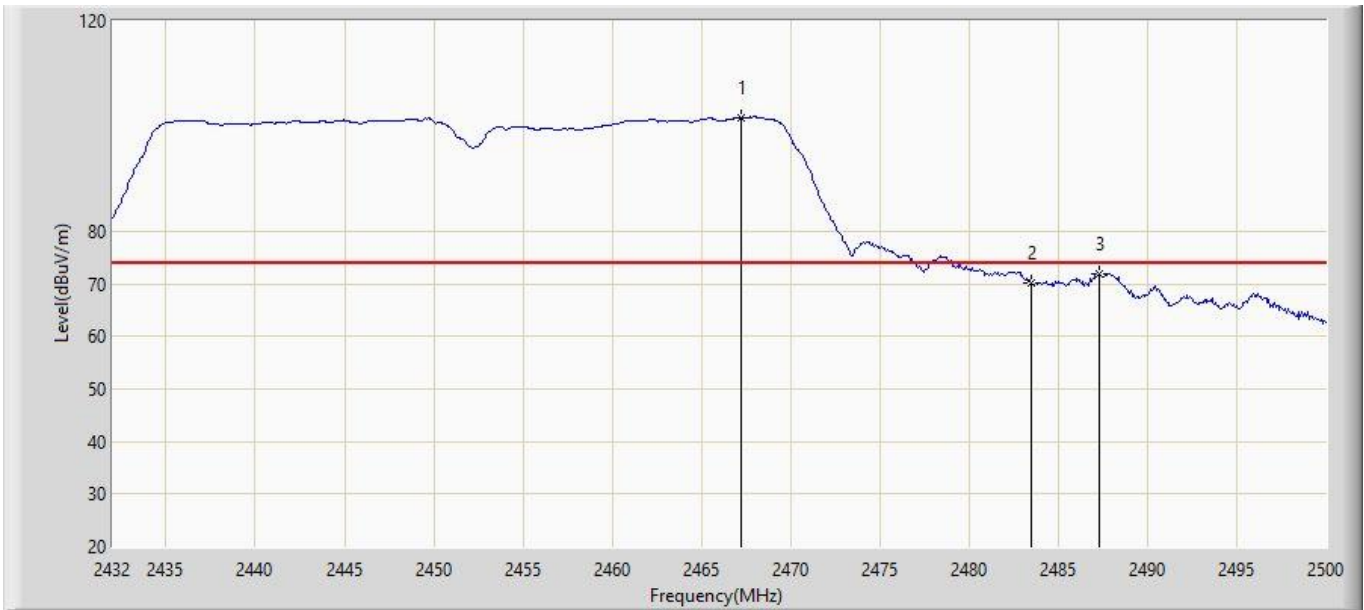

No	Mark	Frequency (MHz)	Measure Level (dBuV/m)	Reading Level (dBuV)	Over Limit (dB)	Limit (dBuV/m)	Factor (dB)	Type
1	*	2467.224	101.550	111.646	N/A	N/A	-10.096	PK
2		2483.500	70.097	80.120	-3.903	74.000	-10.023	PK
3		2487.284	71.730	81.736	-2.270	74.000	-10.006	PK

Note: Measure Level (dBμV/m) = Reading Level (dBμV) + Factor (dB)

Factor (dB) = Cable Loss (dB) + Antenna Factor (dB/m) - Pre_Amplifier Gain (dB)



Engineer: Kerry	
Site: AC102	Time: 2016/08/04 - 14:25
Limit: FCC_Part15.209_RE(3m)	Margin: 0
Probe: BBHA9120D(1-18GHz)	Polarity: Horizontal
EUT: 1080P Pan/Tilt Wireless IP Camera;720P Pan/Tilt Wireless IP Camera	Power: AC 120V/60Hz
Note: Mode:Transmit 802.11n(40MHz) at 2452MHz	

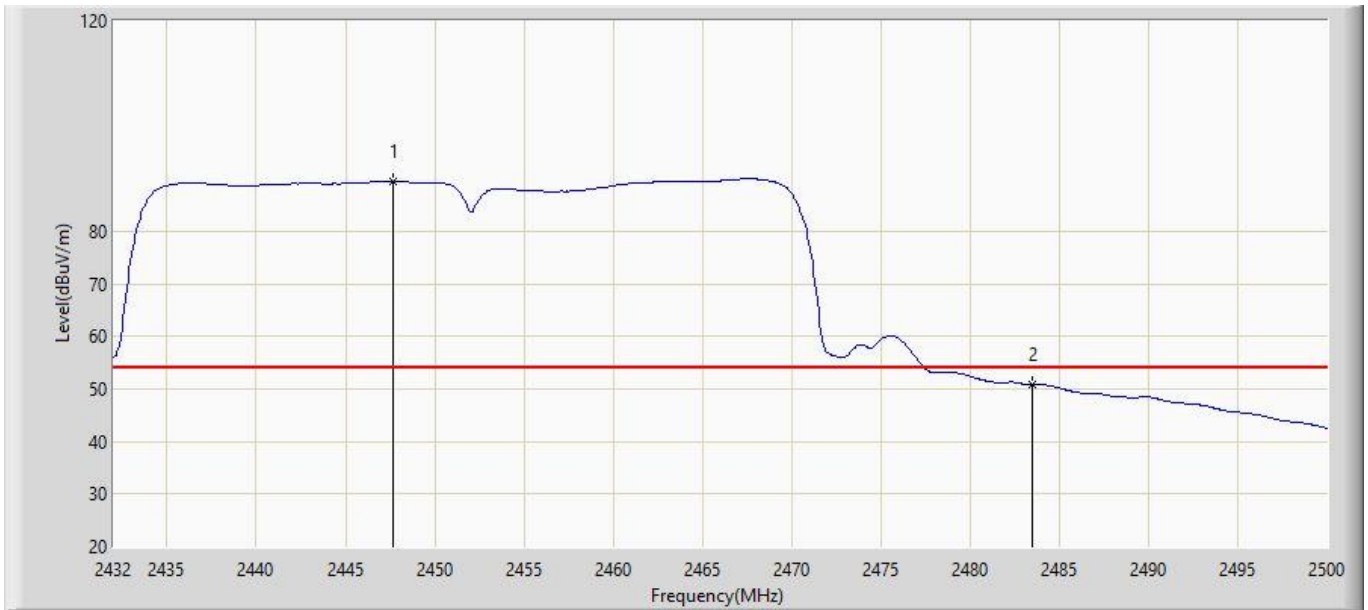

No	Mark	Frequency (MHz)	Measure Level (dBuV/m)	Reading Level (dBuV)	Over Limit (dB)	Limit (dBuV/m)	Factor (dB)	Type
1	*	2447.640	89.483	99.665	N/A	N/A	-10.182	AV
2		2483.500	50.847	60.870	-3.153	54.000	-10.023	AV

Note: Measure Level (dBuV/m) = Reading Level (dBuV) + Factor (dB)

Factor (dB) = Cable Loss (dB) + Antenna Factor (dB/m) - Pre_Amplifier Gain (dB)



Engineer: Kerry	
Site: AC102	Time: 2016/08/04 - 14:27
Limit: FCC_Part15.209_RE(3m)	Margin: 0
Probe: BBHA9120D(1-18GHz)	Polarity: Vertical
EUT: 1080P Pan/Tilt Wireless IP Camera;720P Pan/Tilt Wireless IP Camera	Power: AC 120V/60Hz
Note: Mode:Transmit 802.11n(40MHz) at 2452MHz	

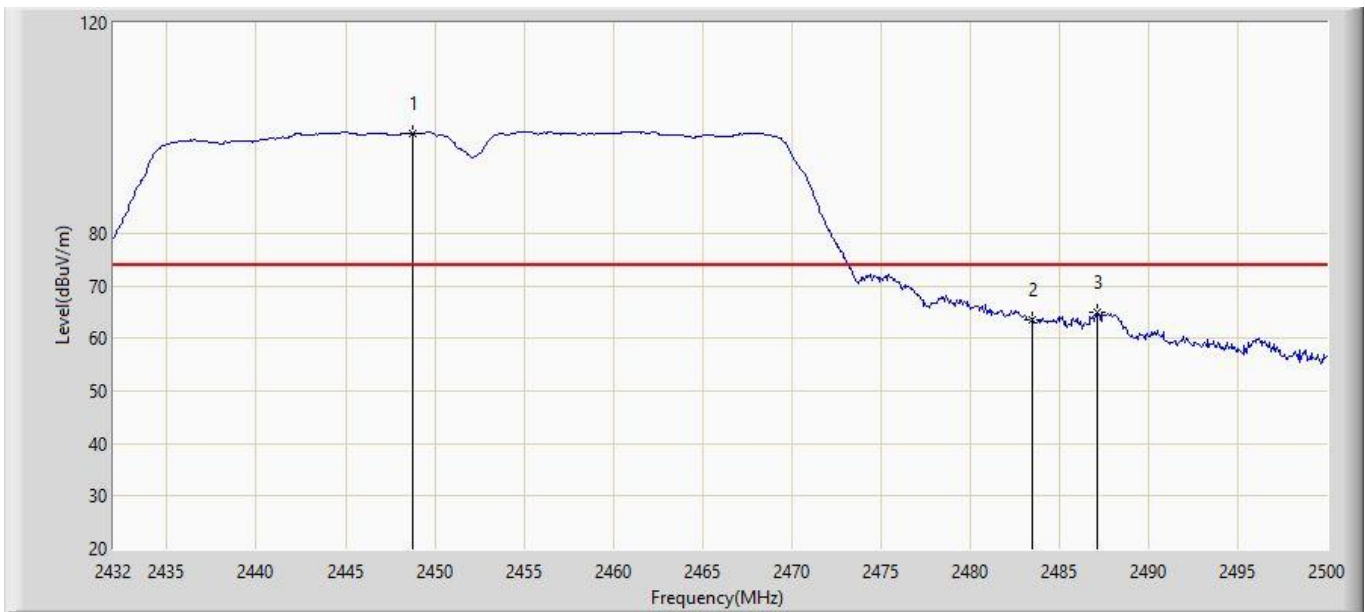

No	Mark	Frequency (MHz)	Measure Level (dBuV/m)	Reading Level (dBuV)	Over Limit (dB)	Limit (dBuV/m)	Factor (dB)	Type
1	*	2448.796	99.071	109.248	N/A	N/A	-10.177	PK
2		2483.500	63.598	73.621	-10.402	74.000	-10.023	PK
3		2487.148	64.970	74.977	-9.030	74.000	-10.007	PK

Note: Measure Level (dBuV/m) = Reading Level (dBuV) + Factor (dB)

Factor (dB) = Cable Loss (dB) + Antenna Factor (dB/m) - Pre_Amplifier Gain (dB)



Engineer: Kerry	
Site: AC102	Time: 2016/08/04 - 14:29
Limit: FCC_Part15.209_RE(3m)	Margin: 0
Probe: BBHA9120D(1-18GHz)	Polarity: Vertical
EUT: 1080P Pan/Tilt Wireless IP Camera;720P Pan/Tilt Wireless IP Camera	Power: AC 120V/60Hz
Note: Mode:Transmit 802.11n(40MHz) at 2452MHz	

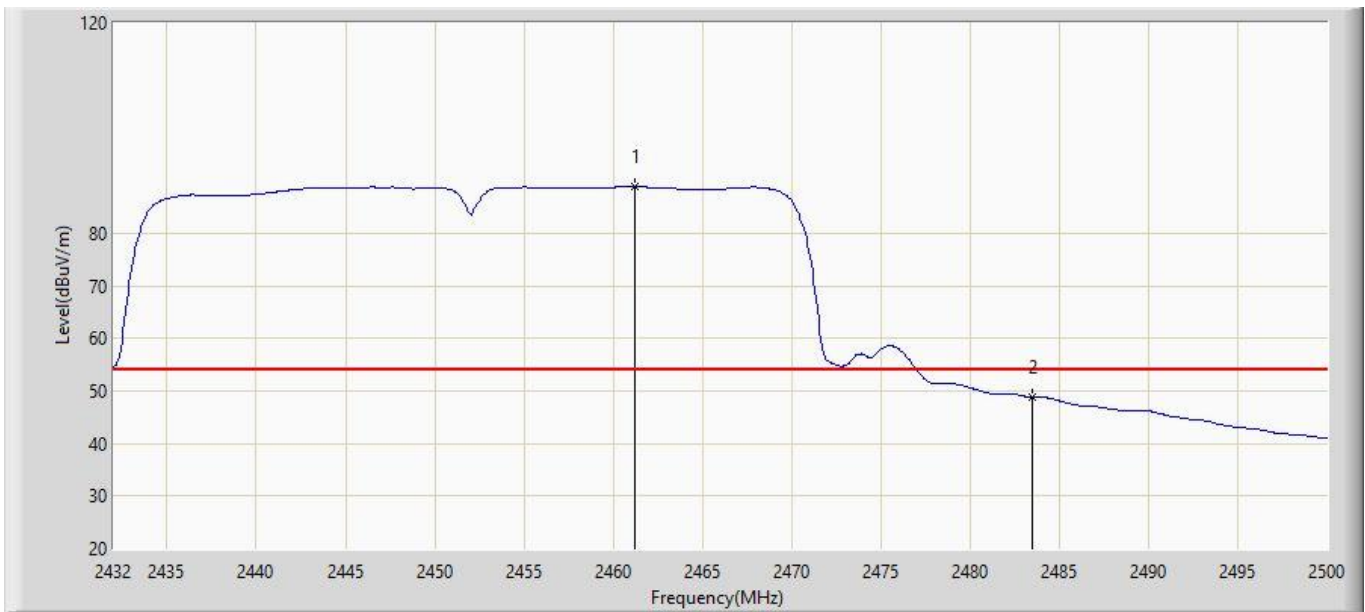

No	Mark	Frequency (MHz)	Measure Level (dBuV/m)	Reading Level (dBuV)	Over Limit (dB)	Limit (dBuV/m)	Factor (dB)	Type
1	*	2461.240	88.842	98.964	N/A	N/A	-10.122	AV
2		2483.500	48.879	58.902	-5.121	54.000	-10.023	AV

Note: Measure Level (dBuV/m) = Reading Level (dBuV) + Factor (dB)

Factor (dB) = Cable Loss (dB) + Antenna Factor (dB/m) - Pre_Amplifier Gain (dB)



Band Edge (20dBc RF Conducted Measurement)

Mode 1: Transmit by 802.11b (2412MHz)

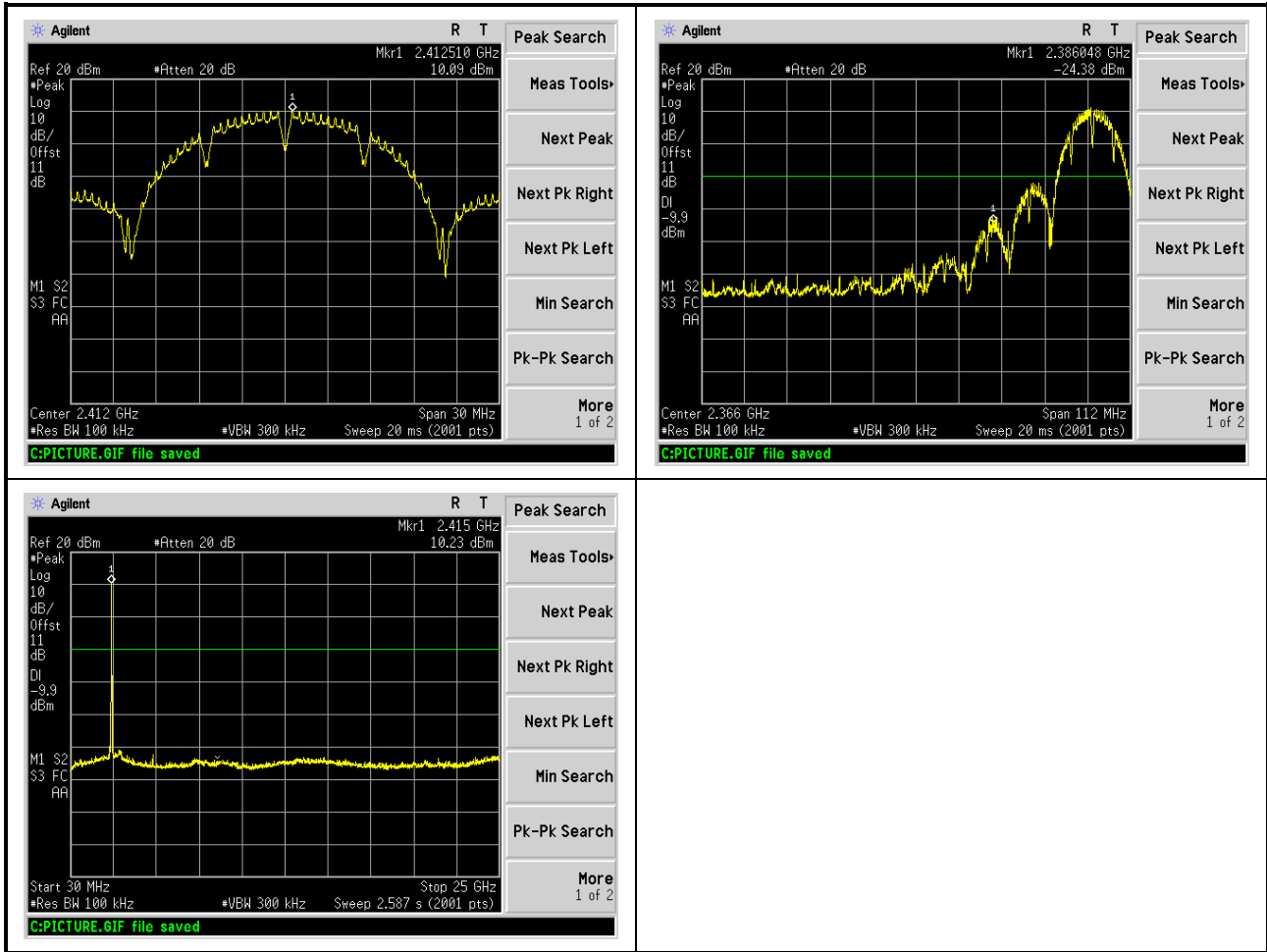



Mode 1: Transmit by 802.11b (2437MHz)

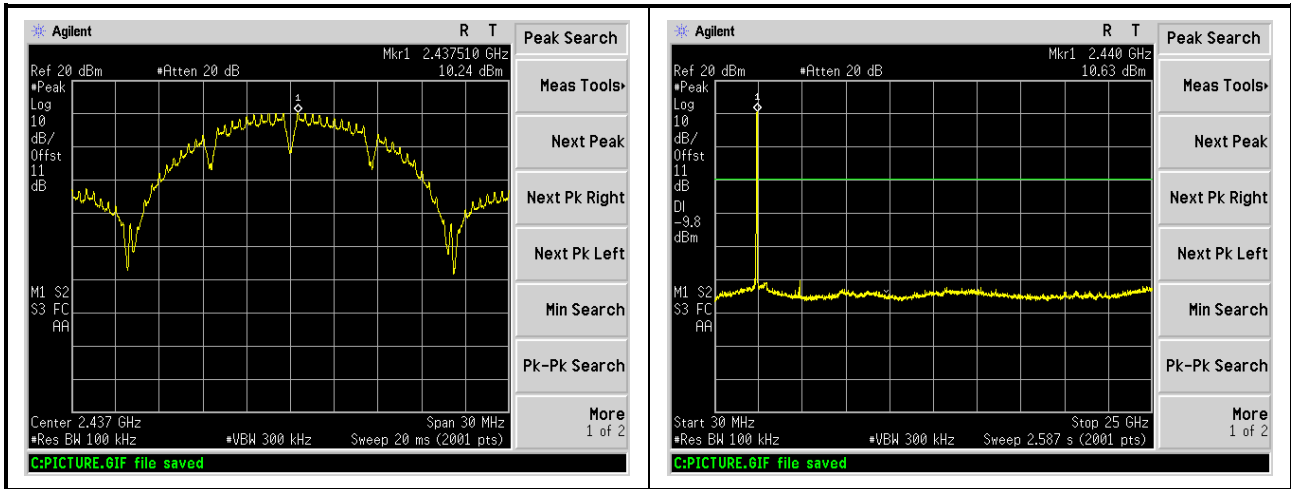

Mode 1: Transmit by 802.11b (2462MHz)

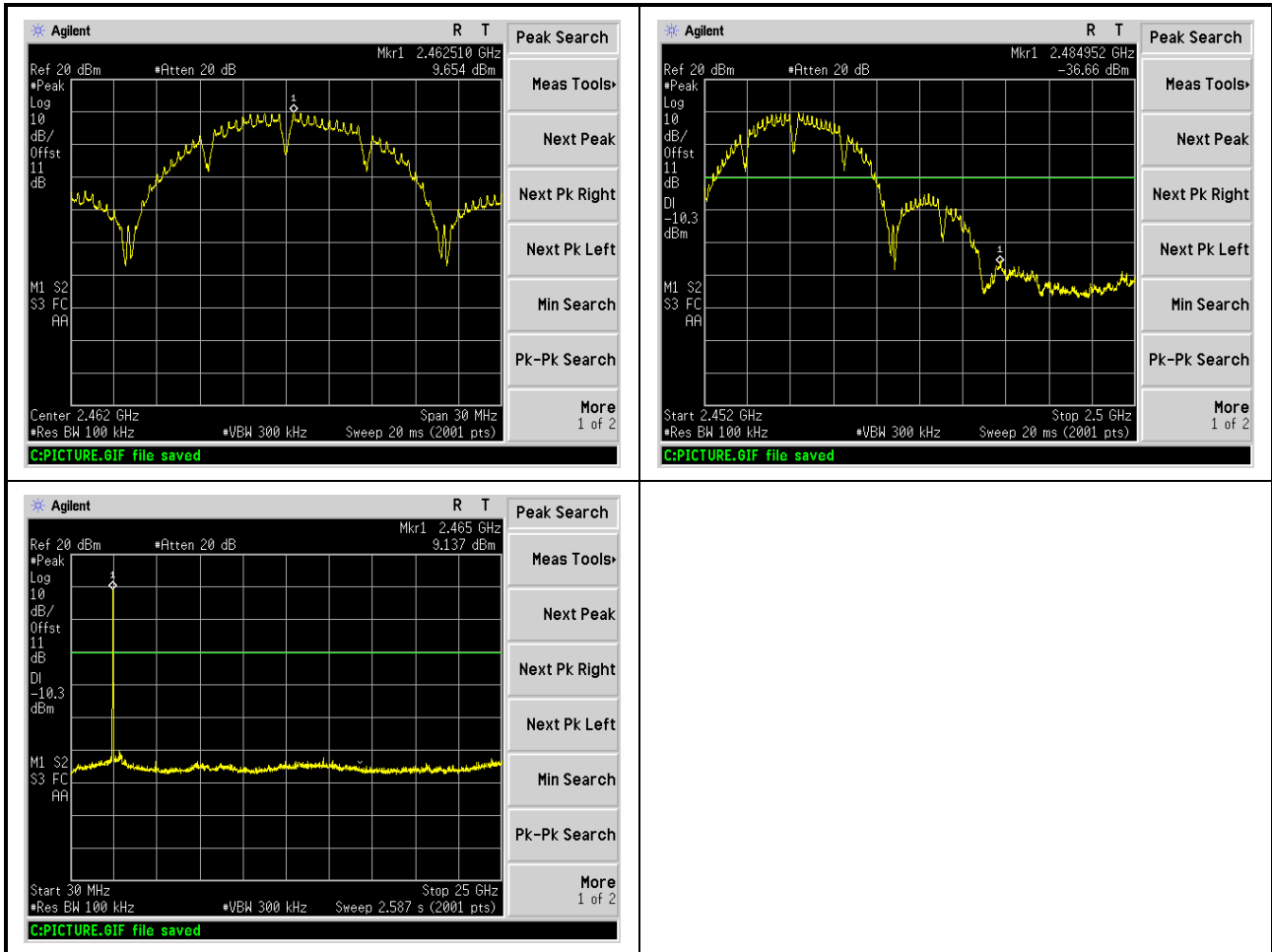



Mode 2: Transmit by 802.11g (2412MHz)

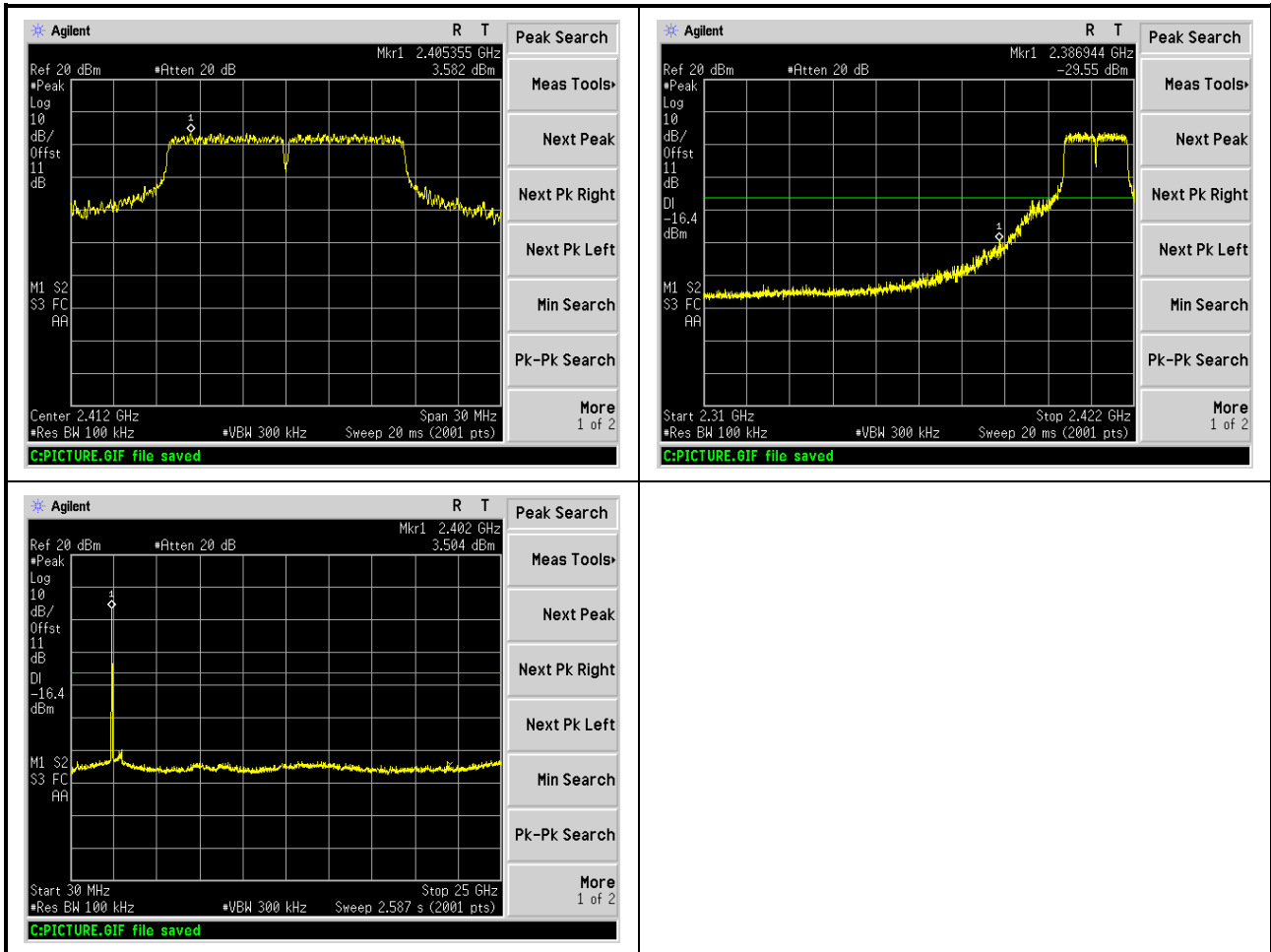



Mode 2: Transmit by 802.11g (2437MHz)

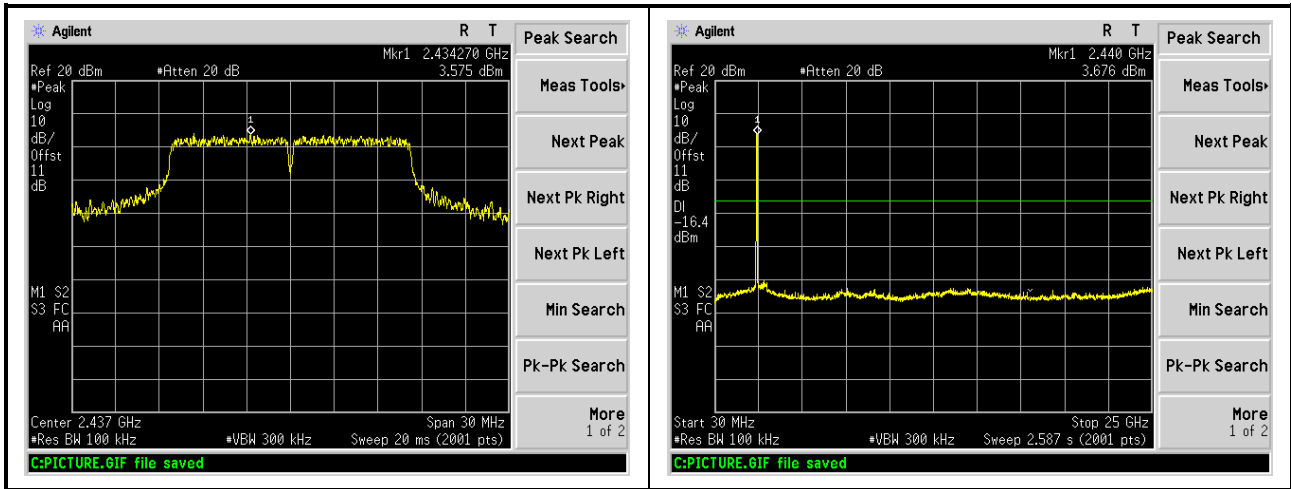

Mode 2: Transmit by 802.11g (2462MHz)

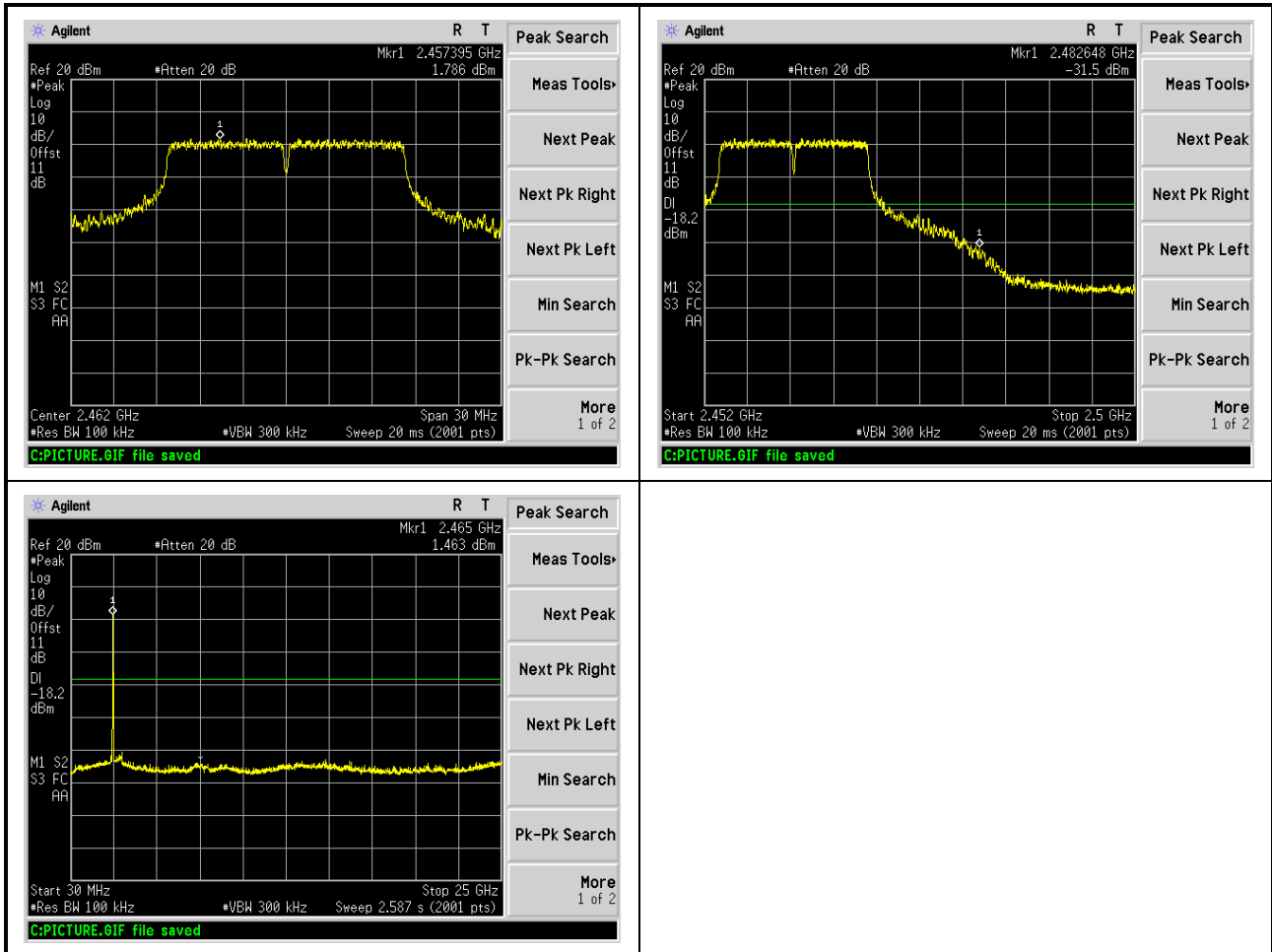



Mode 3: Transmit by 802.11n20 (2412MHz)

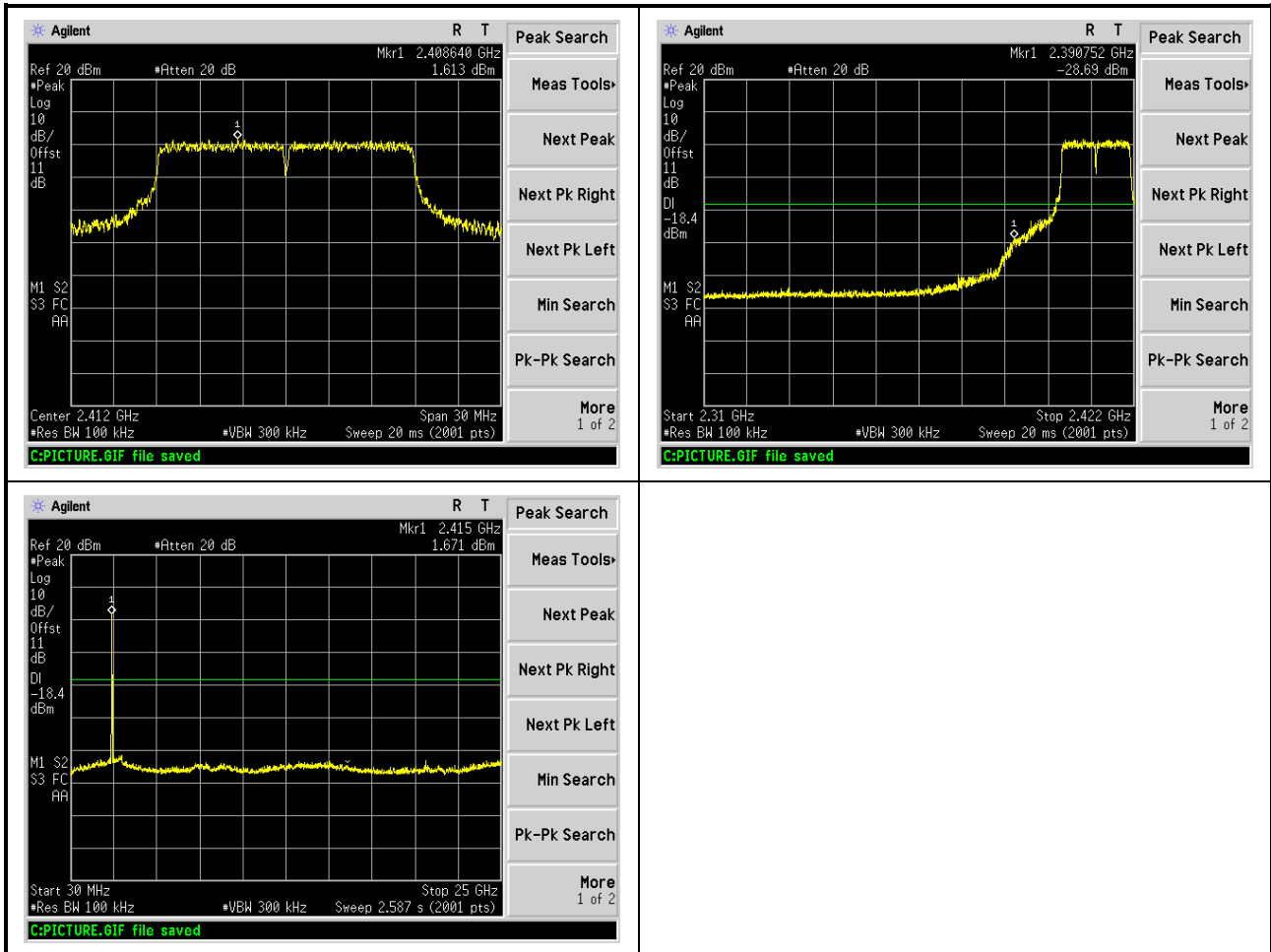



Mode 3: Transmit by 802.11n20 (2437MHz)

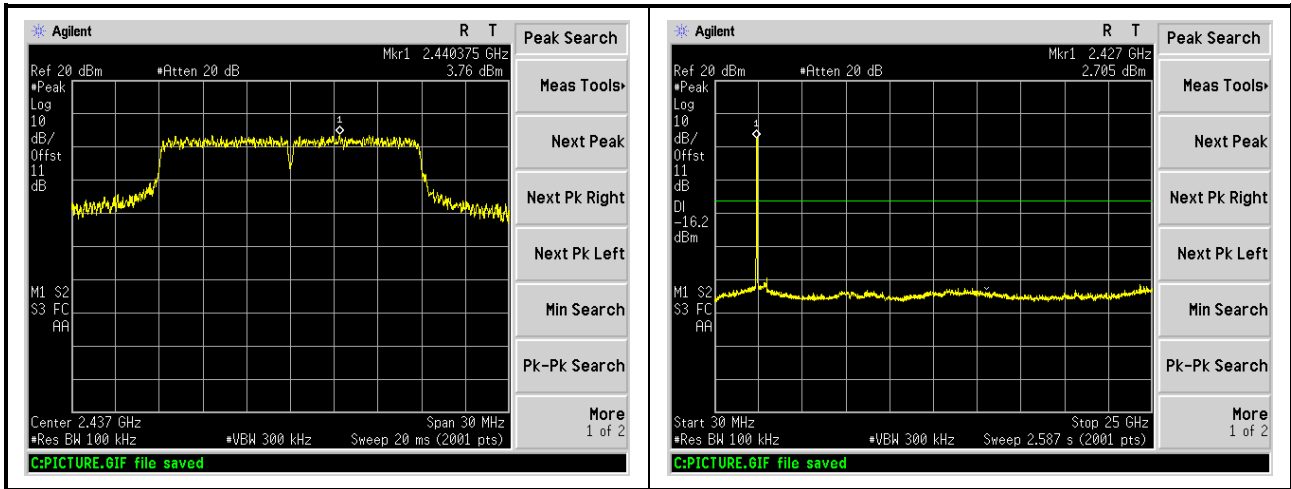

Mode 3: Transmit by 802.11n20 (2462MHz)

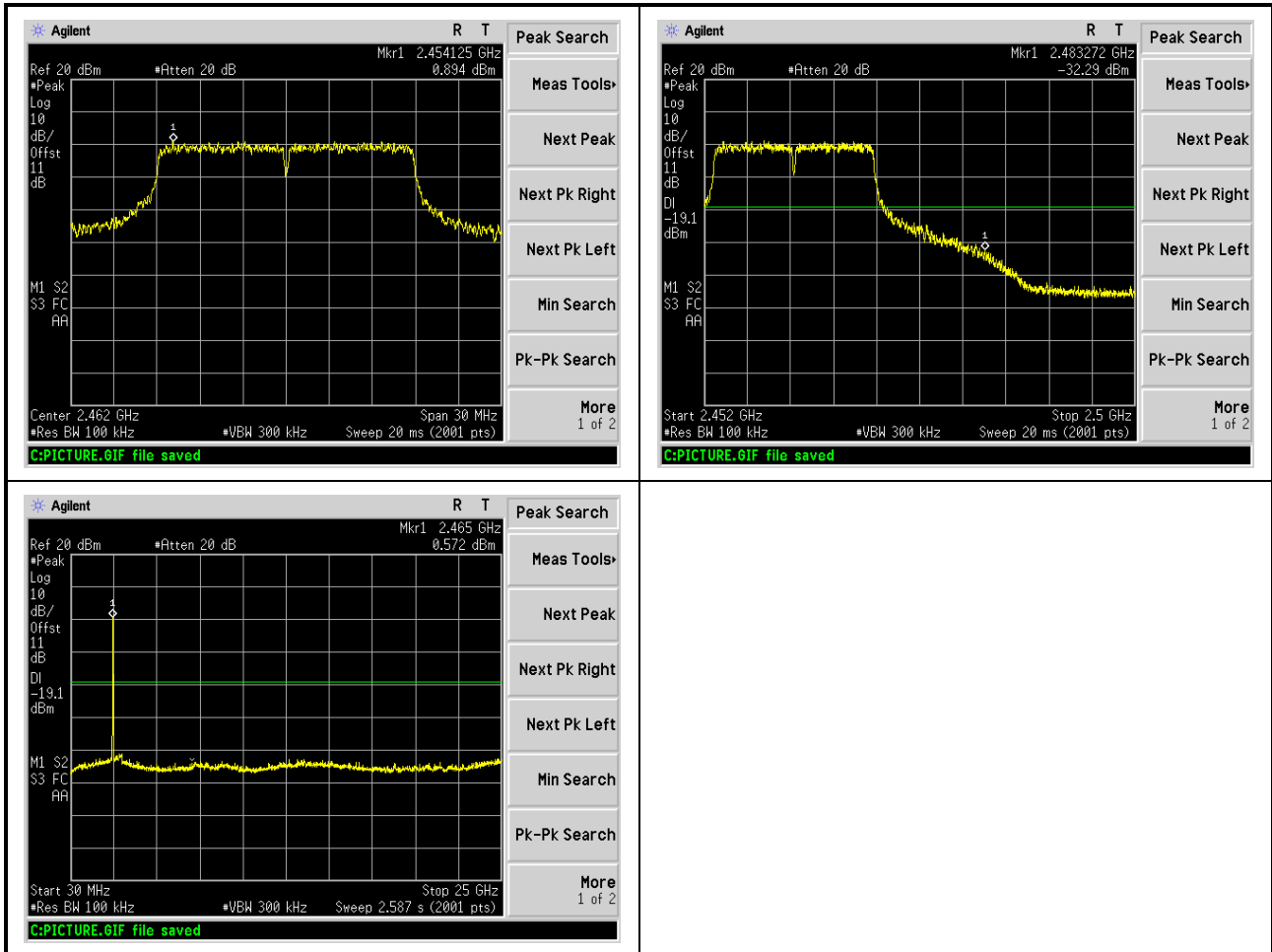



Mode 4: Transmit by 802.11n (40MHz) (2422MHz)

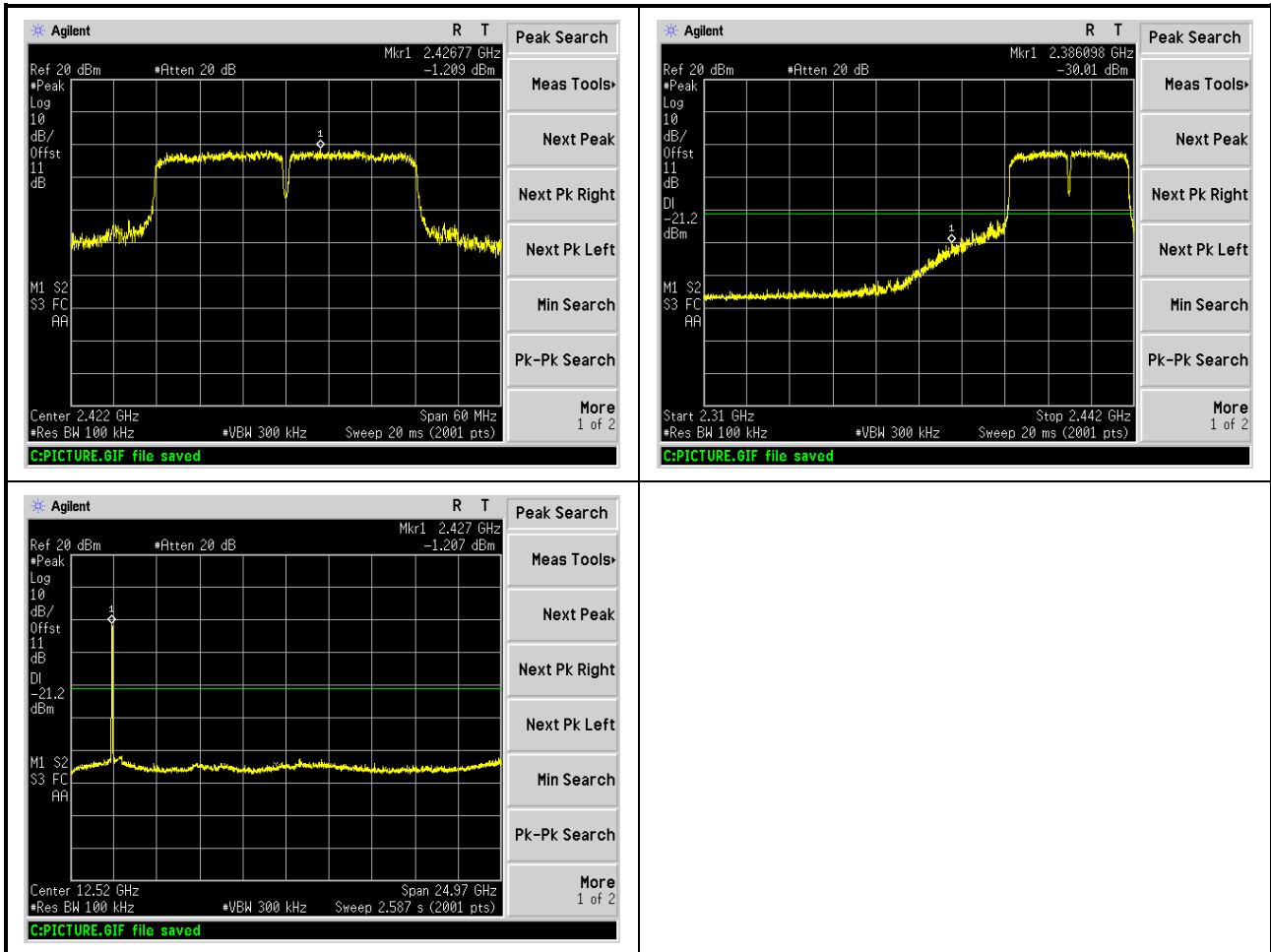



Mode 4: Transmit by 802.11n (40MHz) (2437MHz)

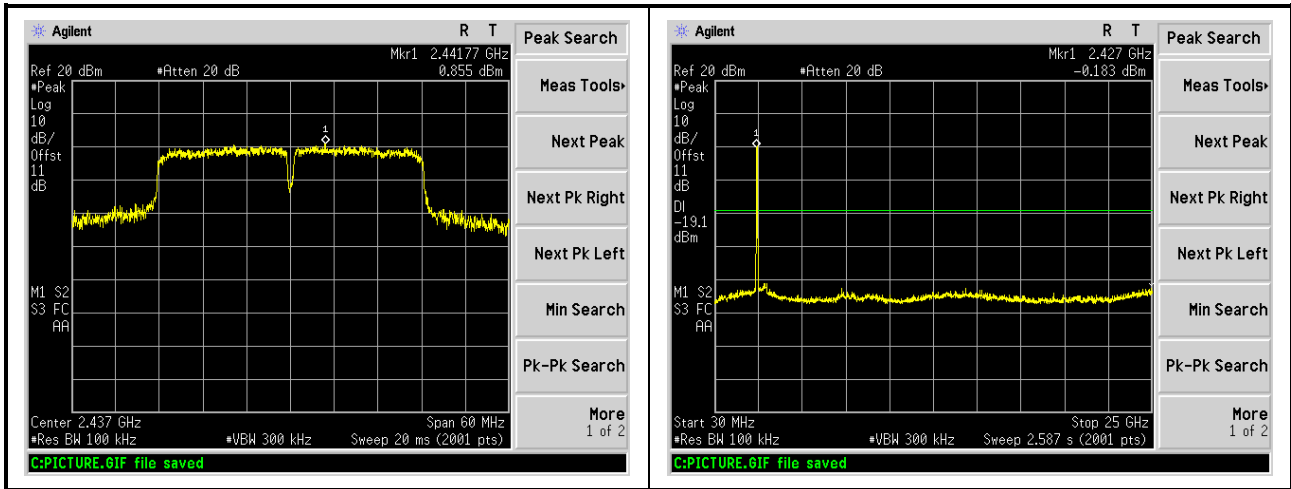

Mode 4: Transmit by 802.11n (40MHz) (2452MHz)

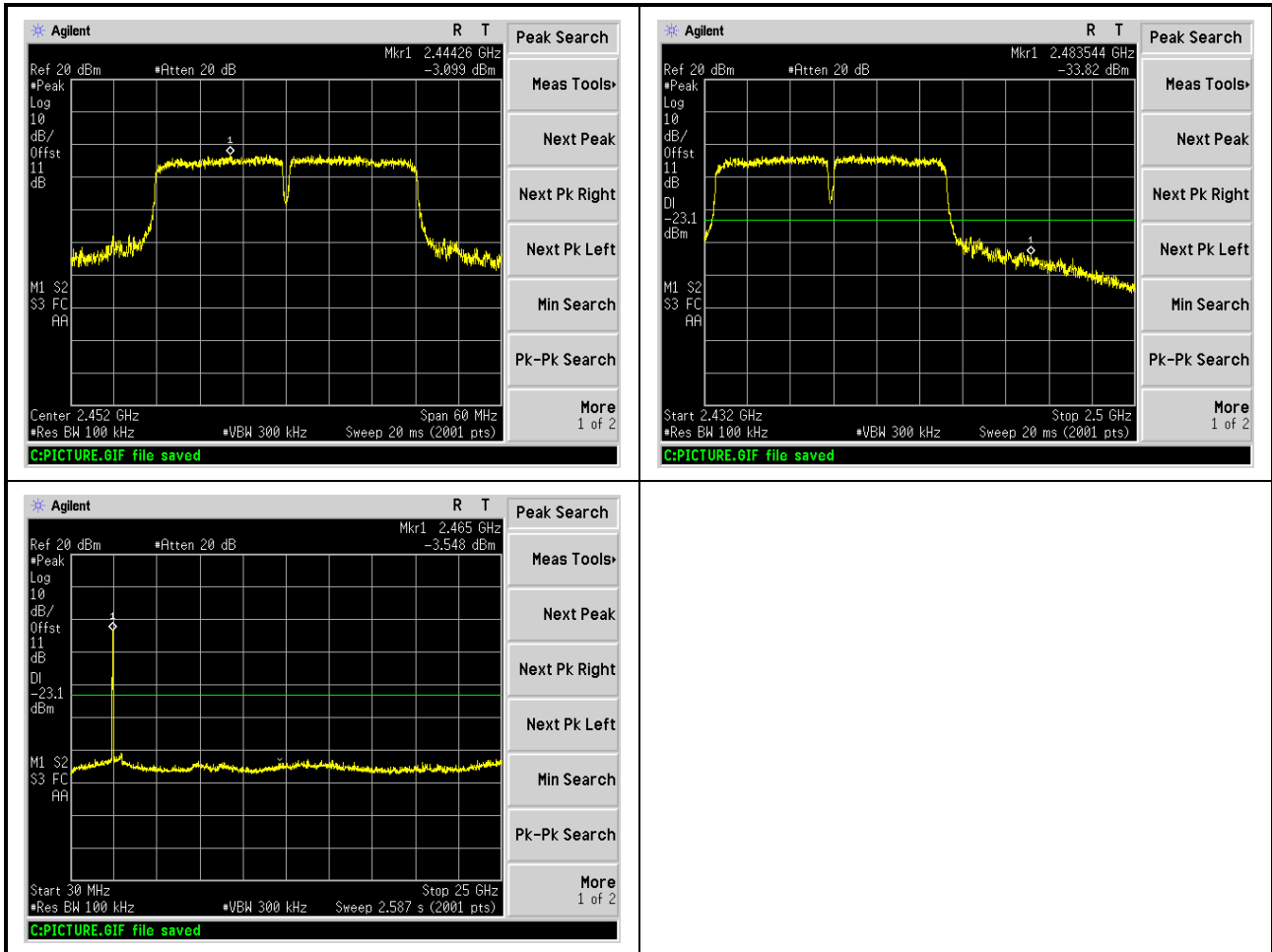



10. Restricted Bands of Operation

Only spurious emissions are permitted in any of the frequency bands listed below:

MHz	MHz	MHz	GHz
0.09000 – 0.11000	16.42000 – 16.42300	399.9 – 410.0	4.500 – 5.250
0.49500 – 0.505**	16.69475 – 16.69525	608.0 – 614.0	5.350 – 5.460
2.17350 – 2.19050	16.80425 – 16.80475	960.0 – 1240.0	7.250 – 7.750
4.12500 – 4.12800	25.50000 – 25.67000	1300.0 – 1427.0	8.025 – 8.500
4.17725 – 4.17775	37.50000 – 38.25000	1435.0 – 1626.5	9.000 – 9.200
4.20725 – 4.20775	73.00000 – 74.60000	1645.5 – 1646.5	9.300 – 9.500
6.21500 – 6.21800	74.80000 – 75.20000	1660.0 – 1710.0	10.600 – 12.700
6.26775 – 6.26825	108.00000 – 121.94000	1718.8 – 1722.2	13.250 – 13.400
6.31175 – 6.31225	123.00000 – 138.00000	2200.0 – 2300.0	14.470 – 14.500
8.29100 – 8.29400	149.90000 – 150.05000	2310.0 – 2390.0	15.350 – 16.200
8.36200 – 8.36600	156.52475 – 156.52525	2483.5 – 2500.0	17.700 – 21.400
8.37625 – 8.38675	156.70000 – 156.90000	2655.0 – 2900.0	22.010 – 23.120
8.41425 – 8.41475	162.01250 – 167.17000	3260.0 – 3267.0	23.600 – 24.000
12.29000 – 12.29300	167.72000 – 173.20000	3332.0 – 3339.0	31.200 – 31.800
12.51975 – 12.52025	240.00000 – 285.00000	3345.8 – 3358.0	36.430 – 36.500
12.57675 – 12.57725	322.00000 – 335.40000	3600.0 – 4400.0	Above 38.6
13.36000 – 13.41000			

** : Until February 1, 1999, this restricted band shall be 0.490-0.510 MHz

10.1 Labeling Requirement

The device shall bear the following statement in a conspicuous location on the device:

This device complies with part 15 of the FCC Rules. Operation is subject to the following two conditions:

(1) This device may not cause harmful interference, and (2) this device must accept any interference received, including interference that may cause undesired operation.