



Product:Amcrest 1080P Wi-Fi Video Doorbell

Model:AD110

Input:16-24V \sim ,50-60Hz,0.4A

P/N:1.0.01.15.11367



WiFi MAC: 9C:8E:CD:2A:D7:AD



S/N: Z0590AA1D0D15

FCC ID:ZZ2-Z05

IC:21923-Z05

MADE IN CHINA



REVISIONS					
REV	ZONE	MARK	DESCRIPTION	DATE	CHANGED

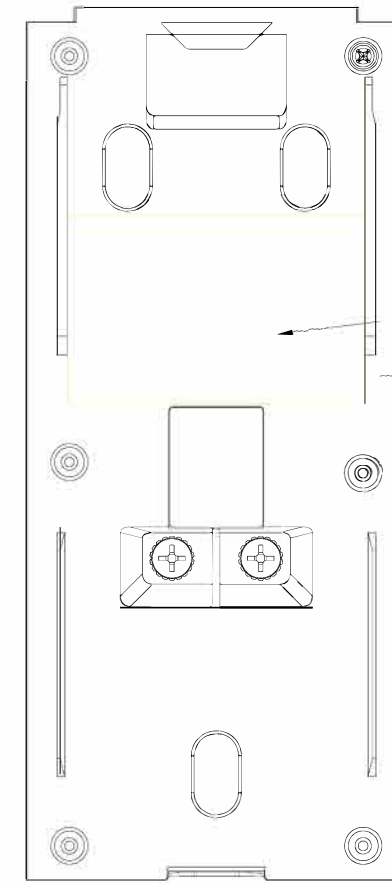
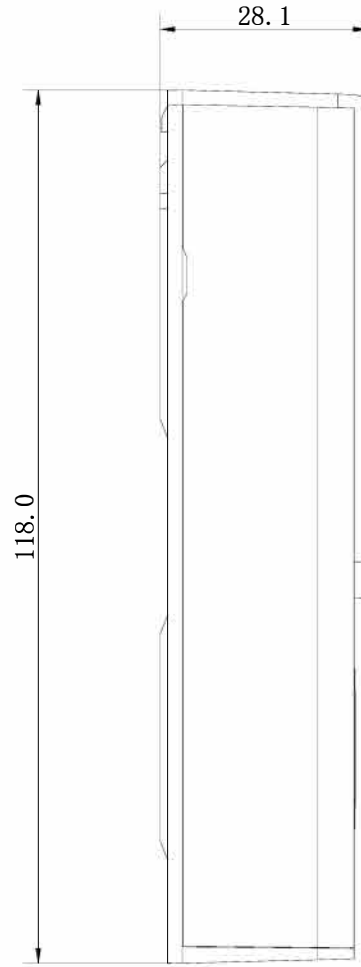
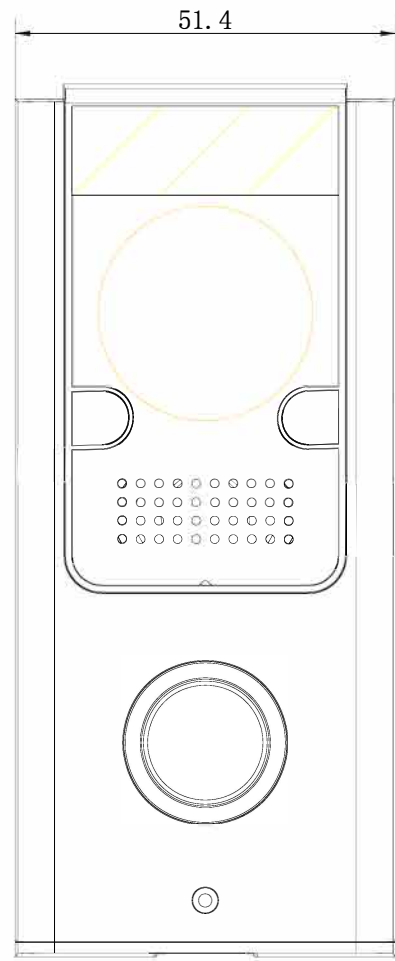

Label location

RELEASE LEVEL: &PROI_RELEASE
FILE NAME: 0-DH3-RD000330-0000

. X	±0.2			TITLE: ZAO17X-00-整机组件 UNIT'S: mm DWG NO.: 0-DH3-RD000330-0000 SCALE: 1:1 REV: B01 MASS(g): 228634.4 PART NO.: SHEET: 1 OF 1
. XX	±0.15			
. XXX	±0.05			
ANG		0.5	DRAW: DATE: CHKD: DATE: STAD: DATE: APPD: DATE:	

THESE DRAWINGS AND SPECIFICATION ARE THE PROPERTY OF ZHEJIANG DAHUA TECHNOLOGY Co., LTD. AND SHALL NOT BE REPRODUCED COPIED OR USED IN ANY MANNER WITHOUT THE PRIOR WRITTEN CONSENT OF ZHEJIANG DAHUA TECHNOLOGY Co., LTD.