

## FCC Part 22H/24E TEST REPORT

for

Mobile Phone

Model: WISE+

**FCC ID: ZYPWISE**

Prepared for: Nexpro International Limitada  
Guadalupe, Barrio Tournon, Frente Al Hotel Villas Oficinas Del Bufete  
Facio Y Canas, San Jose-Goicoechea, Costa Rica

Prepared by: Shenzhen TCT Testing Technology Co.,Ltd  
1F, Building 1, Yibaolai Industrial Park, Qiaotou Village,  
Fuyong Town, Baoan District, Shenzhen, Guangdong, China

TEL: +86-0755-27673339

FAX: +86-0755-27673332

Report Number: TCT130802044F2-2  
Date of Test: August 25, 2013-September 11, 2013  
Date of Report: September 11, 2013

Tested By Beryl Zhao  
Beryl Zhao

Reviewed By Jack Kang  
Jack Kang

*The results detailed in this test report relate only to the specific sample(s) tested. It is the Application's responsibility to ensure that all production units are manufactured with equivalent EMC characteristics. This report is not to be reproduced except in full, without written approval from TCT Testing Technology.*

**TABLE OF CONTENTS**

- 1. GENERAL INFORMATION .....3**
  - 1.1. Report information .....3
  - 1.2. Measurement Uncertainty .....3
- 2. PRODUCT DESCRIPTION .....4**
  - 2.1. EUT Description .....4
  - 2.2. Block Diagram of EUT Configuration.....5
  - 2.3. Configuration of Test Setup.....5
  - 2.4. Test Conditions .....5
- 3. TEST RESULTS SUMMARY .....6**
  - Note: WCDMA EMI testing was done in SIM 1 and SIM 1 Only Support WCDMA,.....6
  - GSM EMI testing was done in SIM 2 and SIM 2 Only Support GSM.....6
  - Modifications .....6
- 4. TEST EQUIPMENT USED .....7**
- 5. OUTPUT POWER .....8**
  - 5.1. Conducted Output Power .....8
  - 5.2. Radiated Output Power .....10
- 6. SPURIOUS EMISSION.....13**
  - 6.1. CONDUCTED SPURIOUS EMISSION .....13
  - 6.2. Radiated Spurious Emission .....18
  - 6.3. MEASUREMENT RESULT .....19
- 7. MAINS CONDUCTED EMISSION.....22**
  - 7.1. MEASUREMENT METHOD .....22
  - 7.2. PROVISIONS APPLICABLE.....22
  - 7.3. MEASUREMENT RESULT .....23
- 8. FREQUENCY STABILITY .....25**
  - 8.1. Applicable Standard.....25
  - 8.2. Test Procedure .....25
  - 8.3. Measurement Result.....26
- 9. OCCUPIED BANDWIDTH .....28**
  - 9.1. MEASUREMENT METHOD .....28
  - 9.2. PROVISIONS APPLICABLE.....28
  - 9.3. MEASUREMENT RESULT .....28
- 10. EMISSION BANDWIDTH .....31**
  - 10.1. MEASUREMENT METHOD .....31
  - 10.2. PROVISIONS APPLICABLE.....31
  - 10.3. MEASUREMENT RESULT .....31
- 11. BAND EDGE .....34**
  - 11.1. MEASUREMENT METHOD .....34
  - 11.2. PROVISIONS APPLICABLE.....34
  - 11.3. MEASUREMENT RESULT .....34

## 1. GENERAL INFORMATION

### 1.1. Report information

1.1.1. This report is not a certificate of quality; it only applies to the sample of the specific product/equipment given at the time of its testing. The results are not used to indicate or imply that they are application to the similar items. In addition, such results must not be used to indicate or imply that TCT approves recommends or endorses the manufacture, supplier or use of such product/equipment, or that TCT in any way guarantees the later performance of the product/equipment.

1.1.2. The sample/s mentioned in this report is/are supplied by Applicant, TCT therefore assumes no responsibility for the accuracy of information on the brand name, model number, origin of manufacture or any information supplied.

Additional copies of the report are available to the Applicant at an additional fee. No third part can obtain a copy of this report through Nexpro International Limitada, unless the applicant has authorized Nexpro International Limitada in writing to do so.

Test Facility -

The test site used to collect the radiated data is located on the address of Compliance Certification Services (Shenzhen) Inc.

(FCC Registered Test Site Number: 441872) on

No.10-1 Mingkeda Logistics Park. No. 18 Huanguan South RD. Guanlan Town, Baoan District Shenzhen, China.

The Test Site is constructed and calibrated to meet the FCC requirements.

### 1.2. Measurement Uncertainty

The reported uncertainty of measurement  $y \pm U$ , where expended uncertainty  $U$  is based on a standard uncertainty multiplied by a coverage factor of  $k=2$ , providing a level of confidence of approximately 95 %.

No.	Item	Uncertainty
1	Conducted Emission Test	$\pm 1.38\text{dB}$
2	RF power, conducted	$\pm 0.16\text{dB}$
3	Spurious emissions, conducted	$\pm 0.21\text{dB}$
4	All emissions, radiated (<1G)	$\pm 4.68\text{dB}$
5	All emissions, radiated (>1G)	$\pm 4.89\text{dB}$
6	Temperature	$\pm 0.5^\circ\text{C}$
7	Humidity	$\pm 2\%$

## 2. PRODUCT DESCRIPTION

### 2.1. EUT Description

Description	: Mobile Phone
Applicant	: Nexpro International Limitada
Model Number	: WISE+
Trade Name	: N/A
Modulation	GMSK(GSM/GPRS) QPSK (WCDMA)
Frequency Bands	: GSM 850: 824- 849MHz PCS 1900: 1850-1910MHz UMTS BAND V: 824-849MHz
Antenna gain	: 0dBi for GSM850 and UMTS BAND V 0dBi for PCS1900
Antenna Type	: Integral Antenna
Power Supply	DC 3.7V Battery or DC 5V from Adapter Adapter information: Model: TPA-595055UU INPUT: AC 100-240V 50/60Hz OUTPUT: DC 5V, 550mA
Battery information	: Model: HQ-E56 Voltage: 3.7V/1500mAh
Hardware version	: N/A
Software version	: N/A

**2.2. Block Diagram of EUT Configuration**

**Radiated output power**

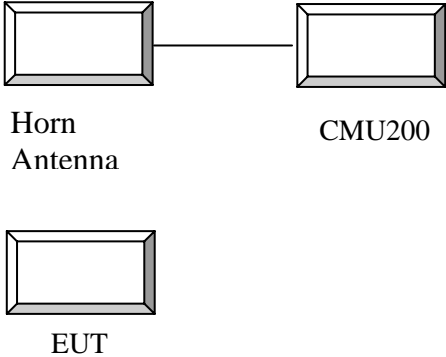

**Conducted output power**

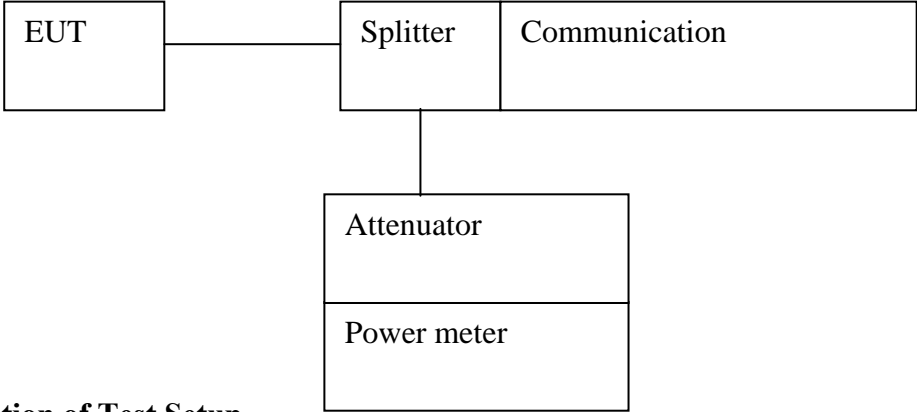

**2.3. Configuration of Test Setup**

EUT Orthogonal Axis:  
X - denotes Laid on Table; Y - denotes Vertical Stand; Z - denotes Side Stand

**2.4. Test Conditions**

Temperature: 23~25°C  
Relative Humidity: 55~63 %

**3. TEST RESULTS SUMMARY**

**FCC PART 22H & FCC PART 24E**

FCC Rules	Description of Test	Result
§1.1307, §2.1093	RF Exposure (SAR)	Compliance (Please refer to SAR report)
§2.1046; § 22.913 (a); § 24.232 (c)	RF Output Power	Compliance
§ 2.1047	Modulation Characteristics	Not Applicable
§ 2.1049; § 22.905 § 22.917; § 24.238	Occupied Bandwidth	Compliance
§ 2.1051, § 22.917 (a); § 24.238 (a)	Spurious Emissions at Antenna Terminal	Compliance
§ 2.1053 § 22.917 (a); § 24.238 (a)	Field Strength of Spurious Radiation	Compliance
§ 22.917 (a); § 24.238 (a)	Out of band emission, Band Edge	Compliance
§ 2.1055 § 22.355; § 24.235	Frequency stability vs. temperature Frequency stability vs. voltage	Compliance

Note: WCDMA EMI testing was done in SIM 1 and SIM 1 Only Support WCDMA,  
GSM EMI testing was done in SIM 2 and SIM 2 Only Support GSM

**Modifications**

No modification was made.

#### 4. TEST EQUIPMENT USED

EQUIPMENT/FACILITIES	MANUFACTURER	MODEL	SERIAL NO.	DATE OF CAL.	CAL. INTERVAL
3m Semi-Anechoic Chamber	ZhongYu Electron	9.2(L)*6.2(W)* 6.4(H)	GTS250	Mar. 30 2013	1 Year
Control Room	ZhongYu Electron	6.2(L)*2.5(W)* 2.4(H)	GTS251	N/A	N/A
EMI Test Receiver	Rohde & Schwarz	ESU26	GTS203	Jul. 04 2013	1 Year
BiConiLog Antenna	Schwarzbeck Mess-Elektronik	VULB9163	GTS214	Feb. 25 2013	1 Year
Double -ridged waveguide horn	SCHWARZBECK MESS-ELEKTRO NIK	9120D-829	GTS208	June 30 2013	1 Year
Horn Antenna	ETS-LINDGREN	3160	GTS217	Mar. 30 2013	1 Year
EMI Test Software	AUDIX	E3	N/A	N/A	N/A
Cable	Resenberger	N/A	NO.1	Apr. 6, 2013	1 Year
Cable	SCHWARZBECK	N/A	NO.2	Apr. 6, 2013	1 Year
Cable	SCHWARZBECK	N/A	NO.3	Apr. 6, 2013	1 Year
Amplifier(100kHz-3GHz)	HP	8347A	GTS204	Jul. 04 2013	1 Year
Amplifier(2GHz-20GHz)	HP	8349B	GTS206	Jul. 04 2013	1 Year
Amplifier (18-26GHz)	R&S	AFS33-18002 650-30-8P-44	GTS218	June 30 2013	1 Year
Band filter	Amindeon	82346	GTS219	Mar. 31 2013	1 Year
Active Loop Antenna	Beijing Daze	ZN30900A	GTS215	Mar. 31 2013	1 Year
Power Meter	R&S	NRVS	GTS216	Apr. 6, 2013	1 Year
Power Sensor	R&S	NRV-Z33	GTS220	Apr. 6, 2013	1 Year
Shielding Room	ZhongYu Electron	7.0(L)x3.0(W)x3.0(H)	GTS264	Sep. 08 2013	1 Year
Universal radio communication tester	R&S	CMU200	GTS235	May 11 2013	1 Year
Signal Generator	R&S	SML03	GTS236	May 11 2013	1 Year
Temp. Humidity/Barometer	Oregon Scientific	BA-888	GTS248	May 11 2013	1 Year
D.C. Power Supply	Instek	PS-3030	GTS232	N/A	N/A
Splitter	Agilent	11636B	GTS237	May 11 2013	1 Year
EMI Test Receiver	R&S	ESCS30	GTS223	Jul. 04 2013	1 Year
10dB Pulse Limita	R&S	N/A	GTS224	Jul. 04 2013	1 Year
Coaxial Switch	ANRITSU CORP	MP59B	GTS225	Jul. 04 2013	1 Year
LISN	Schwarzbeck Mess-Elektronik	NSLK 8127	GTS226	Jul. 04 2013	1 Year
Coaxial Cable	SCHWARZBECK	N/A	NO.4	Apr. 6, 2013	1 Year
EMI Test Software	AUDIX	E3	N/A	N/A	N/A
Spectrum analyzer	agilent	E4440A	GTS251	N/A	N/A

## 5. OUTPUT POWER

### 5.1. Conducted Output Power

#### 5.1.1.MEASUREMENT METHOD

The EUT was setup for the max output power with pseudo random data modulation. The EUT was directly connected to the power meter. The measurements were performed on all modes(GPRS850, GPRS1900, HSDPA band V ) at 3 typical channels(the Top Channel, the Middle Channel and the Bottom Channel) for each band.

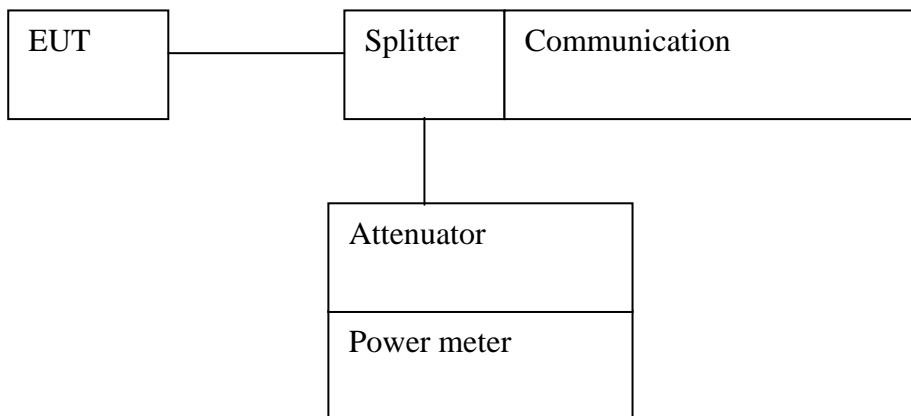

#### Power Limits

According to FCC §2.1046 and §22.913 (a), the ERP of mobile transmitters and auxiliary test transmitters must not exceed 7 watts.

According to FCC §2.1046 and §24.232 (C), mobile and portable stations are limited to 2 watts EIRP and the equipment must employ a means for limiting power to the minimum necessary for successful communications.



## 5.1.2.MEASUREMENT RESULT

## GSM /GPRS:

Band	Channel No.	Test Result PK Power(dBm)								
		GSM	GPRS 1 TX Slot	GPRS 2 TX Slot	GPRS 3 TX Slot	GPRS 4 TX Slot	EDGE 1 TX Slot	EDGE 2 TX Slot	EDGE 3 TX Slot	EDGE 4 TX Slot
Cellular	128	31.96	31.94	30.12	28.69	27.01	27.13	25.39	23.37	22.25
	190	32.41	32.39	30.57	28.53	27.1	26.85	26.11	23.45	22.25
	251	32.35	32.33	30.51	28.42	27.22	26.96	25.34	23.47	22.05
PCS	512	30.42	30.4	26.53	24.15	23.41	25.57	24.32	22.29	20.86
	661	30.63	30.61	26.18	24.3	23.17	25.46	24.27	22.43	20.49
	810	30.85	30.83	26.43	24.26	23.15	25.43	24.09	21.87	20.39

Mode	3GPP Sub test	WCDMA BAND V			WCDMA BAND II		
		Low Channel (Ave. Power)	Middle Channel (Ave. Power)	High Channel (Ave. Power)	Low Channel (Ave. Power)	Middle Channel (Ave. Power)	High Channel (Ave. Power)
Rel 99	1	22.32	22.43	22.53	21.85	21.8	21.74
Rel 6 HSDPA	1	22.13	22.38	22.19	21.16	21.08	21.13
	2	22.06	22.26	21.75	21.1	21.14	21.16
	3	21.35	22.01	21.39	21.3	21.2	21.19
	4	21.26	21.33	21.08	20.63	20.52	20.47
Rel 6 HSUPA	1	21.86	21.68	21.69	21.56	21.84	21.93
	2	20.39	20.09	20.49	20.31	20.72	20.83
	3	20.74	20.56	20.62	20.57	20.68	21.1
	4	20.47	20.37	20.54	20.24	20.23	20.26
	5	21.76	21.4	21.43	21.63	21.8	21.75

**5.2. Radiated Output Power**

**5.2.1. MEASUREMENT METHOD**

ANSI/TIA 603-D section 2.2.17

**Test SET-UP (Block Diagram of Configuration)**

(A) Radiated Emission Test Set-Up, Frequency Below 1000MHz

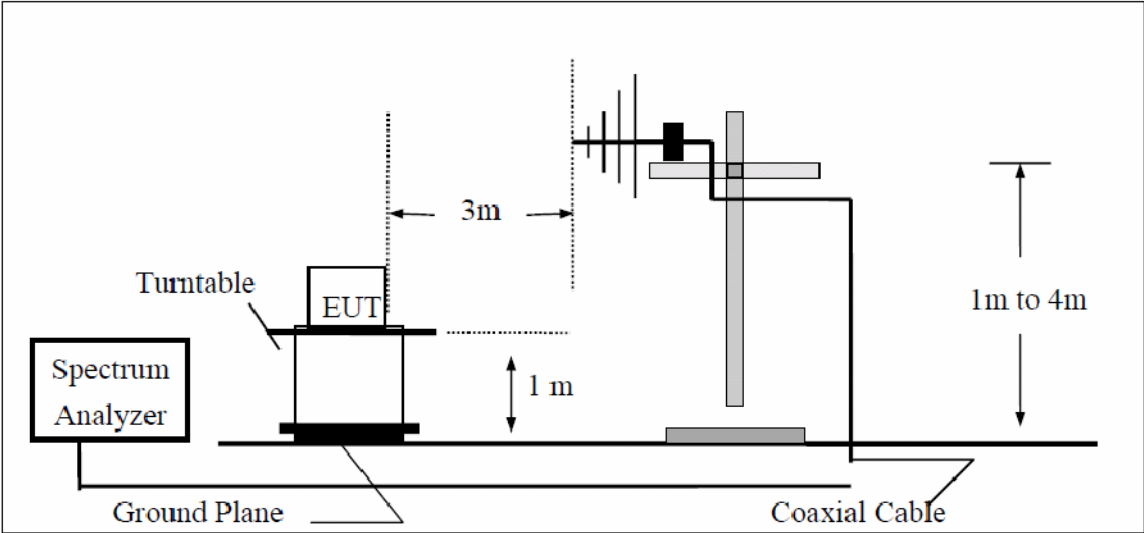

(B) Radiated Emission Test Set-Up Frequency Over 1 GHz

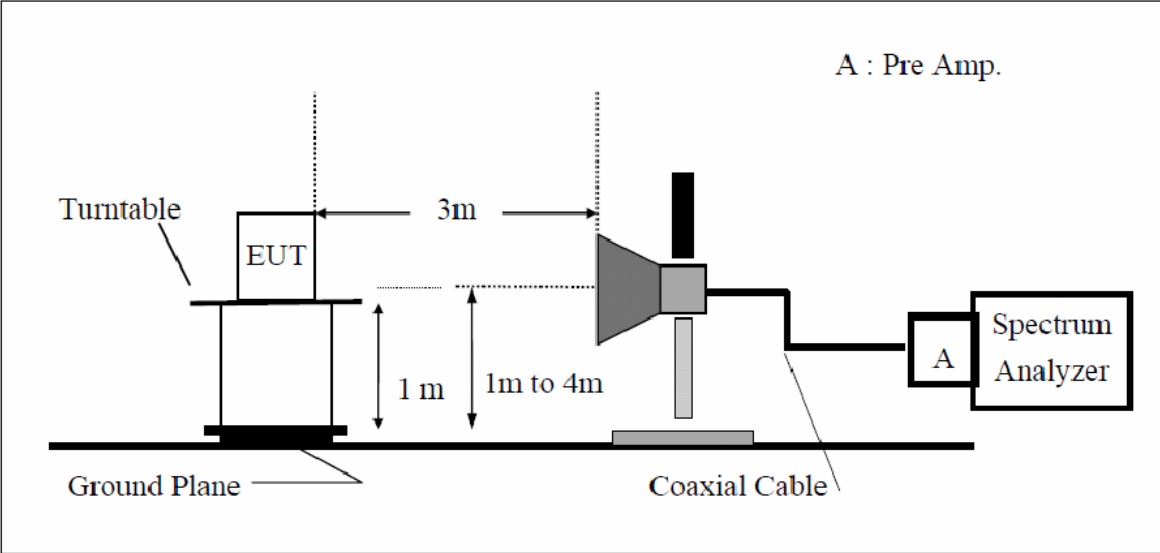

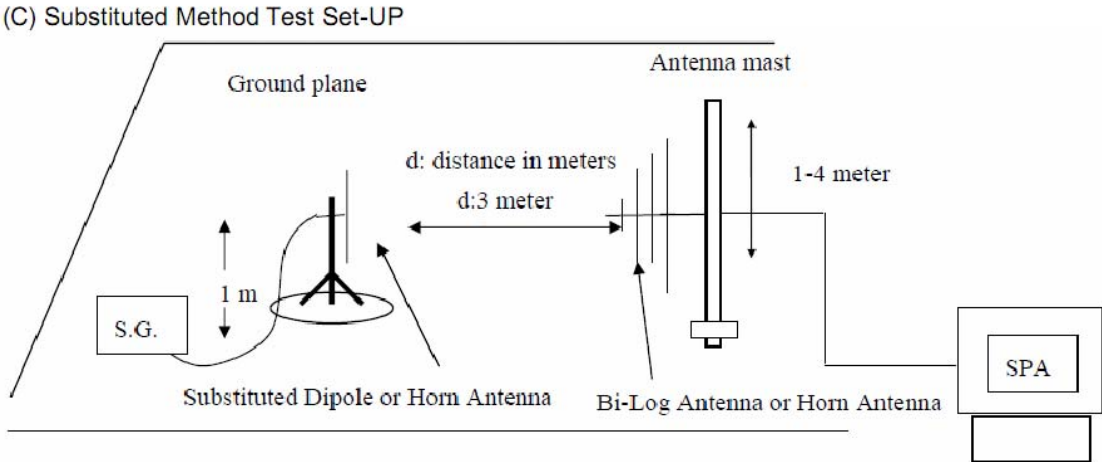

**Measurement Procedure**

The EUT was placed on an non-conductive turntable using a non-conductive support. The radiated emission at the fundamental frequency was measured at 3 m with a test antenna and EMI spectrum analyzer.

During the measurement, the EUT was communication with the station. The highest emission was recorded with the rotation of the turntable and the lowering of the test antenna from 4m to 1m. The reading was recorded and the field strength (E in dBuV/m) was calculated.

ERP in frequency band 824.2 –848.80.8MHz were measured using a substitution method. The EUT was replaced by dipole antenna connected, the S.G. output was recorded and ERP was calculated as follows:

EIRP in frequency band 1850.2 –1909.8MHz were measured using a substitution method. The EUT was replaced by or horn antenna connected, the S.G. output was recorded and EIRP was calculated as follows:

$$ERP = S.G. \text{ output (dBm) + Antenna Gain (dBd) – Cable Loss (dB)}$$

$$EIRP = S.G. \text{ output (dBm) + Antenna Gain (dBi) – Cable Loss (dB)}$$

**5.2.2.PROVISIONS APPLICABLE**

This is the test for the maximum radiated power from the EUT. Rule Part 24.232(b) specifies, “Mobile/portable stations are limited to 2 watts e.i.r.p. Peak power” and 24.232(c) specifies that "Peak transmit power must be measured over any interval of continuous transmission using instrumentation calibrated in terms of an rms-equivalent voltage.” Rule Part 22.913(a) specifies “Maximum ERP. The effective radiated power (ERP) of base transmitters and cellular repeaters must not exceed 500 Watts. The ERP of mobile transmitters and auxiliary test transmitters must not exceed 7 Watts.”

Mode	Nominal Peak Power
GSM 850	<=38.45 dBm (7W)
PCS 1900	<=33 dBm (2W)
UMTS BANDV	<=38.45 dBm (7W)

### 5.2.3.Measurement Result

#### ERP & EIRP

##### ERP for Cellular Band (Part 22H)

Frequency	Polar	S.A. Reading	S.G. Level	Antenna Gain	Cable Loss	Absolute Level	Limit
	H/V	dB $\mu$ V	dBm	dBd	dB	dBm	dBm
824.2	H	88.63	23.2	0.0	3.3	19.9	38.4
	V	105.20	37.6	0.0	3.3	34.3	38.4
836.6	H	88.54	22.5	0.0	3.3	19.2	38.4
	V	104.20	37.6	0.0	3.3	34.3	38.4
848.4	H	88.20	22.5	0.0	3.3	19.2	38.4
	V	102.36	36.7	0.0	3.3	33.4	38.4

##### EIRP for PCS Band (Part 24E)

Frequency	Polar	S.A. Reading	S.G. Level	Antenna Gain	Cable Loss	Absolute Level	Limit
	H/V	dB $\mu$ V	dBm	dB $i$	dB	dBm	dBm
1850.2	H	91.36	22.2	8.0	0.9	29.3	33.0
	V	90.25	20.4	8.0	0.9	27.5	33.0
1880.0	H	92.14	22.1	8.0	0.9	29.2	33.0
	V	91.07	20.8	8.0	0.9	27.9	33.0
1909.8	H	92.33	22.5	8.4	0.9	30.0	33.0
	V	90.52	20.4	8.4	0.9	27.9	33.0

##### ERP for WCDMA Band (Part 22H)

Frequency	Polar	S.A. Reading	S.G. Level	Antenna Gain	Cable Loss	Absolute Level	Limit
	H/V	dB $\mu$ V	dBm	dBd	dB	dBm	dBm
826.4	H	80.56	15.3	0.0	3.3	12.0	38.4
	V	93.54	27.2	0.0	3.3	23.9	38.4
836.6	H	81.74	15.6	0.0	3.3	12.3	38.4
	V	95.36	29.3	0.0	3.3	26.0	38.4
846.6	H	81.23	15.2	0.0	3.3	11.9	38.4
	V	95.30	28.6	0.0	3.3	25.3	38.4

##### EIRP for WCDMA Band (Part 24E)

Frequency	Polar	S.A. Reading	S.G. Level	Antenna Gain	Cable Loss	Absolute Level	Limit
	H/V	dB $\mu$ V	dBm	dB $i$	dB	dBm	dBm
1852.4	H	85.90	15.3	8.0	0.9	22.4	33.0
	V	84.30	22.1	8.0	0.9	29.2	33.0
1880	H	86.20	25.6	8.0	0.9	32.7	33.0
	V	84.42	21.4	8.0	0.9	28.5	33.0
1907.6	H	85.36	14.2	8.4	0.9	21.7	33.0
	V	84.53	21.9	8.4	0.9	29.4	33.0

## 6. SPURIOUS EMISSION

### 6.1. CONDUCTED SPURIOUS EMISSION

#### 6.1.1.measurement method

The following steps outline the procedure used to measure the conducted emissions from the EUT.

1. Determine frequency range for measurements: From CFR 2.1057 the spectrum should be investigated from the lowest radio frequency generated in the equipment up to at least the 10th harmonic of the carrier frequency. For the equipment of PCS1900 band, this equates to a frequency range of 30 MHz to 19.1 GHz, data taken from 30 MHz to 20 GHz. For GSM850, data taken from 30 MHz to 9 GHz.

2. Determine EUT transmit frequencies: the following typical channels were chosen to conducted emissions testing.

Typical Channels for testing of GSM850 band	
Channel	Frequency (MHz)
low	824.2
middle	836.6
high	848.8

Typical Channels for testing of PCS1900 band	
Channel	Frequency (MHz)
low	1850.2
middle	1880.0
high	1909.8

Typical Channels for testing of WCDMA 850 band	
Channel	Frequency (MHz)
low	826.4
middle	835.0
high	826.6

Typical Channels for testing of WCDMA 1900 band	
Channel	Frequency (MHz)
low	1852.4
middle	1880
high	1907.6

- Note: 1. Below 30MHZ no Spurious found and The GSM modes is the worst condition.  
2. As no emission found in standby or receive mode, no recording in this report.

### 6.1.2.Measurement Result

GSM 850 BAND  
Conducted Emission Transmitting Mode CH 190 30MHz-10GHz

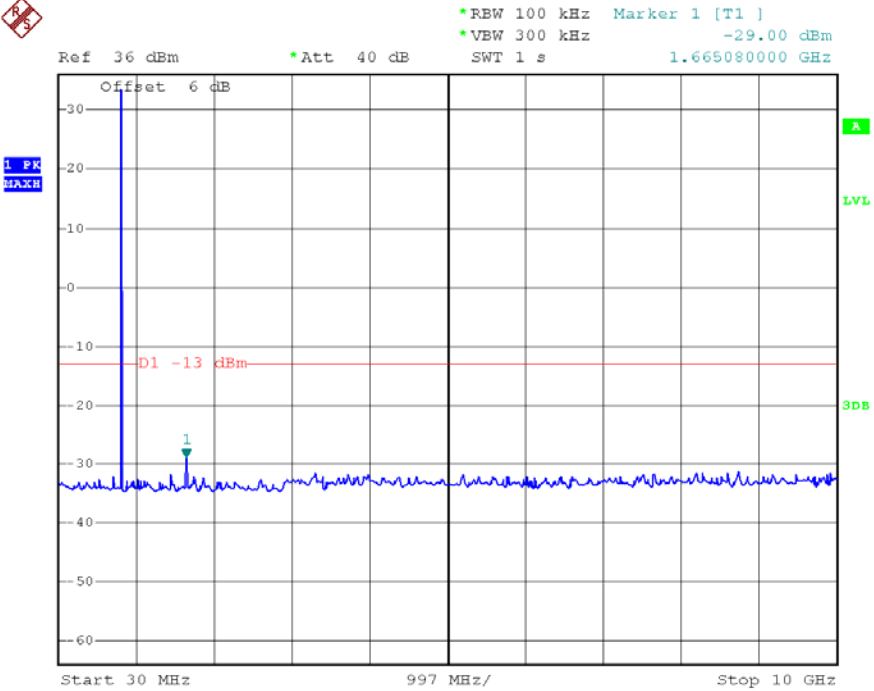

Date: 11.SEP.2013 15:23:12

# PCS 1900 BAND Conducted Emission Transmitting Mode CH 661 30MHz-10GHz

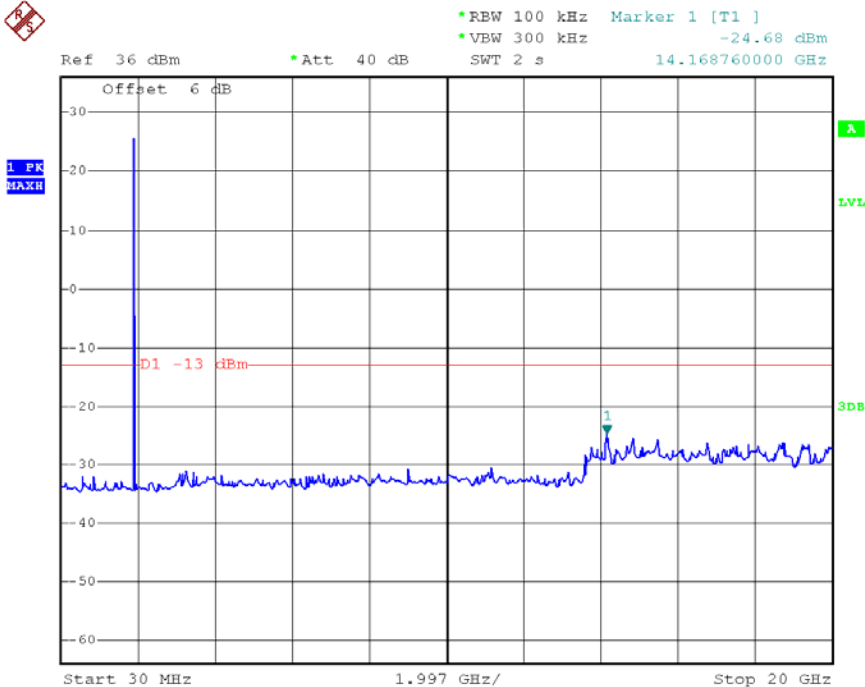

Date: 11.SEP.2013 15:45:52

### WCDMA 850 BAND Conducted Emission Transmitting Mode middle channel 30MHz-10GHz

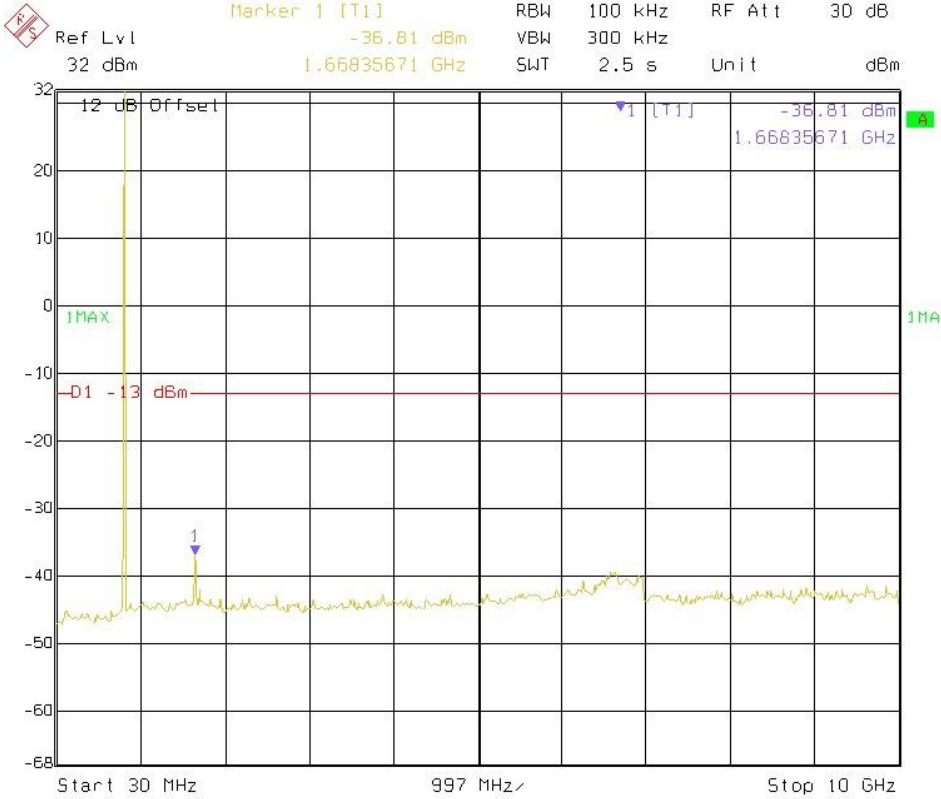



### WCDMA 1900 BAND Conducted Emission Transmitting Mode middle channel 30MHz-10GHz

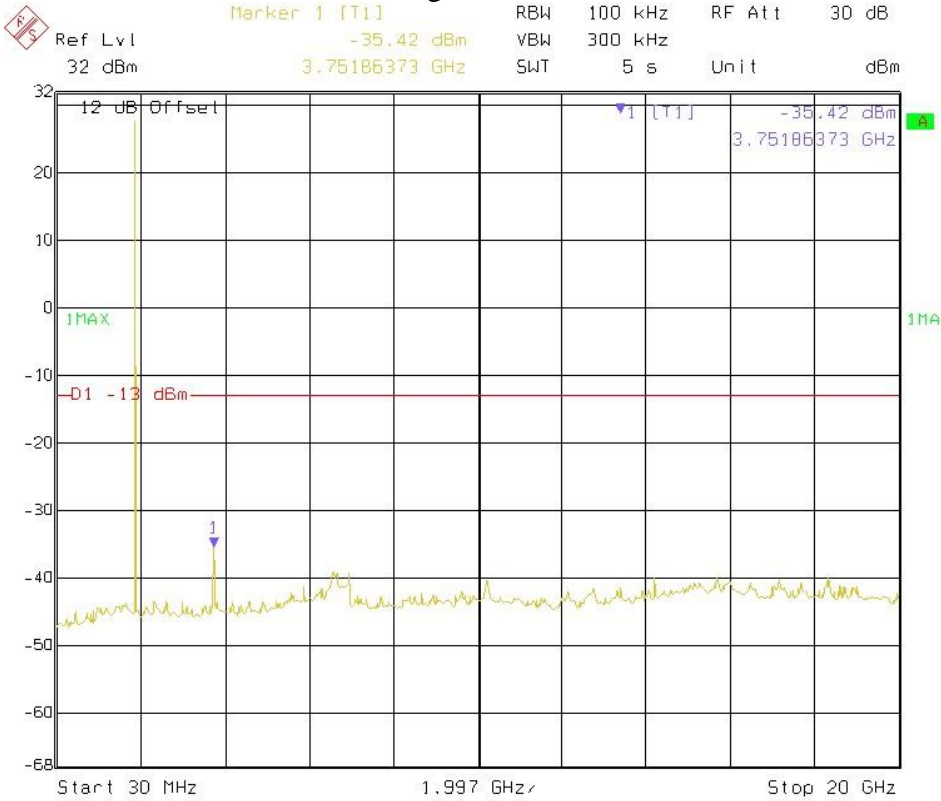

## 6.2. Radiated Spurious Emission

### 6.2.1. Measurement Method

The measurements procedures specified in TIA-603C-2004 were used for testing. The spectrum was scanned from 30 MHz to the 10th harmonic of the highest frequency generated within the equipment. The resolution bandwidth is set 1MHz as outlined in Part 24.238. The measurements were performed on all modes(GPRS850, GPRS1900, HSDPA band V) at 3 typical channels(the Top Channel, the Middle Channel and the Bottom Channel) for each band.

The procedure of radiated spurious emissions is as follows:

a) Pre-calibration With pre-calibration method, the Radiated Spurious Emissions(RSE) is calculated as,  $RSE = Rx(dBuV) + CL(dB) + SA(dB) + Gain(dBi) - 107(dBuV \text{ to } dBm)$  The SA is calibrated using following setup.

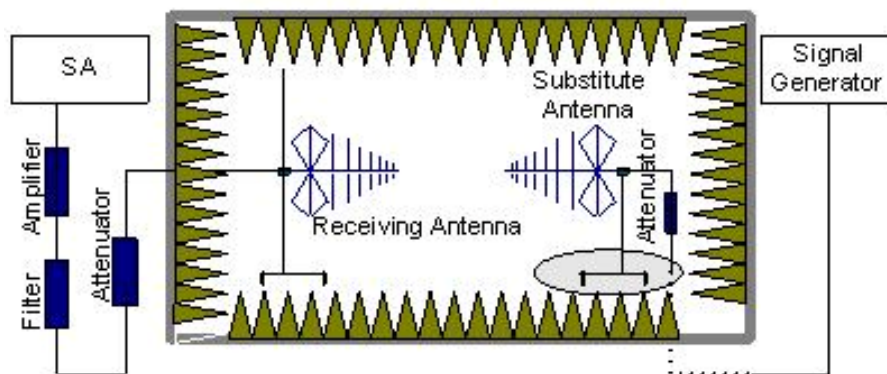

b) EUT was placed on a 0.8 meter high non-conductive stand at a 3 meter test distance from the receive antenna. A receiving antenna was placed on the antenna mast 3 meters from the test item for emission measurements. The height of receiving antenna is 0.8m. The test setup refers to figure below. Detected emissions were maximized at each frequency by rotating the test item and adjusting the receiving antenna polarization. The radiated emission measurements of all non-harmonic and harmonics of the transmit frequency through the 10th harmonic were measured with peak detector and 1MHz bandwidth.

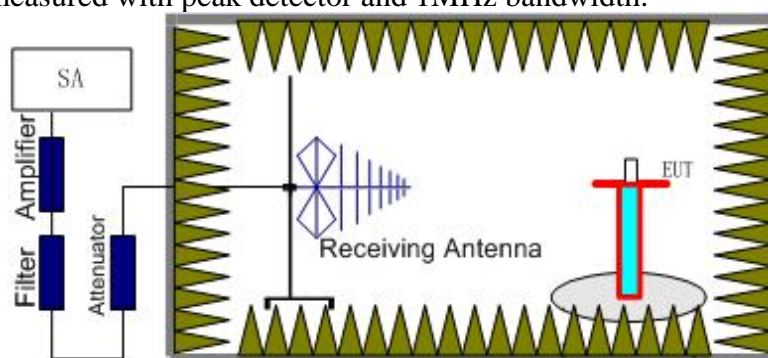

Radiated emissions measurements were made only at the upper, middle, and lower carrier frequencies of the PCS 1900 band (1850.2 MHz, 1880 MHz and 1909.8 MHz), GSM850 band (824.2MHz, 836.6MHz, 848.8MHz), UMTS band V(826.4MHz, 835.0MHz, 846.6MHz) . It was decided that measurements at these three carrier frequencies would be sufficient to demonstrate compliance with emissions limits because it was seen that all the significant spurs

occur well outside the band and no radiation was seen from a carrier in one block of any band into any of the other blocks.

The substitution method is used. Substitution values at each frequency are measured before and saved to the test software. A "reference path loss" is established and the ARpl is the attenuation of "reference path loss", and including the gain of receive antenna, the gain of the preamplifier, the cable loss and the air loss. The measurement results are obtained as described below:  $\text{Power} = \text{PMea} + \text{ARpl}$

### 6.2.2. Provisions Applicable

(a) On any frequency outside a licensee's frequency block (e.g. A, D, B, etc.) within the USPCS spectrum, the power of any emission shall be attenuated below the transmitter power (P, in Watts) by at least  $43 + 10 \log(P)$  dB. The specification that emissions shall be attenuated below the transmitter power (P) by at least  $43 + 10 \log(P)$  dB, translates in the relevant power range (1 to 0.001 W) to -13 dBm. At 1 W the specified minimum attenuation becomes 43 dB and relative to a 30 dBm (1 W) carrier becomes a limit of -13 dBm. At 0.001 W (0 dBm) the minimum attenuation is 13 dB, which again yields a limit of -13 dBm. In this way a translation of the specification from relative to absolute terms is carried out.

Note: only result the worst condition of each test mode:

### 6.3. MEASUREMENT RESULT

- GSM 850 data								
Frequency	Polar	S.A Reading	S.G. Level	Antenna Gain	Cable Loss	Absolute Level	Limit	Margin
MHz	H/V	dB $\mu$ V	dBm	dBd/dBi	dB	dBm	dBm	dB
Low Channel, fo = 824.2 MHz								
1648.400	H	44.23	-54.1	7.3	0.9	-47.7	-13.0	34.7
2472.600	H	43.26	-55.1	9.8	0.9	-46.2	-13.0	33.2
1648.400	V	39.63	-58.7	7.3	0.9	-52.3	-13.0	39.3
2472.600	V	42.18	-56.2	9.8	0.9	-47.2	-13.0	34.2
Middle Channel, fo = 836.6 MHz								
1673.200	H	42.31	-56.3	7.3	0.9	-49.9	-13.0	36.9
2509.800	H	43.58	-55.1	10.1	0.9	-45.8	-13.0	32.8
1673.200	V	42.97	-55.7	7.3	0.9	-49.2	-13.0	36.2
2509.800	V	44.75	-53.9	10.1	0.9	-44.6	-13.0	31.6
High Channel, fo = 848.8 MHz								
1696.800	H	41.63	-57.1	7.3	0.9	-50.7	-13.0	37.7
2545.200	H	42.36	-56.4	10.1	0.9	-47.2	-13.0	34.2
1696.800	V	40.52	-58.2	7.3	0.9	-51.8	-13.0	38.8
2545.200	V	42.10	-56.7	10.1	0.9	-47.4	-13.0	34.4

- GSM 1900 data								
Frequency	Polar	S.A. Reading	S.G. Level	Antenna Gain	Cable Loss	Absolute Level	Limit	Margin
MHz	H/V	dBμV	dBm	dBd/dBi	dB	dBm	dBm	dB
Low Channel, fo = 1850.2 MHz								
3700.400	H	54.36	-42.9	10.0	1.1	-34.0	-13.0	21.0
5550.600	H	44.25	-51.1	11.3	1.5	-41.2	-13.0	28.2
3700.400	V	53.62	-43.6	10.0	1.1	-34.7	-13.0	21.7
5550.600	V	47.58	-47.3	11.3	1.5	-37.5	-13.0	24.5
Middle Channel, fo = 1880.0 MHz								
3760.000	H	54.65	-41.4	10.0	1.1	-32.5	-13.0	19.5
5640.000	H	39.01	-55.1	11.2	1.5	-45.4	-13.0	32.4
3760.000	V	50.66	-45.4	10.0	1.1	-36.5	-13.0	23.5
5640.000	V	47.61	-46.5	11.2	1.5	-36.8	-13.0	23.8
High Channel, fo = 1909.8 MHz								
3819.600	H	52.67	-44.9	9.8	1.1	-36.1	-13.0	23.1
5729.400	H	48.36	-47.1	11.1	1.5	-37.4	-13.0	24.4
3819.600	V	55.74	-42.8	9.8	1.1	-34.0	-13.0	21.0
5729.400	V	51.49	-44.0	11.1	1.5	-34.3	-13.0	21.3

- WCDMA 850 data								
Frequency	Polar	S.A. Reading	S.G. Level	Antenna Gain	Cable Loss	Absolute Level	Limit	Margin
MHz	H/V	dBμV	dBm	dBd/dBi	dB	dBm	dBm	dB
Low Channel, fo = 826.4 MHz								
1652.800	H	46.85	-42.2	7.3	0.9	-35.8	-13.0	22.8
1652.800	V	43.68	-46.7	7.3	0.9	-40.2	-13.0	27.2
2479.200	H	34.36	-43.7	9.8	0.9	-34.8	-13.0	21.8
2479.200	V	36.24	-47.3	9.8	0.9	-38.4	-13.0	25.4
Middle Channel, fo = 836.6 MHz								
1673.200	H	45.63	-43.5	7.3	0.9	-37.0	-13.0	24.0
1673.200	V	42.69	-47.5	7.3	0.9	-41.0	-13.0	28.0
2509.800	H	33.44	-46.8	10.1	0.9	-37.6	-13.0	24.6
2509.800	V	35.72	-48.4	10.1	0.9	-39.2	-13.0	26.2
High Channel, fo = 846.6MHz								
1693.200	H	45.74	-43.3	7.3	0.9	-36.8	-13.0	23.8
1693.200	V	42.55	-47.6	7.3	0.9	-41.1	-13.0	28.1
2539.800	H	33.28	-48.2	10.1	0.9	-38.9	-13.0	25.9
2539.800	V	35.65	-48.9	10.1	0.9	-39.6	-13.0	26.6

- WCDMA 1900 data								
Frequency	Polar	S.A. Reading	S.G. Level	Antenna Gain	Cable Loss	Absolute Level	Limit	Margin
MHz	H/V	dB $\mu$ V	dBm	dBd/dBi	dB	dBm	dBm	dB
Low Channel, fo = 1852.4 MHz								
3704.800	H	56.32	-42.2	10.0	1.1	-33.3	-13.0	20.3
3704.800	V	42.56	-51.0	10.0	1.1	-42.1	-13.0	29.1
5557.200	H	52.14	-43.7	11.3	1.5	-33.9	-13.0	20.9
5557.200	V	40.22	-47.3	11.3	1.5	-37.5	-13.0	24.5
Middle Channel, fo = 1880.0 MHz								
3760.000	H	57.69	-39.2	10.0	1.1	-30.3	-13.0	17.3
5640.000	V	40.23	-55.4	11.2	1.5	-45.7	-13.0	32.7
3760.000	H	53.24	-45.5	10.0	1.1	-36.6	-13.0	23.6
5640.000	V	40.11	-55.3	11.2	1.5	-45.6	-13.0	32.6
High Channel, fo = 1907.6 MHz								
3815.200	H	60.37	-37.2	9.8	1.1	-28.4	-13.0	15.4
3815.200	V	42.87	-52.5	9.8	1.1	-43.8	-13.0	30.8
5722.800	H	54.23	-44.3	11.1	1.5	-34.7	-13.0	21.7
5722.800	V	44.85	-50.6	11.1	1.5	-41.0	-13.0	28.0

**Note:** Below 30MHz no Spurious found.  
in the part result the worst case GSM for Cellular ,PCS, and Rel 99 for WCDMA band V.

**7. MAINS CONDUCTED EMISSION**

**7.1. MEASUREMENT METHOD**

The measurement procedure specified in ANSI C63.4-2003 was used for testing. Conducted Emission was measured with travel charger.

**7.2. PROVISIONS APPLICABLE**

Frequency of Emission (MHz)	Conducted Limit(dBuV)	
	Quasi-Peak	Average
0.15 – 0.5	66 to 56 *	56 to 46 *
0.5 – 5	56	46
5 – 30	60	50

\*Decreases with the logarithm of the frequency.  
 \*The lower limit shall apply at the transition frequency.

**7.3. MEASUREMENT RESULT**

**Pass.**

Note: The GSM850(1 UP Slot) mode is the worst condition and the test result as following

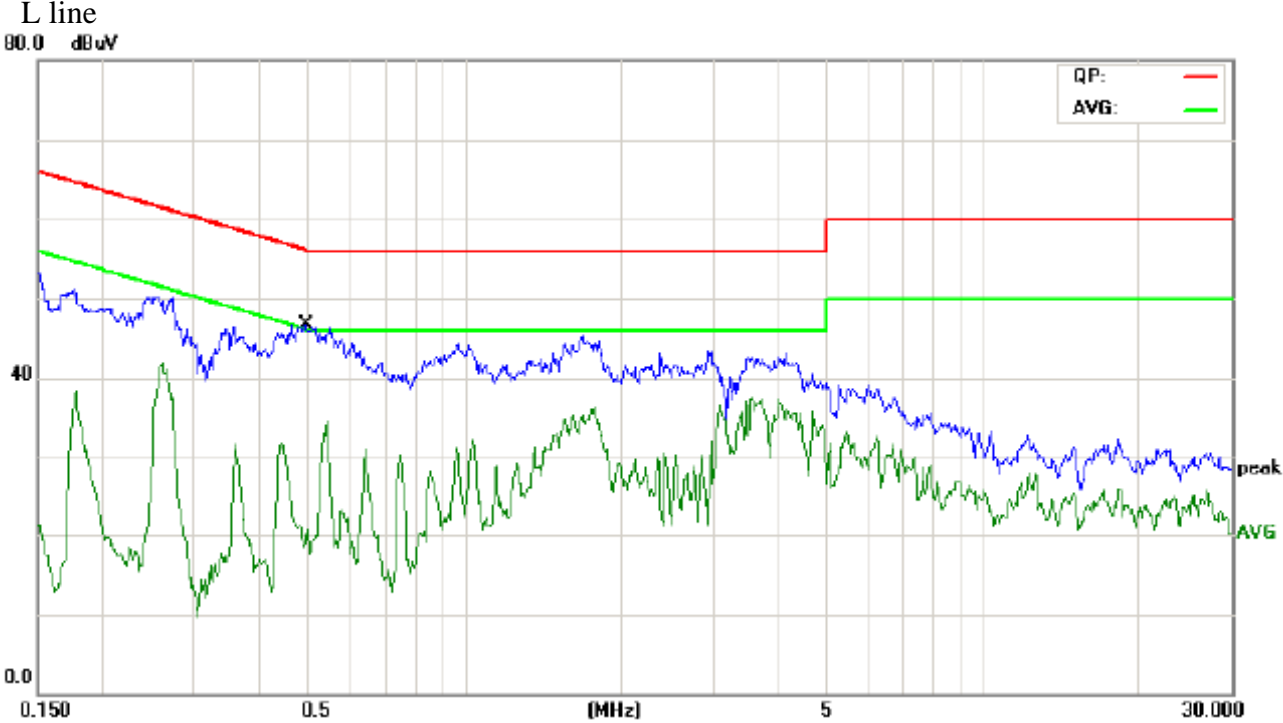

Frequency (MHz)	Reading(dBμV)				Limit (dBμV)	
	Live		Neutral		Quasi-peak	Average
	Quasi-peak	Average	Quasi-peak	Average		
0.4914	43.79	28.43	--	--	56.14	46.14

N line

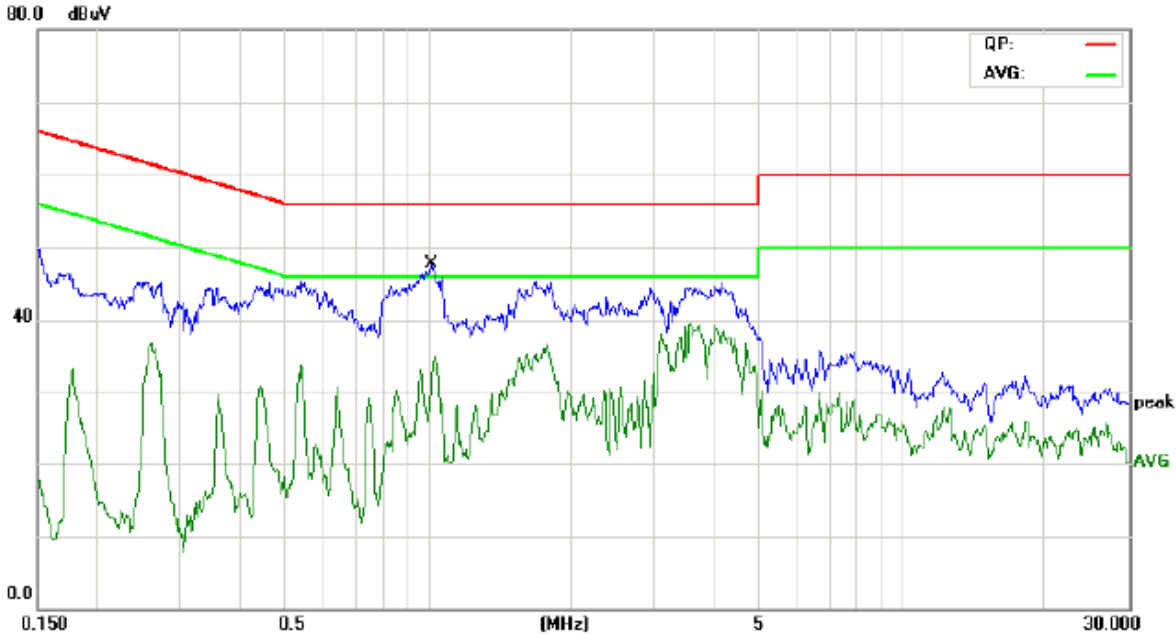

Frequency (MHz)	Reading(dBμV)				Limit (dBμV)	
	Live		Neutral		Quasi-peak	Average
	Quasi-peak	Average	Quasi-peak	Average		
1.0156	--	--	43.62	31.35	56.00	46.00



**8. FREQUENCY STABILITY**

**8.1. Applicable Standard**

FCC § 2.1055 (a), § 2.1055 (d), §22.355, §24.235

According to §22.355, the carrier frequency of each transmitter in the Public Mobile Services must be maintained within the tolerances given in Table below:

Frequency Tolerance for Transmitters in the Public Mobile Services

Frequency Range (MHz)	Base, fixed (ppm)	Mobile ≤ 3 watts (ppm)	Mobile ≤ 3 watts (ppm)
25 to 50	20.0	20.0	50.0
50 to 450	5.0	5.0	50.0
450 to 512	2.5	5.0	5.0
821 to 896	1.5	2.5	2.5
928 to 929.	5.0	N/A	N/A
929 to 960.	1.5	N/A	N/A
2110 to 2220	10.0	N/A	N/A

According to §24.235, the frequency stability shall be sufficient to ensure that the fundamental emissions stays within the authorized frequency block.

**8.2. Test Procedure**

Frequency Stability vs. Temperature: The equipment under test was connected to an external DC power supply and the RF output was connected to communication test set via feed-through attenuators. The EUT was placed inside the temperature chamber. The DC leads and RF output cable exited the chamber through an opening made for the purpose.

After the temperature stabilized for approximately 20 minutes, the frequency output was recorded from the communication test set.

Frequency Stability vs. Voltage: An external variable DC power supply was connected to the battery terminals of the equipment under test. The voltage was set to 115% of the nominal value and was then decreased until the transmitter light no longer illuminated; i.e., the battery end point. The output frequency was recorded for each battery voltage.

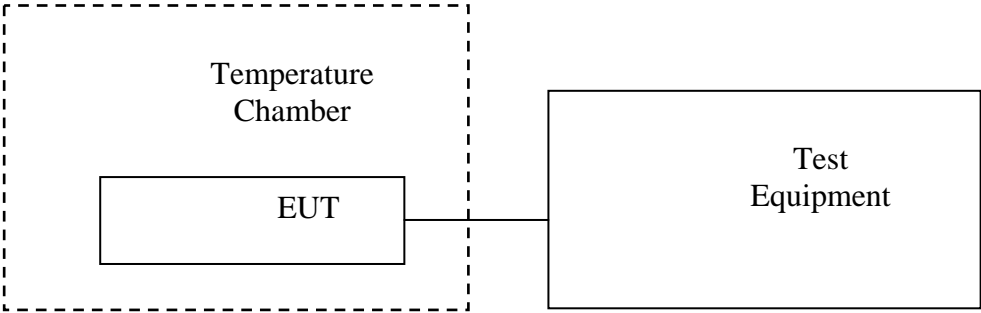

### 8.3. Measurement Result

#### Cellular Band (Part 22H)

- GSM 850 data				
Middle Channel, fo = 836.6 MHz				
Temperature	Voltage	Frequency Error	Frequency Error	Limit
°C	VDC	Hz	ppm	ppm
-30	3.7	-25	-0.030	2.5
-20	3.7	-22	-0.026	2.5
-10	3.7	-28	-0.033	2.5
0	3.7	-20	-0.024	2.5
10	3.7	-18	-0.022	2.5
20	3.7	-15	-0.018	2.5
30	3.7	-14	-0.017	2.5
40	3.7	-13	-0.016	2.5
50	3.7	-16	-0.019	2.5
25	3.5	-27	-0.032	2.5
25	4.2	-26	-0.031	2.5

#### PCS Band (Part 24E)

- GSM 1900 data				
Middle Channel, fo = 1880.0 MHz				
Temperature	Voltage	Frequency Error	Frequency Error	Result
°C	VDC	Hz	ppm	
-30	3.7	-11	-0.006	Pass
-20	3.7	-10	-0.005	Pass
-10	3.7	-7	-0.004	Pass
0	3.7	-3	-0.002	Pass
10	3.7	-5	-0.003	Pass
20	3.7	-6	-0.003	Pass
30	3.7	-6	-0.003	Pass
40	3.7	-7	-0.004	Pass
50	3.7	-12	-0.006	Pass
25	3.5	-13	-0.007	Pass
25	4.2	-12	-0.006	Pass

**- WCDMA Band V data****Middle Channel, fo = 836.6 MHz**

<b>Temperature</b>	<b>Voltage</b>	<b>Frequency Error</b>	<b>Frequency Error</b>	<b>Limit</b>
<b>°C</b>	<b>VDC</b>	<b>Hz</b>	<b>ppm</b>	<b>ppm</b>
-30	3.7	-11	-0.013	2.5
-20	3.7	-10	-0.012	2.5
-10	3.7	-7	-0.008	2.5
0	3.7	-3	-0.004	2.5
10	3.7	-5	-0.006	2.5
20	3.7	-8	-0.010	2.5
30	3.7	-6	-0.007	2.5
40	3.7	-4	-0.005	2.5
50	3.7	-9	-0.011	2.5
25	3.5	-12	-0.014	2.5
25	4.2	-13	-0.016	2.5

**-WCDMA Band II data****Middle Channel, fo = 1880.0 MHz**

<b>Temperature</b>	<b>Voltage</b>	<b>Frequency Error</b>	<b>Frequency Error</b>	<b>Result</b>
<b>°C</b>	<b>VDC</b>	<b>Hz</b>	<b>ppm</b>	
-30	3.7	-10	-0.005	Pass
-20	3.7	-9	-0.005	Pass
-10	3.7	-9	-0.005	Pass
0	3.7	-8	-0.004	Pass
10	3.7	-6	-0.003	Pass
20	3.7	-4	-0.002	Pass
30	3.7	-3	-0.002	Pass
40	3.7	-6	-0.003	Pass
50	3.7	-9	-0.005	Pass
25	3.5	-12	-0.006	Pass
25	4.2	-11	-0.006	Pass

## 9. OCCUPIED BANDWIDTH

### 9.1. MEASUREMENT METHOD

The test set up and general procedure is similar to conducted peak output power test. Only different for setting the measurement configuration of the measuring instrument of Spectrum Analyzer.

### 9.2. PROVISIONS APPLICABLE

The occupied bandwidth (99%) shall not exceed 300 KHz.

### 9.3. MEASUREMENT RESULT

<b>Occupied Bandwidth (99%) for GSM850 band</b>		
Mode	Frequency(MHz)	Occupied Bandwidth (99%)( kHz)
Middle Channel	836.6	242.00

<b>Occupied Bandwidth (99%) for PCS1900 band</b>		
Mode	Frequency(MHz)	Occupied Bandwidth (99%)( kHz)
Middle Channel	1880.0	242.00

<b>Occupied Bandwidth (99%) for WCDMA 850 band</b>		
Mode	Frequency(MHz)	Occupied Bandwidth (99%)( MHz)
Middle Channel	836.6	4.19

<b>Occupied Bandwidth (99%) for WCDMA 1900 band</b>		
Mode	Frequency(MHz)	Occupied Bandwidth (99%)( MHz)
Middle Channel	836.6	4.19

Note: The middle channel, which is the worst case, is reported only.

### GSM850 band middle Channel

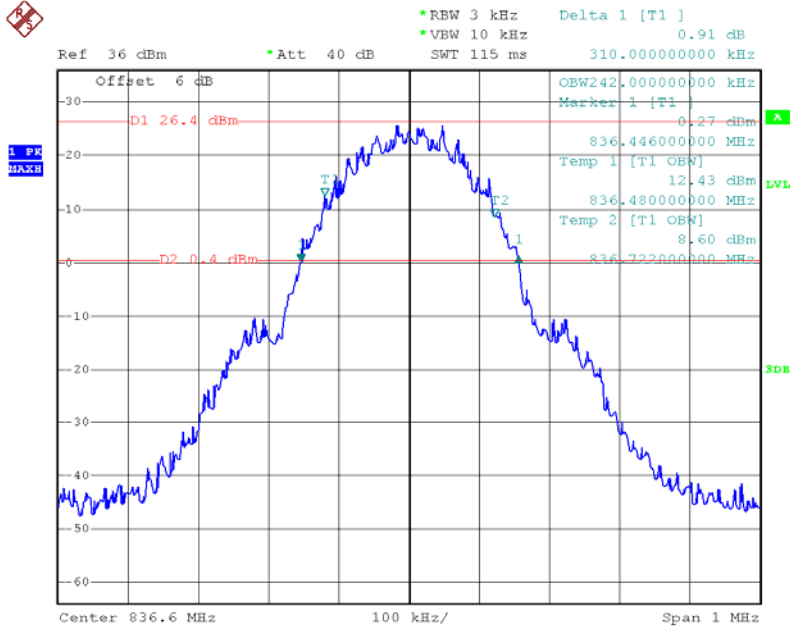

Date: 11.SEP.2013 15:30:00

### GSM1900 band middle Channel

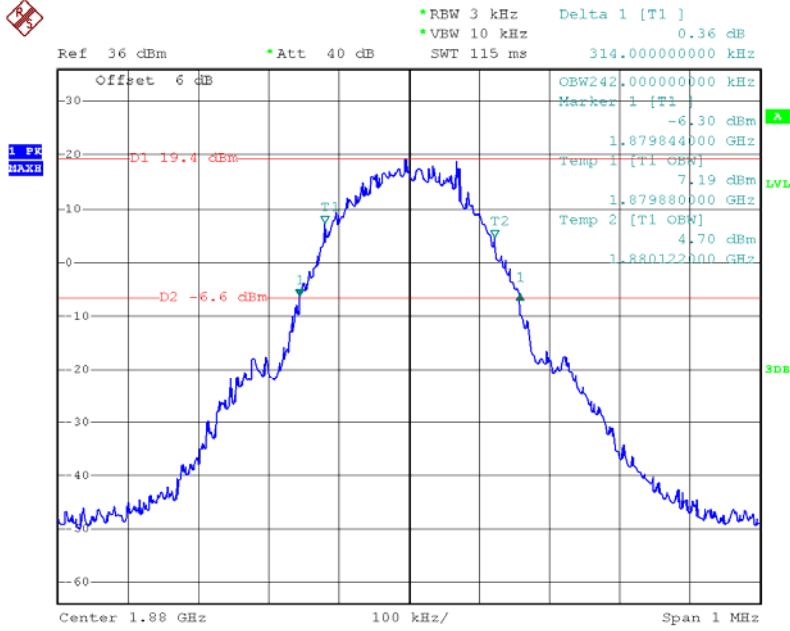

Date: 11.SEP.2013 15:47:48

### WCDMA850 band middle Channel

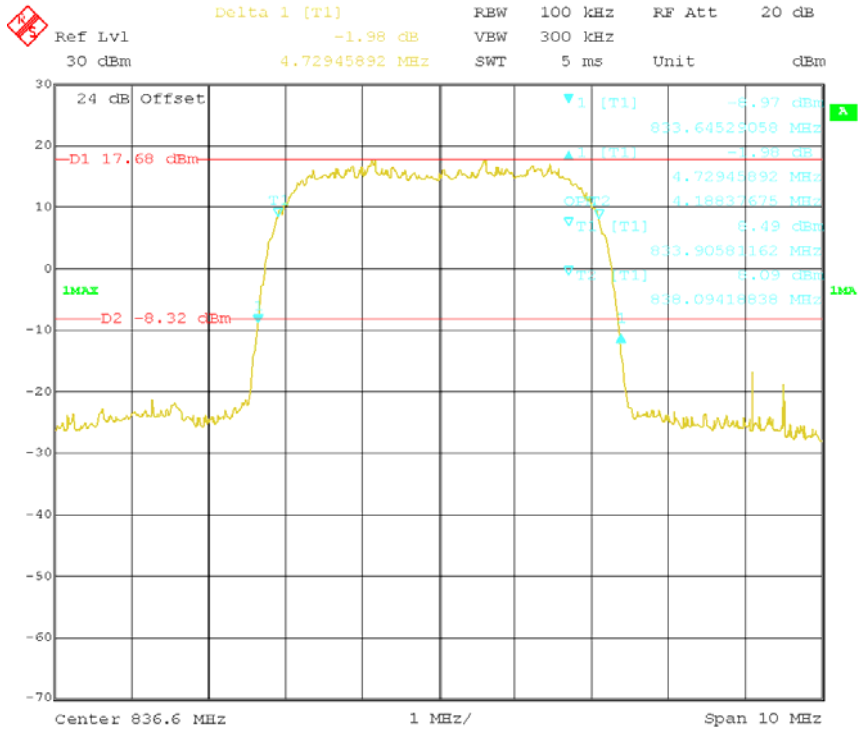

### WCDMA1900 band middle Channel

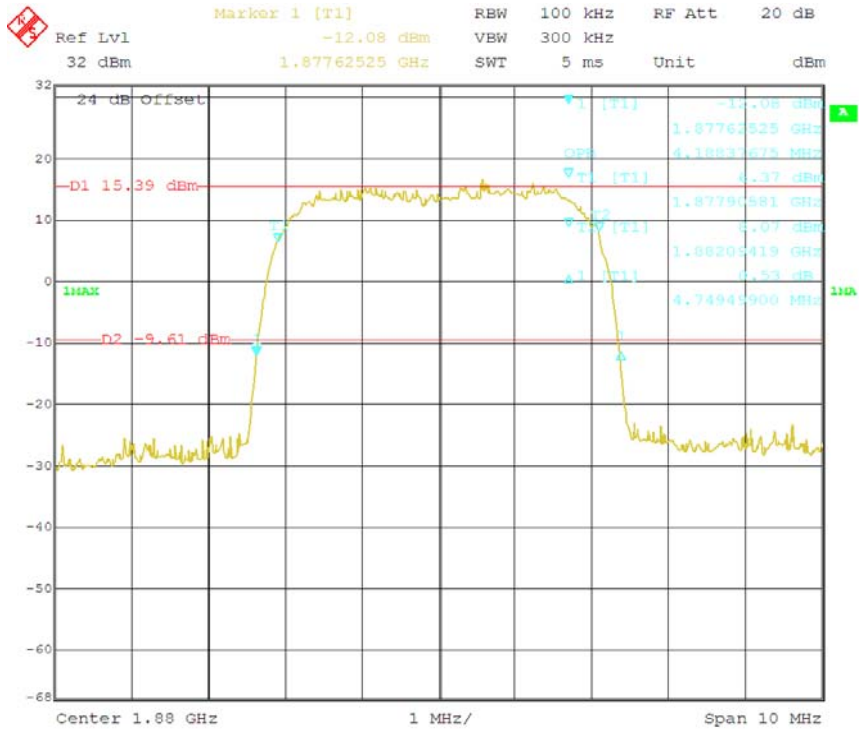

## 10. EMISSION BANDWIDTH

### 10.1.MEASUREMENT METHOD

The test set up and general procedure is similar to conducted peak output power test. Only different for setting the measurement configuration of the measuring instrument of Spectrum Analyzer.

### 10.2.PROVISIONS APPLICABLE

The emission bandwidth is defined as two points, one below the carrier center frequency and one above the carrier center frequency, outside of which all emissions are attenuated at least 26dB below the transmitter power

### 10.3.MEASUREMENT RESULT

<b>Emission Bandwidth (-26dBc) for GSM850 band</b>		
Mode	Frequency(MHz)	Emission Bandwidth (-26dBc)( kHz)
Middle Channel	836.6	310.00

<b>Emission Bandwidth (-26dBc) for PCS1900 band</b>		
Mode	Frequency(MHz)	Emission Bandwidth (-26dBc)( kHz)
Middle Channel	1880.0	314.00

<b>Emission Bandwidth (-26dBc) for WCDMA 850 band</b>		
Mode	Frequency(MHz)	Emission Bandwidth (-26dBc)( MHz)
Middle Channel	836.6	4.73

<b>Emission Bandwidth (-26dBc) for WCDMA 1900 band</b>		
Mode	Frequency(MHz)	Emission Bandwidth (-26dBc)( MHz)
Middle Channel	836.6	4.75

### GSM850 band middle Channel

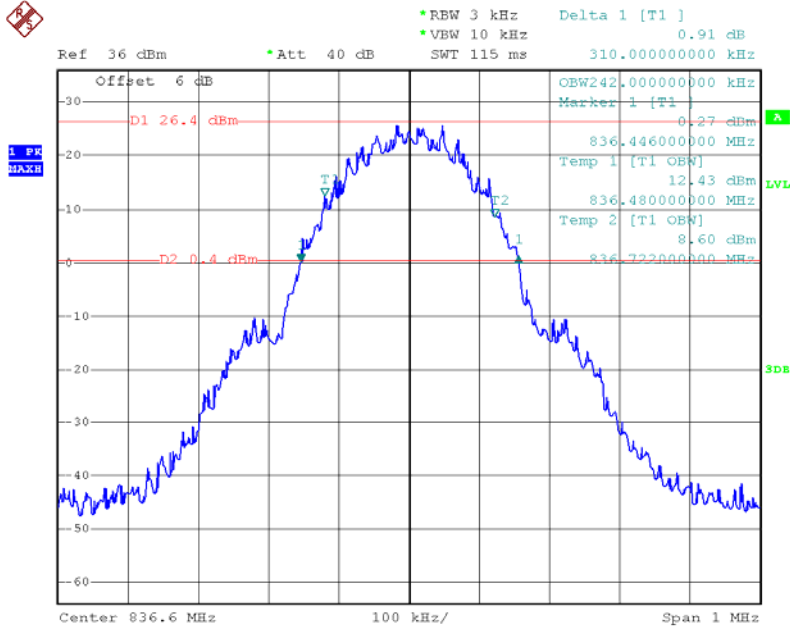

Date: 11.SEP.2013 15:30:00

### GSM1900 band middle Channel

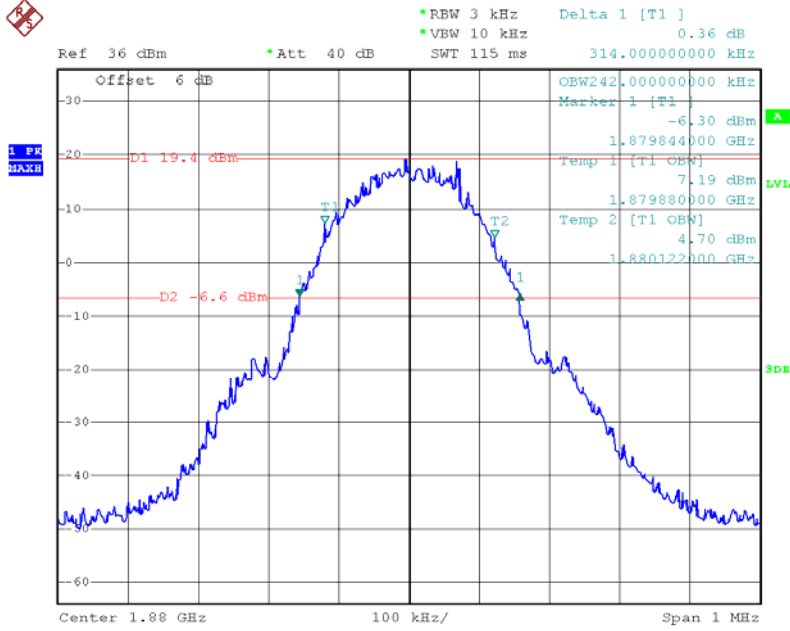

Date: 11.SEP.2013 15:47:48



### WCDMA850 band middle Channel

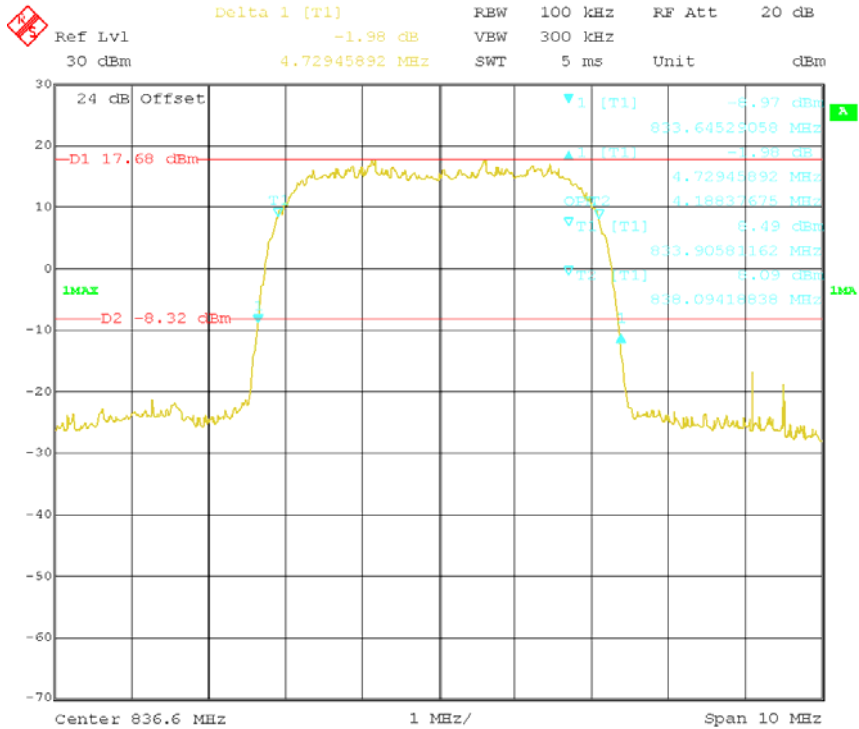

### WCDMA1900 band middle Channel

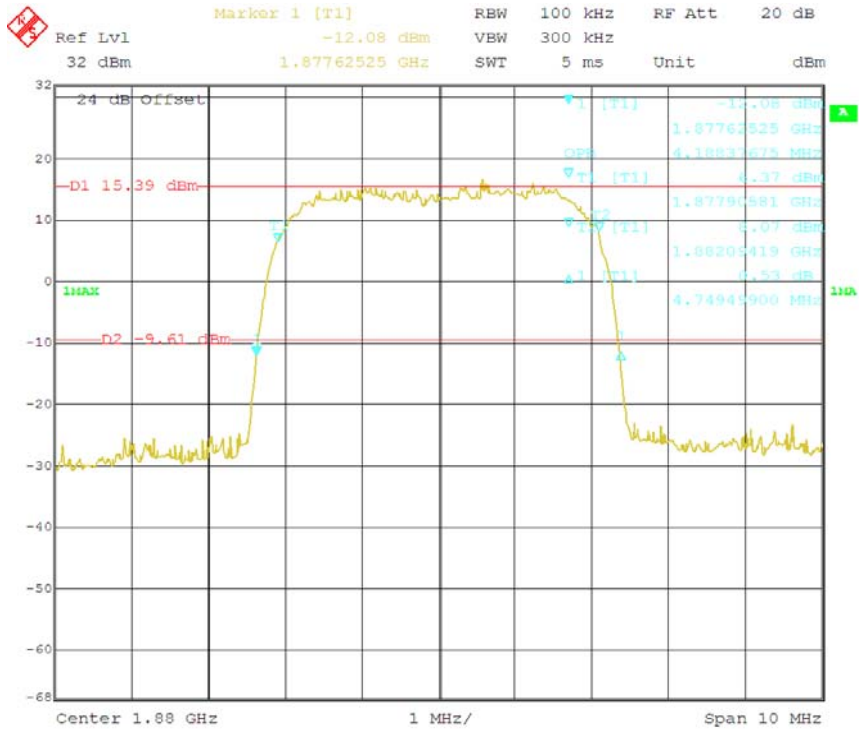

**11. BAND EDGE**

**11.1.MEASUREMENT METHOD**

The test set up and general procedure is similar to conducted peak output power test. Only different for setting the measurement configuration of the measuring instrument of Spectrum Analyzer.

**11.2.PROVISIONS APPLICABLE**

as Specified in FCC rules of 22.917(b) and 24.238(b)

**11.3.MEASUREMENT RESULT**

**Cellular Band (Part 22H)**

Channel	Emission (dBm)	Limit (dBm)
824.2MHz	-22.72	-13
848.8MHz	-24.54	-13

**PCS Band (Part 24E)**

Channel	Emission (dBm)	Limit (dBm)
1850.2MHz	-23.33	-13
1909.8MHz	-21.27	-13

**WCDMA850 Band (Part 22H)**

Channel	Emission (dBm)	Limit (dBm)
826.4MHz	-15.01	-13
846.6MHz	-25.40	-13

**WCDMA850 Band (Part 24E)**

Channel	Emission (dBm)	Limit (dBm)
826.4MHz	-16.56	-13
846.6MHz	-25.40	-13

### Low Band Edge GSM 850

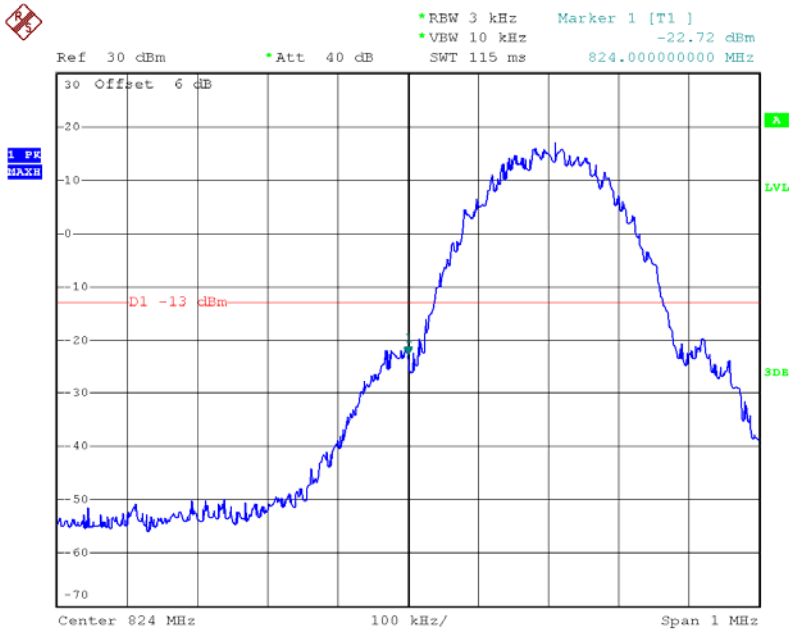

Date: 11.SEP.2013 15:57:43

### High Band Edge GSM 850

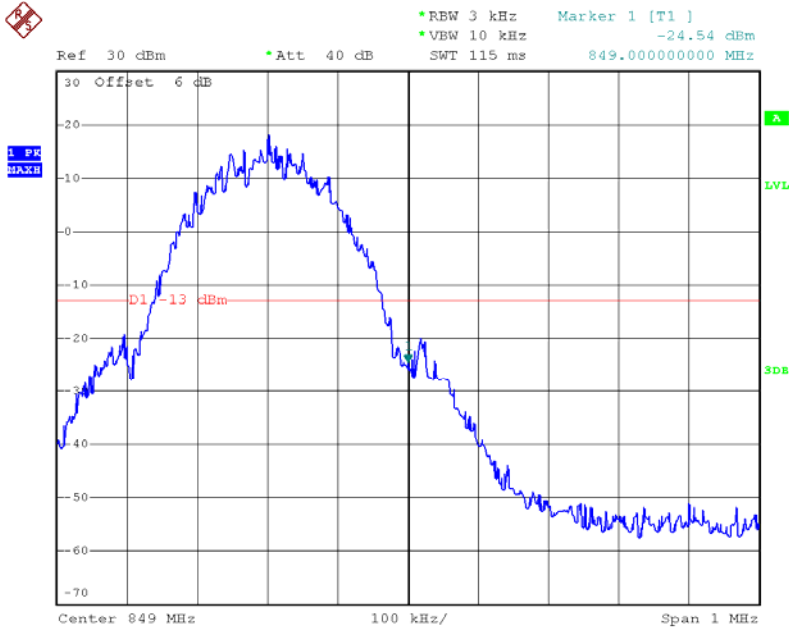

Date: 11.SEP.2013 15:58:10

### Low Band Edge PCS 1900

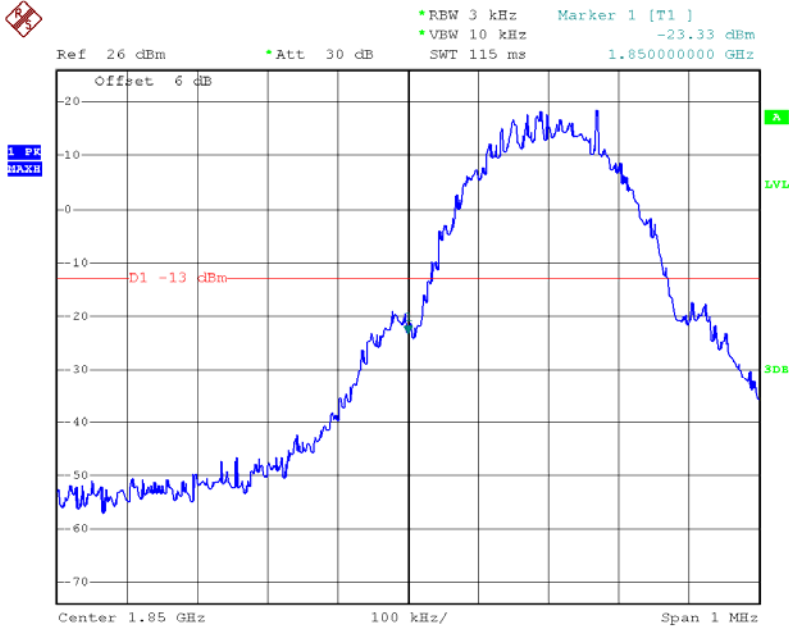

Date: 11.SEP.2013 15:41:47

### High Band Edge PCS 1900

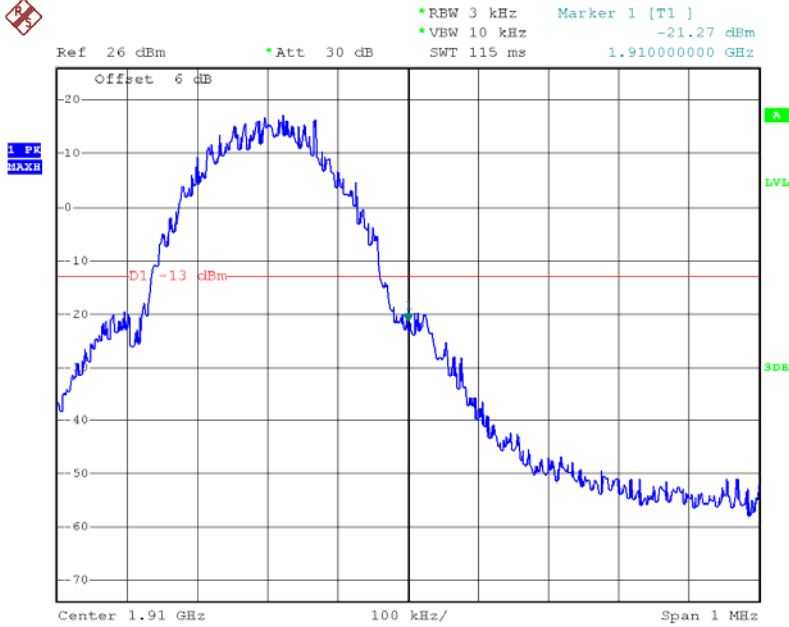

Date: 11.SEP.2013 15:42:13

### Low Band Edge WCDMA 850

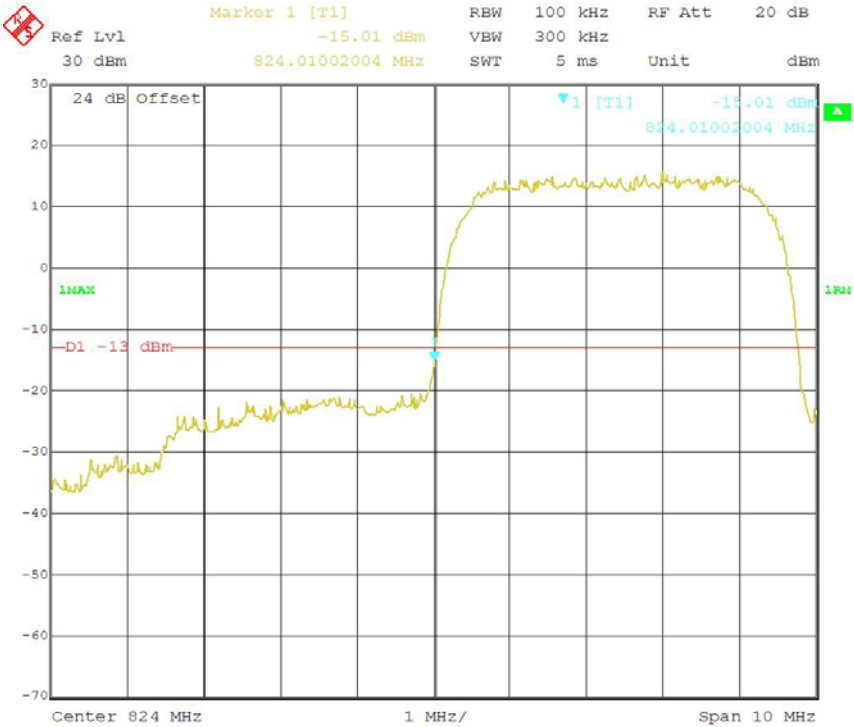

### High Band Edge WCDMA 850

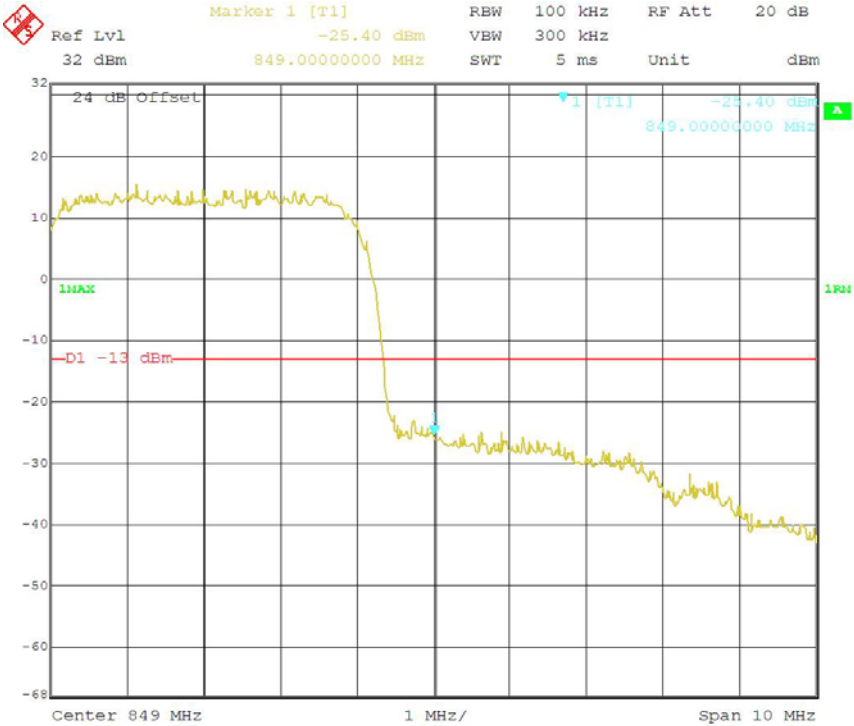

### Low Band Edge WCDMA 1900

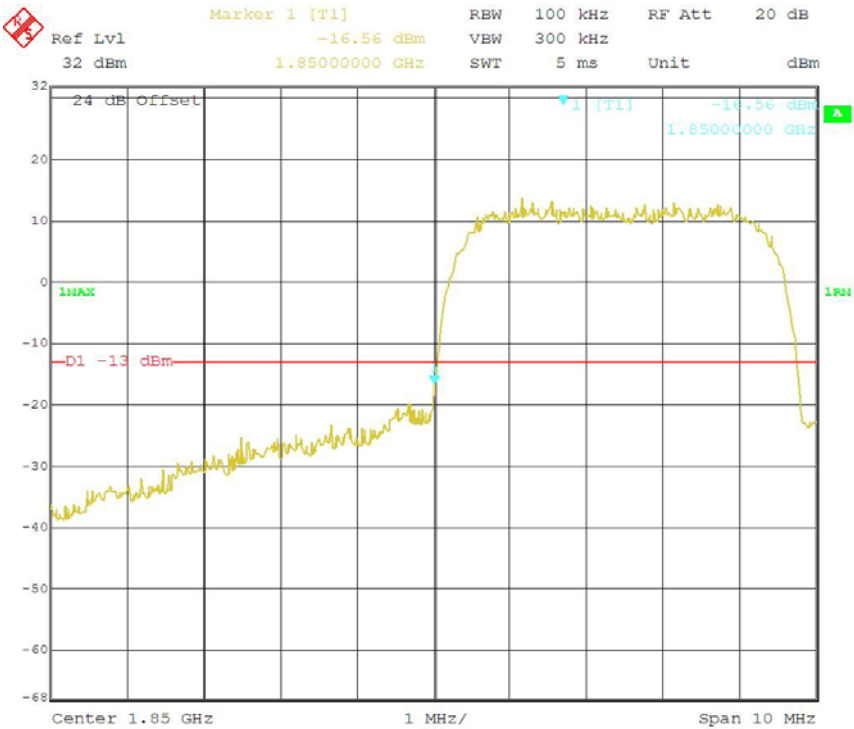

### High Band Edge WCDMA 1900

