

SAR EVALUATION REPORT

For

Nexpro International Limitada

Guadalupe, Barrio Tournon, Frente Al Hotel Villas, Oficinas Del Bufete Facio Y Canas,
San Jose-Goicoechea, Costa Rica

FCC ID: ZYPTREAT

Report Type: Original Report	Product Type: LTE Mobile phone
Test Engineer: Terry XiaHou	<i>Terry XiaHou</i>
Report Number: RSZ150930003-20	
Report Date: 2015-10-14	
Reviewed By: SAR Engineer	<i>Bell Hu</i>
Prepared By: Bay Area Compliance Laboratories Corp. (Shenzhen) 6/F, the 3rd Phase of WanLi Industrial Building, ShiHua Road, FuTian Free Trade Zone Shenzhen, Guangdong, China Tel: +86-755-33320018 Fax: +86-755-33320008 www.baclcorp.com.cn	

Attestation of Test Results		
EUT Information	Company Name	Nexpro International Limitada
	EUT Description	LTE Mobile phone
	FCC ID	ZYPTREAT
	Model Number	Treat
	Test Date	2015-10-08
Frequency	Max. SAR Level(s) Reported	Limit(W/Kg)
GSM 850	0.528 W/kg 1g Head SAR 1.044 W/kg 1g Body SAR	1.6
PCS 1900	0.417 W/kg 1g Head SAR 0.880 W/kg 1g Body SAR	
WCDMA 850	0.167 W/kg 1g Head SAR 0.315 W/kg 1g Body SAR	
WCDMA 1700	0.574 W/kg 1g Head SAR 1.120 W/kg 1g Body SAR	
WCDMA 1900	0.592 W/kg 1g Head SAR 1.295 W/kg 1g Body SAR	
LTE Band 2	0.629 W/kg 1g Head SAR 1.358 W/kg 1g Body SAR	
LTE Band 4	0.345 W/kg 1g Head SAR 0.644 W/kg 1g Body SAR	
Simultaneous	1.001 W/kg 1g Head SAR 1.544 W/kg 1g Body SAR	
Hotspot	1.544 W/kg 1g Body SAR	
Applicable Standards	ANSI / IEEE C95.1 : 2005 IEEE Standard for Safety Levels with Respect to Human Exposure to Radio Frequency Electromagnetic Fields,3 kHz to 300 GHz.	
	ANSI / IEEE C95.3 : 2002 IEEE Recommended Practice for Measurements and Computations of Radio Frequency Electromagnetic Fields With Respect to Human Exposure to Such Fields,100 kHz—300 GHz.	
	FCC 47 CFR part 2.1093 Radiofrequency radiation exposure evaluation: portable devices	
	IEEE1528:2013 IEEE Recommended Practice for Determining the Peak Spatial-Average Specific Absorption Rate (SAR) in the Human Head from Wireless Communications Devices: Measurement Techniques	
	IEC 62209-2:2010 Human exposure to radio frequency fields from hand-held and body-mounted wireless communication devices-Human models, instrumentation, and procedures-Part 2: Procedure to determine the specific absorption rate (SAR) for wireless communication devices used in close proximity to the human body (frequency range of 30 MHz to 6 GHz)	
	KDB procedures KDB 447498 D01 General RF Exposure Guidance v05r02. KDB 648474 D04 Handset SAR v01r02. KDB 865664 D01 SAR measurement 100 MHz to 6 GHz v01r03 KDB 865664 D02 RF Exposure Reporting v01r01 KDB 941225 D01 3G SAR Procedures v03 KDB 941225 D05 SAR for LTE Devices v02r03 KDB 941225 D06 Hotspot Mode v02	

Note: This wireless device has been shown to be capable of compliance for localized specific absorption rate (SAR) for General Population/Uncontrolled Exposure limits specified in ANSI/IEEE Standards and has been tested in accordance with the measurement procedures specified in IEEE 1528-2013 and RF exposure KDB procedures.

The results and statements contained in this report pertain only to the device(s) evaluated.

TABLE OF CONTENTS

DOCUMENT REVISION HISTORY	6
EUT DESCRIPTION	7
TECHNICAL SPECIFICATION	7
REFERENCE, STANDARDS, AND GUIDELINES	8
SAR LIMITS	9
FACILITIES	10
DESCRIPTION OF TEST SYSTEM	11
EQUIPMENT LIST AND CALIBRATION	18
EQUIPMENTS LIST & CALIBRATION INFORMATION	18
SAR MEASUREMENT SYSTEM VERIFICATION	19
LIQUID VERIFICATION	19
SYSTEM ACCURACY VERIFICATION	24
SAR SYSTEM VALIDATION DATA	25
EUT TEST STRATEGY AND METHODOLOGY	37
TEST POSITIONS FOR DEVICE OPERATING NEXT TO A PERSON’S EAR	37
CHEEK/TOUCH POSITION	38
EAR/TILT POSITION	38
TEST POSITIONS FOR BODY-WORN AND OTHER CONFIGURATIONS	39
SAR EVALUATION PROCEDURE	40
TEST METHODOLOGY	40
CONDUCTED OUTPUT POWER MEASUREMENT	41
PROVISION APPLICABLE	41
TEST PROCEDURE	41
RADIO CONFIGURATION	41
MAXIMUM OUTPUT POWER AMONG PRODUCTION UNITS	47
TEST RESULTS:	48
SAR MEASUREMENT RESULTS	58
SAR TEST DATA	58
SAR SIMULTANEOUS TRANSMISSION DESCRIPTION	68
SAR PLOTS (SUMMARY OF THE HIGHEST SAR VALUES)	73
APPENDIX A MEASUREMENT UNCERTAINTY	87
APPENDIX B – PROBE CALIBRATION CERTIFICATES	89
APPENDIX C DIPOLE CALIBRATION CERTIFICATES	99
APPENDIX D EUT TEST POSITION PHOTOS	126
LIQUID DEPTH ≥ 15CM	126
BODY-WORN BACK SETUP PHOTO (10MM)	126
BODY-WORN LEFT SETUP PHOTO (10MM)	127
BODY-WORN LEFT SETUP PHOTO (10MM)	127
BODY-WORN BOTTOM SETUP PHOTO (10MM)	128
LEFT HEAD TOUCH SETUP PHOTO	128
LEFT HEAD TILT SETUP PHOTO	129
RIGHT HEAD TOUCH SETUP PHOTO	129
RIGHT HEAD TILT SETUP PHOTO	130
APPENDIX E EUT PHOTOS	131
EUT – FRONT VIEW	131
EUT – BACK VIEW	131

EUT –LEFT SIDE VIEW	132
EUT – RIGHT SIDE VIEW	132
EUT – TOP VIEW	133
EUT – BOTTOM VIEW.....	133
EUT – UNCOVER VIEW.....	134
APPENDIX F INFORMATIVE REFERENCES	135

DOCUMENT REVISION HISTORY

Revision Number	Report Number	Description of Revision	Date of Revision
0	RSZ150930003-20	Original Report	2015-10-14

EUT DESCRIPTION

This report has been prepared on behalf of Nexpro International Limitada and their product, FCC ID: ZYPTREAT, Model: Treat or the EUT (Equipment under Test) as referred to in the rest of this report.

Technical Specification

Product Type	Portable
Exposure Category:	Population / Uncontrolled
Antenna Type(s):	Internal Antenna
Body-Worn Accessories:	Headset
Face-Head Accessories:	None
Multi-slot Class:	Class12
Operation Mode :	GSM Voice, EGPRS/GPRS Data, WCDMA(Rel99, HSUPA, HSDPA, DC-HSDPA, HSPA+),LTE, Wi-Fi and Bluetooth
Frequency Band:	GSM 850 : 824-849 MHz(TX) ; 869-894 MHz(RX) PCS 1900: 1850-1910 MHz(TX) ; 1930-1990 MHz(RX) WCDMA 850: 824-849 MHz(TX) ; 869-894 MHz(RX) WCDMA 1700: 1710-1755MHz(TX); 2110-2155MHz(RX) WCDMA 1900: 1850-1910 MHz(TX) ; 1930-1990 MHz(RX) LTE Band 2: 1850-1910 MHz(TX) ; 1930-1990 MHz(RX) LTE Band 4: 1710-1755 MHz(TX) ; 2110-2155 MHz(RX) Wi-Fi(802.11b/g/n20): 2412 MHz-2462 MHz Wi-Fi(802.11n40): 2422 MHz-2452 MHz Bluetooth3.0 : 2402 MHz-2480 MHz BLE:2402 MHz-2480 MHz
Conducted RF Power:	GSM 850: 32.76 dBm PCS 1900: 28.45 dBm WCDMA 850: 22.72 dBm WCDMA 1700: 22.84 dBm WCDMA 1900: 22.96 dBm LTE Band 2: 23.23 dBm LTE Band 4: 22.98 dBm Wi-Fi(802.11b/g/n20): 9.47 dBm Wi-Fi(802.11n40) : 8.99 dBm Bluetooth3.0: 7.05 dBm BLE: -3.18 dBm
Dimensions (L*W*H):	144 mm (L) × 71 mm (W) × 10 mm (H)
Power Source:	3.8 V _{DC} Rechargeable Battery
Normal Operation:	Head and Body-worn

REFERENCE, STANDARDS, AND GUIDELINES

FCC:

The Report and Order requires routine SAR evaluation prior to equipment authorization of portable transmitter devices, including portable telephones. For consumer products, the applicable limit is 1.6 mW/g as recommended by the ANSI/IEEE standard C95.1-1992 [6] for an uncontrolled environment (Paragraph 65). According to the Supplement C of OET Bulletin 65 "Evaluating Compliance with FCC Guide-lines for Human Exposure to Radio frequency Electromagnetic Fields", released on Jun 29, 2001 by the FCC, the device should be evaluated at maximum output power (radiated from the antenna) under "worst-case" conditions for normal or intended use, incorporating normal antenna operating positions, device peak performance frequencies and positions for maximum RF energy coupling.

This report describes the methodology and results of experiments performed on wireless data terminal. The objective was to determine if there is RF radiation and if radiation is found, what is the extent of radiation with respect to safety limits. SAR (Specific Absorption Rate) is the measure of RF exposure determined by the amount of RF energy absorbed by human body (or its parts) – to determine how the RF energy couples to the body or head which is a primary health concern for body worn devices. The limit below which the exposure to RF is considered safe by regulatory bodies in North America is 1.6 mW/g average over 1 gram of tissue mass.

CE:

The order requires routine SAR evaluation prior to equipment authorization of portable transmitter devices, including portable telephones. For consumer products, the applicable limit is 2 mW/g as recommended by EN62209-1 for an uncontrolled environment. According to the Standard, the device should be evaluated at maximum output power (radiated from the antenna) under "worst-case" conditions for normal or intended use, incorporating normal antenna operating positions, device peak performance frequencies and positions for maximum RF energy coupling.

This report describes the methodology and results of experiments performed on wireless data terminal. The objective was to determine if there is RF radiation and if radiation is found, what is the extent of radiation with respect to safety limits. SAR (Specific Absorption Rate) is the measure of RF exposure determined by the amount of RF energy absorbed by human body (or its parts) – to determine how the RF energy couples to the body or head which is a primary health concern for body worn devices. The limit below which the exposure to RF is considered safe by regulatory bodies in Europe is 2 mW/g average over 10 gram of tissue mass.

The test configurations were laid out on a specially designed test fixture to ensure the reproducibility of measurements. Each configuration was scanned for SAR. Analysis of each scan was carried out to characterize the above effects in the device.

SAR Limits

FCC Limit (1g Tissue)

EXPOSURE LIMITS	SAR (W/kg)	
	(General Population / Uncontrolled Exposure Environment)	(Occupational / Controlled Exposure Environment)
Spatial Average (averaged over the whole body)	0.08	0.4
Spatial Peak (averaged over any 1 g of tissue)	1.60	8.0
Spatial Peak (hands/wrists/feet/ankles averaged over 10 g)	4.0	20.0

CE Limit (10g Tissue)

EXPOSURE LIMITS	SAR (W/kg)	
	(General Population / Uncontrolled Exposure Environment)	(Occupational / Controlled Exposure Environment)
Spatial Average (averaged over the whole body)	0.08	0.4
Spatial Peak (averaged over any 10 g of tissue)	2.0	10
Spatial Peak (hands/wrists/feet/ankles averaged over 10 g)	4.0	20.0

Population/Uncontrolled Environments are defined as locations where there is the exposure of individual who have no knowledge or control of their exposure.

Occupational/Controlled Environments are defined as locations where there is exposure that may be incurred by people who are aware of the potential for exposure (i.e. as a result of employment or occupation).

General Population/Uncontrolled environments Spatial Peak limit 1.6W/kg (FCC) & 2 W/kg (CE) applied to the EUT.

FACILITIES

The test site used by Bay Area Compliance Laboratories Corp. (Shenzhen) to collect data is located at 6/F, the 3rd Phase of WanLi Industrial Building, Shi Hua Road, Fu Tian Free Trade Zone, Shenzhen, Guangdong, P.R. of China

DESCRIPTION OF TEST SYSTEM

These measurements were performed with ALSAS 10 Universal Integrated SAR Measurement system from APREL Laboratories.

ALSAS-10U System Description

ALSAS-10-U is fully compliant with the technical and scientific requirements of IEEE 1528, IEC 62209, CENELEC, ARIB, ACA, and the Federal Communications Commission. The system comprises of a six axes articulated robot which utilizes a dedicated controller. ALSAS-10U uses the latest methodologies. And FDTD modeling to provide a platform which is repeatable with minimum uncertainty.

Applications

Predefined measurement procedures compliant with the guidelines of CENELEC, IEEE, IEC, FCC, etc are utilized during the assessment for the device. Automatic detection for all SAR maxima are embedded within the core architecture for the system, ensuring that peak locations used for centering the zoom scan are within a 1mm resolution and a 0.05mm repeatable position. System operation range currently available up-to 6 GHz in simulated tissue.

Area Scans

Area scans are defined prior to the measurement process being executed with a user defined variable spacing between each measurement point (integral) allowing low uncertainty measurements to be conducted. Scans defined for FCC applications utilize a 10mm² step integral, with 1mm interpolation used to locate the peak SAR area used for zoom scan assessments.

Where the system identifies multiple SAR peaks (which are within 25% of peak value) the system will provide the user with the option of assessing each peak location individually for zoom scan averaging.

Zoom Scan (Cube Scan Averaging)

The averaging zoom scan volume utilized in the ALSAS-10U software is in the shape of a cube and the side dimension of a 1 g or 10 g mass is dependent on the density of the liquid representing the simulated tissue. A density of 1000 kg/m³ is used to represent the head and body tissue density and not the phantom liquid density, in order to be consistent with the definition of the liquid dielectric properties, i.e. the side length of the 1 g cube is 10mm, with the side length of the 10 g cube 21,5mm.

When the cube intersects with the surface of the phantom, it is oriented so that 3 vertices touch the surface of the shell or the center of a face is tangent to the surface. The face of the cube closest to the surface is modified in order to conform to the tangent surface.

The zoom scan integer steps can be user defined so as to reduce uncertainty, but normal practice for typical test applications (including FCC) utilize a physical step of 5x5x8 (8mmx8mmx5mm) providing a volume of 32mm³ in the X & Y axis, and 35mm in the Z axis.



ALSAS-10U Interpolation and Extrapolation Uncertainty

The overall uncertainty for the methodology and algorithms the used during the SAR calculation was evaluated using the data from IEEE 1528 based on the example f3 algorithm:

$$f_3(x, y, z) = A \frac{a^2}{\frac{a^2}{4} + x'^2 + y'^2} \cdot \left(e^{-\frac{2z}{a}} + \frac{a^2}{2(a + 2z)^2} \right)$$

Isotropic E-Field Probe

The isotropic E-Field probe has been fully calibrated and assessed for isotropicity, and boundary effect within a controlled environment. Depending on the frequency for which the probe is calibrated the method utilized for calibration will change.

The E-Field probe utilizes a triangular sensor arrangement as detailed in the diagram below:

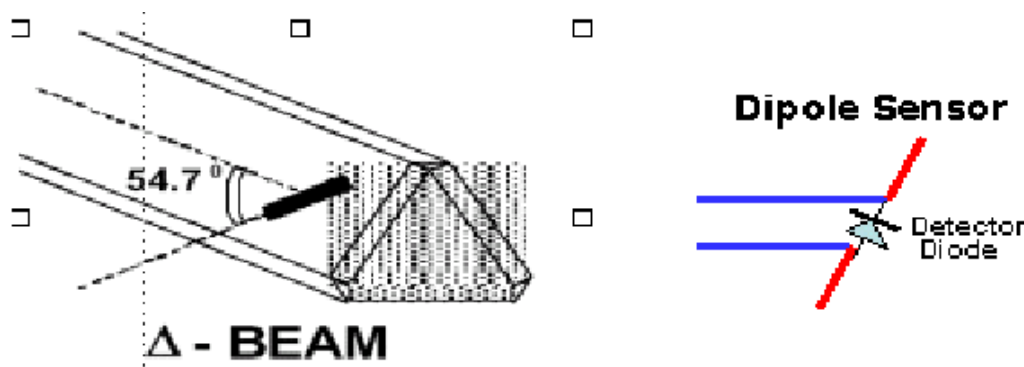

SAR is assessed with a calibrated probe which moves at a default height of 5mm from the center of the diode, which is mounted to the sensor, to the phantom surface (in the Z Axis). The 5mm offset height has been selected so as to minimize any resultant boundary effect due to the probe being in close proximity to the phantom surface.

The following algorithm is an example of the function used by the system for linearization of the output from the probe when measuring complex modulation schemes.

$$V_i = U_i + U_i^2 \cdot \frac{cf}{dcp_i}$$

Isotropic E-Field Probe Specification

Calibration Method	Frequency Dependent Below 1 GHz Calibration in air performed in a TEM Cell Above 1 GHz Calibration in air performed in waveguide
Sensitivity	0.70 $\mu\text{V}/(\text{V}/\text{m})^2$ to 0.85 $\mu\text{V}/(\text{V}/\text{m})^2$
Dynamic Range	0.0005 W/kg to 100 W/kg
Isotropic Response	Better than 0.1 dB
Diode Compression Point (DCP)	Calibration for Specific Frequency
Probe Tip Diameter	< 2.9 mm
Sensor Offset	1.56 (+/- 0.02 mm)
Probe Length	289 mm
Video Bandwidth	@ 500 Hz: 1 dB @ 1.02 kHz: 3 dB
Boundary Effect	Less than 2.1% for distance greater than 0.58 mm
Spatial Resolution	The spatial resolution uncertainty is less than 1.5% for 4.9mm diameter probe. The spatial resolution uncertainty is less than 1.0% for 2.5mm diameter probe

Boundary Detection Unit and Probe Mounting Device

ALSAS-10U incorporates a boundary detection unit with a sensitivity of 0.05mm for detecting all types of surfaces. The robust design allows for detection during probe tilt (probe normalize) exercises, and utilizes a second stage emergency stop. The signal electronics are fed directly into the robot controller for high accuracy surface detection in lateral and axial detection modes (X, Y, & Z).

The probe is mounted directly onto the Boundary Detection unit for accurate tooling and displacement calculations controlled by the robot kinematics. The probe is connect to an isolated probe interconnect where the output stage of the probe is fed directly into the amplifier stage of the Daq-Paq.

Daq-Paq (Analog to Digital Electronics)

ALSAS-10U incorporates a fully calibrated Daq-Paq (analog to digital conversion system) which has a 4 channel input stage, sent via a 2 stage auto-set amplifier module. The input signal is amplified accordingly so as to offer a dynamic range from 5 μV to 800mV. Integration of the fields measured is carried out at board level utilizing a Co-Processor which then sends the measured fields down into the main computational module in digitized form via an RS232 communications port. Probe linearity and duty cycle compensation is carried out within the main Daq-Paq module.

ADC	12 Bit
Amplifier Range	20 mV to 200 mV and 150 mV to 800 mV
Field Integration	Local Co-Processor utilizing proprietary integration algorithms
Number of Input Channels	4 in total 3 dedicated and 1 spare
Communication	Packet data via RS232

Axis Articulated Robot

ALSAS-10U utilizes a six axis articulated robot, which is controlled using a Pentium based real-time movement controller. The movement kinematics engine utilizes proprietary (Thermo CRS) interpolation and extrapolation algorithms, which allow full freedom of movement for each of the six joints within the working envelope. Utilization of joint 6 allows for full probe rotation with a tolerance better than 0.05mm around the central axis.



Robot/Controller Manufacturer	Thermo CRS
Number of Axis	Six independently controlled axis
Positioning Repeatability	0.05 mm
Controller Type	Single phase Pentium based C500C
Robot Reach	710 mm
Communication	RS232 and LAN compatible

ALSAS Universal Workstation

ALSAS Universal workstation allows for repeatability and fast adaptability. It allows users to do calibration, testing and measurements using different types of phantoms with one set up, which significantly speeds up the measurement process.

Universal Device Positioner

The universal device positioner allows complete freedom of movement of the EUT. Developed to hold a EUT in a free-space scenario any additional loading attributable to the material used in the construction of the positioner has been eliminated. Repeatability has been enhanced through the linear scales which form the design used to indicate positioning for any given test scenario in all major axes. A 15° tilt indicator is included for the of aid cheek to tilt movements for head SAR analysis. Overall uncertainty for measurements have been reduced due to the design of the Universal device positioner, which allows positioning of a device in as near to a free-space scenario as possible, and by providing the means for complete repeatability.



Phantom Types

The ALSAS-10U allows the integration of multiple phantom types. SAM Phantoms fully compliant with IEEE 1528, Universal Phantom, and Universal Flat.

APREL SAM Phantoms

The SAM phantoms developed using the IEEE SAM CAD file. They are fully compliant with the requirements for both IEEE 1528 and FCC Supplement C. Both the left and right SAM phantoms are interchangeable, transparent and include the IEEE 1528 grid with visible NF and MB lines.

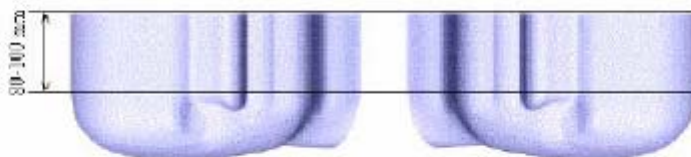

APREL Laboratories Universal Phantom

The Universal Phantom is used on the ALSAS-10U as a system validation phantom. The Universal Phantom has been fully validated both experimentally from 800MHz to 6GHz and numerically using XFDTD numerical software.

The shell thickness is 2mm overall, with a 4mm spacer located at the NF/MB intersection providing an overall thickness of 6mm in line with the requirements of IEEE-1528.

The design allows for fast and accurate measurements, of handsets, by allowing the conservative SAR to be evaluated at on frequency for both left and right head experiments in one measurement.

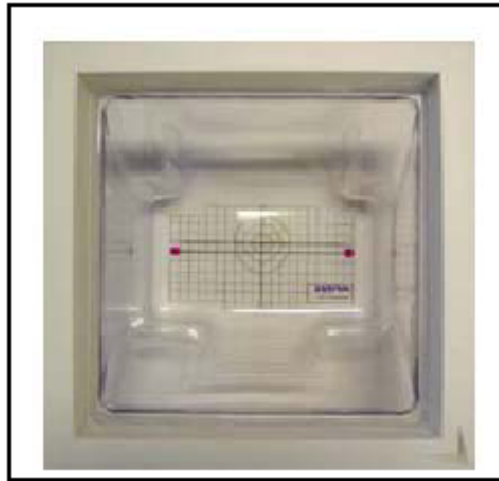

Tissue Dielectric Parameters for Head and Body Phantoms

The head tissue dielectric parameters recommended by the IEEE SCC-34/SC-2 in P1528 have been incorporated in the following table. These head parameters are derived from planar layer models simulating the highest expected SAR for the dielectric properties and tissue thickness variations in a human head. Other head and body tissue parameters that have not been specified in P1528 are derived from the tissue dielectric parameters computed from the 4-Cole-Cole equations described in Reference [12] and extrapolated according to the head parameters specified in P1528.

Ingredients (% by weight)	Frequency (MHz)									
	450		835		915		1900		2450	
Tissue Type	Head	Body	Head	Body	Head	Body	Head	Body	Head	Body
Water	38.56	51.16	41.45	52.4	41.05	56.0	54.9	40.4	62.7	73.2
Salt (Nacl)	3.95	1.49	1.45	1.4	1.35	0.76	0.18	0.5	0.5	0.04
Sugar	56.32	46.78	56.0	45.0	56.5	41.76	0.0	58.0	0.0	0.0
HEC	0.98	0.52	1.0	1.0	1.0	1.21	0.0	1.0	0.0	0.0
Bactericide	0.19	0.05	0.1	0.1	0.1	0.27	0.0	0.1	0.0	0.0
Triton x-100	0.0	0.0	0.0	0.0	0.0	0.0	0.0	0.0	36.8	0.0
DGBE	0.0	0.0	0.0	0.0	0.0	0.0	44.92	0.0	0.0	26.7
Dielectric Constant	43.42	58.0	42.54	56.1	42.0	56.8	39.9	54.0	39.8	52.5
Conductivity (s/m)	0.85	0.83	0.91	0.95	1.0	1.07	1.42	1.45	1.88	1.78

Recommended Tissue Dielectric Parameters for Head and Body

Frequency (MHz)	Head Tissue		Body Tissue	
	ϵ_r	σ (S/m)	ϵ_r	σ (S/m)
150	52.3	0.76	61.9	0.80
300	45.3	0.87	58.2	0.92
450	43.5	0.87	56.7	0.94
835	41.5	0.90	55.2	0.97
900	41.5	0.97	55.0	1.05
915	41.5	0.98	55.0	1.06
1450	40.5	1.20	54.0	1.30
1610	40.3	1.29	53.8	1.40
1800-2000	40.0	1.40	53.3	1.52
2450	39.2	1.80	52.7	1.95
3000	38.5	2.40	52.0	2.73
5800	35.3	5.27	48.2	6.00

EQUIPMENT LIST AND CALIBRATION

Equipments List & Calibration Information

Equipment	Model	Calibration Date	Calibration Due Date	S/N
CRS F3 robot	ALS-F3	N/A	N/A	RAF0805352
CRS F3 Software	ALS-F3-SW	N/A	N/A	N/A
CRS C500C controller	ALS-C500	N/A	N/A	RCF0805379
Probe mounting device & Boundary Detection Sensor System	ALS-PMDPS-3	N/A	N/A	120-00270
Universal Work Station	ALS-UWS	N/A	N/A	100-00157
Data Acquisition Package	ALS-DAQ-PAQ-3	2014-10-14	2015-10-14	110-00212
Miniature E-Field Probe	ALS-E-020	2014-10-14	2015-10-14	500-00283
Dipole, 835MHz	ALS-D-835-S-2	2014-10-08	2017-10-08	180-00558
Dipole, 1750MHz	ALS-D-1750-S-2	2013-10-08	2016-10-08	198-00304
Dipole, 1900MHz	ALS-D-1900-S-2	2014-10-09	2017-10-09	210-00710
Dipole Spacer	ALS-DS-U	N/A	N/A	250-00907
Device holder/Positioner	ALS-H-E-SET-2	N/A	N/A	170-00510
Left ear SAM phantom	ALS-P-SAM-L	N/A	N/A	130-00311
Right ear SAM phantom	ALS-P-SAM-R	N/A	N/A	140-00359
UniPhantom	ALS-P-UP-1	N/A	N/A	150-00413
Simulated Tissue 835 MHz Head	ALS-TS-835-H	Each Time	Each Time	270-01002
Simulated Tissue 835 MHz Body	ALS-TS-835-B	Each Time	Each Time	270-02101
Simulated Tissue 1750 MHz Head	ALS-TS-1750-H	Each Time	Each Time	295-01103
Simulated Tissue 1750 MHz Body	ALS-TS-1750-B	Each Time	Each Time	295-02102
Simulated Tissue 1900 MHz Head	ALS-TS-1900-H	Each Time	Each Time	295-01103
Simulated Tissue 1900 MHz Body	ALS-TS-1900-B	Each Time	Each Time	295-02102
Directional couple	DC6180A	N/A	N/A	0325849
Power Amplifier	5S1G4	N/A	N/A	71377
Attenuator	3dB	N/A	N/A	5402
Dielectric probe kit	HP85070B	2015-06-13	2016-06-13	US33020324
Network analyzer	8752C	2015-06-03	2016-06-03	3410A02356
Synthesized Sweeper	HP 8341B	2015-06-03	2016-06-03	2624A00116
UNIVERSAL RADIO COMMUNICATION TESTER	CMU200	2014-11-23	2015-11-23	106891
WIDEBAND RADIO COMMUNICATION TESTER	CMW500	2015-04-19	2016-04-19	114772
8960 Series 10 Wireless Communication Test Set	E5515C	2015-01-13	2016-01-13	MY50266471
EMI Test Receiver	ESCI	2015-06-13	2016-06-13	101746

SAR MEASUREMENT SYSTEM VERIFICATION

Liquid Verification

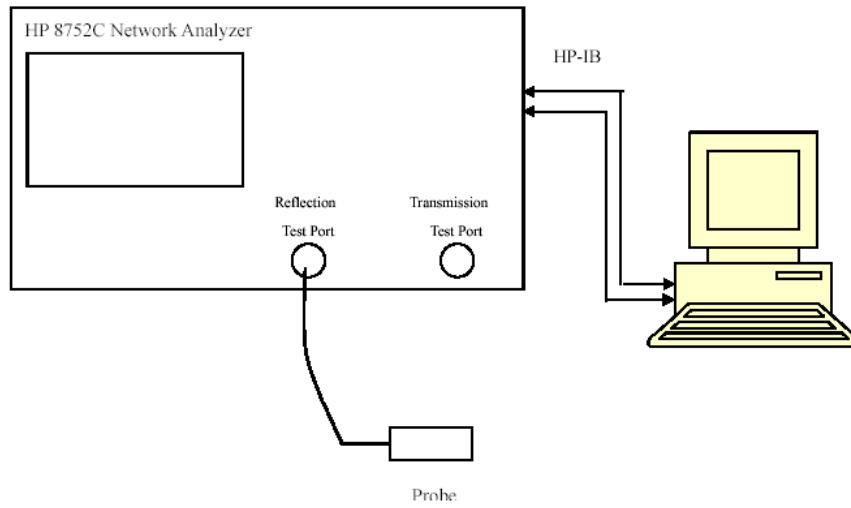

Liquid Verification Setup Block Diagram

Liquid Verification Results

Frequency	Liquid Type	Liquid Parameter		Target Value		Delta (%)		Tolerance (%)
		ϵ_r	σ (S/m)	ϵ_r	σ (S/m)	$\Delta\epsilon_r$	$\Delta\sigma$ (S/m)	
824.2	Head	41.03	0.90	41.50	0.90	-1.133	0.000	±5
	Body	53.84	0.95	55.20	0.97	-2.464	-2.062	±5
826.4	Head	41.03	0.90	41.50	0.90	-1.133	0.000	±5
	Body	53.83	0.95	55.20	0.97	-2.482	-2.062	±5
836.6	Head	41.07	0.92	41.50	0.90	-1.036	2.222	±5
	Body	53.77	0.96	55.20	0.97	-2.591	-1.031	±5
846.6	Head	41.09	0.91	41.50	0.90	-0.988	1.111	±5
	Body	53.80	0.97	55.20	0.97	-2.536	0.000	±5
848.8	Head	41.10	0.92	41.50	0.90	-0.964	2.222	±5
	Body	53.78	0.98	55.20	0.97	-2.572	1.031	±5
1712.4	Head	39.55	1.35	40.08	1.37	-1.322	-1.460	±5
	Body	51.90	1.49	53.43	1.49	-2.864	0.000	±5
1720.0	Head	39.39	1.38	40.08	1.37	-1.722	0.730	±5
	Body	51.92	1.49	53.43	1.49	-2.826	0.000	±5
1732.5	Head	39.40	1.38	40.08	1.37	-1.697	0.730	±5
	Body	51.95	1.50	53.43	1.49	-2.770	0.671	±5
1732.6	Head	39.40	1.38	40.08	1.37	-1.697	0.730	±5
	Body	51.95	1.50	53.43	1.49	-2.770	0.671	±5
1745.0	Head	39.46	1.40	40.08	1.37	-1.547	2.190	±5
	Body	51.85	1.52	53.43	1.49	-2.957	2.013	±5
1752.6	Head	39.40	1.42	40.08	1.37	-1.697	3.650	±5
	Body	51.91	1.53	53.43	1.49	-2.845	2.685	±5
1850.2	Head	39.73	1.38	40.00	1.40	-0.675	-1.429	±5
	Body	51.85	1.50	53.30	1.52	-2.720	-1.316	±5
1852.4	Head	39.58	1.38	40.00	1.40	-1.050	-1.429	±5
	Body	51.95	1.49	53.30	1.52	-2.533	-1.974	±5
1860.0	Head	39.66	1.38	40.00	1.40	-0.850	-1.429	±5
	Body	51.92	1.51	53.30	1.52	-2.589	-0.658	±5
1880.0	Head	39.56	1.39	40.00	1.40	-1.100	-0.714	±5
	Body	51.78	1.52	53.30	1.52	-2.852	0.000	±5
1900.0	Head	39.70	1.42	40.00	1.40	-0.750	1.429	±5
	Body	52.05	1.52	53.30	1.52	-2.345	0.000	±5
1907.6	Head	39.72	1.41	40.00	1.40	-0.700	0.714	±5
	Body	52.08	1.53	53.30	1.52	-2.289	0.658	±5
1909.8	Head	39.62	1.42	40.00	1.40	-0.950	1.429	±5
	Body	52.09	1.54	53.30	1.52	-2.270	1.316	±5

*Liquid Verification was performed on 2015-10-08

Please refer to the following tables.

835 MHz Head				835 MHz Body		
Frequency (MHz)	e'	e''		Frequency (MHz)	e'	e''
824.0	41.0297	19.6710		824.0	53.8438	20.6588
824.5	41.0521	19.6715		824.5	53.8678	20.6986
825.0	41.0929	19.6931		825.0	53.8565	20.6475
825.5	41.0442	19.7343		825.5	53.8131	20.6614
826.0	41.0493	19.7260		826.0	53.8252	20.6536
826.5	41.0338	19.6903		826.5	53.8261	20.7048
827.0	41.0908	19.7490		827.0	53.8303	20.6653
827.5	41.0087	19.7585		827.5	53.8344	20.6855
828.0	41.0222	19.6690		828.0	53.8611	20.6588
828.5	41.0926	19.6854		828.5	53.7719	20.6719
829.0	41.0501	19.7213		829.0	53.8681	20.6698
829.5	41.0979	19.7734		829.5	53.8312	20.6391
830.0	41.0016	19.6758		830.0	53.8313	20.6998
830.5	41.0570	19.7248		830.5	53.8439	20.6863
831.0	41.0084	19.6638		831.0	53.8461	20.6619
831.5	41.0299	19.7309		831.5	53.8718	20.6378
832.0	41.0013	19.7355		832.0	53.8005	20.6850
832.5	41.0848	19.7085		832.5	53.8356	20.7106
833.0	41.0248	19.7673		833.0	53.8308	20.6501
833.5	41.0603	19.7655		833.5	53.8490	20.6595
834.0	41.0906	19.7619		834.0	53.8279	20.6941
834.5	41.0999	19.7572		834.5	53.8574	20.6950
835.0	41.0188	19.7255		835.0	53.8609	20.6884
835.5	41.0589	19.7221		835.5	53.8206	20.6977
836.0	41.0782	19.7031		836.0	53.7756	20.6348
836.5	41.0736	19.7007		836.5	53.7670	20.6285
837.0	41.0402	19.7485		837.0	53.8276	20.6235
837.5	41.0284	19.7318		837.5	53.8450	20.6881
838.0	41.0926	19.6632		838.0	53.7976	20.6623
838.5	41.0243	19.6776		838.5	53.7727	20.6273
839.0	41.0606	19.7000		839.0	53.7913	20.6738
839.5	41.0963	19.6964		839.5	53.8576	20.6182
840.0	41.0823	19.3708		840.0	53.8053	20.6395
840.5	41.0580	19.3775		840.5	53.7785	20.6542
841.0	41.0146	19.4678		841.0	53.7767	20.6779
841.5	41.0357	19.4456		841.5	53.7864	20.6614
842.0	41.0386	19.3986		842.0	53.7747	20.6781
842.5	41.1029	19.3789		842.5	53.7863	20.6531
843.0	41.0628	19.3925		843.0	53.7772	20.6655
843.5	41.0159	19.3986		843.5	53.8123	20.6636
844.0	41.0410	19.4335		844.0	53.8303	20.6475
844.5	41.0896	19.4407		844.5	53.8638	20.6407
845.0	41.0783	19.4168		845.0	53.8007	20.6541
845.5	41.0390	19.3915		845.5	53.7839	20.6190
846.0	41.0278	19.4509		846.0	53.7887	20.6693
846.5	41.0045	19.4288		846.5	53.7984	20.6210
847.0	41.0447	19.4180		847.0	53.8637	20.6884
847.5	41.0753	19.4010		847.5	53.7673	20.6591
848.0	41.0823	19.3783		848.0	53.8424	20.6890
848.5	41.0269	19.4213		848.5	53.8505	20.6602
849.0	41.1031	19.4633		849.0	53.7781	20.6876

1750 MHz Head			1750 MHz Body		
Frequency (MHz)	e'	e''	Frequency (MHz)	e'	e''
1710.0	39.2720	14.2130	1710.0	51.9931	15.6216
1711.5	39.5293	14.1120	1711.5	51.8945	15.6619
1713.0	39.5789	14.2111	1713.0	51.9105	15.6506
1714.5	39.2853	14.4701	1714.5	51.8414	15.6749
1716.0	39.2106	14.3035	1716.0	51.9012	15.6463
1717.5	39.6188	14.0837	1717.5	51.9094	15.6084
1719.0	39.3189	14.3413	1719.0	51.9463	15.6201
1720.5	39.4484	14.4632	1720.5	51.9163	15.6154
1722.0	39.1731	14.4427	1722.0	51.8492	15.6720
1723.5	39.1595	14.5286	1723.5	51.8819	15.6302
1725.0	39.5273	14.0837	1725.0	51.9199	15.5566
1726.5	39.2843	14.3691	1726.5	51.8987	15.6157
1728.0	39.5205	14.4604	1728.0	51.9554	15.6110
1729.5	39.2268	14.3879	1729.5	51.8390	15.6740
1731.0	39.2399	14.1239	1731.0	51.8691	15.6572
1732.5	39.3984	14.3166	1732.5	51.9521	15.6237
1734.0	39.4548	14.1187	1734.0	51.8967	15.6616
1735.5	39.3575	14.2167	1735.5	51.8537	15.6015
1737.0	39.3941	14.1224	1737.0	51.8658	15.6914
1738.5	39.3674	14.5816	1738.5	51.8688	15.6530
1740.0	39.4842	14.2812	1740.0	51.9807	15.6822
1741.5	39.4674	14.4966	1741.5	51.8377	15.6200
1743.0	39.1230	14.3194	1743.0	51.8527	15.6729
1744.5	39.4087	14.5761	1744.5	51.8443	15.7087
1746.0	39.5596	14.2005	1746.0	51.8695	15.6060
1747.5	39.1975	14.3159	1747.5	51.9187	15.6782
1749.0	39.2163	14.3876	1749.0	51.8392	15.6175
1750.5	39.3506	14.2129	1750.5	51.9359	15.6044
1752.0	39.4833	14.5513	1752.0	51.8741	15.6843
1753.5	39.1848	14.4327	1753.5	51.9815	15.6956
1755.0	39.4058	14.1338	1755.0	51.8905	15.6750
1756.5	39.3477	14.5532	1756.5	51.9201	15.6122
1758.0	39.3883	14.3861	1758.0	51.9074	15.5973
1759.5	39.3969	14.4347	1759.5	51.9806	15.5725
1761.0	39.1022	14.1416	1761.0	51.8640	15.5672
1762.5	39.4617	14.2988	1762.5	51.8891	15.3862
1764.0	39.3191	14.2959	1764.0	51.9547	15.5879
1765.5	39.1721	14.5781	1765.5	51.9202	15.4209
1767.0	39.1884	14.3546	1767.0	51.8898	15.4885
1768.5	39.2482	14.3986	1768.5	51.9513	15.5483
1770.0	39.5514	14.5463	1770.0	51.9029	15.3186
1771.5	39.1894	14.1279	1771.5	51.9929	15.4000
1773.0	39.1829	14.2290	1773.0	51.8485	15.4799
1774.5	39.2931	14.1765	1774.5	51.9885	15.4015
1776.0	39.3844	14.4345	1776.0	51.9543	15.3957
1777.5	39.3827	14.5431	1777.5	51.8636	15.3198
1779.0	39.4527	14.4421	1779.0	51.9001	15.5222
1780.5	39.2308	14.3512	1780.5	51.8600	15.4138
1782.0	39.5626	14.5632	1782.0	51.9095	15.3735
1783.5	39.2921	14.1104	1783.5	51.8902	15.3761
1785.0	39.3337	14.3870	1785.0	51.9496	15.5549

1900 MHz Head				1900 MHz Body		
Frequency (MHz)	e'	e''		Frequency (MHz)	e'	e''
1850.0	39.7297	13.4083		1850.0	51.8506	14.5694
1851.2	39.5586	13.3352		1851.2	52.0957	14.4946
1852.4	39.5780	13.3557		1852.4	51.9481	14.4499
1853.6	39.6542	13.2521		1853.6	52.0744	14.4363
1854.8	39.5630	13.3507		1854.8	51.9082	14.4661
1856.0	39.7295	13.3268		1856.0	51.8354	14.4445
1857.2	39.6298	13.3501		1857.2	51.8120	14.4695
1858.4	39.6137	13.2810		1858.4	51.8261	14.4125
1859.6	39.6443	13.3814		1859.6	51.8791	14.5744
1860.8	39.7104	13.4104		1860.8	51.9919	14.5334
1862.0	39.6876	13.3487		1862.0	51.9198	14.4565
1863.2	39.6471	13.2638		1863.2	51.8784	14.5576
1864.4	39.6472	13.3538		1864.4	51.8650	14.4270
1865.6	39.6714	13.4229		1865.6	51.9039	14.5220
1866.8	39.6719	13.4071		1866.8	51.9927	14.4516
1868.0	39.6249	13.2938		1868.0	51.9103	14.4661
1869.2	39.6903	13.3875		1869.2	51.9576	14.4559
1870.4	39.6283	13.3996		1870.4	51.8715	14.5701
1871.6	39.5602	13.3611		1871.6	52.0620	14.4304
1872.8	39.7375	13.3141		1872.8	51.7341	14.5055
1874.0	39.7181	13.4348		1874.0	51.8426	14.5103
1875.2	39.6327	13.3372		1875.2	51.8818	14.4328
1876.4	39.6039	13.3676		1876.4	51.9092	14.4837
1877.6	39.6524	13.2636		1877.6	51.7871	14.5260
1878.8	39.5440	13.4138		1878.8	52.0586	14.4333
1880.0	39.5587	13.2595		1880.0	51.7775	14.5280
1881.2	39.7080	13.3660		1881.2	51.9671	14.5062
1882.4	39.6892	13.3176		1882.4	51.8018	14.4298
1883.6	39.6412	13.2811		1883.6	51.9917	14.5617
1884.8	39.5787	13.3618		1884.8	52.0431	14.5716
1886.0	39.7040	13.4056		1886.0	51.7376	14.4169
1887.2	39.6783	13.2579		1887.2	51.8494	14.4642
1888.4	39.6593	13.2768		1888.4	51.7852	14.4921
1889.6	39.6479	13.4010		1889.6	51.8333	14.4767
1890.8	39.6219	13.3671		1890.8	51.9581	14.4220
1892.0	39.5589	13.2629		1892.0	51.7455	14.4423
1893.2	39.6278	13.3392		1893.2	51.9186	14.5301
1894.4	39.5828	13.2676		1894.4	51.9765	14.5650
1895.6	39.6145	13.3000		1895.6	51.8899	14.4571
1896.8	39.6650	13.3827		1896.8	51.8702	14.5512
1898.0	39.7123	13.4016		1898.0	51.8541	14.4518
1899.2	39.7171	13.2506		1899.2	52.0214	14.4775
1900.4	39.6961	13.4349		1900.4	52.0499	14.4149
1901.6	39.5785	13.3593		1901.6	52.0291	14.4877
1902.8	39.6762	13.4203		1902.8	51.8707	14.5150
1904.0	39.6707	13.3676		1904.0	52.0907	14.4126
1905.2	39.7156	13.3442		1905.2	52.0769	14.4235
1906.4	39.5499	13.3311		1906.4	52.0366	14.5334
1907.6	39.7200	13.2721		1907.6	52.0840	14.4546
1908.8	39.6208	13.2523		1908.8	52.0854	14.5118
1910.0	39.6155	13.4158		1910.0	52.0877	14.5073

System Accuracy Verification

Prior to the assessment, the system validation kit was used to test whether the system was operating within its specifications of $\pm 10\%$. The validation results are tabulated below. And also the corresponding SAR plot is attached as well in the SAR plots files.

System Verification Setup Block Diagram

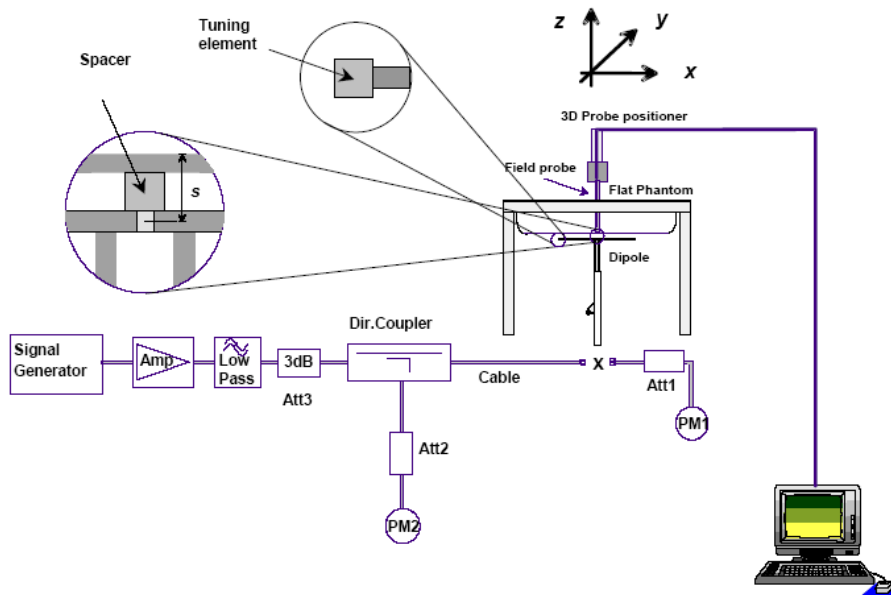

Probe and dipole antenna List and Detail

Manufacturer	Description	Model	Serial Number	Calibration Date	Calibration Due Date
APREL	Probe	ALS-E-020	500-00283	2014-10-14	2015-10-14
APREL	Dipole antenna(835MHz)	ALS-D-835-S-2	180-00558	2014-10-08	2017-10-08
APREL	Dipole antenna(1750MHz)	ALS-D-1750-S-2	198-00304	2013-10-08	2016-10-08
APREL	Dipole antenna(1900MHz)	ALS-D-1900-S-2	210-00710	2014-10-09	2017-10-09

System Accuracy Check Results:

Date	Frequency Band	Liquid Type	Measured SAR (W/Kg)		Target Value (W/Kg)	Delta (%)	Tolerance (%)
2015-10-08	835	Head	1g	10.130	9.773	3.653	± 10
		Body	1g	9.552	9.736	-1.890	± 10
	1750	Head	1g	35.637	37.020	-3.736	± 10
		Body	1g	36.315	36.650	-0.914	± 10
	1900	Head	1g	40.533	39.481	2.665	± 10
		Body	1g	39.877	39.715	0.408	± 10

*All SAR values are normalized to 1 Watt forward power.

SAR SYSTEM VALIDATION DATA**Test Laboratory: Bay Area Compliance Lab Corp. (Shenzhen)****System Performance Check 835 MHz Head Liquid****Dipole 835 MHz; Type: ALS-D-835-S-2; S/N: 180-00558**

Product Data

Device Name : Dipole 835 MHz
Serial No. : 180-00558
Type : Dipole
Model : ALS-D-835-S-2
Frequency Band : 835
Max. Transmit Pwr : 1 W
Drift Time : 3 min(s)
Power Drift-Start : 10.038 W/kg
Power Drift-Finish : 9.923 W/kg
Power Drift (%) : -1.061

Phantom Data

Name : APREL-Uni
Type : Uni-Phantom
Serial No. : System Default
Location : Center
Description : Default
Phantom Data

Tissue Data

Type : Head
Serial No. : 270-01002
Frequency : 835.0 MHz
Last Calib. Date : 08-Oct-2015
Temperature : 20.00 °C
Ambient Temp. : 21.00 °C
Humidity : 56.00 RH%
Epsilon : 41.02 F/m
Sigma : 0.92 S/m
Density : 1000.00 kg/cu. m

Probe Data

Name : E-Field
Model : E-020
Type : E-Field Triangle
Serial No. : 500-00283
Last Calib. Date : 14-Oct-2014
Frequency Band : 835
Duty Cycle Factor : 1
Conversion Factor : 5.9
Probe Sensitivity : 1.20 1.20 1.20 $\mu\text{V}/(\text{V}/\text{m})^2$
Compression Point : 95.00 mV
Offset : 1.56 mm

Measurement Data

Crest Factor : 1
Scan Type : Complete
Tissue Temp. : 21.00 °C
Ambient Temp. : 21.00 °C
Area Scan : 7x9x1 : Measurement x=10mm, y=10mm, z=4mm
Zoom Scan : 7x7x7 : Measurement x=5mm, y=5mm, z=5mm

1 gram SAR value : 10.130 W/kg
 10 gram SAR value : 6.582 W/kg
 Area Scan Peak SAR : 10.536 W/kg
 Zoom Scan Peak SAR : 17.362 W/kg

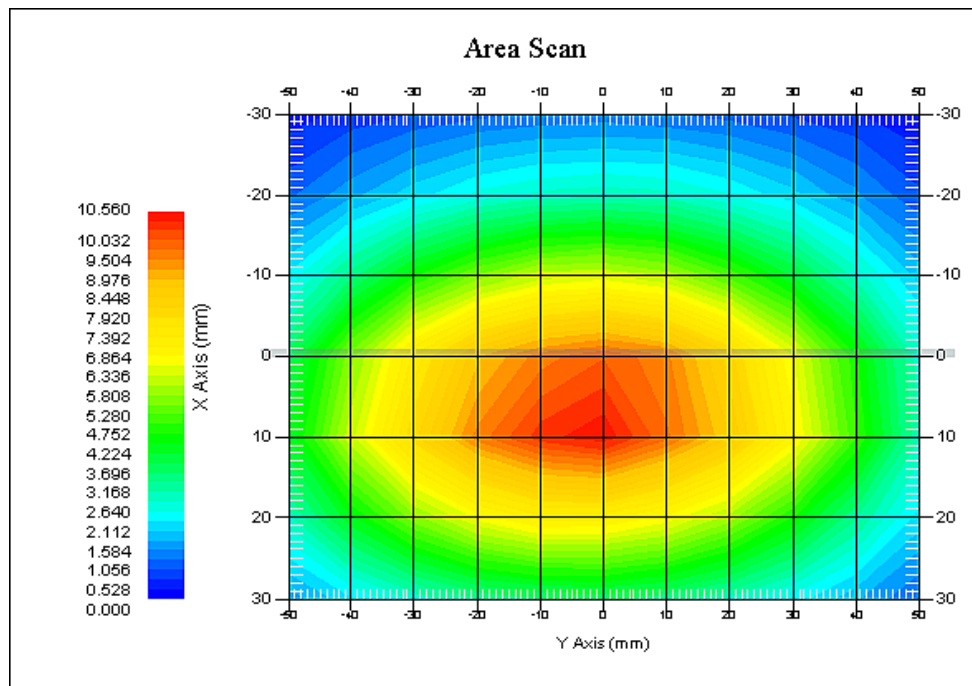

835 MHz System Validation with Head Tissue

Test Laboratory: Bay Area Compliance Lab Corp. (Shenzhen)**System Performance Check 835 MHz Body Liquid****Dipole 835 MHz; Type: ALS-D-835-S-2; S/N: 180-00558**

Product Data

Device Name : Dipole 835 MHz
Serial No. : 180-00558
Type : Dipole
Model : ALS-D-835-S-2
Frequency Band : 835
Max. Transmit Pwr : 1 W
Drift Time : 3 min(s)
Power Drift-Start : 9.655 W/kg
Power Drift-Finish : 9.521 W/kg
Power Drift (%) : 1.379

Phantom Data

Name : APREL-Uni
Type : Uni-Phantom
Serial No. : System Default
Location : Center
Description : Default
Phantom Data

Tissue Data

Type : Body
Serial No. : 270-02101
Frequency : 835.0 MHz
Last Calib. Date : 08-Oct-2015
Temperature : 20.00 °C
Ambient Temp. : 21.00 °C
Humidity : 56.00 RH%
Epsilon : 53.86 F/m
Sigma : 0.96 S/m
Density : 1000.00 kg/cu. m

Probe Data

Name : E-Field
Model : E-020
Type : E-Field Triangle
Serial No. : 500-00283
Last Calib. Date : 14-Oct-2014
Frequency Band : 835
Duty Cycle Factor : 1
Conversion Factor : 5.9
Probe Sensitivity : 1.20 1.20 1.20 $\mu\text{V}/(\text{V}/\text{m})^2$
Compression Point : 95.00 mV
Offset : 1.56 mm

Measurement Data

Crest Factor : 1
Scan Type : Complete
Tissue Temp. : 21.00 °C
Ambient Temp. : 21.00 °C
Area Scan : 7x9x1 : Measurement x=10mm, y=10mm, z=4mm
Zoom Scan : 7x7x7 : Measurement x=5mm, y=5mm, z=5mm

1 gram SAR value : 9.552 W/kg
10 gram SAR value : 6.222 W/kg
Area Scan Peak SAR : 9.720 W/kg
Zoom Scan Peak SAR : 15.598 W/kg

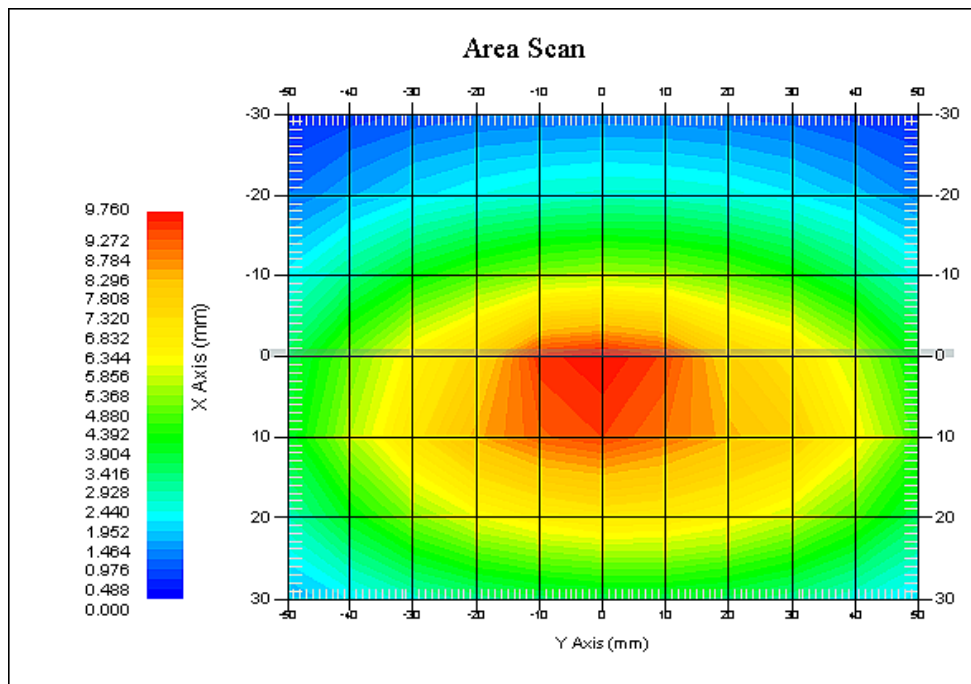

835 MHz System Validation with Body Tissue

Test Laboratory: Bay Area Compliance Lab Corp. (Shenzhen)**System Performance Check 1750 MHz Head Liquid****Dipole 1750 MHz; Type: ALS-D-1750-S-2; S/N: 198-00304**

Product Data

Device Name : Dipole 1750MHz
Serial No. : 198-00304
Type : Dipole
Model : ALS-D-1750-S-2
Frequency Band : 1700
Max. Transmit Pwr : 1 W
Drift Time : 3 min(s)
Power Drift-Start : 32.132 W/kg
Power Drift-Finish : 32.831 W/kg
Power Drift (%) : 2.151

Phantom Data

Name : APREL-Uni
Type : Uni-Phantom
Serial No. : System Default
Location : Center
Description : Default

Tissue Data

Type : Head
Serial No. : 295-01101
Frequency : 1750.00 MHz
Last Calib. Date : 08-Oct-2015
Temperature : 20.00 °C
Ambient Temp. : 21.00 °C
Humidity : 56.00 RH%
Epsilon : 39.30 F/m
Sigma : 1.39 S/m
Density : 1000.00 kg/cu. M

Probe Data

Name : E-Field
Model : E-020
Type : E-Field Triangle
Serial No. : 500-00283
Last Calib. Date : 14-Oct-2014
Frequency Band : 1750
Duty Cycle Factor : 1
Conversion Factor : 5.4
Probe Sensitivity : 1.20 1.20 1.20 $\mu\text{V}/(\text{V}/\text{m})^2$
Compression Point : 95.00 mV
Offset : 1.56 mm

Measurement Data

Crest Factor : 1
Scan Type : Complete
Tissue Temp. : 20.00 °C
Ambient Temp. : 20.00 °C
Area Scan : 7x9x1 : Measurement x=10mm, y=10mm, z=4mm
Zoom Scan : 7x7x7 : Measurement x=5mm, y=5mm, z=5mm

1 gram SAR value : 35.637 W/kg
10 gram SAR value : 19.739 W/kg
Area Scan Peak SAR : 36.538 W/kg
Zoom Scan Peak SAR : 68.793 W/kg

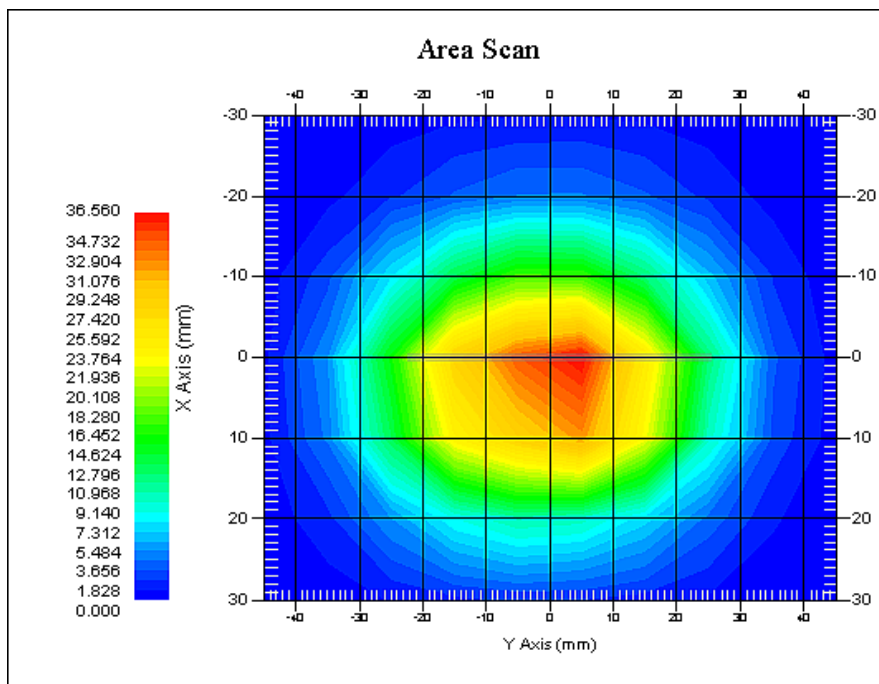

1750 MHz System Validation with Head Tissue

Test Laboratory: Bay Area Compliance Lab Corp. (Shenzhen)**System Performance Check 1750 MHz Body Liquid****Dipole 1750 MHz; Type: ALS-D-1750-S-2; S/N: 198-00304**

Product Data

Device Name : Dipole 1750MHz
Serial No. : 198-00304
Type : Dipole
Model : ALS-D-1750-S-2
Frequency Band : 1700
Max. Transmit Pwr : 1 W
Drift Time : 3 min(s)
Power Drift-Start : 35.233 W/kg
Power Drift-Finish : 35.756 W/kg
Power Drift (%) : 1.426

Phantom Data

Name : APREL-Uni
Type : Uni-Phantom
Serial No. : System Default
Location : Center
Description : Default

Tissue Data

Type : Body
Serial No. : 295-02105
Frequency : 1750.00 MHz
Last Calib. Date : 08-Oct-2015
Temperature : 20.00 °C
Ambient Temp. : 21.00 °C
Humidity : 56.00 RH%
Epsilon : 51.89 F/m
Sigma : 1.52 S/m
Density : 1000.00 kg/cu. m

Probe Data

Name : E-Field
Model : E-020
Type : E-Field Triangle
Serial No. : 500-00283
Last Calib. Date : 14-Oct-2014
Frequency Band : 1750
Duty Cycle Factor : 1
Conversion Factor : 5.3
Probe Sensitivity : 1.20 1.20 1.20 $\mu\text{V}/(\text{V}/\text{m})^2$
Compression Point : 95.00 mV
Offset : 1.56 mm

Measurement Data

Crest Factor : 1
Scan Type : Complete
Tissue Temp. : 20.00 °C
Ambient Temp. : 21.00 °C
Area Scan : 7x9x1 : Measurement x=10mm, y=10mm, z=4mm
Zoom Scan : 7x7x7 : Measurement x=5mm, y=5mm, z=5mm

1 gram SAR value : 36.315 W/kg
10 gram SAR value : 19.137 W/kg
Area Scan Peak SAR : 37.157 W/kg
Zoom Scan Peak SAR : 66.537 W/kg

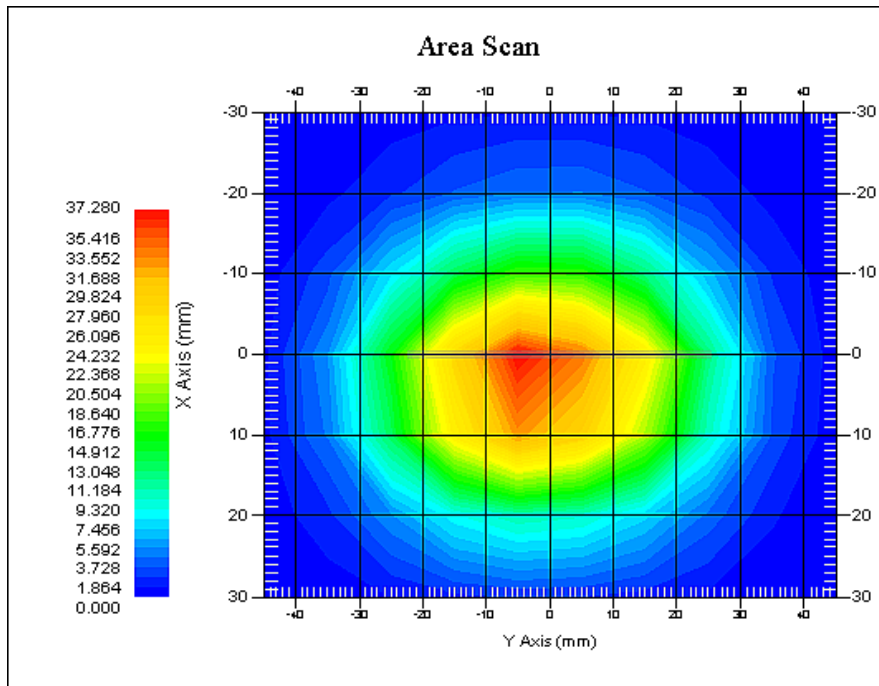

1750 MHz System Validation with Body Tissue

Test Laboratory: Bay Area Compliance Lab Corp. (Shenzhen)**System Performance Check 1900 MHz Head Liquid****Dipole 1900 MHz; Type: ALS-D-1900-S-2; S/N: 210-00710**

Product Data

Device Name : Dipole 1900MHz
Serial No. : 210-00710
Type : Dipole
Model : ALS-D-1900-S-2
Frequency Band : 1900
Max. Transmit Pwr : 1 W
Drift Time : 3 min(s)
Power Drift-Start : 37.862 W/kg
Power Drift-Finish : 37.331 W/kg
Power Drift (%) : -1.316

Phantom Data

Name : APREL-Uni
Type : Uni-Phantom
Serial No. : System Default
Location : Center
Description : Default

Tissue Data

Type : Head
Serial No. : 295-01103
Frequency : 1900.00 MHz
Last Calib. Date : 08-Oct-2015
Temperature : 20.00 °C
Ambient Temp. : 21.00 °C
Humidity : 56.00 RH%
Epsilon : 39.70 F/m
Sigma : 1.41 S/m
Density : 1000.00 kg/cu. M

Probe Data

Name : E-Field
Model : E-020
Type : E-Field Triangle
Serial No. : 500-00283
Last Calib. Date : 14-Oct-2014
Frequency Band : 1900
Duty Cycle Factor : 1
Conversion Factor : 4.8
Probe Sensitivity : 1.20 1.20 1.20 $\mu\text{V}/(\text{V}/\text{m})^2$
Compression Point : 95.00 mV
Offset : 1.56 mm

Measurement Data

Crest Factor : 1
Scan Type : Complete
Tissue Temp. : 20.00 °C
Ambient Temp. : 20.00 °C
Area Scan : 7x9x1 : Measurement x=10mm, y=10mm, z=4mm
Zoom Scan : 7x7x7 : Measurement x=5mm, y=5mm, z=5mm

1 gram SAR value : 40.533 W/kg
10 gram SAR value : 20.926 W/kg
Area Scan Peak SAR : 42.010 W/kg
Zoom Scan Peak SAR : 71.280 W/kg

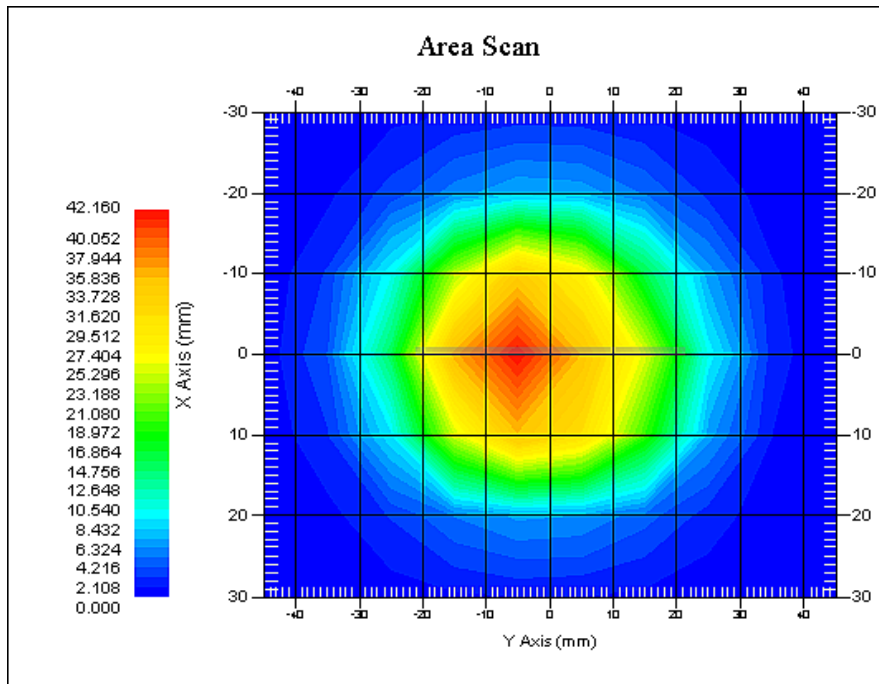

1900 MHz System Validation with Head Tissue

Test Laboratory: Bay Area Compliance Lab Corp. (Shenzhen)**System Performance Check 1900 MHz Body Liquid****Dipole 1900 MHz; Type: ALS-D-1900-S-2; S/N: 210-00710**

Product Data

Device Name : Dipole 1900MHz
Serial No. : 210-00710
Type : Dipole
Model : ALS-D-1900-S-2
Frequency Band : 1900
Max. Transmit Pwr : 1 W
Drift Time : 3 min(s)
Power Drift-Start : 38.436 W/kg
Power Drift-Finish : 38.899 W/kg
Power Drift (%) : 1.185

Phantom Data

Name : APREL-Uni
Type : Uni-Phantom
Serial No. : System Default
Location : Center
Description : Default

Tissue Data

Type : Body
Serial No. : 295-02102
Frequency : 1900.00 MHz
Last Calib. Date : 08-Oct-2015
Temperature : 20.00 °C
Ambient Temp. : 21.00 °C
Humidity : 56.00 RH%
Epsilon : 52.04 F/m
Sigma : 1.52 S/m
Density : 1000.00 kg/cu. m

Probe Data

Name : E-Field
Model : E-020
Type : E-Field Triangle
Serial No. : 500-00283
Last Calib. Date : 14-Oct-2014
Frequency Band : 1900
Duty Cycle Factor : 1
Conversion Factor : 4.5
Probe Sensitivity : 1.20 1.20 1.20 $\mu\text{V}/(\text{V}/\text{m})^2$
Compression Point : 95.00 mV
Offset : 1.56 mm

Measurement Data

Crest Factor : 1
Scan Type : Complete
Tissue Temp. : 20.00 °C
Ambient Temp. : 21.00 °C
Area Scan : 7x9x1 : Measurement x=10mm, y=10mm, z=4mm
Zoom Scan : 7x7x7 : Measurement x=5mm, y=5mm, z=5mm

1 gram SAR value : 39.877 W/kg
10 gram SAR value : 21.233 W/kg
Area Scan Peak SAR : 41.840 W/kg
Zoom Scan Peak SAR : 73.802 W/kg

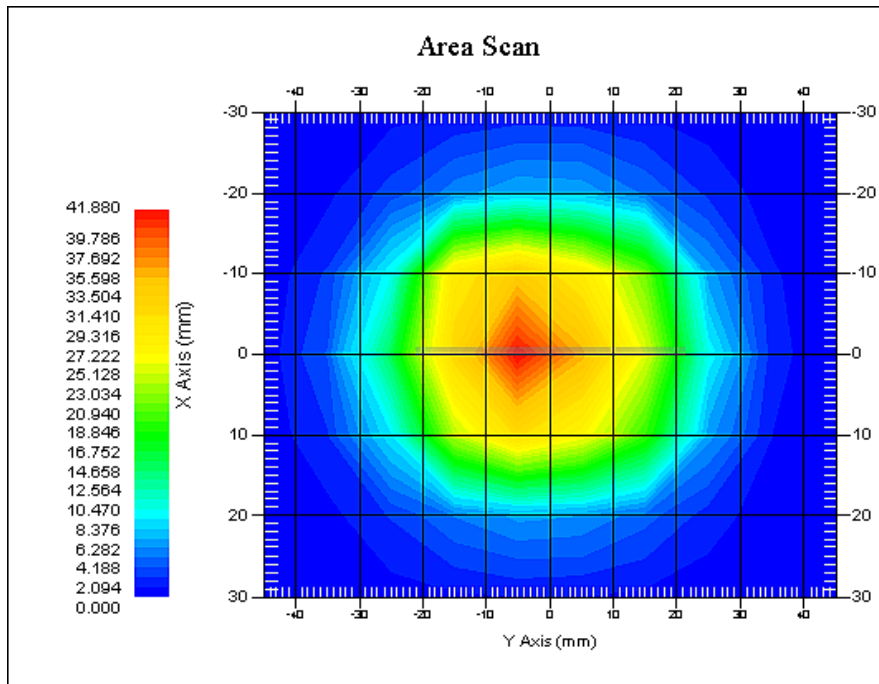

1900 MHz System Validation with Body Tissue

EUT TEST STRATEGY AND METHODOLOGY

Test Positions for Device Operating Next to a Person’s Ear

This category includes most wireless handsets with fixed, retractable or internal antennas located toward the top half of the device, with or without a foldout, sliding or similar keypad cover. The handset should have its earpiece located within the upper ¼ of the device, either along the centerline or off-centered, as perceived by its users. This type of handset should be positioned in a normal operating position with the “test device reference point” located along the “vertical centerline” on the front of the device aligned to the “ear reference point”. The “test device reference point” should be located at the same level as the center of the earpiece region. The “vertical centerline” should bisect the front surface of the handset at its top and bottom edges. A “ear reference point” is located on the outer surface of the head phantom on each ear spacer. It is located 1.5 cm above the center of the ear canal entrance in the “phantom reference plane” defined by the three lines joining the center of each “ear reference point” (left and right) and the tip of the mouth.

A handset should be initially positioned with the earpiece region pressed against the ear spacer of a head phantom. For the SCC-34/SC-2 head phantom, the device should be positioned parallel to the “N-F” line defined along the base of the ear spacer that contains the “ear reference point”. For interim head phantoms, the device should be positioned parallel to the cheek for maximum RF energy coupling. The “test device reference point” is aligned to the “ear reference point” on the head phantom and the “vertical centerline” is aligned to the “phantom reference plane”. This is called the “initial ear position”. While maintaining these three alignments, the body of the handset is gradually adjusted to each of the following positions for evaluating SAR:

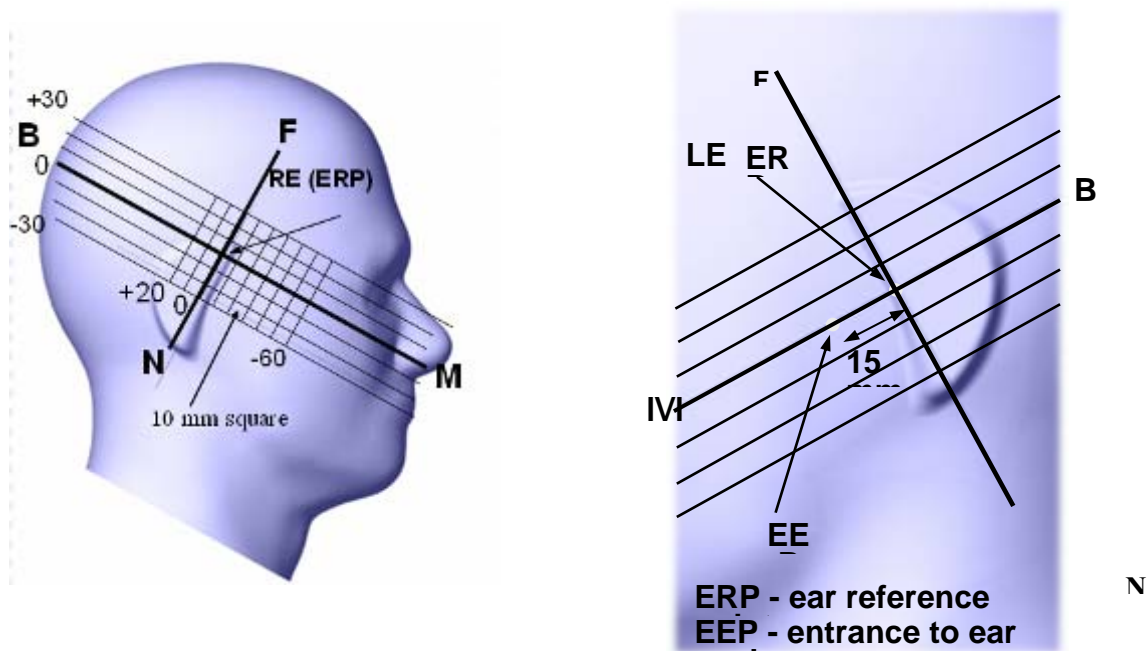

Cheek/Touch Position

The device is brought toward the mouth of the head phantom by pivoting against the “ear reference point” or along the “N-F” line for the SCC-34/SC-2 head phantom.

This test position is established:

- When any point on the display, keypad or mouthpiece portions of the handset is in contact with the phantom.
- (or) When any portion of a foldout, sliding or similar keypad cover opened to its intended self-adjusting normal use position is in contact with the cheek or mouth of the phantom.

For existing head phantoms – when the handset loses contact with the phantom at the pivoting point, rotation should continue until the device touches the cheek of the phantom or breaks its last contact from the ear spacer.

Cheek /Touch Position

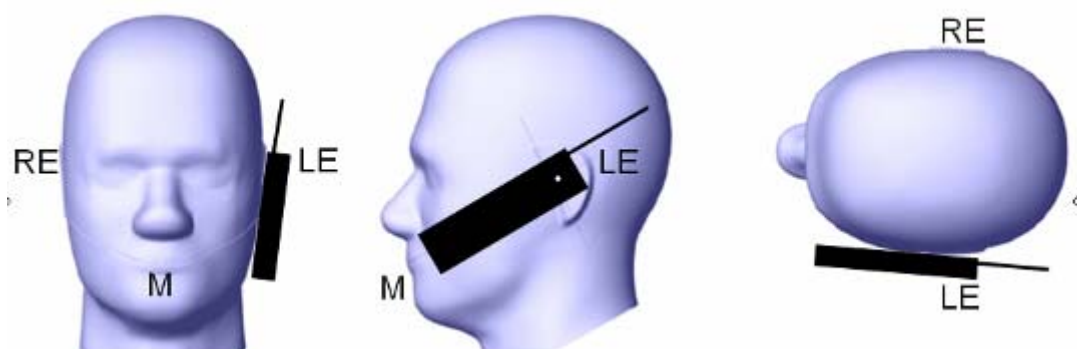

Ear/Tilt Position

With the handset aligned in the “Cheek/Touch Position”:

1) If the earpiece of the handset is not in full contact with the phantom’s ear spacer (in the “Cheek/Touch position”) and the peak SAR location for the “Cheek/Touch” position is located at the ear spacer region or corresponds to the earpiece region of the handset, the device should be returned to the “initial ear position” by rotating it away from the mouth until the earpiece is in full contact with the ear spacer.

2) (otherwise) The handset should be moved (translated) away from the cheek perpendicular to the line passes through both “ear reference points” (note: one of these ear reference points may not physically exist on a split head model) for approximate 2-3 cm. While it is in this position, the device handset is tilted away from the mouth with respect to the “test device reference point” until the inside angle between the vertical centerline on the front surface of the phone and the horizontal line passing through the ear reference point is by 15 80°. After the tilt, it is then moved (translated) back toward the head perpendicular to the line passes through both “ear reference points” until the device touches the phantom or the ear spacer. If the antenna touches the head first, the positioning process should be repeated with a tilt angle less than 15° so that the device and its antenna would touch the phantom simultaneously. This test position may require a device holder or positioner to achieve the translation and tilting with acceptable positioning repeatability.

If a device is also designed to transmit with its keypad cover closed for operating in the head position, such positions should also be considered in the SAR evaluation. The device should be tested on the left and right side of the head phantom in the “Cheek/Touch” and “Ear/Tilt” positions. When applicable, each configuration should be tested with the antenna in its fully extended and fully retracted positions. These test configurations should be tested at the high, middle and low frequency channels of each operating mode; for example, AMPS, CDMA, and TDMA. If the SAR measured at the middle channel for each test configuration (left, right, Cheek/Touch, Tilt/Ear, extended and retracted) is at least 2.0 dB lower than the SAR limit, testing at the high and low channels is optional for such test configuration(s). If the transmission band of the test device is less than 10 MHz, testing at the high and low frequency channels is optional.

Ear /Tilt 15° Position

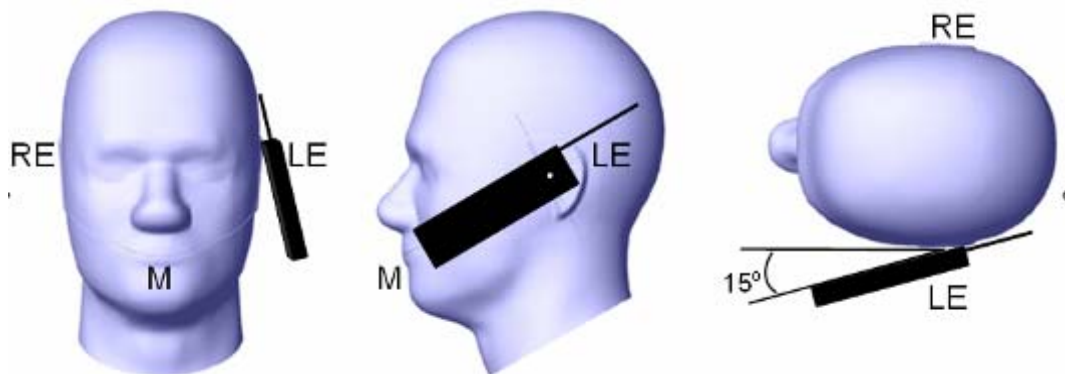

Test positions for body-worn and other configurations

Body-worn operating configurations should be tested with the belt-clips and holsters attached to the device and positioned against a flat phantom in normal use configurations. Devices with a headset output should be tested with a headset connected to the device. When multiple accessories that do not contain metallic components are supplied with the device, the device may be tested with only the accessory that dictates the closest spacing to the body. When multiple accessories that contain metallic components are supplied with the device, the device must be tested with each accessory that contains a unique metallic component. If multiple accessories share an identical metallic component (e.g., the same metallic belt-clip used with different holsters with no other metallic components), only the accessory that dictates the closest spacing to the body must be tested.

Body-worn accessories may not always be supplied or available as options for some devices that are intended to be authorized for body-worn use. A separation distance of 1.5 cm between the back of the device and a flat phantom is recommended for testing body-worn SAR compliance under such circumstances. Other separation distances may be used, but they should not exceed 2.5 cm. In these cases, the device may use body-worn accessories that provide a separation distance greater than that tested for the device provided however that the accessory contains no metallic components.

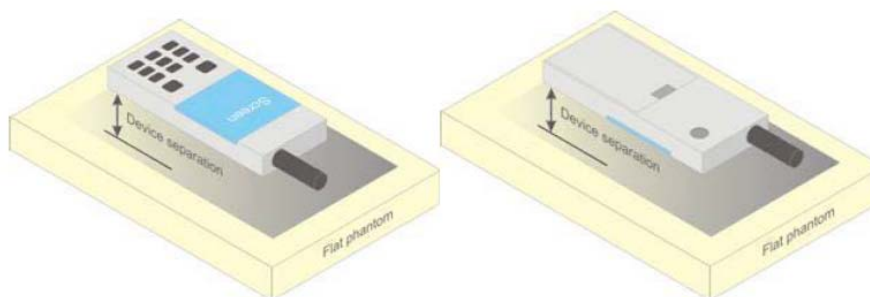

Figure 5 – Test positions for body-worn devices

SAR Evaluation Procedure

The evaluation was performed with the following procedure:

Step 1: Measurement of the SAR value at a fixed location above the ear point or central position was used as a reference value for assessing the power drop. The SAR at this point is measured at the start of the test and then again at the end of the testing.

Step 2: The SAR distribution at the exposed side of the head was measured at a distance of 4 mm from the inner surface of the shell. The area covered the entire dimension of the head or EUT and the horizontal grid spacing was 10 mm x 10 mm. Based on these data, the area of the maximum absorption was determined by spline interpolation. The first Area Scan covers the entire dimension of the EUT to ensure that the hotspot was correctly identified.

Step 3: Around this point, a volume of 35 mm x 35 mm x 35 mm was assessed by measuring 7x 7 x 7 points. On the basis of this data set, the spatial peak SAR value was evaluated under the following procedure:

- 1) The data at the surface were extrapolated, since the center of the dipoles is 1.2 mm away from the tip of the probe and the distance between the surface and the lowest measuring point is 1.3 mm. The extrapolation was based on a least square algorithm. A polynomial of the fourth order was calculated through the points in z-axes. This polynomial was then used to evaluate the points between the surface and the probe tip.
- 2) The maximum interpolated value was searched with a straightforward algorithm. Around this maximum the SAR values averaged over the spatial volumes (1 g or 10 g) were computed by the 3D-Spline interpolation algorithm. The 3D-Spline is composed of three one dimensional splines with the "Not a knot"-condition (in x, y and z-directions). The volume was integrated with the trapezoidal-algorithm. One thousand points (10 x 10 x 10) were interpolated to calculate the averages.

All neighboring volumes were evaluated until no neighboring volume with a higher average value was found.

Step 4: Re-measurement of the SAR value at the same location as in Step 1. If the value changed by more than 5%, the evaluation was repeated.

Test methodology

KDB 447498 D01 General RF Exposure Guidance v05r02.
KDB 648474 D04 Handset SAR v01r02.
KDB 865664 D01 SAR measurement 100 MHz to 6 GHz v01r03
KDB 865664 D02 RF Exposure Reporting v01r01
KDB 941225 D01 3G SAR Procedures v03
KDB 941225 D05 SAR for LTE Devices v02r03
KDB 941225 D06 Hotspot Mode v02

CONDUCTED OUTPUT POWER MEASUREMENT

Provision Applicable

The measured peak output power should be greater and within 5% than EMI measurement.

Test Procedure

The RF output of the transmitter was connected to the input of the EMI Test Receiver through sufficient attenuation.

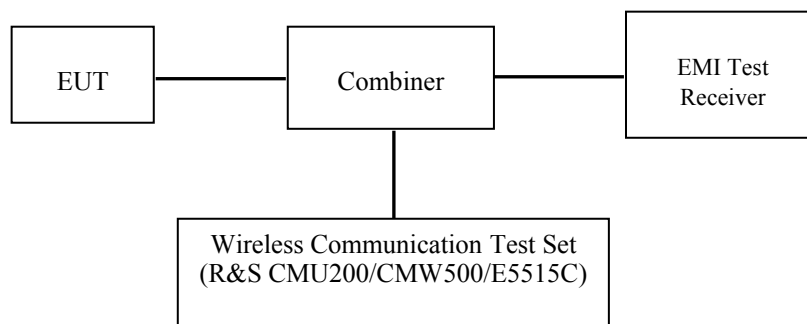

GSM/WCDMA/LTE

Radio Configuration

The power measurement was configured by the Wireless Communication Test Set CMU200 & CMW500 for all Radio configurations except the HSPA+/DC-HSDPA configured by E5515C.

GSM

Function: Menu select > GSM Mobile Station > GSM 850/1900

Press Connection control to choose the different menus

Press RESET > choose all the reset all settings

Connection: Press Signal Off to turn off the signal and change settings

Network Support > GSM + only

MS Signal

> 33 dBm for GSM 850

> 30 dBm for PCS 1900

BS Signal: Enter the same channel number for TCH channel (test channel) and BCCH channel

Frequency Offset >+ 0 Hz

Mode > BCCH and TCH

BCCH Level > -85 dBm (May need to adjust if link is not stable)

BCCH Channel > choose desired test channel [Enter the same channel number for TCH channel (test channel) and BCCH channel]

Channel Type > Off

P0 > 4 dB

TCH > choose desired test channel

Hopping > Off

AF/RF: Enter appropriate offsets for Ext. Att. Output and Ext. Att. Input

Connection: Press Signal on to turn on the signal and change settings

GPRS

Function: Menu select > GSM Mobile Station > GSM 850/1900
 Press Connection control to choose the different menus
 Press RESET > choose all the reset all settings
 Connection: Press Signal Off to turn off the signal and change settings
 Network Support > GSM + GPRS or GSM + EGSM
 Main Service > Packet Data

Service selection > Test Mode A – Auto Slot Config. off
 MS Signal: Press Slot Config Bottom on the right twice to select and change the number of time slots and power setting
 > Slot configuration > Uplink/Gamma
 > 33 dBm for GPRS 850
 > 30 dBm for GPRS 1900

BS Signal: Enter the same channel number for TCH channel (test channel) and BCCH channel
 Frequency Offset >+ 0 Hz
 Mode >BCCH and TCH
 BCCH Level >-85 dBm (May need to adjust if link is not stable)
 BCCH Channel > choose desire test channel [Enter the same channel number for TCH channel (test channel) and BCCH channel]

Channel Type > Off
 P0 > 4 dB
 Slot Config > Unchanged (if already set under MS signal)
 TCH > choose desired test channel
 Hopping >Off
 Main Timeslot >3
 Network: Coding Scheme >CS4 (GPRS)
 Bit Stream >2E9-1 PSR Bit Stream
 AF/RF: Enter appropriate offsets for Ext. Att. Output and Ext. Att. Input
 Connection: Press Signal on to turn on the signal and change settings

WCDMA Release 99

The following tests were conducted according to the test requirements outlines in section 5.2 of the 3GPP TS34.121-1 specification. The EUT has a nominal maximum output power of 24dBm (+1.7/-3.7).

WCDMA General Settings	Loopback Mode	Test Mode 1
	Rel99 RMC	12.2kbps RMC
	Power Control Algorithm	Algorithm2
	$\beta c / \beta d$	8/15

HSDPA

The following tests were conducted according to the test requirements outlines in section 5.2 of the 3GPP TS34.121-1 specification.

	Mode Subset	HSDPA 1	HSDPA 2	HSDPA 3	HSDPA 4
WCDMA General Settings	Loopback Mode	Test Mode 1			
	Rel99 RMC	12.2kbps RMC			
	HSDPA FRC	H-Set1			
	Power Control Algorithm	Algorithm2			
	βc	2/15	12/15	15/15	15/15
	βd	15/15	15/15	8/15	4/15
	βd (SF)	64			
	$\beta c / \beta d$	2/15	12/15	15/8	15/4
	βhs	4/15	24/15	30/15	30/15
MPR(dB)	0	0	0.5	0.5	
HSDPA Specific Settings	DACK	8			
	DNAK	8			
	DCQI	8			
	Ack-Nack repetition factor	3			
	CQI Feedback	4ms			
	CQI Repetition Factor	2			
	$Ahs = \beta hs / \beta c$	30/15			

HSUPA

The following tests were conducted according to the test requirements outlines in section 5.2 of the 3GPP TS34.121-1 specification.

	Mode	HSUPA	HSUPA	HSUPA	HSUPA	HSUPA
	Subset	1	2	3	4	5
WCDMA A General Settings	Loopback Mode	Test Mode 1				
	Rel99 RMC	12.2kbps RMC				
	HSDPA FRC	H-Set1				
	HSUPA Test	HSUPA Loopback				
	Power Control Algorithm	Algorithm2				
	βc	11/15	6/15	15/15	2/15	15/15
	βd	15/15	15/15	9/15	15/15	0
	βec	209/225	12/15	30/15	2/15	5/15
	$\beta c/ \beta d$	11/15	6/15	15/9	2/15	-
	βhs	22/15	12/15	30/15	4/15	5/15
	CM(dB)	1.0	3.0	2.0	3.0	1.0
MPR(dB)	0	2	1	2	0	
HSDPA Specific Settings	DACK	8				
	DNAK	8				
	DCQI	8				
	Ack-Nack repetition factor	3				
	CQI Feedback	4ms				
	CQI Repetition Factor	2				
	$A_{hs} = \beta_{hs} / \beta c$	30/15				
HSUPA Specific Settings	DE-DPCCH	6	8	8	5	7
	DHARQ	0	0	0	0	0
	AG Index	20	12	15	17	21
	ETFCI	75	67	92	71	81
	Associated Max UL Data Rate kbps	242.1	174.9	482.8	205.8	308.9
	Reference E_FCI	E-TFCI 11 E E-TFCI PO 4 E-TFCI 67 E-TFCI PO 18 E-TFCI 71 E-TFCI PO23 E-TFCI 75 E-TFCI PO26 E-TFCI 81 E-TFCI PO 27	E-TFCI 11 E-TFCI PO4 E-TFCI 92 E-TFCI PO 18	E-TFCI 11 E E-TFCI PO 4 E-TFCI 67 E-TFCI PO 18 E-TFCI 71 E-TFCI PO23 E-TFCI 75 E-TFCI PO26 E-TFCI 81 E-TFCI PO 27		

HSPA+

The following tests were conducted according to the test requirements in Table C.11.1.4 of 3GPP TS 34.121-1

Sub-test	β_c (Note3)	β_d	β_{HS} (Note1)	β_{ec}	β_{ed} (2xSF2) (Note 4)	β_{ed} (2xSF4) (Note 4)	CM (dB) (Note 2)	MPR (dB) (Note 2)	AG Index (Note 4)	E-TFCI (Note 5)	E-TFCI (boost)
1	1	0	30/15	30/15	β_{ed1} : 30/15 β_{ed2} : 30/15	β_{ed3} : 24/15 β_{ed4} : 24/15	3.5	2.5	14	105	105

- Note 1: $\Delta_{ACK}, \Delta_{NACK}$ and $\Delta_{CQI} = 30/15$ with $\beta_{hs} = 30/15 * \beta_c$.
- Note 2: CM = 3.5 and the MPR is based on the relative CM difference, MPR = MAX(CM-1,0).
- Note 3: DPDCH is not configured, therefore the β_c is set to 1 and $\beta_d = 0$ by default.
- Note 4: β_{ed} can not be set directly; it is set by Absolute Grant Value.
- Note 5: All the sub-tests require the UE to transmit 2SF2+2SF4 16QAM EDCH and they apply for UE using E-DPDCH category 7. E-DCH TTI is set to 2ms TTI and E-DCH table index = 2. To support these E-DCH configurations DPDCH is not allocated. The UE is signalled to use the extrapolation algorithm.

DC-HSDPA

The following tests were conducted according to the test requirements in Table Table C.8.1.12 of 3GPP TS 34.121-1

Table C.8.1.12: Fixed Reference Channel H-Set 12

Parameter	Unit	Value
Nominal Avg. Inf. Bit Rate	kbps	60
Inter-TTI Distance	TTI's	1
Number of HARQ Processes	Processes	6
Information Bit Payload (N_{INF})	Bits	120
Number Code Blocks	Blocks	1
Binary Channel Bits Per TTI	Bits	960
Total Available SML's in UE	SML's	19200
Number of SML's per HARQ Proc.	SML's	3200
Coding Rate		0.15
Number of Physical Channel Codes	Codes	1
Modulation		QPSK
<p>Note 1: The RMC is intended to be used for DC-HSDPA mode and both cells shall transmit with identical parameters as listed in the table.</p> <p>Note 2: Maximum number of transmission is limited to 1, i.e., retransmission is not allowed. The redundancy and constellation version 0 shall be used.</p>		

LTE

For UE Power Class 1 and 3, the allowed Maximum Power Reduction (MPR) for the maximum output power in Table 6.2.2-1 due to higher order modulation and transmit bandwidth configuration (resource blocks) is specified in Table 6.2.3-1.

Table 6.2.3-1: Maximum Power Reduction (MPR) for Power Class 1 and 3

Modulation	Channel bandwidth / Transmission bandwidth (N_{RB})						MPR (dB)
	1.4 MHz	3.0 MHz	5 MHz	10 MHz	15 MHz	20 MHz	
QPSK	> 5	> 4	> 8	> 12	> 16	> 18	≤ 1
16 QAM	≤ 5	≤ 4	≤ 8	≤ 12	≤ 16	≤ 18	≤ 1
16 QAM	> 5	> 4	> 8	> 12	> 16	> 18	≤ 2

For UE Power Class 1 and 3 the specific requirements and identified subclauses are specified in Table 6.2.4-1 along with the allowed A-MPR values that may be used to meet these requirements. The allowed A-MPR values specified below in Table 6.2.4.-1 to 6.2.4-15 are in addition to the allowed MPR requirements specified in subclause 6.2.3.

Table 6.2.4-1: Additional Maximum Power Reduction (A-MPR)

Network Signalling value	Requirements (subclause)	E-UTRA Band	Channel bandwidth (MHz)	Resources Blocks (N_{RB})	A-MPR (dB)
NS_01	6.6.2.1.1	Table 5.5-1	1.4, 3, 5, 10, 15, 20	Table 5.6-1	N/A
NS_03	6.6.2.2.1	2, 4, 10, 23, 25, 35, 36	3	>5	≤ 1
			5	>6	≤ 1
			10	>6	≤ 1
			15	>8	≤ 1
NS_04	6.6.2.2.2	41	20	>10	≤ 1
			5	>6	≤ 1
NS_05	6.6.3.3.1	1	10, 15, 20	≥ 50	≤ 1
NS_06	6.6.2.2.3	12, 13, 14, 17	1.4, 3, 5, 10	Table 5.6-1	N/A
NS_07	6.6.2.2.3 6.6.3.3.2	13	10	Table 6.2.4-2	
NS_08	6.6.3.3.3	19	10, 15	> 44	≤ 3
NS_09	6.6.3.3.4	21	10, 15	> 40	≤ 1
				> 55	≤ 2
NS_10		20	15, 20	Table 6.2.4-3	
NS_11	6.6.2.2.1	23	1.4, 3, 5, 10, 15, 20	Table 6.2.4-5	
NS_12	6.6.3.3.5	26	1.4, 3, 5	Table 6.2.4-6	
NS_13	6.6.3.3.6	26	5	Table 6.2.4-7	
NS_14	6.6.3.3.7	26	10, 15	Table 6.2.4-8	
NS_15	6.6.3.3.8	26	1.4, 3, 5, 10, 15	Table 6.2.4-9 Table 6.2.4-10	
NS_16	6.6.3.3.9	27	3, 5, 10	Table 6.2.4-11, Table 6.2.4-12, Table 6.2.4-13	
NS_17	6.6.3.3.10	28	5, 10	Table 5.6-1	N/A
NS_18	6.6.3.3.11	28	5	≥ 2	≤ 1
			10, 15, 20	≥ 1	≤ 4
NS_19	6.6.3.3.12	44	10, 15, 20	Table 6.2.4-14	
NS_20	6.2.2 6.6.2.2.1 6.6.3.2	23	5, 10, 15, 20	Table 6.2.4-15	
...					
NS_32	-	-	-	-	-

Maximum Output Power among production units

Max Target Power for Production Unit (dBm)			
Mode/Band	Channel		
	Low	Middle	High
GSM 850	32.80	32.80	32.80
GPRS 1 TX Slot	32.70	32.70	32.70
GPRS 2 TX Slot	32.20	32.20	32.20
GPRS 3 TX Slot	30.40	30.40	30.40
GPRS 4 TX Slot	29.40	29.40	29.40
EDGE 1 TX Slot	27.00	27.00	27.00
EDGE 2 TX Slot	25.30	25.30	25.30
EDGE 3 TX Slot	23.00	23.00	23.00
EDGE 4 TX Slot	22.10	22.10	22.10
PCS 1900	28.50	28.50	28.50
GPRS 1 TX Slot	28.40	28.40	28.40
GPRS 2 TX Slot	27.80	27.80	27.80
GPRS 3 TX Slot	25.90	25.90	25.90
GPRS 4 TX Slot	24.90	24.90	24.90
EDGE 1 TX Slot	25.50	25.50	25.50
EDGE 2 TX Slot	24.20	24.20	24.20
EDGE 3 TX Slot	22.40	22.40	22.40
EDGE 4 TX Slot	21.10	21.10	21.10
WCDMA 850	RMC	22.80	22.80
	HSDPA	22.10	22.10
	HSUPA	22.00	22.00
	DC-HSDPA	21.40	21.40
	HSPA+	21.40	21.40
WCDMA 1700	RMC	22.90	22.90
	HSDPA	22.10	22.10
	HSUPA	22.20	22.20
	DC-HSDPA	21.60	21.60
	HSPA+	21.70	21.70
WCDMA 1900	RMC	23.00	23.00
	HSDPA	22.30	22.30
	HSUPA	22.40	22.40
	DC-HSDPA	21.80	21.80
	HSPA+	21.80	21.80
LTE Band 2	23.30	23.30	23.30
LTE Band 4	23.00	23.00	23.00
Wi-Fi(b/g/n20)	9.50	9.50	9.50
Wi-Fi(n40)	9.00	9.00	9.00
Bluetooth	7.10	7.10	7.10
BLE	-3.00	-3.00	-3.00

Test Results:

GSM:

Band	Channel No.	Frequency (MHz)	Conducted Output Power	
			Meas. Power (dBm)	Meas. Power (W)
GSM 850	128	824.2	32.76	1.888
	190	836.6	32.69	1.858
	251	848.8	32.42	1.746
PCS 1900	512	1850.2	28.45	0.700
	661	1880.0	28.29	0.675
	810	1909.8	28.39	0.690

GPRS:

Band	Channel No.	Frequency (MHz)	RF Output Power (dBm)			
			1 slot	2 slot	3 slots	4 slots
GSM 850	128	824.2	32.67	32.14	30.37	29.23
	190	836.6	32.55	32.00	30.35	29.33
	251	848.8	32.43	31.98	30.26	29.20
PCS 1900	512	1850.2	28.34	27.47	25.78	24.57
	661	1880.0	28.28	27.54	25.74	24.70
	810	1909.8	28.32	27.72	25.85	24.82

EGPRS:

Band	Channel No.	Frequency (MHz)	RF Output Power (dBm)			
			1 slot	2 slot	3 slots	4 slots
GSM 850	128	824.2	26.89	24.86	22.95	22.04
	190	836.6	26.90	25.11	22.97	21.76
	251	848.8	26.83	25.20	22.81	21.87
PCS 1900	512	1850.2	25.49	23.83	21.81	20.91
	661	1880.0	25.48	24.10	22.31	20.74
	810	1909.8	25.32	23.91	22.08	21.07

For SAR, the time based average power is relevant, the difference in between depends on the duty cycle of the TDMA signal.

Number of Time slot	1	2	3	4
Duty Cycle	1:8	1:4	1:2.66	1:2
Time based Ave. power compared to slotted Ave. power	-9 dB	-6 dB	-4.25 dB	-3 dB
Crest Factor	8	4	2.66	2

The time based average power for GPRS

Band	Channel No.	Frequency (MHz)	Time based average Power (dBm)			
			1 slot	2 slot	3 slots	4 slots
GSM 850	128	824.2	23.67	26.14	26.12	26.23
	190	836.6	23.55	26.00	26.10	26.33
	251	848.8	23.43	25.98	26.01	26.20
PCS 1900	512	1850.2	19.34	21.47	21.53	21.57
	661	1880.0	19.28	21.54	21.49	21.70
	810	1909.8	19.32	21.72	21.60	21.82

The time based average power for EGPRS

Band	Channel No.	Frequency (MHz)	Time based average Power (dBm)			
			1 slot	2 slot	3 slots	4 slots
GSM 850	128	824.2	17.89	18.86	18.70	19.04
	190	836.6	17.90	19.11	18.72	18.76
	251	848.8	17.83	19.20	18.56	18.87
PCS 1900	512	1850.2	16.49	17.83	17.56	17.91
	661	1880.0	16.48	18.10	18.06	17.74
	810	1909.8	16.32	17.91	17.83	18.07

Note:

1. Rohde & Schwarz Radio Communication Tester (CMU200) was used for the measurement of GSM peak and average output power for active timeslots.
2. For GSM voice, 1 timeslot has been activated with power level 5 (850 MHz band) and 0 (1900 MHz band).
3. For GPRS, 1, 2, 3 and 4 timeslots has been activated separately with power level 3(850 MHz band) and 3(1900 MHz band).
4. For EGPRS, 1, 2, 3 and 4 timeslots has been activated separately with power level 6(850 MHz band) and 5(1900 MHz band).
5. According to KDB941225D01-SAR for GPRS and EDGE modes are not required when the source-based time-averaged output power for each data mode is lower than that in the normal GSM voice mode

WCDMA 850

Test Condition	Test Mode	3GPP Sub Test	Averaged Mean Power (dBm)		
			Low Frequency	Mid Frequency	High Frequency
Normal	RMC12.2k		22.72	22.17	22.61
	HSDPA	1	21.84	21.24	21.70
		2	22.03	21.34	21.81
		3	21.69	21.11	21.83
		4	21.94	20.95	21.75
	HSUPA	1	21.73	21.20	21.57
		2	21.90	20.96	21.71
		3	21.69	21.04	21.90
		4	21.77	20.98	21.61
		5	21.77	21.35	21.84
	DC-HSDPA	1	21.27	20.69	21.15
		2	21.26	20.75	21.20
		3	21.18	20.82	21.36
		4	21.25	20.76	21.23
	HSPA+	1	21.20	20.75	21.37

WCDMA 1700

Test Condition	Test Mode	3GPP Sub Test	Averaged Mean Power (dBm)		
			Low Frequency	Mid Frequency	High Frequency
Normal	RMC12.2k		22.51	22.67	22.84
	HSDPA	1	21.58	21.86	22.02
		2	21.49	22.08	21.92
		3	21.57	21.99	22.03
		4	21.49	22.01	22.07
	HSUPA	1	21.51	21.87	22.08
		2	21.67	21.84	22.19
		3	21.60	21.80	22.04
		4	21.59	21.98	22.08
		5	21.50	21.94	22.14
	DC-HSDPA	1	21.1	21.45	21.52
		2	20.97	21.33	21.55
		3	21.02	21.53	21.48
		4	21.08	21.44	21.50
		HSPA+	1	20.97	21.37

WCDMA 1900

Test Condition	Test Mode	3GPP Sub Test	Averaged Mean Power (dBm)		
			Low Frequency	Mid Frequency	High Frequency
Normal	RMC12.2k		22.44	22.82	22.96
	HSDPA	1	21.77	22.02	22.14
		2	21.67	22.19	22.11
		3	21.73	22.10	22.20
		4	21.69	22.17	22.25
	HSUPA	1	21.69	22.06	22.19
		2	21.79	22.01	22.33
		3	21.76	21.96	22.15
		4	21.74	22.10	22.25
		5	21.70	22.09	22.30
	DC-HSDPA	1	21.21	21.6	21.62
		2	21.17	21.49	21.71
		3	21.13	21.66	21.62
		4	21.23	21.58	21.67
	HSPA+	1	21.12	21.55	21.77

Note:

1. The default test configuration is to measure SAR with an established radio link between the EUT and a communication test set using a 12.2 kbps RMC (reference measurement Channel) Configured in Test Loop Model 1.
2. KDB 941225 D01-Body SAR is not required for HSDPA/HSUPA/DC-HSDPA/HSPA+ when the maximum average output of each RF channel is less than ¼ dB higher than measured 12.2kbps RMC or the maximum SAR for 12.2kbps RMC is < 75% of SAR limit.

LTE Band 2:

BW	Modulation	Resource Block Size& Resource Block Offset	Target MPR	Meas MPR	Ave Tx Power (dBm)		
					Low Channel	Mid Channel	High Channel
					1850.7MHz	1880MHz	1909.3MHz
1.4M	QPSK	RB Size=1, RB Offset=0	0	0	22.66	22.74	22.54
		RB Size=1, RB Offset=2	0	0	22.76	22.73	22.55
		RB Size=1, RB Offset=5	0	0	22.78	22.73	22.48
		RB Size=3, RB Offset=0	1	1	22.29	22.74	21.87
		RB Size=3, RB Offset=1	1	1	22.16	22.63	21.94
		RB Size=3, RB Offset=2	1	1	21.99	22.66	21.94
		RB Size=6, RB Offset=0	1	1	21.32	21.61	21.28
	16QAM	RB Size=1, RB Offset=0	1	1	22.33	22.47	22.02
		RB Size=1, RB Offset=2	1	1	22.55	22.32	21.89
		RB Size=1, RB Offset=5	1	1	22.42	22.47	21.76
		RB Size=3, RB Offset=0	2	2	21.82	22.51	21.43
		RB Size=3, RB Offset=1	2	2	21.57	22.50	21.69
		RB Size=3, RB Offset=2	2	2	21.80	22.42	21.65
		RB Size=6, RB Offset=0	2	2	21.02	20.69	21.07
BW	Modulation	Resource Block Size& Resource Block Offset	Target MPR	Meas MPR	Ave Tx Power (dBm)		
					Low Channel	Mid Channel	High Channel
					1851.5MHz	1880MHz	1908.5MHz
3M	QPSK	RB Size=1, RB Offset=0	0	0	22.48	22.27	22.55
		RB Size=1, RB Offset=7	0	0	22.44	22.48	22.21
		RB Size=1, RB Offset=14	0	0	22.35	22.44	22.05
		RB Size=8, RB Offset=0	1	1	22.05	22.02	21.93
		RB Size=8, RB Offset=4	1	1	21.96	22.04	21.91
		RB Size=8, RB Offset=7	1	1	21.85	21.83	21.77
		RB Size=15, RB Offset=0	1	1	21.03	21.07	20.99
	16QAM	RB Size=1, RB Offset=0	1	1	22.39	21.95	21.90
		RB Size=1, RB Offset=7	1	1	22.43	21.86	21.71
		RB Size=1, RB Offset=14	1	1	22.42	21.79	21.86
		RB Size=8, RB Offset=0	2	2	21.64	21.47	21.46
		RB Size=8, RB Offset=4	2	2	21.94	21.25	21.45
		RB Size=8, RB Offset=7	2	2	21.67	21.61	21.62
		RB Size=15, RB Offset=0	2	2	20.89	20.88	20.70
BW	Modulation	Resource Block Size& Resource Block Offset	Target MPR	Meas MPR	Ave Tx Power (dBm)		
					Low Channel	Mid Channel	High Channel
					1852.5MHz	1880MHz	1907.5MHz
5M	QPSK	RB Size=1, RB Offset=0	0	0	22.91	22.22	22.59
		RB Size=1, RB Offset=12	0	0	22.70	22.08	22.09
		RB Size=1, RB Offset=24	0	0	22.48	20.09	22.22
		RB Size=12, RB Offset=0	1	1	21.56	21.56	21.55
		RB Size=12, RB Offset=6	1	1	21.87	21.37	21.80
		RB Size=12, RB Offset=11	1	1	21.55	21.34	21.56
		RB Size=25, RB Offset=0	1	1	20.93	20.92	20.85
	16QAM	RB Size=1, RB Offset=0	1	1	21.78	21.47	21.84
		RB Size=1, RB Offset=12	1	1	21.85	21.33	21.75

BW	Modulation	Resource Block Size& Resource Block Offset	Target MPR	Meas MPR	Ave Tx Power (dBm)		
					Low Channel	Mid Channel	High Channel
					1855MHz	1880MHz	1905MHz
		RB Size=1, RB Offset=24	1	1	21.19	21.20	21.85
		RB Size=12, RB Offset=0	2	2	21.57	21.31	21.11
		RB Size=12, RB Offset=6	2	2	21.41	21.49	21.19
		RB Size=12, RB Offset=11	2	2	21.40	20.97	21.12
		RB Size=25, RB Offset=0	2	2	20.69	20.68	20.53
10M	QPSK	RB Size=1, RB Offset=0	0	0	22.49	22.14	22.14
		RB Size=1, RB Offset=24	0	0	22.77	22.00	22.10
		RB Size=1, RB Offset=49	0	0	22.33	22.13	22.26
		RB Size=25, RB Offset=0	1	1	21.85	21.54	21.47
		RB Size=25, RB Offset=12	1	1	22.03	21.56	21.68
		RB Size=25, RB Offset=24	1	1	21.86	21.48	21.68
		RB Size=50, RB Offset=0	1	1	21.39	20.90	20.88
	16QAM	RB Size=1, RB Offset=0	1	1	22.31	21.99	21.76
		RB Size=1, RB Offset=24	1	1	22.15	21.92	21.84
		RB Size=1, RB Offset=49	1	1	21.11	21.67	21.67
		RB Size=25, RB Offset=0	2	2	21.67	21.47	21.06
		RB Size=25, RB Offset=12	2	2	21.49	21.55	21.17
		RB Size=25, RB Offset=24	2	2	20.58	20.70	21.09
		RB Size=50, RB Offset=0	2	2	20.55	20.37	20.18
BW	Modulation	Resource Block Size& Resource Block Offset	Target MPR	Meas MPR	Ave Tx Power (dBm)		
					Low Channel	Mid Channel	High Channel
					1857.5MHz	1880MHz	1902.5MHz
15M	QPSK	RB Size=1, RB Offset=0	0	0	22.29	22.33	22.38
		RB Size=1, RB Offset=37	0	0	22.26	22.40	22.37
		RB Size=1, RB Offset=74	0	0	22.13	22.31	22.59
		RB Size=36, RB Offset=0	1	1	21.80	21.82	21.83
		RB Size=36, RB Offset=18	1	1	21.73	21.94	21.83
		RB Size=36, RB Offset=37	1	1	21.51	21.95	22.05
		RB Size=75, RB Offset=0	1	1	21.52	20.80	20.86
	16QAM	RB Size=1, RB Offset=0	1	1	22.14	21.67	21.83
		RB Size=1, RB Offset=37	1	1	22.14	21.41	21.58
		RB Size=1, RB Offset=74	1	1	22.03	21.36	21.73
		RB Size=36, RB Offset=0	2	2	21.43	20.44	20.81
		RB Size=36, RB Offset=18	2	2	21.58	20.86	21.00
		RB Size=36, RB Offset=37	2	2	21.48	20.70	20.91
		RB Size=75, RB Offset=0	2	2	20.70	20.21	20.04
BW	Modulation	Resource Block Size& Resource Block Offset	Target MPR	Meas MPR	Ave Tx Power (dBm)		
					Low Channel	Mid Channel	High Channel
					1860MHz	1880MHz	1900MHz
20M	QPSK	RB Size=1, RB Offset=0	0	0	22.26	21.87	22.08
		RB Size=1, RB Offset=49	0	0	22.39	22.04	22.41
		RB Size=1, RB Offset=99	0	0	22.34	22.25	23.23
		RB Size=50, RB Offset=0	1	1	21.65	21.25	21.86
		RB Size=50, RB Offset=24	1	1	21.49	21.38	22.00
		RB Size=50, RB Offset=49	1	1	22.70	21.63	21.69

16QAM	RB Size=100, RB Offset=0	1	1	21.49	20.82	20.87
	RB Size=1, RB Offset=0	1	1	21.90	21.77	21.92
	RB Size=1, RB Offset=49	1	1	22.10	21.59	21.78
	RB Size=1, RB Offset=99	1	1	21.94	21.60	21.98
	RB Size=50, RB Offset=0	2	2	21.32	20.91	21.01
	RB Size=50, RB Offset=24	2	2	21.25	21.13	21.10
	RB Size=50, RB Offset=49	2	2	21.20	21.06	20.96
	RB Size=100, RB Offset=0	2	2	20.28	20.47	20.45

LTE Band 4:

BW	Modulation	Resource Block Size& Resource Block Offset	Target MPR	Meas MPR	Ave Tx Power (dBm)				
					Low Channel	Mid Channel	High Channel		
					1710.7MHz	1732.5MHz	1754.3MHz		
1.4M	QPSK	RB Size=1, RB Offset=0	0	0	23.02	22.86	22.78		
		RB Size=1, RB Offset=2	0	0	22.98	22.88	22.77		
		RB Size=1, RB Offset=5	0	0	22.75	22.92	22.64		
		RB Size=3, RB Offset=0	1	1	22.22	21.99	22.22		
		RB Size=3, RB Offset=1	1	1	22.31	22.28	21.76		
		RB Size=3, RB Offset=2	1	1	22.14	22.20	22.02		
		RB Size=6, RB Offset=0	1	1	21.65	21.72	21.52		
	16QAM	RB Size=1, RB Offset=0	1	1	22.25	22.31	22.24		
		RB Size=1, RB Offset=2	1	1	22.29	22.20	21.90		
		RB Size=1, RB Offset=5	1	1	22.12	22.47	21.96		
		RB Size=3, RB Offset=0	2	2	21.54	21.28	21.32		
		RB Size=3, RB Offset=1	2	2	21.10	21.15	21.06		
		RB Size=3, RB Offset=2	2	2	21.23	21.42	21.05		
		RB Size=6, RB Offset=0	2	2	21.69	20.59	20.54		
BW	Modulation	Resource Block Size& Resource Block Offset	Target MPR	Meas MPR	Ave Tx Power (dBm)				
3M	QPSK	RB Size=1, RB Offset=0	0	0	22.78	22.90	22.52		
		RB Size=1, RB Offset=7	0	0	22.68	22.68	22.50		
		RB Size=1, RB Offset=14	0	0	22.64	22.85	22.69		
		RB Size=8, RB Offset=0	1	1	22.64	22.31	21.72		
		RB Size=8, RB Offset=4	1	1	22.45	22.22	22.03		
		RB Size=8, RB Offset=7	1	1	22.34	22.23	21.88		
		RB Size=15, RB Offset=0	1	1	21.69	21.87	21.30		
	16QAM	RB Size=1, RB Offset=0	1	1	22.27	22.11	22.11		
		RB Size=1, RB Offset=7	1	1	21.94	22.31	22.27		
		RB Size=1, RB Offset=14	1	1	22.13	22.32	22.04		
		RB Size=8, RB Offset=0	2	2	21.31	21.48	20.96		
		RB Size=8, RB Offset=4	2	2	21.35	21.16	20.89		
		RB Size=8, RB Offset=7	2	2	21.36	21.22	20.90		
		RB Size=15, RB Offset=0	2	2	20.48	20.72	20.36		
		BW	Modulation	Resource Block Size& Resource Block Offset	Target MPR	Meas MPR	Ave Tx Power (dBm)		
							Low Channel	Mid Channel	High Channel
							1852.5MHz	1880MHz	1907.5MHz

5M	QPSK	RB Size=1, RB Offset=0	0	0	22.88	22.76	22.59
		RB Size=1, RB Offset=12	0	0	22.91	22.57	22.41
		RB Size=1, RB Offset=24	0	0	22.81	22.60	22.70
		RB Size=12, RB Offset=0	1	1	22.15	22.28	21.86
		RB Size=12, RB Offset=6	1	1	22.40	22.02	22.02
		RB Size=12, RB Offset=11	1	1	22.15	22.10	21.82
		RB Size=25, RB Offset=0	1	1	21.64	21.57	21.27
	16QAM	RB Size=1, RB Offset=0	1	1	22.21	22.17	21.95
		RB Size=1, RB Offset=12	1	1	22.40	22.12	22.04
		RB Size=1, RB Offset=24	1	1	22.37	22.59	21.88
		RB Size=12, RB Offset=0	2	2	21.37	21.30	20.89
		RB Size=12, RB Offset=6	2	2	21.03	21.47	21.02
		RB Size=12, RB Offset=11	2	2	21.17	21.55	20.81
		RB Size=25, RB Offset=0	2	2	20.64	20.80	20.56
BW	Modulation	Resource Block Size& Resource Block Offset	Target MPR	Meas MPR	Ave Tx Power (dBm)		
					Low Channel	Mid Channel	High Channel
					1855MHz	1880MHz	1905MHz
10M	QPSK	RB Size=1, RB Offset=0	0	0	22.78	22.51	21.99
		RB Size=1, RB Offset=24	0	0	22.81	22.90	22.19
		RB Size=1, RB Offset=49	0	0	22.79	22.62	21.90
		RB Size=25, RB Offset=0	1	1	22.02	22.27	21.56
		RB Size=25, RB Offset=12	1	1	22.28	22.39	21.70
		RB Size=25, RB Offset=24	1	1	22.05	22.38	21.66
		RB Size=50, RB Offset=0	1	1	21.61	21.56	21.10
	16QAM	RB Size=1, RB Offset=0	1	1	22.43	22.05	21.94
		RB Size=1, RB Offset=24	1	1	22.23	21.93	21.75
		RB Size=1, RB Offset=49	1	1	22.18	22.10	21.93
		RB Size=25, RB Offset=0	2	2	21.38	21.66	21.17
		RB Size=25, RB Offset=12	2	2	21.61	21.63	21.27
		RB Size=25, RB Offset=24	2	2	21.59	21.78	21.41
		RB Size=50, RB Offset=0	2	2	20.26	20.70	20.51
BW	Modulation	Resource Block Size& Resource Block Offset	Target MPR	Meas MPR	Ave Tx Power (dBm)		
					Low Channel	Mid Channel	High Channel
					1857.5MHz	1880MHz	1902.5MHz
15M	QPSK	RB Size=1, RB Offset=0	0	0	23.05	23.13	22.18
		RB Size=1, RB Offset=37	0	0	23.08	23.15	22.34
		RB Size=1, RB Offset=74	0	0	23.11	23.03	22.53
		RB Size=36, RB Offset=0	1	1	22.18	22.29	21.30
		RB Size=36, RB Offset=18	1	1	22.38	22.12	21.19
		RB Size=36, RB Offset=37	1	1	22.49	22.19	21.41
		RB Size=75, RB Offset=0	1	1	21.72	21.61	20.89
	16QAM	RB Size=1, RB Offset=0	1	1	22.24	21.88	22.06
		RB Size=1, RB Offset=37	1	1	22.36	22.20	21.86
		RB Size=1, RB Offset=74	1	1	22.18	21.83	21.62
		RB Size=36, RB Offset=0	2	2	21.27	21.44	21.33
		RB Size=36, RB Offset=18	2	2	21.20	21.45	21.13
		RB Size=36, RB Offset=37	2	2	21.12	21.52	21.12
		RB Size=75, RB Offset=0	2	2	20.24	20.85	20.55
BW	Modulation	Resource Block Size&	Target	Meas	Ave Tx Power (dBm)		

		Resource Block Offset	MPR	MPR	Low Channel	Mid Channel	High Channel
					1860MHz	1880MHz	1900MHz
20M	QPSK	RB Size=1, RB Offset=0	0	0	22.67	22.92	22.22
		RB Size=1, RB Offset=49	0	0	22.82	22.98	22.19
		RB Size=1, RB Offset=99	0	0	22.93	22.95	22.32
		RB Size=50, RB Offset=0	1	1	22.52	22.29	21.49
		RB Size=50, RB Offset=24	1	1	22.19	21.86	21.66
		RB Size=50, RB Offset=49	1	1	22.20	21.52	21.70
		RB Size=100, RB Offset=0	1	1	21.61	20.74	20.80
	16QAM	RB Size=1, RB Offset=0	1	1	22.29	21.82	21.70
		RB Size=1, RB Offset=49	1	1	22.25	22.08	21.83
		RB Size=1, RB Offset=99	1	1	22.03	21.94	22.06
		RB Size=50, RB Offset=0	2	2	21.40	21.21	20.86
		RB Size=50, RB Offset=24	2	2	21.22	21.08	20.80
		RB Size=50, RB Offset=49	2	2	21.33	21.12	21.20
		RB Size=100, RB Offset=0	2	2	20.60	20.89	20.12

Note:

1. SAR for LTE band exposure configurations is measured according to the procedures of KDB 941225 D05 SAR for LTE Devices v02.
2. The CMW500 Wideband Radio Communication tester is used for LTE output power measurements and SAR testing. Closed loop power control is used to keep the radio transmitters the max output power during the test.
3. KDB941225D05v02- SAR for higher order modulation is required only when the highest maximum output power for the configuration in the higher order modulation is > ½ dB higher than the same configuration in QPSK or when the reported SAR for the QPSK configuration is > 1.45 W/kg

Bluetooth

Mode	Channel No.	Frequency (MHz)	Conducted Output Power	
			(dBm)	(mw)
BDR(GFSK)	0	2402	2.72	1.871
	20	2422	7.05	5.070
	39	2441	-0.02	0.995
	58	2460	6.09	4.064
	78	2480	3.19	2.084
EDR(4-DQPSK)	0	2402	2.10	1.622
	20	2422	6.20	4.169
	39	2441	-0.68	0.855
	58	2460	4.69	2.944
	78	2480	2.36	1.722
EDR-8DPSK	0	2402	2.22	1.667
	20	2421	6.34	4.305
	39	2441	-0.59	0.873
	58	2462	5.10	3.236
	78	2480	2.72	1.871
BT4.0	0	2402	-3.44	0.453
	19	2440	-5.31	0.294
	39	2480	-3.18	0.481

Wi-Fi

Band	Channel No.	Frequency (MHz)	Conducted Output Power	
			(dBm)	(mw)
802.11b	1	2412	9.10	8.128
	6	2437	9.15	8.222
	11	2462	9.47	8.851
802.11g	1	2412	9.28	8.472
	6	2437	9.11	8.147
	11	2462	8.69	7.396
802.11n HT20	1	2412	8.85	7.674
	6	2437	9.12	8.166
	11	2462	8.86	7.691
802.11n HT40	1	2422	8.99	7.925
	4	2437	8.66	7.345
	7	2452	8.48	7.047

Note:

1. The output power was tested under data rate 1Mbps for 802.11b, 6Mbps for 802.11g, 6.5Mbps for 802.11n HT20, 13.5Mbps for 802.11n HT40.

SAR MEASUREMENT RESULTS

This page summarizes the results of the performed dosimetric evaluation.

SAR Test Data

Environmental Conditions

Temperature:	21-24 °C
Relative Humidity:	50-53 %
ATM Pressure:	1001-1002 mbar

Testing was performed by Wilson Chen on 2015-10-08

GSM 850:

EUT Position	Frequency (MHz)	Test Mode	Power Drift (%)	Max. Meas. Power (dBm)	Max. Rated Power (dBm)	1g SAR (W/Kg)			
						Scaled Factor	Meas. SAR	Scaled SAR	Plot
Left Head Cheek	824.2	GSM	-2.716	32.76	32.80	1.009	0.523	0.528	1#
	836.6	GSM	3.676	32.69	32.80	1.026	0.502	0.515	/
	848.8	GSM	-0.423	32.42	32.80	1.091	0.474	0.517	/
Left Head Tilt	824.2	GSM	/	/	/	/	/	/	/
	836.6	GSM	4.645	32.69	32.80	1.026	0.250	0.256	/
	848.8	GSM	/	/	/	/	/	/	/
Right Head Cheek	824.2	GSM	/	/	/	/	/	/	/
	836.6	GSM	-1.815	32.69	32.80	1.026	0.504	0.517	/
	848.8	GSM	/	/	/	/	/	/	/
Right Head Tilt	824.2	GSM	/	/	/	/	/	/	/
	836.6	GSM	-0.296	32.69	32.80	1.026	0.247	0.253	/
	848.8	GSM	/	/	/	/	/	/	/
Body-Back-Headset (10mm)	824.2	GSM	/	/	/	/	/	/	/
	836.6	GSM	1.961	32.69	32.80	1.026	0.536	0.550	/
	848.8	GSM	/	/	/	/	/	/	/

Note:

1. When the 1-g SAR is ≤ 0.8 W/Kg, testing for other channels are optional.
2. The EUT transmit and receive through the same GSM antenna while testing SAR.
3. When SAR or MPE is not measured at the maximum power level allowed for production units, the results must be scaled to the maximum tune-up tolerance limit according to the power applied to the individual channels tested to determine compliance.
4. When the maximum output power variation across the required test channels is $> \frac{1}{2}$ dB, instead of the middle channel, the highest output power channel must be used.

PCS Band:

EUT Position	Frequency (MHz)	Test Mode	Power Drift (%)	Max. Meas. Power (dBm)	Max. Rated Power (dBm)	1g SAR (W/Kg)			
						Scaled Factor	Meas. SAR	Scaled SAR	Plot
Left Head Cheek	1850.2	GSM	-0.582	28.45	28.50	1.012	0.412	0.417	2#
	1880	GSM	-2.273	28.29	28.50	1.050	0.381	0.400	/
	1909.8	GSM	1.679	28.39	28.50	1.026	0.394	0.404	/
Left Head Tilt	1850.2	GSM	/	/	/	/	/	/	/
	1880	GSM	-4.315	28.29	28.50	1.050	0.213	0.224	/
	1909.8	GSM	/	/	/	/	/	/	/
Right Head Cheek	1850.2	GSM	/	/	/	/	/	/	/
	1880	GSM	-1.076	28.29	28.50	1.050	0.385	0.404	/
	1909.8	GSM	/	/	/	/	/	/	/
Right Head Tilt	1850.2	GSM	/	/	/	/	/	/	/
	1880	GSM	4.376	28.29	28.50	1.050	0.205	0.215	/
	1909.8	GSM	/	/	/	/	/	/	/
Body-Back-Headset (10mm)	1850.2	GSM	/	/	/	/	/	/	/
	1880	GSM	0.523	28.29	28.50	1.050	0.447	0.469	/
	1909.8	GSM	/	/	/	/	/	/	/

Note:

1. When the 1-g SAR is $\leq 0.8\text{W/Kg}$, testing for other channels are optional.
2. The EUT transmit and receive through the same GSM antenna while testing SAR.
3. When SAR or MPE is not measured at the maximum power level allowed for production units, the results must be scaled to the maximum tune-up tolerance limit according to the power applied to the individual channels tested to determine compliance.
4. When the maximum output power variation across the required test channels is $> \frac{1}{2}$ dB, instead of the middle channel, the highest output power channel must be used.

WCDMA 850 Band:

EUT Position	Frequency (MHz)	Test Mode	Power Drift (%)	Max. Meas. Power (dBm)	Max. Rated Power (dBm)	1g SAR (W/Kg)			
						Scaled Factor	Meas. SAR	Scaled SAR	Plot
Left Head Cheek	826.4	RMC	0.687	22.72	22.80	1.019	0.164	0.167	3#
	836.6	RMC	-1.655	22.17	22.80	1.156	0.123	0.142	/
	846.6	RMC	2.282	22.61	22.80	1.045	0.137	0.143	/
Left Head Tilt	826.4	RMC	/	/	/	/	/	/	/
	836.6	RMC	-1.176	22.17	22.80	1.156	0.096	0.111	/
	846.6	RMC	/	/	/	/	/	/	/
Right Head Cheek	826.4	RMC	/	/	/	/	/	/	/
	836.6	RMC	-3.208	22.17	22.80	1.156	0.120	0.139	/
	846.6	RMC	/	/	/	/	/	/	/
Right Head Tilt	826.4	RMC	/	/	/	/	/	/	/
	836.6	RMC	4.212	22.17	22.80	1.156	0.091	0.105	/
	846.6	RMC	/	/	/	/	/	/	/

WCDMA 1700 Band:

EUT Position	Frequency (MHz)	Test Mode	Power Drift (%)	Max. Meas. Power (dBm)	Max. Rated Power (dBm)	1g SAR (W/Kg)			
						Scaled Factor	Meas. SAR	Scaled SAR	Plot
Left Head Cheek	1712.4	RMC	/	/	/	/	/	/	/
	1732.6	RMC	2.936	22.67	22.90	1.054	0.526	0.555	/
	1752.6	RMC	/	/	/	/	/	/	/
Left Head Tilt	1712.4	RMC	/	/	/	/	/	/	/
	1732.6	RMC	2.516	22.67	22.90	1.054	0.325	0.343	/
	1752.6	RMC	/	/	/	/	/	/	/
Right Head Cheek	1712.4	RMC	0.816	22.51	22.90	1.094	0.493	0.539	/
	1732.6	RMC	-1.711	22.67	22.90	1.054	0.544	0.574	4#
	1752.6	RMC	-2.012	22.84	22.90	1.014	0.556	0.564	/
Right Head Tilt	1712.4	RMC	/	/	/	/	/	/	/
	1732.6	RMC	-2.231	22.67	22.90	1.054	0.333	0.351	/
	1752.6	RMC	/	/	/	/	/	/	/

WCDMA 1900 Band:

EUT Position	Frequency (MHz)	Test Mode	Power Drift (%)	Max. Meas. Power (dBm)	Max. Rated Power (dBm)	1g SAR (W/Kg)			
						Scaled Factor	Meas. SAR	Scaled SAR	Plot
Left Head Cheek	1852.4	RMC	0.664	22.44	23.00	1.138	0.519	0.590	/
	1880	RMC	-2.947	22.82	23.00	1.042	0.554	0.577	/
	1907.6	RMC	3.115	22.96	23.00	1.009	0.587	0.592	5#
Left Head Tilt	1852.4	RMC	/	/	/	/	/	/	/
	1880	RMC	1.849	22.82	23.00	1.042	0.294	0.306	/
	1907.6	RMC	/	/	/	/	/	/	/
Right Head Cheek	1852.4	RMC	/	/	/	/	/	/	/
	1880	RMC	-3.664	22.82	23.00	1.042	0.561	0.585	/
	1907.6	RMC	/	/	/	/	/	/	/
Right Head Tilt	1852.4	RMC	/	/	/	/	/	/	/
	1880	RMC	1.105	22.82	23.00	1.042	0.286	0.298	/
	1907.6	RMC	/	/	/	/	/	/	/

Note:

1. When the 1-g SAR is ≤ 0.8 W/Kg, testing for other channels are optional.
2. The EUT transmit and receive through the same antenna while testing SAR.
3. The default test configuration is to measure SAR with an established radio link between the EUT and a communication test set using a 12.2 kbps RMC (reference measurement Channel) Configured in Test Loop Model.
4. KDB 941225 D01-Body SAR is not required for HSDPA/HSUPA/DC-HSDPA/HSPA+ when the maximum average output of each RF channel is less than $\frac{1}{4}$ dB higher than measured 12.2kbps RMC or the maximum SAR for 12.2kbps RMC is $< 75\%$ of SAR limit.
5. When SAR or MPE is not measured at the maximum power level allowed for production units, the results must be scaled to the maximum tune-up tolerance limit according to the power applied to the individual channels tested to determine compliance.

LTE Band 2:

EUT Position	Frequency (MHz)	Bandwidth (MHz)	Test Mode	Power Drift (%)	Max. Meas. Power (dBm)	Max. Rated Power (dBm)	1g SAR (W/Kg)			
							Scaled Factor	Meas. SAR	Scaled SAR	Plot
Left Head Cheek	1860	20	1RB, Offset=0	/	/	/	/	/	/	/
	1880	20	1RB, Offset=0	/	/	/	/	/	/	/
	1900	20	1RB, Offset=0	-3.071	23.23	23.30	1.016	0.612	0.622	/
	1860	20	50%RB, Offset=49	0.501	22.70	23.30	1.148	0.541	0.621	/
Left Head Tilt	1860	20	1RB, Offset=0	/	/	/	/	/	/	/
	1880	20	1RB, Offset=0	/	/	/	/	/	/	/
	1900	20	1RB, Offset=0	3.822	23.23	23.30	1.016	0.314	0.319	/
	1860	20	50%RB, Offset=49	-1.933	22.70	23.30	1.148	0.270	0.310	/
Right Head Cheek	1860	20	1RB, Offset=0	/	/	/	/	/	/	/
	1880	20	1RB, Offset=0	/	/	/	/	/	/	/
	1900	20	1RB, Offset=0	0.973	23.23	23.30	1.016	0.619	0.629	6#
	1860	20	50%RB, Offset=49	2.880	22.70	23.30	1.148	0.538	0.618	/
Right Head Tilt	1860	20	1RB, Offset=0	/	/	/	/	/	/	/
	1880	20	1RB, Offset=0	/	/	/	/	/	/	/
	1900	20	1RB, Offset=0	0.432	23.23	23.30	1.016	0.306	0.311	/
	1860	20	50%RB, Offset=49	-2.213	22.70	23.30	1.148	0.262	0.301	/

LTE Band 4:

EUT Position	Frequency (MHz)	Bandwidth (MHz)	Test Mode	Power Drift (%)	Max. Meas. Power (dBm)	Max. Rated Power (dBm)	1g SAR (W/Kg)			
							Scaled Factor	Meas. SAR	Scaled SAR	Plot
Left Head Cheek	1720	20	1RB, Offset=0	/	/	/	/	/	/	/
	1732.5	20	1RB, Offset=0	-1.461	22.98	23.00	1.005	0.343	0.345	7#
	1745	20	1RB, Offset=0	/	/	/	/	/	/	/
	1720	20	50%RB, Offset=0	3.092	22.52	23.00	1.117	0.308	0.344	/
Left Head Tilt	1720	20	1RB, Offset=0	/	/	/	/	/	/	/
	1732.5	20	1RB, Offset=0	1.424	22.98	23.00	1.005	0.168	0.169	/
	1745	20	1RB, Offset=0	/	/	/	/	/	/	/
	1720	20	50%RB, Offset=0	1.940	22.52	23.00	1.117	0.125	0.140	/
Right Head Cheek	1720	20	1RB, Offset=0	/	/	/	/	/	/	/
	1732.5	20	1RB, Offset=0	-3.362	22.98	23.00	1.005	0.339	0.341	/
	1745	20	1RB, Offset=0	/	/	/	/	/	/	/
	1720	20	50%RB, Offset=0	0.476	22.52	23.00	1.117	0.296	0.331	/
Right Head Tilt	1720	20	1RB, Offset=0	/	/	/	/	/	/	/
	1732.5	20	1RB, Offset=0	3.166	22.98	23.00	1.005	0.157	0.158	/
	1745	20	1RB, Offset=0	/	/	/	/	/	/	/
	1720	20	50%RB, Offset=0	-2.230	22.52	23.00	1.117	0.122	0.136	/

Note:

1. When the 1-g SAR is ≤ 0.8 W/Kg, testing for other channels are optional.
2. SAR for LTE band exposure configurations is measured according to the procedures of KDB 941225 D05 SAR for LTE Devices v02.

3. KDB941225D05- SAR for higher order modulation is required only when the highest maximum output power for the configuration in the higher order modulation is > ½ dB higher than the same configuration in QPSK or when the reported SAR for the QPSK configuration is > 1.45 W/kg
4. KDB941225D05- For QPSK with 100% RB allocation, when the reported SAR measured for the Highest output power channel is <1.45 W/kg, tests for the remaining required test channels are optional.
5. KDB941225D05- For QPSK with 100% RB allocation, SAR is not required when the highest maximum output power for 100 % RB allocation is less than the highest maximum output power in 50% and 1 RB allocations and the highest reported SAR for 1 RB and 50% RB allocation are ≤ 0.8 W/kg.
6. KDB941225D05- Start with the largest channel bandwidth (20M) and measure SAR for QPSK with 1 RB allocation, using the RB offset and required test channel combination with the highest maximum output power among RB offset the upper edge, middle and lower edge of each required test channel.
7. Worst case SAR for 50% RB allocation is selected to be tested.

Mobile Hot-Spot Test Result

The DUT is capable of functioning as a Wi-Fi to Cellular Mobile hotspot. Additional SAR testing was performed according to KDB 941225 D06. Testing was performed with a separation of 1cm between the DUT and the flat phantom. The DUT was positioned for SAR tests with the front and back surfaces facing the phantom, and also with the edges facing the phantom in which the transmitting antenna is <2.5 cm from the edge. Each transmit band was utilized for SAR testing. The tested mode has been selected within each band that exhibits the highest time average output power.

Hot spot-GPRS (Frequency Band: 850)

EUT Position	Frequency (MHz)	Test Mode	Power Drift (%)	Max. Meas. Power (dBm)	Max. Rated Power (dBm)	1g SAR (W/Kg)			
						Scaled Factor	Meas. SAR	Scaled SAR	Plot
Body-Back (10mm)	824.2	GPRS	-1.732	29.23	29.40	1.040	1.002	1.042	/
	836.6	GPRS	-0.572	29.33	29.40	1.016	1.027	1.044	8#
	848.8	GPRS	3.067	29.20	29.40	1.047	0.984	1.030	/
Body-Left (10mm)	824.2	GPRS	/	/	/	/	/	/	/
	836.6	GPRS	0.677	29.33	29.40	1.016	0.563	0.572	/
	848.8	GPRS	/	/	/	/	/	/	/
Body-Right (10mm)	824.2	GPRS	/	/	/	/	/	/	/
	836.6	GPRS	0.309	29.33	29.40	1.016	0.682	0.693	/
	848.8	GPRS	/	/	/	/	/	/	/
Body-Bottom (10mm)	824.2	GPRS	/	/	/	/	/	/	/
	836.6	GPRS	-3.305	29.33	29.40	1.016	0.376	0.382	/
	848.8	GPRS	/	/	/	/	/	/	/

Note:

1. When the 1-g SAR is ≤ 0.8W/Kg, testing for other channels are optional.
2. According to IEEE 1528-2013, the middle channel is required to be tested first.
3. KDB 447498D01- When the maximum output power variation across the required test channels is > ½ dB, instead of the middle channel, the highest output power channel must be used.
2. The EUT is a Capability Class B mobile phone which can be attached to both GPRS and GSM services.
3. The Multi-slot Classes of EUT is Class12 which has maximum 4 Downlink slots and 4 Uplink slots, the maximum active slots is 5, when perform the multiple slots scan, 1DL+4UL is the worst case.
4. The EUT transmit and receive through the same GSM antenna while testing SAR.
5. When SAR or MPE is not measured at the maximum power level allowed for production units, the results must be scaled to the maximum tune-up tolerance limit according to the power applied to the individual channels tested to determine compliance.

Hot spot-GPRS (Frequency Band: 1900)

EUT Position	Frequency (MHz)	Test Mode	Power Drift (%)	Max. Meas. Power (dBm)	Max. Rated Power (dBm)	1g SAR (W/Kg)			
						Scaled Factor	Meas. SAR	Scaled SAR	Plot
Body-Back (10mm)	1850.2	GPRS	-0.510	24.57	25.30	1.183	0.738	0.873	/
	1880.0	GPRS	0.167	24.70	25.30	1.148	0.761	0.874	/
	1909.8	GPRS	1.408	24.82	24.90	1.019	0.864	0.880	9#
Body-Left (10mm)	1850.2	GPRS	/	/	/	/	/	/	/
	1880.0	GPRS	/	/	/	/	/	/	/
	1909.8	GPRS	0.870	24.82	24.90	1.019	0.284	0.289	/
Body-Right (10mm)	1850.2	GPRS	/	/	/	/	/	/	/
	1880.0	GPRS	/	/	/	/	/	/	/
	1909.8	GPRS	-2.953	24.82	24.90	1.019	0.318	0.324	/
Body-Bottom (10mm)	1850.2	GPRS	/	/	/	/	/	/	/
	1880.0	GPRS	/	/	/	/	/	/	/
	1909.8	GPRS	-1.101	24.82	24.90	1.019	0.520	0.530	/

Note:

1. When the 1-g SAR is ≤ 0.8 W/Kg, testing for other channels are optional.
2. According to IEEE 1528-2013, the middle channel is required to be tested first.
3. KDB 447498D01- When the maximum output power variation across the required test channels is $> \frac{1}{2}$ dB, instead of the middle channel, the highest output power channel must be used.
4. The EUT is a Capability Class B mobile phone which can be attached to both GPRS and GSM services.
5. The Multi-slot Classes of EUT is Class12 which has maximum 4 Downlink slots and 4 Uplink slots, the maximum active slots is 5, when perform the multiple slots scan, 1DL+4UL is the worst case.
6. The EUT transmit and receive through the same GSM antenna while testing SAR.
7. When SAR or MPE is not measured at the maximum power level allowed for production units, the results must be scaled to the maximum tune-up tolerance limit according to the power applied to the individual channels tested to determine compliance.

Hot Spot-WCDMA 850 Band

EUT Position	Frequency (MHz)	Test Mode	Power Drift (%)	Max. Meas. Power (dBm)	Max. Rated Power (dBm)	1g SAR (W/Kg)			
						Scaled Factor	Meas. SAR	Scaled SAR	Plot
Body-Back (10mm)	826.4	RMC	1.220	22.72	22.80	1.019	0.309	0.315	10#
	836.6	RMC	/	/	/	/	/	/	/
	846.6	RMC	/	/	/	/	/	/	/
Body-Left (10mm)	826.4	RMC	-1.456	22.72	22.80	1.019	0.158	0.161	/
	836.6	RMC	/	/	/	/	/	/	/
	846.6	RMC	/	/	/	/	/	/	/
Body-Right (10mm)	826.4	RMC	1.993	22.72	22.80	1.019	0.174	0.177	/
	836.6	RMC	/	/	/	/	/	/	/
	846.6	RMC	/	/	/	/	/	/	/
Body-Bottom (10mm)	826.4	RMC	-2.916	22.72	22.80	1.019	0.124	0.126	/
	836.6	RMC	/	/	/	/	/	/	/
	846.6	RMC	/	/	/	/	/	/	/

Hot Spot-WCDMA 1700 Band

EUT Position	Frequency (MHz)	Test Mode	Power Drift (%)	Max. Meas. Power (dBm)	Max. Rated Power (dBm)	1g SAR (W/Kg)			
						Scaled Factor	Meas. SAR	Scaled SAR	Plot
Body-Back (10mm)	1712.4	RMC	-0.674	22.51	22.90	1.094	0.927	1.014	/
	1732.6	RMC	2.082	22.67	22.90	1.054	0.980	1.033	/
	1752.6	RMC	-1.644	22.84	22.90	1.014	1.105	1.120	11#
Body-Left (10mm)	1712.4	RMC	/	/	/	/	/	/	/
	1732.6	RMC	/	/	/	/	/	/	/
	1752.6	RMC	-1.581	22.84	22.90	1.014	0.426	0.432	/
Body-Right (10mm)	1712.4	RMC	/	/	/	/	/	/	/
	1732.6	RMC	/	/	/	/	/	/	/
	1752.6	RMC	1.066	22.84	22.90	1.014	0.463	0.469	/
Body-Bottom (10mm)	1712.4	RMC	/	/	/	/	/	/	/
	1732.6	RMC	/	/	/	/	/	/	/
	1752.6	RMC	3.448	22.84	22.90	1.014	0.811	0.822	/

Hot Spot-WCDMA 1900 Band

EUT Position	Frequency (MHz)	Test Mode	Power Drift (%)	Max. Meas. Power (dBm)	Max. Rated Power (dBm)	1g SAR (W/Kg)			
						Scaled Factor	Meas. SAR	Scaled SAR	Plot
Body-Back (10mm)	1852.4	RMC	3.058	22.44	23.00	1.138	0.921	1.048	/
	1880.0	RMC	0.477	22.82	23.00	1.042	0.985	1.027	/
	1907.6	RMC	-1.194	22.96	23.00	1.009	1.283	1.295	12#
Body-Left (10mm)	1852.4	RMC	/	/	/	/	/	/	/
	1880.0	RMC	/	/	/	/	/	/	/
	1907.6	RMC	-0.906	22.82	23.00	1.042	0.353	0.368	/
Body-Right (10mm)	1852.4	RMC	/	/	/	/	/	/	/
	1880.0	RMC	/	/	/	/	/	/	/
	1907.6	RMC	-3.762	22.82	23.00	1.042	0.394	0.411	/
Body-Bottom (10mm)	1852.4	RMC	/	/	/	/	/	/	/
	1880.0	RMC	/	/	/	/	/	/	/
	1907.6	RMC	3.265	22.82	23.00	1.042	0.740	0.771	/

Note:

1. When the 1-g SAR is $\leq 0.8\text{W/Kg}$, testing for other channels are optional.
2. KDB 447498D01- When the maximum output power variation across the required test channels is $> \frac{1}{2}$ dB, instead of the middle channel, the highest output power channel must be used.
3. KDB 941225 D01-Body SAR is not required for HSDPA/HSUPA/DC-HSDPA/HSPA+ when the maximum average output of each RF channel is less than $\frac{1}{4}$ dB higher than measured 12.2kbps RMC or the maximum SAR for 12.2kbps RMC is $< 75\%$ of SAR limit.
4. The default test configuration is to measure SAR with an established radio link between the EUT and a communication test set using a 12.2 kbps RMC (reference measurement Channel) Configured in Test Loop Model.
5. When SAR or MPE is not measured at the maximum power level allowed for production units, the results must be scaled to the maximum tune-up tolerance limit according to the power applied to the individual channels tested to determine compliance.

Hot Spot-LTE Band 2

EUT Position	Frequency (MHz)	Bandwidth (MHz)	Test Mode	Power Drift (%)	Max. Meas. Power (dBm)	Max. Rated Power (dBm)	1g SAR (W/Kg)			
							Scaled Factor	Meas. SAR	Scaled SAR	Plot
Body-Back (10mm)	1860	20	1RB, Offset=0	-1.091	22.34	23.30	1.247	1.027	1.281	/
	1880	20	1RB, Offset=0	0.105	22.25	23.30	1.274	0.993	1.265	/
	1900	20	1RB, Offset=0	-2.475	23.23	23.30	1.016	1.336	1.358	13#
	1860	20	50%RB, Offset=49	-3.925	22.70	23.30	1.148	0.925	1.062	/
Body-Left (10mm)	1860	20	1RB, Offset=0	/	/	/	/	/	/	/
	1880	20	1RB, Offset=0	/	/	/	/	/	/	/
	1900	20	1RB, Offset=0	0.549	23.23	23.30	1.016	0.389	0.395	/
	1860	20	50%RB, Offset=49	-4.601	22.70	23.30	1.148	0.332	0.381	/
Body-Right (10mm)	1860	20	1RB, Offset=0	/	/	/	/	/	/	/
	1880	20	1RB, Offset=0	/	/	/	/	/	/	/
	1900	20	1RB, Offset=0	3.479	23.23	23.30	1.016	0.426	0.433	/
	1860	20	50%RB, Offset=49	-1.666	22.70	23.30	1.148	0.363	0.417	/
Body-Bottom (10mm)	1860	20	1RB, Offset=0	/	/	/	/	/	/	/
	1880	20	1RB, Offset=0	/	/	/	/	/	/	/
	1900	20	1RB, Offset=0	-2.805	23.23	23.30	1.016	0.791	0.804	/
	1860	20	50%RB, Offset=49	1.728	22.70	23.30	1.148	0.716	0.822	/

Hot Spot-LTE Band 4

EUT Position	Frequency (MHz)	Bandwidth (MHz)	Test Mode	Power Drift (%)	Max. Meas. Power (dBm)	Max. Rated Power (dBm)	1g SAR (W/Kg)			
							Scaled Factor	Meas. SAR	Scaled SAR	Plot
Body-Back (10mm)	1720	20	1RB, Offset=0	/	/	/	/	/	/	/
	1732.5	20	1RB, Offset=0	-3.318	22.98	23.00	1.005	0.641	0.644	14#
	1745	20	1RB, Offset=0	/	/	/	/	/	/	/
	1720	20	50%RB, Offset=0	-2.118	22.52	23.00	1.117	0.542	0.605	/
Body-Left (10mm)	1720	20	1RB, Offset=0	/	/	/	/	/	/	/
	1732.5	20	1RB, Offset=0	-0.173	22.98	23.00	1.005	0.267	0.268	/
	1745	20	1RB, Offset=0	/	/	/	/	/	/	/
	1720	20	50%RB, Offset=0	-2.083	22.52	23.00	1.117	0.181	0.202	/
Body-Right (10mm)	1720	20	1RB, Offset=0	/	/	/	/	/	/	/
	1732.5	20	1RB, Offset=0	-1.856	22.98	23.00	1.005	0.302	0.303	/
	1745	20	1RB, Offset=0	/	/	/	/	/	/	/
	1720	20	50%RB, Offset=0	-2.285	22.52	23.00	1.117	0.219	0.245	/
Body-Bottom (10mm)	1720	20	1RB, Offset=0	/	/	/	/	/	/	/
	1732.5	20	1RB, Offset=0	0.241	22.98	23.00	1.005	0.563	0.566	/
	1745	20	1RB, Offset=0	/	/	/	/	/	/	/
	1720	20	50%RB, Offset=0	3.289	22.52	23.00	1.117	0.482	0.538	/

Note:

1. When the 1-g SAR is $\leq 0.8W/Kg$, testing for other channels are optional.

2. SAR for LTE band exposure configurations is measured according to the procedures of KDB 941225 D05 SAR for LTE Devices v02.
3. KDB941225D05- SAR for higher order modulation is required only when the highest maximum output power for the configuration in the higher order modulation is $> \frac{1}{2}$ dB higher than the same configuration in QPSK or when the reported SAR for the QPSK configuration is > 1.45 W/kg
4. KDB941225D05- For QPSK with 100% RB allocation, when the reported SAR measured for the Highest output power channel is < 1.45 W/kg, tests for the remaining required test channels are optional.
5. KDB941225D05- For QPSK with 100% RB allocation, SAR is not required when the highest maximum output power for 100 % RB allocation is less than the highest maximum output power in 50% and 1 RB allocations and the highest reported SAR for 1 RB and 50% RB allocation are ≤ 0.8 W/kg.
6. KDB941225D05- Start with the largest channel bandwidth (20M) and measure SAR for QPSK with 1 RB allocation, using the RB offset and required test channel combination with the highest maximum output power among RB offset the upper edge, middle and lower edge of each required test channel.
7. Worst case SAR for 50% RB allocation is selected to be tested.

SAR SIMULTANEOUS TRANSMISSION DESCRIPTION

BT& Wi-Fi and LTE&GSM&3G Antennas Location:

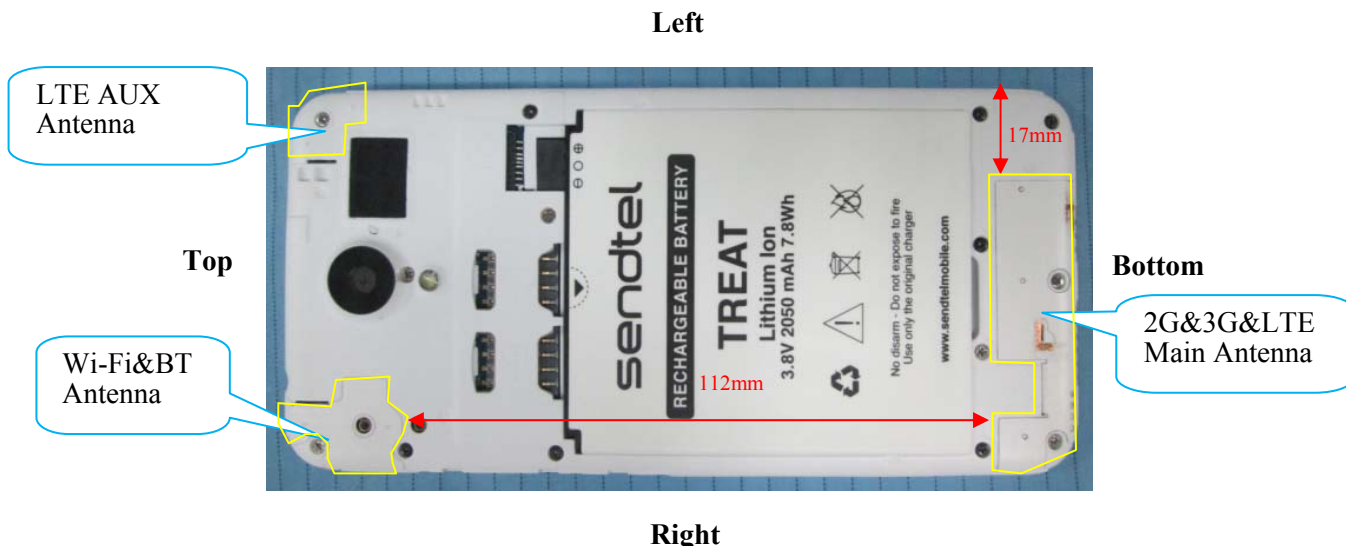

Simultaneous Transmission:

Description of Simultaneous Transmit Capabilities			Antennas Distance (mm)
Transmitter Combination	Simultaneous?	Hotspot?	
GSM + WCDMA	×	×	0
GSM + LTE	×	×	0
GSM + Bluetooth	√	×	112
GSM + Wi-Fi	√	√	112
WCDMA + LTE	×	×	0
WCDMA + Bluetooth	√	×	112
WCDMA + Wi-Fi	√	√	112
LTE+ Bluetooth	√	×	112
LTE+ Wi-Fi	√	√	112

Standalone SAR test exclusion considerations

Head Position:

Mode	Frequency (MHz)	P _{avg} (dBm)	P _{avg} (mW)	Distance (mm)	Calculated value	Threshold (1-g)	SAR Test Exclusion
Wi-Fi	2472	9.50	8.91	0	2.8	3.0	Yes
Bluetooth	2480	7.10	5.13	0	1.6	3.0	Yes

Body Position:

Mode	Frequency (MHz)	P _{avg} (dBm)	P _{avg} (Mw)	Distance (mm)	Calculated value	Threshold (1-g)	SAR Test Exclusion
Wi-Fi	2472	9.50	8.91	10.00	1.4	3.0	Yes
Bluetooth	2480	7.10	5.13	10.00	0.8	3.0	Yes

The 1-g and 10-g SAR test exclusion thresholds for 100 MHz to 6 GHz at *test separation distances* ≤ 50 mm are determined by:

$$[(\text{max. power of channel, including tune-up tolerance, mW})/(\text{min. test separation distance, mm})] \cdot [\sqrt{f(\text{GHz})}] \leq 3.0 \text{ for 1-g SAR and } \leq 7.5 \text{ for 10-g extremity SAR, where}$$

1. f(GHz) is the RF channel transmit frequency in GHz.
2. Power and distance are rounded to the nearest mW and mm before calculation.
3. The result is rounded to one decimal place for comparison.
4. When the minimum test separation distance is < 5 mm, a distance of 5 mm is applied to determine SAR test Exclusion.

Standalone SAR estimation:

Mode	Frequency (GHz)	Distance (mm)	P _{avg} (dBm)	P _{avg} (mW)	Estimated 1-g (W/kg)
BT Head	2.48	0	7.10	5.13	0.215
BT Body	2.48	10	7.10	5.13	0.108
Wi-Fi Head	2.472	0	9.50	8.91	0.374
Wi-Fi Body	2.472	10	9.50	8.91	0.187

When standalone SAR test exclusion applies to an antenna that transmits simultaneously with other antennas, the standalone SAR must be estimated according to following to determine simultaneous transmission SAR test exclusion:

$$[(\text{max. power of channel, including tune-up tolerance, mW})/(\text{min. test separation distance, mm})] \cdot [\sqrt{f(\text{GHz})/x}] \text{ W/kg for test separation distances } \leq 50 \text{ mm;}$$

where $x = 7.5$ for 1-g SAR.

When the minimum test separation distance is < 5 mm, a distance of 5 mm is applied to determine SAR test Exclusion

Simultaneous SAR test exclusion considerations:

GSM with BT:

Mode	Position	Reported SAR (W/kg)		ΣSAR
		GSM	BT	< 1.6W/kg
GSM 850	Left Head Cheek	0.528	0.215	0.743
	Left Head Tilt	0.256	0.215	0.471
	Right Head Cheek	0.517	0.215	0.732
	Right Head Tilt	0.253	0.215	0.468
	Body-Headset-Back	0.550	0.108	0.658
PCS 1900	Left Head Cheek	0.417	0.215	0.632
	Left Head Tilt	0.224	0.215	0.439
	Right Head Cheek	0.404	0.215	0.619
	Right Head Tilt	0.215	0.215	0.430
	Body-Headset-Back	0.469	0.108	0.577

WCDMA with BT:

Mode	Position	Reported SAR (W/kg)		ΣSAR
		WCDMA	BT	< 1.6W/kg
WCDMA 850	Left Head Cheek	0.167	0.215	0.382
	Left Head Tilt	0.111	0.215	0.326
	Right Head Cheek	0.139	0.215	0.354
	Right Head Tilt	0.105	0.215	0.320
WCDMA 1700	Left Head Cheek	0.555	0.215	0.770
	Left Head Tilt	0.343	0.215	0.558
	Right Head Cheek	0.574	0.215	0.789
	Right Head Tilt	0.351	0.215	0.566
WCDMA 1900	Left Head Cheek	0.592	0.215	0.807
	Left Head Tilt	0.306	0.215	0.521
	Right Head Cheek	0.585	0.215	0.800
	Right Head Tilt	0.298	0.215	0.513

LTE with BT:

Mode	Position	Reported SAR (W/kg)		ΣSAR
		LTE	BT	< 1.6W/kg
LTE Band 2	Left Head Cheek	0.622	0.215	0.837
	Left Head Tilt	0.319	0.215	0.534
	Right Head Cheek	0.629	0.215	0.844
	Right Head Tilt	0.311	0.215	0.526
LTE Band 4	Left Head Cheek	0.345	0.215	0.560
	Left Head Tilt	0.169	0.215	0.384
	Right Head Cheek	0.341	0.215	0.556
	Right Head Tilt	0.158	0.215	0.373

GSM with Wi-Fi:

Mode	Position	Reported SAR (W/kg)		ΣSAR
		GSM	Wi-Fi	< 1.6W/kg
GSM 850	Left Head Cheek	0.528	0.372	0.900
	Left Head Tilt	0.256	0.372	0.628
	Right Head Cheek	0.517	0.372	0.889
	Right Head Tilt	0.253	0.372	0.625
	Body-Headset-Back	0.550	0.186	0.736
PCS 1900	Left Head Cheek	0.417	0.372	0.789
	Left Head Tilt	0.224	0.372	0.596
	Right Head Cheek	0.404	0.372	0.776
	Right Head Tilt	0.215	0.372	0.587
	Body-Headset-Back	0.469	0.186	0.655

WCDMA with Wi-Fi:

Mode	Position	Reported SAR (W/kg)		ΣSAR
		WCDMA	Wi-Fi	< 1.6W/kg
WCDMA 850	Left Head Cheek	0.167	0.372	0.539
	Left Head Tilt	0.111	0.372	0.483
	Right Head Cheek	0.139	0.372	0.511
	Right Head Tilt	0.105	0.372	0.477
WCDMA 1700	Left Head Cheek	0.555	0.372	0.927
	Left Head Tilt	0.343	0.372	0.715
	Right Head Cheek	0.574	0.372	0.946
	Right Head Tilt	0.351	0.372	0.723
WCDMA 1900	Left Head Cheek	0.592	0.372	0.964
	Left Head Tilt	0.306	0.372	0.678
	Right Head Cheek	0.585	0.372	0.957
	Right Head Tilt	0.298	0.372	0.670

LTE with Wi-Fi:

Mode	Position	Reported SAR (W/kg)		ΣSAR
		LTE	Wi-Fi	< 1.6W/kg
LTE Band 2	Left Head Cheek	0.622	0.372	0.994
	Left Head Tilt	0.319	0.372	0.691
	Right Head Cheek	0.629	0.372	1.001
	Right Head Tilt	0.311	0.372	0.683
LTE Band 4	Left Head Cheek	0.345	0.372	0.717
	Left Head Tilt	0.169	0.372	0.541
	Right Head Cheek	0.341	0.372	0.713
	Right Head Tilt	0.158	0.372	0.530

Conclusion:

ΣSAR < 1.6 W/kg therefore simultaneous transmission SAR with Volume Scans is **not** required.

Evaluations for Simultaneous SAR, BT+GSM/3G/4G					
Test Position	Body-Back (1.0cm)	Body-Left (1.0cm)	Body-Right (1.0cm)	Body-Bottom (1.0cm)	Body-Top (1.0cm)
Mode	Stand Alone 1-g SAR (W/Kg)				
GPRS 850	1.044	0.572	0.693	0.382	/
GPRS 1900	0.880	0.289	0.324	0.530	/
WCDMA 850	0.315	0.161	0.177	0.126	/
WCDMA 1700	1.120	0.432	0.469	0.822	/
WCDMA 1900	1.295	0.368	0.411	0.771	/
LTE Band 2	1.358	0.395	0.433	0.804	/
LTE Band 4	0.644	0.268	0.303	0.566	/
BT	0.108	0.108	0.108	0.108	0.108
	Σ 1-g SAR(W/Kg)				
GPRS 850 + BT	1.152	0.680	0.801	0.490	/
GPRS 1900 + BT	0.988	0.397	0.432	0.638	/
WCDMA 850 + BT	0.423	0.269	0.285	0.234	/
WCDMA 1700 + BT	1.228	0.540	0.577	0.930	/
WCDMA 1900+ BT	1.403	0.476	0.519	0.879	/
LTE Band 2+ BT	1.466	0.503	0.541	0.912	/
LTE Band 4+ BT	0.752	0.376	0.411	0.674	/

Evaluations for Simultaneous SAR, Mobile Hot Spot Positions					
Test Position	Body-Back (1.0cm)	Body-Left (1.0cm)	Body-Right (1.0cm)	Body-Bottom (1.0cm)	Body-Top (1.0cm)
Mode	Stand Alone 1-g SAR (W/Kg)				
GPRS 850	1.044	0.572	0.693	0.382	/
GPRS 1900	0.880	0.289	0.324	0.530	/
WCDMA 850	0.315	0.161	0.177	0.126	/
WCDMA 1700	1.120	0.432	0.469	0.822	/
WCDMA 1900	1.295	0.368	0.411	0.771	/
LTE Band 2	1.358	0.395	0.433	0.804	/
LTE Band 4	0.644	0.268	0.303	0.566	/
Wi-Fi	0.186	0.186	0.186	0.186	0.186
	Σ 1-g SAR(W/Kg)				
GPRS 850 + Wi-Fi	1.230	0.758	0.879	0.568	/
GPRS 1900 + Wi-Fi	1.066	0.475	0.510	0.716	/
WCDMA 850 + Wi-Fi	0.501	0.347	0.363	0.312	/
WCDMA 1700+ Wi-Fi	1.306	0.618	0.655	1.008	/
WCDMA 1900+ Wi-Fi	1.481	0.554	0.597	0.957	/
LTE Band 2+ Wi-Fi	1.544	0.581	0.619	0.990	/
LTE Band 4+ Wi-Fi	0.830	0.454	0.489	0.752	/

Note:

If the sum of the 1g SAR measured for the simultaneously transmitting antennas is less than the SAR limit, SAR measurement for simultaneous transmission is not required.

SAR Plots (Summary of the Highest SAR Values)

Test Laboratory: Bay Area Compliance Lab Corp. (Shenzhen)

Left Head Cheek (824.2 MHz Low Channel)

Measurement Data

Test mode : GSM
 Crest Factor : 8
 Scan Type : Complete
 Area Scan : 11x8x1: Measurement x=10mm, y=10mm, z=4mm
 Zoom Scan : 7x7x7: Measurement x=5mm, y=5mm, z=5mm
 Power Drift-Start : 0.028 W/kg
 Power Drift-Finish : 0.028 W/kg
 Power Drift (%) : -2.716

Tissue Data

Type : Head
 Frequency : 824.2 MHz
 Epsilon : 41.03 F/m
 Sigma : 0.90 S/m
 Density : 1000.00 kg/cu. m

Probe Data

Serial No. : 500-00283
 Frequency Band : 835
 Duty Cycle Factor : 8
 Conversion Factor : 5.9
 Probe Sensitivity : 1.20 1.20 1.20 $\mu\text{V}/(\text{V}/\text{m})^2$
 Compression Point : 95.00 mV
 Offset : 1.56 mm

1 gram SAR value : 0.523 W/kg
 10 gram SAR value : 0.256 W/kg
 Area Scan Peak SAR : 0.535 W/kg
 Zoom Scan Peak SAR : 0.802 W/kg

Plot 1#

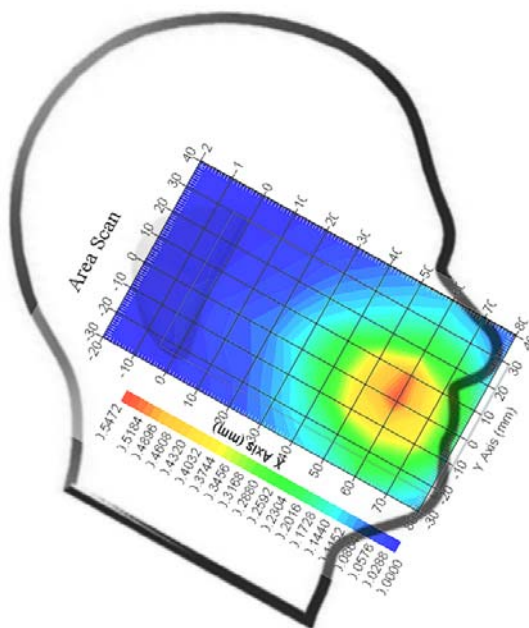

Test Laboratory: Bay Area Compliance Lab Corp. (Shenzhen)

Left Head Cheek(1850.2 MHz Low Channel)

Measurement Data

Test mode : GSM
 Crest Factor : 8
 Scan Type : Complete
 Area Scan : 11x8x1 : Measurement x=10mm, y=10mm, z=4mm
 Zoom Scan : 7x7x7 : Measurement x=5mm, y=5mm, z=5mm
 Power Drift-Start : 0.018 W/kg
 Power Drift-Finish : 0.018 W/kg
 Power Drift (%) : -0.582

Tissue Data

Type : Head
 Frequency : 1850.2 MHz
 Epsilon : 39.73 F/m
 Sigma : 1.38 S/m
 Density : 1000.00 kg/cu. M

Probe Data

Serial No. : 500-00283
 Frequency Band : 1900
 Duty Cycle Factor : 8
 Conversion Factor : 4.8
 Probe Sensitivity : 1.20 1.20 1.20 $\mu\text{V}/(\text{V}/\text{m})^2$
 Compression Point : 95.00 mV
 Offset : 1.56 mm

1 gram SAR value : 0.412 W/kg
 10 gram SAR value : 0.206 W/kg
 Area Scan Peak SAR : 0.420 W/kg
 Zoom Scan Peak SAR : 0.644 W/kg

Plot 2#

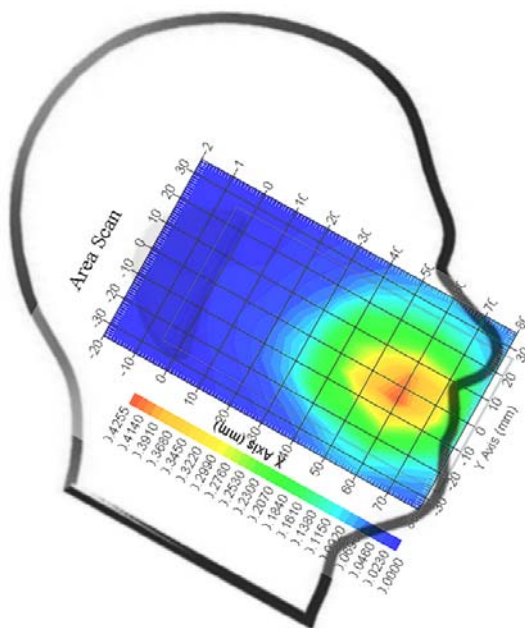

Test Laboratory: Bay Area Compliance Lab Corp. (Shenzhen)

WCDMA850; Left Head Cheek (826.4 MHz Low Channel)

Measurement Data

Test mode : RMC
 Crest Factor : 1
 Scan Type : Complete
 Area Scan : 11x8x1: Measurement x=10mm, y=10mm, z=4mm
 Zoom Scan : 7x7x7: Measurement x=5mm, y=5mm, z=5mm
 Power Drift-Start : 0.009 W/kg
 Power Drift-Finish : 0.009 W/kg
 Power Drift (%) : 0.687

Tissue Data

Type : Head
 Frequency : 826.4 MHz
 Epsilon : 41.03 F/m
 Sigma : 0.90 S/m
 Density : 1000.00 kg/cu. m

Probe Data

Serial No. : 500-00283
 Frequency Band : 835
 Duty Cycle Factor : 1
 Conversion Factor : 5.9
 Probe Sensitivity : 1.20 1.20 1.20 $\mu\text{V}/(\text{V/m})^2$
 Compression Point : 95.00 mV
 Offset : 1.56 mm

1 gram SAR value : 0.164 W/kg
 10 gram SAR value : 0.090 W/kg
 Area Scan Peak SAR : 0.170 W/kg
 Zoom Scan Peak SAR : 0.271 W/kg

Plot 3#

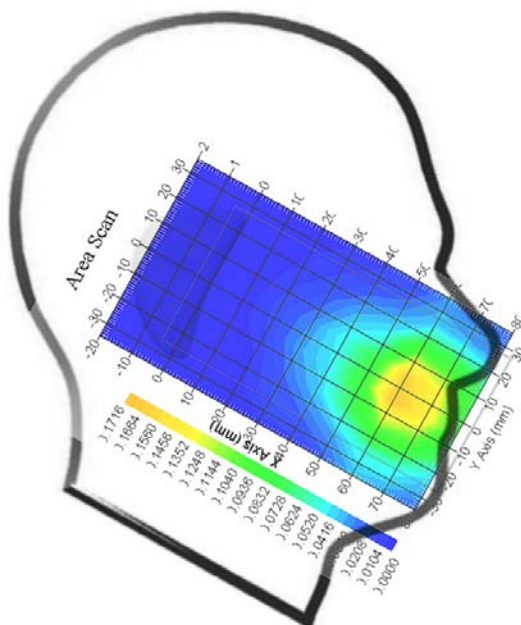

Test Laboratory: Bay Area Compliance Lab Corp. (Shenzhen)

WCDMA 1700; Right Head Cheek (1732.6 MHz Middle Channel)

Measurement Data

Test mode : RMC
 Crest Factor : 1
 Scan Type : Complete
 Area Scan : 11x8x1: Measurement x=10mm, y=10mm, z=4mm
 Zoom Scan : 7x7x7: Measurement x=5mm, y=5mm, z=5mm
 Power Drift-Start : 0.012 W/kg
 Power Drift-Finish : 0.012 W/kg
 Power Drift (%) : -1.711

Tissue Data

Type : Head
 Frequency : 1732.6 MHz
 Epsilon : 39.40 F/m
 Sigma : 1.38 S/m
 Density : 1000.00 kg/cu. m

Probe Data

Serial No. : 500-00283
 Frequency Band : 1750
 Duty Cycle Factor : 1
 Conversion Factor : 5.4
 Probe Sensitivity : 1.20 1.20 1.20 $\mu\text{V}/(\text{V}/\text{m})^2$
 Compression Point : 95.00 mV
 Offset : 1.56 mm

1 gram SAR value : 0.544 W/kg
 10 gram SAR value : 0.317 W/kg
 Area Scan Peak SAR : 0.590 W/kg
 Zoom Scan Peak SAR : 0.866 W/kg

Plot 4#

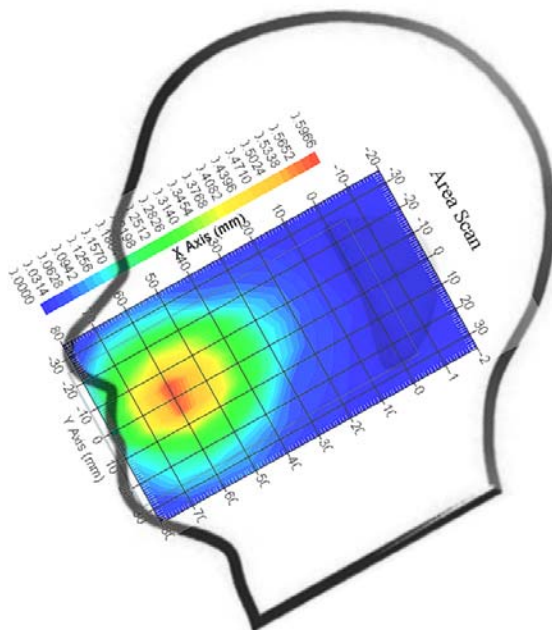

Test Laboratory: Bay Area Compliance Lab Corp. (Shenzhen)

WCDMA 1900; Left Head Cheek (1907.6 MHz High Channel)

Measurement Data

Test mode : RMC
 Crest Factor : 1
 Scan Type : Complete
 Area Scan : 11x9x1: Measurement x=10mm, y=10mm, z=4mm
 Zoom Scan : 7x7x7: Measurement x=5mm, y=5mm, z=5mm
 Power Drift-Start : 0.034 W/kg
 Power Drift-Finish : 0.034 W/kg
 Power Drift (%) : 3.115

Tissue Data

Type : Head
 Frequency : 1907.6 MHz
 Epsilon : 39.72 F/m
 Sigma : 1.41 S/m
 Density : 1000.00 kg/cu. m

Probe Data

Serial No. : 500-00283
 Frequency Band : 1900
 Duty Cycle Factor : 1
 Conversion Factor : 4.8
 Probe Sensitivity : 1.20 1.20 1.20 $\mu\text{V}/(\text{V/m})^2$
 Compression Point : 95.00 mV
 Offset : 1.56 mm

1 gram SAR value : 0.587 W/kg
 10 gram SAR value : 0.304 W/kg
 Area Scan Peak SAR : 0.603 W/kg
 Zoom Scan Peak SAR : 0.911 W/kg

Plot 5#

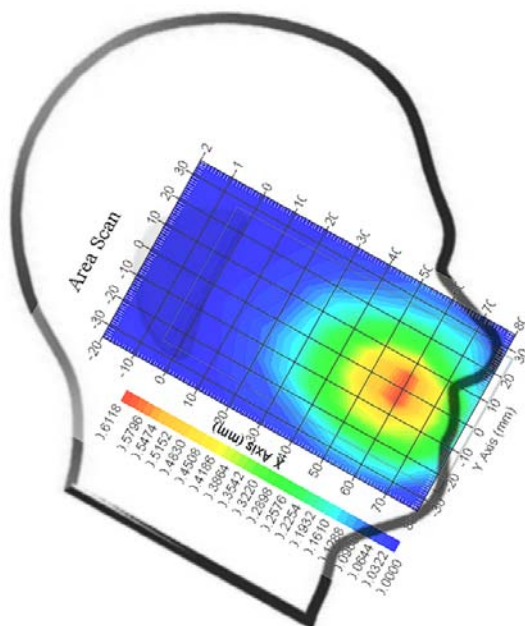

Test Laboratory: Bay Area Compliance Lab Corp. (Shenzhen)

LTE FDD Band2; Right-Head-Cheek (1900 MHz High Channel);

Measurement Data

Test mode : RB1
 Crest Factor : 1
 Scan Type : Complete
 Area Scan : 8x11x1 : Measurement x=10mm, y=10mm, z=4mm
 Zoom Scan : 7x7x7 : Measurement x=5mm, y=5mm, z=5mm
 Power Drift-Start : 0.028 W/kg
 Power Drift-Finish : 0.028 W/kg
 Power Drift (%) : 0.973

Tissue Data

Type : Head
 Frequency : 1900 MHz
 Epsilon : 39.70 F/m
 Sigma : 1.42 S/m
 Density : 1000.00 kg/cu. m

Probe Data

Serial No. : 500-00283
 Frequency Band : 1900
 Duty Cycle Factor : 1
 Conversion Factor : 4.8
 Probe Sensitivity : 1.20 1.20 1.20 $\mu\text{V}/(\text{V}/\text{m})^2$
 Compression Point : 95.00 mV
 Offset : 1.56 mm

1 gram SAR value : 0.619 W/kg
 10 gram SAR value : 0.308 W/kg
 Area Scan Peak SAR : 0.630 W/kg
 Zoom Scan Peak SAR : 0.952 W/kg

Plot 6#

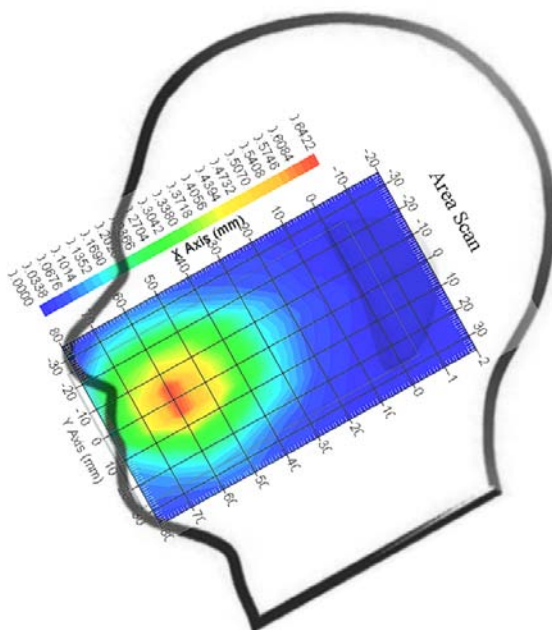

Test Laboratory: Bay Area Compliance Lab Corp. (Shenzhen)

LTE FDD Band4; Left-Head-Cheek (1732.5 MHz Middle Channel);

Measurement Data

Test mode : RB1
 Crest Factor : 1
 Scan Type : Complete
 Area Scan : 8x11x1 : Measurement x=10mm, y=10mm, z=4mm
 Zoom Scan : 7x7x7 : Measurement x=5mm, y=5mm, z=5mm
 Power Drift-Start : 0.018 W/kg
 Power Drift-Finish : 0.018 W/kg
 Power Drift (%) : -1.461

Tissue Data

Type : Head
 Frequency : 1732.5 MHz
 Epsilon : 39.40 F/m
 Sigma : 1.38 S/m
 Density : 1000.00 kg/cu. m

Probe Data

Serial No. : 500-00283
 Frequency Band : 1750
 Duty Cycle Factor : 1
 Conversion Factor : 5.4
 Probe Sensitivity : 1.20 1.20 1.20 $\mu\text{V}/(\text{V}/\text{m})^2$
 Compression Point : 95.00 mV
 Offset : 1.56 mm

1 gram SAR value : 0.343 W/kg
 10 gram SAR value : 0.165 W/kg
 Area Scan Peak SAR : 0.350 W/kg
 Zoom Scan Peak SAR : 0.538 W/kg

Plot 7#

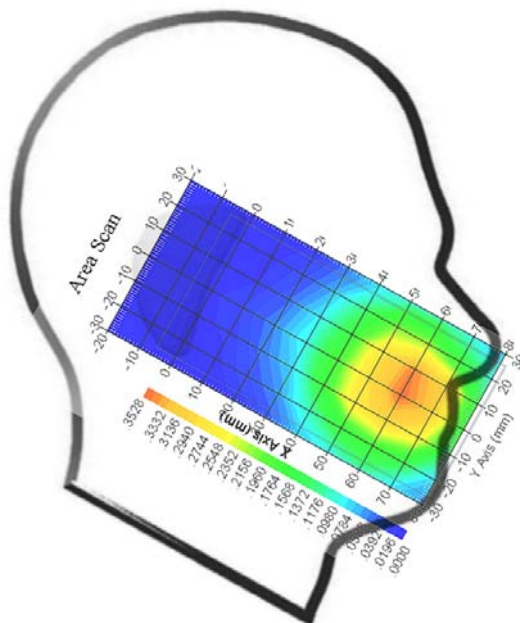

Test Laboratory: Bay Area Compliance Lab Corp. (Shenzhen)

Body-worn-Back (836.6 MHz Middle Channel)

Measurement Data

Test mode : GPRS
 Crest Factor : 2
 Scan Type : Complete
 Area Scan : 8x11x1 : Measurement x=10mm, y=10mm, z=4mm
 Zoom Scan : 7x7x7 : Measurement x=5mm, y=5mm, z=5mm
 Power Drift-Start : 0.429 W/kg
 Power Drift-Finish : 0.425 W/kg
 Power Drift (%) : -0.572

Tissue Data

Type : Body
 Frequency : 836.6 MHz
 Epsilon : 53.77 F/m
 Sigma : 0.96 S/m
 Density : 1000.00 kg/cu. m

Probe Data

Serial No. : 500-00283
 Frequency Band : 835
 Duty Cycle Factor : 2
 Conversion Factor : 5.9
 Probe Sensitivity : 1.20 1.20 1.20 $\mu\text{V}/(\text{V}/\text{m})^2$
 Compression Point : 95.00 mV
 Offset : 1.56 mm

1 gram SAR value : 1.027 W/kg
 10 gram SAR value : 0.704 W/kg
 Area Scan Peak SAR : 1.046 W/kg
 Zoom Scan Peak SAR : 1.579 W/kg

Plot 8#

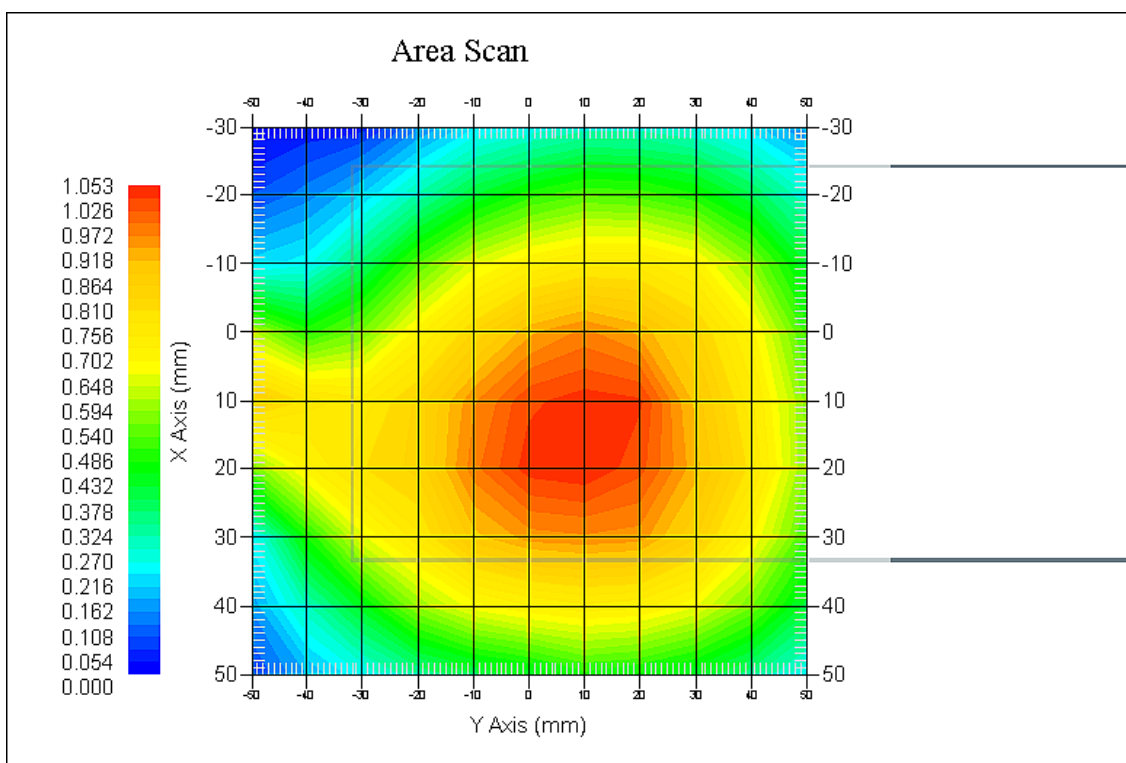

Test Laboratory: Bay Area Compliance Lab Corp. (Shenzhen)

Body-worn-Back (1909.8 MHz High Channel)

Measurement Data

Test mode : GPRS
 Crest Factor : 2
 Scan Type : Complete
 Area Scan : 8x11x1 : Measurement x=10mm, y=10mm, z=4mm
 Zoom Scan : 7x7x7 : Measurement x=5mm, y=5mm, z=5mm
 Power Drift-Start : 0.213 W/kg
 Power Drift-Finish : 0.216 W/kg
 Power Drift (%) : 1.408

Tissue Data

Type : Body
 Frequency : 1909.8 MHz
 Epsilon : 52.09 F/m
 Sigma : 1.54 S/m
 Density : 1000.00 kg/cu. m

Probe Data

Serial No. : 500-00283
 Frequency Band : 1900
 Duty Cycle Factor : 2
 Conversion Factor : 4.5
 Probe Sensitivity : 1.20 1.20 1.20 $\mu\text{V}/(\text{V}/\text{m})^2$
 Compression Point : 95.00 mV
 Offset : 1.56 mm

1 gram SAR value : 0.864 W/kg
 10 gram SAR value : 0.425 W/kg
 Area Scan Peak SAR : 0.893 W/kg
 Zoom Scan Peak SAR : 1.356 W/kg

Plot 9#

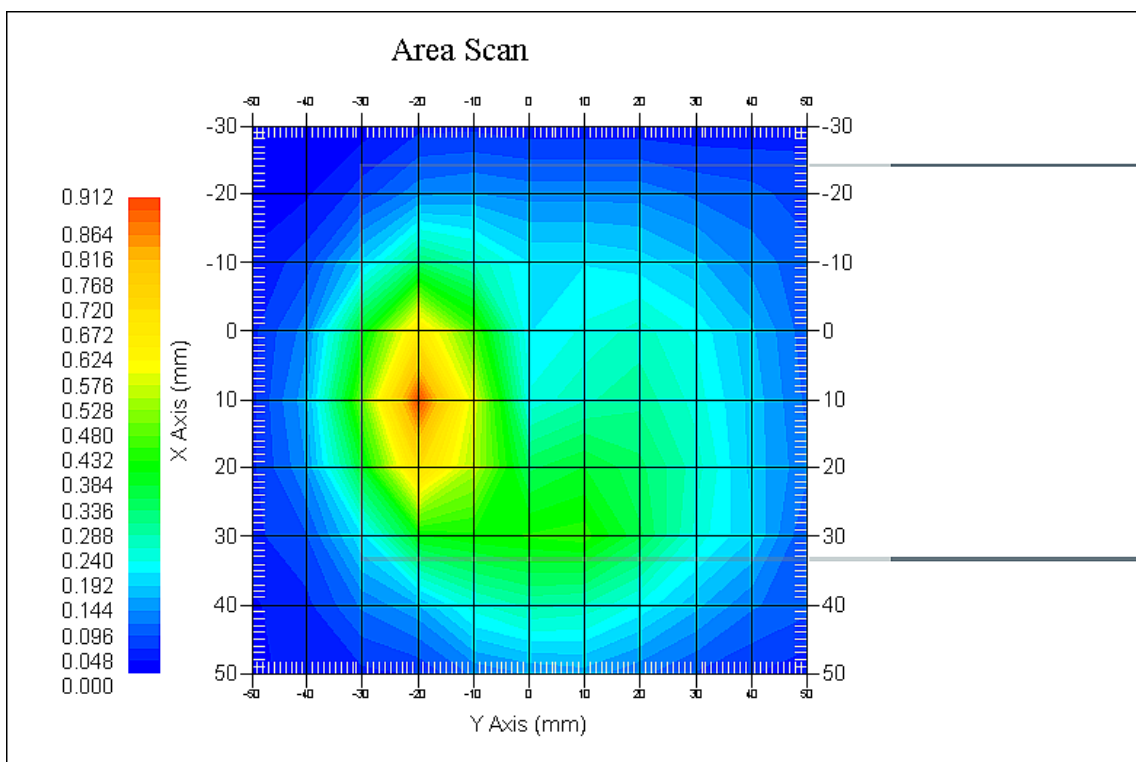

Test Laboratory: Bay Area Compliance Lab Corp. (Shenzhen)

WCDMA850; Body-Worn-Back (826.4 MHz Low Channel)

Measurement Data

Test mode : RMC
 Crest Factor : 1
 Scan Type : Complete
 Area Scan : 11x8x1: Measurement x=10mm, y=10mm, z=4mm
 Zoom Scan : 7x7x7: Measurement x=5mm, y=5mm, z=5mm
 Power Drift-Start : 0.246 W/kg
 Power Drift-Finish : 0.249 W/kg
 Power Drift (%) : 1.220

Tissue Data

Type : Body
 Frequency : 826.4 MHz
 Epsilon : 53.83 F/m
 Sigma : 0.95 S/m
 Density : 1000.00 kg/cu. m

Probe Data

Serial No. : 500-00283
 Frequency Band : 835
 Duty Cycle Factor : 1
 Conversion Factor : 5.9
 Probe Sensitivity : 1.20 1.20 1.20 $\mu\text{V}/(\text{V/m})^2$
 Compression Point : 95.00 mV
 Offset : 1.56 mm

1 gram SAR value : 0.309 W/kg
 10 gram SAR value : 0.162 W/kg
 Area Scan Peak SAR : 0.318 W/kg
 Zoom Scan Peak SAR : 0.485 W/kg

Plot 10#

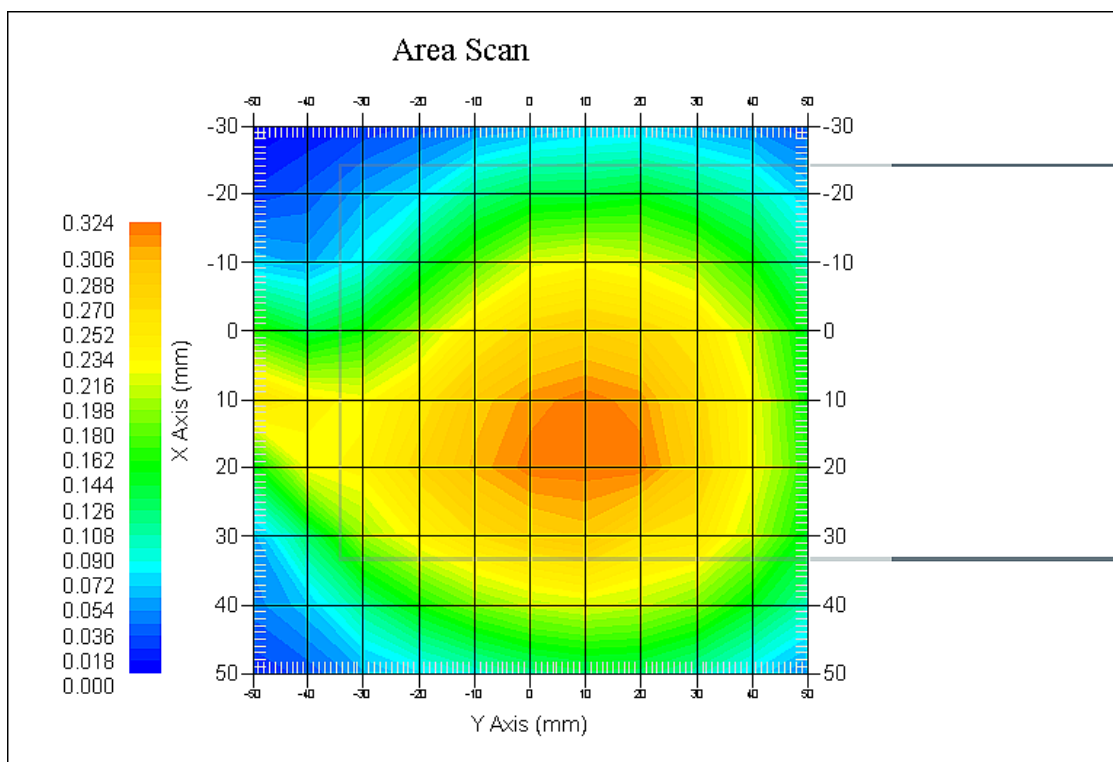

Test Laboratory: Bay Area Compliance Lab Corp. (Shenzhen)

WCDMA1700; Body-Worn-Back (1752.6 MHz High Channel)

Measurement Data

Test mode : RMC
 Crest Factor : 1
 Scan Type : Complete
 Area Scan : 11x9x1: Measurement x=10mm, y=10mm, z=4mm
 Zoom Scan : 7x7x7: Measurement x=5mm, y=5mm, z=5mm
 Power Drift-Start : 0.783 W/kg
 Power Drift-Finish : 0.771 W/kg
 Power Drift (%) : -1.644

Tissue Data

Type : Body
 Frequency : 1752.6 MHz
 Epsilon : 51.91 F/m
 Sigma : 1.53 S/m
 Density : 1000.00 kg/cu. m

Probe Data

Serial No. : 500-00283
 Frequency Band : 1900
 Duty Cycle Factor : 1
 Conversion Factor : 5.3
 Probe Sensitivity : 1.20 1.20 1.20 $\mu\text{V}/(\text{V}/\text{m})^2$
 Compression Point : 95.00 mV
 Offset : 1.56 mm

1 gram SAR value : 1.105 W/kg
 10 gram SAR value : 0.576 W/kg
 Area Scan Peak SAR : 1.181 W/kg
 Zoom Scan Peak SAR : 1.917 W/kg

Plot 11#

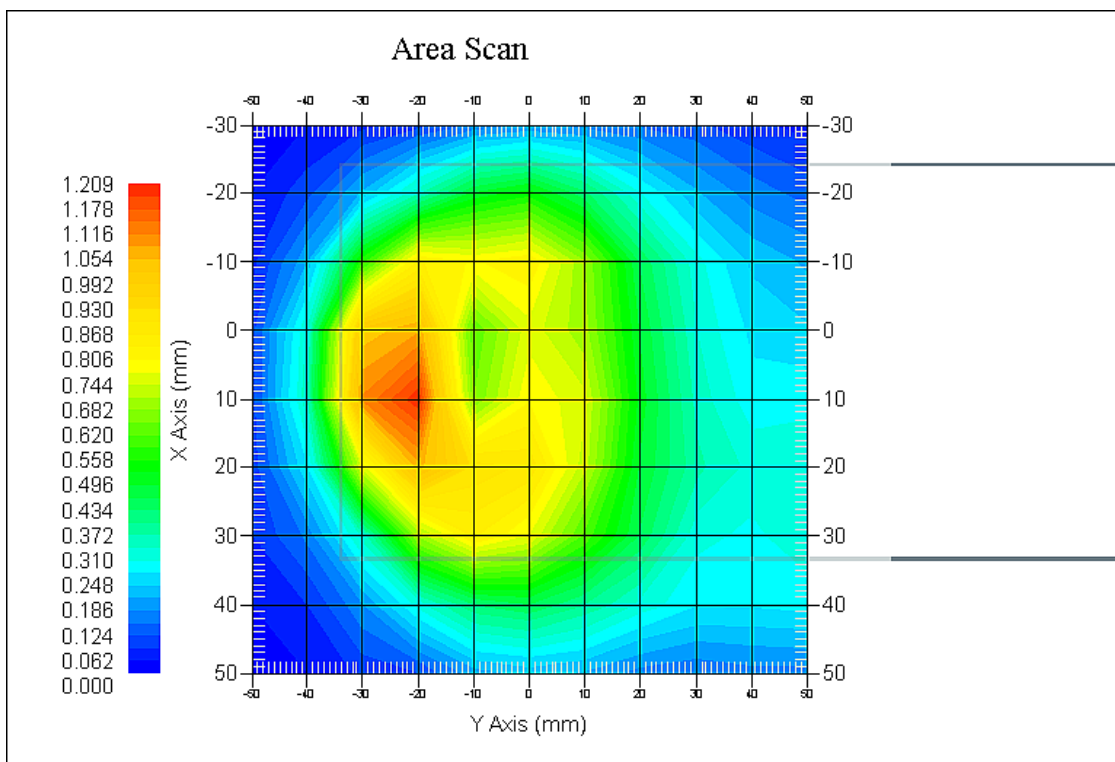

Test Laboratory: Bay Area Compliance Lab Corp. (Shenzhen)

WCDMA1900; Body-Worn-Back (1907.6 MHz High Channel)

Measurement Data

Test mode : RMC
 Crest Factor : 1
 Scan Type : Complete
 Area Scan : 11x9x1: Measurement x=10mm, y=10mm, z=4mm
 Zoom Scan : 7x7x7: Measurement x=5mm, y=5mm, z=5mm
 Power Drift-Start : 0.335 W/kg
 Power Drift-Finish : 0.331 W/kg
 Power Drift (%) : -1.194

Tissue Data

Type : Body
 Frequency : 1907.6 MHz
 Epsilon : 52.08 F/m
 Sigma : 1.53 S/m
 Density : 1000.00 kg/cu. m

Probe Data

Serial No. : 500-00283
 Frequency Band : 1900
 Duty Cycle Factor : 1
 Conversion Factor : 4.8
 Probe Sensitivity : 1.20 1.20 1.20 $\mu\text{V}/(\text{V/m})^2$
 Compression Point : 95.00 mV
 Offset : 1.56 mm

1 gram SAR value : 1.283 W/kg
 10 gram SAR value : 0.652 W/kg
 Area Scan Peak SAR : 1.304 W/kg
 Zoom Scan Peak SAR : 2.267 W/kg

Plot 12#

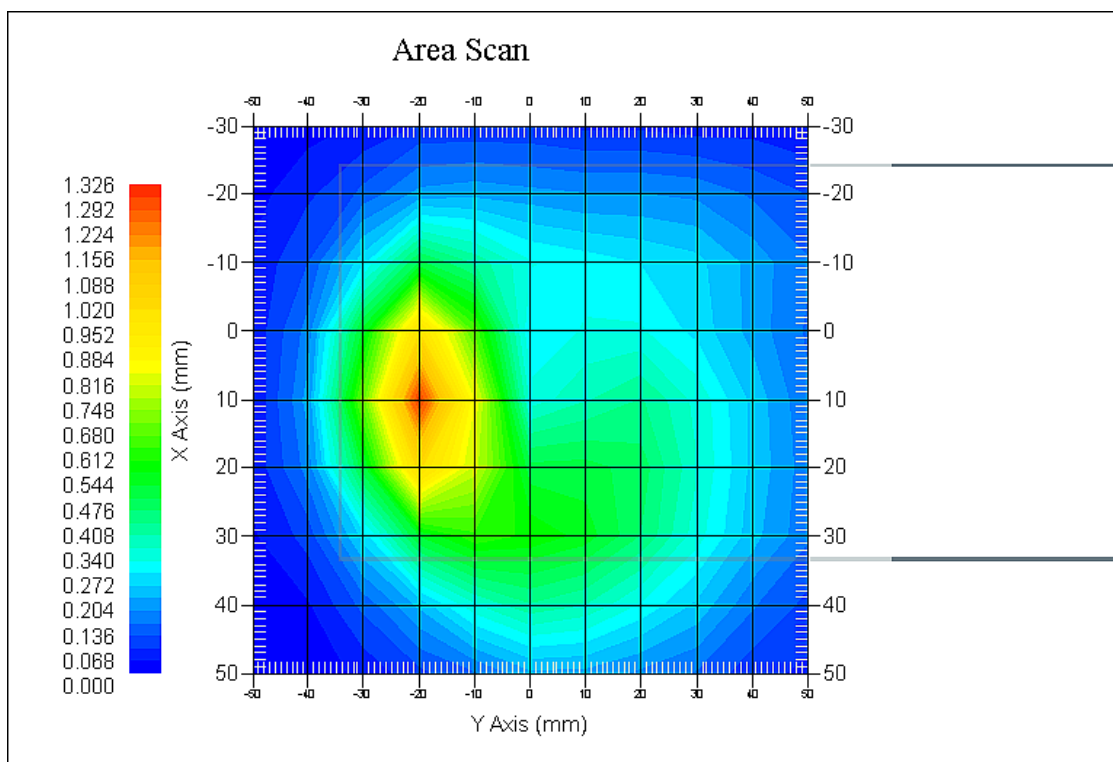

Test Laboratory: Bay Area Compliance Lab Corp. (Shenzhen)

LTE FDD Band2; Body-Worn-Back (1900 MHz High Channel);

Measurement Data

Test mode : 1RB
 Crest Factor : 1
 Scan Type : Complete
 Area Scan : 8x11x1 : Measurement x=10mm, y=10mm, z=4mm
 Zoom Scan : 7x7x7 : Measurement x=5mm, y=5mm, z=5mm
 Power Drift-Start : 0.606 W/kg
 Power Drift-Finish : 0.591 W/kg
 Power Drift (%) : -2.475

Tissue Data

Type : Body
 Frequency : 1900 MHz
 Epsilon : 52.05 F/m
 Sigma : 1.52 S/m
 Density : 1000.00 kg/cu. m

Probe Data

Serial No. : 500-00283
 Frequency Band : 1900
 Duty Cycle Factor : 1
 Conversion Factor : 4.5
 Probe Sensitivity : 1.20 1.20 1.20 $\mu\text{V}/(\text{V}/\text{m})^2$
 Compression Point : 95.00 mV
 Offset : 1.56 mm

1 gram SAR value : 1.336 W/kg
 10 gram SAR value : 0.690 W/kg
 Area Scan Peak SAR : 1.374 W/kg
 Zoom Scan Peak SAR : 2.102 W/kg

Plot 13#

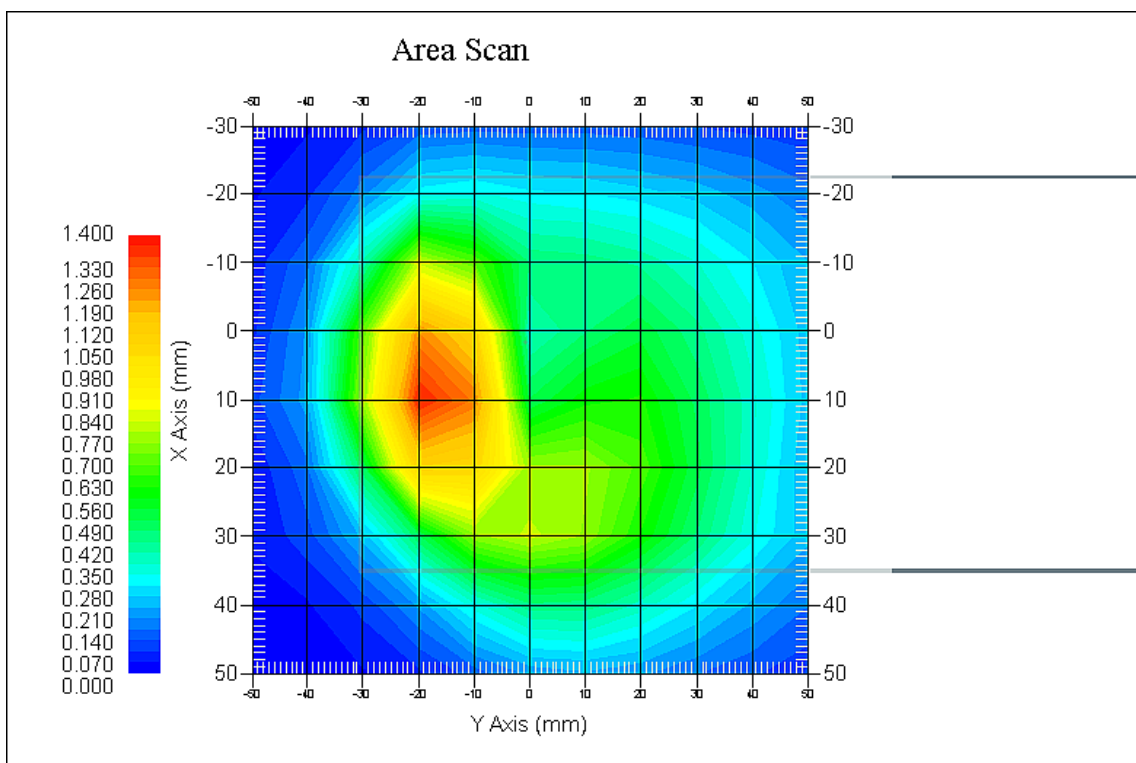

Test Laboratory: Bay Area Compliance Lab Corp. (Shenzhen)

LTE FDD Band4; Body-Worn-Back (1732.5 MHz Middle Channel);

Measurement Data

Test mode : 1RB
 Crest Factor : 1
 Scan Type : Complete
 Area Scan : 8x11x1 : Measurement x=10mm, y=10mm, z=4mm
 Zoom Scan : 7x7x7 : Measurement x=5mm, y=5mm, z=5mm
 Power Drift-Start : 0.211 W/kg
 Power Drift-Finish : 0.204 W/kg
 Power Drift (%) : -3.318

Tissue Data

Type : Body
 Frequency : 1732.5 MHz
 Epsilon : 51.95 F/m
 Sigma : 1.50 S/m
 Density : 1000.00 kg/cu. m

Probe Data

Serial No. : 500-00283
 Frequency Band : 1750
 Duty Cycle Factor : 1
 Conversion Factor : 5.3
 Probe Sensitivity : 1.20 1.20 1.20 $\mu\text{V}/(\text{V}/\text{m})^2$
 Compression Point : 95.00 mV
 Offset : 1.56 mm

1 gram SAR value : 0.641 W/kg
 10 gram SAR value : 0.327 W/kg
 Area Scan Peak SAR : 0.673 W/kg
 Zoom Scan Peak SAR : 0.985 W/kg

Plot 14#

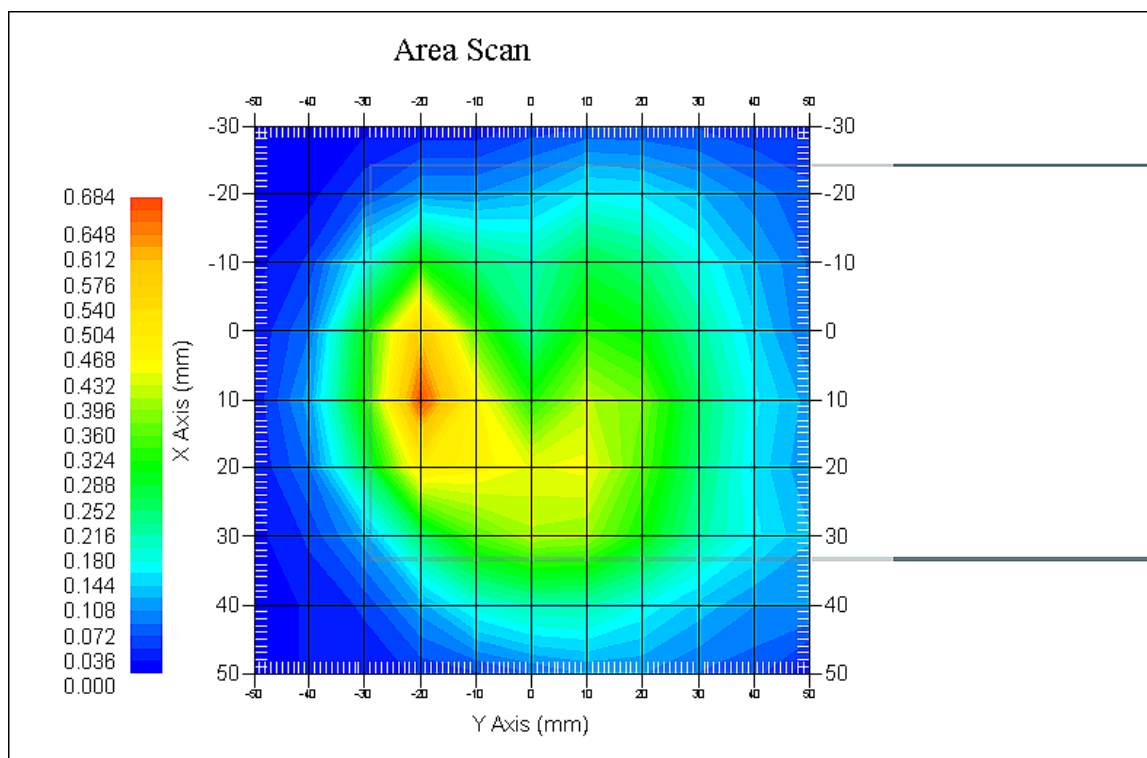

APPENDIX A MEASUREMENT UNCERTAINTY

According to **IEEE1528:2013**, the uncertainty budget has been determined for the Head SAR measurement system and is given in the following Table.

Source of Uncertainty	Tolerance Value	Probability Distribution	Divisor	c_i^1 (1-g)	c_i^1 (10-g)	Standard Uncertainty (1-g) %	Standard Uncertainty (10-g) %
Measurement System							
Probe Calibration	3.5	normal	1	1	1	3.5	3.5
Axial Isotropy	3.7	rectangular	$\sqrt{3}$	$(1-cp)^{1/2}$	$(1-cp)^{1/2}$	1.5	1.5
Hemispherical Isotropy	10.9	rectangular	$\sqrt{3}$	\sqrt{cp}	\sqrt{cp}	4.4	4.4
Boundary Effect	1.0	rectangular	$\sqrt{3}$	1	1	0.6	0.6
Linearity	4.7	rectangular	$\sqrt{3}$	1	1	2.7	2.7
Detection Limit	1.0	rectangular	$\sqrt{3}$	1	1	0.6	0.6
Readout Electronics	1.0	normal	1	1	1	1.0	1.0
Response Time	0.8	rectangular	$\sqrt{3}$	1	1	0.5	0.5
Integration Time	1.7	rectangular	$\sqrt{3}$	1	1	1.0	1.0
RF Ambient Condition -Noise	0.6	rectangular	$\sqrt{3}$	1	1	0.3	0.3
RF Ambient Condition - Reflections	3.0	rectangular	$\sqrt{3}$	1	1	1.7	1.7
Probe Positioner Mech. Restrictions	0.4	rectangular	$\sqrt{3}$	1	1	0.2	0.2
Probe Positioning with respect to Phantom Shell	2.9	rectangular	$\sqrt{3}$	1	1	1.7	1.7
Extrapolation and Integration	3.7	rectangular	$\sqrt{3}$	1	1	2.1	2.1
Test sample related							
Test sample positioning	2.0	normal	1	1	1	2.0	2.0
Device Holder Uncertainty	4.0	normal	1	1	1	6.215	6.215
Drift of Output Power	5.0	rectangular	$\sqrt{3}$	1	1	2.67	2.67
Phantom and Setup							
Phantom Uncertainty	3.4	rectangular	$\sqrt{3}$	1	1	2.0	2.0
SAR correction in permittivity and conductivity	1.2	normal	1	1	0.85	1.2	1.0
Liquid conductivity measurement	5.0	normal	1	0.78	0.71	3.9	3.6
Liquid permittivity measurement	5.0	normal	1	0.25	0.29	1.3	1.5
conductivity—temperature	1.1	rectangular	$\sqrt{3}$	0.78	0.71	0.5	0.5
permittivity—temperature	1.3	rectangular	$\sqrt{3}$	0.23	0.23	0.2	0.2
Combined Uncertainty		RSS				10.78	10.55
Expanded uncertainty (coverage factor=2)		Normal(k=2)				21.56	21.10

According to **IEC62209-2:2010**, the uncertainty budget has been determined for the Body SAR measurement system and is given in the following Table.

Source of Uncertainty	Tolerance Value	Probability Distribution	Divisor	c_i^1 (1-g)	c_i^1 (10-g)	Standard Uncertainty (1-g) %	Standard Uncertainty (10-g) %
Measurement System							
Probe Calibration	3.5	normal	1	1	1	3.5	3.5
Axial Isotropy	3.7	rectangular	$\sqrt{3}$	1	1	1.5	1.5
Boundary Effect	1.0	rectangular	$\sqrt{3}$	1	1	0.6	0.6
Linearity	4.7	rectangular	$\sqrt{3}$	1	1	2.7	2.7
Detection Limit	1.0	rectangular	$\sqrt{3}$	1	1	0.6	0.6
Readout Electronics	1.0	normal	1	1	1	1.0	1.0
Response Time	0.8	rectangular	$\sqrt{3}$	1	1	0.5	0.5
Integration Time	1.7	rectangular	$\sqrt{3}$	1	1	1.0	1.0
RF Ambient Condition -Noise	0.6	rectangular	$\sqrt{3}$	1	1	0.3	0.3
RF Ambient Condition - Reflections	3.0	rectangular	$\sqrt{3}$	1	1	1.7	1.7
Probe Positioner Mech. Restrictions	0.4	rectangular	$\sqrt{3}$	1	1	0.2	0.2
Probe Positioning with respect to Phantom Shell	2.9	rectangular	$\sqrt{3}$	1	1	1.7	1.7
Extrapolation and Integration	3.7	rectangular	$\sqrt{3}$	1	1	2.1	2.1
Test sample related							
Test sample positioning	2.0	normal	1	1	1	2.0	2.0
Device Holder Uncertainty	4.0	normal	1	1	1	6.215	6.215
Drift of Output Power	5.0	rectangular	$\sqrt{3}$	1	1	2.67	2.67
Phantom and Setup							
Phantom Uncertainty	3.4	rectangular	$\sqrt{3}$	1	1	2.0	2.0
SAR correction in permittivity and conductivity	1.2	normal	1	1	0.84	1.2	1.0
Liquid conductivity measurement	5.0	normal	1	0.78	0.71	3.9	3.6
Liquid permittivity measurement	5.0	normal	1	0.23	0.26	1.3	1.5
conductivity—temperature	1.1	rectangular	$\sqrt{3}$	0.78	0.71	0.5	0.5
permittivity—temperature	1.3	rectangular	$\sqrt{3}$	0.23	0.26	0.2	0.2
Combined Uncertainty		RSS				9.58	9.49
Expanded uncertainty (coverage factor=2)		Normal(k=2)				19.16	18.98

APPENDIX B – PROBE CALIBRATION CERTIFICATES

NCL CALIBRATION LABORATORIES

Calibration File No.: PC-1598

Task No: BACL-5778

CERTIFICATE OF CALIBRATION

It is certified that the equipment identified below has been calibrated in the
NCL CALIBRATION LABORATORIES by qualified personnel following recognized
procedures and using transfer standards traceable to NRC/NIST.

Equipment: Miniature Isotropic RF Probe

Record of Calibration

Head and Body

Manufacturer: APREL Laboratories

Model No.: E-020

Serial No.: 500-00283

Calibration Procedure: D01-032-E020-V2, D22-012-Tissue, D28-002-Dipole
Project No: BACL-5745

Calibrated: 14th October 2014
Released on: 14th October 2014

This Calibration Certificate is Incomplete Unless Accompanied with the Calibration Results Summary

Released By: _____



Art Brennan, Quality Manager

NCL CALIBRATION LABORATORIES

Suite 102, 303 Terry Fox Dr,
OTTAWA, ONTARIO
CANADA K2K 3J1

Division of APREL Lab.
TEL: (613) 435-8300
FAX: (613) 435-8306

NCL Calibration Laboratories

Division of APREL Inc.

Introduction

This Calibration Report reproduces the results of the calibration performed in line with the references listed below. Calibration is performed using accepted methodologies as per the references listed below. Probes are calibrated for air, and tissue and the values reported are the results from the physical quantification of the probe through metrological practices.

Calibration Method

Probes are calibrated using the following methods.

<1000MHz

TEM Cell for sensitivity in air

Standard phantom using temperature transfer method for sensitivity in tissue

>1000MHz

Waveguide* method to determine sensitivity in air and tissue

*Waveguide is numerically (simulation) assessed to determine the field distribution and power

The boundary effect for the probe is assessed using a standard flat phantom where the probe output is compared against a numerically simulated series of data points

References

- IEEE Standard 1528
IEEE Recommended Practice for Determining the Peak Spatial-Average Specific Absorption Rate (SAR) in the Human Head from Wireless Communications Devices: Measurement Techniques
- EN 62209-1
Human Exposure to RF Fields from hand-held and body-mounted wireless communication devices - Human models, instrumentation, and procedures-Part 1: Procedure to measure the Specific Absorption Rate (SAR) for hand-held mobile wireless devices
- IEC 62209-2
Human exposure to RF fields from hand-held and body-mounted wireless devices - Human models, instrumentation, and procedures - Part 2: specific absorption rate (SAR) for wireless communication devices (30 MHz - 6 GHz)
- TP-D01-032-E020-V2 E-Field probe calibration procedure
- D22-012-Tissue dielectric tissue calibration procedure
- D28-002-Dipole procedure for validation of SAR system using a dipole
- IEEE 1309 Standard for Calibration of Electromagnetic Field Sensors and Probes, Excluding Antennas, from 9kHz to 40GHz

Page 2 of 10

This page has been reviewed for content and attested to on Page 2 of this document.

NCL Calibration Laboratories

Division of APREL Inc.

Conditions

Probe 500-00283 was a recalibration.

Ambient Temperature of the Laboratory: 22 °C +/- 1.5°C
Temperature of the Tissue: 21 °C +/- 1.5°C
Relative Humidity: < 60%

Primary Measurement Standards

Instrument	Serial Number	Cal due date
Tektronix USB Power Meter	11C940	May 14, 2015
Signal Generator HP 83640B	3844A00689	Feb 12, 2015

Secondary Measurement Standards

Network Analyzer Anritsu 37347C	002106	Feb. 20, 2015
---------------------------------	--------	---------------

Attestation

The below named signatories have conducted the calibration and review of the data which is presented in this calibration report.

We the undersigned attest that to the best of our knowledge the calibration of this subject has been accurately conducted and that all information contained within the results pages have been reviewed for accuracy.



Art Brennan, Quality Manager



Dan Brooks, Test Engineer

NCL Calibration Laboratories

Division of APREL Inc.

Probe Summary

Probe Type:	E-Field Probe E020
Serial Number:	500-00283
Frequency:	As presented on page 5
Sensor Offset:	1.56
Sensor Length:	2.5
Tip Enclosure:	Composite*
Tip Diameter:	< 2.9 mm
Tip Length:	55 mm
Total Length:	289 mm

*Resistive to recommended tissue recipes per IEEE-1528

Sensitivity in Air

Channel X:	1.2 $\mu\text{V}/(\text{V}/\text{m})^2$
Channel Y:	1.2 $\mu\text{V}/(\text{V}/\text{m})^2$
Channel Z:	1.2 $\mu\text{V}/(\text{V}/\text{m})^2$
Diode Compression Point:	95 mV

Page 4 of 10

This page has been reviewed for content and attested to on Page 2 of this document.

NCL Calibration Laboratories

Division of APREL Inc.

Calibration for Tissue (Head H, Body B)

Frequency	Tissue Type	Measured Epsilon	Measured Sigma	Standard Uncertainty (%)	Calibration Frequency Range (MHz)	Conversion Factor
450 H	Head	43.59	0.86	3.5	±50	5.7
450 B	Body	56.74	0.94	3.5	±50	5.8
750 H	Head	42.98	0.92	3.5	±50	6.0
750 B	Body	43.05	0.93	3.5	±50	5.5
835 H	Head	43.42	0.94	3.5	±50	5.9
835 B	Body	55.77	1.01	3.5	±50	5.9
900 H	Head	41.87	1.06	3.5	±50	6.0
900 B	Body	55.62	1.05	3.5	±50	5.9
1450 H	Head	X	X	X	X	X
1450 B	Body	X	X	X	X	X
1500 H	Head	X	X	X	X	X
1500 B	Body	X	X	X	X	X
1640 H	Head	X	X	X	X	X
1640 B	Body	X	X	X	X	X
1750 H	Head	38.23	1.38	3.5	±75	5.4
1750 B	Body	52.86	1.54	3.5	±75	5.3
1800 H	Head	X	X	X	X	X
1800 B	Body	X	X	X	X	X
1900 H	Head	40.20	1.38	3.5	±75	4.8
1900 B	Body	52.63	1.46	3.5	±75	4.5
2000 H	Head	X	X	X	X	X
2000 B	Body	X	X	X	X	X
2100 H	Head	X	X	X	X	X
2100 B	Body	X	X	X	X	X
2300 H	Head	X	X	X	X	X
2300 B	Body	X	X	X	X	X
2450 H	Head	37.26	1.84	3.5	±75	4.9
2450 B	Body	53.61	1.9	3.5	±75	4.3
3000 H	Head	X	X	X	X	X
3000 B	Body	X	X	X	X	X
3600 H	Head	37.49	3.16	3.5	±100	4.5
3600 B	Body	49.94	3.86	3.5	±100	4.0
5250 H	Head	35.51	4.78	3.5	±100	3.0
5250 B	Body	47.54	5.11	3.5	±100	2.8
5600 H	Head	36.05	5.15	3.5	±100	2.8
5600 B	Body	46.49	5.72	3.5	±100	2.2
5800 H	Head	45.99	6.01	3.5	±100	3.2
5800 B	Body	35.6	5.37	3.5	±100	2.5

NCL Calibration Laboratories

Division of APREL Inc.

Boundary Effect:

Uncertainty resulting from the boundary effect is less than 2.1% for the distance between the tip of the probe and the tissue boundary, when less than 0.58mm.

Spatial Resolution:

The spatial resolution uncertainty is less than 1.5% for 4.9mm diameter probe.
The spatial resolution uncertainty is less than 1.0% for 2.5mm diameter probe.

DAQ-PAQ Contribution

To minimize the uncertainty calculation all tissue sensitivity values were calculated using a load impedance of 5 M Ω .

Page 6 of 10

This page has been reviewed for content and attested to on Page 2 of this document.

NCL Calibration Laboratories

Division of APREL Inc.

Receiving Pattern Air

