

SAR EVALUATION REPORT

For

Nexpro International Limitada

Guadalupe, Barrio Tournon, Frente Al Hotel Villas, Oficinas Del Bufete Facio Y Canas,
San Jose-Goicoechea Costa Rica

FCC ID: ZYPFLARE

Report Type: Original Report	Product Type: LTE Mobile phone
Test Engineer: Terry XiaHou	<i>Terry XiaHou</i>
Report Number: RSZ150930002-20	
Report Date: 2015-10-26	
Reviewed By: SAR Engineer	<i>Bell Hu</i>
Prepared By: Bay Area Compliance Laboratories Corp. (Shenzhen) 6/F, the 3rd Phase of WanLi Industrial Building, ShiHua Road, FuTian Free Trade Zone Shenzhen, Guangdong, China Tel: +86-755-33320018 Fax: +86-755-33320008 www.baclcorp.com.cn	

Attestation of Test Results		
EUT Information	Company Name	Nexpro International Limitada
	EUT Description	LTE Mobile phone
	FCC ID	ZYPFLARE
	Model Number	Flare
	Test Date	2015-10-06
Frequency	Max. SAR Level(s) Reported	Limit(W/Kg)
GSM 850	0.758 W/kg 1g Head SAR 1.273 W/kg 1g Body SAR	1.6
PCS 1900	0.123 W/kg 1g Head SAR 0.189 W/kg 1g Body SAR	
WCDMA 850	0.365 W/kg 1g Head SAR 0.543 W/kg 1g Body SAR	
WCDMA 1900	0.370 W/kg 1g Head SAR 0.556 W/kg 1g Body SAR	
LTE Band 2	0.493 W/kg 1g Head SAR 0.753 W/kg 1g Body SAR	
LTE Band 4	0.343 W/kg 1g Head SAR 0.528 W/kg 1g Body SAR	
Simultaneous	1.107 W/kg 1g Head SAR 1.447 W/kg 1g Body SAR	
Hotspot	1.447 W/kg 1g Body SAR	
Applicable Standards	ANSI / IEEE C95.1 : 2005 IEEE Standard for Safety Levels with Respect to Human Exposure to Radio Frequency Electromagnetic Fields,3 kHz to 300 GHz.	
	ANSI / IEEE C95.3 : 2002 IEEE Recommended Practice for Measurements and Computations of Radio Frequency Electromagnetic Fields With Respect to Human Exposure to Such Fields,100 kHz—300 GHz.	
	FCC 47 CFR part 2.1093 Radiofrequency radiation exposure evaluation: portable devices	
	IEEE1528:2013 IEEE Recommended Practice for Determining the Peak Spatial-Average Specific Absorption Rate (SAR) in the Human Head from Wireless Communications Devices: Measurement Techniques	
	IEC 62209-2:2010 Human exposure to radio frequency fields from hand-held and body-mounted wireless communication devices-Human models, instrumentation, and procedures-Part 2: Procedure to determine the specific absorption rate (SAR) for wireless communication devices used in close proximity to the human body (frequency range of 30 MHz to 6 GHz)	
	KDB procedures KDB 447498 D01 General RF Exposure Guidance v05r02. KDB 648474 D04 Handset SAR v01r02. KDB 865664 D01 SAR measurement 100 MHz to 6 GHz v01r03 KDB 865664 D02 RF Exposure Reporting v01r01 KDB 941225 D01 3G SAR Procedures v03 KDB 941225 D05 SAR for LTE Devices v02r03 KDB 941225 D06 Hotspot Mode v02	

Note: This wireless device has been shown to be capable of compliance for localized specific absorption rate (SAR) for General Population/Uncontrolled Exposure limits specified in ANSI/IEEE Standards and has been tested in accordance with the measurement procedures specified in IEEE 1528-2013 and RF exposure KDB procedures.

The results and statements contained in this report pertain only to the device(s) evaluated.

TABLE OF CONTENTS

DOCUMENT REVISION HISTORY	6
EUT DESCRIPTION	7
TECHNICAL SPECIFICATION	7
REFERENCE, STANDARDS, AND GUIDELINES	8
SAR LIMITS	9
FACILITIES	10
DESCRIPTION OF TEST SYSTEM	11
EQUIPMENT LIST AND CALIBRATION	18
EQUIPMENTS LIST & CALIBRATION INFORMATION	18
SAR MEASUREMENT SYSTEM VERIFICATION	19
LIQUID VERIFICATION	19
SYSTEM ACCURACY VERIFICATION	24
SAR SYSTEM VALIDATION DATA	25
EUT TEST STRATEGY AND METHODOLOGY	37
TEST POSITIONS FOR DEVICE OPERATING NEXT TO A PERSON’S EAR	37
CHEEK/TOUCH POSITION	38
EAR/TILT POSITION	38
TEST POSITIONS FOR BODY-WORN AND OTHER CONFIGURATIONS	39
SAR EVALUATION PROCEDURE	40
TEST METHODOLOGY	40
CONDUCTED OUTPUT POWER MEASUREMENT	41
PROVISION APPLICABLE	41
TEST PROCEDURE	41
RADIO CONFIGURATION	41
MAXIMUM OUTPUT POWER AMONG PRODUCTION UNITS	47
TEST RESULTS:	48
SAR MEASUREMENT RESULTS	57
SAR TEST DATA	57
SAR SIMULTANEOUS TRANSMISSION DESCRIPTION	66
SAR PLOTS (SUMMARY OF THE HIGHEST SAR VALUES)	71
APPENDIX A MEASUREMENT UNCERTAINTY	83
APPENDIX B – PROBE CALIBRATION CERTIFICATES	85
APPENDIX C DIPOLE CALIBRATION CERTIFICATES	95
APPENDIX D EUT TEST POSITION PHOTOS	122
LIQUID DEPTH \geq 15CM	122
BODY-WORN BACK SETUP PHOTO (10MM)	122
BODY-WORN RIGHT SETUP PHOTO (10MM)	123
BODY-WORN LEFT SETUP PHOTO (10MM)	123
BODY-WORN BOTTOM SETUP PHOTO (10MM)	124
LEFT HEAD TOUCH SETUP PHOTO	124
LEFT HEAD TILT SETUP PHOTO	125
RIGHT HEAD TOUCH SETUP PHOTO	125
RIGHT HEAD TILT SETUP PHOTO	126
APPENDIX E EUT PHOTOS	127
EUT – FRONT VIEW	127
EUT – BACK VIEW	127

EUT –LEFT SIDE VIEW	128
EUT – RIGHT SIDE VIEW	128
EUT – TOP VIEW	129
EUT – BOTTOM VIEW.....	129
EUT – UNCOVER VIEW.....	130
APPENDIX F INFORMATIVE REFERENCES	131

DOCUMENT REVISION HISTORY

Revision Number	Report Number	Description of Revision	Date of Revision
0	RSZ150930002-20	Original Report	2015-10-26

EUT DESCRIPTION

This report has been prepared on behalf of Nexpro International Limitada and their product, FCC ID: ZYPFLARE, Model: Flare or the EUT (Equipment under Test) as referred to in the rest of this report.

Technical Specification

Product Type	Portable
Exposure Category:	Population / Uncontrolled
Antenna Type(s):	Internal Antenna
Body-Worn Accessories:	Headset
Face-Head Accessories:	None
Multi-slot Class:	Class12
Operation Mode :	GSM Voice, EGPRS/GPRS Data, WCDMA(Rel99, HSUPA, HSDPA,DC-HSDPA,HSPA+),LTE, Wi-Fi and Bluetooth
Frequency Band:	GSM 850 : 824-849 MHz(TX) ; 869-894 MHz(RX) PCS 1900: 1850-1910 MHz(TX) ; 1930-1990 MHz(RX) WCDMA 850: 824-849 MHz(TX) ; 869-894 MHz(RX) WCDMA 1900: 1850-1910 MHz(TX) ; 1930-1990 MHz(RX) LTE Band 2: 1850-1910 MHz(TX) ; 1930-1990 MHz(RX) LTE Band 4: 1710-1755 MHz(TX) ; 2110-2155 MHz(RX) Wi-Fi(802.11b/g/n20): 2412 MHz-2462 MHz Wi-Fi(802.11n40): 2422 MHz-2452 MHz Bluetooth : 2402 MHz-2480 MHz BLE:2402 MHz-2480 MHz
Conducted RF Power:	GSM 850 : 32.78 dBm PCS 1900: 28.49 dBm WCDMA 850: 22.71 dBm WCDMA 1900: 22.89 dBm LTE Band 2: 22.68 dBm LTE Band 4: 22.53 dBm Wi-Fi(802.11b/g/n20): 9.17 dBm Wi-Fi(802.11n40) : 9.01 dBm Bluetooth: 4.56 dBm BLE: -5.96 dBm
Dimensions (L*W*H):	145 mm (L) × 72 mm (W) × 9 mm (H)
Power Source:	3.7 V _{DC} Rechargeable Battery
Normal Operation:	Head and Body-worn

REFERENCE, STANDARDS, AND GUIDELINES

FCC:

The Report and Order requires routine SAR evaluation prior to equipment authorization of portable transmitter devices, including portable telephones. For consumer products, the applicable limit is 1.6 mW/g as recommended by the ANSI/IEEE standard C95.1-1992 [6] for an uncontrolled environment (Paragraph 65). According to the Supplement C of OET Bulletin 65 "Evaluating Compliance with FCC Guide-lines for Human Exposure to Radio frequency Electromagnetic Fields", released on Jun 29, 2001 by the FCC, the device should be evaluated at maximum output power (radiated from the antenna) under "worst-case" conditions for normal or intended use, incorporating normal antenna operating positions, device peak performance frequencies and positions for maximum RF energy coupling.

This report describes the methodology and results of experiments performed on wireless data terminal. The objective was to determine if there is RF radiation and if radiation is found, what is the extent of radiation with respect to safety limits. SAR (Specific Absorption Rate) is the measure of RF exposure determined by the amount of RF energy absorbed by human body (or its parts) – to determine how the RF energy couples to the body or head which is a primary health concern for body worn devices. The limit below which the exposure to RF is considered safe by regulatory bodies in North America is 1.6 mW/g average over 1 gram of tissue mass.

CE:

The order requires routine SAR evaluation prior to equipment authorization of portable transmitter devices, including portable telephones. For consumer products, the applicable limit is 2 mW/g as recommended by EN62209-1 for an uncontrolled environment. According to the Standard, the device should be evaluated at maximum output power (radiated from the antenna) under "worst-case" conditions for normal or intended use, incorporating normal antenna operating positions, device peak performance frequencies and positions for maximum RF energy coupling.

This report describes the methodology and results of experiments performed on wireless data terminal. The objective was to determine if there is RF radiation and if radiation is found, what is the extent of radiation with respect to safety limits. SAR (Specific Absorption Rate) is the measure of RF exposure determined by the amount of RF energy absorbed by human body (or its parts) – to determine how the RF energy couples to the body or head which is a primary health concern for body worn devices. The limit below which the exposure to RF is considered safe by regulatory bodies in Europe is 2 mW/g average over 10 gram of tissue mass.

The test configurations were laid out on a specially designed test fixture to ensure the reproducibility of measurements. Each configuration was scanned for SAR. Analysis of each scan was carried out to characterize the above effects in the device.

SAR Limits

FCC Limit (1g Tissue)

EXPOSURE LIMITS	SAR (W/kg)	
	(General Population / Uncontrolled Exposure Environment)	(Occupational / Controlled Exposure Environment)
Spatial Average (averaged over the whole body)	0.08	0.4
Spatial Peak (averaged over any 1 g of tissue)	1.60	8.0
Spatial Peak (hands/wrists/feet/ankles averaged over 10 g)	4.0	20.0

CE Limit (10g Tissue)

EXPOSURE LIMITS	SAR (W/kg)	
	(General Population / Uncontrolled Exposure Environment)	(Occupational / Controlled Exposure Environment)
Spatial Average (averaged over the whole body)	0.08	0.4
Spatial Peak (averaged over any 10 g of tissue)	2.0	10
Spatial Peak (hands/wrists/feet/ankles averaged over 10 g)	4.0	20.0

Population/Uncontrolled Environments are defined as locations where there is the exposure of individual who have no knowledge or control of their exposure.

Occupational/Controlled Environments are defined as locations where there is exposure that may be incurred by people who are aware of the potential for exposure (i.e. as a result of employment or occupation).

General Population/Uncontrolled environments Spatial Peak limit 1.6W/kg (FCC) & 2 W/kg (CE) applied to the EUT.

FACILITIES

The test site used by Bay Area Compliance Laboratories Corp. (Shenzhen) to collect data is located at 6/F, the 3rd Phase of WanLi Industrial Building, Shi Hua Road, Fu Tian Free Trade Zone, Shenzhen, Guangdong, P.R. of China

DESCRIPTION OF TEST SYSTEM

These measurements were performed with ALSAS 10 Universal Integrated SAR Measurement system from APREL Laboratories.

ALSAS-10U System Description

ALSAS-10-U is fully compliant with the technical and scientific requirements of IEEE 1528, IEC 62209, CENELEC, ARIB, ACA, and the Federal Communications Commission. The system comprises of a six axes articulated robot which utilizes a dedicated controller. ALSAS-10U uses the latest methodologies. And FDTD modeling to provide a platform which is repeatable with minimum uncertainty.

Applications

Predefined measurement procedures compliant with the guidelines of CENELEC, IEEE, IEC, FCC, etc are utilized during the assessment for the device. Automatic detection for all SAR maxima are embedded within the core architecture for the system, ensuring that peak locations used for centering the zoom scan are within a 1mm resolution and a 0.05mm repeatable position. System operation range currently available up-to 6 GHz in simulated tissue.

Area Scans

Area scans are defined prior to the measurement process being executed with a user defined variable spacing between each measurement point (integral) allowing low uncertainty measurements to be conducted. Scans defined for FCC applications utilize a 10mm² step integral, with 1mm interpolation used to locate the peak SAR area used for zoom scan assessments.

Where the system identifies multiple SAR peaks (which are within 25% of peak value) the system will provide the user with the option of assessing each peak location individually for zoom scan averaging.

Zoom Scan (Cube Scan Averaging)

The averaging zoom scan volume utilized in the ALSAS-10U software is in the shape of a cube and the side dimension of a 1 g or 10 g mass is dependent on the density of the liquid representing the simulated tissue. A density of 1000 kg/m³ is used to represent the head and body tissue density and not the phantom liquid density, in order to be consistent with the definition of the liquid dielectric properties, i.e. the side length of the 1 g cube is 10mm, with the side length of the 10 g cube 21,5mm.

When the cube intersects with the surface of the phantom, it is oriented so that 3 vertices touch the surface of the shell or the center of a face is tangent to the surface. The face of the cube closest to the surface is modified in order to conform to the tangent surface.

The zoom scan integer steps can be user defined so as to reduce uncertainty, but normal practice for typical test applications (including FCC) utilize a physical step of 5x5x8 (8mmx8mmx5mm) providing a volume of 32mm³ in the X & Y axis, and 35mm in the Z axis.



ALSAS-10U Interpolation and Extrapolation Uncertainty

The overall uncertainty for the methodology and algorithms the used during the SAR calculation was evaluated using the data from IEEE 1528 based on the example f3 algorithm:

$$f_3(x, y, z) = A \frac{a^2}{\frac{a^2}{4} + x'^2 + y'^2} \cdot \left(e^{-\frac{2z}{a}} + \frac{a^2}{2(a + 2z)^2} \right)$$

Isotropic E-Field Probe

The isotropic E-Field probe has been fully calibrated and assessed for isotropicity, and boundary effect within a controlled environment. Depending on the frequency for which the probe is calibrated the method utilized for calibration will change.

The E-Field probe utilizes a triangular sensor arrangement as detailed in the diagram below:

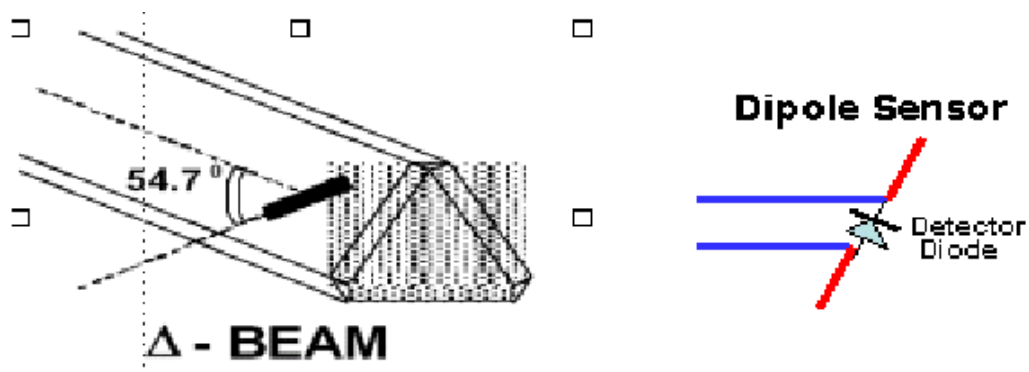

SAR is assessed with a calibrated probe which moves at a default height of 5mm from the center of the diode, which is mounted to the sensor, to the phantom surface (in the Z Axis). The 5mm offset height has been selected so as to minimize any resultant boundary effect due to the probe being in close proximity to the phantom surface.

The following algorithm is an example of the function used by the system for linearization of the output from the probe when measuring complex modulation schemes.

$$V_i = U_i + U_i^2 \cdot \frac{cf}{dcp_i}$$

Isotropic E-Field Probe Specification

Calibration Method	Frequency Dependent Below 1 GHz Calibration in air performed in a TEM Cell Above 1 GHz Calibration in air performed in waveguide
Sensitivity	0.70 $\mu\text{V}/(\text{V}/\text{m})^2$ to 0.85 $\mu\text{V}/(\text{V}/\text{m})^2$
Dynamic Range	0.0005 W/kg to 100 W/kg
Isotropic Response	Better than 0.1 dB
Diode Compression Point (DCP)	Calibration for Specific Frequency
Probe Tip Diameter	< 2.9 mm
Sensor Offset	1.56 (+/- 0.02 mm)
Probe Length	289 mm
Video Bandwidth	@ 500 Hz: 1 dB @ 1.02 kHz: 3 dB
Boundary Effect	Less than 2.1% for distance greater than 0.58 mm
Spatial Resolution	The spatial resolution uncertainty is less than 1.5% for 4.9mm diameter probe. The spatial resolution uncertainty is less than 1.0% for 2.5mm diameter probe

Boundary Detection Unit and Probe Mounting Device

ALSAS-10U incorporates a boundary detection unit with a sensitivity of 0.05mm for detecting all types of surfaces. The robust design allows for detection during probe tilt (probe normalize) exercises, and utilizes a second stage emergency stop. The signal electronics are fed directly into the robot controller for high accuracy surface detection in lateral and axial detection modes (X, Y, & Z).

The probe is mounted directly onto the Boundary Detection unit for accurate tooling and displacement calculations controlled by the robot kinematics. The probe is connect to an isolated probe interconnect where the output stage of the probe is fed directly into the amplifier stage of the Daq-Paq.

Daq-Paq (Analog to Digital Electronics)

ALSAS-10U incorporates a fully calibrated Daq-Paq (analog to digital conversion system) which has a 4 channel input stage, sent via a 2 stage auto-set amplifier module. The input signal is amplified accordingly so as to offer a dynamic range from 5 μV to 800mV. Integration of the fields measured is carried out at board level utilizing a Co-Processor which then sends the measured fields down into the main computational module in digitized form via an RS232 communications port. Probe linearity and duty cycle compensation is carried out within the main Daq-Paq module.

ADC	12 Bit
Amplifier Range	20 mV to 200 mV and 150 mV to 800 mV
Field Integration	Local Co-Processor utilizing proprietary integration algorithms
Number of Input Channels	4 in total 3 dedicated and 1 spare
Communication	Packet data via RS232

Axis Articulated Robot

ALSAS-10U utilizes a six axis articulated robot, which is controlled using a Pentium based real-time movement controller. The movement kinematics engine utilizes proprietary (Thermo CRS) interpolation and extrapolation algorithms, which allow full freedom of movement for each of the six joints within the working envelope. Utilization of joint 6 allows for full probe rotation with a tolerance better than 0.05mm around the central axis.



Robot/Controller Manufacturer	Thermo CRS
Number of Axis	Six independently controlled axis
Positioning Repeatability	0.05 mm
Controller Type	Single phase Pentium based C500C
Robot Reach	710 mm
Communication	RS232 and LAN compatible

ALSAS Universal Workstation

ALSAS Universal workstation allows for repeatability and fast adaptability. It allows users to do calibration, testing and measurements using different types of phantoms with one set up, which significantly speeds up the measurement process.

Universal Device Positioner

The universal device positioner allows complete freedom of movement of the EUT. Developed to hold a EUT in a free-space scenario any additional loading attributable to the material used in the construction of the positioner has been eliminated. Repeatability has been enhanced through the linear scales which form the design used to indicate positioning for any given test scenario in all major axes. A 15° tilt indicator is included for the of aid cheek to tilt movements for head SAR analysis. Overall uncertainty for measurements have been reduced due to the design of the Universal device positioner, which allows positioning of a device in as near to a free-space scenario as possible, and by providing the means for complete repeatability.



Phantom Types

The ALSAS-10U allows the integration of multiple phantom types. SAM Phantoms fully compliant with IEEE 1528, Universal Phantom, and Universal Flat.

APREL SAM Phantoms

The SAM phantoms developed using the IEEE SAM CAD file. They are fully compliant with the requirements for both IEEE 1528 and FCC Supplement C. Both the left and right SAM phantoms are interchangeable, transparent and include the IEEE 1528 grid with visible NF and MB lines.

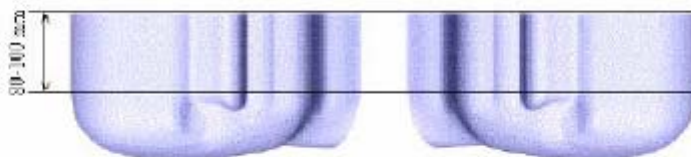

APREL Laboratories Universal Phantom

The Universal Phantom is used on the ALSAS-10U as a system validation phantom. The Universal Phantom has been fully validated both experimentally from 800MHz to 6GHz and numerically using XFDTD numerical software.

The shell thickness is 2mm overall, with a 4mm spacer located at the NF/MB intersection providing an overall thickness of 6mm in line with the requirements of IEEE-1528.

The design allows for fast and accurate measurements, of handsets, by allowing the conservative SAR to be evaluated at on frequency for both left and right head experiments in one measurement.

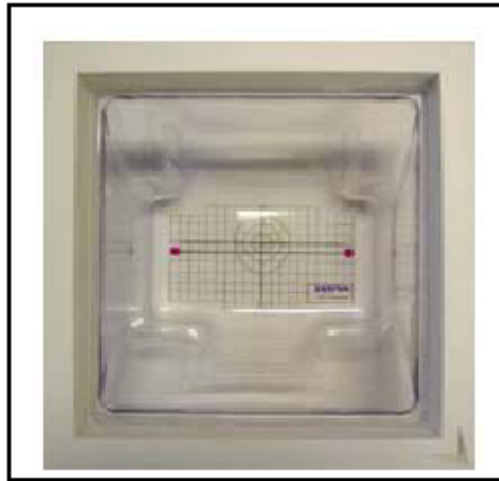

Tissue Dielectric Parameters for Head and Body Phantoms

The head tissue dielectric parameters recommended by the IEEE SCC-34/SC-2 in P1528 have been incorporated in the following table. These head parameters are derived from planar layer models simulating the highest expected SAR for the dielectric properties and tissue thickness variations in a human head. Other head and body tissue parameters that have not been specified in P1528 are derived from the tissue dielectric parameters computed from the 4-Cole-Cole equations described in Reference [12] and extrapolated according to the head parameters specified in P1528.

Ingredients (% by weight)	Frequency (MHz)									
	450		835		915		1900		2450	
Tissue Type	Head	Body	Head	Body	Head	Body	Head	Body	Head	Body
Water	38.56	51.16	41.45	52.4	41.05	56.0	54.9	40.4	62.7	73.2
Salt (Nacl)	3.95	1.49	1.45	1.4	1.35	0.76	0.18	0.5	0.5	0.04
Sugar	56.32	46.78	56.0	45.0	56.5	41.76	0.0	58.0	0.0	0.0
HEC	0.98	0.52	1.0	1.0	1.0	1.21	0.0	1.0	0.0	0.0
Bactericide	0.19	0.05	0.1	0.1	0.1	0.27	0.0	0.1	0.0	0.0
Triton x-100	0.0	0.0	0.0	0.0	0.0	0.0	0.0	0.0	36.8	0.0
DGBE	0.0	0.0	0.0	0.0	0.0	0.0	44.92	0.0	0.0	26.7
Dielectric Constant	43.42	58.0	42.54	56.1	42.0	56.8	39.9	54.0	39.8	52.5
Conductivity (s/m)	0.85	0.83	0.91	0.95	1.0	1.07	1.42	1.45	1.88	1.78

Recommended Tissue Dielectric Parameters for Head and Body

Frequency (MHz)	Head Tissue		Body Tissue	
	ϵ_r	σ (S/m)	ϵ_r	σ (S/m)
150	52.3	0.76	61.9	0.80
300	45.3	0.87	58.2	0.92
450	43.5	0.87	56.7	0.94
835	41.5	0.90	55.2	0.97
900	41.5	0.97	55.0	1.05
915	41.5	0.98	55.0	1.06
1450	40.5	1.20	54.0	1.30
1610	40.3	1.29	53.8	1.40
1800-2000	40.0	1.40	53.3	1.52
2450	39.2	1.80	52.7	1.95
3000	38.5	2.40	52.0	2.73
5800	35.3	5.27	48.2	6.00

EQUIPMENT LIST AND CALIBRATION

Equipments List & Calibration Information

Equipment	Model	Calibration Date	Calibration Due Date	S/N
CRS F3 robot	ALS-F3	N/A	N/A	RAF0805352
CRS F3 Software	ALS-F3-SW	N/A	N/A	N/A
CRS C500C controller	ALS-C500	N/A	N/A	RCF0805379
Probe mounting device & Boundary Detection Sensor System	ALS-PMDPS-3	N/A	N/A	120-00270
Universal Work Station	ALS-UWS	N/A	N/A	100-00157
Data Acquisition Package	ALS-DAQ-PAQ-3	2014-10-14	2015-10-14	110-00212
Miniature E-Field Probe	ALS-E-020	2014-10-14	2015-10-14	500-00283
Dipole, 835MHz	ALS-D-835-S-2	2014-10-08	2017-10-08	180-00558
Dipole, 1750MHz	ALS-D-1750-S-2	2013-10-08	2013-10-08	198-00304
Dipole, 1900MHz	ALS-D-1900-S-2	2014-10-09	2017-10-09	210-00710
Dipole Spacer	ALS-DS-U	N/A	N/A	250-00907
Device holder/Positioner	ALS-H-E-SET-2	N/A	N/A	170-00510
Left ear SAM phantom	ALS-P-SAM-L	N/A	N/A	130-00311
Right ear SAM phantom	ALS-P-SAM-R	N/A	N/A	140-00359
UniPhantom	ALS-P-UP-1	N/A	N/A	150-00413
Simulated Tissue 835 MHz Head	ALS-TS-835-H	Each Time	Each Time	270-01002
Simulated Tissue 835 MHz Body	ALS-TS-835-B	Each Time	Each Time	270-02101
Simulated Tissue 1750 MHz Head	ALS-TS-1750-H	Each Time	Each Time	295-01103
Simulated Tissue 1750 MHz Body	ALS-TS-1750-B	Each Time	Each Time	295-02102
Simulated Tissue 1900 MHz Head	ALS-TS-1900-H	Each Time	Each Time	295-01103
Simulated Tissue 1900 MHz Body	ALS-TS-1900-B	Each Time	Each Time	295-02102
Directional couple	DC6180A	N/A	N/A	0325849
Power Amplifier	5S1G4	N/A	N/A	71377
Attenuator	3dB	N/A	N/A	5402
Dielectric probe kit	HP85070B	2015-06-13	2016-06-13	US33020324
Network analyzer	8752C	2015-06-03	2016-06-03	3410A02356
Synthesized Sweeper	HP 8341B	2015-06-03	2016-06-03	2624A00116
UNIVERSAL RADIO COMMUNICATION TESTER	CMU200	2014-11-23	2015-11-23	106891
WIDEBAND RADIO COMMUNICATION TESTER	CMW500	2015-04-19	2016-04-19	114772
8960 Series 10 Wireless Communication Test Set	E5515C	MY50266471	2015-01-13	2016-01-13
EMI Test Receiver	ESCI	2015-06-13	2016-06-13	101746

SAR MEASUREMENT SYSTEM VERIFICATION

Liquid Verification

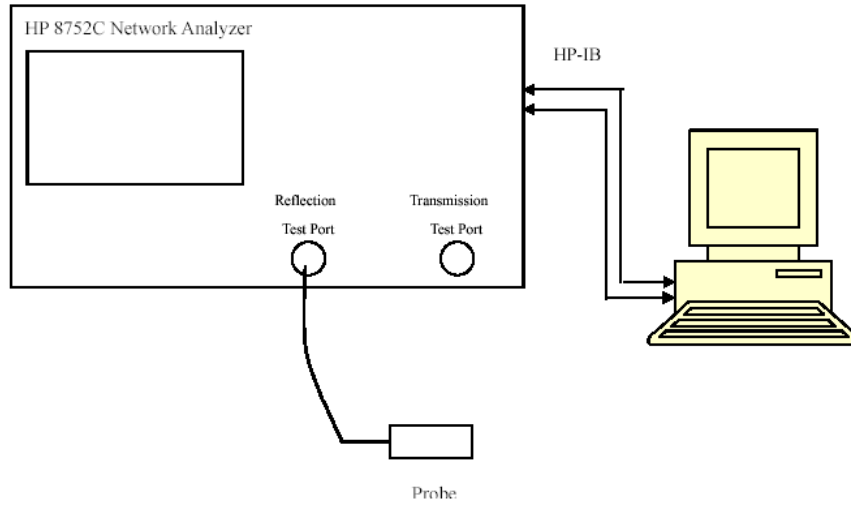

Liquid Verification Setup Block Diagram

Liquid Verification Results

Frequency	Liquid Type	Liquid Parameter		Target Value		Delta (%)		Tolerance (%)
		ϵ_r	σ (S/m)	ϵ_r	σ (S/m)	$\Delta\epsilon_r$	$\Delta\sigma$ (S/m)	
824.2	Head	41.05	0.90	41.50	0.90	-1.084	0.000	±5
	Body	53.82	0.95	55.20	0.97	-2.500	-2.062	±5
826.4	Head	41.10	0.91	41.50	0.90	-0.964	1.111	±5
	Body	53.86	0.95	55.20	0.97	-2.428	-2.062	±5
836.6	Head	41.08	0.92	41.50	0.90	-1.012	2.222	±5
	Body	53.80	0.96	55.20	0.97	-2.536	-1.031	±5
846.6	Head	41.01	0.92	41.50	0.90	-1.181	2.222	±5
	Body	53.80	0.97	55.20	0.97	-2.536	0.000	±5
848.8	Head	41.02	0.92	41.50	0.90	-1.157	2.222	±5
	Body	53.84	0.97	55.20	0.97	-2.464	0.000	±5
1720.0	Head	39.21	1.36	40.08	1.37	-2.171	-0.730	±5
	Body	51.93	1.49	53.43	1.49	-2.807	0.000	±5
1732.5	Head	39.25	1.39	40.08	1.37	-2.071	1.460	±5
	Body	51.87	1.51	53.43	1.49	-2.920	1.342	±5
1745.0	Head	39.22	1.39	40.08	1.37	-2.146	1.460	±5
	Body	51.88	1.52	53.43	1.49	-2.901	2.013	±5
1850.2	Head	39.59	1.37	40.00	1.40	-1.025	-2.143	±5
	Body	52.00	1.50	53.30	1.52	-2.439	-1.316	±5
1852.4	Head	39.74	1.36	40.00	1.40	-0.650	-2.857	±5
	Body	52.04	1.49	53.30	1.52	-2.364	-1.974	±5
1860.0	Head	39.66	1.39	40.00	1.40	-0.850	-0.714	±5
	Body	52.03	1.50	53.30	1.52	-2.383	-1.316	±5
1880.0	Head	39.70	1.39	40.00	1.40	-0.750	-0.714	±5
	Body	51.88	1.52	53.30	1.52	-2.664	0.000	±5
1900.0	Head	39.56	1.40	40.00	1.40	-1.100	0.000	±5
	Body	51.88	1.53	53.30	1.52	-2.664	0.658	±5
1907.6	Head	39.73	1.42	40.00	1.40	-0.675	1.429	±5
	Body	51.95	1.54	53.30	1.52	-2.533	1.316	±5
1909.8	Head	39.68	1.42	40.00	1.40	-0.800	1.429	±5
	Body	51.85	1.55	53.30	1.52	-2.720	1.974	±5

*Liquid Verification was performed on 2015-10-06.

Please refer to the following tables.

835 MHz Head				835 MHz Body		
Frequency (MHz)	e'	e''		Frequency (MHz)	e'	e''
824.0	41.0508	19.7364		824.0	53.8157	20.6737
824.5	41.0616	19.7457		824.5	53.8655	20.6535
825.0	41.0958	19.7108		825.0	53.7795	20.6902
825.5	41.0107	19.7309		825.5	53.8287	20.6958
826.0	41.0323	19.7694		826.0	53.8313	20.7076
826.5	41.1043	19.7225		826.5	53.8573	20.6473
827.0	41.0630	19.6839		827.0	53.8182	20.6803
827.5	41.0456	19.6700		827.5	53.7873	20.6215
828.0	41.0716	19.7159		828.0	53.8559	20.6626
828.5	41.0279	19.7275		828.5	53.8156	20.6311
829.0	41.0428	19.7002		829.0	53.8308	20.7042
829.5	41.0414	19.7279		829.5	53.8251	20.6263
830.0	41.0165	19.7646		830.0	53.7935	20.6347
830.5	41.0503	19.7584		830.5	53.7735	20.6667
831.0	41.0269	19.7490		831.0	53.8227	20.6905
831.5	41.0912	19.7294		831.5	53.8040	20.6227
832.0	41.0916	19.7275		832.0	53.7987	20.6185
832.5	41.0247	19.7372		832.5	53.7671	20.7102
833.0	41.0875	19.7397		833.0	53.8042	20.7053
833.5	41.0515	19.6822		833.5	53.8407	20.6519
834.0	41.0535	19.7334		834.0	53.8011	20.6353
834.5	41.0369	19.7261		834.5	53.7718	20.6284
835.0	41.0285	19.6784		835.0	53.8089	20.6154
835.5	41.0787	19.7053		835.5	53.7981	20.6764
836.0	41.0475	19.7467		836.0	53.8566	20.7031
836.5	41.0250	19.7261		836.5	53.7788	20.6902
837.0	41.0361	19.7700		837.0	53.8520	20.7024
837.5	41.0186	19.7600		837.5	53.8006	20.6293
838.0	41.0857	19.7196		838.0	53.8458	20.6407
838.5	41.0845	19.7670		838.5	53.7666	20.6925
839.0	41.0107	19.6788		839.0	53.8732	20.6925
839.5	41.0042	19.7416		839.5	53.7814	20.6482
840.0	41.0016	19.3846		840.0	53.8611	20.6313
840.5	41.0622	19.4028		840.5	53.8680	20.6881
841.0	41.0940	19.4643		841.0	53.7852	20.6667
841.5	41.1042	19.4534		841.5	53.8576	20.6678
842.0	41.0952	19.4468		842.0	53.8475	20.6245
842.5	41.0808	19.4050		842.5	53.7762	20.6744
843.0	41.0460	19.4061		843.0	53.7682	20.6674
843.5	41.0711	19.3897		843.5	53.7870	20.6278
844.0	41.0952	19.4636		844.0	53.7844	20.7062
844.5	41.0825	19.4706		844.5	53.8502	20.6292
845.0	41.0191	19.4485		845.0	53.8599	20.6931
845.5	41.0273	19.3728		845.5	53.7999	20.6157
846.0	41.0334	19.3833		846.0	53.7660	20.6403
846.5	41.0103	19.4563		846.5	53.7981	20.6821
847.0	41.0416	19.3863		847.0	53.8454	20.6538
847.5	41.0093	19.4054		847.5	53.8480	20.6600
848.0	41.0431	19.4698		848.0	53.8211	20.6131
848.5	41.0913	19.3879		848.5	53.8050	20.6328
849.0	41.0206	19.4223		849.0	53.8434	20.6320

1750 MHz Head				1750 MHz Body		
Frequency (MHz)	e'	e''		Frequency (MHz)	e'	e''
1710.0	39.3216	14.4903		1710.0	51.8870	15.6634
1711.5	39.4525	14.0922		1711.5	52.0898	15.5613
1713.0	39.5360	14.3642		1713.0	52.1619	15.5462
1714.5	39.0938	14.3103		1714.5	52.2818	15.5855
1716.0	39.3838	14.3304		1716.0	52.4800	15.7060
1717.5	39.5429	14.1334		1717.5	52.6990	15.7772
1719.0	39.1216	14.3645		1719.0	52.3732	15.7068
1720.5	39.2480	14.1715		1720.5	52.2781	15.5875
1722.0	39.1013	14.1078		1722.0	52.2695	15.6008
1723.5	39.1194	14.2859		1723.5	52.2158	15.5342
1725.0	39.6084	14.4287		1725.0	52.4600	15.6465
1726.5	39.6357	14.4848		1726.5	52.3698	15.6190
1728.0	39.5508	14.4319		1728.0	52.1438	15.4919
1729.5	39.2745	14.3814		1729.5	52.2880	15.5379
1731.0	39.3679	14.3756		1731.0	52.1937	15.5266
1732.5	39.2483	14.3847		1732.5	52.5534	15.7503
1734.0	39.3173	14.2296		1734.0	52.5889	15.7358
1735.5	39.3774	14.3617		1735.5	52.1230	15.4825
1737.0	39.3629	14.3312		1737.0	52.0029	15.4192
1738.5	39.6087	14.4921		1738.5	52.3126	15.5597
1740.0	39.5271	14.2710		1740.0	52.5416	15.7159
1741.5	39.3534	14.3905		1741.5	52.3556	15.5669
1743.0	39.3835	14.2791		1743.0	52.1811	15.5034
1744.5	39.1413	14.3601		1744.5	52.5739	15.7673
1746.0	39.3653	14.3261		1746.0	52.6213	15.7694
1747.5	39.3114	14.1544		1747.5	52.2910	15.6522
1749.0	39.1108	14.2569		1749.0	51.9388	15.4463
1750.5	39.1615	14.4780		1750.5	51.9850	15.5049
1752.0	39.2050	14.2755		1752.0	52.5624	15.8026
1753.5	39.2418	14.3233		1753.5	52.6873	15.7853
1755.0	39.4059	14.5312		1755.0	52.4572	15.7096
1756.5	39.2941	14.1897		1756.5	52.3293	15.6401
1758.0	39.4774	14.2510		1758.0	52.5245	15.7111
1759.5	39.3018	14.2599		1759.5	52.6102	15.7639
1761.0	39.4263	14.5617		1761.0	52.3919	15.7252
1762.5	39.6110	14.4692		1762.5	52.4466	15.6620
1764.0	39.3619	14.3816		1764.0	52.7221	15.8530
1765.5	39.5502	14.2794		1765.5	52.6741	15.7972
1767.0	39.3111	14.2606		1767.0	52.5483	15.7545
1768.5	39.5169	14.3197		1768.5	52.3531	15.7437
1770.0	39.5032	14.3322		1770.0	52.5950	15.7495
1771.5	39.3994	14.1560		1771.5	52.6456	15.7515
1773.0	39.3712	14.1551		1773.0	52.3546	15.6818
1774.5	39.1877	14.0876		1774.5	52.3208	15.6430
1776.0	39.5882	14.2022		1776.0	52.6550	15.7872
1777.5	39.5677	14.4112		1777.5	52.7254	15.8787
1779.0	39.2928	14.1714		1779.0	52.6610	15.7959
1780.5	39.2974	14.1381		1780.5	52.4856	15.7328
1782.0	39.5902	14.3679		1782.0	52.6089	15.8156
1783.5	39.4268	14.4072		1783.5	52.7747	15.9088
1785.0	39.2181	14.3332		1785.0	52.8093	15.8736

1900 MHz Head				1900 MHz Body		
Frequency (MHz)	e'	e''		Frequency (MHz)	e'	e''
1850.0	39.5908	13.3391		1850.0	51.9958	14.5484
1851.2	39.6348	13.3115		1851.2	52.0138	14.4493
1852.4	39.7431	13.2434		1852.4	52.0391	14.4510
1853.6	39.7141	13.3224		1853.6	51.9177	14.5141
1854.8	39.5836	13.2678		1854.8	52.0200	14.4633
1856.0	39.5523	13.4137		1856.0	51.8664	14.5331
1857.2	39.6123	13.2420		1857.2	51.9191	14.4456
1858.4	39.5439	13.2534		1858.4	51.9047	14.4290
1859.6	39.6758	13.4315		1859.6	51.9859	14.5188
1860.8	39.6028	13.4019		1860.8	52.0978	14.4640
1862.0	39.6846	13.4141		1862.0	51.8079	14.4609
1863.2	39.7195	13.2845		1863.2	52.0052	14.5567
1864.4	39.5935	13.2787		1864.4	51.9749	14.5047
1865.6	39.5602	13.3142		1865.6	51.8394	14.4564
1866.8	39.6002	13.3477		1866.8	52.0238	14.5780
1868.0	39.6359	13.4130		1868.0	51.8906	14.4409
1869.2	39.7108	13.2929		1869.2	51.9375	14.5211
1870.4	39.5551	13.4287		1870.4	51.8370	14.5230
1871.6	39.6580	13.3664		1871.6	52.0486	14.5092
1872.8	39.6519	13.3916		1872.8	52.0039	14.4170
1874.0	39.5780	13.4001		1874.0	51.8475	14.4390
1875.2	39.6962	13.2717		1875.2	51.9573	14.4290
1876.4	39.7024	13.4281		1876.4	51.8931	14.4935
1877.6	39.6869	13.2663		1877.6	52.0863	14.5121
1878.8	39.6977	13.3574		1878.8	52.0204	14.4297
1880.0	39.6992	13.3181		1880.0	51.8819	14.5028
1881.2	39.6493	13.2818		1881.2	52.0066	14.5599
1882.4	39.6118	13.4153		1882.4	51.8670	14.4949
1883.6	39.7218	13.3503		1883.6	51.9109	14.4607
1884.8	39.6264	13.2684		1884.8	51.9860	14.4152
1886.0	39.6179	13.4072		1886.0	51.7690	14.5311
1887.2	39.6773	13.4161		1887.2	51.8761	14.4813
1888.4	39.7123	13.2805		1888.4	51.7764	14.5182
1889.6	39.5819	13.3662		1889.6	51.7853	14.4839
1890.8	39.6659	13.3364		1890.8	51.8918	14.5251
1892.0	39.6020	13.3876		1892.0	51.9986	14.5233
1893.2	39.7155	13.4193		1893.2	51.9993	14.5781
1894.4	39.6547	13.3742		1894.4	51.9230	14.5343
1895.6	39.6508	13.4041		1895.6	51.8845	14.5128
1896.8	39.6483	13.2505		1896.8	51.7408	14.4856
1898.0	39.6184	13.2797		1898.0	51.7795	14.4487
1899.2	39.6647	13.3620		1899.2	51.9770	14.4747
1900.4	39.5605	13.2830		1900.4	51.8418	14.4448
1901.6	39.6358	13.3496		1901.6	51.9886	14.4721
1902.8	39.6024	13.4282		1902.8	51.9643	14.5199
1904.0	39.6498	13.3375		1904.0	52.0336	14.4429
1905.2	39.7258	13.2556		1905.2	51.8869	14.5239
1906.4	39.6966	13.2650		1906.4	51.7554	14.5209
1907.6	39.7313	13.4216		1907.6	51.9541	14.4734
1908.8	39.5502	13.2423		1908.8	51.8869	14.4345
1910.0	39.6840	13.3611		1910.0	51.8456	14.5579

System Accuracy Verification

Prior to the assessment, the system validation kit was used to test whether the system was operating within its specifications of $\pm 10\%$. The validation results are tabulated below. And also the corresponding SAR plot is attached as well in the SAR plots files.

System Verification Setup Block Diagram

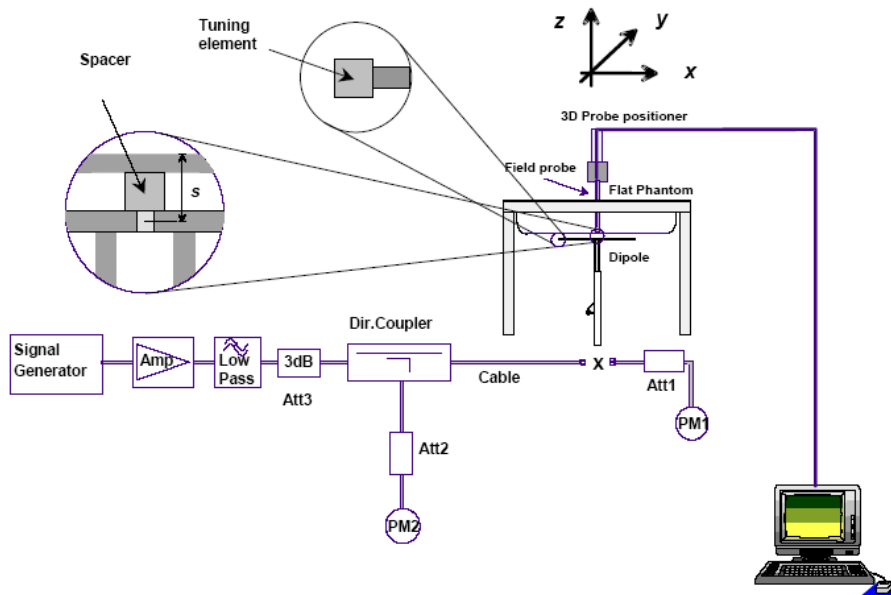

Probe and dipole antenna List and Detail

Manufacturer	Description	Model	Serial Number	Calibration Date	Calibration Due Date
APREL	Probe	ALS-E-020	500-00283	2014-10-14	2015-10-14
APREL	Dipole antenna(835MHz)	ALS-D-835-S-2	180-00558	2014-10-08	2017-10-08
APREL	Dipole antenna(1750MHz)	ALS-D-1750-S-2	198-00304	2013-10-08	2016-10-08
APREL	Dipole antenna(1900MHz)	ALS-D-1900-S-2	210-00710	2014-10-09	2017-10-09

System Accuracy Check Results:

Date	Frequency Band	Liquid Type	Measured SAR (W/Kg)		Target Value (W/Kg)	Delta (%)	Tolerance (%)
2015-10-06	835	Head	1g	9.736	9.773	-0.379	± 10
		Body	1g	9.850	9.736	1.171	± 10
	1750	Head	1g	37.428	36.650	2.123	± 10
		Body	1g	38.206	39.481	-3.229	± 10
	1900	Head	1g	39.430	39.481	-0.129	± 10
		Body	1g	40.976	39.715	3.175	± 10

*All SAR values are normalized to 1 Watt forward power.

SAR SYSTEM VALIDATION DATA**Test Laboratory: Bay Area Compliance Lab Corp. (Shenzhen)****System Performance Check 835 MHz Head Liquid****Dipole 835 MHz; Type: ALS-D-835-S-2; S/N: 180-00558**

Product Data

Device Name : Dipole 835 MHz
Serial No. : 180-00558
Type : Dipole
Model : ALS-D-835-S-2
Frequency Band : 835
Max. Transmit Pwr : 1 W
Drift Time : 3 min(s)
Power Drift-Start : 9.823 W/kg
Power Drift-Finish : 9.536 W/kg
Power Drift (%) : -3.839

Phantom Data

Name : APREL-Uni
Type : Uni-Phantom
Serial No. : System Default
Location : Center
Description : Default
Phantom Data

Tissue Data

Type : Head
Serial No. : 270-01002
Frequency : 835.0 MHz
Last Calib. Date : 06-Oct-2015
Temperature : 20.00 °C
Ambient Temp. : 21.00 °C
Humidity : 56.00 RH%
Epsilon : 41.03 F/m
Sigma : 0.91 S/m
Density : 1000.00 kg/cu. m

Probe Data

Name : E-Field
Model : E-020
Type : E-Field Triangle
Serial No. : 500-00283
Last Calib. Date : 14-Oct-2014
Frequency Band : 835
Duty Cycle Factor : 1
Conversion Factor : 5.9
Probe Sensitivity : 1.20 1.20 1.20 $\mu\text{V}/(\text{V}/\text{m})^2$
Compression Point : 95.00 mV
Offset : 1.56 mm

Measurement Data

Crest Factor : 1
Scan Type : Complete
Tissue Temp. : 21.00 °C
Ambient Temp. : 21.00 °C
Area Scan : 7x9x1 : Measurement x=10mm, y=10mm, z=4mm
Zoom Scan : 7x7x7 : Measurement x=5mm, y=5mm, z=5mm

1 gram SAR value : 9.736 W/kg
10 gram SAR value : 6.416 W/kg
Area Scan Peak SAR : 9.948 W/kg
Zoom Scan Peak SAR : 15.722 W/kg

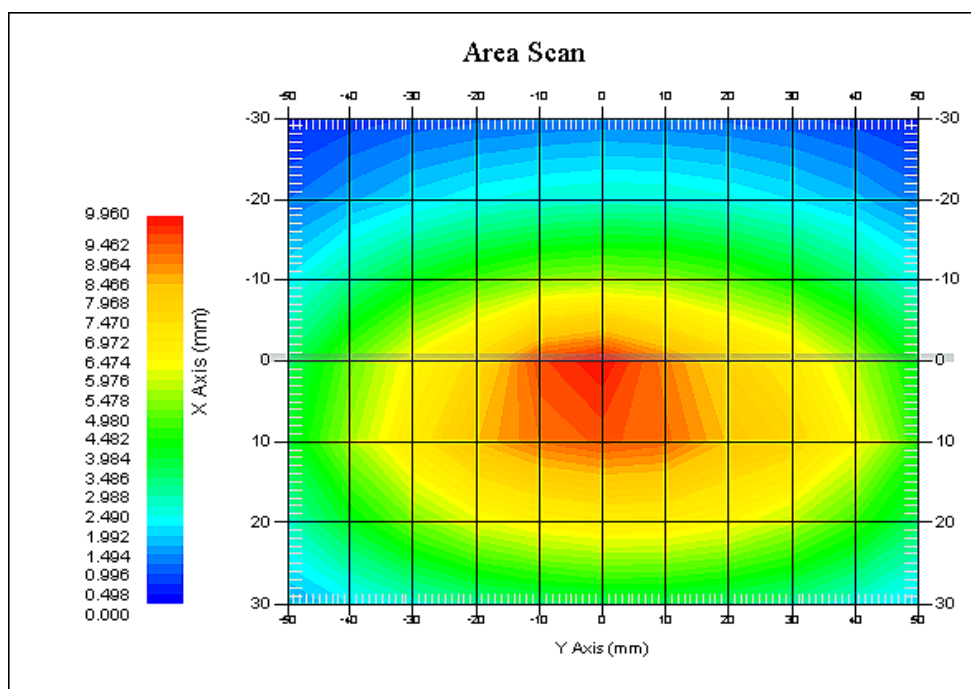

835 MHz System Validation with Head Tissue

Test Laboratory: Bay Area Compliance Lab Corp. (Shenzhen)**System Performance Check 835 MHz Body Liquid****Dipole 835 MHz; Type: ALS-D-835-S-2; S/N: 180-00558**

Product Data

Device Name : Dipole 835 MHz
Serial No. : 180-00558
Type : Dipole
Model : ALS-D-835-S-2
Frequency Band : 835
Max. Transmit Pwr : 1 W
Drift Time : 3 min(s)
Power Drift-Start : 9.315 W/kg
Power Drift-Finish : 9.128 W/kg
Power Drift (%) : -2.037

Phantom Data

Name : APREL-Uni
Type : Uni-Phantom
Serial No. : System Default
Location : Center
Description : Default
Phantom Data

Tissue Data

Type : Body
Serial No. : 270-02101
Frequency : 835.0 MHz
Last Calib. Date : 06-Oct-2015
Temperature : 20.00 °C
Ambient Temp. : 21.00 °C
Humidity : 56.00 RH%
Epsilon : 53.81 F/m
Sigma : 0.96 S/m
Density : 1000.00 kg/cu. m

Probe Data

Name : E-Field
Model : E-020
Type : E-Field Triangle
Serial No. : 500-00283
Last Calib. Date : 14-Oct-2014
Frequency Band : 835
Duty Cycle Factor : 1
Conversion Factor : 5.9
Probe Sensitivity : 1.20 1.20 1.20 $\mu\text{V}/(\text{V}/\text{m})^2$
Compression Point : 95.00 mV
Offset : 1.56 mm

Measurement Data

Crest Factor : 1
Scan Type : Complete
Tissue Temp. : 21.00 °C
Ambient Temp. : 21.00 °C
Area Scan : 7x9x1 : Measurement x=10mm, y=10mm, z=4mm
Zoom Scan : 7x7x7 : Measurement x=5mm, y=5mm, z=5mm

1 gram SAR value : 9.850 W/kg
10 gram SAR value : 6.406 W/kg
Area Scan Peak SAR : 10.929 W/kg
Zoom Scan Peak SAR : 17.208 W/kg

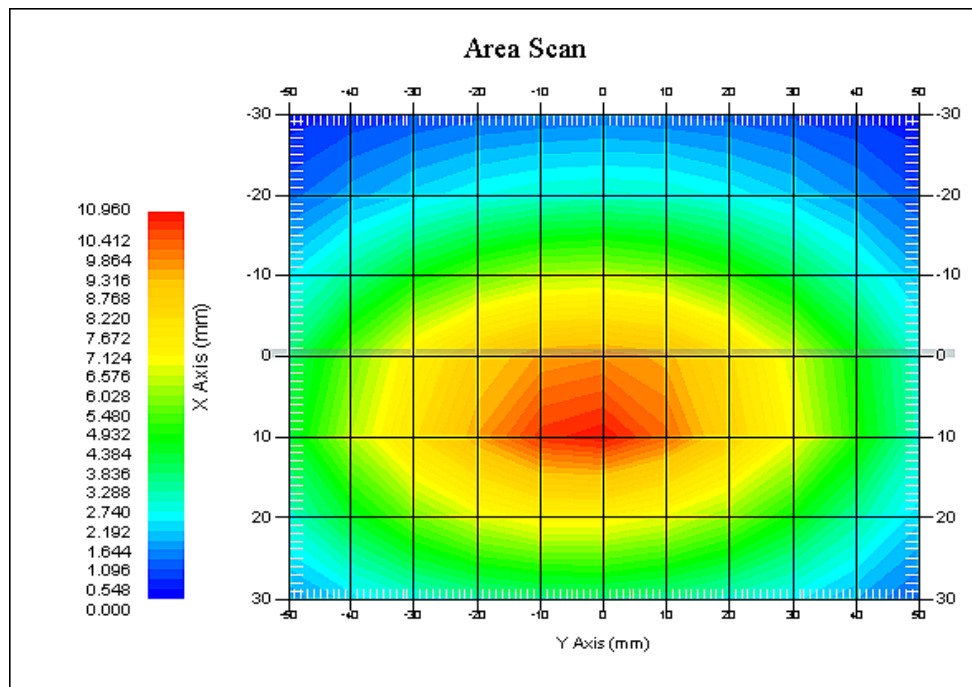

835 MHz System Validation with Body Tissue

Test Laboratory: Bay Area Compliance Lab Corp. (Shenzhen)**System Performance Check 1750 MHz Head Liquid****Dipole 1750 MHz; Type: ALS-D-1750-S-2; S/N: 198-00304**

Product Data

Device Name : Dipole 1750MHz
Serial No. : 198-00304
Type : Dipole
Model : ALS-D-1750-S-2
Frequency Band : 1700
Max. Transmit Pwr : 1 W
Drift Time : 3 min(s)
Power Drift-Start : 36.133 W/kg
Power Drift-Finish : 36.568 W/kg
Power Drift (%) : 1.216

Phantom Data

Name : APREL-Uni
Type : Uni-Phantom
Serial No. : System Default
Location : Center
Description : Default

Tissue Data

Type : Head
Serial No. : 295-01101
Frequency : 1750.00 MHz
Last Calib. Date : 06-Oct-2015
Temperature : 20.00 °C
Ambient Temp. : 21.00 °C
Humidity : 56.00 RH%
Epsilon : 39.13 F/m
Sigma : 1.41 S/m
Density : 1000.00 kg/cu. M

Probe Data

Name : E-Field
Model : E-020
Type : E-Field Triangle
Serial No. : 500-00283
Last Calib. Date : 14-Oct-2014
Frequency Band : 1750
Duty Cycle Factor : 1
Conversion Factor : 5.4
Probe Sensitivity : 1.20 1.20 1.20 $\mu\text{V}/(\text{V}/\text{m})^2$
Compression Point : 95.00 mV
Offset : 1.56 mm

Measurement Data

Crest Factor : 1
Scan Type : Complete
Tissue Temp. : 20.00 °C
Ambient Temp. : 20.00 °C
Area Scan : 7x9x1 : Measurement x=10mm, y=10mm, z=4mm
Zoom Scan : 7x7x7 : Measurement x=5mm, y=5mm, z=5mm

1 gram SAR value : 37.428 W/kg
10 gram SAR value : 18.539 W/kg
Area Scan Peak SAR : 40.920 W/kg
Zoom Scan Peak SAR : 66.233 W/kg

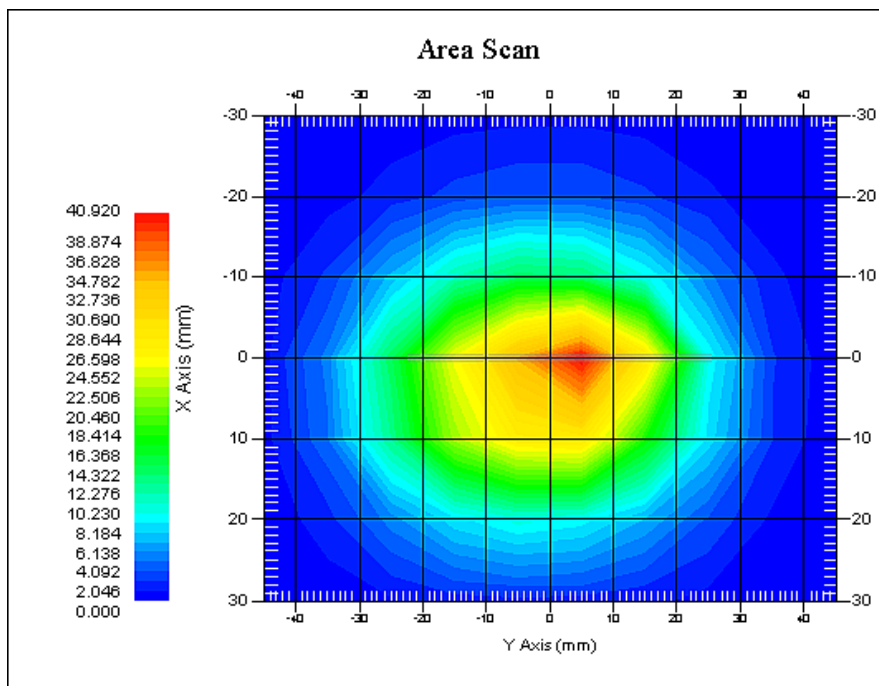

1750 MHz System Validation with Head Tissue

Test Laboratory: Bay Area Compliance Lab Corp. (Shenzhen)**System Performance Check 1750 MHz Body Liquid****Dipole 1750 MHz; Type: ALS-D-1750-S-2; S/N: 198-00304**

Product Data

Device Name : Dipole 1750MHz
Serial No. : 198-00304
Type : Dipole
Model : ALS-D-1750-S-2
Frequency Band : 1700
Max. Transmit Pwr : 1 W
Drift Time : 3 min(s)
Power Drift-Start : 22.620 W/kg
Power Drift-Finish : 22.406 W/kg
Power Drift (%) : -1.063

Phantom Data

Name : APREL-Uni
Type : Uni-Phantom
Serial No. : System Default
Location : Center
Description : Default

Tissue Data

Type : Body
Serial No. : 295-02105
Frequency : 1750.00 MHz
Last Calib. Date : 06-Oct-2015
Temperature : 20.00 °C
Ambient Temp. : 21.00 °C
Humidity : 56.00 RH%
Epsilon : 51.88 F/m
Sigma : 1.52 S/m
Density : 1000.00 kg/cu. m

Probe Data

Name : E-Field
Model : E-020
Type : E-Field Triangle
Serial No. : 500-00283
Last Calib. Date : 14-Oct-2014
Frequency Band : 1750
Duty Cycle Factor : 1
Conversion Factor : 5.3
Probe Sensitivity : 1.20 1.20 1.20 $\mu\text{V}/(\text{V}/\text{m})^2$
Compression Point : 95.00 mV
Offset : 1.56 mm

Measurement Data

Crest Factor : 1
Scan Type : Complete
Tissue Temp. : 20.00 °C
Ambient Temp. : 21.00 °C
Area Scan : 7x9x1 : Measurement x=10mm, y=10mm, z=4mm
Zoom Scan : 7x7x7 : Measurement x=5mm, y=5mm, z=5mm

1 gram SAR value : 38.206 W/kg
 10 gram SAR value : 19.818 W/kg
 Area Scan Peak SAR : 41.760 W/kg
 Zoom Scan Peak SAR : 65.375 W/kg

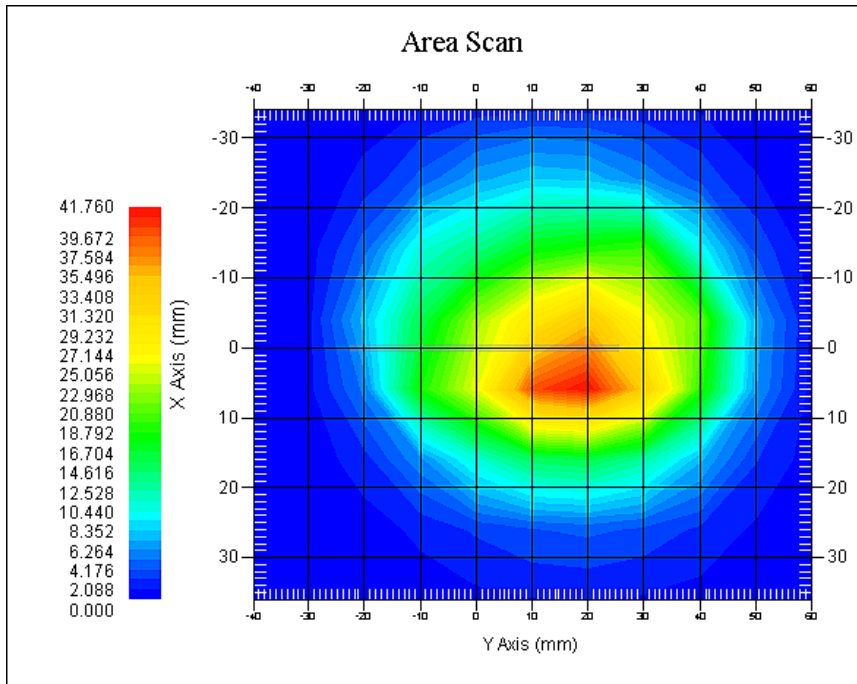

1750 MHz System Validation with Body Tissue

Test Laboratory: Bay Area Compliance Lab Corp. (Shenzhen)**System Performance Check 1900 MHz Head Liquid****Dipole 1900 MHz; Type: ALS-D-1900-S-2; S/N: 210-00710**

Product Data

Device Name : Dipole 1900MHz
Serial No. : 210-00710
Type : Dipole
Model : ALS-D-1900-S-2
Frequency Band : 1900
Max. Transmit Pwr : 1 W
Drift Time : 3 min(s)
Power Drift-Start : 39.226 W/kg
Power Drift-Finish : 39.886 W/kg
Power Drift (%) : 1.509

Phantom Data

Name : APREL-Uni
Type : Uni-Phantom
Serial No. : System Default
Location : Center
Description : Default

Tissue Data

Type : Head
Serial No. : 295-01103
Frequency : 1900.00 MHz
Last Calib. Date : 06-Oct-2015
Temperature : 20.00 °C
Ambient Temp. : 21.00 °C
Humidity : 56.00 RH%
Epsilon : 39.56 F/m
Sigma : 1.40 S/m
Density : 1000.00 kg/cu. M

Probe Data

Name : E-Field
Model : E-020
Type : E-Field Triangle
Serial No. : 500-00283
Last Calib. Date : 14-Oct-2014
Frequency Band : 1900
Duty Cycle Factor : 1
Conversion Factor : 4.8
Probe Sensitivity : 1.20 1.20 1.20 $\mu\text{V}/(\text{V}/\text{m})^2$
Compression Point : 95.00 mV
Offset : 1.56 mm

Measurement Data

Crest Factor : 1
Scan Type : Complete
Tissue Temp. : 20.00 °C
Ambient Temp. : 20.00 °C
Area Scan : 7x9x1 : Measurement x=10mm, y=10mm, z=4mm
Zoom Scan : 7x7x7 : Measurement x=5mm, y=5mm, z=5mm

1 gram SAR value : 39.430 W/kg
10 gram SAR value : 20.406 W/kg
Area Scan Peak SAR : 42.308 W/kg
Zoom Scan Peak SAR : 67.272 W/kg

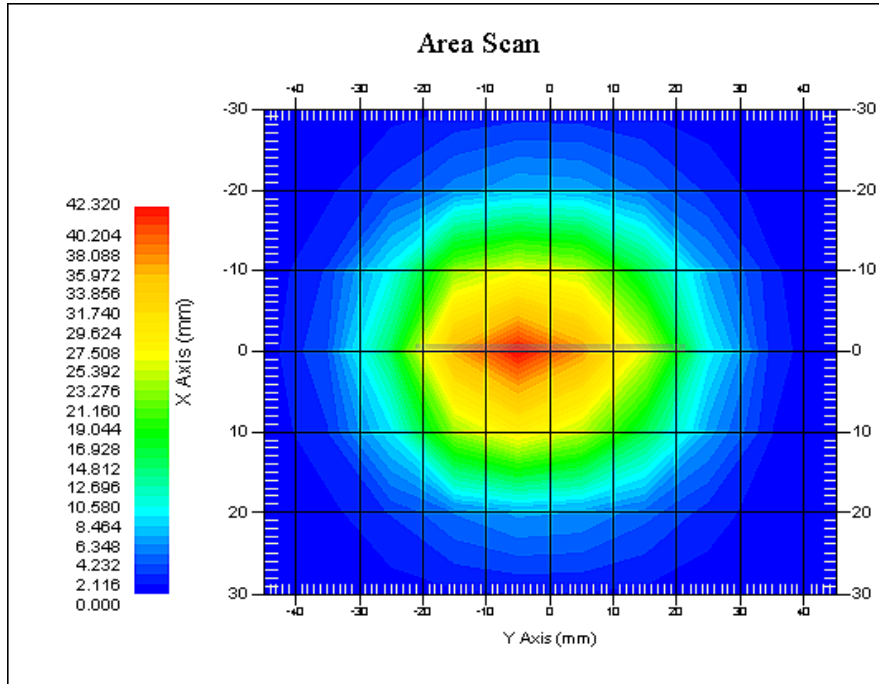

1900 MHz System Validation with Head Tissue

Test Laboratory: Bay Area Compliance Lab Corp. (Shenzhen)**System Performance Check 1900 MHz Body Liquid****Dipole 1900 MHz; Type: ALS-D-1900-S-2; S/N: 210-00710**

Product Data

Device Name : Dipole 1900MHz
Serial No. : 210-00710
Type : Dipole
Model : ALS-D-1900-S-2
Frequency Band : 1900
Max. Transmit Pwr : 1 W
Drift Time : 3 min(s)
Power Drift-Start : 40.403 W/kg
Power Drift-Finish : 40.912 W/kg
Power Drift (%) : 1.263

Phantom Data

Name : APREL-Uni
Type : Uni-Phantom
Serial No. : System Default
Location : Center
Description : Default

Tissue Data

Type : Body
Serial No. : 295-02102
Frequency : 1900.00 MHz
Last Calib. Date : 06-Oct-2015
Temperature : 20.00 °C
Ambient Temp. : 21.00 °C
Humidity : 56.00 RH%
Epsilon : 51.88 F/m
Sigma : 1.53 S/m
Density : 1000.00 kg/cu. m

Probe Data

Name : E-Field
Model : E-020
Type : E-Field Triangle
Serial No. : 500-00283
Last Calib. Date : 14-Oct-2014
Frequency Band : 1900
Duty Cycle Factor : 1
Conversion Factor : 4.5
Probe Sensitivity : 1.20 1.20 1.20 $\mu\text{V}/(\text{V}/\text{m})^2$
Compression Point : 95.00 mV
Offset : 1.56 mm

Measurement Data

Crest Factor : 1
Scan Type : Complete
Tissue Temp. : 20.00 °C
Ambient Temp. : 21.00 °C
Area Scan : 7x9x1 : Measurement x=10mm, y=10mm, z=4mm
Zoom Scan : 7x7x7 : Measurement x=5mm, y=5mm, z=5mm

1 gram SAR value : 40.976 W/kg
10 gram SAR value : 21.353 W/kg
Area Scan Peak SAR : 41.772 W/kg
Zoom Scan Peak SAR : 73.560 W/kg

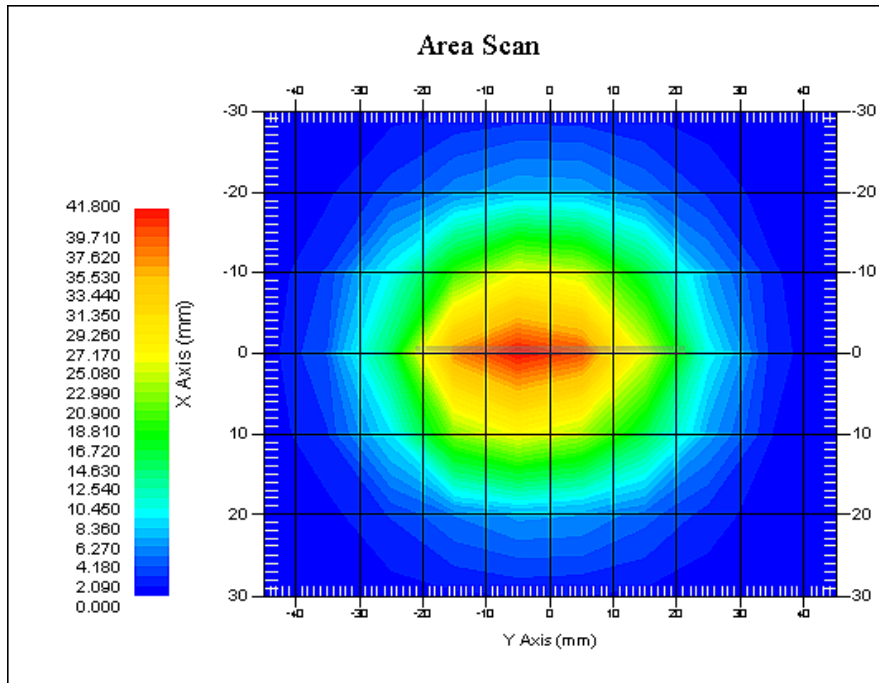

1900 MHz System Validation with Body Tissue

EUT TEST STRATEGY AND METHODOLOGY

Test Positions for Device Operating Next to a Person’s Ear

This category includes most wireless handsets with fixed, retractable or internal antennas located toward the top half of the device, with or without a foldout, sliding or similar keypad cover. The handset should have its earpiece located within the upper ¼ of the device, either along the centerline or off-centered, as perceived by its users. This type of handset should be positioned in a normal operating position with the “test device reference point” located along the “vertical centerline” on the front of the device aligned to the “ear reference point”. The “test device reference point” should be located at the same level as the center of the earpiece region. The “vertical centerline” should bisect the front surface of the handset at its top and bottom edges. A “ear reference point” is located on the outer surface of the head phantom on each ear spacer. It is located 1.5 cm above the center of the ear canal entrance in the “phantom reference plane” defined by the three lines joining the center of each “ear reference point” (left and right) and the tip of the mouth.

A handset should be initially positioned with the earpiece region pressed against the ear spacer of a head phantom. For the SCC-34/SC-2 head phantom, the device should be positioned parallel to the “N-F” line defined along the base of the ear spacer that contains the “ear reference point”. For interim head phantoms, the device should be positioned parallel to the cheek for maximum RF energy coupling. The “test device reference point” is aligned to the “ear reference point” on the head phantom and the “vertical centerline” is aligned to the “phantom reference plane”. This is called the “initial ear position”. While maintaining these three alignments, the body of the handset is gradually adjusted to each of the following positions for evaluating SAR:

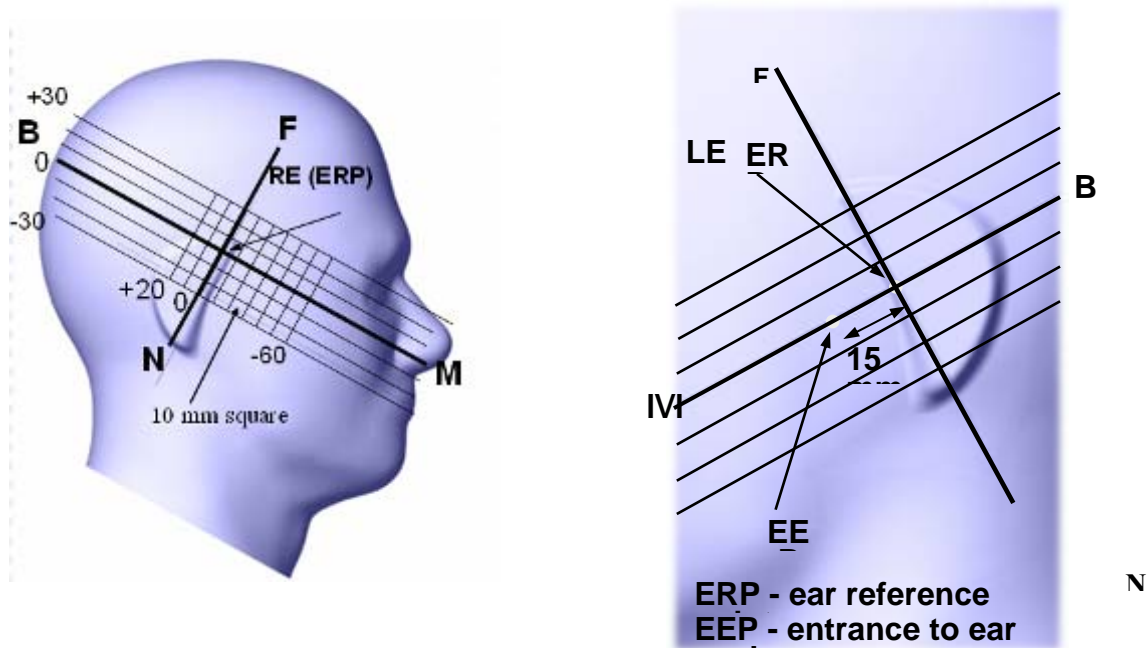

Cheek/Touch Position

The device is brought toward the mouth of the head phantom by pivoting against the “ear reference point” or along the “N-F” line for the SCC-34/SC-2 head phantom.

This test position is established:

- When any point on the display, keypad or mouthpiece portions of the handset is in contact with the phantom.
- (or) When any portion of a foldout, sliding or similar keypad cover opened to its intended self-adjusting normal use position is in contact with the cheek or mouth of the phantom.

For existing head phantoms – when the handset loses contact with the phantom at the pivoting point, rotation should continue until the device touches the cheek of the phantom or breaks its last contact from the ear spacer.

Cheek /Touch Position

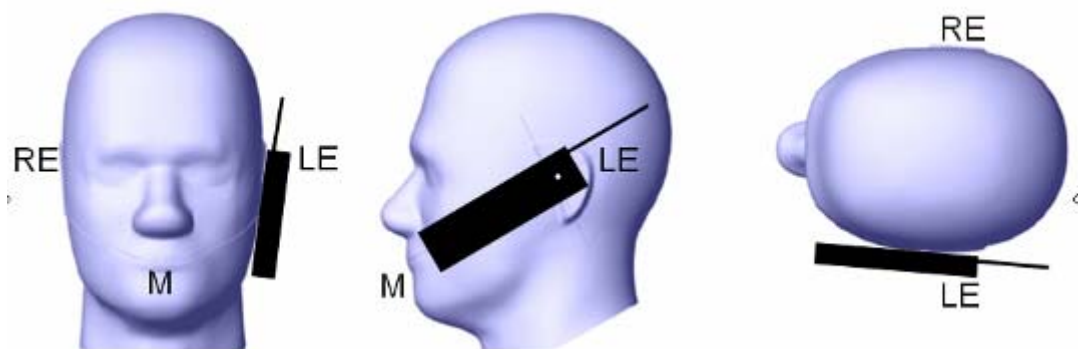

Ear/Tilt Position

With the handset aligned in the “Cheek/Touch Position”:

1) If the earpiece of the handset is not in full contact with the phantom’s ear spacer (in the “Cheek/Touch position”) and the peak SAR location for the “Cheek/Touch” position is located at the ear spacer region or corresponds to the earpiece region of the handset, the device should be returned to the “initial ear position” by rotating it away from the mouth until the earpiece is in full contact with the ear spacer.

2) (otherwise) The handset should be moved (translated) away from the cheek perpendicular to the line passes through both “ear reference points” (note: one of these ear reference points may not physically exist on a split head model) for approximate 2-3 cm. While it is in this position, the device handset is tilted away from the mouth with respect to the “test device reference point” until the inside angle between the vertical centerline on the front surface of the phone and the horizontal line passing through the ear reference point is by 15 80°. After the tilt, it is then moved (translated) back toward the head perpendicular to the line passes through both “ear reference points” until the device touches the phantom or the ear spacer. If the antenna touches the head first, the positioning process should be repeated with a tilt angle less than 15° so that the device and its antenna would touch the phantom simultaneously. This test position may require a device holder or positioner to achieve the translation and tilting with acceptable positioning repeatability.

If a device is also designed to transmit with its keypad cover closed for operating in the head position, such positions should also be considered in the SAR evaluation. The device should be tested on the left and right side of the head phantom in the “Cheek/Touch” and “Ear/Tilt” positions. When applicable, each configuration should be tested with the antenna in its fully extended and fully retracted positions. These test configurations should be tested at the high, middle and low frequency channels of each operating mode; for example, AMPS, CDMA, and TDMA. If the SAR measured at the middle channel for each test configuration (left, right, Cheek/Touch, Tilt/Ear, extended and retracted) is at least 2.0 dB lower than the SAR limit, testing at the high and low channels is optional for such test configuration(s). If the transmission band of the test device is less than 10 MHz, testing at the high and low frequency channels is optional.

Ear /Tilt 15° Position

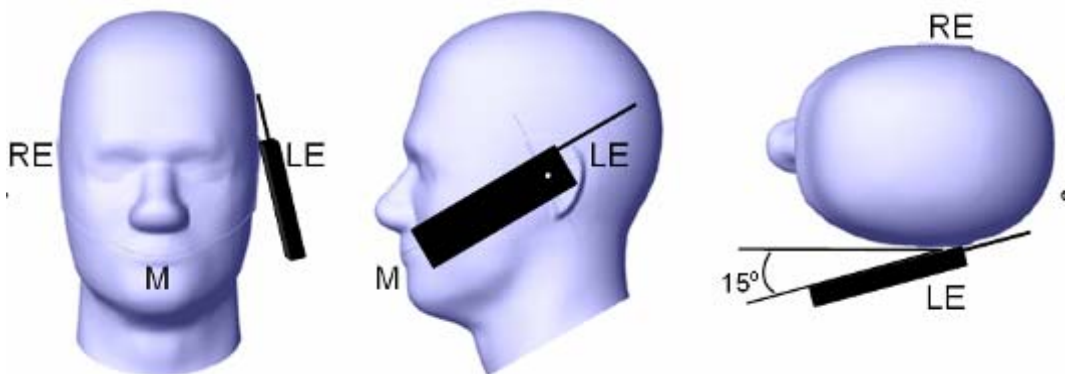

Test positions for body-worn and other configurations

Body-worn operating configurations should be tested with the belt-clips and holsters attached to the device and positioned against a flat phantom in normal use configurations. Devices with a headset output should be tested with a headset connected to the device. When multiple accessories that do not contain metallic components are supplied with the device, the device may be tested with only the accessory that dictates the closest spacing to the body. When multiple accessories that contain metallic components are supplied with the device, the device must be tested with each accessory that contains a unique metallic component. If multiple accessories share an identical metallic component (e.g., the same metallic belt-clip used with different holsters with no other metallic components), only the accessory that dictates the closest spacing to the body must be tested.

Body-worn accessories may not always be supplied or available as options for some devices that are intended to be authorized for body-worn use. A separation distance of 1.5 cm between the back of the device and a flat phantom is recommended for testing body-worn SAR compliance under such circumstances. Other separation distances may be used, but they should not exceed 2.5 cm. In these cases, the device may use body-worn accessories that provide a separation distance greater than that tested for the device provided however that the accessory contains no metallic components.

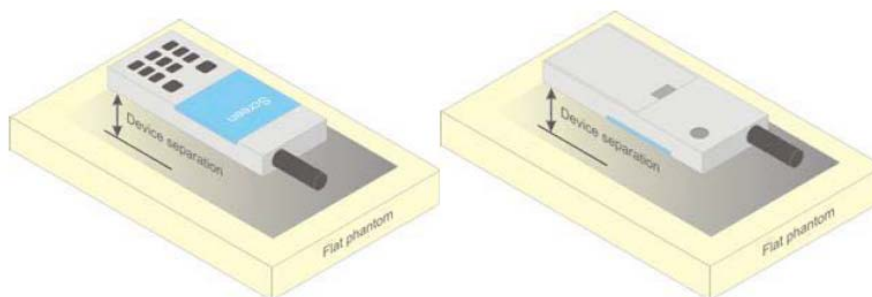

Figure 5 – Test positions for body-worn devices

SAR Evaluation Procedure

The evaluation was performed with the following procedure:

Step 1: Measurement of the SAR value at a fixed location above the ear point or central position was used as a reference value for assessing the power drop. The SAR at this point is measured at the start of the test and then again at the end of the testing.

Step 2: The SAR distribution at the exposed side of the head was measured at a distance of 4 mm from the inner surface of the shell. The area covered the entire dimension of the head or EUT and the horizontal grid spacing was 10 mm x 10 mm. Based on these data, the area of the maximum absorption was determined by spline interpolation. The first Area Scan covers the entire dimension of the EUT to ensure that the hotspot was correctly identified.

Step 3: Around this point, a volume of 35 mm x 35 mm x 35 mm was assessed by measuring 7x 7 x 7 points. On the basis of this data set, the spatial peak SAR value was evaluated under the following procedure:

- 1) The data at the surface were extrapolated, since the center of the dipoles is 1.2 mm away from the tip of the probe and the distance between the surface and the lowest measuring point is 1.3 mm. The extrapolation was based on a least square algorithm. A polynomial of the fourth order was calculated through the points in z-axes. This polynomial was then used to evaluate the points between the surface and the probe tip.
- 2) The maximum interpolated value was searched with a straightforward algorithm. Around this maximum the SAR values averaged over the spatial volumes (1 g or 10 g) were computed by the 3D-Spline interpolation algorithm. The 3D-Spline is composed of three one dimensional splines with the "Not a knot"-condition (in x, y and z-directions). The volume was integrated with the trapezoidal-algorithm. One thousand points (10 x 10 x 10) were interpolated to calculate the averages.

All neighboring volumes were evaluated until no neighboring volume with a higher average value was found.

Step 4: Re-measurement of the SAR value at the same location as in Step 1. If the value changed by more than 5%, the evaluation was repeated.

Test methodology

KDB 447498 D01 General RF Exposure Guidance v05r02.
KDB 648474 D04 Handset SAR v01r02.
KDB 865664 D01 SAR measurement 100 MHz to 6 GHz v01r03
KDB 865664 D02 RF Exposure Reporting v01r01
KDB 941225 D01 3G SAR Procedures v03
KDB 941225 D05 SAR for LTE Devices v02r03
KDB 941225 D06 Hotspot Mode v02

CONDUCTED OUTPUT POWER MEASUREMENT

Provision Applicable

The measured peak output power should be greater and within 5% than EMI measurement.

Test Procedure

The RF output of the transmitter was connected to the input of the EMI Test Receiver through sufficient attenuation.

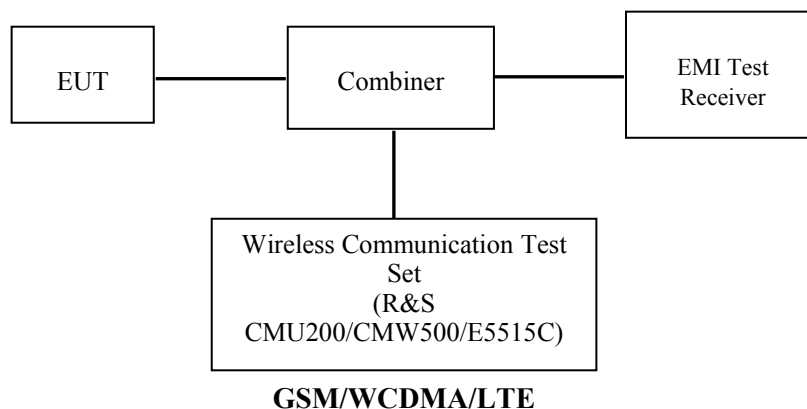

Radio Configuration

The power measurement was configured by the Wireless Communication Test Set CMU200 & CMW500 for all Radio configurations except the HSPA+/DC-HSDPA configured by E5515C..

GSM

Function: Menu select > GSM Mobile Station > GSM 850/1900

Press Connection control to choose the different menus

Press RESET > choose all the reset all settings

Connection: Press Signal Off to turn off the signal and change settings

Network Support > GSM + only

MS Signal

> 33 dBm for GSM 850

> 30 dBm for PCS 1900

BS Signal: Enter the same channel number for TCH channel (test channel) and BCCH channel

Frequency Offset >+ 0 Hz

Mode > BCCH and TCH

BCCH Level > -85 dBm (May need to adjust if link is not stable)

BCCH Channel > choose desired test channel [Enter the same channel number for TCH channel (test channel) and BCCH channel]

Channel Type > Off

P0 > 4 dB

TCH > choose desired test channel

Hopping > Off

AF/RF: Enter appropriate offsets for Ext. Att. Output and Ext. Att. Input

Connection: Press Signal on to turn on the signal and change settings

GPRS

Function: Menu select > GSM Mobile Station > GSM 850/1900
 Press Connection control to choose the different menus
 Press RESET > choose all the reset all settings
 Connection: Press Signal Off to turn off the signal and change settings
 Network Support > GSM + GPRS or GSM + EGSM
 Main Service > Packet Data

Service selection > Test Mode A – Auto Slot Config. off
 MS Signal: Press Slot Config Bottom on the right twice to select and change the number of time slots and power setting
 > Slot configuration > Uplink/Gamma
 > 33 dBm for GPRS 850
 > 30 dBm for GPRS 1900

BS Signal: Enter the same channel number for TCH channel (test channel) and BCCH channel
 Frequency Offset >+ 0 Hz
 Mode >BCCH and TCH
 BCCH Level >-85 dBm (May need to adjust if link is not stable)
 BCCH Channel > choose desire test channel [Enter the same channel number for TCH channel (test channel) and BCCH channel]

Channel Type > Off
 P0 > 4 dB
 Slot Config > Unchanged (if already set under MS signal)
 TCH > choose desired test channel
 Hopping >Off
 Main Timeslot >3
 Network: Coding Scheme >CS4 (GPRS)
 Bit Stream >2E9-1 PSR Bit Stream
 AF/RF: Enter appropriate offsets for Ext. Att. Output and Ext. Att. Input
 Connection: Press Signal on to turn on the signal and change settings

WCDMA Release 99

The following tests were conducted according to the test requirements outlines in section 5.2 of the 3GPP TS34.121-1 specification. The EUT has a nominal maximum output power of 24dBm (+1.7/-3.7).

WCDMA General Settings	Loopback Mode	Test Mode 1
	Rel99 RMC	12.2kbps RMC
	Power Control Algorithm	Algorithm2
	$\beta c / \beta d$	8/15

HSDPA

The following tests were conducted according to the test requirements outlines in section 5.2 of the 3GPP TS34.121-1 specification.

	Mode Subset	HSDPA 1	HSDPA 2	HSDPA 3	HSDPA 4
WCDMA General Settings	Loopback Mode	Test Mode 1			
	Rel99 RMC	12.2kbps RMC			
	HSDPA FRC	H-Set1			
	Power Control Algorithm	Algorithm2			
	βc	2/15	12/15	15/15	15/15
	βd	15/15	15/15	8/15	4/15
	βd (SF)	64			
	$\beta c / \beta d$	2/15	12/15	15/8	15/4
	βhs	4/15	24/15	30/15	30/15
MPR(dB)	0	0	0.5	0.5	
HSDPA Specific Settings	DACK	8			
	DNAK	8			
	DCQI	8			
	Ack-Nack repetition factor	3			
	CQI Feedback	4ms			
	CQI Repetition Factor	2			
	$Ahs = \beta hs / \beta c$	30/15			

HSUPA

The following tests were conducted according to the test requirements outlines in section 5.2 of the 3GPP TS34.121-1 specification.

	Mode	HSUPA	HSUPA	HSUPA	HSUPA	HSUPA
	Subset	1	2	3	4	5
WCDM A General Settings	Loopback Mode	Test Mode 1				
	Rel99 RMC	12.2kbps RMC				
	HSDPA FRC	H-Set1				
	HSUPA Test	HSUPA Loopback				
	Power Control Algorithm	Algorithm2				
	βc	11/15	6/15	15/15	2/15	15/15
	βd	15/15	15/15	9/15	15/15	0
	βec	209/225	12/15	30/15	2/15	5/15
	$\beta c/ \beta d$	11/15	6/15	15/9	2/15	-
	βhs	22/15	12/15	30/15	4/15	5/15
	CM(dB)	1.0	3.0	2.0	3.0	1.0
MPR(dB)	0	2	1	2	0	
HSDPA Specific Settings	DACK	8				
	DNAK	8				
	DCQI	8				
	Ack-Nack repetition factor	3				
	CQI Feedback	4ms				
	CQI Repetition Factor	2				
	$A_{hs} = \beta_{hs} / \beta c$	30/15				
HSUPA Specific Settings	DE-DPCCH	6	8	8	5	7
	DHARQ	0	0	0	0	0
	AG Index	20	12	15	17	21
	ETFCI	75	67	92	71	81
	Associated Max UL Data Rate kbps	242.1	174.9	482.8	205.8	308.9
	Reference E_FCI	E-TFCI 11 E E-TFCI PO 4 E-TFCI 67 E-TFCI PO 18 E-TFCI 71 E-TFCI PO23 E-TFCI 75 E-TFCI PO26 E-TFCI 81 E-TFCI PO 27	E-TFCI 11 E-TFCI PO4 E-TFCI 92 E-TFCI PO 18	E-TFCI 11 E E-TFCI PO 4 E-TFCI 67 E-TFCI PO 18 E-TFCI 71 E-TFCI PO23 E-TFCI 75 E-TFCI PO26 E-TFCI 81 E-TFCI PO 27		

HSPA+

The following tests were conducted according to the test requirements in Table C.11.1.4 of 3GPP TS 34.121-1

Sub-test	β_c (Note3)	β_d	β_{HS} (Note1)	β_{ec}	β_{ed} (2xSF2) (Note 4)	β_{ed} (2xSF4) (Note 4)	CM (dB) (Note 2)	MPR (dB) (Note 2)	AG Index (Note 4)	E-TFCI (Note 5)	E-TFCI (boost)
1	1	0	30/15	30/15	β_{ed1} : 30/15 β_{ed2} : 30/15	β_{ed3} : 24/15 β_{ed4} : 24/15	3.5	2.5	14	105	105

- Note 1: $\Delta_{ACK}, \Delta_{NACK}$ and $\Delta_{CQI} = 30/15$ with $\beta_{hs} = 30/15 * \beta_c$.
- Note 2: CM = 3.5 and the MPR is based on the relative CM difference, MPR = MAX(CM-1,0).
- Note 3: DPDCH is not configured, therefore the β_c is set to 1 and $\beta_d = 0$ by default.
- Note 4: β_{ed} can not be set directly; it is set by Absolute Grant Value.
- Note 5: All the sub-tests require the UE to transmit 2SF2+2SF4 16QAM EDCH and they apply for UE using E-DPDCH category 7. E-DCH TTI is set to 2ms TTI and E-DCH table index = 2. To support these E-DCH configurations DPDCH is not allocated. The UE is signalled to use the extrapolation algorithm.

DC-HSDPA

The following tests were conducted according to the test requirements in Table Table C.8.1.12 of 3GPP TS 34.121-1

Table C.8.1.12: Fixed Reference Channel H-Set 12

Parameter	Unit	Value
Nominal Avg. Inf. Bit Rate	kbps	60
Inter-TTI Distance	TTI's	1
Number of HARQ Processes	Processes	6
Information Bit Payload (N_{INF})	Bits	120
Number Code Blocks	Blocks	1
Binary Channel Bits Per TTI	Bits	960
Total Available SML's in UE	SML's	19200
Number of SML's per HARQ Proc.	SML's	3200
Coding Rate		0.15
Number of Physical Channel Codes	Codes	1
Modulation		QPSK
<p>Note 1: The RMC is intended to be used for DC-HSDPA mode and both cells shall transmit with identical parameters as listed in the table.</p> <p>Note 2: Maximum number of transmission is limited to 1, i.e., retransmission is not allowed. The redundancy and constellation version 0 shall be used.</p>		

LTE

For UE Power Class 1 and 3, the allowed Maximum Power Reduction (MPR) for the maximum output power in Table 6.2.2-1 due to higher order modulation and transmit bandwidth configuration (resource blocks) is specified in Table 6.2.3-1.

Table 6.2.3-1: Maximum Power Reduction (MPR) for Power Class 1 and 3

Modulation	Channel bandwidth / Transmission bandwidth (N_{RB})						MPR (dB)
	1.4 MHz	3.0 MHz	5 MHz	10 MHz	15 MHz	20 MHz	
QPSK	> 5	> 4	> 8	> 12	> 16	> 18	≤ 1
16 QAM	≤ 5	≤ 4	≤ 8	≤ 12	≤ 16	≤ 18	≤ 1
16 QAM	> 5	> 4	> 8	> 12	> 16	> 18	≤ 2

For UE Power Class 1 and 3 the specific requirements and identified subclauses are specified in Table 6.2.4-1 along with the allowed A-MPR values that may be used to meet these requirements. The allowed A-MPR values specified below in Table 6.2.4.-1 to 6.2.4-15 are in addition to the allowed MPR requirements specified in subclause 6.2.3.

Table 6.2.4-1: Additional Maximum Power Reduction (A-MPR)

Network Signalling value	Requirements (subclause)	E-UTRA Band	Channel bandwidth (MHz)	Resources Blocks (N_{RB})	A-MPR (dB)
NS_01	6.6.2.1.1	Table 5.5-1	1.4, 3, 5, 10, 15, 20	Table 5.6-1	N/A
NS_03	6.6.2.2.1	2, 4, 10, 23, 25, 35, 36	3	>5	≤ 1
			5	>6	≤ 1
			10	>6	≤ 1
			15	>8	≤ 1
			20	>10	≤ 1
NS_04	6.6.2.2.2	41	5	>6	≤ 1
			10, 15, 20	Table 6.2.4-4	
NS_05	6.6.3.3.1	1	10, 15, 20	≥ 50	≤ 1
NS_06	6.6.2.2.3	12, 13, 14, 17	1.4, 3, 5, 10	Table 5.6-1	N/A
NS_07	6.6.2.2.3 6.6.3.3.2	13	10	Table 6.2.4-2	
NS_08	6.6.3.3.3	19	10, 15	> 44	≤ 3
NS_09	6.6.3.3.4	21	10, 15	> 40	≤ 1
				> 55	≤ 2
				Table 6.2.4-3	
NS_11	6.6.2.2.1	23	1.4, 3, 5, 10, 15, 20	Table 6.2.4-5	
NS_12	6.6.3.3.5	26	1.4, 3, 5	Table 6.2.4-6	
NS_13	6.6.3.3.6	26	5	Table 6.2.4-7	
NS_14	6.6.3.3.7	26	10, 15	Table 6.2.4-8	
NS_15	6.6.3.3.8	26	1.4, 3, 5, 10, 15	Table 6.2.4-9 Table 6.2.4-10	
NS_16	6.6.3.3.9	27	3, 5, 10	Table 6.2.4-11, Table 6.2.4-12, Table 6.2.4-13	
NS_17	6.6.3.3.10	28	5, 10	Table 5.6-1	N/A
NS_18	6.6.3.3.11	28	5	≥ 2	≤ 1
			10, 15, 20	≥ 1	≤ 4
NS_19	6.6.3.3.12	44	10, 15, 20	Table 6.2.4-14	
NS_20	6.2.2	23	5, 10, 15, 20	Table 6.2.4-15	
	6.6.2.2.1				
	6.6.3.2				
...					
NS_32	-	-	-	-	-

Maximum Output Power among production units

Max Target Power for Production Unit (dBm)				
Mode/Band	Channel			
	Low	Middle	High	
GSM 850	32.80	32.80	32.80	
GPRS 1 TX Slot	32.70	32.70	32.70	
GPRS 2 TX Slot	32.20	32.20	32.20	
GPRS 3 TX Slot	30.40	30.40	30.40	
GPRS 4 TX Slot	29.40	29.40	29.40	
EDGE 1 TX Slot	27.00	27.00	27.00	
EDGE 2 TX Slot	25.30	25.30	25.30	
EDGE 3 TX Slot	23.00	23.00	23.00	
EDGE 4 TX Slot	22.10	22.10	22.10	
PCS 1900	28.50	28.50	28.50	
GPRS 1 TX Slot	28.40	28.40	28.40	
GPRS 2 TX Slot	27.80	27.80	27.80	
GPRS 3 TX Slot	25.80	25.80	25.80	
GPRS 4 TX Slot	24.80	24.80	24.80	
EDGE 1 TX Slot	25.60	25.60	25.60	
EDGE 2 TX Slot	24.20	24.20	24.20	
EDGE 3 TX Slot	22.40	22.40	22.40	
EDGE 4 TX Slot	21.10	21.10	21.10	
WCDMA 850	RMC	22.80	22.80	22.80
	HSDPA	22.10	22.10	22.10
	HSUPA	21.90	21.90	21.90
	DC-HSDPA	21.40	21.40	21.40
	HSPA+	21.50	21.50	21.50
WCDMA 1900	RMC	22.90	22.90	22.90
	HSDPA	22.30	22.30	22.30
	HSUPA	22.40	22.40	22.40
	DC-HSDPA	21.80	21.80	21.80
	HSPA+	21.80	21.80	21.80
LTE Band 2	22.70	22.70	22.70	
LTE Band 4	22.60	22.60	22.60	
Wi-Fi(b/g/n20)	9.20	9.20	9.20	
Wi-Fi(n40)	9.20	9.20	9.20	
Bluetooth(GFSK)	-1.00	4.60	-3.00	
Bluetooth(4-DQPSK)	3.50	2.00	-2.00	
Bluetooth(8DPSK)	3.50	-3.50	2.50	
BLE	-8.00	-9.00	-5.50	

Test Results:

GSM:

Band	Channel No.	Frequency (MHz)	Conducted Output Power	
			Meas. Power (dBm)	Meas. Power (W)
GSM 850	128	824.2	32.78	1.897
	190	836.6	32.73	1.875
	251	848.8	32.44	1.754
PCS 1900	512	1850.2	28.49	0.706
	661	1880.0	28.33	0.681
	810	1909.8	28.39	0.690

GPRS:

Band	Channel No.	Frequency (MHz)	RF Output Power (dBm)			
			1 slot	2 slot	3 slots	4 slots
GSM 850	128	824.2	32.63	32.13	30.37	29.22
	190	836.6	32.52	32.05	30.37	29.33
	251	848.8	32.47	31.99	30.28	29.18
PCS 1900	512	1850.2	28.32	27.49	25.73	24.59
	661	1880.0	28.27	27.53	25.76	24.64
	810	1909.8	28.35	27.73	25.79	24.77

EGPRS:

Band	Channel No.	Frequency (MHz)	RF Output Power (dBm)			
			1 slot	2 slot	3 slots	4 slots
GSM 850	128	824.2	26.88	24.82	22.98	22.00
	190	836.6	26.99	25.13	22.89	21.75
	251	848.8	26.81	25.24	22.77	21.85
PCS 1900	512	1850.2	25.54	23.81	21.81	20.93
	661	1880.0	25.43	24.14	22.34	20.70
	810	1909.8	25.27	23.86	22.08	21.09

For SAR, the time based average power is relevant, the difference in between depends on the duty cycle of the TDMA signal.

Number of Time slot	1	2	3	4
Duty Cycle	1:8	1:4	1:2.66	1:2
Time based Ave. power compared to slotted Ave. power	-9 dB	-6 dB	-4.25 dB	-3 dB
Crest Factor	8	4	2.66	2

The time based average power for GPRS

Band	Channel No.	Frequency (MHz)	Time based average Power (dBm)			
			1 slot	2 slot	3 slots	4 slots
GSM 850	128	824.2	23.63	26.13	26.12	26.22
	190	836.6	23.52	26.05	26.12	26.33
	251	848.8	23.47	25.99	26.03	26.18
PCS 1900	512	1850.2	19.32	21.49	21.48	21.59
	661	1880.0	19.27	21.53	21.51	21.64
	810	1909.8	19.35	21.73	21.54	21.77

The time based average power for EGPRS

Band	Channel No.	Frequency (MHz)	Time based average Power (dBm)			
			1 slot	2 slot	3 slots	4 slots
GSM 850	128	824.2	17.88	18.82	18.73	19.00
	190	836.6	17.99	19.13	18.64	18.75
	251	848.8	17.81	19.24	18.52	18.85
PCS 1900	512	1850.2	16.54	17.81	17.56	17.93
	661	1880.0	16.43	18.14	18.09	17.70
	810	1909.8	16.27	17.86	17.83	18.09

Note:

1. Rohde & Schwarz Radio Communication Tester (CMU200) was used for the measurement of GSM peak and average output power for active timeslots.
2. For GSM voice, 1 timeslot has been activated with power level 5 (850 MHz band) and 0 (1900 MHz band).
3. For GPRS, 1, 2, 3 and 4 timeslots has been activated separately with power level 3(850 MHz band) and 3(1900 MHz band).
4. For EGPRS, 1, 2, 3 and 4 timeslots has been activated separately with power level 6(850 MHz band) and 5(1900 MHz band).
5. According to KDB941225D01-SAR for GPRS and EDGE modes are not required when the source-based time-averaged output power for each data mode is lower than that in the normal GSM voice mode

WCDMA 850

Test Condition	Test Mode	3GPP Sub Test	Averaged Mean Power (dBm)		
			Low Frequency	Mid Frequency	High Frequency
Normal	RMC12.2k		22.71	22.47	22.61
	HSDPA	1	21.87	21.52	21.73
		2	22.01	21.69	21.79
		3	21.71	21.33	21.81
		4	21.87	21.18	21.78
	HSUPA	1	21.75	21.46	21.54
		2	21.81	21.32	21.62
		3	21.74	21.32	21.87
		4	21.76	21.24	21.62
		5	21.83	21.66	21.89
	DC-HSDPA	1	21.23	21.02	21.18
		2	21.30	20.99	21.16
		3	21.25	21.15	21.39
		4	21.30	21.05	21.28
	HSPA+ (16QAM)	1	21.22	21.00	21.40

WCDMA 1900

Test Condition	Test Mode	3GPP Sub Test	Averaged Mean Power (dBm)		
			Low Frequency	Mid Frequency	High Frequency
Normal	RMC12.2k		22.81	22.79	22.89
	HSDPA	1	22.12	22.00	22.08
		2	21.97	22.21	22.19
		3	22.02	22.07	22.13
		4	22.00	22.16	22.27
	HSUPA	1	21.94	22.13	22.17
		2	22.12	21.99	22.26
		3	21.97	21.96	22.06
		4	22.00	22.06	22.23
		5	22.01	22.13	22.30
	DC-HSDPA	1	21.49	21.59	21.58
		2	21.41	21.54	21.71
		3	21.44	21.67	21.58
		4	21.54	21.52	21.68
	HSPA+ (16QAM)	1	21.50	21.57	21.75

Note:

1. The default test configuration is to measure SAR with an established radio link between the EUT and a communication test set using a 12.2 kbps RMC (reference measurement Channel) Configured in Test Loop Model 1.
2. KDB 941225 D01-Body SAR is not required for HSDPA/HSUPA when the maximum average output of each RF channel is less than ¼ dB higher than measured 12.2kbps RMC or the maximum SAR for 12.2kbps RMC is < 75% of SAR limit.

LTE Band 2:

BW	Modulation	Resource Block Size& Resource Block Offset	Target MPR	Meas MPR	Ave Tx Power (dBm)		
					Low Channel	Mid Channel	High Channel
					1850.7MHz	1880MHz	1909.3MHz
1.4M	QPSK	RB Size=1, RB Offset=0	0	0	22.90	22.98	22.78
		RB Size=1, RB Offset=2	0	0	23.06	23.03	22.85
		RB Size=1, RB Offset=5	0	0	23.08	23.03	22.78
		RB Size=3, RB Offset=0	1	1	22.59	23.04	22.17
		RB Size=3, RB Offset=1	1	1	22.42	22.89	22.20
		RB Size=3, RB Offset=2	1	1	22.24	22.91	22.19
	16QAM	RB Size=6, RB Offset=0	1	1	21.56	21.85	21.52
		RB Size=1, RB Offset=0	1	1	22.54	22.68	22.23
		RB Size=1, RB Offset=2	1	1	22.79	22.56	22.13
		RB Size=1, RB Offset=5	1	1	22.63	22.68	21.97
		RB Size=3, RB Offset=0	2	2	22.04	22.73	21.65
		RB Size=3, RB Offset=1	2	2	21.83	22.76	21.95
		RB Size=3, RB Offset=2	2	2	22.02	22.64	21.87
RB Size=6, RB Offset=0	2	2	21.23	20.90	21.28		
BW	Modulation	Resource Block Size& Resource Block Offset	Target MPR	Meas MPR	Ave Tx Power (dBm)		
					Low Channel	Mid Channel	High Channel
					1851.5MHz	1880MHz	1908.5MHz
3M	QPSK	RB Size=1, RB Offset=0	0	0	22.75	22.54	22.82
		RB Size=1, RB Offset=7	0	0	22.67	22.71	22.44
		RB Size=1, RB Offset=14	0	0	22.65	22.74	22.35
		RB Size=8, RB Offset=0	1	1	22.31	22.28	22.19
		RB Size=8, RB Offset=4	1	1	22.24	22.32	22.19
		RB Size=8, RB Offset=7	1	1	22.15	22.13	22.07
	16QAM	RB Size=15, RB Offset=0	1	1	21.28	21.32	21.24
		RB Size=1, RB Offset=0	1	1	22.66	22.22	22.17
		RB Size=1, RB Offset=7	1	1	22.70	22.13	21.98
		RB Size=1, RB Offset=14	1	1	22.69	22.06	22.13
		RB Size=8, RB Offset=0	2	2	21.87	21.70	21.69
		RB Size=8, RB Offset=4	2	2	22.21	21.52	21.72
		RB Size=8, RB Offset=7	2	2	21.91	21.85	21.86
RB Size=15, RB Offset=0	2	2	21.12	21.11	20.93		
BW	Modulation	Resource Block Size& Resource Block Offset	Target MPR	Meas MPR	Ave Tx Power (dBm)		
					Low Channel	Mid Channel	High Channel
					1852.5MHz	1880MHz	1907.5MHz
5M	QPSK	RB Size=1, RB Offset=0	0	0	23.19	22.50	22.87
		RB Size=1, RB Offset=12	0	0	22.94	22.32	22.33
		RB Size=1, RB Offset=24	0	0	22.75	20.36	22.49

BW	Modulation	Resource Block Size& Resource Block Offset	Target MPR	Meas MPR	Ave Tx Power (dBm)		
					Low Channel	Mid Channel	High Channel
					1855MHz	1880MHz	1905MHz
	16QAM	RB Size=12, RB Offset=0	1	1	21.78	21.78	21.77
		RB Size=12, RB Offset=6	1	1	22.07	21.57	22.00
		RB Size=12, RB Offset=11	1	1	21.81	21.60	21.82
		RB Size=25, RB Offset=0	1	1	21.19	21.18	21.11
		RB Size=1, RB Offset=0	1	1	22.05	21.74	22.11
		RB Size=1, RB Offset=12	1	1	22.08	21.56	21.98
		RB Size=1, RB Offset=24	1	1	21.46	21.47	22.12
		RB Size=12, RB Offset=0	2	2	21.81	21.55	21.35
		RB Size=12, RB Offset=6	2	2	21.65	21.73	21.43
		RB Size=12, RB Offset=11	2	2	21.70	21.27	21.42
		RB Size=25, RB Offset=0	2	2	20.97	20.96	20.81
10M	QPSK	RB Size=1, RB Offset=0	0	0	22.74	22.39	22.39
		RB Size=1, RB Offset=24	0	0	23.06	22.29	22.39
		RB Size=1, RB Offset=49	0	0	22.59	22.39	22.52
		RB Size=25, RB Offset=0	1	1	22.06	21.75	21.68
		RB Size=25, RB Offset=12	1	1	22.31	21.84	21.96
		RB Size=25, RB Offset=24	1	1	22.14	21.76	21.96
	16QAM	RB Size=50, RB Offset=0	1	1	21.60	21.11	21.09
		RB Size=1, RB Offset=0	1	1	22.54	22.22	21.99
		RB Size=1, RB Offset=24	1	1	22.36	22.13	22.05
		RB Size=1, RB Offset=49	1	1	21.33	21.89	21.89
		RB Size=25, RB Offset=0	2	2	21.93	21.73	21.32
		RB Size=25, RB Offset=12	2	2	21.74	21.80	21.42
		RB Size=25, RB Offset=24	2	2	20.83	20.95	21.34
		RB Size=50, RB Offset=0	2	2	20.80	20.62	20.43
BW	Modulation	Resource Block Size& Resource Block Offset	Target MPR	Meas MPR	Ave Tx Power (dBm)		
					Low Channel	Mid Channel	High Channel
					1857.5MHz	1880MHz	1902.5MHz
15M	QPSK	RB Size=1, RB Offset=0	0	0	22.54	22.58	22.63
		RB Size=1, RB Offset=37	0	0	22.53	22.67	22.64
		RB Size=1, RB Offset=74	0	0	22.39	22.57	22.45
		RB Size=36, RB Offset=0	1	1	22.00	22.02	22.03
		RB Size=36, RB Offset=18	1	1	21.98	22.19	22.08
		RB Size=36, RB Offset=37	1	1	21.78	22.22	22.32
		RB Size=75, RB Offset=0	1	1	21.78	21.06	21.12
	16QAM	RB Size=1, RB Offset=0	1	1	22.43	21.96	22.12
		RB Size=1, RB Offset=37	1	1	22.37	21.64	21.81
		RB Size=1, RB Offset=74	1	1	22.28	21.61	21.98
		RB Size=36, RB Offset=0	2	2	21.67	20.68	21.05
		RB Size=36, RB Offset=18	2	2	21.84	21.12	21.26
		RB Size=36, RB Offset=37	2	2	21.72	20.94	21.15
		RB Size=75, RB Offset=0	2	2	20.90	20.41	20.24
BW	Modulation	Resource Block Size& Resource Block Offset	Target MPR	Meas MPR	Ave Tx Power (dBm)		
					Low Channel	Mid Channel	High Channel
					1860MHz	1880MHz	1900MHz

20M	QPSK	RB Size=1, RB Offset=0	0	0	22.54	22.15	22.36
		RB Size=1, RB Offset=49	0	0	22.66	22.31	22.68
		RB Size=1, RB Offset=99	0	0	22.61	22.52	22.50
		RB Size=50, RB Offset=0	1	1	21.92	21.52	22.13
		RB Size=50, RB Offset=24	1	1	21.75	21.64	22.26
		RB Size=50, RB Offset=49	1	1	21.99	21.92	21.98
		RB Size=100, RB Offset=0	1	1	21.76	21.09	21.14
	16QAM	RB Size=1, RB Offset=0	1	1	22.12	21.99	22.14
		RB Size=1, RB Offset=49	1	1	22.36	21.85	22.04
		RB Size=1, RB Offset=99	1	1	22.23	21.89	22.27
		RB Size=50, RB Offset=0	2	2	21.55	21.14	21.24
		RB Size=50, RB Offset=24	2	2	21.51	21.39	21.36
		RB Size=50, RB Offset=49	2	2	21.44	21.30	21.20
		RB Size=100, RB Offset=0	2	2	20.51	20.70	20.68

LTE Band 4:

BW	Modulation	Resource Block Size& Resource Block Offset	Target MPR	Meas MPR	Ave Tx Power (dBm)		
					Low Channel	Mid Channel	High Channel
					1710.7MHz	1732.5MHz	1754.3MHz
1.4M	QPSK	RB Size=1, RB Offset=0	0	0	22.54	22.32	22.27
		RB Size=1, RB Offset=2	0	0	22.85	22.27	22.33
		RB Size=1, RB Offset=5	0	0	22.47	22.25	22.38
		RB Size=3, RB Offset=0	1	1	22.11	21.54	21.62
		RB Size=3, RB Offset=1	1	1	22.29	21.62	21.84
		RB Size=3, RB Offset=2	1	1	22.21	21.57	21.74
		RB Size=6, RB Offset=0	1	1	21.56	21.24	21.19
	16QAM	RB Size=1, RB Offset=0	1	1	22.42	22.31	21.86
		RB Size=1, RB Offset=2	1	1	22.31	22.15	22.13
		RB Size=1, RB Offset=5	1	1	21.31	21.68	21.85
		RB Size=3, RB Offset=0	2	2	21.75	21.69	21.24
		RB Size=3, RB Offset=1	2	2	21.54	21.63	21.32
		RB Size=3, RB Offset=2	2	2	20.66	20.81	21.23
		RB Size=6, RB Offset=0	2	2	20.65	20.49	20.30
BW	Modulation	Resource Block Size& Resource Block Offset	Target MPR	Meas MPR	Ave Tx Power (dBm)		
					Low Channel	Mid Channel	High Channel
					1711.5MHz	1732.5MHz	1753.5MHz
3M	QPSK	RB Size=1, RB Offset=0	0	0	22.62	22.54	22.65
		RB Size=1, RB Offset=7	0	0	22.53	22.56	22.36
		RB Size=1, RB Offset=14	0	0	22.58	22.61	22.27
		RB Size=8, RB Offset=0	1	1	22.42	22.33	22.16
		RB Size=8, RB Offset=4	1	1	22.27	22.28	22.23
		RB Size=8, RB Offset=7	1	1	22.13	22.26	22.14
		RB Size=15, RB Offset=0	1	1	21.21	21.19	21.19
	16QAM	RB Size=1, RB Offset=0	1	1	22.65	22.39	22.59
		RB Size=1, RB Offset=7	1	1	22.47	22.58	22.53
		RB Size=1, RB Offset=14	1	1	22.52	22.64	22.42

BW	Modulation	Resource Block Size& Resource Block Offset	Target MPR	Meas MPR	Ave Tx Power (dBm)		
					Low Channel	Mid Channel	High Channel
					1712.5MHz	1732.5MHz	1752.5MHz
		RB Size=8, RB Offset=0	2	2	22.43	22.21	22.15
		RB Size=8, RB Offset=4	2	2	22.19	22.23	22.27
		RB Size=8, RB Offset=7	2	2	22.20	22.34	22.16
		RB Size=15, RB Offset=0	2	2	21.17	21.28	21.34
5M	QPSK	RB Size=1, RB Offset=0	0	0	22.53	22.42	22.57
		RB Size=1, RB Offset=12	0	0	22.44	22.56	22.32
		RB Size=1, RB Offset=24	0	0	22.47	22.49	22.42
		RB Size=12, RB Offset=0	1	1	22.29	22.17	22.15
		RB Size=12, RB Offset=6	1	1	22.18	22.25	22.24
		RB Size=12, RB Offset=11	1	1	22.23	22.26	22.32
		RB Size=25, RB Offset=0	1	1	21.16	21.27	21.35
	16QAM	RB Size=1, RB Offset=0	1	1	21.87	21.53	21.92
		RB Size=1, RB Offset=12	1	1	21.86	21.38	21.75
		RB Size=1, RB Offset=24	1	1	21.29	21.25	21.53
		RB Size=12, RB Offset=0	2	2	21.53	21.48	21.22
		RB Size=12, RB Offset=6	2	2	21.32	21.42	21.37
		RB Size=12, RB Offset=11	2	2	21.56	21.18	21.32
		RB Size=25, RB Offset=0	2	2	20.72	20.67	20.64
BW	Modulation	Resource Block Size& Resource Block Offset	Target MPR	Meas MPR	Ave Tx Power (dBm)		
					Low Channel	Mid Channel	High Channel
					1715MHz	1732.5MHz	1750MHz
10M	QPSK	RB Size=1, RB Offset=0	0	0	22.65	22.28	22.32
		RB Size=1, RB Offset=24	0	0	22.43	22.21	22.15
		RB Size=1, RB Offset=49	0	0	22.32	22.26	22.31
		RB Size=25, RB Offset=0	1	1	21.86	21.63	21.43
		RB Size=25, RB Offset=12	1	1	22.13	21.65	21.52
		RB Size=25, RB Offset=24	1	1	22.11	21.46	21.33
		RB Size=50, RB Offset=0	1	1	21.52	21.24	21.17
	16QAM	RB Size=1, RB Offset=0	1	1	22.36	22.14	21.85
		RB Size=1, RB Offset=24	1	1	22.21	22.06	21.98
		RB Size=1, RB Offset=49	1	1	21.19	21.75	21.63
		RB Size=25, RB Offset=0	2	2	21.72	21.54	21.15
		RB Size=25, RB Offset=12	2	2	21.51	21.44	21.37
		RB Size=25, RB Offset=24	2	2	20.72	20.63	21.16
		RB Size=50, RB Offset=0	2	2	20.63	20.41	20.22
BW	Modulation	Resource Block Size& Resource Block Offset	Target MPR	Meas MPR	Ave Tx Power (dBm)		
					Low Channel	Mid Channel	High Channel
					1717.5MHz	1732.5MHz	1747.5MHz
15M	QPSK	RB Size=1, RB Offset=0	0	0	22.51	22.45	22.54
		RB Size=1, RB Offset=37	0	0	22.49	22.52	22.51
		RB Size=1, RB Offset=74	0	0	22.31	22.42	22.34
		RB Size=36, RB Offset=0	1	1	21.95	22.05	22.12
		RB Size=36, RB Offset=18	1	1	21.83	22.14	22.11
		RB Size=36, RB Offset=37	1	1	21.56	22.16	22.21
		RB Size=75, RB Offset=0	1	1	21.64	21.13	21.15

BW	Modulation	Resource Block Size & Resource Block Offset	Target MPR	Meas MPR	Ave Tx Power (dBm)		
					Low Channel	Mid Channel	High Channel
					1720MHz	1732.5MHz	1745MHz
	16QAM	RB Size=1, RB Offset=0	1	1	22.31	21.82	22.04
		RB Size=1, RB Offset=37	1	1	22.28	21.41	21.62
		RB Size=1, RB Offset=74	1	1	22.16	21.42	21.76
		RB Size=36, RB Offset=0	2	2	21.54	20.54	21.11
		RB Size=36, RB Offset=18	2	2	21.61	21.15	21.13
		RB Size=36, RB Offset=37	2	2	21.53	20.71	21.23
		RB Size=75, RB Offset=0	2	2	20.71	20.25	20.18
20M	QPSK	RB Size=1, RB Offset=0	0	0	22.43	22.12	22.24
		RB Size=1, RB Offset=49	0	0	22.41	22.13	22.45
		RB Size=1, RB Offset=99	0	0	22.53	22.34	22.37
		RB Size=50, RB Offset=0	1	1	21.73	21.35	22.17
		RB Size=50, RB Offset=24	1	1	21.52	21.42	22.13
		RB Size=50, RB Offset=49	1	1	21.75	21.83	21.84
		RB Size=100, RB Offset=0	1	1	21.52	21.12	21.12
	16QAM	RB Size=1, RB Offset=0	1	1	22.13	21.75	21.98
		RB Size=1, RB Offset=49	1	1	22.14	21.63	21.87
		RB Size=1, RB Offset=99	1	1	22.15	21.65	22.17
		RB Size=50, RB Offset=0	2	2	21.37	21.21	21.18
		RB Size=50, RB Offset=24	2	2	21.43	21.35	21.24
		RB Size=50, RB Offset=49	2	2	21.25	21.27	21.16
		RB Size=100, RB Offset=0	2	2	20.34	20.49	20.57

Note:

1. SAR for LTE band exposure configurations is measured according to the procedures of KDB 941225 D05 SAR for LTE Devices v02.
2. The CMW500 Wideband Radio Communication tester is used for LTE output power measurements and SAR testing. Closed loop power control is used to keep the radio transmitters the max output power during the test.
3. KDB941225D05v02- SAR for higher order modulation is required only when the highest maximum output power for the configuration in the higher order modulation is > 1/2 dB higher than the same configuration in QPSK or when the reported SAR for the QPSK configuration is > 1.45 W/kg

Bluetooth

Mode	Channel No.	Frequency (MHz)	Conducted Output Power	
			(dBm)	(mw)
BDR(GFSK)	0	2402	-1.35	0.733
	39	2441	4.56	2.858
	78	2480	-3.13	0.486
EDR(4-DQPSK)	0	2402	3.02	2.004
	39	2441	1.71	1.483
	78	2480	-2.18	0.605
EDR-8DPSK	0	2402	3.27	2.123
	39	2441	-3.64	0.433
	78	2480	2.20	1.660
BT4.0	0	2402	-8.29	0.148
	19	2440	-9.41	0.115
	39	2480	-5.96	0.254

Wi-Fi

Band	Channel No.	Frequency (MHz)	Conducted Output Power	
			(dBm)	(mw)
802.11b	1	2412	8.71	7.430
	6	2437	8.29	6.745
	11	2462	8.61	7.261
802.11g	1	2412	8.95	7.852
	6	2437	9.17	8.260
	11	2462	8.62	7.278
802.11n HT20	1	2412	8.76	7.516
	6	2437	8.27	6.714
	11	2462	8.25	6.683
802.11n HT40	1	2422	9.01	7.962
	4	2437	8.82	7.621
	7	2452	7.55	5.689

Note:

1. The output power was tested under data rate 1Mbps for 802.11b, 6Mbps for 802.11g, 6.5Mbps for 802.11n HT20, 13.5Mbps for 802.11n HT40.

SAR MEASUREMENT RESULTS

This page summarizes the results of the performed dosimetric evaluation.

SAR Test Data

Environmental Conditions

Temperature:	21-24 °C
Relative Humidity:	50-53 %
ATM Pressure:	1001-1002 mbar

Testing was performed by Terry XiaHou on 2015-10-06

GSM 850:

EUT Position	Frequency (MHz)	Test Mode	Power Drift (%)	Max. Meas. Power (dBm)	Max. Rated Power (dBm)	1g SAR (W/Kg)			
						Scaled Factor	Meas. SAR	Scaled SAR	Plot
Left Head Cheek	824.2	GSM	/	/	/	/	/	/	/
	836.6	GSM	-1.981	32.73	32.80	1.016	0.746	0.758	1#
	848.8	GSM	/	/	/	/	/	/	/
Left Head Tilt	824.2	GSM	/	/	/	/	/	/	/
	836.6	GSM	-3.058	32.73	32.80	1.016	0.447	0.454	/
	848.8	GSM	/	/	/	/	/	/	/
Right Head Cheek	824.2	GSM	/	/	/	/	/	/	/
	836.6	GSM	-1.496	32.73	32.80	1.016	0.689	0.700	/
	848.8	GSM	/	/	/	/	/	/	/
Right Head Tilt	824.2	GSM	/	/	/	/	/	/	/
	836.6	GSM	-2.853	32.73	32.80	1.016	0.414	0.421	/
	848.8	GSM	/	/	/	/	/	/	/
Body-Back-Headset (10mm)	824.2	GSM	/	/	/	/	/	/	/
	836.6	GSM	1.234	32.73	32.80	1.016	0.883	0.897	/
	848.8	GSM	/	/	/	/	/	/	/

Note:

1. When the 1-g SAR is ≤ 0.8 W/Kg, testing for other channels are optional.
2. The EUT transmit and receive through the same GSM antenna while testing SAR.
3. When SAR or MPE is not measured at the maximum power level allowed for production units, the results must be scaled to the maximum tune-up tolerance limit according to the power applied to the individual channels tested to determine compliance.
4. When the maximum output power variation across the required test channels is $> \frac{1}{2}$ dB, instead of the middle channel, the highest output power channel must be used.

PCS Band:

EUT Position	Frequency (MHz)	Test Mode	Power Drift (%)	Max. Meas. Power (dBm)	Max. Rated Power (dBm)	1g SAR (W/Kg)			
						Scaled Factor	Meas. SAR	Scaled SAR	Plot
Left Head Cheek	1850.2	GSM	/	/	/	/	/	/	/
	1880	GSM	2.287	28.33	28.50	1.040	0.118	0.123	2#
	1909.8	GSM	/	/	/	/	/	/	/
Left Head Tilt	1850.2	GSM	/	/	/	/	/	/	/
	1880	GSM	-2.824	28.33	28.50	1.040	0.075	0.078	/
	1909.8	GSM	/	/	/	/	/	/	/
Right Head Cheek	1850.2	GSM	/	/	/	/	/	/	/
	1880	GSM	-1.707	28.33	28.50	1.040	0.113	0.118	/
	1909.8	GSM	/	/	/	/	/	/	/
Right Head Tilt	1850.2	GSM	/	/	/	/	/	/	/
	1880	GSM	1.204	28.33	28.50	1.040	0.077	0.080	/
	1909.8	GSM	/	/	/	/	/	/	/
Body-Back-Headset (10mm)	1850.2	GSM	/	/	/	/	/	/	/
	1880	GSM	-1.888	28.33	28.50	1.040	0.134	0.139	/
	1909.8	GSM	/	/	/	/	/	/	/

Note:

1. When the 1-g SAR is $\leq 0.8\text{W/Kg}$, testing for other channels are optional.
2. The EUT transmit and receive through the same GSM antenna while testing SAR.
3. When SAR or MPE is not measured at the maximum power level allowed for production units, the results must be scaled to the maximum tune-up tolerance limit according to the power applied to the individual channels tested to determine compliance.
4. When the maximum output power variation across the required test channels is $> \frac{1}{2}$ dB, instead of the middle channel, the highest output power channel must be used.

WCDMA 850 Band:

EUT Position	Frequency (MHz)	Test Mode	Power Drift (%)	Max. Meas. Power (dBm)	Max. Rated Power (dBm)	1g SAR (W/Kg)			
						Scaled Factor	Meas. SAR	Scaled SAR	Plot
Left Head Cheek	826.4	RMC	/	/	/	/	/	/	/
	836.6	RMC	0.571	22.47	22.80	1.079	0.312	0.337	/
	846.6	RMC	/	/	/	/	/	/	/
Left Head Tilt	826.4	RMC	/	/	/	/	/	/	/
	836.6	RMC	0.808	22.47	22.80	1.079	0.163	0.176	/
	846.6	RMC	/	/	/	/	/	/	/
Right Head Cheek	826.4	RMC	/	/	/	/	/	/	/
	836.6	RMC	1.177	22.47	22.80	1.079	0.338	0.365	3#
	846.6	RMC	/	/	/	/	/	/	/
Right Head Tilt	826.4	RMC	/	/	/	/	/	/	/
	836.6	RMC	2.252	22.47	22.80	1.079	0.182	0.196	/
	846.6	RMC	/	/	/	/	/	/	/

WCDMA 1900 Band:

EUT Position	Frequency (MHz)	Test Mode	Power Drift (%)	Max. Meas. Power (dBm)	Max. Rated Power (dBm)	1g SAR (W/Kg)			
						Scaled Factor	Meas. SAR	Scaled SAR	Plot
Left Head Cheek	1852.4	RMC	/	/	/	/	/	/	/
	1880	RMC	-1.680	22.79	22.90	1.026	0.361	0.370	4#
	1907.6	RMC	/	/	/	/	/	/	/
Left Head Tilt	1852.4	RMC	/	/	/	/	/	/	/
	1880	RMC	3.523	22.79	22.90	1.026	0.176	0.181	/
	1907.6	RMC	/	/	/	/	/	/	/
Right Head Cheek	1852.4	RMC	/	/	/	/	/	/	/
	1880	RMC	2.145	22.79	22.90	1.026	0.344	0.353	/
	1907.6	RMC	/	/	/	/	/	/	/
Right Head Tilt	1852.4	RMC	/	/	/	/	/	/	/
	1880	RMC	-0.641	22.79	22.90	1.026	0.185	0.190	/
	1907.6	RMC	/	/	/	/	/	/	/

Note:

1. When the 1-g SAR is ≤ 0.8 W/Kg, testing for other channels are optional.
2. The EUT transmit and receive through the same antenna while testing SAR.
3. The default test configuration is to measure SAR with an established radio link between the EUT and a communication test set using a 12.2 kbps RMC (reference measurement Channel) Configured in Test Loop Model.
4. KDB 941225 D01-Body SAR is not required for HSDPA/HSUPA when the maximum average output of each RF channel is less than $\frac{1}{4}$ dB higher than measured 12.2kbps RMC or the maximum SAR for 12.2kbps RMC is $< 75\%$ of SAR limit.

5. When SAR or MPE is not measured at the maximum power level allowed for production units, the results must be scaled to the maximum tune-up tolerance limit according to the power applied to the individual channels tested to determine compliance.

LTE Band 2:

EUT Position	Frequency (MHz)	Bandwidth (MHz)	Test Mode	Power Drift (%)	Max. Meas. Power (dBm)	Max. Rated Power (dBm)	1g SAR (W/Kg)			
							Scaled Factor	Meas. SAR	Scaled SAR	Plot
Left Head Cheek	1860	20	1RB, Offset=49	/	/	/	/	/	/	/
	1880	20	1RB, Offset=49	/	/	/	/	/	/	/
	1900	20	1RB, Offset=49	1.560	22.68	22.70	1.005	0.452	0.454	/
	1900	20	50%RB, Offset=24	-3.334	22.26	22.70	1.107	0.411	0.455	/
Left Head Tilt	1860	20	1RB, Offset=49	/	/	/	/	/	/	/
	1880	20	1RB, Offset=49	/	/	/	/	/	/	/
	1900	20	1RB, Offset=49	-0.871	22.68	22.70	1.005	0.253	0.254	/
	1900	20	50%RB, Offset=24	1.094	22.26	22.70	1.107	0.230	0.255	/
Right Head Cheek	1860	20	1RB, Offset=49	/	/	/	/	/	/	/
	1880	20	1RB, Offset=49	/	/	/	/	/	/	/
	1900	20	1RB, Offset=49	-0.946	22.68	22.70	1.005	0.491	0.493	5#
	1900	20	50%RB, Offset=24	2.995	22.26	22.70	1.107	0.432	0.478	/
Right Head Tilt	1860	20	1RB, Offset=49	/	/	/	/	/	/	/
	1880	20	1RB, Offset=49	/	/	/	/	/	/	/
	1900	20	1RB, Offset=49	-2.074	22.68	22.70	1.005	0.279	0.280	/
	1900	20	50%RB, Offset=24	2.631	22.26	22.70	1.107	0.244	0.270	/

LTE Band 4:

EUT Position	Frequency (MHz)	Bandwidth (MHz)	Test Mode	Power Drift (%)	Max. Meas. Power (dBm)	Max. Rated Power (dBm)	1g SAR (W/Kg)			
							Scaled Factor	Meas. SAR	Scaled SAR	Plot
Left Head Cheek	1720	20	1RB, Offset=99	-2.714	22.53	22.60	1.016	0.338	0.343	6#
	1732.5	20	1RB, Offset=99	/	/	/	/	/	/	/
	1745	20	1RB, Offset=99	/	/	/	/	/	/	/
	1720	20	50%RB, Offset=49	3.167	21.75	22.60	1.216	0.235	0.286	/
Left Head Tilt	1720	20	1RB, Offset=99	-1.064	22.53	22.60	1.016	0.182	0.185	/
	1732.5	20	1RB, Offset=99	/	/	/	/	/	/	/
	1745	20	1RB, Offset=99	/	/	/	/	/	/	/
	1720	20	50%RB, Offset=49	-3.504	21.75	22.60	1.216	0.130	0.158	/
Right Head Cheek	1720	20	1RB, Offset=99	3.415	22.53	22.60	1.016	0.317	0.322	/
	1732.5	20	1RB, Offset=99	/	/	/	/	/	/	/
	1745	20	1RB, Offset=99	/	/	/	/	/	/	/
	1720	20	50%RB, Offset=49	1.802	21.75	22.60	1.216	0.203	0.247	/
Right Head Tilt	1720	20	1RB, Offset=99	1.998	22.53	22.60	1.016	0.167	0.170	/
	1732.5	20	1RB, Offset=99	/	/	/	/	/	/	/
	1745	20	1RB, Offset=99	/	/	/	/	/	/	/
	1720	20	50%RB, Offset=49	1.823	21.75	22.60	1.216	0.138	0.168	/

Note:

1. When the 1-g SAR is $\leq 0.8W/Kg$, testing for other channels are optional.
2. SAR for LTE band exposure configurations is measured according to the procedures of KDB 941225 D05 SAR for LTE Devices v02.
3. KDB941225D05- SAR for higher order modulation is required only when the highest maximum output power for the configuration in the higher order modulation is $> \frac{1}{2}$ dB higher than the same configuration in QPSK or when the reported SAR for the QPSK configuration is $> 1.45 W/kg$
4. KDB941225D05- For QPSK with 100% RB allocation, when the reported SAR measured for the Highest output power channel is $<1.45 W/kg$, tests for the remaining required test channels are optional.
5. KDB941225D05- For QPSK with 100% RB allocation, SAR is not required when the highest maximum output power for 100 % RB allocation is less than the highest maximum output power in 50% and 1 RB allocations and the highest reported SAR for 1 RB and 50% RB allocation are $\leq 0.8 W/kg$.
6. KDB941225D05- Start with the largest channel bandwidth (20M) and measure SAR for QPSK with 1 RB allocation, using the RB offset and required test channel combination with the highest maximum output power among RB offset the upper edge, middle and lower edge of each required test channel.
7. Worst case SAR for 50% RB allocation is selected to be tested.

Mobile Hot-Spot Test Result

The DUT is capable of functioning as a Wi-Fi to Cellular Mobile hotspot. Additional SAR testing was performed according to KDB 941225 D06. Testing was performed with a separation of 1cm between the DUT and the flat phantom. The DUT was positioned for SAR tests with the front and back surfaces facing the phantom, and also with the edges facing the phantom in which the transmitting antenna is <2.5 cm from the edge. Each transmit band was utilized for SAR testing. The tested mode has been selected within each band that exhibits the highest time average output power.

Hot spot-GPRS (Frequency Band: 850)

EUT Position	Frequency (MHz)	Test Mode	Power Drift (%)	Max. Meas. Power (dBm)	Max. Rated Power (dBm)	1g SAR (W/Kg)			
						Scaled Factor	Meas. SAR	Scaled SAR	Plot
Body-Back (10mm)	824.2	GPRS	-2.890	29.22	29.40	1.042	0.969	1.010	/
	836.6	GPRS	0.785	29.33	29.40	1.016	1.253	1.273	7#
	848.8	GPRS	2.408	29.18	29.40	1.052	1.135	1.194	/
Body-Left (10mm)	824.2	GPRS	-0.602	29.22	29.40	1.042	0.725	0.756	/
	836.6	GPRS	2.775	29.33	29.40	1.016	0.833	0.847	/
	848.8	GPRS	-2.210	29.18	29.40	1.052	0.850	0.894	/
Body-Right (10mm)	824.2	GPRS	/	/	/	/	/	/	/
	836.6	GPRS	-2.697	29.33	29.40	1.016	0.756	0.768	/
	848.8	GPRS	/	/	/	/	/	/	/
Body-Bottom (10mm)	824.2	GPRS	/	/	/	/	/	/	/
	836.6	GPRS	0.882	29.33	29.40	1.016	0.389	0.395	/
	848.8	GPRS	/	/	/	/	/	/	/

Note:

1. When the 1-g SAR is $\leq 0.8W/Kg$, testing for other channels are optional.
2. According to IEEE 1528-2013, the middle channel is required to be tested first.
3. KDB 447498D01- When the maximum output power variation across the required test channels is $> \frac{1}{2}$ dB, instead of the middle channel, the highest output power channel must be used.
2. The EUT is a Capability Class B mobile phone which can be attached to both GPRS and GSM services.
3. The Multi-slot Classes of EUT is Class12 which has maximum 4 Downlink slots and 4 Uplink slots, the maximum active slots is 5, when perform the multiple slots scan, 3DL+2UL is the worst case.

4. The EUT transmit and receive through the same GSM antenna while testing SAR.
5. When SAR or MPE is not measured at the maximum power level allowed for production units, the results must be scaled to the maximum tune-up tolerance limit according to the power applied to the individual channels tested to determine compliance.

Hot spot-GPRS (Frequency Band: 1900)

EUT Position	Frequency (MHz)	Test Mode	Power Drift (%)	Max. Meas. Power (dBm)	Max. Rated Power (dBm)	1g SAR (W/Kg)			
						Scaled Factor	Meas. SAR	Scaled SAR	Plot
Body-Back (10mm)	1850.2	GPRS	/	/	/	/	/	/	/
	1880.0	GPRS	2.988	24.64	24.80	1.038	0.182	0.189	8#
	1909.8	GPRS	/	/	/	/	/	/	/
Body-Left (10mm)	1850.2	GPRS	/	/	/	/	/	/	/
	1880.0	GPRS	-2.152	24.64	24.80	1.038	0.077	0.080	/
	1909.8	GPRS	/	/	/	/	/	/	/
Body-Right (10mm)	1850.2	GPRS	/	/	/	/	/	/	/
	1880.0	GPRS	-1.347	24.64	24.80	1.038	0.073	0.076	/
	1909.8	GPRS	/	/	/	/	/	/	/
Body-Bottom (10mm)	1850.2	GPRS	/	/	/	/	/	/	/
	1880.0	GPRS	2.369	24.64	24.80	1.038	0.153	0.159	/
	1909.8	GPRS	/	/	/	/	/	/	/

Note:

1. When the 1-g SAR is $\leq 0.8\text{W/Kg}$, testing for other channels are optional.
2. According to IEEE 1528-2013, the middle channel is required to be tested first.
3. KDB 447498D01- When the maximum output power variation across the required test channels is $> \frac{1}{2}$ dB, instead of the middle channel, the highest output power channel must be used.
4. The EUT is a Capability Class B mobile phone which can be attached to both GPRS and GSM services.
5. The Multi-slot Classes of EUT is Class12 which has maximum 4 Downlink slots and 4 Uplink slots, the maximum active slots is 5, when perform the multiple slots scan, 1DL+4UL is the worst case.
6. The EUT transmit and receive through the same GSM antenna while testing SAR.
7. When SAR or MPE is not measured at the maximum power level allowed for production units, the results must be scaled to the maximum tune-up tolerance limit according to the power applied to the individual channels tested to determine compliance.

Hot Spot-WCDMA 850 Band

EUT Position	Frequency (MHz)	Test Mode	Power Drift (%)	Max. Meas. Power (dBm)	Max. Rated Power (dBm)	1g SAR (W/Kg)			
						Scaled Factor	Meas. SAR	Scaled SAR	Plot
Body-Back (10mm)	826.4	RMC	/	/	/	/	/	/	/
	836.6	RMC	-0.892	22.47	22.80	1.079	0.503	0.543	9#
	846.6	RMC	/	/	/	/	/	/	/
Body-Left (10mm)	826.4	RMC	/	/	/	/	/	/	/
	836.6	RMC	-2.843	22.47	22.80	1.079	0.336	0.363	/
	846.6	RMC	/	/	/	/	/	/	/
Body-Right (10mm)	826.4	RMC	/	/	/	/	/	/	/
	836.6	RMC	-1.743	22.47	22.80	1.079	0.379	0.409	/
	846.6	RMC	/	/	/	/	/	/	/
Body-Bottom (10mm)	826.4	RMC	/	/	/	/	/	/	/
	836.6	RMC	-2.162	22.47	22.80	1.079	0.171	0.184	/
	846.6	RMC	/	/	/	/	/	/	/

Hot Spot-WCDMA 1900 Band

EUT Position	Frequency (MHz)	Test Mode	Power Drift (%)	Max. Meas. Power (dBm)	Max. Rated Power (dBm)	1g SAR (W/Kg)			
						Scaled Factor	Meas. SAR	Scaled SAR	Plot
Body-Back (10mm)	1852.4	RMC	/	/	/	/	/	/	/
	1880.0	RMC	1.153	22.79	22.90	1.026	0.542	0.556	10#
	1907.6	RMC	/	/	/	/	/	/	/
Body-Left (10mm)	1852.4	RMC	/	/	/	/	/	/	/
	1880.0	RMC	-2.287	22.79	22.90	1.026	0.239	0.245	/
	1907.6	RMC	/	/	/	/	/	/	/
Body-Right (10mm)	1852.4	RMC	/	/	/	/	/	/	/
	1880.0	RMC	3.403	22.79	22.90	1.026	0.186	0.191	/
	1907.6	RMC	/	/	/	/	/	/	/
Body-Bottom (10mm)	1852.4	RMC	/	/	/	/	/	/	/
	1880.0	RMC	2.607	22.79	22.90	1.026	0.435	0.446	/
	1907.6	RMC	/	/	/	/	/	/	/

Note:

1. When the 1-g SAR is $\leq 0.8\text{W/Kg}$, testing for other channels are optional.
2. According to IEEE 1528-2013, the middle channel is required to be tested first.
3. KDB 447498D01- When the maximum output power variation across the required test channels is $> \frac{1}{2}$ dB, instead of the middle channel, the highest output power channel must be used.
4. The default test configuration is to measure SAR with an established radio link between the EUT and a communication test set using a 12.2 kbps RMC (reference measurement Channel) Configured in Test Loop Model.
5. When SAR or MPE is not measured at the maximum power level allowed for production units, the results must be scaled to the maximum tune-up tolerance limit according to the power applied to the individual channels tested to determine compliance.

Hot Spot-LTE Band 2

EUT Position	Frequency (MHz)	Bandwidth (MHz)	Test Mode	Power Drift (%)	Max. Meas. Power (dBm)	Max. Rated Power (dBm)	1g SAR (W/Kg)			
							Scaled Factor	Meas. SAR	Scaled SAR	Plot
Body-Back (10mm)	1860	20	1RB, Offset=49	/	/	/	/	/	/	/
	1880	20	1RB, Offset=49	/	/	/	/	/	/	/
	1900	20	1RB, Offset=49	0.797	22.68	22.70	1.005	0.750	0.753	11#
	1900	20	50%RB, Offset=24	-1.809	22.26	22.70	1.107	0.639	0.707	/
Body-Left (10mm)	1860	20	1RB, Offset=49	/	/	/	/	/	/	/
	1880	20	1RB, Offset=49	/	/	/	/	/	/	/
	1900	20	1RB, Offset=49	-1.552	22.68	22.70	1.005	0.273	0.274	/
	1900	20	50%RB, Offset=24	-0.559	22.26	22.70	1.107	0.225	0.249	/
Body-Right (10mm)	1860	20	1RB, Offset=49	/	/	/	/	/	/	/
	1880	20	1RB, Offset=49	/	/	/	/	/	/	/
	1900	20	1RB, Offset=49	2.453	22.68	22.70	1.005	0.314	0.315	/
	1900	20	50%RB, Offset=24	1.222	22.26	22.70	1.107	0.236	0.261	/
Body-Bottom (10mm)	1860	20	1RB, Offset=49	/	/	/	/	/	/	/
	1880	20	1RB, Offset=49	/	/	/	/	/	/	/
	1900	20	1RB, Offset=49	-3.284	22.68	22.70	1.005	0.568	0.571	/
	1900	20	50%RB, Offset=24	1.798	22.26	22.70	1.107	0.466	0.516	/

Hot Spot-LTE Band 4

EUT Position	Frequency (MHz)	Bandwidth (MHz)	Test Mode	Power Drift (%)	Max. Meas. Power (dBm)	Max. Rated Power (dBm)	1g SAR (W/Kg)			
							Scaled Factor	Meas. SAR	Scaled SAR	Plot
Body-Back (10mm)	1720	20	1RB, Offset=99	-1.228	22.53	22.60	1.016	0.520	0.528	12#
	1732.5	20	1RB, Offset99	/	/	/	/	/	/	/
	1745	20	1RB, Offset=99	/	/	/	/	/	/	/
	1720	20	50%RB, Offset=49	-1.870	21.75	22.60	1.216	0.400	0.486	/
Body-Left (10mm)	1720	20	1RB, Offset=99	1.067	22.53	22.60	1.016	0.166	0.169	/
	1732.5	20	1RB, Offset99	/	/	/	/	/	/	/
	1745	20	1RB, Offset=99	/	/	/	/	/	/	/
	1720	20	50%RB, Offset=49	3.361	21.75	22.60	1.216	0.118	0.144	/
Body-Right (10mm)	1720	20	1RB, Offset=99	1.305	22.53	22.60	1.016	0.144	0.146	/
	1732.5	20	1RB, Offset99	/	/	/	/	/	/	/
	1745	20	1RB, Offset=99	/	/	/	/	/	/	/
	1720	20	50%RB, Offset=49	-1.497	21.75	22.60	1.216	0.106	0.129	/
Body-Bottom (10mm)	1720	20	1RB, Offset=99	-0.931	22.53	22.60	1.016	0.389	0.395	/
	1732.5	20	1RB, Offset99	/	/	/	/	/	/	/
	1745	20	1RB, Offset=99	/	/	/	/	/	/	/
	1720	20	50%RB, Offset=49	2.307	21.75	22.60	1.216	0.322	0.392	/

Note:

1. When the 1-g SAR is $\leq 0.8W/Kg$, testing for other channels are optional.

2. SAR for LTE band exposure configurations is measured according to the procedures of KDB 941225 D05 SAR for LTE Devices v02.
3. KDB941225D05- SAR for higher order modulation is required only when the highest maximum output power for the configuration in the higher order modulation is $> \frac{1}{2}$ dB higher than the same configuration in QPSK or when the reported SAR for the QPSK configuration is > 1.45 W/kg
4. KDB941225D05- For QPSK with 100% RB allocation, when the reported SAR measured for the Highest output power channel is < 1.45 W/kg, tests for the remaining required test channels are optional.
5. KDB941225D05- For QPSK with 100% RB allocation, SAR is not required when the highest maximum output power for 100 % RB allocation is less than the highest maximum output power in 50% and 1 RB allocations and the highest reported SAR for 1 RB and 50% RB allocation are ≤ 0.8 W/kg.
6. KDB941225D05- Start with the largest channel bandwidth (20M) and measure SAR for QPSK with 1 RB allocation, using the RB offset and required test channel combination with the highest maximum output power among RB offset the upper edge, middle and lower edge of each required test channel.
7. Worst case SAR for 50% RB allocation is selected to be tested.

SAR SIMULTANEOUS TRANSMISSION DESCRIPTION

BT& Wi-Fi and LTE&GSM&3G Antennas Location:

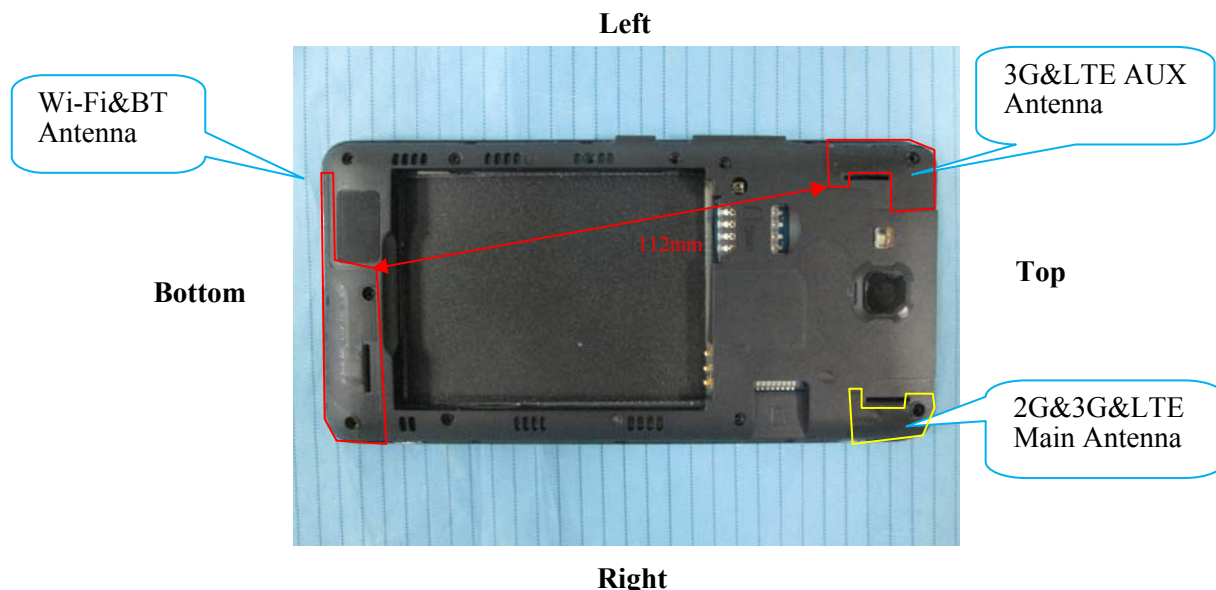

Simultaneous Transmission:

Description of Simultaneous Transmit Capabilities			Antennas Distance (mm)
Transmitter Combination	Simultaneous?	Hotspot?	
GSM + WCDMA	×	×	0
GSM + LTE	×	×	0
GSM + Bluetooth	√	×	105
GSM + Wi-Fi	√	√	105
WCDMA + LTE	×	×	0
WCDMA + Bluetooth	√	×	105
WCDMA + Wi-Fi	√	√	105
LTE+ Bluetooth	√	×	105
LTE+ Wi-Fi	√	√	105

Standalone SAR test exclusion considerations

Head Position:

Mode	Frequency (MHz)	P _{avg} (dBm)	P _{avg} (mW)	Distance (mm)	Calculated value	Threshold (1-g)	SAR Test Exclusion
Wi-Fi	2462	9.20	8.32	0	2.6	3.0	Yes
Bluetooth	2480	4.60	2.88	0	0.9	3.0	Yes

Body Position:

Mode	Frequency (MHz)	P _{avg} (dBm)	P _{avg} (Mw)	Distance (mm)	Calculated value	Threshold (1-g)	SAR Test Exclusion
Wi-Fi	2462	9.20	8.32	10.00	1.3	3.0	Yes
Bluetooth	2480	4.60	2.88	10.00	0.5	3.0	Yes

The 1-g and 10-g SAR test exclusion thresholds for 100 MHz to 6 GHz at *test separation distances* ≤ 50 mm are determined by:

$$[(\text{max. power of channel, including tune-up tolerance, mW})/(\text{min. test separation distance, mm})] \cdot [\sqrt{f(\text{GHz})}] \leq 3.0 \text{ for 1-g SAR and } \leq 7.5 \text{ for 10-g extremity SAR, where}$$

1. f(GHz) is the RF channel transmit frequency in GHz.
2. Power and distance are rounded to the nearest mW and mm before calculation.
3. The result is rounded to one decimal place for comparison.
4. When the minimum test separation distance is < 5 mm, a distance of 5 mm is applied to determine SAR test Exclusion.

Standalone SAR estimation:

Mode	Frequency (GHz)	Distance (mm)	P _{avg} (dBm)	P _{avg} (mW)	Estimated 1-g (W/kg)
BT Head	2.48	0	4.60	2.88	0.121
BT Body	2.48	10	4.60	2.88	0.061
Wi-Fi Head	2.462	0	9.20	8.32	0.349
Wi-Fi Body	2.462	10	9.20	8.32	0.174

When standalone SAR test exclusion applies to an antenna that transmits simultaneously with other antennas, the standalone SAR must be estimated according to following to determine simultaneous transmission SAR test exclusion:

$$[(\text{max. power of channel, including tune-up tolerance, mW})/(\text{min. test separation distance, mm})] \cdot [\sqrt{f(\text{GHz})/x}] \text{ W/kg for test separation distances } \leq 50 \text{ mm;}$$

where $x = 7.5$ for 1-g SAR.

When the minimum test separation distance is < 5 mm, a distance of 5 mm is applied to determine SAR test Exclusion

Simultaneous SAR test exclusion considerations:

GSM with BT:

Mode	Position	Reported SAR (W/kg)		ΣSAR
		GSM	BT	< 1.6W/kg
GSM 850	Left Head Cheek	0.758	0.121	0.879
	Left Head Tilt	0.454	0.121	0.575
	Right Head Cheek	0.700	0.121	0.821
	Right Head Tilt	0.421	0.121	0.542
	Body-Headset-Back	0.897	0.061	0.958
PCS 1900	Left Head Cheek	0.123	0.121	0.244
	Left Head Tilt	0.078	0.121	0.199
	Right Head Cheek	0.118	0.121	0.239
	Right Head Tilt	0.080	0.121	0.201
	Body-Headset-Back	0.139	0.061	0.200

WCDMA with BT:

Mode	Position	Reported SAR (W/kg)		ΣSAR
		WCDMA	BT	< 1.6W/kg
WCDMA 850	Left Head Cheek	0.337	0.121	0.458
	Left Head Tilt	0.176	0.121	0.297
	Right Head Cheek	0.365	0.121	0.486
	Right Head Tilt	0.196	0.121	0.317
WCDMA 1900	Left Head Cheek	0.370	0.121	0.491
	Left Head Tilt	0.181	0.121	0.302
	Right Head Cheek	0.353	0.121	0.474
	Right Head Tilt	0.190	0.121	0.311

LTE with BT:

Mode	Position	Reported SAR (W/kg)		ΣSAR
		LTE	BT	< 1.6W/kg
LTE Band 2	Left Head Cheek	0.455	0.121	0.576
	Left Head Tilt	0.255	0.121	0.376
	Right Head Cheek	0.493	0.121	0.614
	Right Head Tilt	0.280	0.121	0.401
LTE Band 4	Left Head Cheek	0.343	0.121	0.464
	Left Head Tilt	0.185	0.121	0.306
	Right Head Cheek	0.322	0.121	0.443
	Right Head Tilt	0.170	0.121	0.291

GSM with Wi-Fi:

Mode	Position	Reported SAR (W/kg)		ΣSAR
		GSM	Wi-Fi	< 1.6W/kg
GSM 850	Left Head Cheek	0.758	0.349	1.107
	Left Head Tilt	0.454	0.349	0.803
	Right Head Cheek	0.700	0.349	1.049
	Right Head Tilt	0.421	0.349	0.770
	Body-Headset-Back	0.897	0.174	1.071
PCS 1900	Left Head Cheek	0.123	0.349	0.472
	Left Head Tilt	0.078	0.349	0.427
	Right Head Cheek	0.118	0.349	0.467
	Right Head Tilt	0.080	0.349	0.429
	Body-Headset-Back	0.139	0.174	0.313

WCDMA with Wi-Fi:

Mode	Position	Reported SAR (W/kg)		ΣSAR
		WCDMA	Wi-Fi	< 1.6W/kg
WCDMA 850	Left Head Cheek	0.337	0.349	0.686
	Left Head Tilt	0.176	0.349	0.525
	Right Head Cheek	0.365	0.349	0.714
	Right Head Tilt	0.196	0.349	0.545
WCDMA 1900	Left Head Cheek	0.370	0.349	0.719
	Left Head Tilt	0.181	0.349	0.530
	Right Head Cheek	0.353	0.349	0.702
	Right Head Tilt	0.190	0.349	0.539

LTE with Wi-Fi:

Mode	Position	Reported SAR (W/kg)		ΣSAR
		LTE	Wi-Fi	< 1.6W/kg
LTE Band 2	Left Head Cheek	0.455	0.349	0.804
	Left Head Tilt	0.255	0.349	0.604
	Right Head Cheek	0.493	0.349	0.842
	Right Head Tilt	0.280	0.349	0.629
LTE Band 4	Left Head Cheek	0.343	0.349	0.692
	Left Head Tilt	0.185	0.349	0.534
	Right Head Cheek	0.322	0.349	0.671
	Right Head Tilt	0.170	0.349	0.519

Conclusion:

ΣSAR < 1.6 W/kg therefore simultaneous transmission SAR with Volume Scans is **not** required.

Evaluations for Simultaneous SAR, BT+GSM/3G/4G					
Test Position	Body-Back (1.0cm)	Body-Left (1.0cm)	Body-Right (1.0cm)	Body-Bottom (1.0cm)	Body-Top (1.0cm)
Mode	Stand Alone 1-g SAR (W/Kg)				
GPRS 850	1.273	0.894	0.768	0.395	/
GPRS 1900	0.189	0.080	0.076	0.159	/
WCDMA 850	0.543	0.363	0.409	0.184	/
WCDMA 1900	0.556	0.245	0.191	0.446	/
LTE Band 2	0.753	0.274	0.315	0.571	/
LTE Band 4	0.528	0.169	0.146	0.395	/
BT	0.061	0.061	0.061	0.061	0.061
	Σ 1-g SAR(W/Kg)				
GPRS 850 + BT	1.334	0.955	0.829	0.456	/
GPRS 1900 + BT	0.250	0.141	0.137	0.220	/
WCDMA 850 + BT	0.604	0.424	0.470	0.245	/
WCDMA 1900+ BT	0.617	0.306	0.252	0.507	/
LTE Band 2+ BT	0.814	0.335	0.376	0.632	/
LTE Band 4+ BT	0.589	0.230	0.207	0.456	/

Evaluations for Simultaneous SAR, Mobile Hot Spot Positions					
Test Position	Body-Back (1.0cm)	Body-Left (1.0cm)	Body-Right (1.0cm)	Body-Bottom (1.0cm)	Body-Top (1.0cm)
Mode	Stand Alone 1-g SAR (W/Kg)				
GPRS 850	1.273	0.894	0.768	0.395	/
GPRS 1900	0.189	0.080	0.076	0.159	/
WCDMA 850	0.543	0.363	0.409	0.184	/
WCDMA 1900	0.556	0.245	0.191	0.446	/
LTE Band 2	0.753	0.274	0.315	0.571	/
LTE Band 4	0.528	0.169	0.146	0.395	/
Wi-Fi	0.174	0.174	0.174	0.174	0.174
	∑ 1-g SAR(W/Kg)				
GPRS 850 + Wi-Fi	1.447	1.068	0.942	0.569	/
GPRS 1900 + Wi-Fi	0.363	0.254	0.250	0.333	/
WCDMA 850 + Wi-Fi	0.717	0.537	0.583	0.358	/
WCDMA 1900+ Wi-Fi	0.730	0.419	0.365	0.620	/
LTE Band 2+ Wi-Fi	0.927	0.448	0.489	0.745	/
LTE Band 4+ Wi-Fi	0.702	0.343	0.320	0.569	/

Note:

If the sum of the 1g SAR measured for the simultaneously transmitting antennas is less than the SAR limit, SAR measurement for simultaneous transmission is not required.

SAR Plots (Summary of the Highest SAR Values)

Test Laboratory: Bay Area Compliance Lab Corp. (Shenzhen)

Left Head Cheek (836.6 MHz Middle Channel)

Measurement Data

Test mode : GSM
 Crest Factor : 8
 Scan Type : Complete
 Area Scan : 11x8x1: Measurement x=10mm, y=10mm, z=4mm
 Zoom Scan : 7x7x7: Measurement x=5mm, y=5mm, z=5mm
 Power Drift-Start : 0.156 W/kg
 Power Drift-Finish : 0.153 W/kg
 Power Drift (%) : -1.981

Tissue Data

Type : Head
 Frequency : 836.6 MHz
 Epsilon : 41.08 F/m
 Sigma : 0.92 S/m
 Density : 1000.00 kg/cu. m

Probe Data

Serial No. : 500-00283
 Frequency Band : 835
 Duty Cycle Factor : 8
 Conversion Factor : 5.9
 Probe Sensitivity : 1.20 1.20 1.20 $\mu\text{V}/(\text{V}/\text{m})^2$
 Compression Point : 95.00 mV
 Offset : 1.56 mm

1 gram SAR value : 0.746 W/kg
 10 gram SAR value : 0.557 W/kg
 Area Scan Peak SAR : 0.766 W/kg
 Zoom Scan Peak SAR : 1.119 W/kg

Plot 1#

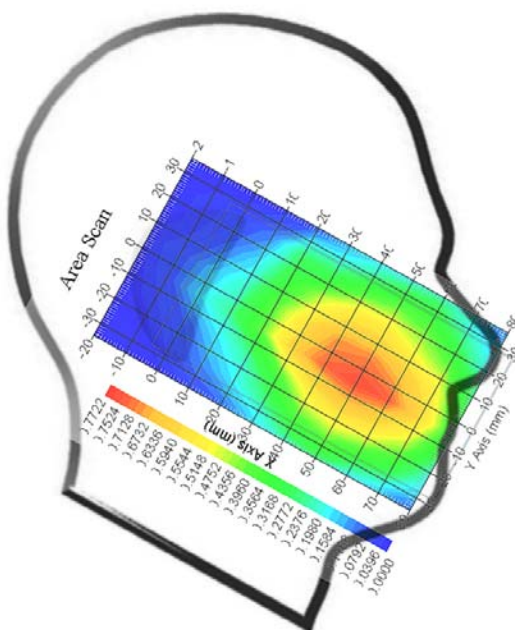

Test Laboratory: Bay Area Compliance Lab Corp. (Shenzhen)

Left Head Cheek(1880 MHz Middle Channel)

Measurement Data

Test mode : GSM
 Crest Factor : 8
 Scan Type : Complete
 Area Scan : 11x8x1 : Measurement x=10mm, y=10mm, z=4mm
 Zoom Scan : 7x7x7 : Measurement x=5mm, y=5mm, z=5mm
 Power Drift-Start : 0.003 W/kg
 Power Drift-Finish : 0.003 W/kg
 Power Drift (%) : 2.287

Tissue Data

Type : Head
 Frequency : 1880 MHz
 Epsilon : 39.70 F/m
 Sigma : 1.39 S/m
 Density : 1000.00 kg/cu. M

Probe Data

Serial No. : 500-00283
 Frequency Band : 1900
 Duty Cycle Factor : 8
 Conversion Factor : 4.8
 Probe Sensitivity : 1.20 1.20 1.20 $\mu\text{V}/(\text{V}/\text{m})^2$
 Compression Point : 95.00 mV
 Offset : 1.56 mm

1 gram SAR value : 0.118 W/kg
 10 gram SAR value : 0.083 W/kg
 Area Scan Peak SAR : 0.132 W/kg
 Zoom Scan Peak SAR : 0.207 W/kg

Plot 2#

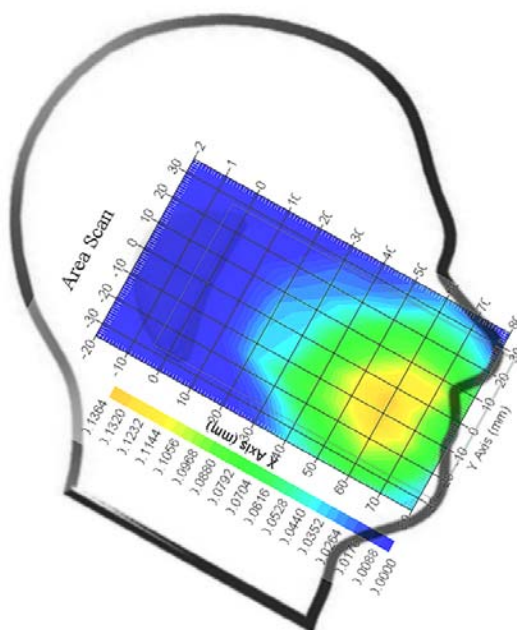

Test Laboratory: Bay Area Compliance Lab Corp. (Shenzhen)

WCDMA850; Right Head Cheek (836.6 MHz Middle Channel)

Measurement Data

Test mode : RMC
 Crest Factor : 1
 Scan Type : Complete
 Area Scan : 11x8x1: Measurement x=10mm, y=10mm, z=4mm
 Zoom Scan : 7x7x7: Measurement x=5mm, y=5mm, z=5mm
 Power Drift-Start : 0.038 W/kg
 Power Drift-Finish : 0.038 W/kg
 Power Drift (%) : 1.177

Tissue Data

Type : Head
 Frequency : 836.6 MHz
 Epsilon : 41.08 F/m
 Sigma : 0.92 S/m
 Density : 1000.00 kg/cu. m

Probe Data

Serial No. : 500-00283
 Frequency Band : 835
 Duty Cycle Factor : 1
 Conversion Factor : 5.9
 Probe Sensitivity : 1.20 1.20 1.20 $\mu\text{V}/(\text{V}/\text{m})^2$
 Compression Point : 95.00 mV
 Offset : 1.56 mm

1 gram SAR value : 0.338 W/kg
 10 gram SAR value : 0.217 W/kg
 Area Scan Peak SAR : 0.359 W/kg
 Zoom Scan Peak SAR : 0.463 W/kg

Plot 3#

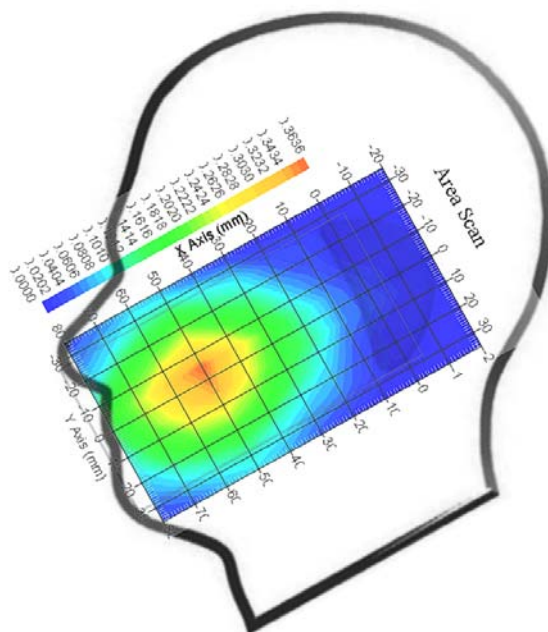

Test Laboratory: Bay Area Compliance Lab Corp. (Shenzhen)

WCDMA 1900; Left Head Cheek (1880 MHz Middle Channel)

Measurement Data

Test mode : RMC
 Crest Factor : 1
 Scan Type : Complete
 Area Scan : 11x9x1: Measurement x=10mm, y=10mm, z=4mm
 Zoom Scan : 7x7x7: Measurement x=5mm, y=5mm, z=5mm
 Power Drift-Start : 0.007 W/kg
 Power Drift-Finish : 0.007 W/kg
 Power Drift (%) : -1.680

Tissue Data

Type : Head
 Frequency : 1880 MHz
 Epsilon : 39.70 F/m
 Sigma : 1.39 S/m
 Density : 1000.00 kg/cu. m

Probe Data

Serial No. : 500-00283
 Frequency Band : 1900
 Duty Cycle Factor : 1
 Conversion Factor : 4.8
 Probe Sensitivity : 1.20 1.20 1.20 $\mu\text{V}/(\text{V}/\text{m})^2$
 Compression Point : 95.00 mV
 Offset : 1.56 mm

1 gram SAR value : 0.361 W/kg
 10 gram SAR value : 0.226 W/kg
 Area Scan Peak SAR : 0.390 W/kg
 Zoom Scan Peak SAR : 0.644 W/kg

Plot 4#

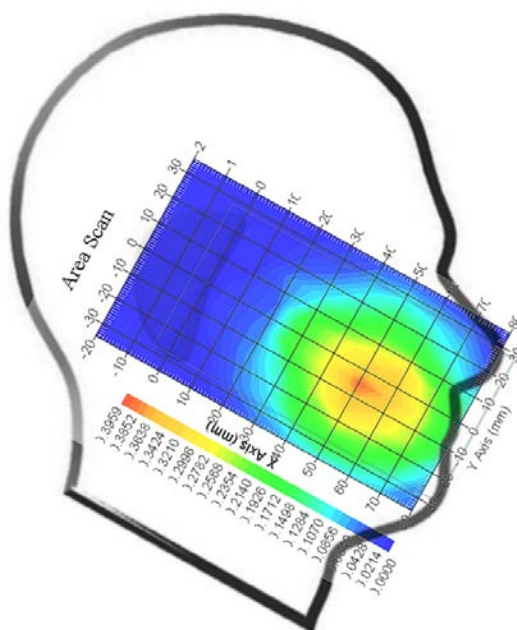

Test Laboratory: Bay Area Compliance Lab Corp. (Shenzhen)

LTE FDD Band2; Right-Head-Cheek (1900 MHz High Channel);

Measurement Data

Test mode : RB1
 Crest Factor : 1
 Scan Type : Complete
 Area Scan : 8x11x1 : Measurement x=10mm, y=10mm, z=4mm
 Zoom Scan : 7x7x7 : Measurement x=5mm, y=5mm, z=5mm
 Power Drift-Start : 0.016 W/kg
 Power Drift-Finish : 0.016 W/kg
 Power Drift (%) : -0.946

Tissue Data

Type : Head
 Frequency : 1900 MHz
 Epsilon : 39.56 F/m
 Sigma : 1.40 S/m
 Density : 1000.00 kg/cu. m

Probe Data

Serial No. : 500-00283
 Frequency Band : 1900
 Duty Cycle Factor : 1
 Conversion Factor : 4.8
 Probe Sensitivity : 1.20 1.20 1.20 $\mu\text{V}/(\text{V}/\text{m})^2$
 Compression Point : 95.00 mV
 Offset : 1.56 mm

1 gram SAR value : 0.491 W/kg
 10 gram SAR value : 0.292 W/kg
 Area Scan Peak SAR : 0.513 W/kg
 Zoom Scan Peak SAR : 0.827 W/kg

Plot 5#

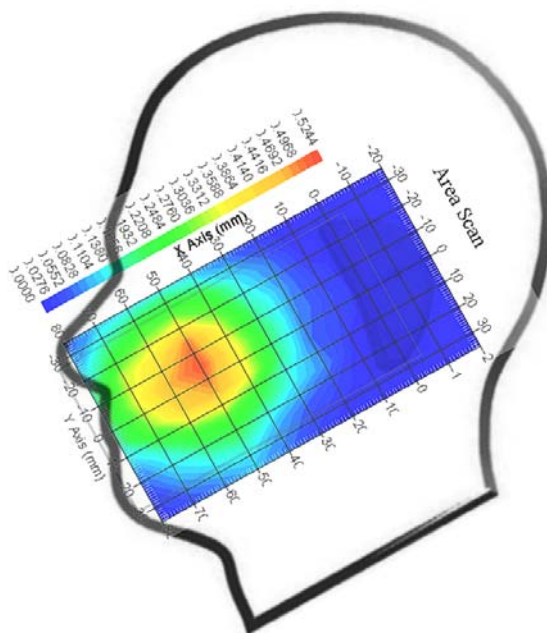

Test Laboratory: Bay Area Compliance Lab Corp. (Shenzhen)

LTE FDD Band4; Left-Head-Cheek (1720 MHz Low Channel);

Measurement Data

Test mode : RB1
 Crest Factor : 1
 Scan Type : Complete
 Area Scan : 8x11x1 : Measurement x=10mm, y=10mm, z=4mm
 Zoom Scan : 7x7x7 : Measurement x=5mm, y=5mm, z=5mm
 Power Drift-Start : 0.003 W/kg
 Power Drift-Finish : 0.003 W/kg
 Power Drift (%) : -2.714

Tissue Data

Type : Head
 Frequency : 1720 MHz
 Epsilon : 39.21 F/m
 Sigma : 1.36 S/m
 Density : 1000.00 kg/cu. m

Probe Data

Serial No. : 500-00283
 Frequency Band : 1750
 Duty Cycle Factor : 1
 Conversion Factor : 5.4
 Probe Sensitivity : 1.20 1.20 1.20 $\mu\text{V}/(\text{V}/\text{m})^2$
 Compression Point : 95.00 mV
 Offset : 1.56 mm

1 gram SAR value : 0.338 W/kg
 10 gram SAR value : 0.217 W/kg
 Area Scan Peak SAR : 0.365 W/kg
 Zoom Scan Peak SAR : 0.555 W/kg

Plot 6#

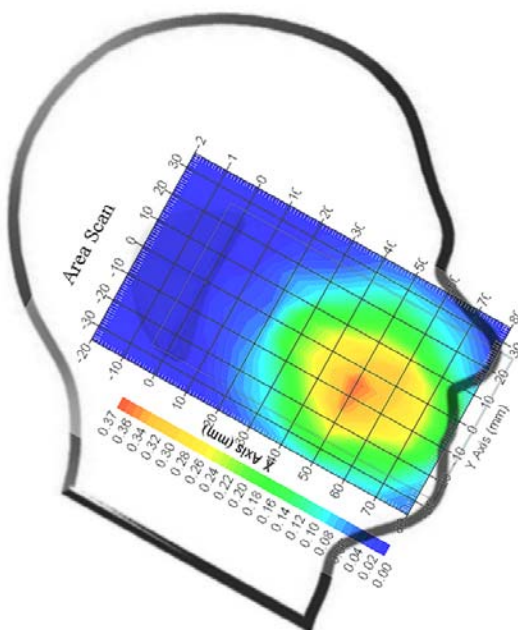

Test Laboratory: Bay Area Compliance Lab Corp. (Shenzhen)

Body-worn-Back (836.6 MHz Middle Channel)

Measurement Data

Test mode : GPRS
 Crest Factor : 2
 Scan Type : Complete
 Area Scan : 8x11x1 : Measurement x=10mm, y=10mm, z=4mm
 Zoom Scan : 7x7x7 : Measurement x=5mm, y=5mm, z=5mm
 Power Drift-Start : 1.026 W/kg
 Power Drift-Finish : 1.034 W/kg
 Power Drift (%) : 0.785

Tissue Data

Type : Body
 Frequency : 836.6 MHz
 Epsilon : 53.80 F/m
 Sigma : 0.96 S/m
 Density : 1000.00 kg/cu. m

Probe Data

Serial No. : 500-00283
 Frequency Band : 835
 Duty Cycle Factor : 2
 Conversion Factor : 5.9
 Probe Sensitivity : 1.20 1.20 1.20 $\mu\text{V}/(\text{V}/\text{m})^2$
 Compression Point : 95.00 mV
 Offset : 1.56 mm

1 gram SAR value : 1.253 W/kg
 10 gram SAR value : 0.980 W/kg
 Area Scan Peak SAR : 1.262 W/kg
 Zoom Scan Peak SAR : 1.776 W/kg

Plot 7#

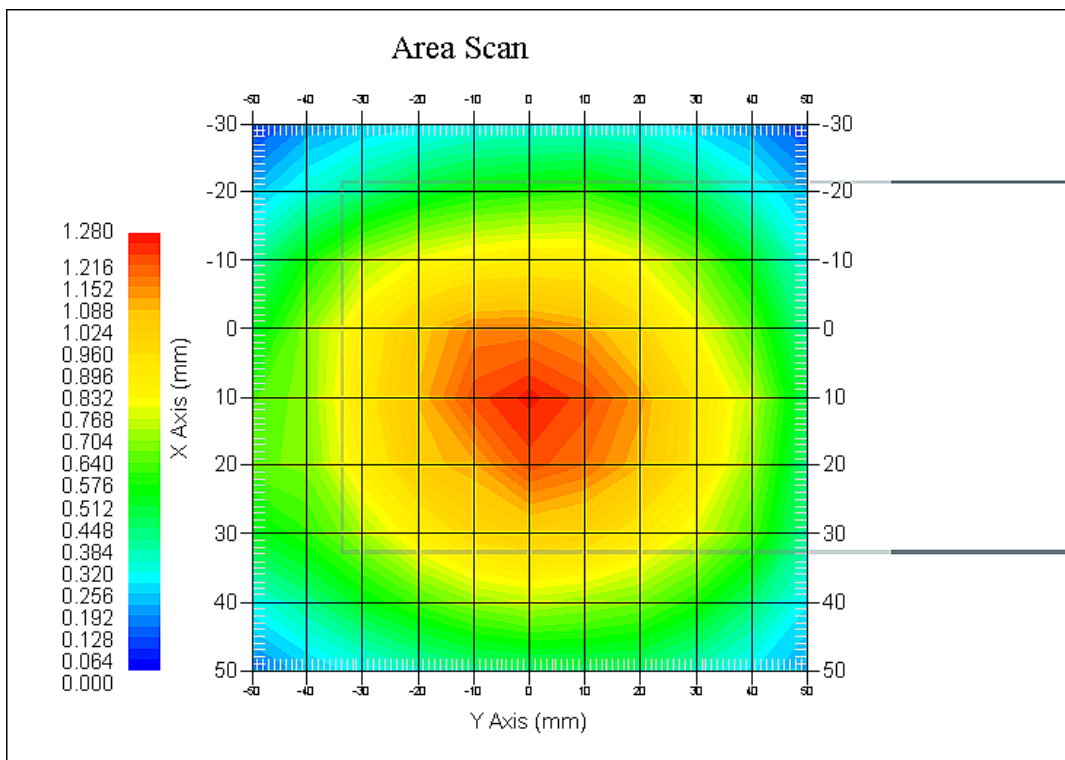

Test Laboratory: Bay Area Compliance Lab Corp. (Shenzhen)

Body-worn-Back (1880 MHz Middle Channel)

Measurement Data

Test mode : GPRS
 Crest Factor : 2
 Scan Type : Complete
 Area Scan : 8x11x1 : Measurement x=10mm, y=10mm, z=4mm
 Zoom Scan : 7x7x7 : Measurement x=5mm, y=5mm, z=5mm
 Power Drift-Start : 0.104 W/kg
 Power Drift-Finish : 0.107 W/kg
 Power Drift (%) : 2.988

Tissue Data

Type : Body
 Frequency : 1880 MHz
 Epsilon : 51.88 F/m
 Sigma : 1.52 S/m
 Density : 1000.00 kg/cu. m

Probe Data

Serial No. : 500-00283
 Frequency Band : 1900
 Duty Cycle Factor : 2
 Conversion Factor : 4.5
 Probe Sensitivity : 1.20 1.20 1.20 $\mu\text{V}/(\text{V}/\text{m})^2$
 Compression Point : 95.00 mV
 Offset : 1.56 mm

1 gram SAR value : 0.182 W/kg
 10 gram SAR value : 0.125 W/kg
 Area Scan Peak SAR : 0.223 W/kg
 Zoom Scan Peak SAR : 0.380 W/kg

Plot 8#

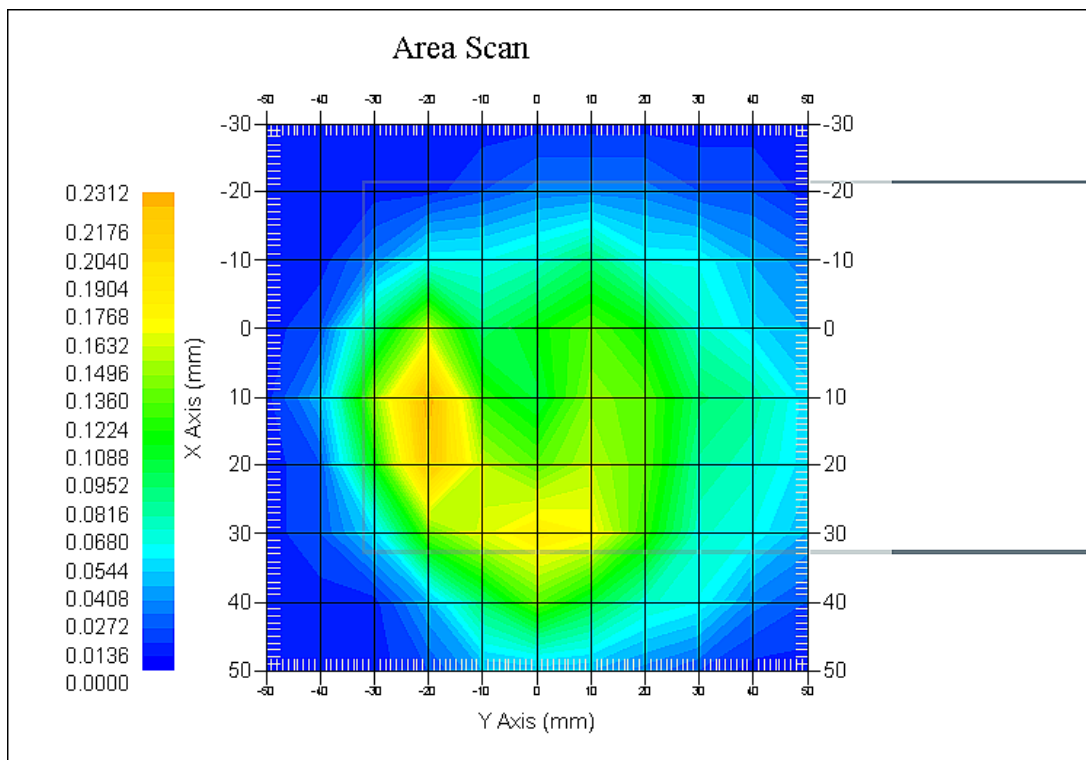

Test Laboratory: Bay Area Compliance Lab Corp. (Shenzhen)

WCDMA850; Body-Worn-Back (836.6 MHz Middle Channel)

Measurement Data

Test mode : RMC
 Crest Factor : 1
 Scan Type : Complete
 Area Scan : 11x8x1: Measurement x=10mm, y=10mm, z=4mm
 Zoom Scan : 7x7x7: Measurement x=5mm, y=5mm, z=5mm
 Power Drift-Start : 0.455 W/kg
 Power Drift-Finish : 0.451 W/kg
 Power Drift (%) : -0.892

Tissue Data

Type : Body
 Frequency : 836.6 MHz
 Epsilon : 53.80 F/m
 Sigma : 0.96 S/m
 Density : 1000.00 kg/cu. m

Probe Data

Serial No. : 500-00283
 Frequency Band : 835
 Duty Cycle Factor : 1
 Conversion Factor : 5.9
 Probe Sensitivity : 1.20 1.20 1.20 $\mu\text{V}/(\text{V}/\text{m})^2$
 Compression Point : 95.00 mV
 Offset : 1.56 mm

1 gram SAR value : 0.503 W/kg
 10 gram SAR value : 0.425 W/kg
 Area Scan Peak SAR : 0.511 W/kg
 Zoom Scan Peak SAR : 0.725 W/kg

Plot 9#

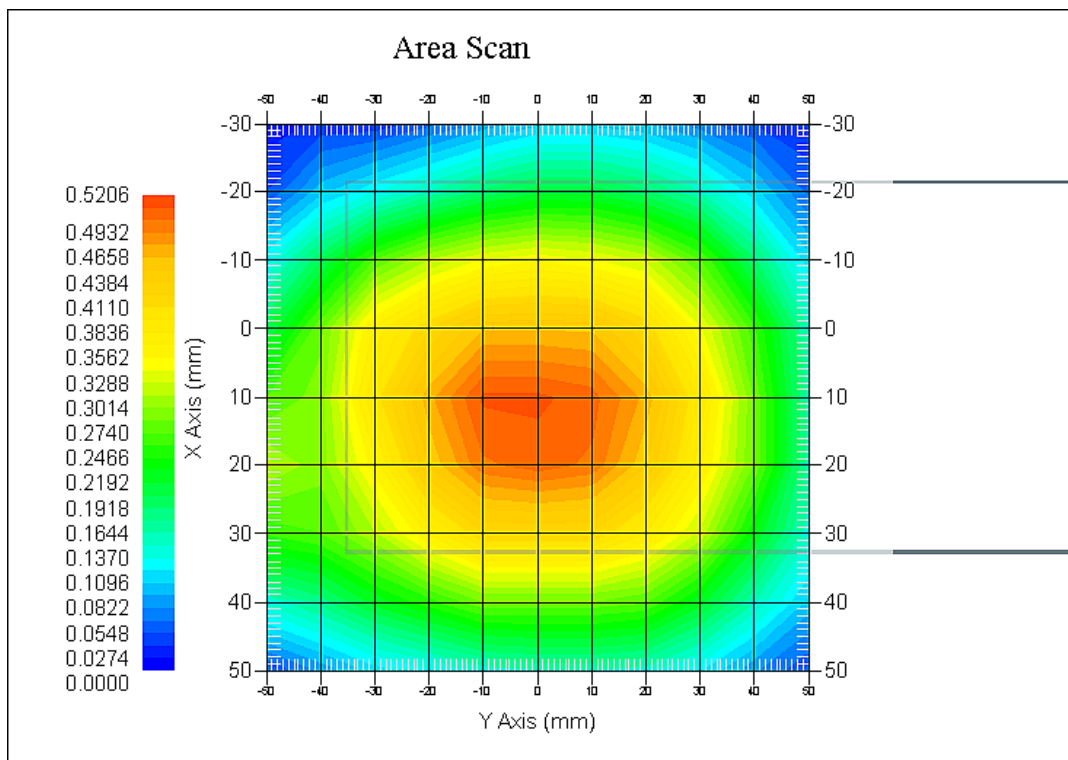

Test Laboratory: Bay Area Compliance Lab Corp. (Shenzhen)

WCDMA1900; Body-Worn-Back (1880 MHz Middle Channel)

Measurement Data

Test mode : RMC
 Crest Factor : 1
 Scan Type : Complete
 Area Scan : 11x9x1: Measurement x=10mm, y=10mm, z=4mm
 Zoom Scan : 7x7x7: Measurement x=5mm, y=5mm, z=5mm
 Power Drift-Start : 0.263 W/kg
 Power Drift-Finish : 0.266 W/kg
 Power Drift (%) : 1.153

Tissue Data

Type : Body
 Frequency : 1880.0 MHz
 Epsilon : 51.88 F/m
 Sigma : 1.52 S/m
 Density : 1000.00 kg/cu. m

Probe Data

Serial No. : 500-00283
 Frequency Band : 1900
 Duty Cycle Factor : 1
 Conversion Factor : 4.8
 Probe Sensitivity : 1.20 1.20 1.20 $\mu\text{V}/(\text{V}/\text{m})^2$
 Compression Point : 95.00 mV
 Offset : 1.56 mm

1 gram SAR value : 0.542 W/kg
 10 gram SAR value : 0.333 W/kg
 Area Scan Peak SAR : 0.610 W/kg
 Zoom Scan Peak SAR : 1.086 W/kg

Plot 10#

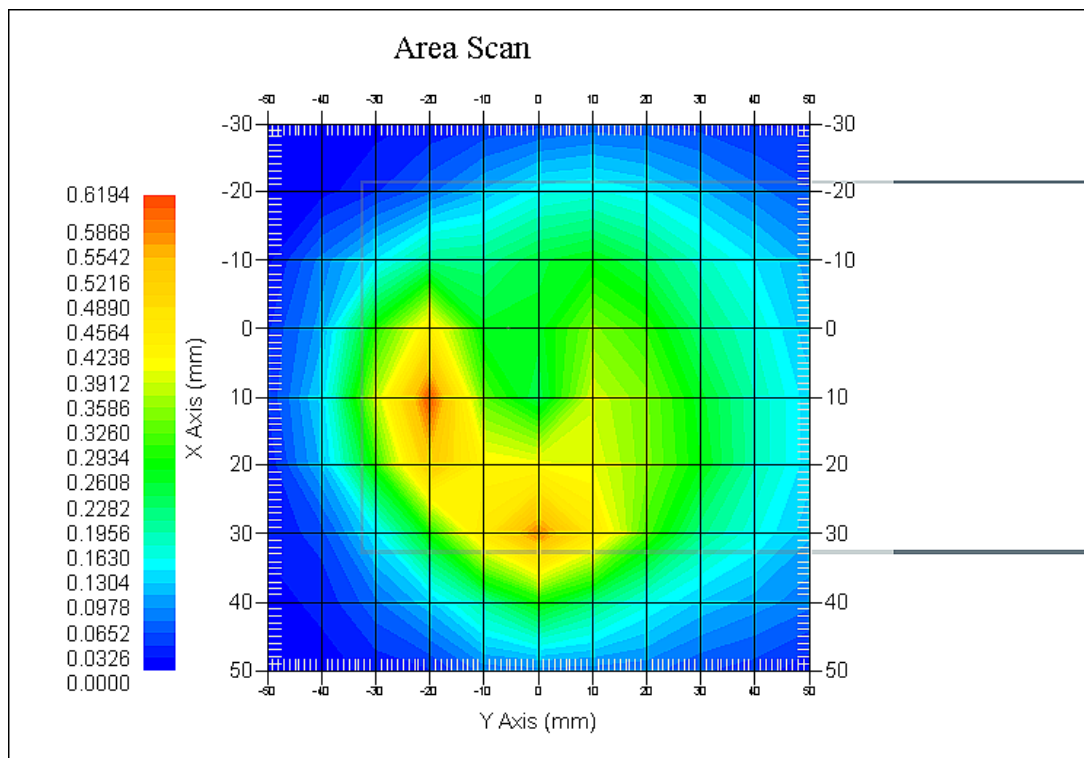

Test Laboratory: Bay Area Compliance Lab Corp. (Shenzhen)

LTE FDD Band2; Body-Worn-Back (1900 MHz High Channel);

Measurement Data

Test mode : 1RB
 Crest Factor : 1
 Scan Type : Complete
 Area Scan : 8x11x1 : Measurement x=10mm, y=10mm, z=4mm
 Zoom Scan : 7x7x7 : Measurement x=5mm, y=5mm, z=5mm
 Power Drift-Start : 0.501 W/kg
 Power Drift-Finish : 0.505 W/kg
 Power Drift (%) : 0.797

Tissue Data

Type : Body
 Frequency : 1900 MHz
 Epsilon : 51.88 F/m
 Sigma : 1.53 S/m
 Density : 1000.00 kg/cu. m

Probe Data

Serial No. : 500-00283
 Frequency Band : 1900
 Duty Cycle Factor : 1
 Conversion Factor : 4.5
 Probe Sensitivity : 1.20 1.20 1.20 $\mu\text{V}/(\text{V}/\text{m})^2$
 Compression Point : 95.00 mV
 Offset : 1.56 mm

1 gram SAR value : 0.750 W/kg
 10 gram SAR value : 0.454 W/kg
 Area Scan Peak SAR : 0.803 W/kg
 Zoom Scan Peak SAR : 1.388 W/kg

Plot 11#

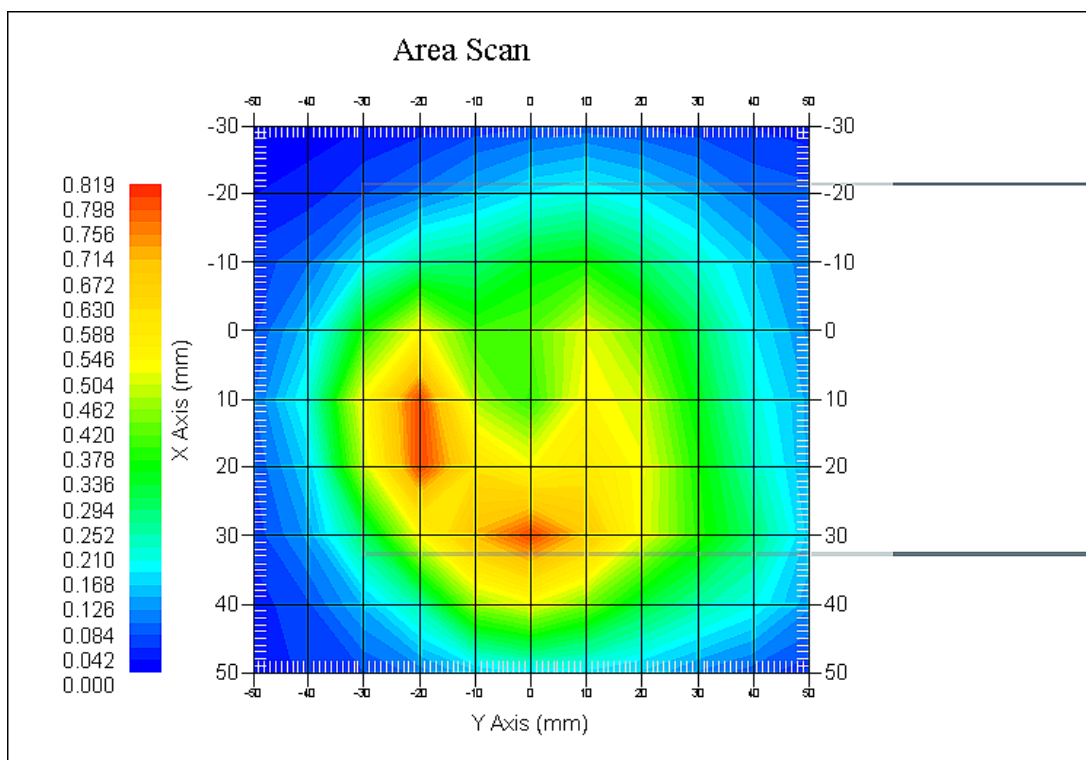

Test Laboratory: Bay Area Compliance Lab Corp. (Shenzhen)

LTE FDD Band4; Body-Worn-Back (1720 MHz Low Channel);

Measurement Data

Test mode : 1RB
 Crest Factor : 1
 Scan Type : Complete
 Area Scan : 8x11x1 : Measurement x=10mm, y=10mm, z=4mm
 Zoom Scan : 7x7x7 : Measurement x=5mm, y=5mm, z=5mm
 Power Drift-Start : 0.331 W/kg
 Power Drift-Finish : 0.327 W/kg
 Power Drift (%) : -1.228

Tissue Data

Type : Body
 Frequency : 1720 MHz
 Epsilon : 51.93 F/m
 Sigma : 1.49 S/m
 Density : 1000.00 kg/cu. m

Probe Data

Serial No. : 500-00283
 Frequency Band : 1750
 Duty Cycle Factor : 1
 Conversion Factor : 5.3
 Probe Sensitivity : 1.20 1.20 1.20 $\mu\text{V}/(\text{V}/\text{m})^2$
 Compression Point : 95.00 mV
 Offset : 1.56 mm

1 gram SAR value : 0.520 W/kg
 10 gram SAR value : 0.318 W/kg
 Area Scan Peak SAR : 0.576 W/kg
 Zoom Scan Peak SAR : 0.839 W/kg

Plot 12#

