

FCC - TEST REPORT

Report Number : **68.910.18.0058.01** Date of Issue: December 28, 2018

Model : **CM-11**

Product Type : 1 Channel Hand remote

Applicant : Coulisse B.V.

Address : Vonderweg 48, 7468 DC Enter, THE NETHERLANDS

Production Facility : Ningbo Dooya Mechanic & Electronic Technology Co., Ltd.

Address : No.168 Shengguang Road, Luotuo, Zhenhai 315202 Ningbo,
Zhejiang province, PEOPLE'S REPUBLIC OF CHINA

Test Result : **Positive** **Negative**

Total pages including Appendices : 15

TÜV SÜD Certification and Testing (China) Co., Ltd. Shenzhen Branch is a subcontractor to TÜV SÜD Product Service GmbH according to the principles outlined in ISO 17025.

TÜV SÜD Certification and Testing (China) Co., Ltd. Shenzhen Branch reports apply only to the specific samples tested under stated test conditions. Construction of the actual test samples has been documented. It is the manufacturer's responsibility to assure that additional production units of this model are manufactured with identical electrical and mechanical components. The manufacturer/importer is responsible to the Competent Authorities in Europe for any modifications made to the production units which result in non-compliance to the relevant regulations. TÜV SÜD Certification and Testing (China) Co., Ltd. Shenzhen Branch shall have no liability for any deductions, inferences or generalizations drawn by the client or others from TÜV SÜD Certification and Testing (China) Co., Ltd. Shenzhen Branch issued reports.

This report is the confidential property of the client. As a mutual protection to our clients, the public and ourselves, extracts from the test report shall not be reproduced except in full without our written approval



1 Table of Contents

1	Table of Contents	2
2	Details about the Test Laboratory.....	3
3	Description of the Equipment Under Test.....	4
4	Summary of Test Standards	5
5	Summary of Test Results	6
6	General Remarks	7
7	Systems test configuration	8
8	Test Setups	9
9	Test Methodology.....	10
9.1	Radiated Emission.....	10
9.2	Bandwidth Measurement	12
9.3	Deactivation Time	13
10	Test Equipment List.....	14
11	System Measurement Uncertainty.....	15



2 Details about the Test Laboratory

Details about the Test Laboratory

Test Site 1

Company name: TÜV SÜD Certification and Testing (China) Co., Ltd. Shenzhen Branch
Building 12&13, Zhiheng Wisdomland Business Park,
Nantou Checkpoint Road 2, Nanshan District,
Shenzhen City, 518052,
P. R. China

FCC Registration Number: 514049

Telephone: 86 755 8828 6998

Fax: 86 755 8828 5299

3 Description of the Equipment Under Test

Product: 1 Channel Hand remote

Model no.: CM-11

FCC ID: ZY4CM11

Rating: 3VDC (Supplied by CR2430 battery)

RF Transmission Frequency: 433.925MHz

Modulation: FSK

Antenna Type: PCB Antenna

Antenna Gain: 1.0dBi

Description of the EUT: The Equipment Under Test (EUT) is a 1 Channel Hand remote operated at 433.925MHz



4 Summary of Test Standards

Test Standards	
FCC Part 15 Subpart C 10-1-2017 Edition	PART 15 - RADIO FREQUENCY DEVICES Subpart C - Intentional Radiators

All the test methods were according to ANSI C63.10.



5 Summary of Test Results

Technical Requirements				
FCC Part 15 Subpart C				
Test Condition		Pages	Test Site	Test Result
§15.207	Conducted emission AC power port	N/A	N/A	Not Applicable
§15.205, §15.209, 15.35 (c)§15.231 (b)	Radiated Emission, 30MHz to 4.5GHz	10	Site 1	Pass
§15.231(c)	Bandwidth Measurement	12	Site 1	Pass
§15.231(a) (1)	Deactivation Time	13	Site 1	Pass

Note 1: N/A=Not Applicable.

Note 2: The EUT uses an PCB Antenna, which gain is 1.0dBi. In accordance to §15.203, It is considered sufficiently to comply with the provisions of this section.

6 General Remarks

Remarks

This submittal(s) (test report) is intended for FCC ID: ZY4CM11 complies with Section 15.209, 15.231 of the FCC Part 15.

SUMMARY:

All tests according to the regulations cited on page 5 were

n - Performed

o - **Not** Performed

The Equipment Under Test

n - **Fulfills** the general approval requirements.

o - **Does not** fulfill the general approval requirements.

Sample Received Date: August 31, 2018

Testing Start Date: August 31, 2018

Testing End Date: September 17, 2018

TÜV SÜD Certification and Testing (China) Co., Ltd. Shenzhen Branch

Reviewed by:



Phoebe Hu
EMC Section Manager

Prepared by:



Mark Chen
EMC Project Engineer

Tested by:



Carry Cai
EMC Test Engineer



7 Systems test configuration

Auxiliary Equipment Used during Test:

DESCRIPTION	MANUFACTURER	MODEL NO.(SHIELD)	S/N(LENGTH)
--	--	--	--

8 Test Setups

7.1 Radiated test setups

Below 1GHz

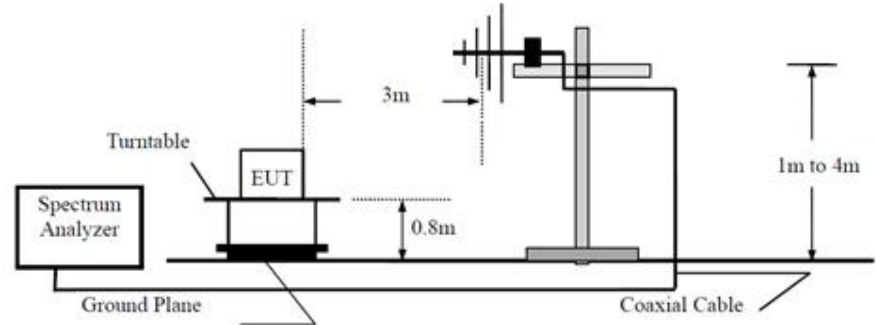

Above 1GHz

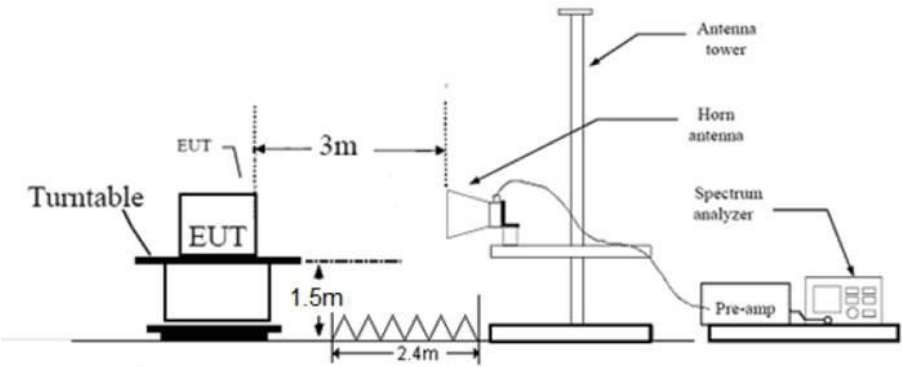

7.2 Conducted RF test setups

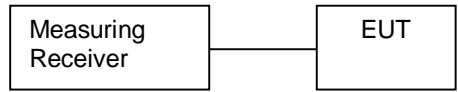

9 Test Methodology

9.1 Radiated Emission

Test Method

1: The EUT was placed on a turn table which is 1.5m above ground plane for above 1GHz and 0.8m above ground for below 1GHz at 3 meter chamber room for test. The table was rotated 360 degrees to determine the position of the highest radiation.

2: The EUT was set 3 meters away from the interference – receiving antenna, which was mounted on the top of a variable – height antenna tower.

3: The height of antenna is varied from one meter to four meters above the ground to determine the maximum value of the field strength. Both horizontal and vertical polarizations of the antenna are set to make the measurement.

4: For each suspected emission, the EUT was arranged to its worst case and then the antenna was tuned to heights from 1 meter to 4 meters and the rotatable table was turned from 0 degrees to 360 degrees to find the maximum reading.

5: Use the following spectrum analyzer settings According to C63.10:

For Above 1GHz

Span = wide enough to capture the peak level of the in-band emission and all spurious
 RBW = 1MHz, VBW \geq RBW for peak measurement and VBW = 10Hz for average measurement, Sweep = auto, Detector function = peak, Trace = max hold.

For Below 1GHz

Use the following spectrum analyzer settings:

Span = wide enough to capture the peak level of the in-band emission and all spurious
 RBW = 100 KHz, VBW \geq RBW for peak measurement, Sweep = auto, Detector function = peak, Trace = max hold.

Limit

According to §15.231 (b), the field strength of emissions from intentional radiators operated under this section shall not exceed the following:

Fundamental frequency (MHz)	Field Strength of Fundamental (Microvolts /meter)	Field Strength of spurious emissions ((Microvolts /meter)
40.66-40.70	2,250	225
70-130	1,250	125
130-174	1,250 to 3,370 *	125 to 375 *
174-260	3,750	375
260-470 \checkmark	3,750 to 12,500*	375 to 1,250*
Above 470	12,500	1,250



Spurious radiated emissions for transmitter

According to C63.10, if the peak (or quasi-peak) measured value complies with the average limit, it is unnecessary to perform an average measurement, so AV emission value did not show in below table if the peak value complies with average limit.

Radiated Emissions								
Value	Emissions Frequency MHz	E-Field Polarity	Field at 3m dBµV/m	Average Factor dB	Net Field at 3m dBµV/m	Limit dBµV/m	Margin	Emission Type
Below 1GHz								
PK	433.925	H	59.62	0.00	59.62	100.83	41.21	Fundamental
AV	433.925	H	59.62	0.00	59.62	80.83	21.21	Fundamental
PK	433.925	V	63.12	0.00	63.12	100.83	37.71	Fundamental
AV	433.925	V	63.12	0.00	63.12	80.83	17.71	Fundamental
PK	867.910	H	45.99	0.00	45.99	80.83	34.84	Spurious
AV	867.910	H	45.99	0.00	45.99	60.83	14.84	Spurious
PK	867.910	V	36.12	0.00	36.12	80.83	44.71	Spurious
AV	867.910	V	36.12	0.00	36.12	60.83	24.71	Spurious
Above 1GHz								
PK	1239.3	H	49.35	0.00	49.35	74	24.65	Spurious
AV	1239.3	H	49.35	0	49.35	54	4.65	Spurious
PK	1752.9	V	35.67	0.00	35.67	74	38.33	Spurious
AV	1752.9	V	35.67	0	35.67	54	18.33	Spurious

Remark:

1: AV Emission Level= PK Emission Level+20log(dutycycle)

2: Data of measurement within this frequency range shown “/” in the table above means the reading of emissions are attenuated more than 20db below the permissible limits or the field strength is too small to be measured.

3: “*” means the emission(s) appear within the restrict bands shall follow the requirement of section 15.205.

Duty Cycle = 100(ms)/100 (ms) = 100%

Duty Cycle Factor = 20log (Duty Cycle) = 0

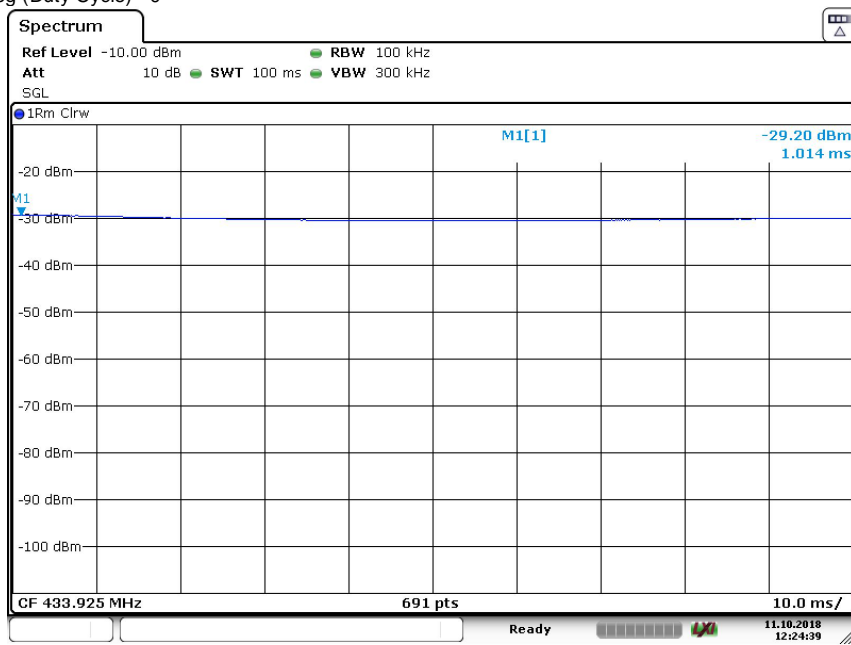

Date: 11.OCT.2018 12:24:40

9.2 Bandwidth Measurement

Test Method

1. Check the calibration of the measuring instrument using either an internal calibrator or a known signal from an external generator.
2. Position the EUT without connection to measurement instrument. Turn on the EUT and connect it to measurement instrument. Then set it to any one convenient frequency within its operating range. Set a reference level on the measuring instrument equal to the highest peak value.
3. Measure the frequency difference of two frequencies that were attenuated 20 dB from the reference level. Record the frequency difference as the emission bandwidth.
4. Repeat above procedures until all frequencies measured were complete.

Limit

The bandwidth of the emission shall be no wider than 0.25% of the center frequency for devices operating above 70MHz and below 900MHz. For devices operating above 900MHz, the emission shall be no wider than 0.5% of the center frequency. Bandwidth is determined at the points 20dB down from the modulated carrier.

The limit for the EUT = 0.25% * 433.925 MHz = 1084 kHz

Test Result

Channel	20dB Bandwidth (KHz)	99% bandwidth (KHz)	Limit (KHz)
1	84.23KHz	87.99KHz	1085KHz

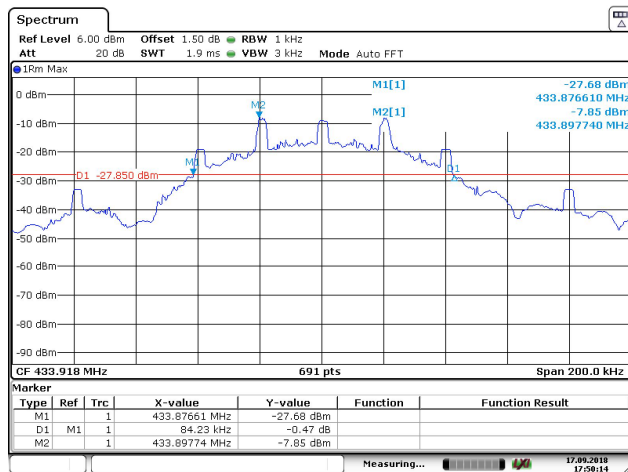

Date: 17.SEP.2018 17:50:15

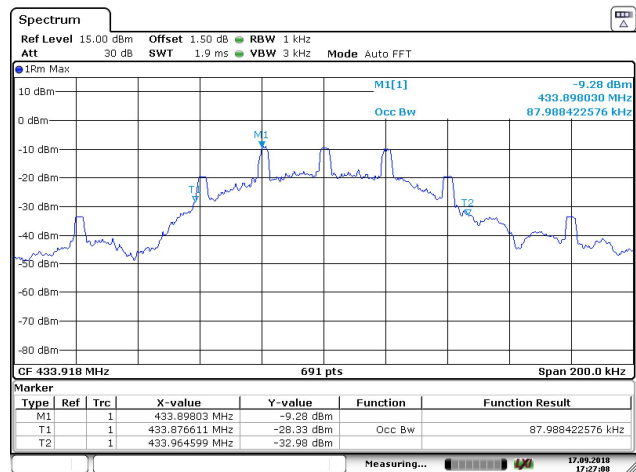

Date: 17.SEP.2018 17:27:08

9.3 Deactivation Time

Test Method

1. Place the EUT in the chamber and set it in transmitting mode.
2. Set center frequency of spectrum analyzer=operating frequency.
3. Set the spectrum analyzer as RBW=120 KHz, VBW=1MHz, Span=0Hz.
4. Repeat above procedures until all frequency measured was complete.

Limit

According to FCC Part 15.231 (a), the transmitter shall be complied the following requirements:

- (√) (1) A manually operated transmitter shall employ a switch that will automatically deactivate the transmitter within not more than 5 seconds of being released.
- (2) A transmitter activated automatically shall cease transmission within 5 seconds after activation.
- (3) Periodic transmissions at regular predetermined intervals are not permitted. However, polling or supervision transmissions, including data, to determine system integrity of transmitters used in security or safety applications are allowed if the total duration of transmissions does not exceed more than two seconds per hour for each transmitter. There is no limit on the number of individual transmissions, provided the total transmission time does not exceed two seconds per hour.

Test Result

Channel	Frequency	Deactivation Time	Result
1	433.925MHz	443.48ms	Pass

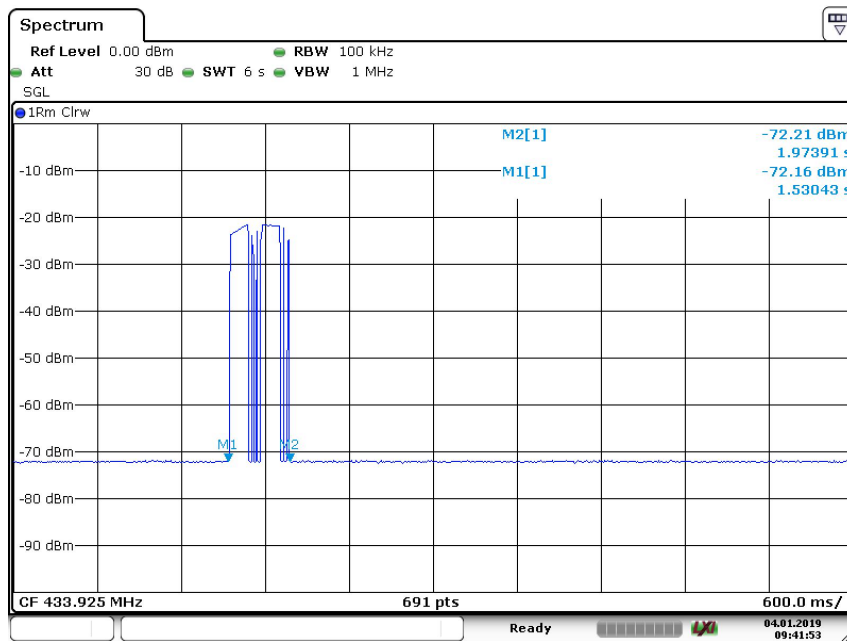

Date: 4.JAN.2019 09:41:54

10 Test Equipment List

List of Test Instruments

	Description	Manufacturer	Model no.	Serial no.	CAL. DUE DATE
C	Signal Analyzer	Rohde & Schwarz	FSV40	101031	2019-7-6
RE	EMI Test Receiver	Rohde & Schwarz	ESR 26	101269	2019-7-6
	Trilog Super Broadband Test Antenna	Schwarzbeck	VULB 9163	707	2019-6-28
	Horn Antenna	Rohde & Schwarz	HF907	102294	2019-6-28
	Pre-amplifier	Rohde & Schwarz	SCU 18	102230	2019-7-6
	Pre-amplifier	Rohde & Schwarz	SMY01	839369/005	2019-7-6
	Signal Generator	Rohde & Schwarz	8491A	MY39264334	2019-7-6
	3m Semi-anechoic chamber	TDK	9X6X6	----	2020-7-7
Test software	Rohde & Schwarz	EMC32	Version 9.15.00	N/A	

C - Conducted RF tests

- 20dB bandwidth and 99% bandwidth
- Deactivation Time

11 System Measurement Uncertainty

For a 95% confidence level, the measurement expanded uncertainties for defined systems, in accordance with the recommendations of ISO 17025 were:

System Measurement Uncertainty

Items	Extended Uncertainty
Uncertainty for Radiated Spurious Emission 25MHz-3000MHz	Horizontal: 4.80dB; Vertical: 4.87dB;
Uncertainty for Radiated Spurious Emission 3000MHz-18000MHz	Horizontal: 4.59dB; Vertical: 4.58dB;
Uncertainty for Radiated Spurious Emission 18000MHz-40000MHz	Horizontal: 5.05dB; Vertical: 5.04dB;
Uncertainty for Conducted RF test with TS 8997	RF Power Conducted: 1.16dB Frequency test involved: 0.6×10 ⁻⁷ or 1%