



## FCC/ISED TEST REPORT

Report Number : **709502115362-00** Date of Issue: February 11, 2022

Model : CM-03-E

Product Type : Tubular motor

Applicant : Coulisse B.V.

Address : Vonderweg 48, 7468 DC Enter, THE NETHERLANDS

Production Facility : Ningbo Dooya Mechanic & Electronic Technology Co., Ltd.

Address : No.168 Shengguang Road,Luotuo,Zhenhai, Ningbo,  
: Zhejiang province, People's republic of China

Test Result :  **Positive**       **Negative**

Total pages including Appendices : 22

*TÜV SÜD Certification and Testing (China) Co., Ltd. Shanghai Branch is a subcontractor to TÜV SÜD Product Service GmbH according to the principles outlined in ISO 17025.*

*TÜV SÜD Certification and Testing (China) Co., Ltd. Shanghai Branch reports apply only to the specific samples tested under stated test conditions. Construction of the actual test samples has been documented. It is the manufacturer's responsibility to assure that additional production units of this model are manufactured with identical electrical and mechanical components. The manufacturer/importer is responsible to the Competent Authorities in Europe for any modifications made to the production units which result in non-compliance to the relevant regulations. TÜV SÜD Certification and Testing (China) Co., Ltd. Shanghai Branch shall have no liability for any deductions, inferences or generalizations drawn by the client or others from TÜV SÜD Certification and Testing (China) Co., Ltd. Shanghai Branch issued reports.*

*This report is the confidential property of the client. As a mutual protection to our clients, the public and ourselves, extracts from the test report shall not be reproduced except in full without our written approval.*



# 1 Table of Contents

1	Table of Contents .....	2
2	Details about the Test Laboratory.....	3
3	Description of the Equipment Under Test.....	4
4	Summary of Test Standards .....	6
5	Summary of Test Results .....	7
6	General Remarks .....	8
7	Systems test configuration .....	9
8	Test Setups .....	10
9	Test Methodology.....	11
9.1	Radiated Emission.....	14
9.2	Bandwidth Measurement .....	18
9.3	Deactivation Time .....	20
10	Test Equipment List.....	21
11	System Measurement Uncertainty .....	22



## 2 Details about the Test Laboratory

### Details about the Test Laboratory

#### Test Site 1

Company name: TÜV SÜD Certification and Testing (China) Co., Ltd. Shanghai Branch  
No.16 Lane, 1951 Du Hui Road,  
Shanghai 201108,  
P.R. China

Designation  
Number: CN1183

Test Firm FCC  
Registration  
Number: 820234

IC Company  
Number: 25988

CAB identifier: CN0101

Telephone: +86 21 6141 0123  
Fax: +86 21 6140 8600



### 3 Description of the Equipment Under Test

Product: Tubular motor

Model no./HVIN/PMN: CM-03-E

FCC ID: ZY4CM03E

IC: 28177-CM03E

Rating: 5VDC

RF Transmission Frequency: 433.92MHz  
2405~2480 MHz (thread)  
2402~2480 MHz (BLE 5.0)

Modulation: For 433.92MHz: 2GFSK  
For 2.4GHz Thread: OQPSK  
For 2.4GHz BLE: GFSK

Channel list:

Bluetooth Low Energy							
Ch	Fre(MHz)	Ch	Fre(MHz)	Ch	Fre(MHz)	Ch	Fre(MHz)
0	2402	10	2422	20	2442	30	2462
1	2404	11	2424	21	2444	31	2464
2	2406	12	2426	22	2446	32	2466
3	2408	13	2428	23	2448	33	2468
4	2410	14	2430	24	2450	34	2470
5	2412	15	2432	25	2452	35	2472
6	2414	16	2434	26	2454	36	2474
7	2416	17	2436	27	2456	37	2476
8	2418	18	2438	28	2458	38	2478
9	2420	19	2440	29	2460	39	2480



Thread			
Channel	Frequency	Channel	Frequency
11	2405 MHz	19	2445 MHz
12	2410 MHz	20	2450 MHz
13	2415 MHz	21	2455 MHz
14	2420 MHz	22	2460 MHz
15	2425 MHz	23	2465 MHz
16	2430 MHz	24	2470 MHz
17	2435 MHz	25	2475 MHz
18	2440 MHz	26	2480 MHz

Antenna Type: For 433.92MHz: line antenna  
 For 2.4GHz Thread and BLE: line Antenna

Antenna Gain: For 433.92MHz: -7.16dBi  
 For 2.4GHz Thread and BLE: 3.5dBi

Description of the EUT: The Equipment Under Test (EUT) is a Tubular motor which transmitted at 433.92MHz and support 2.4GHz thread and BLE5.0 (support 1Mbps and 2Mbps data rate). we tested it and listed the worst data in this report.

Test sample no.: SHA-614504-2



#### 4 Summary of Test Standards

Test Standards	
FCC Part 15 Subpart C:2020	PART 15 - RADIO FREQUENCY DEVICES Subpart C - Intentional Radiators
RSS-Gen Issue 5 April 2018	General Requirements and Information for the Certification of Radio Apparatus
RSS-210 Issue 9 August 2016	RSS-210 — Licence-exempt Radio Apparatus (All Frequency Bands): Category I Equipment

All the test methods were according to ANSI C63.10-2013.



## 5 Summary of Test Results

Technical Requirements					
FCC Part 15 Subpart C, RSS-210 Issue 10					
Test Condition			Pages	Test Site	Test Result
§15.207	RSS-GEN A8.8	Conducted emission AC power port	10-12	Shielding room	Pass
§15.205, §15.209, 15.35 (c)§15.231(b)	RSS-210 A.1.2	Radiated Emission, 9kHz to 4.5GHz	13-16	3m chamber	Pass
§15.231(c)	RSS-210 A.1.3	Bandwidth Measurement	17-18	Shield room	Pass
§15.231(a)(1)	RSS-210 A.1.1(a)	Deactivation Time	19	Shield room	Pass
§15.203	RSS-Gen 6.	Antenna requirement	--	See Note 2	Pass

Note 1: The EUT uses a line antenna which gain is -7.16dBi for 433.92MHz and 3.5dBi for 2.4GHz thread and BLE. In accordance to §15.203, It is considered sufficiently to comply with the provisions of this section.



## 6 General Remarks

### Remarks

This submittal(s) (test report) is intended for FCC ID: ZY4CM03E, IC: 28177-CM03E complies with Section 15.207, 15.205, 15.209, 15.231 of the FCC Part 15, Subpart C Rules. RSS-Gen Issue 5 and RSS-210 Issue 10.

This report is only for the 433.92MHz test report, for the 2.4GHz BLE test report please refer to 709502115326-00 and the 2.4GHz thread test report please refer to 709502115366-00.

### SUMMARY:

All tests according to the regulations cited on page 5 were

- Performed

- **Not** Performed

The Equipment Under Test

- **Fulfills** the general approval requirements.

- **Does not** fulfill the general approval requirements.

Sample Received Date: November 19, 2021

Testing Start Date: November 19, 2021

Testing End Date: December 2, 2021

TÜV SÜD Certification and Testing (China) Co., Ltd. Shanghai Branch

Reviewed by:

Prepared by:

Tested by:

Hui TONG  
EMC Section Manager

Jiayi XU  
EMC Project Engineer

Huali CHENG  
EMC Test Engineer





## 7 Systems test configuration

Auxiliary Equipment Used during Test:

DESCRIPTION	MANUFACTURER	MODEL NO.(SHIELD)	S/N(LENGTH)
Adapter	MLF	MLF-A260502000UU	--

## 8 Test Setups

### 8.1 AC Power Line Conducted Emission test setups

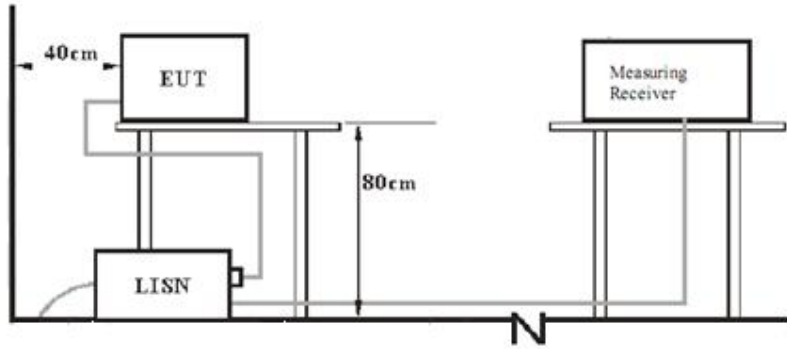

### 8.2 Radiated test setups

Below 1GHz

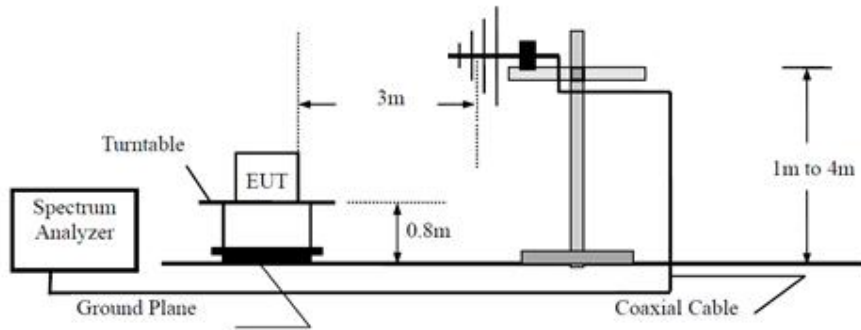

Above 1GHz

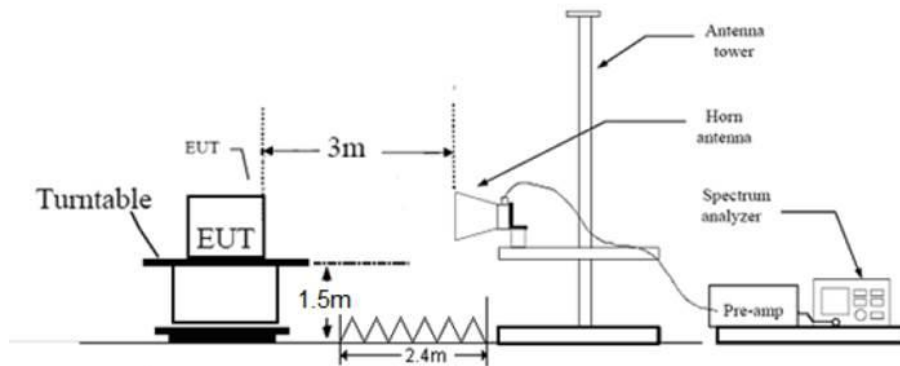



## 9 Test Methodology

### 9.1 Conducted Emission

#### Test Method

1. The EUT was placed on a table, which is 0.8m above ground plane
2. The power line of the EUT is connected to the AC mains through an Artificial Mains Network (A.M.N.).
3. Maximum procedure was performed to ensure EUT compliance
4. An EMI test receiver is used to test the emissions from both sides of AC line

#### Limit

Frequency MHz	QP Limit dB $\mu$ V	AV Limit dB $\mu$ V
0.150-0.500	66-56*	56-46*
0.500-5	56	46
5-30	60	50

Decreasing linearly with logarithm of the frequency



**Conducted Emission**

Product Type : Tubular motor  
 M/N : CM-03-E  
 Operating Condition : Mode: Tx\_433.92MHz  
 Test Specification : L-line  
 Comment : AC 120V/60Hz

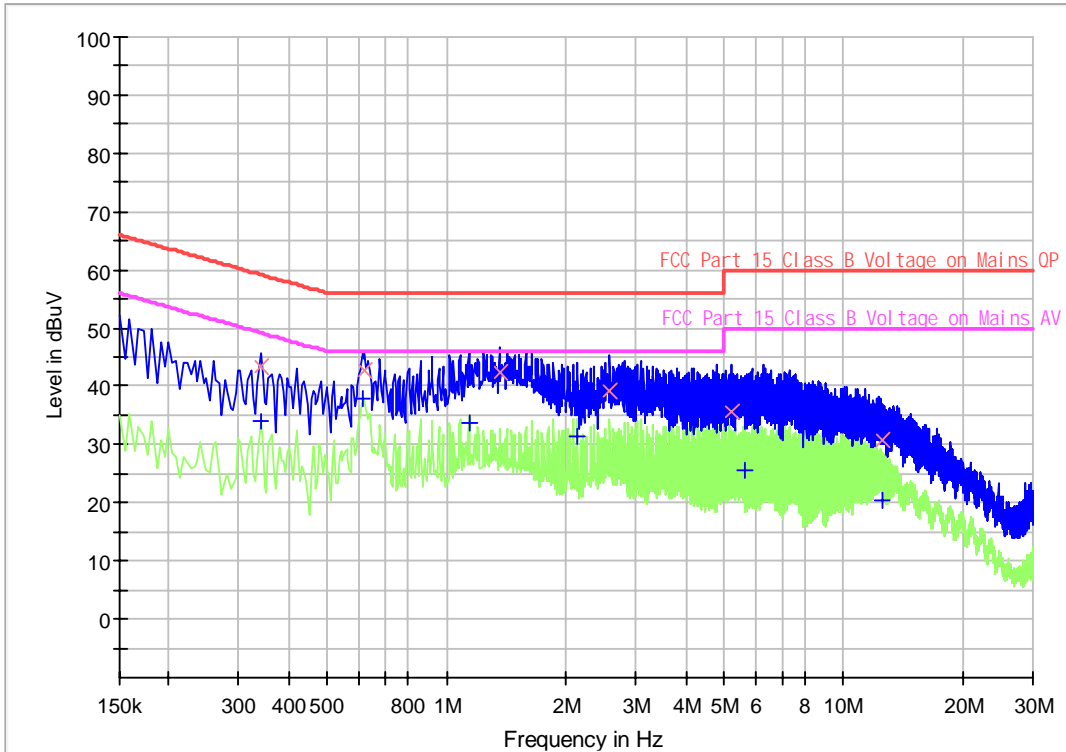

**Final Result**

Frequency (MHz)	QuasiPeak (dBuV)	CAverage (dBuV)	Limit (dBuV)	Margin (dB)	Meas. Time (ms)	Bandwidth (kHz)	Line	Corr. (dB)
0.339000	---	34.14	49.23	15.09	1000.0	9.000	L1	19.5
0.339000	43.49	---	59.23	15.74	1000.0	9.000	L1	19.5
0.613500	---	37.87	46.00	8.13	1000.0	9.000	L1	19.5
0.622500	42.62	---	56.00	13.38	1000.0	9.000	L1	19.5
1.140000	---	33.66	46.00	12.34	1000.0	9.000	L1	19.5
1.360500	42.35	---	56.00	13.65	1000.0	9.000	L1	19.5
2.139000	---	31.50	46.00	14.50	1000.0	9.000	L1	19.5
2.580000	39.18	---	56.00	16.82	1000.0	9.000	L1	19.5
5.239500	35.77	---	60.00	24.23	1000.0	9.000	L1	19.6
5.640000	---	25.58	50.00	24.42	1000.0	9.000	L1	19.6
12.462000	30.76	---	60.00	29.24	1000.0	9.000	L1	19.7
12.579000	---	20.32	50.00	29.68	1000.0	9.000	L1	19.7

Note 1: Measure Level (dBuV/m)= Reading Level (dBuV) + Factor (dB)  
 Factor (dB) =Cable Loss (dB) + LISN Factor (dB) + 10dB Attenuator



Product Type : Tubular motor  
 M/N : CM-03-E  
 Operating Condition : Mode: Tx\_433.92MHz  
 Test Specification : N-line  
 Comment : AC 120V/60Hz

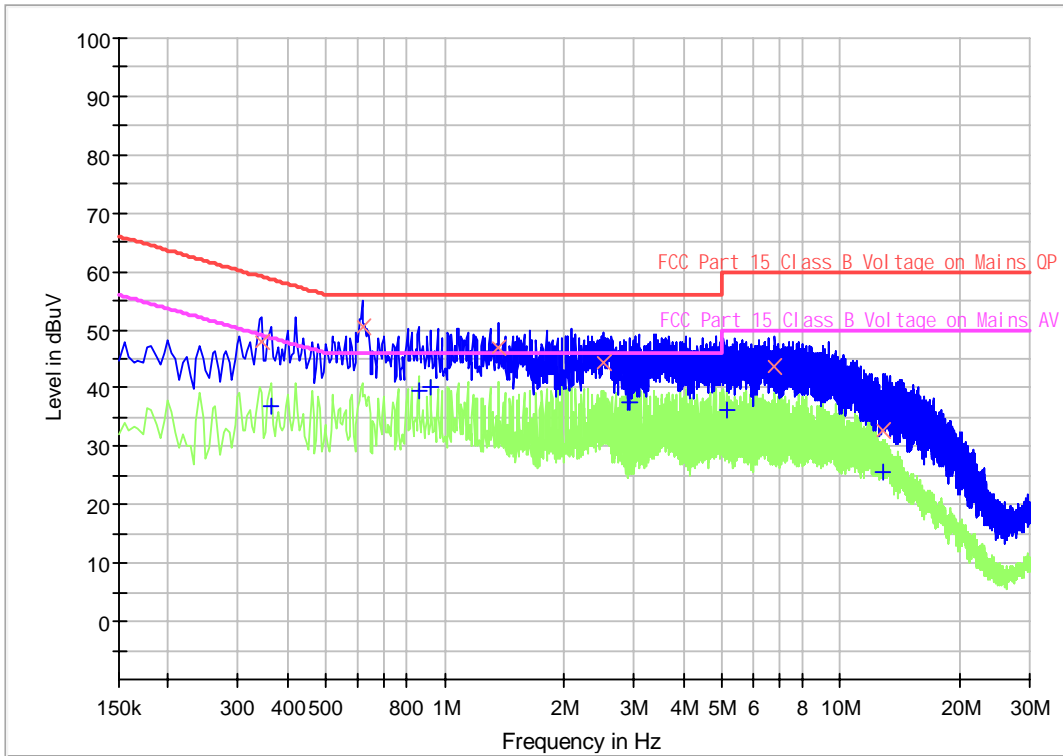

### Final Result

Frequency (MHz)	QuasiPeak (dBuV)	CAverage (dBuV)	Limit (dBuV)	Margin (dB)	Meas. Time (ms)	Bandwidth (kHz)	Line	Corr. (dB)
0.343500	47.78	---	59.12	11.34	1000.0	9.000	N	19.5
0.361500	---	37.04	48.69	11.65	1000.0	9.000	N	19.5
0.618000	50.51	---	56.00	5.49	1000.0	9.000	N	19.5
0.861000	---	39.35	46.00	6.65	1000.0	9.000	N	19.5
0.919500	---	40.23	46.00	5.77	1000.0	9.000	N	19.5
1.360500	47.09	---	56.00	8.91	1000.0	9.000	N	19.5
2.521500	44.37	---	56.00	11.63	1000.0	9.000	N	19.5
2.922000	---	37.59	46.00	8.41	1000.0	9.000	N	19.5
5.140500	---	36.11	50.00	13.89	1000.0	9.000	N	19.6
6.823500	43.75	---	60.00	16.25	1000.0	9.000	N	19.6
12.826500	32.70	---	60.00	27.30	1000.0	9.000	N	19.7
12.831000	---	25.66	50.00	24.34	1000.0	9.000	N	19.7

Note 1: Measure Level (dBuV/m)= Reading Level (dBuV) + Factor (dB)  
 Factor (dB) =Cable Loss (dB) + LISN Factor (dB) + 10dB Attenuator

## 9.2 Radiated Emission

### Test Method

1. The EUT was placed on a turn table which is 1.5m above ground plane for above 1GHz and 0.8m above ground for below 1GHz at 3 meters chamber room for test. The table was rotated 360 degrees to determine the position of the highest radiation.
2. Set to the maximum power setting and enable the EUT transmit continuously
3. The EUT was set 3 meters away from the interference – receiving antenna, which was mounted on the top of a variable – height antenna tower.
4. The height of antenna is varied from one meter to four meters above the ground to determine the maximum value of the field strength. Both horizontal and vertical polarizations of the antenna are set to make the measurement.
5. For each suspected emission, the EUT was arranged to its worst case and then the antenna was tuned to heights from 1 meter to 4 meters and the rotatable table was turned from 0 degrees to 360 degrees to find the maximum reading.
6. Use the following spectrum analyzer settings According to C63.10:
  - (1) Span shall wide enough to fully capture the emission being measured;
  - (2) Set RBW=100 kHz for  $f < 1$  GHz; VBW RBW; Sweep = auto; Detector function = peak; Trace = max hold;
  - (3) Set RBW = 1 MHz, VBW= 3MHz for  $f \geq 1$  GHz for peak measurement.
 For average measurement:  
 VBW = 10 Hz, when duty cycle is no less than 98 percent.  
 VBW  $\geq 1/T$ , when duty cycle is less than 98 percent where T is the minimum transmission duration over which the transmitter is on and is transmitting at its maximum power control level for the tested mode of operation.
7. Repeat above procedures until all frequencies measured were complete.

### Limit

According to §15.231 (b), the field strength of emissions from intentional radiators operated under this section shall not exceed the following:

Fundamental frequency (MHz)	Field Strength of Fundamental (Microvolts /meter)	Field Strength of spurious emissions ((Microvolts /meter)
40.66-40.70	2,250	225
70-130	1,250	125
130-174	1,250 to 3,750 *	125 to 375 *
174-260	3,750	375
260-470	3,750 to 12, 500*	375 to 1,250*
Above 470	12,500	1,250



### Limits for 15.209 Radiated emission limits; general requirements

Frequency (MHz)	Field strength (microvolts/meter)	Measurement distance (meters)
0.009-0.490	2400/F(kHz)	300
0.490-1.705	24000/F(kHz)	30
1.705-30.0	30	30
30-88	100	3
88-216	150	3
216-960	200	3
Above 960	500	3

Frequency	Limit at 3m (dBuV/m)
0.009 MHz – 0.490 MHz	128.5 to 93.8 <sup>1</sup>
0.490 MHz – 1.705 MHz	73.8 to 63 <sup>1</sup>
1.705 MHz – 30 MHz	69.5 <sup>1</sup>
30 MHz – 88 MHz	40.0 <sup>1</sup>
88 MHz – 216 MHz	43.5 <sup>1</sup>
216 MHz – 960 MHz	46.0 <sup>1</sup>
Above 960 MHz	54.0 <sup>1</sup>
Above 1000 MHz	54.0 <sup>2</sup>
Above 1000 MHz	74.0 <sup>3</sup>

<sup>1</sup>Limit is with detector with bandwidths as defined in CISPR-16-1-1 except for the frequency bands 9-90 kHz, 110-490 kHz and above 1000 MHz where an Average detector is used.

<sup>2</sup>Limit is with 1 MHz measurement bandwidth and using an Average detector

<sup>3</sup>Limit is with 1 MHz measurement bandwidth and using a Peak detector



**Spurious radiated emissions for transmitter**

According to C63.10, if the peak (or quasi-peak) measured value complies with the average limit, it is unnecessary to perform an average measurement, so AV emission value did not show in below table if the peak value complies with average limit.

Radiated Emission								
Value	Emissions	E-Field	Field	Average	Net Field	Limit	Margin	Emission Type
	Frequency	Polarity	Strength at 3m	Factor	Strength at 3m			
	MHz		dBµV/m	dB	dBµV/m	dBµV/m	dB	
PK	433.908	H	83.47	/	83.47	100.80	17.33	Fundamental
AV	433.908	H	83.47	-23.24	60.23	80.80	20.57	Fundamental
PK	325.41	H	29.29	/	29.29	46.00	16.71	restricted band
PK	864.68	H	39.92	/	39.92	80.80	40.88	Spurious
PK	1301.1	H	29.54	/	29.54	74.00	44.46	restricted band
PK	3036.9	H	37.78	/	37.78	80.80	43.02	Spurious
AV	3037.4	H	37.78	-23.24	14.54	60.80	46.26	Spurious
PK	3471.8	H	41.33	/	41.33	80.80	39.47	Spurious
AV	3471.8	H	41.33	-23.24	18.09	60.80	42.71	Spurious
PK	433.908	V	76.53	/	76.53	100.80	24.27	Fundamental
AV	433.908	V	76.53	-23.24	53.29	80.80	27.51	Fundamental
PK	864.15	V	40.03	/	40.03	80.80	40.77	Spurious
PK	2889.8	V	39.45	/	39.45	74.00	34.55	restricted band
PK	3036.2	V	38.26	/	38.26	80.80	42.54	Spurious
PK	3472.6	V	41.19	/	41.19	80.80	39.61	Spurious

Remark:

- 1: AV Emission Level= PK Emission Level+20log(dutycycle)
- 2: Corrected Amplitude = Read level + Corrector factor  
 Above 1GHz: Corrector factor = Antenna Factor + Cable Loss- Amplifier Gain  
 Below 1GHz: Corrector factor = Antenna Factor + Cable Loss
- 3. Correct Factor = Antenna Factor + Cable Loss (+ Amplifier, for higher than 1GHz)
- 4. Corrected Reading = Original Receiver Reading + Correct Factor
- 6. Only the worst data listed in this report
- 7. The other frequency was 20dB below the limit  
 Duty Cycle = 6.884ms/100 (ms) =6.884%  
 Duty Cycle Factor =20log (Duty Cycle) =-23.24



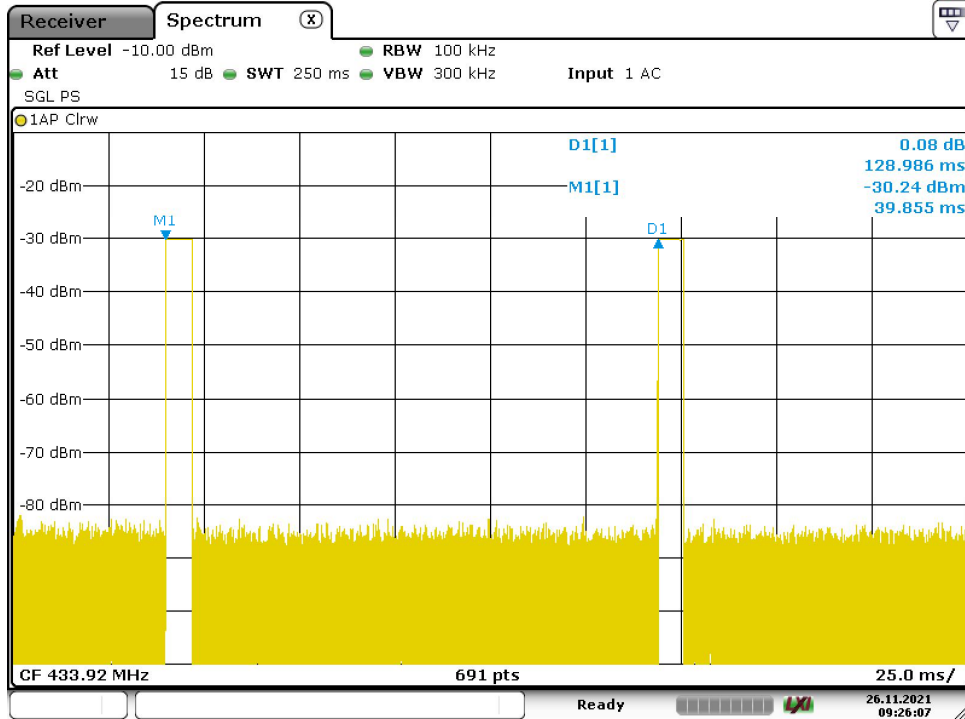

Date: 26.NOV.2021 09:26:08

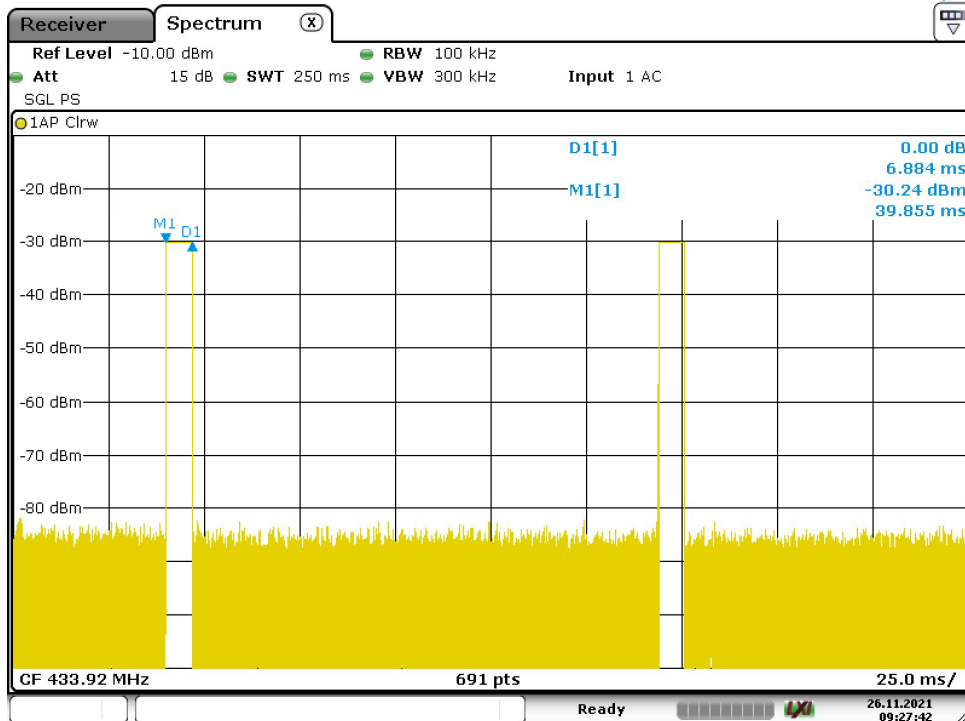

Date: 26.NOV.2021 09:27:43



## 9.3 Bandwidth Measurement

### Test Method

1. The RF output of EUT was connected to the test receiver by RF cable. The path loss was compensated to the results for each measurement.
2. Set to the maximum power setting and enable the EUT transmit continuously.
3. Use the following test receiver settings:  
Span = approximately 5 times the 20dB bandwidth, centered on a hopping channel  
RBW =1% to 5% of the 20dB bandwidth of the emission being measured, VBW≥RBW,  
Sweep = auto, Detector function = peak, Trace = max hold
4. Allow the trace to stabilize. Use the marker-to-peak function to set the marker to the peak of the emission. Measure the frequency difference of two frequencies that were attenuated 20 dB from the reference level. Record the frequency difference as the emission bandwidth. Record the results.
5. Repeat above procedures until all frequencies measured were complete.

### Limit

The bandwidth of the emission shall be no wider than 0.25% of the center frequency for devices operating above 70MHz and below 900MHz. For devices operating above 900MHz, the emission shall be no wider than 0.5% of the center frequency. Bandwidth is determined at the points 20dB down from the modulated carrier.

The limit for the EUT = 0.25% \* 433.91 MHz = 1084 kHz

### Test Result

Channel	20dB Bandwidth (KHz)	Limit (KHz)
1	81.00	1084

Channel	99% bandwidth (KHz)	Limit (KHz)
1	81.67	N/A

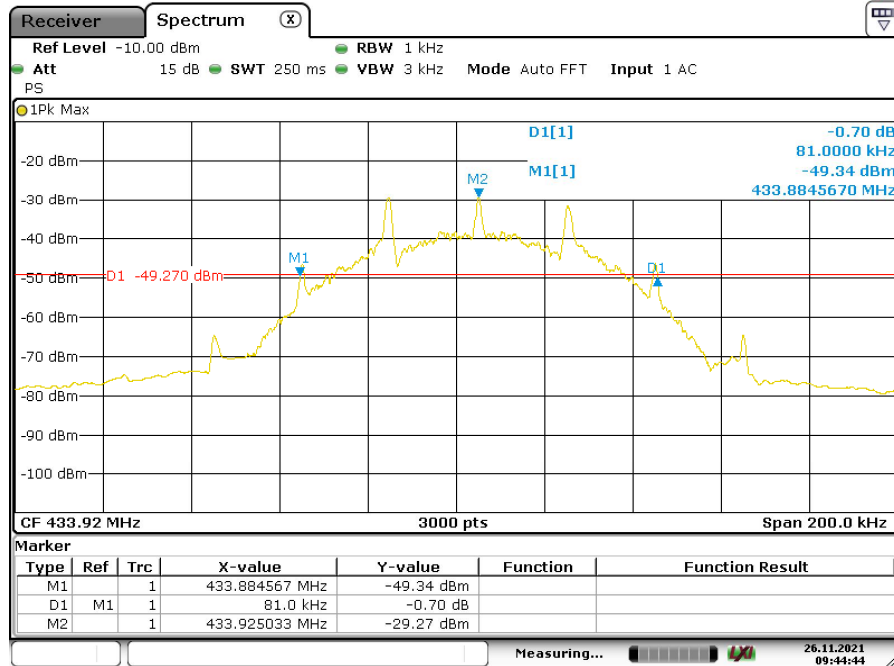

Date: 26.NOV.2021 09:44:44

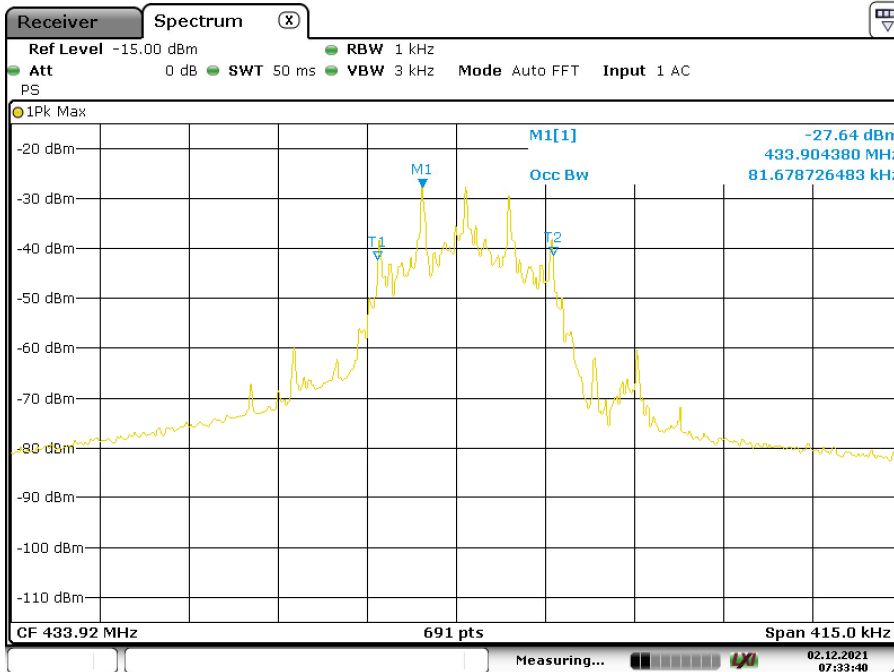

Date: 2.DEC.2021 07:33:41



## 9.4 Deactivation Time

### Test Method

1. The RF output of EUT was connected to the test receiver by RF cable. The path loss was compensated to the results for each measurement.
2. Set to the maximum power setting and enable the EUT in transmitting mode.
3. Set center frequency of spectrum analyzer=operating frequency.
4. Set the spectrum analyzer as RBW=120 KHz, VBW=1MHz, Span=0Hz.
5. Repeat above procedures until all frequency measured was complete.

### Limit

According to FCC Part 15.231 (a), the transmitter shall be complied the following requirements:

- (√) (1) A manually operated transmitter shall employ a switch that will automatically deactivate the transmitter within not more than 5 seconds of being released.
- (2) A transmitter activated automatically shall cease transmission within 5 seconds after activation.
- (3) Periodic transmissions at regular predetermined intervals are not permitted. However, polling or supervision transmissions, including data, to determine system integrity of transmitters used in security or safety applications are allowed if the total duration of transmissions does not exceed more than two seconds per hour for each transmitter. There is no limit on the number of individual transmissions, provided the total transmission time does not exceed two seconds per hour.

### Test Result

Channel	Frequency	Deactivation Time	Result
1	433.92MHz	159.4ms	Pass

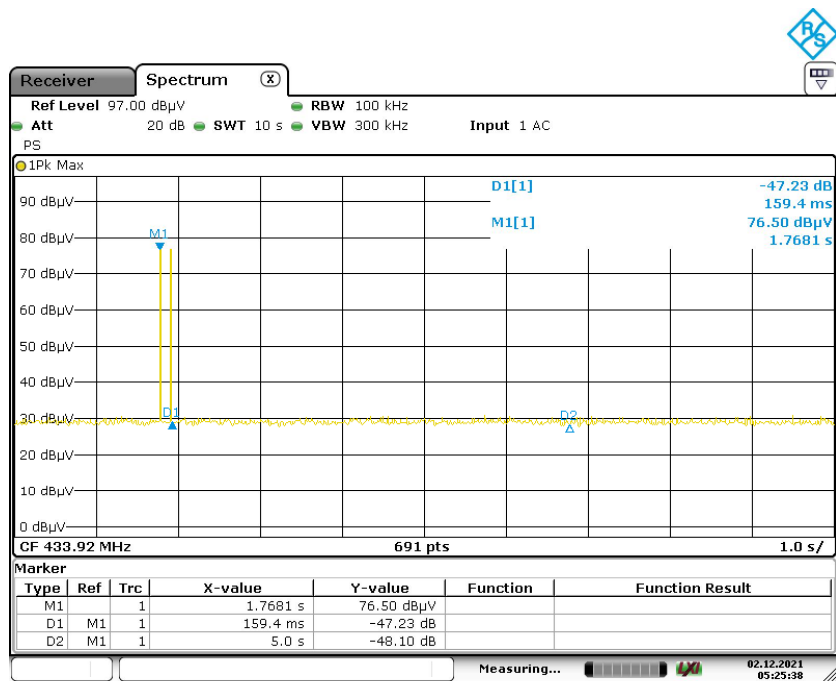

Date: 2.DEC.2021 05:25:38



## 10 Test Equipment List

### List of Test Instruments

#### RF Test

Description	Manufacturer	Model no.	Serial no.	Calibration Date	Calibration Due
Signal and spectrum analyzer	R&S	FSV40	S1503003-YQ-EMC	2021-8-02	2022-8-01

#### Radiated Emission Test

USED	Equipment Name	Model	Manufacturer	Equipment ID.	Calibration Date	Calibration Due
<input checked="" type="checkbox"/>	EMI test receiver	ESR3	R&S	S1503109-YQ-EMC	2021-8-02	2022-8-01
<input checked="" type="checkbox"/>	Trilog super broadband test antenna	SCHWARZBECK	VULB9168	S1808296-YQ-EMC	2019-3-16	2022-3-15
<input checked="" type="checkbox"/>	Double-ridged waveguide horn antenna	HF907	R&S	S1503009-YQ-EMC	2021-4-13	2024-4-12
<input checked="" type="checkbox"/>	Signal conditioning unit	SCU-18D	R&S	S1503012-YQ-EMC	2021-8-02	2022-8-01
<input checked="" type="checkbox"/>	Signal and spectrum analyzer	FSV40	R&S	S1503003-YQ-EMC	2021-8-02	2022-8-01
<input checked="" type="checkbox"/>	Loop antenna	HFH2-Z2	R&S	S1503013-YQ-EMC	2021-5-21	2022-5-20



## 11 System Measurement Uncertainty

For a 95% confidence level, the measurement expanded uncertainties for defined systems, in accordance with the recommendations of ISO 17025 were:

Items	Extended Uncertainty
Radiated Disturbance	30MHz to 1GHz, $\pm 5.03$ dB (Horizontal) $\pm 5.11$ dB (Vertical) 1GHz to 18GHz, $\pm 5.15$ dB (Horizontal) $\pm 5.12$ dB (Vertical) 18GHz to 25GHz, $\pm 4.76$ dB