



Product Operation Manual

OFF-ROAD PASSION MAD CROSS-COUNTRY RACING

CHOKING HAZARD-small parts,
not for children under 3 years.
It's possible difference between
pictures and real products!
FOR AGES 3 AND UP

1 Name of parts

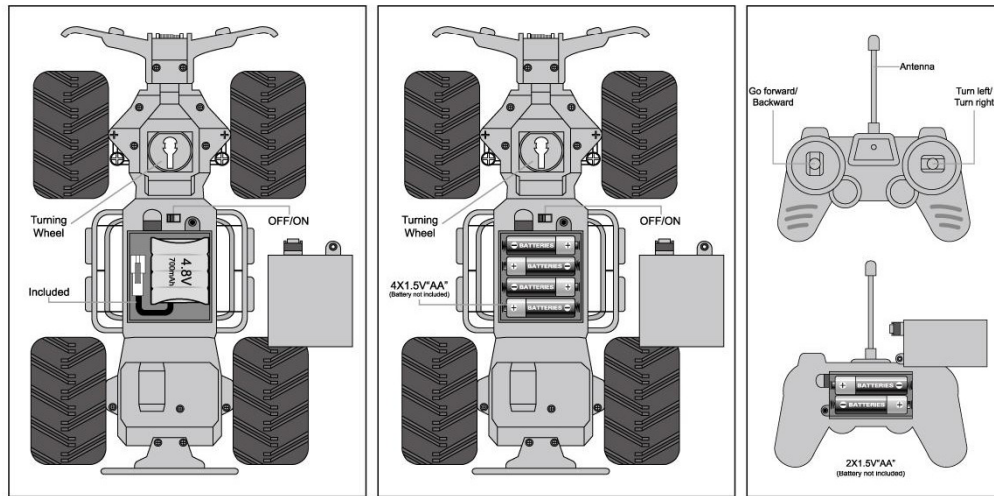

2 INSTALLATION OF BATTERIES & ANTENNA

- (1) Install 2x1.5V battery according to the polarity marks in the battery compartment.
- (2) Replace the battery cover.
- (3) Locate the hole on the top of the transmitter for installing the antenna. Insert the antenna in and turn clockwise to fix it.
- (4) Correctly install the rechargeable battery pack in the battery compartment and replace the battery cover.
- (5) Fasten the screw with a plus driver.

How to install battery in the transmitter

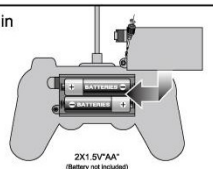

How to install battery in the car

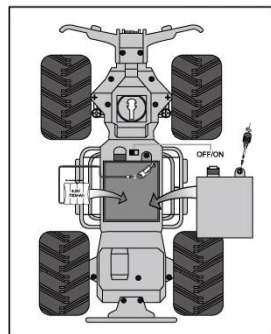

The car must charge with the special charger, be sure that the technology parameter is fit for the charger. Do not help yourselves to match a charger.

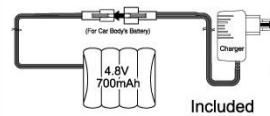

3 Basic Operation Of The Controller

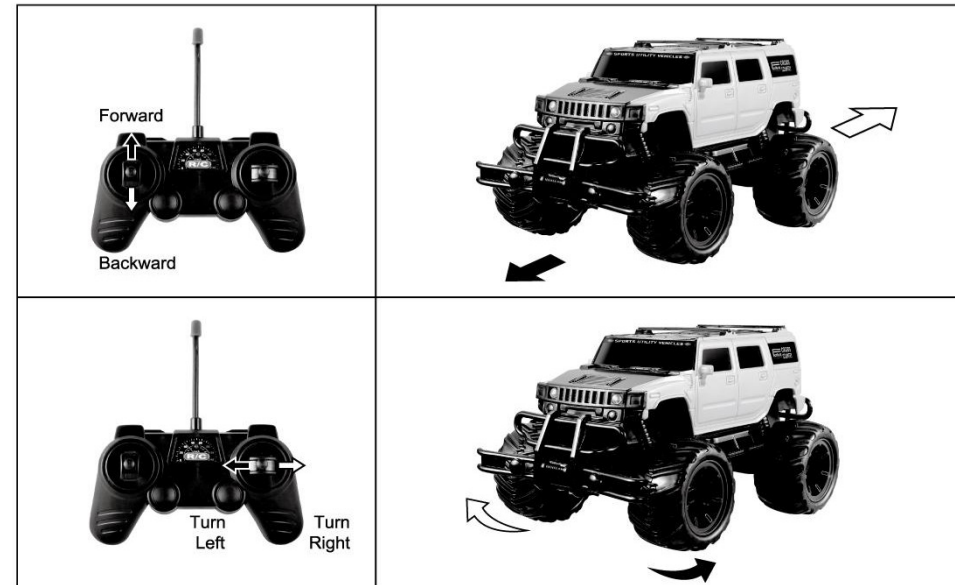

Caution: The user is cautioned that changes or modifications not expressly approved by the party responsible for compliance could void the user's authority to operate the equipment.
NOTE: This equipment has been tested and found to comply with the limits for a Class B digital device, pursuant to Part 15 of the FCC Rules. These limits are designed to provide reasonable protection against harmful interference in a residential installation. This equipment generates, uses and can radiate radio frequency energy and, if not installed and used in accordance with the instructions, may cause harmful interference to radio communications. However, there is no guarantee that interference will not occur in a particular installation.
If this equipment does cause harmful interference to radio or television reception, which can be determined by turning the equipment off and on, the user is encouraged to try to correct the interference by one or more of the following measures:

4 BATTERY SAFETY

- Reorient or relocate the receiving antenna.
 - Increase the separation between the equipment and receiver.
 - Connect the equipment into an outlet on a circuit different from that to which the receiver is connected.
 - Consult the dealer or an experienced radio/TV technician for help.
- (1) Adult's supervision is required for charging.
 - (2) To charge the rechargeable battery pack in the car, first remove it from the chassis.
 - (3) Timely remove exhausted batteries from the car and the transmitter.
 - (4) Make sure the main switch is set to OFF before installing the battery pack into the car body.
 - (5) Note polarity marks in the battery compartments when installing the batteries.
 - (6) Do not try to charge non-rechargeable batteries.
 - (7) Do not short-circuit the batteries.
 - (8) If you plan to stop use for a long time, remove the batteries from the transmitter and the car body to avoid leakage.
 - (9) Never throw the batteries into fire to avoid explosion or leakage.
 - (10) Do not mix batteries from different producers or new and old batteries.
 - (11) Use only recommended batteries or equivalent ones.
 - (12) Check the batteries on a regular basis to avoid leakage.
 - (13) Keep this manual well for future reference as it contains important information about this product.

This device complies with Part 15 of the FCC Rules. Operation is subject to the following two conditions: (1) this device may not cause harmful interference, and (2) this device must accept any interference received, including interference that may cause undesired operation.

5 USE CAUTIONS

-When the car is in motion, do not touch the wheels by hand to avoid damages to the car.



When there's more than one car played in the same place, set the cars to different bands to avoid mutual interference.



Do not bend the antenna or point it at other people or articles to avoid hurts.



Do not play in a place with puddle, mud or sand.