

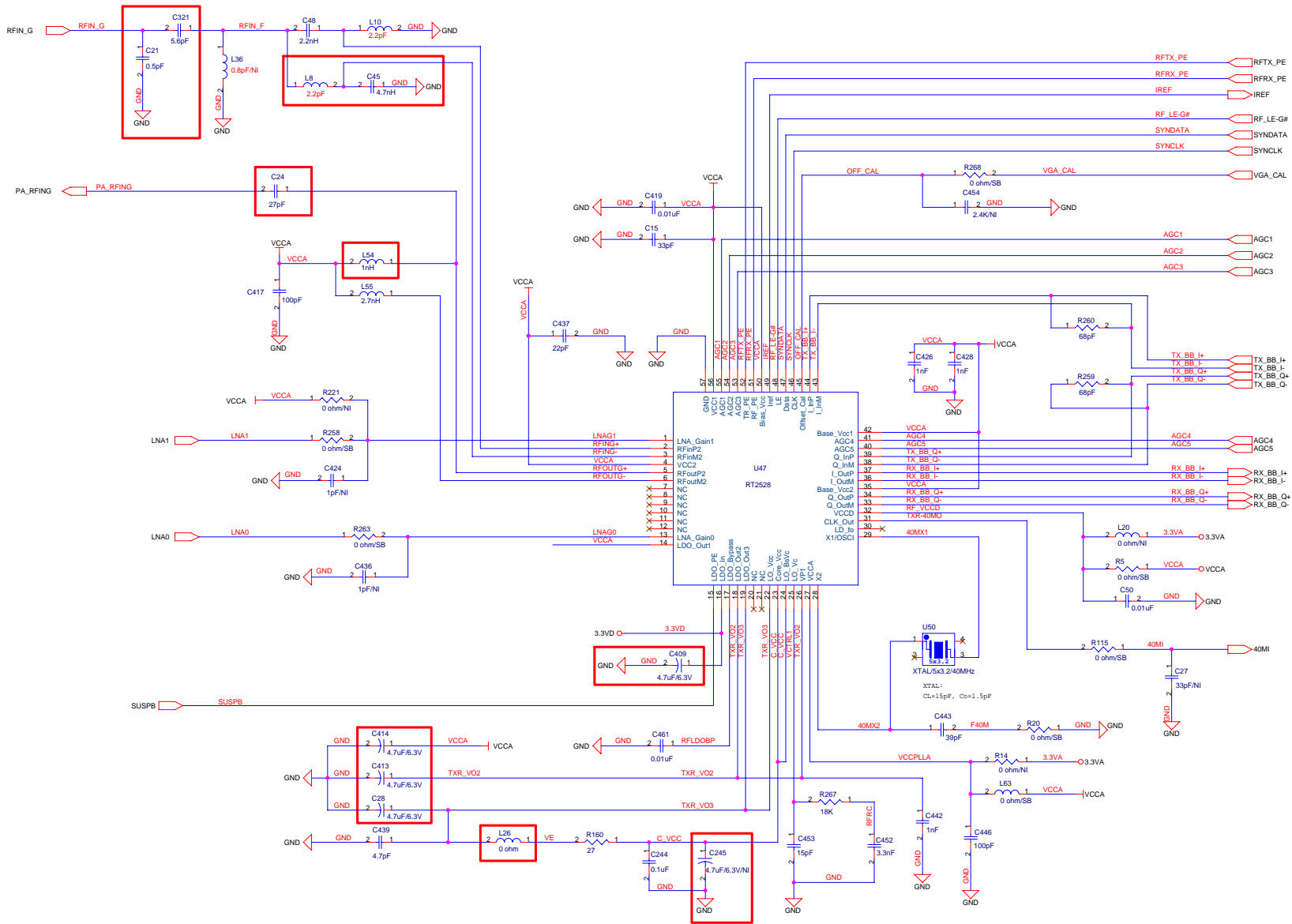

Filename:
 USB-PEN-RT2501W-V31ST-X-4L-NOBPF-060330.DSN

	RALINK TECHNOLOGY, CORP.		
	Title USB 2.0 PEN TYPE System - RT2571W + RT2528		
	Size B	Document Number USB-RT2501WUSB-V31ST-X.SCH	Rev 3.1
Date:	Friday, March 31, 2006	Sheet	1 of 5



**RALINK TECHNOLOGY, CORP.
CONFIDENTIAL**

		RALINK TECHNOLOGY, CORP.	
		File	Transceiver - RT2528
Size	C	Document Number	3-RT2528-xtal.SCH
Date	Friday, March 31, 2006	Sheet	2 of 5
		Rev	3.1

ANT 2412-2462MHz

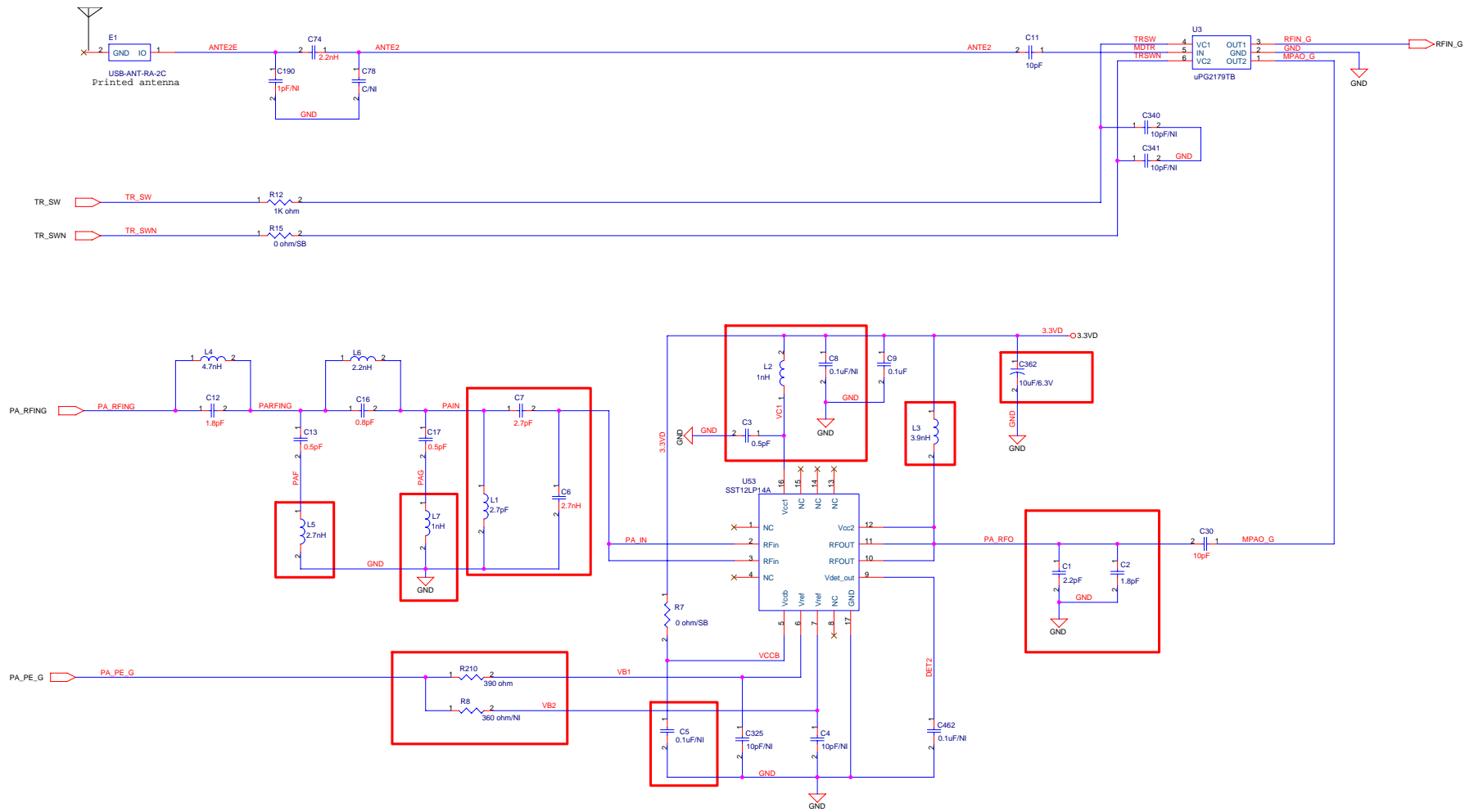

RALINK TECHNOLOGY, CORP.
CONFIDENTIAL

		RALINK TECHNOLOGY, CORP.	
		File	PA and TX/RX
Size	C	Document Number	2-PA-SSI12LP14A.SCH
Date	Friday, March 31, 2006	Sheet	3 of 5
		Rev	3.1

Mode	Install	Not Install
Internal 12Hz	R245, R247	C353, C354, R207, R246 R230, U38
External 12MHz	C353, C354, R207, R230, R246, U38	R245, R247

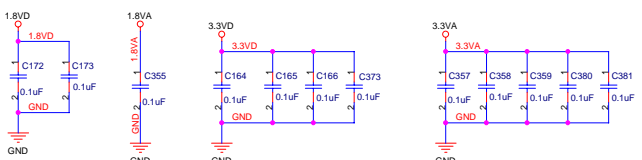
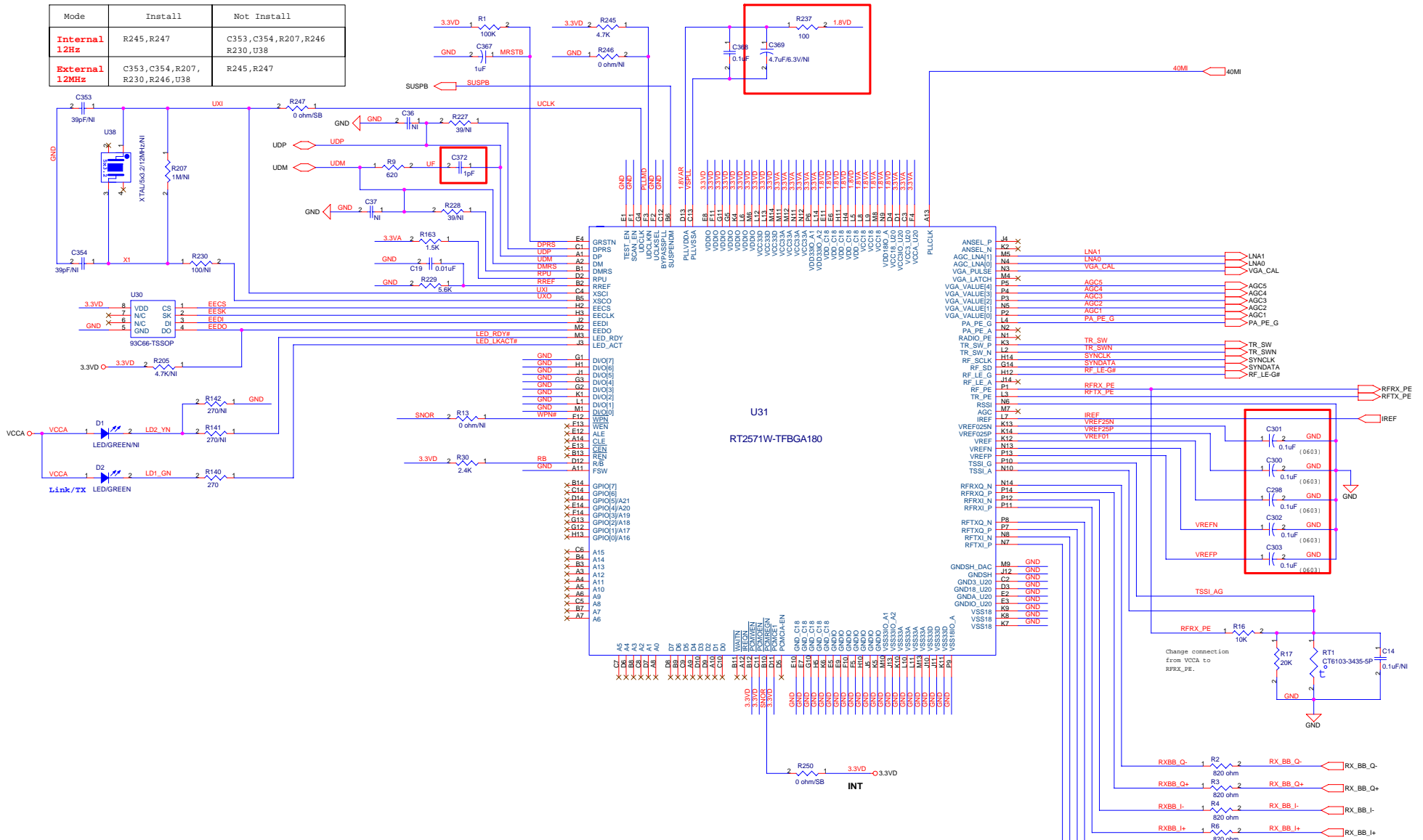

**RALINK TECHNOLOGY, CORP.
CONFIDENTIAL**

	RALINK TECHNOLOGY, CORP.		
	File	WLAN MAC+BBP - RT2571W	
	Size	Document Number	Rev
	C	4-RT2571W-WLAN.SCH	3.1
Date	Friday, March 31, 2006	Sheet	4 of 5

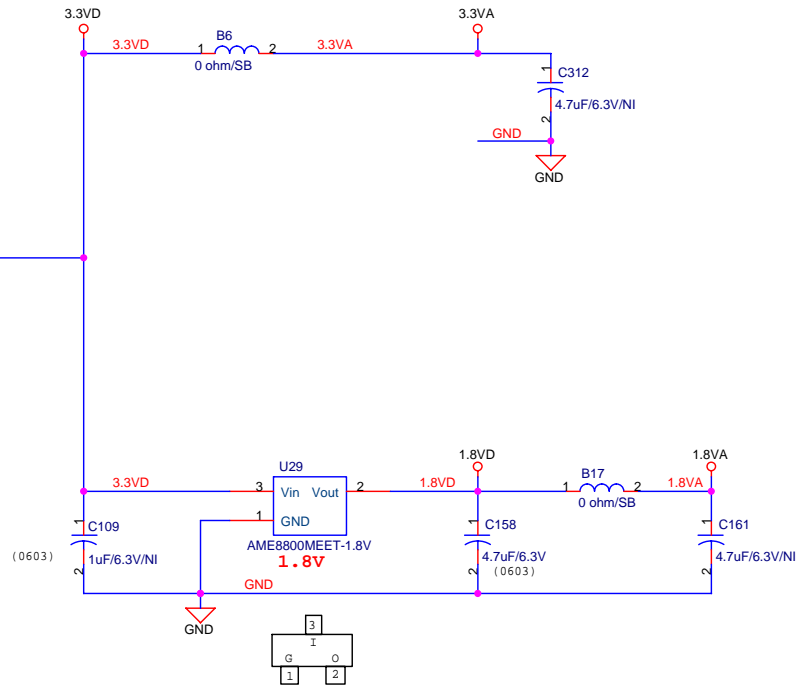
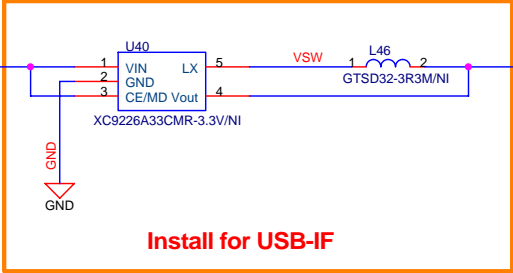
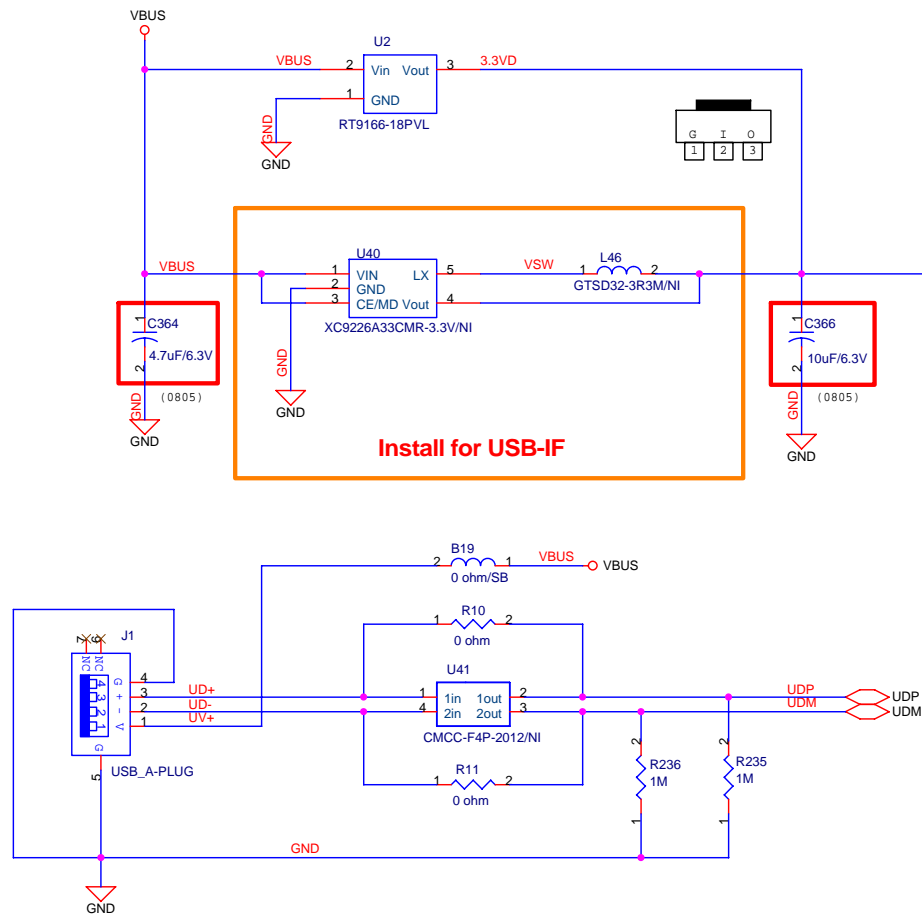

**RALINK TECHNOLOGY, CORP.
CONFIDENTIAL**

	RALINK TECHNOLOGY, CORP.		
	Title PEN USB Interface and Power		
	Size B	Document Number 5-USB-A.SCH	Rev 3.1
	Date Friday, March 31, 2006	Sheet 5 of 5	