





TEST REPORT

Applicant	Zhongshan Leetac Electronics Co., Ltd.
Address	No.3 Industrial Estate, South District, Zhongshan City, Guangdong province, P.R.China.

Manufacturer or Supplier	Zhongshan Leetac Electronics Co., Ltd.	
Address	No.3 Industrial Estate, South District, Zhongshan City, Guangdong province, P.R.China.	
Product	Wireless Hi-Frequency Headphones	
Brand Name	N/A	
Model	E-Z250	
Additional Model & Model Difference	E-Z250/ITGSH-300 /E-Z25X (X Will be replaced by digit "0-9", or letter "A-Z") See item 2.1	
Date of tests	Aug. 16-Aug.25, 2011	

- FCC Part 15, Subpart C:2009
- ANSI C63.4 : 2003

CONCLUSION: The submitted sample was found to COMPLY with the test requirement

Tested by David Liu Project Engineer / EMC Department	Approved by Sam Tung Manager / EMC Department
	
	Date: August.31, 2011

This report is for your exclusive use. Any copying or replication of this report to or for any other person or entity, or use of our name or trademark, is permitted only with our prior written permission. This report sets forth our findings solely with respect to the test samples identified herein. The results set forth in this report are not indicative or representative of the quality or characteristics of the lot from which a test sample was taken or any similar or identical product unless specifically and expressly noted. Our report includes all of the tests requested by you and the results thereof based upon the information that you provided to us. You have 60 days from date of issuance of this report to notify us of any material error or omission caused by our negligence, provided, however, that such notice shall be in writing and shall specifically address the issue you wish to raise. A failure to raise such issue within the prescribed time shall constitute your unqualified acceptance of the completeness of this report, the tests conducted and the correctness of the report contents. Unless specific mention, the uncertainty of measurement has been explicitly taken into account to declare the compliance or non-compliance to the specification



Table of Contents

RELEASE CONTROL RECORD	3
1 SUMMARY OF TEST RESULTS	4
1.1 MEASUREMENT UNCERTAINTY	4
GENERAL INFORMATION	5
1.2 GENERAL DESCRIPTION OF EUT	5
1.3 DESCRIPTION OF TEST MODES	7
1.4 DESCRIPTION OF SUPPORT UNITS	8
2 EMISSION TEST	9
2.1 CONDUCTED EMISSION MEASUREMENT	9
2.1.1 LIMITS OF CONDUCTED EMISSION MEASUREMENT	9
2.1.2 TEST INSTRUMENTS	9
2.1.3 TEST PROCEDURE	10
2.1.4 DEVIATION FROM TEST STANDARD	10
2.1.5 TEST SETUP	11
2.1.6 EUT OPERATING CONDITIONS	11
2.1.7 TEST RESULTS	12
2.1.1 TEST RESULTS	13
2.2 RADIATED EMISSION MEASUREMENT	14
2.2.1 LIMITS OF RADIATED EMISSION MEASUREMENT	14
2.2.2 TEST INSTRUMENTS	15
2.2.3 TEST PROCEDURE	16
2.2.4 DEVIATION FROM TEST STANDARD	16
2.2.5 TEST SETUP	17
2.2.6 EUT OPERATING CONDITIONS	17
2.2.7 TEST RESULTS(88-108MHZ)	18
2.2.8 TEST RESULTS (30-2000MHZ)	21
2.3 20 dB BANDWIDTH	24
2.3.1 TEST LIMITS	24
2.3.2 TEST PROCEDURE	24
2.3.3 TEST RESULT (PASS)	24
3 PHOTOGRAPHS OF TEST CONFIGURATION	26
4 APPENDIX A – MODIFICATIONS RECORDERS FOR ENGINEERING CHANGES TO THE EUT BY THE LAB	27



BUREAU
VERITAS

Test Report No.: FC110812N023

FCC ID ZXNLEETACEZ250

RELEASE CONTROL RECORD

ISSUE NO.	REASON FOR CHANGE	DATE ISSUED
Original release	N/A	August.3, 2011

Bureau Veritas Shenzhen Co., Ltd.
Dongguan Branch

No. 34, Chenwulu Section, Guantai Rd., Houjie
Town, Dongguan City,
Guangdong 523942, China

Tel.: +86 769 8593 5656
Fax: +86 769 8593 1080
Email: customerservice.dg@cn.bureauveritas.com



1 SUMMARY OF TEST RESULTS

The EUT has been tested according to the following specifications:

APPLIED STANDARD: FCC Part 15, Subpart C			
Standard Section	Test Item	Result	Remark
15.207	Conducted Emission Test	PASS	Meet Class B limit. Minimum passing margin is -27.90dB at 0.04625MHz
15.239	Radiated Emission Test	PASS	Meet Class B limit. Minimum passing margin is -10.62 at 196.61 MHz
15.215	20dB Bandwidth Test	PASS	N/A

Note : The maximum emission levels were compared with the requirements in section 15.207 and 15.239 of FCC Part 15 regulation.

1.1 MEASUREMENT UNCERTAINTY

Where relevant, the following measurement uncertainty levels have been estimated for tests performed on the EUT as specified in CISPR 16-4-2:

This uncertainty represents an expanded uncertainty expressed at approximately the 95% confidence level using a coverage factor of k=2.

MEASUREMENT	FREQUENCY	UNCERTAINTY
Conducted Emission	150kHz ~ 30MHz	2.56 dB
Radiated emissions	30MHz ~ 1GHz	3.58 dB



GENERAL INFORMATION

1.2 GENERAL DESCRIPTION OF EUT

PRODUCT	Wireless Hi-Frequency Headphones
MODEL NO.	E-Z250/ITGSH-300 /E-Z25X (X Will be replaced by digit "0-9",or letter "A-Z")
POWER SUPPLY	DC 3.7V (Li-ion Battery)or DC 7.5V with Adapter
MODULATION TYPE	FM
OPERATION FREQUENCY	88.3MHz, 97.9MHz, 107.7MHz
DATA CABLE SUPPLIED	DC Line: Unshielded,Undetachable 1.8m

NOTE:

1. The above model no. are identical in electrical, mechanical and physical construction, except with different model no. and tradename for trading purpose.
2. The EUT's high test operating frequency is less than 108MHz.
3. For the test results, the EUT had been tested with all conditions. But only the worst case was showed in test report.
4. The above EUT information was declared by manufacturer and for more detailed features description, please refer to the manufacturer's specifications or User's Manual.
5. After verified frequency range was verified and device did not have any controls to allow operation on any frequency other than the listed channels



ninety-eight channels are provided to this EUT.

Channel I	Freq. (MHz)	Channel	Freq. (MHz)	Channel	Freq. (MHz)	Channel	Freq. (MHz)	Channel	Freq. (MHz)
1	88.3	21	92.3	41	96.3	61	100.3	81	104.3
2	88.5	22	92.5	42	96.5	62	100.5	82	104.5
3	88.7	23	92.7	43	96.7	63	100.7	83	104.7
4	88.9	24	92.9	44	96.9	64	100.9	84	104.9
5	89.1	25	93.1	45	97.1	65	101.1	85	105.1
6	89.3	26	93.3	46	97.3	66	101.3	86	105.3
7	89.5	27	93.5	47	97.5	67	101.5	87	105.5
8	89.7	28	93.7	48	97.7	68	101.7	88	105.7
9	89.9	29	93.9	49	97.9	69	101.9	89	105.9
10	90.1	30	94.1	50	98.1	70	102.1	90	106.1
11	90.3	31	94.3	51	98.3	71	102.3	91	106.3
12	90.5	32	94.5	52	98.5	72	102.5	92	106.5
13	90.7	33	94.7	53	98.7	73	102.7	93	106.7
14	90.9	34	94.9	54	98.9	74	102.9	94	106.9
15	91.1	35	95.1	55	99.1	75	103.1	95	107.1
16	91.3	36	95.3	56	99.3	76	103.3	96	107.3
17	91.5	37	95.5	57	99.5	77	103.5	97	107.5
18	91.7	38	95.7	58	99.7	78	103.7	98	107.7
19	91.9	39	95.9	59	99.9	79	103.9		
20	92.1	40	96.1	60	100.1	80	104.1		



1.3 DESCRIPTION OF TEST MODES

The EUT was tested under the following modes, the final worst mode were marked in boldface and recorded in this report.

◆ **FOR MAINS TERMINAL DISTURBANCE VOLTAGE TEST:**

Test Result	Description of Test Mode	Remark
1	FM 88.3MHz	DC 7.5V from adapter input AC 120V/60Hz
2	FM 97.9MHz	
3	FM 107.7MHz	

For Other test, the EUT was tested under the following modes:

Test Result	Description of Test Mode	Remark
1	TX FM 88.3MHz	DC 7.5V from adapter input AC 120V/60Hz
2	TX FM 97.9MHz	
3	TX FM 107.7MHz	

Note : The test signal we used max lever craze music.



DESCRIPTION OF SUPPORT UNITS

The EUT has been tested as an independent unit together with other necessary accessories or support units. The following support units or accessories were used to form a representative test configuration during the tests.

NO.	PRODUCT	BRAND	MODEL NO.	SERIAL NO.	FCC ID
1	Iphone	APPLE	A1332	N/A	BCG-E2380B
2	Adapter	S&S	UA200-75	E199558	N/A

NO.	SIGNAL CABLE DESCRIPTION OF THE ABOVE SUPPORT UNITS
1	Audio In Line: Unshielded; Detachable <u>1.8</u> m
2	DC Line: Unshielded <u>1.5</u> m

TEST CONFIGURATION

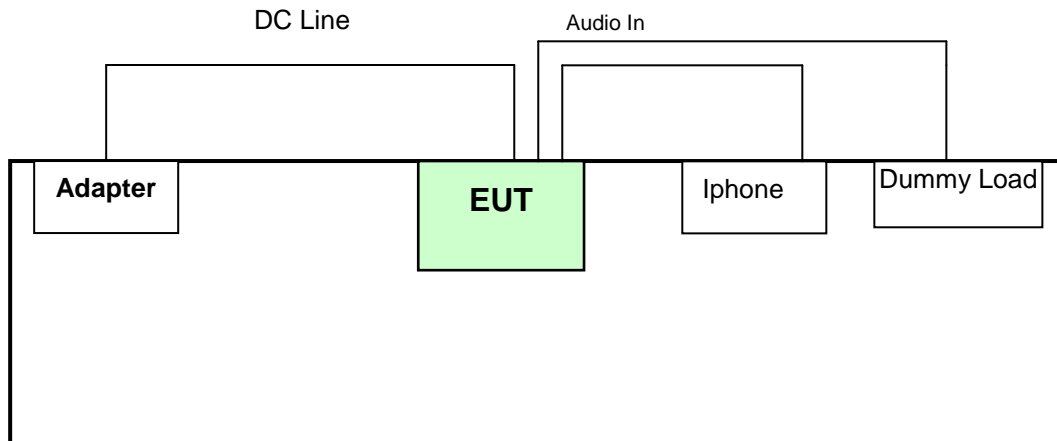



2 EMISSION TEST

2.1 CONDUCTED EMISSION MEASUREMENT

2.1.1 LIMITS OF CONDUCTED EMISSION MEASUREMENT

TEST STANDARD: FCC Part 15, Subpart C (Section: 15.207)

FREQUENCY (MHz)	Class A (dBuV)		Class B (dBuV)	
	Quasi-peak	Average	Quasi-peak	Average
0.15 - 0.5	79	66	66 - 56	56 - 46
0.50 - 5.0	73	60	56	46
5.0 - 30.0	73	60	60	50

- NOTES:**
- (1) The lower limit shall apply at the transition frequencies.
 - (2) The limit decreases in line with the logarithm of the frequency in the range of 0.15 to 0.50 MHz.
 - (3) All emanations from a class A/B digital device or system, including any network of conductors and apparatus connected thereto, shall not exceed the level of field strengths specified above.

2.1.2 TEST INSTRUMENTS

DESCRIPTION & MANUFACTURER	MODEL NO.	SERIAL NO.	CALIBRATED DATE	CALIBRATED UNTIL
EMI Test Receiver	ESCS30	100199	May 25,11	May 25,12
Artificial Mains Network	ESH3-Z5	100317	May 25,11	May 25,12
Artificial Mains Network (AUX)	ENV216	101173	May 25,11	May 25,12
Pulse Limiter	ESH3-Z2	100168	May 2,11	May 2,12

- NOTE:**
1. The calibration interval of the above test instruments is 12 months. And the calibrations are traceable to CEPREI/CHINA and NIM/CHINA.
 2. The test was performed at Shielded Room 743,



**BUREAU
VERITAS**

Test Report No.: FC110812N023

FCC ID ZXNLEETACEZ250

2.1.3 TEST PROCEDURE

The basic test procedure was in accordance with ANSI C63.4:2009 (section 7).

- a. The EUT was placed 0.4 meters from the conducting wall of the shielded room with EUT being connected to the power mains through a line impedance stabilization network (LISN). Other support units were connected to the power mains through another LISN. The two LISNs provide 50 Ohm/ 50uH of coupling impedance for the measuring instrument.
- b. Both lines of the power mains connected to the EUT were checked for maximum conducted interference.
- c. The frequency range from 150 kHz to 30 MHz was searched. Emission levels under (Limit - 20dB) were not recorded.

NOTE:

1. Q.P. and AV. are abbreviations of quasi-peak and average individually.
2. "-": The Quasi-peak reading value also meets average limit and measurement with the average detector is unnecessary.
3. Margin value = Emission level - Limit value
4. Correction factor = Insertion loss + Cable loss
5. Emission Level = Correction Factor + Reading Value.

2.1.4 DEVIATION FROM TEST STANDARD

No deviation



2.1.5 TEST SETUP

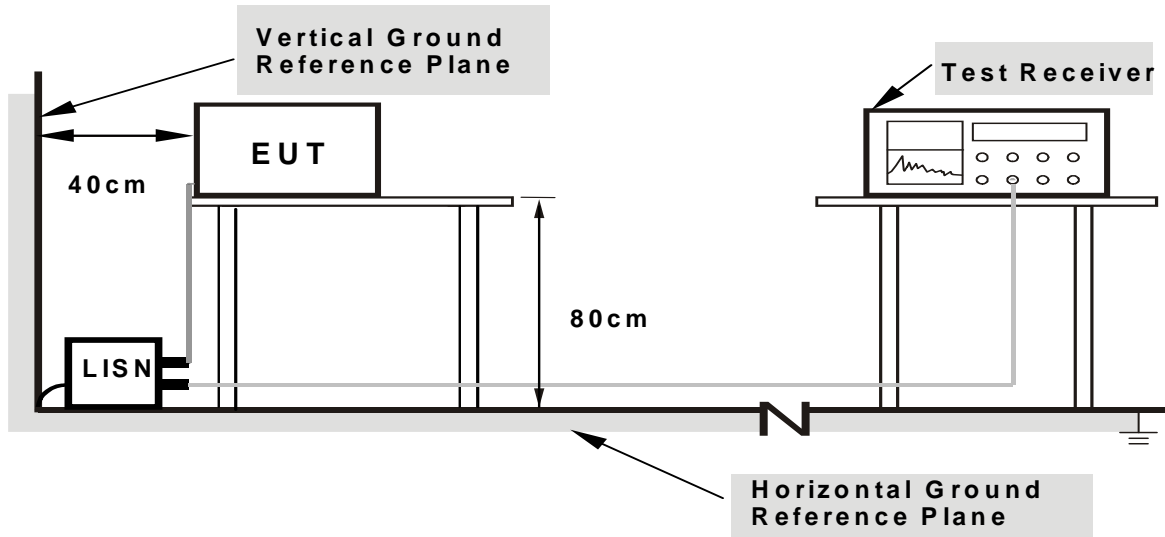

- Note:**
1. Support units were connected to second LISN.
 2. Both of LISNs (AMN) are 80cm from EUT and at least 80cm from other units and other metal planes support units.

2.1.6 EUT OPERATING CONDITIONS

- a. Turned on the power of all equipment.
- b. EUT was operated according to the type used was description in manufacturer's specifications or the User's Manual.



2.1.7 TEST RESULTS

TEST MODE	MP3 playing,middle channel	PHASE	Line(L)
INPUT POWER	DC 7.5V From Adapter Input AC 120V/60Hz	6dB BANDWIDTH	9 kHz
ENVIRONMENTAL CONDITIONS	25 deg. C, 55% RH,	TESTED BY: David Liu	

No	Freq. [MHz]	Corr. Factor (dB)	Reading Value [dB (uV)]		Emission Level [dB (uV)]		Limit [dB (uV)]		Margin (dB)	
			Q.P.	AV.	Q.P.	AV.	Q.P.	AV.	Q.P.	AV.
			1	0.16562	9.64	22.83	10.76	32.47	20.40	65.18
2	0.22812	9.62	20.70	9.70	30.32	19.32	62.52	52.52	-32.20	-33.20
3	0.30234	9.56	19.59	11.55	29.15	21.11	60.18	50.18	-31.03	-29.07
4	0.38438	9.50	18.40	8.39	27.90	17.89	58.18	48.18	-30.29	-30.30
5	0.46250	9.44	19.31	7.17	28.75	16.61	56.65	46.65	-27.90	-30.04
6	0.91172	9.87	16.80	9.14	26.67	19.01	56.00	46.00	-29.33	-26.99

REMARKS: The emission levels of other frequencies were very low against the limit.

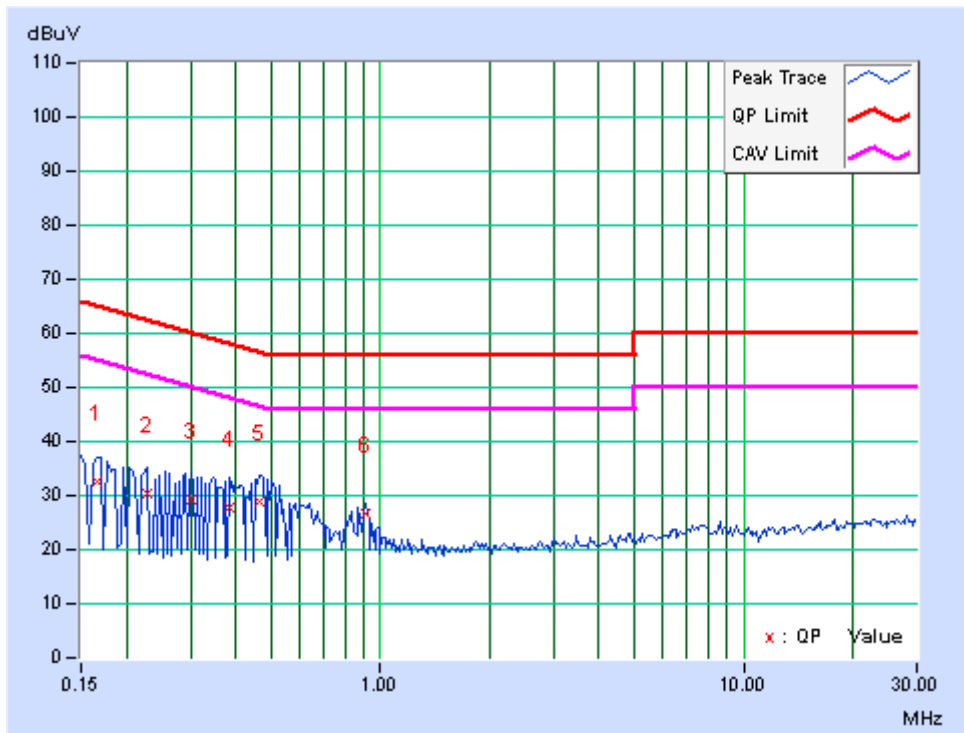



2.1.1 TEST RESULTS

TEST MODE	MP3 playing,middle channel	PHASE	Line(N)
INPUT POWER	DC 7.5V From Adapter Input AC 120V/60Hz	6dB BANDWIDTH	9 kHz
ENVIRONMENTAL CONDITIONS	25 deg. C, 55% RH,	TESTED BY: David Liu	

No	Freq. [MHz]	Corr. Factor (dB)	Reading Value		Emission Level		Limit		Margin	
			[dB (uV)]		[dB (uV)]		[dB (uV)]		(dB)	
			Q.P.	AV.	Q.P.	AV.	Q.P.	AV.	Q.P.	AV.
1	0.16562	9.63	22.00	10.19	31.63	19.82	65.18	55.18	-33.55	-35.36
2	0.22812	9.61	19.54	9.04	29.15	18.65	62.52	52.52	-33.37	-33.87
3	0.24375	9.60	18.94	9.31	28.54	18.91	61.97	51.97	-33.43	-33.06
4	0.45078	9.45	14.14	7.64	23.59	17.09	56.86	46.86	-33.27	-29.77
5	0.62266	9.59	12.86	6.12	22.45	15.71	56.00	46.00	-33.55	-30.29
6	0.83750	9.81	12.92	7.38	22.73	17.19	56.00	46.00	-33.27	-28.81

REMARKS: The emission levels of other frequencies were very low against the limit.

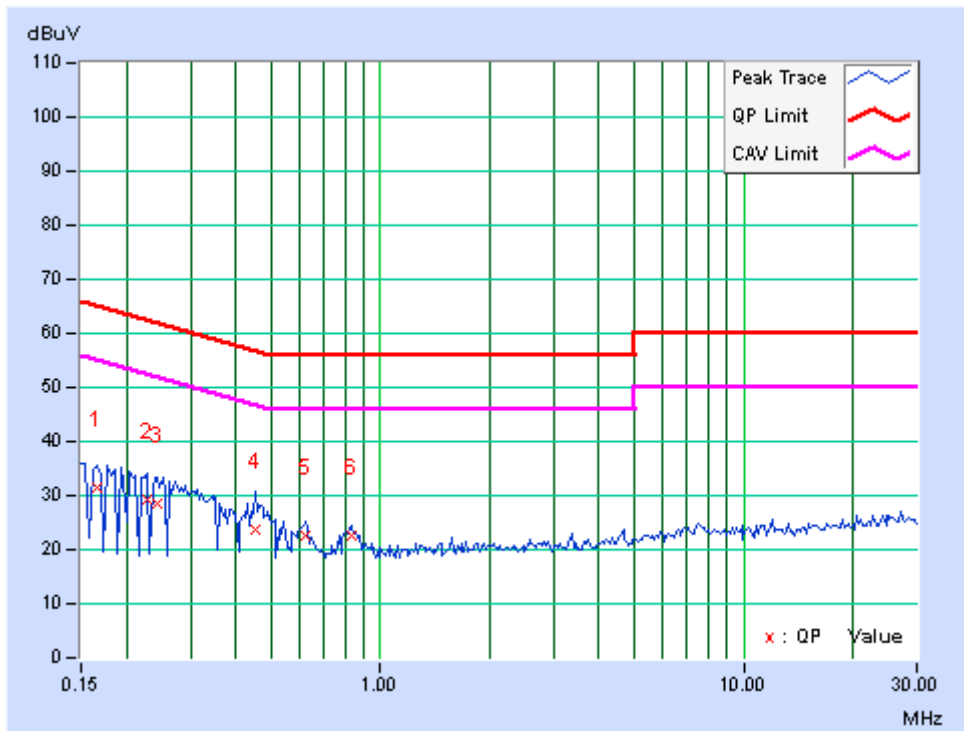



2.2 RADIATED EMISSION MEASUREMENT

2.2.1 LIMITS OF RADIATED EMISSION MEASUREMENT

TEST STANDARD: FCC Part 15, Subpart C (Section: 15.239)

FREQUENCY (MHz)	Limits	
	PK(dBuV/m)	AV(dBuV/m)
88~108	67.9	47.9

Limits for Radiated Emissions [FCC 47 CFR 15.209]:

Frequency Range [MHz]	Quasi-Peak Limits [μV/m]
1.705-30	300
30-88	100
88-216	150
216-960	200
Above960	500

- Note: (1) The lower limit shall apply at the transition frequencies.
(2) Emission level (dBuV/m) = 20 log Emission level (uV/m).
(3) All emanation from a class A/B digital device or system, including any network of conductors and apparatus connected thereto, shall not exceed the level of field strengths specified above.



2.2.2 TEST INSTRUMENTS

For radiated emission test (30MHz-1GHz,10m Chamber)

DESCRIPTION & MANUFACTURER	MODEL NO.	SERIAL NO.	DATE OF CALIBRATION	DUE DATE OF CALIBRATION
Spectrum Analyzer Agilent	E4446A	MY46180622	Apr. 25, 2011	Apr. 24, 2012
BILOG Antenna Teseq	CBL 6111D	25758	Nov.22,2010	Nov.22,2011
HORN Antenna EMCO	3117	00085519	Nov.01,2010	Nov.01,2011
Signal Generator Rohde&Schwarz	SMF100A	101431	Jan. 12, 2011	Jan. 01, 2012
Preamplifier BURGEON	PEC-38-3018G-12 -SFF	NSEMC001	Oct.16,2010	Oct.16,2011
Preamplifier Agilent	8447D	2944A11174	May 2,2011	May 2,2012
Software ADT.	ADT_Radiated V7.5.14	NA	NA	NA
Temperature & Humidity chamber Giant Force	ITH-150-70-CP-AR	IAA0602-002	Apr. 18, 2011	Apr. 17, 2012

For 20dB bandwidth test

Equipment	Manufacturer	Model No.	Serial No.	Last Cal.	Next Cal.
Spectrum Analyzer	Rohde & Schwarz	FSL	100302	May 25,2011	May 25,2012

- NOTE:**
1. The calibration interval of the above test instruments is 12 months. And the calibrations are traceable to CEPREI/CHINA and NIM/CHINA.
 2. The test was performed at 966 Chamber (a 3m Semi-semi anechoic chamber).
 3. The test was performed in Shielded Room 20.



2.2.3 TEST PROCEDURE

The basic test procedure was in accordance with ANSI C63.4 (section 12).

- a. The EUT was placed on the top of a rotating table 0.8 meters above the ground at a 3 meters Semi-anechoic chamber room. The table was rotated 360 degrees to determine the position of the highest radiation.
- b. The EUT was set 3 meters away from the interference-receiving antenna, which was mounted on the top of a variable-height antenna tower.
- c. The height of antenna is varied from one meter to four meters above the ground to determine the maximum value of the field strength. Both horizontal and vertical polarizations of the antenna are set to make the measurement.
- d. For each suspected emission, the EUT was arranged to its worst case and then the antenna was tuned to heights from 1 meter to 4 meters and the rotatable table was turned from 0 degrees to 360 degrees to find the maximum reading.
- e. The test-receiver system was set to quasi-peak detect function and specified bandwidth with maximum hold mode when the test frequency is below 1 GHz.
- f. The test-receiver system was set to peak and average detect function and specified bandwidth with maximum hold mode when the test frequency is above 1 GHz.

NOTE:

1. The resolution bandwidth of test receiver/spectrum analyzer is 120kHz for Quasi-peak detection (QP) at frequency below 1GHz.
2. The resolution bandwidth is 1MHz and video bandwidth of test receiver/spectrum analyzer is 3MHz for Peak detection at frequency above 1GHz. The resolution bandwidth of test receiver/spectrum analyzer is 1 MHz for Average detection (AV) at frequency above 1GHz.
3. For measurement of frequency above 1000 MHz, the EUT was set 3 meters away from the receiver antenna.
4. Emission level(dBuV/m)=Raw Value(dBuV) + Correction Factor(dB/m)
5. Correction Factor(dB/m) = Antenna Factor (dB/m) + Cable Factor (dB)
6. Margin value = Emission level – Limit value.

2.2.4 DEVIATION FROM TEST STANDARD

No deviation



2.2.5 TEST SETUP

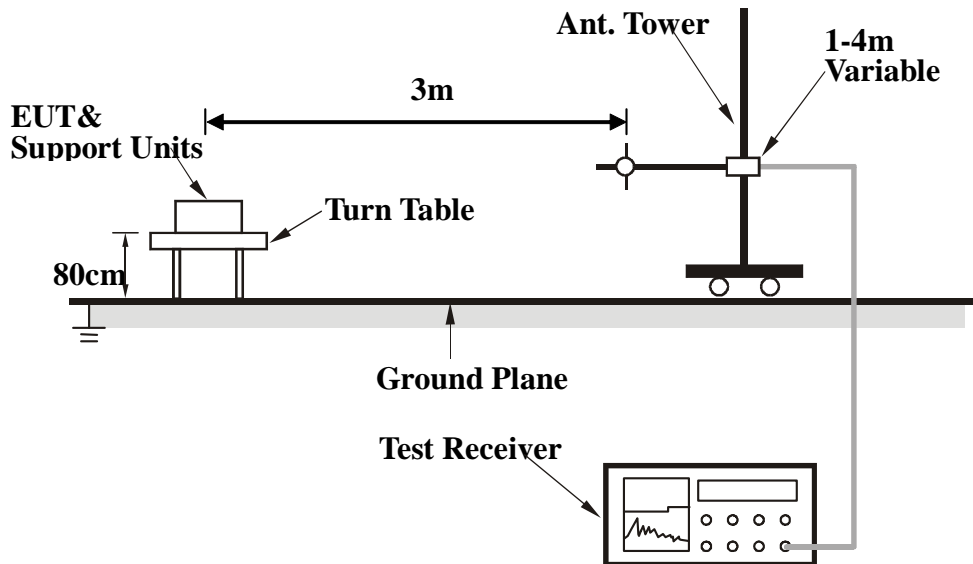

2.2.6 EUT OPERATING CONDITIONS

See Item 3.1.6



2.2.7 TEST RESULTS(88-108MHZ)

TEST MODE	MP3 Playing Mode	MODEL NO.	E-Z250
INPUT POWER (SYSTEM)	DC 7.5V from input 120V 60Hz	FREQUENCY RANGE	88-108 MHz
ENVIRONMENTAL CONDITIONS	25 deg. C, 55% RH,	DETECTOR FUNCTION & BANDWIDTH	Peak and Average, 120 kHz
TESTED BY	David Liu		

ANTENNA POLARITY & TEST DISTANCE: HORIZONTAL AT 3 M								
No.	Freq. (MHz)	Emission Level (dBuV/m)	Limit (dBuV/m)	Margin (dB)	Antenna Height (cm)	Table Angle (Degree)	Raw Value (dBuV)	Correction Factor (dB/m)
1	88.3	31.75PK	67.9	-36.15	155	120	22.52	9.23
2	88.3	29.65AV	47.9	-18.25	155	120	20.42	9.23

TEST MODE	MP3 Playing Mode	MODEL NO.	E-Z250
INPUT POWER (SYSTEM)	DC 7.5V from input 120V 60Hz	FREQUENCY RANGE	88-108 MHz
ENVIRONMENTAL CONDITIONS	25 deg. C, 55% RH,	DETECTOR FUNCTION & BANDWIDTH	Peak and Average, 120 kHz
TESTED BY	David Liu		

ANTENNA POLARITY & TEST DISTANCE: VERTICAL AT 3 M								
No.	Freq. (MHz)	Emission Level (dBuV/m)	Limit (dBuV/m)	Margin (dB)	Antenna Height (cm)	Table Angle (Degree)	Raw Value (dBuV)	Correction Factor (dB/m)
1	88.3	29.75 PK	67.9	-38.15	200	66	20.52	9.23
2	88.3	23.75 AV	47.9	-24.15	200	66	14.49	9.23

- REMARKS:**
1. Emission level(dBuV/m)=Raw Value(dBuV) + Correction Factor(dB/m)
 2. Correction Factor(dB/m) = Antenna Factor (dB/m) + Cable Factor (dB)
 3. The other emission levels were very low against the limit.
 4. Margin value = Emission level – Limit value.



TEST MODE	MP3 Playing Mode	MODEL NO.	E-Z250
INPUT POWER (SYSTEM)	DC 7.5V from input 120V 60Hz	FREQUENCY RANGE	88-108 MHz
ENVIRONMENTAL CONDITIONS	25 deg. C, 55% RH,	DETECTOR FUNCTION & BANDWIDTH	Peak and Average, 120 kHz
TESTED BY	David Liu		

ANTENNA POLARITY & TEST DISTANCE: HORIZONTAL AT 3 M

No.	Freq. (MHz)	Emission Level (dBuV/m)	Limit (dBuV/m)	Margin (dB)	Antenna Height (cm)	Table Angle (Degree)	Raw Value (dBuV)	Correction Factor (dB/m)
1	97.9	38.03 PK	67.9	-29.87	124	149	27.42	10.61
2	97.9	35.73 AV	47.9	-12.17	124	149	25.12	10.61

TEST MODE	MP3 Playing Mode	MODEL NO.	E-Z250
INPUT POWER (SYSTEM)	DC 7.5V from input 120V 60Hz	FREQUENCY RANGE	88-108 MHz
ENVIRONMENTAL CONDITIONS	25 deg. C, 55% RH,	DETECTOR FUNCTION & BANDWIDTH	Peak and Average, 120 kHz
TESTED BY	David Liu		

ANTENNA POLARITY & TEST DISTANCE: VERTICAL AT 3 M

No.	Freq. (MHz)	Emission Level (dBuV/m)	Limit (dBuV/m)	Margin (dB)	Antenna Height (cm)	Table Angle (Degree)	Raw Value (dBuV)	Correction Factor (dB/m)
1	97.9	41.69 PK	67.90	-26.15	122	140	31.08	10.61
2	97.9	30.32 AV	47.90	-7.64	122	140	19.71	10.61

- REMARKS:**
1. Emission level(dBuV/m)=Raw Value(dBuV) + Correction Factor(dB/m)
 2. Correction Factor(dB/m) = Antenna Factor (dB/m) + Cable Factor (dB)
 3. The other emission levels were very low against the limit.
 4. Margin value = Emission level – Limit value.



TEST MODE	MP3 Playing Mode	MODEL NO.	E-Z250
INPUT POWER (SYSTEM)	DC 7.5V from input 120V 60Hz	FREQUENCY RANGE	88-108 MHz
ENVIRONMENTAL CONDITIONS	25 deg. C, 55% RH,	DETECTOR FUNCTION & BANDWIDTH	Peak and Average, 120 kHz
TESTED BY	David Liu		

ANTENNA POLARITY & TEST DISTANCE: HORIZONTAL AT 3 M

No.	Freq. (MHz)	Emission Level (dBuV/m)	Limit (dBuV/m)	Margin (dB)	Antenna Height (cm)	Table Angle (Degree)	Raw Value (dBuV)	Correction Factor (dB/m)
1	107.7	46.71PK	67.9	-21.19	108	225	35.00	11.71
2	107.7	45.96 AV	47.9	-1.94	108	225	34.25	11.71

TEST MODE	MP3 Playing Mode	MODEL NO.	E-Z250
INPUT POWER (SYSTEM)	DC 7.5V from input 230V 60Hz	FREQUENCY RANGE	88-108 MHz
ENVIRONMENTAL CONDITIONS	25 deg. C, 55% RH,	DETECTOR FUNCTION & BANDWIDTH	Peak and Average, 120 kHz
TESTED BY	David Liu		

ANTENNA POLARITY & TEST DISTANCE: VERTICAL AT 3 M

No.	Freq. (MHz)	Emission Level (dBuV/m)	Limit (dBuV/m)	Margin (dB)	Antenna Height (cm)	Table Angle (Degree)	Raw Value (dBuV)	Correction Factor (dB/m)
1	107.7	35.40 PK	67.90	-32.50	130	360	23.69	11.71
2	107.7	31.40 AV	47.90	-16.50	130	360	19.69	11.71

- REMARKS:**
1. Emission level(dBuV/m)=Raw Value(dBuV) + Correction Factor(dB/m)
 2. Correction Factor(dB/m) = Antenna Factor (dB/m) + Cable Factor (dB)
 3. The other emission levels were very low against the limit.
 4. Margin value = Emission level – Limit value.



BUREAU
VERITAS

Test Report No.: FC110812N023

FCC ID ZXNLEETACEZ250

2.2.8 TEST RESULTS (30-2000MHZ)

TEST MODE	MP3 Playing mode Low channel	MODEL NO.	E-Z250
INPUT POWER (SYSTEM)	DC 7.5V from input 120V 60Hz	FREQUENCY RANGE	30-2000 MHz
ENVIRONMENTAL CONDITIONS	25 deg. C, 55% RH,	DETECTOR FUNCTION & BANDWIDTH	Quasi-Peak,120 kHz Above 1GHz Peak and Average,1MHz
TESTED BY	David Liu		

ANTENNA POLARITY & TEST DISTANCE: HORIZONTAL AT 3 M

No.	Freq. (MHz)	Emission Level (dBuV/m)	Limit (dBuV/m)	Margin (dB)	Antenna Height (cm)	Table Angle (Degree)	Raw Value (dBuV)	Correction Factor (dB/m)
1	131.04	7.14	43.50	-36.36	176	247	-5.54	12.68
2	136.78	14.90	43.50	-28.60	218	336	1.99	12.91
3	141.92	7.30	43.50	-36.20	100	100	-5.49	12.79
4	176.58	21.54	43.50	-21.96	212	240	11.05	10.49
5	264.93	22.48	46.00	-23.52	125	0	8.17	14.31
6	441.51	24.04	46.00	-21.96	100	153	4.74	19.30

TEST MODE	MP3 Playing Mode Low channel	MODEL NO.	E-Z250
INPUT POWER (SYSTEM)	DC 7.5V from input 120V 60Hz	FREQUENCY RANGE	30-2000 MHz
ENVIRONMENTAL CONDITIONS	25 deg. C, 55% RH, 101.52 kPa	DETECTOR FUNCTION & BANDWIDTH	Quasi-Peak,120 kHz Above 1GHz Peak and Average,1MHz
TESTED BY	David Liu		

ANTENNA POLARITY & TEST DISTANCE: VERTICAL AT 3 M

No.	Freq. (MHz)	Emission Level (dBuV/m)	Limit (dBuV/m)	Margin (dB)	Antenna Height (cm)	Table Angle (Degree)	Raw Value (dBuV)	Correction Factor (dB/m)
1	127.00	5.98	43.50	-37.52	398	335	-6.55	12.53
2	136.81	19.03	43.50	-24.47	100	1	6.12	12.91
3	176.56	17.32	43.50	-26.18	295	333	6.82	10.50
4	264.88	16.18	46.00	-29.82	398	335	1.87	14.31
5	372.43	18.44	46.00	-27.56	398	335	1.22	17.22
6	439.94	26.49	46.00	-19.51	398	335	7.22	19.27

- REMARKS:**
1. Emission level(dBuV/m)=Raw Value(dBuV) + Correction Factor(dB/m)
 2. Correction Factor(dB/m) = Antenna Factor (dB/m) + Cable Factor (dB)
 3. The other emission levels were very low against the limit.
 4. Margin value = Emission level – Limit value.

Bureau Veritas Shenzhen Co., Ltd.
Dongguan Branch

No. 34, Chenwulu Section, Guantai Rd., Houjie
Town, Dongguan City,
Guangdong 523942, China

Tel.: +86 769 8593 5656
Fax: +86 769 8593 1080
Email: customerservice.dg@cn.bureauveritas.com



**BUREAU
VERITAS**

Test Report No.: FC110812N023

FCC ID ZXNLEETACEZ250

TEST MODE	MP3 Playing, Middle channel	MODEL NO.	E-Z250
INPUT POWER (SYSTEM)	DC 7.5V from input 120V 60Hz	FREQUENCY RANGE	30-2000 MHz
ENVIRONMENTAL CONDITIONS	25 deg. C, 55% RH,	DETECTOR FUNCTION & BANDWIDTH	Quasi-Peak,120 kHz Above 1GHz Peak and Average,1MHz
TESTED BY	David Liu		

ANTENNA POLARITY & TEST DISTANCE: HORIZONTAL AT 3 M

No.	Freq. (MHz)	Emission Level (dBuV/m)	Limit (dBuV/m)	Margin (dB)	Antenna Height (cm)	Table Angle (Degree)	Raw Value (dBuV)	Correction Factor (dB/m)
1	70.86	1.38	40.00	-38.62	100	0	-5.13	6.51
2	133.71	6.55	43.50	-36.95	146	0	-6.30	12.85
3	196.61	33.08	43.50	-10.42	208	355	23.61	9.47
4	294.92	27.53	46.00	-18.47	100	119	12.87	14.66
5	398.41	12.66	46.00	-33.34	100	0	-5.32	17.98
6	491.52	27.76	46.00	-18.24	100	0	7.22	20.54

TEST MODE	MP3 Playing,Middle channel	MODEL NO.	E-Z250
INPUT POWER (SYSTEM)	DC 7.5V from input 120V 60Hz	FREQUENCY RANGE	30-2000 MHz
ENVIRONMENTAL CONDITIONS	25 deg. C, 55% RH,	DETECTOR FUNCTION & BANDWIDTH	Quasi-Peak,120 kHz Above 1GHz Peak and Average,1MHz
TESTED BY	David Liu		

ANTENNA POLARITY & TEST DISTANCE: VERTICAL AT 3 M

No.	Freq. (MHz)	Emission Level (dBuV/m)	Limit (dBuV/m)	Margin (dB)	Antenna Height (cm)	Table Angle (Degree)	Raw Value (dBuV)	Correction Factor (dB/m)
1	49.10	5.89	40.00	-34.11	222	0	-3.35	9.24
2	138.37	9.24	43.50	-34.26	199	0	-3.64	12.88
3	196.59	27.18	43.50	-16.32	155	317	17.71	9.47
4	226.31	4.11	46.00	-41.89	116	0	-6.96	11.07
5	380.87	10.87	46.00	-35.13	103	0	-6.55	17.42
6	491.45	16.96	46.00	-29.04	178	196	-3.58	20.54

- REMARKS:**
1. Emission level(dBuV/m)=Raw Value(dBuV) + Correction Factor(dB/m)
 2. Correction Factor(dB/m) = Antenna Factor (dB/m) + Cable Factor (dB)
 3. The other emission levels were very low against the limit.
 4. Margin value = Emission level – Limit value.

**Bureau Veritas Shenzhen Co., Ltd.
Dongguan Branch**

No. 34, Chenwulu Section, Guantai Rd., Houjie
Town, Dongguan City,
Guangdong 523942, China

Tel.: +86 769 8593 5656
Fax: +86 769 8593 1080
Email: customerservice.dg@cn.bureauveritas.com



BUREAU
VERITAS

Test Report No.: FC110812N023

FCC ID ZXNLEETACEZ250

TEST MODE	MP3 Playing Highest channel	MODEL NO.	E-Z250
INPUT POWER (SYSTEM)	MP3 Playing Mode Highest channel	FREQUENCY RANGE	30-2000 MHz
ENVIRONMENTAL CONDITIONS	25 deg. C, 55% RH,	DETECTOR FUNCTION & BANDWIDTH	Quasi-Peak,120 kHz Above 1GHz Peak and Average,1MHz
TESTED BY	David Liu		

ANTENNA POLARITY & TEST DISTANCE: HORIZONTAL AT 3 M								
No.	Freq. (MHz)	Emission Level (dBuV/m)	Limit (dBuV/m)	Margin (dB)	Antenna Height (cm)	Table Angle (Degree)	Raw Value (dBuV)	Correction Factor (dB/m)
1	155.00	25.20	43.50	-18.30	397	158	12.50	12.71
2	215.00	31.79	43.50	-11.71	328	212	20.40	11.39
3	296.00	27.75	46.00	-18.25	292	239	12.30	15.45
4	458.00	30.74	46.00	-15.26	256	267	10.20	20.54
5	537.53	33.12	46.00	-12.88	250	305	10.80	22.32
6	755.00	28.07	46.00	-17.93	263	349	2.35	25.72

TEST MODE	MP3 Playing Mode Highest channel	MODEL NO.	E-Z250
INPUT POWER (SYSTEM)	DC 7.5V from input 230V 50Hz	FREQUENCY RANGE	30-2000 MHz
ENVIRONMENTAL CONDITIONS	25 deg. C, 55% RH,	DETECTOR FUNCTION & BANDWIDTH	Quasi-Peak,120 kHz Above 1GHz Peak and Average,1MHz
TESTED BY	David Liu		

ANTENNA POLARITY & TEST DISTANCE: VERTICAL AT 3 M								
No.	Freq. (MHz)	Emission Level (dBuV/m)	Limit (dBuV/m)	Margin (dB)	Antenna Height (cm)	Table Angle (Degree)	Raw Value (dBuV)	Correction Factor (dB/m)
1	143.58	22.27	43.50	-21.23	120	22	8.90	13.37
2	225.94	22.87	46.00	-23.13	120	22	10.50	12.37
3	268.50	25.47	46.00	-20.53	100	112	10.56	14.91
4	397.00	25.73	46.00	-20.27	100	122	6.80	18.93
5	550.55	27.92	46.00	-18.08	100	22	5.36	22.56
6	644.50	26.44	46.00	-19.56	120	112	2.30	24.14

- REMARKS:**
1. Emission level(dBuV/m)=Raw Value(dBuV) + Correction Factor(dB/m)
 2. Correction Factor(dB/m) = Antenna Factor (dB/m) + Cable Factor (dB)
 3. The other emission levels were very low against the limit.
 4. Margin value = Emission level – Limit value.

Bureau Veritas Shenzhen Co., Ltd.
Dongguan Branch

No. 34, Chenwulu Section, Guantai Rd., Houjie
Town, Dongguan City,
Guangdong 523942, China

Tel.: +86 769 8593 5656
Fax: +86 769 8593 1080
Email: customerservice.dg@cn.bureauveritas.com



BUREAU VERITAS

Test Report No.: FC110812N023

FCC ID ZXNLEETACEZ250

2.3 20 dB BANDWIDTH

2.3.1 TEST LIMITS

No requirement.

2.3.2 TEST PROCEDURE

1. The EUT was placed on a table which is 0.8m above ground plane.
2. Connect EUT RF output port to the spectrum analyzer through an RF attenuator.
3. Set SA Center Frequency = Operation frequency, RBW=10kHz,VBW=30kHz.
4. Set SA trace max hold, then view.

2.3.3 TEST RESULT (PASS)

Frequency MHz	20dB bandwidth kHz
88.3	111.80
97.9	187.60
107.7	165.70

The test plots as following:

88.3MHz

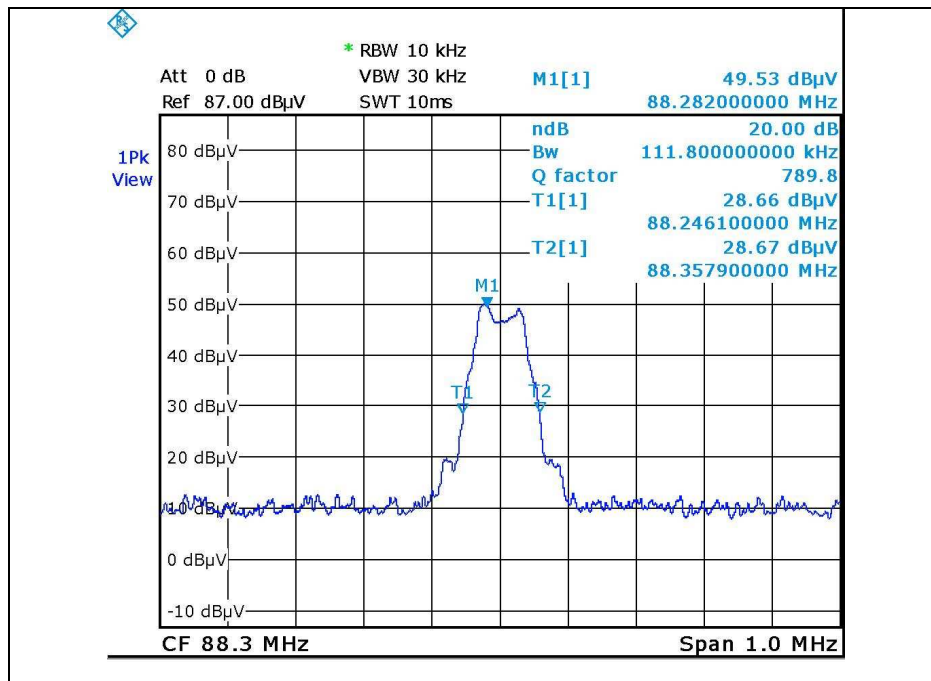

Bureau Veritas Shenzhen Co., Ltd.
Dongguan Branch

No. 34, Chenwulu Section, Guantai Rd., Houjie
Town, Dongguan City,
Guangdong 523942, China

Tel.: +86 769 8593 5656
Fax: +86 769 8593 1080
Email: customerservice.dg@cn.bureauveritas.com



BUREAU VERITAS

Test Report No.: FC110812N023

FCC ID ZXNLEETACEZ250

97.9MHz

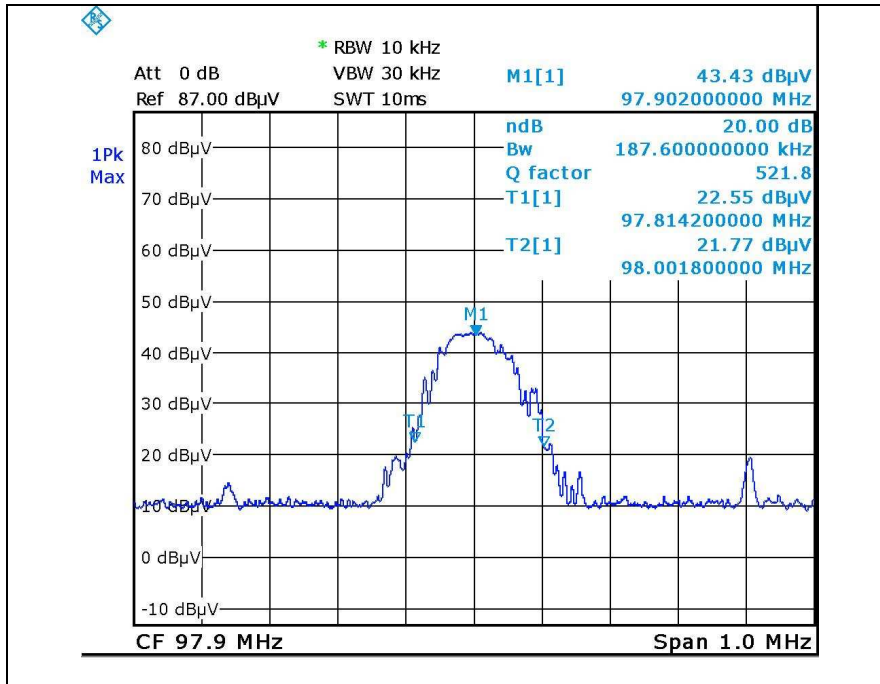

107.7.0MHz

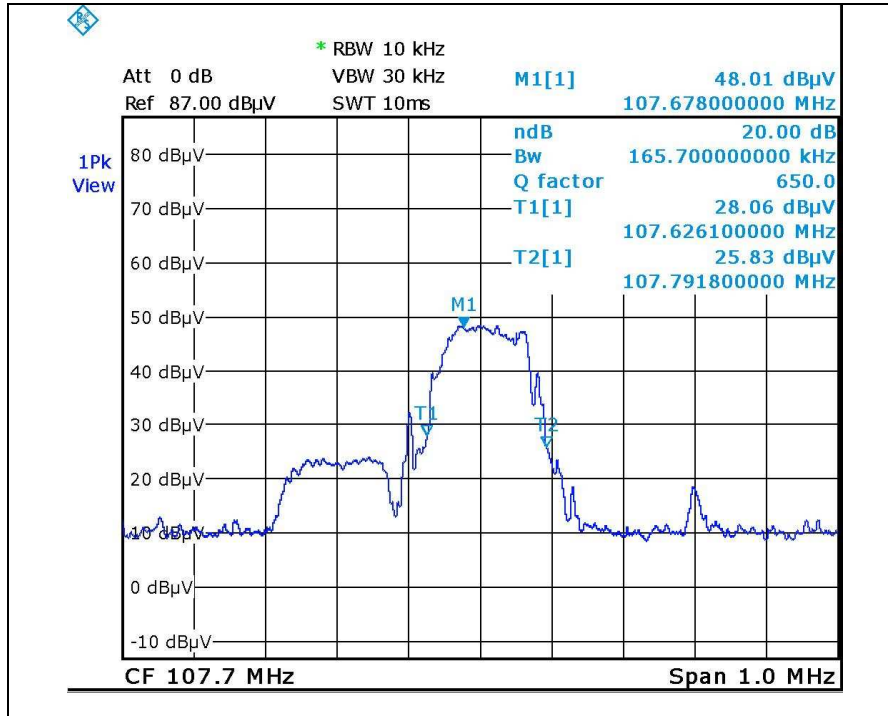

Bureau Veritas Shenzhen Co., Ltd.
Dongguan Branch

No. 34, Chenwulu Section, Guantai Rd., Houjie
Town, Dongguan City,
Guangdong 523942, China

Tel.: +86 769 8593 5656
Fax: +86 769 8593 1080
Email: customerservice.dg@cn.bureauveritas.com



**BUREAU
VERITAS**

Test Report No.: FC110812N023

FCC ID ZXNLEETACEZ250

3 PHOTOGRAPHS OF TEST CONFIGURATION

Please test setup photo to file.

**Bureau Veritas Shenzhen Co., Ltd.
Dongguan Branch**

No. 34, Chenwulu Section, Guantai Rd., Houjie
Town, Dongguan City,
Guangdong 523942, China

Tel.: +86 769 8593 5656
Fax: +86 769 8593 1080
Email: customerservice.dg@cn.bureauveritas.com



**BUREAU
VERITAS**

Test Report No.: FC110812N023

FCC ID ZXNLEETACEZ250

4 APPENDIX A – MODIFICATIONS RECORDERS FOR ENGINEERING CHANGES TO THE EUT BY THE LAB

No any modifications were made to the EUT by the lab during the test.

---END---