

Operating Manual

Model: E-5209

CD SHELF SYSTEM



CONTENT

INTRODUCTION	3
IMPORTANT SAFETY INSTRUCTIONS.....	3
SAFETY INFORMATIONS.....	4
BEFORE USE	5
BEWARE OF CONDENSATION	5
BUTTONS AND CONTROLS	6
REMOTE CONTROL UNIT.....	2
GET STARTED.....	3
CONNECTING EXTERNAL SPEAKERS.....	3
PRELIMINARY.....	3
LISTENING TO THE RADIO	3
ADJUSTING THE VOLUME.....	4
LISTENING TO A CD DISC.....	4
DISCS MAINTENANCE	5
AUX IN OPERATION	7
USING THE REMOTE CONTROL.....	8
TROUBLESHOOTING GUIDE.....	9
SPECIFICATIONS.....	10

INTRODUCTION

Thank you for buying this product.

To help you to have more fun when using this product, read these instructions thoroughly.

And then save this instruction manual for future reference.

IMPORTANT SAFETY INSTRUCTIONS

1. Read these instructions – All the safety and operating instructions should be read before this product is operated.
2. Keep these instructions- The safety and operating instructions should be retained for future reference.
3. Heed all warnings – All warnings on the appliance and in the operating instructions should be adhered to.
4. Follow all instructions – All operating and use instructions should be followed.
5. Do not use this apparatus near water – The appliance should not be used near water or moisture – for example, in a wet basement or near a swimming pool, and the like.
6. Clean only with dry cloth.
7. Do not block any ventilation openings. Install in accordance with the manufacturer's instructions.
8. Do not install near any heat sources such as radiations, heat registers, stoves, or other apparatus (including amplifiers) that produce heat.
9. Do not defeat the safety purpose of the polarized or grounding plug. A polarized plug has two blades with one wider than the other. A grounding plug has two blades and a third grounding prong. The wide blade or the third prong is provided for your safety. If the provided plug does not fit into your outlet, consult an electrician for replacement of the obsolete outlet.
10. Protect the power cord from being walked on or pinched particularly at the plugs, convenience receptacles, and at the point where they exit from the apparatus.
11. Only use attachments/accessories specified by the manufacturer.
12. Use only with the cart, stand, tripod, bracket, or table specified by the manufacturer, or sold with the apparatus. When a cart or rack is used, use caution when moving the cart/apparatus combination to avoid injury from tip-over.
13. Unplug the apparatus during lightning storms or when unused for long periods of time.
14. Refer all servicing to qualified personnel. Servicing is required when the apparatus has been exposed to rain or moisture, does not operate normally, or has been dropped.
15. The mains plug is used as disconnect device, the disconnect device shall remain readily operable.
16. To reduce the risk of fire or electric shock, do not expose this apparatus to rain or moisture. The apparatus shall not be exposed to dripping or splashing and that no objects filled with liquids, such as vases, shall not be placed on apparatus.
17. The use of the equipment in moderate climate.
18. The battery shall not be exposed to excessive heat such as sunshine, fire or the like.



CAUTION

Danger of explosion if battery is incorrectly replaced. Replace only with the same or equivalent type.



DO NOT INGEST BATTERY, CHEMICAL BURN HAZARD

The remote control supplied with a coin/button cell battery. This product contains a coin/button cell battery. If the coin/button cell battery is swallowed, it can cause severe internal burns in just 2 hours and can lead to death.

Keep new and used batteries away from children. If the battery compartment does not close securely, stop using the product and keep it away from children.

If you think batteries might have been swallowed or placed inside any part of the body, seek immediate medical attention.



-This lightning flash with arrowhead symbol within an equilateral triangle is intended to alert the user to the presence of non-insulated “dangerous voltage” within the product’s enclosure that may be of sufficient magnitude to constitute a risk of electric shock.

-Warning: To reduce the risk of electric shock, do not remove cover (or back) as there are no user-serviceable parts inside. Refer servicing to qualified personnel.

-The exclamation point within and equilateral triangle is intended to alert the user to the presence of important operating and maintenance instructions in the literature accompanying the appliance.



This equipment is a Class II or double insulated electrical appliance. It has been designed in such a way that it does not require a safety connection to electrical earth.

SAFETY INFORMATIONS

1. In order to shut off the power to this product completely, unplug the power cord from the wall outlet. Be sure to unplug the unit if you do not intend to use it for an extended period of time such as a vacation.
2. Use of controls and adjustments or performance of procedures other than those specified herein may result in hazardous radiation exposure.
3. If this product develops trouble, contact a qualified service center, and do not use the product in a defective state.
4. **WARNING:** To reduce the risk of electric shock, this appliance has a polarized plug (one blade is wider than the other). This plug will fit in a polarized outlet only one way. If the plug does not fit fully in the outlet, reverse the plug. If it still does not fit, contact a qualified electrician to install the proper outlet. Do not modify the plug in any way.

BEFORE USE

1. Choose unit installation location carefully. Avoid placing it in direct sunlight or close to a source of heat. Also avoid locations subject to vibrations and excessive dust, cold or moisture. Keep away from sources that hum, such as transformers or motors.
2. Do not open the cabinet as this might result in damage to the circuitry or electrical shock, if a foreign object should get into the set, contact your dealer.
3. Be sure not to handle discs with dirty fingers. Never insert a disc that has a crack on the surface.
4. When removing the power plug from the wall outlet, always pull directly on the plug, never pull the cord.
5. To keep the laser pickup clean, do not touch it, and do not forget to close the disc tray.
6. Do not attempt to clean the unit with chemical solvents as this might damage the finish. Use a clean, dry cloth.
7. In order to shut off the power to this product completely, unplug the power cord from the wall outlet. Be sure to unplug the unit if you do not intend to use it for an extended period of time, such as a vacation.
8. Keep this manual in a safe place for future reference.

BEWARE OF CONDENSATION

When the player (or a compact disc) is moved from a cold to a warm place or is used after a sudden temperature change, there is a danger of condensation. Water vapor in the air could condense on the mechanism or the laser pickup. If droplets of water form on these parts, correct playback will be impossible because the laser cannot read the information from the disc correctly. To prevent this, if you are going to use the player in a condition where condensation could occur, you should leave the player for 1 or 2 hours after plugging it into an AC outlet depending on the amount of condensation. If this is done, the player will stabilize at the temperature of its surroundings.

BUTTONS AND CONTROLS

MAIN UNIT

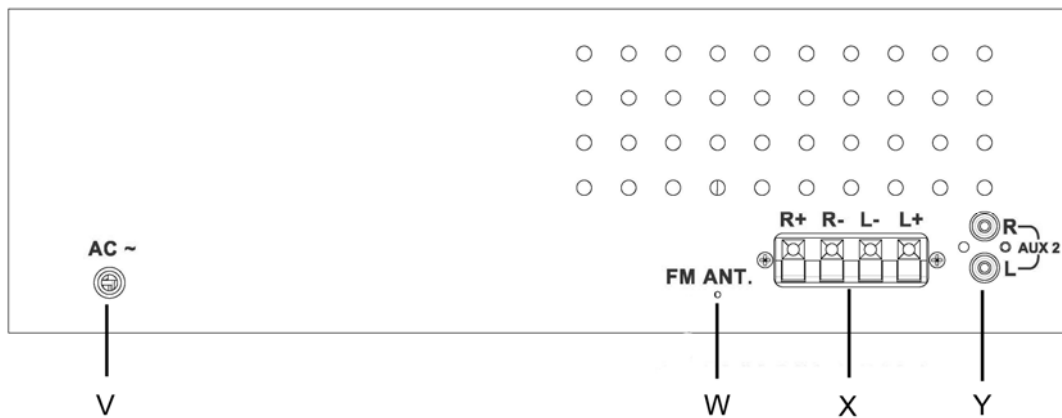
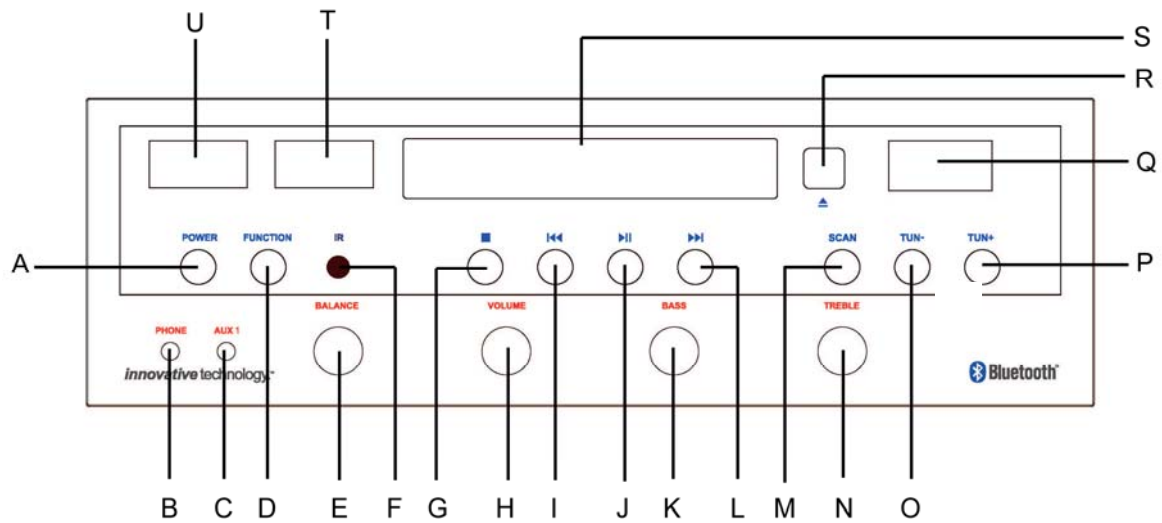

- | | |
|--|--|
| <p>A. POWER BUTTON</p> <p>B. PHONE SOCKET</p> <p>C. AUX IN 1 SOCKET</p> <p>D. FUNCTION BUTTON</p> <p>E. BALANCE KNOB</p> <p>F. IR</p> <p>G. ■ STOP BUTTON</p> <p>H. VOLUME KNOB</p> <p>I. ⏮ (PREVIOUS) BUTTON</p> <p>J. ▶⏪ PLAY/PAUSE BUTTON</p> <p>K. BASS KNOB</p> <p>L. ⏭ (NEXT) BUTTON</p> <p>M. SCAN BUTTON</p> | <p>N. TREBLE KNOB</p> <p>O. TUNING DOWN BUTTON</p> <p>P. TUNING UP BUTTON</p> <p>Q. DISPLAY</p> <p>R. ▲ EJECT/ENTER BUTTON</p> <p>S. CD COMPARTMENT</p> <p>T&U. DISPLAY OF VOLUME</p> <p>V. AC POWER CORD</p> <p>W. FM ANTENNA</p> <p>X. SPEAKER INPUT SOCKET (LEFT&RIGHT)</p> <p>Y. AUX IN 2 SOCKET (L/R)</p> |
|--|--|

REMOTE CONTROL UNIT

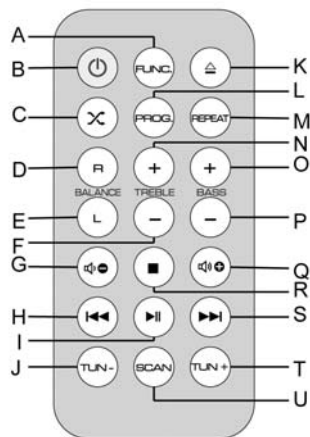

A. FUNCTION BUTTON: Select a source.

B. ON/STANDBY BUTTON: Set the unit ON or STANDBY.

C. RANDOM: Select to a random playback.

D. BALANCE (RIGHT): Select the right speaker to adjust treble or bass

E. BALANCE (LEFT): Select the left speaker to adjust treble or bass

F & N. TREBLE(+/-): Act as "up" or "down"treble

G&Q. VOLUME + / - BUTTON: Adjust the volume level.

H&S. ⏭ (NEXT) BUTTON/⏮ (PREVIOUS) BUTTON: skip backward or forward.

I. PLAY/PAUSE BUTTON: Pause and resume playback.

J&T. TUN-/TUN+: in the FM mode, adjust the frequency.

K. EJECT/ENTER: In CD mode, eject and close the CD Tray.

L. PROGRAM:Set a program playback.

M. REPEAT: set a repeat playback

O&P. BASS (+/-): Act as "up" or "down"bass.

R. ■ (STOP) BUTTON: Stop the playback.

U. SCAN: Act as " scan" in the menu.

GET STARTED

CONNECTING EXTERNAL SPEAKERS

The speaker input sockets locate at the back of the main unit.

Unwrap the speaker wire from the left speaker and plug it into the left (L) speaker socket on the main unit.

Unwrap the speaker wire from the right speaker and plug it into the right (R) speaker socket on the main unit.

Make sure the speaker cables will not run in areas where they could cause danger.

PRELIMINARY

Before connecting power to your audio system, the protective packing should be removed from the CD compartment.

To remove the protective packing:

Press the FUNCTION button to select CD function.

Press the EJECT/ENTER button at the front corner to open the CD door.

Remove the protective packing from the CD compartment.

Close the CD door by pressing the EJECT/ENTER button to latch it shut.

FM ANTENNA

Unwrap the FM antenna and extend it fully. You may need to adjust the position of the antenna to get optimum reception.

CONNECTING THE POWER

Check that the mains voltage in the rating plate on the back of the main unit is the same as the voltage in your area.

Plug the electric plug into the wall socket. Now the audio system is ready for use.

STANDBY CONTROL

To turn the main unit on:

Press the POWER button. The unit will turn on.

To turn the power off:

Press the POWER button to turn the unit off.

NOTE: When leaving the unit unattended for long period (such as holidays), please disconnect the power plug from the mains supply.

LISTENING TO THE RADIO

1. Press the FUNCTION BUTTON to Switch to FM RADIO function and the display will show "FM".

2. Tune to a desired radio station. The frequency is indicated on the display.

MANUAL TUNING: Press the **TUNING +** or **TUNING -** button briefly and the frequency will be tuning up or down at a step.

AUTO SEARCHING: Press the **TUNING +** or **TUNING -** button for more than 2 seconds, radio frequency will start to change on the display. Once a station is found, the radio will stop searching, the display will show "ST" and start to broadcast immediately.

3. Re-position the antenna if necessary.

ADJUSTING THE VOLUME

VOLUME ADJUSTMENT

Twist the VOLUME KNOB to adjust the volume

The volume setting will be displayed briefly on a scale display on the left upper corner of the unit.

BALANCE

Twist the Balance Knob to adjust the volume between the left speaker and the right speaker. The volume of the left speaker and right speaker is equal when the LED display shows "00" by switching the balance knob.

TREBLE and BASS

Twist the Treble Knob and the Bass Knob to switch between treble and bass from "-3" to "3"

LISTENING TO A CD DISC

PRELIMINARIES:

- Press **FUNCTION** button repeatedly to select CD function and the display will show "CD".
- Press the **EJECT/ENTER** button to open the CD door, put a CD disc on the CD compartment with printed label facing upside (towards you). Close the CD door and press **EJECT/ENTER** button again to latch it shut.

TO PLAY A CD WHEN STOPPED: Press the PLAY/PAUSE button. The disc will play from track 1.

TO PAUSE A CD WHILE PLAYING: Press the PLAY/PAUSE button. The disc will pause and pause indicator appears on the display. Press the PLAY/PAUSE button again to resume the playback.

TO STOP A CD WHILE PLAYING: Press the **STOP** button.

TO CHANGE TRACKS: Press **◀** (PREVIOUS) BUTTON or **▶** (NEXT) BUTTON.

TO SEARCH FOR A PARTICULAR PART DURING PLAY: Press and hold **◀** (PREVIOUS) BUTTON or **▶** (NEXT) BUTTON until the desired part is located. During searching the sound will be played at distorted speed. Play returns to normal when the button is released.

REPEATING/RANDOM PLAYBACK A TRACK OR A CD:

Press **REPEAT** button on the remote control to circle the play mode:

- Repeat 1---Press REPEAT button on the remote control once and the current track will be continuously played.
- Repeat all---Press REPEAT button again and All tracks on the current disc will be played continuously.
- Normal playback --- Press **REPEAT** button again to resume normal playback.

Note: Press **STOP** button the disc will stop playing and the play mode will be clear.

PROGRAM PLAY:

Program play must be set when the CD is stopped. You can program up-to-20 tracks in any order.

1. Press **STOP** button and then press **PROGRAM** button on the remote control.

2. Press **▶▶ (NEXT) BUTTON/◀◀ (PREVIOUS) BUTTON** to select a track.
The display shows the selected track.

3. Press the **PROGRAM** button on the remote control to add the track into the program list.

4. Repeat steps 2 and 3 to till you accomplish the programming.
You can program up to 20 tracks.

TO START THE PROGRAM PLAY

Press **PLAY/PAUSE** button.

TO PAUSE OR STOP A PROGRAM PLAY

Press **PLAY/PAUSE** or **STOP** button.

TO REPLAY A PROGRAM

Press **PLAY/PAUSE** button.

TO REVIEW THE CONTENT OF A PROGRAM

Press **STOP** button then keep pressing the **PROGRAM** button to review the programmed tracks.

TO CLEAR THE PRORAM

Press **STOP** button twice and the "PROG" will disappear from the display.

Open and close the CD door to clear the program play.

After play, remove the CD.

DISCS MAINTENANCE

Depending on the quality of the disc and the condition of the recording, some CD-R/CD-RW disc may not be playable.

1. Always place the compact disc in the disc tray with the label facing upward. (Compact discs can be played only on one side).



How to remove the disc



How to hold the disc

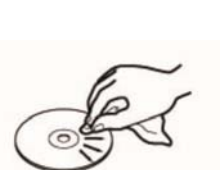

2. To move a disc from its storage case, press down on the center of the case and lift the disc out, holding it carefully by the edges.

3. If the disc becomes dirty, wipe the surface from the center hole outward towards the outer edge with a soft, dry cloth.
4. Never use such chemicals as record spray, antistatic sprays or fluid, benzine or thinner to clean the discs. Such chemicals will do irreparable damage to the disc's plastic surface.
5. Discs should be returned to their cases after use to avoid serious scratches that could cause the laser pick up to skip.
6. Do not expose discs to direct sunlight or high humidity and temperature for extend periods. Long exposure to high temperatures will warp the disc.
7. Printable CD-R and CD-RW discs are not recommended, as the label side might be sticky and damage the unit.
8. Use a soft oil-based felt-tipped pen to write the information on the label side. Never use a ball-point or hard-tipped pen, as this may cause damage to the recorded side.
9. Do not use CDs with an irregular shape (octagonal, heart-shaped, business card size, etc).CDs of this sort can damage the unit.
10. If you have any doubts of using CD-R/CD-RW disc, read the precautions supplied with the disc, or contact the disc manufacture directly.

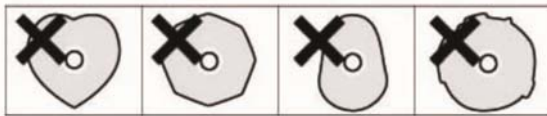

AUX IN OPERATION

Any external (auxiliary) audio source (i.e., personal CD player or MP3 player) connected to this appliance can get necessary signal and channel the speaker outputs.

The unit has 2 AUX INs. AUX IN 1 SOCKET at the front of the unit, AUX IN 2 SOCKET at the rear of the unit.

1. Press **POWER** button to turn the unit ON and then press **FUNCTION** button to select "AUX1" or "AUX2".
2. Set the volume level to the minimum level with the **VOLUME KNOB**.
3. Plug the AUX IN cable (not included) into the AUX IN socket at the unit.
 - For AUX IN 2 SOCKET, plug one end of the AUX IN cable (included) into the color coded AUX IN sockets at rear of the unit. Always make sure the white plug is connected to the white socket and the red plug in the red socket.
4. Plug the other end of the cable into the headphone or Line Out socket of the external source.
5. Turn on the external audio device and set it play. Turn the external audio device's volume up to 2/3. If necessary adjust the volume on the unit by switching the volume knob.

BLUETOOTH CONNECTIVITY

External devices which have a built-in Bluetooth feature can be connected to this apparatus and play through the speakers.

GETTING CONNECTED

1. Press **FUNCTION** button to select Bluetooth function and then the display shows "BLUE" and "📶".
2. Set the Bluetooth function of your external device ON.
3. Set to search Bluetooth device on your external device.
NOTE: The effective distance between your external device and this apparatus is 10 meters.
5. Wait for a while then find the "ITCDS-5000a" on the paired devices list on your external device.
6. If a window asks you a password. Fill in "0000" or "1234" then press "OK" on your external device.
7. A beep sound should be heard that indicates a connection has been established.
8. A few seconds later your Bluetooth connection should be achieved.

ENJOY MUSIC FROM AN EXTERNAL DEVICE

1. Get your external device paired. (See "Getting connected")
 2. Turn on the music player program on your external device and set it play.
- Normally, you can control music playback with the PLAY/PAUSE, ⏪ and ⏩ button on the apparatus. However, some buttons may not work due to the variable music player program.
- Now enjoy the fun.

USING THE REMOTE CONTROL

The Remote Control Unit can operate the unit from a distance. When operating the remote control unit, point it towards the front panel of the unit.

- Even if the remote control unit is operated within the effective range, remote control operation may be impossible if there are any obstacles between the unit and the remote control.
- If the remote control unit is operated near other appliances which generate infrared rays, or if other remote control devices using infrared rays are used near the unit, it may operate incorrectly. Conversely, the other appliances may operate incorrectly.

TO ACTIVATE THE REMOTE CONTROL:

The remote control is built with cell battery before shipment. To activate the battery, remove the transparent plate at the bottom of the remote control.

Now the remote control is ready to use.

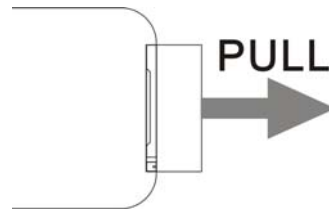

BATTERY REPLACEMENT: If the distance required between the remote control unit and main unit decreases, the battery is exhausted. In this case, please replace the battery with new one.

TO REPLACE WITH A NEW BATTERY:

1. Remove the battery compartment cover as per illustration on the right.
2. Observing the correct polarity and put a 3Vdc lithium battery (CR2025).
3. Close the cover.

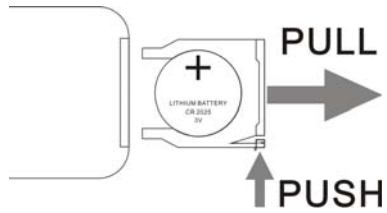

Battery Precautions:

- Be sure to insert the battery with correct positive + and negative - polarities.
- Refer to the precautions on the battery labels.
- When the remote control unit is not to be used for a long time (more than a month), remove the battery from the remote control unit to prevent it from leaking. If it leaks, wipe away the liquid inside the battery compartment and replace the battery with new one.
- Do not heat or disassemble batteries and never dispose of old batteries by throwing them in a fire.

TROUBLESHOOTING GUIDE

In case of trouble with the unit, please look through problems below and see if you can solve them yourself before calling your dealer.

	Problem	Cause	Solution
THE WHOLE UNIT	Power does not come on when the power switch is pressed.	<ul style="list-style-type: none"> • Unit is unplugged. 	<ul style="list-style-type: none"> • Connect the unit to the AC power supply.
	No sound comes out of the speakers.	<ul style="list-style-type: none"> • The external speakers are disconnected. • The volume is turned down (to MIN). • The input selector does not match the playback source. 	<ul style="list-style-type: none"> • Connect the external speakers. • Adjust the volume. • Re-select the desired input source.
	The sound is noisy.	<ul style="list-style-type: none"> • The unit is too close to a TV set or another similar appliance. 	<ul style="list-style-type: none"> • Turn off the TV or other appliance, and relocate the unit.
	The unit does not act as expected, or respond.	<ul style="list-style-type: none"> • External factors such as ESD (Electro-static discharge) affect the unit. 	<ul style="list-style-type: none"> • Remove the power cord and all power supply devices. Then re-plug the unit after one minute.
TUNER UNIT	Cannot listen to any station, or signal appears weak.	<ul style="list-style-type: none"> • The station is not tuned-in properly. • A TV set is being used nearby and is interfering with the radio reception. 	<ul style="list-style-type: none"> • Properly tune-in the desired station. • Turn-off the interfering TV set.
	The sound is distorted.	<ul style="list-style-type: none"> • The antenna is not positioned properly. 	<ul style="list-style-type: none"> • Re-position the antenna until reception improves.
CD PLAYER	CD stops immediately after starting, or unit pauses or stops during play.	<ul style="list-style-type: none"> • The CD is inserted upside down. • The CD is dusty or dirty or there is condensation on the CD. 	<ul style="list-style-type: none"> • Insert the CD with the printed side right-side up. • Carefully clean and dry the CD.
	No sound.	<ul style="list-style-type: none"> • The CD player is paused. 	<ul style="list-style-type: none"> • Press the PLAY/PAUSE button.
	Specific CD is noisy, or playback stops or skips.	<ul style="list-style-type: none"> • The CD is scratched, damaged or warped. • The disc is very dirty. 	<ul style="list-style-type: none"> • The CD should be changed. • Carefully clean the CD.

SPECIFICATIONS

AMPLIFIER section

Output Power	25W + 25W
Frequency Response	60 to 20, 000 Hz

TUNER section

FM Section		
Frequency Range	87.5 to 108 MHz

CD PLAYER section

Frequency Response	60 to 20, 000 Hz
Signal-to-Noise Ratio	55 dB (IEC-A)

SPEAKER SYSTEM section

Impedance	8ohms
Input Power	Max. 30W

GENERAL

Power Requirements	AC 120V ~ 60Hz
Power Consumption	60W
Dimensions (L x D x H)	360mm x222mm x 110mm (approx.)
Loudspeakers Dimensions (L x D x H)	130mm x217.5mm x 250mm (approx.)
Weight	5.53 kgs (approx.)
Standard Accessories	Operating Instruction Booklet; Remote control with battery; A pair of external speakers;

NOTE: As a result of continual improvements, the design and specifications of this product are subject to change without notice.

FCC STATEMENT

Warning: Changes or modifications to this unit not expressly approved by the party responsible for compliance could void the user's authority to operate the equipment.

NOTE: This equipment has been tested and found to comply with the limits for a Class B digital device, pursuant to part 15 of the FCC Rules. These limits are designed to provide reasonable protection against harmful interference in a residential installation. This equipment generates, uses and can radiate radio frequency energy and, if not installed and used in accordance with the instructions, may cause harmful interference to radio communications.

However, there is no guarantee that interference will not occur in a particular installation. If this equipment does cause harmful interference to radio or television reception, which can be determined by turning the equipment off and on, the user is encouraged to try to correct the interference by one or more of the following measures:

- Reorient or relocate the receiving antenna.
- Increase the separation between the equipment and the receiver.
- Connect the equipment into an outlet on a circuit different from that to which the receiver is connected.
- Consult the dealer or an experienced radio/TV technician for help.