



FCC RF Test Report

APPLICANT : Igluu LLC
EQUIPMENT : Digital Media Receiver
MODEL NAME : SK705DI
FCC ID : ZWJ-0823
STANDARD : FCC Part 15 Subpart E §15.407
CLASSIFICATION : (NII) Unlicensed National Information Infrastructure

The testing was completed on Apr. 15, 2016. We, SPORTON INTERNATIONAL INC., would like to declare that the tested sample has been evaluated in accordance with the test procedures and has been in compliance with the applicable technical standards.

The test results in this report apply exclusively to the tested model / sample. Without written approval of SPORTON INTERNATIONAL INC., the test report shall not be reproduced except in full.

Reviewed by: Joseph Lin / Supervisor

Approved by: Jones Tsai / Manager



SPORTON INTERNATIONAL INC.

No. 52, Hwa Ya 1st Rd., Hwa Ya Technology Park, Kwei-Shan District, Tao Yuan City, Taiwan, R.O.C.



TABLE OF CONTENTS

REVISION HISTORY..... 3

SUMMARY OF TEST RESULT 4

1 GENERAL DESCRIPTION 5

 1.1 Applicant 5

 1.2 Product Feature of Equipment Under Test..... 5

 1.3 Product Specification of Equipment Under Test..... 5

 1.4 Modification of EUT 6

 1.5 Testing Location 6

 1.6 Applicable Standards..... 7

2 TEST CONFIGURATION OF EQUIPMENT UNDER TEST 8

 2.1 Carrier Frequency and Channel 8

 2.2 Pre-Scanned RF Power 9

 2.3 Test Mode 10

 2.4 Connection Diagram of Test System 11

 2.5 Support Unit used in test configuration and system 12

 2.6 EUT Operation Test Setup 12

 2.7 Measurement Results Explanation Example..... 12

3 TEST RESULT 13

 3.1 6dB and 26dB and 99% Occupied Bandwidth Measurement 13

 3.2 Maximum Conducted Output Power Measurement 16

 3.3 Power Spectral Density Measurement 17

 3.4 Unwanted Emissions Measurement 19

 3.5 AC Conducted Emission Measurement..... 27

 3.6 Frequency Stability Measurement 31

 3.7 Automatically Discontinue Transmission 32

 3.8 Antenna Requirements 34

4 LIST OF MEASURING EQUIPMENT 35

5 UNCERTAINTY OF EVALUATION 36

APPENDIX A. CONDUCTED TEST RESULTS

APPENDIX B. RADIATED SPURIOUS EMISSION

APPENDIX C. RADIATED SPURIOUS EMISSION PLOTS



REVISION HISTORY

REPORT NO.	VERSION	DESCRIPTION	ISSUED DATE
FR273180-08	Rev. 01	Initial issue of report	Apr. 22, 2016
FR273180-08	Rev. 02	1. Update report of adding Chapter 3.7 test data. 2. This report (Report Number: FR273180-08) is to address the UNII new rules. U-NII-3 is retest, but the U-NII-1 RF power levels will not change, so no need to update U-NII-1 report as the original report is still valid. All the test cases were performed on original report which can be referenced in Report Number FR273180-04D.”	May 09, 2016



SUMMARY OF TEST RESULT

Report Section	FCC Rule	Description	Limit	Result	Remark
3.1	15.403(i)	6dB, 26dB and 99% Occupied Bandwidth	> 500kHz	Pass	-
3.2	15.407(a)	Maximum Conducted Output Power	≤ 30 dBm	Pass	-
3.3	15.407(a)	Power Spectral Density	≤ 30 dBm/500kHz	Pass	-
3.4	15.407(b)	Unwanted Emissions	≤ -17, -27 dBm/MHz & 15.209(a)	Pass	Under limit 0.87 dB at 5850.080 MHz
3.5	15.207	AC Conducted Emission	15.207(a)	Pass	Under limit 14.70 dB at 17.310 MHz
3.6	15.407(g)	Frequency Stability	Within Operation Band	Pass	-
3.7	15.407(c)	Automatically Discontinue Transmission	Discontinue Transmission	Pass	-
3.8	15.203 & 15.407(a)	Antenna Requirement	N/A	Pass	-



1 General Description

1.1 Applicant

Igluu LLC
830 Bear Tavern Road Suite 305 West Trenton, NJ 08628

1.2 Product Feature of Equipment Under Test

Product Feature	
Equipment	Digital Media Receiver
Model Name	SK705DI
FCC ID	ZWJ-0823
EUT supports Radios application	WLAN 11a/b/g/n HT20/HT40 Bluetooth v2.0 EDR

Remark: The above EUT's information was declared by manufacturer. Please refer to the specifications or user's manual for more detailed description.

1.3 Product Specification of Equipment Under Test

Standards-related Product Specification													
Tx/Rx Channel Frequency Range	5745 MHz ~ 5825 MHz												
Maximum Output Power	<p><Ant. 1> 802.11a : 17.95 dBm / 0.0624 W SISO <Ant. 1> 802.11n HT20 : 17.74 dBm / 0.0594 W 802.11n HT40 : 17.55 dBm / 0.0569 W MIMO <Ant. 1 + 2> 802.11n HT20 : 20.70 dBm / 0.1175 W 802.11n HT40 : 20.57 dBm / 0.1140 W</p>												
99% Occupied Bandwidth	802.11a : 18.20 MHz 802.11n HT20 : 24.20 MHz 802.11n HT40 : 40.70 MHz												
Type of Modulation	802.11a/n : OFDM (BPSK / QPSK / 16QAM / 64QAM)												
Antenna Type	Fixed Internal Antenna												
Antenna Gain	Main Antenna : 5.74 dBi Aux. Antenna : 4.30 dBi												
Antenna Function Description	<table border="1"> <thead> <tr> <th></th> <th>Ant. 1</th> <th>Ant. 2</th> </tr> </thead> <tbody> <tr> <td>802.11 a</td> <td>V</td> <td>-</td> </tr> <tr> <td>802.11 n</td> <td>V</td> <td>-</td> </tr> <tr> <td>802.11 n MIMO</td> <td>V</td> <td>V</td> </tr> </tbody> </table>		Ant. 1	Ant. 2	802.11 a	V	-	802.11 n	V	-	802.11 n MIMO	V	V
	Ant. 1	Ant. 2											
802.11 a	V	-											
802.11 n	V	-											
802.11 n MIMO	V	V											



1.4 Modification of EUT

No modifications are made to the EUT during all test items.

1.5 Testing Location

Sporton Lab is accredited to ISO 17025 by Taiwan Accreditation Foundation (TAF code : 1190) and the FCC designation No. TW1022 under the FCC 2.948(e) by Mutual Recognition Agreement (MRA) in FCC Test.

Test Site	SPORTON INTERNATIONAL INC.	
Test Site Location	No. 52, Hwa Ya 1 st Rd., Hwa Ya Technology Park, Kwei-Shan District, Tao Yuan City, Taiwan, R.O.C. TEL: +886-3-327-3456 FAX: +886-3-328-4978	
Test Site No.	Sporton Site No.	
	TH05-HY	CO05-HY

Note: The test site complies with ANSI C63.4 2014 requirement.

Test Site	SPORTON INTERNATIONAL INC.	
Test Site Location	No.58, Aly. 75, Ln. 564, Wenhua 3rd Rd. Guishan Dist, Taoyuan City, Taiwan (R.O.C.) TEL: +886-3-327-0868 FAX: +886-3-327-0855	
Test Site No.	Sporton Site No.	
	03CH10-HY	

Note: The test site complies with ANSI C63.4 2014 requirement.



1.6 Applicable Standards

According to the specifications of the manufacturer, the EUT must comply with the requirements of the following standards:

- ♦ FCC Part 15 Subpart E
- ♦ FCC KDB 789033 D02 General UNII Test Procedures New Rules v01r02
- ♦ FCC KDB 662911 D01 Multiple Transmitter Output v02r01.
- ♦ ANSI C63.10-2013

Remark: All test items were verified and recorded according to the standards and without any deviation during the test.



2 Test Configuration of Equipment Under Test

The EUT has been associated with peripherals and configuration operated in a manner tended to maximize its emission characteristics in a typical application. Frequency range investigated: conducted emission (150 kHz to 30 MHz) and radiated emission (9 kHz to the 10th harmonic of the highest fundamental frequency or to 40 GHz, whichever is lower).

The final configuration from all the combinations and the worst-case data rates were investigated by measuring the maximum power across all the data rates and modulation modes under section 2.2.

Based on the worst configuration found above, the RF power setting is set individually to meet FCC compliance limit for the final conducted and radiated tests shown in section 2.3.

2.1 Carrier Frequency and Channel

Frequency Band	Channel	Freq. (MHz)	Channel	Freq. (MHz)
5725-5850 MHz Band 4 (U-NII-3)	149	5745	157	5785
	151	5755	159	5795
	153	5765	161	5805
	155	5775	165	5825

Note: The above Frequency and Channel in boldface were 802.11n HT40.



2.2 Pre-Scanned RF Power

Preliminary tests were performed in different data rate and data rate associated with the highest power were chosen for full test in the following tables.

<Ant. 1>

5GHz 802.11a mode								
Data Rate (MHz)	6M bps	9M bps	12M bps	18M bps	24M bps	36M bps	48M bps	54M bps
Average Power (dBm)	17.95	17.77	17.66	17.52	17.69	17.66	17.57	17.73

SISO <Ant. Port 1>

5GHz 802.11n HT20 mode								
Data Rate (MHz)	MCS0	MCS1	MCS2	MCS3	MCS4	MCS5	MCS6	MCS7
Average Power (dBm)	17.74	17.67	17.70	17.61	17.58	17.63	17.59	17.56

5GHz 802.11n HT40 mode								
Data Rate (MHz)	MCS0	MCS1	MCS2	MCS3	MCS4	MCS5	MCS6	MCS7
Average Power (dBm)	17.55	17.45	17.45	16.62	16.54	16.54	16.58	16.47

MIMO <Ant. 1+2>

5GHz 802.11n HT20 mode								
Data Rate (MHz)	MCS 0	MCS 1	MCS 2	MCS 3	MCS 4	MCS 5	MCS 6	MCS 7
Average Power (dBm)	20.70	20.50	20.59	20.55	20.56	20.57	20.54	20.59

5GHz 802.11n HT40 mode								
Data Rate (MHz)	MCS 0	MCS 1	MCS 2	MCS 3	MCS 4	MCS 5	MCS 6	MCS 7
Average Power (dBm)	20.57	20.34	20.42	19.27	19.28	19.25	19.34	19.34

Note: MIMO Ant. 1+2 is a calculated result from sum of the power MIMO Ant. 1 and MIMO Ant. 2.



2.3 Test Mode

Final test mode of conducted test items and radiated spurious emissions are considering the modulation and worse data rates from the power table described in section 2.2.

Modulation	Data Rate
802.11a	6 Mbps
802.11n HT20	MCS0
802.11n HT40	MCS0

AC Conducted Emission	Mode 1 : WLAN (5G) Link + Adapter + MP3
------------------------------	---

Ch. #		Band IV : 5725-5850 MHz		
		802.11a	802.11n HT20	802.11n HT40
L	Low	149	149	151
M	Middle	157	157	-
H	High	165	165	159

2.4 Connection Diagram of Test System

<WLAN Tx Mode>

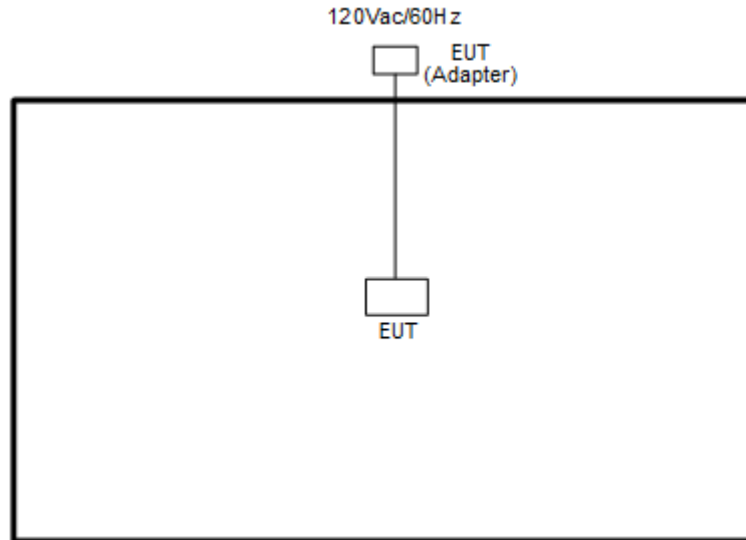

<AC Conducted Emission Mode>

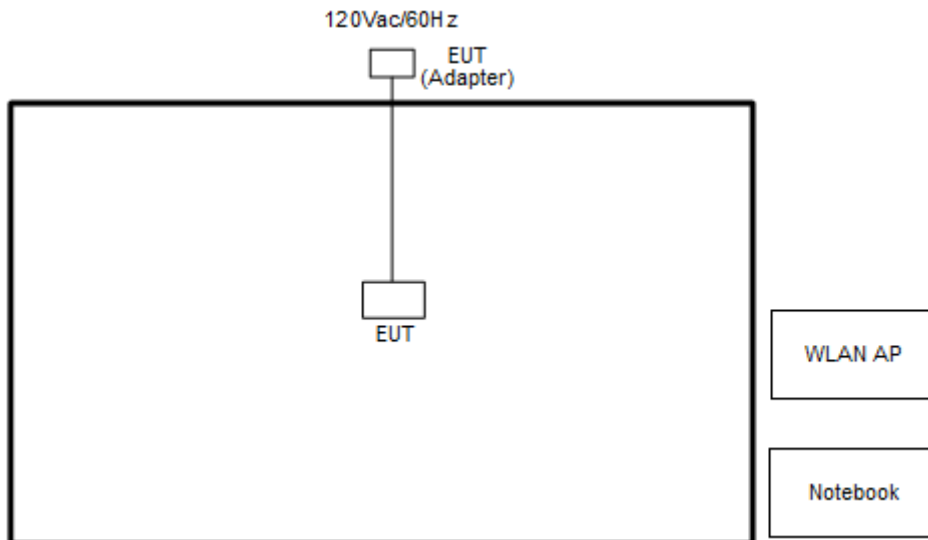



2.5 Support Unit used in test configuration and system

Item	Equipment	Trade Name	Model Name	FCC ID	Data Cable	Power Cord
1.	WLAN AP	D-Link	DIR-628	KA2DIR628A2	N/A	Unshielded, 1.8 m
2.	Notebook	DELL	Latitude E6320	FCC DoC	N/A	AC I/P: Unshielded, 1.2 m DC O/P: Shielded, 1.8 m

2.6 EUT Operation Test Setup

For WLAN function, programmed RF utility, "Putty tools" installed in the notebook make the EUT provide functions like channel selection and power level for continuous transmitting and receiving signals.

2.7 Measurement Results Explanation Example

For all conducted test items:

The offset level is set in the spectrum analyzer to compensate the RF cable loss and attenuator factor between EUT conducted output port and spectrum analyzer. With the offset compensation, the spectrum analyzer reading level is exactly the EUT RF output level.

Example :

The spectrum analyzer offset is derived from RF cable loss and attenuator factor.

Offset = RF cable loss + attenuator factor.

Following shows an offset computation example with cable loss 4.2 dB and 10dB attenuator.

$$\begin{aligned} \text{Offset(dB)} &= \text{RF cable loss(dB)} + \text{attenuator factor(dB)}. \\ &= 4.2 + 10 = 14.2 \text{ (dB)} \end{aligned}$$

3 Test Result

3.1 6dB and 26dB and 99% Occupied Bandwidth Measurement

3.1.1 Description of 6dB and 26dB and 99% Occupied Bandwidth

The minimum 6 dB bandwidth shall be at least 500 kHz.

26dB and 99% Occupied bandwidth are reporting only.

3.1.2 Measuring Instruments

The measuring equipment is listed in the section 4 of this test report.

3.1.3 Test Procedures

1. The testing follows FCC KDB 789033 D02 General UNII Test Procedures New Rules v01r02.
Section C) Emission bandwidth for the band 5.725-5.85GHz
2. Set RBW = 100kHz.
3. Set the VBW $\geq 3 \times$ RBW.
4. Detector = Peak.
5. Trace mode = max hold
6. Measure the maximum width of the emission that is 6 dB down from the peak of the emission.
7. Measure and record the results in the test report.

3.1.4 Test Setup



3.1.5 Test Result of 6dB and 26dB and 99% Occupied Bandwidth

Please refer to Appendix A.

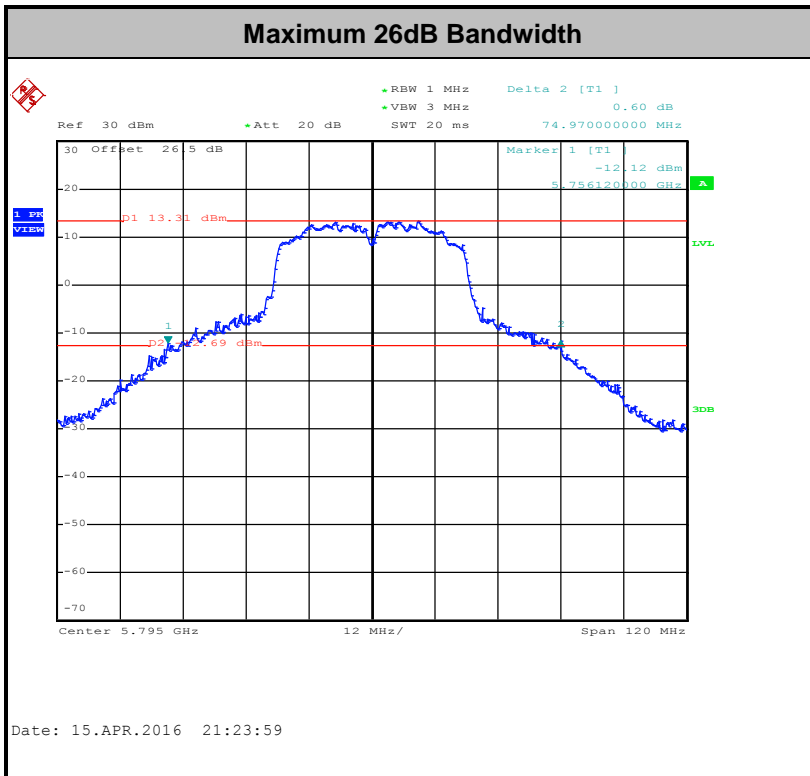
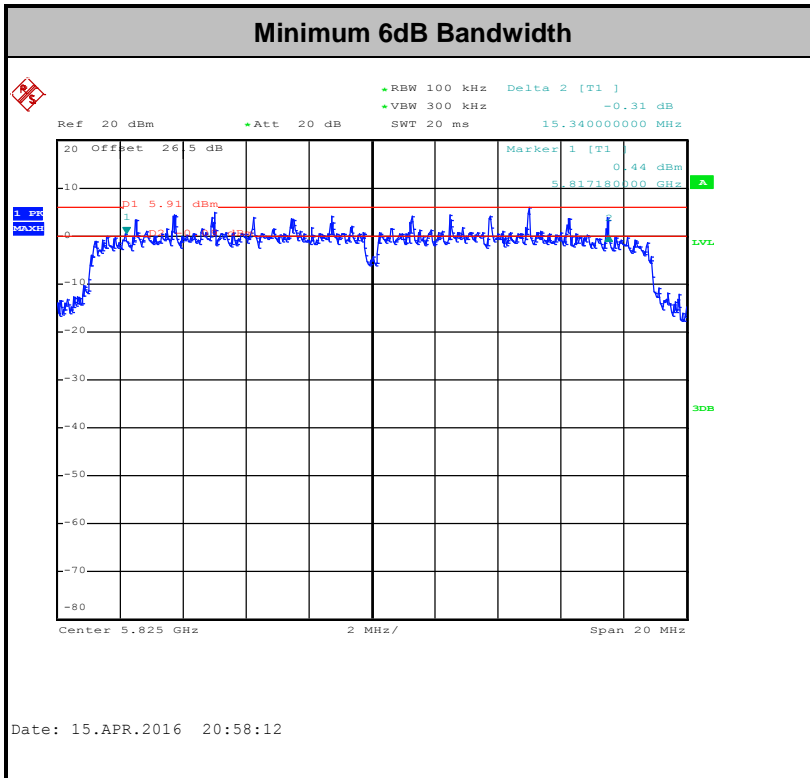

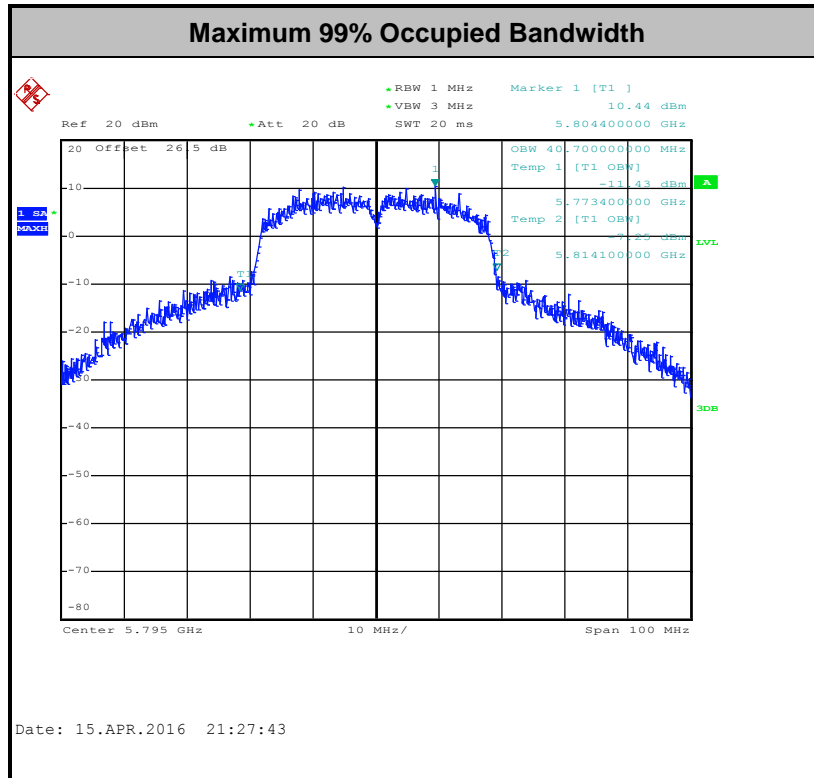

Note: The occupied channel bandwidth is maintained within the band of operation for all of the modulations.

3.2 Maximum Conducted Output Power Measurement

3.2.1 Limit of Maximum Conducted Output Power

For the band 5.725–5.85 GHz, the maximum conducted output power over the frequency band of operation shall not exceed 1 W.

If transmitting antennas of directional gain greater than 6 dBi are used, the peak output power shall be reduced by the amount in dB that the directional gain of the antenna exceeds 6 dBi.

3.2.2 Measuring Instruments

The measuring equipment is listed in the section 4 of this test report.

3.2.3 Test Procedures

The testing follows Method PM of FCC KDB 789033 D02 General UNII Test Procedures New Rules v01r02.

Method PM (Measurement using an RF average power meter):

1. Measurement is performed using a wideband RF power meter.
2. The EUT is configured to transmit continuously with a consistent duty cycle at its maximum power control level.
3. Measure the average power of the transmitter, and the average power is corrected with duty factor, $10 \log(1/x)$, where x is the duty cycle.

3.2.4 Test Setup

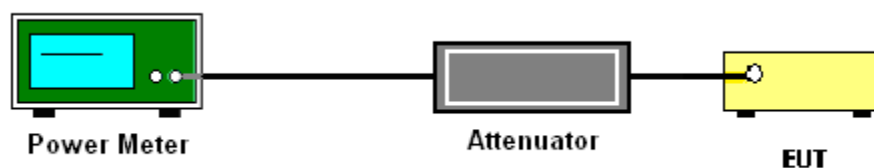

3.2.5 Test Result of Maximum Conducted Output Power

Please refer to Appendix A.



3.3 Power Spectral Density Measurement

3.3.1 Limit of Power Spectral Density

For the band 5.725–5.85 GHz, the maximum power spectral density shall not exceed 30 dBm in any 500-kHz band.

If transmitting antennas of directional gain greater than 6 dBi are used, the peak output power shall be reduced by the amount in dB that the directional gain of the antenna exceeds 6 dBi.

3.3.2 Measuring Instruments

The measuring equipment is listed in the section 4 of this test report.

3.3.3 Test Procedures

The testing follows FCC KDB 789033 D02 General UNII Test Procedures New Rules v01r02. Section F) Maximum power spectral density.

Method SA-2

(trace averaging across on and off times of the EUT transmissions, followed by duty cycle correction).

1. The testing follows Method SA-2 of FCC KDB 789033 D02 General UNII Test Procedures New Rules v01r02.
 - Measure the duty cycle.
 - Set span to encompass the entire emission bandwidth (EBW) of the signal.
 - Set RBW = 300 kHz.
 - Set VBW \geq 1 MHz.
 - Number of points in sweep \geq 2 Span / RBW.
 - Sweep time = auto.
 - Detector = RMS
 - Trace average at least 100 traces in power averaging mode.
 - Add $10 \log(500\text{kHz}/\text{RBW})$ to the test result.
 - Add $10 \log(1/x)$, where x is the duty cycle, to the measured power in order to compute the average power during the actual transmission times. For example, add $10 \log(1/0.25) = 6$ dB if the duty cycle is 25 percent.
2. The RF output of EUT was connected to the spectrum analyzer by a low loss cable.
3. Each plot has already offset with cable loss, and attenuator loss. Measure the PPSD and record it.

4. For MIMO mode, calculation method follows FCC KDB 662911 D01 Multiple Transmitter Output v02r01.

Method (a): Measure and sum the spectra across the outputs.

The total final Power Spectral Density is from a device with 2 transmitter outputs. The spectrum measurements of the individual outputs are all performed with the same span and number of points, the spectrum value in the first spectral bin of output 1 is summed with that in the first spectral bin of output 2 to obtain the value for the first frequency bin of the summed spectrum.

3.3.4 Test Setup

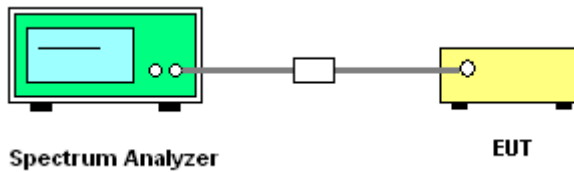

3.3.5 Test Result of Power Spectral Density

Please refer to Appendix A.

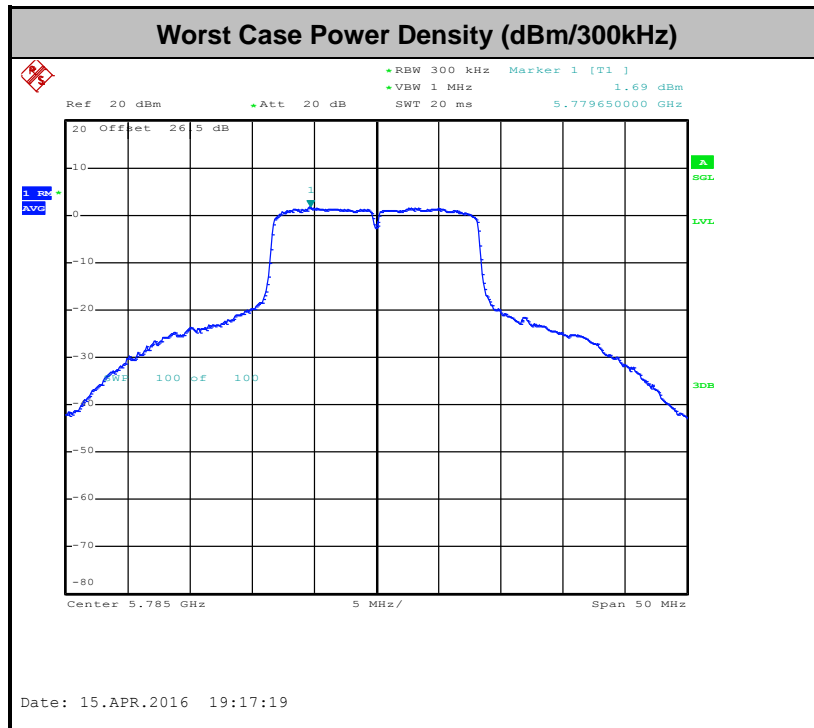



3.4 Unwanted Emissions Measurement

This section as specified in FCC Part 15.407(b) is to measure unwanted emissions through radiated measurement for band edge spurious emissions and out of band emissions measurement. The unwanted emissions shall comply with 15.407(b)(1) to (6), and restricted bands per FCC Part15.205.

3.4.1 Limit of Unwanted Emissions

- (1) For transmitters operating in the 5725-5850 MHz band: all emissions within the frequency range from the band edge to 10 MHz above or below the band edge shall not exceed an EIRP of -17 dBm/MHz (78.3dBµV/m); for frequencies 10 MHz or greater above or below the band edge, emissions shall not exceed an EIRP of -27 dBm/MHz (68.3dBµV/m).
- (2) Unwanted spurious emissions fallen in restricted bands per FCC Part15.205 shall comply with the general field strength limits set forth in § 15.209 as below table,

Frequency (MHz)	Field Strength (microvolts/meter)	Measurement Distance (meters)
0.009 – 0.490	2400/F(kHz)	300
0.490 – 1.705	24000/F(kHz)	30
1.705 – 30.0	30	30
30 – 88	100	3
88 – 216	150	3
216 - 960	200	3
Above 960	500	3

Note: The following formula is used to convert the EIRP to field strength.

$$E = \frac{1000000\sqrt{30P}}{3} \mu\text{V/m, where P is the eirp (Watts)}$$

EIRP (dBm)	Field Strength at 3m (dBµV/m)
-17	78.3
- 27	68.3

- (3) KDB 789033 D02 General UNII Test Procedures New Rules v01r02 G)2)c) As specified in 15.407(b), emissions above 1000 MHz that are outside of the restricted bands are subject to a peak emission limit of -27 dBm/MHz (or -17 dBm/MHz as specified in 15.407(b)(4)). However, an out-of-band emission that complies with both the average and peak limits of 15.209 is not required to satisfy the -27 dBm/MHz or -17 dBm/MHz peak emission limit.



3.4.2 Measuring Instruments

The measuring equipment is listed in the section 4 of this test report.

3.4.3 Test Procedures

1. The testing follows FCC KDB 789033 D02 General UNII Test Procedures New Rules v01r02. Section G) Unwanted emissions measurement.

(1) Procedure for Unwanted Emissions Measurements Below 1000MHz

- RBW = 120 kHz
- VBW = 300 kHz
- Detector = Peak
- Trace mode = max hold

(2) Procedure for Peak Unwanted Emissions Measurements Above 1000 MHz

- RBW = 1 MHz
- VBW ≥ 3 MHz
- Detector = Peak
- Sweep time = auto
- Trace mode = max hold

(3) Procedures for Average Unwanted Emissions Measurements Above 1000MHz

- RBW = 1 MHz
- VBW = 10 Hz, when duty cycle is no less than 98 percent.
- $VBW \geq 1/T$, when duty cycle is less than 98 percent where T is the minimum transmission duration over which the transmitter is on and is transmitting at its maximum power control level for the tested mode of operation.

Antenna	Band	Duty Cycle(%)	T(us)	1/T(kHz)	VBW Setting
1	802.11a	97.73	2064.00	0.48	1kHz
1	802.11n HT20	97.56	1920.00	0.52	1kHz
1	802.11n HT40	95.96	950.00	1.05	3kHz
1+2	802.11n HT20 for Ant1	98.36	-	-	1kHz
1+2	802.11n HT20 for Ant2	97.56	1920.00	0.52	1kHz
1+2	802.11n HT40 for Ant1	95.94	944.00	1.06	3kHz
1+2	802.11n HT40 for Ant2	95.96	950.00	1.05	3kHz

2. The EUT was placed on a turntable with 0.8 meter for frequency below 1GHz and 1.5 meter for frequency above 1GHz respectively above ground.
3. The EUT was set 3 meters from the interference receiving antenna which was mounted on the top of a variable height antenna tower.
4. The antenna is a broadband antenna and its height is adjusted between one meter and four

meters above ground to find the maximum value of the field strength for both horizontal polarization and vertical polarization of the antenna.

5. For each suspected emission, the EUT was arranged to its worst case and then adjust the antenna tower (from 1 m to 4 m) and turntable (from 0 degree to 360 degrees) to find the maximum reading.
6. For testing below 1GHz, if the emission level of the EUT in peak mode was 3 dB lower than the limit specified, then peak values of EUT will be reported, otherwise, the emissions will be repeated one by one using the CISPR quasi-peak method and reported.
7. For testing above 1GHz, the emission level of the EUT in peak mode was 20dB lower than average limit (that means the emission level in average mode also complies with the limit in average mode), then peak values of EUT will be reported, otherwise, the emissions will be measured in average mode again and reported.

3.4.4 Test Setup

For radiated emissions below 30MHz

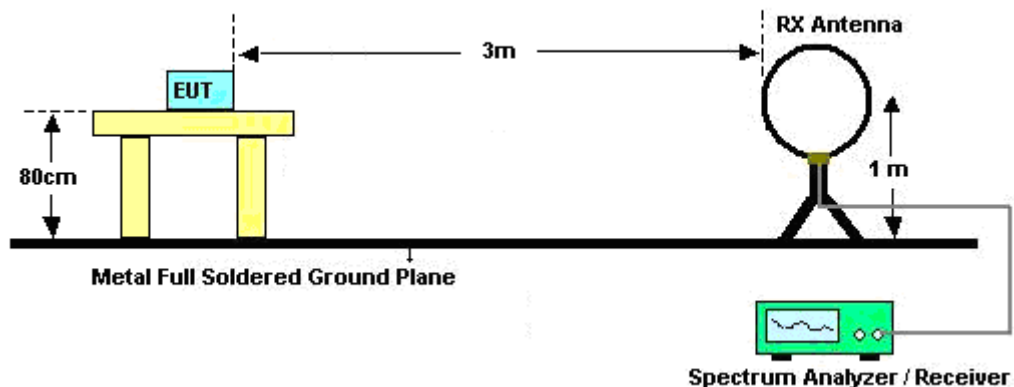

For radiated emissions from 30MHz to 1GHz

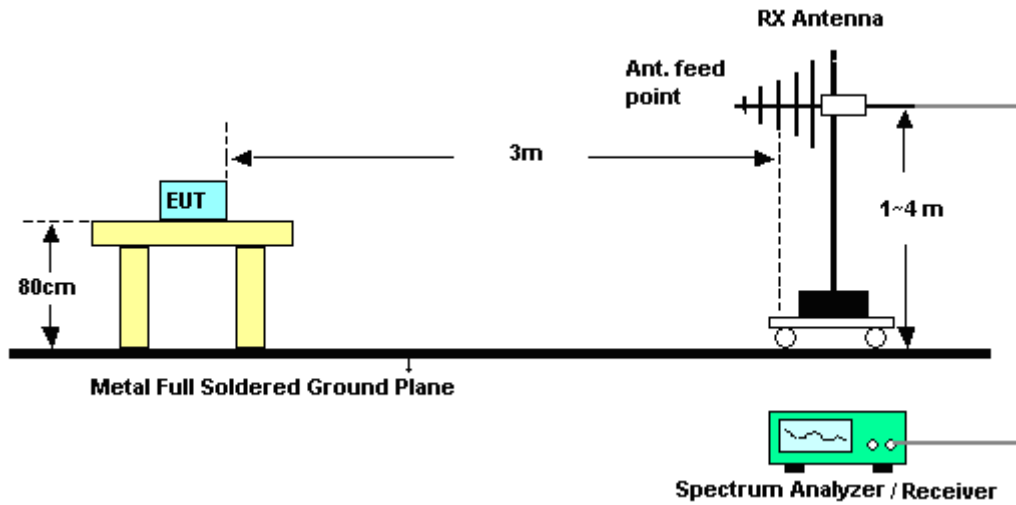

For radiated emissions above 1GHz

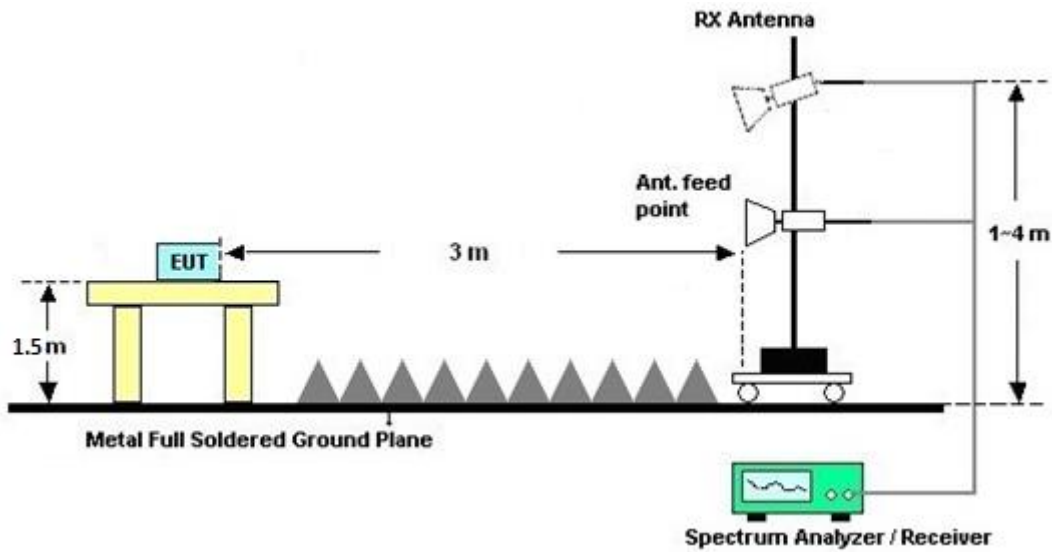

3.4.5 Test Results of Radiated Emissions (9 kHz ~ 30 MHz)

The low frequency, which started from 9 kHz to 30MHz, was pre-scanned and the result which was 20dB lower than the limit line per 15.31(o) was not reported.

3.4.6 Test Result of Radiated Band Edges

Please refer to Appendix B and Appendix C.



3.4.7 Duty Cycle

802.11a Ant. 1

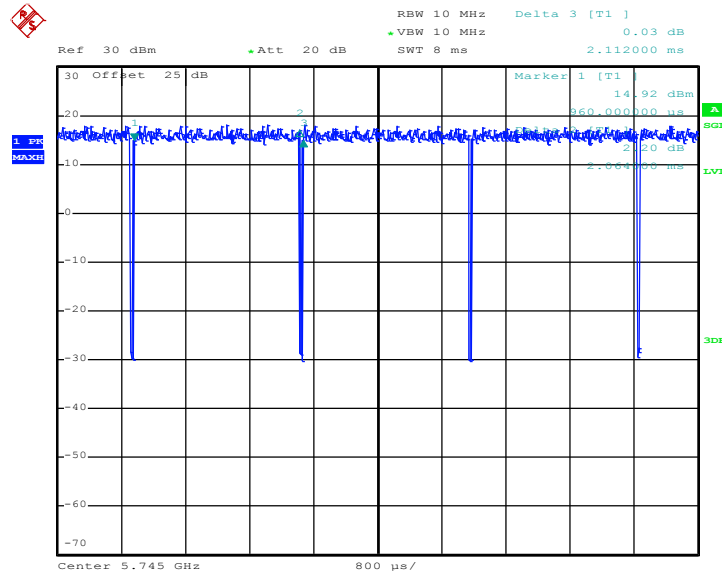

Date: 30.MAR.2016 22:05:00

802.11n HT20 SISO Ant. 1

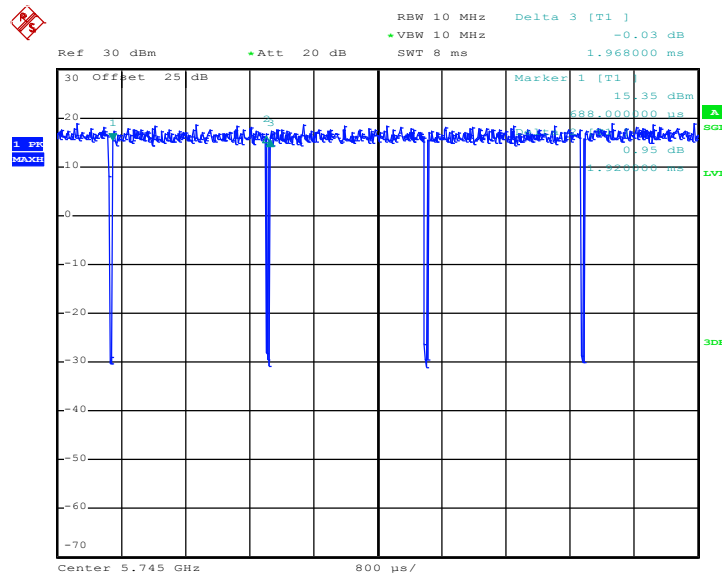

Date: 30.MAR.2016 22:12:28



802.11n HT20 MIMO Ant. 1+2(1)

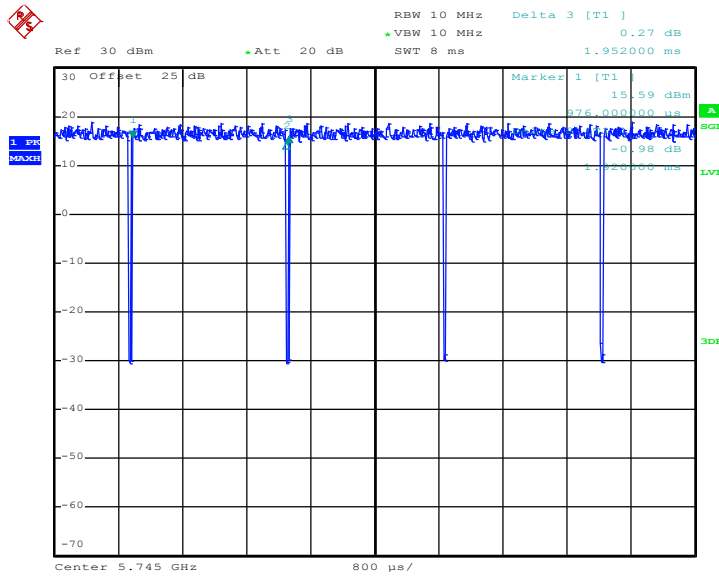

Date: 30.MAR.2016 22:15:42

802.11n HT20 MIMO Ant. 1+2(2)

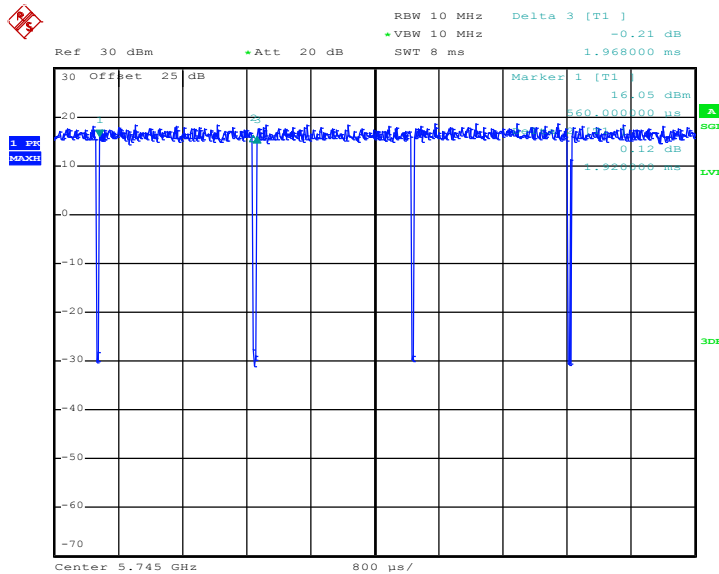

Date: 30.MAR.2016 22:16:59



802.11n HT40 SISO Ant. 1

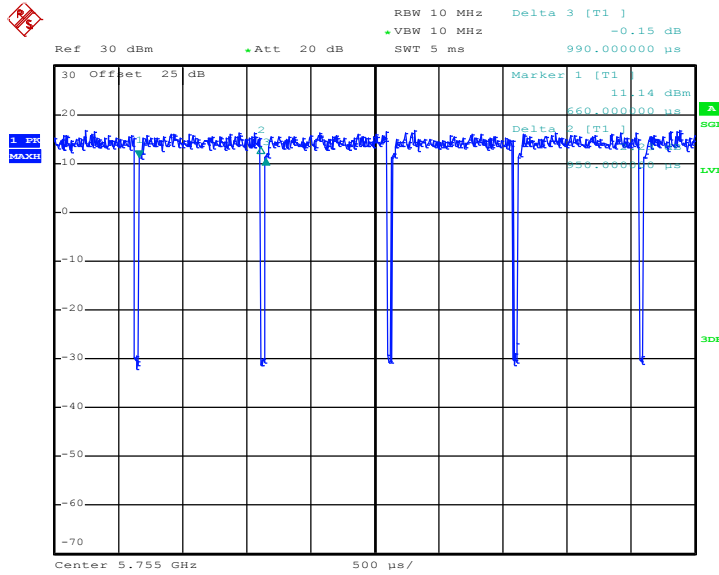

Date: 30.MAR.2016 22:31:10

802.11n HT40 MIMO Ant. 1+2(1)

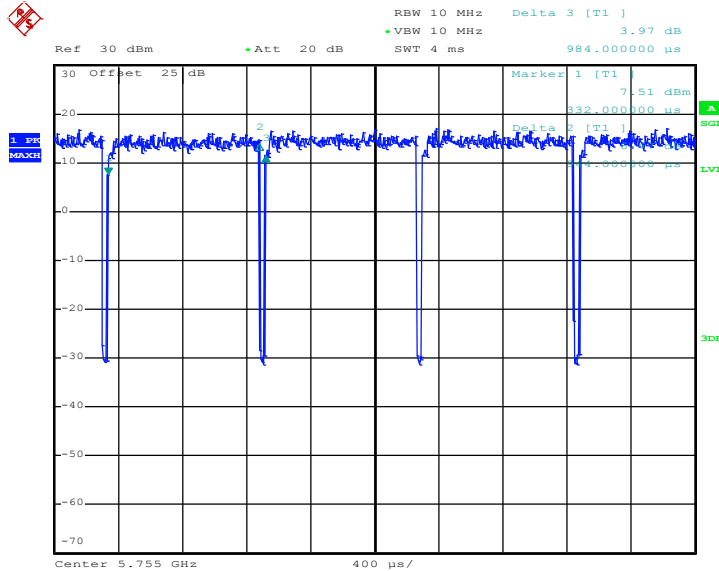

Date: 30.MAR.2016 22:36:03



802.11n HT40 MIMO Ant. 1+2(2)

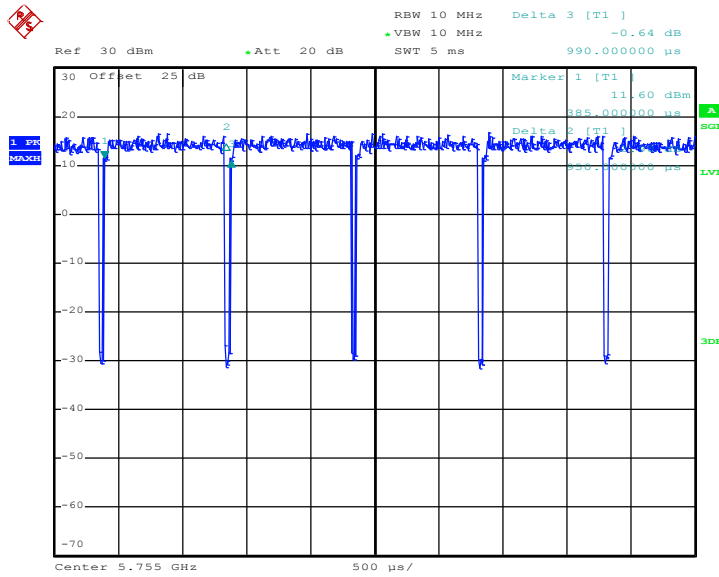

Date: 30.MAR.2016 22:39:09

3.4.8 Test Result of Unwanted Radiated Emission (30MHz ~ 10th Harmonic)

Please refer to Appendix B and Appendix C.



3.5 AC Conducted Emission Measurement

3.5.1 Limit of AC Conducted Emission

For equipment that is designed to be connected to the public utility (AC) power line, the radio frequency voltage that is conducted back onto the AC power line on any frequency or frequencies within the band 150 kHz to 30 MHz shall not exceed the limits in the following table.

Frequency of emission (MHz)	Conducted limit (dB μ V)	
	Quasi-peak	Average
0.15-0.5	66 to 56*	56 to 46*
0.5-5	56	46
5-30	60	50

*Decreases with the logarithm of the frequency.

3.5.2 Measuring Instruments

The measuring equipment is listed in the section 4 of this test report.

3.5.3 Test Procedures

1. The EUT was placed 0.4 meter from the conducting wall of the shielding room was kept at least 80 centimeters from any other grounded conducting surface.
2. Connect EUT to the power mains through a line impedance stabilization network (LISN).
3. All the support units are connecting to the other LISN.
4. The LISN provides 50 ohm coupling impedance for the measuring instrument.
5. The FCC states that a 50 ohm, 50 microhenry LISN should be used.
6. Both sides of AC line were checked for maximum conducted interference.
7. The frequency range from 150 kHz to 30 MHz was searched.
8. Set the test-receiver system to Peak Detect Function and specified bandwidth with Maximum Hold Mode.

3.5.4 Test Setup

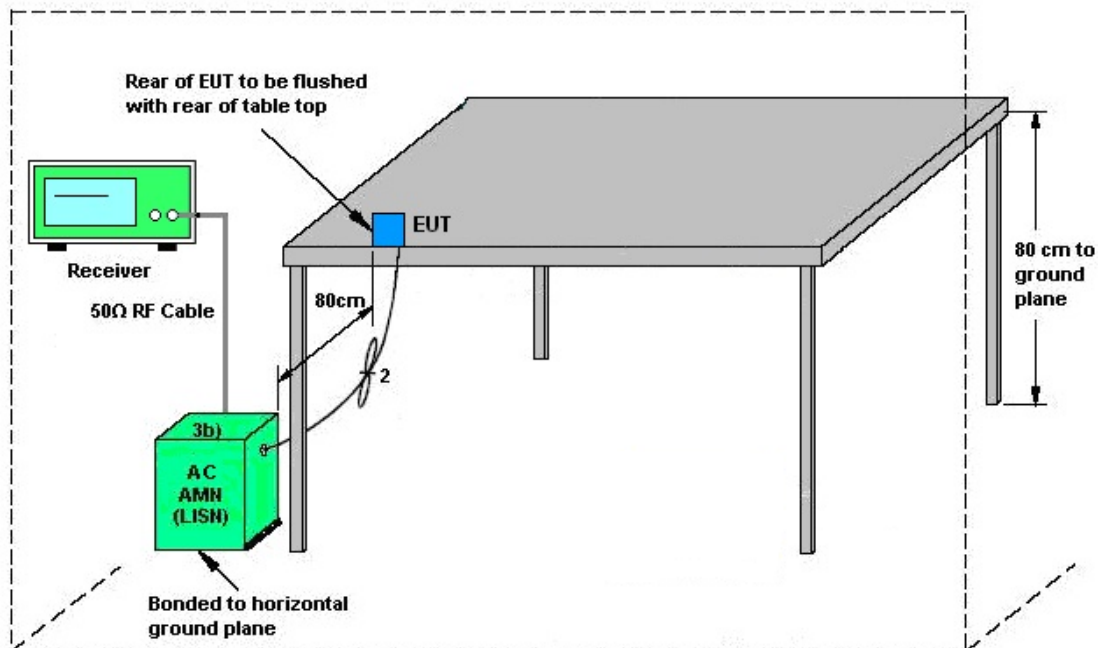

AMN = Artificial mains network (LISN)
AE = Associated equipment
EUT = Equipment under test
ISN = Impedance stabilization network



3.5.5 Test Result of AC Conducted Emission

Test Mode :	Mode 1	Temperature :	22~23°C
Test Engineer :	Derreck Chen	Relative Humidity :	51~52%
Test Voltage :	120Vac / 60Hz	Phase :	Line
Function Type :	WLAN (5G) Link + Adapter + MP3		

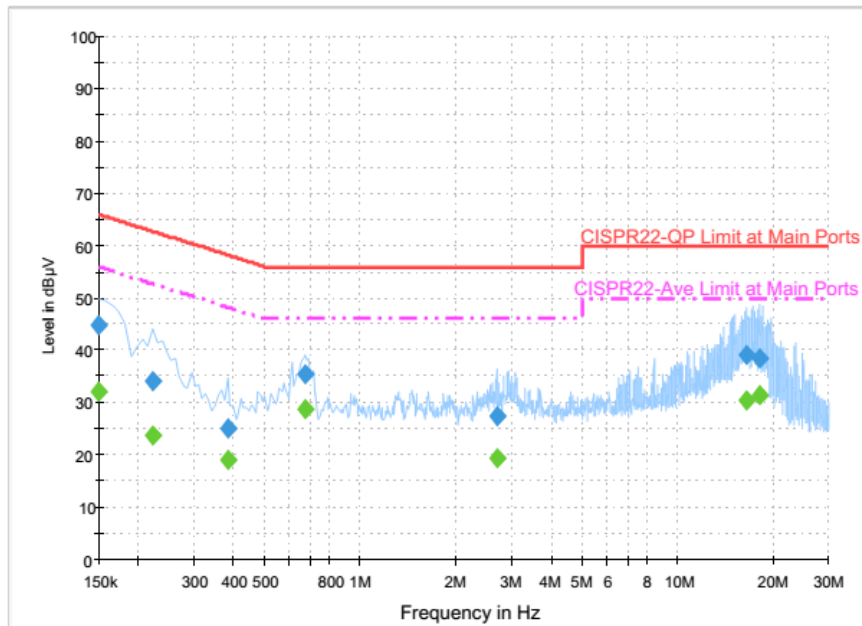

Final Result : QuasiPeak

Frequency (MHz)	QuasiPeak (dBµV)	Filter	Line	Corr. (dB)	Margin (dB)	Limit (dBµV)
0.150000	44.8	Off	L1	19.6	21.2	66.0
0.222000	34.0	Off	L1	19.6	28.7	62.7
0.382000	25.0	Off	L1	19.6	33.2	58.2
0.670000	35.4	Off	L1	19.6	20.6	56.0
2.694000	27.5	Off	L1	19.6	28.5	56.0
16.622000	39.1	Off	L1	19.8	20.9	60.0
18.230000	38.4	Off	L1	19.8	21.6	60.0

Final Result : Average

Frequency (MHz)	Average (dBµV)	Filter	Line	Corr. (dB)	Margin (dB)	Limit (dBµV)
0.150000	32.0	Off	L1	19.6	24.0	56.0
0.222000	23.9	Off	L1	19.6	28.8	52.7
0.382000	19.0	Off	L1	19.6	29.2	48.2
0.670000	28.6	Off	L1	19.6	17.4	46.0
2.694000	19.4	Off	L1	19.6	26.6	46.0
16.622000	30.3	Off	L1	19.8	19.7	50.0
18.230000	31.6	Off	L1	19.8	18.4	50.0



Test Mode :	Mode 1	Temperature :	22~23°C
Test Engineer :	Derreck Chen	Relative Humidity :	51~52%
Test Voltage :	120Vac / 60Hz	Phase :	Neutral
Function Type :	WLAN (5G) Link + Adapter + MP3		

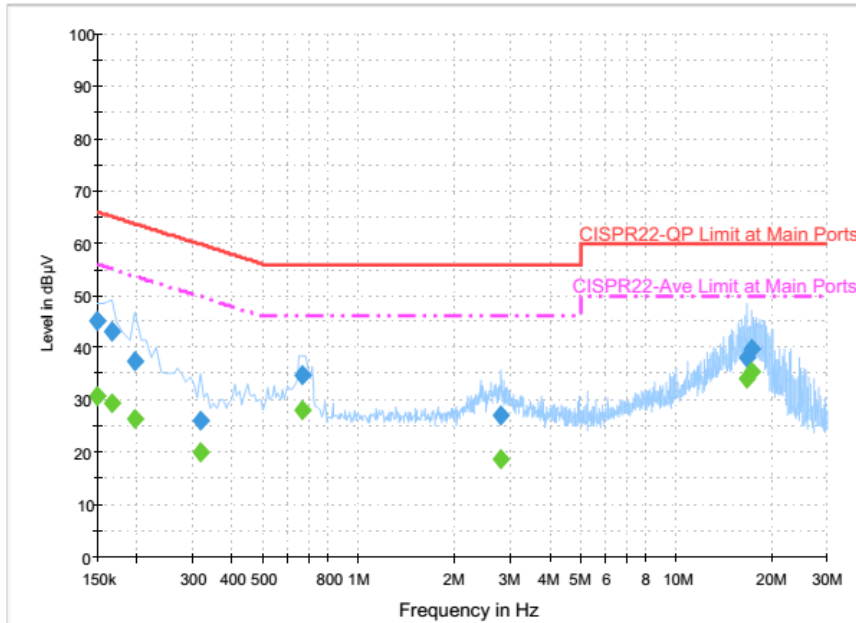

Final Result : QuasiPeak

Frequency (MHz)	QuasiPeak (dBµV)	Filter	Line	Corr. (dB)	Margin (dB)	Limit (dBµV)
0.150000	45.1	Off	N	19.6	20.9	66.0
0.166000	43.0	Off	N	19.6	22.2	65.2
0.198000	37.4	Off	N	19.6	26.3	63.7
0.318000	26.2	Off	N	19.6	33.6	59.8
0.662000	34.9	Off	N	19.6	21.1	56.0
2.822000	27.1	Off	N	19.6	28.9	56.0
16.774000	38.2	Off	N	19.9	21.8	60.0
17.310000	39.9	Off	N	19.9	20.1	60.0

Final Result : Average

Frequency (MHz)	Average (dBµV)	Filter	Line	Corr. (dB)	Margin (dB)	Limit (dBµV)
0.150000	30.8	Off	N	19.6	25.2	56.0
0.166000	29.5	Off	N	19.6	25.7	55.2
0.198000	26.4	Off	N	19.6	27.3	53.7
0.318000	20.0	Off	N	19.6	29.8	49.8
0.662000	28.1	Off	N	19.6	17.9	46.0
2.822000	18.9	Off	N	19.6	27.1	46.0
16.774000	34.1	Off	N	19.9	15.9	50.0
17.310000	35.3	Off	N	19.9	14.7	50.0

3.6 Frequency Stability Measurement

3.6.1 Limit of Frequency Stability

Manufacturers of U-NII devices are responsible for ensuring frequency stability such that an emission is maintained within the band of operation under all conditions of normal operation as specified in the user's manual.

3.6.2 Measuring Instruments

The measuring equipment is listed in the section 4 of this test report.

3.6.3 Test Procedures

1. To ensure emission at the band edge is maintained within the authorized band, those values shall be measured by radiation emissions at upper and lower frequency points, and finally compensated by frequency deviation as procedures below.
2. The EUT was operated at the maximum output power, and connected to the spectrum analyzer, which is set to maximum hold function and peak detector. The peak value of the power envelope was measured and noted. The upper and lower frequency points were respectively measured relatively 10dB lower than the measured peak value.
3. The frequency deviation was calculated by adding the upper frequency point and the lower frequency point divided by two. Those detailed values of frequency deviation are provided in table below.

3.6.4 Test Setup

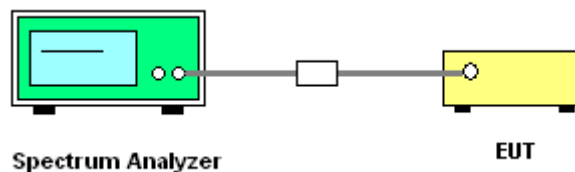

3.6.5 Test Result of Frequency Stability

Please refer to Appendix A.



3.7 Automatically Discontinue Transmission

3.7.1 Limit of Automatically Discontinue Transmission

The device shall automatically discontinue transmission in case of either absence of information to transmit or operational failure. These provisions are not intended to preclude the transmission of control or signaling information or the use of repetitive codes used by certain digital technologies to complete frame or burst intervals. Applicants shall include in their application for equipment authorization to describe how this requirement is met.

3.7.2 Measuring Instruments

The measuring equipment is listed in the section 4 of this test report.

3.7.3 Test Result of Automatically Discontinue Transmission

EUT is verified this characteristic during the function check of normal sample associated with an access point:

- A. Information start: make EUT supply information to the access point.
- B. Information stop: stop supplying information to the access point.

While the EUT is not transmitting any information, the EUT can automatically discontinue transmission and become standby mode for power saving.

- C. Information start: make EUT supply information to the access point again.

The EUT can detect the controlling signal of ACK message transmitting from remote device and verify whether it shall resend or discontinue transmission.

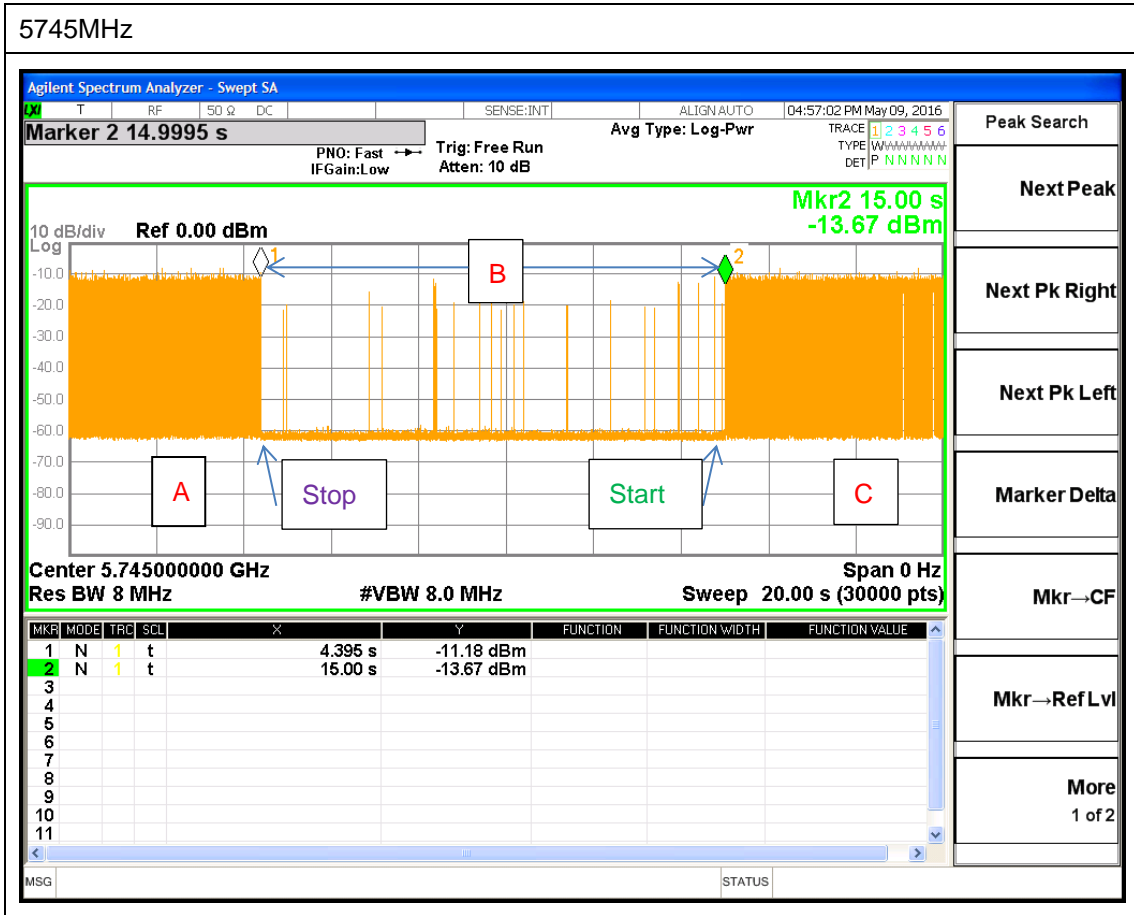

Note: The control / signalling information during the period B is precluded.



3.8 Antenna Requirements

3.8.1 Standard Applicable

According to FCC 47 CFR Section 15.407(a)(1)(2) ,if transmitting antenna directional gain is greater than 6 dBi, both the peak transmit power and the peak power spectral density shall be reduced by the amount in dB that the directional gain of the antenna exceeds 6 dBi.

3.8.2 Antenna Anti-Replacement Construction

An embedded-in antenna design is used.

3.8.3 Antenna Gain

FCC KDB 662911 D01 Multiple Transmitter Output v02r01

For CDD transmissions, directional gain is calculated as

Directional gain = $G_{ANT} + \text{Array Gain}$, where Array Gain is as follows.

For power spectral density (PSD) measurements on all devices,

Array Gain = $10 \log(N_{ANT}/N_{SS}=1)$ dB.

For power measurements on IEEE 802.11 devices,

Array Gain = 0 dB (i.e., no array gain) for $N_{ANT} \leq 4$.

The EUT supports CDD mode.

The power and PSD limit should be modified if the directional gain of EUT is over 6 dBi,

The directional gain “DG” is calculated as following table.

			DG	DG	Power	PSD
			for	for	Limit	Limit
	Ant 1	Ant 2	Power	PSD	Reduction	Reduction
	(dBi)	(dBi)	(dBi)	(dBi)	(dB)	(dB)
Band IV	5.74	4.30	5.74	8.06	0.00	2.06

Power limit reduction = Composite gain – 6dBi, (min = 0)

PSD limit reduction = Composite gain + PSD Array gain – 6dBi, (min = 0)



4 List of Measuring Equipment

Instrument	Manufacturer	Model No.	Serial No.	Characteristics	Calibration Date	Test Date	Due Date	Remark
AC Power Source	AC POWER	AFC-500W	F104070011	50Hz~60Hz	Dec. 02, 2015	Mar. 30, 2016 ~ Apr. 15, 2016	Dec. 01, 2016	Conducted (TH05-HY)
Power Meter	Anritsu	ML2495A	1132003	300MHz~40GHz	Aug. 12, 2015	Mar. 30, 2016 ~ Apr. 15, 2016	Aug. 11, 2016	Conducted (TH05-HY)
Power Sensor	Anritsu	MA2411B	1126017	300MHz~40GHz	Aug. 12, 2015	Mar. 30, 2016 ~ Apr. 15, 2016	Aug. 11, 2016	Conducted (TH05-HY)
Spectrum Analyzer	Rohde & Schwarz	FSP40	100057	9kHz-40GHz	Nov. 23, 2015	Mar. 30, 2016 ~ Apr. 15, 2016	Nov. 22, 2016	Conducted (TH05-HY)
Temperature Chamber	ESPEC	SU-241	92003713	-30°C ~95°C	Jun. 15, 2015	Mar. 30, 2016 ~ Apr. 15, 2016	Jun. 14, 2016	Conducted (TH05-HY)
AC Power Source	ChainTek	APC-1000W	N/A	N/A	N/A	Mar. 29, 2016	N/A	Conduction (CO05-HY)
EMI Test Receiver	Rohde & Schwarz	ESCI 7	100724	9kHz~7GHz	Aug. 26, 2015	Mar. 29, 2016	Aug. 25, 2016	Conduction (CO05-HY)
LISN	Rohde & Schwarz	ENV216	100080	9kHz~30MHz	Dec. 02, 2015	Mar. 29, 2016	Dec. 01, 2016	Conduction (CO05-HY)
LF Cable	HUBER + SUHNER	RG-214/U	LF01	N/A	Jan. 06, 2016	Mar. 29, 2016	Jan. 05, 2017	Conduction (CO05-HY)
Pulse Limiter	Rohde & Schwarz	ESH3-Z2	100851	N/A	Jan. 08, 2016	Mar. 29, 2016	Jan. 07, 2017	Conduction (CO05-HY)
Loop Antenna	Rohde & Schwarz	HFH2-Z2	100315	9 kHz~30 MHz	Sep. 02, 2015	Apr. 08, 2016 ~ Apr. 12, 2016	Sep. 01, 2016	Radiation (03CH10-HY)
Loop Cable	Rohde & Schwarz	N/A	N/A	9KHz~30MHz	Dec. 03, 2015	Apr. 08, 2016 ~ Apr. 12, 2016	Dec. 02, 2016	Radiation (03CH10-HY)
Amplifier	SONOMA	310N	187311	9kHz~1GHz	Nov. 16, 2015	Apr. 08, 2016 ~ Apr. 12, 2016	Nov. 15, 2016	Radiation (03CH10-HY)
Bilog Antenna	TESEQ	CBL 6111D	35413	30MHz~1GHz	Jan. 13, 2016	Apr. 08, 2016 ~ Apr. 12, 2016	Jan. 12, 2017	Radiation (03CH10-HY)
Horn Antenna	SCHWARZBECK	BBHA 9120 D	9120D-1325	1GHz ~ 18GHz	Sep. 30, 2015	Apr. 08, 2016 ~ Apr. 12, 2016	Sep. 29, 2016	Radiation (03CH10-HY)
Preamplifier	Keysight	83017A	MY53270078	1GHz~26.5GHz	Nov. 13, 2015	Apr. 08, 2016 ~ Apr. 12, 2016	Nov. 12, 2016	Radiation (03CH10-HY)
Preamplifier	MITEQ	AMF-7D-0010 1800-30-10P	1902246	1GHz~18GHz	Nov. 16, 2015	Apr. 08, 2016 ~ Apr. 12, 2016	Nov. 15, 2016	Radiation (03CH10-HY)
Spectrum Analyzer	Keysight	N9010A	MY54200485	10Hz ~ 44GHz	Oct. 15, 2015	Apr. 08, 2016 ~ Apr. 12, 2016	Oct. 14, 2016	Radiation (03CH10-HY)
Antenna Mast	EMEC	AM-BS-4500-B	N/A	1~4m	N/A	Apr. 08, 2016 ~ Apr. 12, 2016	N/A	Radiation (03CH10-HY)
Turn Table	EMEC	TT 2200	N/A	0~360 Degree	N/A	Apr. 08, 2016 ~ Apr. 12, 2016	N/A	Radiation (03CH10-HY)
SHF-EHF Horn Antenna	SCHWARZBECK	BBHA 9170	BBHA9170584	18GHz- 40GHz	Nov. 02, 2015	Apr. 08, 2016 ~ Apr. 12, 2016	Nov. 01, 2016	Radiation (03CH10-HY)
EMI Test Receiver	Agilent	N9038A(MXE)	MY53290053	20Hz to 26.5GHz	Jan. 20, 2016	Apr. 08, 2016 ~ Apr. 12, 2016	Jan. 19, 2017	Radiation (03CH10-HY)
Preamplifier	MITEQ	JS44-1800400 0-33-8P	1840917	18GHz ~ 40GHz	Jun. 02, 2015	Apr. 08, 2016 ~ Apr. 12, 2016	Jun. 01, 2016	Radiation (03CH10-HY)



5 Uncertainty of Evaluation

Uncertainty of Conducted Emission Measurement (150kHz ~ 30MHz)

Measuring Uncertainty for a Level of Confidence of 95% ($U = 2Uc(y)$)	2.26
---	------

Uncertainty of Radiated Emission Measurement (30 MHz ~ 1000 MHz)

Measuring Uncertainty for a Level of Confidence of 95% ($U = 2Uc(y)$)	5.5
---	-----



Appendix A. Conducted Test Results

Test Engineer:	Derek Hsu	Temperature:	21~25	°C
Test Date:	2016/03/30~2016/04/15	Relative Humidity:	51~54	%

TEST RESULTS DATA
6dB and 26dB EBW and 99% OBW

Band IV													
Mod.	Data Rate	NTX	CH.	Freq. (MHz)	99% Bandwidth (MHz)		26dB Bandwidth (MHz)		6 dB Bandwidth (MHz)		6 dB Bandwidth Min. Limit (MHz)		Pass/Fail
					Ant 1	Ant 2	Ant 1	Ant 2	Ant 1	Ant 2	Ant 1	Ant 2	
11a	6Mbps	1	149	5745	17.35		25.05		15.52		0.5	0.5	Pass
11a	6Mbps	1	157	5785	18.20		37.35		15.54		0.5	0.5	Pass
11a	6Mbps	1	165	5825	17.95		37.20		15.52		0.5	0.5	Pass
HT20	MCS0	1	149	5745	18.40		27.05		16.56		0.5	0.5	Pass
HT20	MCS0	1	157	5785	18.85		35.50		16.80		0.5	0.5	Pass
HT20	MCS0	1	165	5825	18.85		38.50		16.52		0.5	0.5	Pass
HT40	MCS0	1	151	5755	36.00		43.68		33.76		0.5	0.5	Pass
HT40	MCS0	1	159	5795	36.30		56.07		32.56		0.5	0.5	Pass
HT20	MCS0	2	149	5745	18.40	18.40	30.30	29.60	16.80	16.52	0.5		Pass
HT20	MCS0	2	157	5785	22.45	24.20	45.35	46.70	16.54	15.94	0.5		Pass
HT20	MCS0	2	165	5825	23.30	21.40	44.90	44.65	16.52	15.34	0.5		Pass
HT40	MCS0	2	151	5755	36.00	36.00	45.18	43.68	32.56	32.56	0.5		Pass
HT40	MCS0	2	159	5795	38.80	40.70	74.97	74.46	32.56	32.48	0.5		Pass

TEST RESULTS DATA
Average Power Table

Band IV														
Mod.	Data Rate	NTX	CH.	Freq. (MHz)	Duty Factor (dB)		Average Conducted Power (dBm)			FCC Conducted Power Limit (dBm)		DG (dBi)		Pass/Fail
					Ant 1	Ant 2	Ant 1	Ant 2	SUM	Ant 1	Ant 2	Ant 1	Ant 2	
11a	6Mbps	1	149	5745	0.10		15.63			30.00	30.00	5.74	4.30	Pass
11a	6Mbps	1	157	5785	0.10		17.92			30.00	30.00	5.74	4.30	Pass
11a	6Mbps	1	165	5825	0.10		17.95			30.00	30.00	5.74	4.30	Pass
HT20	MCS0	1	149	5745	0.11		15.73			30.00	30.00	5.74	4.30	Pass
HT20	MCS0	1	157	5785	0.11		17.63			30.00	30.00	5.74	4.30	Pass
HT20	MCS0	1	165	5825	0.11		17.74			30.00	30.00	5.74	4.30	Pass
HT40	MCS0	1	151	5755	0.18		13.60			30.00	30.00	5.74	4.30	Pass
HT40	MCS0	1	159	5795	0.18		17.55			30.00	30.00	5.74	4.30	Pass
HT20	MCS0	2	149	5745	0.07	0.11	16.15	13.64	18.08	30.00		5.74		Pass
HT20	MCS0	2	157	5785	0.07	0.11	18.73	16.31	20.70	30.00		5.74		Pass
HT20	MCS0	2	165	5825	0.07	0.11	18.21	15.82	20.19	30.00		5.74		Pass
HT40	MCS0	2	151	5755	0.18	0.18	13.47	11.18	15.48	30.00		5.74		Pass
HT40	MCS0	2	159	5795	0.18	0.18	18.44	16.45	20.57	30.00		5.74		Pass

TEST RESULTS DATA
Power Spectral Density

Band IV																
Mod.	Data Rate	NTX	CH.	Freq. (MHz)	Duty Factor (dB)		10log (500kHz /RBW) Factor (dB)		Average Power Density (dBm/500kHz)			Average PSD Limit (dBm/500kHz)		DG (dBi)		Pass /Fail
					Ant 1	Ant 2	Ant 1	Ant 2	Ant 1	Ant 2	SUM	Ant 1	Ant 2	Ant 1	Ant 2	
11a	6Mbps	1	149	5745	0.10		2.22	2.22	1.47			30.00	30.00	5.74	4.30	Pass
11a	6Mbps	1	157	5785	0.10		2.22	2.22	4.01			30.00	30.00	5.74	4.30	Pass
11a	6Mbps	1	165	5825	0.10		2.22	2.22	3.56			30.00	30.00	5.74	4.30	Pass
HT20	MCS0	1	149	5745	0.11		2.22	2.22	1.37			30.00	30.00	5.74	4.30	Pass
HT20	MCS0	1	157	5785	0.11		2.22	2.22	2.82			30.00	30.00	5.74	4.30	Pass
HT20	MCS0	1	165	5825	0.11		2.22	2.22	3.27			30.00	30.00	5.74	4.30	Pass
HT40	MCS0	1	151	5755	0.18		2.22	2.22	-3.33			30.00	30.00	5.74	4.30	Pass
HT40	MCS0	1	159	5795	0.18		2.22	2.22	0.69			30.00	30.00	5.74	4.30	Pass
HT20	MCS0	2	149	5745	0.07	0.11	2.22				4.42	27.94		8.06		Pass
HT20	MCS0	2	157	5785	0.07	0.11	2.22				6.88	27.94		8.06		Pass
HT20	MCS0	2	165	5825	0.07	0.11	2.22				6.30	27.94		8.06		Pass
HT40	MCS0	2	151	5755	0.18	0.18	2.22				-0.17	27.94		8.06		Pass
HT40	MCS0	2	159	5795	0.18	0.18	2.22				4.40	27.94		8.06		Pass

TEST RESULTS DATA
Frequency Stability

Band IV										
Mod.	Data Rate	NTX	CH.	Freq. (MHz)	Center Frequency (MHz)	Frequency Deviation (MHz)	Frequency Stability (ppm)	Temperature (°C)	Voltage (V)	Note
11a	6Mbps	1	149	5745	5744.950	-0.050	-8.70	20	102	
11a	6Mbps	1	149	5745	5744.950	-0.050	-8.70	20	138	
11a	6Mbps	1	149	5745	5745.000	0.000	0.00	20	120	
11a	6Mbps	1	149	5745	5745.000	0.000	0.00	0	120	
11a	6Mbps	1	149	5745	5744.950	-0.050	-8.70	35	120	



Appendix B. Radiated Spurious Emission

Test Engineer :	Stan Hsieh, Nick Yu, and Tsung Lee	Temperature :	22~25°C
		Relative Humidity :	45~48%

Band 4 - 5725~5850MHz
WIFI 802.11a (Band Edge @ 3m)

WIFI Ant. 1	Note	Frequency (MHz)	Level (dBμV/m)	Over Limit (dB)	Limit Line (dBμV/m)	Read Level (dBμV)	Antenna Factor (dB/m)	Cable Loss (dB)	Preamp Factor (dB)	Ant Pos (cm)	Table Pos (deg)	Peak Avg. (P/A)	Pol. (H/V)	
802.11a CH 149 5745MHz		5714.6	54.49	-19.51	74	46.33	32.52	8.3	32.66	147	49	P	H	
		5724.68	76.42	-1.88	78.3	68.22	32.53	8.33	32.66	147	49	P	H	
		5714.68	44.6	-9.4	54	36.44	32.52	8.3	32.66	147	49	A	H	
	*	5747	111.27	-	-	103.07	32.54	8.33	32.67	147	49	P	H	
	*	5747	104.03	-	-	95.83	32.54	8.33	32.67	147	49	A	H	
														H
														H
														H
			5713.56	50.63	-23.37	74	42.47	32.52	8.3	32.66	100	56	P	V
			5724.76	70.92	-7.38	78.3	62.72	32.53	8.33	32.66	100	56	P	V
			5715	41.17	-12.83	54	33.01	32.52	8.3	32.66	100	56	A	V
	*		5743	105.91	-	-	97.71	32.54	8.33	32.67	100	56	P	V
	*		5743	99.13	-	-	90.93	32.54	8.33	32.67	100	56	A	V
														V
														V
													V	



WIFI Ant. 1	Note	Frequency (MHz)	Level (dBµV/m)	Over Limit (dB)	Limit Line (dBµV/m)	Read Level (dBµV)	Antenna Factor (dB/m)	Cable Loss (dB)	Preamp Factor (dB)	Ant Pos (cm)	Table Pos (deg)	Peak Avg. (P/A)	Pol. (H/V)
802.11a CH 157 5785MHz		5703.8	48.58	-25.42	74	40.41	32.52	8.3	32.65	128	50	P	H
		5721.96	48.88	-29.42	78.3	40.68	32.53	8.33	32.66	128	50	P	H
		5701.08	40.26	-13.74	54	32.09	32.52	8.3	32.65	128	50	A	H
	*	5787	112.48	-	-	104.23	32.58	8.35	32.68	128	50	P	H
	*	5787	105.24	-	-	96.99	32.58	8.35	32.68	128	50	A	H
		5858.08	47.62	-30.68	78.3	39.28	32.62	8.43	32.71	128	50	P	H
		5888.8	47.34	-26.66	74	38.95	32.64	8.47	32.72	128	50	P	H
		5883.76	39.62	-14.38	54	31.24	32.63	8.47	32.72	128	50	A	H
		5700.6	48.92	-25.08	74	40.75	32.52	8.3	32.65	103	53	P	V
		5725	47.94	-30.36	78.3	39.74	32.53	8.33	32.66	103	53	P	V
		5703.88	39.41	-14.59	54	31.24	32.52	8.3	32.65	103	53	A	V
	*	5783	108	-	-	99.76	32.57	8.35	32.68	103	53	P	V
	*	5783	100.87	-	-	92.63	32.57	8.35	32.68	103	53	A	V
		5859.92	47.33	-30.97	78.3	38.99	32.62	8.43	32.71	103	53	P	V
		5874.48	48.01	-25.99	74	39.66	32.63	8.43	32.71	103	53	P	V
		5884.08	39.28	-14.72	54	30.9	32.63	8.47	32.72	103	53	A	V



WIFI Ant. 1	Note	Frequency (MHz)	Level (dBμV/m)	Over Limit (dB)	Limit Line (dBμV/m)	Read Level (dBμV)	Antenna Factor (dB/m)	Cable Loss (dB)	Preamp Factor (dB)	Ant Pos (cm)	Table Pos (deg)	Peak Avg. (P/A)	Pol. (H/V)	
802.11a CH 165 5825MHz	*	5827	111.12	-	-	102.82	32.6	8.39	32.69	115	55	P	H	
	*	5827	104.85	-	-	96.55	32.6	8.39	32.69	115	55	A	H	
		5851.6	67.63	-10.67	78.3	59.29	32.61	8.43	32.7	115	55	P	H	
		5860.16	52.69	-21.31	74	44.35	32.62	8.43	32.71	115	55	P	H	
		5860	45.97	-8.03	54	37.63	32.62	8.43	32.71	115	55	A	H	
														H
														H
														H
	*	5824	106.46	-	-	98.16	32.6	8.39	32.69	102	54	P	V	
	*	5824	100.05	-	-	91.75	32.6	8.39	32.69	102	54	A	V	
		5850.96	61.77	-16.53	78.3	53.43	32.61	8.43	32.7	102	54	P	V	
		5860.08	49.54	-24.46	74	41.2	32.62	8.43	32.71	102	54	P	V	
		5860.08	41.77	-12.23	54	33.43	32.62	8.43	32.71	102	54	A	V	
														V
														V
														V
													V	
Remark	1. No other spurious found. 2. All results are PASS against Peak and Average limit line.													



Band 4 5725~5850MHz

WIFI 802.11a (Harmonic @ 3m)

WIFI Ant. 1	Note	Frequency (MHz)	Level (dBμV/m)	Over Limit (dB)	Limit Line (dBμV/m)	Read Level (dBμV)	Antenna Factor (dB/m)	Cable Loss (dB)	Preamp Factor (dB)	Ant Pos (cm)	Table Pos (deg)	Peak Avg. (P/A)	Pol. (H/V)
802.11a CH 149 5745MHz		11490	46.47	-27.53	74	56.68	40.01	12.58	62.8	100	0	P	H
		17232	46.6	-27.4	74	50.08	41.05	15.61	60.14	100	0	P	H
													H
													H
		11490	44.96	-29.04	74	55.17	40.01	12.58	62.8	100	0	P	V
		17232	46.11	-27.89	74	49.59	41.05	15.61	60.14	100	0	P	V
													V
													V
802.11a CH 157 5785MHz		11570	45.79	-28.21	74	55.99	39.88	12.66	62.74	100	0	P	H
		17352	53.75	-20.25	74	56.83	41.38	15.75	60.21	113	272	P	H
		17352	47.71	-6.29	54	50.79	41.38	15.75	60.21	113	272	A	H
													H
		11570	44.59	-29.41	74	54.79	39.88	12.66	62.74	100	0	P	V
		17352	52.4	-21.6	74	55.48	41.38	15.75	60.21	255	100	P	V
		17352	42.18	-11.82	54	45.26	41.38	15.75	60.21	255	100	A	V
													V
802.11a CH 165 5825MHz		11650	45.74	-28.26	74	55.95	39.75	12.73	62.69	100	0	P	H
		17472	53.01	-20.99	74	55.7	41.71	15.88	60.28	110	274	P	H
		17472	48.31	-5.69	54	51	41.71	15.88	60.28	110	274	A	H
													H
		11650	44.32	-29.68	74	54.53	39.75	12.73	62.69	100	0	P	V
		17472	51.85	-22.15	74	54.54	41.71	15.88	60.28	258	101	P	V
		17472	41.65	-12.35	54	44.34	41.71	15.88	60.28	258	101	A	V
													V
Remark	1. No other spurious found. 2. All results are PASS against Peak and Average limit line.												



Band 4 5725~5850MHz

WIFI 802.11n HT20 (Band Edge @ 3m)

WIFI Ant. 1	Note	Frequency (MHz)	Level (dBμV/m)	Over Limit (dB)	Limit Line (dBμV/m)	Read Level (dBμV)	Antenna Factor (dB/m)	Cable Loss (dB)	Preamp Factor (dB)	Ant Pos (cm)	Table Pos (deg)	Peak Avg. (P/A)	Pol. (H/V)	
802.11n HT20 CH 149 5745MHz		5714.92	53.36	-20.64	74	45.2	32.52	8.3	32.66	137	52	P	H	
		5724.68	76.74	-1.56	78.3	68.54	32.53	8.33	32.66	137	52	P	H	
		5714.76	43.82	-10.18	54	35.66	32.52	8.3	32.66	137	52	A	H	
	*	5746	109.98	-	-	101.78	32.54	8.33	32.67	137	52	P	H	
	*	5746	102.81	-	-	94.61	32.54	8.33	32.67	137	52	A	H	
														H
														H
														H
			5713.88	50.01	-23.99	74	41.85	32.52	8.3	32.66	100	55	P	V
			5725	71.04	-7.26	78.3	62.84	32.53	8.33	32.66	100	55	P	V
			5714.92	40.73	-13.27	54	32.57	32.52	8.3	32.66	100	55	A	V
		*	5747	105.86	-	-	97.66	32.54	8.33	32.67	100	55	P	V
		*	5747	98.73	-	-	90.53	32.54	8.33	32.67	100	55	A	V
														V
														V
													V	



WIFI Ant. 1	Note	Frequency (MHz)	Level (dBμV/m)	Over Limit (dB)	Limit Line (dBμV/m)	Read Level (dBμV)	Antenna Factor (dB/m)	Cable Loss (dB)	Preamp Factor (dB)	Ant Pos (cm)	Table Pos (deg)	Peak Avg. (P/A)	Pol. (H/V)
802.11n HT20 CH 157 5785MHz		5705.72	48.91	-25.09	74	40.75	32.52	8.3	32.66	134	51	P	H
		5724.84	48.49	-29.81	78.3	40.29	32.53	8.33	32.66	134	51	P	H
		5689.48	40.32	-13.68	54	32.16	32.51	8.3	32.65	134	51	A	H
	*	5783	111.29	-	-	103.05	32.57	8.35	32.68	134	51	P	H
	*	5783	104.5	-	-	96.26	32.57	8.35	32.68	134	51	A	H
		5850.72	47.57	-30.73	78.3	39.23	32.61	8.43	32.7	134	51	P	H
		5861.84	47.99	-26.01	74	39.65	32.62	8.43	32.71	134	51	P	H
		5882.72	39.93	-14.07	54	31.54	32.63	8.47	32.71	134	51	A	H
		5708.76	47.93	-26.07	74	39.77	32.52	8.3	32.66	100	55	P	V
		5715.56	48.54	-29.76	78.3	40.38	32.52	8.3	32.66	100	55	P	V
		5711.56	39.25	-14.75	54	31.09	32.52	8.3	32.66	100	55	A	V
	*	5787	106.39	-	-	98.14	32.58	8.35	32.68	100	55	P	V
	*	5787	99.45	-	-	91.2	32.58	8.35	32.68	100	55	A	V
		5851.84	47.25	-31.05	78.3	38.91	32.61	8.43	32.7	100	55	P	V
		5887.52	48.9	-25.1	74	40.51	32.64	8.47	32.72	100	55	P	V
		5865.84	39.31	-14.69	54	30.97	32.62	8.43	32.71	100	55	A	V



WIFI Ant. 1	Note	Frequency (MHz)	Level (dBμV/m)	Over Limit (dB)	Limit Line (dBμV/m)	Read Level (dBμV)	Antenna Factor (dB/m)	Cable Loss (dB)	Preamp Factor (dB)	Ant Pos (cm)	Table Pos (deg)	Peak Avg. (P/A)	Pol. (H/V)	
802.11n HT20 CH 165 5825MHz	*	5823	112.23	-	-	103.93	32.6	8.39	32.69	135	54	P	H	
	*	5823	105.28	-	-	96.98	32.6	8.39	32.69	135	54	A	H	
		5850.72	71.43	-6.87	78.3	63.09	32.61	8.43	32.7	135	54	P	H	
		5860.01	57.24	-16.76	74	48.9	32.62	8.43	32.71	135	54	P	H	
		5860.96	47.66	-6.34	54	39.32	32.62	8.43	32.71	135	54	A	H	
														H
														H
														H
	*	5823	107.5	-	-	99.2	32.6	8.39	32.69	102	53	P	V	
	*	5823	100.4	-	-	92.1	32.6	8.39	32.69	102	53	A	V	
		5850.56	66.81	-11.49	78.3	58.47	32.61	8.43	32.7	102	53	P	V	
		5860.88	51.55	-22.45	74	43.21	32.62	8.43	32.71	102	53	P	V	
		5860	43.77	-10.23	54	35.43	32.62	8.43	32.71	102	53	A	V	
														V
														V
													V	
Remark	1. No other spurious found. 2. All results are PASS against Peak and Average limit line.													



Band 4 5725~5850MHz

WIFI 802.11n HT20 (Harmonic @ 3m)

WIFI Ant. 1	Note	Frequency (MHz)	Level (dBμV/m)	Over Limit (dB)	Limit Line (dBμV/m)	Read Level (dBμV)	Antenna Factor (dB/m)	Cable Loss (dB)	Preamp Factor (dB)	Ant Pos (cm)	Table Pos (deg)	Peak Avg. (P/A)	Pol. (H/V)
802.11n HT20 CH 149 5745MHz		11490	45.83	-28.17	74	56.04	40.01	12.58	62.8	100	0	P	H
		17232	46.9	-27.1	74	50.38	41.05	15.61	60.14	100	0	P	H
													H
													H
		11490	45.86	-28.14	74	56.07	40.01	12.58	62.8	100	0	P	V
		17232	46.98	-27.02	74	50.46	41.05	15.61	60.14	100	0	P	V
													V
802.11n HT20 CH 157 5785MHz		11570	46.15	-27.85	74	56.35	39.88	12.66	62.74	100	0	P	H
		17352	50.12	-23.88	74	53.2	41.38	15.75	60.21	100	0	P	H
		17352	44.32	-9.68	54	47.4	41.38	15.75	60.21	112	270	A	H
													H
		11570	44.19	-29.81	74	54.39	39.88	12.66	62.74	100	0	P	V
		17352	47.52	-26.48	74	50.6	41.38	15.75	60.21	100	0	P	V
													V
802.11n HT20 CH 165 5825MHz		11650	45.05	-28.95	74	55.26	39.75	12.73	62.69	100	0	P	H
		17475	57.49	-16.51	74	60.13	41.71	15.93	60.28	115	306	P	H
		17475	48.34	-5.66	54	50.98	41.71	15.93	60.28	115	306	A	H
													H
		11650	43.82	-30.18	74	54.03	39.75	12.73	62.69	100	0	P	V
		17477	50.38	-23.62	74	53.02	41.71	15.93	60.28	308	297	P	V
		17477	41.7	-12.3	54	44.34	41.71	15.93	60.28	308	297	A	V
												V	
Remark	1. No other spurious found. 2. All results are PASS against Peak and Average limit line.												



Band 4 5725~5850MHz

WIFI 802.11n HT40 (Band Edge @ 3m)

WIFI Ant. 1	Note	Frequency (MHz)	Level (dBμV/m)	Over Limit (dB)	Limit Line (dBμV/m)	Read Level (dBμV)	Antenna Factor (dB/m)	Cable Loss (dB)	Preamp Factor (dB)	Ant Pos (cm)	Table Pos (deg)	Peak Avg. (P/A)	Pol. (H/V)	
802.11n HT40 CH 151 5755MHz		5713.16	67.15	-1.15	68.3	58.99	32.52	8.3	32.66	134	52	P	H	
		5723.24	72.21	-6.09	78.3	64.01	32.53	8.33	32.66	134	52	P	H	
	*	5757	106.61	-	-	98.39	32.56	8.33	32.67	134	52	P	H	
		5757	98.76	-	-	90.54	32.56	8.33	32.67	134	52	A	H	
		5854.56	49.96	-28.34	78.3	41.61	32.62	8.43	32.7	134	52	P	H	
		5886.4	47.53	-20.77	68.3	39.15	32.63	8.47	32.72	134	52	P	H	
														H
														H
			5714.92	59.75	-8.55	68.3	51.59	32.52	8.3	32.66	101	55	P	V
			5723.16	66.48	-11.82	78.3	58.28	32.53	8.33	32.66	101	55	P	V
		*	5753	101.16	-	-	92.94	32.56	8.33	32.67	101	55	P	V
			5753	94.21	-	-	85.99	32.56	8.33	32.67	101	55	A	V
			5851.44	47.79	-30.51	78.3	39.45	32.61	8.43	32.7	101	55	P	V
			5865.6	47.69	-20.61	68.3	39.35	32.62	8.43	32.71	101	55	P	V
													V	
													V	



WIFI Ant. 1	Note	Frequency (MHz)	Level (dBμV/m)	Over Limit (dB)	Limit Line (dBμV/m)	Read Level (dBμV)	Antenna Factor (dB/m)	Cable Loss (dB)	Preamp Factor (dB)	Ant Pos (cm)	Table Pos (deg)	Peak Avg. (P/A)	Pol. (H/V)
802.11n HT40 CH 159 5795MHz		5691.32	50.05	-23.95	74	41.89	32.51	8.3	32.65	139	51	P	H
		5720.44	49.35	-28.95	78.3	41.18	32.53	8.3	32.66	139	51	P	H
		5700.04	40.97	-13.03	54	32.81	32.51	8.3	32.65	139	51	A	H
	*	5797	110.37	-	-	102.12	32.58	8.35	32.68	139	51	P	H
	*	5797	102.78	-	-	94.53	32.58	8.35	32.68	139	51	A	H
		5850.56	57.1	-21.2	78.3	48.76	32.61	8.43	32.7	139	51	P	H
		5862.32	52.19	-21.81	74	43.85	32.62	8.43	32.71	139	51	P	H
		5860.16	44.05	-9.95	54	35.71	32.62	8.43	32.71	139	51	A	H
		5691.16	48.11	-25.89	74	39.95	32.51	8.3	32.65	100	54	P	V
		5716.6	47.67	-30.63	78.3	39.51	32.52	8.3	32.66	100	54	P	V
		5709.88	39.96	-14.04	54	31.8	32.52	8.3	32.66	100	54	A	V
	*	5793	103.89	-	-	95.64	32.58	8.35	32.68	100	54	P	V
	*	5793	97.95	-	-	89.7	32.58	8.35	32.68	100	54	A	V
		5850.24	52.17	-26.13	78.3	43.83	32.61	8.43	32.7	100	54	P	V
		5870.88	47.84	-26.16	74	39.49	32.63	8.43	32.71	100	54	P	V
	5860.08	40.59	-13.41	54	32.25	32.62	8.43	32.71	100	54	A	V	
Remark	1. No other spurious found. 2. All results are PASS against Peak and Average limit line.												



Band 4 5725~5850MHz

WIFI 802.11n HT40 (Harmonic @ 3m)

WIFI Ant. 1	Note	Frequency (MHz)	Level (dBμV/m)	Over Limit (dB)	Limit Line (dBμV/m)	Read Level (dBμV)	Antenna Factor (dB/m)	Cable Loss (dB)	Preamp Factor (dB)	Ant Pos (cm)	Table Pos (deg)	Peak Avg. (P/A)	Pol. (H/V)	
802.11n HT40 CH 151 5755MHz		11510	44.42	-29.58	74	54.64	40	12.58	62.8	100	0	P	H	
		17267	45	-23.3	68.3	48.35	41.15	15.66	60.16	100	0	P	H	
													H	
													H	
			11510	44.8	-29.2	74	55.02	40	12.58	62.8	100	0	P	V
			17267	43.99	-24.31	68.3	47.34	41.15	15.66	60.16	100	0	P	V
														V
														V
802.11n HT40 CH 159 5795MHz		11590	46.07	-27.93	74	56.3	39.84	12.66	62.73	100	0	P	H	
		17387	48.92	-25.08	74	51.89	41.47	15.79	60.23	100	0	P	H	
													H	
													H	
			11590	44.81	-29.19	74	55.04	39.84	12.66	62.73	100	0	P	V
			17387	45.63	-28.37	74	48.6	41.47	15.79	60.23	100	0	P	V
														V
														V
Remark	1. No other spurious found. 2. All results are PASS against Peak and Average limit line.													



Emission below 1GHz

5GHz WIFI 802.11n HT40 (LF @ 3m)

WIFI	Note	Frequency	Level	Over	Limit	Read	Antenna	Cable	Preamp	Ant	Table	Peak	Pol.	
Ant.				Limit	Line	Level	Factor	Loss	Factor	Pos	Pos	Avg.		
1		(MHz)	(dBμV/m)	(dB)	(dBμV/m)	(dBμV)	(dB/m)	(dB)	(dB)	(cm)	(deg)	(P/A)	(H/V)	
5GHz 802.11n HT40 LF		126.39	28.4	-15.1	43.5	41.81	17.92	1.33	32.66	-	-	P	H	
		189.57	32.49	-11.01	43.5	48.13	15.6	1.48	32.72	103	134	P	H	
		237.09	27.61	-18.39	46	41.09	17.63	1.62	32.73	-	-	P	H	
		501.6	26.24	-19.76	46	32.62	24.21	2.33	32.92	-	-	P	H	
		864.9	29.95	-16.05	46	30.6	28.7	3.16	32.51	-	-	P	H	
		974.8	32.1	-21.9	54	30.21	30	3.38	31.49	-	-	P	H	
														H
														H
														H
														H
														H
														H
														H
														H
			43.23	32.25	-7.75	40	46.13	18.26	0.65	32.79	100	67	P	V
			124.23	24.69	-18.81	43.5	38.32	17.88	1.14	32.65	-	-	P	V
			227.64	26.82	-19.18	46	41.09	16.84	1.62	32.73	-	-	P	V
			552	28.47	-17.53	46	34.44	24.54	2.47	32.98	-	-	P	V
			818	29.95	-16.05	46	31.48	28.18	3.07	32.78	-	-	P	V
			989.5	32.28	-21.72	54	30.23	30	3.38	31.33	-	-	P	V
													V	
													V	
													V	
													V	
													V	
													V	
Remark	1. No other spurious found. 2. All results are PASS against limit line.													



Band 4 5725~5850MHz

WIFI 802.11n HT20 (Band Edge @ 3m)

WIFI Ant. 1+2	Note	Frequency (MHz)	Level (dBμV/m)	Over Limit (dB)	Limit Line (dBμV/m)	Read Level (dBμV)	Antenna Factor (dB/m)	Cable Loss (dB)	Preamp Factor (dB)	Ant Pos (cm)	Table Pos (deg)	Peak Avg. (P/A)	Pol. (H/V)	
802.11n HT20 CH 149 5745MHz		5711.24	54.73	-19.27	74	46.57	32.52	8.3	32.66	203	58	P	H	
		5723.56	77.31	-0.99	78.3	69.11	32.53	8.33	32.66	203	58	P	H	
		5714.68	46.25	-7.75	54	38.09	32.52	8.3	32.66	203	58	A	H	
	*	5747	111.65	-	-	103.45	32.54	8.33	32.67	203	58	P	H	
	*	5747	105	-	-	96.8	32.54	8.33	32.67	203	58	A	H	
														H
														H
														H
			5714.76	52.51	-21.49	74	44.35	32.52	8.3	32.66	162	61	P	V
			5723.88	75.77	-2.53	78.3	67.57	32.53	8.33	32.66	162	61	P	V
			5714.52	44.8	-9.2	54	36.64	32.52	8.3	32.66	162	61	A	V
		*	5743	108.39	-	-	100.19	32.54	8.33	32.67	162	61	P	V
		*	5743	102.18	-	-	93.98	32.54	8.33	32.67	162	61	A	V
														V
													V	
													V	



WIFI Ant. 1+2	Note	Frequency (MHz)	Level (dBμV/m)	Over Limit (dB)	Limit Line (dBμV/m)	Read Level (dBμV)	Antenna Factor (dB/m)	Cable Loss (dB)	Preamp Factor (dB)	Ant Pos (cm)	Table Pos (deg)	Peak Avg. (P/A)	Pol. (H/V)
802.11n HT20 CH 157 5785MHz		5699	50.34	-23.66	74	42.18	32.51	8.3	32.65	162	68	P	H
		5724.2	50.4	-27.9	78.3	42.2	32.53	8.33	32.66	162	68	P	H
		5714.92	40.73	-13.27	54	32.57	32.52	8.3	32.66	162	68	A	H
	*	5787	113.85	-	-	105.6	32.58	8.35	32.68	162	68	P	H
	*	5787	107.31	-	-	99.06	32.58	8.35	32.68	162	68	A	H
		5851.76	49.62	-28.68	78.3	41.28	32.61	8.43	32.7	162	68	P	H
		5863.76	49.18	-24.82	74	40.84	32.62	8.43	32.71	162	68	P	H
		5860.96	39.8	-14.2	54	31.46	32.62	8.43	32.71	162	68	A	H
		5700.04	48.35	-25.65	74	40.19	32.51	8.3	32.65	185	112	P	V
		5719.56	48.93	-29.37	78.3	40.76	32.53	8.3	32.66	185	112	P	V
		5713.56	39.6	-14.4	54	31.44	32.52	8.3	32.66	185	112	A	V
	*	5783	111.51	-	-	103.27	32.57	8.35	32.68	185	112	P	V
	*	5783	105.1	-	-	96.86	32.57	8.35	32.68	185	112	A	V
		5855.28	47.91	-30.39	78.3	39.56	32.62	8.43	32.7	185	112	P	V
		5865.76	48.13	-25.87	74	39.79	32.62	8.43	32.71	185	112	P	V
	5879.04	39.37	-14.63	54	31.02	32.63	8.43	32.71	185	112	A	V	



WIFI Ant. 1+2	Note	Frequency (MHz)	Level (dBμV/m)	Over Limit (dB)	Limit Line (dBμV/m)	Read Level (dBμV)	Antenna Factor (dB/m)	Cable Loss (dB)	Preamp Factor (dB)	Ant Pos (cm)	Table Pos (deg)	Peak Avg. (P/A)	Pol. (H/V)
802.11n HT20 CH 165 5825MHz	*	5827	112.27	-	-	103.97	32.6	8.39	32.69	215	54	P	H
		5827	107.16	-	-	98.86	32.6	8.39	32.69	215	54	A	H
		5850.08	77.43	-0.87	78.3	69.09	32.61	8.43	32.7	215	54	P	H
		5862.16	62.79	-5.51	68.3	54.45	32.62	8.43	32.71	215	54	P	H
													H
													H
													H
													H
	*	5823	111.22	-	-	102.92	32.6	8.39	32.69	195	113	P	V
		5823	104.53	-	-	96.23	32.6	8.39	32.69	195	113	A	V
		5850.24	72.08	-6.22	78.3	63.74	32.61	8.43	32.7	195	113	P	V
		5860.56	61.82	-6.48	68.3	53.48	32.62	8.43	32.71	195	113	P	V
													V
													V
													V
													V
Remark	1. No other spurious found. 2. All results are PASS against Peak and Average limit line.												



Band 4 5725~5850MHz

WIFI 802.11n HT20 (Harmonic @ 3m)

WIFI Ant. 1+2	Note	Frequency (MHz)	Level (dBμV/m)	Over Limit (dB)	Limit Line (dBμV/m)	Read Level (dBμV)	Antenna Factor (dB/m)	Cable Loss (dB)	Preamp Factor (dB)	Ant Pos (cm)	Table Pos (deg)	Peak Avg. (P/A)	Pol. (H/V)	
802.11n HT20 CH 149 5745MHz		11490	47.74	-26.26	74	57.95	40.01	12.58	62.8	100	0	P	H	
		17233	46.16	-27.84	74	49.64	41.05	15.61	60.14	100	0	P	H	
													H	
													H	
			11490	45.83	-28.17	74	56.04	40.01	12.58	62.8	100	0	P	V
			17233	46.75	-27.25	74	50.23	41.05	15.61	60.14	100	0	P	V
														V
802.11n HT20 CH 157 5785MHz		11575	53.36	-20.64	74	63.56	39.88	12.66	62.74	104	360	P	H	
		11575	43.09	-10.91	54	53.29	39.88	12.66	62.74	104	360	A	H	
		17357	56.39	-17.61	74	59.43	41.38	15.79	60.21	113	271	P	H	
		17357	47.7	-6.3	54	50.74	41.38	15.79	60.21	113	271	A	H	
			11568	54.06	-19.94	74	64.26	39.88	12.66	62.74	103	340	P	V
			11568	42.73	-11.27	54	52.93	39.88	12.66	62.74	103	340	A	V
			17352	51.71	-22.29	74	54.79	41.38	15.75	60.21	276	262	P	V
802.11n HT20 CH 165 5825MHz			43.04	-10.96	54	46.12	41.38	15.75	60.21	276	262	A	V	
		11650	59.88	-14.12	74	70.09	39.75	12.73	62.69	278	327	P	H	
		11650	51.7	-2.3	54	61.91	39.75	12.73	62.69	278	327	A	H	
		17472	54.89	-13.41	68.3	57.58	41.71	15.88	60.28	100	0	P	H	
													H	
			11650	58.54	-15.46	74	68.75	39.75	12.73	62.69	150	309	P	V
			11650	49.28	-4.72	54	59.49	39.75	12.73	62.69	150	309	A	V
		17472	52.4	-15.9	68.3	55.09	41.71	15.88	60.28	100	0	P	V	
													V	
Remark	1. No other spurious found. 2. All results are PASS against Peak and Average limit line.													



Band 4 5725~5850MHz

WIFI 802.11n HT40 (Band Edge @ 3m)

WIFI Ant. 1+2	Note	Frequency (MHz)	Level (dBμV/m)	Over Limit (dB)	Limit Line (dBμV/m)	Read Level (dBμV)	Antenna Factor (dB/m)	Cable Loss (dB)	Preamp Factor (dB)	Ant Pos (cm)	Table Pos (deg)	Peak Avg. (P/A)	Pol. (H/V)	
802.11n HT40 CH 151 5755MHz		5714.76	66.45	-1.85	68.3	58.29	32.52	8.3	32.66	155	65	P	H	
		5723.16	74.38	-3.92	78.3	66.18	32.53	8.33	32.66	155	65	P	H	
	*	5753	107.58	-	-	99.36	32.56	8.33	32.67	155	65	P	H	
		5753	100.6	-	-	92.38	32.56	8.33	32.67	155	65	A	H	
		5859.6	47.75	-30.55	78.3	39.41	32.62	8.43	32.71	155	65	P	H	
		5884.56	47.91	-20.39	68.3	39.53	32.63	8.47	32.72	155	65	P	H	
														H
														H
			5714.52	63.35	-4.95	68.3	55.19	32.52	8.3	32.66	100	56	P	V
			5719.16	69.32	-8.98	78.3	61.15	32.53	8.3	32.66	100	56	P	V
	*		5753	103.4	-	-	95.18	32.56	8.33	32.67	100	56	P	V
			5753	97.74	-	-	89.52	32.56	8.33	32.67	100	56	A	V
			5854.4	46.26	-32.04	78.3	37.91	32.62	8.43	32.7	100	56	P	V
			5873.12	48.36	-19.94	68.3	40.01	32.63	8.43	32.71	100	56	P	V
														V
														V



WIFI Ant. 1+2	Note	Frequency (MHz)	Level (dBμV/m)	Over Limit (dB)	Limit Line (dBμV/m)	Read Level (dBμV)	Antenna Factor (dB/m)	Cable Loss (dB)	Preamp Factor (dB)	Ant Pos (cm)	Table Pos (deg)	Peak Avg. (P/A)	Pol. (H/V)	
802.11n HT40 CH 159 5795MHz		5713.8	59.26	-9.04	68.3	51.1	32.52	8.3	32.66	160	61	P	H	
		5724.04	61.14	-17.16	78.3	52.94	32.53	8.33	32.66	160	61	P	H	
	*	5793	111.6	-	-	103.35	32.58	8.35	32.68	160	61	P	H	
		5793	105.02	-	-	96.77	32.58	8.35	32.68	160	61	A	H	
		5850.32	67.42	-10.88	78.3	59.08	32.61	8.43	32.7	160	61	P	H	
		5860.16	65.26	-3.04	68.3	56.92	32.62	8.43	32.71	160	61	P	H	
														H
														H
			5710.12	55.98	-12.32	68.3	47.82	32.52	8.3	32.66	100	53	P	V
			5723.4	57.92	-20.38	78.3	49.72	32.53	8.33	32.66	100	53	P	V
	*		5797	108.54	-	-	100.29	32.58	8.35	32.68	100	53	P	V
			5797	101.36	-	-	93.11	32.58	8.35	32.68	100	53	A	V
			5850.4	62.34	-15.96	78.3	54	32.61	8.43	32.7	100	53	P	V
			5860.16	59.49	-8.81	68.3	51.15	32.62	8.43	32.71	100	53	P	V
														V
													V	
Remark	1. No other spurious found. 2. All results are PASS against Peak and Average limit line.													



Band 4 5725~5850MHz

WIFI 802.11n HT40 (Harmonic @ 3m)

WIFI Ant. 1+2	Note	Frequency (MHz)	Level (dBμV/m)	Over Limit (dB)	Limit Line (dBμV/m)	Read Level (dBμV)	Antenna Factor (dB/m)	Cable Loss (dB)	Preamp Factor (dB)	Ant Pos (cm)	Table Pos (deg)	Peak Avg. (P/A)	Pol. (H/V)	
802.11n HT40 CH 151 5755MHz		11510	46.5	-27.5	74	56.72	40	12.58	62.8	100	0	P	H	
		17268	44.32	-23.98	68.3	47.67	41.15	15.66	60.16	100	0	P	H	
													H	
													H	
			11510	45.47	-28.53	74	55.69	40	12.58	62.8	100	0	P	V
			17268	43.72	-24.58	68.3	47.07	41.15	15.66	60.16	100	0	P	V
														V
802.11n HT40 CH 159 5795MHz		11590	53.96	-20.04	74	64.19	39.84	12.66	62.73	100	360	P	H	
		11590	44.64	-9.36	54	54.87	39.84	12.66	62.73	100	360	A	H	
		17385	51.99	-16.31	68.3	54.96	41.47	15.79	60.23	100	0	P	H	
													H	
			11590	51.08	-22.92	74	61.31	39.84	12.66	62.73	100	91	P	V
			11590	43.45	-10.55	54	53.68	39.84	12.66	62.73	100	91	A	V
			17388	48.85	-19.45	68.3	51.82	41.47	15.79	60.23	100	0	P	V
													V	
Remark	1. No other spurious found. 2. All results are PASS against Peak and Average limit line.													



Emission below 1GHz

5GHz WIFI 802.11n HT20 (LF @ 3m)

WIFI	Note	Frequency	Level	Over	Limit	Read	Antenna	Cable	Preamp	Ant	Table	Peak	Pol.	
Ant.				Limit	Line	Level	Factor	Loss	Factor	Pos	Pos	Avg.		
1+2		(MHz)	(dBμV/m)	(dB)	(dBμV/m)	(dBμV)	(dB/m)	(dB)	(dB)	(cm)	(deg)	(P/A)	(H/V)	
5GHz 802.11n HT20 LF		126.66	30.84	-12.66	43.5	44.23	17.94	1.33	32.66	-	-	P	H	
		189.84	35.23	-8.27	43.5	50.87	15.6	1.48	32.72	105	164	P	H	
		237.63	29.49	-16.51	46	42.88	17.72	1.62	32.73	-	-	P	H	
		499.5	29.14	-16.86	46	35.55	24.18	2.33	32.92	-	-	P	H	
		897.8	32.68	-13.32	46	33.1	28.7	3.2	32.32	-	-	P	H	
		965.7	34.89	-19.11	54	33.09	30	3.38	31.58	-	-	P	H	
														H
														H
														H
														H
														H
														H
			43.77	34.8	-5.2	40	48.68	18.26	0.65	32.79	100	56	P	V
			190.65	27.68	-15.82	43.5	43.28	15.64	1.48	32.72	-	-	P	V
			230.61	30.08	-15.92	46	44.1	17.09	1.62	32.73	-	-	P	V
			551.3	31.33	-14.67	46	37.32	24.52	2.47	32.98	-	-	P	V
			775.3	31.33	-14.67	46	33.57	27.7	2.97	32.91	-	-	P	V
			999.3	33.64	-20.36	54	31.48	30	3.38	31.22	-	-	P	V
														V
														V
													V	
													V	
													V	
													V	
Remark	1. No other spurious found. 2. All results are PASS against limit line.													



Note symbol

*	Fundamental Frequency which can be ignored. However, the level of any unwanted emissions shall not exceed the level of the fundamental frequency.
!	Test result is over limit line.
P/A	Peak or Average
H/V	Horizontal or Vertical



A calculation example for radiated spurious emission is shown as below:

WIFI	Note	Frequency	Level	Over	Limit	Read	Antenna	Cable	Preamp	Ant	Table	Peak	Pol.
Ant.				Limit	Line	Level	Factor	Loss	Factor	Pos	Pos	Avg.	
1+2		(MHz)	(dBμV/m)	(dB)	(dBμV/m)	(dBμV)	(dB/m)	(dB)	(dB)	(cm)	(deg)	(P/A)	(H/V)
802.11b		2390	55.45	-18.55	74	54.51	32.22	4.58	35.86	103	308	P	H
CH 01													
2412MHz		2390	43.54	-10.46	54	42.6	32.22	4.58	35.86	103	308	A	H

- Level(dBμV/m) =
Antenna Factor(dB/m) + Cable Loss(dB) + Read Level(dBμV) - Preamp Factor(dB)
- Over Limit(dB) = Level(dBμV/m) – Limit Line(dBμV/m)

For Peak Limit @ 2390MHz:

- Level(dBμV/m)
= Antenna Factor(dB/m) + Cable Loss(dB) + Read Level(dBμV) - Preamp Factor(dB)
= 32.22(dB/m) + 4.58(dB) + 54.51(dBμV) – 35.86 (dB)
= 55.45 (dBμV/m)
- Over Limit(dB)
= Level(dBμV/m) – Limit Line(dBμV/m)
= 55.45(dBμV/m) – 74(dBμV/m)
= -18.55(dB)

For Average Limit @ 2390MHz:

- Level(dBμV/m)
= Antenna Factor(dB/m) + Cable Loss(dB) + Read Level(dBμV) - Preamp Factor(dB)
= 32.22(dB/m) + 4.58(dB) + 42.6(dBμV) – 35.86 (dB)
= 43.54 (dBμV/m)
- Over Limit(dB)
= Level(dBμV/m) – Limit Line(dBμV/m)
= 43.54(dBμV/m) – 54(dBμV/m)
= -10.46(dB)

Both peak and average measured complies with the limit line, so test result is “PASS”.



Appendix C. Radiated Spurious Emission Plots

Test Engineer :	Stan Hsieh, Nick Yu, and Tsung Lee	Temperature :	22~25°C
		Relative Humidity :	45~48%

Note symbol

-L	Low channel location
-R	High channel location



Band 4 - 5725~5850MHz
WIFI 802.11a (Fundamental @ 3m)

Table with 2 columns: Horizontal and Vertical. Contains spectral plots and technical details for Peak/Avg. measurements at 5745MHz.

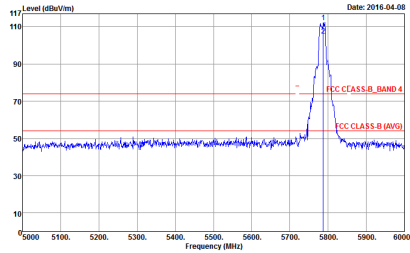
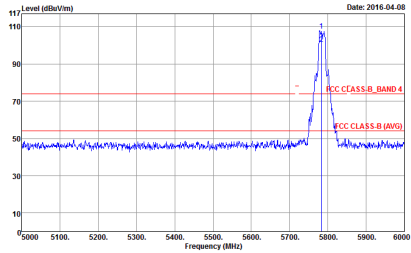

WIFI	Band 4 5725~5850MHz Fundamental @ 3m	
ANT	802.11a CH157 5785MHz	
1	Horizontal	Vertical
Peak / Avg.	 <p>Date: 2016-04-08</p> <p>Site : 03CH10-HY Condition : FCC CLASS-B_BAND 4 3m HORN 9120D-HF HORIZONTAL RBW:1000.000KHz VBW:3000.000KHz SWT:Auto Detector : Peak Project : 273180-08 Mode : 2</p>	 <p>Date: 2016-04-08</p> <p>Site : 03CH10-HY Condition : FCC CLASS-B_BAND 4 3m HORN 9120D-HF VERTICAL RBW:1000.000KHz VBW:3000.000KHz SWT:Auto Detector : Peak Project : 273180-08 Mode : 2</p>

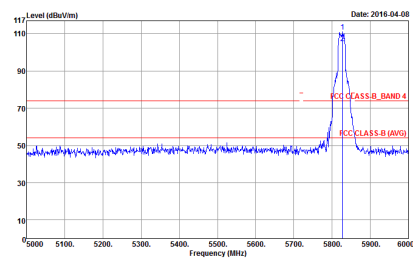
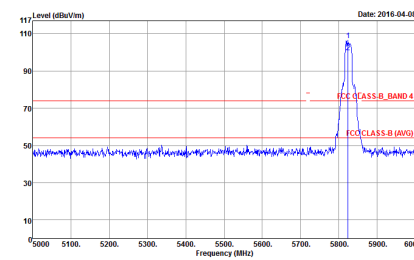

WIFI	Band 4 5725~5850MHz Fundamental @ 3m	
ANT	802.11a CH165 5825MHz	
1	Horizontal	Vertical
Peak / Avg.	 <p>Date: 2016-04-08</p> <p>Site : 03CH10-HY Condition : FCC CLASS-B_BAND 4 3m HORN 9120D-HF HORIZONTAL RBW:1000.000KHz VBW:3000.000KHz SWT:Auto Detector : Peak Project : 273180-08 Mode : 3</p>	 <p>Date: 2016-04-08</p> <p>Site : 03CH10-HY Condition : FCC CLASS-B_BAND 4 3m HORN 9120D-HF VERTICAL RBW:1000.000KHz VBW:3000.000KHz SWT:Auto Detector : Peak Project : 273180-08 Mode : 3</p>



Band 4 5725~5850MHz

WIFI 802.11n HT20 (Fundamental @ 3m)

WIFI	Band 4 5725~5850MHz Fundamental @ 3m	
ANT	802.11n HT20 CH149 5745MHz	
1	Horizontal	Vertical
Peak / Avg.	<p>Site : 03CH10-HY Condition : FCC CLASS-B_BAND 4 3m HORN 9120D-HF HORIZONTAL RBW:1000.000KHz VBW:3000.000KHz SWT:Auto Detector : Peak Project : 273180-08 Mode : 4</p>	<p>Site : 03CH10-HY Condition : FCC CLASS-B_BAND 4 3m HORN 9120D-HF VERTICAL RBW:1000.000KHz VBW:3000.000KHz SWT:Auto Detector : Peak Project : 273180-08 Mode : 4</p>

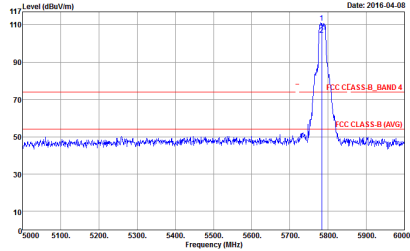
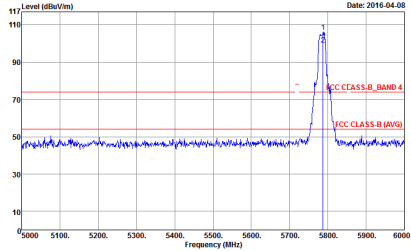

WIFI	Band 4 5725~5850MHz Fundamental @ 3m	
ANT	802.11n HT20 CH157 5785MHz	
1	Horizontal	Vertical
Peak / Avg.	 <p>Site : 03CH10-HY Condition : FCC CLASS-B_BAND 4 3m HORN 9120D-HF HORIZONTAL Detector : Peak Project : 273180-08 Mode : 5</p>	 <p>Site : 03CH10-HY Condition : FCC CLASS-B_BAND 4 3m HORN 9120D-HF VERTICAL Detector : Peak Project : 273180-08 Mode : 5</p>

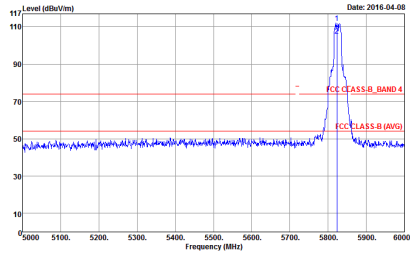
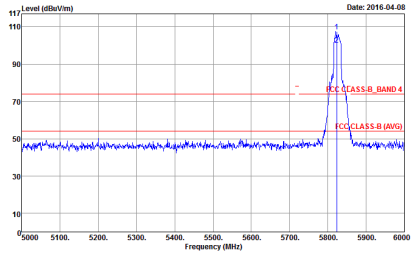

WIFI	Band 4 5725~5850MHz Fundamental @ 3m	
ANT	802.11n HT20 CH165 5825MHz	
1	Horizontal	Vertical
Peak / Avg.	 <p>Site : 03CH10-HY Condition : FCC CLASS-B_BAND 4 3m HORN 9120D-HF HORIZONTAL Detector : Peak Project : 273180-08 Mode : 6</p>	 <p>Site : 03CH10-HY Condition : FCC CLASS-B_BAND 4 3m HORN 9120D-HF VERTICAL Detector : Peak Project : 273180-08 Mode : 6</p>



Band 4 5725~5850MHz

WIFI 802.11n HT40 (Fundamental @ 3m)

WIFI	Band 4 5725~5850MHz Fundamental @ 3m	
ANT	802.11n HT40 CH151 5755MHz	
1	Horizontal	Vertical
Peak / Avg.	<p> Site : 03CH10-HY Condition : FCC PART 15E_BAND4 3m HORN 9120D-HF HORIZONTAL Detector : Peak Project : 273180-08 Mode : 7 </p>	<p> Site : 03CH10-HY Condition : FCC PART 15E_BAND4 3m HORN 9120D-HF VERTICAL Detector : Peak Project : 273180-08 Mode : 7 </p>

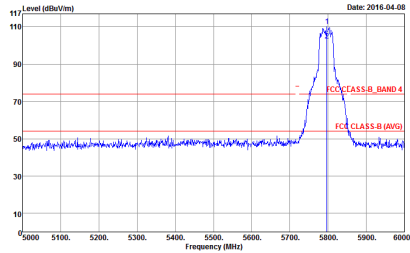
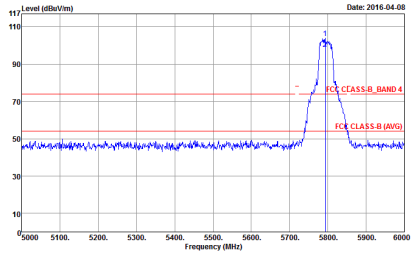

WIFI	Band 4 5725~5850MHz Fundamental @ 3m	
ANT	802.11n HT40 CH159 5795MHz	
1	Horizontal	Vertical
Peak / Avg.	 <p>Site : 03CH10-HY Condition : FCC CLASS-B_BAND 4 3m HORN 9120D-HF HORIZONTAL Detector : Peak Project : 273180-08 Mode : 8</p>	 <p>Site : 03CH10-HY Condition : FCC CLASS-B_BAND 4 3m HORN 9120D-HF VERTICAL Detector : Peak Project : 273180-08 Mode : 8</p>

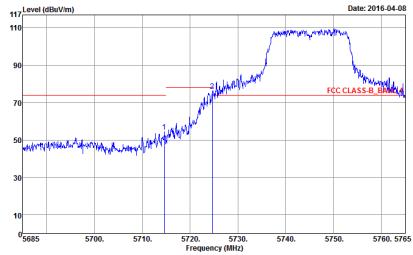
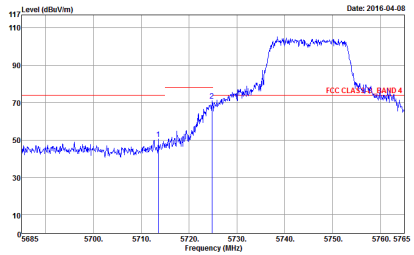
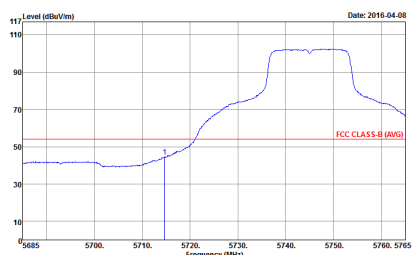
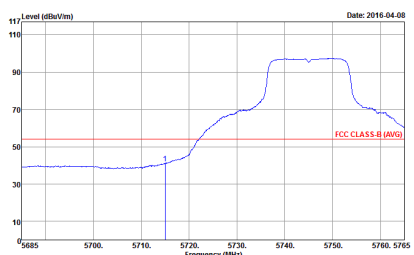

Band 4 - 5725~5850MHz
WIFI 802.11a (Band Edge @ 3m)

WIFI	Band 4 5725~5850MHz Band Edge @ 3m	
ANT	802.11a CH149 5745MHz	
1	Horizontal	Vertical
<p>Peak</p>	 <p>Site : 03CH10-HY Condition : FCC CLASS-B_BAND 4 3m HORN 9120D-HF HORIZONTAL Detector : Peak Project : 273180-08 Mode : 1</p>	 <p>Site : 03CH10-HY Condition : FCC CLASS-B_BAND 4 3m HORN 9120D-HF VERTICAL Detector : Peak Project : 273180-08 Mode : 1</p>
<p>Avg.</p>	 <p>Site : 03CH10-HY Condition : FCC CLASS-B (AVG) 3m HORN 9120D-HF HORIZONTAL Detector : Peak Project : 273180-08 Mode : 1</p>	 <p>Site : 03CH10-HY Condition : FCC CLASS-B (AVG) 3m HORN 9120D-HF VERTICAL Detector : Peak Project : 273180-08 Mode : 1</p>

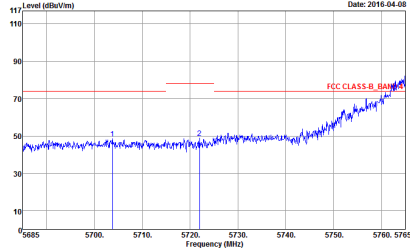
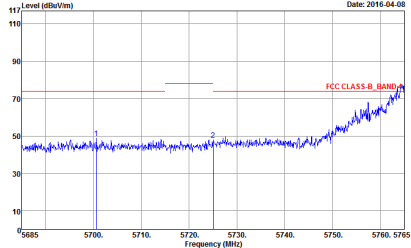
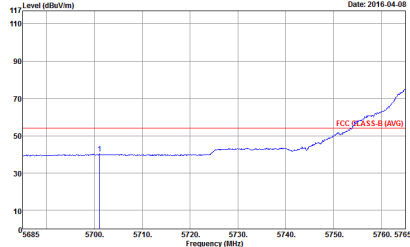
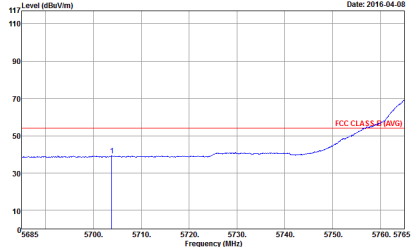

WIFI	Band 4 5725~5850MHz Band Edge @ 3m	
ANT	802.11a CH157 5785MHz - L	
1	Horizontal	Vertical
<p>Peak</p>	 <p>Date: 2016-04-08</p> <p>Site : 03CH10-HY Condition : FCC CLASS-B_BAND 4 3m HORN 9120D-HF HORIZONTAL Detector : Peak Project : 273180-08 Mode : 2</p>	 <p>Date: 2016-04-08</p> <p>Site : 03CH10-HY Condition : FCC CLASS-B_BAND 4 3m HORN 9120D-HF VERTICAL Detector : Peak Project : 273180-08 Mode : 2</p>
<p>Avg.</p>	 <p>Date: 2016-04-08</p> <p>Site : 03CH10-HY Condition : FCC CLASS-B (AVG) 3m HORN 9120D-HF HORIZONTAL Detector : Peak Project : 273180-08 Mode : 2</p>	 <p>Date: 2016-04-08</p> <p>Site : 03CH10-HY Condition : FCC CLASS-B (AVG) 3m HORN 9120D-HF VERTICAL Detector : Peak Project : 273180-08 Mode : 2</p>

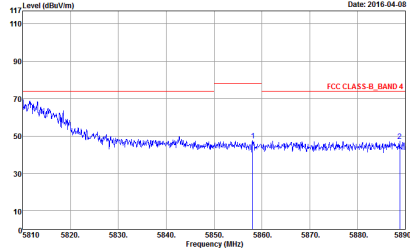
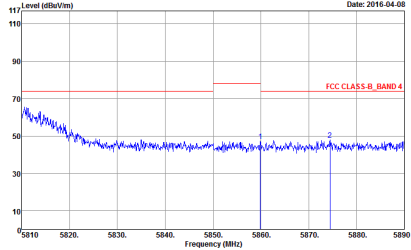
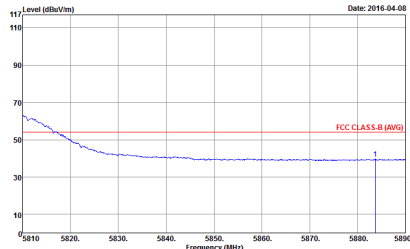
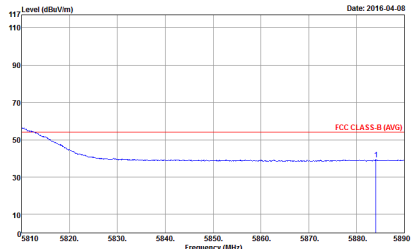

WIFI	Band 4 5725~5850MHz Band Edge @ 3m	
ANT	802.11a CH157 5785MHz - R	
1	Horizontal	Vertical
Peak	 <p>Date: 2016-04-08</p> <p>Site : 03CH10-HY Condition : FCC CLASS-B_BAND 4 3m HORN 9120D-HF HORIZONTAL RBW:1000.000KHz VBW:3000.000KHz SWT:Auto Detector : Peak Project : 273180-08 Mode : 2</p>	 <p>Date: 2016-04-08</p> <p>Site : 03CH10-HY Condition : FCC CLASS-B_BAND 4 3m HORN 9120D-HF VERTICAL RBW:1000.000KHz VBW:3000.000KHz SWT:Auto Detector : Peak Project : 273180-08 Mode : 2</p>
Avg.	 <p>Date: 2016-04-08</p> <p>Site : 03CH10-HY Condition : FCC CLASS-B (AVG) 3m HORN 9120D-HF HORIZONTAL RBW:1000.000KHz VBW:1000KHz SWT:Auto Detector : Peak Project : 273180-08 Mode : 2</p>	 <p>Date: 2016-04-08</p> <p>Site : 03CH10-HY Condition : FCC CLASS-B (AVG) 3m HORN 9120D-HF VERTICAL RBW:1000.000KHz VBW:1000KHz SWT:Auto Detector : Peak Project : 273180-08 Mode : 2</p>

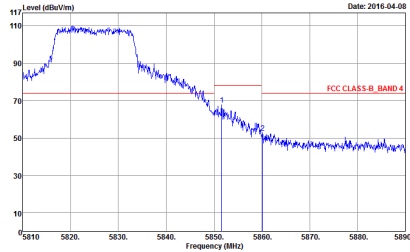
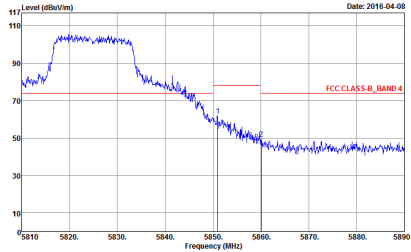
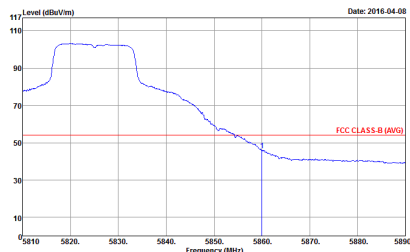
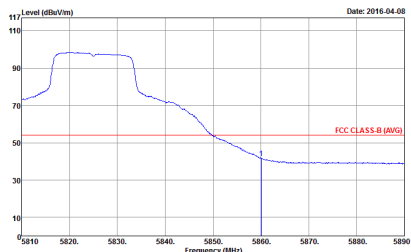

WIFI	Band 4 5725~5850MHz Band Edge @ 3m	
ANT	802.11a CH165 5825MHz	
1	Horizontal	Vertical
Peak	 <p>Date: 2016-04-08</p> <p>Site : 03CH10-HY Condition : FCC CLASS-B_BAND 4 3m HORN 9120D-HF HORIZONTAL RBW:1000.000KHz VBW:3000.000KHz SWT:Auto Detector : Peak Project : 273180-08 Mode : 3</p>	 <p>Date: 2016-04-08</p> <p>Site : 03CH10-HY Condition : FCC CLASS-B_BAND 4 3m HORN 9120D-HF VERTICAL RBW:1000.000KHz VBW:3000.000KHz SWT:Auto Detector : Peak Project : 273180-08 Mode : 3</p>
Avg.	 <p>Date: 2016-04-08</p> <p>Site : 03CH10-HY Condition : FCC CLASS-B (AVG) 3m HORN 9120D-HF HORIZONTAL RBW:1000.000KHz VBW:1000KHz SWT:Auto Detector : Peak Project : 273180-08 Mode : 3</p>	 <p>Date: 2016-04-08</p> <p>Site : 03CH10-HY Condition : FCC CLASS-B (AVG) 3m HORN 9120D-HF VERTICAL RBW:1000.000KHz VBW:1000KHz SWT:Auto Detector : Peak Project : 273180-08 Mode : 3</p>

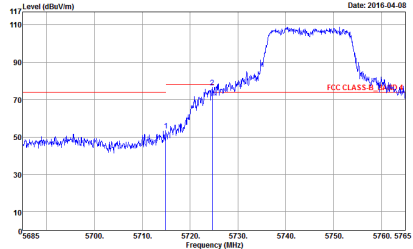
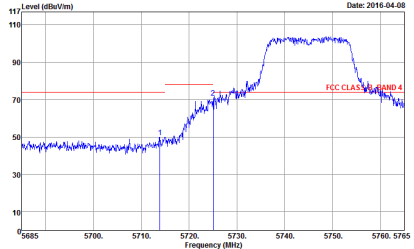
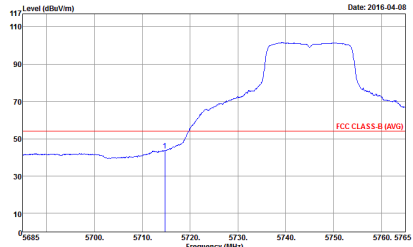
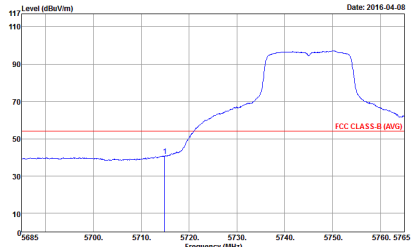

Band 4 5725~5850MHz
WIFI 802.11n HT20 (Band Edge @ 3m)

WIFI	Band 4 5725~5850MHz Band Edge @ 3m	
ANT	802.11n HT20 CH149 5745MHz	
1	Horizontal	Vertical
Peak	 <p>Site : 03CH10-HY Condition : FCC CLASS-B_BAND 4 3m HORN 9120D-HF HORIZONTAL Detector : Peak Project : 273180-08 Mode : 4</p>	 <p>Site : 03CH10-HY Condition : FCC CLASS-B_BAND 4 3m HORN 9120D-HF VERTICAL Detector : Peak Project : 273180-08 Mode : 4</p>
Avg.	 <p>Site : 03CH10-HY Condition : FCC CLASS-B (AVG) 3m HORN 9120D-HF HORIZONTAL Detector : Peak Project : 273180-08 Mode : 4</p>	 <p>Site : 03CH10-HY Condition : FCC CLASS-B (AVG) 3m HORN 9120D-HF VERTICAL Detector : Peak Project : 273180-08 Mode : 4</p>

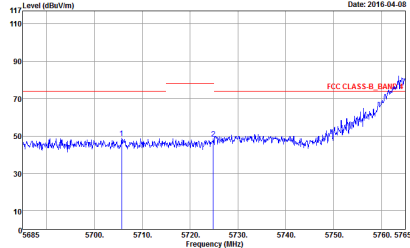
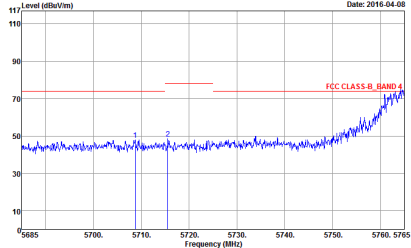
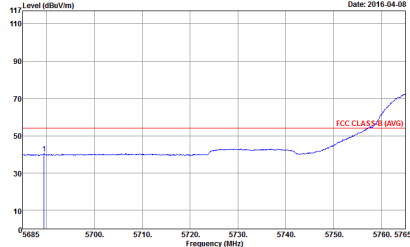
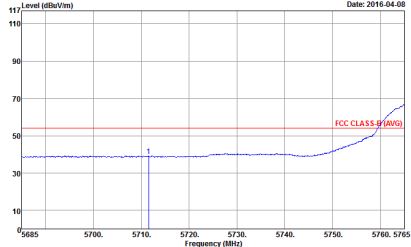

WIFI	Band 4 5725~5850MHz Band Edge @ 3m	
ANT	802.11n HT20 CH157 5785MHz - L	
1	Horizontal	Vertical
Peak	 <p>Date: 2016-04-08</p> <p>Site : 03CH10-HY Condition : FCC CLASS-B_BAND 4 3m HORN 9120D-HF HORIZONTAL Detector : Peak Project : 273180-08 Mode : 5</p>	 <p>Date: 2016-04-08</p> <p>Site : 03CH10-HY Condition : FCC CLASS-B_BAND 4 3m HORN 9120D-HF VERTICAL Detector : Peak Project : 273180-08 Mode : 5</p>
Avg.	 <p>Date: 2016-04-08</p> <p>Site : 03CH10-HY Condition : FCC CLASS-B (AVG) 3m HORN 9120D-HF HORIZONTAL Detector : Peak Project : 273180-08 Mode : 5</p>	 <p>Date: 2016-04-08</p> <p>Site : 03CH10-HY Condition : FCC CLASS-B (AVG) 3m HORN 9120D-HF VERTICAL Detector : Peak Project : 273180-08 Mode : 5</p>

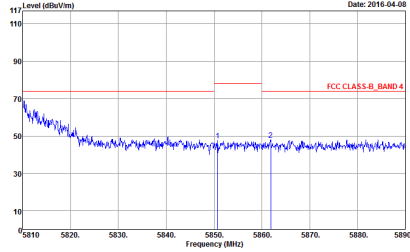
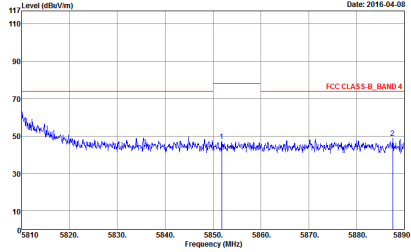
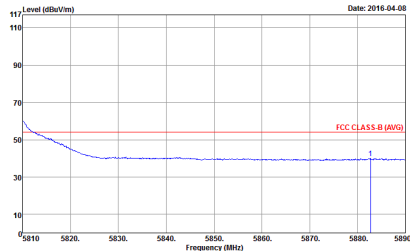
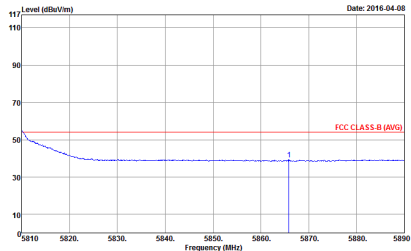

WIFI	Band 4 5725~5850MHz Band Edge @ 3m	
ANT	802.11n HT20 CH157 5785MHz - R	
1	Horizontal	Vertical
Peak	 <p>Date: 2016-04-08</p> <p>Site : 03CH10-HY Condition : FCC CLASS-B_BAND 4 3m HORN 9120D-HF HORIZONTAL RBW:1000.000KHz VBW:3000.000KHz SWT:Auto Detector : Peak Project : 273180-08 Mode : 5</p>	 <p>Date: 2016-04-08</p> <p>Site : 03CH10-HY Condition : FCC CLASS-B_BAND 4 3m HORN 9120D-HF VERTICAL RBW:1000.000KHz VBW:3000.000KHz SWT:Auto Detector : Peak Project : 273180-08 Mode : 5</p>
Avg.	 <p>Date: 2016-04-08</p> <p>Site : 03CH10-HY Condition : FCC CLASS-B (AVG) 3m HORN 9120D-HF HORIZONTAL RBW:1000.000KHz VBW:1000KHz SWT:Auto Detector : Peak Project : 273180-08 Mode : 5</p>	 <p>Date: 2016-04-08</p> <p>Site : 03CH10-HY Condition : FCC CLASS-B (AVG) 3m HORN 9120D-HF VERTICAL RBW:1000.000KHz VBW:1000KHz SWT:Auto Detector : Peak Project : 273180-08 Mode : 5</p>

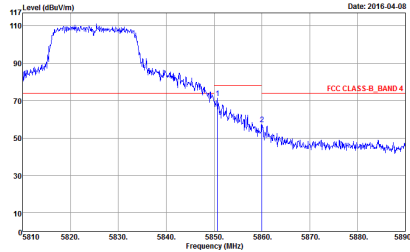
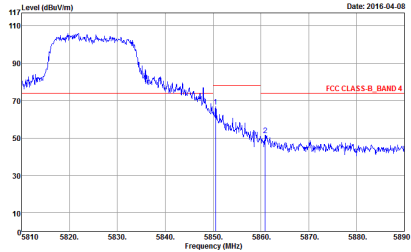
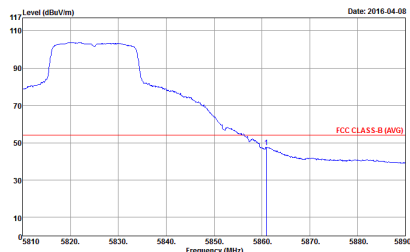
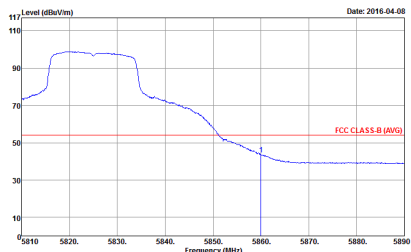

WIFI	Band 4 5725~5850MHz Band Edge @ 3m	
ANT	802.11n HT20 CH165 5825MHz	
1	Horizontal	Vertical
Peak	 <p>Date: 2016-04-08</p> <p>Site : 03CH10-HY Condition : FCC CLASS-B_BAND 4 3m HORN 9120D-HF HORIZONTAL RBW:1000.000KHz VBW:3000.000KHz SWT:Auto Detector : Peak Project : 273180-08 Mode : 6</p>	 <p>Date: 2016-04-08</p> <p>Site : 03CH10-HY Condition : FCC CLASS-B_BAND 4 3m HORN 9120D-HF VERTICAL RBW:1000.000KHz VBW:3000.000KHz SWT:Auto Detector : Peak Project : 273180-08 Mode : 6</p>
Avg.	 <p>Date: 2016-04-08</p> <p>Site : 03CH10-HY Condition : FCC CLASS-B (AVG) 3m HORN 9120D-HF HORIZONTAL RBW:1000.000KHz VBW:1000KHz SWT:Auto Detector : Peak Project : 273180-08 Mode : 6</p>	 <p>Date: 2016-04-08</p> <p>Site : 03CH10-HY Condition : FCC CLASS-B (AVG) 3m HORN 9120D-HF VERTICAL RBW:1000.000KHz VBW:1000KHz SWT:Auto Detector : Peak Project : 273180-08 Mode : 6</p>



Band 4 5725~5850MHz
WIFI 802.11n HT40 (Band Edge @ 3m)

Table with 2 columns: Horizontal and Vertical. It contains two spectral plots showing Level (dBuV/m) vs Frequency (MHz) for a Peak at 802.11n HT40 CH151 5755MHz - L. The plots show a signal rising from ~50 dBuV/m at 5700 MHz to ~100 dBuV/m at 5755 MHz, with a red line indicating the FCC Part 15E Band4 limit at 70 dBuV/m.

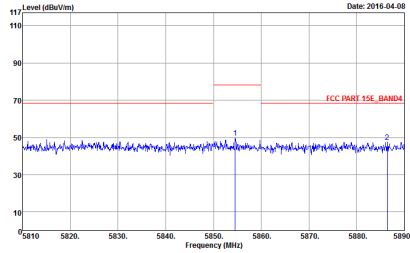
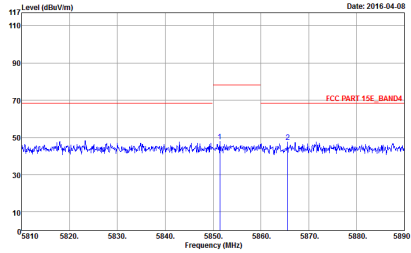

WIFI	Band 4 5725~5850MHz Band Edge @ 3m	
ANT	802.11n HT40 CH151 5755MHz - R	
1	Horizontal	Vertical
Peak	 <p>Site : 03CH10-HY Condition : FCC PART 15E_BAND4 3m HORN 9120D-HF HORIZONTAL Detector : Peak Project : 273180-08 Mode : 7</p>	 <p>Site : 03CH10-HY Condition : FCC PART 15E_BAND4 3m HORN 9120D-HF VERTICAL Detector : Peak Project : 273180-08 Mode : 7</p>

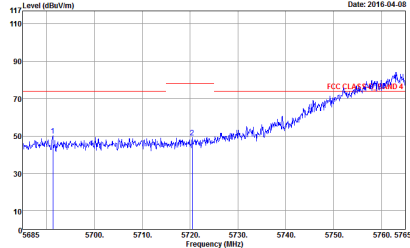
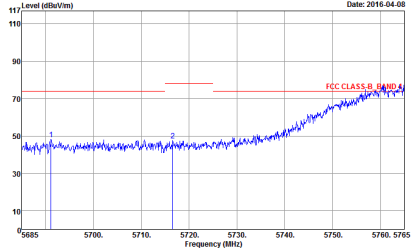
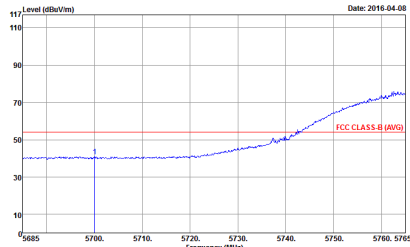
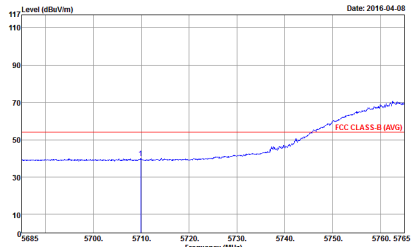

WIFI	Band 4 5725~5850MHz Band Edge @ 3m	
ANT	802.11n HT40 CH159 5795MHz - L	
1	Horizontal	Vertical
Peak	 <p>Date: 2016-04-08</p> <p>Site : 03CH10-HY Condition : FCC CLASS-B_BAND 4 3m HORN 9120D-HF HORIZONTAL Detector : Peak Project : 273180-08 Mode : 8</p>	 <p>Date: 2016-04-08</p> <p>Site : 03CH10-HY Condition : FCC CLASS-B_BAND 4 3m HORN 9120D-HF VERTICAL Detector : Peak Project : 273180-08 Mode : 8</p>
Avg.	 <p>Date: 2016-04-08</p> <p>Site : 03CH10-HY Condition : FCC CLASS-B (AVG) 3m HORN 9120D-HF HORIZONTAL Detector : Peak Project : 273180-08 Mode : 8</p>	 <p>Date: 2016-04-08</p> <p>Site : 03CH10-HY Condition : FCC CLASS-B (AVG) 3m HORN 9120D-HF VERTICAL Detector : Peak Project : 273180-08 Mode : 8</p>

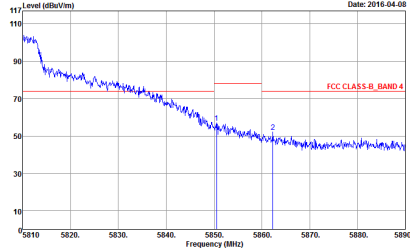
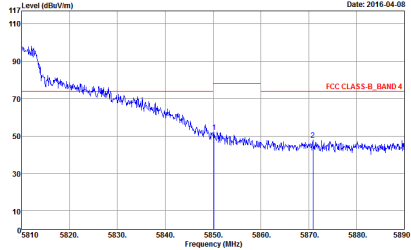
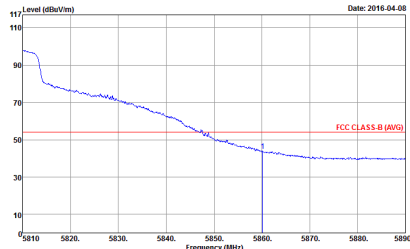
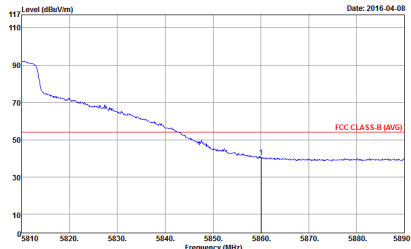

WIFI	Band 4 5725~5850MHz Band Edge @ 3m	
ANT	802.11n HT40 CH159 5795MHz - R	
1	Horizontal	Vertical
Peak	 <p>Date: 2016-04-08</p> <p>Site : 03CH10-HY Condition : FCC CLASS-B_BAND 4 3m HORN 9120D-HF HORIZONTAL RBW:1000.000KHz VBW:3000.000KHz SWT:Auto Detector : Peak Project : 273180-08 Mode : 8</p>	 <p>Date: 2016-04-08</p> <p>Site : 03CH10-HY Condition : FCC CLASS-B_BAND 4 3m HORN 9120D-HF VERTICAL RBW:1000.000KHz VBW:3000.000KHz SWT:Auto Detector : Peak Project : 273180-08 Mode : 8</p>
Avg.	 <p>Date: 2016-04-08</p> <p>Site : 03CH10-HY Condition : FCC CLASS-B (AVG) 3m HORN 9120D-HF HORIZONTAL RBW:1000.000KHz VBW:3.000KHz SWT:Auto Detector : Peak Project : 273180-08 Mode : 8</p>	 <p>Date: 2016-04-08</p> <p>Site : 03CH10-HY Condition : FCC CLASS-B (AVG) 3m HORN 9120D-HF VERTICAL RBW:1000.000KHz VBW:3.000KHz SWT:Auto Detector : Peak Project : 273180-08 Mode : 8</p>



Band 4 - 5725~5850MHz
WIFI 802.11a (Harmonic @ 3m)

Table with 2 columns: Horizontal and Vertical. It contains two spectral plots showing Level (dBuV/m) vs Frequency (MHz) for Peak and Avg. measurements. The plots show two peaks at approximately 12000 MHz and 16000 MHz, both well below the FCC Class-B Band 4 limits.

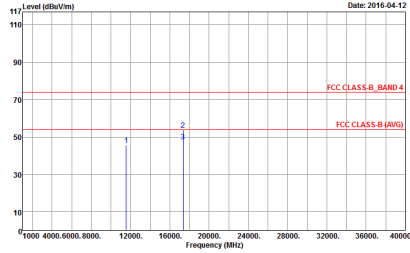
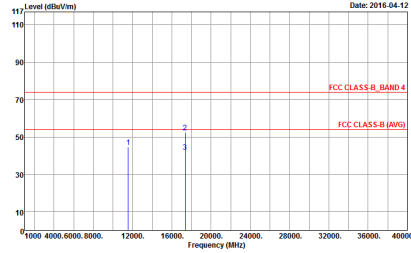

WIFI	Band 4 5725-5850MHz Harmonic @ 3m	
ANT	802.11a CH157 5785MHz	
1	Horizontal	Vertical
<p>Peak</p> <p>Avg.</p>	 <p style="font-size: small;">Date: 2016-04-12</p> <p style="font-size: x-small;">Site : 03CH10-HY Condition : FCC CLASS-B_BAND 4 3m HORN 9120D-HF HORIZONTAL Detector : Peak Project : Z73180-08 Mode : 2</p>	 <p style="font-size: small;">Date: 2016-04-12</p> <p style="font-size: x-small;">Site : 03CH10-HY Condition : FCC CLASS-B_BAND 4 3m HORN 9120D-HF VERTICAL Detector : Peak Project : Z73180-08 Mode : 2</p>

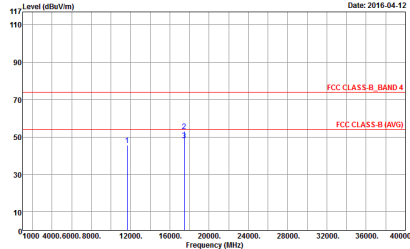
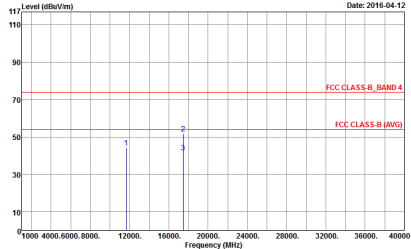

WIFI	Band 4 5725-5850MHz Harmonic @ 3m	
ANT	802.11a CH165 5825MHz	
1	Horizontal	Vertical
Peak Avg.	 <p style="font-size: small;">Date: 2016-04-12</p> <p style="font-size: x-small;">Site : 03CH10-HY Condition : FCC CLASS-B_BAND 4 3m HORN 9120D-HF HORIZONTAL Detector : Peak Project : Z73180-08 Mode : 3</p>	 <p style="font-size: small;">Date: 2016-04-12</p> <p style="font-size: x-small;">Site : 03CH10-HY Condition : FCC CLASS-B_BAND 4 3m HORN 9120D-HF VERTICAL Detector : Peak Project : Z73180-08 Mode : 3</p>

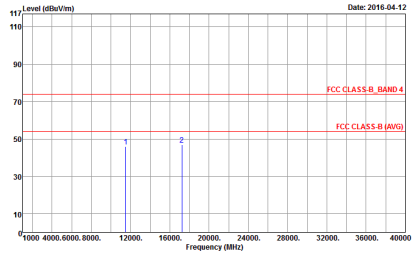
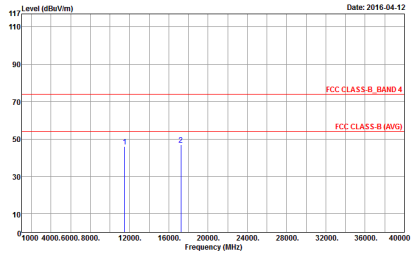

Band 4 5725~5850MHz
WIFI 802.11n HT20 (Harmonic @ 3m)

WIFI	Band 4 5725~5850MHz Harmonic @ 3m	
ANT	802.11n HT20 CH149 5745MHz	
1	Horizontal	Vertical
Peak Avg.	 <p>Date: 2016-04-12</p> <p>Site : 03CH10-HY Condition : FCC CLASS-B_BAND 4 3m HORN 9120D-HF HORIZONTAL Detector : Peak Project : Z73180-08 Mode : 4</p>	 <p>Date: 2016-04-12</p> <p>Site : 03CH10-HY Condition : FCC CLASS-B_BAND 4 3m HORN 9120D-HF VERTICAL Detector : Peak Project : Z73180-08 Mode : 4</p>

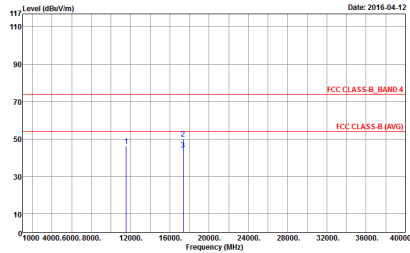
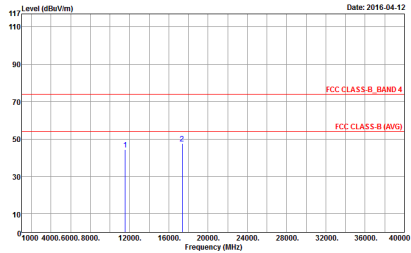

WIFI	Band 4 5725-5850MHz Harmonic @ 3m	
ANT	802.11n HT20 CH157 5785MHz	
1	Horizontal	Vertical
Peak Avg.	 <p>Date: 2016-04-12</p> <p>Site : 03CH10-HY Condition : FCC CLASS-B_BAND 4 3m HORN 9120D-HF HORIZONTAL Detector : Peak Project : Z73180-08 Mode : 5</p>	 <p>Date: 2016-04-12</p> <p>Site : 03CH10-HY Condition : FCC CLASS-B_BAND 4 3m HORN 9120D-HF VERTICAL Detector : Peak Project : Z73180-08 Mode : 5</p>



WIFI	Band 4 5725~5850MHz Harmonic @ 3m	
ANT	802.11n HT20 CH165 5825MHz	
1	Horizontal	Vertical
<p>Peak</p> <p>Avg.</p>	<p style="font-size: small;">Date: 2016-04-11</p> <p style="font-size: x-small;">Site : 03CH10-HY Condition : FCC CLASS-B_BAND 4 3m HORN 9120D-HF HORIZONTAL Detector : Peak Project : Z73180-08 Mode : 6</p>	<p style="font-size: small;">Date: 2016-04-11</p> <p style="font-size: x-small;">Site : 03CH10-HY Condition : FCC CLASS-B_BAND 4 3m HORN 9120D-HF VERTICAL Detector : Peak Project : Z73180-08 Mode : 6</p>

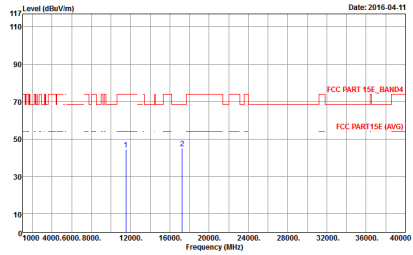
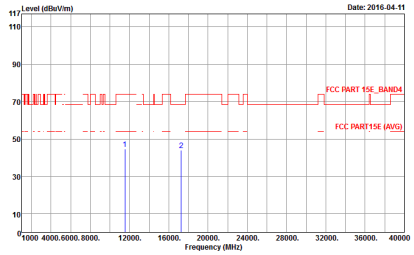

**Band 4 5725~5850MHz
WIFI 802.11n HT40 (Harmonic @ 3m)**

WIFI	Band 4 5725~5850MHz Harmonic @ 3m	
ANT	802.11n HT40 CH151 5755MHz	
1	Horizontal	Vertical
<p>Peak</p> <p>Avg.</p>	 <p>Site : 03CH10-HY Condition : FCC PART 15E_BAND4 3m HORN 9120D-HF HORIZONTAL Detector : Peak Project : Z73180-08 Mode : 7</p>	 <p>Site : 03CH10-HY Condition : FCC PART 15E_BAND4 3m HORN 9120D-HF VERTICAL Detector : Peak Project : Z73180-08 Mode : 7</p>

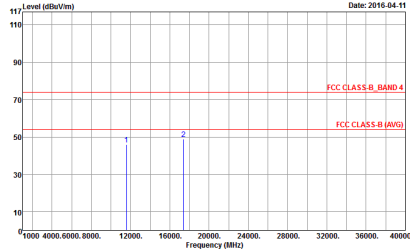
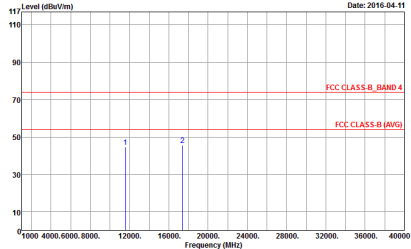

WIFI	Band 4 5725~5850MHz Harmonic @ 3m	
ANT	802.11n HT40 CH159 5795MHz	
1	Horizontal	Vertical
<p>Peak</p> <p>Avg.</p>	 <p style="font-size: small;">Date: 2016-04-11</p> <p style="font-size: x-small;">Site : 03CH10-HY Condition : FCC CLASS-B_BAND 4 3m HORN 9120D-HF HORIZONTAL Detector : Peak Project : Z73180-08 Mode : 8</p>	 <p style="font-size: small;">Date: 2016-04-11</p> <p style="font-size: x-small;">Site : 03CH10-HY Condition : FCC CLASS-B_BAND 4 3m HORN 9120D-HF VERTICAL Detector : Peak Project : Z73180-08 Mode : 8</p>



Emission below 1GHz
5GHz WIFI 802.11n HT40 (LF)

Table with 2 columns: Horizontal and Vertical. Each column contains a spectral plot of Level (dBuV/m) vs Frequency (MHz) from 30 to 1000 MHz. The plots show emission levels with peaks marked 1-6 and a red FCC CLASS-B limit line. Metadata includes Site: 03CH10-HY, Condition: FCC CLASS-B 3m BI-LO6 6111D-LF HORIZONTAL/VERTICAL, Detector: Peak, Project: 273180-08, Mode: 14.



Band 4 5725~5850MHz
WIFI 802.11n HT20 (Fundamental @ 3m)

Table with 2 main columns: Horizontal and Vertical. Each column contains a spectral plot showing Level (dBuV/m) vs Frequency (MHz) with a peak at approximately 5775 MHz. Includes metadata like Site, Condition, Detector, Project, and Mode.

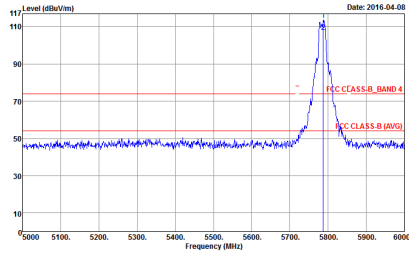
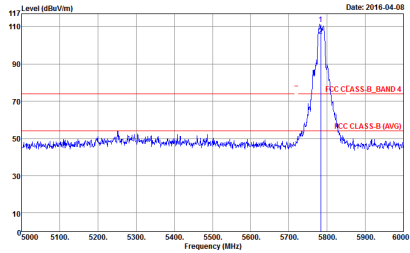

WIFI	Band 4 5725~5850MHz Fundamental @ 3m	
ANT	802.11n HT20 CH157 5785MHz	
1+2	Horizontal	Vertical
Peak / Avg.	 <p>Date: 2016-04-08</p> <p>Site : 03CH10-HY Condition : FCC CLASS-B_BAND 4 3m HORN 9120D-HF HORIZONTAL RBW:1000.000KHz VBW:3000.000KHz SWT:Auto Detector : Peak Project : 273180-08 Mode : IO</p>	 <p>Date: 2016-04-08</p> <p>Site : 03CH10-HY Condition : FCC CLASS-B_BAND 4 3m HORN 9120D-HF VERTICAL RBW:1000.000KHz VBW:3000.000KHz SWT:Auto Detector : Peak Project : 273180-08 Mode : IO</p>

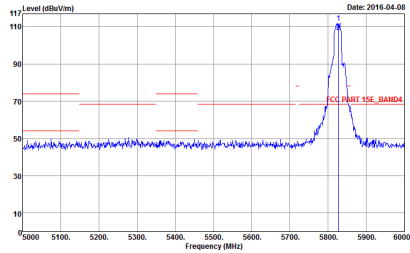
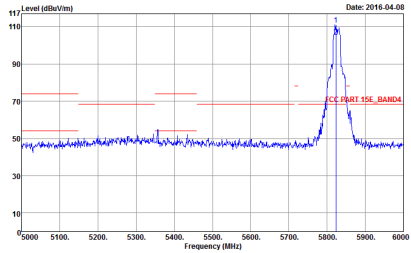

WIFI	Band 4 5725~5850MHz Fundamental @ 3m	
ANT	802.11n HT20 CH165 5825MHz	
1+2	Horizontal	Vertical
Peak / Avg.	 <p>Date: 2016-04-08</p> <p>Site : 03CH10-HY Condition : FCC PART 15E_BAND4 3m HORN 9120D-HF HORIZONTAL RBW:1000.000KHz VBW:3000.000KHz SWT:Auto Detector : Peak Project : 273180-08 Mode : II</p>	 <p>Date: 2016-04-08</p> <p>Site : 03CH10-HY Condition : FCC PART 15E_BAND4 3m HORN 9120D-HF VERTICAL RBW:1000.000KHz VBW:3000.000KHz SWT:Auto Detector : Peak Project : 273180-08 Mode : II</p>



Band 4 5725~5850MHz

WIFI 802.11n HT40 (Fundamental @ 3m)

WIFI	Band 4 5725~5850MHz Fundamental @ 3m	
ANT	802.11n HT40 CH151 5755MHz	
1+2	Horizontal	Vertical
Peak / Avg.	<p>Site : 03CH10-HY Condition : FCC PART 15E_BAND4 3m HORN 9120D-HF HORIZONTAL RBW:1000.000KHz VBW:3000.000KHz SWT:Auto Detector : Peak Project : 273180-08 Mode : 12</p>	<p>Site : 03CH10-HY Condition : FCC PART 15E_BAND4 3m HORN 9120D-HF VERTICAL RBW:1000.000KHz VBW:3000.000KHz SWT:Auto Detector : Peak Project : 273180-08 Mode : 12</p>

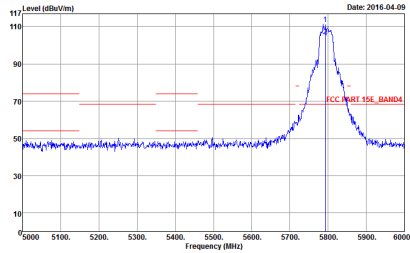
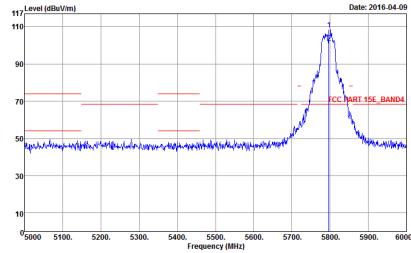

WIFI	Band 4 5725~5850MHz Fundamental @ 3m	
ANT	802.11n HT40 CH159 5795MHz	
1+2	Horizontal	Vertical
Peak / Avg.	 <p style="font-size: small;">Date: 2016-04-09</p> <p>Site : 03CH10-HY Condition : FCC PART 15E_BAND4 3m HORN 9120D-HF HORIZONTAL RBW:1000.000KHz VBW:3000.000KHz SWT:Auto Detector : Peak Project : 273180-08 Mode : 13</p>	 <p style="font-size: small;">Date: 2016-04-09</p> <p>Site : 03CH10-HY Condition : FCC PART 15E_BAND4 3m HORN 9120D-HF VERTICAL RBW:1000.000KHz VBW:3000.000KHz SWT:Auto Detector : Peak Project : 273180-08 Mode : 13</p>

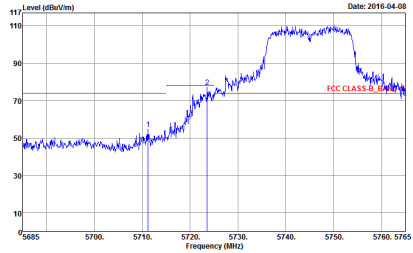
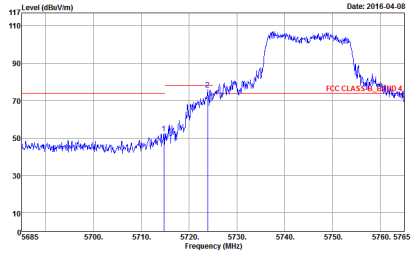
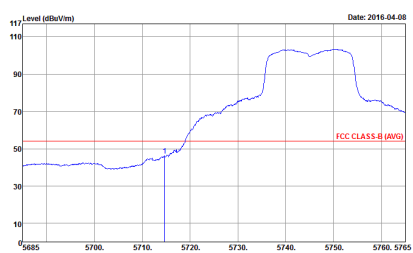
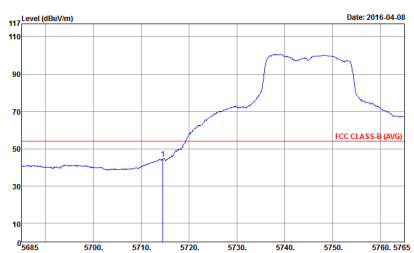

Band 4 5725~5850MHz
WIFI 802.11n HT20 (Band Edge @ 3m)

WIFI	Band 4 5725~5850MHz Band Edge @ 3m	
ANT	802.11n HT20 CH149 5745MHz	
1+2	Horizontal	Vertical
Peak	 <p>Site : 03CH10-HY Condition : FCC CLASS-B_BAND 4 3m HORN 9120D-HF HORIZONTAL Detector : Peak Project : 273180-08 Mode : 9</p>	 <p>Site : 03CH10-HY Condition : FCC CLASS-B_BAND 4 3m HORN 9120D-HF VERTICAL Detector : Peak Project : 273180-08 Mode : 9</p>
Avg.	 <p>Site : 03CH10-HY Condition : FCC CLASS-B (AVG) 3m HORN 9120D-HF HORIZONTAL Detector : Peak Project : 273180-08 Mode : 9</p>	 <p>Site : 03CH10-HY Condition : FCC CLASS-B (AVG) 3m HORN 9120D-HF VERTICAL Detector : Peak Project : 273180-08 Mode : 9</p>

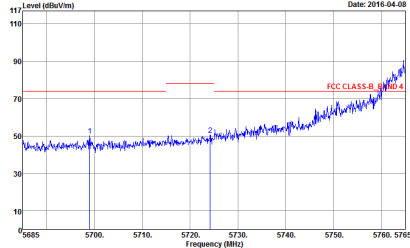
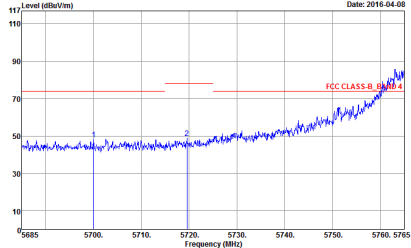
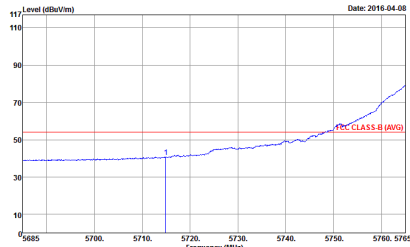
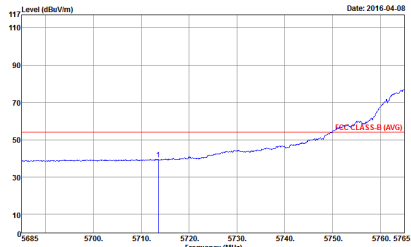

WIFI	Band 4 5725~5850MHz Band Edge @ 3m	
ANT	802.11n HT20 CH157 5785MHz - L	
1+2	Horizontal	Vertical
Peak	 <p>Date: 2016-04-08</p> <p>Site : 03CH10-HY Condition : FCC CLASS-B_BAND 4 3m HORN 9120D-HF HORIZONTAL Detector : Peak Project : 273180-08 Mode : 10</p>	 <p>Date: 2016-04-08</p> <p>Site : 03CH10-HY Condition : FCC CLASS-B_BAND 4 3m HORN 9120D-HF VERTICAL Detector : Peak Project : 273180-08 Mode : 10</p>
Avg.	 <p>Date: 2016-04-08</p> <p>Site : 03CH10-HY Condition : FCC CLASS-B (AVG) 3m HORN 9120D-HF HORIZONTAL Detector : Peak Project : 273180-08 Mode : 10</p>	 <p>Date: 2016-04-08</p> <p>Site : 03CH10-HY Condition : FCC CLASS-B (AVG) 3m HORN 9120D-HF VERTICAL Detector : Peak Project : 273180-08 Mode : 10</p>

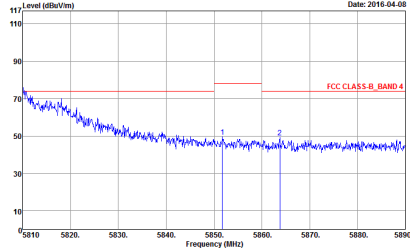
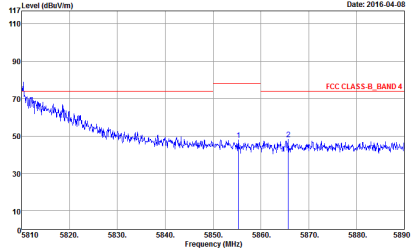
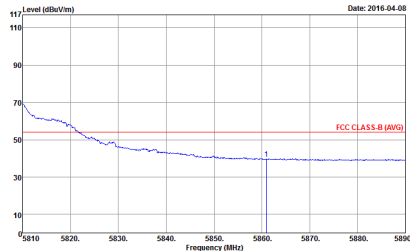
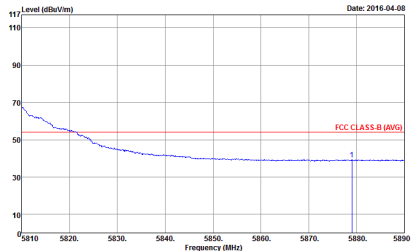

WIFI	Band 4 5725~5850MHz Band Edge @ 3m	
ANT	802.11n HT20 CH157 5785MHz - R	
1+2	Horizontal	Vertical
<p>Peak</p>	 <p>Date: 2016-04-08</p> <p>Site : 03CH10-HY Condition : FCC CLASS-B_BAND 4 3m HORN 9120D-HF HORIZONTAL RBW:1000.000KHz VBW:3000.000KHz SWT:Auto Detector : Peak Project : 273180-08 Mode : IO</p>	 <p>Date: 2016-04-08</p> <p>Site : 03CH10-HY Condition : FCC CLASS-B_BAND 4 3m HORN 9120D-HF VERTICAL RBW:1000.000KHz VBW:3000.000KHz SWT:Auto Detector : Peak Project : 273180-08 Mode : IO</p>
<p>Avg.</p>	 <p>Date: 2016-04-08</p> <p>Site : 03CH10-HY Condition : FCC CLASS-B (AVG) 3m HORN 9120D-HF HORIZONTAL RBW:1000.000KHz VBW:1000KHz SWT:Auto Detector : Peak Project : 273180-08 Mode : IO</p>	 <p>Date: 2016-04-08</p> <p>Site : 03CH10-HY Condition : FCC CLASS-B (AVG) 3m HORN 9120D-HF VERTICAL RBW:1000.000KHz VBW:1000KHz SWT:Auto Detector : Peak Project : 273180-08 Mode : IO</p>



WIFI	Band 4 5725~5850MHz Band Edge @ 3m	
ANT	802.11n HT20 CH165 5825MHz	
1+2	Horizontal	Vertical
Peak	<p style="font-size: small;">Date: 2016-04-08</p> <p style="font-size: x-small;">Site : 03CH10-HY Condition : FCC PART 15E_BAND4 3m HORN 9120D-HF HORIZONTAL RBW:1000.000KHz VBW:3000.000KHz SWT:Auto Detector : Peak Project : 273180-08 Mode : II</p>	<p style="font-size: small;">Date: 2016-04-08</p> <p style="font-size: x-small;">Site : 03CH10-HY Condition : FCC PART 15E_BAND4 3m HORN 9120D-HF VERTICAL RBW:1000.000KHz VBW:3000.000KHz SWT:Auto Detector : Peak Project : 273180-08 Mode : II</p>



Band 4 5725~5850MHz
WIFI 802.11n HT40 (Band Edge @ 3m)

Table with 2 columns: Horizontal and Vertical. Each column contains a graph of Level (dBuV/m) vs Frequency (MHz) and associated test parameters like Site, Condition, Detector, Project, and Mode.

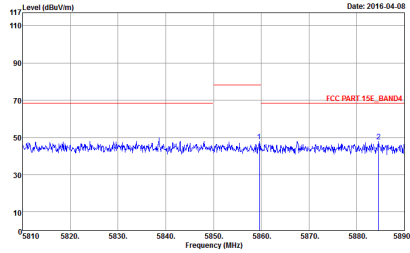
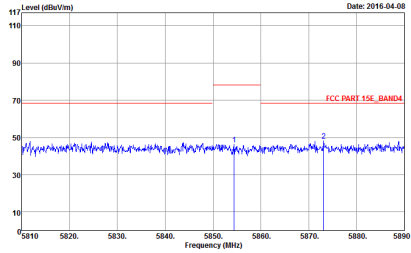

WIFI	Band 4 5725~5850MHz Band Edge @ 3m	
ANT	802.11n HT40 CH151 5755MHz - R	
1+2	Horizontal	Vertical
Peak	 <p>Site : 03CH10-HY Condition : FCC PART 15E_BAND4 3m HORN 9120D-HF HORIZONTAL Detector : Peak Project : 273180-08 Mode : 12</p>	 <p>Site : 03CH10-HY Condition : FCC PART 15E_BAND4 3m HORN 9120D-HF VERTICAL Detector : Peak Project : 273180-08 Mode : 12</p>

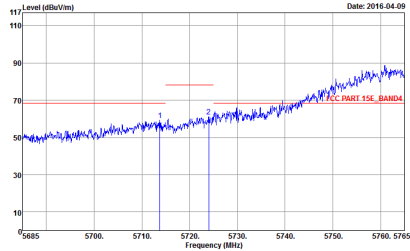
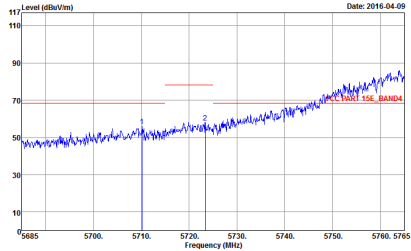

WIFI	Band 4 5725~5850MHz Band Edge @ 3m	
ANT	802.11n HT40 CH159 5795MHz - L	
1+2	Horizontal	Vertical
Peak	 <p>Date: 2016-04-09</p> <p>Site : 03CH10-HY Condition : FCC PART 15E_BAND4 3m HORN 9120D-HF HORIZONTAL RBW:1000.000KHz VBW:3000.000KHz SWT:Auto Detector : Peak Project : 273180-08 Mode : 13</p>	 <p>Date: 2016-04-09</p> <p>Site : 03CH10-HY Condition : FCC PART 15E_BAND4 3m HORN 9120D-HF VERTICAL RBW:1000.000KHz VBW:3000.000KHz SWT:Auto Detector : Peak Project : 273180-08 Mode : 13</p>

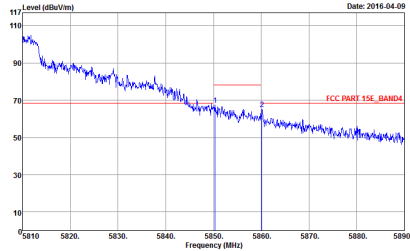
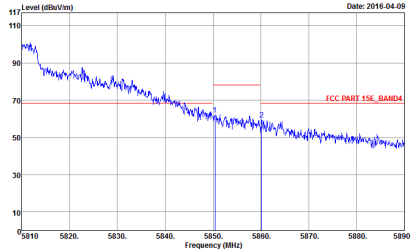

WIFI	Band 4 5725~5850MHz Band Edge @ 3m	
ANT	802.11n HT40 CH159 5795MHz - R	
1+2	Horizontal	Vertical
Peak	 <p>Date: 2016-04-09</p> <p>Site : 03CH10-HY Condition : FCC PART 15E_BAND4 3m HORN 9120D-HF HORIZONTAL RBW:1000.000KHz VBW:3000.000KHz SWT:Auto Detector : Peak Project : 273180-08 Mode : 13</p>	 <p>Date: 2016-04-09</p> <p>Site : 03CH10-HY Condition : FCC PART 15E_BAND4 3m HORN 9120D-HF VERTICAL RBW:1000.000KHz VBW:3000.000KHz SWT:Auto Detector : Peak Project : 273180-08 Mode : 13</p>



Band 4 5725~5850MHz
WIFI 802.11n HT20 (Harmonic @ 3m)

WIFI	Band 4 5725~5850MHz Harmonic @ 3m	
ANT	802.11n HT20 CH149 5745MHz	
1+2	Horizontal	Vertical
Peak Avg.	<p>Site : 03CH10-HY Condition : FCC CLASS-B_BAND 4 3m HORN 9120D-HF HORIZONTAL Detector : Peak Project : 273180-08 Mode : 9</p>	<p>Site : 03CH10-HY Condition : FCC CLASS-B_BAND 4 3m HORN 9120D-HF VERTICAL Detector : Peak Project : 273180-08 Mode : 9</p>

WIFI	Band 4 5725~5850MHz Harmonic @ 3m	
ANT	802.11n HT20 CH157 5785MHz	
1+2	Horizontal	Vertical
Peak Avg.	<p>Site : 03CH10-HY Condition : FCC CLASS-B_BAND 4 3m HORN 9120D-HF HORIZONTAL Detector : Peak Project : 273180-08 Mode : 10</p>	<p>Site : 03CH10-HY Condition : FCC CLASS-B_BAND 4 3m HORN 9120D-HF VERTICAL Detector : Peak Project : 273180-08 Mode : 10</p>



WIFI	Band 4 5725~5850MHz Harmonic @ 3m	
ANT	802.11n HT20 CH165 5825MHz	
1+2	Horizontal	Vertical
Peak Avg.	<p style="font-size: small;">Date: 2016-04-09</p> <p style="font-size: x-small;">Site : 03CH10-HY Condition : FCC PART 15E_BAND4 3m HORN 9120D-HF HORIZONTAL Detector : Peak Project : Z73180-08 Mode : II</p>	<p style="font-size: small;">Date: 2016-04-09</p> <p style="font-size: x-small;">Site : 03CH10-HY Condition : FCC PART 15E_BAND4 3m HORN 9120D-HF VERTICAL Detector : Peak Project : Z73180-08 Mode : II</p>



Band 4 5725~5850MHz

WIFI 802.11n HT40 (Harmonic @ 3m)

WIFI	Band 4 5725~5850MHz Harmonic @ 3m	
ANT	802.11n HT40 CH151 5755MHz	
1+2	Horizontal	Vertical
Peak Avg.	<p>Site : 03CH10-HY Condition : FCC PART 15E_BAND4 3m HORN 9120D-HF HORIZONTAL Detector : Peak Project : 273180-08 Mode : 12</p>	<p>Site : 03CH10-HY Condition : FCC PART 15E_BAND4 3m HORN 9120D-HF VERTICAL Detector : Peak Project : 273180-08 Mode : 12</p>

WIFI	Band 4 5725~5850MHz Harmonic @ 3m	
ANT	802.11n HT40 CH159 5795MHz	
1+2	Horizontal	Vertical
Peak Avg.	<p>Site : 03CH10-HY Condition : FCC PART 15E_BAND4 3m HORN 9120D-HF HORIZONTAL Detector : Peak Project : 273180-08 Mode : 13</p>	<p>Site : 03CH10-HY Condition : FCC PART 15E_BAND4 3m HORN 9120D-HF VERTICAL Detector : Peak Project : 273180-08 Mode : 13</p>

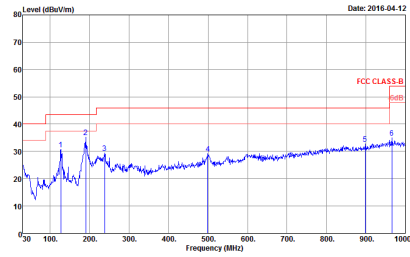
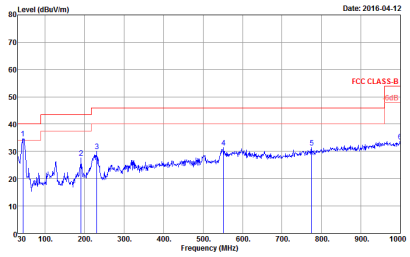

**Emission below 1GHz
5GHz WIFI 802.11n HT20 (LF)**

WIFI	5GHz 5725~5850MHz	
ANT	802.11n HT20 LF	
1+2	Horizontal	Vertical
QP / Peak	 <p> Site : 03CH10-HY Condition : FCC CLASS-B 3m BI-LO6 6111D-LF HORIZONTAL Detector : Peak Project : Z73180-08 Mode : 15 </p>	 <p> Site : 03CH10-HY Condition : FCC CLASS-B 3m BI-LO6 6111D-LF VERTICAL Detector : Peak Project : Z73180-08 Mode : 15 </p>