

FCC SAR Test Report

APPLICANT : BYD Precision Manufacture Co., Ltd.
EQUIPMENT : HP Slate 6 VoiceTab Plus
BRAND NAME : HP
MODEL NAME : HSTNH-B406M
FCC ID : ZW9HSTNH-B406M
STANDARD : FCC 47 CFR Part 2 (2.1093)
ANSI/IEEE C95.1-1992
IEEE 1528-2003

We, SPORTON INTERNATIONAL (SHENZHEN) INC., would like to declare that the tested sample has been evaluated in accordance with the procedures and had been in compliance with the applicable technical standards.

The test results in this report apply exclusively to the tested model / sample. Without written approval of SPORTON INTERNATIONAL (SHENZHEN) INC., the test report shall not be reproduced except in full.

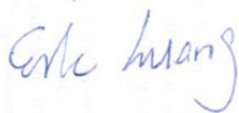

Reviewed by: Eric Huang / Deputy Manager



Approved by: Jones Tsai / Manager



SPORTON INTERNATIONAL (SHENZHEN) INC.

No. 101, Complex Building C, Guanlong Village, Xili Town, Nanshan District, Shenzhen, Guangdong, P.R.C.



Table of Contents

1. Statement of Compliance4

2. Administration Data5

3. Guidance Standard5

4. Equipment Under Test (EUT)6

 4.1 General Information6

 4.2 Maximum Tune-up Limit.....7

 4.3 General LTE SAR Test and Reporting Considerations14

5. RF Exposure Limits16

 5.1 Uncontrolled Environment.....16

 5.2 Controlled Environment.....16

6. Specific Absorption Rate (SAR).....17

 6.1 Introduction17

 6.2 SAR Definition.....17

7. System Description and Setup18

8. Measurement Procedures19

 8.1 Spatial Peak SAR Evaluation.....19

 8.2 Power Reference Measurement.....20

 8.3 Area Scan20

 8.4 Zoom Scan.....21

 8.5 Volume Scan Procedures.....21

 8.6 Power Drift Monitoring.....21

9. Test Equipment List22

10. System Verification23

 10.1 Tissue Verification23

 10.2 System Performance Check Results.....24

11. RF Exposure Positions25

 11.1 Ear and handset reference point25

 11.2 Definition of the cheek position.....26

 11.3 Definition of the tilt position.....27

 11.4 Body Worn Accessory28

 11.5 Extremity Exposure28

 11.6 Wireless Router.....28

12. Conducted RF Output Power (Unit: dBm).....29

13. Bluetooth Exclusions Applied51

14. Antenna Location52

15. SAR Test Results53

 15.1 Head SAR54

 15.2 Hotspot SAR58

 15.3 Body Worn Accessory SAR.....62

 15.4 Extremity SAR.....64

 15.5 Repeated SAR Measurement64

16. Simultaneous Transmission Analysis.....65

 16.1 Head Exposure Conditions66

 16.2 Hotspot Exposure Conditions.....70

 16.3 Body-Worn Accessory Exposure Conditions74

 16.4 SPLSR Evaluation and Analysis76

17. Uncertainty Assessment77

18. References.....79

Appendix A. Plots of System Performance Check

Appendix B. Plots of High SAR Measurement

Appendix C. DASy Calibration Certificate

Appendix D. Test Setup Photos



Revision History

REPORT NO.	VERSION	DESCRIPTION	ISSUED DATE
FA460901	Rev. 01	Initial issue of report	Sep. 03, 2014



1. Statement of Compliance

The maximum results of Specific Absorption Rate (SAR) found during testing for **BYD Precision Manufacture Co., Ltd., HP Slate 6 VoiceTab Plus, HSTNH-B406M** are as follows.

Equipment Class	Frequency Band	Operating Mode	Highest SAR Summary			
			Head 1g SAR (W/kg)	Body-worn 1g SAR (W/kg) (Gap 1cm)	Wireless Router 1g SAR (W/kg) (Gap 1cm)	Simultaneous Transmission SAR (W/kg)
PCE	GSM850	Voice/Data	0.40	0.59	0.59	1.57
	GSM1900	Voice/Data	0.31	0.66	0.80	
	WCDMA Band V	Voice/Data	0.25	0.37	0.37	
	WCDMA Band IV	Voice/Data	0.30	0.57	0.69	
	WCDMA Band II	Voice/Data	0.34	0.78	1.19	
	LTE Band 12	Data	0.26	0.43	0.43	
	LTE Band 17	Data	0.23	0.38	0.38	
	LTE Band 5	Data	0.20	0.29	0.29	
	LTE Band 26	Data	0.22	0.30	0.30	
	LTE Band 4	Data	0.32	0.77	0.81	
	LTE Band 2	Data	0.32	0.80	1.15	
	LTE Band 25	Data	0.24	0.76	1.15	
LTE Band 7	Data	0.06	0.58	1.44		
DTS	WLAN 2.4GHz Band	Data	1.30	0.57	0.57	1.57
DSS	Bluetooth	Data				1.44
Date of Testing:			08/03/2014 ~ 08/27/2014			

Equipment Class	Frequency Band	Operating Mode	Highest SAR Summary
			Extremity 10g SAR (W/kg) (Gap 0cm)
PCE	LTE Band 7	Data	0.24

This device is in compliance with Specific Absorption Rate (SAR) for general population/uncontrolled exposure limits (1.6 W/kg for 1g SAR, 4.0W/kg for 10g Extremity SAR) specified in FCC 47 CFR part 2 (2.1093) and ANSI/IEEE C95.1-1992, and had been tested in accordance with the measurement methods and procedures specified in IEEE 1528-2003.



2. Administration Data

Testing Laboratory	
Test Site	SPORTON INTERNATIONAL (SHENZHEN) INC.
Test Site Location	No. 101, Complex Building C, Guanlong Village, Xili Town, Nanshan District, Shenzhen, Guangdong, P.R.C. TEL: +86-755-8637-9589 FAX: +86-755-8637-9595

Applicant	
Company Name	BYD Precision Manufacture Co., Ltd.
Address	No.3001, Baohe Road, Baolong Industrial, Longgang, Shenzhen, P.R.China

Manufacturer	
Company Name	Hewlett-Packard Company
Address	1501 Page Mill Road Palo Alto, CA 94304 USA

3. Guidance Standard

The Specific Absorption Rate (SAR) testing specification, method, and procedure for this device is in accordance with the following standards:

- FCC 47 CFR Part 2 (2.1093)
- ANSI/IEEE C95.1-1992
- IEEE 1528-2003
- FCC KDB 865664 D01 SAR Measurement 100 MHz to 6 GHz v01r03
- FCC KDB 865664 D02 SAR Reporting v01r01
- FCC KDB 447498 D01 General RF Exposure Guidance v05r02
- FCC KDB 648474 D04 SAR Evaluation Considerations for Wireless Handsets v01r02
- FCC KDB 248227 D01 SAR meas for 802 11abg v01r02
- FCC KDB 941225 D01 SAR test for 3G devices v02
- FCC KDB 941225 D02 HSPA and 1x Advanced v02r02
- FCC KDB 941225 D03 SAR Test Reduction GSM GPRS EDGE v01
- FCC KDB 941225 D05 SAR for LTE Devices v02r03
- FCC KDB 941225 D06 Hotspot Mode SAR v01r01



4. Equipment Under Test (EUT)

4.1 General Information

Product Feature & Specification	
Equipment Name	HP Slate 6 VoiceTab Plus
Brand Name	HP
Model Name	HSTNH-B406M
FCC ID	ZW9HSTNH-B406M
IMEI Code	SIM 1: 004400152020002 SIM 2: 004400152020002
Wireless Technology and Frequency Range	GSM850: 824.2 MHz ~ 848.8 MHz GSM1900: 1850.2 MHz ~ 1909.8 MHz WCDMA Band V: 826.4 MHz ~ 846.6 MHz WCDMA Band IV: 1712.4 MHz ~ 1752.6 MHz WCDMA Band II: 1852.4 MHz ~ 1907.6 MHz LTE Band 12: 699.7 MHz ~ 715.3 MHz LTE Band 17: 706.5 MHz ~ 713.5 MHz LTE Band 26: 814.7 MHz ~ 848.3 MHz LTE Band 5: 824.7 MHz ~ 848.3 MHz LTE Band 4: 1710.7 MHz ~ 1754.3 MHz LTE Band 2: 1850.7 MHz ~ 1909.3 MHz LTE Band 25: 1850.7 MHz ~ 1914.3 MHz LTE Band 7: 2502.5 MHz ~ 2567.5 MHz WLAN 2.4GHz Band: 2412 MHz ~ 2462 MHz Bluetooth: 2402 MHz ~ 2480 MHz
Mode	<ul style="list-style-type: none"> • GSM/GPRS/EGPRS • RMC/AMR 12.2Kbps • HSDPA • HSUPA • LTE: QPSK, 16QAM • 802.11b/g/n HT20 • Bluetooth v3.0+EDR · Bluetooth v4.0 LE
HW Version	V2.0
SW Version	HP_Slate.6_V0.02.01_20140611.03_eng
GSM / (E)GPRS Transfer mode	Class B – EUT cannot support Packet Switched and Circuit Switched Network simultaneously but can automatically switch between Packet and Circuit Switched Network.
EUT Stage	Pre-Production
Remark: <ol style="list-style-type: none"> 1. 802.11n-HT40 is not supported in 2.4GHz WLAN. 2. This device 2.4GHz WLAN supports Hotspot operation. 3. This device supported VoIP in GPRS, EGPRS, WCDMA, LTE (e.g. 3rd party VoIP). 4. This device supports GRPS/EGPRS mode up to multi-slot class 33 and does not support DTM operation. 5. This device has 2 SIM slots and supports dual SIM dual Standby. The WWAN radio transmission will be enabled by either one SIM at a time (Single active). 6. For dual SIM card mobile, SIM1 supports GSM and WCDMA functions, and SIM2 only supports GSM function. 	



4.2 Maximum Tune-up Limit

Mode	Burst average power(dBm)	
	GSM 850	GSM 1900
GSM (GMSK, 1 Tx slot)	34	30.5
GPRS (GMSK, 1 Tx slot)	34	30.5
GPRS (GMSK, 2 Tx slots)	31.5	28.5
GPRS (GMSK, 3 Tx slots)	29.5	26
GPRS (GMSK, 4 Tx slots)	27.5	23.5
EDGE (8PSK, 1 Tx slot)	28	26
EDGE (8PSK, 2 Tx slots)	26	24.5
EDGE (8PSK, 3 Tx slots)	24	22.5
EDGE (8PSK, 4 Tx slots)	22	21

Mode	Average power(dBm)		
	WCDMA Band V	WCDMA Band II	WCDMA Band IV
AMR 12.2Kbps	24	25	23.5
RMC 12.2Kbps	24	25	23.5
HSDPA Subtest-1	23	24	23
HSDPA Subtest-2	23	24	23
HSDPA Subtest-3	22	24	22
HSDPA Subtest-4	22	23.5	22
HSUPA Subtest-1	23	24	22
HSUPA Subtest-2	22	23	22
HSUPA Subtest-3	22	23	22
HSUPA Subtest-4	22	23	22
HSUPA Subtest-5	23	24	23



LTE Band 12				
Average Power (dBm)				
Modulation	BW (MHz)	RB size	MPR	Power
QPSK	10	≤ 12	0	24.5
QPSK	10	> 12	0-1	23.5
16QAM	10	≤ 12	0-1	23.5
16QAM	10	> 12	0-2	22.5
QPSK	5	≤ 8	0	24.5
QPSK	5	> 8	0-1	23.5
16QAM	5	≤ 8	0-1	23.5
16QAM	5	> 8	0-2	22.5
QPSK	3	≤ 4	0	24.5
QPSK	3	> 4	0-1	23.5
16QAM	3	≤ 4	0-1	23.5
16QAM	3	> 4	0-2	22.5
QPSK	1.4	≤ 5	0	24.5
QPSK	1.4	> 5	0-1	23.5
16QAM	1.4	≤ 5	0-1	23.5
16QAM	1.4	> 5	0-2	22.5

LTE Band 17				
Average Power (dBm)				
Modulation	BW (MHz)	RB size	MPR	Power
QPSK	10	≤ 12	0	24
QPSK	10	> 12	0-1	23
16QAM	10	≤ 12	0-1	23
16QAM	10	> 12	0-2	22
QPSK	5	≤ 8	0	24
QPSK	5	> 8	0-1	23
16QAM	5	≤ 8	0-1	23
16QAM	5	> 8	0-2	22

LTE Band 7				
Average Power (dBm)				
Modulation	BW (MHz)	RB size	MPR	Target Power
QPSK	20	≤ 18	0	22
QPSK	20	> 18	0-1	21.5
16QAM	20	≤ 18	0-1	21
16QAM	20	> 18	0-2	21
QPSK	15	≤ 16	0	22
QPSK	15	> 16	0-1	21.5
16QAM	15	≤ 16	0-1	21
16QAM	15	> 16	0-2	21
QPSK	10	≤ 12	0	22
QPSK	10	> 12	0-1	21.5
16QAM	10	≤ 12	0-1	21
16QAM	10	> 12	0-2	21
QPSK	5	≤ 8	0	22
QPSK	5	> 8	0-1	21.5
16QAM	5	≤ 8	0-1	21
16QAM	5	> 8	0-2	21

LTE Band 5				
Average Power (dBm)				
Modulation	BW (MHz)	RB size	MPR	Power
QPSK	10	≤ 12	0	24
22.5QPSK	10	> 12	0-1	23
16QAM	10	≤ 12	0-1	23
16QAM	10	> 12	0-2	22
QPSK	5	≤ 8	0	24
QPSK	5	> 8	0-1	23
16QAM	5	≤ 8	0-1	23
16QAM	5	> 8	0-2	22
QPSK	3	≤ 4	0	24
QPSK	3	> 4	0-1	23
16QAM	3	≤ 4	0-1	23
16QAM	3	> 4	0-2	22
QPSK	1.4	≤ 5	0	24
QPSK	1.4	> 5	0-1	23
16QAM	1.4	≤ 5	0-1	23
16QAM	1.4	> 5	0-2	22

LTE Band 4				
Average Power (dBm)				
Modulation	BW (MHz)	RB size	MPR	Power
QPSK	20	≤ 18	0	24.5
QPSK	20	> 18	0-1	24
16QAM	20	≤ 18	0-1	24
16QAM	20	> 18	0-2	23
QPSK	15	≤ 16	0	24.5
QPSK	15	> 16	0-1	24
16QAM	15	≤ 16	0-1	24
16QAM	15	> 16	0-2	23
QPSK	10	≤ 12	0	24.5
QPSK	10	> 12	0-1	24
16QAM	10	≤ 12	0-1	24
16QAM	10	> 12	0-2	23
QPSK	5	≤ 8	0	24.5
QPSK	5	> 8	0-1	24
16QAM	5	≤ 8	0-1	24
16QAM	5	> 8	0-2	23
QPSK	3	≤ 4	0	24.5
QPSK	3	> 4	0-1	24
16QAM	3	≤ 4	0-1	24
16QAM	3	> 4	0-2	23
QPSK	1.4	≤ 5	0	24.5
QPSK	1.4	> 5	0-1	24
16QAM	1.4	≤ 5	0-1	24
16QAM	1.4	> 5	0-2	23

LTE Band 2				
Average Power (dBm)				
Modulation	BW (MHz)	RB size	MPR	Power
QPSK	20	≤ 18	0	25
QPSK	20	> 18	0-1	24
16QAM	20	≤ 18	0-1	24
16QAM	20	> 18	0-2	23
QPSK	15	≤ 16	0	25
QPSK	15	> 16	0-1	24
16QAM	15	≤ 16	0-1	24
16QAM	15	> 16	0-2	23
QPSK	10	≤ 12	0	25
QPSK	10	> 12	0-1	24
16QAM	10	≤ 12	0-1	24
16QAM	10	> 12	0-2	23
QPSK	5	≤ 8	0	25
QPSK	5	> 8	0-1	24
16QAM	5	≤ 8	0-1	24
16QAM	5	> 8	0-2	23
QPSK	3	≤ 4	0	25
QPSK	3	> 4	0-1	24
16QAM	3	≤ 4	0-1	24
16QAM	3	> 4	0-2	23
QPSK	1.4	≤ 5	0	25
QPSK	1.4	> 5	0-1	24
16QAM	1.4	≤ 5	0-1	24
16QAM	1.4	> 5	0-2	23

LTE Band 25				
Modulation	BW (MHz)	RB size	Target MPR	Target Power (dBm)
QPSK	20	≤ 18	0	25
QPSK	20	> 18	0-1	24.5
16QAM	20	≤ 18	0-1	24
16QAM	20	> 18	0-2	23.5
QPSK	15	≤ 16	0	25
QPSK	15	> 16	0-1	24.5
16QAM	15	≤ 16	0-1	24
16QAM	15	> 16	0-2	23.5
QPSK	10	≤ 12	0	25
QPSK	10	> 12	0-1	24.5
16QAM	10	≤ 12	0-1	24
16QAM	10	> 12	0-2	23.5
QPSK	5	≤ 8	0	25
QPSK	5	> 8	0-1	24.5
16QAM	5	≤ 8	0-1	24
16QAM	5	> 8	0-2	23.5
QPSK	3	≤ 4	0	25
QPSK	3	> 4	0-1	24.5
16QAM	3	≤ 4	0-1	24
16QAM	3	> 4	0-2	23.5
QPSK	1.4	≤ 5	0	25
QPSK	1.4	> 5	0-1	24.5
16QAM	1.4	≤ 5	0-1	24
16QAM	1.4	> 5	0-2	23.5

LTE Band 26				
Modulation	BW (MHz)	RB size	Target MPR	Target Power (dBm)
QPSK	15	≤ 16	0	24
QPSK	15	> 16	0-1	23
16QAM	15	≤ 16	0-1	23
16QAM	15	> 16	0-2	22
QPSK	10	≤ 12	0	24
QPSK	10	> 12	0-1	23
16QAM	10	≤ 12	0-1	23
16QAM	10	> 12	0-2	22
QPSK	5	≤ 8	0	24
QPSK	5	> 8	0-1	23
16QAM	5	≤ 8	0-1	23
16QAM	5	> 8	0-2	22
QPSK	3	≤ 4	0	24
QPSK	3	> 4	0-1	23
16QAM	3	≤ 4	0-1	23
16QAM	3	> 4	0-2	22
QPSK	1.4	≤ 5	0	24
QPSK	1.4	> 5	0-1	23
16QAM	1.4	≤ 5	0-1	23
16QAM	1.4	> 5	0-2	22

Mode			Average Power (dBm)
2.4GHz	802.11b	CH 1	13.5
		CH 6	14.5
		CH 11	14.5
	802.11g		14.5
	802.11n-HT20		13
Bluetooth v3.0+EDR			3
Bluetooth v4.0 LE			-0.5



4.3 General LTE SAR Test and Reporting Considerations

Summarized necessary items addressed in KDB 941225 D05 v02r03																																							
FCC ID	ZW9HSTNH-B406M																																						
Equipment Name	HP Slate 6 VoiceTab Plus																																						
Operating Frequency Range of each LTE transmission band	LTE Band 12: 699.7 MHz ~ 715.3 MHz LTE Band 17: 706.5 MHz ~ 713.5 MHz LTE Band 26: 814.7 MHz ~ 848.3 MHz LTE Band 5: 824.7 MHz ~ 848.3 MHz LTE Band 4: 1710.7 MHz ~ 1754.3 MHz LTE Band 2: 1850.7 MHz ~ 1909.3 MHz LTE Band 25: 1850.7 MHz ~ 1914.3 MHz LTE Band 7: 2502.5 MHz ~ 2567.5 MHz																																						
Channel Bandwidth	1.4MHz, 3MHz, 5MHz, 10MHz, 15MHz, 20MHz (LTE Band 2/4/25) 1.4MHz, 3MHz, 5MHz, 10MHz, 15MHz (LTE Band 26) 1.4MHz, 3MHz, 5MHz, 10MHz (LTE Band 5/12) 5MHz, 10MHz, 15MHz, 20MHz (LTE Band 7) 5MHz, 10MHz (LTE Band 17)																																						
uplink modulations used	QPSK, and 16QAM																																						
LTE Voice / Data requirements	Data only																																						
LTE MPR permanently built-in by design	<p align="center">Table 6.2.3-1: Maximum Power Reduction (MPR) for Power Class 3</p> <table border="1"> <thead> <tr> <th rowspan="2">Modulation</th> <th colspan="6">Channel bandwidth / Transmission bandwidth (RB)</th> <th rowspan="2">MPR (dB)</th> </tr> <tr> <th>1.4 MHz</th> <th>3.0 MHz</th> <th>5 MHz</th> <th>10 MHz</th> <th>15 MHz</th> <th>20 MHz</th> </tr> </thead> <tbody> <tr> <td>QPSK</td> <td>> 5</td> <td>> 4</td> <td>> 8</td> <td>> 12</td> <td>> 16</td> <td>> 18</td> <td>≤ 1</td> </tr> <tr> <td>16 QAM</td> <td>≤ 5</td> <td>≤ 4</td> <td>≤ 8</td> <td>≤ 12</td> <td>≤ 16</td> <td>≤ 18</td> <td>≤ 1</td> </tr> <tr> <td>16 QAM</td> <td>> 5</td> <td>> 4</td> <td>> 8</td> <td>> 12</td> <td>> 16</td> <td>> 18</td> <td>≤ 2</td> </tr> </tbody> </table>	Modulation	Channel bandwidth / Transmission bandwidth (RB)						MPR (dB)	1.4 MHz	3.0 MHz	5 MHz	10 MHz	15 MHz	20 MHz	QPSK	> 5	> 4	> 8	> 12	> 16	> 18	≤ 1	16 QAM	≤ 5	≤ 4	≤ 8	≤ 12	≤ 16	≤ 18	≤ 1	16 QAM	> 5	> 4	> 8	> 12	> 16	> 18	≤ 2
Modulation	Channel bandwidth / Transmission bandwidth (RB)						MPR (dB)																																
	1.4 MHz	3.0 MHz	5 MHz	10 MHz	15 MHz	20 MHz																																	
QPSK	> 5	> 4	> 8	> 12	> 16	> 18	≤ 1																																
16 QAM	≤ 5	≤ 4	≤ 8	≤ 12	≤ 16	≤ 18	≤ 1																																
16 QAM	> 5	> 4	> 8	> 12	> 16	> 18	≤ 2																																
LTE A-MPR	In the base station simulator configuration, Network Setting value is set to NS_01 to disable A-MPR during SAR testing and the LTE SAR tests was transmitting on all TTI frames (Maximum TTI)																																						
Spectrum plots for RB configuration	A properly configured base station simulator was used for the SAR and power measurement; therefore, spectrum plots for each RB allocation and offset configuration are not included in the SAR report.																																						

Transmission (H, M, L) channel numbers and frequencies in each LTE band												
LTE Band 12												
	Bandwidth 1.4 MHz		Bandwidth 3 MHz		Bandwidth 5 MHz		Bandwidth 10 MHz					
	Ch. #	Freq. (MHz)	Ch. #	Freq. (MHz)	Ch. #	Freq. (MHz)	Ch. #	Freq. (MHz)	Ch. #	Freq. (MHz)		
L	23017	699.7	23025	700.5	23035	701.5	23060	704				
M	23095	707.5	23095	707.5	23095	707.5	23095	707.5				
H	23173	715.3	23165	714.5	23155	713.5	23130	711				
LTE Band 17												
	Bandwidth 5 MHz				Bandwidth 10 MHz							
	Channel #		Freq.(MHz)		Channel #		Freq. (MHz)					
L	23755		706.5		23780		709					
M	23790		710		23790		710					
H	23825		713.5		23800		711					
LTE Band 5												
	Bandwidth 1.4 MHz		Bandwidth 3 MHz		Bandwidth 5 MHz		Bandwidth 10 MHz					
	Ch. #	Freq. (MHz)	Ch. #	Freq. (MHz)	Ch. #	Freq. (MHz)	Ch. #	Freq. (MHz)	Ch. #	Freq. (MHz)		
L	20407	824.7	20415	825.5	20425	826.5	20450	829				
M	20525	836.5	20525	836.5	20525	836.5	20525	836.5				
H	20643	848.3	20635	847.5	20625	846.5	20600	844				
LTE Band 26												
	Bandwidth 1.4 MHz		Bandwidth 3 MHz		Bandwidth 5 MHz		Bandwidth 10 MHz		Bandwidth 15 MHz			
	Ch. #	Freq. (MHz)	Ch. #	Freq. (MHz)	Ch. #	Freq. (MHz)	Ch. #	Freq. (MHz)	Ch. #	Freq. (MHz)	Ch. #	Freq. (MHz)
L	26697	814.7	26705	815.5	26715	816.5	26740	819	26765	821.5		
M	26865	831.5	26865	831.5	26865	831.5	26865	831.5	26865	831.5		
H	20733	848.3	27025	847.5	27015	846.5	26990	844	26965	841.5		
LTE Band 4												
	Bandwidth 1.4 MHz		Bandwidth 3 MHz		Bandwidth 5 MHz		Bandwidth 10 MHz		Bandwidth 15 MHz		Bandwidth 20 MHz	
	Ch. #	Freq. (MHz)	Ch. #	Freq. (MHz)	Ch. #	Freq. (MHz)	Ch. #	Freq. (MHz)	Ch. #	Freq. (MHz)	Ch. #	Freq. (MHz)
L	19957	1710.7	19965	1711.5	19975	1712.5	20000	1715	20025	1717.5	20050	1720
M	20175	1732.5	20175	1732.5	20175	1732.5	20175	1732.5	20175	1732.5	20175	1732.5
H	20393	1754.3	20385	1753.5	20375	1752.5	20350	1750	20325	1747.5	20300	1745
LTE Band 2												
	Bandwidth 1.4 MHz		Bandwidth 3 MHz		Bandwidth 5 MHz		Bandwidth 10 MHz		Bandwidth 15 MHz		Bandwidth 20 MHz	
	Ch. #	Freq. (MHz)	Ch. #	Freq. (MHz)	Ch. #	Freq. (MHz)	Ch. #	Freq. (MHz)	Ch. #	Freq. (MHz)	Ch. #	Freq. (MHz)
L	18607	1850.7	18615	1851.5	18625	1852.5	18650	1855	18675	1857.5	18700	1860
M	18900	1880	18900	1880	18900	1880	18900	1880	18900	1880	18900	1880
H	19193	1909.3	19185	1908.5	19175	1907.5	19150	1905	19125	1902.5	19100	1900
LTE Band 25												
	Bandwidth 1.4 MHz		Bandwidth 3 MHz		Bandwidth 5 MHz		Bandwidth 10 MHz		Bandwidth 15 MHz		Bandwidth 20 MHz	
	Ch. #	Freq. (MHz)	Ch. #	Freq. (MHz)	Ch. #	Freq. (MHz)	Ch. #	Freq. (MHz)	Ch. #	Freq. (MHz)	Ch. #	Freq. (MHz)
L	26047	1850.7	26055	1851.5	26065	1852.5	26090	1855	26115	1857.5	26140	1860
M	26340	1880	26340	1880	26340	1880	26340	1880	26340	1880	26340	1880
H	26683	1914.3	26675	1913.5	26665	1912.5	26640	1910	26615	1907.5	26590	1905
LTE Band 7												
	Bandwidth 5 MHz		Bandwidth 10 MHz		Bandwidth 15 MHz		Bandwidth 20 MHz					
	Ch. #	Freq. (MHz)	Ch. #	Freq. (MHz)	Ch. #	Freq. (MHz)	Ch. #	Freq. (MHz)	Ch. #	Freq. (MHz)		
L	20775	2502.5	20800	2505	20825	2507.5	20850	2510				
M	21100	2535	21100	2535	21100	2535	21100	2535				
H	21425	2567.5	21400	2565	21375	2562.5	21350	2560				

5. RF Exposure Limits

5.1 Uncontrolled Environment

Uncontrolled Environments are defined as locations where there is the exposure of individuals who have no knowledge or control of their exposure. The general population/uncontrolled exposure limits are applicable to situations in which the general public may be exposed or in which persons who are exposed as a consequence of their employment may not be made fully aware of the potential for exposure or cannot exercise control over their exposure. Members of the general public would come under this category when exposure is not employment-related; for example, in the case of a wireless transmitter that exposes persons in its vicinity.

5.2 Controlled Environment

Controlled Environments are defined as locations where there is exposure that may be incurred by persons who are aware of the potential for exposure, (i.e. as a result of employment or occupation). In general, occupational/controlled exposure limits are applicable to situations in which persons are exposed as a consequence of their employment, who have been made fully aware of the potential for exposure and can exercise control over their exposure. The exposure category is also applicable when the exposure is of a transient nature due to incidental passage through a location where the exposure levels may be higher than the general population/uncontrolled limits, but the exposed person is fully aware of the potential for exposure and can exercise control over his or her exposure by leaving the area or by some other appropriate means.

Limits for Occupational/Controlled Exposure (W/kg)

Whole-Body	Partial-Body	Hands, Wrists, Feet and Ankles
0.4	8.0	20.0

Limits for General Population/Uncontrolled Exposure (W/kg)

Whole-Body	Partial-Body	Hands, Wrists, Feet and Ankles
0.08	1.6	4.0

1. Whole-Body SAR is averaged over the entire body, partial-body SAR is averaged over any 1gram of tissue defined as a tissue volume in the shape of a cube. SAR for hands, wrists, feet and ankles is averaged over any 10 grams of tissue defined as a tissue volume in the shape of a cube.

6. Specific Absorption Rate (SAR)

6.1 Introduction

SAR is related to the rate at which energy is absorbed per unit mass in an object exposed to a radio field. The SAR distribution in a biological body is complicated and is usually carried out by experimental techniques or numerical modeling. The standard recommends limits for two tiers of groups, occupational/controlled and general population/uncontrolled, based on a person's awareness and ability to exercise control over his or her exposure. In general, occupational/controlled exposure limits are higher than the limits for general population/uncontrolled.

6.2 SAR Definition

The SAR definition is the time derivative (rate) of the incremental energy (dW) absorbed by (dissipated in) an incremental mass (dm) contained in a volume element (dv) of a given density (ρ). The equation description is as below:

$$SAR = \frac{d}{dt} \left(\frac{dW}{dm} \right) = \frac{d}{dt} \left(\frac{dW}{\rho dv} \right)$$

SAR is expressed in units of Watts per kilogram (W/kg)

$$SAR = \frac{\sigma |E|^2}{\rho}$$

Where: σ is the conductivity of the tissue, ρ is the mass density of the tissue and E is the RMS electrical field strength.

7. System Description and Setup

The DASY system used for performing compliance tests consists of the following items:

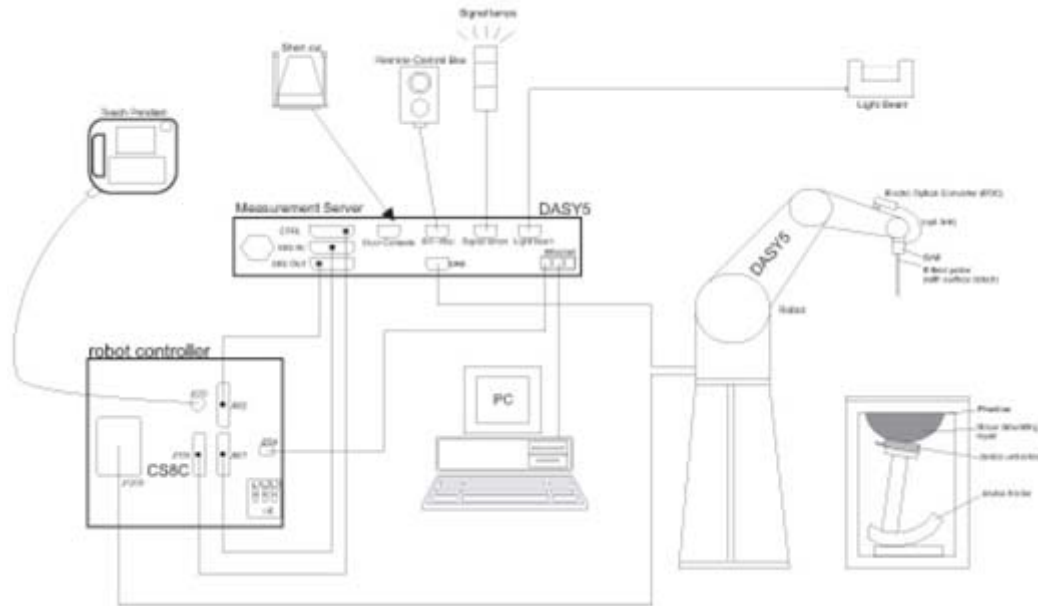

- A standard high precision 6-axis robot with controller, teach pendant and software. An arm extension for accommodating the data acquisition electronics (DAE).
- An isotropic Field probe optimized and calibrated for the targeted measurement.
- A data acquisition electronics (DAE) which performs the signal amplification, signal multiplexing, AD-conversion, offset measurements, mechanical surface detection, collision detection, etc. The unit is battery powered with standard or rechargeable batteries. The signal is optically transmitted to the EOC.
- The Electro-optical converter (EOC) performs the conversion from optical to electrical signals for the digital communication to the DAE. To use optical surface detection, a special version of the EOC is required. The EOC signal is transmitted to the measurement server.
- The function of the measurement server is to perform the time critical tasks such as signal filtering, control of the robot operation and fast movement interrupts.
- The Light Beam used is for probe alignment. This improves the (absolute) accuracy of the probe positioning.
- A computer running WinXP or Win7 and the DASY5 software.
- Remote control and teach pendant as well as additional circuitry for robot safety such as warning lamps, etc.
- The phantom, the device holder and other accessories according to the targeted measurement.

8. Measurement Procedures

The measurement procedures are as follows:

<Conducted power measurement>

- (a) For WWAN power measurement, use base station simulator to configure EUT WWAN transmission in conducted connection with RF cable, at maximum power in each supported wireless interface and frequency band.
- (b) Read the WWAN RF power level from the base station simulator.
- (c) For WLAN/BT power measurement, use engineering software to configure EUT WLAN/BT continuously transmission, at maximum RF power in each supported wireless interface and frequency band
- (d) Connect EUT RF port through RF cable to the power meter, and measure WLAN/BT output power

<SAR measurement>

- (a) Use base station simulator to configure EUT WWAN transmission in radiated connection, and engineering software to configure EUT WLAN/BT continuously transmission, at maximum RF power, in the highest power channel.
- (b) Place the EUT in the positions as Appendix D demonstrates.
- (c) Set scan area, grid size and other setting on the DASY software.
- (d) Measure SAR results for the highest power channel on each testing position.
- (e) Find out the largest SAR result on these testing positions of each band
- (f) Measure SAR results for other channels in worst SAR testing position if the reported SAR of highest power channel is larger than 0.8 W/kg

According to the test standard, the recommended procedure for assessing the peak spatial-average SAR value consists of the following steps:

- (a) Power reference measurement
- (b) Area scan
- (c) Zoom scan
- (d) Power drift measurement

8.1 Spatial Peak SAR Evaluation

The procedure for spatial peak SAR evaluation has been implemented according to the test standard. It can be conducted for 1g and 10g, as well as for user-specific masses. The DASY software includes all numerical procedures necessary to evaluate the spatial peak SAR value.

The base for the evaluation is a "cube" measurement. The measured volume must include the 1g and 10g cubes with the highest averaged SAR values. For that purpose, the center of the measured volume is aligned to the interpolated peak SAR value of a previously performed area scan.

The entire evaluation of the spatial peak values is performed within the post-processing engine (SEMCAD). The system always gives the maximum values for the 1g and 10g cubes. The algorithm to find the cube with highest averaged SAR is divided into the following stages:

- (a) Extraction of the measured data (grid and values) from the Zoom Scan
- (b) Calculation of the SAR value at every measurement point based on all stored data (A/D values and measurement parameters)
- (c) Generation of a high-resolution mesh within the measured volume
- (d) Interpolation of all measured values from the measurement grid to the high-resolution grid
- (e) Extrapolation of the entire 3-D field distribution to the phantom surface over the distance from sensor to surface
- (f) Calculation of the averaged SAR within masses of 1g and 10g

8.2 Power Reference Measurement

The Power Reference Measurement and Power Drift Measurements are for monitoring the power drift of the device under test in the batch process. The minimum distance of probe sensors to surface determines the closest measurement point to phantom surface. This distance cannot be smaller than the distance of sensor calibration points to probe tip as defined in the probe properties.

8.3 Area Scan

The area scan is used as a fast scan in two dimensions to find the area of high field values, before doing a fine measurement around the hot spot. The sophisticated interpolation routines implemented in DASY software can find the maximum found in the scanned area, within a range of the global maximum. The range (in dB0 is specified in the standards for compliance testing. For example, a 2 dB range is required in IEEE standard 1528 and IEC 62209 standards, whereby 3 dB is a requirement when compliance is assessed in accordance with the ARIB standard (Japan), if only one zoom scan follows the area scan, then only the absolute maximum will be taken as reference. For cases where multiple maximums are detected, the number of zoom scans has to be increased accordingly.

Area scan parameters extracted from FCC KDB 865664 D01v01r03 SAR measurement 100 MHz to 6 GHz.

	≤ 3 GHz	> 3 GHz
Maximum distance from closest measurement point (geometric center of probe sensors) to phantom surface	5 ± 1 mm	$\frac{1}{2} \cdot \delta \cdot \ln(2) \pm 0.5$ mm
Maximum probe angle from probe axis to phantom surface normal at the measurement location	30° ± 1°	20° ± 1°
Maximum area scan spatial resolution: $\Delta x_{Area}, \Delta y_{Area}$	≤ 2 GHz: ≤ 15 mm 2 – 3 GHz: ≤ 12 mm	3 – 4 GHz: ≤ 12 mm 4 – 6 GHz: ≤ 10 mm
	When the x or y dimension of the test device, in the measurement plane orientation, is smaller than the above, the measurement resolution must be ≤ the corresponding x or y dimension of the test device with at least one measurement point on the test device.	

8.4 Zoom Scan

Zoom scans are used assess the peak spatial SAR values within a cubic averaging volume containing 1 gram and 10 gram of simulated tissue. The zoom scan measures points (refer to table below) within a cube shoes base faces are centered on the maxima found in a preceding area scan job within the same procedure. When the measurement is done, the zoom scan evaluates the averaged SAR for 1 gram and 10 gram and displays these values next to the job's label.

Zoom scan parameters extracted from FCC KDB 865664 D01v01r03 SAR measurement 100 MHz to 6 GHz.

		≤ 3 GHz	> 3 GHz	
Maximum zoom scan spatial resolution: $\Delta x_{Zoom}, \Delta y_{Zoom}$		≤ 2 GHz: ≤ 8 mm 2 – 3 GHz: ≤ 5 mm*	3 – 4 GHz: ≤ 5 mm* 4 – 6 GHz: ≤ 4 mm*	
Maximum zoom scan spatial resolution, normal to phantom surface	uniform grid: $\Delta z_{Zoom}(n)$	≤ 5 mm	3 – 4 GHz: ≤ 4 mm 4 – 5 GHz: ≤ 3 mm 5 – 6 GHz: ≤ 2 mm	
	graded grid	$\Delta z_{Zoom}(1)$: between 1 st two points closest to phantom surface	≤ 4 mm	3 – 4 GHz: ≤ 3 mm 4 – 5 GHz: ≤ 2.5 mm 5 – 6 GHz: ≤ 2 mm
		$\Delta z_{Zoom}(n>1)$: between subsequent points	$\leq 1.5 \cdot \Delta z_{Zoom}(n-1)$	
Minimum zoom scan volume	x, y, z	≥ 30 mm	3 – 4 GHz: ≥ 28 mm 4 – 5 GHz: ≥ 25 mm 5 – 6 GHz: ≥ 22 mm	
Note: δ is the penetration depth of a plane-wave at normal incidence to the tissue medium; see draft standard IEEE P1528-2011 for details. * When zoom scan is required and the <i>reported</i> SAR from the <i>area scan based 1-g SAR estimation</i> procedures of KDB 447498 is ≤ 1.4 W/kg, ≤ 8 mm, ≤ 7 mm and ≤ 5 mm zoom scan resolution may be applied, respectively, for 2 GHz to 3 GHz, 3 GHz to 4 GHz and 4 GHz to 6 GHz.				

8.5 Volume Scan Procedures

The volume scan is used for assess overlapping SAR distributions for antennas transmitting in different frequency bands. It is equivalent to an oversized zoom scan used in standalone measurements. The measurement volume will be used to enclose all the simultaneous transmitting antennas. For antennas transmitting simultaneously in different frequency bands, the volume scan is measured separately in each frequency band. In order to sum correctly to compute the 1g aggregate SAR, the EUT remain in the same test position for all measurements and all volume scan use the same spatial resolution and grid spacing. When all volume scan were completed, the software, SEMCAD postprocessor can combine and subsequently superpose these measurement data to calculating the multiband SAR.

8.6 Power Drift Monitoring

All SAR testing is under the EUT install full charged battery and transmit maximum output power. In DASY measurement software, the power reference measurement and power drift measurement procedures are used for monitoring the power drift of EUT during SAR test. Both these procedures measure the field at a specified reference position before and after the SAR testing. The software will calculate the field difference in dB. If the power drifts more than 5%, the SAR will be retested.



9. Test Equipment List

Manufacturer	Name of Equipment	Type/Model	Serial Number	Calibration	
				Last Cal.	Due Date
SPEAG	750MHz System Validation Kit	D750V3	1099	Nov. 11, 2013	Nov. 10, 2014
SPEAG	835MHz System Validation Kit	D835V2	4d091	Nov. 18, 2011	Nov. 14, 2014
SPEAG	1750MHz System Validation Kit	D1750V2	1090	Mar. 27, 2013	Mar. 25, 2015
SPEAG	1900MHz System Validation Kit	D1900V2	5d118	Nov. 21, 2011	Nov. 14, 2014
SPEAG	2450MHz System Validation Kit	D2450V2	908	Mar. 26, 2013	Mar. 24, 2015
SPEAG	2600MHz System Validation Kit	D2600V2	1061	Mar. 26, 2013	Mar. 24, 2015
SPEAG	Data Acquisition Electronics	DAE3	569	Nov. 22, 2013	Nov. 21, 2014
SPEAG	Dosimetric E-Field Probe	EX3DV4	3819	Nov. 27, 2013	Nov. 26, 2014
SPEAG	SAM Twin Phantom	QD 000 P40 CD	TP-1670	NCR	NCR
SPEAG	SAM Twin Phantom	QD 000 P40 CD	TP-1671	NCR	NCR
SPEAG	Phone Positioner	N/A	N/A	NCR	NCR
Anritsu	Radio communication analyzer	MT8820C	6201074235	Nov. 05, 2013	Nov. 04, 2014
Agilent	Wireless Communication Test Set	E5515C	MY50267224	Oct. 10, 2013	Oct. 09, 2014
R&S	Network Analyzer	ZVB8	100106	Nov. 07, 2013	Nov. 06, 2014
SPEAG	Dielectric Assessment KIT	DAK-3.5	1032	NCR	NCR
Anritsu	Power Meter	ML2495A	1218010	Mar. 27, 2014	Mar. 26, 2015
Anritsu	Power Sensor	MA2411B	1207253	Mar. 27, 2014	Mar. 26, 2015
R&S	Spectrum Analyzer	FSP7	101230	Jun. 13, 2014	Jun. 12, 2015
Agilent	Dual Directional Coupler	778D	50422	Note 1	
Woken	Attenuator	WK0602-XX	N/A	Note 1	
PE	Attenuator	PE7005-10	N/A	Note 1	
PE	Attenuator	PE7005- 3	N/A	Note 1	
AR	Power Amplifier	5S1G4M2	0328767	Note 1	
Mini-Circuits	Power Amplifier	ZVE-3W	162601250	Note 1	
Mini-Circuits	Power Amplifier	ZHL-42W+	13440021344	Note 1	

General Note:

1. Prior to system verification and validation, the path loss from the signal generator to the system check source and the power meter, which includes the amplifier, cable, attenuator and directional coupler, was measured by the network analyzer. The reading of the power meter was offset by the path loss difference between the path to the power meter and the path to the system check source to monitor the actual power level fed to the system check source.
2. Referring to KDB 865664 D01v01r03, the dipole calibration interval can be extended to 3 years with justification. The dipoles are also not physically damaged, or repaired during the interval.
3. The justification data of dipole D835V2, SN: 4d091, D1750V2, SN: 1090, D1900V2, SN: 5d118, D2450V2, SN: 908 and D2600V2, SN: 1061 can be found in appendix C. The return loss is < -20dB, within 20% of prior calibration, the impedance is within 5 ohm of prior calibration.

10. System Verification

10.1 Tissue Verification

The following tissue formulations are provided for reference only as some of the parameters have not been thoroughly verified. The composition of ingredients may be modified accordingly to achieve the desired target tissue parameters required for routine SAR evaluation.

Frequency (MHz)	Water (%)	Sugar (%)	Cellulose (%)	Salt (%)	Preventol (%)	DGBE (%)	Conductivity (σ)	Permittivity (ϵ_r)
For Head								
750	41.1	57.0	0.2	1.4	0.2	0	0.89	41.9
835	40.3	57.9	0.2	1.4	0.2	0	0.90	41.5
1750	55.2	0	0	0.3	0	44.5	1.37	40.1
1800, 1900, 2000	55.2	0	0	0.3	0	44.5	1.40	40.0
2450	55.0	0	0	0	0	45.0	1.80	39.2
2600	54.8	0	0	0.1	0	45.1	1.96	39.0
For Body								
750	51.7	47.2	0	0.9	0.1	0	0.96	55.5
835	50.8	48.2	0	0.9	0.1	0	0.97	55.2
1750	70.2	0	0	0.4	0	29.4	1.49	53.4
1800, 1900, 2000	70.2	0	0	0.4	0	29.4	1.52	53.3
2450	68.6	0	0	0	0	31.4	1.95	52.7
2600	68.1	0	0	0.1	0	31.8	2.16	52.5

<Tissue Dielectric Parameter Check Results>

Frequency (MHz)	Tissue Type	Liquid Temp. (°C)	Conductivity (σ)	Permittivity (ϵ_r)	Conductivity Target (σ)	Permittivity Target (ϵ_r)	Delta (σ) (%)	Delta (ϵ_r) (%)	Limit (%)	Date
750	Head	22.6	0.888	40.879	0.89	41.90	-0.22	-2.44	±5	2014/8/6
835	Head	22.7	0.910	42.910	0.90	41.50	1.11	3.40	±5	2014/8/6
1750	Head	22.7	1.392	40.573	1.37	40.10	1.61	1.18	±5	2014/8/16
1750	Head	22.7	1.38	41.322	1.37	40.10	0.73	3.05	±5	2014/8/27
1900	Head	22.6	1.447	40.017	1.40	40.00	3.36	0.04	±5	2014/8/7
1900	Head	22.7	1.422	40.315	1.40	40.00	1.57	0.79	±5	2014/8/16
2450	Head	22.7	1.834	39.654	1.80	39.20	1.89	1.16	±5	2014/8/17
2600	Head	22.7	2.055	38.316	1.96	39.00	4.85	-1.75	±5	2014/8/15
750	Body	22.6	0.963	54.231	0.96	55.50	0.31	-2.29	±5	2014/8/5
835	Body	22.6	0.977	54.395	0.97	55.20	0.72	-1.46	±5	2014/8/5
1750	Body	22.7	1.528	52.031	1.49	53.40	2.55	-2.56	±5	2014/8/3
1750	Body	22.6	1.526	52.619	1.49	53.40	2.42	-1.46	±5	2014/8/27
1900	Body	22.7	1.581	54.208	1.52	53.30	4.01	1.70	±5	2014/8/3
1900	Body	22.6	1.545	53.535	1.52	53.30	1.64	0.44	±5	2014/8/13
2450	Body	22.6	2.013	51.474	1.95	52.70	3.23	-2.33	±5	2014/8/17
2600	Body	22.8	2.209	51.123	2.16	52.50	2.27	-2.62	±5	2014/8/4

10.2 System Performance Check Results

Comparing to the original SAR value provided by SPEAG, the verification data should be within its specification of 10 %. Below table shows the target SAR and measured SAR after normalized to 1W input power. The table below indicates the system performance check can meet the variation criterion and the plots can be referred to Appendix A of this report.

Date	Frequency (MHz)	Tissue Type	Input Power (mW)	Dipole S/N	Probe S/N	DAE S/N	Measured SAR (W/kg)	Targeted SAR (W/kg)	Normalized SAR (W/kg)	Deviation (%)
2014/8/6	750	Head	250	1099	3819	569	2.15	8.42	8.6	2.14
2014/8/6	835	Head	250	4d091	3819	569	2.30	9.40	9.2	-2.13
2014/8/16	1750	Head	250	1090	3819	569	9.13	36.90	36.52	-1.03
2014/8/27	1750	Head	250	1090	3819	910	8.94	36.90	35.76	-3.09
2014/8/7	1900	Head	250	5d118	3819	569	9.62	40.30	38.48	-4.52
2014/8/16	1900	Head	250	5d118	3819	569	9.46	40.30	37.84	-6.10
2014/8/17	2450	Head	250	908	3819	569	12.20	54.00	48.8	-9.63
2014/8/15	2600	Head	250	1061	3819	569	13.60	58.60	54.4	-7.17
2014/8/5	750	Body	250	1099	3819	569	2.25	8.56	9	5.14
2014/8/5	835	Body	250	4d091	3819	569	2.22	9.42	8.88	-5.73
2014/8/3	1750	Body	250	1090	3819	569	9.69	38.10	38.76	1.73
2014/8/27	1750	Body	250	1090	3819	910	9.57	38.10	38.28	0.47
2014/8/3	1900	Body	250	5d118	3819	569	10.70	41.80	42.8	2.39
2014/8/13	1900	Body	250	5d118	3819	569	10.40	41.80	41.6	-0.48
2014/8/17	2450	Body	250	908	3819	569	13.40	50.40	53.6	6.35
2014/8/4	2600	Body	250	1061	3819	569	13.30	55.60	53.2	-4.32

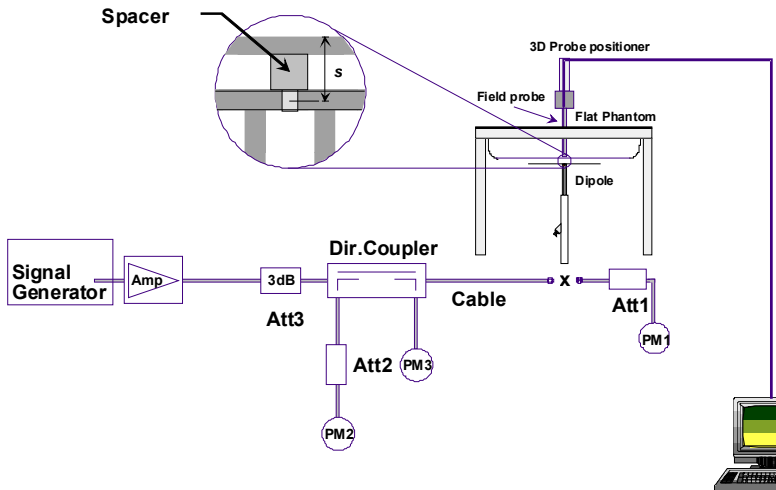

Fig 8.3.1 System Performance Check Setup



Fig 8.3.2 Setup Photo

11. RF Exposure Positions

11.1 Ear and handset reference point

Figure 9.1.1 shows the front, back, and side views of the SAM phantom. The center-of-mouth reference point is labeled “M,” the left ear reference point (ERP) is marked “LE,” and the right ERP is marked “RE.” Each ERP is 15 mm along the B-M (back-mouth) line behind the entrance-to-ear-canal (EEC) point, as shown in Figure 9.1.2 The Reference Plane is defined as passing through the two ear reference points and point M. The line N-F (neck-front), also called the reference pivoting line, is normal to the Reference Plane and perpendicular to both a line passing through RE and LE and the B-M line (see Figure 9.1.3). Both N-F and B-M lines should be marked on the exterior of the phantom shell to facilitate handset positioning. Posterior to the N-F line the ear shape is a flat surface with 6 mm thickness at each ERP, and forward of the N-F line the ear is truncated, as illustrated in Figure 9.1.2. The ear truncation is introduced to preclude the ear lobe from interfering with handset tilt, which could lead to unstable positioning at the cheek.

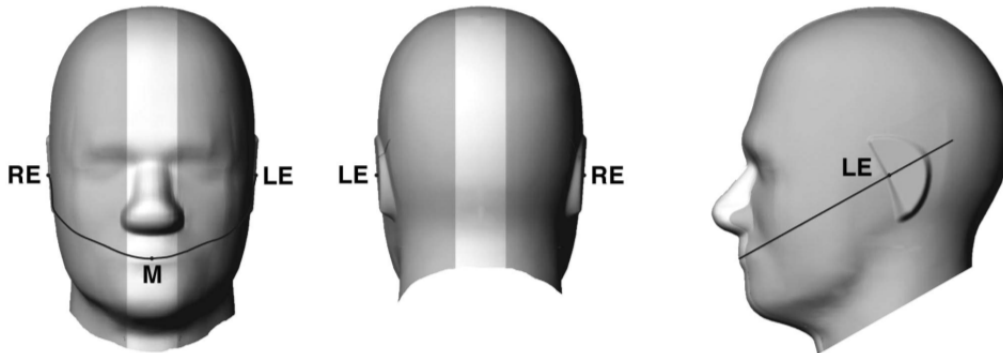

Fig 9.1.1 Front, back, and side views of SAM twin phantom

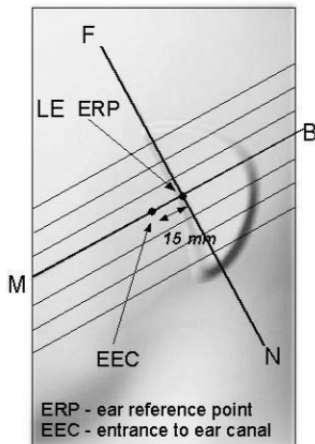

Fig 9.1.2 Close-up side view of phantom showing the ear region.

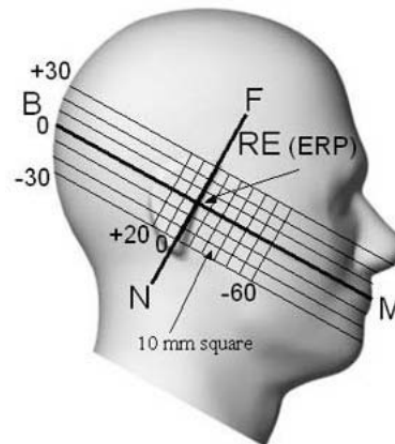

Fig 9.1.3 Side view of the phantom showing relevant markings and seven cross-sectional plane locations

11.2 Definition of the cheek position

1. Ready the handset for talk operation, if necessary. For example, for handsets with a cover piece (flip cover), open the cover. If the handset can transmit with the cover closed, both configurations must be tested.
2. Define two imaginary lines on the handset—the vertical centerline and the horizontal line. The vertical centerline passes through two points on the front side of the handset—the midpoint of the width w_t of the handset at the level of the acoustic output (point A in Figure 9.2.1 and Figure 9.2.2), and the midpoint of the width w_b of the bottom of the handset (point B). The horizontal line is perpendicular to the vertical centerline and passes through the center of the acoustic output (see Figure 9.2.1). The two lines intersect at point A. Note that for many handsets, point A coincides with the center of the acoustic output; however, the acoustic output may be located elsewhere on the horizontal line. Also note that the vertical centerline is not necessarily parallel to the front face of the handset (see Figure 9.2.2), especially for clamshell handsets, handsets with flip covers, and other irregularly-shaped handsets.
3. Position the handset close to the surface of the phantom such that point A is on the (virtual) extension of the line passing through points RE and LE on the phantom (see Figure 9.2.3), such that the plane defined by the vertical centerline and the horizontal line of the handset is approximately parallel to the sagittal plane of the phantom.
4. Translate the handset towards the phantom along the line passing through RE and LE until handset point A touches the pinna at the ERP.
5. While maintaining the handset in this plane, rotate it around the LE-RE line until the vertical centerline is in the plane normal to the plane containing B-M and N-F lines, i.e., the Reference Plane.
6. Rotate the handset around the vertical centerline until the handset (horizontal line) is parallel to the N-F line.
7. While maintaining the vertical centerline in the Reference Plane, keeping point A on the line passing through RE and LE, and maintaining the handset contact with the pinna, rotate the handset about the N-F line until any point on the handset is in contact with a phantom point below the pinna on the cheek. See Figure 9.2.3. The actual rotation angles should be documented in the test report.

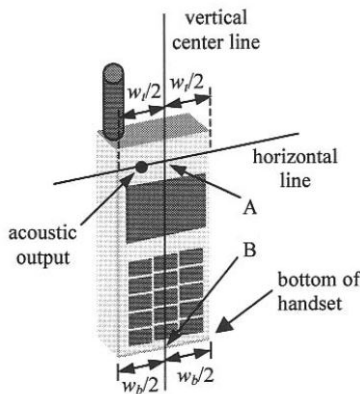

Fig 9.2.1 Handset vertical and horizontal reference lines—“fixed case”

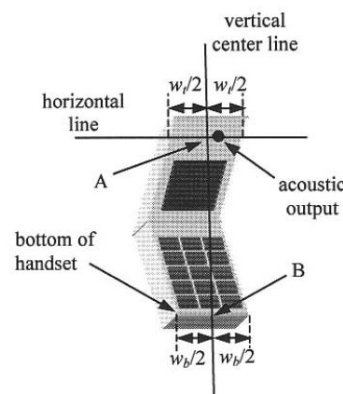

Fig 9.2.2 Handset vertical and horizontal reference lines—“clam-shell case”

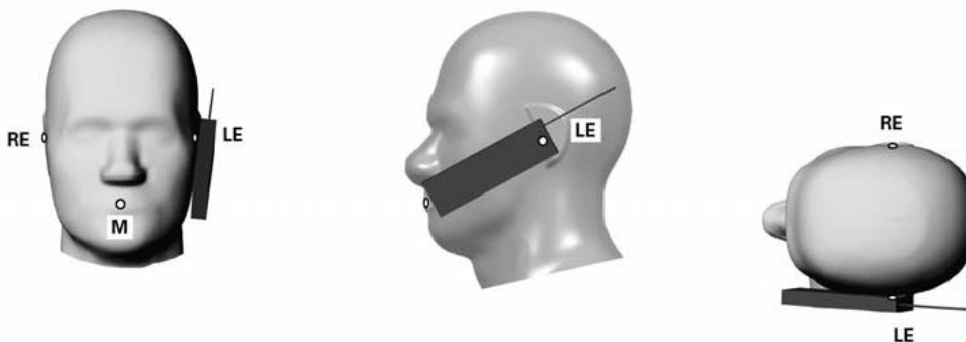

Fig 9.2.3 cheek or touch position. The reference points for the right ear (RE), left ear (LE), and mouth (M), which establish the Reference Plane for handset positioning, are indicated.

11.3 Definition of the tilt position

1. Ready the handset for talk operation, if necessary. For example, for handsets with a cover piece (flip cover), open the cover. If the handset can transmit with the cover closed, both configurations must be tested.
2. While maintaining the orientation of the handset, move the handset away from the pinna along the line passing through RE and LE far enough to allow a rotation of the handset away from the cheek by 15°.
3. Rotate the handset around the horizontal line by 15°.
4. While maintaining the orientation of the handset, move the handset towards the phantom on the line passing through RE and LE until any part of the handset touches the ear. The tilt position is obtained when the contact point is on the pinna. See Figure 9.3.1. If contact occurs at any location other than the pinna, e.g., the antenna at the back of the phantom head, the angle of the handset should be reduced. In this case, the tilt position is obtained if any point on the handset is in contact with the pinna and a second point

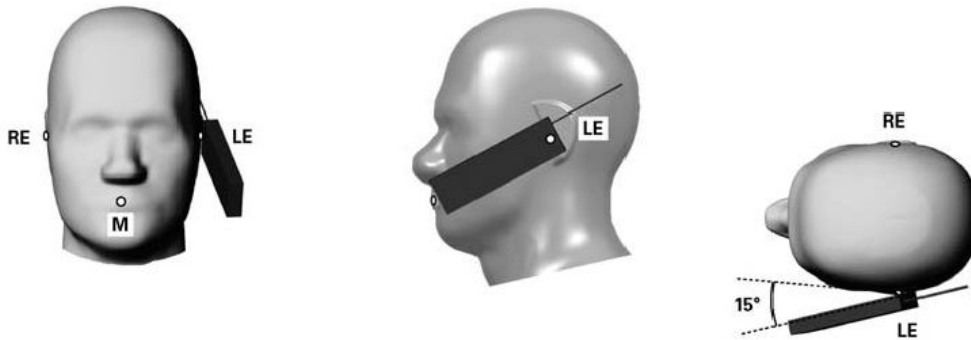

Fig 9.3.1 Tilt position. The reference points for the right ear (RE), left ear (LE), and mouth (M), which define the Reference Plane for handset positioning, are indicated.

11.4 Body Worn Accessory

Body-worn operating configurations are tested with the belt-clips and holsters attached to the device and positioned against a flat phantom in a normal use configuration (see Figure 9.4). Per KDB 648474 D04v01r02, body-worn accessory exposure is typically related to voice mode operations when handsets are carried in body-worn accessories. The body-worn accessory procedures in FCC KDB 447498 D01v05r02 should be used to test for body-worn accessory SAR compliance, without a headset connected to it. This enables the test results for such configuration to be compatible with that required for hotspot mode when the body-worn accessory test separation distance is greater than or equal to that required for hotspot mode, when applicable. When the reported SAR for body-worn accessory, measured without a headset connected to the handset is < 1.2 W/kg, the highest reported SAR configuration for that wireless mode and frequency band should be repeated for that body-worn accessory with a handset attached to the handset.

Accessories for body-worn operation configurations are divided into two categories: those that do not contain metallic components and those that do contain metallic components and those that do contain metallic components. When multiple accessories that do not contain metallic components are supplied with the device, the device is tested with only the accessory that dictates the closest spacing to the body. Then multiple accessories that contain metallic components are test with the device with each accessory. If multiple accessories share an identical metallic component (i.e. the same metallic belt-chip used with different holsters with no other metallic components) only the accessory that dictates the closest spacing to the body is tested.

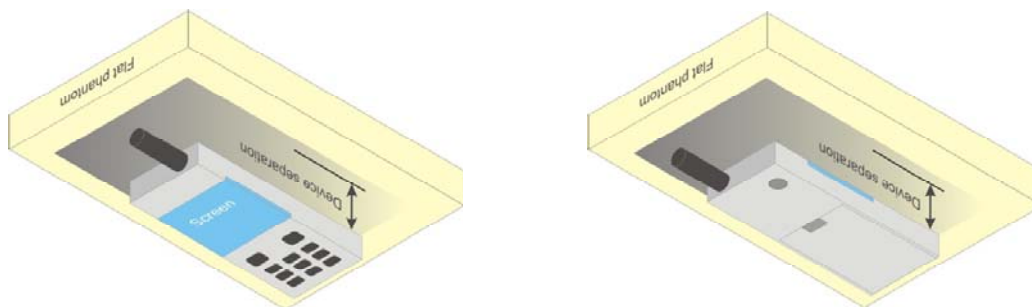

Fig 9.4 Body Worn Position

11.5 Extremity Exposure

For smart phones with a display diagonal dimension > 15.0 cm or an overall diagonal dimension > 16.0 cm that provide similar mobile web access and multimedia support found in mini-tablets or UMPC mini-tablets that support voice calls next to the ear, According to KDB648474D04v01r02, the following phablet procedures should be applied to evaluate SAR compliance for each applicable wireless modes and frequency band. Devices marketed as phablets, regardless of form factors and operating characteristics must be tested as a phablet to determine SAR compliance

1. The normally required head and body-worn accessory SAR test procedures for handsets, including hotspot mode, must be applied.
2. The UMPC mini-tablet procedures must also be applied to test the SAR of all surfaces and edges with an antenna located at ≤ 25 mm from that surface or edge, in direct contact with a flat phantom, for 10-g extremity SAR according to the body-equivalent tissue dielectric parameters in KDB 865664 to address interactive hand use exposure conditions.6 The UMPC mini-tablet 1-g SAR at 5 mm is not required. When hotspot mode applies, 10-g extremity SAR is required only for the surfaces and edges with hotspot mode 1-g reported SAR > 1.2 W/kg.

11.6 Wireless Router

Some battery-operated handsets have the capability to transmit and receive user through simultaneous transmission of WIFI simultaneously with a separate licensed transmitter. The FCC has provided guidance in FCC HDB Publication 941225 D06v01r01 where SAR test considerations for handsets (L x W ≥ 9 cm x 5 cm) are based on a composite test separation distance of 10mm from the front, back and edges of the device containing transmitting antennas within 2.5cm of their edges, determined from general mixed use conditions for this type of devices. Since the hotspot SAR results may overlap with the body-worn accessory SAR requirements, the more conservative configurations can be considered, thus excluding some body-worn accessory SAR tests.

When the user enables the personal wireless router functions for the handset, actual operations include simultaneous transmission of both the WIFI transmitter and another licensed transmitter. Both transmitters often do not transmit at the same transmitting frequency and thus cannot be evaluated for SAR under actual use conditions due to the limitations of the SAR assessment probes. Therefore, SAR must be evaluated for each frequency transmission and mode separately and spatially summed with the WIFI transmitter according to FCC KDB Publication 447498 D01v05r02 publication procedures. The “Portable Hotspot” feature on the handset was NOT activated during SAR assessments, to ensure the SAR measurements were evaluated for a single transmission frequency RF signal at a time.

12. Conducted RF Output Power (Unit: dBm)

<GSM Conducted Power>

General Note:

1. Per KDB 447498 D01v05r02, the maximum output power channel is used for SAR testing and for further SAR test reduction.
2. According to October 2013TCB Workshop, For GSM / GPRS / EGPRS, the number of time slots to test for SAR should correspond to the highest source-based time-averaged maximum output power configuration, Considering the possibility of e.g. 3rd party VoIP operation for head and body-worn SAR testing, the EUT was set in GPRS (2Tx slots) for GSM850/GSM1900 band due to its highest frame-average power.
3. For hotspot mode SAR testing, GPRS / EDGE should be evaluated, therefore the EUT was set in GPRS 2 Tx slots for GSM850/GSM1900 band due to its highest frame-average power.

SIM1 Card:

Band GSM850	Burst Average Power (dBm)			Tune-up Limit (dBm)	Frame-Average Power (dBm)			Tune-up Limit (dBm)
	TX Channel	128	189		251	128	189	
Frequency (MHz)	824.2	836.4	848.8		824.2	836.4	848.8	
GSM (GMSK, 1 Tx slot)	33.28	33.54	33.52	34	24.28	24.54	24.52	25
GPRS (GMSK, 1 Tx slot) – CS1	33.21	33.53	33.51	34	24.21	24.53	24.51	25
GPRS (GMSK, 2 Tx slots) – CS1	30.70	30.79	30.76	31.5	24.70	24.79	24.76	25.5
GPRS (GMSK, 3 Tx slots) – CS1	28.68	28.71	28.69	29.5	24.42	24.45	24.43	25.24
GPRS (GMSK, 4 Tx slots) – CS1	26.63	26.70	26.66	27.5	23.63	23.70	23.66	24.5
EDGE (8PSK, 1 Tx slot) – MCS5	27.33	27.16	27.18	28	18.33	18.16	18.18	19
EDGE (8PSK, 2 Tx slots) – MCS5	25.45	25.24	25.31	26	19.45	19.24	19.31	20
EDGE (8PSK, 3 Tx slots) – MCS5	23.56	23.34	23.37	24	19.30	19.08	19.11	19.74
EDGE (8PSK, 4 Tx slots) – MCS5	21.15	21.10	21.15	22	18.15	18.10	18.15	19
Band GSM1900	Burst Average Power (dBm)			Tune-up Limit (dBm)	Frame-Average Power (dBm)			Tune-up Limit (dBm)
TX Channel	512	661	810		512	661	810	
Frequency (MHz)	1850.2	1880	1909.8		1850.2	1880	1909.8	
GSM (GMSK, 1 Tx slot)	29.93	30.07	29.90	30.5	20.93	21.07	20.90	21.5
GPRS (GMSK, 1 Tx slot) – CS1	29.91	30.02	29.85	30.5	20.91	21.02	20.85	21.5
GPRS (GMSK, 2 Tx slots) – CS1	27.64	27.84	27.78	28.5	21.64	21.84	21.78	22.5
GPRS (GMSK, 3 Tx slots) – CS1	25.38	25.53	25.47	26	21.12	21.27	21.21	21.74
GPRS (GMSK, 4 Tx slots) – CS1	22.90	23.04	23.10	23.5	19.90	20.04	20.10	20.5
EDGE (8PSK, 1 Tx slot) – MCS5	25.94	25.94	25.93	26	16.94	16.94	16.93	17
EDGE (8PSK, 2 Tx slots) – MCS5	23.94	23.91	24.00	24.5	17.94	17.91	18.00	18.5
EDGE (8PSK, 3 Tx slots) – MCS5	22.00	21.96	21.99	22.5	17.74	17.70	17.73	18.24
EDGE (8PSK, 4 Tx slots) – MCS5	20.43	20.38	20.44	21	17.43	17.38	17.44	18

Remark: The frame-averaged power is linearly scaled the maximum burst averaged power over 8 time slots.

The calculated method are shown as below:

- Frame-averaged power = Maximum burst averaged power (1 Tx Slot) - 9 dB
- Frame-averaged power = Maximum burst averaged power (2 Tx Slots) - 6 dB
- Frame-averaged power = Maximum burst averaged power (3 Tx Slots) - 4.26 dB
- Frame-averaged power = Maximum burst averaged power (4 Tx Slots) - 3 dB



SIM2 Card:

Band GSM850	Burst Average Power (dBm)			Tune-up Limit (dBm)	Frame-Average Power (dBm)			Tune-up Limit (dBm)
	TX Channel	128	189		251	128	189	
Frequency (MHz)	824.2	836.4	848.8		824.2	836.4	848.8	
GSM (GMSK, 1 Tx slot)	33.25	33.49	33.45	34	24.25	24.49	24.45	25
GPRS (GMSK, 1 Tx slot) – CS1	33.20	33.47	33.42	34	24.20	24.47	24.42	25
GPRS (GMSK, 2 Tx slots) – CS1	30.68	30.75	30.72	31.5	24.68	24.75	24.72	25.5
GPRS (GMSK, 3 Tx slots) – CS1	28.65	28.70	28.68	29.5	24.39	24.44	24.42	25.24
GPRS (GMSK, 4 Tx slots) – CS1	26.55	26.69	26.64	27.5	23.55	23.69	23.64	24.5
EDGE (8PSK, 1 Tx slot) – MCS5	27.30	27.12	27.10	28	18.30	18.12	18.10	19
EDGE (8PSK, 2 Tx slots) – MCS5	25.43	25.22	25.18	26	19.43	19.22	19.18	20
EDGE (8PSK, 3 Tx slots) – MCS5	23.55	23.30	23.22	24	19.29	19.04	18.96	19.74
EDGE (8PSK, 4 Tx slots) – MCS5	20.99	21.02	21.00	22	17.99	18.02	18.00	19
Band GSM1900	Burst Average Power (dBm)			Tune-up Limit (dBm)	Frame-Average Power (dBm)			Tune-up Limit (dBm)
TX Channel	512	661	810		512	661	810	
Frequency (MHz)	1850.2	1880	1909.8		1850.2	1880	1909.8	
GSM (GMSK, 1 Tx slot)	29.91	30.05	29.88	30.5	20.91	21.05	20.88	21.5
GPRS (GMSK, 1 Tx slot) – CS1	29.90	30.00	29.82	30.5	20.90	21.00	20.82	21.5
GPRS (GMSK, 2 Tx slots) – CS1	27.60	27.83	27.76	28.5	21.60	21.83	21.76	22.5
GPRS (GMSK, 3 Tx slots) – CS1	25.35	25.50	25.45	26	21.09	21.24	21.19	21.74
GPRS (GMSK, 4 Tx slots) – CS1	22.85	23.01	23.08	23.5	19.85	20.01	20.08	20.5
EDGE (8PSK, 1 Tx slot) – MCS5	25.92	25.92	25.90	26	16.92	16.92	16.90	17
EDGE (8PSK, 2 Tx slots) – MCS5	23.88	23.91	23.98	24.5	17.88	17.91	17.98	18.5
EDGE (8PSK, 3 Tx slots) – MCS5	21.98	21.90	21.97	22.5	17.72	17.64	17.71	18.24
EDGE (8PSK, 4 Tx slots) – MCS5	20.40	20.33	20.40	21	17.40	17.33	17.40	18

Remark: The frame-averaged power is linearly scaled the maximum burst averaged power over 8 time slots.

The calculated method are shown as below:

- Frame-averaged power = Maximum burst averaged power (1 Tx Slot) - 9 dB
- Frame-averaged power = Maximum burst averaged power (2 Tx Slots) - 6 dB
- Frame-averaged power = Maximum burst averaged power (3 Tx Slots) - 4.26 dB
- Frame-averaged power = Maximum burst averaged power (4 Tx Slots) - 3 dB

<WCDMA Conducted Power>

1. The following tests were conducted according to the test requirements outlines in 3GPP TS 34.121 specification.
2. The procedures in KDB 941225 D01 are applied for 3GPP Rel. 6 HSPA to configure the device in the required sub-test mode(s) to determine SAR test exclusion.

A summary of these settings are illustrated below:

HSDPA Setup Configuration:

- a. The EUT was connected to Base Station Agilent E5515C referred to the Setup Configuration.
- b. The RF path losses were compensated into the measurements.
- c. A call was established between EUT and Base Station with following setting:
 - i. Set Gain Factors (β_c and β_d) and parameters were set according to each
 - ii. Specific sub-test in the following table, C10.1.4, quoted from the TS 34.121
 - iii. Set RMC 12.2Kbps + HSDPA mode.
 - iv. Set Cell Power = -86 dBm
 - v. Set HS-DSCH Configuration Type to FRC (H-set 1, QPSK)
 - vi. Select HSDPA Uplink Parameters
 - vii. Set Delta ACK, Delta NACK and Delta CQI = 8
 - viii. Set Ack-Nack Repetition Factor to 3
 - ix. Set CQI Feedback Cycle (k) to 4 ms
 - x. Set CQI Repetition Factor to 2
 - xi. Power Ctrl Mode = All Up bits
- d. The transmitted maximum output power was recorded.

Table C.10.1.4: β values for transmitter characteristics tests with HS-DPCCH

Sub-test	β_c	β_d	β_d (SF)	β_c/β_d	β_{HS} (Note 1, Note 2)	CM (dB) (Note 3)	MPR (dB) (Note 3)
1	2/15	15/15	64	2/15	4/15	0.0	0.0
2	12/15 (Note 4)	15/15 (Note 4)	64	12/15 (Note 4)	24/15	1.0	0.0
3	15/15	8/15	64	15/8	30/15	1.5	0.5
4	15/15	4/15	64	15/4	30/15	1.5	0.5

Note 1: $\Delta_{ACK}, \Delta_{NACK}$ and $\Delta_{CQI} = 30/15$ with $\beta_{HS} = 30/15 * \beta_c$.

Note 2: For the HS-DPCCH power mask requirement test in clause 5.2C, 5.7A, and the Error Vector Magnitude (EVM) with HS-DPCCH test in clause 5.13.1A, and HSDPA EVM with phase discontinuity in clause 5.13.1AA, Δ_{ACK} and $\Delta_{NACK} = 30/15$ with $\beta_{HS} = 30/15 * \beta_c$, and $\Delta_{CQI} = 24/15$ with $\beta_{HS} = 24/15 * \beta_c$.

Note 3: CM = 1 for $\beta_c/\beta_d = 12/15, \beta_{HS}/\beta_c = 24/15$. For all other combinations of DPDCCH, DPCCH and HS-DPCCH the MPR is based on the relative CM difference. This is applicable for only UEs that support HSDPA in release 6 and later releases.

Note 4: For subtest 2 the β_c/β_d ratio of 12/15 for the TFC during the measurement period (TF1, TF0) is achieved by setting the signalled gain factors for the reference TFC (TF1, TF1) to $\beta_c = 11/15$ and $\beta_d = 15/15$.

Setup Configuration

HSUPA Setup Configuration:

- a. The EUT was connected to Base Station Agilent E5515C referred to the Setup Configuration.
- b. The RF path losses were compensated into the measurements.
- c. A call was established between EUT and Base Station with following setting * :
 - i. Call Configs = 5.2B, 5.9B, 5.10B, and 5.13.2B with QPSK
 - ii. Set the Gain Factors (β_c and β_d) and parameters (AG Index) were set according to each specific sub-test in the following table, C11.1.3, quoted from the TS 34.121
 - iii. Set Cell Power = -86 dBm
 - iv. Set Channel Type = 12.2k + HSPA
 - v. Set UE Target Power
 - vi. Power Ctrl Mode= Alternating bits
 - vii. Set and observe the E-TFCl
 - viii. Confirm that E-TFCl is equal to the target E-TFCl of 75 for sub-test 1, and other subtest's E-TFCl
- d. The transmitted maximum output power was recorded.

Table C.11.1.3: β values for transmitter characteristics tests with HS-DPCCH and E-DCH

Sub-test	β_c	β_d	β_d (SF)	β_c/β_d	β_{HS} (Note 1)	β_{ec}	β_{ed} (Note 5) (Note 6)	β_{ed} (SF)	β_{ed} (Codes)	CM (dB) (Note 2)	MPR (dB) (Note 2)	AG Index (Note 6)	E-TFCl
1	11/15 (Note 3)	15/15 (Note 3)	64	11/15 (Note 3)	22/15	209/25	1309/225	4	1	1.0	0.0	20	75
2	6/15	15/15	64	6/15	12/15	12/15	94/75	4	1	3.0	2.0	12	67
3	15/15	9/15	64	15/9	30/15	30/15	$\beta_{ed1}: 47/15$ $\beta_{ed2}: 47/15$	4 4	2	2.0	1.0	15	92
4	2/15	15/15	64	2/15	4/15	2/15	56/75	4	1	3.0	2.0	17	71
5	15/15 (Note 4)	15/15 (Note 4)	64	15/15 (Note 4)	30/15	24/15	134/15	4	1	1.0	0.0	21	81

Note 1: $\Delta_{ACK}, \Delta_{NACK}$ and $\Delta_{CQI} = 30/15$ with $\beta_{hs} = 30/15 * \beta_c$.

Note 2: CM = 1 for $\beta_c/\beta_d = 12/15$, $\beta_{hs}/\beta_c = 24/15$. For all other combinations of DPDCH, DPCCH, HS- DPCCH, E-DPDCH and E-DPCCH the MPR is based on the relative CM difference.

Note 3: For subtest 1 the β_c/β_d ratio of 11/15 for the TFC during the measurement period (TF1, TF0) is achieved by setting the signalled gain factors for the reference TFC (TF1, TF1) to $\beta_c = 10/15$ and $\beta_d = 15/15$.

Note 4: For subtest 5 the β_c/β_d ratio of 15/15 for the TFC during the measurement period (TF1, TF0) is achieved by setting the signalled gain factors for the reference TFC (TF1, TF1) to $\beta_c = 14/15$ and $\beta_d = 15/15$.

Note 5: In case of testing by UE using E-DPDCH Physical Layer category 1, Sub-test 3 is omitted according to TS25.306 Table 5.1g.

Note 6: β_{ed} can not be set directly, it is set by Absolute Grant Value.

Setup Configuration



<WCDMA Conducted Power>

General Note:

- SAR testing in AMR configuration is not required when the maximum average output of each RF channel for AMR 12.2Kbps is less than 0.25dB higher than that measured in RMC 12.2Kbps
- Per KDB 941225 D02v02r02, RMC 12.2kbps setting is used to evaluate SAR. If HSDPA/HSUPA output power is < 0.25dB higher than RMC, or reported SAR with RMC 12.2kbps setting is $\leq 1.2W/kg$, HSDPA/HSUPA SAR evaluation can be excluded..

SIM1 Card:

Band			WCDMA Band V				WCDMA Band II			
Tx Channel			4132	4182	4233	Tune-up Limit (dBm)	9262	9400	9538	Tune-up Limit (dBm)
Rx Channel			4357	4407	4458		9662	9800	9938	
Frequency (MHz)			826.4	836.4	846.6		1852.4	1880	1907.6	
MPR (dB)	3GPP Rel 99	AMR 12.2Kbps	23.12	23.10	23.05	24	24.19	24.40	24.51	25
	3GPP Rel 99	RMC 12.2Kbps	23.13	23.11	23.07	24	24.21	24.41	24.54	25
0	3GPP Rel 6	HSDPA Subtest-1	22.16	22.28	22.23	23	23.17	23.34	23.54	24
0	3GPP Rel 6	HSDPA Subtest-2	22.18	22.26	22.25	23	23.22	23.44	23.52	24
0.5	3GPP Rel 6	HSDPA Subtest-3	21.67	21.75	21.75	22	22.68	22.91	23.01	24
0.5	3GPP Rel 6	HSDPA Subtest-4	21.67	21.38	21.75	22	22.76	22.90	23.00	23.5
0	3GPP Rel 6	HSUPA Subtest-1	22.14	21.59	21.75	23	23.27	23.46	23.23	24
2	3GPP Rel 6	HSUPA Subtest-2	20.88	21.07	21.24	22	21.96	21.96	22.09	23
1	3GPP Rel 6	HSUPA Subtest-3	20.53	21.24	20.81	22	21.81	22.28	22.00	23
2	3GPP Rel 6	HSUPA Subtest-4	21.11	21.32	21.36	22	21.68	22.24	22.09	23
0	3GPP Rel 6	HSUPA Subtest-5	22.20	22.20	22.10	23	23.40	23.50	23.50	24

Band			WCDMA Band IV			
Tx Channel			1312	1413	1513	Tune-up Limit (dBm)
Rx Channel			1537	1638	1738	
Frequency (MHz)			1712.4	1732.6	1752.6	
MPR (dB)	3GPP Rel 99	AMR 12.2Kbps	23.14	23.17	23.26	23.5
	3GPP Rel 99	RMC 12.2Kbps	23.15	23.19	23.27	23.5
0	3GPP Rel 6	HSDPA Subtest-1	22.23	22.38	22.51	23
0	3GPP Rel 6	HSDPA Subtest-2	22.27	22.38	22.46	23
0.5	3GPP Rel 6	HSDPA Subtest-3	21.71	21.84	21.96	22
0.5	3GPP Rel 6	HSDPA Subtest-4	21.68	21.82	21.94	22
0	3GPP Rel 6	HSUPA Subtest-1	21.97	21.91	21.96	22
2	3GPP Rel 6	HSUPA Subtest-2	21.28	21.25	21.40	22
1	3GPP Rel 6	HSUPA Subtest-3	20.93	21.03	20.99	22
2	3GPP Rel 6	HSUPA Subtest-4	21.39	21.29	21.56	22
0	3GPP Rel 6	HSUPA Subtest-5	22.10	22.30	22.30	23



<LTE Conducted Power>

General Note:

1. Anritsu MT8820C base station simulator was used to setup the connection with EUT; the frequency band, channel bandwidth, RB allocation configuration, modulation type are set in the base station simulator to configure EUT transmitting at maximum power and at different configurations which are requested to be reported to FCC, for conducted power measurement and SAR testing.
2. Per KDB 941225 D05v02r03, when a properly configured base station simulator is used for the SAR and power measurements, spectrum plots for each RB allocation and offset configuration is not required.
3. Per KDB 941225 D05v02r03, start with the largest channel bandwidth and measure SAR for QPSK with 1 RB allocation, using the RB offset and required test channel combination with the highest maximum output power for RB offsets at the upper edge, middle and lower edge of each required test channel.
4. Per KDB 941225 D05v02r03, 50% RB allocation for QPSK SAR testing follows 1RB QPSK allocation procedure.
5. Per KDB 941225 D05v02r03, For QPSK with 100% RB allocation, SAR is not required when the highest maximum output power for 100 % RB allocation is less than the highest maximum output power in 50% and 1 RB allocations and the highest reported SAR for 1 RB and 50% RB allocation are ≤ 0.8 W/kg. Otherwise, SAR is measured for the highest output power channel; and if the reported SAR is > 1.45 W/kg, the remaining required test channels must also be tested.
6. Per KDB 941225 D05v02r03, 16QAM output power for each RB allocation configuration is $>$ not $\frac{1}{2}$ dB higher than the same configuration in QPSK and the reported SAR for the QPSK configuration is ≤ 1.45 W/kg; Per KDB 941225 D05v02r03, 16QAM SAR testing is not required.
7. Per KDB 941225 D05v02r03, Smaller bandwidth output power for each RB allocation configuration is $>$ not $\frac{1}{2}$ dB higher than the same configuration in the largest supported bandwidth, and the reported SAR for the largest supported bandwidth is ≤ 1.45 W/kg; Per KDB 941225 D05v02r03, smaller bandwidth SAR testing is not required.



<LTE Band 12>

BW [MHz]	Modulation	RB Size	RB Offset	Power Low Ch. / Freq.	Power Middle Ch. / Freq.	Power High Ch. / Freq.	Tune up Limit (dBm)	MPR (dB)
Channel				23060	23095	23130		
Frequency (MHz)				704	707.5	711		
10	QPSK	1	0	23.33	23.28	23.49	24.5	0
10	QPSK	1	24	23.48	23.54	23.58		
10	QPSK	1	49	23.54	23.62	23.83		
10	QPSK	25	0	22.60	22.53	22.54	23.5	0-1
10	QPSK	25	12	22.46	22.55	22.58		
10	QPSK	25	24	22.49	22.62	22.57		
10	QPSK	50	0	22.59	22.58	22.59		
10	16QAM	1	0	22.42	22.00	22.15	23.5	0-1
10	16QAM	1	24	22.07	22.16	22.61		
10	16QAM	1	49	22.44	22.43	22.51		
10	16QAM	25	0	21.62	21.44	21.65	22.5	0-2
10	16QAM	25	12	21.61	21.56	21.63		
10	16QAM	25	24	21.59	21.64	21.60		
10	16QAM	50	0	21.60	21.62	21.58		
Channel				23035	23095	23155	Tune up Limit (dBm)	MPR (dB)
Frequency (MHz)				701.5	707.5	713.5		
5	QPSK	1	0	23.42	23.39	23.38	24.5	0
5	QPSK	1	12	23.33	23.64	23.35		
5	QPSK	1	24	23.72	23.35	23.66		
5	QPSK	12	0	22.48	22.48	22.48	23.5	0-1
5	QPSK	12	6	22.42	22.53	22.50		
5	QPSK	12	11	22.55	22.53	22.53		
5	QPSK	25	0	22.33	22.58	22.57		
5	16QAM	1	0	22.56	22.54	22.37	23.5	0-1
5	16QAM	1	12	22.03	22.30	22.64		
5	16QAM	1	24	22.26	22.69	22.24		
5	16QAM	12	0	21.86	21.56	21.54	22.5	0-2
5	16QAM	12	6	21.48	21.60	21.51		
5	16QAM	12	11	21.58	21.65	21.47		
5	16QAM	25	0	21.47	21.56	21.71		
Channel				23025	23095	23165	Tune up Limit (dBm)	MPR (dB)
Frequency (MHz)				700.5	707.5	714.5		
3	QPSK	1	0	23.31	23.30	23.41	24.5	0
3	QPSK	1	7	23.45	23.31	23.50		
3	QPSK	1	14	23.38	23.42	23.49		
3	QPSK	8	0	22.57	22.49	22.47	23.5	0-1
3	QPSK	8	4	22.53	22.55	22.44		
3	QPSK	8	7	22.56	22.61	22.44		
3	QPSK	15	0	22.56	22.54	22.49		
3	16QAM	1	0	22.47	22.67	22.15	23.5	0-1
3	16QAM	1	7	22.33	22.70	22.27		
3	16QAM	1	14	22.30	22.32	22.52		
3	16QAM	8	0	21.60	21.34	21.57	22.5	0-2
3	16QAM	8	4	21.53	21.77	21.62		
3	16QAM	8	7	21.60	21.46	21.49		
3	16QAM	15	0	21.55	21.73	21.46		



Channel				23017	23095	23173	Tune up Limit (dBm)	Target MPR (dB)
Frequency (MHz)				699.7	707.5	715.3		
1.4	QPSK	1	0	23.59	23.37	23.44	24.5	0
1.4	QPSK	1	2	23.40	23.44	23.34		
1.4	QPSK	1	5	23.32	23.52	23.50		
1.4	QPSK	3	0	23.55	23.47	23.40		
1.4	QPSK	3	1	23.36	23.49	23.48		
1.4	QPSK	3	2	23.57	23.47	23.47		
1.4	QPSK	6	0	22.51	22.51	22.77	23.5	0-1
1.4	16QAM	1	0	22.49	22.28	22.14	23.5	0-1
1.4	16QAM	1	2	22.43	22.20	22.66		
1.4	16QAM	1	5	22.40	22.46	22.69		
1.4	16QAM	3	0	22.31	22.43	22.33		
1.4	16QAM	3	1	22.46	22.41	22.65		
1.4	16QAM	3	2	22.47	22.44	22.18		
1.4	16QAM	6	0	21.56	21.42	21.43	22.5	0-2



<LTE Band 17 Conducted Power>

BW [MHz]	Modulation	RB Size	RB Offset	Power Low Ch. / Freq.	Power Middle Ch. / Freq.	Power High Ch. / Freq.	Tune up Limit (dBm)	MPR (dB)
Channel				23780	23790	23800		
Frequency (MHz)				709	710	711		
10	QPSK	1	0	23.19	23.27	23.35	24	0
10	QPSK	1	24	23.19	23.40	23.33		
10	QPSK	1	49	23.62	23.41	23.39		
10	QPSK	25	0	22.42	22.41	22.46	23	0-1
10	QPSK	25	12	22.57	22.36	22.64		
10	QPSK	25	24	22.51	22.61	22.46		
10	QPSK	50	0	22.49	22.46	22.47		
10	16QAM	1	0	22.14	22.14	22.27	23	0-1
10	16QAM	1	24	22.66	22.11	22.53		
10	16QAM	1	49	22.30	22.31	22.42		
10	16QAM	25	0	21.41	21.46	21.45	22	0-2
10	16QAM	25	12	21.64	21.75	21.41		
10	16QAM	25	24	21.51	21.74	21.46		
10	16QAM	50	0	21.53	21.46	21.51		
Channel				23755	23790	23825	Tune up Limit (dBm)	MPR (dB)
Frequency (MHz)				706.5	710	713.5		
5	QPSK	1	0	23.22	23.34	23.27	24	0
5	QPSK	1	12	23.29	23.13	23.46		
5	QPSK	1	24	23.51	23.60	23.41		
5	QPSK	12	0	22.30	22.33	22.37	23	0-1
5	QPSK	12	6	22.46	22.42	22.42		
5	QPSK	12	11	22.46	22.46	22.39		
5	QPSK	25	0	22.46	22.43	22.42		
5	16QAM	1	0	22.24	22.29	22.19	23	0-1
5	16QAM	1	12	22.25	22.18	22.26		
5	16QAM	1	24	22.53	22.47	22.17		
5	16QAM	12	0	21.40	21.45	21.45	22	0-2
5	16QAM	12	6	21.42	21.45	21.19		
5	16QAM	12	11	21.55	21.56	21.43		
5	16QAM	12	11	21.55	21.56	21.43		
5	16QAM	25	0	21.40	21.40	21.40		



<LTE Band 5>

BW [MHz]	Modulation	RB Size	RB Offset	Power Low Ch. / Freq.	Power Middle Ch. / Freq.	Power High Ch. / Freq.	Tune up Limit (dBm)	MPR (dB)
Channel				20450	20525	20600		
Frequency (MHz)				829	836.5	844		
10	QPSK	1	0	23.44	23.17	23.42	24	0
10	QPSK	1	24	23.46	23.46	23.57		
10	QPSK	1	49	23.26	23.40	23.39		
10	QPSK	25	0	22.57	22.36	22.39	23	0-1
10	QPSK	25	12	22.58	22.29	22.43		
10	QPSK	25	24	22.44	22.38	22.46		
10	QPSK	50	0	22.49	22.37	22.51		
10	16QAM	1	0	22.33	22.23	22.16	23	0-1
10	16QAM	1	24	22.62	22.19	22.56		
10	16QAM	1	49	22.45	22.49	22.54		
10	16QAM	25	0	21.50	21.42	21.46	22	0-2
10	16QAM	25	12	21.54	21.36	21.44		
10	16QAM	25	24	21.47	21.42	21.51		
10	16QAM	50	0	21.56	21.45	21.48		
Channel				20425	20525	20625		
Frequency (MHz)				826.5	836.5	846.5		
5	QPSK	1	0	23.38	23.22	23.34	24	0
5	QPSK	1	12	23.37	23.25	23.36		
5	QPSK	1	24	23.46	23.30	23.34		
5	QPSK	12	0	22.57	22.35	22.41	23	0-1
5	QPSK	12	6	22.54	22.30	22.48		
5	QPSK	12	11	22.39	22.31	22.45		
5	QPSK	25	0	22.54	22.36	22.45		
5	16QAM	1	0	22.60	22.06	22.68	23	0-1
5	16QAM	1	12	22.06	22.46	22.20		
5	16QAM	1	24	22.84	22.59	22.06		
5	16QAM	12	0	21.68	21.37	21.46	22	0-2
5	16QAM	12	6	21.67	21.48	21.40		
5	16QAM	12	11	21.49	21.38	21.51		
5	16QAM	25	0	21.52	21.40	21.47		
Channel				20415	20525	20635		
Frequency (MHz)				825.5	836.5	847.5		
3	QPSK	1	0	23.44	23.29	23.50	24	0
3	QPSK	1	7	23.49	23.15	23.37		
3	QPSK	1	14	23.36	23.39	23.26		
3	QPSK	8	0	22.58	22.32	22.49	23	0-1
3	QPSK	8	4	22.55	22.37	22.45		
3	QPSK	8	7	22.55	22.34	22.46		
3	QPSK	15	0	22.54	22.38	22.49		
3	16QAM	1	0	22.55	22.56	22.17	23	0-1
3	16QAM	1	7	22.24	22.53	22.25		
3	16QAM	1	14	22.44	22.57	22.67		
3	16QAM	8	0	21.49	21.38	21.60	22	0-2
3	16QAM	8	4	21.57	21.32	21.54		
3	16QAM	8	7	21.61	21.45	21.49		
3	16QAM	15	0	21.56	21.31	21.32		



Channel				20407	20525	20643	Tune up Limit (dBm)	Target MPR (dB)
Frequency (MHz)				824.7	836.5	848.3		
1.4	QPSK	1	0	23.41	23.25	23.42	24	0
1.4	QPSK	1	2	23.39	23.41	23.42		
1.4	QPSK	1	5	23.52	23.28	23.47		
1.4	QPSK	3	0	23.45	23.38	23.43		
1.4	QPSK	3	1	23.45	23.34	23.39		
1.4	QPSK	3	2	23.40	23.34	23.39		
1.4	QPSK	6	0	22.47	22.37	22.43	23	0-1
1.4	16QAM	1	0	22.34	22.04	22.71	23	0-1
1.4	16QAM	1	2	22.36	22.38	22.40		
1.4	16QAM	1	5	22.65	22.03	22.33		
1.4	16QAM	3	0	22.30	22.28	22.36		
1.4	16QAM	3	1	22.45	22.26	22.46		
1.4	16QAM	3	2	22.22	22.36	22.45		
1.4	16QAM	6	0	21.34	21.37	21.53	22	0-2



<LTE Band 26>

BW [MHz]	Modulation	RB Size	RB Offset	Power Low Ch. / Freq.	Power Middle Ch. / Freq.	Power High Ch. / Freq.	Tune up Limit (dBm)	MPR (dB)
Channel				26765	26865	26965		
Frequency (MHz)				821.5	831.5	841.5		
15	QPSK	1	0	23.39	23.32	23.34		
15	QPSK	1	37	23.33	23.28	23.26	24	0
15	QPSK	1	74	23.57	23.36	23.44		
15	QPSK	36	0	22.43	22.41	22.39		
15	QPSK	36	18	22.47	22.43	22.39	23	0-1
15	QPSK	36	37	22.46	22.42	22.41		
15	QPSK	75	0	22.45	22.45	22.45		
15	16QAM	1	0	22.33	22.46	22.11	23	0-1
15	16QAM	1	37	22.62	22.19	22.10		
15	16QAM	1	74	22.25	22.77	22.64		
15	16QAM	36	0	21.38	21.35	21.40	22	0-2
15	16QAM	36	18	21.49	21.36	21.51		
15	16QAM	36	37	21.33	21.36	21.40		
15	16QAM	75	0	21.48	21.45	21.46		
Channel				26740	26865	26990		
Frequency (MHz)				819	831.5	844		
10	QPSK	1	0	23.39	23.29	23.41		
10	QPSK	1	24	23.38	23.18	23.27	24	0
10	QPSK	1	49	23.42	23.38	23.36		
10	QPSK	25	0	22.40	22.39	22.41		
10	QPSK	25	12	22.36	22.43	22.44	23	0-1
10	QPSK	25	24	22.47	22.39	22.47		
10	QPSK	50	0	22.51	22.43	22.43		
10	16QAM	1	0	22.65	22.10	22.27	23	0-1
10	16QAM	1	24	22.13	22.24	22.23		
10	16QAM	1	49	22.24	21.95	22.70		
10	16QAM	25	0	21.45	21.43	21.39	22	0-2
10	16QAM	25	12	21.35	21.31	21.47		
10	16QAM	25	24	21.46	21.50	21.59		
10	16QAM	50	0	21.40	21.37	21.48		
Channel				26715	26865	27015		
Frequency (MHz)				816.5	831.5	846.5		
5	QPSK	1	0	23.37	23.19	23.41		
5	QPSK	1	12	23.27	23.35	23.53	24	0
5	QPSK	1	24	23.30	23.40	23.49		
5	QPSK	12	0	22.37	22.41	22.49		
5	QPSK	12	6	22.43	22.40	22.54	23	0-1
5	QPSK	12	11	22.46	22.36	22.52		
5	QPSK	25	0	22.42	22.43	22.52		
5	16QAM	1	0	22.22	22.03	22.63	23	0-1
5	16QAM	1	12	22.15	22.14	22.31		
5	16QAM	1	24	22.65	22.07	22.71		
5	16QAM	12	0	21.55	21.48	21.60	22	0-2
5	16QAM	12	6	21.37	21.33	21.51		
5	16QAM	12	11	21.44	21.40	21.51		
5	16QAM	25	0	21.47	21.38	21.48		



Channel				26705	26865	27025	Tune up Limit (dBm)	MPR (dB)
Frequency (MHz)				815.5	831.5	847.5		
3	QPSK	1	0	23.40	23.35	23.44	24	0
3	QPSK	1	7	23.39	23.30	23.54		
3	QPSK	1	14	23.37	23.37	23.42		
3	QPSK	8	0	22.32	22.40	22.58	23	0-1
3	QPSK	8	4	22.49	22.44	22.54		
3	QPSK	8	7	22.41	22.37	22.56		
3	QPSK	15	0	22.44	22.38	22.60		
3	16QAM	1	0	22.62	22.21	22.71	23	0-1
3	16QAM	1	7	22.21	22.18	22.72		
3	16QAM	1	14	22.61	22.20	22.36		
3	16QAM	8	0	21.55	21.42	21.59	22	0-2
3	16QAM	8	4	21.46	21.41	21.46		
3	16QAM	8	7	21.51	21.36	21.51		
3	16QAM	15	0	21.60	21.39	21.54		
Channel				26697	26865	27033	Tune up Limit (dBm)	MPR (dB)
Frequency (MHz)				814.7	831.5	848.3		
1.4	QPSK	1	0	23.40	23.34	23.52	24	0
1.4	QPSK	1	2	23.34	23.43	23.54		
1.4	QPSK	1	5	23.49	23.41	23.51		
1.4	QPSK	3	0	23.44	23.38	23.53		
1.4	QPSK	3	1	23.40	23.40	23.53		
1.4	QPSK	3	2	23.45	23.38	23.53		
1.4	QPSK	6	0	22.43	22.40	22.55	23	0-1
1.4	16QAM	1	0	22.37	22.37	22.83	23	0-1
1.4	16QAM	1	2	22.58	22.26	22.48		
1.4	16QAM	1	5	22.06	22.14	22.78		
1.4	16QAM	3	0	22.39	22.27	22.55		
1.4	16QAM	3	1	22.39	22.32	22.41		
1.4	16QAM	3	2	22.25	22.23	22.39		
1.4	16QAM	6	0	21.42	21.48	21.42	22	0-2



<LTE Band 4>

BW [MHz]	Modulation	RB Size	RB Offset	Power Low Ch. / Freq.	Power Middle Ch. / Freq.	Power High Ch. / Freq.	Tune up Limit (dBm)	MPR (dB)
Channel				20050	20175	20300		
Frequency (MHz)				1720	1732.5	1745		
20	QPSK	1	0	23.51	23.54	23.76		
20	QPSK	1	49	23.55	23.77	23.97	24.5	0
20	QPSK	1	99	23.51	23.63	23.78	24	0-1
20	QPSK	50	0	22.72	22.79	22.93		
20	QPSK	50	24	22.57	22.75	22.89		
20	QPSK	50	49	22.64	22.77	22.89	24	0-1
20	QPSK	100	0	22.60	22.75	22.85		
20	16QAM	1	0	22.23	23.01	22.94		
20	16QAM	1	49	22.38	22.63	22.93	24	0-1
20	16QAM	1	99	22.89	22.94	22.71	23	0-2
20	16QAM	50	0	21.57	21.75	21.79		
20	16QAM	50	24	21.59	21.67	21.85		
20	16QAM	50	49	21.63	21.77	21.84	23	0-2
20	16QAM	100	0	21.57	21.68	21.81		
Channel				20025	20175	20325		
Frequency (MHz)				1717.5	1732.5	1747.5	24.5	0
15	QPSK	1	0	23.61	23.60	23.58		
15	QPSK	1	37	23.43	23.71	23.84		
15	QPSK	1	74	23.44	23.67	23.71	24	0-1
15	QPSK	36	0	22.62	22.77	22.84		
15	QPSK	36	18	22.58	22.76	22.89		
15	QPSK	36	37	22.56	22.74	22.88	24	0-1
15	QPSK	75	0	22.59	22.76	22.91		
15	16QAM	1	0	22.76	22.57	23.03		
15	16QAM	1	37	22.10	22.66	23.09	24	0-1
15	16QAM	1	74	22.07	22.92	22.78	23	0-2
15	16QAM	36	0	21.46	21.73	21.84		
15	16QAM	36	18	21.49	21.73	21.77		
15	16QAM	36	37	21.49	21.70	21.83	23	0-2
15	16QAM	75	0	21.58	21.71	21.81		
Channel				20000	20175	20350		
Frequency (MHz)				1715	1732.5	1750	24.5	0
10	QPSK	1	0	23.44	23.70	23.92		
10	QPSK	1	24	23.41	23.68	23.75		
10	QPSK	1	49	23.52	23.72	23.76	24	0-1
10	QPSK	25	0	22.54	22.76	22.85		
10	QPSK	25	12	22.52	22.69	22.89		
10	QPSK	25	24	22.54	22.80	22.80	24	0-1
10	QPSK	50	0	22.64	22.82	22.95		
10	16QAM	1	0	22.67	22.75	22.64		
10	16QAM	1	24	22.61	22.32	22.65	24	0-1
10	16QAM	1	49	22.28	22.79	22.46	23	0-2
10	16QAM	25	0	21.60	21.73	21.96		
10	16QAM	25	12	21.64	21.75	21.82		
10	16QAM	25	24	21.52	21.75	21.84	23	0-2
10	16QAM	50	0	21.52	21.74	21.79		



Channel				19975	20175	20375	Tune up Limit (dBm)	MPR (dB)
Frequency (MHz)				1712.5	1732.5	1752.5		
5	QPSK	1	0	23.47	23.61	23.82	24.5	0
5	QPSK	1	12	23.45	23.68	23.67		
5	QPSK	1	24	23.41	23.73	23.78		
5	QPSK	12	0	22.51	22.77	22.82	24	0-1
5	QPSK	12	6	22.51	22.80	22.78		
5	QPSK	12	11	22.61	22.73	22.77		
5	QPSK	25	0	22.55	22.78	22.75		
5	16QAM	1	0	22.67	22.96	22.60	24	0-1
5	16QAM	1	12	22.69	22.27	22.49		
5	16QAM	1	24	22.19	22.51	22.55		
5	16QAM	12	0	21.61	21.71	21.86	23	0-2
5	16QAM	12	6	21.46	21.62	21.69		
5	16QAM	12	11	21.50	21.75	21.72		
5	16QAM	25	0	21.53	21.72	21.70		
5	16QAM	25	0	21.53	21.72	21.70		
Channel				19965	20175	20385	Tune up Limit (dBm)	MPR (dB)
Frequency (MHz)				1711.5	1732.5	1753.5		
3	QPSK	1	0	23.56	23.65	23.78	24.5	0
3	QPSK	1	7	23.53	23.67	23.80		
3	QPSK	1	14	23.52	23.69	23.78		
3	QPSK	8	0	22.51	22.71	22.76	24	0-1
3	QPSK	8	4	22.51	22.77	22.78		
3	QPSK	8	7	22.55	22.71	22.80		
3	QPSK	15	0	22.57	22.70	22.83		
3	16QAM	1	0	22.31	22.55	22.49		
3	16QAM	1	7	22.57	22.95	23.03	24	0-1
3	16QAM	1	14	22.58	22.60	23.06		
3	16QAM	8	0	21.63	21.80	21.82		
3	16QAM	8	4	21.64	21.68	21.88	23	0-2
3	16QAM	8	7	21.43	21.72	21.75		
3	16QAM	8	7	21.43	21.72	21.75		
3	16QAM	15	0	21.42	21.66	21.78		
Channel				19957	20175	20393	Tune up Limit (dBm)	MPR (dB)
Frequency (MHz)				1710.7	1732.5	1754.3		
1.4	QPSK	1	0	23.55	23.70	23.81	24.5	0
1.4	QPSK	1	2	23.59	23.82	23.78		
1.4	QPSK	1	5	23.49	23.79	23.85		
1.4	QPSK	3	0	23.53	23.78	23.82		
1.4	QPSK	3	1	23.57	23.77	23.82		
1.4	QPSK	3	2	23.56	23.77	23.81		
1.4	QPSK	6	0	23.57	23.76	23.81	24	0-1
1.4	16QAM	1	0	22.72	22.97	22.61	24	0-1
1.4	16QAM	1	2	22.63	22.84	23.01		
1.4	16QAM	1	5	22.41	22.91	22.94		
1.4	16QAM	3	0	22.55	22.74	22.85		
1.4	16QAM	3	1	22.52	22.73	22.67		
1.4	16QAM	3	2	22.50	22.55	22.67		
1.4	16QAM	6	0	22.49	22.55	22.66		



<LTE Band 2>

BW [MHz]	Modulation	RB Size	RB Offset	Power Low Ch. / Freq.	Power Middle Ch. / Freq.	Power High Ch. / Freq.	Tune up Limit (dBm)	MPR (dB)
Channel				18700	18900	19100		
Frequency (MHz)				1860	1880	1900		
20	QPSK	1	0	23.52	23.68	23.89	25	0
20	QPSK	1	49	23.41	23.63	23.75		
20	QPSK	1	99	23.50	23.58	23.77		
20	QPSK	50	0	23.47	23.63	23.73	24	0-1
20	QPSK	50	24	23.48	23.64	23.78		
20	QPSK	50	49	23.44	23.62	23.75		
20	QPSK	100	0	23.50	23.63	23.75		
20	16QAM	1	0	22.64	22.25	22.46	24	0-1
20	16QAM	1	49	22.63	22.40	22.78		
20	16QAM	1	99	22.24	22.70	22.43		
20	16QAM	50	0	22.52	22.59	22.77	23	0-2
20	16QAM	50	24	22.53	22.68	22.72		
20	16QAM	50	49	22.46	22.64	22.77		
20	16QAM	100	0	22.37	22.49	22.75		
Channel				18675	18900	19125	Tune up Limit (dBm)	MPR (dB)
Frequency (MHz)				1857.5	1880	1902.5		
15	QPSK	1	0	23.43	23.62	23.56	25	0
15	QPSK	1	37	23.43	23.63	23.70		
15	QPSK	1	74	23.55	23.73	23.68		
15	QPSK	36	0	23.47	23.69	23.63	24	0-1
15	QPSK	36	18	23.49	23.64	23.67		
15	QPSK	36	37	23.54	23.72	23.65		
15	QPSK	75	0	23.51	23.62	23.66		
15	16QAM	1	0	22.69	22.81	22.65	24	0-1
15	16QAM	1	37	22.36	22.34	22.52		
15	16QAM	1	74	22.40	22.56	22.76		
15	16QAM	36	0	22.53	22.50	22.73	23	0-2
15	16QAM	36	18	22.37	22.74	22.64		
15	16QAM	36	37	22.61	22.69	22.72		
15	16QAM	75	0	22.61	22.54	22.60		
Channel				18650	18900	19150	Tune up Limit (dBm)	MPR (dB)
Frequency (MHz)				1855	1880	1905		
10	QPSK	1	0	23.36	23.64	23.55	25	0
10	QPSK	1	24	23.48	23.54	23.51		
10	QPSK	1	49	23.39	23.55	23.64		
10	QPSK	25	0	23.39	23.61	23.62	24	0-1
10	QPSK	25	12	23.44	23.61	23.55		
10	QPSK	25	24	23.46	23.56	23.62		
10	QPSK	50	0	22.48	22.61	22.66		
10	16QAM	1	0	22.63	22.78	22.37	24	0-1
10	16QAM	1	24	22.24	22.35	22.77		
10	16QAM	1	49	22.57	22.46	22.32		
10	16QAM	25	0	22.62	22.65	22.74	23	0-2
10	16QAM	25	12	22.34	22.53	22.63		
10	16QAM	25	24	22.42	22.63	22.74		
10	16QAM	50	0	21.55	21.79	21.63		



Channel				18625	18900	19175	Tune up Limit (dBm)	MPR (dB)
Frequency (MHz)				1852.5	1880	1907.5		
5	QPSK	1	0	23.38	23.72	23.47	25	0
5	QPSK	1	12	23.47	23.73	23.57		
5	QPSK	1	24	23.42	23.63	23.42		
5	QPSK	12	0	23.42	23.71	23.55	24	0-1
5	QPSK	12	6	23.44	23.62	23.54		
5	QPSK	12	11	23.41	23.63	23.55		
5	QPSK	25	0	22.41	22.67	22.61	24	0-1
5	16QAM	1	0	22.30	22.71	22.31		
5	16QAM	1	12	22.46	22.40	22.42		
5	16QAM	1	24	22.62	22.37	22.68	23	0-2
5	16QAM	12	0	22.60	22.67	22.67		
5	16QAM	12	6	22.52	22.67	22.57		
5	16QAM	12	11	22.39	22.64	22.62	23	0-2
5	16QAM	12	11	22.39	22.64	22.62		
5	16QAM	25	0	21.45	21.69	21.64		
Channel				18615	18900	19185	Tune up Limit (dBm)	MPR (dB)
Frequency (MHz)				1851.5	1880	1908.5		
3	QPSK	1	0	23.57	23.72	23.51	25	0
3	QPSK	1	7	23.49	23.67	23.49		
3	QPSK	1	14	23.52	23.70	23.42		
3	QPSK	8	0	22.46	22.66	22.54	24	0-1
3	QPSK	8	4	22.48	22.57	22.53		
3	QPSK	8	7	22.48	22.70	22.52		
3	QPSK	15	0	22.43	22.61	22.57	24	0-1
3	16QAM	1	0	22.19	22.77	22.38		
3	16QAM	1	7	22.26	22.78	22.72		
3	16QAM	1	14	22.24	22.85	22.62	23	0-2
3	16QAM	8	0	21.56	21.72	21.57		
3	16QAM	8	4	21.53	21.81	21.56		
3	16QAM	8	7	21.54	21.73	21.58	23	0-2
3	16QAM	15	0	21.46	21.73	21.62		
Channel				18607	18900	19193	Tune up Limit (dBm)	MPR (dB)
Frequency (MHz)				1850.7	1880	1909.3		
1.4	QPSK	1	0	23.43	23.74	23.48	25	0
1.4	QPSK	1	2	23.60	23.83	23.63		
1.4	QPSK	1	5	23.50	23.70	23.56		
1.4	QPSK	3	0	23.48	23.72	23.60		
1.4	QPSK	3	1	23.47	23.80	23.59		
1.4	QPSK	3	2	23.47	23.80	23.60	24	0-1
1.4	QPSK	6	0	23.57	23.79	23.58		
1.4	16QAM	1	0	22.59	22.43	22.43	24	0-1
1.4	16QAM	1	2	22.32	22.53	22.37		
1.4	16QAM	1	5	22.57	22.71	22.57		
1.4	16QAM	3	0	22.46	22.61	22.40		
1.4	16QAM	3	1	22.45	22.69	22.40		
1.4	16QAM	3	2	22.56	22.40	22.30		
1.4	16QAM	6	0	22.36	22.51	22.44	23	0-2



<LTE Band 25>

BW [MHz]	Modulation	RB Size	RB Offset	Power Low Ch. / Freq.	Power Middle Ch. / Freq.	Power High Ch. / Freq.	Tune up Limit (dBm)	MPR (dB)
Channel				26140	26340	26590		
Frequency (MHz)				1860	1880	1905		
20	QPSK	1	0	23.78	23.89	24.01	25	0
20	QPSK	1	49	23.79	23.82	24.05		
20	QPSK	1	99	23.91	24.08	24.25		
20	QPSK	50	0	23.89	24.05	24.11	24.5	0-1
20	QPSK	50	24	23.82	24.04	24.10		
20	QPSK	50	49	23.87	24.04	24.08		
20	QPSK	100	0	23.86	24.03	24.17	24	0-1
20	16QAM	1	0	22.61	23.14	22.97		
20	16QAM	1	49	22.94	22.77	22.79		
20	16QAM	1	99	22.65	22.57	23.27	23.5	0-2
20	16QAM	50	0	22.77	23.00	23.05		
20	16QAM	50	24	22.91	23.05	23.22		
20	16QAM	50	49	22.91	23.07	23.13	23.5	0-2
20	16QAM	50	0	22.93	23.12	23.10		
Channel				26115	26340	26615		
Frequency (MHz)				1857.5	1880	1907.5		
15	QPSK	1	0	23.76	23.90	24.12	25	0
15	QPSK	1	37	23.89	24.08	24.05		
15	QPSK	1	74	23.78	24.03	24.00		
15	QPSK	36	0	23.79	24.03	24.11	24.5	0-1
15	QPSK	36	18	23.83	24.03	24.06		
15	QPSK	36	37	23.81	24.06	24.06		
15	QPSK	75	0	23.85	24.05	24.04	24	0-1
15	16QAM	1	0	22.79	22.50	22.70		
15	16QAM	1	37	22.99	23.26	23.05		
15	16QAM	1	74	22.71	23.15	22.81	23.5	0-2
15	16QAM	36	0	22.96	23.09	23.00		
15	16QAM	36	18	22.85	23.09	23.02		
15	16QAM	36	37	22.77	23.15	23.03	23.5	0-2
15	16QAM	75	0	22.75	23.02	22.97		
Channel				26090	26340	26640		
Frequency (MHz)				1855	1880	1910		
10	QPSK	1	0	23.84	24.06	23.99	25	0
10	QPSK	1	24	23.73	24.08	23.83		
10	QPSK	1	49	23.64	23.99	23.95		
10	QPSK	25	0	23.74	24.04	23.98	24.5	0-1
10	QPSK	25	12	23.82	24.07	23.90		
10	QPSK	25	24	23.79	24.05	23.98		
10	QPSK	50	0	22.84	23.14	22.91	24	0-1
10	16QAM	1	0	23.05	22.94	22.97		
10	16QAM	1	24	22.49	23.19	22.64		
10	16QAM	1	49	22.86	22.92	22.70	23.5	0-2
10	16QAM	25	0	22.80	23.15	22.95		
10	16QAM	25	12	22.82	23.13	22.96		
10	16QAM	25	24	22.90	23.16	22.95	23.5	0-2
10	16QAM	50	0	21.79	22.11	22.07		



Channel				26065	26340	26665	Tune up Limit (dBm)	MPR (dB)
Frequency (MHz)				1852.5	1880	1912.5		
5	QPSK	1	0	23.78	24.13	23.97	25	0
5	QPSK	1	12	23.72	24.05	23.70		
5	QPSK	1	24	23.79	24.08	23.96		
5	QPSK	12	0	23.77	24.10	23.95	24.5	0-1
5	QPSK	12	6	23.78	24.07	23.93		
5	QPSK	12	11	23.74	24.06	23.89		
5	QPSK	25	0	22.79	23.11	22.88	24	0-1
5	16QAM	1	0	22.43	23.12	22.50		
5	16QAM	1	12	22.50	23.24	22.95		
5	16QAM	1	24	22.83	23.19	22.57	23.5	0-2
5	16QAM	12	0	22.82	23.22	22.87		
5	16QAM	12	6	22.81	23.15	22.92		
5	16QAM	12	11	22.80	23.12	22.92	23.5	0-2
5	16QAM	25	0	21.75	22.23	22.14		
Channel				26055	26340	26675	Tune up Limit (dBm)	MPR (dB)
Frequency (MHz)				1851.5	1880	1913.5		
3	QPSK	1	0	23.82	24.12	23.92	25	0
3	QPSK	1	7	23.62	24.13	23.75		
3	QPSK	1	14	23.75	24.11	23.96		
3	QPSK	8	0	22.81	23.17	22.89	24.5	0-1
3	QPSK	8	4	22.77	23.09	22.85		
3	QPSK	8	7	22.81	23.10	22.93		
3	QPSK	15	0	22.78	23.13	22.91	24	0-1
3	16QAM	1	0	22.39	23.20	22.70		
3	16QAM	1	7	22.70	23.22	22.73		
3	16QAM	1	14	22.35	23.34	23.14	23.5	0-2
3	16QAM	8	0	21.79	22.29	21.92		
3	16QAM	8	4	21.87	22.31	22.12		
3	16QAM	8	7	21.92	22.30	22.06	23.5	0-2
3	16QAM	15	0	21.95	22.10	21.91		
Channel				26047	26340	26683	Tune up Limit (dBm)	MPR (dB)
Frequency (MHz)				1850.7	1880	1914.3		
1.4	QPSK	1	0	23.74	24.22	23.95	25	0
1.4	QPSK	1	2	23.82	24.15	24.06		
1.4	QPSK	1	5	23.90	24.16	23.91		
1.4	QPSK	3	0	23.86	24.15	24.03		
1.4	QPSK	3	1	23.88	24.14	24.00		
1.4	QPSK	3	2	23.85	24.14	24.05	24.5	0-1
1.4	QPSK	6	0	23.84	24.20	24.04		
1.4	16QAM	1	0	22.66	22.94	22.66	24	0-1
1.4	16QAM	1	2	22.65	23.34	22.92		
1.4	16QAM	1	5	22.97	22.94	22.77		
1.4	16QAM	3	0	22.75	22.99	22.84		
1.4	16QAM	3	1	22.73	22.88	22.91		
1.4	16QAM	3	2	22.72	23.02	22.83		
1.4	16QAM	6	0	22.74	22.87	22.90		



<LTE Band 7>

BW [MHz]	Modulation	RB Size	RB Offset	Power Low Ch. / Freq.	Power Middle Ch. / Freq.	Power High Ch. / Freq.	Tune up Limit (dBm)	MPR (dB)
Channel				20850	21100	21350		
Frequency (MHz)				2510	2535	2560		
20	QPSK	1	0	20.79	21.46	21.52		
20	QPSK	1	49	21.49	21.59	21.84	22	0
20	QPSK	1	99	20.88	21.55	21.39	21.5	0-1
20	QPSK	50	0	20.90	21.31	21.36		
20	QPSK	50	24	20.95	21.34	21.40		
20	QPSK	50	49	20.93	21.30	21.39		
20	QPSK	100	0	20.88	21.30	21.38	21	0-1
20	16QAM	1	0	19.80	20.34	20.71		
20	16QAM	1	49	20.02	20.65	20.67		
20	16QAM	1	99	19.99	20.32	20.40		
20	16QAM	50	0	19.86	20.35	20.57	21	0-2
20	16QAM	50	24	19.93	20.41	20.53		
20	16QAM	50	49	19.86	20.45	20.49		
20	16QAM	100	0	19.75	20.42	20.62		
Channel				20825	21100	21375		
Frequency (MHz)				2507.5	2535	2562.5		
15	QPSK	1	0	20.89	21.49	21.51		
15	QPSK	1	37	20.85	21.69	21.66	22	0
15	QPSK	1	74	20.87	21.59	21.71	21.5	0-1
15	QPSK	36	0	20.88	21.44	21.37		
15	QPSK	36	18	20.85	21.35	21.49		
15	QPSK	36	37	20.88	21.42	21.47		
15	QPSK	75	0	20.87	21.47	21.50	21	0-1
15	16QAM	1	0	19.51	20.64	20.33		
15	16QAM	1	37	19.59	20.77	20.83		
15	16QAM	1	74	19.98	20.48	20.68		
15	16QAM	36	0	19.95	20.74	20.79	21	0-2
15	16QAM	36	18	19.92	20.75	20.79		
15	16QAM	36	37	19.92	20.67	20.69		
15	16QAM	75	0	19.74	20.74	20.79		
Channel				20800	21100	21400		
Frequency (MHz)				2505	2535	2565		
10	QPSK	1	0	20.85	21.47	21.76		
10	QPSK	1	24	20.79	21.65	21.64	22	0
10	QPSK	1	49	20.68	21.64	21.79	21.5	0-1
10	QPSK	25	0	20.84	21.44	21.47		
10	QPSK	25	12	20.78	21.40	21.42		
10	QPSK	25	24	20.82	21.44	21.41		
10	QPSK	50	0	19.82	20.50	20.81	21	0-1
10	16QAM	1	0	19.59	20.70	20.74		
10	16QAM	1	24	19.88	20.88	20.60		
10	16QAM	1	49	19.52	20.47	20.86		
10	16QAM	25	0	19.72	20.68	20.82	21	0-2
10	16QAM	25	12	19.75	20.79	20.84		
10	16QAM	25	24	19.79	20.68	20.85		
10	16QAM	50	0	19.62	19.68	19.80		



Channel				20775	21100	21425	Tune up Limit (dBm)	MPR (dB)
Frequency (MHz)				2502.5	2535	2567.5		
5	QPSK	1	0	20.86	21.74	21.79	22	0
5	QPSK	1	12	20.82	21.67	21.77		
5	QPSK	1	24	20.75	21.70	21.67		
5	QPSK	12	0	20.83	21.43	21.46	21.5	0-1
5	QPSK	12	6	20.82	21.44	21.46		
5	QPSK	12	11	20.70	21.42	21.42		
5	QPSK	25	0	19.74	20.42	20.90		
5	16QAM	1	0	19.80	20.33	20.98	21	0-1
5	16QAM	1	12	19.99	20.56	20.74		
5	16QAM	1	24	19.55	20.88	20.51		
5	16QAM	12	0	19.94	20.81	20.97	21	0-2
5	16QAM	12	6	19.86	20.63	20.87		
5	16QAM	12	11	19.84	20.76	20.93		
5	16QAM	25	0	19.77	19.83	20.00		



<WLAN Conducted Power>

General Note:

- For 2.4GHz WLAN SAR testing, highest average RF output power channel for the lowest data rate for 802.11b were selected for SAR evaluation. 802.11g/n HT20 were not investigated since the average output powers over all channels and data rates were not more than 0.25 dB higher than the tested channel in the lowest data rate of 802.11b mode.

<2.4GHz WLAN>

WLAN 2.4GHz 802.11b Average Power (dBm)							Tune up Limit (dBm)
Power vs. Channel			Power vs. Data Rate				
Channel	Frequency (MHz)	Data Rate 1Mbps	2Mbps	5.5Mbps	11Mbps		
CH 1	2412	13.06	14.27	14.30	14.23	13.5	
CH 6	2437	14.07				14.5	
CH 11	2462	14.34				14.5	

WLAN 2.4GHz 802.11g Average Power (dBm)										Tune up Limit (dBm)
Power vs. Channel			Power vs. Data Rate							
Channel	Frequency (MHz)	Data Rate 6Mbps	9Mbps	12Mbps	18Mbps	24Mbps	36Mbps	48Mbps	54Mbps	
CH 1	2412	13.01	13.91	13.91	13.94	13.96	13.92	13.87	14.00	14.5
CH 6	2437	13.83								
CH 11	2462	14.05								

WLAN 2.4GHz 802.11n-HT20 Average Power (dBm)										Tune up Limit (dBm)
Power vs. Channel			Power vs. MCS Index							
Channel	Frequency (MHz)	MCS Index MCS0	MCS1	MCS2	MCS3	MCS4	MCS5	MCS6	MCS7	
CH 1	2412	12.05	12.67	12.66	12.64	12.64	12.69	12.68	12.57	13
CH 6	2437	12.58								
CH 11	2462	12.71								

13. Bluetooth Exclusions Applied

Mode Band	Average power(dBm)	
	Bluetooth v3.0+EDR	Bluetooth v4.0 LE
2.4GHz Bluetooth	3	-0.5

Note:

1. Per KDB 447498 D01v05r02, the 1-g and 10-g SAR test exclusion thresholds for 100 MHz to 6 GHz at *test separation distances* ≤ 50 mm are determined by:

$$[(\text{max. power of channel, including tune-up tolerance, mW}) / (\text{min. test separation distance, mm})] \cdot [\sqrt{f(\text{GHz})}] \leq 3.0 \text{ for 1-g SAR and } \leq 7.5 \text{ for 10-g extremity SAR}$$

- f(GHz) is the RF channel transmit frequency in GHz
- Power and distance are rounded to the nearest mW and mm before calculation
- The result is rounded to one decimal place for comparison

Bluetooth Max Power (dBm)	Separation Distance (mm)	Frequency (GHz)	exclusion thresholds
3	< 5	2.48	0.6

Note:

Per KDB 447498 D01v05r02, when the minimum test separation distance is < 5 mm, a distance of 5 mm is applied to determine SAR test exclusion. The test exclusion threshold is 0.6 which is ≤ 3, SAR testing is not required.

14. Antenna Location

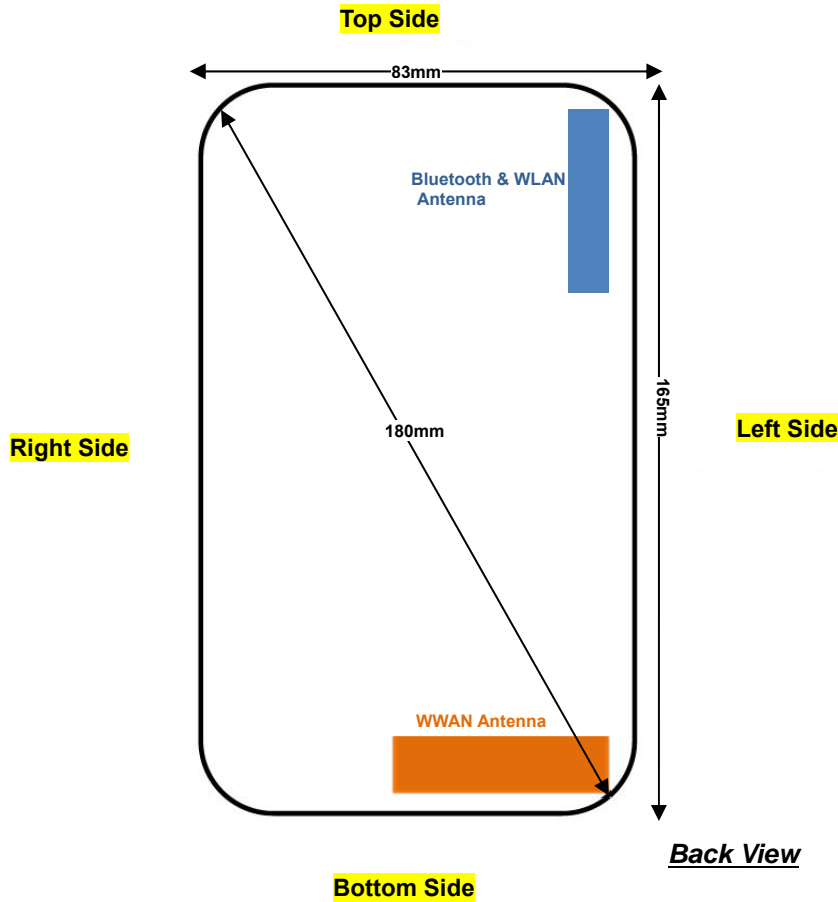

Distance of the Antenna to the EUT surface/edge						
Antennas	Back	Front	Top Side	Bottom Side	Right Side	Left Side
WWAN	≤ 25mm	≤ 25mm	155mm	≤ 25mm	51mm	≤ 25mm
BT&WLAN	≤ 25mm	≤ 25mm	≤ 25mm	143mm	73mm	≤ 25mm

Positions for SAR tests; Hotspot mode						
Antennas	Back	Front	Top Side	Bottom Side	Right Side	Left Side
WWAN	Yes	Yes	No	Yes	No	Yes
BT&WLAN	Yes	Yes	Yes	No	No	Yes

General Note:

Referring to KDB 941225 D06 v01r01, when the overall device length and width are ≥ 9cm*5cm, the test distance is 10 mm. SAR must be measured for all sides and surfaces with a transmitting antenna located within 25mm from that surface or edge.



15. SAR Test Results

General Note:

1. Per KDB 447498 D01v05r02, the reported SAR is the measured SAR value adjusted for maximum tune-up tolerance.
 - a. Tune-up scaling Factor = tune-up limit power (mW) / EUT RF power (mW), where tune-up limit is the maximum rated power among all production units.
 - b. For SAR testing of WLAN signal with non-100% duty cycle, the measured SAR is scaled-up by the duty cycle scaling factor which is equal to "1/(duty cycle)"
 - c. For WWAN: Reported SAR(W/kg)= Measured SAR(W/kg)*Tune-up Scaling Factor
 - d. For WLAN: Reported SAR(W/kg)= Measured SAR(W/kg)* Duty Cycle scaling factor * Tune-up scaling factor
802.11b duty cycle = 97.63%
2. Per KDB 447498 D01v05r02, for each exposure position, testing of other required channels within the operating mode of a frequency band is not required when the *reported* 1-g or 10-g SAR for the mid-band or highest output power channel is:
 - ≤ 0.8 W/kg or 2.0 W/kg, for 1-g or 10-g respectively, when the transmission band is ≤ 100 MHz
 - ≤ 0.6 W/kg or 1.5 W/kg, for 1-g or 10-g respectively, when the transmission band is between 100 MHz and 200 MHz
 - ≤ 0.4 W/kg or 1.0 W/kg, for 1-g or 10-g respectively, when the transmission band is ≥ 200 MHz
3. According to October 2013TCB Workshop, For GSM / GPRS / EGPRS, the number of time slots to test for SAR should correspond to the highest source-based time-averaged maximum output power configuration, Considering the possibility of e.g. 3rd party VoIP operation for head and body-worn SAR testing, the EUT was set in GPRS (2Tx slots) for GSM850/GSM1900 band due to its highest frame-average power.
4. For hotspot mode SAR testing, GPRS and EDGE should be evaluated, therefore the EUT was set in GPRS 2 Tx slots for GSM850/GSM1900 band due to its highest frame-average power.
5. Per KDB 648474 D04v01r02, when the reported SAR for a body-worn accessory measured without a headset connected to the handset is ≤ 1.2 W/kg, SAR testing with a headset connected to the handset is not required.
6. Per KDB 941225 D02v02r02, RMC 12.2kbps setting is used to evaluate SAR. If HSDPA/HSUPA output power is < 0.25 dB higher than RMC, or reported SAR with RMC 12.2kbps setting is ≤ 1.2 W/kg, HSDPA/HSUPA SAR evaluation can be excluded..
7. Per KDB 941225 D05v02r03, start with the largest channel bandwidth and measure SAR for QPSK with 1 RB allocation, using the RB offset and required test channel combination with the highest maximum output power for RB offsets at the upper edge, middle and lower edge of each required test channel.
8. Per KDB 941225 D05v02r03, 50% RB allocation for QPSK SAR testing follows 1RB QPSK allocation procedure.
9. Per KDB 941225 D05v02r03, For QPSK with 100% RB allocation, SAR is not required when the highest maximum output power for 100 % RB allocation is less than the highest maximum output power in 50% and 1 RB allocations and the highest reported SAR for 1 RB and 50% RB allocation are ≤ 0.8 W/kg. Otherwise, SAR is measured for the highest output power channel; and if the reported SAR is > 1.45 W/kg, the remaining required test channels must also be tested.
10. Per KDB 941225 D05v02r03, 16QAM output power for each RB allocation configuration is $>$ not $\frac{1}{2}$ dB higher than the same configuration in QPSK and the reported SAR for the QPSK configuration is ≤ 1.45 W/kg; Per KDB 941225 D05v02r03, 16QAM SAR testing is not required.
11. Per KDB 941225 D05v02r03, Smaller bandwidth output power for each RB allocation configuration is $>$ not $\frac{1}{2}$ dB higher than the same configuration in the largest supported bandwidth, and the reported SAR for the largest supported bandwidth is ≤ 1.45 W/kg; Per KDB 941225 D05v02r03, smaller bandwidth SAR testing is not required.
12. This device 2.4GHz WLAN supports Hotspot operation.
13. When hotspot mode applies, 10-g extremity SAR is required only for the surfaces and edges with hotspot mode 1-g SAR > 1.2 W/kg, and the limit for extremity SAR is 4.0W/kg as averaged over any 10 gram of tissue.

**15.1 Head SAR****<GSM SAR>**

Plot No.	Band	Mode	Test Position	Ch.	Freq. (MHz)	Average Power (dBm)	Tune-Up Limit (dBm)	Tune-up Scaling Factor	Power Drift (dB)	Measured 1g SAR (W/kg)	Reported 1g SAR (W/kg)
01	GSM850	GPRS(2 Tx slots)	Right Cheek	189	836.4	30.79	31.5	1.178	0.04	0.342	0.403
	GSM850	GPRS(2 Tx slots)	Right Tilted	189	836.4	30.79	31.5	1.178	0.03	0.147	0.173
	GSM850	GPRS(2 Tx slots)	Left Cheek	189	836.4	30.79	31.5	1.178	0.08	0.292	0.344
	GSM850	GPRS(2 Tx slots)	Left Tilted	189	836.4	30.79	31.5	1.178	0.07	0.146	0.172
	GSM1900	GPRS(2 Tx slots)	Right Cheek	661	1880	27.84	28.5	1.164	0.01	0.198	0.230
	GSM1900	GPRS(2 Tx slots)	Right Tilted	661	1880	27.84	28.5	1.164	0.02	0.082	0.095
02	GSM1900	GPRS(2 Tx slots)	Left Cheek	661	1880	27.84	28.5	1.164	-0.05	0.268	0.312
	GSM1900	GPRS(2 Tx slots)	Left Tilted	661	1880	27.84	28.5	1.164	-0.05	0.095	0.111

<WCDMA SAR>

Plot No.	Band	Mode	Test Position	Ch.	Freq. (MHz)	Average Power (dBm)	Tune-Up Limit (dBm)	Tune-up Scaling Factor	Power Drift (dB)	Measured 1g SAR (W/kg)	Reported 1g SAR (W/kg)
03	WCDMA Band V	RMC 12.2K	Right Cheek	4132	826.4	23.13	24	1.222	0.15	0.207	0.253
	WCDMA Band V	RMC 12.2K	Right Tilted	4132	826.4	23.13	24	1.222	0.09	0.095	0.116
	WCDMA Band V	RMC 12.2K	Left Cheek	4132	826.4	23.13	24	1.222	0.07	0.185	0.226
	WCDMA Band V	RMC 12.2K	Left Tilted	4132	826.4	23.13	24	1.222	0.01	0.099	0.121
	WCDMA Band IV	RMC 12.2K	Right Cheek	1513	1752.6	23.27	23.5	1.054	0.06	0.166	0.175
	WCDMA Band IV	RMC 12.2K	Right Tilted	1513	1752.6	23.27	23.5	1.054	0.13	0.105	0.111
34	WCDMA Band IV	RMC 12.2K	Left Cheek	1513	1752.6	23.27	23.5	1.054	0.03	0.280	0.295
	WCDMA Band IV	RMC 12.2K	Left Tilted	1513	1752.6	23.27	23.5	1.054	0.09	0.073	0.077
	WCDMA Band II	RMC 12.2K	Right Cheek	9538	1907.6	24.54	25	1.112	0.06	0.208	0.231
	WCDMA Band II	RMC 12.2K	Right Tilted	9538	1907.6	24.54	25	1.112	0.09	0.079	0.088
04	WCDMA Band II	RMC 12.2K	Left Cheek	9538	1907.6	24.54	25	1.112	0.01	0.301	0.335
	WCDMA Band II	RMC 12.2K	Left Tilted	9538	1907.6	24.54	25	1.112	0.01	0.114	0.127



<LTE SAR>

Plot No.	Band	BW (MHz)	Modulation	RB Size	RB offset	Test Position	Ch.	Freq. (MHz)	Average Power (dBm)	Tune-Up Limit (dBm)	Tune-up Scaling Factor	Power Drift (dB)	Measured 1g SAR (W/kg)	Reported 1g SAR (W/kg)
05	LTE Band 12	10M	QPSK	1	49	Right Cheek	23130	711	23.83	24.5	1.167	0.07	0.225	0.263
	LTE Band 12	10M	QPSK	1	49	Right Tilted	23130	711	23.83	24.5	1.167	0.03	0.099	0.116
	LTE Band 12	10M	QPSK	1	49	Left Cheek	23130	711	23.83	24.5	1.167	0.07	0.188	0.219
	LTE Band 12	10M	QPSK	1	49	Left Tilted	23130	711	23.83	24.5	1.167	0.02	0.085	0.099
	LTE Band 12	10M	QPSK	25	24	Right Cheek	23095	707.5	22.62	23.5	1.225	0.03	0.167	0.205
	LTE Band 12	10M	QPSK	25	24	Right Tilted	23095	707.5	22.62	23.5	1.225	0.06	0.074	0.091
	LTE Band 12	10M	QPSK	25	24	Left Cheek	23095	707.5	22.62	23.5	1.225	0.09	0.139	0.170
	LTE Band 12	10M	QPSK	25	24	Left Tilted	23095	707.5	22.62	23.5	1.225	0.05	0.062	0.076
06	LTE Band 17	10M	QPSK	1	49	Right Cheek	23780	709	23.62	24	1.091	0.06	0.214	0.234
	LTE Band 17	10M	QPSK	1	49	Right Tilted	23780	709	23.62	24	1.091	0.02	0.095	0.104
	LTE Band 17	10M	QPSK	1	49	Left Cheek	23780	709	23.62	24	1.091	0.07	0.209	0.228
	LTE Band 17	10M	QPSK	1	49	Left Tilted	23780	709	23.62	24	1.091	0.07	0.074	0.081
	LTE Band 17	10M	QPSK	25	12	Right Cheek	23800	711	22.64	23	1.086	0.09	0.168	0.183
	LTE Band 17	10M	QPSK	25	12	Right Tilted	23800	711	22.64	23	1.086	0.08	0.073	0.079
	LTE Band 17	10M	QPSK	25	12	Left Cheek	23800	711	22.64	23	1.086	0.04	0.164	0.178
	LTE Band 17	10M	QPSK	25	12	Left Tilted	23800	711	22.64	23	1.086	0.18	0.060	0.065
07	LTE Band 5	10M	QPSK	1	24	Right Cheek	20600	844	23.57	24	1.104	0.01	0.180	0.199
	LTE Band 5	10M	QPSK	1	24	Right Tilted	20600	844	23.57	24	1.104	0.08	0.073	0.081
	LTE Band 5	10M	QPSK	1	24	Left Cheek	20600	844	23.57	24	1.104	0.02	0.155	0.171
	LTE Band 5	10M	QPSK	1	24	Left Tilted	20600	844	23.57	24	1.104	-0.05	0.083	0.092
	LTE Band 5	10M	QPSK	25	12	Right Cheek	20450	829	22.58	23	1.102	0.08	0.164	0.181
	LTE Band 5	10M	QPSK	25	12	Right Tilted	20450	829	22.58	23	1.102	0.06	0.069	0.076
	LTE Band 5	10M	QPSK	25	12	Left Cheek	20450	829	22.58	23	1.102	0.08	0.143	0.158
	LTE Band 5	10M	QPSK	25	12	Left Tilted	20450	829	22.58	23	1.102	0.01	0.065	0.072



Plot No.	Band	BW (MHz)	Modulation	RB Size	RB offset	Test Position	Ch.	Freq. (MHz)	Average Power (dBm)	Tune-Up Limit (dBm)	Tune-up Scaling Factor	Power Drift (dB)	Measured 1g SAR (W/kg)	Reported 1g SAR (W/kg)
08	LTE Band 26	15M	QPSK	1	74	Right Cheek	26765	821.5	23.57	24	1.104	0.02	0.202	0.223
	LTE Band 26	15M	QPSK	1	74	Right Tilted	26765	821.5	23.57	24	1.104	0.08	0.083	0.092
	LTE Band 26	15M	QPSK	1	74	Left Cheek	26765	821.5	23.57	24	1.104	0.06	0.176	0.194
	LTE Band 26	15M	QPSK	1	74	Left Tilted	26765	821.5	23.57	24	1.104	0.01	0.079	0.087
	LTE Band 26	15M	QPSK	36	18	Right Cheek	26765	821.5	22.47	23	1.130	0.11	0.176	0.199
	LTE Band 26	15M	QPSK	36	18	Right Tilted	26765	821.5	22.47	23	1.130	0.02	0.078	0.088
	LTE Band 26	15M	QPSK	36	18	Left Cheek	26765	821.5	22.47	23	1.130	0.01	0.151	0.171
	LTE Band 26	15M	QPSK	36	18	Left Tilted	26765	821.5	22.47	23	1.130	0.06	0.073	0.082
	LTE Band 4	20M	QPSK	1	49	Right Cheek	20300	1745	23.97	24.5	1.130	0.03	0.215	0.243
	LTE Band 4	20M	QPSK	1	49	Right Tilted	20300	1745	23.97	24.5	1.130	0.06	0.150	0.169
	LTE Band 4	20M	QPSK	1	49	Left Cheek	20300	1745	23.97	24.5	1.130	-0.05	0.253	0.286
	LTE Band 4	20M	QPSK	1	49	Left Tilted	20300	1745	23.97	24.5	1.130	0.09	0.083	0.094
	LTE Band 4	20M	QPSK	50	0	Right Cheek	20300	1745	22.93	24	1.279	0.03	0.182	0.233
	LTE Band 4	20M	QPSK	50	0	Right Tilted	20300	1745	22.93	24	1.279	0.04	0.119	0.152
09	LTE Band 4	20M	QPSK	50	0	Left Cheek	20300	1745	22.93	24	1.279	-0.05	0.250	0.320
	LTE Band 4	20M	QPSK	50	0	Left Tilted	20300	1745	22.93	24	1.279	0.09	0.077	0.099
	LTE Band 2	20M	QPSK	1	0	Right Cheek	19100	1900	23.89	25	1.291	0.06	0.209	0.270
	LTE Band 2	20M	QPSK	1	0	Right Tilted	19100	1900	23.89	25	1.291	-0.04	0.074	0.096
10	LTE Band 2	20M	QPSK	1	0	Left Cheek	19100	1900	23.89	25	1.291	-0.09	0.245	0.316
	LTE Band 2	20M	QPSK	1	0	Left Tilted	19100	1900	23.89	25	1.291	0.08	0.073	0.094
	LTE Band 2	20M	QPSK	50	24	Right Cheek	19100	1900	23.78	24	1.052	0.09	0.151	0.159
	LTE Band 2	20M	QPSK	50	24	Right Tilted	19100	1900	23.78	24	1.052	0.03	0.054	0.057
	LTE Band 2	20M	QPSK	50	24	Left Cheek	19100	1900	23.78	24	1.052	0.08	0.193	0.203
	LTE Band 2	20M	QPSK	50	24	Left Tilted	19100	1900	23.78	24	1.052	-0.06	0.058	0.061
11	LTE Band 25	20M	QPSK	1	99	Right Cheek	26590	1905	24.25	25	1.189	0.01	0.202	0.240
	LTE Band 25	20M	QPSK	1	99	Right Tilted	26590	1905	24.25	25	1.189	-0.04	0.086	0.102
	LTE Band 25	20M	QPSK	1	99	Left Cheek	26590	1905	24.25	25	1.189	0.09	0.198	0.235
	LTE Band 25	20M	QPSK	1	99	Left Tilted	26590	1905	24.25	25	1.189	-0.04	0.066	0.078
	LTE Band 25	20M	QPSK	50	0	Right Cheek	26590	1905	24.11	24.5	1.094	0.08	0.169	0.185
	LTE Band 25	20M	QPSK	50	0	Right Tilted	26590	1905	24.11	24.5	1.094	0.04	0.056	0.061
	LTE Band 25	20M	QPSK	50	0	Left Cheek	26590	1905	24.11	24.5	1.094	0.08	0.212	0.232
	LTE Band 25	20M	QPSK	50	0	Left Tilted	26590	1905	24.11	24.5	1.094	0.03	0.065	0.071
	LTE Band 7	20M	QPSK	1	49	Right Cheek	21350	2560	21.84	22	1.038	0.08	0.00446	0.005
	LTE Band 7	20M	QPSK	1	49	Right Tilted	21350	2560	21.84	22	1.038	-0.01	0.00309	0.003
	LTE Band 7	20M	QPSK	1	49	Left Cheek	21350	2560	21.84	22	1.038	0.01	0.057	0.059
	LTE Band 7	20M	QPSK	1	49	Left Tilted	21350	2560	21.84	22	1.038	-0.05	0.0049	0.005
	LTE Band 7	20M	QPSK	50	24	Right Cheek	21350	2560	21.4	21.5	1.023	0.01	0.00715	0.007
	LTE Band 7	20M	QPSK	50	24	Right Tilted	21350	2560	21.4	21.5	1.023	-0.17	0.00321	0.003
12	LTE Band 7	20M	QPSK	50	24	Left Cheek	21350	2560	21.4	21.5	1.023	-0.07	0.060	0.061
	LTE Band 7	20M	QPSK	50	24	Left Tilted	21350	2560	21.4	21.5	1.023	0.09	0.00478	0.005



<DTS WLAN SAR>

Plot No.	Band	Mode	Test Position	Ch.	Freq. (MHz)	Average Power (dBm)	Tune-Up Limit (dBm)	Tune-up Scaling Factor	Duty Cycle Scaling Factor	Power Drift (dB)	Measured 1g SAR (W/kg)	Reported 1g SAR (W/kg)
	WLAN 2.4GHz	802.11b 1Mbps	Right Cheek	11	2462	14.34	14.5	1.038	1.024	0.06	1.060	1.126
	WLAN 2.4GHz	802.11b 1Mbps	Right Tilted	11	2462	14.34	14.5	1.038	1.024	0.08	0.793	0.843
	WLAN 2.4GHz	802.11b 1Mbps	Left Cheek	11	2462	14.34	14.5	1.038	1.024	0.08	0.396	0.421
	WLAN 2.4GHz	802.11b 1Mbps	Left Tilted	11	2462	14.34	14.5	1.038	1.024	0.04	0.275	0.292
	WLAN 2.4GHz	802.11b 1Mbps	Right Cheek	1	2412	13.06	13.5	1.107	1.024	0.08	1.110	1.258
13	WLAN 2.4GHz	802.11b 1Mbps	Right Cheek	6	2437	14.07	14.5	1.104	1.024	0.09	1.150	1.300
	WLAN 2.4GHz	802.11b 1Mbps	Right Tilted	1	2412	13.06	13.5	1.107	1.024	0.08	0.860	0.975
	WLAN 2.4GHz	802.11b 1Mbps	Right Tilted	6	2437	14.07	14.5	1.104	1.024	0.05	0.813	0.919

15.2 Hotspot SAR

Distance of the Antenna to the EUT surface/edge						
Antennas	Back	Front	Top Side	Bottom Side	Right Side	Left Side
WWAN	≤ 25mm	≤ 25mm	155mm	≤ 25mm	51mm	≤ 25mm
BT&WLAN	≤ 25mm	≤ 25mm	≤ 25mm	143mm	73mm	≤ 25mm

Positions for SAR tests; Hotspot mode						
Antennas	Back	Front	Top Side	Bottom Side	Right Side	Left Side
WWAN	Yes	Yes	No	Yes	No	Yes
BT&WLAN	Yes	Yes	Yes	No	No	Yes

General Note:

Referring to KDB 941225 D06 v01r01, when the overall device length and width are ≥ 9cm*5cm, the test distance is 10 mm. SAR must be measured for all sides and surfaces with a transmitting antenna located within 25mm from that surface or edge.

<GSM SAR>

Plot No.	Band	Mode	Test Position	Gap (cm)	Ch.	Freq. (MHz)	Average Power (dBm)	Tune-Up Limit (dBm)	Tune-up Scaling Factor	Power Drift (dB)	Measured 1g SAR (W/kg)	Reported 1g SAR (W/kg)
	GSM850	GPRS(2 Tx slots)	Front	1	189	836.4	30.79	31.5	1.178	0.07	0.429	0.505
14	GSM850	GPRS(2 Tx slots)	Back	1	189	836.4	30.79	31.5	1.178	0.03	0.498	0.586
	GSM850	GPRS(2 Tx slots)	Left Side	1	189	836.4	30.79	31.5	1.178	0.05	0.182	0.214
	GSM850	GPRS(2 Tx slots)	Bottom Side	1	189	836.4	30.79	31.5	1.178	0.09	0.271	0.319
	GSM1900	GPRS(2 Tx slots)	Front	1	661	1880	27.84	28.5	1.164	0.08	0.506	0.589
	GSM1900	GPRS(2 Tx slots)	Back	1	661	1880	27.84	28.5	1.164	0.03	0.569	0.662
	GSM1900	GPRS(2 Tx slots)	Left Side	1	661	1880	27.84	28.5	1.164	-0.08	0.346	0.403
15	GSM1900	GPRS(2 Tx slots)	Bottom Side	1	661	1880	27.84	28.5	1.164	-0.07	0.686	0.799

<WCDMA SAR>

Plot No.	Band	Mode	Test Position	Gap (cm)	Ch.	Freq. (MHz)	Average Power (dBm)	Tune-Up Limit (dBm)	Tune-up Scaling Factor	Power Drift (dB)	Measured 1g SAR (W/kg)	Reported 1g SAR (W/kg)
	WCDMA Band V	RMC 12.2K	Front	1	4132	826.4	23.13	24	1.222	0.01	0.248	0.303
16	WCDMA Band V	RMC 12.2K	Back	1	4132	826.4	23.13	24	1.222	0.08	0.305	0.373
	WCDMA Band V	RMC 12.2K	Left Side	1	4132	826.4	23.13	24	1.222	0.09	0.140	0.171
	WCDMA Band V	RMC 12.2K	Bottom Side	1	4132	826.4	23.13	24	1.222	-0.03	0.145	0.177
	WCDMA Band IV	RMC 12.2K	Front	1	1513	1752.6	23.27	23.5	1.054	0.06	0.532	0.561
	WCDMA Band IV	RMC 12.2K	Back	1	1513	1752.6	23.27	23.5	1.054	0.05	0.544	0.574
	WCDMA Band IV	RMC 12.2K	Left Side	1	1513	1752.6	23.27	23.5	1.054	0.07	0.343	0.362
35	WCDMA Band IV	RMC 12.2K	Bottom Side	1	1513	1752.6	23.27	23.5	1.054	0.09	0.650	0.685
	WCDMA Band II	RMC 12.2K	Front	1	9538	1907.6	24.54	25	1.112	-0.02	0.705	0.784
	WCDMA Band II	RMC 12.2K	Back	1	9538	1907.6	24.54	25	1.112	0.07	0.666	0.740
	WCDMA Band II	RMC 12.2K	Left Side	1	9538	1907.6	24.54	25	1.112	0.08	0.401	0.446
	WCDMA Band II	RMC 12.2K	Bottom Side	1	9538	1907.6	24.54	25	1.112	-0.02	1.030	1.145
17	WCDMA Band II	RMC 12.2K	Bottom Side	1	9262	1852.4	24.21	25	1.199	0.01	0.988	1.185
	WCDMA Band II	RMC 12.2K	Bottom Side	1	9400	1880	24.41	25	1.146	-0.02	0.994	1.139



<LTE SAR>

Plot No.	Band	BW (MHz)	Modulation	RB Size	RB offset	Test Position	Gap (cm)	Ch.	Freq. (MHz)	Average Power (dBm)	Tune-Up Limit (dBm)	Tune-up Scaling Factor	Power Drift (dB)	Measured 1g SAR (W/kg)	Reported 1g SAR (W/kg)
18	LTE Band 12	10M	QPSK	1	49	Front	1	23130	711	23.83	24.5	1.167	0.05	0.364	0.425
	LTE Band 12	10M	QPSK	1	49	Back	1	23130	711	23.83	24.5	1.167	0.08	0.264	0.308
	LTE Band 12	10M	QPSK	1	49	Left Side	1	23130	711	23.83	24.5	1.167	0.02	0.342	0.399
	LTE Band 12	10M	QPSK	1	49	Bottom Side	1	23130	711	23.83	24.5	1.167	-0.07	0.121	0.141
	LTE Band 12	10M	QPSK	25	24	Front	1	23095	707.5	22.62	23.5	1.225	0.06	0.286	0.350
	LTE Band 12	10M	QPSK	25	24	Back	1	23095	707.5	22.62	23.5	1.225	0.02	0.268	0.328
	LTE Band 12	10M	QPSK	25	24	Left Side	1	23095	707.5	22.62	23.5	1.225	0.07	0.275	0.337
	LTE Band 12	10M	QPSK	25	24	Bottom Side	1	23095	707.5	22.62	23.5	1.225	-0.07	0.089	0.109
19	LTE Band 17	10M	QPSK	1	49	Front	1	23780	709	23.62	24	1.091	0.01	0.349	0.381
	LTE Band 17	10M	QPSK	1	49	Back	1	23780	709	23.62	24	1.091	0.09	0.259	0.283
	LTE Band 17	10M	QPSK	1	49	Left Side	1	23780	709	23.62	24	1.091	0.04	0.337	0.368
	LTE Band 17	10M	QPSK	1	49	Bottom Side	1	23780	709	23.62	24	1.091	0.06	0.114	0.124
	LTE Band 17	10M	QPSK	25	12	Front	1	23800	711	22.64	23	1.086	0.03	0.286	0.311
	LTE Band 17	10M	QPSK	25	12	Back	1	23800	711	22.64	23	1.086	0.08	0.262	0.285
	LTE Band 17	10M	QPSK	25	12	Left Side	1	23800	711	22.64	23	1.086	0.05	0.274	0.298
	LTE Band 17	10M	QPSK	25	12	Bottom Side	1	23800	711	22.64	23	1.086	-0.05	0.089	0.097
20	LTE Band 5	10M	QPSK	1	24	Front	1	20600	844	23.57	24	1.104	0.06	0.264	0.291
	LTE Band 5	10M	QPSK	1	24	Back	1	20600	844	23.57	24	1.104	0.04	0.186	0.205
	LTE Band 5	10M	QPSK	1	24	Left Side	1	20600	844	23.57	24	1.104	0.01	0.108	0.119
	LTE Band 5	10M	QPSK	1	24	Bottom Side	1	20600	844	23.57	24	1.104	0.03	0.142	0.157
	LTE Band 5	10M	QPSK	25	12	Front	1	20450	829	22.58	23	1.102	0.04	0.226	0.249
	LTE Band 5	10M	QPSK	25	12	Back	1	20450	829	22.58	23	1.102	0.02	0.199	0.219
	LTE Band 5	10M	QPSK	25	12	Left Side	1	20450	829	22.58	23	1.102	0.04	0.095	0.105
	LTE Band 5	10M	QPSK	25	12	Bottom Side	1	20450	829	22.58	23	1.102	-0.07	0.115	0.127
21	LTE Band 26	15M	QPSK	1	74	Front	1	26765	821.5	23.57	24	1.104	0.05	0.268	0.296
	LTE Band 26	15M	QPSK	1	74	Back	1	26765	821.5	23.57	24	1.104	0.12	0.193	0.213
	LTE Band 26	15M	QPSK	1	74	Left Side	1	26765	821.5	23.57	24	1.104	0.04	0.112	0.124
	LTE Band 26	15M	QPSK	1	74	Bottom Side	1	26765	821.5	23.57	24	1.104	-0.02	0.139	0.153
	LTE Band 26	15M	QPSK	36	18	Front	1	26765	821.5	22.47	23	1.130	0.08	0.226	0.255
	LTE Band 26	15M	QPSK	36	18	Back	1	26765	821.5	22.47	23	1.130	0.03	0.199	0.225
	LTE Band 26	15M	QPSK	36	18	Left Side	1	26765	821.5	22.47	23	1.130	0.03	0.108	0.122
	LTE Band 26	15M	QPSK	36	18	Bottom Side	1	26765	821.5	22.47	23	1.130	0.04	0.114	0.129
	LTE Band 4	20M	QPSK	1	49	Front	1	20300	1745	23.97	24.5	1.130	0.06	0.572	0.646
	LTE Band 4	20M	QPSK	1	49	Back	1	20300	1745	23.97	24.5	1.130	0.05	0.683	0.772
22	LTE Band 4	20M	QPSK	1	49	Bottom Side	1	20300	1745	23.97	24.5	1.130	-0.09	0.713	0.806
	LTE Band 4	20M	QPSK	1	49	Bottom Side	1	20050	1720	23.55	24.5	1.245	-0.02	0.628	0.782
	LTE Band 4	20M	QPSK	1	49	Bottom Side	1	20175	1732.5	23.77	24.5	1.183	-0.09	0.672	0.795
	LTE Band 4	20M	QPSK	50	0	Front	1	20300	1745	22.93	24	1.279	0.1	0.584	0.747
	LTE Band 4	20M	QPSK	50	0	Back	1	20300	1745	22.93	24	1.279	0.07	0.554	0.709
	LTE Band 4	20M	QPSK	50	0	Left Side	1	20300	1745	22.93	24	1.279	0.06	0.418	0.535
	LTE Band 4	20M	QPSK	50	0	Bottom Side	1	20300	1745	22.93	24	1.279	-0.09	0.568	0.727
	LTE Band 4	20M	QPSK	100	0	Front	1	20300	1745	22.85	24	1.303	0.13	0.580	0.756
	LTE Band 4	20M	QPSK	100	0	Back	1	20300	1745	22.85	24	1.303	0.04	0.550	0.717
	LTE Band 4	20M	QPSK	100	0	Left Side	1	20300	1745	22.85	24	1.303	0.15	0.417	0.543
LTE Band 4	20M	QPSK	100	0	Bottom Side	1	20300	1745	22.85	24	1.303	0.02	0.584	0.761	



Plot No.	Band	BW (MHz)	Modulation	RB Size	RB offset	Test Position	Gap (cm)	Ch.	Freq. (MHz)	Average Power (dBm)	Tune-Up Limit (dBm)	Tune-up Scaling Factor	Power Drift (dB)	Measured 1g SAR (W/kg)	Reported 1g SAR (W/kg)
	LTE Band 2	20M	QPSK	1	0	Front	1	19100	1900	23.89	25	1.291	0.02	0.617	0.797
	LTE Band 2	20M	QPSK	1	0	Back	1	19100	1900	23.89	25	1.291	0.08	0.581	0.750
	LTE Band 2	20M	QPSK	1	0	Left Side	1	19100	1900	23.89	25	1.291	0.04	0.326	0.421
	LTE Band 2	20M	QPSK	1	0	Bottom Side	1	19100	1900	23.89	25	1.291	0.08	0.847	1.094
23	LTE Band 2	20M	QPSK	1	0	Bottom Side	1	18700	1860	23.52	25	1.406	0.03	0.820	1.153
	LTE Band 2	20M	QPSK	1	0	Bottom Side	1	18900	1880	23.68	25	1.355	0.03	0.838	1.136
	LTE Band 2	20M	QPSK	50	24	Front	1	19100	1900	23.78	24	1.052	0.01	0.485	0.510
	LTE Band 2	20M	QPSK	50	24	Back	1	19100	1900	23.78	24	1.052	0.04	0.455	0.479
	LTE Band 2	20M	QPSK	50	24	Left Side	1	19100	1900	23.78	24	1.052	0.04	0.256	0.269
	LTE Band 2	20M	QPSK	50	24	Bottom Side	1	19100	1900	23.78	24	1.052	-0.09	0.668	0.703
	LTE Band 2	20M	QPSK	100	0	Front	1	19100	1900	23.75	24	1.059	0.07	0.441	0.467
	LTE Band 2	20M	QPSK	100	0	Back	1	19100	1900	23.75	24	1.059	0.02	0.454	0.481
	LTE Band 2	20M	QPSK	100	0	Left Side	1	19100	1900	23.75	24	1.059	0.02	0.257	0.272
	LTE Band 2	20M	QPSK	100	0	Bottom Side	1	19100	1900	23.75	24	1.059	-0.06	0.666	0.705
	LTE Band 25	20M	QPSK	1	99	Front	1	26590	1905	24.25	25	1.189	0.04	0.541	0.643
	LTE Band 25	20M	QPSK	1	99	Back	1	26590	1905	24.25	25	1.189	0.07	0.64	0.761
	LTE Band 25	20M	QPSK	1	99	Left Side	1	26590	1905	24.25	25	1.189	0.01	0.281	0.334
	LTE Band 25	20M	QPSK	1	99	Bottom Side	1	26590	1905	24.25	25	1.189	-0.06	0.913	1.085
	LTE Band 25	20M	QPSK	1	99	Bottom Side	1	26140	1860	23.91	25	1.285	-0.04	0.883	1.135
24	LTE Band 25	20M	QPSK	1	99	Bottom Side	1	26340	1880	24.08	25	1.236	0.01	0.928	1.147
	LTE Band 25	20M	QPSK	50	0	Front	1	26590	1905	24.11	24.5	1.094	0.05	0.540	0.591
	LTE Band 25	20M	QPSK	50	0	Back	1	26590	1905	24.11	24.5	1.094	0.08	0.511	0.559
	LTE Band 25	20M	QPSK	50	0	Left Side	1	26590	1905	24.11	24.5	1.094	0.01	0.285	0.312
	LTE Band 25	20M	QPSK	50	0	Bottom Side	1	26590	1905	24.11	24.5	1.094	-0.01	0.728	0.796
	LTE Band 25	20M	QPSK	100	0	Front	1	26590	1905	24.17	24.5	1.079	0.08	0.495	0.534
	LTE Band 25	20M	QPSK	100	0	Back	1	26590	1905	24.17	24.5	1.079	0.01	0.507	0.547
	LTE Band 25	20M	QPSK	100	0	Left Side	1	26590	1905	24.17	24.5	1.079	0.08	0.282	0.304
	LTE Band 25	20M	QPSK	100	0	Bottom Side	1	26590	1905	24.17	24.5	1.079	0.02	0.730	0.788
	LTE Band 7	20M	QPSK	1	49	Front	1	21350	2560	21.84	22	1.038	0.02	0.346	0.359
	LTE Band 7	20M	QPSK	1	49	Back	1	21350	2560	21.84	22	1.038	0.03	0.558	0.579
	LTE Band 7	20M	QPSK	1	49	Left Side	1	21350	2560	21.84	22	1.038	0.08	0.172	0.178
	LTE Band 7	20M	QPSK	1	49	Bottom Side	1	21350	2560	21.84	22	1.038	-0.08	0.918	0.952
25	LTE Band 7	20M	QPSK	1	49	Bottom Side	1	20850	2510	21.49	22	1.125	0.03	1.280	1.439
	LTE Band 7	20M	QPSK	1	49	Bottom Side	1	21100	2535	21.59	22	1.099	0.02	1.190	1.308
	LTE Band 7	20M	QPSK	50	24	Front	1	21350	2560	21.4	21.5	1.023	-0.05	0.294	0.301
	LTE Band 7	20M	QPSK	50	24	Back	1	21350	2560	21.4	21.5	1.023	-0.02	0.454	0.465
	LTE Band 7	20M	QPSK	50	24	Left Side	1	21350	2560	21.4	21.5	1.023	0.06	0.139	0.142
	LTE Band 7	20M	QPSK	50	24	Bottom Side	1	21350	2560	21.4	21.5	1.023	0.07	0.746	0.763
	LTE Band 7	20M	QPSK	50	24	Bottom Side	1	20850	2510	20.95	21.5	1.135	0.1	1.030	1.169
	LTE Band 7	20M	QPSK	50	24	Bottom Side	1	21100	2535	21.34	21.5	1.038	-0.05	0.962	0.998
	LTE Band 7	20M	QPSK	100	0	Front	1	21350	2560	21.38	21.5	1.028	0.09	0.270	0.278
	LTE Band 7	20M	QPSK	100	0	Back	1	21350	2560	21.38	21.5	1.028	0.05	0.348	0.358
	LTE Band 7	20M	QPSK	100	0	Left Side	1	21350	2560	21.38	21.5	1.028	0.05	0.135	0.139
	LTE Band 7	20M	QPSK	100	0	Bottom Side	1	21350	2560	21.38	21.5	1.028	0.05	0.785	0.807



<DTS WLAN SAR>

Plot No.	Band	Mode	Test Position	Gap (cm)	Ch.	Freq. (MHz)	Average Power (dBm)	Tune-Up Limit (dBm)	Tune-up Scaling Factor	Duty Cycle Scaling Factor	Power Drift (dB)	Measured 1g SAR (W/kg)	Reported 1g SAR (W/kg)
	WLAN 2.4GHz	802.11b 1Mbps	Front	1	11	2462	14.34	14.5	1.038	1.024	0.01	0.296	0.314
26	WLAN 2.4GHz	802.11b 1Mbps	Back	1	11	2462	14.34	14.5	1.038	1.024	0.03	0.539	0.573
	WLAN 2.4GHz	802.11b 1Mbps	Left Side	1	11	2462	14.34	14.5	1.038	1.024	-0.03	0.317	0.337
	WLAN 2.4GHz	802.11b 1Mbps	Top Side	1	11	2462	14.34	14.5	1.038	1.024	0.01	0.175	0.186



15.3 Body Worn Accessory SAR

<GSM SAR>

Plot No.	Band	Mode	Test Position	Gap (cm)	Ch.	Freq. (MHz)	Average Power (dBm)	Tune-Up Limit (dBm)	Tune-up Scaling Factor	Power Drift (dB)	Measured 1g SAR (W/kg)	Reported 1g SAR (W/kg)
	GSM850	GPRS(2 Tx slots)	Front	1	189	836.4	30.79	31.5	1.178	0.07	0.429	0.505
14	GSM850	GPRS(2 Tx slots)	Back	1	189	836.4	30.79	31.5	1.178	0.03	0.498	0.586
	GSM1900	GPRS(2 Tx slots)	Front	1	661	1880	27.84	28.5	1.164	0.08	0.506	0.589
27	GSM1900	GPRS(2 Tx slots)	Back	1	661	1880	27.84	28.5	1.164	0.03	0.569	0.662

<WCDMA SAR>

Plot No.	Band	Mode	Test Position	Gap (cm)	Ch.	Freq. (MHz)	Average Power (dBm)	Tune-Up Limit (dBm)	Tune-up Scaling Factor	Power Drift (dB)	Measured 1g SAR (W/kg)	Reported 1g SAR (W/kg)
	WCDMA Band V	RMC 12.2K	Front	1	4132	826.4	23.13	24	1.222	0.01	0.248	0.303
16	WCDMA Band V	RMC 12.2K	Back	1	4132	826.4	23.13	24	1.222	0.08	0.305	0.373
	WCDMA Band IV	RMC 12.2K	Front	1	1513	1752.6	23.27	23.5	1.054	0.06	0.532	0.561
36	WCDMA Band IV	RMC 12.2K	Back	1	1513	1752.6	23.27	23.5	1.054	0.05	0.544	0.574
28	WCDMA Band II	RMC 12.2K	Front	1	9538	1907.6	24.54	25	1.112	-0.02	0.705	0.784
	WCDMA Band II	RMC 12.2K	Back	1	9538	1907.6	24.54	25	1.112	0.07	0.666	0.740

<LTE SAR>

Plot No.	Band	BW (MHz)	Modulation	RB Size	RB offset	Test Position	Gap (cm)	Ch.	Freq. (MHz)	Average Power (dBm)	Tune-Up Limit (dBm)	Tune-up Scaling Factor	Power Drift (dB)	Measured 1g SAR (W/kg)	Reported 1g SAR (W/kg)
18	LTE Band 12	10M	QPSK	1	49	Front	1	23130	711	23.83	24.5	1.167	0.05	0.364	0.425
	LTE Band 12	10M	QPSK	1	49	Back	1	23130	711	23.83	24.5	1.167	0.08	0.264	0.308
	LTE Band 12	10M	QPSK	25	24	Front	1	23095	707.5	22.62	23.5	1.225	0.06	0.286	0.350
	LTE Band 12	10M	QPSK	25	24	Back	1	23095	707.5	22.62	23.5	1.225	0.02	0.268	0.328
19	LTE Band 17	10M	QPSK	1	49	Front	1	23780	709	23.62	24	1.091	0.01	0.349	0.381
	LTE Band 17	10M	QPSK	1	49	Back	1	23780	709	23.62	24	1.091	0.09	0.259	0.283
	LTE Band 17	10M	QPSK	25	12	Front	1	23800	711	22.64	23	1.086	0.03	0.286	0.311
	LTE Band 17	10M	QPSK	25	12	Back	1	23800	711	22.64	23	1.086	0.08	0.262	0.285
20	LTE Band 5	10M	QPSK	1	24	Front	1	20600	844	23.57	24	1.104	0.06	0.264	0.291
	LTE Band 5	10M	QPSK	1	24	Back	1	20600	844	23.57	24	1.104	0.04	0.186	0.205
	LTE Band 5	10M	QPSK	25	12	Front	1	20450	829	22.58	23	1.102	0.04	0.226	0.249
	LTE Band 5	10M	QPSK	25	12	Back	1	20450	829	22.58	23	1.102	0.02	0.199	0.219
21	LTE Band 26	15M	QPSK	1	74	Front	1	26765	821.5	23.57	24	1.104	0.05	0.268	0.296
	LTE Band 26	15M	QPSK	1	74	Back	1	26765	821.5	23.57	24	1.104	0.12	0.193	0.213
	LTE Band 26	15M	QPSK	36	18	Front	1	26765	821.5	22.47	23	1.130	0.08	0.226	0.255
	LTE Band 26	15M	QPSK	36	18	Back	1	26765	821.5	22.47	23	1.130	0.03	0.199	0.225
	LTE Band 4	20M	QPSK	1	49	Front	1	20300	1745	23.97	24.5	1.130	0.06	0.572	0.646
29	LTE Band 4	20M	QPSK	1	49	Back	1	20300	1745	23.97	24.5	1.130	0.05	0.683	0.772
	LTE Band 4	20M	QPSK	50	0	Front	1	20300	1745	22.93	24	1.279	0.1	0.584	0.747
	LTE Band 4	20M	QPSK	50	0	Back	1	20300	1745	22.93	24	1.279	0.07	0.554	0.709
	LTE Band 4	20M	QPSK	100	0	Front	1	20300	1745	22.85	24	1.303	0.13	0.580	0.756
	LTE Band 4	20M	QPSK	100	0	Back	1	20300	1745	22.85	24	1.303	0.04	0.550	0.717



Plot No.	Band	BW (MHz)	Modulation	RB Size	RB offset	Test Position	Gap (cm)	Ch.	Freq. (MHz)	Average Power (dBm)	Tune-Up Limit (dBm)	Tune-up Scaling Factor	Power Drift (dB)	Measured 1g SAR (W/kg)	Reported 1g SAR (W/kg)
30	LTE Band 2	20M	QPSK	1	0	Front	1	19100	1900	23.89	25	1.291	0.02	0.617	0.797
	LTE Band 2	20M	QPSK	1	0	Back	1	19100	1900	23.89	25	1.291	0.08	0.581	0.750
	LTE Band 2	20M	QPSK	50	24	Front	1	19100	1900	23.78	24	1.052	0.01	0.485	0.510
	LTE Band 2	20M	QPSK	50	24	Back	1	19100	1900	23.78	24	1.052	0.04	0.455	0.479
	LTE Band 2	20M	QPSK	100	0	Front	1	19100	1900	23.75	24	1.059	0.07	0.441	0.467
	LTE Band 2	20M	QPSK	100	0	Back	1	19100	1900	23.75	24	1.059	0.02	0.454	0.481
	LTE Band 25	20M	QPSK	1	99	Front	1	26590	1905	24.25	25	1.189	0.04	0.541	0.643
31	LTE Band 25	20M	QPSK	1	99	Back	1	26590	1905	24.25	25	1.189	0.07	0.640	0.761
	LTE Band 25	20M	QPSK	50	0	Front	1	26590	1905	24.11	24.5	1.094	0.05	0.540	0.591
	LTE Band 25	20M	QPSK	50	0	Back	1	26590	1905	24.11	24.5	1.094	0.08	0.511	0.559
	LTE Band 25	20M	QPSK	100	0	Front	1	26590	1905	24.17	24.5	1.079	0.08	0.495	0.534
	LTE Band 25	20M	QPSK	100	0	Back	1	26590	1905	24.17	24.5	1.079	0.01	0.507	0.547
	LTE Band 7	20M	QPSK	1	49	Front	1	21350	2560	21.84	22	1.038	0.02	0.346	0.359
32	LTE Band 7	20M	QPSK	1	49	Back	1	21350	2560	21.84	22	1.038	0.03	0.558	0.579
	LTE Band 7	20M	QPSK	50	24	Front	1	21350	2560	21.4	21.5	1.023	-0.05	0.294	0.301
	LTE Band 7	20M	QPSK	50	24	Back	1	21350	2560	21.4	21.5	1.023	-0.02	0.454	0.465
	LTE Band 7	20M	QPSK	100	0	Front	1	21350	2560	21.38	21.5	1.028	0.09	0.270	0.278
	LTE Band 7	20M	QPSK	100	0	Back	1	21350	2560	21.38	21.5	1.028	0.05	0.348	0.358

<DTS WLAN SAR>

Plot No.	Band	Mode	Test Position	Gap (cm)	Ch.	Freq. (MHz)	Average Power (dBm)	Tune-Up Limit (dBm)	Tune-up Scaling Factor	Duty Cycle Scaling Factor	Power Drift (dB)	Measured 1g SAR (W/kg)	Reported 1g SAR (W/kg)
	WLAN 2.4GHz	802.11b 1Mbps	Front	1	11	2462	14.34	14.5	1.038	1.024	0.01	0.296	0.314
26	WLAN 2.4GHz	802.11b 1Mbps	Back	1	11	2462	14.34	14.5	1.038	1.024	0.03	0.539	0.573

15.4 Extremity SAR

Plot No.	Band	BW (MHz)	Modulation	RB Size	RB offset	Test Position	Gap (cm)	Ch.	Freq. (MHz)	Average Power (dBm)	Tune-Up Limit (dBm)	Tune-up Scaling Factor	Power Drift (dB)	Measured 10g SAR (W/kg)	Reported 10g SAR (W/kg)
33	LTE Band 7	20M	QPSK	1	49	Bottom Side	0	20850	2510	21.49	22	1.125	0.02	0.211	0.237

15.5 Repeated SAR Measurement

No.	Band	BW (MHz)	Mode	RB Size	RB offset	Test Position	Gap (cm)	Ch.	Freq. (MHz)	Average Power (dBm)	Tune-Up Limit (dBm)	Tune-up Scaling Factor	Duty Cycle Scaling Factor	Power Drift (dB)	Measured 1g SAR (W/kg)	Ratio	Reported 1g SAR (W/kg)
1st	WLAN 2.4GHz	-	802.11b 1Mbps	-	-	Right Cheek	-	6	2437	14.07	14.5	1.104	1.024	0.09	1.150	1	1.300
2nd	WLAN 2.4GHz	-	802.11b 1Mbps	-	-	Right Cheek	-	6	2437	14.07	14.5	1.104	1.024	0.02	1.130	1.017	1.278
1st	WCDMA Band II	-	RMC 12.2K	-	-	Bottom Side	1	9538	1907.6	24.54	25	1.112	-	-0.02	1.030	1	1.145
2nd	WCDMA Band II	-	RMC 12.2K	-	-	Bottom Side	1	9538	1907.6	24.54	25	1.112	-	0.06	0.985	1.044	1.095
1st	LTE Band 7	20M	QPSK	1	49	Bottom Side	1	20850	2510	21.49	22	1.125	-	0.03	1.280	1	1.439
2nd	LTE Band 7	20M	QPSK	1	49	Bottom Side	1	20850	2510	21.49	22	1.125	-	0.12	1.260	1.015	1.417

General Note:

1. Per KDB 865664 D01v01r03, for each frequency band, repeated SAR measurement is required only when the measured SAR is ≥ 0.8 W/kg
2. Per KDB 865664 D01v01r03, if the ratio among the repeated measurement is ≤ 1.2 and the measured SAR < 1.45 W/kg, only one repeated measurement is required.
3. The ratio is the difference in percentage between original and repeated *measured SAR*.
4. All measurement SAR result is scaled-up to account for tune-up tolerance and is compliant.

16. Simultaneous Transmission Analysis

NO.	Simultaneous Transmission Configurations	HP Slate 6 VoiceTab Plus			Note
		Head	Body-worn	Hotspot	
1.	GSM(Voice) + WLAN2.4GHz(data)	Yes	Yes		
2.	WCDMA(Voice) + WLAN2.4GHz(data)	Yes	Yes		
3.	GSM(Voice) + Bluetooth(data)	Yes	Yes		
4.	WCDMA((Voice) + Bluetooth(data)	Yes	Yes		
5.	GPRS/EDGE(Data) + WLAN2.4GHz(data)	Yes	Yes	Yes	2.4GHz Hotspot
6.	WCDMA(Data) + WLAN2.4GHz(data)	Yes	Yes	Yes	2.4GHz Hotspot
7.	LTE(Data) + WLAN2.4GHz(data)	Yes	Yes	Yes	2.4GHz Hotspot
8.	GPRS/EDGE(Data) + Bluetooth(data)	Yes	Yes	Yes	Bluetooth Tethering
9.	WCDMA(Data) + Bluetooth(data)	Yes	Yes	Yes	Bluetooth Tethering
10.	LTE(Data) + Bluetooth(data)	Yes	Yes	Yes	Bluetooth Tethering

General Note:

1. This device 2.4GHz WLAN supports Hotspot operation.
2. This device supported VoIP in GPRS/EGPRS, WCDMA and LTE (e.g. 3rd party VoIP).
3. WLAN and Bluetooth share the same antenna, and cannot transmit simultaneously.
4. EUT will choose each GSM, WCDMA and LTE according to the network signal condition; therefore, they will not operate simultaneously at any moment.
5. The reported SAR summation is calculated based on the same configuration and test position.
6. Per KDB 447498 D01v05r02, simultaneous transmission SAR is compliant if,
 - i) Scalar SAR summation < 1.6W/kg.
 - ii) $SPLSR = (SAR1 + SAR2)^{1.5} / (\text{min. separation distance, mm})$, and the peak separation distance is determined from the square root of $[(x1-x2)^2 + (y1-y2)^2 + (z1-z2)^2]$, where (x1, y1, z1) and (x2, y2, z2) are the coordinates of the extrapolated peak SAR locations in the zoom scan.
 - iii) If $SPLSR \leq 0.04$, simultaneously transmission SAR measurement is not necessary.
 - iv) Simultaneously transmission SAR measurement, and the reported multi-band SAR < 1.6W/kg.
7. For simultaneous transmission analysis, Bluetooth SAR is estimated per KDB 447498 D01v05r02 based on the formula below.
 - i) $(\text{max. power of channel, including tune-up tolerance, mW}) / (\text{min. test separation distance, mm}) \cdot [\sqrt{f(\text{GHz})} / x] \text{ W/kg}$ for test separation distances $\leq 50 \text{ mm}$; where $x = 7.5$ for 1-g SAR, and $x = 18.75$ for 10-g SAR.
 - ii) When the minimum separation distance is < 5mm, the distance is used 5mm to determine SAR test exclusion.
 - iii) 0.4 W/kg for 1-g SAR and 1.0 W/kg for 10-g SAR, when the test separation distances is > 50 mm.

Bluetooth Max Power	Exposure Position	Head	Hotspot	Body worn
	Test separation	0 mm	10 mm	10 mm
3 dBm	Estimated SAR (W/kg)	0.084 W/kg	0.042 W/kg	0.042 W/kg



16.1 Head Exposure Conditions

<WWAN + WLAN>

WWAN Band		Exposure Position	WWAN PCE	WLAN DTS	Summed SAR (W/kg)	SPLSR	Case No
			Max. WWAN SAR (W/kg)	Max. WLAN SAR (W/kg)			
GSM	GSM850	Right Cheek	0.403	1.300	1.70	0.03	#01
		Right Tilted	0.173	0.975	1.15		
		Left Cheek	0.344	0.421	0.77		
		Left Tilted	0.172	0.292	0.46		
	GSM1900	Right Cheek	0.230	1.300	1.53		
		Right Tilted	0.095	0.975	1.07		
		Left Cheek	0.312	0.421	0.73		
		Left Tilted	0.111	0.292	0.40		
WCMDA	Band V	Right Cheek	0.253	1.300	1.55		
		Right Tilted	0.116	0.975	1.09		
		Left Cheek	0.226	0.421	0.65		
		Left Tilted	0.121	0.292	0.41		
	Band IV	Right Cheek	0.175	1.300	1.48		
		Right Tilted	0.111	0.975	1.09		
		Left Cheek	0.295	0.421	0.72		
		Left Tilted	0.077	0.292	0.37		
	Band II	Right Cheek	0.231	1.300	1.53		
		Right Tilted	0.088	0.975	1.06		
		Left Cheek	0.335	0.421	0.76		
		Left Tilted	0.127	0.292	0.42		
LTE	Band 12	Right Cheek	0.263	1.300	1.56		
		Right Tilted	0.116	0.975	1.09		
		Left Cheek	0.219	0.421	0.64		
		Left Tilted	0.099	0.292	0.39		
	Band 17	Right Cheek	0.234	1.300	1.53		
		Right Tilted	0.104	0.975	1.08		
		Left Cheek	0.228	0.421	0.65		
		Left Tilted	0.081	0.292	0.37		
	Band 5	Right Cheek	0.199	1.300	1.50		
		Right Tilted	0.081	0.975	1.06		
		Left Cheek	0.171	0.421	0.59		
		Left Tilted	0.092	0.292	0.38		
	Band 26	Right Cheek	0.223	1.300	1.52		
		Right Tilted	0.092	0.975	1.07		
		Left Cheek	0.194	0.421	0.62		
		Left Tilted	0.087	0.292	0.38		
	Band 4	Right Cheek	0.243	1.300	1.54		
		Right Tilted	0.169	0.975	1.14		
		Left Cheek	0.320	0.421	0.74		
		Left Tilted	0.099	0.292	0.39		



WWAN Band		Exposure Position	WWAN PCE	WLAN DTS	Summed SAR (W/kg)	SPLSR	Case No
			Max. WWAN SAR (W/kg)	Max. WLAN SAR (W/kg)			
LTE	Band 2	Right Cheek	0.270	1.300	1.57		
		Right Tilted	0.096	0.975	1.07		
		Left Cheek	0.316	0.421	0.74		
		Left Tilted	0.094	0.292	0.39		
	Band 25	Right Cheek	0.240	1.300	1.54		
		Right Tilted	0.102	0.975	1.08		
		Left Cheek	0.235	0.421	0.66		
		Left Tilted	0.078	0.292	0.37		
	Band 7	Right Cheek	0.007	1.300	1.31		
		Right Tilted	0.003	0.975	0.98		
		Left Cheek	0.061	0.421	0.48		
		Left Tilted	0.005	0.292	0.30		



<WWAN + Bluetooth>

WWAN Band		Exposure Position	WWAN PCE	Bluetooth DSS	Summed SAR (W/kg)	SPLSR	Case No
			Max. WWAN SAR (W/kg)	Max. Bluetooth SAR (W/kg)			
GSM	GSM850	Right Cheek	0.403	0.084	0.49		
		Right Tilted	0.173	0.084	0.26		
		Left Cheek	0.344	0.084	0.43		
		Left Tilted	0.172	0.084	0.26		
	GSM1900	Right Cheek	0.230	0.084	0.31		
		Right Tilted	0.095	0.084	0.18		
		Left Cheek	0.312	0.084	0.40		
		Left Tilted	0.111	0.084	0.20		
WCMDA	Band V	Right Cheek	0.253	0.084	0.34		
		Right Tilted	0.116	0.084	0.20		
		Left Cheek	0.226	0.084	0.31		
		Left Tilted	0.121	0.084	0.21		
	Band IV	Right Cheek	0.175	0.084	0.26		
		Right Tilted	0.111	0.084	0.20		
		Left Cheek	0.295	0.084	0.38		
		Left Tilted	0.077	0.084	0.16		
	Band II	Right Cheek	0.231	0.084	0.32		
		Right Tilted	0.088	0.084	0.17		
		Left Cheek	0.335	0.084	0.42		
		Left Tilted	0.127	0.084	0.21		
LTE	Band 12	Right Cheek	0.263	0.084	0.35		
		Right Tilted	0.116	0.084	0.20		
		Left Cheek	0.219	0.084	0.30		
		Left Tilted	0.099	0.084	0.18		
	Band 17	Right Cheek	0.234	0.084	0.32		
		Right Tilted	0.104	0.084	0.19		
		Left Cheek	0.228	0.084	0.31		
		Left Tilted	0.081	0.084	0.17		
	Band 5	Right Cheek	0.199	0.084	0.28		
		Right Tilted	0.081	0.084	0.17		
		Left Cheek	0.171	0.084	0.26		
		Left Tilted	0.092	0.084	0.18		
	Band 26	Right Cheek	0.223	0.084	0.31		
		Right Tilted	0.092	0.084	0.18		
		Left Cheek	0.194	0.084	0.28		
		Left Tilted	0.087	0.084	0.17		
	Band 4	Right Cheek	0.243	0.084	0.33		
		Right Tilted	0.169	0.084	0.25		
		Left Cheek	0.320	0.084	0.40		
		Left Tilted	0.099	0.084	0.18		



WWAN Band		Exposure Position	WWAN PCE	Bluetooth DSS	Summed SAR (W/kg)	SPLSR	Case No
			Max. WWAN SAR (W/kg)	Max. Bluetooth SAR (W/kg)			
LTE	Band 2	Right Cheek	0.270	0.084	0.35		
		Right Tilted	0.096	0.084	0.18		
		Left Cheek	0.316	0.084	0.40		
		Left Tilted	0.094	0.084	0.18		
	Band 25	Right Cheek	0.240	0.084	0.32		
		Right Tilted	0.102	0.084	0.19		
		Left Cheek	0.235	0.084	0.32		
		Left Tilted	0.078	0.084	0.16		
	Band 7	Right Cheek	0.007	0.084	0.09		
		Right Tilted	0.003	0.084	0.09		
		Left Cheek	0.061	0.084	0.15		
		Left Tilted	0.005	0.084	0.09		



16.2 Hotspot Exposure Conditions

<WWAN + WLAN>

WWAN Band		Exposure Position	WWAN PCE	WLAN DTS	Summed SAR (W/kg)	SPLSR	Case No
			Max. WWAN SAR (W/kg)	Max. WLAN SAR (W/kg)			
GSM	GSM850	Front	0.505	0.314	0.82		
		Back	0.586	0.573	1.16		
		Left side	0.214	0.337	0.55		
		Top Side		0.186	0.19		
		Bottom side	0.319		0.32		
	GSM1900	Front	0.589	0.314	0.90		
		Back	0.662	0.573	1.24		
		Left side	0.403	0.337	0.74		
		Top Side		0.186	0.19		
		Bottom side	0.799		0.80		
WCMDA	Band V	Front	0.303	0.314	0.62		
		Back	0.373	0.573	0.95		
		Left side	0.171	0.337	0.51		
		Top Side		0.186	0.19		
		Bottom side	0.177		0.18		
	Band IV	Front	0.561	0.314	0.88		
		Back	0.574	0.573	1.15		
		Left side	0.362	0.337	0.70		
		Top Side		0.186	0.19		
		Bottom side	0.685		0.69		
	Band II	Front	0.784	0.314	1.10		
		Back	0.740	0.573	1.31		
		Left side	0.446	0.337	0.78		
		Top Side		0.186	0.19		
		Bottom side	1.185		1.19		
LTE	Band 12	Front	0.425	0.314	0.74		
		Back	0.328	0.573	0.90		
		Left side	0.399	0.337	0.74		
		Top Side		0.186	0.19		
		Bottom side	0.141		0.14		
	Band 17	Front	0.381	0.314	0.70		
		Back	0.285	0.573	0.86		
		Left side	0.368	0.337	0.71		
		Top Side		0.186	0.19		
		Bottom side	0.124		0.12		
	Band 5	Front	0.291	0.314	0.61		
		Back	0.219	0.573	0.79		
		Left side	0.119	0.337	0.46		
		Top Side		0.186	0.19		
		Bottom side	0.157		0.16		

WWAN Band		Exposure Position	WWAN PCE	WLAN DTS	Summed SAR (W/kg)	SPLSR	Case No
			Max. WWAN SAR (W/kg)	Max. WLAN SAR (W/kg)			
LTE	Band 26	Front	0.296	0.314	0.61		
		Back	0.225	0.573	0.80		
		Left side	0.124	0.337	0.46		
		Top Side		0.186	0.19		
		Bottom side	0.153		0.15		
	Band 4	Front	0.756	0.314	1.07		
		Back	0.772	0.573	1.35		
		Left side	0.575	0.337	0.91		
		Top Side		0.186	0.19		
		Bottom side	0.806		0.81		
	Band 2	Front	0.797	0.314	1.11		
		Back	0.750	0.573	1.32		
		Left side	0.421	0.337	0.76		
		Top Side		0.186	0.19		
		Bottom side	1.153		1.15		
	Band 25	Front	0.643	0.314	0.96		
		Back	0.761	0.573	1.33		
		Left side	0.334	0.337	0.67		
		Top Side		0.186	0.19		
		Bottom side	1.147		1.15		
Band 7	Front	0.359	0.314	0.67			
	Back	0.579	0.573	1.15			
	Left side	0.178	0.337	0.52			
	Top Side		0.186	0.19			
	Bottom side	1.439		1.44			



<WWAN + Bluetooth >

WWAN Band		Exposure Position	WWAN PCE	Bluetooth DSS	Summed SAR (W/kg)	SPLSR	Case No
			Max. WWAN SAR (W/kg)	Max. Bluetooth SAR (W/kg)			
GSM	GSM850	Front	0.505	0.042	0.55		
		Back	0.586	0.042	0.63		
		Left side	0.214	0.042	0.26		
		Top Side		0.042	0.04		
		Bottom side	0.319		0.32		
	GSM1900	Front	0.589	0.042	0.63		
		Back	0.662	0.042	0.70		
		Left side	0.403	0.042	0.45		
		Top Side		0.042	0.04		
		Bottom side	0.799		0.80		
WCDMA	Band V	Front	0.303	0.042	0.35		
		Back	0.373	0.042	0.42		
		Left side	0.171	0.042	0.21		
		Top Side		0.042	0.04		
		Bottom side	0.177		0.18		
	Band IV	Front	0.561	0.042	0.60		
		Back	0.574	0.042	0.62		
		Left side	0.362	0.042	0.40		
		Top Side		0.042	0.04		
		Bottom side	0.685		0.69		
	Band II	Front	0.784	0.042	0.83		
		Back	0.74	0.042	0.78		
		Left side	0.446	0.042	0.49		
		Top Side		0.042	0.04		
		Bottom side	1.185		1.19		
LTE	Band 12	Front	0.425	0.042	0.47		
		Back	0.328	0.042	0.37		
		Left side	0.399	0.042	0.44		
		Top Side		0.042	0.04		
		Bottom side	0.141		0.14		
	Band 17	Front	0.381	0.042	0.42		
		Back	0.285	0.042	0.33		
		Left side	0.368	0.042	0.41		
		Top Side		0.042	0.04		
		Bottom side	0.124		0.12		
	Band 5	Front	0.291	0.042	0.33		
		Back	0.219	0.042	0.26		
		Left side	0.119	0.042	0.16		
		Top Side		0.042	0.04		
		Bottom side	0.157		0.16		

WWAN Band		Exposure Position	WWAN PCE	Bluetooth DSS	Summed SAR (W/kg)	SPLSR	Case No
			Max. WWAN SAR (W/kg)	Max. Bluetooth SAR (W/kg)			
LTE	Band 26	Front	0.296	0.042	0.34		
		Back	0.225	0.042	0.27		
		Left side	0.124	0.042	0.17		
		Top Side		0.042	0.04		
		Bottom side	0.153		0.15		
	Band 4	Front	0.756	0.042	0.80		
		Back	0.772	0.042	0.81		
		Left side	0.575	0.042	0.62		
		Top Side		0.042	0.04		
		Bottom side	0.806		0.81		
	Band 2	Front	0.797	0.042	0.84		
		Back	0.750	0.042	0.79		
		Left side	0.421	0.042	0.46		
		Top Side		0.042	0.04		
		Bottom side	1.153		1.15		
	Band 25	Front	0.643	0.042	0.69		
		Back	0.761	0.042	0.80		
		Left side	0.334	0.042	0.38		
		Top Side		0.042	0.04		
		Bottom side	1.147		1.15		
Band 7	Front	0.359	0.042	0.40			
	Back	0.579	0.042	0.62			
	Left side	0.178	0.042	0.22			
	Top Side		0.042	0.04			
	Bottom side	1.439		1.44			



16.3 Body-Worn Accessory Exposure Conditions

<WWAN + WLAN>

WWAN Band		Exposure Position	WWAN PCE	WLAN DTS	Summed SAR (W/kg)	SPLSR	Case No
			Max. WWAN SAR (W/kg)	Max. WLAN SAR (W/kg)			
GSM	GSM850	Front	0.505	0.314	0.82		
		Back	0.586	0.573	1.16		
	GSM1900	Front	0.589	0.314	0.90		
		Back	0.662	0.573	1.24		
WCMDA	Band V	Front	0.303	0.314	0.62		
		Back	0.373	0.573	0.95		
	Band II	Front	0.784	0.314	1.10		
		Back	0.740	0.573	1.31		
LTE	Band 12	Front	0.425	0.314	0.74		
		Back	0.328	0.573	0.90		
	Band 17	Front	0.381	0.314	0.70		
		Back	0.285	0.573	0.86		
	Band 5	Front	0.291	0.314	0.61		
		Back	0.219	0.573	0.79		
	Band 26	Front	0.296	0.314	0.61		
		Back	0.225	0.573	0.80		
	Band 4	Front	0.756	0.314	1.07		
		Back	0.772	0.573	1.35		
	Band 2	Front	0.797	0.314	1.11		
		Back	0.750	0.573	1.32		
	Band 25	Front	0.643	0.314	0.96		
		Back	0.761	0.573	1.33		
	Band 7	Front	0.359	0.314	0.67		
		Back	0.579	0.573	1.15		



<WWAN + Bluetooth >

WWAN Band		Exposure Position	WWAN PCE	Bluetooth DSS	Summed SAR (W/kg)	SPLSR	Case No
			Max. WWAN SAR (W/kg)	Max. Bluetooth SAR (W/kg)			
GSM	GSM850	Front	0.505	0.042	0.55		
		Back	0.586	0.042	0.63		
	GSM1900	Front	0.589	0.042	0.63		
		Back	0.662	0.042	0.70		
WCMDA	Band V	Front	0.303	0.042	0.35		
		Back	0.373	0.042	0.42		
	Band II	Front	0.784	0.042	0.83		
		Back	0.740	0.042	0.78		
LTE	Band 12	Front	0.425	0.042	0.47		
		Back	0.328	0.042	0.37		
	Band 17	Front	0.381	0.042	0.42		
		Back	0.285	0.042	0.33		
	Band 5	Front	0.291	0.042	0.33		
		Back	0.219	0.042	0.26		
	Band 26	Front	0.296	0.042	0.34		
		Back	0.225	0.042	0.27		
	Band 4	Front	0.756	0.042	0.80		
		Back	0.772	0.042	0.81		
	Band 2	Front	0.797	0.042	0.84		
		Back	0.75	0.042	0.79		
	Band 25	Front	0.643	0.042	0.69		
		Back	0.761	0.042	0.80		
	Band 7	Front	0.359	0.042	0.40		
		Back	0.579	0.042	0.62		

16.4 SPLSR Evaluation and Analysis

General Note:

- SPLSR = $(SAR_1 + SAR_2)^{1.5} / (min. \text{ separation distance, mm})$. If $SPLSR \leq 0.04$, simultaneously transmission SAR measurement is not necessary

Case No #01 Position	Band	SAR (W/kg)	Gap (cm)	SAR peak location (m)			3D distance (mm)	Pair SAR sum (W/kg)	SPLSR	Simultaneous SAR
				X	Y	Z				
Right Cheek	GSM850	0.403	-	0.0692	-0.262	-0.173	82.1	1.70	0.03	Not required
	WLAN 2.4GHz	1.300	-	0.0336	-0.336	-0.173				

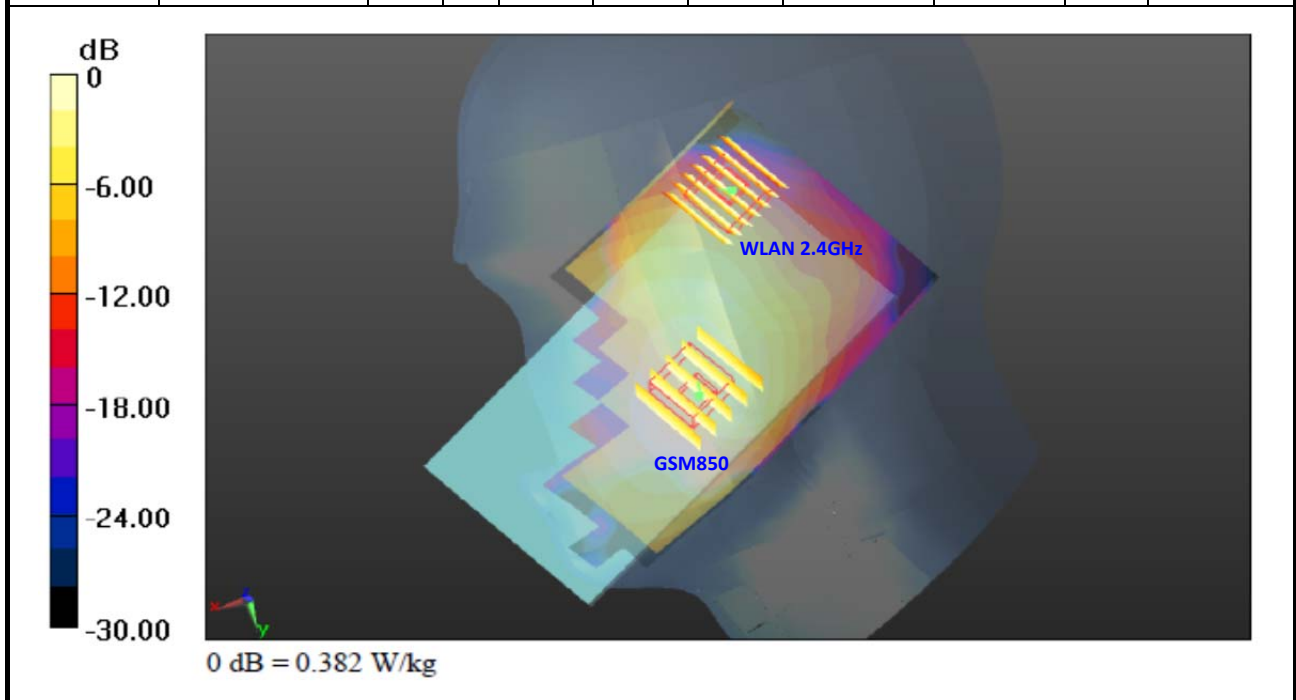

Test Engineer : Luke Lu

17. Uncertainty Assessment

The component of uncertainty may generally be categorized according to the methods used to evaluate them. The evaluation of uncertainty by the statistical analysis of a series of observations is termed a Type A evaluation of uncertainty. The evaluation of uncertainty by means other than the statistical analysis of a series of observation is termed a Type B evaluation of uncertainty. Each component of uncertainty, however evaluated, is represented by an estimated standard deviation, termed standard uncertainty, which is determined by the positive square root of the estimated variance.

A Type A evaluation of standard uncertainty may be based on any valid statistical method for treating data. This includes calculating the standard deviation of the mean of a series of independent observations; using the method of least squares to fit a curve to the data in order to estimate the parameter of the curve and their standard deviations; or carrying out an analysis of variance in order to identify and quantify random effects in certain kinds of measurement.

A type B evaluation of standard uncertainty is typically based on scientific judgment using all of the relevant information available. These may include previous measurement data, experience, and knowledge of the behavior and properties of relevant materials and instruments, manufacture’s specification, data provided in calibration reports and uncertainties assigned to reference data taken from handbooks. Broadly speaking, the uncertainty is either obtained from an outdoor source or obtained from an assumed distribution, such as the normal distribution, rectangular or triangular distributions indicated in table below.

Uncertainty Distributions	Normal	Rectangular	Triangular	U-Shape
Multi-plying Factor ^(a)	1/k ^(b)	1/√3	1/√6	1/√2

(a) standard uncertainty is determined as the product of the multiplying factor and the estimated range of variations in the measured quantity

(b) κ is the coverage factor

Table 17.1. Standard Uncertainty for Assumed Distribution

The combined standard uncertainty of the measurement result represents the estimated standard deviation of the result. It is obtained by combining the individual standard uncertainties of both Type A and Type B evaluation using the usual “root-sum-squares” (RSS) methods of combining standard deviations by taking the positive square root of the estimated variances.

Expanded uncertainty is a measure of uncertainty that defines an interval about the measurement result within which the measured value is confidently believed to lie. It is obtained by multiplying the combined standard uncertainty by a coverage factor. Typically, the coverage factor ranges from 2 to 3. Using a coverage factor allows the true value of a measured quantity to be specified with a defined probability within the specified uncertainty range. For purpose of this document, a coverage factor two is used, which corresponds to confidence interval of about 95 %. The DASY uncertainty Budget is shown in the following tables.

Error Description	Uncertainty Value (±%)	Probability Distribution	Divisor	Ci (1g)	Ci (10g)	Standard Uncertainty (1g)	Standard Uncertainty (10g)
Measurement System							
Probe Calibration	6.0	Normal	1	1	1	± 6.0 %	± 6.0 %
Axial Isotropy	4.7	Rectangular	√3	0.7	0.7	± 1.9 %	± 1.9 %
Hemispherical Isotropy	9.6	Rectangular	√3	0.7	0.7	± 3.9 %	± 3.9 %
Boundary Effects	1.0	Rectangular	√3	1	1	± 0.6 %	± 0.6 %
Linearity	4.7	Rectangular	√3	1	1	± 2.7 %	± 2.7 %
System Detection Limits	1.0	Rectangular	√3	1	1	± 0.6 %	± 0.6 %
Readout Electronics	0.3	Normal	1	1	1	± 0.3 %	± 0.3 %
Response Time	0.8	Rectangular	√3	1	1	± 0.5 %	± 0.5 %
Integration Time	2.6	Rectangular	√3	1	1	± 1.5 %	± 1.5 %
RF Ambient Noise	3.0	Rectangular	√3	1	1	± 1.7 %	± 1.7 %
RF Ambient Reflections	3.0	Rectangular	√3	1	1	± 1.7 %	± 1.7 %
Probe Positioner	0.4	Rectangular	√3	1	1	± 0.2 %	± 0.2 %
Probe Positioning	2.9	Rectangular	√3	1	1	± 1.7 %	± 1.7 %
Max. SAR Eval.	1.0	Rectangular	√3	1	1	± 0.6 %	± 0.6 %
Test Sample Related							
Device Positioning	2.9	Normal	1	1	1	± 2.9 %	± 2.9 %
Device Holder	3.6	Normal	1	1	1	± 3.6 %	± 3.6 %
Power Drift	5.0	Rectangular	√3	1	1	± 2.9 %	± 2.9 %
Phantom and Setup							
Phantom Uncertainty	4.0	Rectangular	√3	1	1	± 2.3 %	± 2.3 %
Liquid Conductivity (Target)	5.0	Rectangular	√3	0.64	0.43	± 1.8 %	± 1.2 %
Liquid Conductivity (Meas.)	2.5	Normal	1	0.64	0.43	± 1.6 %	± 1.1 %
Liquid Permittivity (Target)	5.0	Rectangular	√3	0.6	0.49	± 1.7 %	± 1.4 %
Liquid Permittivity (Meas.)	2.5	Normal	1	0.6	0.49	± 1.5 %	± 1.2 %
Combined Standard Uncertainty						± 11.0 %	± 10.8 %
Coverage Factor for 95 %						K=2	
Expanded Uncertainty						± 22.0 %	± 21.5 %

Table 17.2. Uncertainty Budget for frequency range 300 MHz to 3 GHz

18. References

- [1] FCC 47 CFR Part 2 “Frequency Allocations and Radio Treaty Matters; General Rules and Regulations”
- [2] ANSI/IEEE Std. C95.1-1992, “IEEE Standard for Safety Levels with Respect to Human Exposure to Radio Frequency Electromagnetic Fields, 3 kHz to 300 GHz”, September 1992
- [3] IEEE Std. 1528-2003, “Recommended Practice for Determining the Peak Spatial-Average Specific Absorption Rate (SAR) in the Human Head from Wireless Communications Devices: Measurement Techniques”, December 2003
- [4] SPEAG DASY System Handbook
- [5] FCC KDB 248227 D01 v01r02, “SAR Measurement Procedures for 802.11 a/b/g Transmitters”, May 2007
- [6] FCC KDB 447498 D01 v05r02, “Mobile and Portable Device RF Exposure Procedures and Equipment Authorization Policies”, Feb 2014
- [7] FCC KDB 648474 D04 v01r02, “SAR Evaluation Considerations for Wireless Handsets”, Dec 2013.
- [8] FCC KDB 941225 D01 v02, “SAR Measurement Procedures for 3G Devices – CDMA 2000 / Ev-Do / WCDMA / HSDPA / HSPA”, October 2007
- [9] FCC KDB 941225 D02 v02r02, “SAR Guidance for HSPA, HSPA+, DC-HSDPA and 1x-Advanced”, May 2013.
- [10] FCC KDB 941225 D03 v01, “Recommended SAR Test Reduction Procedures for GSM / GPRS / EDGE”, December 2008
- [11] FCC KDB 941225 D05 v02r03, “SAR Evaluation Considerations for LTE Devices”, Dec 2013
- [12] FCC KDB 941225 D06 v01r01, “SAR Evaluation Procedures for Portable Devices with Wireless Router Capabilities”, May 2013.
- [13] FCC KDB 865664 D01 v01r03, “SAR Measurement Requirements for 100 MHz to 6 GHz”, Feb 2014.
- [14] FCC KDB 865664 D02 v01r01, “RF Exposure Compliance Reporting and Documentation Considerations” May 2013.



Appendix A. Plots of System Performance Check

The plots are shown as follows.

System Check_Head_750MHz_140806

DUT: D750V3-SN:1099

Communication System: UID 0, CW; Frequency: 750 MHz; Duty Cycle: 1:1

Medium: HSL_750_140806 Medium parameters used: $f = 750 \text{ MHz}$; $\sigma = 0.888 \text{ S/m}$; $\epsilon_r = 40.879$; $\rho = 1000 \text{ kg/m}^3$

Ambient Temperature : $23.3 \text{ }^\circ\text{C}$; Liquid Temperature : $22.6 \text{ }^\circ\text{C}$

DASY5 Configuration:

- Probe: EX3DV4 - SN3819; ConvF(10.13, 10.13, 10.13); Calibrated: 2013.11.27;
- Sensor-Surface: 2mm (Mechanical Surface Detection)
- Electronics: DAE3 Sn569; Calibrated: 2013.11.22
- Phantom: SAM2; Type: QD000P40CD; Serial: TP:1671
- Measurement SW: DASY52, Version 52.8 (7); SEMCAD X Version 14.6.10 (7164)

Pin=250mW/Area Scan (61x61x1): Interpolated grid: $dx=15\text{mm}$, $dy=15\text{mm}$

Maximum value of SAR (interpolated) = 2.70 W/kg

Pin=250mW/Zoom Scan (5x5x7)/Cube 0: Measurement grid: $dx=8\text{mm}$, $dy=8\text{mm}$, $dz=5\text{mm}$

Reference Value = 56.222 V/m ; Power Drift = 0.03 dB

Peak SAR (extrapolated) = 3.15 W/kg

SAR(1 g) = 2.15 W/kg ; SAR(10 g) = 1.43 W/kg

Maximum value of SAR (measured) = 2.68 W/kg

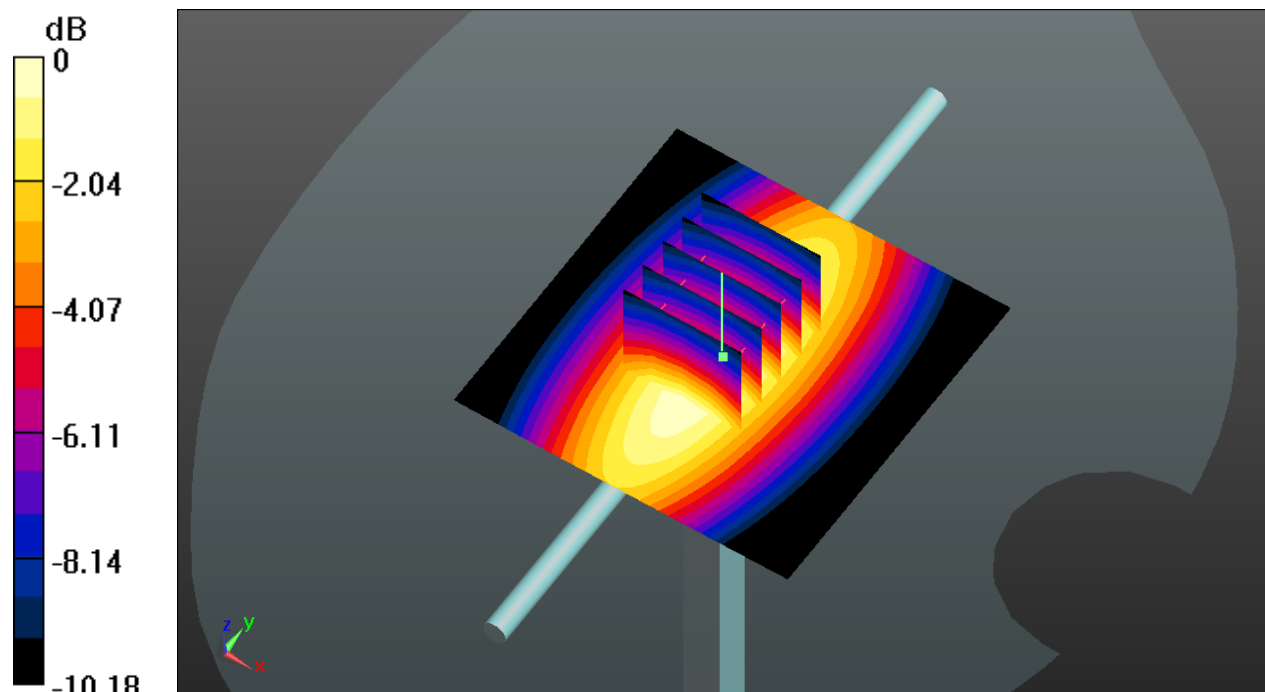

0 dB = 2.68 W/kg

System Check_Head_835MHz_140806

DUT: D835V2-SN:4d091

Communication System: UID 0, CW; Frequency: 835 MHz; Duty Cycle: 1:1

Medium: HSL_835_140806 Medium parameters used: $f = 835 \text{ MHz}$; $\sigma = 0.91 \text{ S/m}$; $\epsilon_r = 42.91$; $\rho = 1000 \text{ kg/m}^3$

Ambient Temperature : $23.3 \text{ }^\circ\text{C}$; Liquid Temperature : $22.7 \text{ }^\circ\text{C}$

DASY5 Configuration:

- Probe: EX3DV4 - SN3819; ConvF(9.68, 9.68, 9.68); Calibrated: 2013.11.27;
- Sensor-Surface: 2mm (Mechanical Surface Detection)
- Electronics: DAE3 Sn569; Calibrated: 2013.11.22
- Phantom: SAM2; Type: QD000P40CD; Serial: TP:1671
- Measurement SW: DASY52, Version 52.8 (7); SEMCAD X Version 14.6.10 (7164)

Pin=250mW/Area Scan (61x61x1): Interpolated grid: $dx=15\text{mm}$, $dy=15\text{mm}$

Maximum value of SAR (interpolated) = 2.90 W/kg

Pin=250mW/Zoom Scan (5x5x7)/Cube 0: Measurement grid: $dx=8\text{mm}$, $dy=8\text{mm}$, $dz=5\text{mm}$

Reference Value = 57.358 V/m ; Power Drift = 0.01 dB

Peak SAR (extrapolated) = 3.38 W/kg

SAR(1 g) = 2.3 W/kg ; SAR(10 g) = 1.51 W/kg

Maximum value of SAR (measured) = 2.90 W/kg

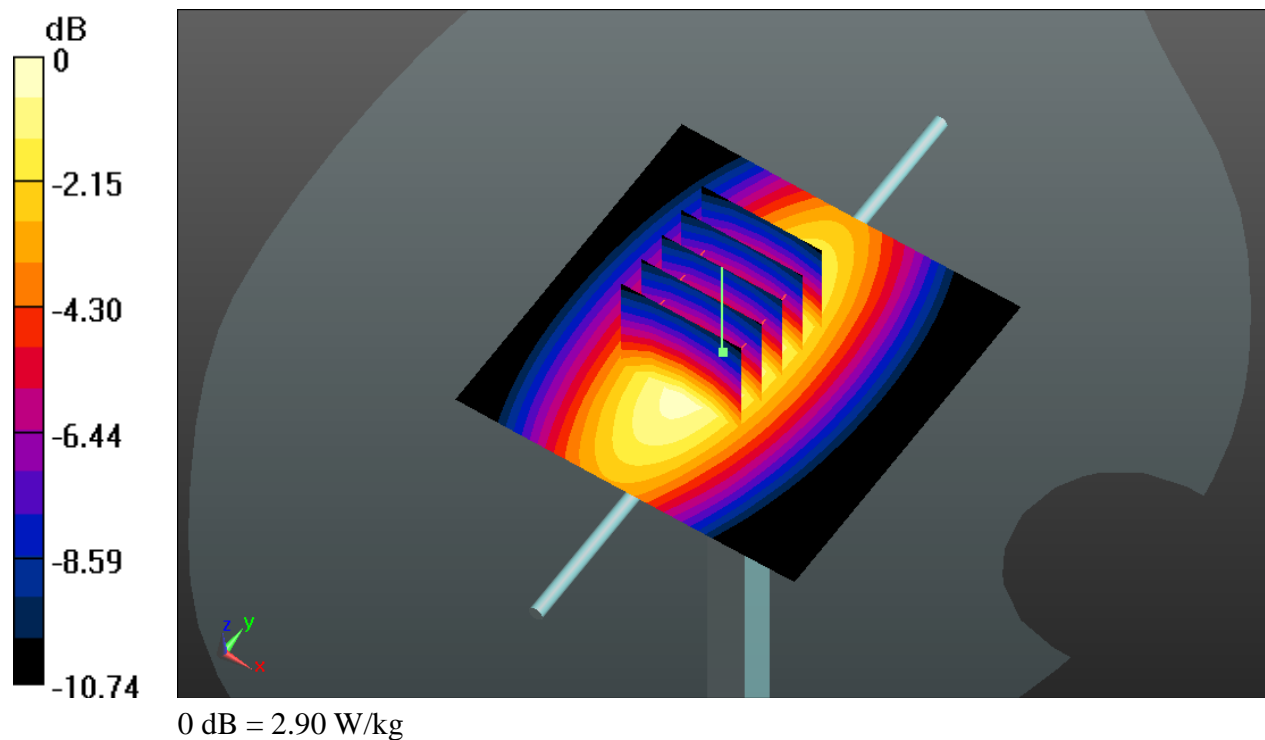

System Check_Head_1750MHz_140816

DUT: D1750V2-SN:1090

Communication System: UID 0, CW; Frequency: 1750 MHz; Duty Cycle: 1:1
 Medium: HSL_1800_140816 Medium parameters used: $f = 1750 \text{ MHz}$; $\sigma = 1.392 \text{ S/m}$; $\epsilon_r = 40.573$;
 $\rho = 1000 \text{ kg/m}^3$
 Ambient Temperature : $23.4 \text{ }^\circ\text{C}$; Liquid Temperature : $22.7 \text{ }^\circ\text{C}$

DASY5 Configuration:

- Probe: EX3DV4 - SN3819; ConvF(8.26, 8.26, 8.26); Calibrated: 2013.11.27;
- Sensor-Surface: 2mm (Mechanical Surface Detection)
- Electronics: DAE3 Sn569; Calibrated: 2013.11.22
- Phantom: SAM2; Type: QD000P40CD; Serial: TP:1671
- Measurement SW: DASY52, Version 52.8 (7); SEMCAD X Version 14.6.10 (7164)

Pin=250mW/Area Scan (61x61x1): Interpolated grid: $dx=15\text{mm}$, $dy=15\text{mm}$

Maximum value of SAR (interpolated) = 13.1 W/kg

Pin=250mW/Zoom Scan (5x5x7)/Cube 0: Measurement grid: $dx=8\text{mm}$, $dy=8\text{mm}$, $dz=5\text{mm}$

Reference Value = 97.352 V/m ; Power Drift = 0.02 dB

Peak SAR (extrapolated) = 16.7 W/kg

SAR(1 g) = 9.13 W/kg ; SAR(10 g) = 4.8 W/kg

Maximum value of SAR (measured) = 12.9 W/kg

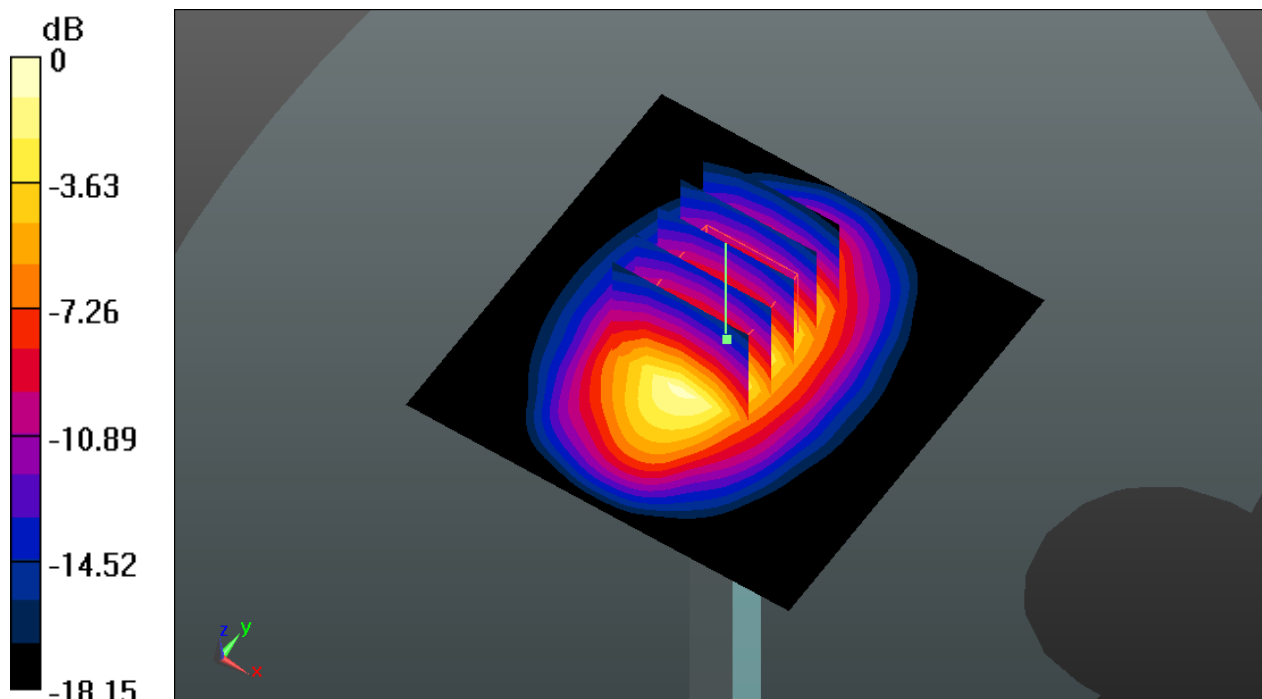

0 dB = 12.9 W/kg

System Check_Head_1750MHz_140827

DUT: F3972X4/UP <32; 2

Communication System: UID 0, CW; Frequency: 1750 MHz; Duty Cycle: 1:1
Medium: HSL_1800_140827 Medium parameters used: $f = 1750$ MHz; $\sigma = 1.38$ S/m; $\epsilon_r = 41.322$; $\rho = 1000$ kg/m³
Ambient Temperature : 23.4 °C; Liquid Temperature : 22.7 °C

DASY5 Configuration:

- Probe: EX3DV4 - SN3819; ConvF(8.26, 8.26, 8.26); Calibrated: 2013.11.27;
- Sensor-Surface: 2mm (Mechanical Surface Detection)
- Electronics: DAE4 Sn910; Calibrated: 2014.07.22
- Phantom: SAM1; Type: QD000P40CD; Serial: TP:1670
- Measurement SW: DASY52, Version 52.8 (7); SEMCAD X Version 14.6.10 (7164)

Pin=250mW/Area Scan (61x61x1): Interpolated grid: dx=15mm, dy=15mm

Maximum value of SAR (interpolated) = 12.8 W/kg

Pin=250mW/Zoom Scan (5x5x7)/Cube 0: Measurement grid: dx=8mm, dy=8mm, dz=5mm

Reference Value = 96.890 V/m; Power Drift = 0.01 dB

Peak SAR (extrapolated) = 16.4 W/kg

SAR(1 g) = 8.94 W/kg; SAR(10 g) = 4.7 W/kg

Maximum value of SAR (measured) = 12.7 W/kg

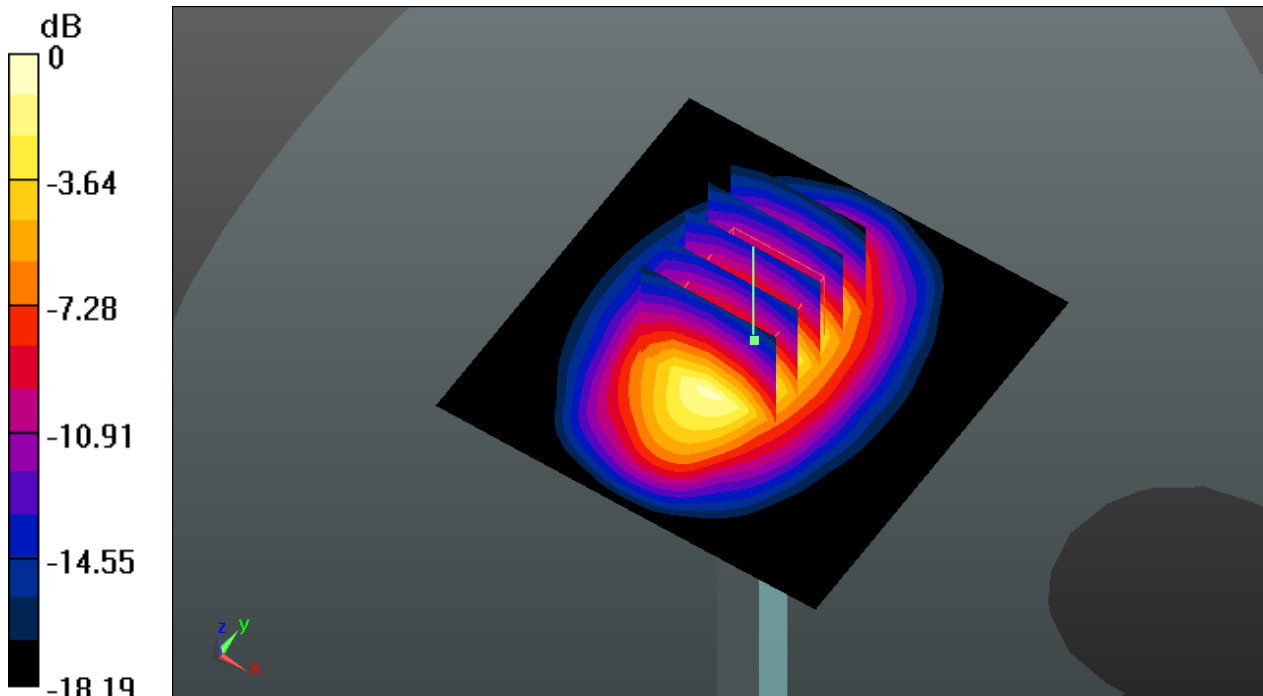

0 dB = 12.7 W/kg

System Check_Head_1900MHz_140807

DUT: D1900V2-SN:5d118

Communication System: UID 0, CW; Frequency: 1900 MHz; Duty Cycle: 1:1

Medium: HSL_1900_140807 Medium parameters used: $f = 1900$ MHz; $\sigma = 1.447$ S/m; $\epsilon_r = 40.017$;

$\rho = 1000$ kg/m³

Ambient Temperature : 23.4 °C; Liquid Temperature : 22.6 °C

DASY5 Configuration:

- Probe: EX3DV4 - SN3819; ConvF(8, 8, 8); Calibrated: 2013.11.27;
- Sensor-Surface: 2mm (Mechanical Surface Detection)
- Electronics: DAE3 Sn569; Calibrated: 2013.11.22
- Phantom: SAM2; Type: QD000P40CD; Serial: TP:1671
- Measurement SW: DASY52, Version 52.8 (7); SEMCAD X Version 14.6.10 (7164)

Pin=250mW/Area Scan (61x61x1): Interpolated grid: dx=15mm, dy=15mm

Maximum value of SAR (interpolated) = 13.9 W/kg

Pin=250mW/Zoom Scan (5x5x7)/Cube 0: Measurement grid: dx=8mm, dy=8mm, dz=5mm

Reference Value = 96.852 V/m; Power Drift = 0.03 dB

Peak SAR (extrapolated) = 17.7 W/kg

SAR(1 g) = 9.62 W/kg; SAR(10 g) = 5.01 W/kg

Maximum value of SAR (measured) = 13.6 W/kg

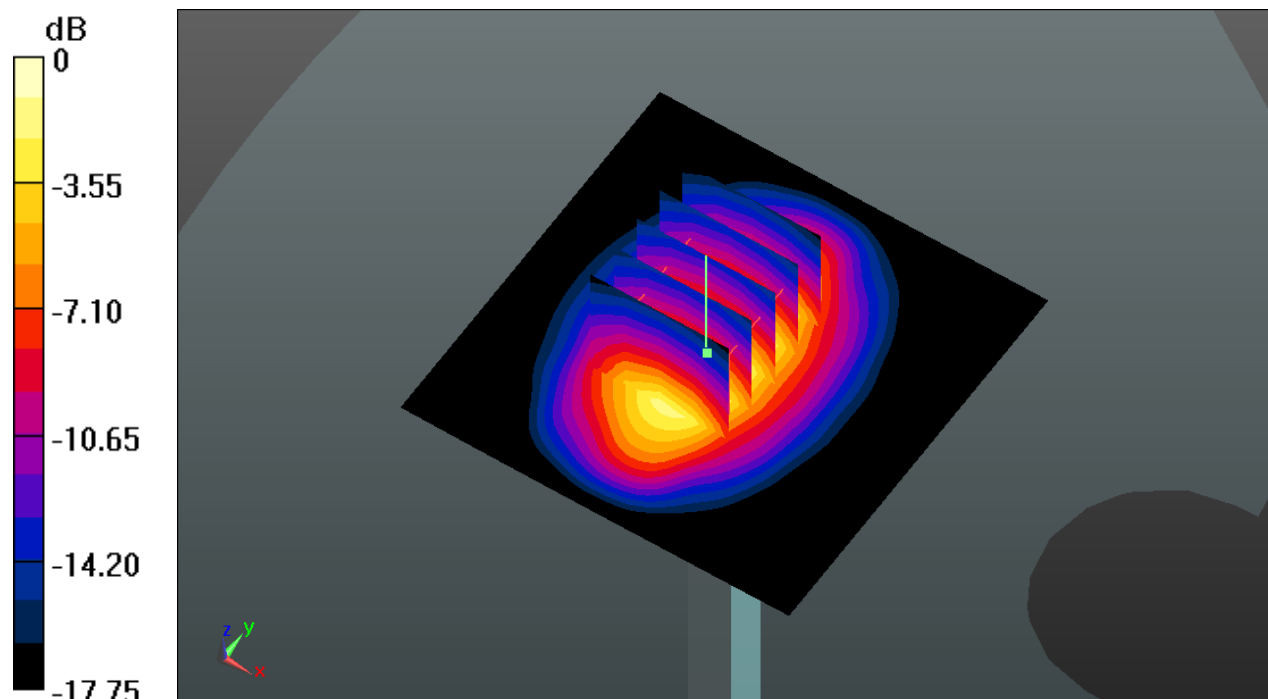

0 dB = 13.6 W/kg

System Check_Head_1900MHz_140816

DUT: D1900V2-SN:5d118

Communication System: UID 0, CW; Frequency: 1900 MHz; Duty Cycle: 1:1
Medium: HSL_1900_140816 Medium parameters used: $f = 1900$ MHz; $\sigma = 1.422$ S/m; $\epsilon_r = 40.315$;
 $\rho = 1000$ kg/m³
Ambient Temperature : 23.5 °C; Liquid Temperature : 22.7 °C

DASY5 Configuration:

- Probe: EX3DV4 - SN3819; ConvF(8, 8, 8); Calibrated: 2013.11.27;
- Sensor-Surface: 2mm (Mechanical Surface Detection)
- Electronics: DAE3 Sn569; Calibrated: 2013.11.22
- Phantom: SAM2; Type: QD000P40CD; Serial: TP:1671
- Measurement SW: DASY52, Version 52.8 (7); SEMCAD X Version 14.6.10 (7164)

Pin=250mW/Area Scan (61x61x1): Interpolated grid: dx=15mm, dy=15mm

Maximum value of SAR (interpolated) = 13.6 W/kg

Pin=250mW/Zoom Scan (5x5x7)/Cube 0: Measurement grid: dx=8mm, dy=8mm, dz=5mm

Reference Value = 96.852 V/m; Power Drift = 0.03 dB

Peak SAR (extrapolated) = 17.4 W/kg

SAR(1 g) = 9.46 W/kg; SAR(10 g) = 4.92 W/kg

Maximum value of SAR (measured) = 13.4 W/kg

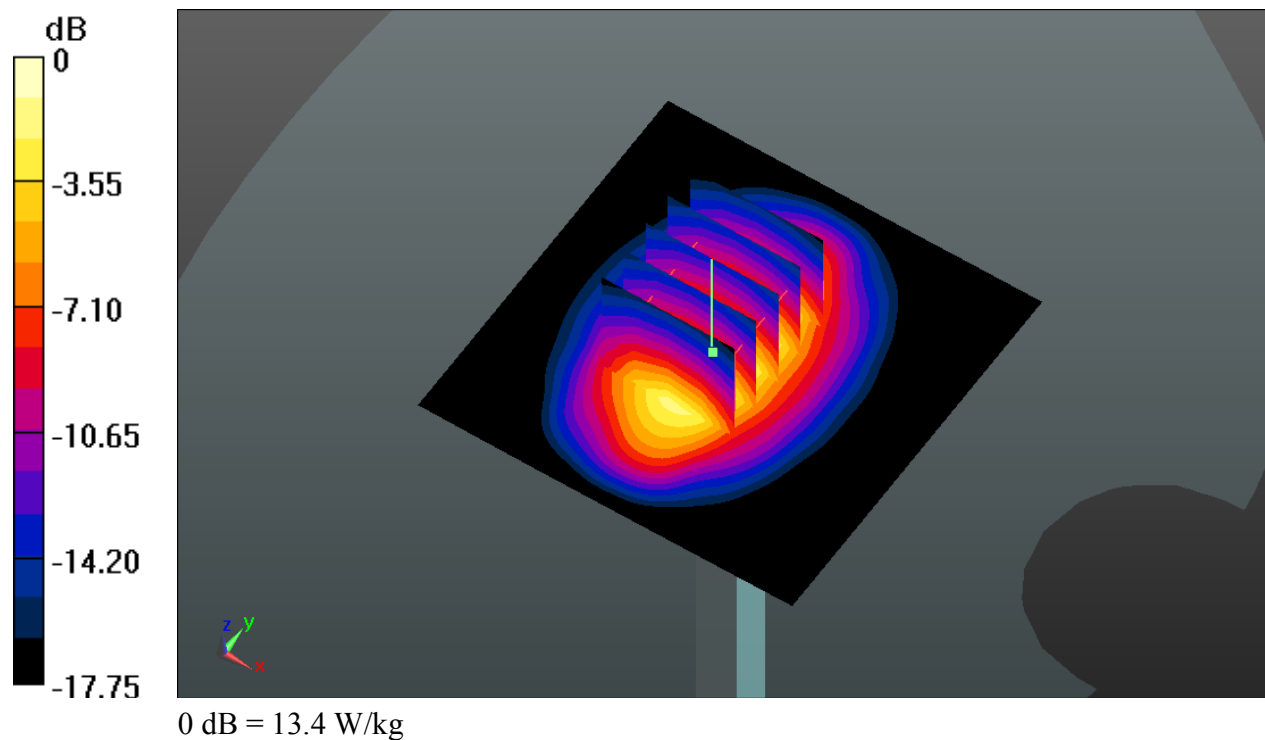

System Check_Head_2450MHz_140817

DUT: D2450V2-SN:908

Communication System: UID 0, CW; Frequency: 2450 MHz; Duty Cycle: 1:1
Medium: HSL_2450_140817 Medium parameters used: $f = 2450$ MHz; $\sigma = 1.834$ S/m; $\epsilon_r = 39.654$;
 $\rho = 1000$ kg/m³
Ambient Temperature : 23.3 °C; Liquid Temperature : 22.7 °C

DASY5 Configuration:

- Probe: EX3DV4 - SN3819; ConvF(7.22, 7.22, 7.22); Calibrated: 2013.11.27;
- Sensor-Surface: 2mm (Mechanical Surface Detection)
- Electronics: DAE3 Sn569; Calibrated: 2013.11.22
- Phantom: SAM1; Type: QD000P40CD; Serial: TP:1670
- Measurement SW: DASY52, Version 52.8 (7); SEMCAD X Version 14.6.10 (7164)

Pin=250mW/Area Scan (81x81x1): Interpolated grid: dx=12mm, dy=12mm
Maximum value of SAR (interpolated) = 18.7 W/kg

Pin=250mW/Zoom Scan (7x7x7)/Cube 0: Measurement grid: dx=5mm, dy=5mm, dz=5mm
Reference Value = 85.758 V/m; Power Drift = -0.02 dB
Peak SAR (extrapolated) = 24.9 W/kg
SAR(1 g) = 12.2 W/kg; SAR(10 g) = 5.64 W/kg
Maximum value of SAR (measured) = 18.5 W/kg

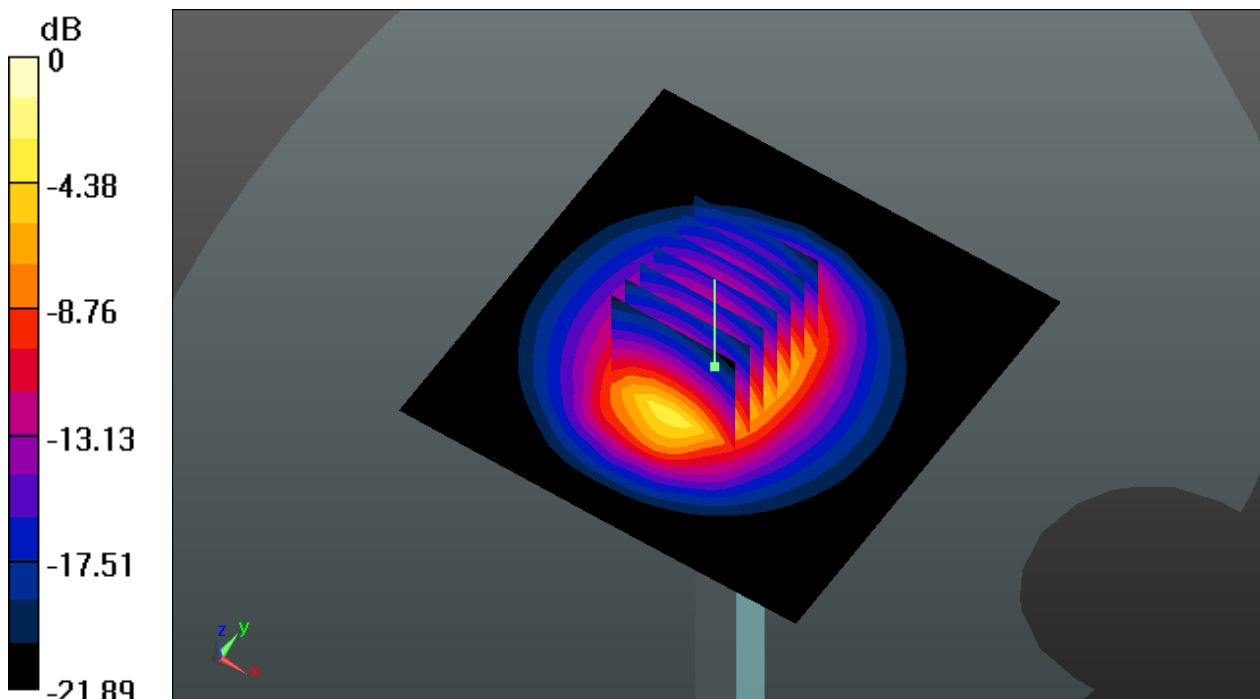

0 dB = 18.5 W/kg

System Check_Head_2600MHz_140815

DUT: D2600V2-SN:1061

Communication System: UID 0, CW; Frequency: 2600 MHz; Duty Cycle: 1:1
Medium: HSL_2600_140815 Medium parameters used: $f = 2600$ MHz; $\sigma = 2.055$ S/m; $\epsilon_r = 38.316$;
 $\rho = 1000$ kg/m³
Ambient Temperature : 23.3 °C; Liquid Temperature : 22.7 °C

DASY5 Configuration:

- Probe: EX3DV4 - SN3819; ConvF(7.06, 7.06, 7.06); Calibrated: 2013.11.27;
- Sensor-Surface: 2mm (Mechanical Surface Detection)
- Electronics: DAE3 Sn569; Calibrated: 2013.11.22
- Phantom: SAM1; Type: QD000P40CD; Serial: TP:1670
- Measurement SW: DASY52, Version 52.8 (7); SEMCAD X Version 14.6.10 (7164)

Pin=250mW/Area Scan (61x61x1): Interpolated grid: dx=12mm, dy=12mm

Maximum value of SAR (interpolated) = 23.1 W/kg

Pin=250mW/Zoom Scan (7x7x7)/Cube 0: Measurement grid: dx=5mm, dy=5mm, dz=5mm

Reference Value = 104.7 V/m; Power Drift = 0.02 dB

Peak SAR (extrapolated) = 31.0 W/kg

SAR(1 g) = 13.6 W/kg; SAR(10 g) = 6 W/kg

Maximum value of SAR (measured) = 21.4 W/kg

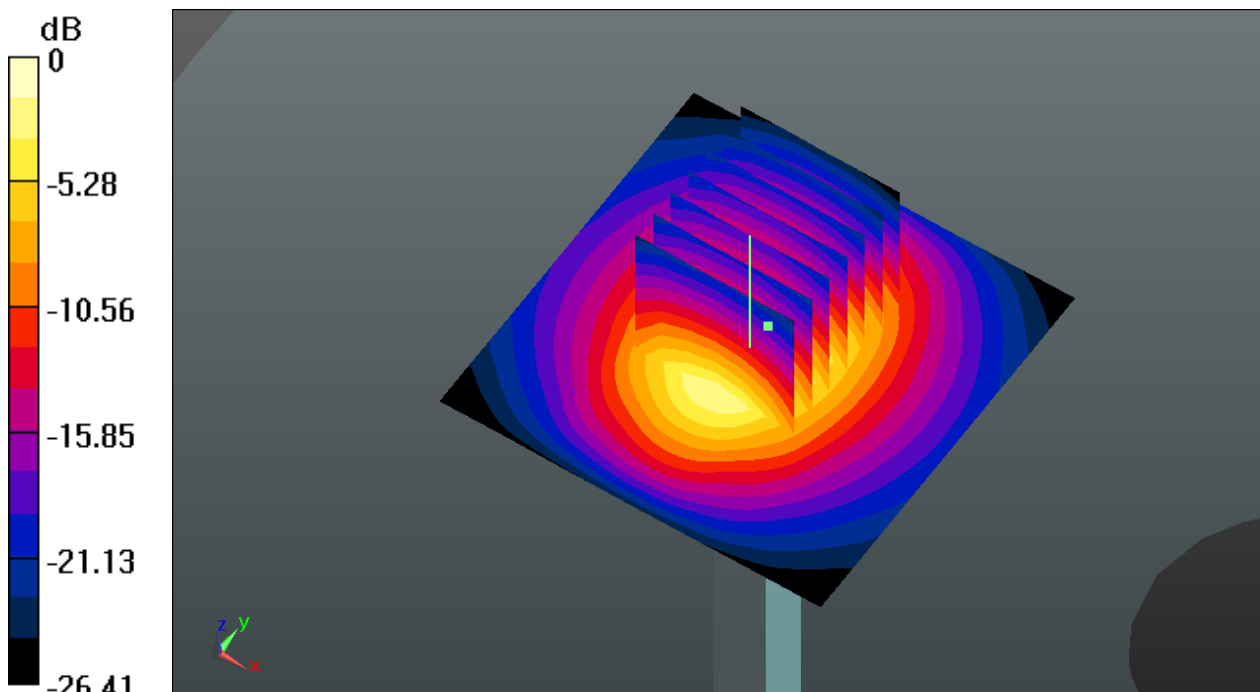

0 dB = 21.4 W/kg

System Check_Body_750MHz_140805

DUT: D750V3-SN:1099

Communication System: UID 0, CW; Frequency: 750 MHz; Duty Cycle: 1:1
Medium: MSL_750_140805 Medium parameters used: $f = 750$ MHz; $\sigma = 0.963$ S/m; $\epsilon_r = 54.231$; $\rho = 1000$ kg/m³
Ambient Temperature : 23.2 °C; Liquid Temperature : 22.6 °C

DASY5 Configuration:

- Probe: EX3DV4 - SN3819; ConvF(9.71, 9.71, 9.71); Calibrated: 2013.11.27;
- Sensor-Surface: 2mm (Mechanical Surface Detection)
- Electronics: DAE3 Sn569; Calibrated: 2013.11.22
- Phantom: SAM2; Type: QD000P40CD; Serial: TP:1671
- Measurement SW: DASY52, Version 52.8 (7); SEMCAD X Version 14.6.10 (7164)

Pin=250mW/Area Scan (61x61x1): Interpolated grid: dx=15mm, dy=15mm

Maximum value of SAR (interpolated) = 2.79 W/kg

Pin=250mW/Zoom Scan (5x5x7)/Cube 0: Measurement grid: dx=8mm, dy=8mm, dz=5mm

Reference Value = 49.803 V/m; Power Drift = 0.03 dB

Peak SAR (extrapolated) = 3.24 W/kg

SAR(1 g) = 2.25 W/kg; SAR(10 g) = 1.51 W/kg

Maximum value of SAR (measured) = 2.80 W/kg

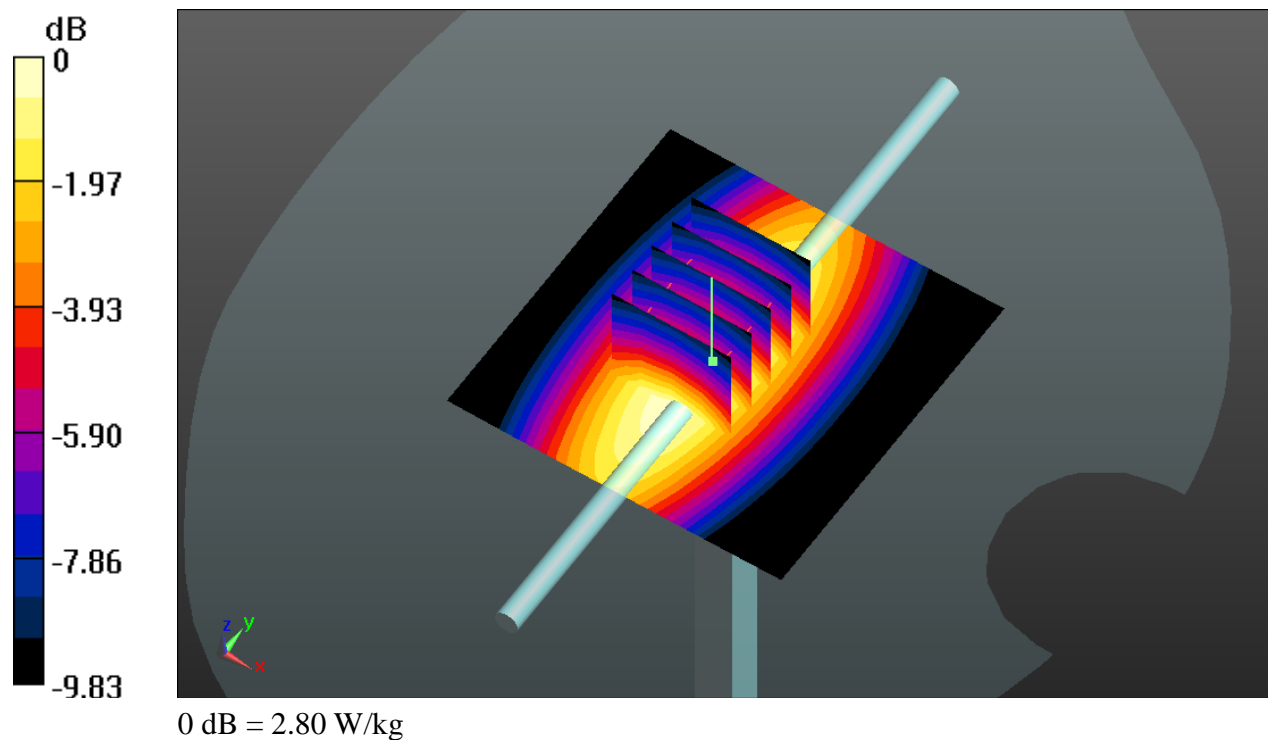

System Check_Body_835MHz_140805

DUT: D835V2-SN:4d091

Communication System: UID 0, CW; Frequency: 835 MHz; Duty Cycle: 1:1
Medium: MSL_835_140805 Medium parameters used: $f = 835 \text{ MHz}$; $\sigma = 0.977 \text{ S/m}$; $\epsilon_r = 54.395$; $\rho = 1000 \text{ kg/m}^3$
Ambient Temperature : $23.2 \text{ }^\circ\text{C}$; Liquid Temperature : $22.6 \text{ }^\circ\text{C}$

DASY5 Configuration:

- Probe: EX3DV4 - SN3819; ConvF(9.54, 9.54, 9.54); Calibrated: 2013.11.27;
- Sensor-Surface: 2mm (Mechanical Surface Detection)
- Electronics: DAE3 Sn569; Calibrated: 2013.11.22
- Phantom: SAM2; Type: QD000P40CD; Serial: TP:1671
- Measurement SW: DASY52, Version 52.8 (7); SEMCAD X Version 14.6.10 (7164)

Pin=250mW/Area Scan (61x61x1): Interpolated grid: $dx=15\text{mm}$, $dy=15\text{mm}$

Maximum value of SAR (interpolated) = 2.39 W/kg

Pin=250mW/Zoom Scan (5x5x7)/Cube 0: Measurement grid: $dx=8\text{mm}$, $dy=8\text{mm}$, $dz=5\text{mm}$

Reference Value = 49.686 V/m ; Power Drift = 0.02 dB

Peak SAR (extrapolated) = 3.18 W/kg

SAR(1 g) = 2.22 W/kg ; SAR(10 g) = 1.47 W/kg

Maximum value of SAR (measured) = 2.38 W/kg

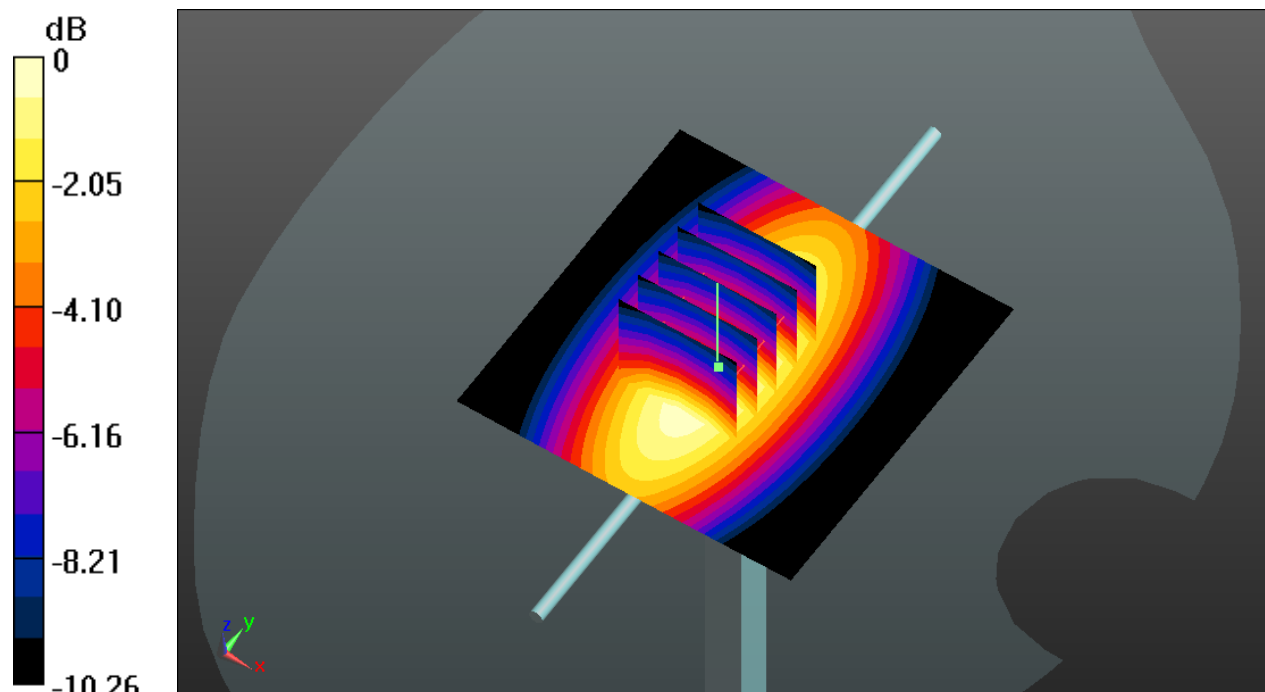

0 dB = 2.38 W/kg

System Check_Body_1750MHz_140803

DUT: D1750V2-SN:1090

Communication System: UID 0, CW; Frequency: 1750 MHz; Duty Cycle: 1:1

Medium: MSL_1800_140803 Medium parameters used: $f = 1750$ MHz; $\sigma = 1.528$ S/m; $\epsilon_r = 52.031$;
 $\rho = 1000$ kg/m³

Ambient Temperature : 23.4 °C; Liquid Temperature : 22.7 °C

DASY5 Configuration:

- Probe: EX3DV4 - SN3819; ConvF(8.01, 8.01, 8.01); Calibrated: 2013.11.27;
- Sensor-Surface: 2mm (Mechanical Surface Detection)
- Electronics: DAE3 Sn569; Calibrated: 2013.11.22
- Phantom: SAM2; Type: QD000P40CD; Serial: TP:1671
- Measurement SW: DASY52, Version 52.8 (7); SEMCAD X Version 14.6.10 (7164)

Pin=250mW/Area Scan (61x61x1): Interpolated grid: dx=15mm, dy=15mm

Maximum value of SAR (interpolated) = 13.7 W/kg

Pin=250mW/Zoom Scan (5x5x7)/Cube 0: Measurement grid: dx=8mm, dy=8mm, dz=5mm

Reference Value = 95.361 V/m; Power Drift = 0.02 dB

Peak SAR (extrapolated) = 17.1 W/kg

SAR(1 g) = 9.69 W/kg; SAR(10 g) = 5.18 W/kg

Maximum value of SAR (measured) = 13.5 W/kg

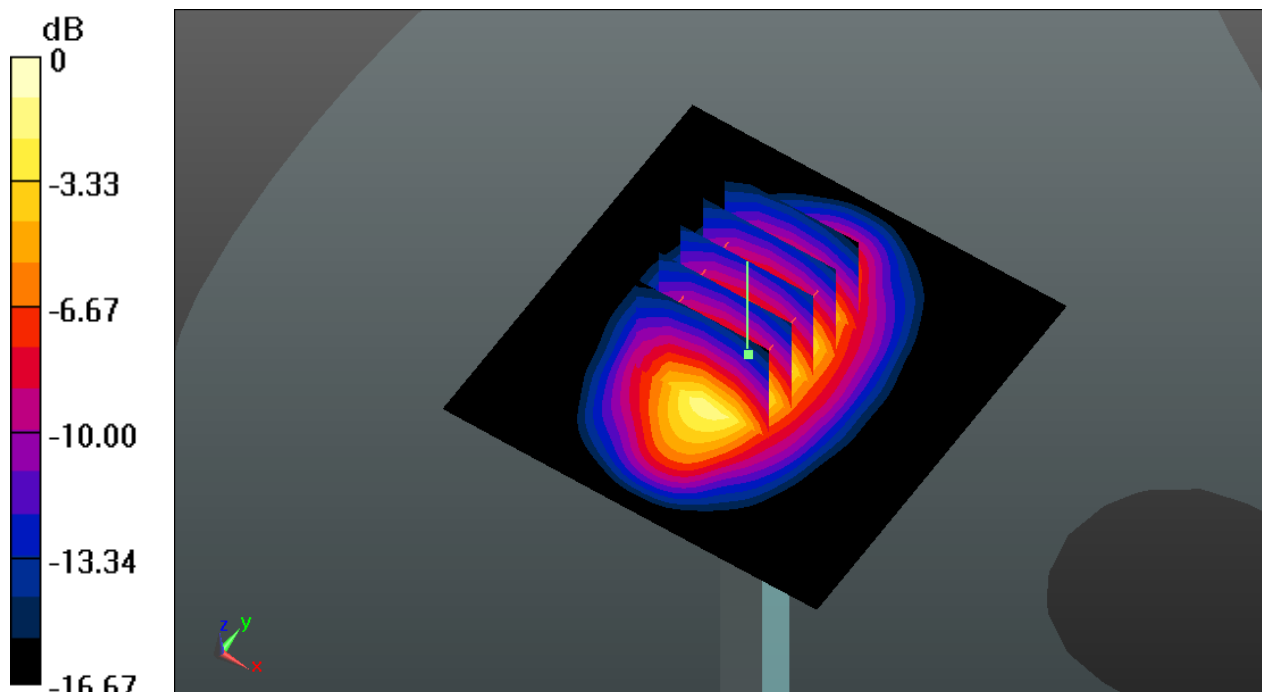

0 dB = 13.5 W/kg

System Check_Body_1750MHz_140827

DUT: D1750V2-SN:1090

Communication System: UID 0, CW; Frequency: 1750 MHz; Duty Cycle: 1:1

Medium: MSL_1800_140827 Medium parameters used: $f = 1750$ MHz; $\sigma = 1.526$ S/m; $\epsilon_r = 52.619$;
 $\rho = 1000$ kg/m³

Ambient Temperature : 23.4 °C; Liquid Temperature : 22.6 °C

DASY5 Configuration:

- Probe: EX3DV4 - SN3819; ConvF(8.01, 8.01, 8.01); Calibrated: 2013.11.27;
- Sensor-Surface: 2mm (Mechanical Surface Detection)
- Electronics: DAE4 Sn910; Calibrated: 2014.07.22
- Phantom: SAM2; Type: QD000P40CD; Serial: TP:1671
- Measurement SW: DASY52, Version 52.8 (7); SEMCAD X Version 14.6.10 (7164)

Pin=250mW/Area Scan (61x61x1): Interpolated grid: dx=15mm, dy=15mm

Maximum value of SAR (interpolated) = 13.5 W/kg

Pin=250mW/Zoom Scan (5x5x7)/Cube 0: Measurement grid: dx=8mm, dy=8mm, dz=5mm

Reference Value = 94.858 V/m; Power Drift = 0.02 dB

Peak SAR (extrapolated) = 16.8 W/kg

SAR(1 g) = 9.57 W/kg; SAR(10 g) = 5.11 W/kg

Maximum value of SAR (measured) = 13.4 W/kg

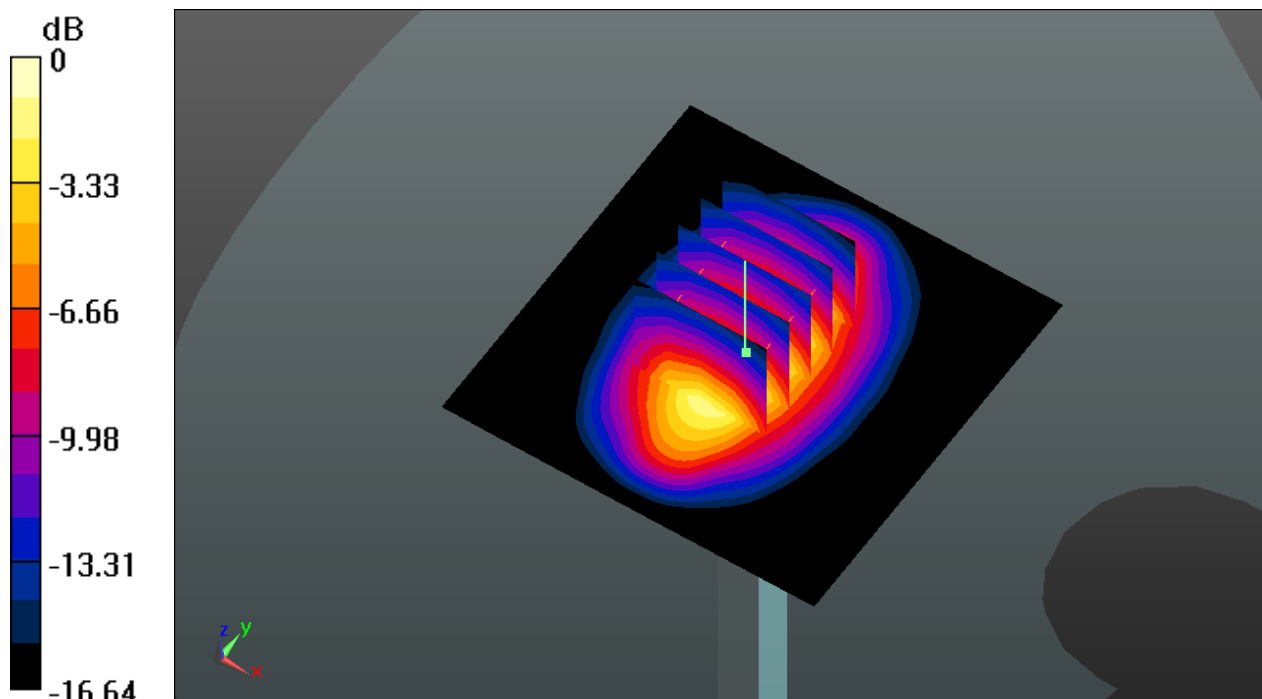

0 dB = 13.4 W/kg

System Check_Body_1900MHz_140803

DUT: D1900V2-SN:5d118

Communication System: UID 0, CW; Frequency: 1900 MHz; Duty Cycle: 1:1
 Medium: MSL_1900_140803 Medium parameters used: $f = 1900$ MHz; $\sigma = 1.581$ S/m; $\epsilon_r = 54.208$;
 $\rho = 1000$ kg/m³
 Ambient Temperature : 23.2 °C; Liquid Temperature : 22.7 °C

DASY5 Configuration:

- Probe: EX3DV4 - SN3819; ConvF(7.55, 7.55, 7.55); Calibrated: 2013.11.27;
- Sensor-Surface: 2mm (Mechanical Surface Detection)
- Electronics: DAE3 Sn569; Calibrated: 2013.11.22
- Phantom: SAM2; Type: QD000P40CD; Serial: TP:1671
- Measurement SW: DASY52, Version 52.8 (7); SEMCAD X Version 14.6.10 (7164)

Pin=250mW/Area Scan (61x61x1): Interpolated grid: dx=15mm, dy=15mm

Maximum value of SAR (interpolated) = 15.0 W/kg

Pin=250mW/Zoom Scan (5x5x7)/Cube 0: Measurement grid: dx=8mm, dy=8mm, dz=5mm

Reference Value = 85.635 V/m; Power Drift = -0.00 dB

Peak SAR (extrapolated) = 18.9 W/kg

SAR(1 g) = 10.7 W/kg; SAR(10 g) = 5.61 W/kg

Maximum value of SAR (measured) = 15.0 W/kg

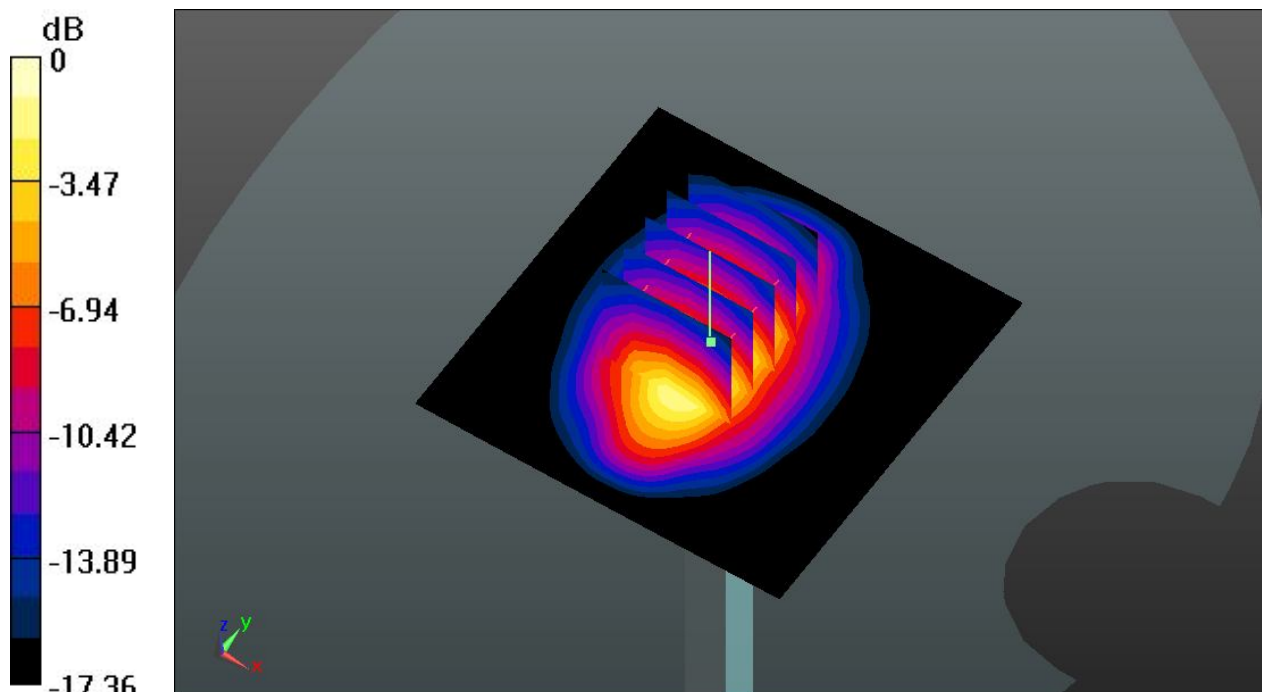

0 dB = 15.0 W/kg

System Check_Body_1900MHz_140813

DUT: D1900V2-SN:5d118

Communication System: UID 0, CW; Frequency: 1900 MHz; Duty Cycle: 1:1

Medium: MSL_1900_140813 Medium parameters used: $f = 1900$ MHz; $\sigma = 1.545$ S/m; $\epsilon_r = 53.535$;
 $\rho = 1000$ kg/m³

Ambient Temperature : 23.2 °C; Liquid Temperature : 22.6 °C

DASY5 Configuration:

- Probe: EX3DV4 - SN3819; ConvF(7.55, 7.55, 7.55); Calibrated: 2013.11.27;
- Sensor-Surface: 2mm (Mechanical Surface Detection)
- Electronics: DAE3 Sn569; Calibrated: 2013.11.22
- Phantom: SAM2; Type: QD000P40CD; Serial: TP:1671
- Measurement SW: DASY52, Version 52.8 (7); SEMCAD X Version 14.6.10 (7164)

Pin=250mW/Area Scan (61x61x1): Interpolated grid: dx=15mm, dy=15mm

Maximum value of SAR (interpolated) = 14.8 W/kg

Pin=250mW/Zoom Scan (5x5x7)/Cube 0: Measurement grid: dx=8mm, dy=8mm, dz=5mm

Reference Value = 86.373 V/m; Power Drift = 0.04 dB

Peak SAR (extrapolated) = 18.8 W/kg

SAR(1 g) = 10.4 W/kg; SAR(10 g) = 5.39 W/kg

Maximum value of SAR (measured) = 14.9 W/kg

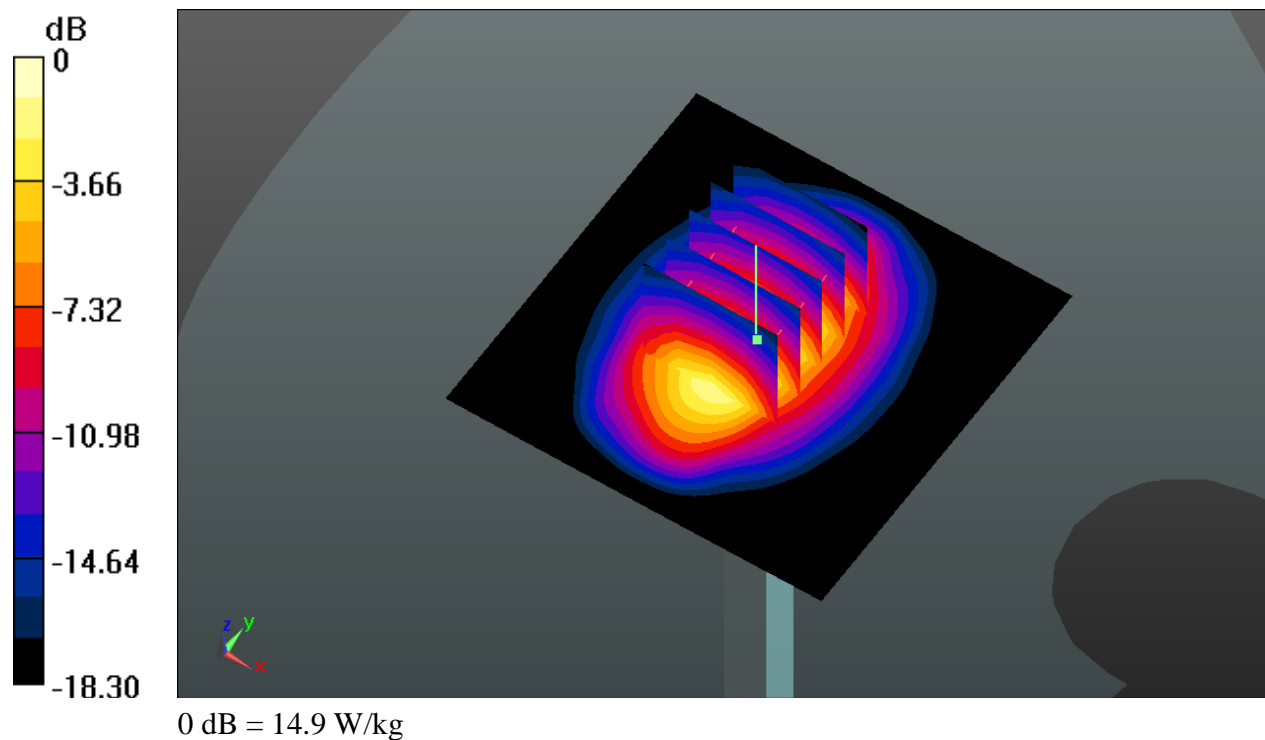

System Check_Body_2450MHz_140817

DUT: D2450V2-SN:908

Communication System: UID 0, CW; Frequency: 2450 MHz; Duty Cycle: 1:1
Medium: MSL_2450_140817 Medium parameters used: $f = 2450$ MHz; $\sigma = 2.013$ S/m; $\epsilon_r = 51.474$;
 $\rho = 1000$ kg/m³
Ambient Temperature : 23.3 °C; Liquid Temperature : 22.6 °C

DASY5 Configuration:

- Probe: EX3DV4 - SN3819; ConvF(7.07, 7.07, 7.07); Calibrated: 2013.11.27;
- Sensor-Surface: 2mm (Mechanical Surface Detection)
- Electronics: DAE3 Sn569; Calibrated: 2013.11.22
- Phantom: SAM1; Type: QD000P40CD; Serial: TP:1670
- Measurement SW: DASY52, Version 52.8 (7); SEMCAD X Version 14.6.10 (7164)

Pin=250mW/Area Scan (81x81x1): Interpolated grid: dx=12mm, dy=12mm

Maximum value of SAR (interpolated) = 20.5 W/kg

Pin=250mW/Zoom Scan (7x7x7)/Cube 0: Measurement grid: dx=5mm, dy=5mm, dz=5mm

Reference Value = 86.646 V/m; Power Drift = 0.02 dB

Peak SAR (extrapolated) = 27.4 W/kg

SAR(1 g) = 13.4 W/kg; SAR(10 g) = 6.17 W/kg

Maximum value of SAR (measured) = 20.4 W/kg

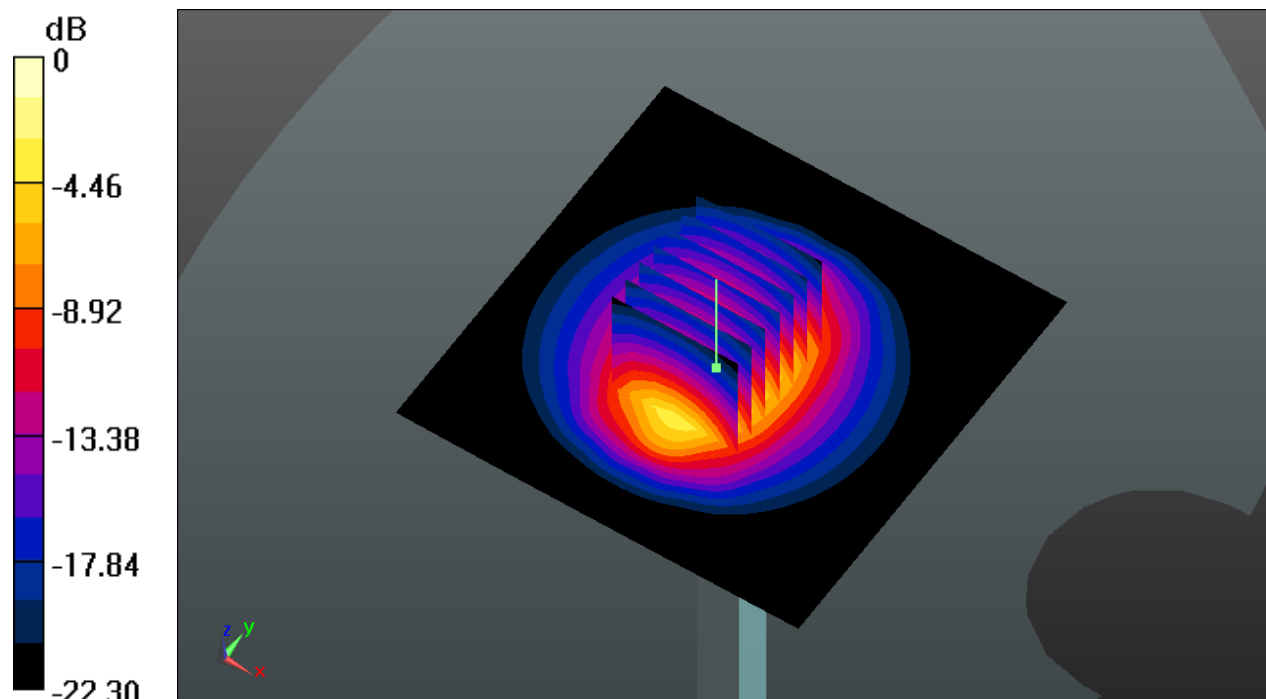

0 dB = 20.4 W/kg

System Check_Body_2600MHz_140804

DUT: D2600V2-SN:1061

Communication System: UID 0, CW (0); Frequency: 2600 MHz; Duty Cycle: 1:1
Medium: MSL_2600_140804 Medium parameters used: $f = 2600$ MHz; $\sigma = 2.209$ S/m; $\epsilon_r = 51.123$;
 $\rho = 1000$ kg/m³
Ambient Temperature : 23.5 °C; Liquid Temperature : 22.8 °C

DASY5 Configuration:

- Probe: EX3DV4 - SN3819; ConvF(6.79, 6.79, 6.79); Calibrated: 2013.11.27;
- Sensor-Surface: 2mm (Mechanical Surface Detection)
- Electronics: DAE3 Sn569; Calibrated: 2013.11.22
- Phantom: SAM2; Type: QD000P40CD; Serial: TP:1671
- Measurement SW: DASY52, Version 52.8 (7); SEMCAD X Version 14.6.10 (7164)

Pin=250mW/Area Scan (61x61x1): Interpolated grid: dx=12mm, dy=12mm

Maximum value of SAR (interpolated) = 21.4 W/kg

Pin=250mW/Zoom Scan (7x7x7)/Cube 0: Measurement grid: dx=5mm, dy=5mm, dz=5mm

Reference Value = 84.618 V/m; Power Drift = -0.06 dB

Peak SAR (extrapolated) = 28.0 W/kg

SAR(1 g) = 13.3 W/kg; SAR(10 g) = 5.97 W/kg

Maximum value of SAR (measured) = 20.6 W/kg

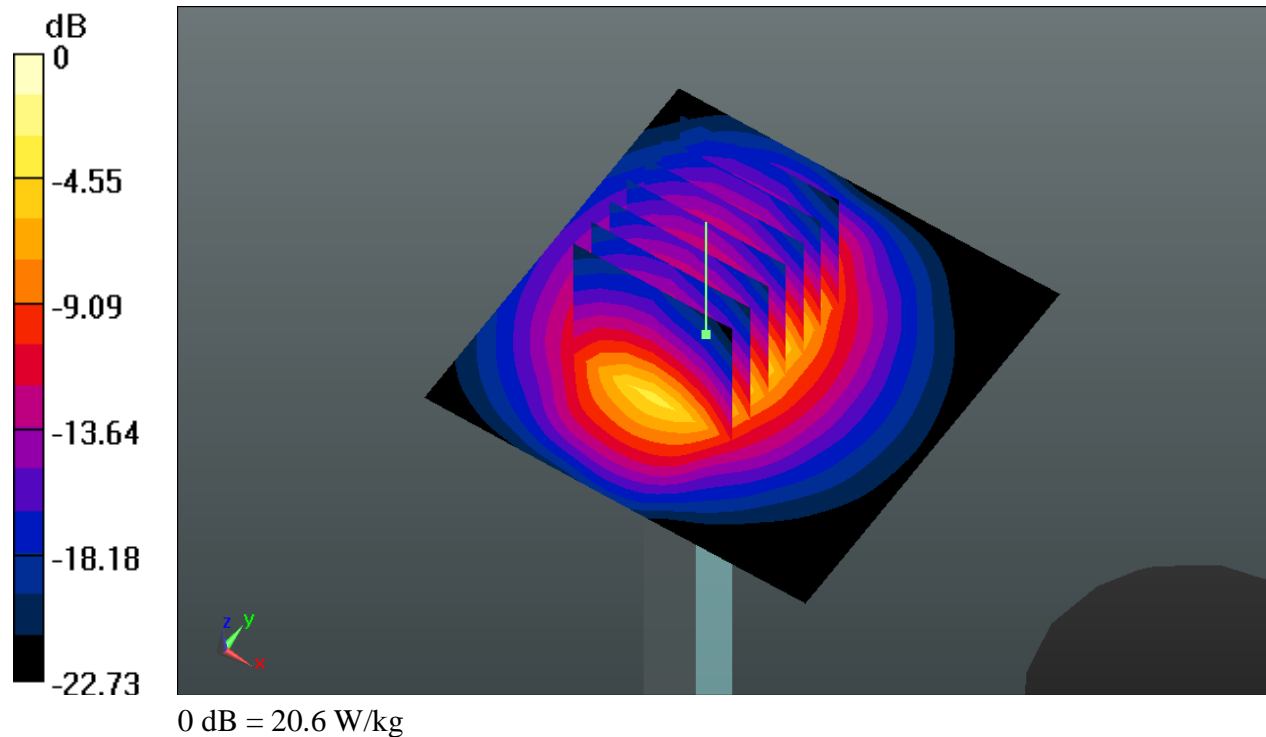



Appendix B. Plots of High SAR Measurement

The plots are shown as follows.

01_GSM850_GPRS(2 Tx slots)_Right Cheek_Ch189

Communication System: UID 0, GPRS/EDGE10 (0); Frequency: 836.4 MHz; Duty Cycle: 1:4.15
Medium: HSL_835_140806 Medium parameters used: $f = 836.4$ MHz; $\sigma = 0.912$ S/m; $\epsilon_r = 42.893$;
 $\rho = 1000$ kg/m³
Ambient Temperature : 23.3 °C; Liquid Temperature : 22.7 °C

DASY5 Configuration:

- Probe: EX3DV4 - SN3819; ConvF(9.68, 9.68, 9.68); Calibrated: 2013.11.27;
- Sensor-Surface: 2mm (Mechanical Surface Detection)
- Electronics: DAE3 Sn569; Calibrated: 2013.11.22
- Phantom: SAM2; Type: QD000P40CD; Serial: TP:1671
- Measurement SW: DASY52, Version 52.8 (7); SEMCAD X Version 14.6.10 (7164)

Ch189/Area Scan (71x131x1): Interpolated grid: dx=15mm, dy=15mm

Maximum value of SAR (interpolated) = 0.393 W/kg

Ch189/Zoom Scan (5x5x7)/Cube 0: Measurement grid: dx=8mm, dy=8mm, dz=5mm

Reference Value = 1.283 V/m; Power Drift = 0.04 dB

Peak SAR (extrapolated) = 0.407 W/kg

SAR(1 g) = 0.342 W/kg; SAR(10 g) = 0.267 W/kg

Maximum value of SAR (measured) = 0.382 W/kg

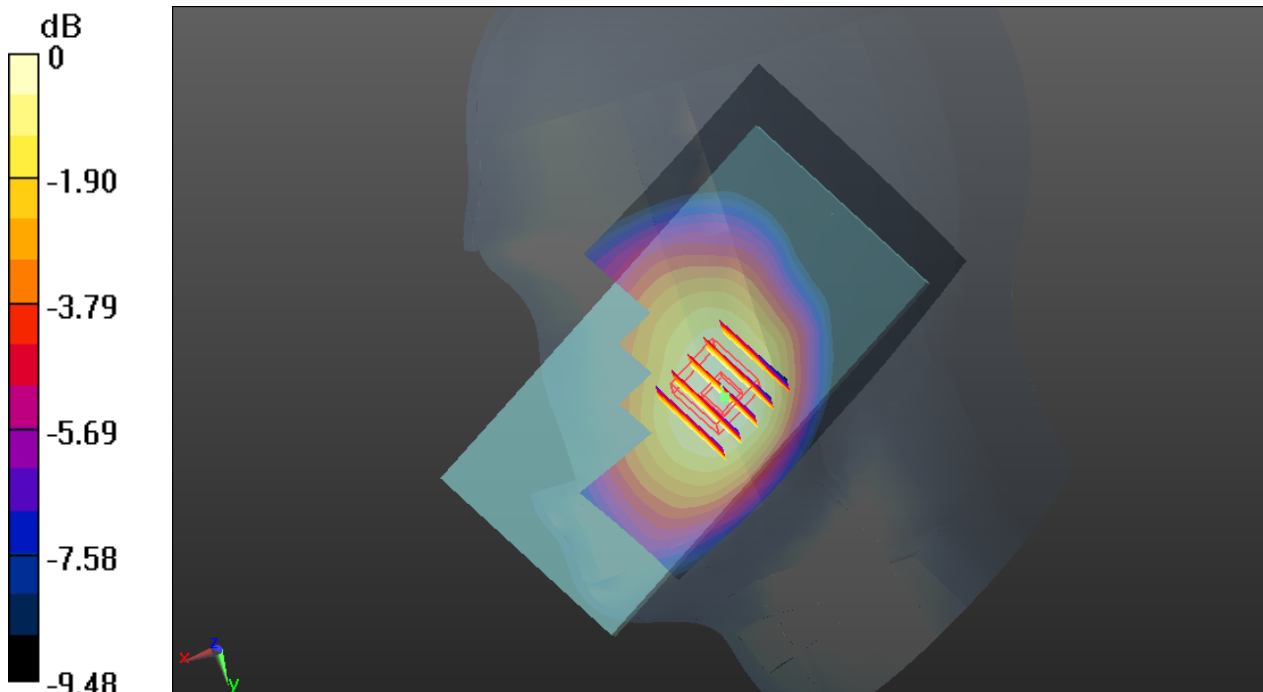

0 dB = 0.382 W/kg

02_GSM1900_GPRS(2 Tx slots)_Left Cheek_Ch661

Communication System: UID 0, GPRS/EDGE10 (0); Frequency: 1880 MHz; Duty Cycle: 1:4.15
Medium: HSL_1900_140816 Medium parameters used: $f = 1880$ MHz; $\sigma = 1.402$ S/m; $\epsilon_r = 40.407$;
 $\rho = 1000$ kg/m³
Ambient Temperature : 23.5 °C; Liquid Temperature : 22.7 °C

DASY5 Configuration:

- Probe: EX3DV4 - SN3819; ConvF(8, 8, 8); Calibrated: 2013.11.27;
- Sensor-Surface: 2mm (Mechanical Surface Detection)
- Electronics: DAE3 Sn569; Calibrated: 2013.11.22
- Phantom: SAM2; Type: QD000P40CD; Serial: TP:1671
- Measurement SW: DASY52, Version 52.8 (7); SEMCAD X Version 14.6.10 (7164)

Ch661/Area Scan (71x131x1): Interpolated grid: dx=15mm, dy=15mm

Maximum value of SAR (interpolated) = 0.311 W/kg

Ch661/Zoom Scan (5x5x7)/Cube 0: Measurement grid: dx=8mm, dy=8mm, dz=5mm

Reference Value = 1.461 V/m; Power Drift = -0.05 dB

Peak SAR (extrapolated) = 0.394 W/kg

SAR(1 g) = 0.268 W/kg; SAR(10 g) = 0.172 W/kg

Maximum value of SAR (measured) = 0.331 W/kg

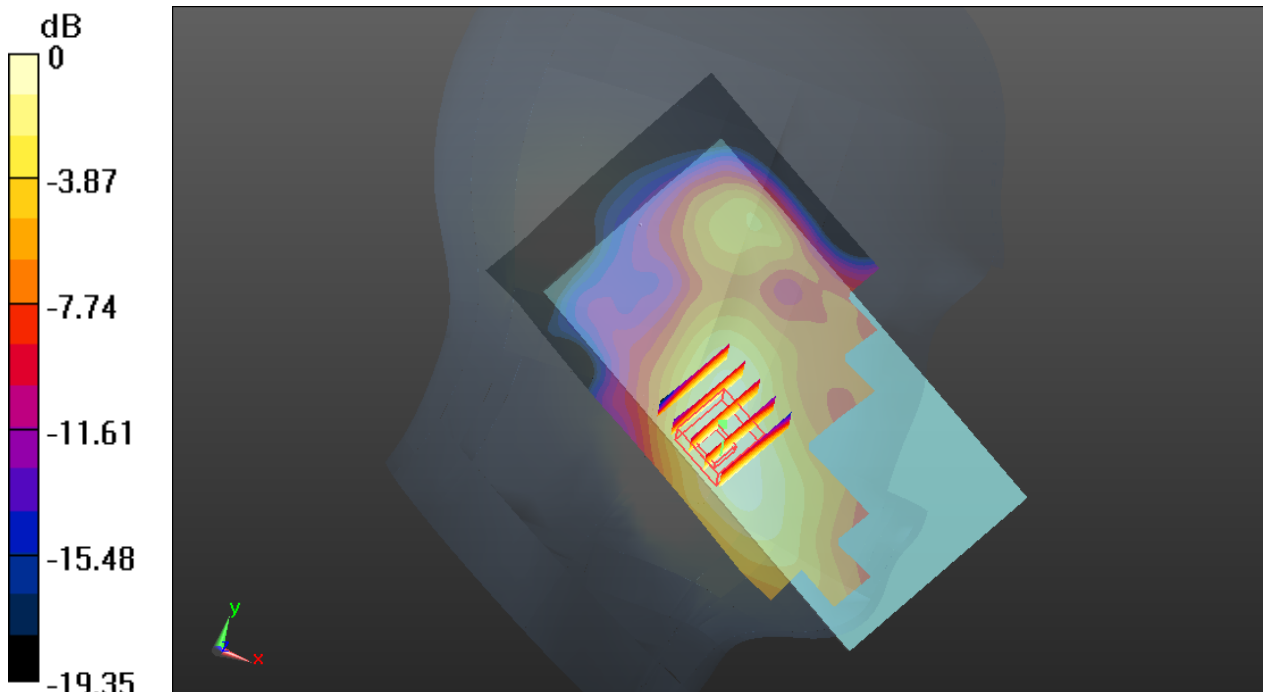

0 dB = 0.331 W/kg

03_WCDMA Band V_RMC 12.2K_Right Cheek_Ch4132

Communication System: UID 0, UMTS (0); Frequency: 826.4 MHz; Duty Cycle: 1:1
 Medium: HSL_835_140806 Medium parameters used: $f = 826.4$ MHz; $\sigma = 0.901$ S/m; $\epsilon_r = 43.016$;
 $\rho = 1000$ kg/m³
 Ambient Temperature : 23.3 °C; Liquid Temperature : 22.7 °C

DASY5 Configuration:

- Probe: EX3DV4 - SN3819; ConvF(9.68, 9.68, 9.68); Calibrated: 2013.11.27;
- Sensor-Surface: 2mm (Mechanical Surface Detection)
- Electronics: DAE3 Sn569; Calibrated: 2013.11.22
- Phantom: SAM2; Type: QD000P40CD; Serial: TP:1671
- Measurement SW: DASY52, Version 52.8 (7); SEMCAD X Version 14.6.10 (7164)

Ch4132/Area Scan (71x131x1): Interpolated grid: dx=15mm, dy=15mm

Maximum value of SAR (interpolated) = 0.236 W/kg

Ch4132/Zoom Scan (5x5x7)/Cube 0: Measurement grid: dx=8mm, dy=8mm, dz=5mm

Reference Value = 1.074 V/m; Power Drift = 0.15 dB

Peak SAR (extrapolated) = 0.249 W/kg

SAR(1 g) = 0.207 W/kg; SAR(10 g) = 0.162 W/kg

Maximum value of SAR (measured) = 0.233 W/kg

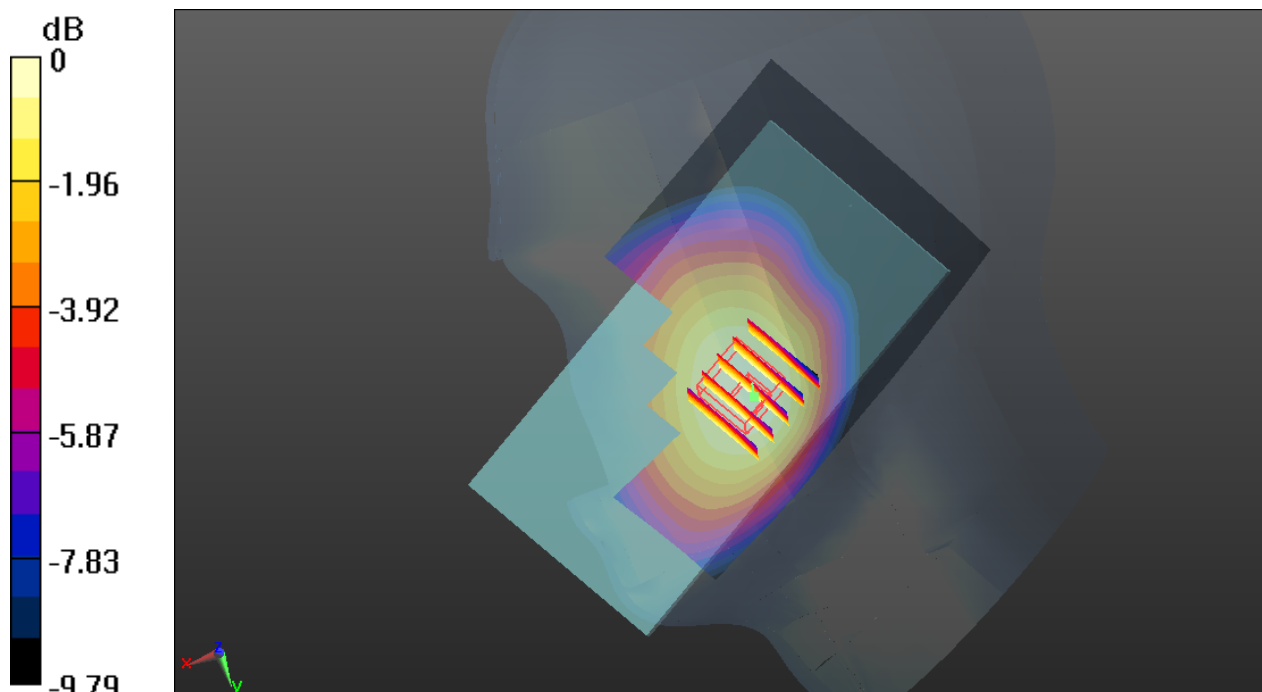

0 dB = 0.233 W/kg

56_WCDMA Dcpf 'IV_RMC 12.2K_Left Cheek_Ch1513

Communication System: UID 0, UMTS (0); Frequency: 1752.6 MHz; Duty Cycle: 1:1
Medium: HSL_1800_140827 Medium parameters used: $f = 1754.8$ MHz; $\sigma = 1.384$ S/m; $\epsilon_r = 41.307$;
 $\rho = 1000$ kg/m³
Ambient Temperature : 23.4 °C; Liquid Temperature : 22.7 °C

DASY5 Configuration:

- Probe: EX3DV4 - SN3819; ConvF(8.26, 8.26, 8.26); Calibrated: 2013.11.27;
- Sensor-Surface: 2mm (Mechanical Surface Detection)
- Electronics: DAE4 Sn910; Calibrated: 2014.07.22
- Phantom: SAM1; Type: QD000P40CD; Serial: TP:1670
- Measurement SW: DASY52, Version 52.8 (7); SEMCAD X Version 14.6.10 (7164)

Ch1513/Area Scan (71x131x1): Interpolated grid: dx=15mm, dy=15mm

Maximum value of SAR (interpolated) = 0.347 W/kg

Ch1513/Zoom Scan (5x5x7)/Cube 0: Measurement grid: dx=8mm, dy=8mm, dz=5mm

Reference Value = 5.950 V/m; Power Drift = 0.03 dB

Peak SAR (extrapolated) = 0.397 W/kg

SAR(1 g) = 0.280 W/kg; SAR(10 g) = 0.183 W/kg

Maximum value of SAR (measured) = 0.353 W/kg

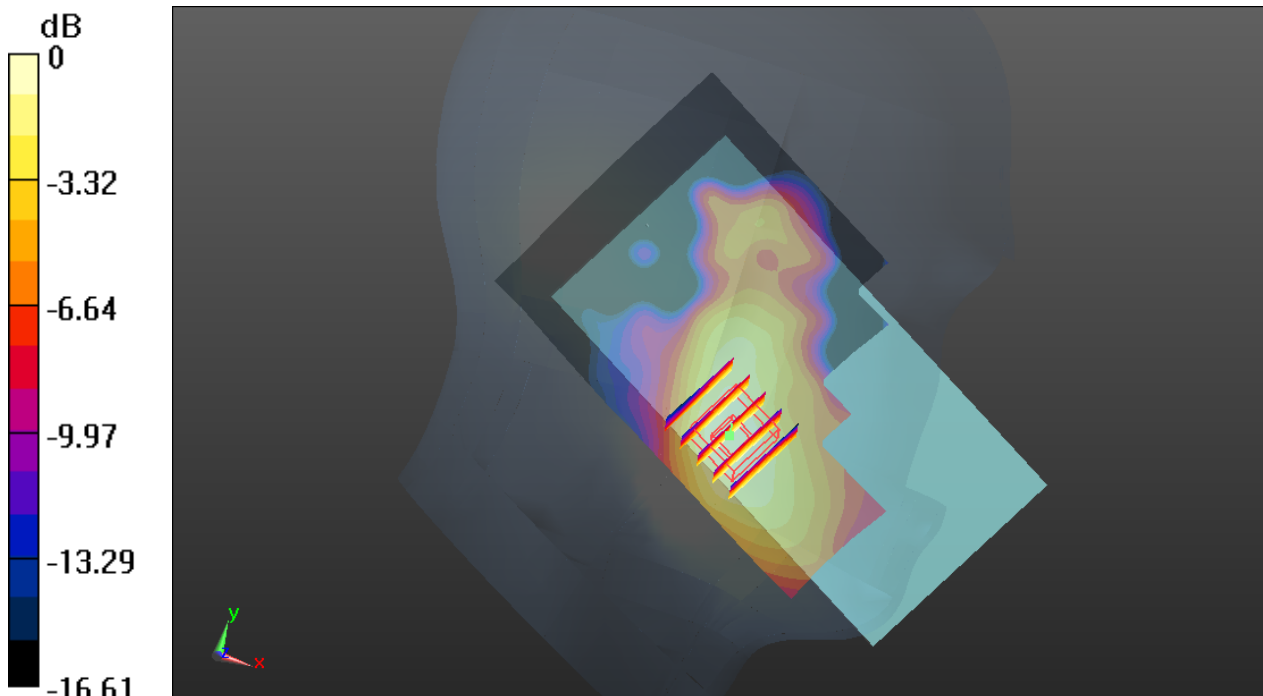

0 dB = 0.353 W/kg

04_WCDMA Band II_RMC 12.2K_Left Cheek_Ch9538

Communication System: UID 0, UMTS (0); Frequency: 1907.6 MHz; Duty Cycle: 1:1
 Medium: HSL_1900_140807 Medium parameters used: $f = 1909.8$ MHz; $\sigma = 1.455$ S/m; $\epsilon_r = 39.982$;
 $\rho = 1000$ kg/m³
 Ambient Temperature : 23.4 °C; Liquid Temperature : 22.6 °C

DASY5 Configuration:

- Probe: EX3DV4 - SN3819; ConvF(8, 8, 8); Calibrated: 2013.11.27;
- Sensor-Surface: 2mm (Mechanical Surface Detection)
- Electronics: DAE3 Sn569; Calibrated: 2013.11.22
- Phantom: SAM2; Type: QD000P40CD; Serial: TP:1671
- Measurement SW: DASY52, Version 52.8 (7); SEMCAD X Version 14.6.10 (7164)

Ch9538/Area Scan (71x131x1): Interpolated grid: dx=15mm, dy=15mm

Maximum value of SAR (interpolated) = 0.406 W/kg

Ch9538/Zoom Scan (5x5x7)/Cube 0: Measurement grid: dx=8mm, dy=8mm, dz=5mm

Reference Value = 1.007 V/m; Power Drift = 0.01 dB

Peak SAR (extrapolated) = 0.448 W/kg

SAR(1 g) = 0.301 W/kg; SAR(10 g) = 0.192 W/kg

Maximum value of SAR (measured) = 0.381 W/kg

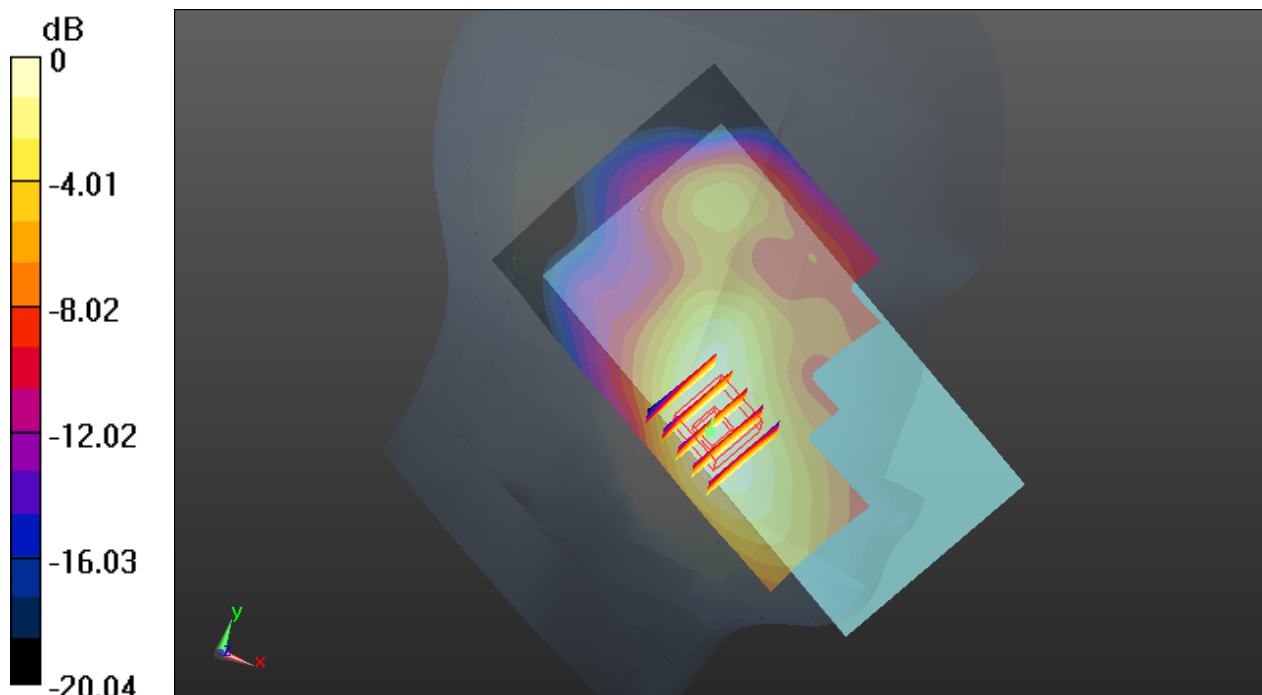

0 dB = 0.381 W/kg

05_LTE Band 12_10M_QPSK_1RB_49offset_Right Cheek_Ch23130

Communication System: UID 0, LTE (0); Frequency: 711 MHz; Duty Cycle: 1:1
 Medium: HSL_750_140806 Medium parameters used: $f = 711 \text{ MHz}$; $\sigma = 0.87 \text{ S/m}$; $\epsilon_r = 41.775$; $\rho = 1000 \text{ kg/m}^3$
 Ambient Temperature : $23.3 \text{ }^\circ\text{C}$; Liquid Temperature : $22.6 \text{ }^\circ\text{C}$

DASY5 Configuration:

- Probe: EX3DV4 - SN3819; ConvF(10.13, 10.13, 10.13); Calibrated: 2013.11.27;
- Sensor-Surface: 2mm (Mechanical Surface Detection)
- Electronics: DAE3 Sn569; Calibrated: 2013.11.22
- Phantom: SAM2; Type: QD000P40CD; Serial: TP:1671
- Measurement SW: DASY52, Version 52.8 (7); SEMCAD X Version 14.6.10 (7164)

Ch23130/Area Scan (71x131x1): Interpolated grid: $dx=15\text{mm}$, $dy=15\text{mm}$

Maximum value of SAR (interpolated) = 0.248 W/kg

Ch23130/Zoom Scan (5x5x7)/Cube 0: Measurement grid: $dx=8\text{mm}$, $dy=8\text{mm}$, $dz=5\text{mm}$

Reference Value = 1.272 V/m ; Power Drift = 0.07 dB

Peak SAR (extrapolated) = 0.261 W/kg

SAR(1 g) = 0.225 W/kg ; SAR(10 g) = 0.183 W/kg

Maximum value of SAR (measured) = 0.247 W/kg

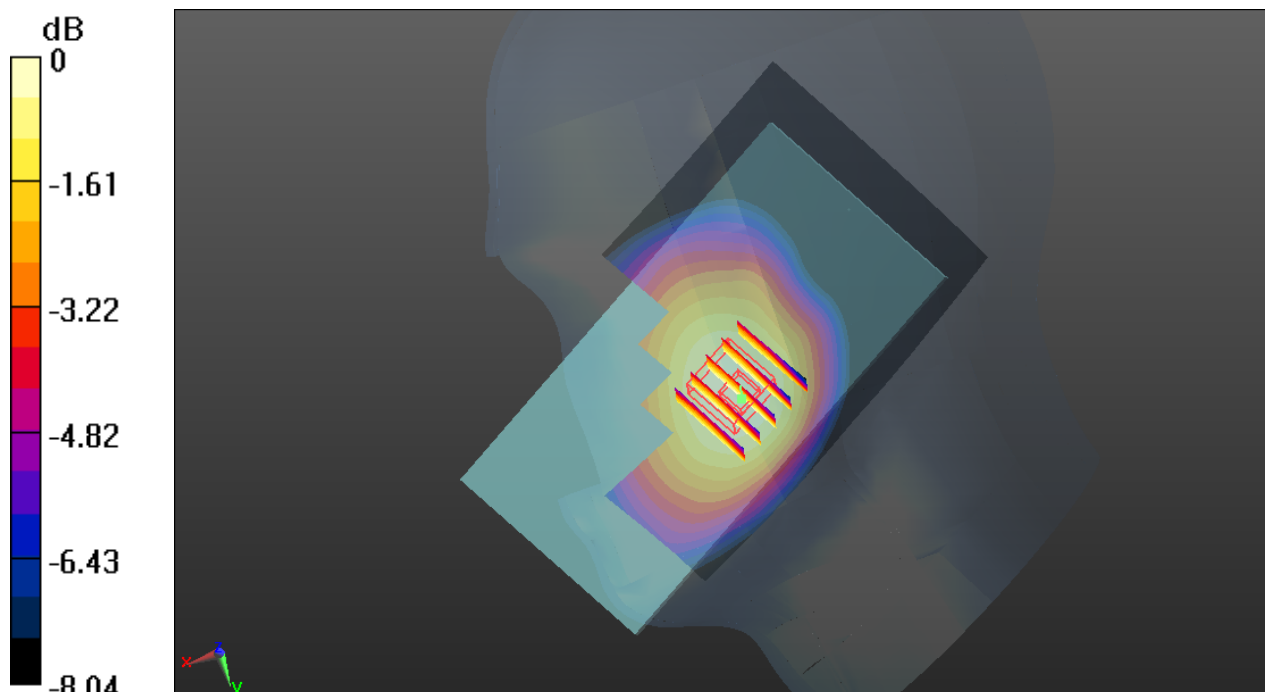

0 dB = 0.247 W/kg

06_LTE Band 17_10M_QPSK_1RB_49offset_Right Cheek_Ch23780

Communication System: UID 0, LTE (0); Frequency: 709 MHz; Duty Cycle: 1:1
Medium: HSL_750_140806 Medium parameters used: $f = 709$ MHz; $\sigma = 0.868$ S/m; $\epsilon_r = 41.785$; $\rho = 1000$ kg/m³
Ambient Temperature : 23.3 °C; Liquid Temperature : 22.6 °C

DASY5 Configuration:

- Probe: EX3DV4 - SN3819; ConvF(10.13, 10.13, 10.13); Calibrated: 2013.11.27;
- Sensor-Surface: 2mm (Mechanical Surface Detection)
- Electronics: DAE3 Sn569; Calibrated: 2013.11.22
- Phantom: SAM2; Type: QD000P40CD; Serial: TP:1671
- Measurement SW: DASY52, Version 52.8 (7); SEMCAD X Version 14.6.10 (7164)

Ch23780/Area Scan (71x131x1): Interpolated grid: dx=15mm, dy=15mm
Maximum value of SAR (interpolated) = 0.238 W/kg

Ch23780/Zoom Scan (5x5x7)/Cube 0: Measurement grid: dx=8mm, dy=8mm, dz=5mm
Reference Value = 1.261 V/m; Power Drift = 0.06 dB
Peak SAR (extrapolated) = 0.250 W/kg
SAR(1 g) = 0.214 W/kg; SAR(10 g) = 0.175 W/kg
Maximum value of SAR (measured) = 0.235 W/kg

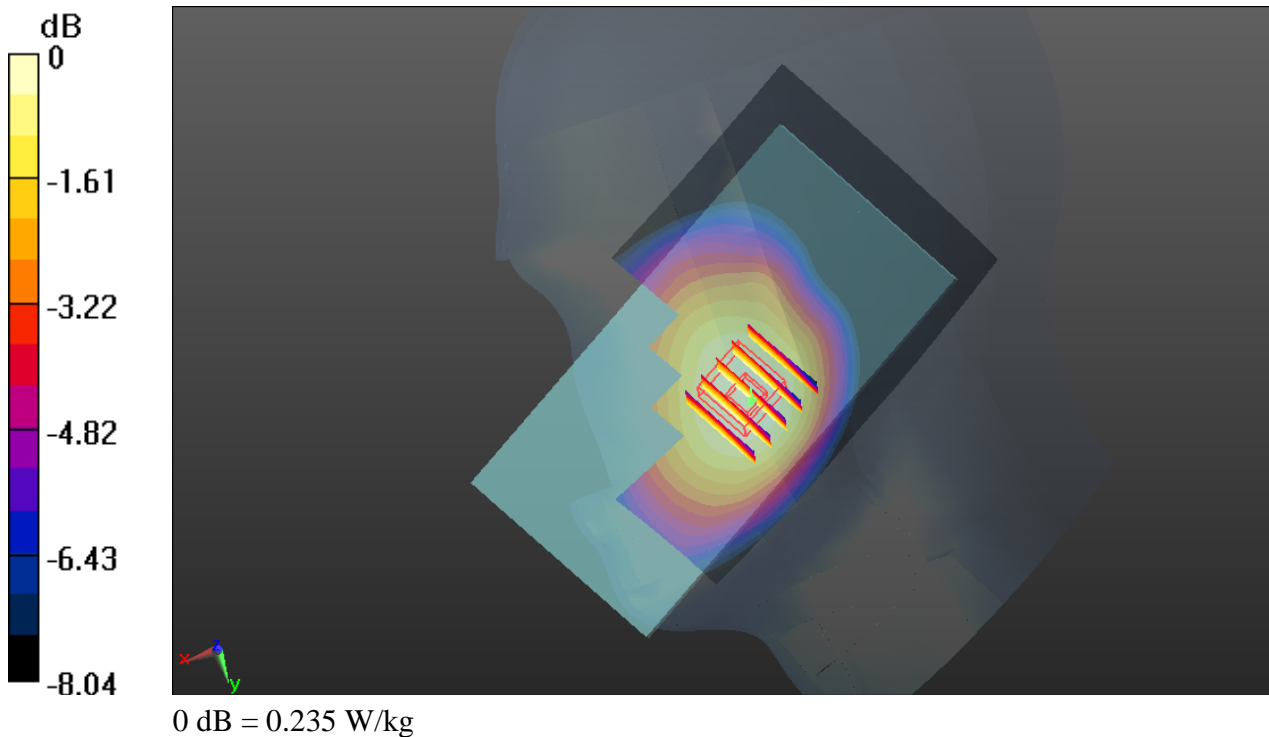

07_LTE Band 5_10M_QPSK_1RB_24offset_Right Cheek_Ch20600

Communication System: UID 0, LTE (0); Frequency: 844 MHz; Duty Cycle: 1:1
Medium: HSL_835_140806 Medium parameters used: $f = 844$ MHz; $\sigma = 0.92$ S/m; $\epsilon_r = 42.781$; $\rho = 1000$ kg/m³
Ambient Temperature : 23.3 °C; Liquid Temperature : 22.7 °C

DASY5 Configuration:

- Probe: EX3DV4 - SN3819; ConvF(9.68, 9.68, 9.68); Calibrated: 2013.11.27;
- Sensor-Surface: 2mm (Mechanical Surface Detection)
- Electronics: DAE3 Sn569; Calibrated: 2013.11.22
- Phantom: SAM2; Type: QD000P40CD; Serial: TP:1671
- Measurement SW: DASY52, Version 52.8 (7); SEMCAD X Version 14.6.10 (7164)

Ch20600/Area Scan (71x131x1): Interpolated grid: dx=15mm, dy=15mm

Maximum value of SAR (interpolated) = 0.207 W/kg

Ch20600/Zoom Scan (5x5x7)/Cube 0: Measurement grid: dx=8mm, dy=8mm, dz=5mm

Reference Value = 1.351 V/m; Power Drift = 0.01 dB

Peak SAR (extrapolated) = 0.214 W/kg

SAR(1 g) = 0.180 W/kg; SAR(10 g) = 0.140 W/kg

Maximum value of SAR (measured) = 0.200 W/kg

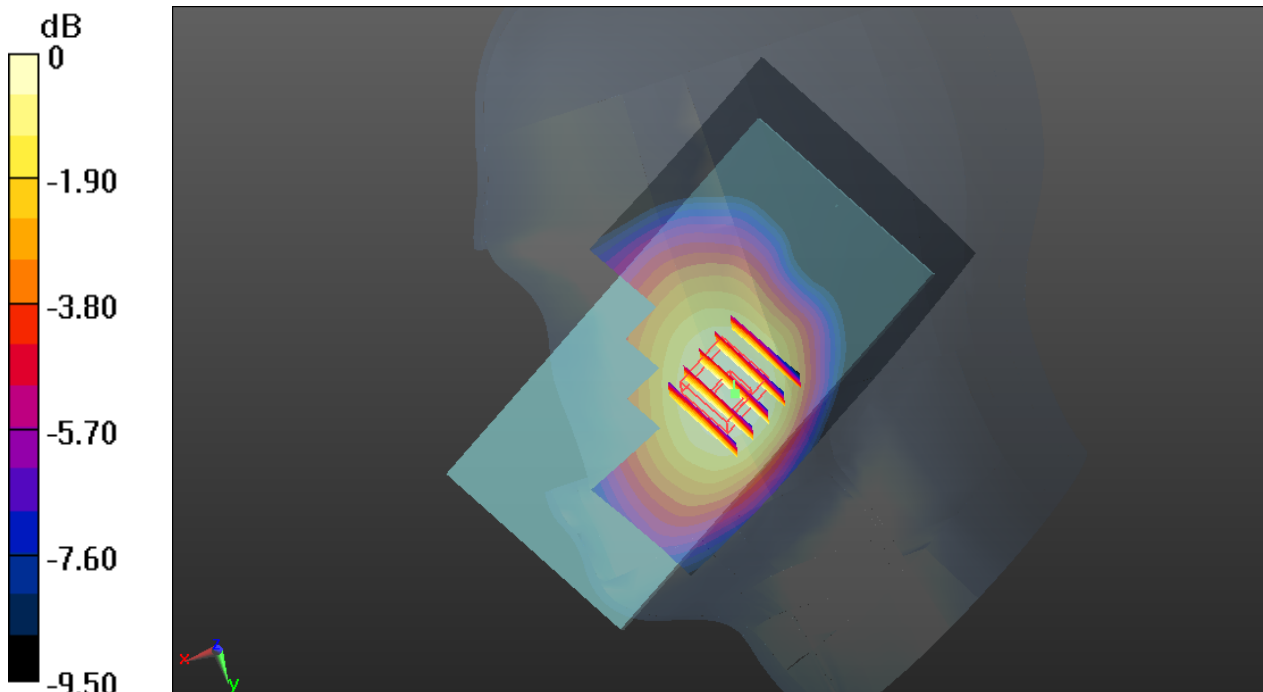

0 dB = 0.200 W/kg

08_LTE Band 26_15M_QPSK_1RB_74offset_Right Cheek_Ch26765

Communication System: UID 0, LTE (0); Frequency: 821.5 MHz; Duty Cycle: 1:1
Medium: HSL_835_140806 Medium parameters used: $f = 821.5$ MHz; $\sigma = 0.896$ S/m; $\epsilon_r = 43.081$;
 $\rho = 1000$ kg/m³
Ambient Temperature : 23.3 °C; Liquid Temperature : 22.7 °C

DASY5 Configuration:

- Probe: EX3DV4 - SN3819; ConvF(9.68, 9.68, 9.68); Calibrated: 2013.11.27;
- Sensor-Surface: 2mm (Mechanical Surface Detection)
- Electronics: DAE3 Sn569; Calibrated: 2013.11.22
- Phantom: SAM2; Type: QD000P40CD; Serial: TP:1671
- Measurement SW: DASY52, Version 52.8 (7); SEMCAD X Version 14.6.10 (7164)

Ch26765/Area Scan (71x131x1): Interpolated grid: dx=15mm, dy=15mm
Maximum value of SAR (interpolated) = 0.227 W/kg

Ch26765/Zoom Scan (5x5x7)/Cube 0: Measurement grid: dx=8mm, dy=8mm, dz=5mm
Reference Value = 1.150 V/m; Power Drift = 0.02 dB
Peak SAR (extrapolated) = 0.241 W/kg
SAR(1 g) = 0.202 W/kg; SAR(10 g) = 0.158 W/kg
Maximum value of SAR (measured) = 0.226 W/kg

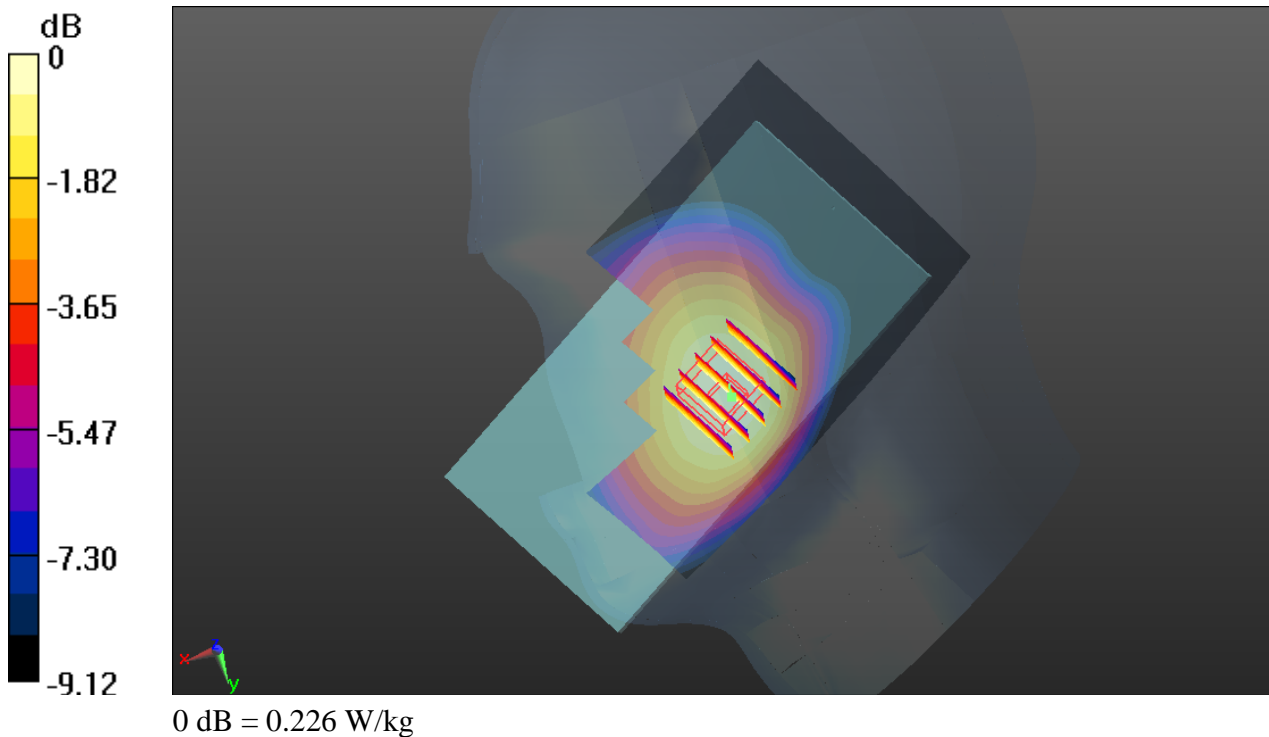

09_LTE Band 4_20M_QPSK_50RB_0offset_Left Cheek_Ch20300

Communication System: UID 0, LTE (0); Frequency: 1745 MHz;Duty Cycle: 1:1
Medium: HSL_1800_140816 Medium parameters used: $f = 1745$ MHz; $\sigma = 1.386$ S/m; $\epsilon_r = 40.553$;
 $\rho = 1000$ kg/m³
Ambient Temperature : 23.4 °C; Liquid Temperature : 22.7 °C

DASY5 Configuration:

- Probe: EX3DV4 - SN3819; ConvF(8.26, 8.26, 8.26); Calibrated: 2013.11.27;
- Sensor-Surface: 2mm (Mechanical Surface Detection)
- Electronics: DAE3 Sn569; Calibrated: 2013.11.22
- Phantom: SAM2; Type: QD000P40CD; Serial: TP:1671
- Measurement SW: DASY52, Version 52.8 (7); SEMCAD X Version 14.6.10 (7164)

Ch20300/Area Scan (71x131x1): Interpolated grid: dx=15mm, dy=15mm

Maximum value of SAR (interpolated) = 0.286 W/kg

Ch20300/Zoom Scan (5x5x7)/Cube 0: Measurement grid: dx=8mm, dy=8mm, dz=5mm

Reference Value = 2.236 V/m; Power Drift = -0.05 dB

Peak SAR (extrapolated) = 0.341 W/kg

SAR(1 g) = 0.250 W/kg; SAR(10 g) = 0.169 W/kg

Maximum value of SAR (measured) = 0.302 W/kg

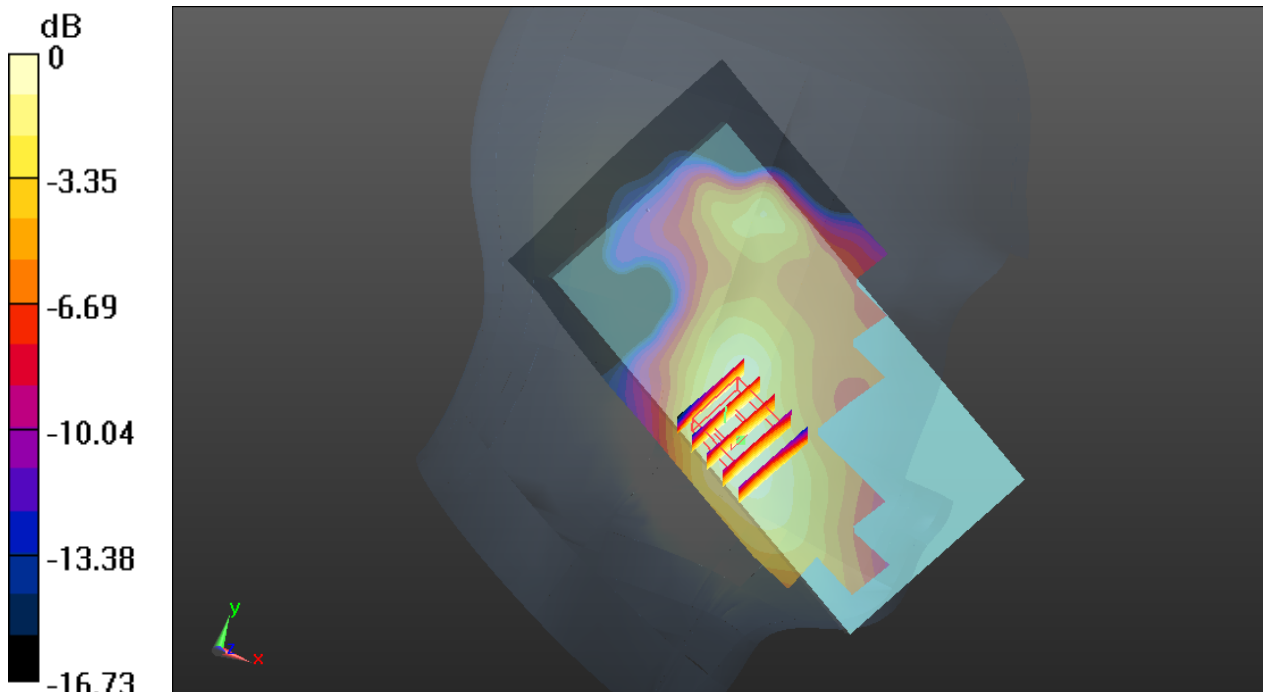

0 dB = 0.302 W/kg

10_LTE Band 2_20M_QPSK_1RB_0offset_Left Cheek_Ch19100

Communication System: UID 0, LTE (0); Frequency: 1900 MHz; Duty Cycle: 1:1
Medium: HSL_1900_140816 Medium parameters used: $f = 1900$ MHz; $\sigma = 1.422$ S/m; $\epsilon_r = 40.315$;
 $\rho = 1000$ kg/m³
Ambient Temperature : 23.5 °C; Liquid Temperature : 22.7 °C

DASY5 Configuration:

- Probe: EX3DV4 - SN3819; ConvF(8, 8, 8); Calibrated: 2013.11.27;
- Sensor-Surface: 2mm (Mechanical Surface Detection)
- Electronics: DAE3 Sn569; Calibrated: 2013.11.22
- Phantom: SAM2; Type: QD000P40CD; Serial: TP:1671
- Measurement SW: DASY52, Version 52.8 (7); SEMCAD X Version 14.6.10 (7164)

Ch19100/Area Scan (71x131x1): Interpolated grid: dx=15mm, dy=15mm

Maximum value of SAR (interpolated) = 0.344 W/kg

Ch19100/Zoom Scan (5x5x7)/Cube 0: Measurement grid: dx=8mm, dy=8mm, dz=5mm

Reference Value = 1.848 V/m; Power Drift = -0.09 dB

Peak SAR (extrapolated) = 0.411 W/kg

SAR(1 g) = 0.245 W/kg; SAR(10 g) = 0.160 W/kg

Maximum value of SAR (measured) = 0.319 W/kg

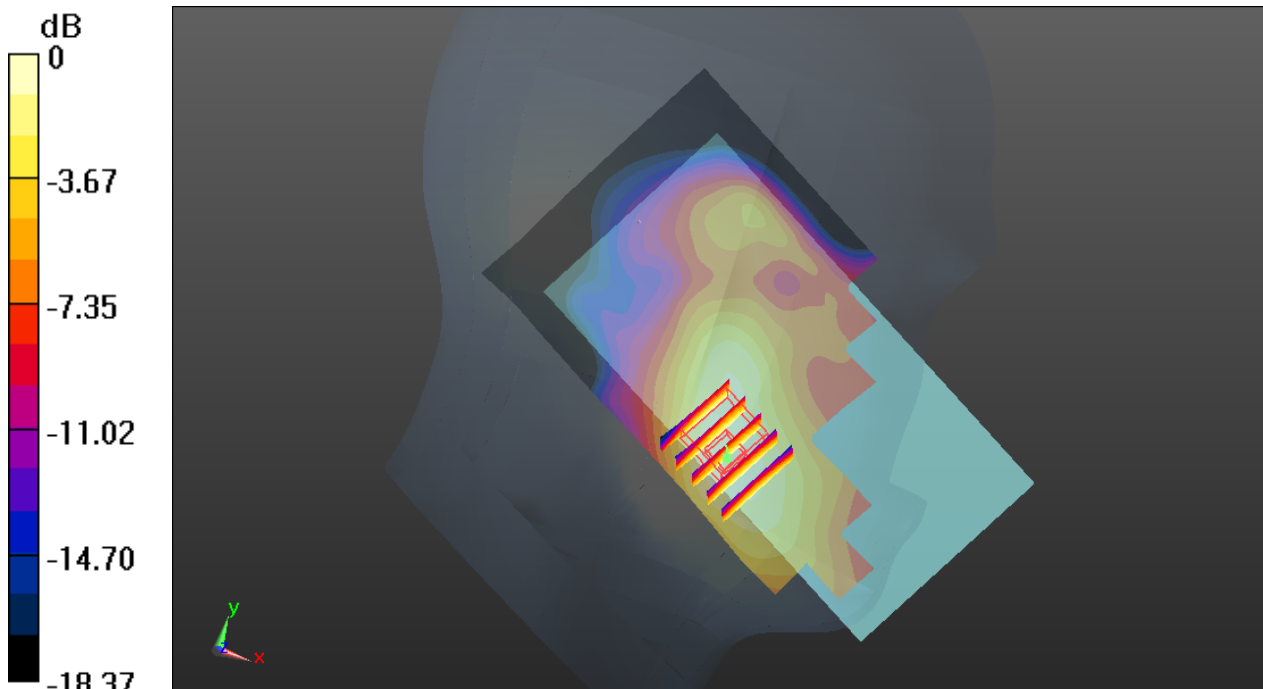

0 dB = 0.319 W/kg

11_LTE Band 25_20M_QPSK_1RB_99offset_Right Cheek_Ch26590

Communication System: UID 0, LTE (0); Frequency: 1905 MHz; Duty Cycle: 1:1
Medium: HSL_1900_140816 Medium parameters used: $f = 1905$ MHz; $\sigma = 1.427$ S/m; $\epsilon_r = 40.288$;
 $\rho = 1000$ kg/m³
Ambient Temperature : 23.5 °C; Liquid Temperature : 22.7 °C

DASY5 Configuration:

- Probe: EX3DV4 - SN3819; ConvF(8, 8, 8); Calibrated: 2013.11.27;
- Sensor-Surface: 2mm (Mechanical Surface Detection)
- Electronics: DAE3 Sn569; Calibrated: 2013.11.22
- Phantom: SAM2; Type: QD000P40CD; Serial: TP:1671
- Measurement SW: DASY52, Version 52.8 (7); SEMCAD X Version 14.6.10 (7164)

Ch26590/Area Scan (71x131x1): Interpolated grid: dx=15mm, dy=15mm

Maximum value of SAR (interpolated) = 0.271 W/kg

Ch26590/Zoom Scan (5x5x7)/Cube 0: Measurement grid: dx=8mm, dy=8mm, dz=5mm

Reference Value = 1.192 V/m; Power Drift = 0.01 dB

Peak SAR (extrapolated) = 0.300 W/kg

SAR(1 g) = 0.202 W/kg; SAR(10 g) = 0.129 W/kg

Maximum value of SAR (measured) = 0.253 W/kg

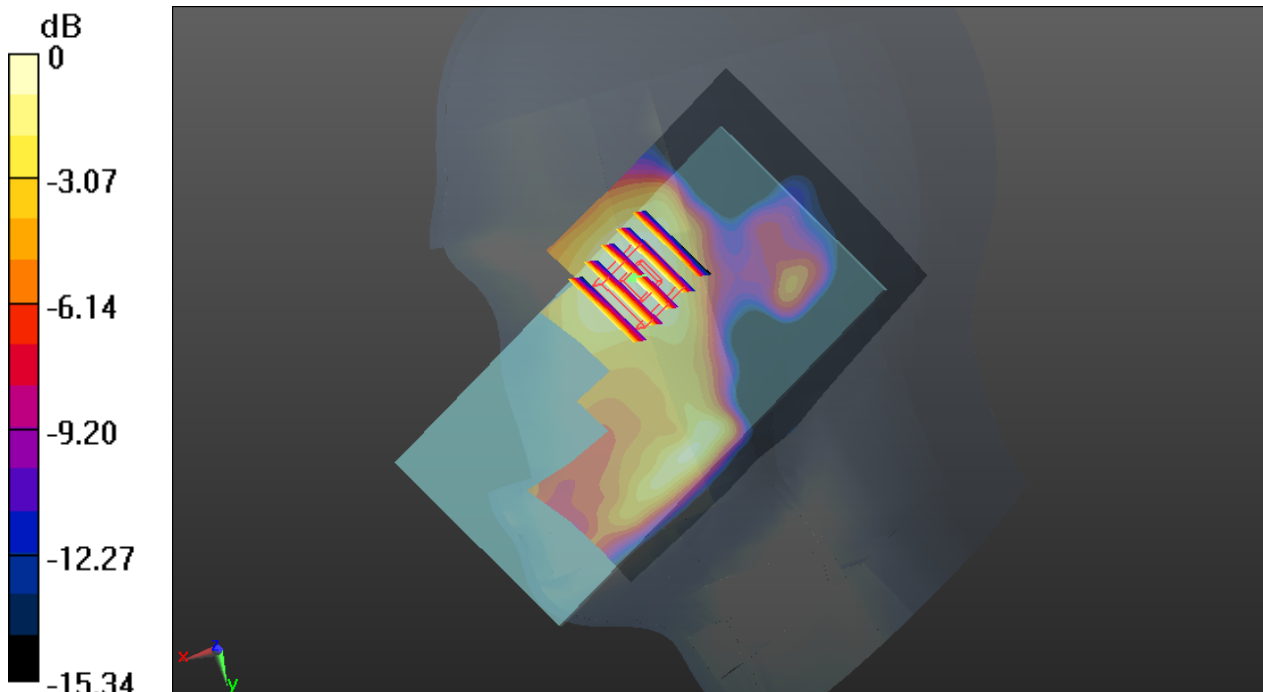

0 dB = 0.253 W/kg

12_LTE Band 7_20M_QPSK_50RB_24offset_Left Cheek_Ch21350

Communication System: UID 0, LTE (0); Frequency: 2560 MHz; Duty Cycle: 1:1
Medium: HSL_2600_140815 Medium parameters used: $f = 2560$ MHz; $\sigma = 2.008$ S/m; $\epsilon_r = 38.529$;
 $\rho = 1000$ kg/m³
Ambient Temperature : 23.3 °C; Liquid Temperature : 22.7 °C

DASY5 Configuration:

- Probe: EX3DV4 - SN3819; ConvF(7.06, 7.06, 7.06); Calibrated: 2013.11.27;
- Sensor-Surface: 2mm (Mechanical Surface Detection)
- Electronics: DAE3 Sn569; Calibrated: 2013.11.22
- Phantom: SAM1; Type: QD000P40CD; Serial: TP:1670
- Measurement SW: DASY52, Version 52.8 (7); SEMCAD X Version 14.6.10 (7164)

Ch21350/Area Scan (91x161x1): Interpolated grid: dx=12mm, dy=12mm

Maximum value of SAR (interpolated) = 0.146 W/kg

Ch21350/Zoom Scan (7x7x7)/Cube 0: Measurement grid: dx=5mm, dy=5mm, dz=5mm

Reference Value = 2.548 V/m; Power Drift = -0.07 dB

Peak SAR (extrapolated) = 0.206 W/kg

SAR(1 g) = 0.060 W/kg; SAR(10 g) = 0.019 W/kg

Maximum value of SAR (measured) = 0.139 W/kg

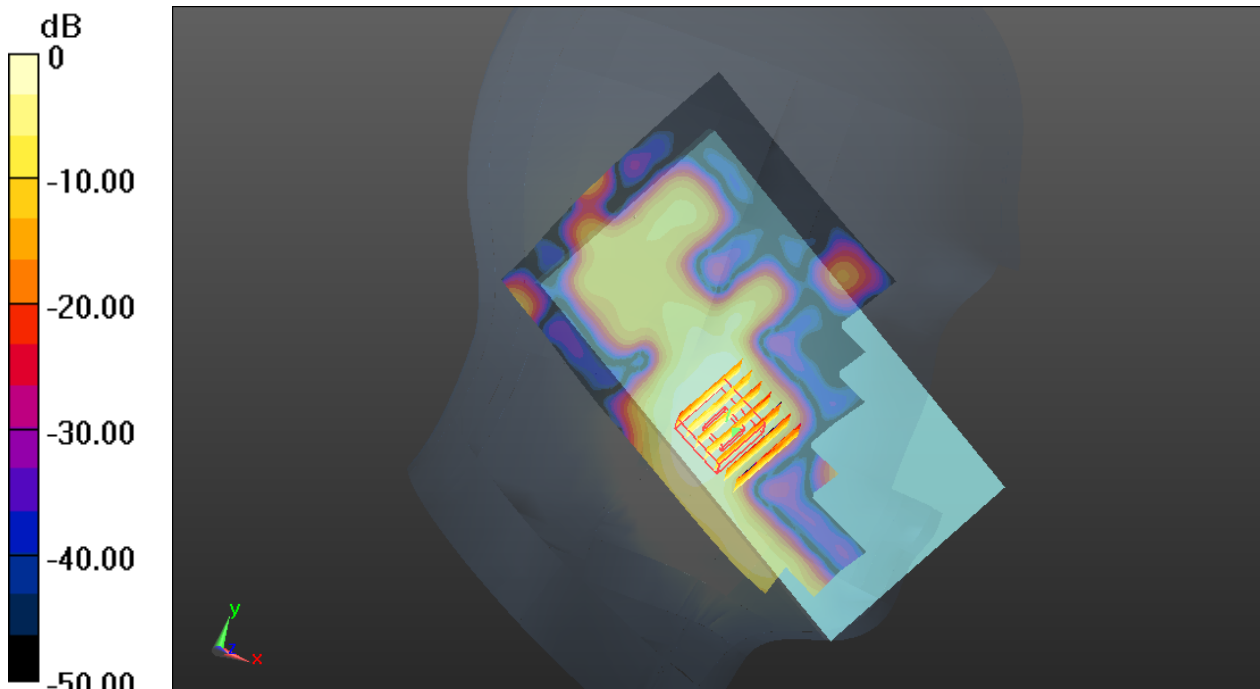

0 dB = 0.139 W/kg

13_WLAN2.4GHz_802.11b 1Mbps_Right Cheek_Ch6

Communication System: UID 0, WIFI (0); Frequency: 2437 MHz; Duty Cycle: 1:1.024
Medium: HSL_2450_140817 Medium parameters used: $f = 2437$ MHz; $\sigma = 1.82$ S/m; $\epsilon_r = 39.699$; $\rho = 1000$ kg/m³
Ambient Temperature : 23.3 °C; Liquid Temperature : 22.7 °C

DASY5 Configuration:

- Probe: EX3DV4 - SN3819; ConvF(7.22, 7.22, 7.22); Calibrated: 2013.11.27;
- Sensor-Surface: 2mm (Mechanical Surface Detection)
- Electronics: DAE3 Sn569; Calibrated: 2013.11.22
- Phantom: SAM2; Type: QD000P40CD; Serial: TP:1671
- Measurement SW: DASY52, Version 52.8 (7); SEMCAD X Version 14.6.10 (7164)

Ch6/Area Scan (91x161x1): Interpolated grid: dx=12mm, dy=12mm

Maximum value of SAR (interpolated) = 2.15 W/kg

Ch6/Zoom Scan (7x7x7)/Cube 0: Measurement grid: dx=5mm, dy=5mm, dz=5mm

Reference Value = 1.563 V/m; Power Drift = 0.09 dB

Peak SAR (extrapolated) = 2.79 W/kg

SAR(1 g) = 1.150 W/kg; SAR(10 g) = 0.635 W/kg

Maximum value of SAR (measured) = 1.96 W/kg

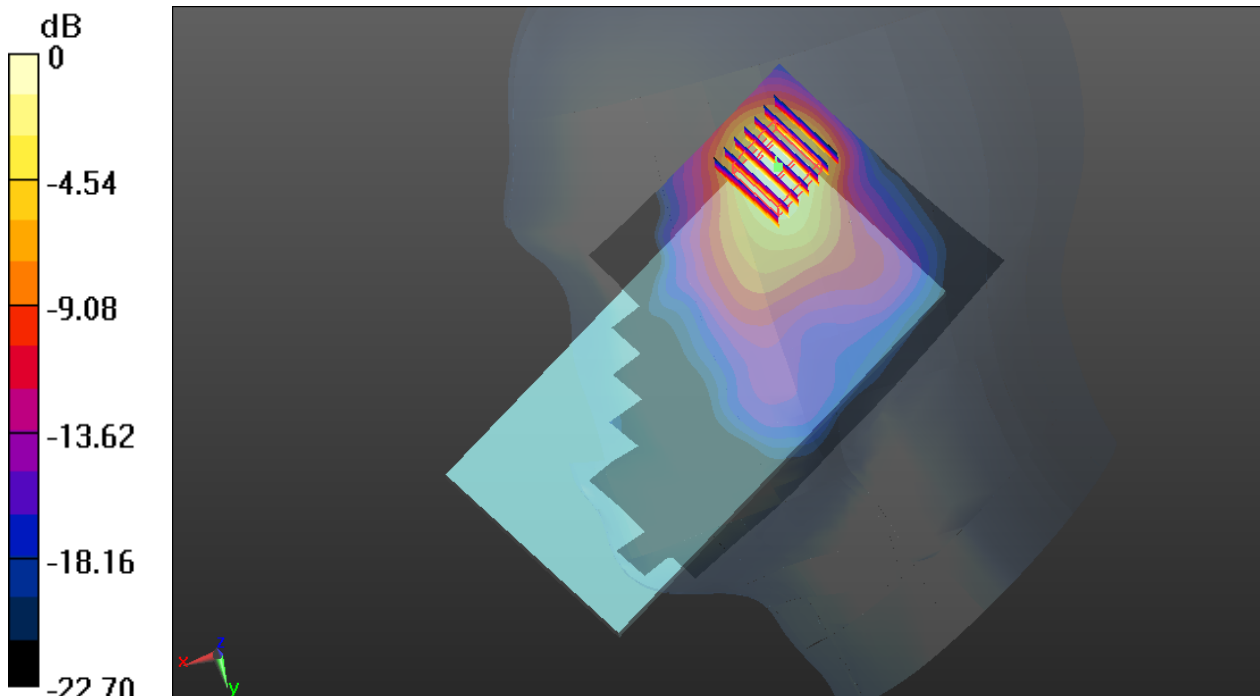

0 dB = 1.96 W/kg

14_GSM850_GPRS(2 Tx slots)_Back_1cm_Ch189

Communication System: UID 0, GPRS/EDGE10 (0); Frequency: 836.4 MHz; Duty Cycle: 1:4.15
Medium: MSL_835_140805 Medium parameters used: $f = 836.4$ MHz; $\sigma = 0.978$ S/m; $\epsilon_r = 54.384$;
 $\rho = 1000$ kg/m³
Ambient Temperature : 23.2 °C; Liquid Temperature : 22.6 °C

DASY5 Configuration:

- Probe: EX3DV4 - SN3819; ConvF(9.54, 9.54, 9.54); Calibrated: 2013.11.27;
- Sensor-Surface: 2mm (Mechanical Surface Detection)
- Electronics: DAE3 Sn569; Calibrated: 2013.11.22
- Phantom: SAM2; Type: QD000P40CD; Serial: TP:1671
- Measurement SW: DASY52, Version 52.8 (7); SEMCAD X Version 14.6.10 (7164)

Ch189/Area Scan (71x131x1): Interpolated grid: dx=15mm, dy=15mm

Maximum value of SAR (interpolated) = 0.608 W/kg

Ch189/Zoom Scan (5x5x7)/Cube 0: Measurement grid: dx=8mm, dy=8mm, dz=5mm

Reference Value = 2.037 V/m; Power Drift = 0.03 dB

Peak SAR (extrapolated) = 0.852 W/kg

SAR(1 g) = 0.498 W/kg; SAR(10 g) = 0.364 W/kg

Maximum value of SAR (measured) = 0.605 W/kg

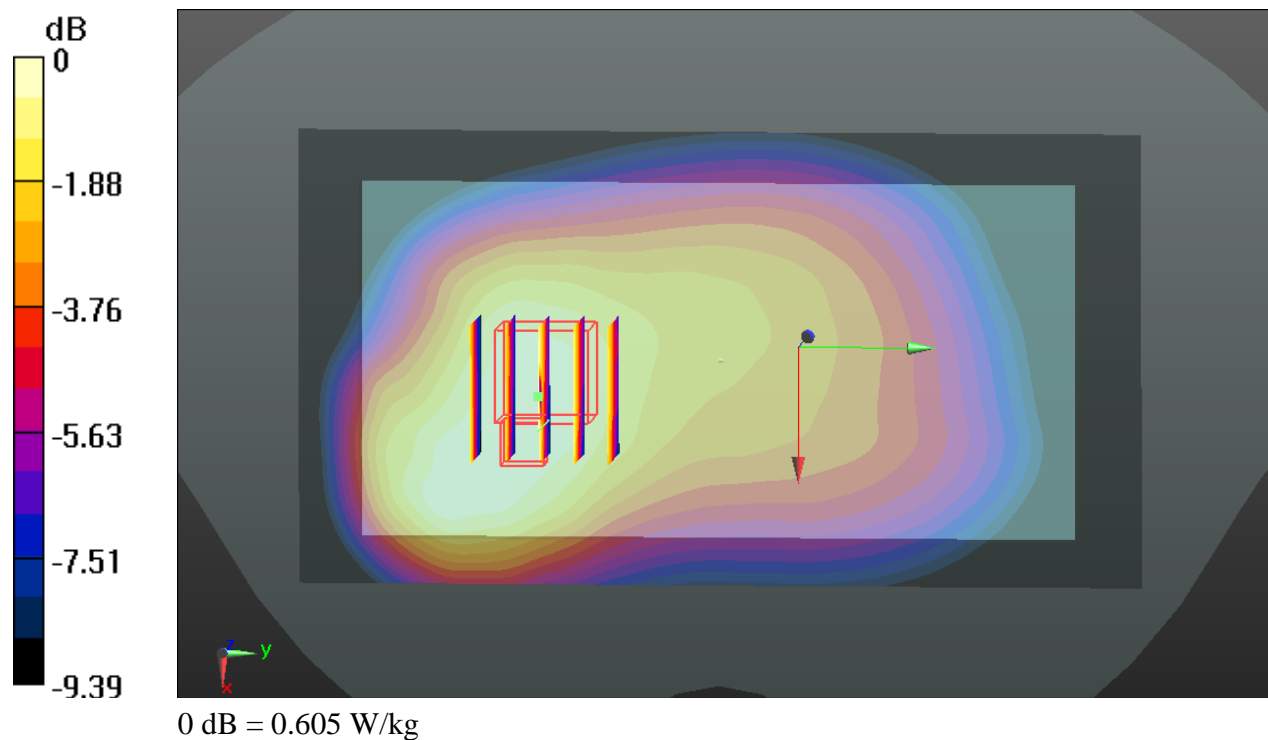

15_GSM1900_GPRS(2 Tx slots)_Bottom Side_1cm_Ch661

Communication System: UID 0, GPRS/EDGE10 (0); Frequency: 1880 MHz; Duty Cycle: 1:4.15
Medium: MSL_1900_140813 Medium parameters used: $f = 1880$ MHz; $\sigma = 1.521$ S/m; $\epsilon_r = 53.575$;
 $\rho = 1000$ kg/m³
Ambient Temperature : 23.2 °C; Liquid Temperature : 22.6 °C

DASY5 Configuration:

- Probe: EX3DV4 - SN3819; ConvF(7.55, 7.55, 7.55); Calibrated: 2013.11.27;
- Sensor-Surface: 2mm (Mechanical Surface Detection)
- Electronics: DAE3 Sn569; Calibrated: 2013.11.22
- Phantom: SAM2; Type: QD000P40CD; Serial: TP:1671
- Measurement SW: DASY52, Version 52.8 (7); SEMCAD X Version 14.6.10 (7164)

Ch661/Area Scan (41x81x1): Interpolated grid: dx=15mm, dy=15mm

Maximum value of SAR (interpolated) = 0.910 W/kg

Ch661/Zoom Scan (5x5x7)/Cube 0: Measurement grid: dx=8mm, dy=8mm, dz=5mm

Reference Value = 5.345 V/m; Power Drift = -0.07 dB

Peak SAR (extrapolated) = 1.22 W/kg

SAR(1 g) = 0.686 W/kg; SAR(10 g) = 0.354 W/kg

Maximum value of SAR (measured) = 0.990 W/kg

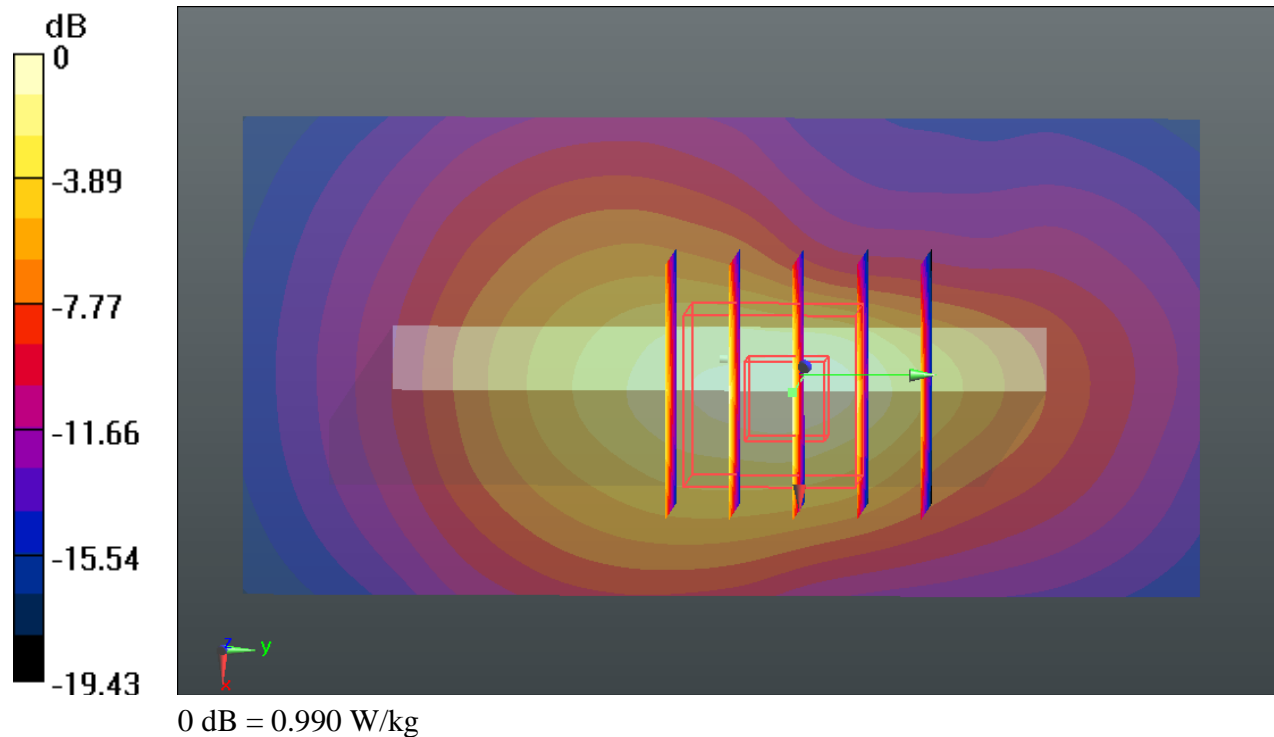

16_WCDMA Band V_RMC 12.2K_Back_1cm_Ch4132

Communication System: UID 0, UMTS (0); Frequency: 826.4 MHz; Duty Cycle: 1:1
Medium: MSL_835_140805 Medium parameters used: $f = 826.4$ MHz; $\sigma = 0.969$ S/m; $\epsilon_r = 54.456$;
 $\rho = 1000$ kg/m³
Ambient Temperature : 23.2 °C; Liquid Temperature : 22.6 °C

DASY5 Configuration:

- Probe: EX3DV4 - SN3819; ConvF(9.54, 9.54, 9.54); Calibrated: 2013.11.27;
- Sensor-Surface: 2mm (Mechanical Surface Detection)
- Electronics: DAE3 Sn569; Calibrated: 2013.11.22
- Phantom: SAM2; Type: QD000P40CD; Serial: TP:1671
- Measurement SW: DASY52, Version 52.8 (7); SEMCAD X Version 14.6.10 (7164)

Ch4132/Area Scan (71x131x1): Interpolated grid: dx=15mm, dy=15mm

Maximum value of SAR (interpolated) = 0.357 W/kg

Ch4132/Zoom Scan (5x5x7)/Cube 0: Measurement grid: dx=8mm, dy=8mm, dz=5mm

Reference Value = 1.495 V/m; Power Drift = 0.08 dB

Peak SAR (extrapolated) = 0.392 W/kg

SAR(1 g) = 0.305 W/kg; SAR(10 g) = 0.224 W/kg

Maximum value of SAR (measured) = 0.351 W/kg

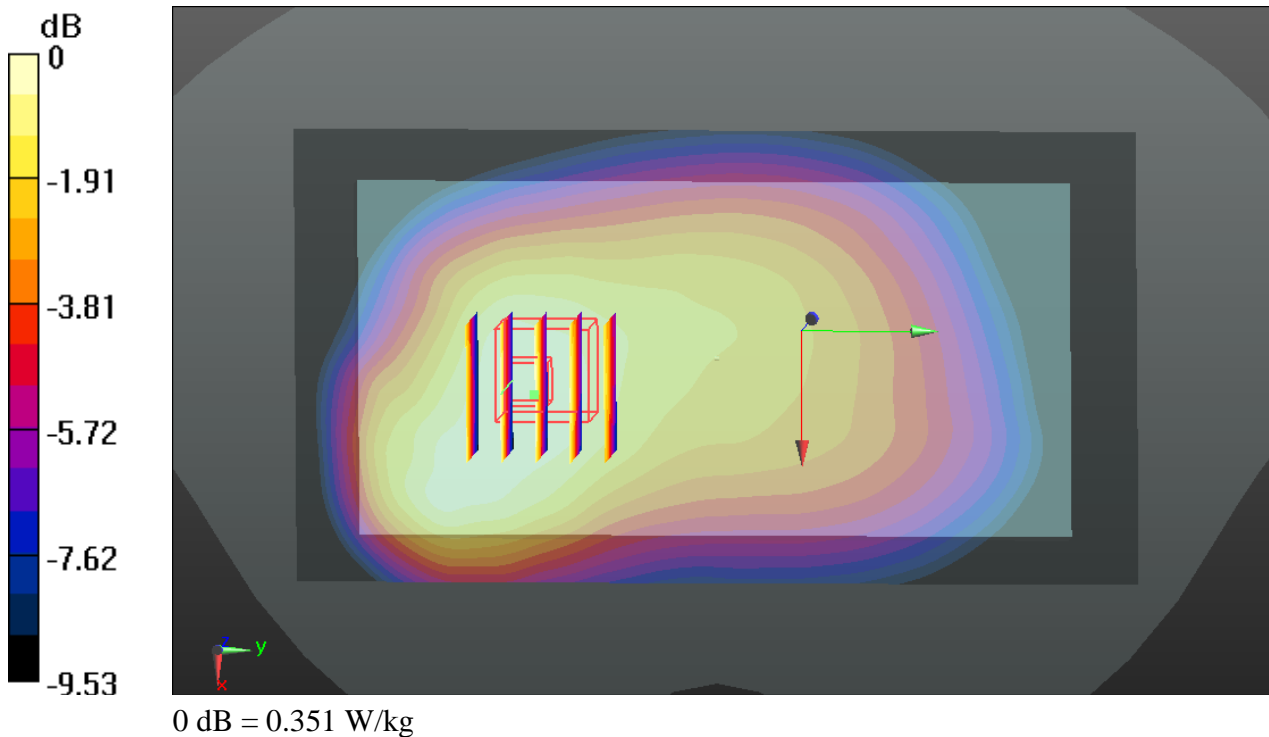

37_WCDMA Dcpf 'IV_RMC 12.2K_Bottom Side_1cm_Ch1513

Communication System: UID 0, UMTS (0); Frequency: 1752.6 MHz; Duty Cycle: 1:1
 Medium: MSL_1800_140827 Medium parameters used: $f = 175408$ MHz; $\sigma = 1.529$ S/m; $\epsilon_r = 52.612$;
 $\rho = 1000$ kg/m³
 Ambient Temperature : 23.4 °C; Liquid Temperature : 22.6 °C

DASY5 Configuration:

- Probe: EX3DV4 - SN3819; ConvF(8.01, 8.01, 8.01); Calibrated: 2013.11.27;
- Sensor-Surface: 2mm (Mechanical Surface Detection)
- Electronics: DAE4 Sn910; Calibrated: 2014.07.22
- Phantom: SAM2; Type: QD000P40CD; Serial: TP:1671
- Measurement SW: DASY52, Version 52.8 (7); SEMCAD X Version 14.6.10 (7164)

Ch1513/Area Scan (41x71x1): Interpolated grid: dx=15mm, dy=15mm

Maximum value of SAR (interpolated) = 0.765 W/kg

Ch1513/Zoom Scan (5x5x7)/Cube 0: Measurement grid: dx=8mm, dy=8mm, dz=5mm

Reference Value = 3.427 V/m; Power Drift = 0.09 dB

Peak SAR (extrapolated) = 1.07 W/kg

SAR(1 g) = 0.650 W/kg; SAR(10 g) = 0.351 W/kg

Maximum value of SAR (measured) = 0.864 W/kg

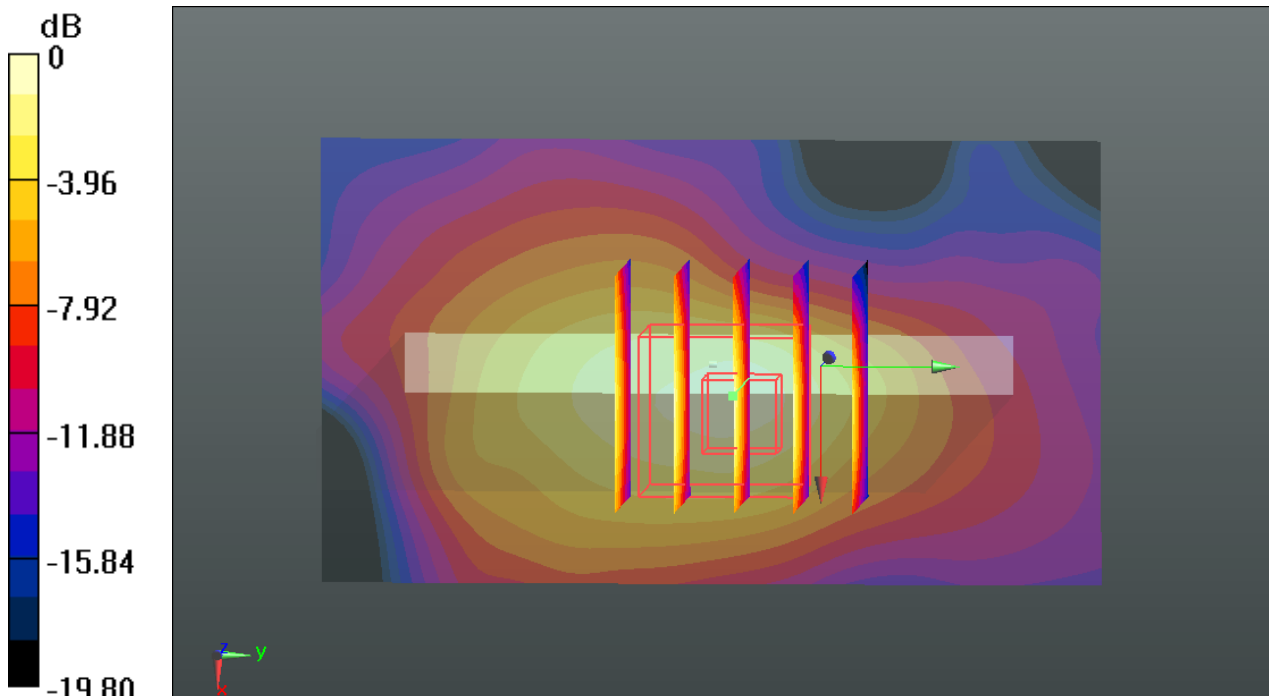

0 dB = 0.864 W/kg

17_WCDMA Band II_RMC 12.2K_Bottom Side_1cm_Ch9262

Communication System: UID 0, UMTS (0); Frequency: 1852.4 MHz; Duty Cycle: 1:1
 Medium: MSL_1900_140803 Medium parameters used: $f = 1852.4 \text{ MHz}$; $\sigma = 1.527 \text{ S/m}$; $\epsilon_r = 54.381$; $\rho = 1000 \text{ kg/m}^3$
 Ambient Temperature : $23.2 \text{ }^\circ\text{C}$; Liquid Temperature : $22.7 \text{ }^\circ\text{C}$

DASY5 Configuration:

- Probe: EX3DV4 - SN3819; ConvF(7.55, 7.55, 7.55); Calibrated: 2013.11.27;
- Sensor-Surface: 2mm (Mechanical Surface Detection)
- Electronics: DAE3 Sn569; Calibrated: 2013.11.22
- Phantom: SAM2; Type: QD000P40CD; Serial: TP:1671
- Measurement SW: DASY52, Version 52.8 (7); SEMCAD X Version 14.6.10 (7164)

Ch9262/Area Scan (41x81x1): Interpolated grid: $dx=15\text{mm}$, $dy=15\text{mm}$

Maximum value of SAR (interpolated) = 1.30 W/kg

Ch9262/Zoom Scan (5x5x7)/Cube 0: Measurement grid: $dx=8\text{mm}$, $dy=8\text{mm}$, $dz=5\text{mm}$

Reference Value = 5.291 V/m ; Power Drift = 0.01 dB

Peak SAR (extrapolated) = 1.72 W/kg

SAR(1 g) = 0.988 W/kg ; SAR(10 g) = 0.526 W/kg

Maximum value of SAR (measured) = 1.40 W/kg

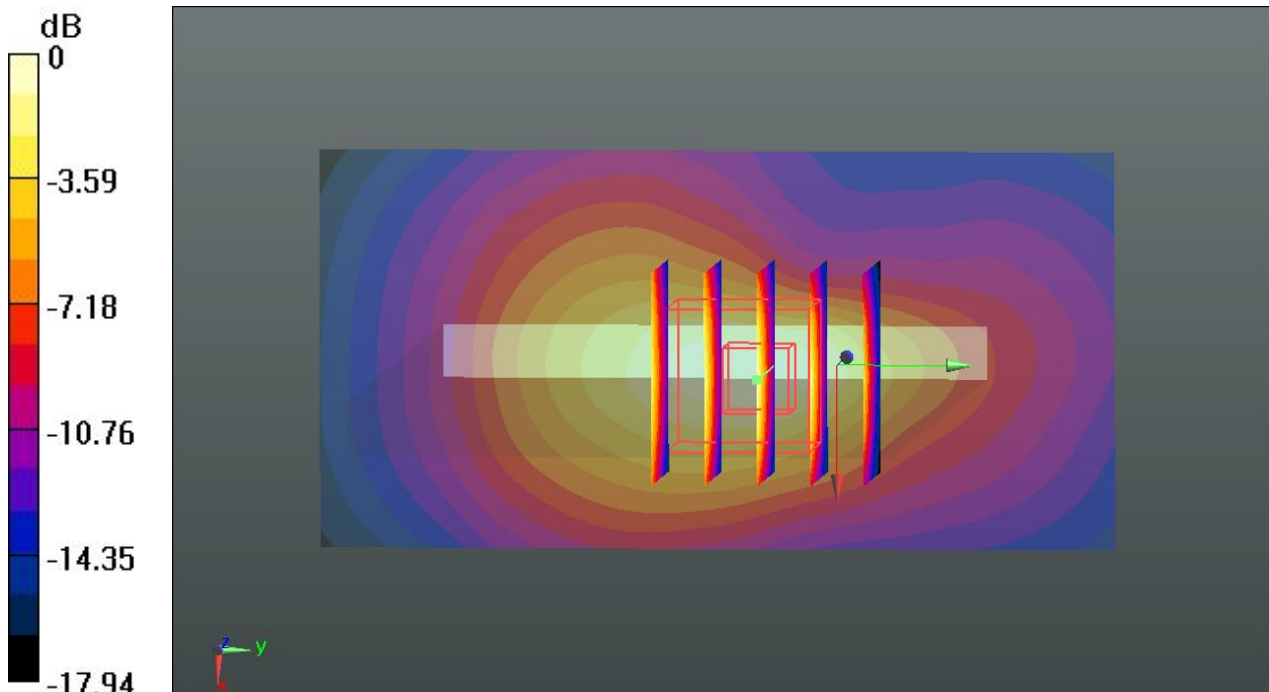

0 dB = 1.40 W/kg

18_LTE Band 12_10M_QPSK_1RB_49offset_Front_1cm_Ch23130

Communication System: UID 0, LTE (0); Frequency: 711 MHz; Duty Cycle: 1:1
Medium: MSL_750_140805 Medium parameters used: $f = 711$ MHz; $\sigma = 0.937$ S/m; $\epsilon_r = 55.147$; $\rho = 1000$ kg/m³
Ambient Temperature : 23.2 °C; Liquid Temperature : 22.6 °C

DASY5 Configuration:

- Probe: EX3DV4 - SN3819; ConvF(9.71, 9.71, 9.71); Calibrated: 2013.11.27;
- Sensor-Surface: 2mm (Mechanical Surface Detection)
- Electronics: DAE3 Sn569; Calibrated: 2013.11.22
- Phantom: SAM2; Type: QD000P40CD; Serial: TP:1671
- Measurement SW: DASY52, Version 52.8 (7); SEMCAD X Version 14.6.10 (7164)

Ch23130/Area Scan (71x131x1): Interpolated grid: dx=15mm, dy=15mm

Maximum value of SAR (interpolated) = 0.425 W/kg

Ch23130/Zoom Scan (5x5x7)/Cube 0: Measurement grid: dx=8mm, dy=8mm, dz=5mm

Reference Value = 4.607 V/m; Power Drift = 0.05 dB

Peak SAR (extrapolated) = 0.466 W/kg

SAR(1 g) = 0.364 W/kg; SAR(10 g) = 0.277 W/kg

Maximum value of SAR (measured) = 0.419 W/kg

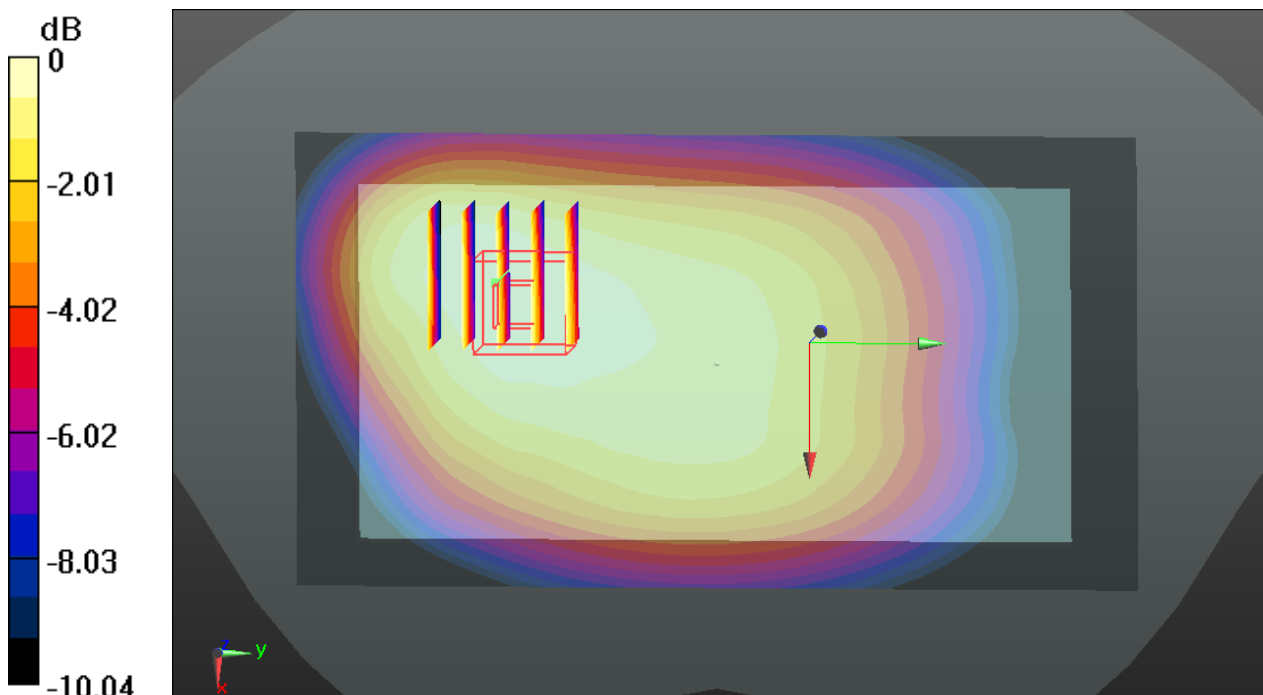

0 dB = 0.419 W/kg

19_LTE Band 17_10M_QPSK_1RB_49offset_Front_1cm_Ch23780

Communication System: UID 0, LTE (0); Frequency: 709 MHz; Duty Cycle: 1:1
 Medium: MSL_750_140805 Medium parameters used: $f = 709$ MHz; $\sigma = 0.934$ S/m; $\epsilon_r = 55.166$; $\rho = 1000$ kg/m³
 Ambient Temperature : 23.2 °C; Liquid Temperature : 22.6 °C

DASY5 Configuration:

- Probe: EX3DV4 - SN3819; ConvF(9.71, 9.71, 9.71); Calibrated: 2013.11.27;
- Sensor-Surface: 2mm (Mechanical Surface Detection)
- Electronics: DAE3 Sn569; Calibrated: 2013.11.22
- Phantom: SAM2; Type: QD000P40CD; Serial: TP:1671
- Measurement SW: DASY52, Version 52.8 (7); SEMCAD X Version 14.6.10 (7164)

Ch23780/Area Scan (71x131x1): Interpolated grid: dx=15mm, dy=15mm
 Maximum value of SAR (interpolated) = 0.410 W/kg

Ch23780/Zoom Scan (5x5x7)/Cube 0: Measurement grid: dx=8mm, dy=8mm, dz=5mm
 Reference Value = 4.519 V/m; Power Drift = 0.01 dB
 Peak SAR (extrapolated) = 0.445 W/kg
SAR(1 g) = 0.349 W/kg; SAR(10 g) = 0.266 W/kg
 Maximum value of SAR (measured) = 0.401 W/kg

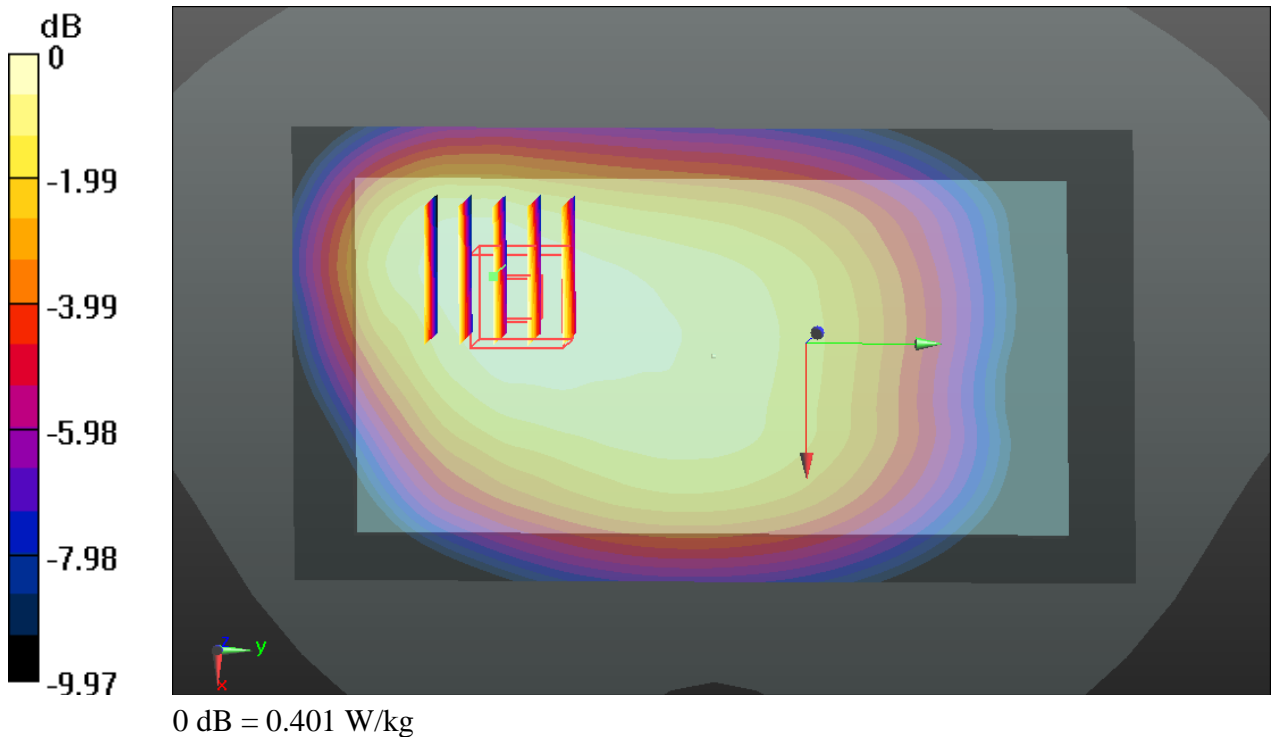

20_LTE Band 5_10M_QPSK_1RB_24offset_Front_1cm_Ch20600

Communication System: UID 0, LTE (0); Frequency: 844 MHz; Duty Cycle: 1:1
Medium: MSL_835_140805 Medium parameters used: $f = 844$ MHz; $\sigma = 0.985$ S/m; $\epsilon_r = 54.324$; $\rho = 1000$ kg/m³
Ambient Temperature : 23.2 °C; Liquid Temperature : 22.6 °C

DASY5 Configuration:

- Probe: EX3DV4 - SN3819; ConvF(9.54, 9.54, 9.54); Calibrated: 2013.11.27;
- Sensor-Surface: 2mm (Mechanical Surface Detection)
- Electronics: DAE3 Sn569; Calibrated: 2013.11.22
- Phantom: SAM2; Type: QD000P40CD; Serial: TP:1671
- Measurement SW: DASY52, Version 52.8 (7); SEMCAD X Version 14.6.10 (7164)

Ch20600/Area Scan (71x131x1): Interpolated grid: dx=15mm, dy=15mm

Maximum value of SAR (interpolated) = 0.317 W/kg

Ch20600/Zoom Scan (5x5x7)/Cube 0: Measurement grid: dx=8mm, dy=8mm, dz=5mm

Reference Value = 3.664 V/m; Power Drift = 0.06 dB

Peak SAR (extrapolated) = 0.352 W/kg

SAR(1 g) = 0.264 W/kg; SAR(10 g) = 0.191 W/kg

Maximum value of SAR (measured) = 0.314 W/kg

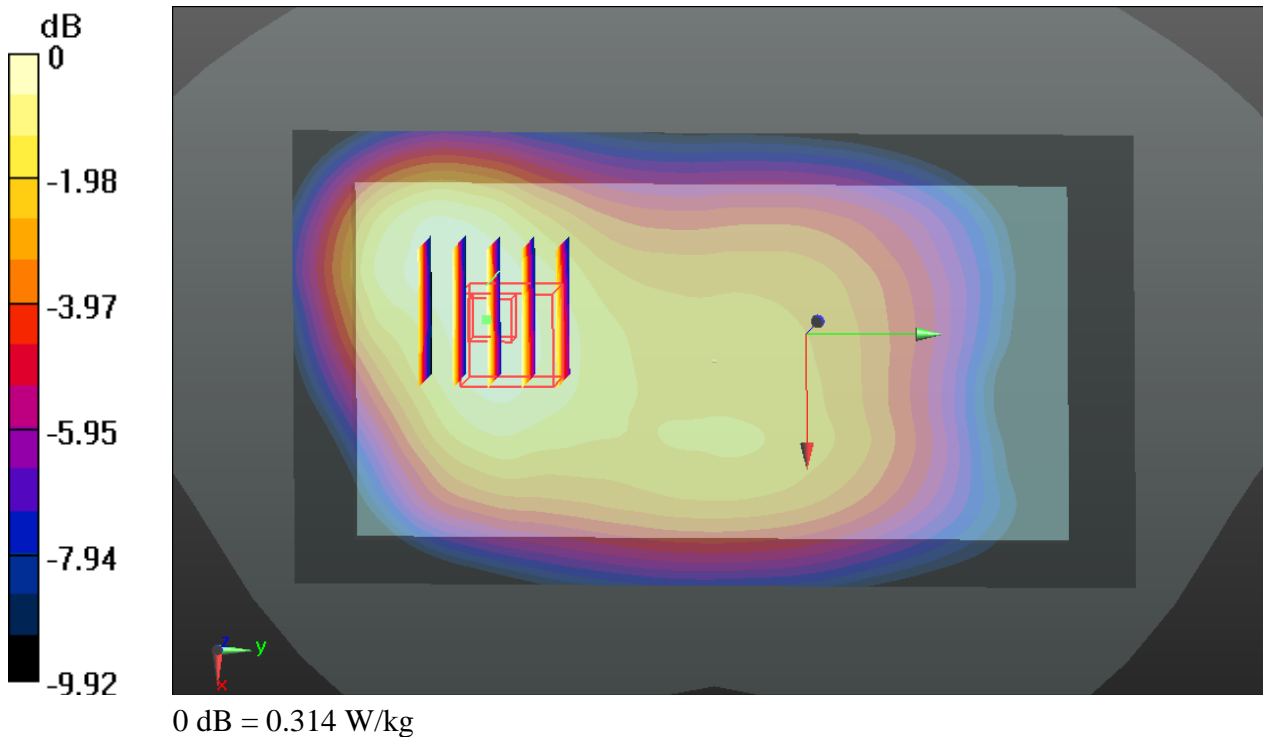

21_LTE Band 26_15M_QPSK_1RB_74offset_Front_1cm_Ch26765

Communication System: UID 0, LTE (0); Frequency: 821.5 MHz; Duty Cycle: 1:1
Medium: MSL_835_140805 Medium parameters used: $f = 821.5$ MHz; $\sigma = 0.964$ S/m; $\epsilon_r = 54.497$;
 $\rho = 1000$ kg/m³
Ambient Temperature : 23.2 °C; Liquid Temperature : 22.6 °C

DASY5 Configuration:

- Probe: EX3DV4 - SN3819; ConvF(9.54, 9.54, 9.54); Calibrated: 2013.11.27;
- Sensor-Surface: 2mm (Mechanical Surface Detection)
- Electronics: DAE3 Sn569; Calibrated: 2013.11.22
- Phantom: SAM2; Type: QD000P40CD; Serial: TP:1671
- Measurement SW: DASY52, Version 52.8 (7); SEMCAD X Version 14.6.10 (7164)

Ch26765/Area Scan (71x131x1): Interpolated grid: dx=15mm, dy=15mm

Maximum value of SAR (interpolated) = 0.323 W/kg

Ch26765/Zoom Scan (5x5x7)/Cube 0: Measurement grid: dx=8mm, dy=8mm, dz=5mm

Reference Value = 3.865 V/m; Power Drift = 0.05 dB

Peak SAR (extrapolated) = 0.359 W/kg

SAR(1 g) = 0.268 W/kg; SAR(10 g) = 0.194 W/kg

Maximum value of SAR (measured) = 0.322 W/kg

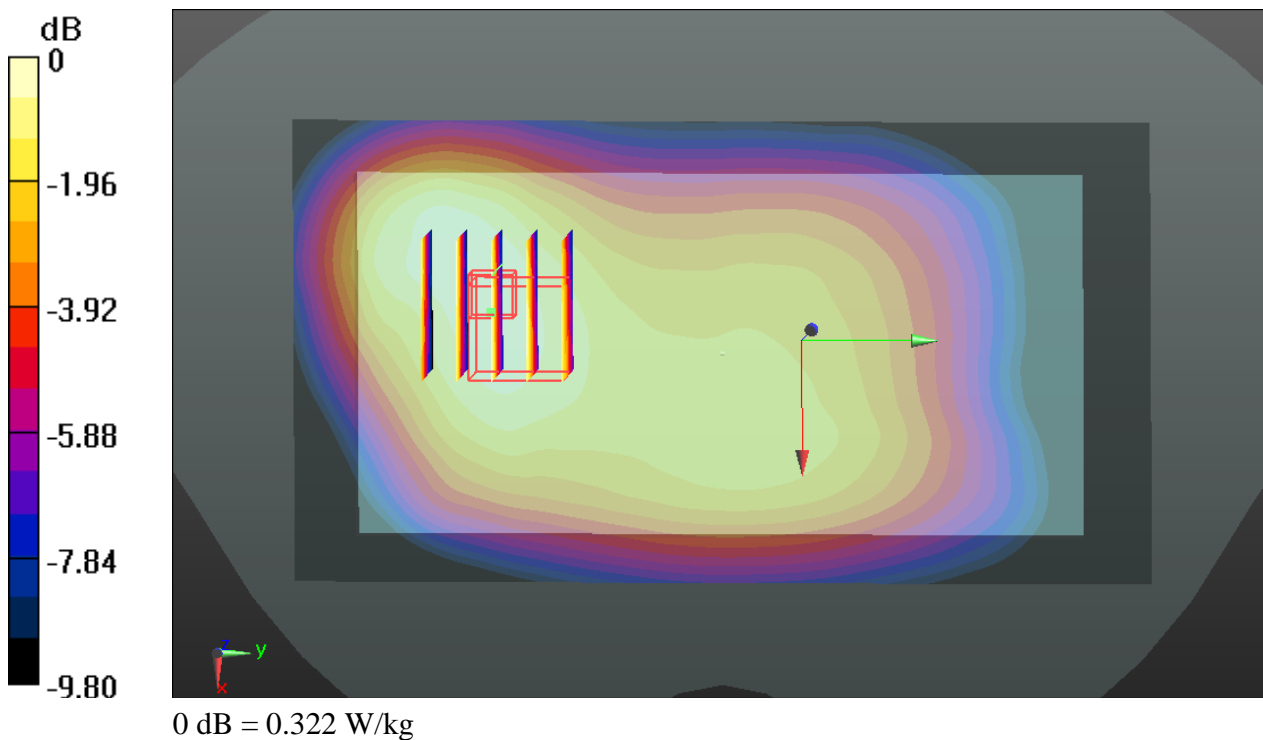

22_LTE Band 4_20M_QPSK_1RB_49offset_Bottom Side_1cm_Ch20300

Communication System: UID 0, LTE (0); Frequency: 1745 MHz; Duty Cycle: 1:1
 Medium: MSL_1800_140803 Medium parameters used: $f = 1745$ MHz; $\sigma = 1.523$ S/m; $\epsilon_r = 52.051$;
 $\rho = 1000$ kg/m³
 Ambient Temperature : 23.4 °C; Liquid Temperature : 22.7 °C

DASY5 Configuration:

- Probe: EX3DV4 - SN3819; ConvF(8.01, 8.01, 8.01); Calibrated: 2013.11.27;
- Sensor-Surface: 2mm (Mechanical Surface Detection)
- Electronics: DAE3 Sn569; Calibrated: 2013.11.22
- Phantom: SAM2; Type: QD000P40CD; Serial: TP:1671
- Measurement SW: DASY52, Version 52.8 (7); SEMCAD X Version 14.6.10 (7164)

Ch20300/Area Scan (41x81x1): Interpolated grid: dx=15mm, dy=15mm
 Maximum value of SAR (interpolated) = 0.923 W/kg

Ch20300/Zoom Scan (5x5x7)/Cube 0: Measurement grid: dx=8mm, dy=8mm, dz=5mm
 Reference Value = 4.643 V/m; Power Drift = -0.09 dB
 Peak SAR (extrapolated) = 1.20 W/kg
SAR(1 g) = 0.713 W/kg; SAR(10 g) = 0.386 W/kg
 Maximum value of SAR (measured) = 0.997 W/kg

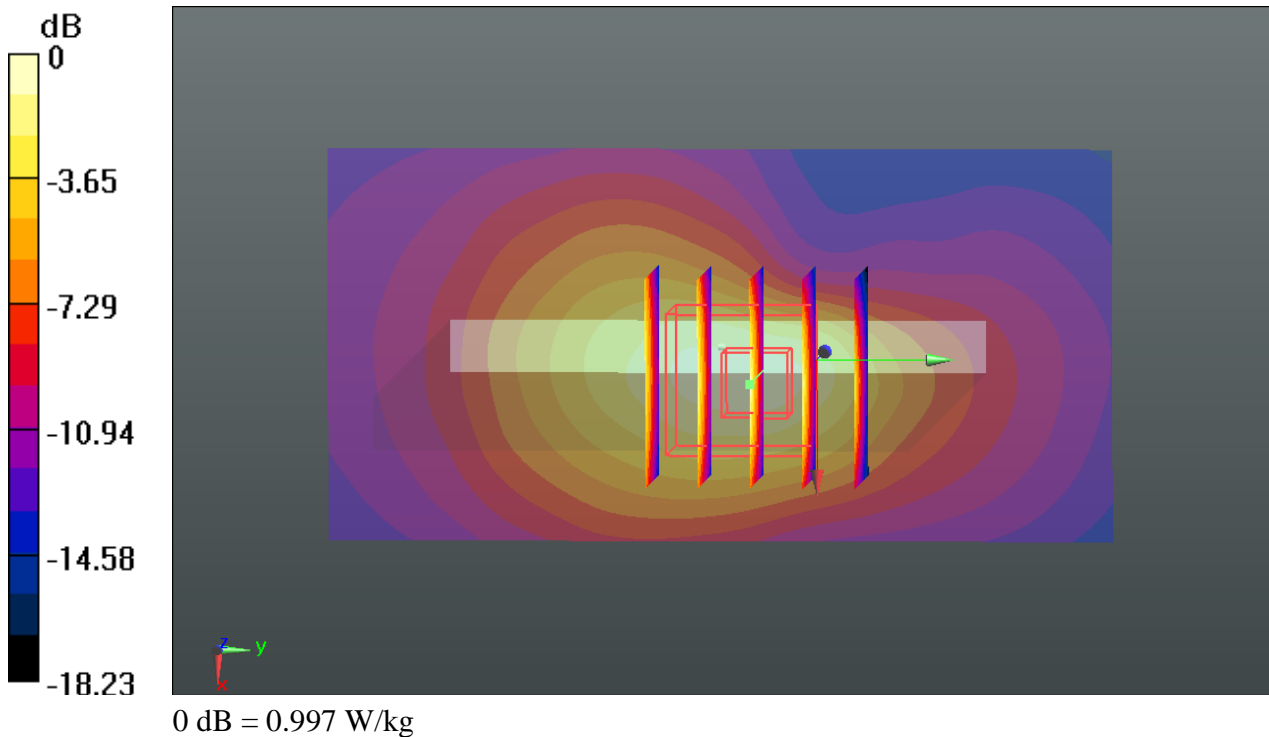

23_LTE Band 2_20M_QPSK_1RB_0offset_Bottom Side_1cm_Ch18700

Communication System: UID 0, LTE (0); Frequency: 1860 MHz; Duty Cycle: 1:1
Medium: MSL_1900_140803 Medium parameters used: $f = 1860$ MHz; $\sigma = 1.536$ S/m; $\epsilon_r = 54.355$;
 $\rho = 1000$ kg/m³
Ambient Temperature : 23.2 °C; Liquid Temperature : 22.7 °C

DASY5 Configuration:

- Probe: EX3DV4 - SN3819; ConvF(7.55, 7.55, 7.55); Calibrated: 2013.11.27;
- Sensor-Surface: 2mm (Mechanical Surface Detection)
- Electronics: DAE3 Sn569; Calibrated: 2013.11.22
- Phantom: SAM2; Type: QD000P40CD; Serial: TP:1671
- Measurement SW: DASY52, Version 52.8 (7); SEMCAD X Version 14.6.10 (7164)

Ch18700/Area Scan (41x81x1): Interpolated grid: dx=15mm, dy=15mm

Maximum value of SAR (interpolated) = 1.05 W/kg

Ch18700/Zoom Scan (5x5x7)/Cube 0: Measurement grid: dx=8mm, dy=8mm, dz=5mm

Reference Value = 4.869 V/m; Power Drift = 0.03 dB

Peak SAR (extrapolated) = 1.42 W/kg

SAR(1 g) = 0.820 W/kg; SAR(10 g) = 0.435 W/kg

Maximum value of SAR (measured) = 1.16 W/kg

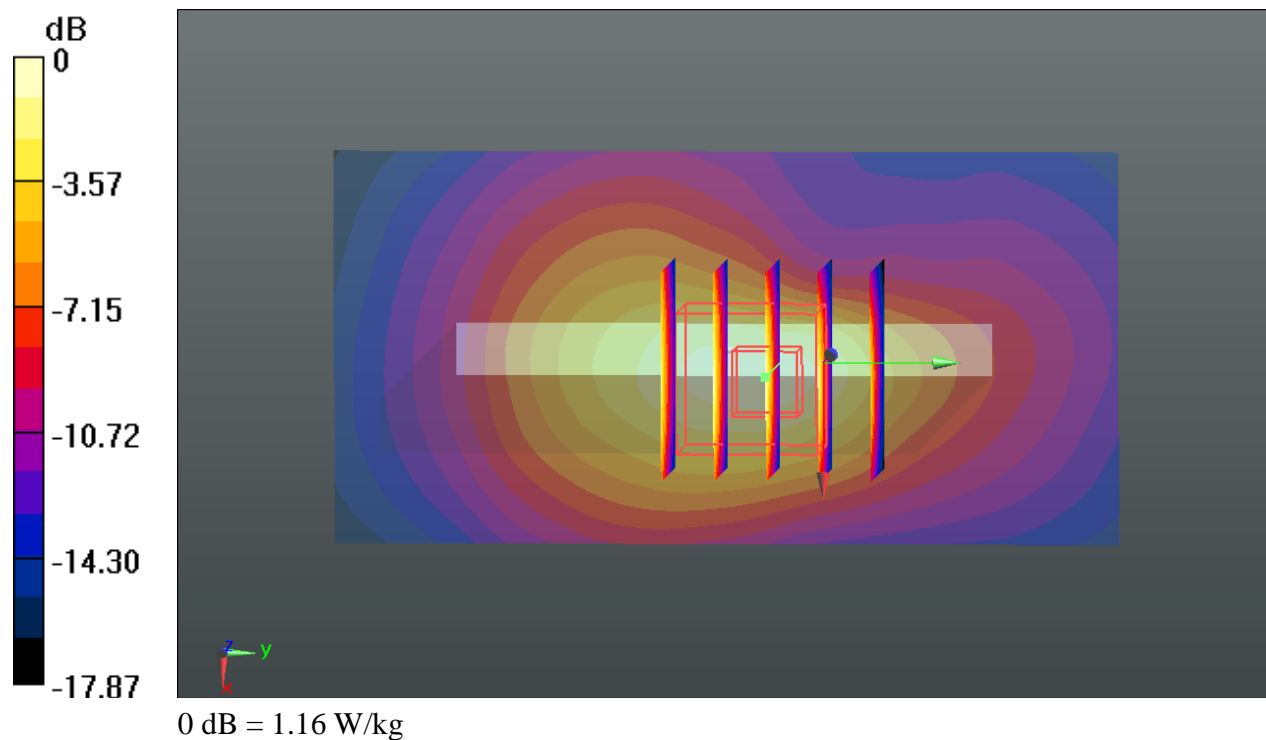

24_LTE Band 25_20M_QPSK_1RB_99offset_Bottom Side_1cm_Ch26340

Communication System: UID 0, LTE (0); Frequency: 1880 MHz; Duty Cycle: 1:1
Medium: MSL_1900_140803 Medium parameters used: $f = 1880$ MHz; $\sigma = 1.559$ S/m; $\epsilon_r = 54.281$;
 $\rho = 1000$ kg/m³
Ambient Temperature : 23.2 °C; Liquid Temperature : 22.7 °C

DASY5 Configuration:

- Probe: EX3DV4 - SN3819; ConvF(7.55, 7.55, 7.55); Calibrated: 2013.11.27;
- Sensor-Surface: 2mm (Mechanical Surface Detection)
- Electronics: DAE3 Sn569; Calibrated: 2013.11.22
- Phantom: SAM2; Type: QD000P40CD; Serial: TP:1671
- Measurement SW: DASY52, Version 52.8 (7); SEMCAD X Version 14.6.10 (7164)

Ch26340/Area Scan (41x81x1): Interpolated grid: dx=15mm, dy=15mm

Maximum value of SAR (interpolated) = 1.17 W/kg

Ch26340/Zoom Scan (5x5x7)/Cube 0: Measurement grid: dx=8mm, dy=8mm, dz=5mm

Reference Value = 5.042 V/m; Power Drift = 0.01 dB

Peak SAR (extrapolated) = 1.63 W/kg

SAR(1 g) = 0.928 W/kg; SAR(10 g) = 0.486 W/kg

Maximum value of SAR (measured) = 1.32 W/kg

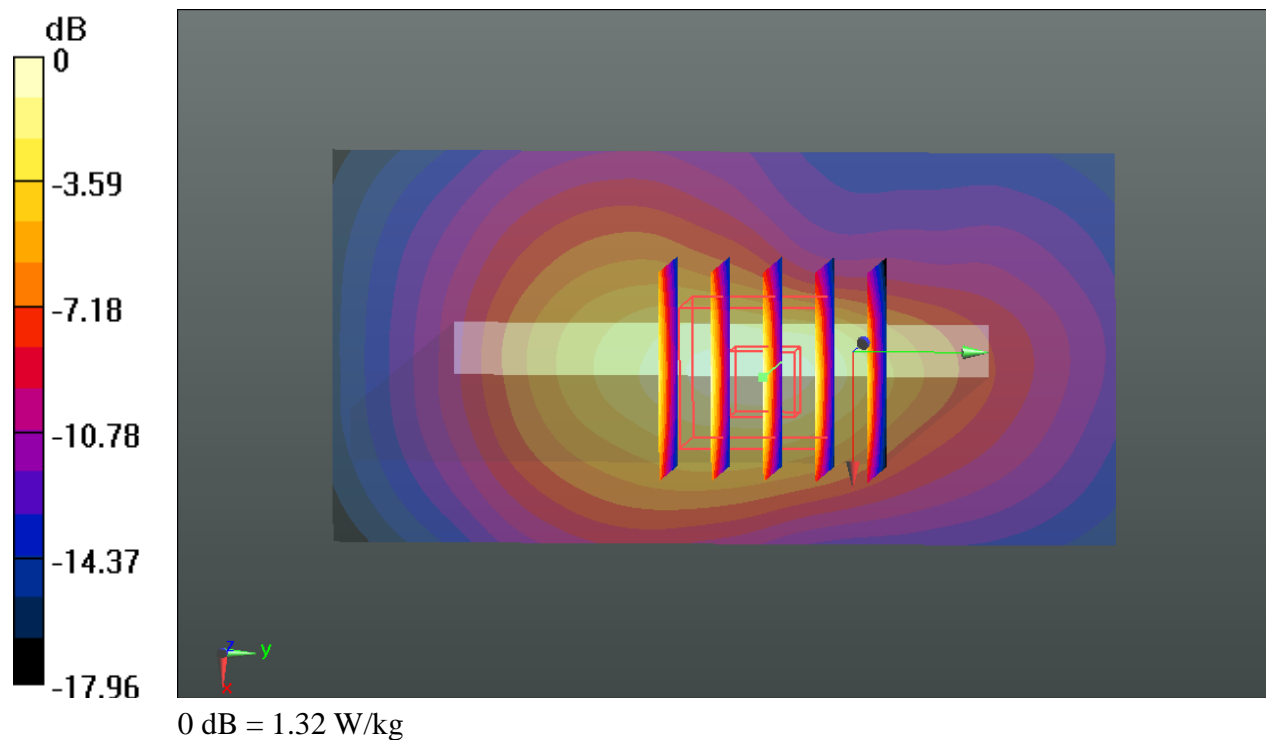

25_LTE Band 7_20M_QPSK_1RB_49offset_Bottom Side_1cm_Ch20850

Communication System: UID 0, LTE (0); Frequency: 2510 MHz; Duty Cycle: 1:1
Medium: MSL_2600_140804 Medium parameters used: $f = 2510$ MHz; $\sigma = 2.113$ S/m; $\epsilon_r = 51.294$;
 $\rho = 1000$ kg/m³
Ambient Temperature : 23.5 °C; Liquid Temperature : 22.8 °C

DASY5 Configuration:

- Probe: EX3DV4 - SN3819; ConvF(6.79, 6.79, 6.79); Calibrated: 2013.11.27;
- Sensor-Surface: 2mm (Mechanical Surface Detection)
- Electronics: DAE3 Sn569; Calibrated: 2013.11.22
- Phantom: SAM2; Type: QD000P40CD; Serial: TP:1671
- Measurement SW: DASY52, Version 52.8 (7); SEMCAD X Version 14.6.10 (7164)

Ch20850/Area Scan (41x91x1): Interpolated grid: dx=12mm, dy=12mm

Maximum value of SAR (interpolated) = 2.02 W/kg

Ch20850/Zoom Scan (7x7x7)/Cube 0: Measurement grid: dx=5mm, dy=5mm, dz=5mm

Reference Value = 4.479 V/m; Power Drift = 0.03 dB

Peak SAR (extrapolated) = 2.56 W/kg

SAR(1 g) = 1.280 W/kg; SAR(10 g) = 0.614 W/kg

Maximum value of SAR (measured) = 1.96 W/kg

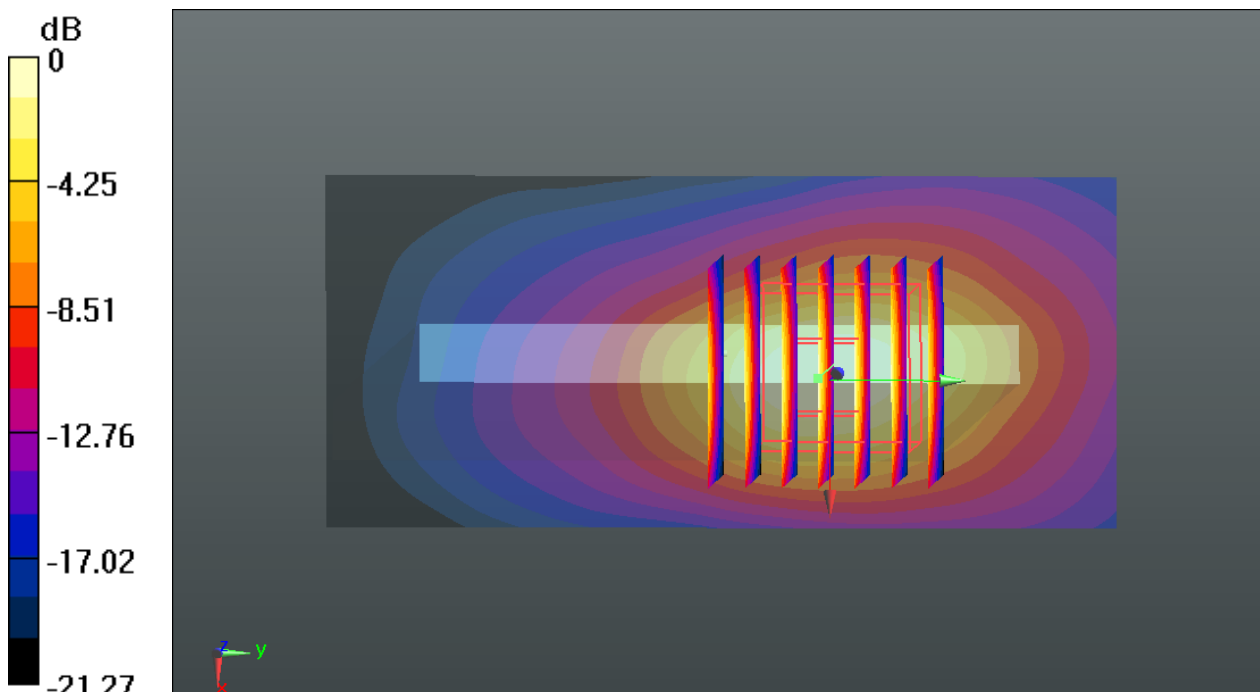

0 dB = 1.96 W/kg

26_WLAN2.4GHz_802.11b 1Mbps_Back_1cm_Ch11

Communication System: UID 0, WIFI (0); Frequency: 2462 MHz; Duty Cycle: 1:1.024
Medium: MSL_2450_140817 Medium parameters used: $f = 2462$ MHz; $\sigma = 2.029$ S/m; $\epsilon_r = 51.436$;
 $\rho = 1000$ kg/m³
Ambient Temperature : 23.3 °C; Liquid Temperature : 22.6 °C

DASY5 Configuration:

- Probe: EX3DV4 - SN3819; ConvF(7.07, 7.07, 7.07); Calibrated: 2013.11.27;
- Sensor-Surface: 2mm (Mechanical Surface Detection)
- Electronics: DAE3 Sn569; Calibrated: 2013.11.22
- Phantom: SAM1; Type: QD000P40CD; Serial: TP:1670
- Measurement SW: DASY52, Version 52.8 (7); SEMCAD X Version 14.6.10 (7164)

Ch11/Area Scan (91x161x1): Interpolated grid: dx=12mm, dy=12mm

Maximum value of SAR (interpolated) = 0.808 W/kg

Ch11/Zoom Scan (7x7x7)/Cube 0: Measurement grid: dx=5mm, dy=5mm, dz=5mm

Reference Value = 1.297 V/m; Power Drift = 0.03 dB

Peak SAR (extrapolated) = 1.12 W/kg

SAR(1 g) = 0.539 W/kg; SAR(10 g) = 0.240 W/kg

Maximum value of SAR (measured) = 0.812 W/kg

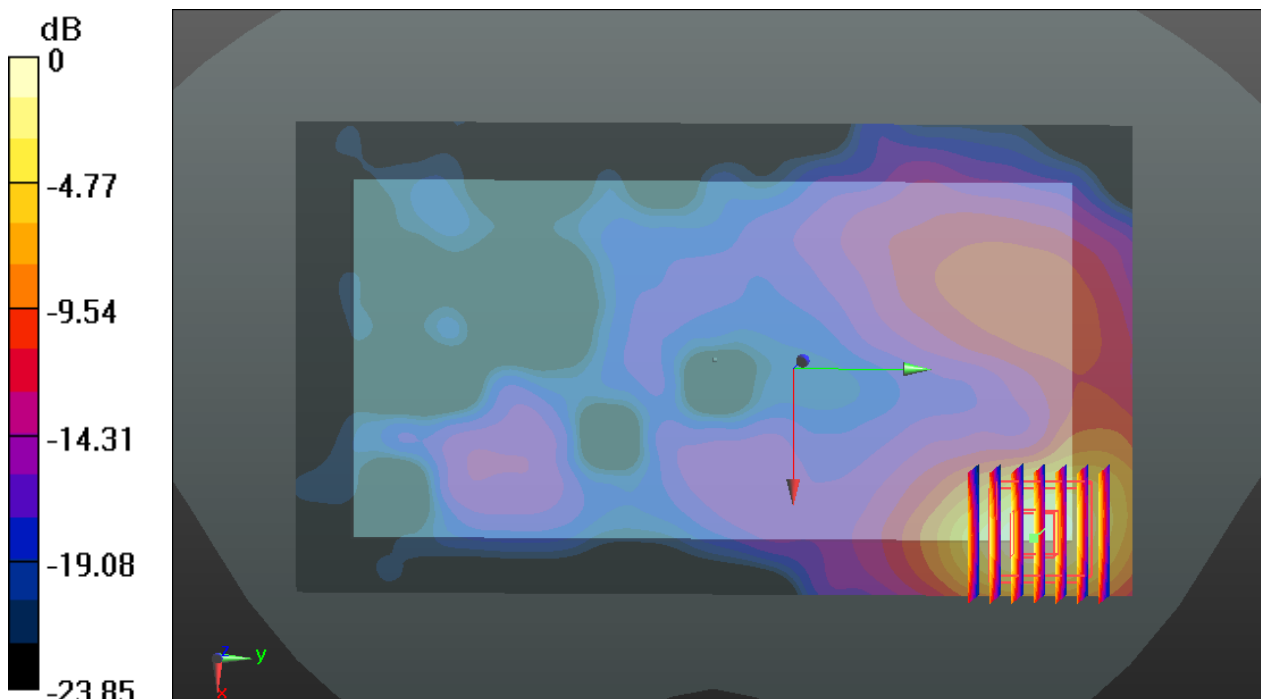

27_GSM1900_GPRS(2 Tx slots)_Back_1cm_Ch661

Communication System: UID 0, GPRS/EDGE10 (0); Frequency: 1880 MHz; Duty Cycle: 1:4.15
Medium: MSL_1900_140813 Medium parameters used: $f = 1880$ MHz; $\sigma = 1.521$ S/m; $\epsilon_r = 53.575$;
 $\rho = 1000$ kg/m³
Ambient Temperature : 23.2 °C; Liquid Temperature : 22.6 °C

DASY5 Configuration:

- Probe: EX3DV4 - SN3819; ConvF(7.55, 7.55, 7.55); Calibrated: 2013.11.27;
- Sensor-Surface: 2mm (Mechanical Surface Detection)
- Electronics: DAE3 Sn569; Calibrated: 2013.11.22
- Phantom: SAM2; Type: QD000P40CD; Serial: TP:1671
- Measurement SW: DASY52, Version 52.8 (7); SEMCAD X Version 14.6.10 (7164)

Ch661/Area Scan (71x131x1): Interpolated grid: dx=15mm, dy=15mm

Maximum value of SAR (interpolated) = 0.772 W/kg

Ch661/Zoom Scan (5x5x7)/Cube 0: Measurement grid: dx=8mm, dy=8mm, dz=5mm

Reference Value = 1.323 V/m; Power Drift = 0.03 dB

Peak SAR (extrapolated) = 0.942 W/kg

SAR(1 g) = 0.569 W/kg; SAR(10 g) = 0.334 W/kg

Maximum value of SAR (measured) = 0.757 W/kg

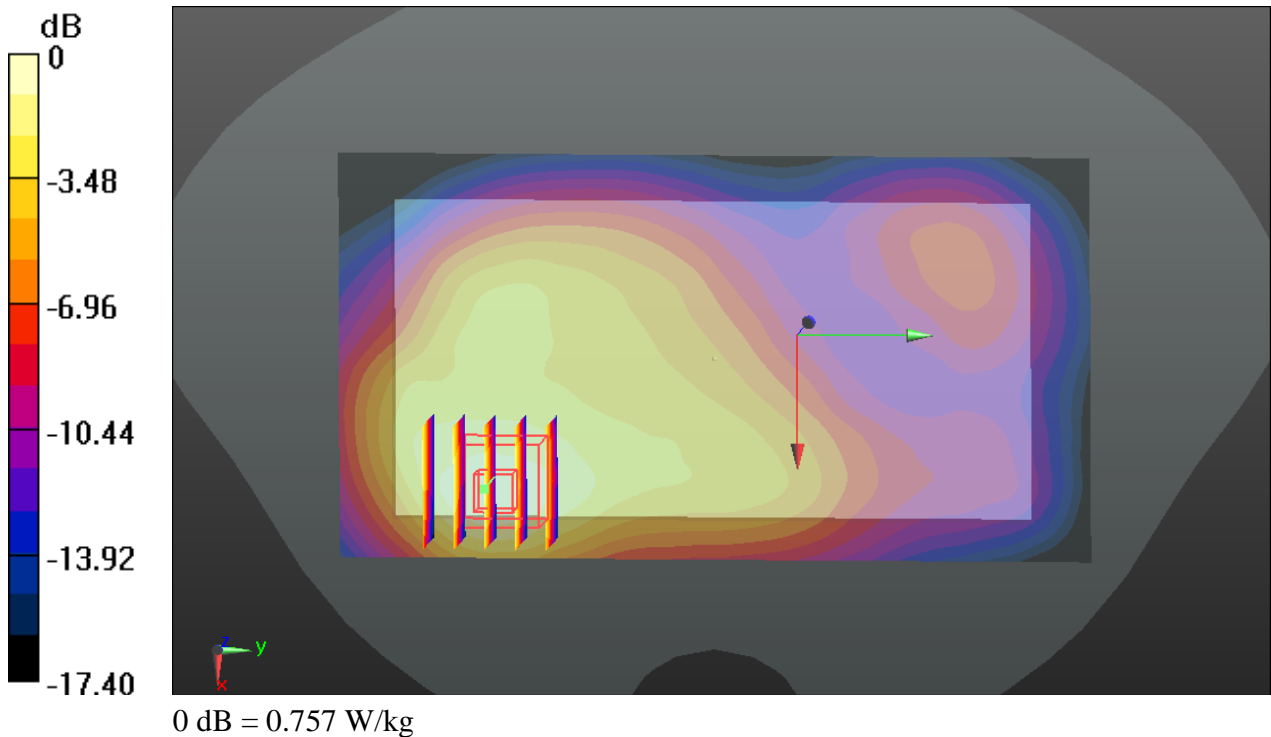

36_WCDMA Dcpf 'IV_RMC 12.2K_Back_1cm_Ch1513

Communication System: UID 0, UMTS (0); Frequency: 1752.6 MHz; Duty Cycle: 1:1
 Medium: MSL_1800_140827 Medium parameters used: $f = 175408$ MHz; $\sigma = 1.529$ S/m; $\epsilon_r = 52.612$;
 $\rho = 1000$ kg/m³
 Ambient Temperature : 23.4 °C; Liquid Temperature : 22.6 °C

DASY5 Configuration:

- Probe: EX3DV4 - SN3819; ConvF(8.01, 8.01, 8.01); Calibrated: 2013.11.27;
- Sensor-Surface: 2mm (Mechanical Surface Detection)
- Electronics: DAE4 Sn910; Calibrated: 2014.07.22
- Phantom: SAM2; Type: QD000P40CD; Serial: TP:1671
- Measurement SW: DASY52, Version 52.8 (7); SEMCAD X Version 14.6.10 (7164)

Ch1513/Area Scan (71x131x1): Interpolated grid: dx=15mm, dy=15mm

Maximum value of SAR (interpolated) = 0.698 W/kg

Ch1513/Zoom Scan (5x5x7)/Cube 0: Measurement grid: dx=8mm, dy=8mm, dz=5mm

Reference Value = 2.173 V/m; Power Drift = 0.05 dB

Peak SAR (extrapolated) = 0.858 W/kg

SAR(1 g) = 0.544 W/kg; SAR(10 g) = 0.325 W/kg

Maximum value of SAR (measured) = 0.700 W/kg

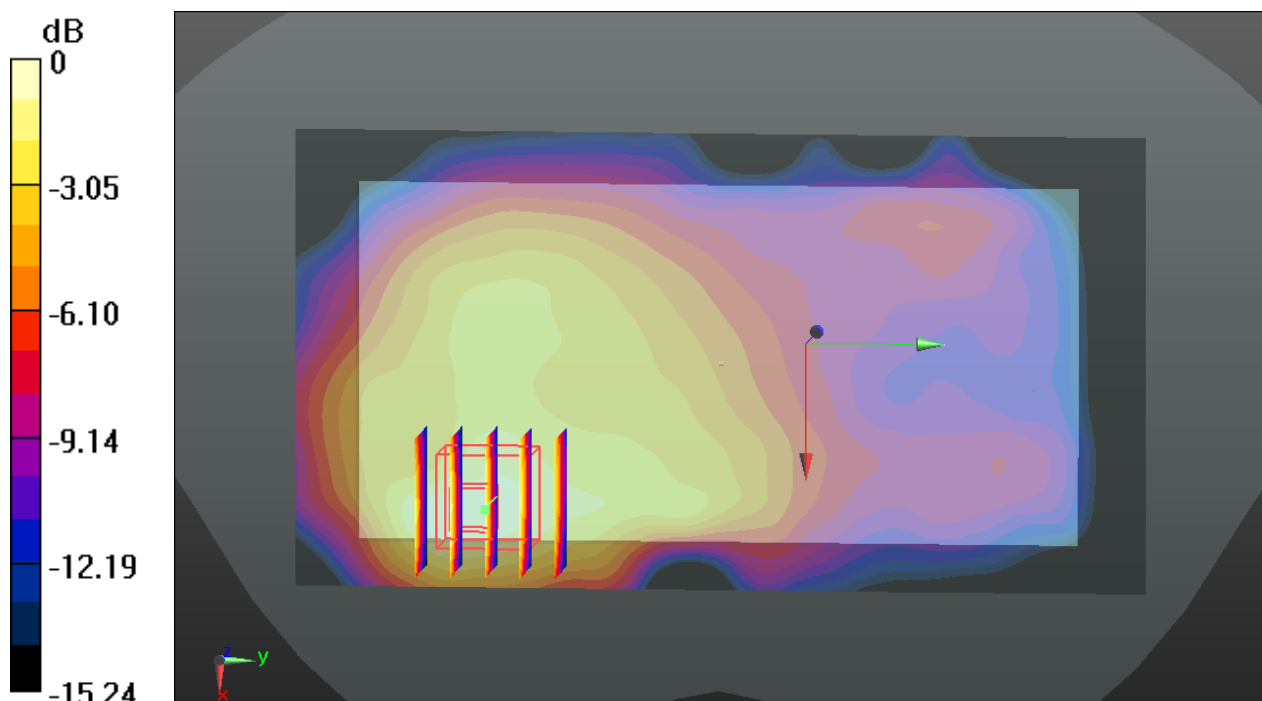

0 dB = 0.700 W/kg

28_WCDMA Band II_RMC 12.2K_Front_1cm_Ch9538

Communication System: UID 0, UMTS (0); Frequency: 1907.6 MHz; Duty Cycle: 1:1
Medium: MSL_1900_140803 Medium parameters used: $f = 190908$ MHz; $\sigma = 1.59$ S/m; $\epsilon_r = 54.182$; $\rho = 1000$ kg/m³
Ambient Temperature : 23.2 °C; Liquid Temperature : 22.7 °C

DASY5 Configuration:

- Probe: EX3DV4 - SN3819; ConvF(7.55, 7.55, 7.55); Calibrated: 2013.11.27;
- Sensor-Surface: 2mm (Mechanical Surface Detection)
- Electronics: DAE3 Sn569; Calibrated: 2013.11.22
- Phantom: SAM2; Type: QD000P40CD; Serial: TP:1671
- Measurement SW: DASY52, Version 52.8 (7); SEMCAD X Version 14.6.10 (7164)

Ch9538/Area Scan (71x131x1): Interpolated grid: dx=15mm, dy=15mm

Maximum value of SAR (interpolated) = 0.974 W/kg

Ch9538/Zoom Scan (5x5x7)/Cube 0: Measurement grid: dx=8mm, dy=8mm, dz=5mm

Reference Value = 4.792 V/m; Power Drift = -0.02 dB

Peak SAR (extrapolated) = 1.10 W/kg

SAR(1 g) = 0.705 W/kg; SAR(10 g) = 0.394 W/kg

Maximum value of SAR (measured) = 0.933 W/kg

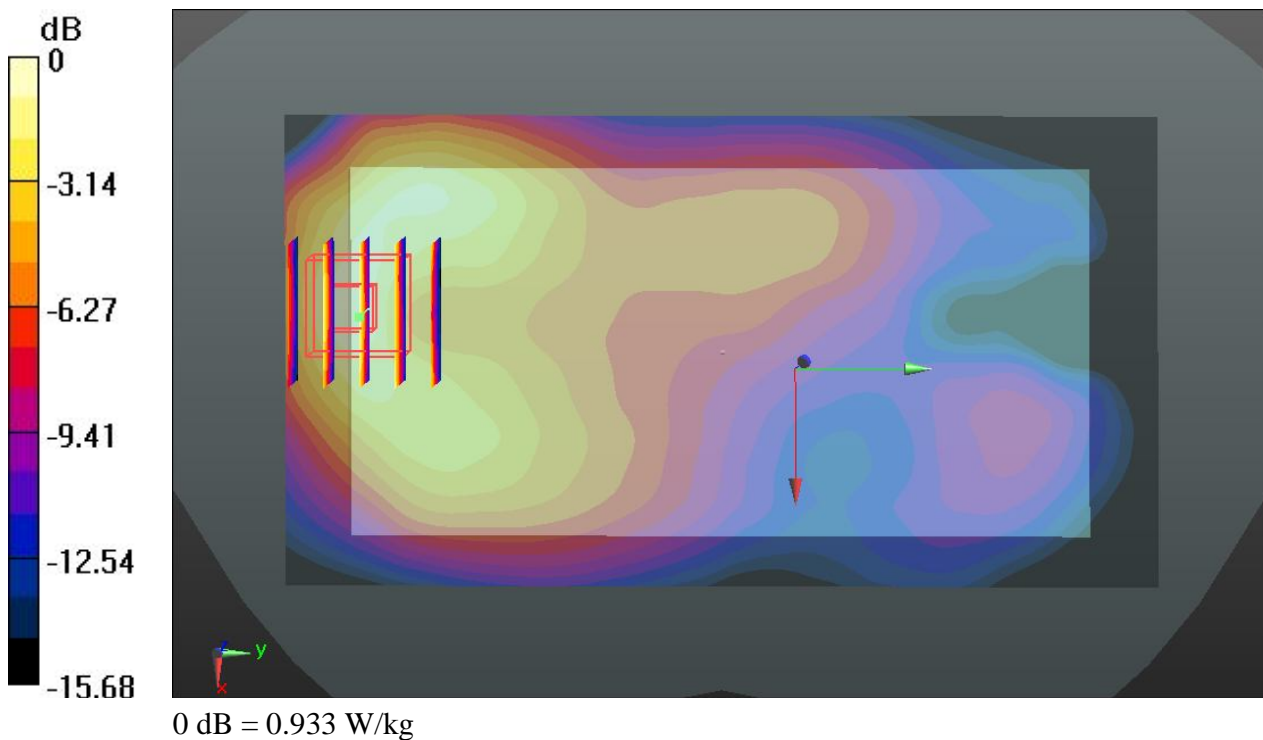

29_LTE Band 4_20M_QPSK_1RB_49offset_Back_1cm_Ch20300

Communication System: UID 0, LTE (0); Frequency: 1745 MHz; Duty Cycle: 1:1
 Medium: MSL_1800_140803 Medium parameters used: $f = 1745$ MHz; $\sigma = 1.523$ S/m; $\epsilon_r = 52.051$;
 $\rho = 1000$ kg/m³
 Ambient Temperature : 23.4 °C; Liquid Temperature : 22.7 °C

DASY5 Configuration:

- Probe: EX3DV4 - SN3819; ConvF(8.01, 8.01, 8.01); Calibrated: 2013.11.27;
- Sensor-Surface: 2mm (Mechanical Surface Detection)
- Electronics: DAE3 Sn569; Calibrated: 2013.11.22
- Phantom: SAM2; Type: QD000P40CD; Serial: TP:1671
- Measurement SW: DASY52, Version 52.8 (7); SEMCAD X Version 14.6.10 (7164)

Ch20300/Area Scan (71x131x1): Interpolated grid: dx=15mm, dy=15mm
 Maximum value of SAR (interpolated) = 0.919 W/kg

Ch20300/Zoom Scan (5x5x7)/Cube 0: Measurement grid: dx=8mm, dy=8mm, dz=5mm
 Reference Value = 2.559 V/m; Power Drift = 0.05 dB
 Peak SAR (extrapolated) = 1.09 W/kg
SAR(1 g) = 0.683 W/kg; SAR(10 g) = 0.408 W/kg
 Maximum value of SAR (measured) = 0.894 W/kg

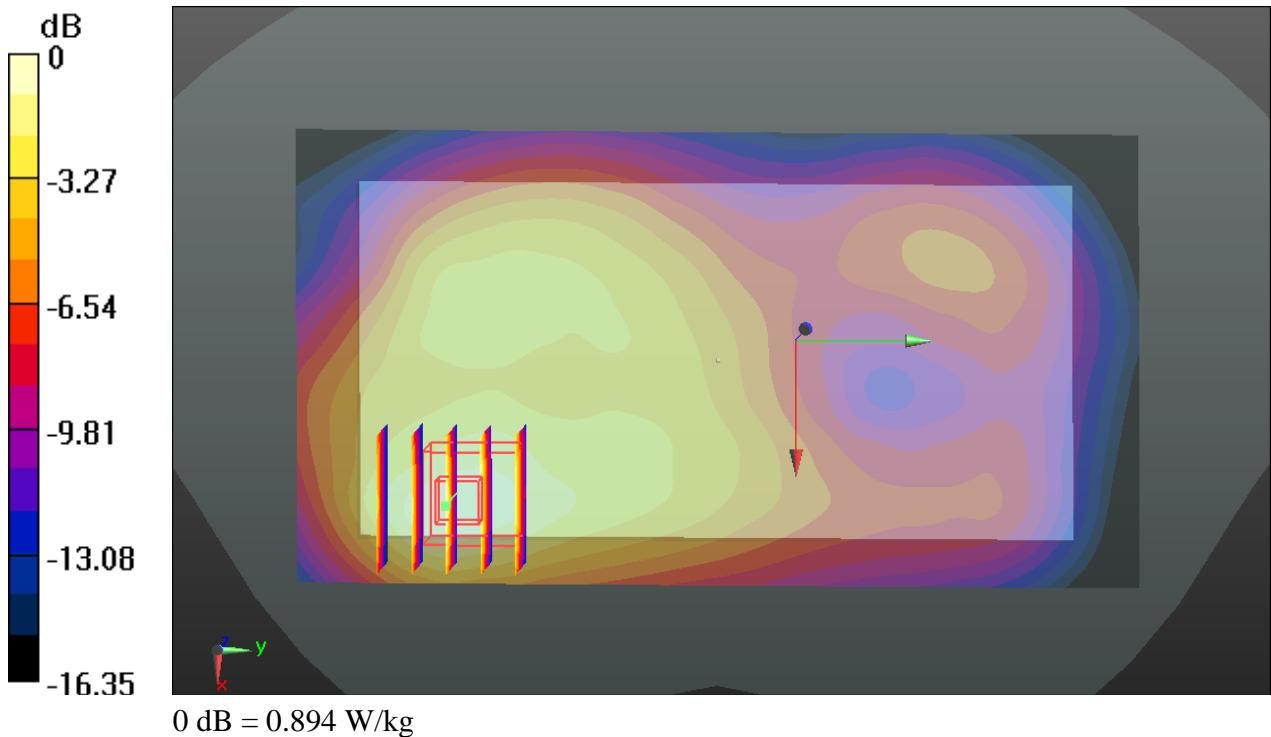

30_LTE Band 2_20M_QPSK_1RB_0offset_Front_1cm_Ch19100

Communication System: UID 0, LTE (0); Frequency: 1900 MHz; Duty Cycle: 1:1
Medium: MSL_1900_140803 Medium parameters used: $f = 1900$ MHz; $\sigma = 1.581$ S/m; $\epsilon_r = 54.208$;
 $\rho = 1000$ kg/m³
Ambient Temperature : 23.2 °C; Liquid Temperature : 22.7 °C

DASY5 Configuration:

- Probe: EX3DV4 - SN3819; ConvF(7.55, 7.55, 7.55); Calibrated: 2013.11.27;
- Sensor-Surface: 2mm (Mechanical Surface Detection)
- Electronics: DAE3 Sn569; Calibrated: 2013.11.22
- Phantom: SAM2; Type: QD000P40CD; Serial: TP:1671
- Measurement SW: DASY52, Version 52.8 (7); SEMCAD X Version 14.6.10 (7164)

Ch19100/Area Scan (71x131x1): Interpolated grid: dx=15mm, dy=15mm

Maximum value of SAR (interpolated) = 0.858 W/kg

Ch19100/Zoom Scan (5x5x7)/Cube 0: Measurement grid: dx=8mm, dy=8mm, dz=5mm

Reference Value = 4.253 V/m; Power Drift = 0.02 dB

Peak SAR (extrapolated) = 0.965 W/kg

SAR(1 g) = 0.617 W/kg; SAR(10 g) = 0.347 W/kg

Maximum value of SAR (measured) = 0.821 W/kg

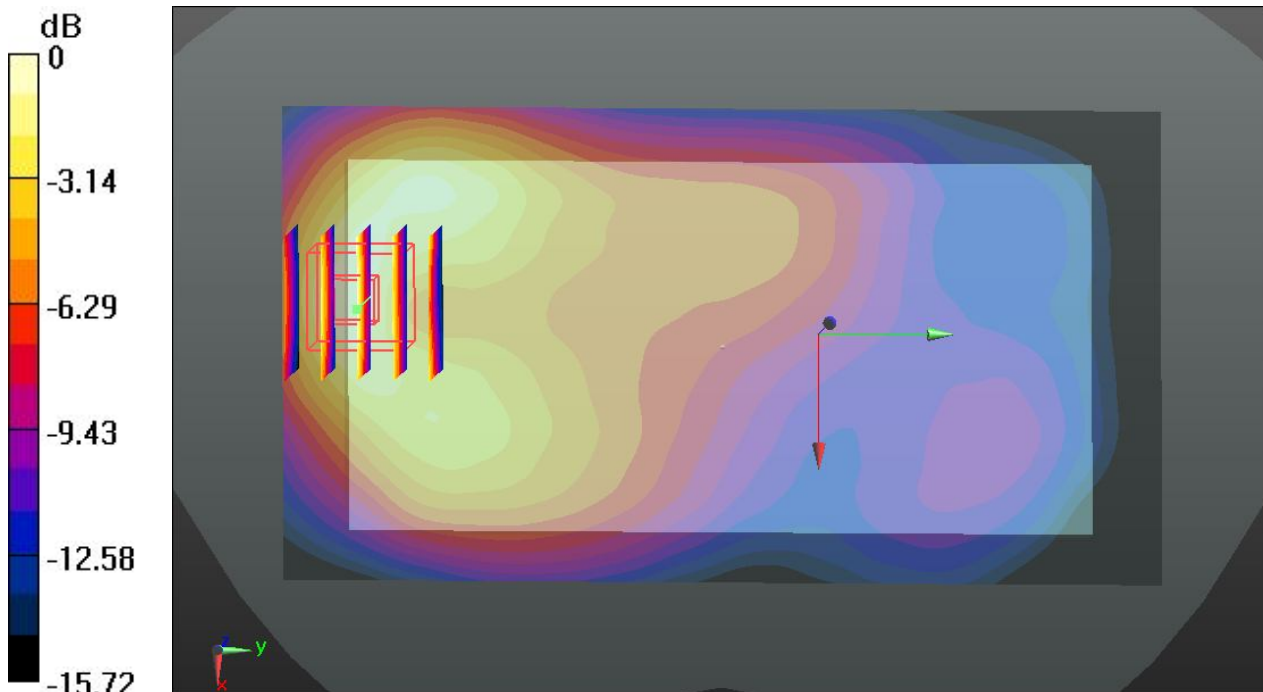

0 dB = 0.821 W/kg

31_LTE Band 25_20M_QPSK_1RB_99offset_Back_1cm_Ch26590

Communication System: UID 0, LTE (0); Frequency: 1905 MHz; Duty Cycle: 1:1
 Medium: MSL_1900_140803 Medium parameters used: $f = 1905$ MHz; $\sigma = 1.587$ S/m; $\epsilon_r = 54.191$;
 $\rho = 1000$ kg/m³
 Ambient Temperature : 23.2 °C; Liquid Temperature : 22.7 °C

DASY5 Configuration:

- Probe: EX3DV4 - SN3819; ConvF(7.55, 7.55, 7.55); Calibrated: 2013.11.27;
- Sensor-Surface: 2mm (Mechanical Surface Detection)
- Electronics: DAE3 Sn569; Calibrated: 2013.11.22
- Phantom: SAM2; Type: QD000P40CD; Serial: TP:1671
- Measurement SW: DASY52, Version 52.8 (7); SEMCAD X Version 14.6.10 (7164)

Ch26590/Area Scan (71x131x1): Interpolated grid: dx=15mm, dy=15mm
 Maximum value of SAR (interpolated) = 0.897 W/kg

Ch26590/Zoom Scan (5x5x7)/Cube 0: Measurement grid: dx=8mm, dy=8mm, dz=5mm
 Reference Value = 1.984 V/m; Power Drift = 0.07 dB
 Peak SAR (extrapolated) = 1.05 W/kg
SAR(1 g) = 0.640 W/kg; SAR(10 g) = 0.378 W/kg
 Maximum value of SAR (measured) = 0.853 W/kg

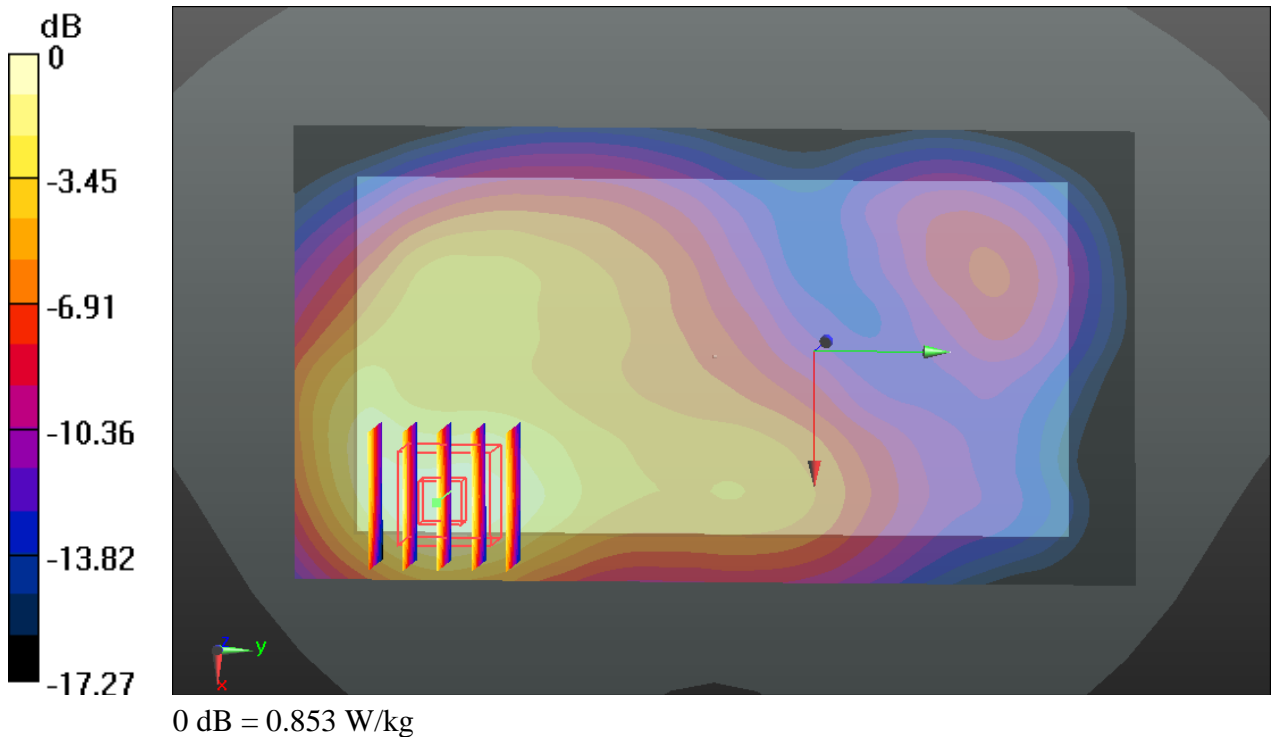

32_LTE Band 7_20M_QPSK_1RB_49offset_Back_1cm_Ch21350

Communication System: UID 0, LTE (0); Frequency: 2560 MHz; Duty Cycle: 1:1
Medium: MSL_2600_140804 Medium parameters used: $f = 2560$ MHz; $\sigma = 2.156$ S/m; $\epsilon_r = 51.082$;
 $\rho = 1000$ kg/m³
Ambient Temperature : 23.5 °C; Liquid Temperature : 22.8 °C

DASY5 Configuration:

- Probe: EX3DV4 - SN3819; ConvF(6.79, 6.79, 6.79); Calibrated: 2013.11.27;
- Sensor-Surface: 2mm (Mechanical Surface Detection)
- Electronics: DAE3 Sn569; Calibrated: 2013.11.22
- Phantom: SAM2; Type: QD000P40CD; Serial: TP:1671
- Measurement SW: DASY52, Version 52.8 (7); SEMCAD X Version 14.6.10 (7164)

Ch21350/Area Scan (91x161x1): Interpolated grid: dx=12mm, dy=12mm

Maximum value of SAR (interpolated) = 0.833 W/kg

Ch21350/Zoom Scan (7x7x7)/Cube 0: Measurement grid: dx=5mm, dy=5mm, dz=5mm

Reference Value = 1.071 V/m; Power Drift = 0.03 dB

Peak SAR (extrapolated) = 0.991 W/kg

SAR(1 g) = 0.558 W/kg; SAR(10 g) = 0.273 W/kg

Maximum value of SAR (measured) = 0.764 W/kg

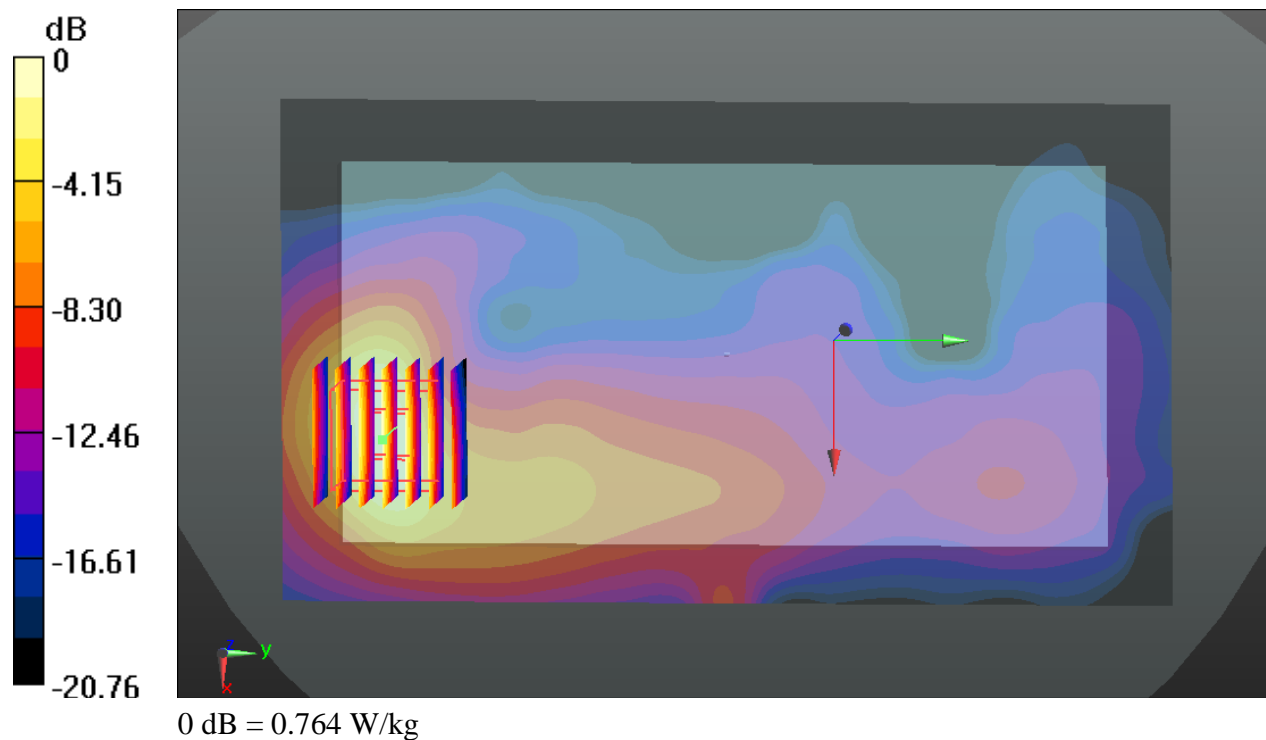

33_LTE Band 7_20M_QPSK_1RB_49offset_Bottom Side_0cm_Ch20850_Hand SAR

Communication System: UID 0, LTE (0); Frequency: 2510 MHz; Duty Cycle: 1:1
Medium: MSL_2600_140804 Medium parameters used: $f = 2510$ MHz; $\sigma = 2.113$ S/m; $\epsilon_r = 51.294$;
 $\rho = 1000$ kg/m³
Ambient Temperature : 23.5 °C; Liquid Temperature : 22.8 °C

DASY5 Configuration:

- Probe: EX3DV4 - SN3819; ConvF(6.79, 6.79, 6.79); Calibrated: 2013.11.27;
- Sensor-Surface: 2mm (Mechanical Surface Detection)
- Electronics: DAE3 Sn569; Calibrated: 2013.11.22
- Phantom: SAM2; Type: QD000P40CD; Serial: TP:1671
- Measurement SW: DASY52, Version 52.8 (7); SEMCAD X Version 14.6.10 (7164)

Ch20850/Area Scan (41x91x1): Interpolated grid: dx=12mm, dy=12mm

Maximum value of SAR (interpolated) = 0.868 W/kg

Ch20850/Zoom Scan (7x7x7)/Cube 0: Measurement grid: dx=5mm, dy=5mm, dz=5mm

Reference Value = 3.585 V/m; Power Drift = 0.02 dB

Peak SAR (extrapolated) = 1.48 W/kg

SAR(1 g) = 0.491 W/kg; SAR(10 g) = 0.211 W/kg

Maximum value of SAR (measured) = 0.868 W/kg

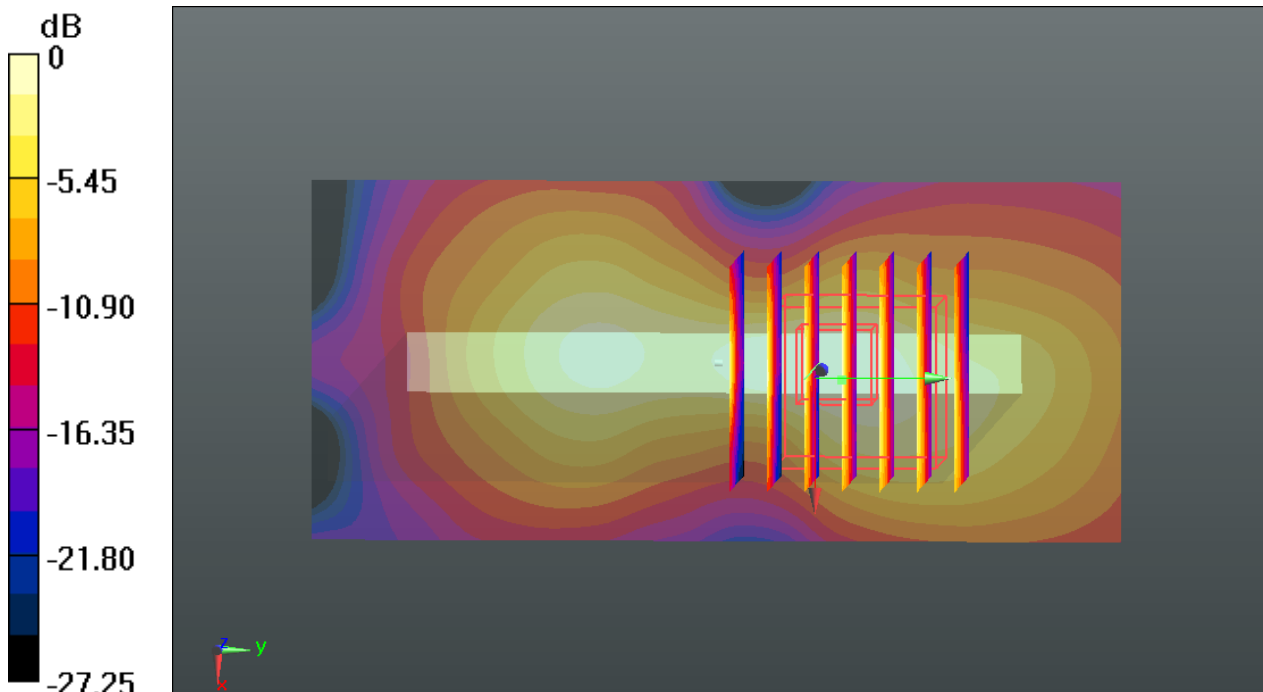

0 dB = 0.868 W/kg