



# FCC RF Test Report

**APPLICANT** : BYD Precision Manufacture Co., Ltd.  
**EQUIPMENT** : HP Slate 6 VoiceTab Plus  
**BRAND NAME** : HP  
**MODEL NAME** : HSTNH-B406M  
**FCC ID** : ZW9HSTNH-B406M  
**STANDARD** : FCC 47 CFR Part 2, and 90(S)  
**CLASSIFICATION** : PCS Licensed Transmitter Held to Ear (PCE)

The product was received on Jun. 09, 2014 and testing was completed on Aug. 24, 2014. We, SPORTON INTERNATIONAL (SHENZHEN) INC., would like to declare that the tested sample has been evaluated in accordance with the procedures given in ANSI / TIA / EIA-603-C-2004 and shown compliance with the applicable technical standards.

The test results in this report apply exclusively to the tested model / sample. Without written approval of SPORTON INTERNATIONAL (SHENZHEN) INC., the test report shall not be reproduced except in full.

---

Reviewed by: Joseph Lin / Supervisor

---

Approved by: Jones Tsai / Manager

**SPORTON INTERNATIONAL (SHENZHEN) INC.**

*No. 3 Building, the third floor of south, Shahe River west, Fengzeyuan warehouse, Nanshan District, Shenzhen, Guangdong, P.R.C.*



## TABLE OF CONTENTS

**REVISION HISTORY..... 3**

**SUMMARY OF TEST RESULT ..... 4**

**1 GENERAL DESCRIPTION ..... 5**

    1.1 Applicant..... 5

    1.2 Manufacturer ..... 5

    1.3 Feature of Equipment Under Test..... 5

    1.4 Product Specification of Equipment Under Test ..... 5

    1.5 Modification of EUT ..... 6

    1.6 Maximum Frequency Tolerance and Emission Designator ..... 6

    1.7 Testing Site ..... 7

    1.8 Applied Standards ..... 7

**2 TEST CONFIGURATION OF EQUIPMENT UNDER TEST ..... 8**

    2.1 Test Mode..... 8

    2.2 Connection Diagram of Test System ..... 9

    2.3 Support Unit used in test configuration and system..... 9

    2.4 Measurement Results Explanation Example ..... 10

**3 TEST RESULT..... 11**

    3.1 Conducted Output Power Measurement..... 11

    3.2 99% Occupied Bandwidth and 26dB Bandwidth Measurement..... 14

    3.3 Emissions Mask Measurement ..... 24

    3.4 Emissions Mask – Out Of Band Emissions Measurement..... 41

    3.5 Field Strength of Spurious Radiation Measurement ..... 52

    3.6 Frequency Stability Measurement..... 58

**4 LIST OF MEASURING EQUIPMENT ..... 61**

**5 UNCERTAINTY OF EVALUATION ..... 62**

**APPENDIX A. SETUP PHOTOGRAPHS**





### SUMMARY OF TEST RESULT

Report Section	FCC Rule	Description	Limit	Result	Remark
3.1	§2.1046	Conducted Output Power	N/A , Reporting only	PASS	-
3.2	§2.1049 §90.209	Occupied Bandwidth and 26dB Bandwidth	N/A, Reporting only	PASS	-
3.3	§2.1051 §90.691	Emission masks – In-band emissions	$< 50+10\log_{10}(P[\text{Watts}])$	PASS	-
3.4	§2.1051 §90.691	Emission masks – Out of band emissions	$< 43+10\log_{10}(P[\text{Watts}])$	PASS	-
3.5	§2.1053 §90.691	Field Strength of Spurious Radiation	$< 43+10\log_{10}(P[\text{Watts}])$	PASS	Under limit 35.50 dB at 1628.000MHz
3.6	§2.1055 §90.213	Frequency Stability for Temperature & Voltage	$< 2.5 \text{ ppm}$	PASS	-



# 1 General Description

## 1.1 Applicant

**BYD Precision Manufacture Co., Ltd.**

No.3001, Baohe Road, Baolong Industrial, Longgang, Shenzhen, P.R.China

## 1.2 Manufacturer

**Hewlett-Packard Company**

1501 Page Mill Road, Palo Alto, CA 94304, USA

## 1.3 Feature of Equipment Under Test

Product Feature & Specification	
<b>Equipment</b>	HP Slate 6 VoiceTab Plus
<b>Brand Name</b>	HP
<b>Model Name</b>	HSTNH-B406M
<b>FCC ID</b>	ZW9HSTNH-B406M
<b>EUT supports Radios application</b>	GSM/GPRS/EGPRS/WCDMA/HSPA/LTE/ WLAN 2.4GHz 802.11b/g/n HT20/ Bluetooth v3.0 +EDR/Bluetooth v4.0 LE
<b>HW Version</b>	MV
<b>SW Version</b>	V1.00.00
<b>EUT Stage</b>	Pre-Production

## 1.4 Product Specification of Equipment Under Test

Product Specification subjective to this standard	
<b>Tx Frequency</b>	LTE Band 26 : 814.7 ~ 823.3 MHz
<b>Rx Frequency</b>	LTE Band 26 : 859.7 ~ 868.3 MHz
<b>Bandwidth</b>	1.4MHz/3MHz/5MHz/10MHz
<b>Maximum Output Power to Antenna</b>	23.51 dBm
<b>Antenna Type</b>	Monopole Antenna
<b>Type of Modulation</b>	QPSK / 16QAM

**Remark:** This test report recorded only product characteristics and test results of PCS Licensed Transmitter Held to Ear (PCE).



### 1.5 Modification of EUT

No modifications are made to the EUT during all test items.

### 1.6 Maximum Frequency Tolerance and Emission Designator

FCC Rule	System	Type of Modulation	BW	Frequency Tolerance (ppm)	Emission Designator
Part 90S	LTE Band 26	QPSK	1.4 MHz	-	1M10G7D
Part 90S	LTE Band 26	16QAM	1.4 MHz	-	1M09W7D
Part 90S	LTE Band 26	QPSK	3 MHz	-	2M73G7D
Part 90S	LTE Band 26	16QAM	3 MHz	-	2M72W7D
Part 90S	LTE Band 26	QPSK	5 MHz	-	4M49G7D
Part 90S	LTE Band 26	16QAM	5 MHz	-	4M49W7D
Part 90S	LTE Band 26	QPSK	10 MHz	0.0232 ppm	9M06G7D
Part 90S	LTE Band 26	16QAM	10 MHz	-	8M97W7D

### 1.7 Testing Site

<b>Test Site</b>	SPORTON INTERNATIONAL (SHENZHEN) INC.	
<b>Test Site Location</b>	No. 3 Building, the third floor of south, Shahe River west, Fengzeyuan warehouse, Nanshan District, Shenzhen, Guangdong, P.R.C. TEL: +86-755-3320-2398	
<b>Test Site No.</b>	<b>Sporton Site No.</b>	<b>FCC Registration No.</b>
	TH01-SZ	831040

<b>Test Site</b>	SPORTON INTERNATIONAL (KUNSHAN) INC.	
<b>Test Site Location</b>	No. 3-2, PingXiang Road, Kunshan, Jiangsu Province, P.R.C. TEL: +86-0512-5790-0158 FAX: +86-0512-5790-0958	
<b>Test Site No.</b>	<b>Sporton Site No.</b>	<b>FCC Registration No.</b>
	03CH01-KS	149928

**Note:** The test site complies with ANSI C63.4 2003 requirement.

### 1.8 Applied Standards

According to the specifications of the manufacturer, the EUT must comply with the requirements of the following standards:

- ♦ Preliminary Guidance for Receiving Applications for Certification of 3G Device. May 9, 2006.
- ♦ FCC 47 CFR Part 2, 90(S)
- ♦ ANSI / TIA / EIA-603-C-2004

**Remark:**

1. All test items were verified and recorded according to the standards and without any deviation during the test.
2. This EUT has also been tested and complied with the requirements of FCC Part 15, Subpart B, recorded in a separate test report.



## 2 Test Configuration of Equipment Under Test

### 2.1 Test Mode

During all testing, EUT is in link mode with base station emulator at maximum power level. The spurious emission measurements were carried out in semi-anechoic chamber with 3-meter test range, and EUT is rotated on three test planes to find out the worst emission.

Test Items	Band	Bandwidth (MHz)						Modulation		RB #			Test Channel		
		1.4	3	5	10	15	20	QPSK	16QAM	1	Half	Full	L	M	H
Max. Output Power	26	v	v	v	v	-	-	v	v	v	v	v	v	v	v
26dB and 99% Bandwidth	26	v	v	v	v	-	-	v	v			v		v	
Conducted Band Edge	26	v	v	v	v	-	-	v	v	v		v	v		v
Conducted Spurious Emission	26	v	v	v	v	-	-	v	v	v			v	v	v
Frequency Stability	26				v	-	-	v				v		v	
Radiated Spurious Emission	26	v	v	v	v	-	-	v	v	v				v	
Note	<ol style="list-style-type: none"> <li>The mark "v" means that this configuration is chosen for testing</li> <li>The mark "-" means that this bandwidth is not supported.</li> <li>The device is investigated from 30MHz to 10 times of fundamental signal for radiated spurious emission test under different RB size/offset and modulations in exploratory test. Subsequently, only the worst case emissions are reported.</li> </ol>														



## 2.2 Connection Diagram of Test System

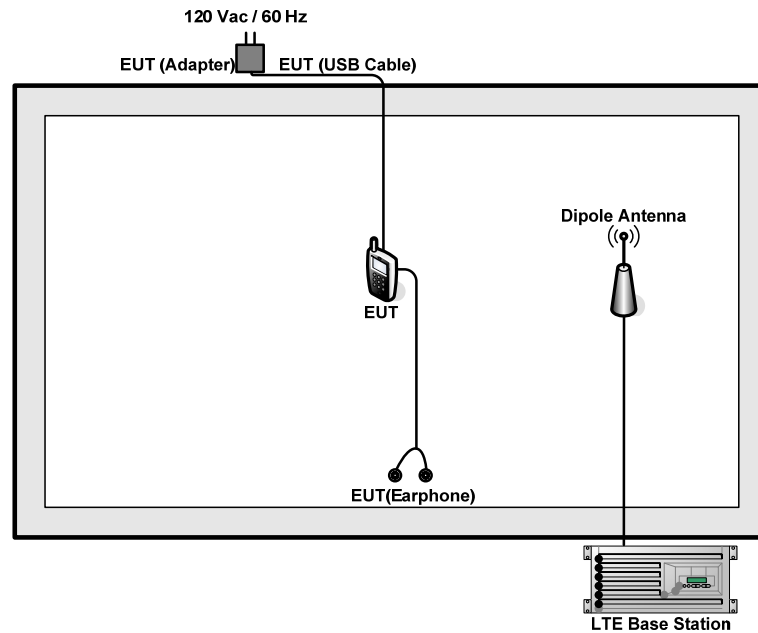

## 2.3 Support Unit used in test configuration and system

Item	Equipment	Trade Name	Model No.	FCC ID	Data Cable	Power Cord
1.	LTE Base Station	Anritsu	MT8820C	N/A	N/A	Unshielded, 1.8 m
2.	DC Power Supply	GWINSTEK	GPS-3030D	N/A	N/A	Unshielded, 1.8 m



## **2.4 Measurement Results Explanation Example**

**For all conducted test items:**

The offset level is set in the spectrum analyzer to compensate the RF cable loss and attenuator factor between EUT conducted output port and spectrum analyzer. With the offset compensation, the spectrum analyzer reading level is exactly the EUT RF output level.

Example:

The spectrum analyzer offset is derived from RF cable loss and attenuator factor.

*Offset = RF cable loss + attenuator factor.*

Following shows an offset computation example with cable loss 7 dB and 10dB attenuator.

$$\begin{aligned} \text{Offset(dB)} &= \text{RF cable loss(dB)} + \text{attenuator factor(dB)}. \\ &= 7 + 10 = 17 \text{ (dB)} \end{aligned}$$

### 3 Test Result

#### 3.1 Conducted Output Power Measurement

##### 3.1.1 Description of the Conducted Output Power Measurement

A base station simulator was used to establish communication with the EUT. Its parameters were set to transmit the maximum power on the EUT. The measured power in the radio frequency on the transmitter output terminals shall be reported.

##### 3.1.2 Measuring Instruments

The measuring equipment is listed in the section 4 of this test report.

##### 3.1.3 Test Procedures

1. The transmitter output port was connected to base station.
2. Set EUT at maximum power through base station.
3. Select lowest, middle, and highest channels for each band and different modulation.
4. Measure and record the power level from the system simulator.

##### 3.1.4 Test Setup

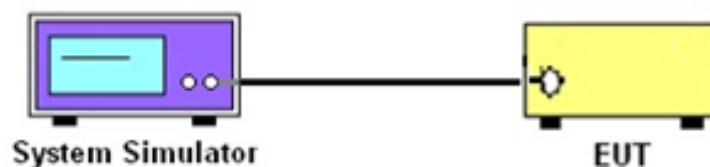

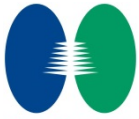

### 3.1.5 Test Result of Conducted Output Power

<LTE Band 26 Conducted Power>

BW [MHz]	Modulation	RB Size	RB Offset	Power (dBm) Low Ch. / Freq.	Power (dBm) Middle Ch. / Freq.	Power (dBm) High Ch. / Freq.
<b>Channel</b>					<b>26740</b>	
<b>Frequency (MHz)</b>					<b>819</b>	
10	QPSK	1	0		23.39	
10	QPSK	1	24		23.38	
10	QPSK	1	49		23.42	
10	QPSK	25	0		22.40	
10	QPSK	25	12		22.36	
10	QPSK	25	24		22.47	
10	QPSK	50	0		22.51	
10	16QAM	1	0		22.65	
10	16QAM	1	24		22.13	
10	16QAM	1	49		22.24	
10	16QAM	25	0		21.45	
10	16QAM	25	12		21.35	
10	16QAM	25	24		21.46	
10	16QAM	50	0		21.40	
<b>Channel</b>				<b>26715</b>	<b>26740</b>	<b>26765</b>
<b>Frequency (MHz)</b>				<b>816.5</b>	<b>819</b>	<b>821.5</b>
5	QPSK	1	0	23.37	23.51	23.24
5	QPSK	1	12	23.27	23.40	23.33
5	QPSK	1	24	23.30	23.47	23.28
5	QPSK	12	0	22.37	22.57	22.54
5	QPSK	12	6	22.43	22.56	22.47
5	QPSK	12	11	22.46	22.55	22.42
5	QPSK	25	0	22.42	22.49	22.42
5	16QAM	1	0	22.22	22.62	22.06
5	16QAM	1	12	22.15	22.15	22.61
5	16QAM	1	24	22.65	22.10	22.30
5	16QAM	12	0	21.55	21.53	21.39
5	16QAM	12	6	21.37	21.61	21.35
5	16QAM	12	11	21.44	21.42	21.33
5	16QAM	25	0	21.47	21.54	21.46

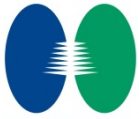

BW [MHz]	Modulation	RB Size	RB Offset	Power (dBm) Low Ch. / Freq.	Power (dBm) Middle Ch. / Freq.	Power (dBm) High Ch. / Freq.
<b>Channel</b>				<b>26705</b>	<b>26740</b>	<b>26775</b>
<b>Frequency (MHz)</b>				<b>815.5</b>	<b>819</b>	<b>822.5</b>
3	QPSK	1	0	23.40	23.35	23.26
3	QPSK	1	7	23.39	23.32	23.22
3	QPSK	1	14	23.37	23.46	23.40
3	QPSK	8	0	22.32	22.54	22.41
3	QPSK	8	4	22.49	22.45	22.44
3	QPSK	8	7	22.41	22.49	22.40
3	QPSK	15	0	22.44	22.46	22.46
3	16QAM	1	0	22.62	22.62	22.52
3	16QAM	1	7	22.21	22.55	22.17
3	16QAM	1	14	22.61	22.27	22.25
3	16QAM	8	0	21.55	21.38	21.49
3	16QAM	8	4	21.46	21.34	21.46
3	16QAM	8	7	21.51	21.60	21.46
3	16QAM	15	0	21.60	21.47	21.42
<b>Channel</b>				<b>26697</b>	<b>26740</b>	<b>26783</b>
<b>Frequency (MHz)</b>				<b>814.7</b>	<b>819</b>	<b>823.3</b>
1.4	QPSK	1	0	23.40	23.31	23.48
1.4	QPSK	1	2	23.34	23.40	23.33
1.4	QPSK	1	5	23.49	23.44	23.39
1.4	QPSK	3	0	23.44	23.43	23.42
1.4	QPSK	3	1	23.40	23.39	23.46
1.4	QPSK	3	2	23.45	23.40	23.47
1.4	QPSK	6	0	22.43	22.44	22.44
1.4	16QAM	1	0	22.37	22.11	22.32
1.4	16QAM	1	2	22.58	22.32	22.56
1.4	16QAM	1	5	22.06	22.53	22.20
1.4	16QAM	3	0	22.39	22.43	22.48
1.4	16QAM	3	1	22.39	22.29	22.37
1.4	16QAM	3	2	22.25	22.21	22.38
1.4	16QAM	6	0	21.42	21.34	21.17

**Note:** Maximum average power for LTE.

## 3.2 99% Occupied Bandwidth and 26dB Bandwidth Measurement

### 3.2.1 Description of (Occupied) Bandwidth Limitations Measurement

The 99% occupied bandwidth is the width of a frequency band such that, below the lower and above the upper frequency limits, the mean powers emitted are each equal to a specified percentage 0.5% of the total mean transmitted power.

The emission bandwidth is defined as the width of the signal between two points, located at the 2 sides of the carrier frequency, outside of which all emissions are attenuated at least 26 dB below the transmitter power.

### 3.2.2 Measuring Instruments

The measuring equipment is listed in the section 4 of this test report.

### 3.2.3 Test Procedures

1. The EUT was connected to Spectrum Analyzer and Base Station via power divider.
2. The 99% and 26 dB occupied bandwidth (BW) of the middle channel for the highest RF powers were measured.

### 3.2.4 Test Setup

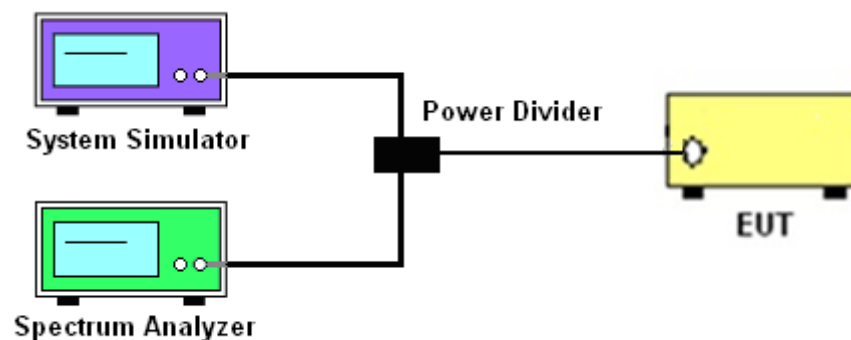



### 3.2.5 Test Result of 99% Occupied Bandwidth and 26dB Bandwidth

Modes	LTE Band 26			
BW / Mod.	1.4MHz / QPSK	1.4MHz / 16QAM	3MHz / QPSK	3MHz / 16QAM
99% OBW (MHz)	1.098	1.094	2.726	2.718
26dB BW (MHz)	1.293	1.289	3.039	3.048
BW / Mod.	5MHz / QPSK	5MHz / 16QAM	10MHz / QPSK	10MHz / 16QAM
99% OBW (MHz)	4.486	4.486	9.059	8.973
26dB BW (MHz)	5.022	5.022	9.986	9.986

**Note:**

The maximum RB configurations of the 99% Occupied Bandwidth and 26dB Bandwidth summary as below:

BW1.4MHz RB setting : RB Size 6, RB offset 0

BW3.0MHz RB setting : RB Size 15, RB offset 0

BW5.0MHz RB setting : RB Size 25, RB offset 0

BW10MHz RB setting : RB Size 50, RB offset 0



### 3.2.6 Test Result (Plots) of 99% Occupied Bandwidth and 26dB Bandwidth

Band :	LTE Band 26	BW / Mod. :	1.4MHz / QPSK
--------	-------------	-------------	---------------

99% Occupied Bandwidth Plot on Channel 26740

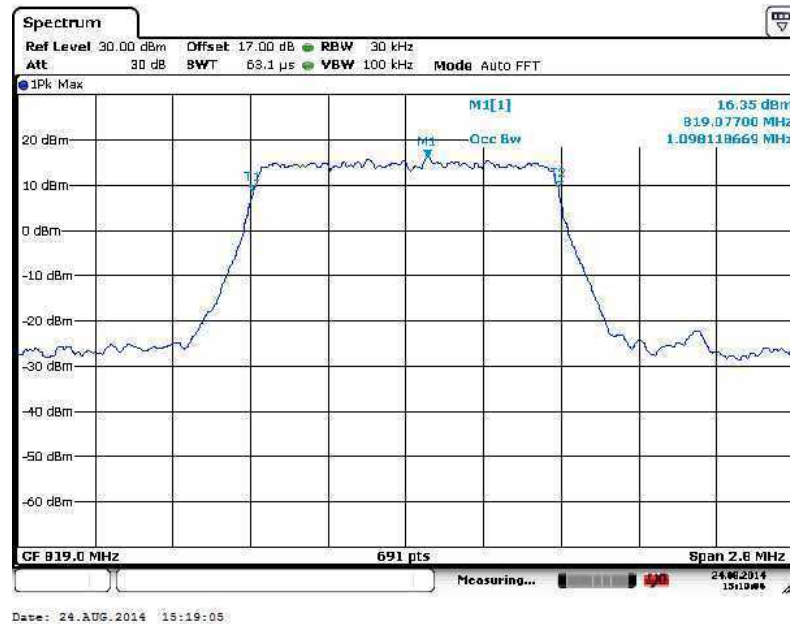

26dB Bandwidth Plot on Channel 26740

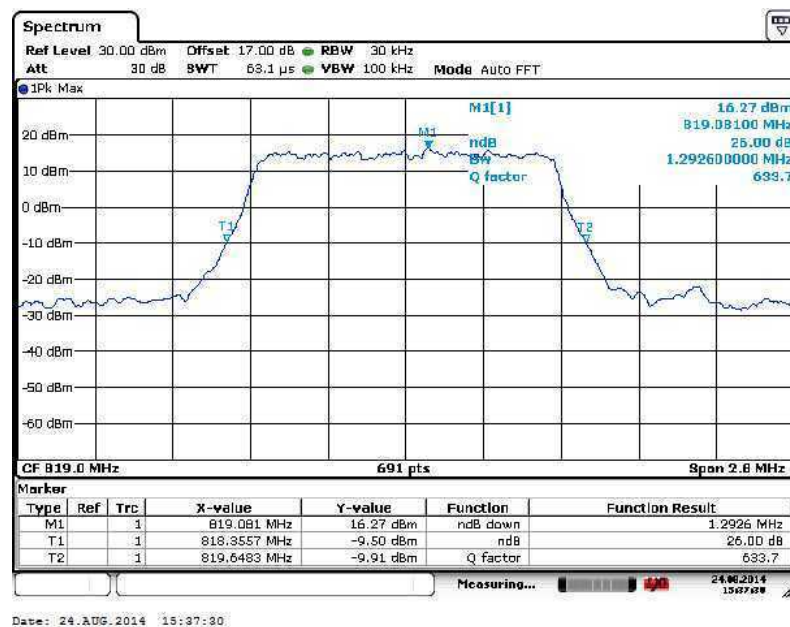



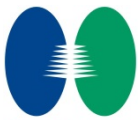

Band :	LTE Band 26	BW / Mod. :	1.4MHz / 16QAM
--------	-------------	-------------	----------------

99% Occupied Bandwidth Plot on Channel 26740

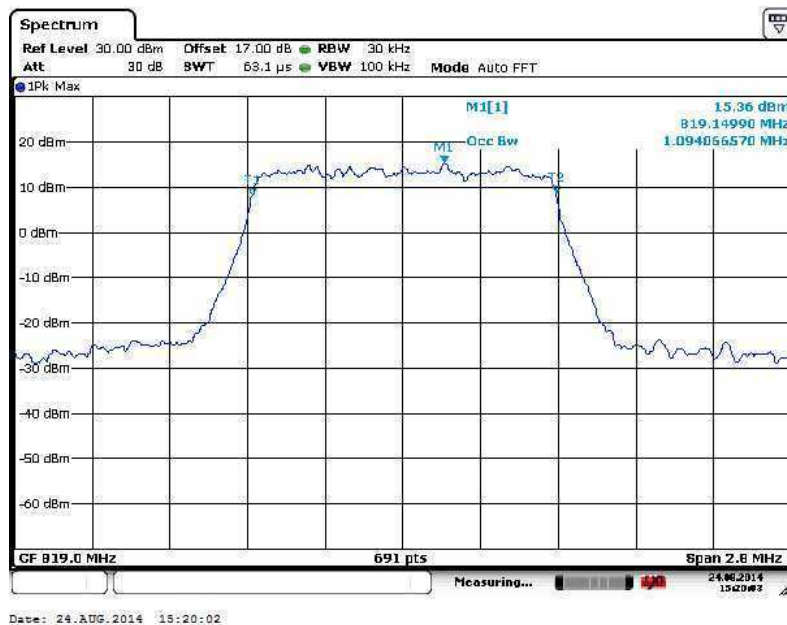

26dB Bandwidth Plot on Channel 26740

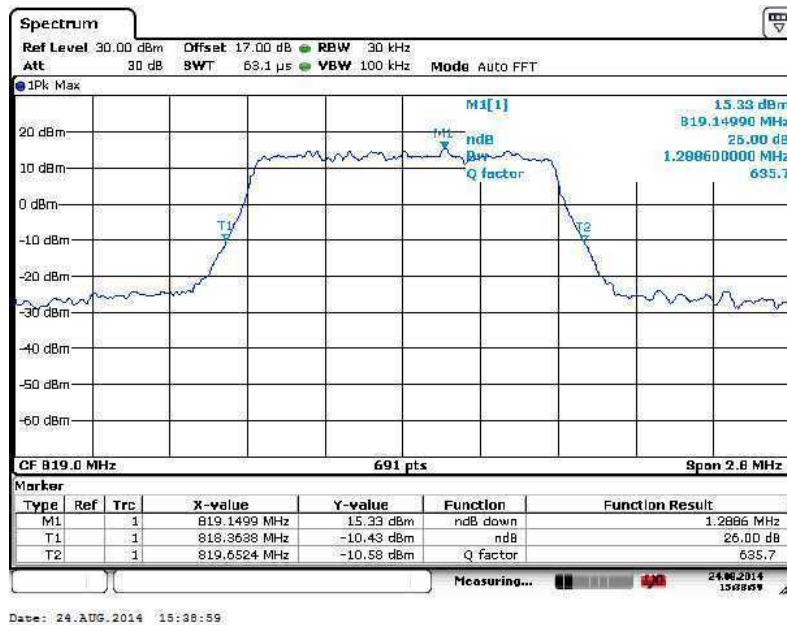



Band :	LTE Band 26	BW / Mod. :	3MHz / QPSK
--------	-------------	-------------	-------------

99% Occupied Bandwidth Plot on Channel 26740

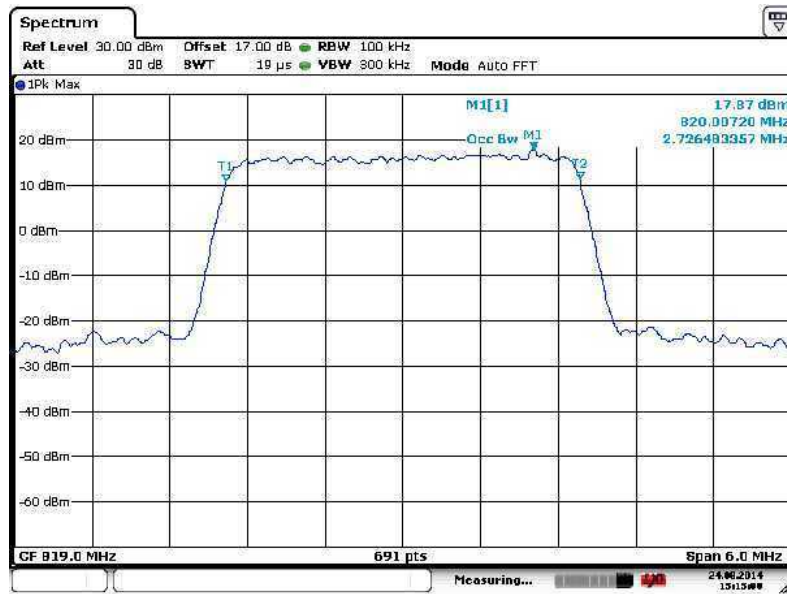

Date: 24.AUG.2014 15:15:00

26dB Bandwidth Plot on Channel 26740

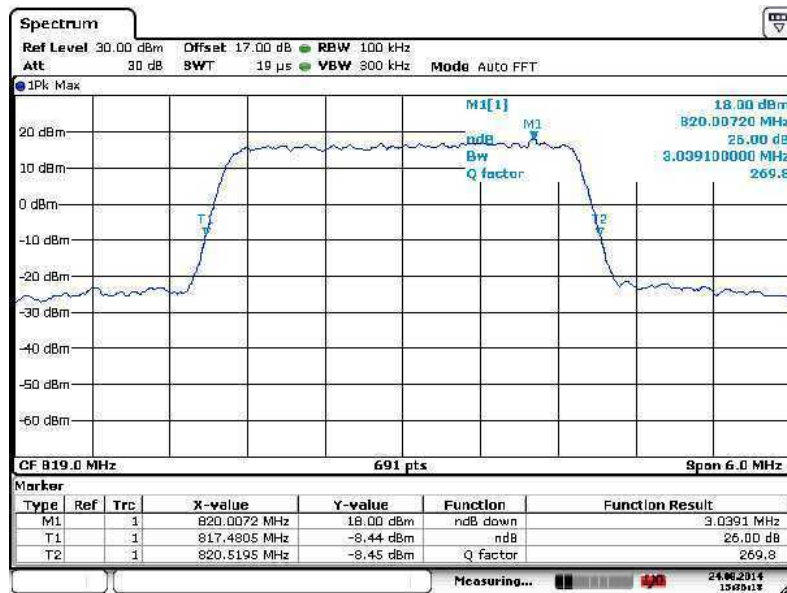

Date: 24.AUG.2014 15:16:18



Band :	LTE Band 26	BW / Mod. :	3MHz / 16QAM
--------	-------------	-------------	--------------

99% Occupied Bandwidth Plot on Channel 26740

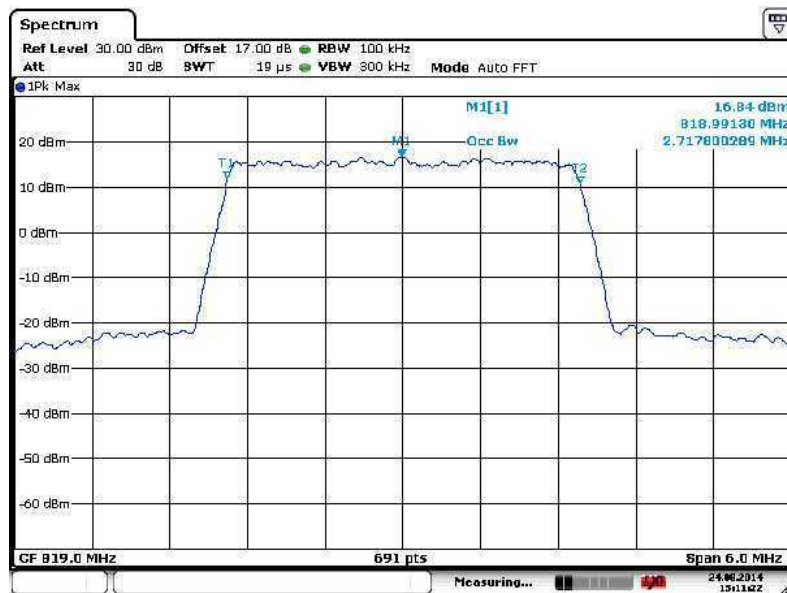

Date: 24.AUG.2014 15:11:22

26dB Bandwidth Plot on Channel 26740

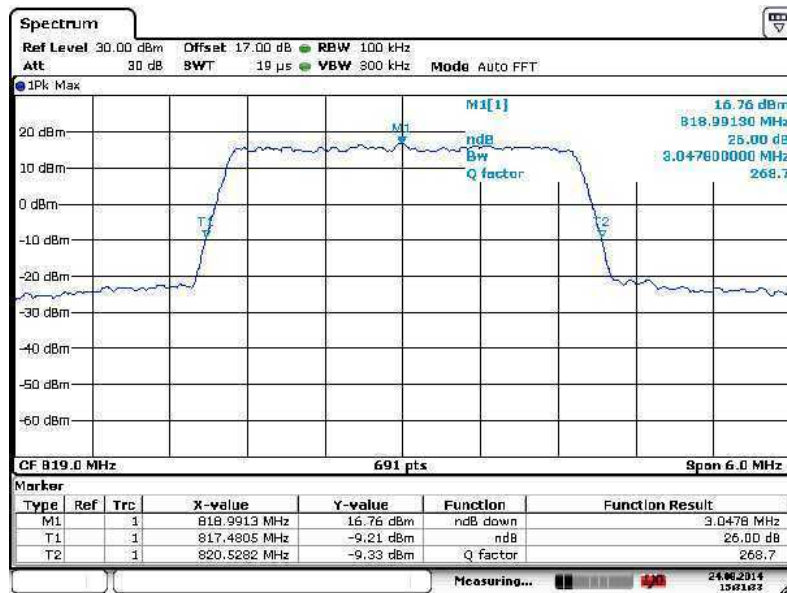

Date: 24.AUG.2014 15:11:33

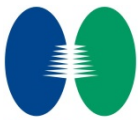

Band :	LTE Band 26	BW / Mod. :	5MHz / QPSK
--------	-------------	-------------	-------------

99% Occupied Bandwidth Plot on Channel 26740

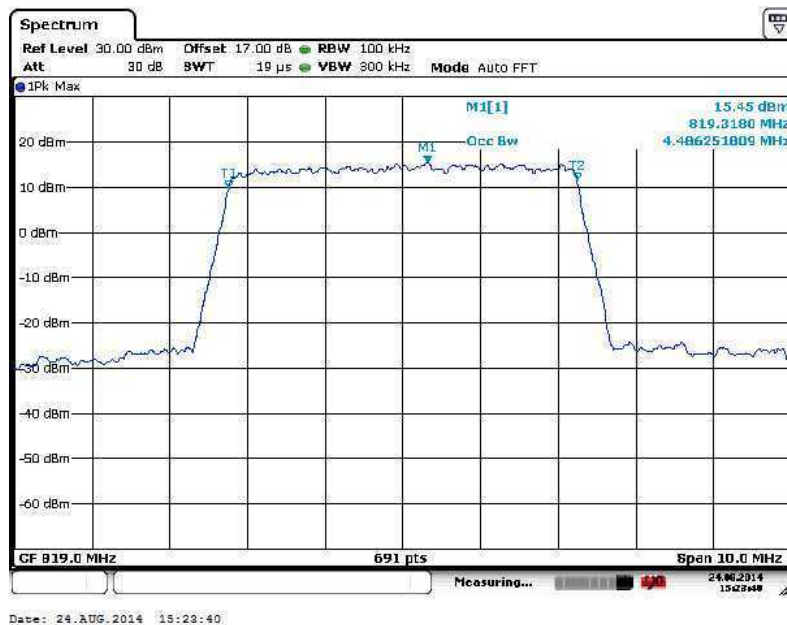

26dB Bandwidth Plot on Channel 26740

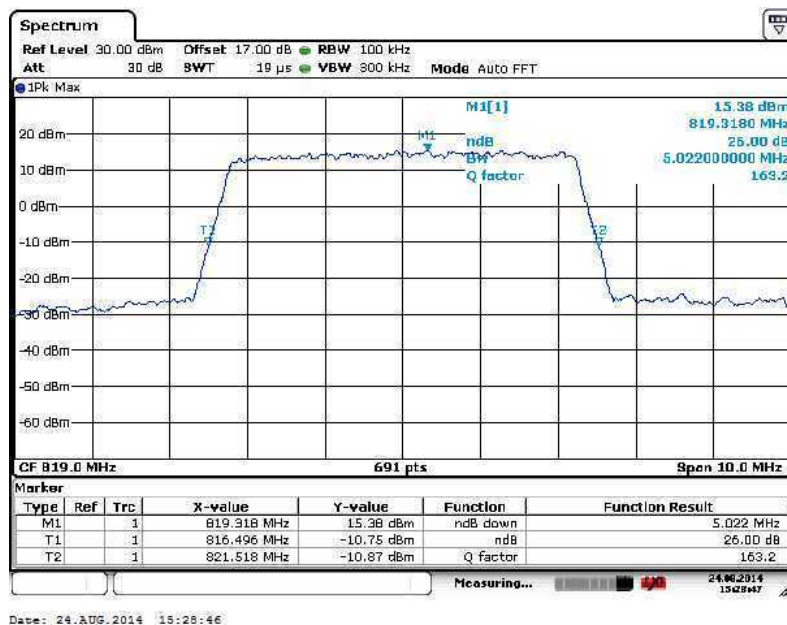



Band :	LTE Band 26	BW / Mod. :	5MHz / 16QAM
--------	-------------	-------------	--------------

**99% Occupied Bandwidth Plot on Channel 26740**

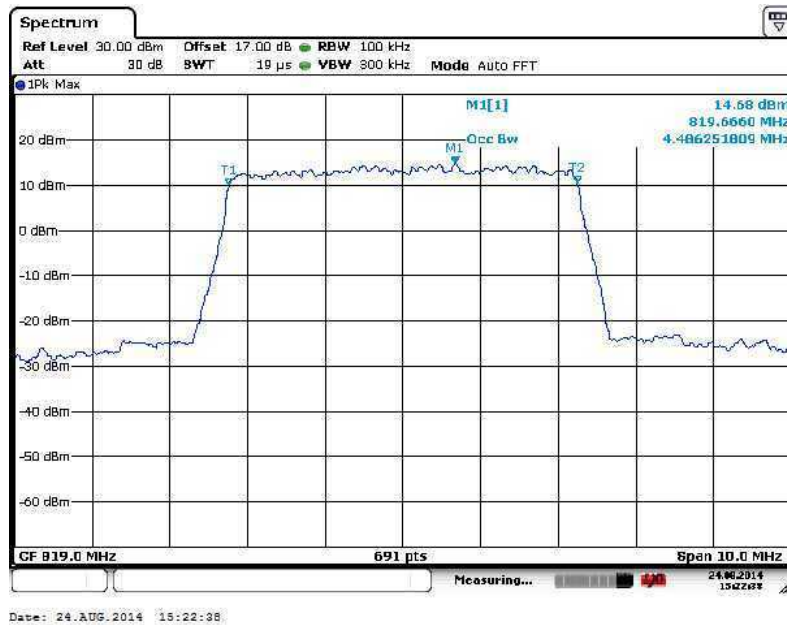

**26dB Bandwidth Plot on Channel 26740**

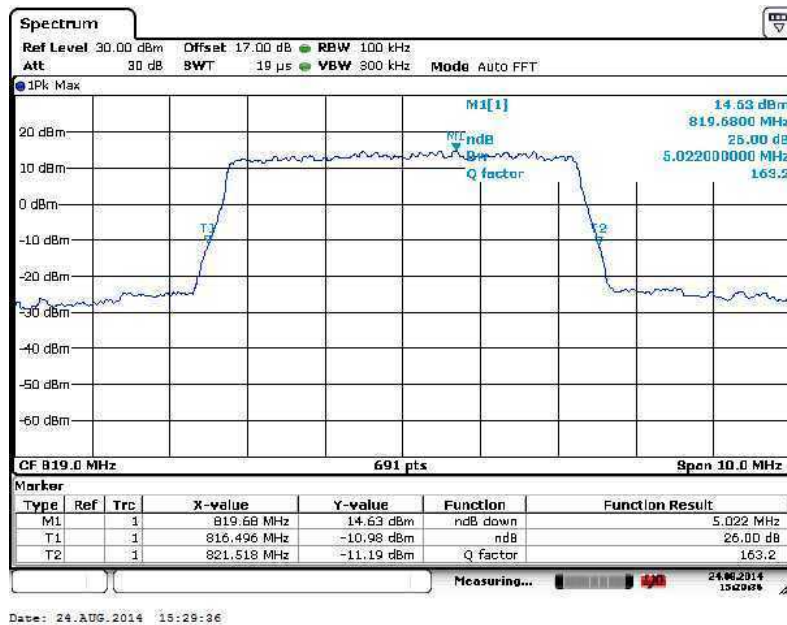



Band :	LTE Band 26	BW / Mod. :	10MHz / QPSK
--------	-------------	-------------	--------------

99% Occupied Bandwidth Plot on Channel 26740

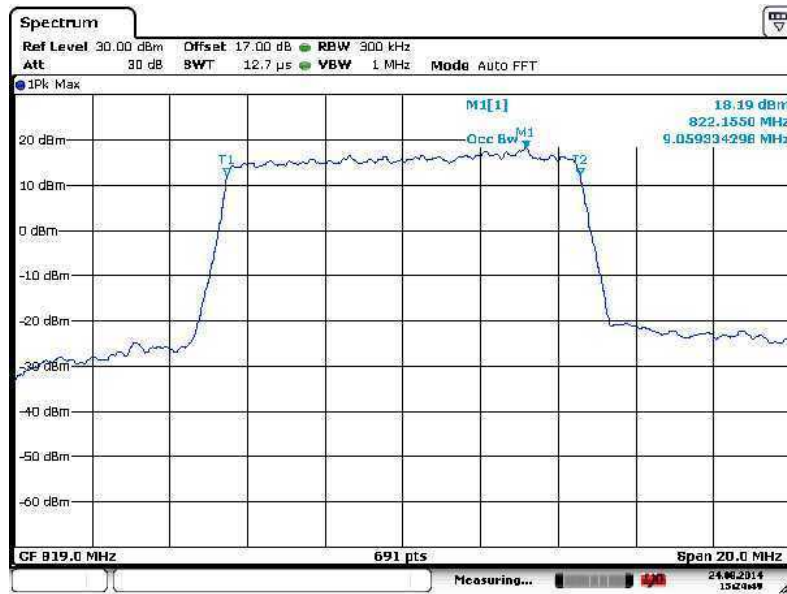

Date: 24.AUG.2014 15:24:49

26dB Bandwidth Plot on Channel 26740

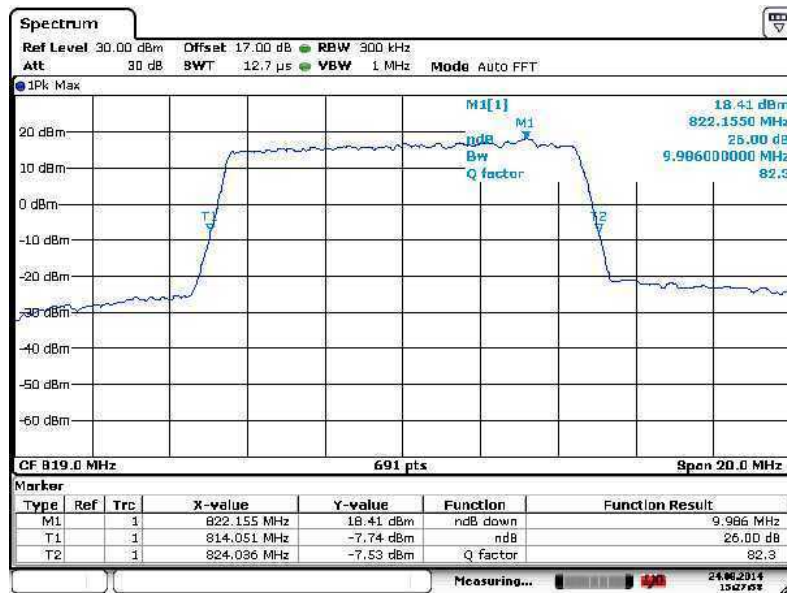

Date: 24.AUG.2014 15:27:57



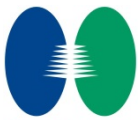

Band :	LTE Band 26	BW / Mod. :	10MHz / 16QAM
--------	-------------	-------------	---------------

99% Occupied Bandwidth Plot on Channel 26740

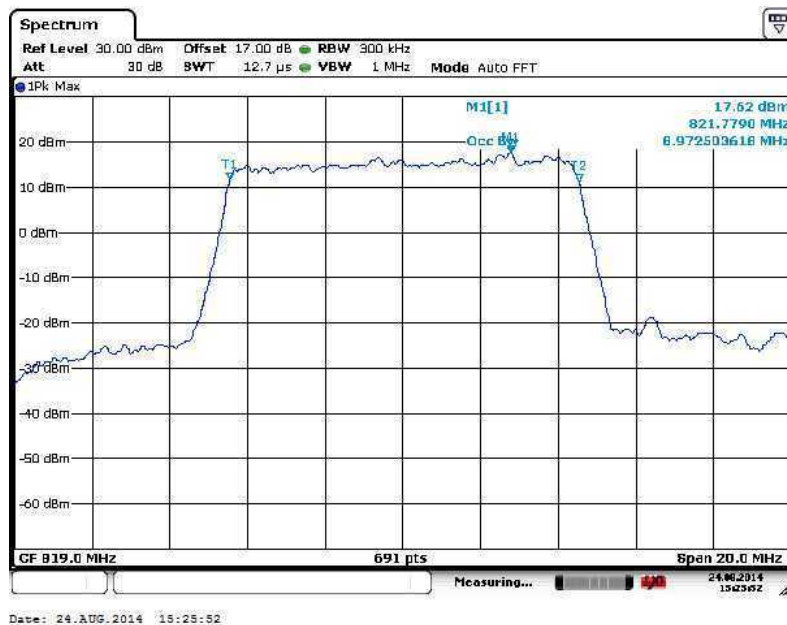

26dB Bandwidth Plot on Channel 26740

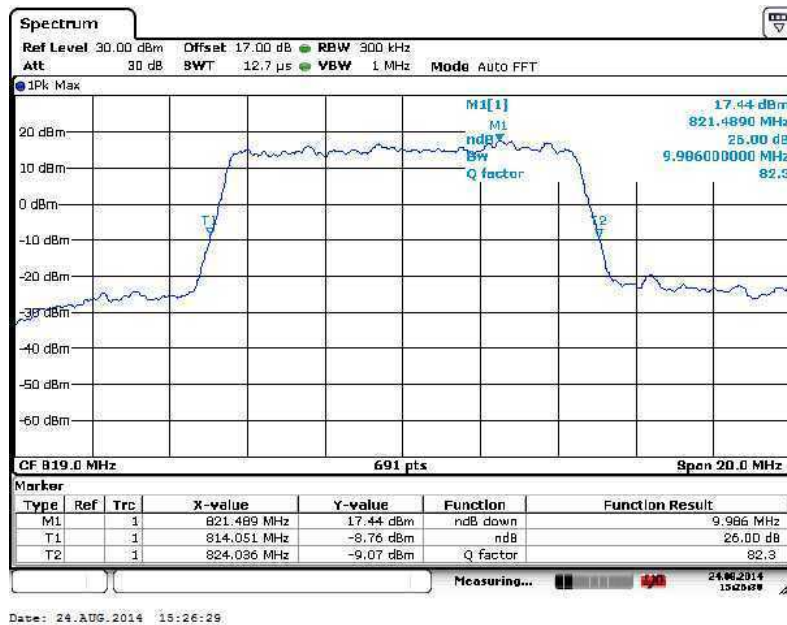

### 3.3 Emissions Mask Measurement

#### 3.3.1 Description of Emissions Mask Measurement

Equipment used in this licensed to EA or non-EA systems shall comply with the emission mask provisions of FCC Part 90.691.(a)

(a) Out-of-band emission requirement shall apply only to the “outer” channels included in an EA license and to spectrum adjacent to interior channels used by incumbent licensees. The emission limits are as follows:

(1) For any frequency removed from the EA licensee’s frequency block by up to and including 37.5 kHz, the power of any emission shall be attenuated below the transmitter power (P) in watts by at least  $116 \text{ Log}_{10}(f/6.1)$  decibels or  $50 + 10 \text{ Log}_{10}(P)$  decibels or 80 decibels, whichever is the lesser attenuation, where f is the frequency removed from the center of the outer channel in the block in kilohertz and where f is greater than 12.5 kHz.

(2) For any frequency removed from the EA licensee’s frequency block greater than 37.5 kHz, the power of any emission shall be attenuated below the transmitter power (P) in watts by at least  $43 + 10 \text{ Log}_{10}(P)$  decibels or 80 decibels, whichever is the lesser attenuation, where f is the frequency removed from the center of the outer channel in the block in kilohertz and where f is greater than 37.5 kHz.

#### 3.3.2 Measuring Instruments

The measuring equipment is listed in the section 4 of this test report.

#### 3.3.3 Test Procedures

1. The EUT was connected to spectrum analyzer and base station via power divider.
2. The emissions mask of low and high channels for the highest RF powers were measured.
3. The RBW was set 10 kHz and VBW was set 3 times of RBW.
4. Use Channel Power Option to calculate total power.
  - a. First Rang: Block Edge ~ 37.5kHz, Channel Power BW = 37.5kHz
  - b. Sec. Rang: greater than 37.5kHz, Channel Power BW = 100kHz

#### 3.3.4 Test Setup

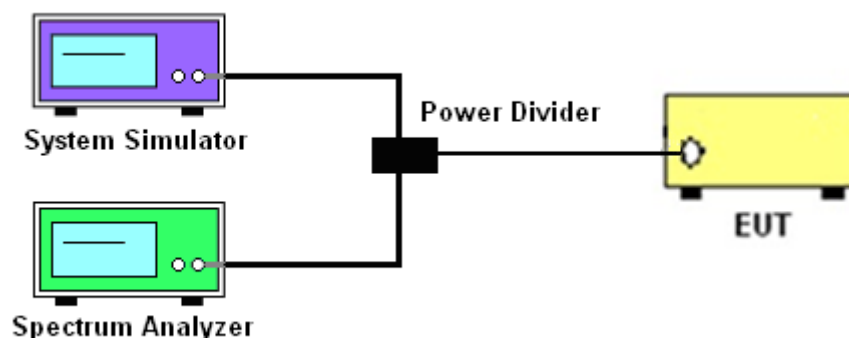



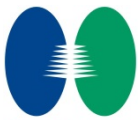

### 3.3.5 Test Result (Plots) of Conducted Emissions Mask

Band :	LTE Band 26	Band Width :	1.4MHz / QPSK
--------	-------------	--------------	---------------

Lower Band Edge Plot for QPSK-RB Size 1, RB Offset 0

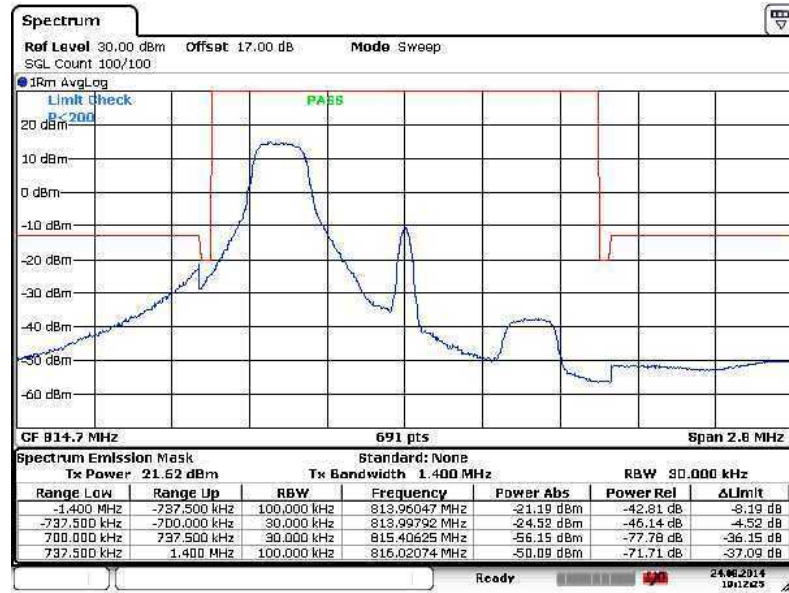

Lower Band Edge Plot for QPSK-RB Size 6, RB Offset 0

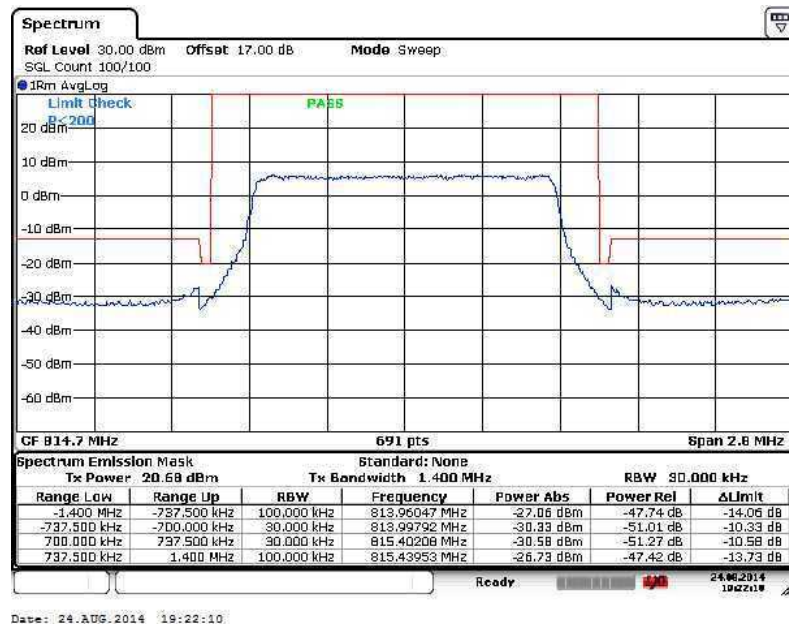



### Higher Band Edge Plot for QPSK-RB Size 1, RB Offset 5

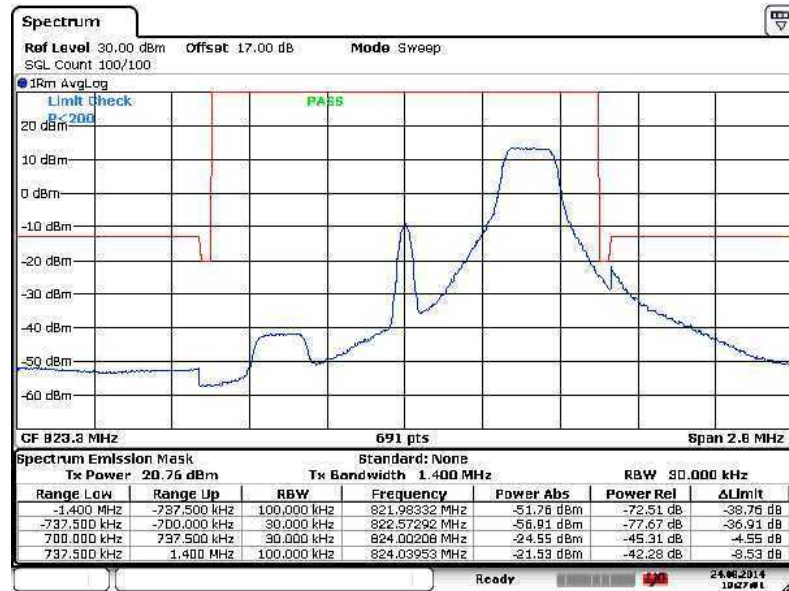

Date: 24.AUG.2014 19:27:01

### Higher Band Edge Plot for QPSK-RB Size 6, RB Offset 0

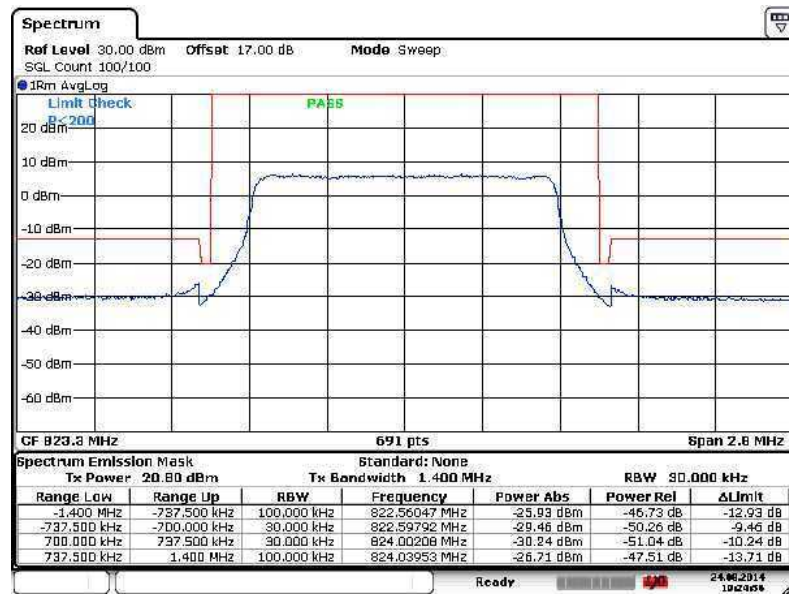

Date: 24.AUG.2014 19:24:56



Band :	LTE Band 26	Band Width :	1.4MHz / 16QAM
--------	-------------	--------------	----------------

Lower Band Edge Plot for 16QAM -RB Size 1, RB Offset 0

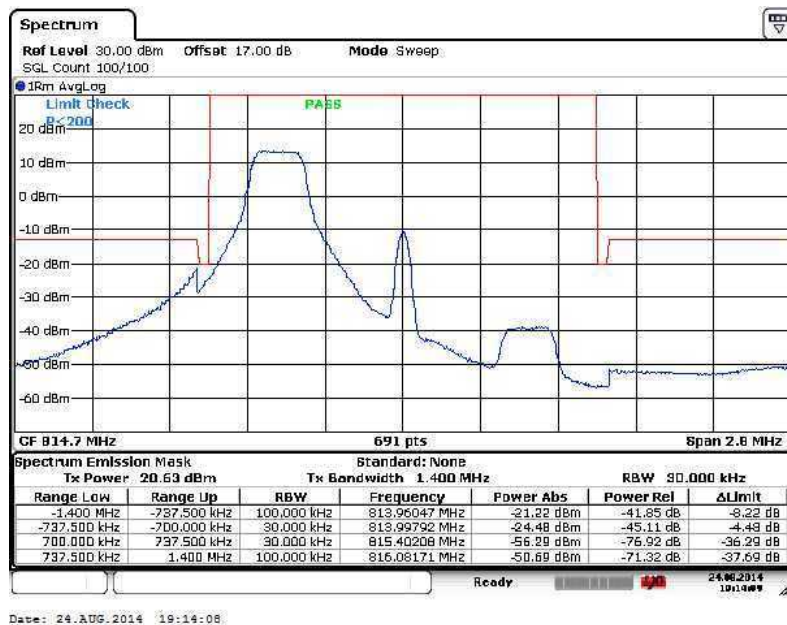

Lower Band Edge Plot for 16QAM-RB Size 6, RB Offset 0

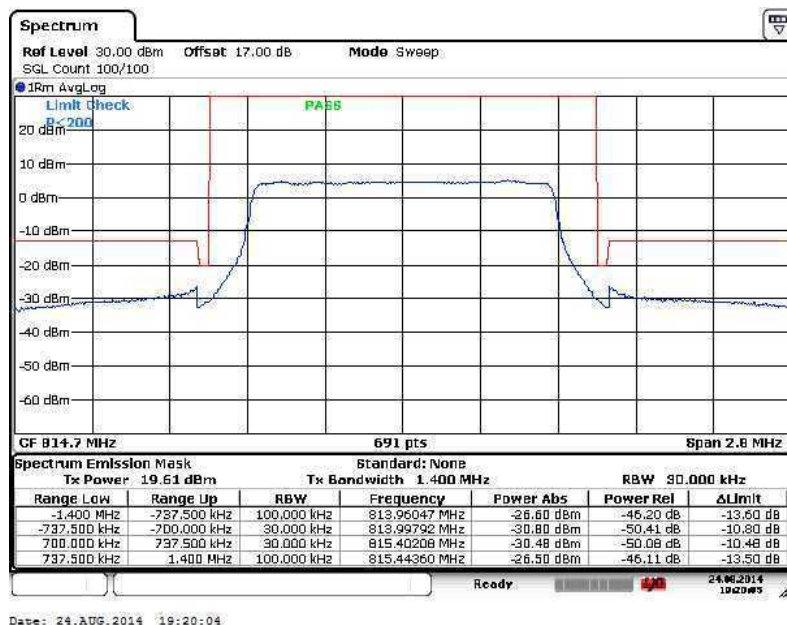

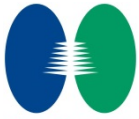

### Higher Band Edge Plot for 16QAM-RB Size 1, RB Offset 5

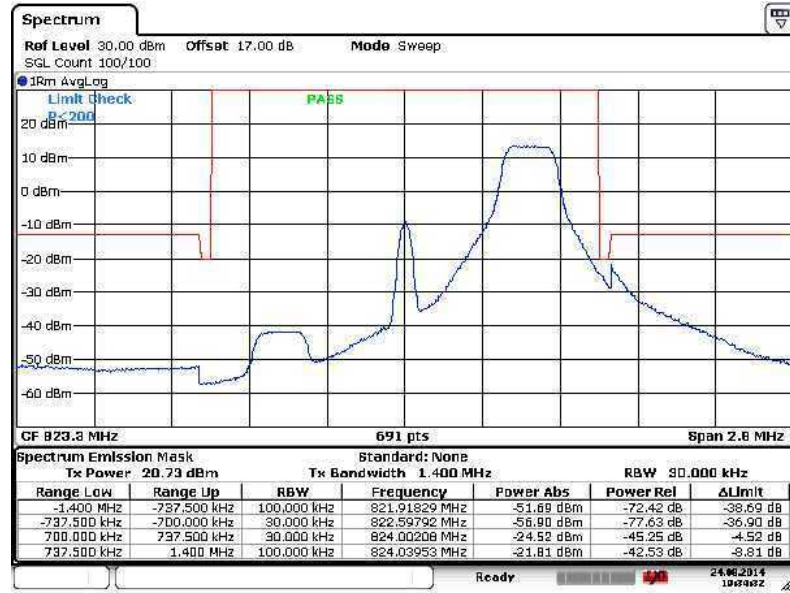

Date: 24.AUG.2014 19:34:32

### Higher Band Edge Plot for 16QAM-RB Size 6, RB Offset 0

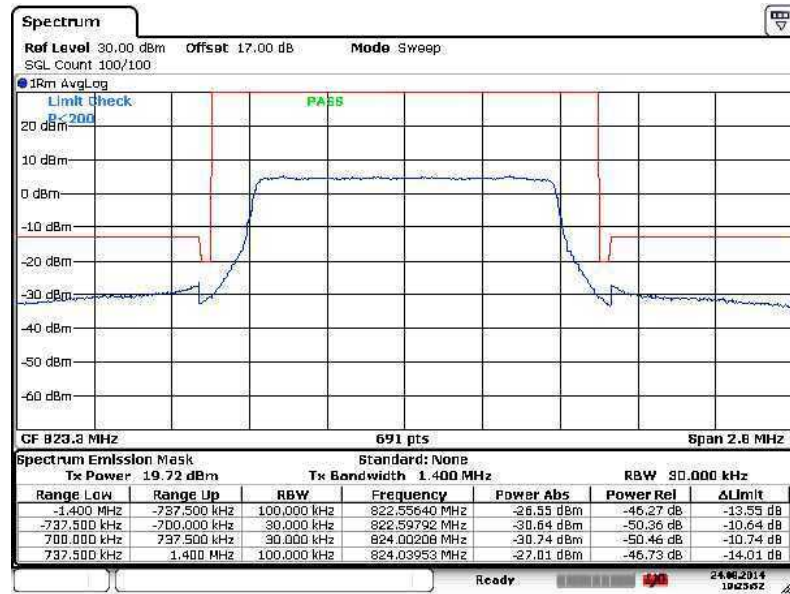

Date: 24.AUG.2014 19:25:51



Band :	LTE Band 26	Band Width :	3MHz / QPSK
--------	-------------	--------------	-------------

Lower Band Edge Plot for QPSK-RB Size 1, RB Offset 0

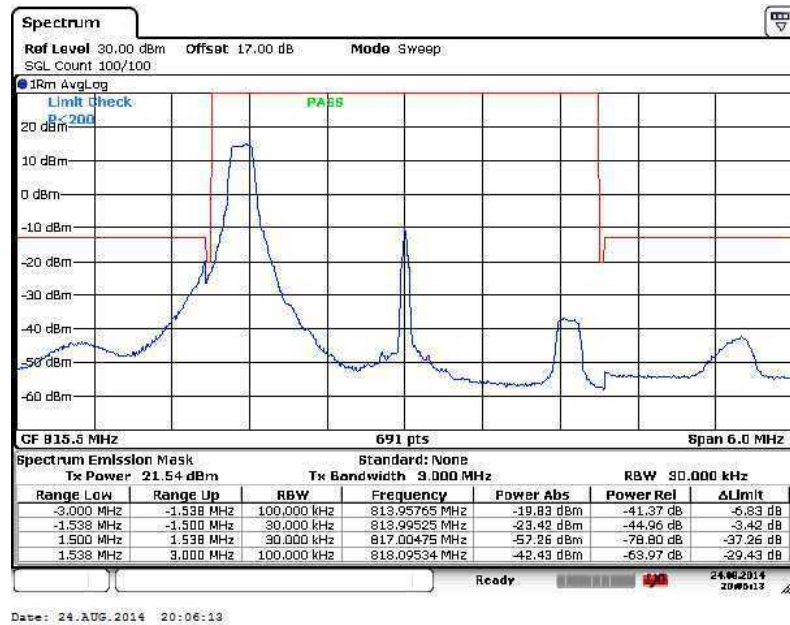

Lower Band Edge Plot for QPSK-RB Size 15, RB Offset 0

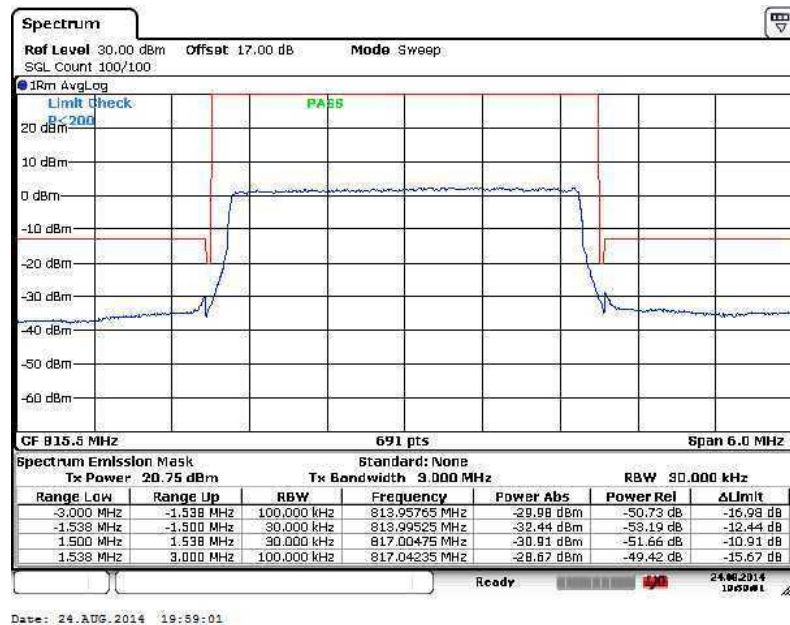



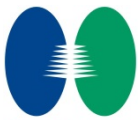

### Higher Band Edge Plot for QPSK-RB Size 1, RB Offset 14

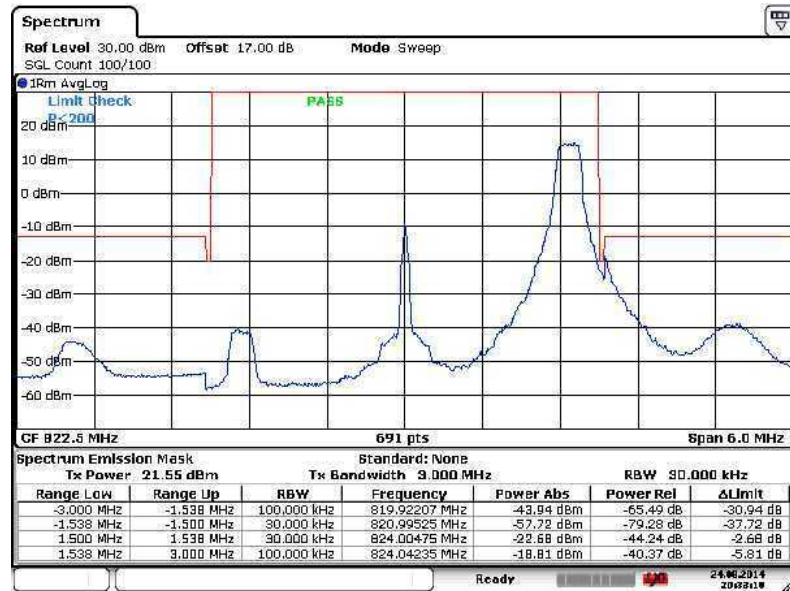

### Higher Band Edge Plot for QPSK-RB Size 15, RB Offset 0

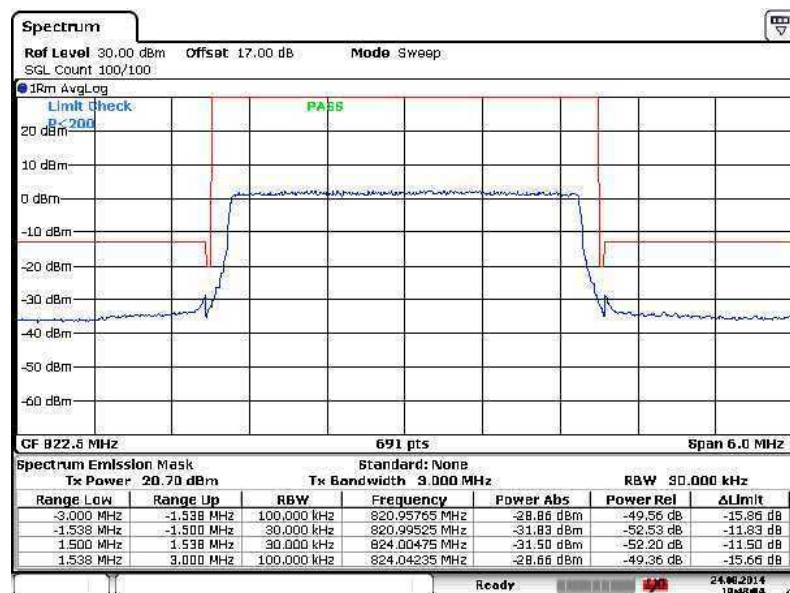



Band :	LTE Band 26	Band Width :	3MHz / 16QAM
--------	-------------	--------------	--------------

Lower Band Edge Plot for 16QAM-RB Size 1, RB Offset 0

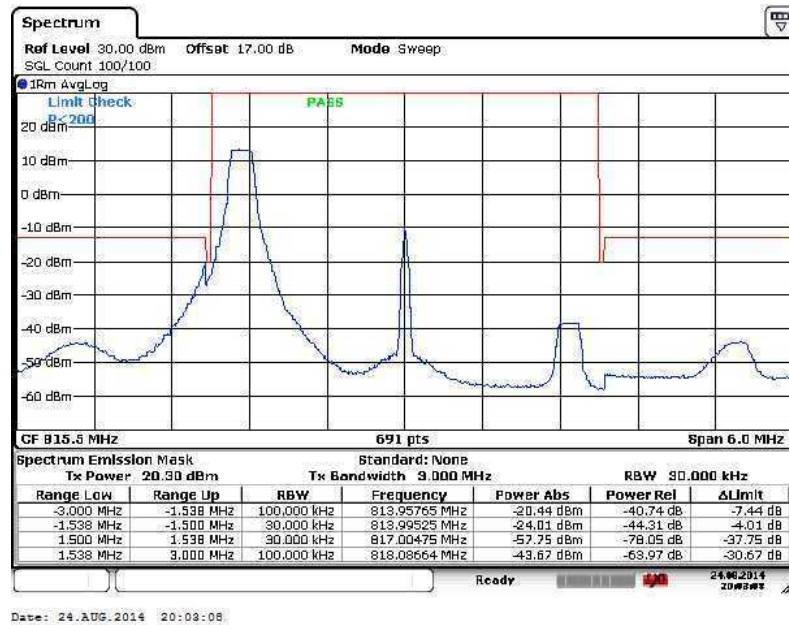

Lower Band Edge Plot for 16QAM-RB Size 15, RB Offset 0

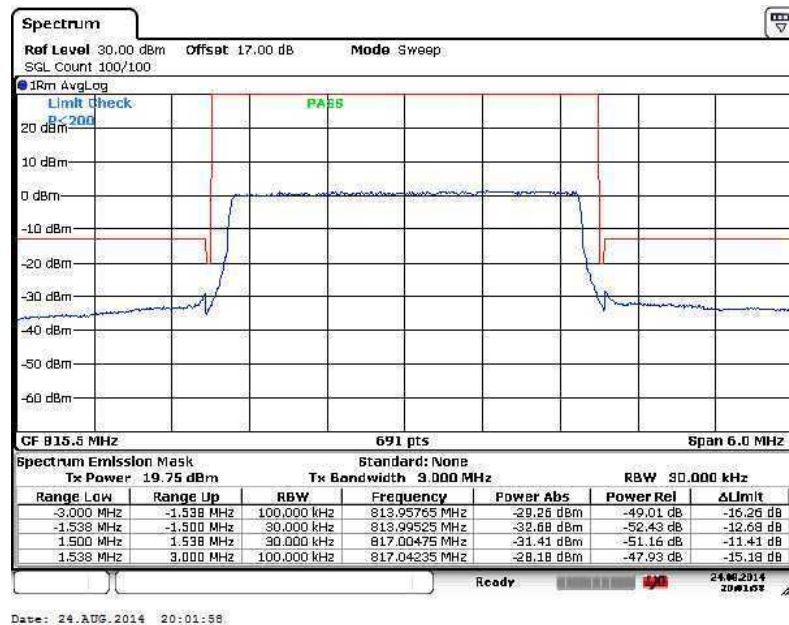



### Higher Band Edge Plot for 16QAM-RB Size 1, RB Offset 14

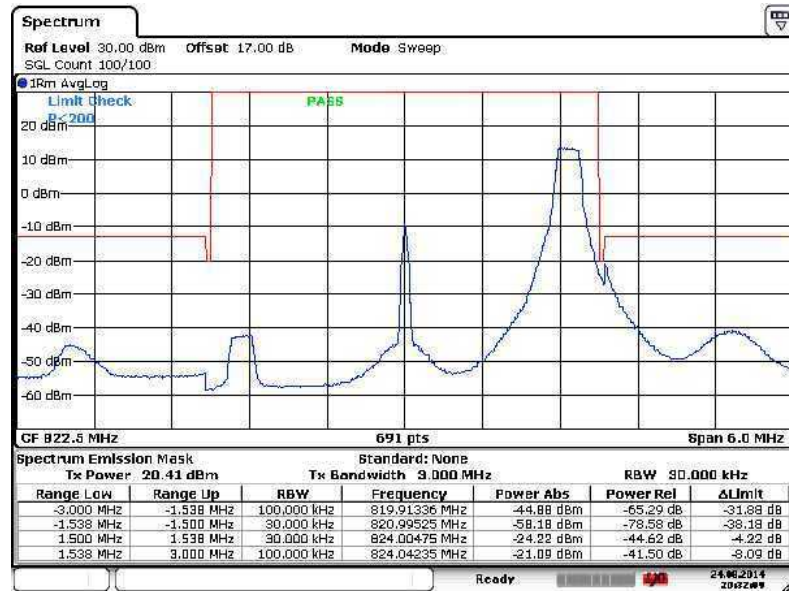

### Higher Band Edge Plot for 16QAM-RB Size 15, RB Offset 0

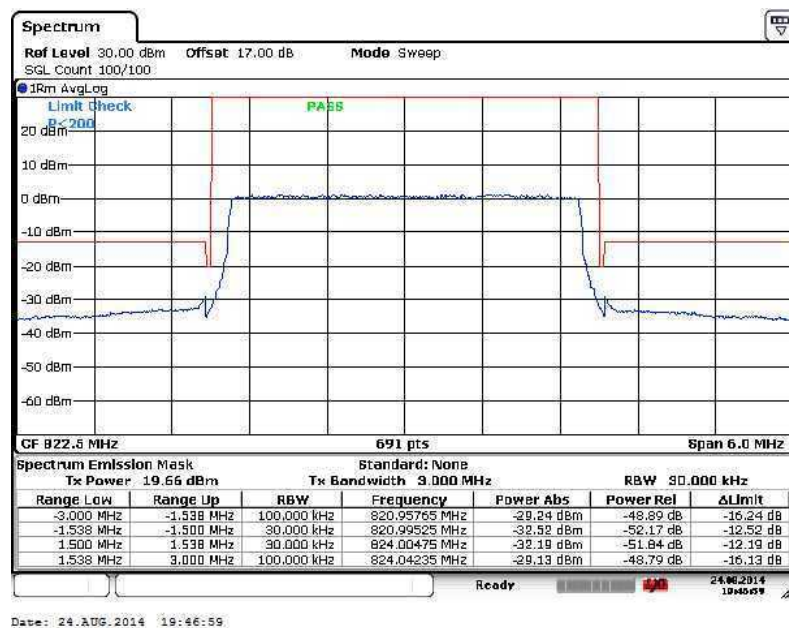



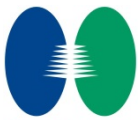

Band :	LTE Band 26	Band Width :	5MHz / QPSK
--------	-------------	--------------	-------------

Lower Band Edge Plot for QPSK-RB Size 1, RB Offset 0

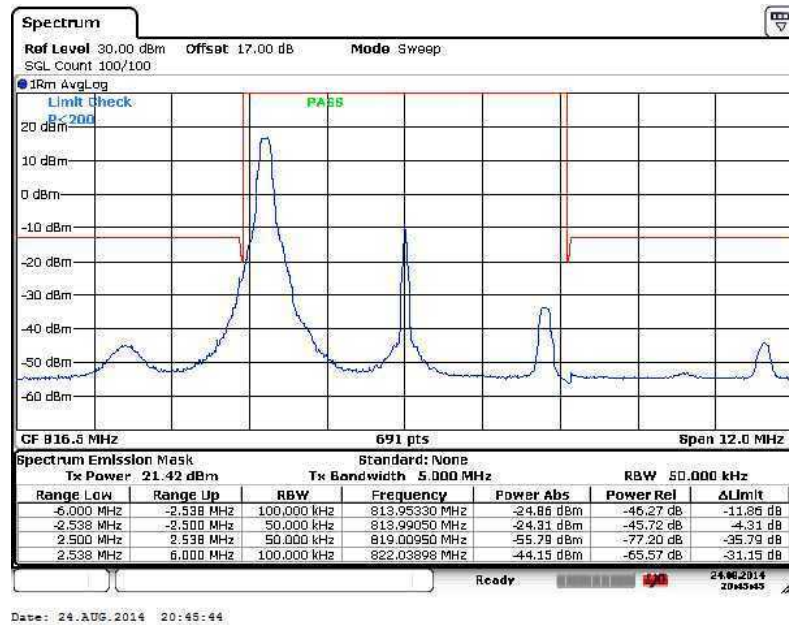

Lower Band Edge Plot for QPSK-RB Size 25, RB Offset 0

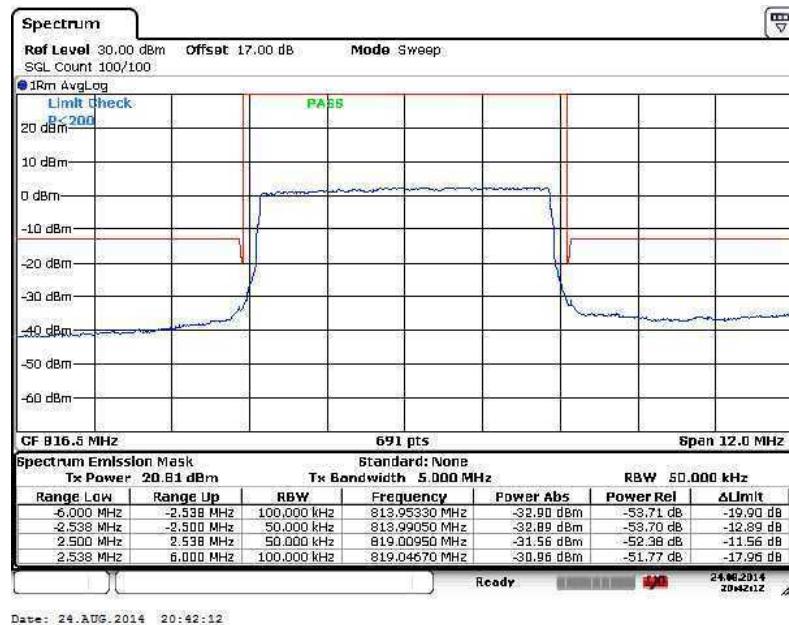



### Higher Band Edge Plot for QPSK-RB Size 1, RB Offset 24

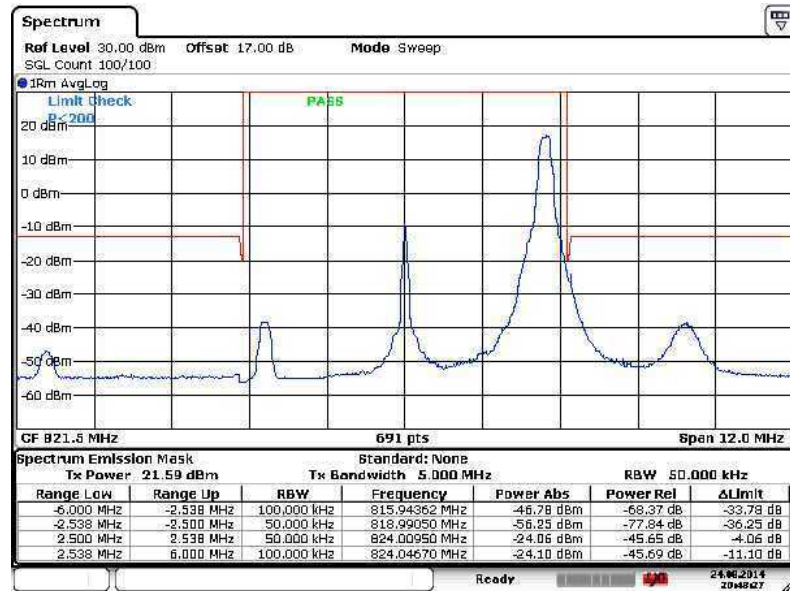

Date: 24.AUG.2014 20:48:27

### Higher Band Edge Plot for QPSK-RB Size 25, RB Offset 0

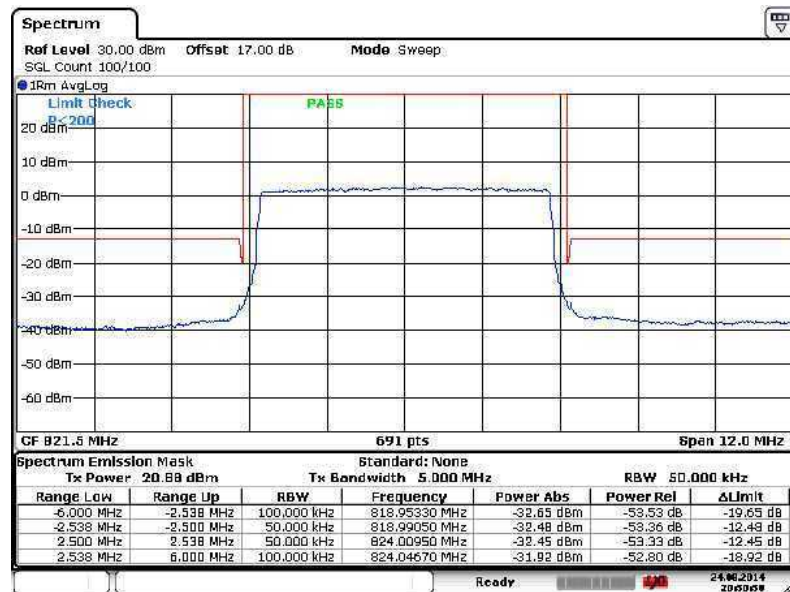

Date: 24.AUG.2014 20:50:49



Band :	LTE Band 26	Band Width :	5MHz / 16QAM
--------	-------------	--------------	--------------

Lower Band Edge Plot for 16QAM-RB Size 1, RB Offset 0

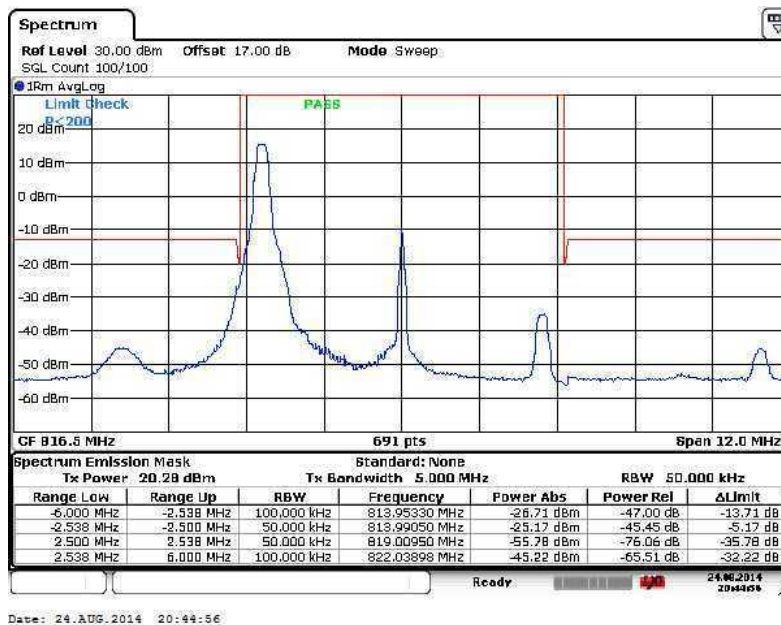

Lower Band Edge Plot for 16QAM-RB Size 25, RB Offset 0

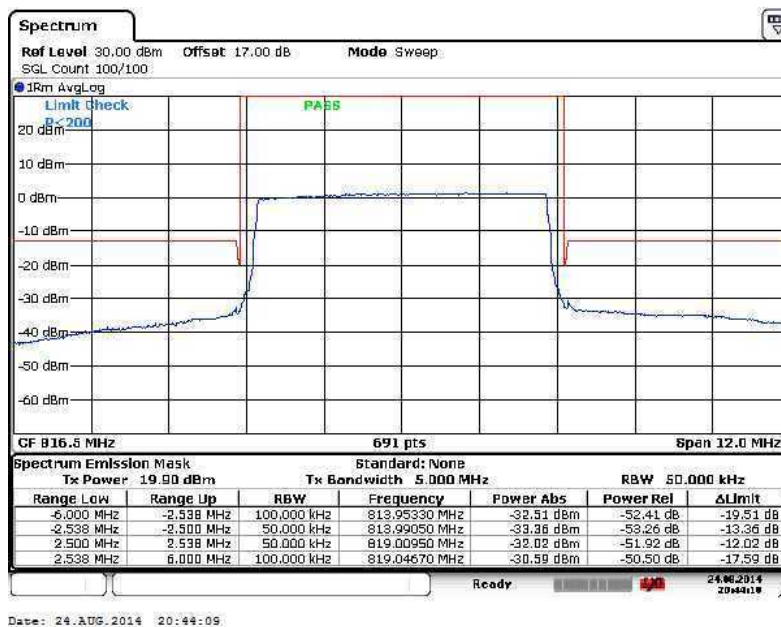

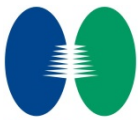

### Higher Band Edge Plot for 16QAM-RB Size 1, RB Offset 24

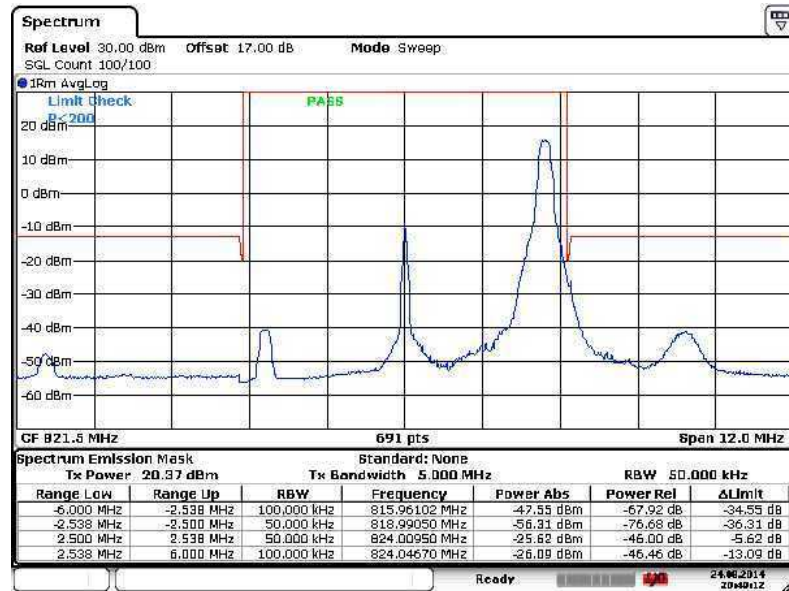

### Higher Band Edge Plot for 16QAM-RB Size 25, RB Offset 0

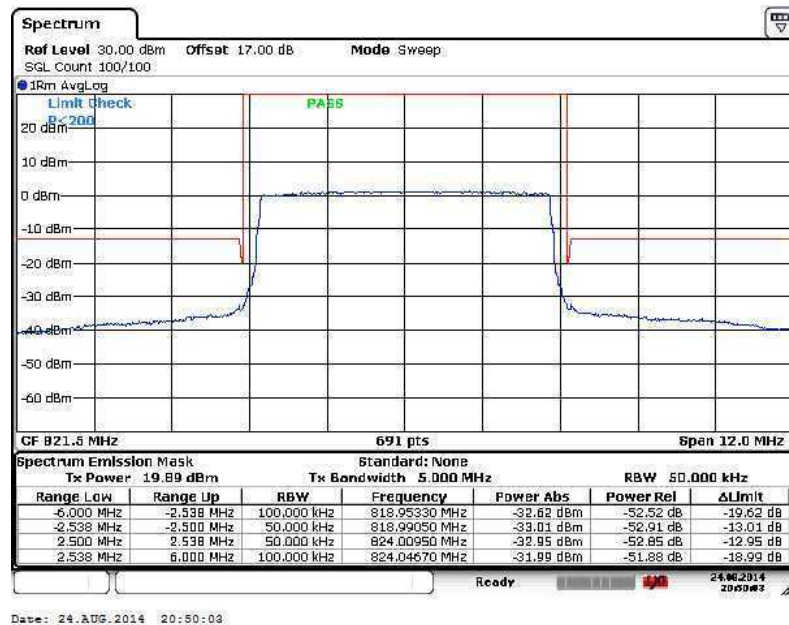



<b>Band :</b>	LTE Band 26	<b>Band Width :</b>	10MHz / QPSK
---------------	-------------	---------------------	--------------

**Band Edge Plot for QPSK-RB Size 1, RB Offset 0**

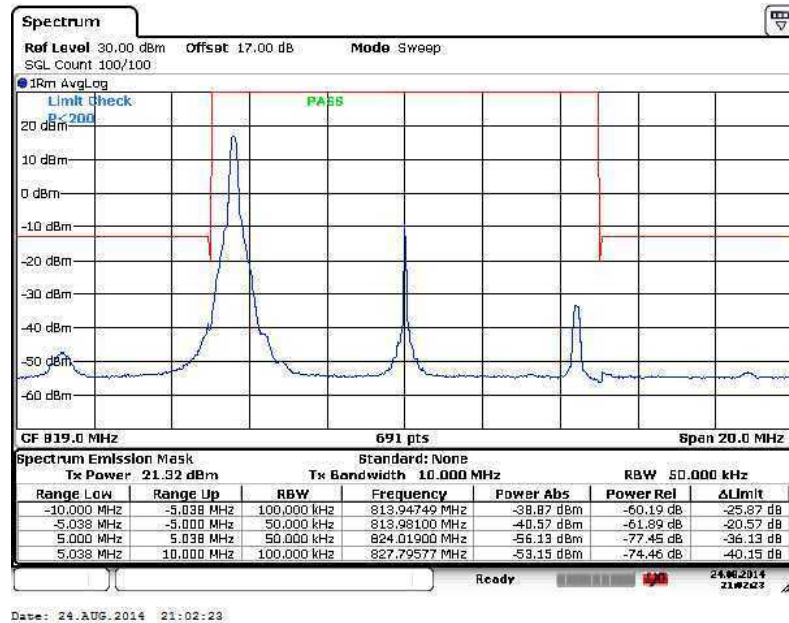

**Band Edge Plot for QPSK-RB Size 1, RB Offset 49**

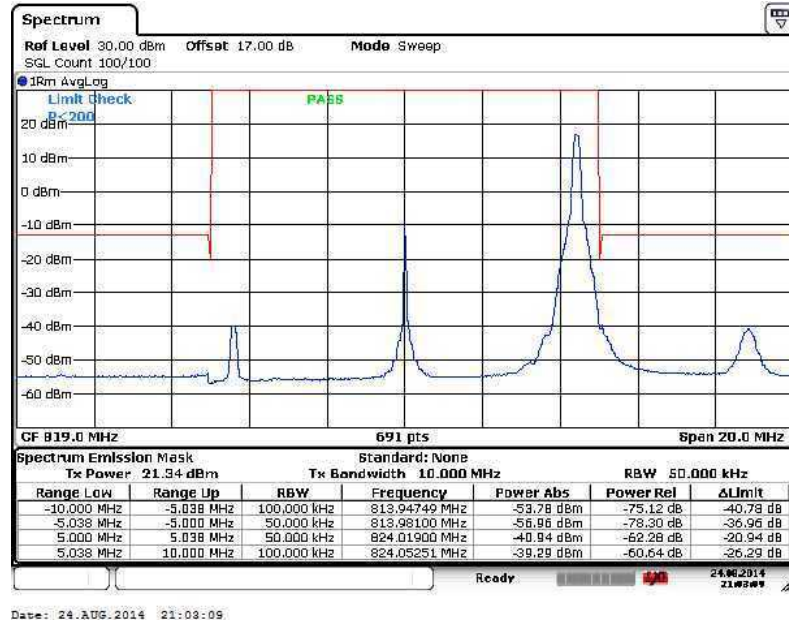



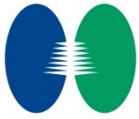

Band Edge Plot for QPSK-RB Size 50 RB Offset 0

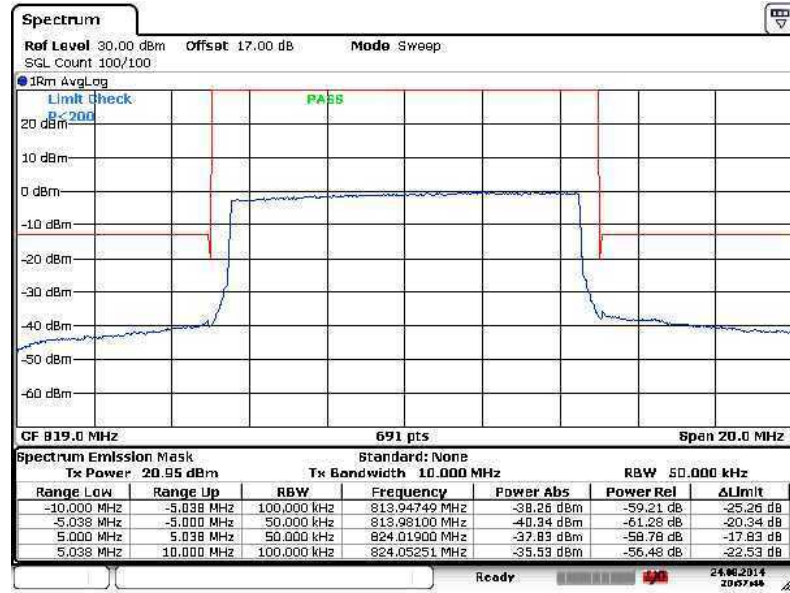

Date: 24.AUG.2014 20:57:46



<b>Band :</b>	LTE Band 26	<b>Band Width :</b>	10MHz / 16QAM
---------------	-------------	---------------------	---------------

**Band Edge Plot for 16QAM-RB Size 1, RB Offset 0**

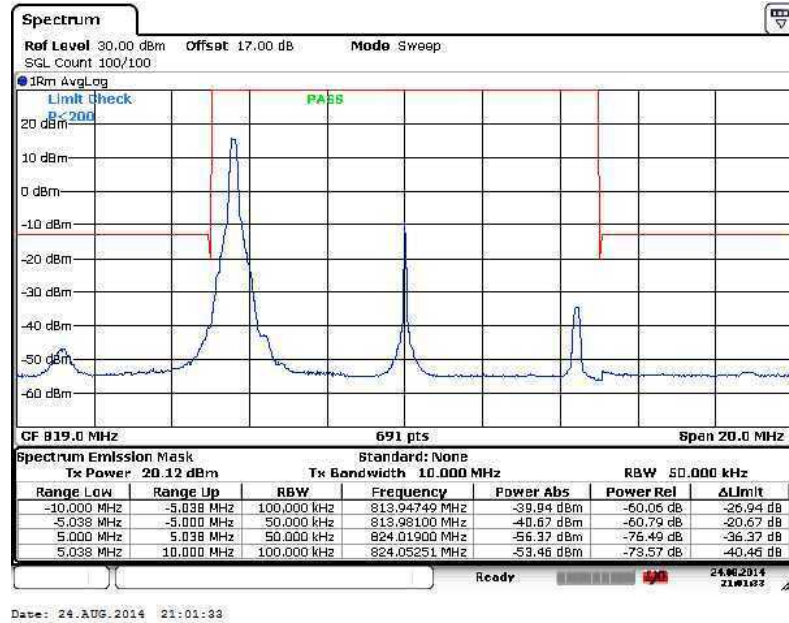

**Band Edge Plot for 16QAM-RB Size 1, RB Offset 49**

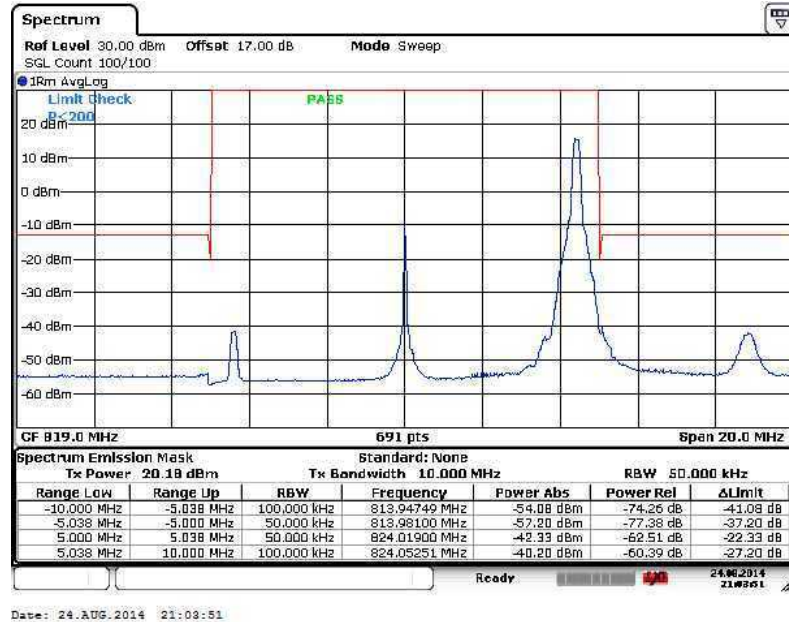



Band Edge Plot for 16QAM-RB Size 50 RB Offset 0

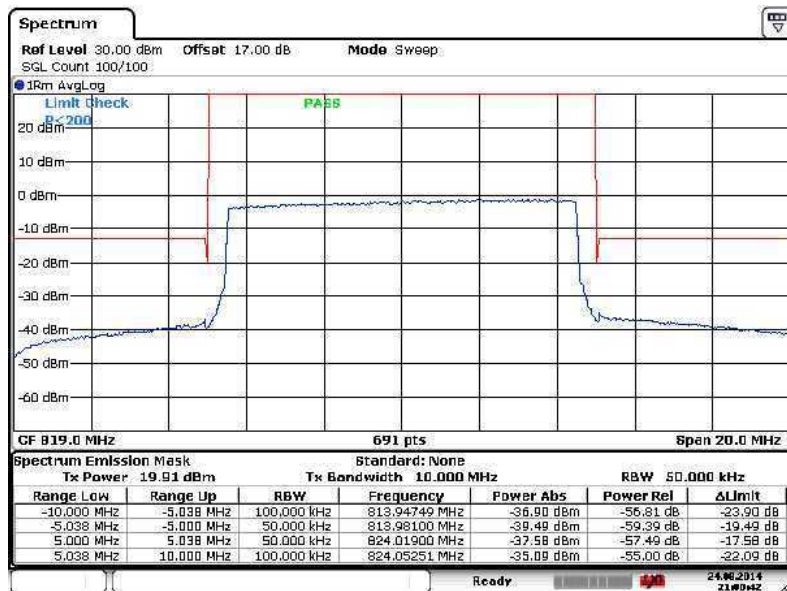

Date: 24.AUG.2014 21:00:42



### 3.4 Emissions Mask – Out Of Band Emissions Measurement

#### 3.4.1 Description of Conducted Emissions Out of band emissions measurement

The power of any emission FCC Part 90.691 (a)(2) on any frequency removed from the assigned frequency by out of the authorized bandwidth at least  $43 + 10 \log (P)$  dB. It is measured by means of a calibrated spectrum analyzer and scanned from 30 MHz up to a frequency including its 10<sup>th</sup> harmonic.

#### 3.4.2 Measuring Instruments

The measuring equipment is listed in the section 4 of this test report.

#### 3.4.3 Test Procedures

1. The EUT was connected to spectrum analyzer and base station via power divider.
2. The middle channel for the highest RF power within the transmitting frequency was measured.
3. The conducted spurious emission for the whole frequency range was taken.
4. The final test results were shown below plots with a correction offset factor including cable loss, insertion loss of power divider.

#### 3.4.4 Test Setup

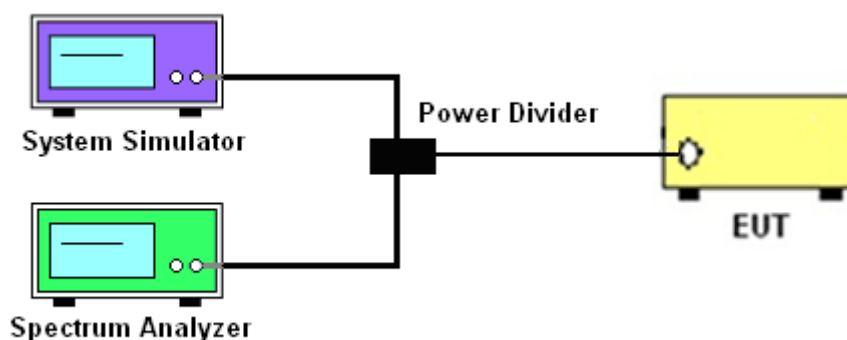



### 3.4.5 Test Result (Plots) of Conducted Emission

Band :	LTE Band 26	Channel :	CH26697 (Low)
Band Width :	1.4MHz		

#### QPSK (RB Size 1, RB Offset 5)

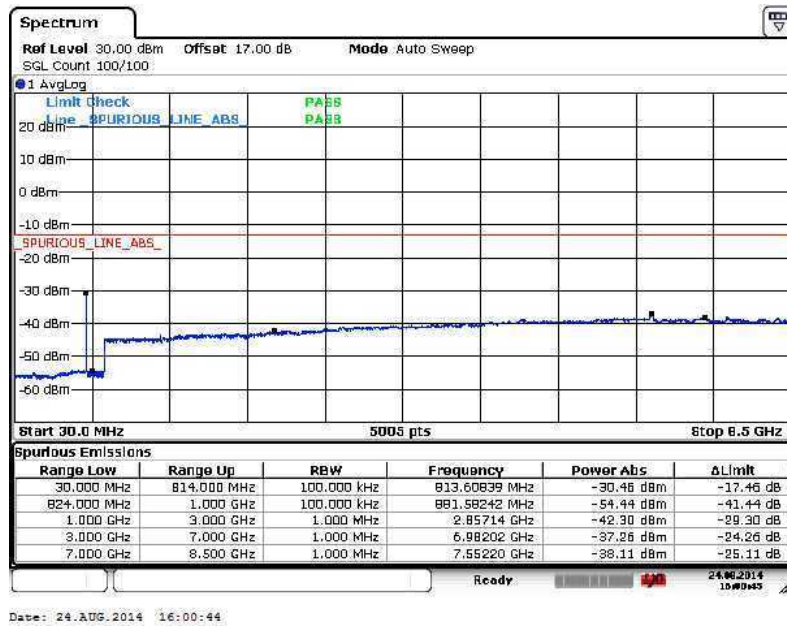

#### 16QAM (RB Size 1, RB Offset 2)

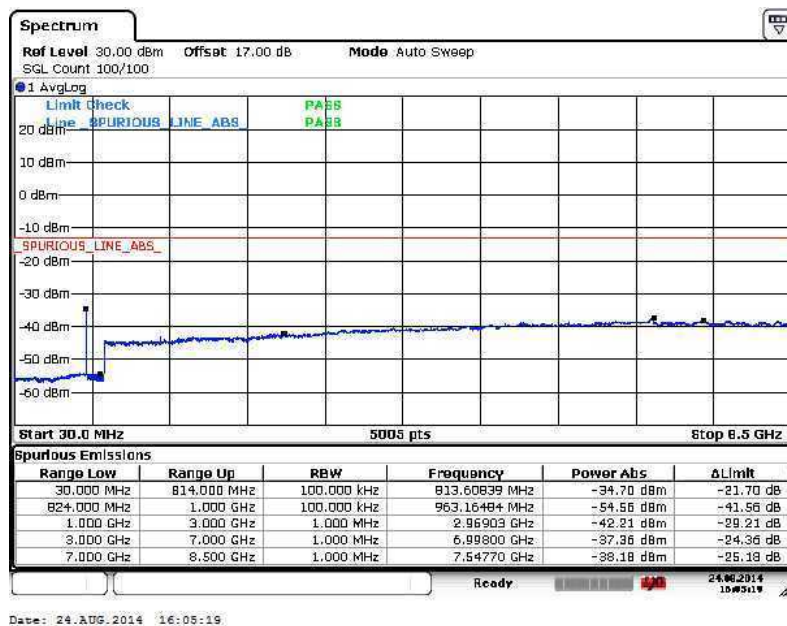



Band :	LTE Band 26	Channel :	CH26740 (Middle)
Band Width :	1.4MHz		

QPSK (RB Size 1, RB Offset 5)

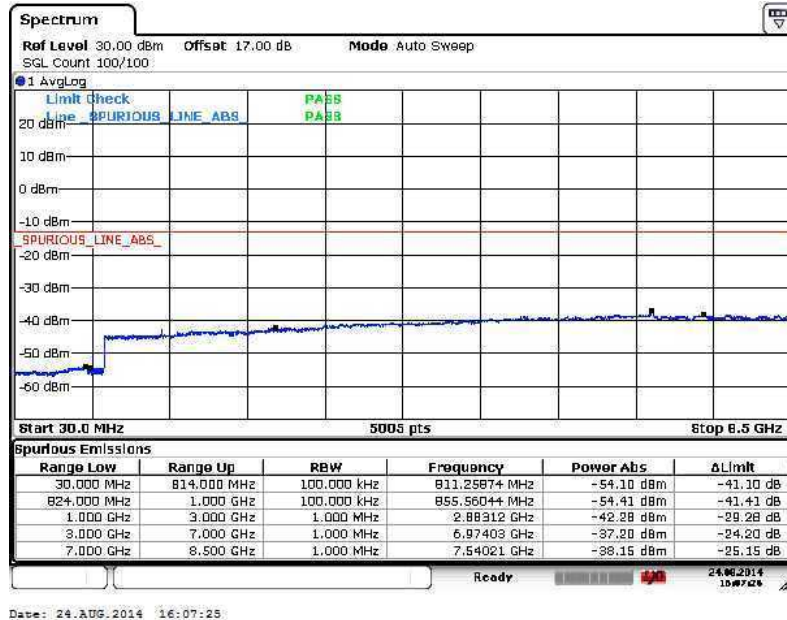

16QAM (RB Size 1, RB Offset 5)

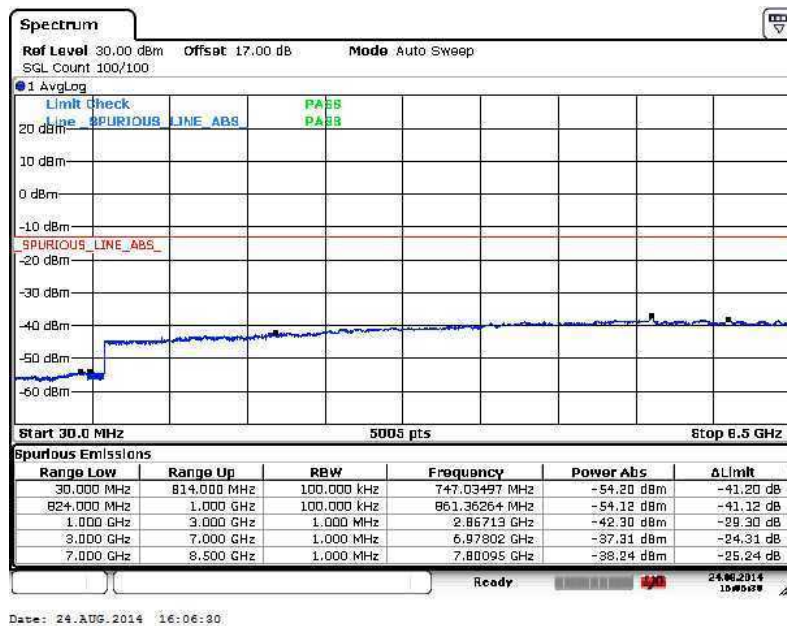

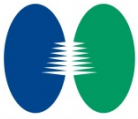

Band :	LTE Band 26	Channel :	CH26783 (High)
Band Width :	1.4MHz		

**QPSK (RB Size 1, RB Offset 0)**

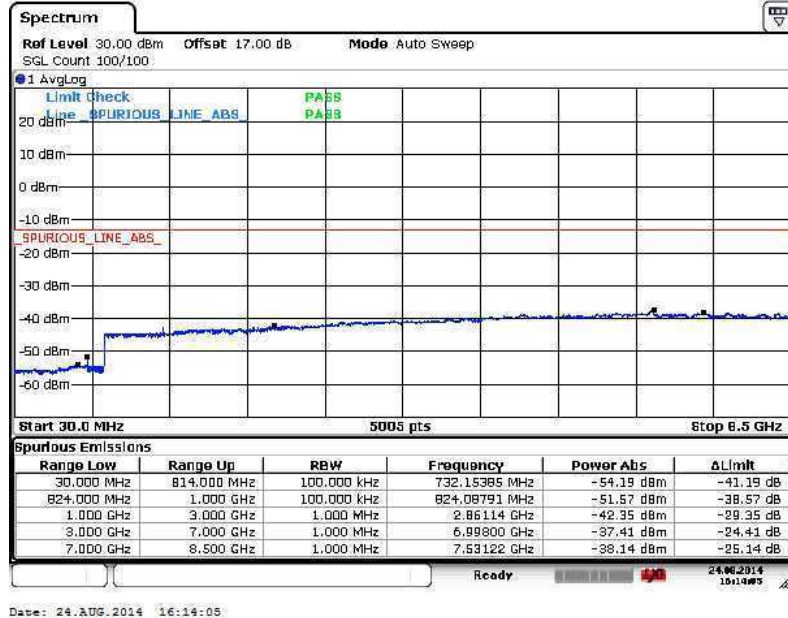

**16QAM (RB Size 1, RB Offset 2)**

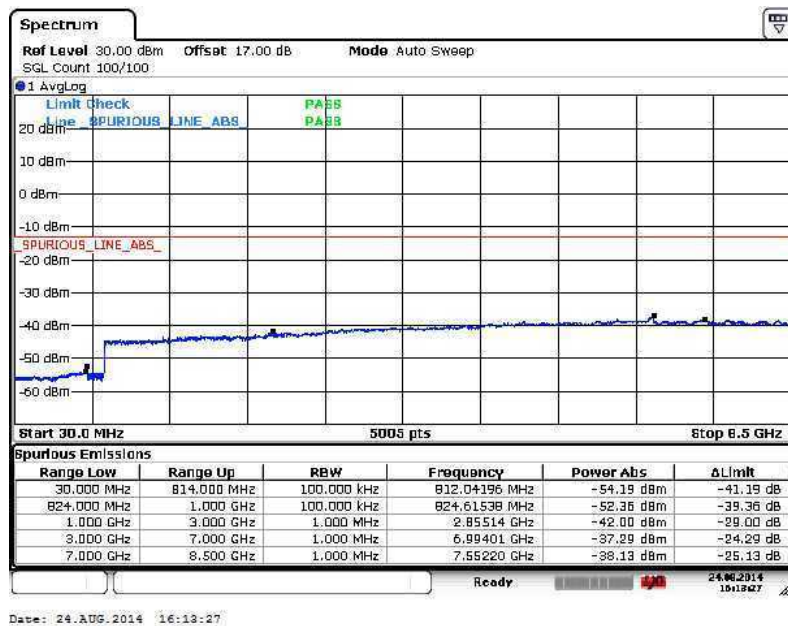



Band :	LTE Band 26	Channel :	CH26705 (Low)
Band Width :	3MHz		

QPSK (RB Size 1, RB Offset 0)

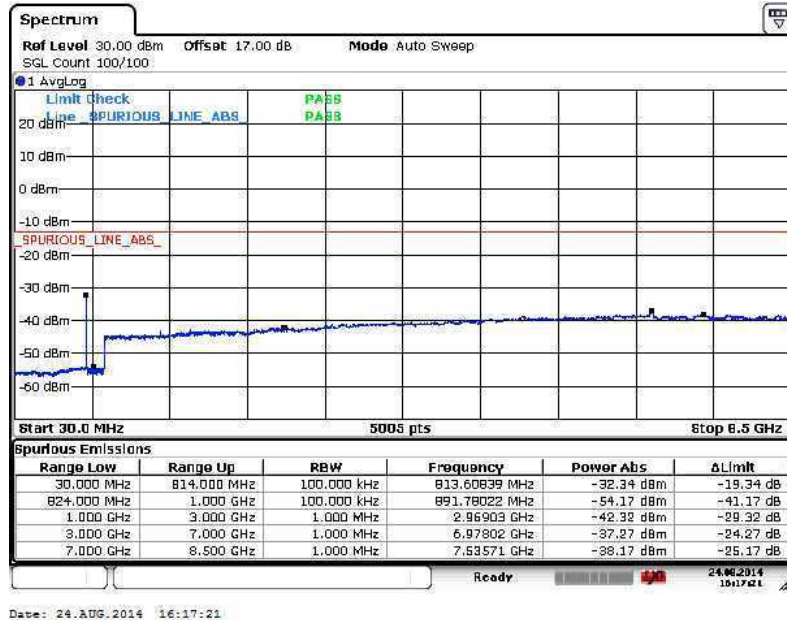

16QAM (RB Size 1, RB Offset 0)

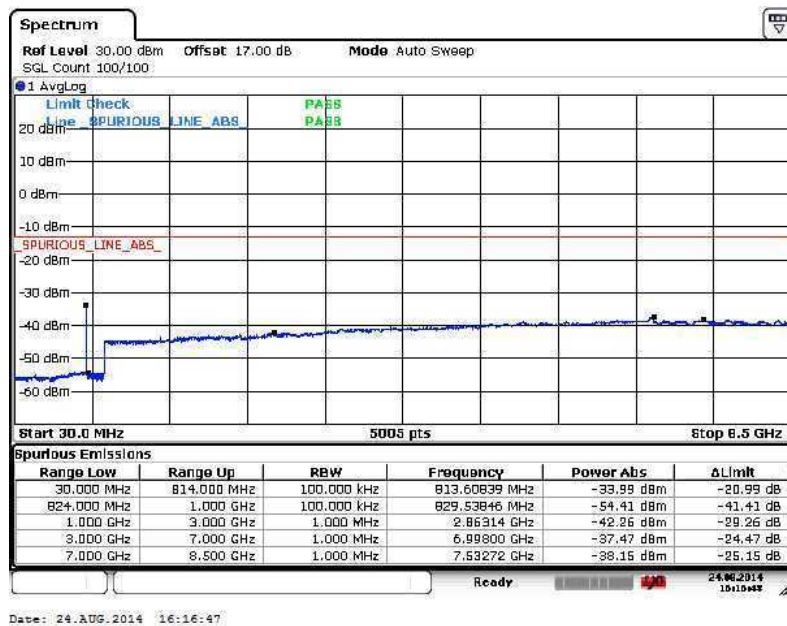



Band :	LTE Band 26	Channel :	CH26740 (Middle)
Band Width :	3MHz		

QPSK (RB Size 1, RB Offset 14)

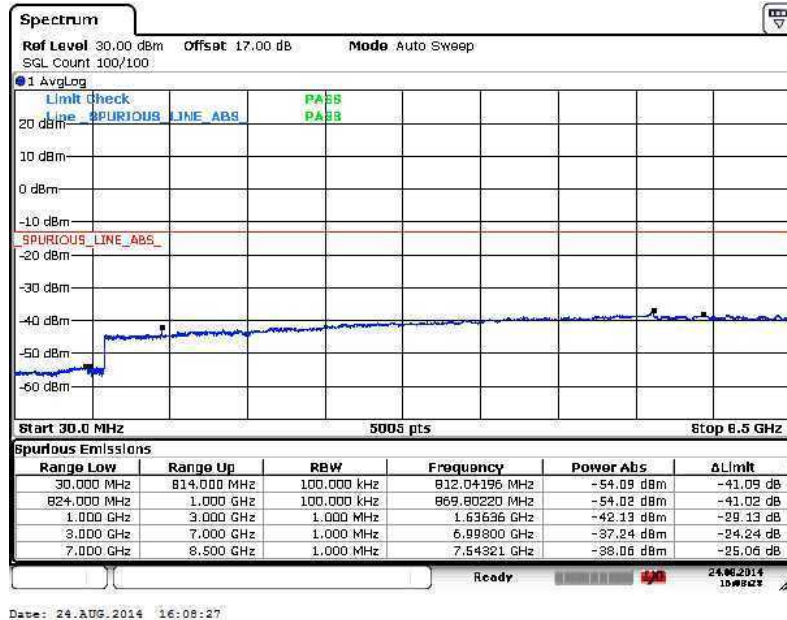

16QAM (RB Size 1, RB Offset 0)

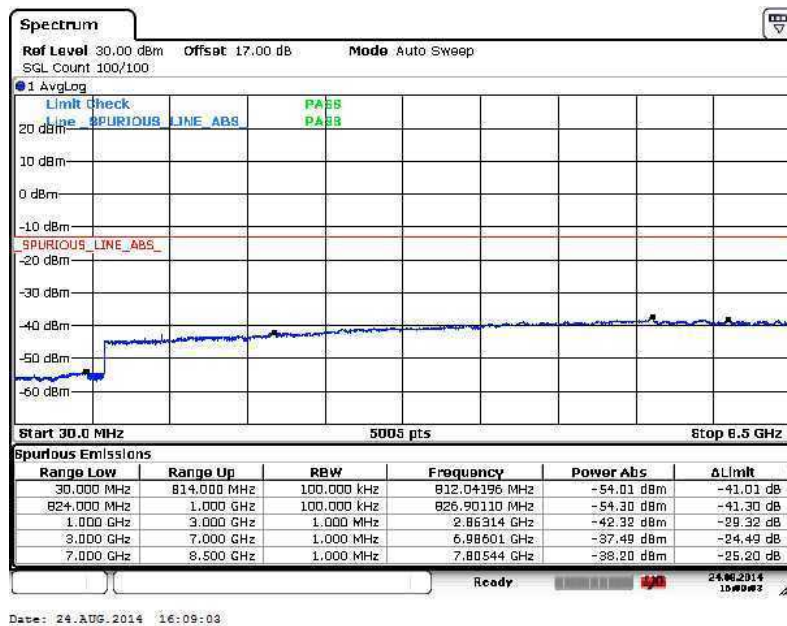





Band :	LTE Band 26	Channel :	CH26775 (High)
Band Width :	3MHz		

**QPSK (RB Size 1, RB Offset 14)**

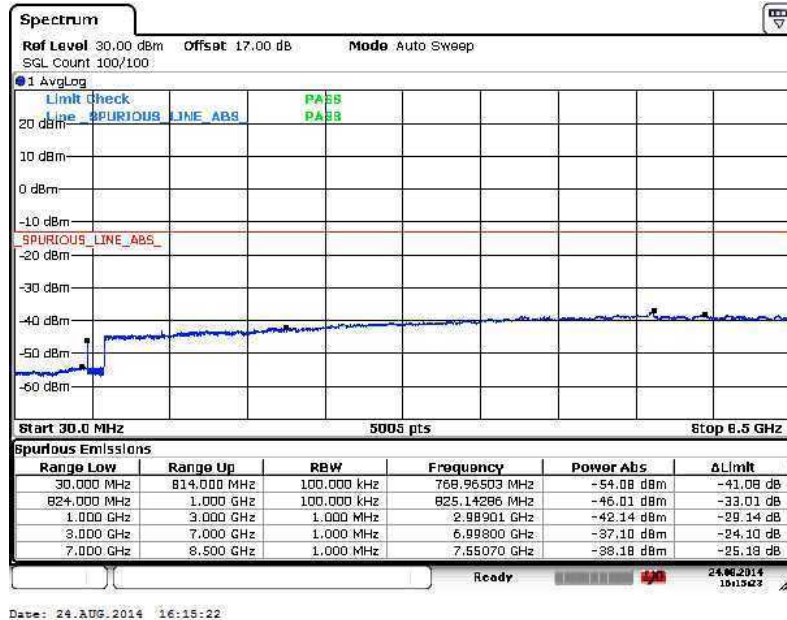

**16QAM (RB Size 1, RB Offset 0)**

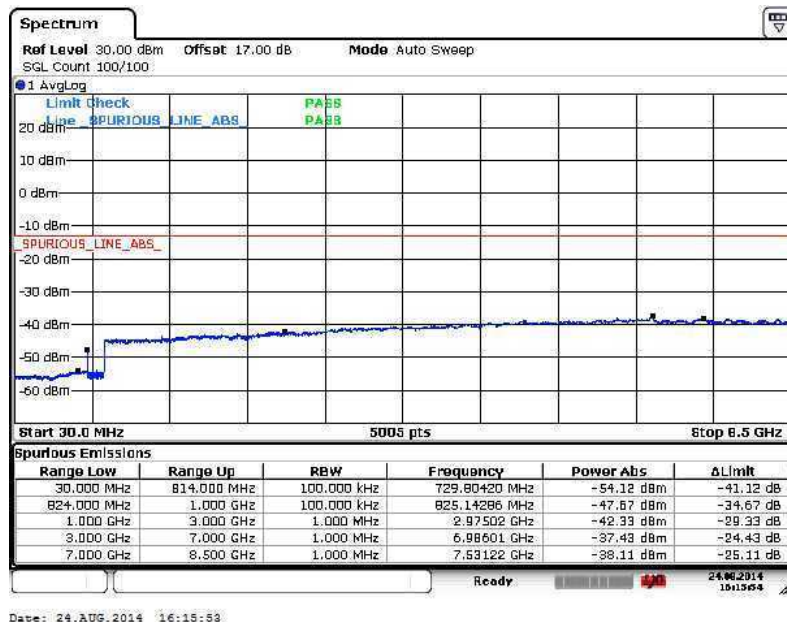



Band :	LTE Band 26	Channel :	CH26715 (Low)
Band Width :	5MHz		

QPSK (RB Size 1, RB Offset 0)

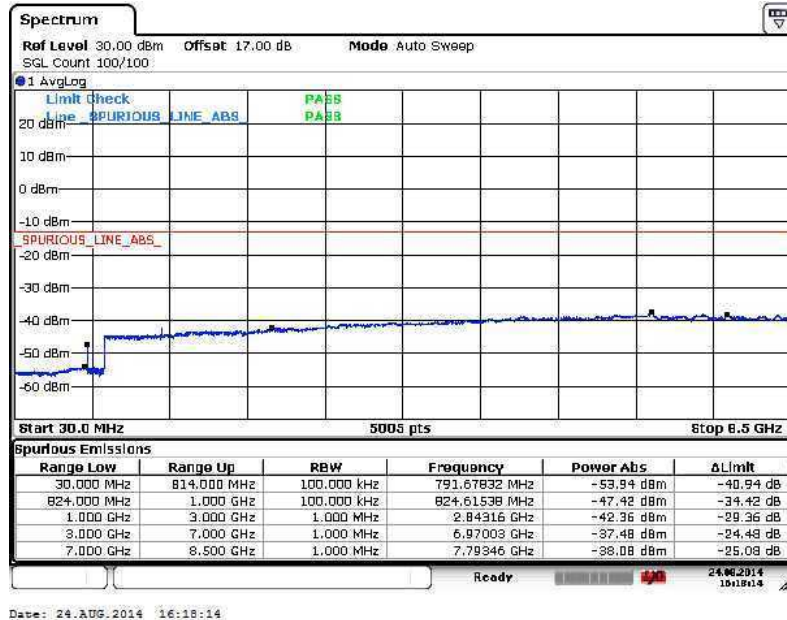

16QAM (RB Size 1, RB Offset 24)

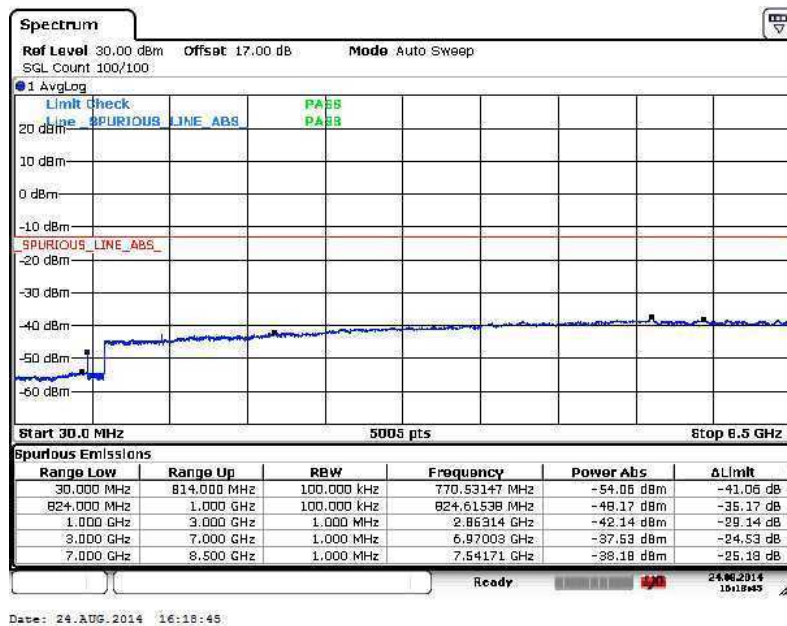



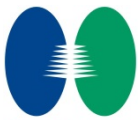

Band :	LTE Band 26	Channel :	CH26740 (Middle)
Band Width :	5MHz		

QPSK (RB Size 1, RB Offset 0)

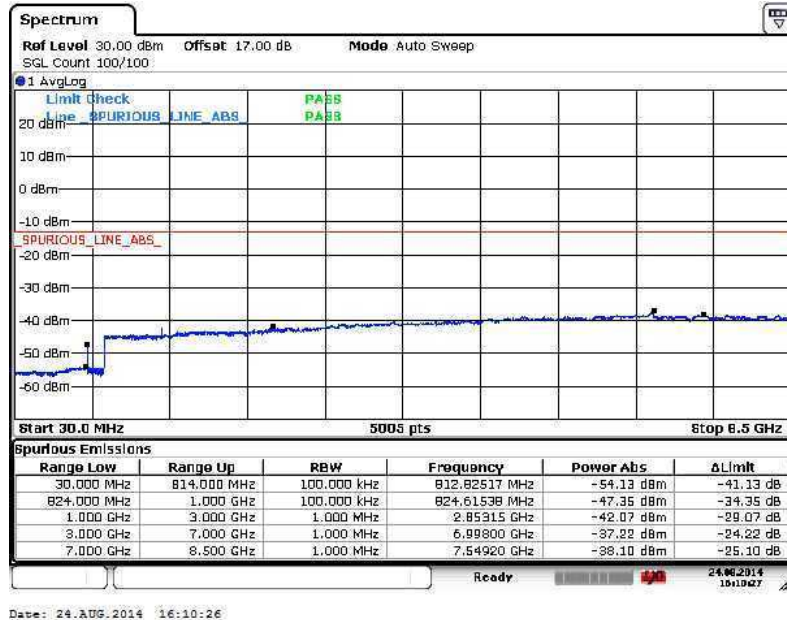

Date: 24.AUG.2014 16:10:26

16QAM (RB Size 1, RB Offset 0)



Date: 24.AUG.2014 16:09:54



Band :	LTE Band 26	Channel :	CH26765 (High)
Band Width :	5MHz		

QPSK (RB Size 1, RB Offset 12)

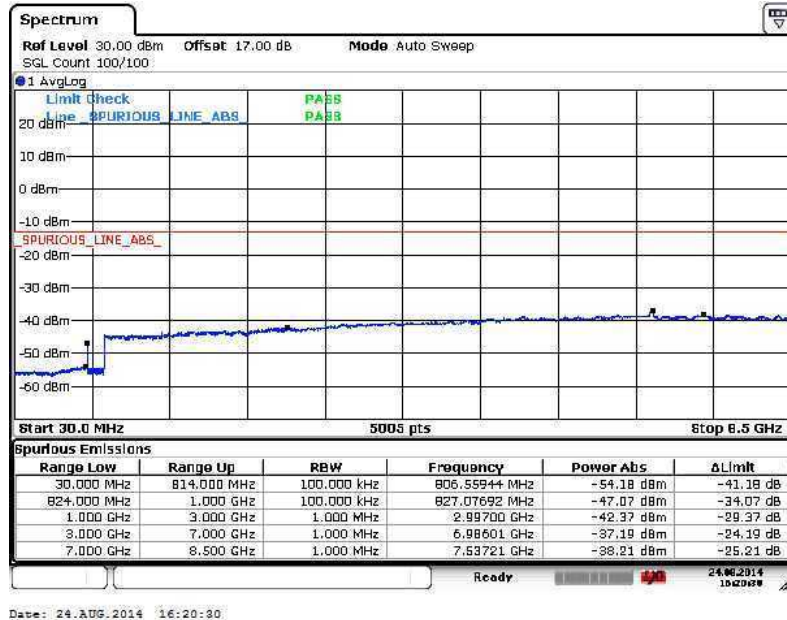

16QAM (RB Size 1, RB Offset 12)

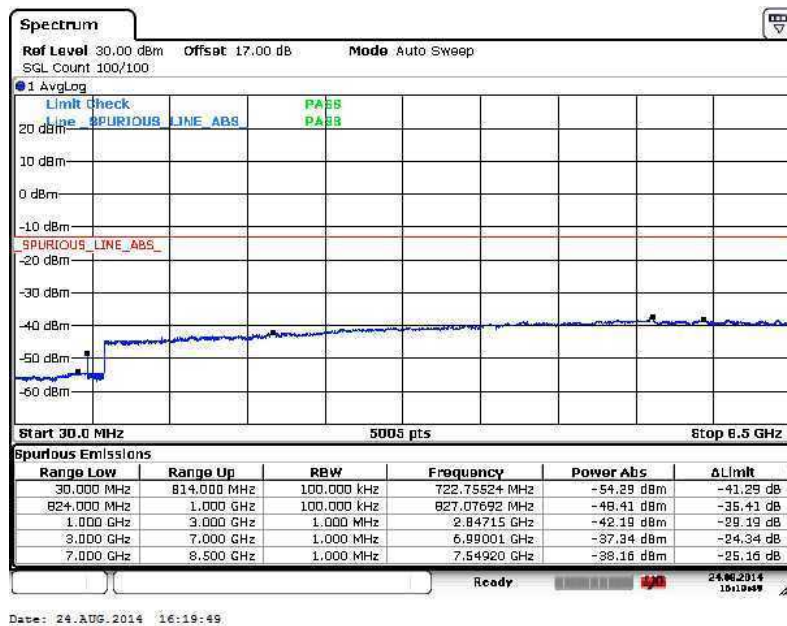



Band :	LTE Band 26	Channel :	CH26740 (Middle)
Band Width :	10MHz		

QPSK (RB Size 1, RB Offset 49)

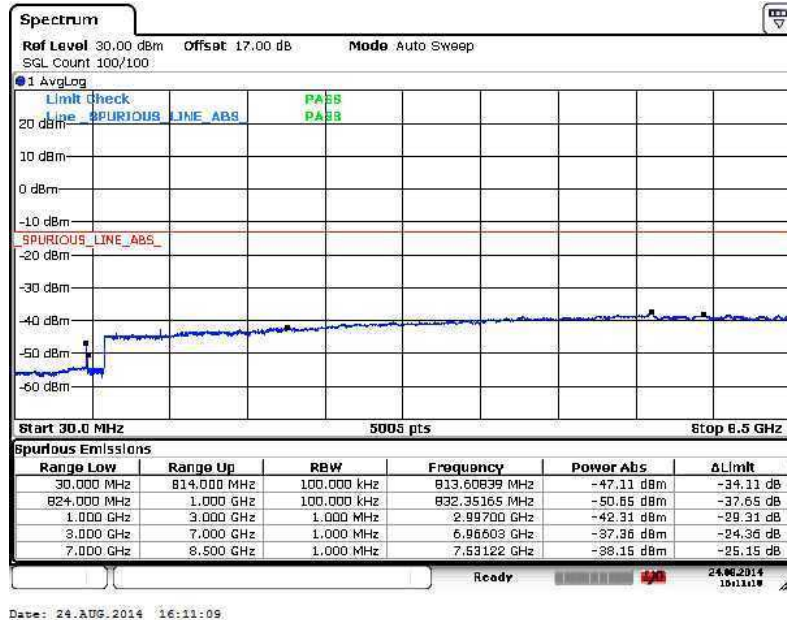

16QAM (RB Size 1, RB Offset 0)

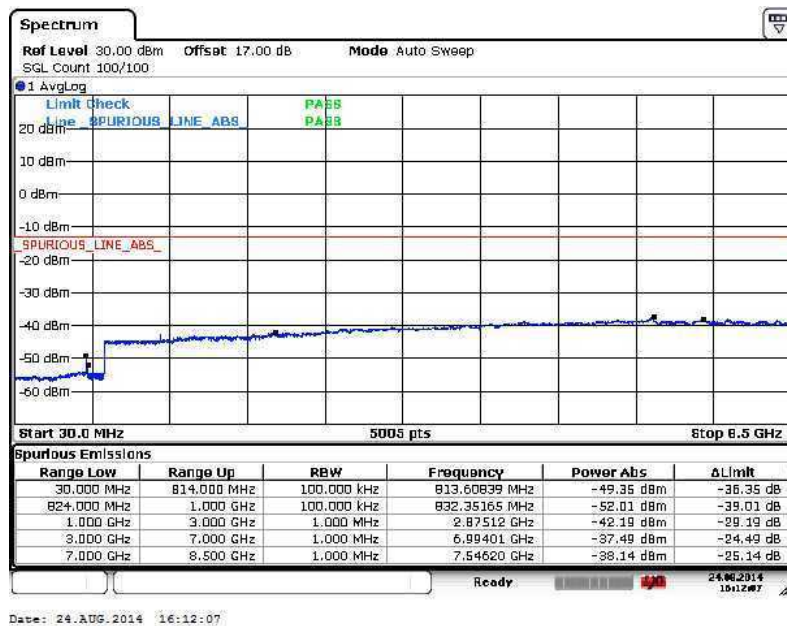

## 3.5 Field Strength of Spurious Radiation Measurement

### 3.5.1 Description of Field Strength of Spurious Radiated Measurement

The radiated spurious emission was measured by substitution method according to ANSI / TIA / EIA-603-C-2004. The power of any emission FCC Part 90.691 on any frequency removed from the assigned frequency by more than 250 percent of the authorized bandwidth at least  $43 + 10 \log (P)$  dB. The spectrum is scanned from 30 MHz up to a frequency including its 10th harmonic.

The power of any emission outside of the authorized operating frequency ranges must be attenuated below the transmitter power (P) by a factor of at least  $43+10\log_{10}(P[\text{Watts}])$  dB. The spectrum is scanned from 30 MHz up to a frequency including its 10th harmonic.

### 3.5.2 Measuring Instruments

The measuring equipment is listed in the section 4 of this test report.

### 3.5.3 Test Procedures

1. The EUT was placed on a rotatable wooden table with 0.8 meter about ground.
2. The EUT was set 3 meters from the receiving antenna, which was mounted on the antenna tower.
3. The table was rotated 360 degrees to determine the position of the highest spurious emission.
4. The height of the receiving antenna is varied between one meter and four meters to search the maximum spurious emission for both horizontal and vertical polarizations.
5. Make the measurement with the spectrum analyzer's RBW = 1MHz, VBW = 3MHz, Sweep = 500ms, Taking the record of maximum spurious emission.
6. A horn antenna was substituted in place of the EUT and was driven by a signal generator.
7. Tune the output power of signal generator to the same emission level with EUT maximum spurious emission.
8. Taking the record of output power at antenna port.
9. Repeat step 7 to step 8 for another polarization.
10.  $\text{EIRP (dBm)} = \text{S.G. Power} - \text{Tx Cable Loss} + \text{Tx Antenna Gain}$
11.  $\text{ERP (dBm)} = \text{EIRP} - 2.15$
12. The RF fundamental frequency should be excluded against the limit line in the operating frequency band.
13. The limit line is derived from  $43 + 10\log(P)$  dB below the transmitter power P(Watts)  
 $= P(\text{W}) - [43 + 10\log(P)] (\text{dB})$   
 $= [30 + 10\log(P)] (\text{dBm}) - [43 + 10\log(P)] (\text{dB})$   
 $= -13\text{dBm}.$

### 3.5.4 Test Setup

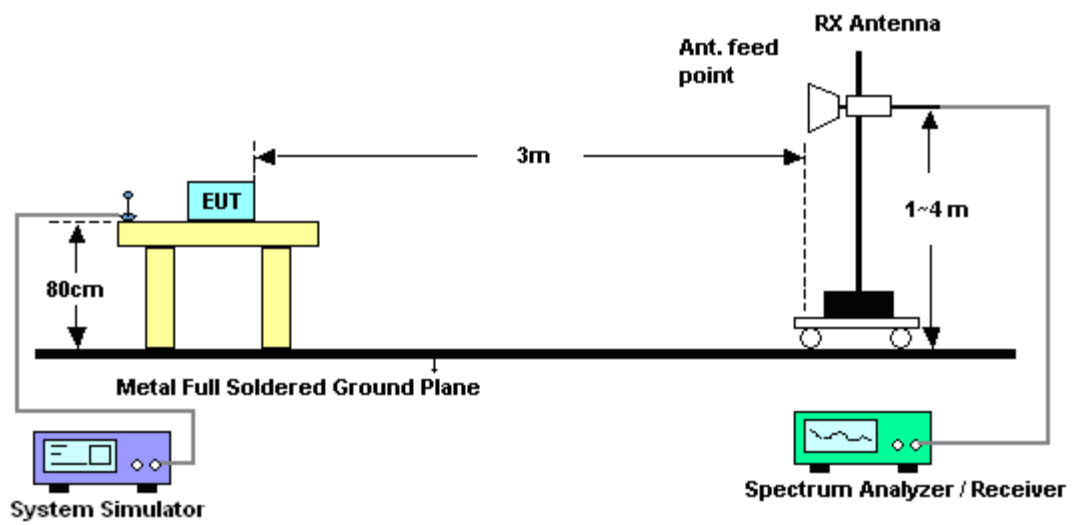
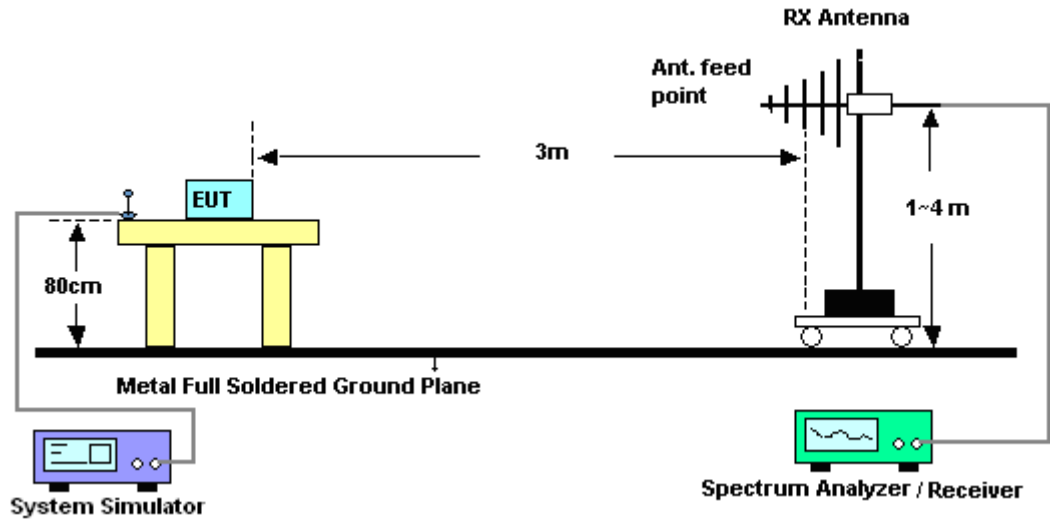



**3.5.5 Test Result of Field Strength of Spurious Radiated**

<b>Band :</b>	LTE Band 26				<b>Temperature :</b>	22~23°C			
<b>Test Mode :</b>	1.4MHz QPSK RB Size 1 Offset 0				<b>Relative Humidity :</b>	42~43%			
<b>Test Engineer :</b>	Star Wei				<b>Polarization :</b>	Horizontal			
<b>Remark :</b>	Spurious emissions within 30-10th harmonic were found more than 20dB below limit line.								
Frequency ( MHz )	ERP ( dBm )	Limit ( dBm )	Over Limit ( dB )	SPA Reading ( dBm )	S.G. Power ( dBm )	TX Cable loss ( dB )	TX Antenna Gain ( dBi )	Polarization ( H/V )	Result
1638	-60.59	-13	-47.59	-55.78	-61.24	0.57	3.37	H	Pass
2456	-63.39	-13	-50.39	-62.06	-65.62	0.78	5.16	H	Pass
3274	-65.78	-13	-52.78	-65.41	-69.42	0.87	6.66	H	Pass

<b>Band :</b>	LTE Band 26				<b>Temperature :</b>	22~23°C			
<b>Test Mode :</b>	1.4MHz QPSK RB Size 1 Offset 0				<b>Relative Humidity :</b>	42~43%			
<b>Test Engineer :</b>	Star Wei				<b>Polarization :</b>	Vertical			
<b>Remark :</b>	Spurious emissions within 30-10th harmonic were found more than 20dB below limit line.								
Frequency ( MHz )	ERP ( dBm )	Limit ( dBm )	Over Limit ( dB )	SPA Reading ( dBm )	S.G. Power ( dBm )	TX Cable loss ( dB )	TX Antenna Gain ( dBi )	Polarization ( H/V )	Result
1638	-57.64	-13	-44.64	-58.11	-58.29	0.57	3.37	V	Pass
2456	-56.96	-13	-43.96	-60.98	-59.19	0.78	5.16	V	Pass
3274	-66.17	-13	-53.17	-67.23	-69.81	0.87	6.66	V	Pass



<b>Band :</b>	LTE Band 26	<b>Temperature :</b>	22~23°C						
<b>Test Mode :</b>	3MHz QPSK RB Size 1 Offset 0	<b>Relative Humidity :</b>	42~43%						
<b>Test Engineer :</b>	Star Wei	<b>Polarization :</b>	Horizontal						
<b>Remark :</b>	Spurious emissions within 30-10th harmonic were found more than 20dB below limit line.								
Frequency ( MHz )	ERP ( dBm )	Limit ( dBm )	Over Limit ( dB )	SPA Reading ( dBm )	S.G. Power ( dBm )	TX Cable loss ( dB )	TX Antenna Gain ( dBi )	Polarization ( H/V )	Result
1636	-59.82	-13	-46.82	-55.27	-60.47	0.57	3.37	H	Pass
2454	-61.54	-13	-48.54	-60.21	-63.77	0.78	5.16	H	Pass
3270	-66.24	-13	-53.24	-65.87	-69.88	0.87	6.66	H	Pass

<b>Band :</b>	LTE Band 26	<b>Temperature :</b>	22~23°C						
<b>Test Mode :</b>	3MHz QPSK RB Size 1 Offset 0	<b>Relative Humidity :</b>	42~43%						
<b>Test Engineer :</b>	Star Wei	<b>Polarization :</b>	Vertical						
<b>Remark :</b>	Spurious emissions within 30-10th harmonic were found more than 20dB below limit line.								
Frequency ( MHz )	ERP ( dBm )	Limit ( dBm )	Over Limit ( dB )	SPA Reading ( dBm )	S.G. Power ( dBm )	TX Cable loss ( dB )	TX Antenna Gain ( dBi )	Polarization ( H/V )	Result
1636	-57.61	-13	-44.61	-58.09	-58.26	0.57	3.37	V	Pass
2454	-57.77	-13	-44.77	-61.34	-60.00	0.78	5.16	V	Pass
3270	-65.07	-13	-52.07	-66.13	-68.71	0.87	6.66	V	Pass





<b>Band :</b>	LTE Band 26	<b>Temperature :</b>	22~23°C						
<b>Test Mode :</b>	5MHz QPSK RB Size 1 Offset 0	<b>Relative Humidity :</b>	42~43%						
<b>Test Engineer :</b>	Star Wei	<b>Polarization :</b>	Horizontal						
<b>Remark :</b>	Spurious emissions within 30-10th harmonic were found more than 20dB below limit line.								
Frequency ( MHz )	ERP ( dBm )	Limit ( dBm )	Over Limit ( dB )	SPA Reading ( dBm )	S.G. Power ( dBm )	TX Cable loss ( dB )	TX Antenna Gain ( dBi )	Polarization ( H/V )	Result
1634	-58.75	-13	-45.75	-54.76	-59.40	0.57	3.37	H	Pass
2452	-62.12	-13	-49.12	-60.79	-64.35	0.78	5.16	H	Pass
3266	-65.90	-13	-52.90	-65.53	-69.54	0.87	6.66	H	Pass

<b>Band :</b>	LTE Band 26	<b>Temperature :</b>	22~23°C						
<b>Test Mode :</b>	5MHz QPSK RB Size 1 Offset 0	<b>Relative Humidity :</b>	42~43%						
<b>Test Engineer :</b>	Star Wei	<b>Polarization :</b>	Vertical						
<b>Remark :</b>	Spurious emissions within 30-10th harmonic were found more than 20dB below limit line.								
Frequency ( MHz )	ERP ( dBm )	Limit ( dBm )	Over Limit ( dB )	SPA Reading ( dBm )	S.G. Power ( dBm )	TX Cable loss ( dB )	TX Antenna Gain ( dBi )	Polarization ( H/V )	Result
1634	-55.09	-13	-42.09	-56.46	-55.74	0.57	3.37	V	Pass
2452	-56.66	-13	-43.66	-60.80	-58.89	0.78	5.16	V	Pass
3266	-64.25	-13	-51.25	-65.31	-67.89	0.87	6.66	V	Pass



<b>Band :</b>	LTE Band 26	<b>Temperature :</b>	22~23°C						
<b>Test Mode :</b>	10MHz QPSK RB Size 1 Offset 0	<b>Relative Humidity :</b>	42~43%						
<b>Test Engineer :</b>	Star Wei	<b>Polarization :</b>	Horizontal						
<b>Remark :</b>	Spurious emissions within 30-10th harmonic were found more than 20dB below limit line.								
Frequency ( MHz )	ERP ( dBm )	Limit ( dBm )	Over Limit ( dB )	SPA Reading ( dBm )	S.G. Power ( dBm )	TX Cable loss ( dB )	TX Antenna Gain ( dBi )	Polarization ( H/V )	Result
1628	-58.18	-13	-45.18	-54.46	-58.83	0.57	3.37	H	Pass
2444	-66.58	-13	-53.58	-65.25	-68.81	0.78	5.16	H	Pass
3258	-64.75	-13	-51.75	-64.38	-68.39	0.87	6.66	H	Pass

<b>Band :</b>	LTE Band 26	<b>Temperature :</b>	22~23°C						
<b>Test Mode :</b>	10MHz QPSK RB Size 1 Offset 0	<b>Relative Humidity :</b>	42~43%						
<b>Test Engineer :</b>	Star Wei	<b>Polarization :</b>	Vertical						
<b>Remark :</b>	Spurious emissions within 30-10th harmonic were found more than 20dB below limit line.								
Frequency ( MHz )	ERP ( dBm )	Limit ( dBm )	Over Limit ( dB )	SPA Reading ( dBm )	S.G. Power ( dBm )	TX Cable loss ( dB )	TX Antenna Gain ( dBi )	Polarization ( H/V )	Result
1628	-48.50	-13	-35.50	-51.61	-49.15	0.57	3.37	V	Pass
2444	-57.29	-13	-44.29	-61.13	-59.52	0.78	5.16	V	Pass
3258	-62.67	-13	-49.67	-63.73	-66.31	0.87	6.66	V	Pass



## **3.6 Frequency Stability Measurement**

### **3.6.1 Description of Frequency Stability Measurement**

The frequency stability shall be measured by variation of ambient temperature and variation of primary supply voltage to ensure that the fundamental emission stays within the authorized frequency block. The frequency stability of the transmitter shall be maintained within  $\pm 0.00025\%$  ( $\pm 2.5\text{ppm}$ ) of the center frequency according to FCC Part 90.213.

### **3.6.2 Measuring Instruments**

The measuring equipment is listed in the section 4 of this test report.

### **3.6.3 Test Procedures for Temperature Variation**

1. The EUT was set up in the thermal chamber and connected with the base station.
2. With power OFF, the temperature was decreased to  $-30^{\circ}\text{C}$  and the EUT was stabilized for three hours. Power was applied and the maximum change in frequency was recorded within one minute.
3. With power OFF, the temperature was raised in  $10^{\circ}\text{C}$  step up to  $50^{\circ}\text{C}$ . The EUT was stabilized at each step for at least half an hour. Power was applied and the maximum frequency change was recorded within one minute.

### **3.6.4 Test Procedures for Voltage Variation**

1. The EUT was placed in a temperature chamber at  $25\pm 5^{\circ}\text{C}$  and connected with the base station.
2. The power supply voltage to the EUT was varied from BEP to 115% of the nominal value measured at the input to the EUT.
3. The variation in frequency was measured for the worst case.

### 3.6.5 Test Setup

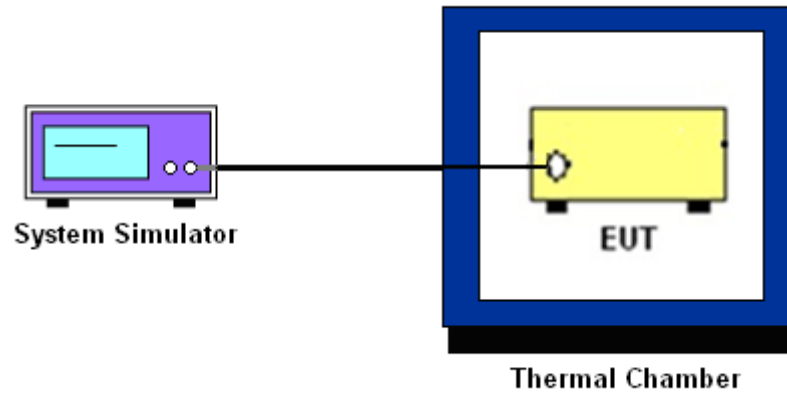

**3.6.6 Test Result of Temperature Variation**

Band :	LTE Band 26 (QPSK)	Limit (ppm) :	2.5
Temperature (°C)	BW 10MHz		Result
	Deviation (ppm)		
50	0.0012		PASS
40	0.0000		
30	0.0012		
20(Ref.)	0.0000		
10	0.0049		
0	0.0024		
-10	0.0012		
-20	0.0049		
-30	0.0037		

**3.6.7 Test Result of Voltage Variation**

Band	Bandwidth	Voltage (Volt)	Deviation (ppm)	Limit (ppm)	Result
LTE Band 26 (QPSK)	10M	3.5	0.0232	2.5	PASS
		Normal	0.0000		
		4.35	0.0232		

**Remark:**

1. Normal Voltage = 3.8V.
2. The manufacturer declared that the EUT could work properly between voltage 3.5V ~ 4.35V.



## 4 List of Measuring Equipment

Instrument	Manufacturer	Model No.	Serial No.	Characteristics	Calibration Date	Test Date	Due Date	Remark
Spectrum Analyzer	R&S	FSV40	101078	10Hz~40GHz	May 08, 2014	Aug. 24, 2014	May 07, 2015	Conducted (TH01-SZ)
Thermal Chamber	Hongzhangroup	LP-150U	HD20120425	-40°C~150°C	Feb. 21, 2014	Aug. 24, 2014	Feb. 20, 2015	Conducted (TH01-SZ)
EMI Test Receiver	R&S	ESCI	100534	9kHz~3GHz	Nov. 05, 2013	Aug. 24, 2014	Nov. 04, 2014	Radiation (03CH01-KS)
Spectrum Analyzer	R&S	FSP30	101399	9kHz~30GHz	May 04, 2014	Aug. 24, 2014	May 03, 2015	Radiation (03CH01-KS)
Bilog Antenna	SCHAFFNER	CBL6112D	23182	25MHz~2GHz	Jan. 08, 2014	Aug. 24, 2014	Jan. 07, 2015	Radiation (03CH01-KS)
Double Ridge Horn	ETS-Lindgren	3117	75959	1GHz~18GHz	Jan. 08, 2014	Aug. 24, 2014	Jan. 07, 2015	Radiation (03CH01-KS)
Active Horn Antenna	com-power	AHA-118	701030	1GHz~18GHz	Nov. 18, 2013	Aug. 24, 2014	Nov. 17, 2014	Radiation (03CH01-KS)
Amplifier	com-power	PA-103A	161073	1MHz~1GHz	May 04, 2014	Aug. 24, 2014	May 03, 2015	Radiation (03CH01-KS)
Amplifier	Agilent	8449B	3008A02371	1GHz~26.5GHz	Dec. 10, 2013	Aug. 24, 2014	Dec. 09, 2014	Radiation (03CH01-KS)
AC Power Source	Chroma	61601	F104090004	N/A	NCR	Aug. 24, 2014	NCR	Radiation (03CH01-KS)
Turn Table	MF	MF7802	N/A	0~360 degree	NCR	Aug. 24, 2014	NCR	Radiation (03CH01-KS)
Antenna Mast	MF	MF7802	N/A	1 m~4 m	NCR	Aug. 24, 2014	NCR	Radiation (03CH01-KS)



## 5 Uncertainty of Evaluation

### Uncertainty of Radiated Emission Measurement (30 MHz ~ 1000 MHz)

Measuring Uncertainty for a Level of Confidence of 95% ( $U = 2Uc(y)$ )	2.5
---	-----