



FCC PART 15C TEST REPORT FOR CERTIFICATION
On Behalf of

BYD Precision Manufacture Co., Ltd

Tablet PC

Model Number: T10COT

FCC ID: ZW9DIV80039668

Prepared for : BYD Precision Manufacture Co., Ltd
Floor 1, A3 Workshop, Floor 3, A1 Workshop, Floor 4,
A10 Workshop, No. 3001, Baohe Road, Baolong
Industrial, Longgang, Shenzhen, P.R., China

Prepared By : Audix Technology (Shenzhen) Co., Ltd.
No. 6, Ke Feng Rd., 52 Block,
Shenzhen Science & Industrial Park,
Nantou, Shenzhen, Guangdong, China

Tel: (0755) 26639496

Report Number : ACS-F11164
Date of Test : Jun.28~Aug.03, 2011
Date of Report : Aug.05, 2011

TABLE OF CONTENTS

Description	Page
1. SUMMARY OF STANDARDS AND RESULTS.....	1-1
1.1. Description of Standards and Results	1-1
2. GENERAL INFORMATION	2-1
2.1. Description of Device (EUT).....	2-1
2.2. Specification information of EUT.....	2-2
2.3. Test Mode of PC Configuration.....	2-3
2.4. Tested Supporting System Details	2-4
2.5. EUT Configuration and operation conditions for test.....	2-4
2.6. Test Facility	2-5
2.7. Measurement Uncertainty (95% confidence levels, k=2)	2-6
3. POWER LINE CONDUCTED EMISSION TEST	3-1
3.1. Test Equipments.....	3-1
3.2. Block Diagram of Test Setup.....	3-1
3.3. Power Line Conducted Emission Test Limits.....	3-1
3.4. Configuration of EUT on Test	3-2
3.5. Operating Condition of EUT.....	3-2
3.6. Test Procedure.....	3-2
3.7. Power Line Conducted Emission Test Results	3-2
4. RADIATED EMISSION TEST	4-1
4.1. Test Equipment	4-1
4.2. Block Diagram of Test Setup.....	4-1
4.3. Radiated Emission Limit Standard: FCC 15.209	4-2
4.4. EUT Configuration on Test.....	4-3
4.5. Operating Condition of EUT.....	4-3
4.6. Test Procedure.....	4-3
4.7. Radiated Emission Test Results	4-3
5. CONDUCTED SPURIOUS EMISSIONS.....	5-1
5.1. Test Equipment	5-1
5.2. Limit.....	5-1
5.3. Test Procedure.....	5-1
5.4. Test result.....	5-1
6. CARRIER FREQUENCY SEPARATION TEST	6-1
6.1. Test Equipment	6-1
6.2. Limit.....	6-1
6.3. Test Results	6-1
7. 20 DB BANDWIDTH TEST	7-1
7.1. Test Equipment	7-1
7.2. Limit.....	7-1
7.3. Test Results	7-1
8. NUMBER OF HOPPING FREQUENCY TEST	8-1
8.1. Test Equipment	8-1
8.2. Limit.....	8-1
8.3. Test Results	8-1
9. DWELL TIME	9-1

9.1.	Test Equipment	9-1
9.2.	Limit.....	9-1
9.3.	Test Results	9-1
10.	MAXIMUM PEAK OUTPUT POWER TEST	10-1
10.1.	Test Equipment	10-1
10.2.	Limit.....	10-1
10.3.	Test Procedure.....	10-1
10.4.	Test Results	10-2
11.	BAND EDGE COMPLIANCE TEST	11-1
11.1.	Test Equipment	11-1
11.2.	Limit.....	11-1
11.3.	Test Produce	11-1
11.4.	Test Results	11-2
12.	DEVIATION TO TEST SPECIFICATIONS.....	12-1
13.	PHOTOGRAPH OF TEST	13-1
13.1.	Photos of Power Line Conducted Emission Test.....	13-1
13.2.	Photos of Radiated Emission Test (30-1000MHz)	13-1
14.	PHOTOS OF THE EUT	14-1



FCC ID: ZW9DIV80039668

TEST REPORT CERTIFICATION

Applicant : BYD Precision Manufacture Co., Ltd
 Manufacturer : BYD Precision Manufacture Co., Ltd
 EUT Description : Tablet PC
 FCC ID : ZW9DIV80039668

(A) MODEL NO. : T10COT
 (B) SERIAL NO. : N/A
 (C) POWER SUPPLY : AC 100~ 240V; 50/60Hz
 (D) TEST VOLTAGE : DC 19V From Adapter Input, AC 120V/60Hz

Tested for comply with:
 FCC Rules and Regulations Part 15 Subpart C:2008
 Test procedure used:
 ANSI C63.10:2009

The device described above is tested by AUDIX TECHNOLOGY (SHENZHEN) CO., LTD. to confirm comply with all the FCC Part 15 Subpart C requirements.

The test results are contained in this test report and AUDIX TECHNOLOGY (SHENZHEN) CO., LTD. is assumed full responsibility for the accuracy and completeness of these tests. This report contains data that are not covered by the NVLAP accreditation. Also, this report shows that the Equipment Under Test (EUT) is to be technically compliant with the FCC requirements.

This Report is made under FCC Part 2.1075. No modifications were required during testing to bring this product into compliance.

This report applies to above tested sample only. This report shall not be reproduced in part without written approval of AUDIX TECHNOLOGY (SHENZHEN) CO., LTD.

The report must not be used by the client to claim product certification, approval, or endorsement by NVLAP, NIST, or any agency of the federal government.

Date of Test : Jun.28~ Aug.03, 2011 Report of date: Aug.05, 2011

Prepared by : Blove Ye Reviewer by : Sunny Lu
 Blove Ye/ Assistant Sunny Lu/ Supervisor



Approved & Authorized Signer : Ken Lu / Manager

1. SUMMARY OF STANDARDS AND RESULTS

1.1. Description of Standards and Results

The EUT have been tested according to the applicable standards as referenced below.

EMISSION		
Description of Test Item	Standard	Results
Power Line Conducted Emission Test	FCC Part 15: 15.207 ANSI C63.10 :2009	PASS
Radiated Emission Test	FCC Part 15: 15.209 FCC Part 15: 15.247(d) ANSI C63.10 :2009	PASS
Conducted Spurious Emissions	FCC Part 15: 15.247(a)(1) ANSI C63.10 :2009	PASS
Carrier Frequency Separation Test	FCC Part 15: 15.247(a)(1) ANSI C63.10 :2009	PASS
20dB Bandwidth Test	FCC Part 15: 15.215 ANSI C63.10 :2009	PASS
Number Of Hopping Frequency Test	FCC Part 15: 15.247(a)(1)(iii) ANSI C63.10 :2009	PASS
Dwell Time Test	FCC Part 15: 15.247(a)(1)(iii) ANSI C63.10 :2009	PASS
Maximum Peak Output Power Test	FCC Part 15: 15.247(b)(1)\ ANSI C63.10 :2009	PASS
Band Edge Compliance Test	FCC Part 15: 15.247(d) ANSI C63.10 :2009	PASS

N/A is an abbreviation for Not Applicable.

2. GENERAL INFORMATION

2.1. Description of Device (EUT)

Product Name	: Tablet PC
Model Number	: T10COT
FCC ID	: ZW9DIV80039668
Operation frequency	: 2402MHz-2480MHz
Antenna	: IFA, 2.0dBi PK gain
Modulation	: GFSK, $\pi/4$ DQPSK, 8-DPSK
Power Supply	: AC 100~240V; 50/60Hz (Note: Batteries were full charged for all the test.)
Applicant	: BYD Precision Manufacture Co., Ltd Floor 1, A3 Workshop, Floor 3, A1 Workshop, Floor 4, A10 Workshop, No. 3001, Baohe Road, Baolong Industrial, Longgang, Shenzhen, P.R., China
Manufacturer	: BYD Precision Manufacture Co., Ltd Floor 1, A3 Workshop, Floor 3, A1 Workshop, Floor 4, A10 Workshop, No. 3001, Baohe Road, Baolong Industrial, Longgang, Shenzhen, P.R., China
Power Adapter	: Manufacturer: DARFON, M/N: BA01-J INPUT: 100-240V~1A 50-60Hz OUTPUT: 19V, 2.1A Cable: Shielded, Undetachable, 2.7m(with one core)
Power Cord	: Unshielded, Detachable, 1.8 (3pins)
Date of Test	: Jun.28~Aug.03, 2011
Date of Receipt	: Jun.27, 2011
Sample Type	: Prototype production

2.2.Specification information of EUT

Item	Part Number	Detail	Supplier
SSD	SDSA4DH-032G-YYYY	SSD	SANDISK
	SSE032GTMC0-S50	SSD	PHISON
Antenna	10610114-00	3G Antenna	BYD
	4003632	WIFI Antenna	Ethertronics
Module	M101NWT2	LCD	IVO
	B101AW02V0	LCD	AUO
	RTL8188CUS - BC8_WBX	Wifi+BT	CastleNet
	10515265-00	Lion-battery	BYD2
Adapter	BA01-J0T	Adapter	Darfon
Thermal Module	D101-0100-A0	Thermal Module	DWPH
CMOS Battery	C2020-0621	CMOS Battery	BYD
	CR2016W4.0VJ1KY	CMOS Battery	Lisun
	CR2016-SUZHOU(JLF)-B	CMOS Battery	LONG TRUMP INTERNATIONAL CORP
Power supply cord	E301AC501-N221	Power supply cord	TONGYUAN
	300+705-1.1MBK	Power supply cord	LEONI
	U303C501-N221	Power supply cord	TONGYUAN
	LAP-31+705-1.1MBK	Power supply cord	LEONI

2.3. Test Mode of PC Configuration

Item	Part Number	Detail	Supplier
SSD	SDSA4DH-032G-YYYY	SSD	SANDISK
	SSE032GTMC0-S50	SSD	PHISON
Antenna	10610114-00	3G Antenna	BYD
	4003632	WIFI Antenna	Ethertronics
Module	M101NWT2	LCD	IVO
	B101AW02V0	LCD	AUO
	RTL8188CUS - BC8_WBX	Wifi+BT	CastleNet
	10515265-00	Lion-battery	BYD2
Adapter	BA01-J0T	Adapter	Darfon
Thermal Module	D101-0100-A0	Thermal Module	DWPH
CMOS Battery	C2020-0621	CMOS Battery	BYD
	CR2016W4.0VJ1KY	CMOS Battery	Lisun
	CR2016-SUZHOU(JLF)-B	CMOS Battery	LONG TRUMP INTERNATIONAL CORP
Power supply cord	E301AC501-N221	Power supply cord	TONGYUAN
	300+705-1.1MBK	Power supply cord	LEONI
	U303C501-N221	Power supply cord	TONGYUAN
	LAP-31+705-1.1MBK	Power supply cord	LEONI

2.4. Tested Supporting System Details

No.	Description	ACS No.	Manufacturer	Model	Serial Number	Approved type
1.	Monitor	ACS-EMC-LM04R	DELL	1907FPt	CN-009759-71 618-6AP-ACP P	<input checked="" type="checkbox"/> FCC DoC <input checked="" type="checkbox"/> BSMI ID: R3A002
		Power Cord: Unshielded, Detachable, 1.8m HDMI Cable: Shielded, Detachable, 2.0m				
2.	USB Mouse	ACS-EMC-M04R	DELL	M056UO	512024282	<input checked="" type="checkbox"/> FCC DoC <input checked="" type="checkbox"/> BSMI ID: R41108
		Power Cord: shielded, Undetachable, 1.8m				
3.	USB Keyboard	ACS-EMC- K04R	DELL	SK-8115	CN-ODJ313-7 1616-6BB-049 J	<input checked="" type="checkbox"/> FCC DoC <input checked="" type="checkbox"/> BSMI ID: T3A002
		Power Cord: shielded, Undetachable, 2.0m				
4.	Headphone	ACS-EMC-EP01	OVANN	OV880V	N/A	<input type="checkbox"/> FCC ID <input type="checkbox"/> BSMI ID
		Cable: Shielded, Undetachabled, 4.0m				

2.5. EUT Configuration and operation conditions for test.

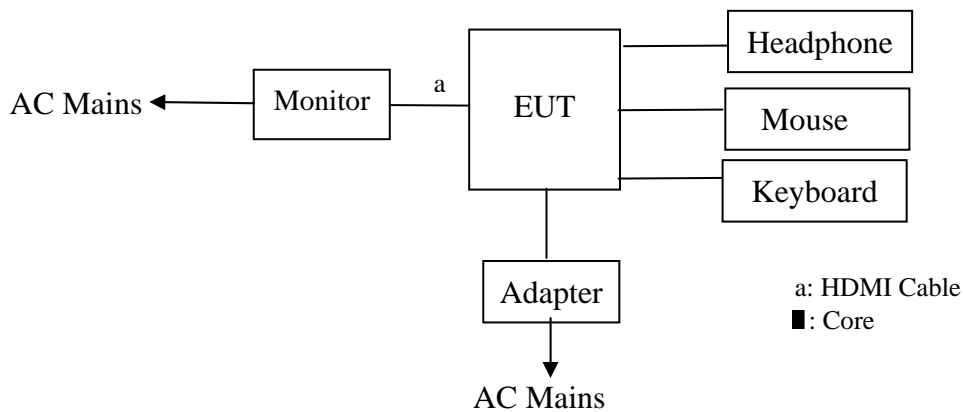

(EUT: Tablet PC)

2.6. Test Facility

Site Description

Name of Firm : Audix Technology (Shenzhen) Co., Ltd.
No. 6, Ke Feng Rd., 52 Block, Shenzhen
Science & Industrial Park, Nantou,
Shenzhen, Guangdong, China

3m Anechoic Chamber : Certificated by FCC, USA
Registration Number: 90454
Valid Date: Mar.31, 2012

3m & 10m Anechoic Chamber : Certificated by FCC, USA
Registration Number: 794232
Valid Date: Dec.30, 2012

EMC Lab. : Certificated by Industry Canada
Registration Number: IC 5183A-1
Valid Date: Jun.13, 2014

Certificated by DAkkS, Germany
Registration No: D-PL-12151-01-01
Valid Date: Feb.01, 2014

Accredited by NVLAP, USA
NVLAP Code: 200372-0
Valid Date: Mar.31, 2012

2.7.Measurement Uncertainty (95% confidence levels, k=2)

Test Item	Uncertainty
Uncertainty for Conduction emission test in No. 1 Conduction	3.2 dB(150kHz to 30MHz)
Uncertainty for Radiation Emission test in 3m chamber	3.6 dB(30~200MHz, Polarize: H)
	3.7 dB(30~200MHz, Polarize: V)
	4.0 dB(200M~1GHz, Polarize: H)
	3.7 dB(200M~1GHz, Polarize: V)
Uncertainty for Radiated Spurious Emission test in RF chamber	3.57dB
Uncertainty for Conduction Spurious emission test	2.00 dB
Uncertainty for Output power test	0.73 dB
Uncertainty for Power density test	2.00 dB
Uncertainty for Frequency range test	7×10^{-8}
Uncertainty for Bandwidth test	83 kHz
Uncertainty for DC power test	0.038 %
Uncertainty for test site temperature and humidity	0.6°C
	3%

3. POWER LINE CONDUCTED EMISSION TEST

3.1. Test Equipments

Item	Equipment	Manufacturer	Model No.	Serial No.	Last Cal.	Cal. Interval
1.	Test Receiver	Rohde & Schwarz	ESHS10	838693/001	Nov.05, 10	1 Year
2.	L.I.S.N.#1	Rohde & Schwarz	ESH2-Z5	834066/011	Nov.05, 11	1 Year
3.	L.I.S.N.#3	Kyoritsu	KNW-242C	8-1920-1	May.08, 11	1 Year
4.	Terminator	Hubersuhner	50Ω	No. 1	May.08, 11	1 Year
5.	RF Cable	Fujikura	3D-2W	LISN Cable 1#	May.08, 11	1 Year
6.	Coaxial Switch	Anritsu	MP59B	M55367	May.08, 11	1 Year
7.	Passive Probe	Rohde & Schwarz	ESH2-Z3	299.7810.52	May.08, 11	1 Year
8.	Pulse Limiter	Rohde & Schwarz	ESH3-Z2	100341	May.08, 11	1 Year

3.2. Block Diagram of Test Setup

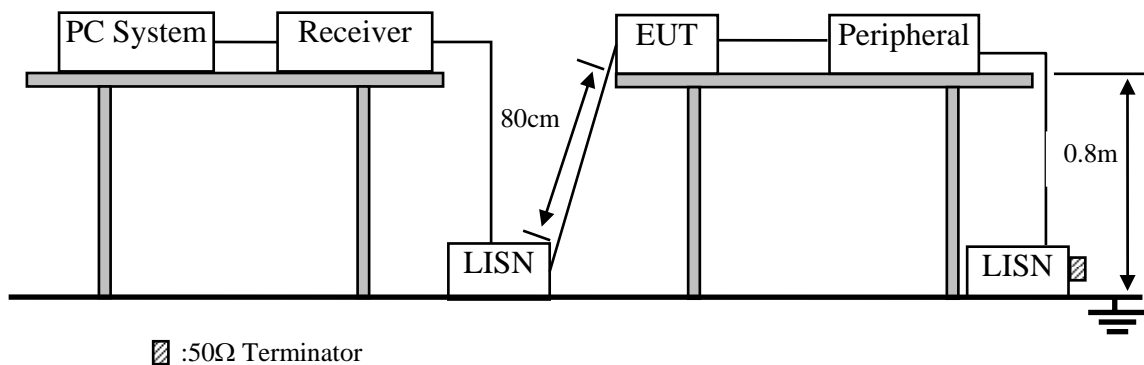

3.3. Power Line Conducted Emission Test Limits

Frequency	Maximum RF Line Voltage	
	Quasi-Peak Level dB(μV)	Average Level dB(μV)
150kHz ~ 500kHz	66 ~ 56*	56 ~ 46*
500kHz ~ 5MHz	56	46
5MHz ~ 30MHz	60	50

Notes: 1. * Decreasing linearly with logarithm of frequency.

2. The lower limit shall apply at the transition frequencies.

3.4. Configuration of EUT on Test

The following equipment are installed on Power Line Conducted Emission Test to meet the commission requirement and operating regulations in a manner which tends to maximize its emission characteristics in a normal application.

3.4.1. Tablet PC (EUT)

Model Number : T10COT
Serial Number : N/A

3.4.2. Support Equipment: As Tested Supporting System Details, in Section 2.4.

3.5. Operating Condition of EUT

EUT Exercise Program and Condition	
Operating System	Windows 7
Test Program	Running Brunin Test V5.3
Graphic Controller	Display scrolling "H" pattern with respective resolution
IDE and/or SATA Controller	Read/Write operation to hard disk Read/Write operation to DVD Writable/CD-RW Drive
Audio Controller	Play 1kHz audio signal
LAN & Modem Controller	Data transfer to client
USB Ports	Read/Write operation to USB Mouse/ USB Keyboard
Card Reader	Read/Write operation to PC card

3.6. Test Procedure

The EUT was placed on a non-metallic table, 80cm above the ground plane. The EUT Power connected to the power mains through a line impedance stabilization network (L.I.S.N. 1#). The other peripheral devices power cord connected to the power mains through a line impedance stabilization network (L.I.S.N.#3). This provides a 50 ohm coupling impedance for the EUT (Please refer the block diagram of the test setup and photographs). The AC line are checked to find out the maximum conducted emission. In order to find the maximum emission levels, the relative positions of equipment and all of the interface cables shall be changed according to ANSI C63.10: 2009 on Conducted Emission Test.

The bandwidth of test receiver (R & S ESHS10) is set at 10kHz.

The frequency range from 150kHz to 30MHz is checked.

3.7. Power Line Conducted Emission Test Results

PASS. (All emissions not reported below are too low against the prescribed limits.)

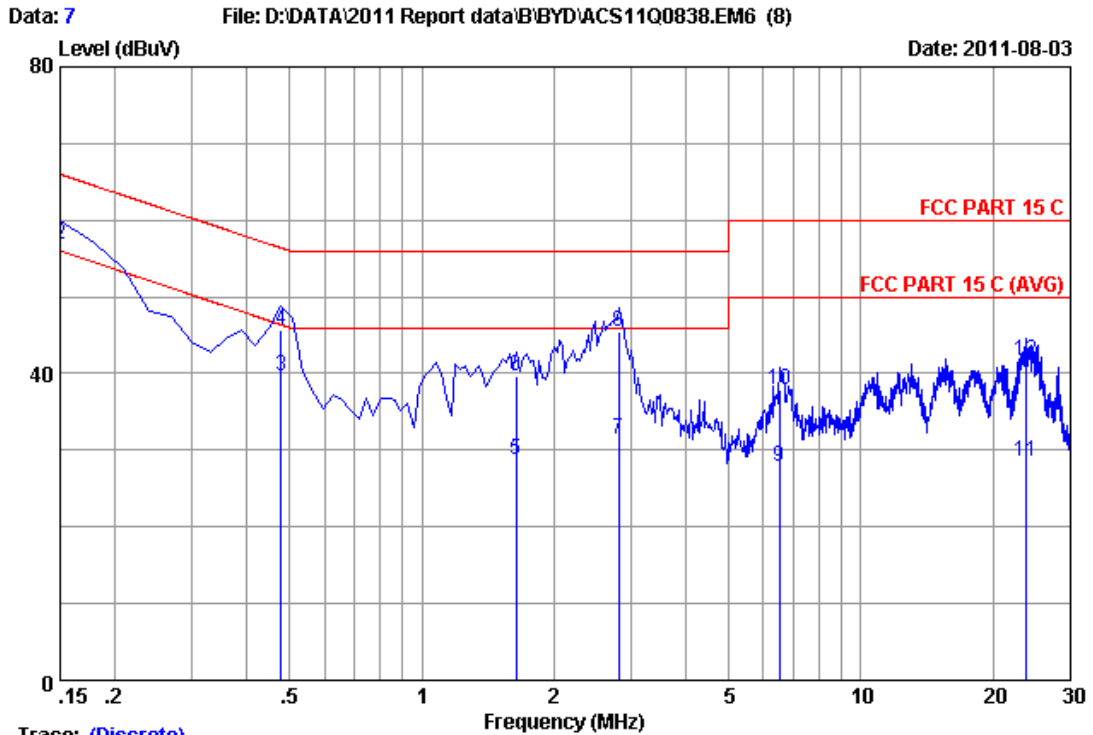

Trace: (Discrete)

Site no : 1#conduction Data No : 7
 Dis./Ant. : ** 2011 ESH2-25 LINE
 Limit : FCC PART 15 C
 Env./Ins. : 29.5°C/55% Engineer : Leo_Li
 EUT : Tablet PC
 Power Rating : DC 19V From Adapter Input AC 120V/60Hz
 Test Mode : Tx Mode (Bluetooth)
 M/N: T10COT

No	Freq (MHz)	LISN Factor (dB)	Cable Loss (dB)	Reading (dBuV)	Emission Level (dBuV)	Limits (dBuV)	Margin (dB)	Remark
1	0.15000	0.17	9.98	27.71	37.86	56.00	18.14	Average
2	0.15000	0.17	9.98	46.71	56.86	66.00	9.14	QP
3	0.47835	0.19	9.98	29.59	39.76	46.37	6.61	Average
4	0.47835	0.19	9.98	35.59	45.76	56.37	10.61	QP
5	1.643	0.28	9.97	18.43	28.68	46.00	17.32	Average
6	1.643	0.28	9.97	29.43	39.68	56.00	16.32	QP
7	2.807	0.33	9.95	21.24	31.52	46.00	14.48	Average
8	2.807	0.33	9.95	35.24	45.52	56.00	10.48	QP
9	6.508	0.45	9.92	17.42	27.79	50.00	22.21	Average
10	6.508	0.45	9.92	27.42	37.79	60.00	22.21	QP
11	23.851	1.18	10.06	17.35	28.59	50.00	21.41	Average
12	23.851	1.18	10.06	30.35	41.59	60.00	18.41	QP

Remarks: 1. Emission Level=LISN Factor+Cable Loss(Include 10dB pulse limit)+Reading.
 2. If the average limit is met when using a quasi-peak detector, the EUT shall be deemed to meet both limits and measurement with average detector is unnecessary.

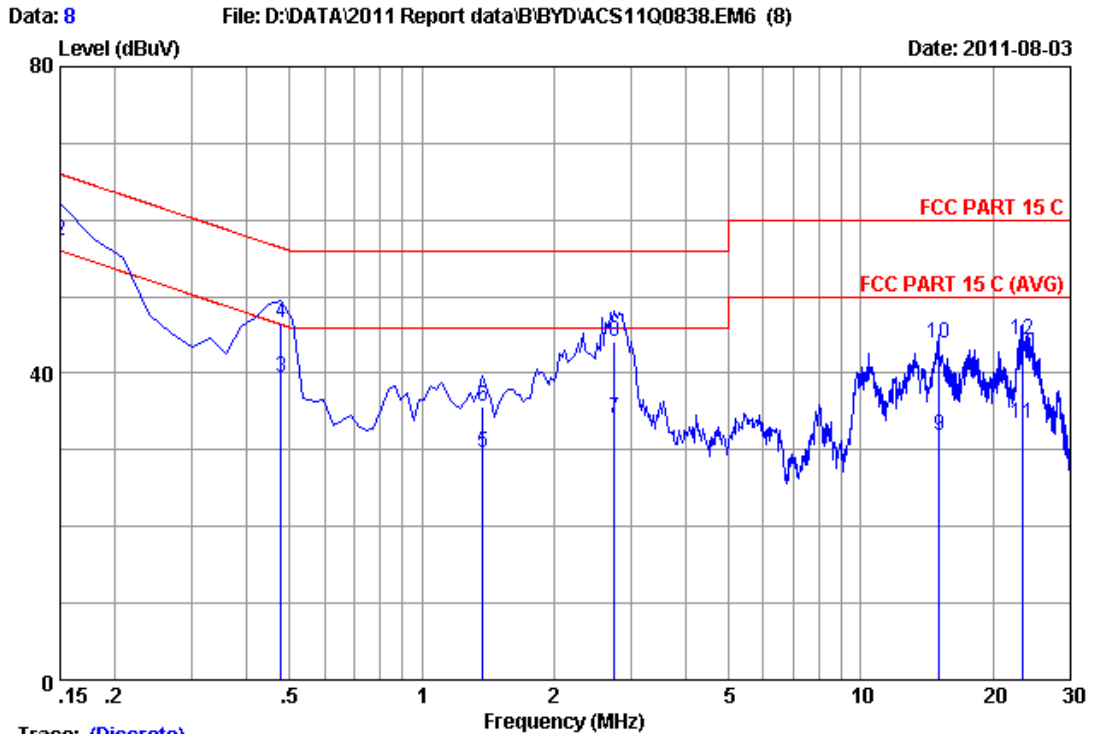

Trace: (Discrete)
 Site no :1#conduction Data No :8
 Dis./Ant. **: 2011 ESH2-Z5 NEUTRAL
 Limit :FCC PART 15 C
 Env./Ins. :29.5*C/55% Engineer :Leo_Li
 EUT :Tablet PC
 Power Rating :DC 19V From Adapter Input AC 120V/60Hz
 Test Mode :Tx Mode (Bluetooth)
 M/N:T10COT

No	Freq (MHz)	LISN Factor (dB)	Cable Loss (dB)	Reading (dBuV)	Emission Level (dBuV)	Limits (dBuV)	Margin (dB)	Remark
1	0.15000	0.21	9.98	37.00	47.19	56.00	8.81	Average
2	0.15000	0.21	9.98	47.00	57.19	66.00	8.81	QP
3	0.47835	0.22	9.98	29.34	39.54	46.37	6.83	Average
4	0.47835	0.22	9.98	36.34	46.54	56.37	9.83	QP
5	1.374	0.25	9.97	19.37	29.59	46.00	16.41	Average
6	1.374	0.25	9.97	25.37	35.59	56.00	20.41	QP
7	2.747	0.29	9.95	23.83	34.07	46.00	11.93	Average
8	2.747	0.29	9.95	33.83	44.07	56.00	11.93	QP
9	15.075	0.60	9.92	21.44	31.96	50.00	18.04	Average
10	15.075	0.60	9.92	33.44	43.96	60.00	16.04	QP
11	23.254	0.85	10.06	22.44	33.35	50.00	16.65	Average
12	23.254	0.85	10.06	33.44	44.35	60.00	15.65	QP

Remarks: 1.Emission Level=LISN Factor+Cable Loss(Include 10dB pulse limit)+Reading.
 2.If the average limit is met when using a quasi-peak detector, the EUT shall be deemed to meet both limits and measurement with average detector is unnecessary.

4. RADIATED EMISSION TEST

4.1. Test Equipment

Frequency rang: 30~1000MHz

Item	Equipment	Manufacturer	Model No.	Serial No.	Last Cal.	Cal. Interval
1	3#Chamber	AUDIX	N/A	N/A	Dec.06,10	1 Year
2	EMI Spectrum	Agilent	E4407B	MY41440292	May.08, 11	1 Year
3	Test Receiver	Rohde & Schwarz	ESVS10	834468/011	May.08, 11	1 Year
4	Amplifier	HP	8447D	2648A04738	May.08, 11	1 Year
5	Bilog Antenna	Schaffner	CBL6111C	2598	Oct.26, 10	1 Year
6	RF Cable	MIYAZAKI	8D-FB	3# Chamber No.1	May.08, 11	1 Year
7	Coaxial Switch	Anritsu	MP59B	M73989	May.08, 11	1 Year

Frequency rang: above 1000MHz

Item	Equipment	Manufacturer	Model No.	Serial No.	Last Cal.	Cal. Interval
1	Spectrum Analyzer	Agilent	E4407B	MY41440292	May 08, 11	1 Year
2	Horn Antenna	EMCO	3115	9607-4877	May 08, 11	1.5 Year
3	Amplifier	Agilent	8449B	3008A00863	May 08, 11	1 Year
4	RF Cable	Hubersuhner	SUCOFLEX102	28622/2	May 08, 11	1 Year
5	RF Cable	Hubersuhner	SUCOFLEX102	29091/2	May 08, 11	1 Year

4.2. Block Diagram of Test Setup

For frequency range 30MHz-1000MHz

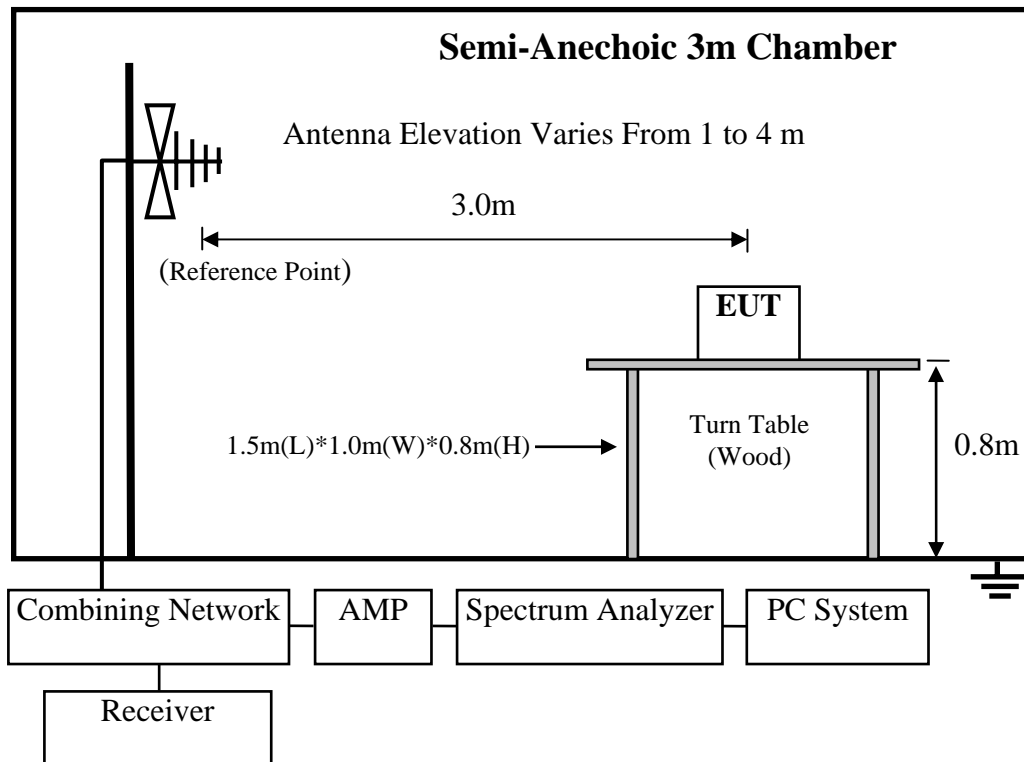

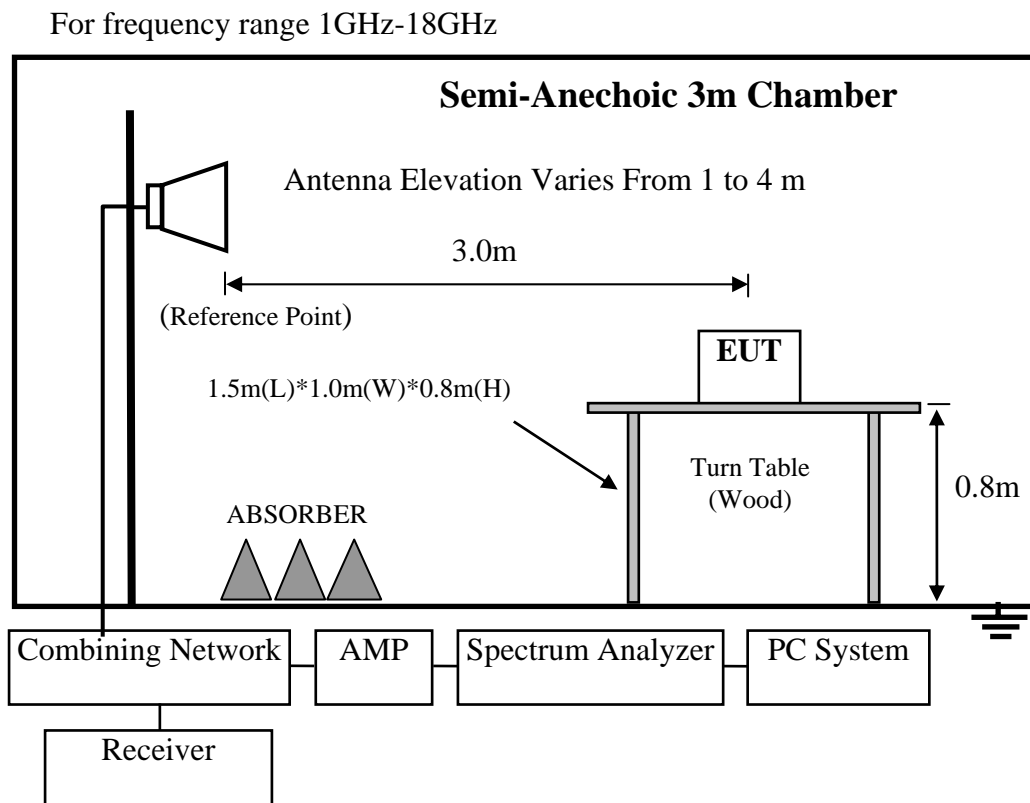

4.3. Radiated Emission Limit Standard: FCC 15.209

FREQUENCY MHz	DISTANCE Meters	FIELD STRENGTHS LIMIT	
		$\mu\text{V}/\text{m}$	$\text{dB}(\mu\text{V})/\text{m}$
30 ~ 88	3	100	40.0
88 ~ 216	3	150	43.5
216 ~ 960	3	200	46.0
960 ~ 1000	3	500	54.0
Above 1000MHz	3	74.0 $\text{dB}(\mu\text{V})/\text{m}$ (Peak) 54.0 $\text{dB}(\mu\text{V})/\text{m}$ (Average)	

- Remark :
- (1) Emission level $\text{dB}\mu\text{V} = 20 \log$ Emission level $\mu\text{V}/\text{m}$
 - (2) The smaller limit shall apply at the cross point between two frequency bands.
 - (3) Distance is the distance in meters between the measuring instrument, antenna and the closest point of any part of the device or system.
 - (4) The emission limits shown in the above table are based on measurements employing a CISPR quasi-peak detector except for the frequency bands 9-90 kHz, 110-490 kHz and above 1000 MHz. Radiated emission limits in these three bands are based on measurements employing an average detector.

4.4. EUT Configuration on Test

4.4.1. The configurations of EUT are listed in Section 3.4.

4.5. Operating Condition of EUT

4.5.1. Same as Conducted Emission test that is listed in Section 3.5. except the test set up replaced by Section 4.2.

4.6. Test Procedure

The EUT and its simulators are placed on a turn table, which is 0.8 meter high above ground. The turn table can rotate 360 degrees to determine the position of the maximum emission level. The EUT is set 3 meters away from the receiving antenna, which is mounted on an antenna tower. The antenna can be moved up and down between 1 meter and 4 meters to find out the maximum emission level. Broadband antenna (calibrated bilog antenna) is used as receiving antenna. Both horizontal and vertical polarization of the antenna is set on Test. In order to find the maximum emission levels, all of the interface cables must be manipulated according to ANSI C63.10-2009 on radiated emission Test.

This test was performed with EUT in X, Y, Z position, and the worse case was found when EUT in X position as the test photo indicated.

The bandwidth of the EMI test receiver (R&S ESVS10) is set at 120kHz for frequency range from 30MHz to 1000 MHz.

The bandwidth of the Spectrum's RBW is set at 1MHz and VBW is set at 3MHz for peak emissions measurement above 1GHz

This device is pulse modulated, a duty cycle factor was used to calculate average level based measured peak level.

The frequency range from 30MHz to 10th harmonic (25GHz) are checked. and no any emissions were found from 18GHz to 25 GHz, So the radiated emissions from 18GHz to 25GHz were not record.

4.7. Radiated Emission Test Results

PASS.

All the emissions from 30MHz to 25GHz were comply with the 15.209 Limit.

Note: The duty cycle factor for calculate average level is 8.0dB, and average limit is 20dB below peak limit, so if peak measured level comply with peak limit, the average level was deemed to comply with average limit.

Duty cycle: $0.4917\text{ms} / 1.25\text{ms} * 100\% = 39.3\%$
 Duty cycle factor = $20\log (1/\text{duty cycle}) = 8.1$

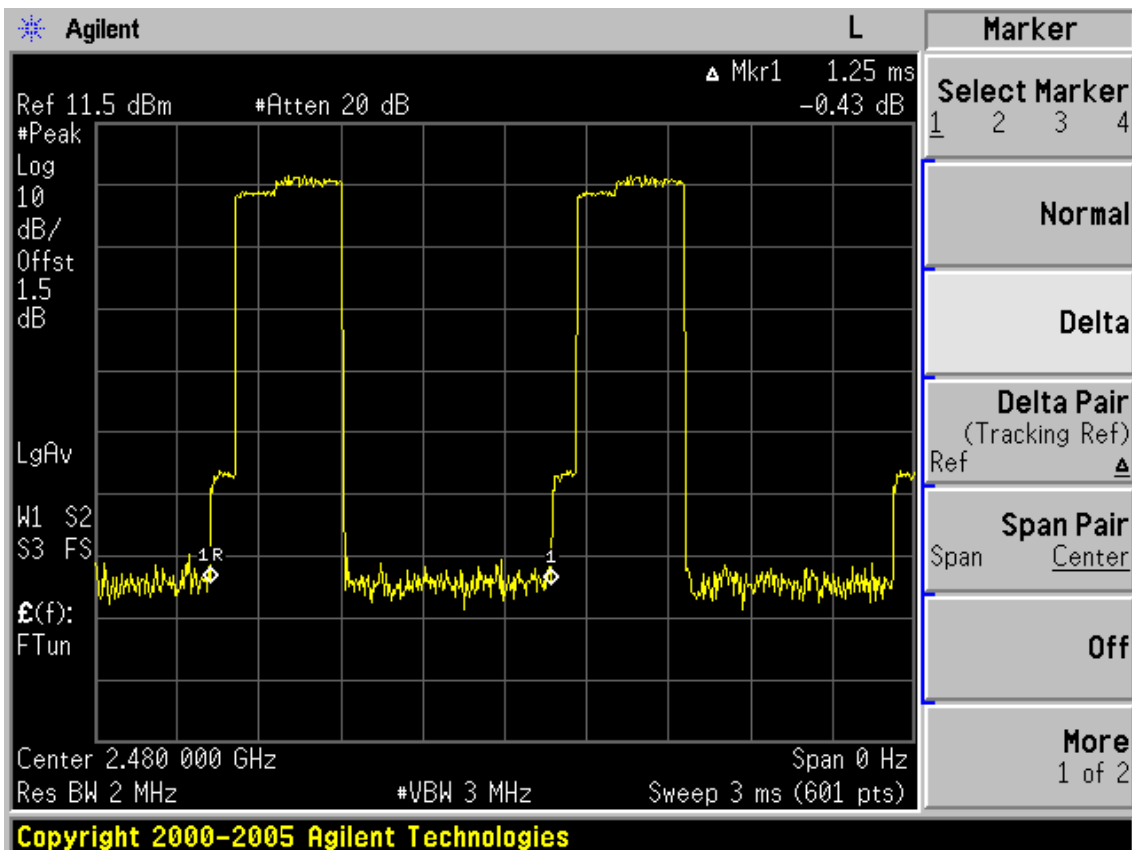
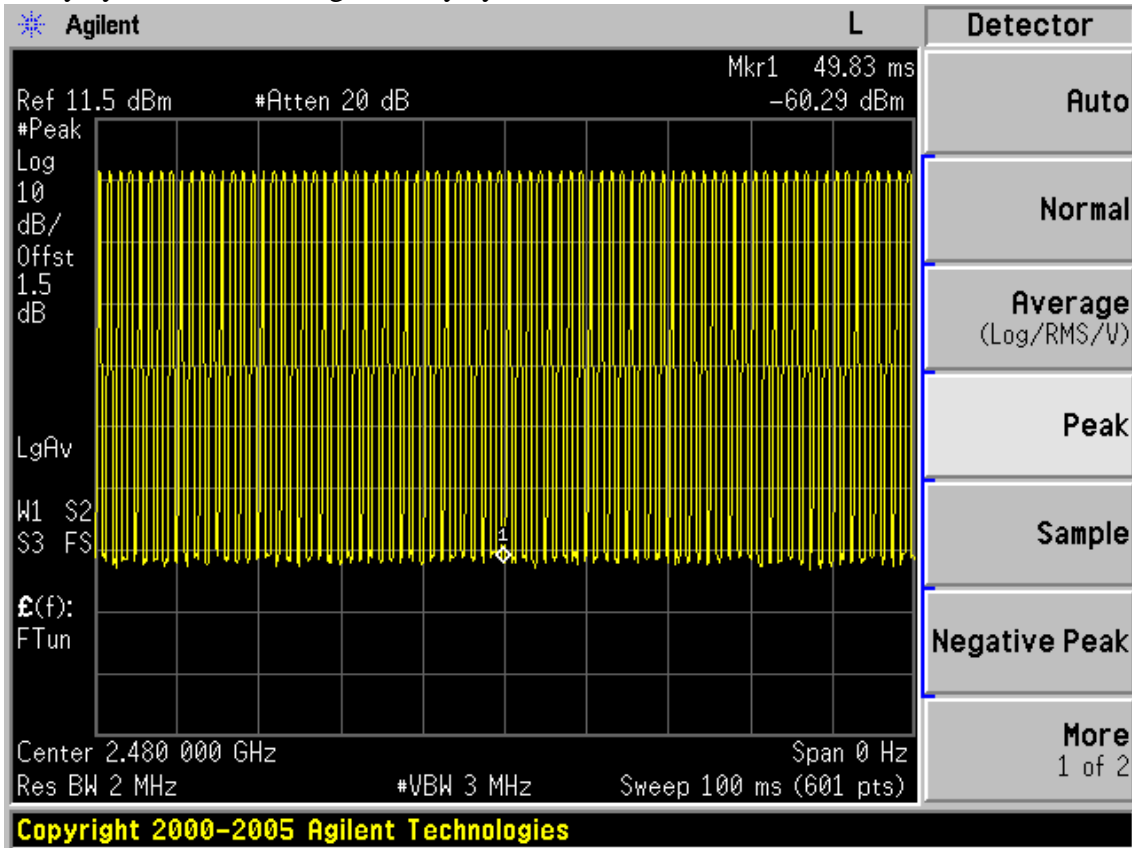

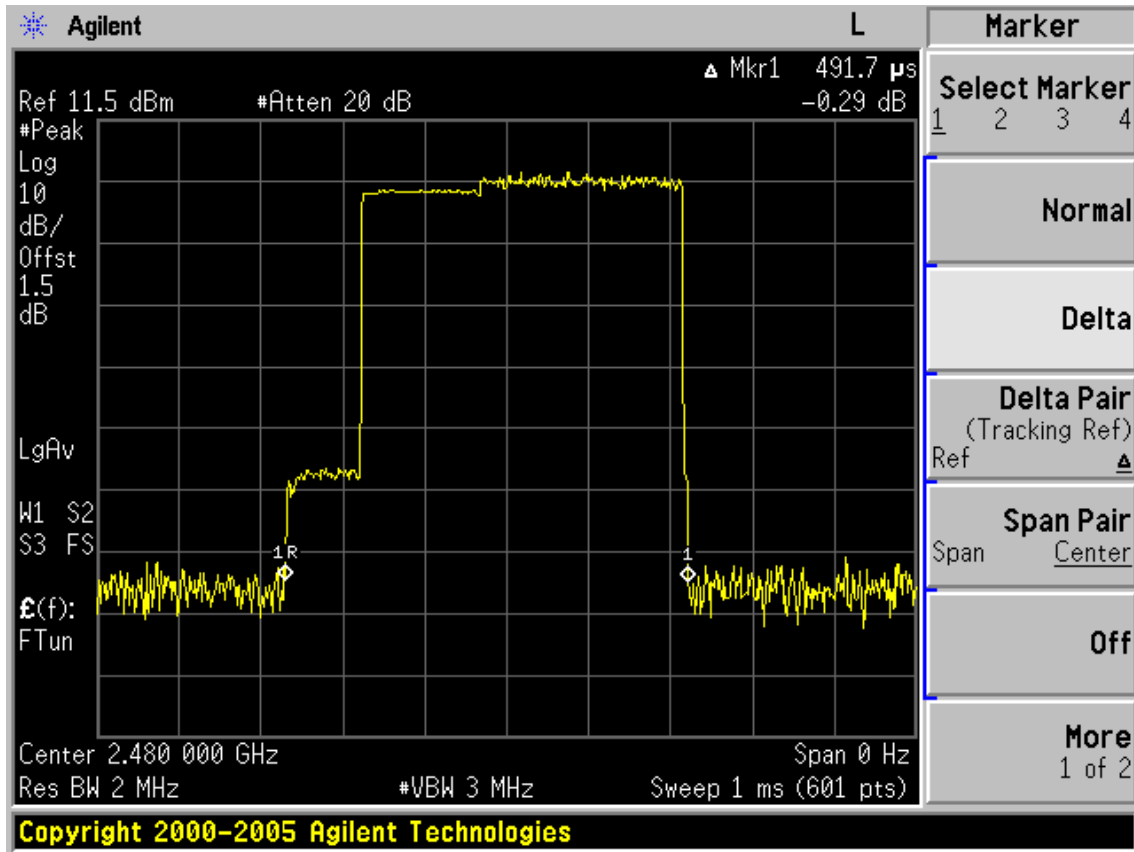

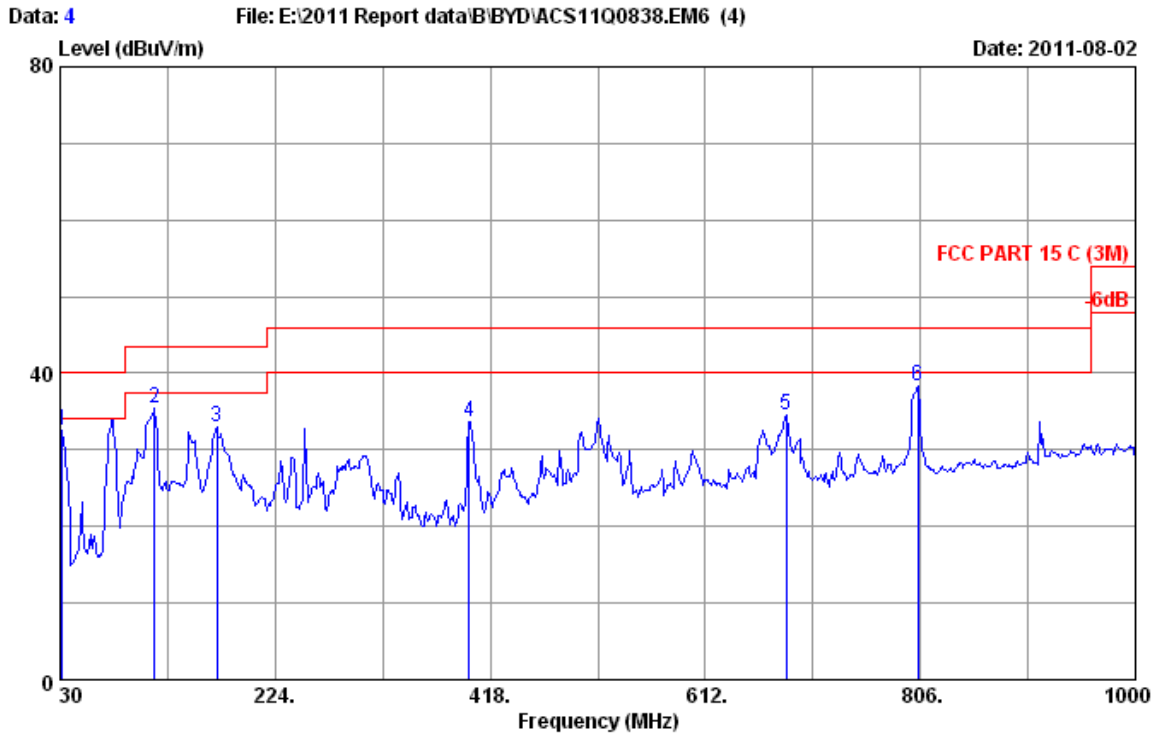

Site no. : 3m Chamber Data no. : 4
 Dis. / Ant. : 3m 2010 CBL6111C 2598 Ant. pol. : VERTICAL
 Limit : FCC PART 15 C (3M)
 Env. / Ins. : 24°C/56% Engineer : Leo-Li
 EUT : Tablet PC M/N:T10COT
 Power rating : DC 19V From Adapter input AC 120V/60Hz
 Test Mode : Tx Mode (Bluetooth)

No.	Freq. (MHz)	Ant. Factor (dB/m)	Cable Loss (dB)	Reading (dBuV)	Emission Level (dBuV/m)	Limits (dBuV/m)	Margin (dB)	Remark
1	31.940	18.88	0.61	13.11	32.60	40.00	7.40	QP
2	115.360	11.70	1.27	22.43	35.40	43.50	8.10	QP
3	171.620	10.00	1.65	21.39	33.04	43.50	10.46	QP
4	398.600	16.39	3.33	13.90	33.62	46.00	12.38	QP
5	684.750	20.75	4.93	8.92	34.60	46.00	11.40	QP
6	804.060	22.00	5.51	10.78	38.29	46.00	7.71	QP

Remarks: 1. Emission Level= Antenna Factor + Cable Loss + Reading.
 2. The emission levels that are 20dB below the official limit are not reported.

Frequency: 1GHz~18GHz

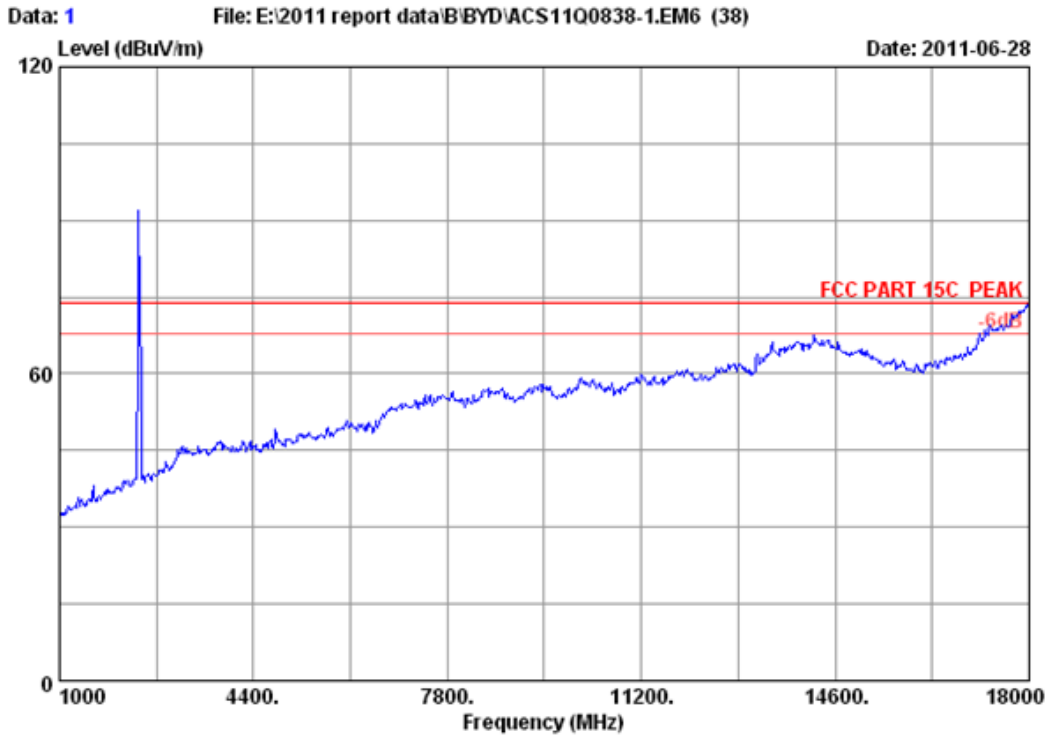

Site no.	: 3m Chamber	Data no. :	1
Dis. / Ant.	: 3m 2011 3115 4580	Ant. pol. :	HORIZONTAL
Limit	: FCC PART 15C PEAK		
Env. / Ins.	: 23°C/54%	Engineer :	Leo-Li
EUT	: Tablet PC		
Power	: DC 19V From Adapter input AC 120V/60Hz		
Test mode	: GFSK 2402MHz Tx		
M/N	: T10COT		

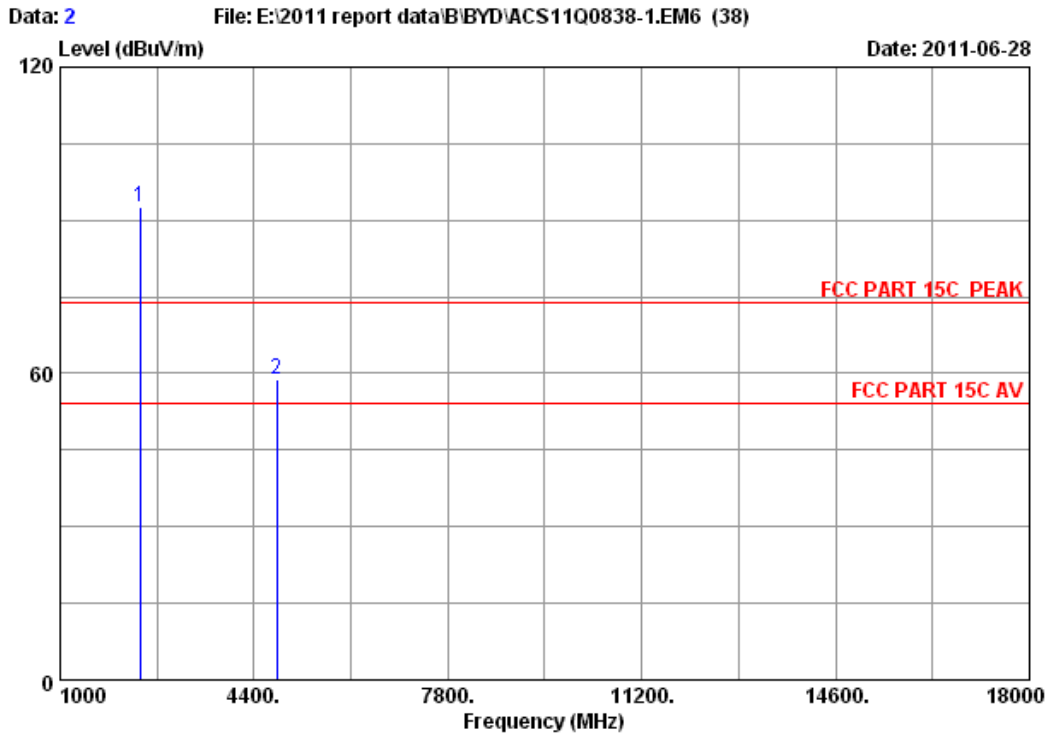

Site no. : 3m Chamber Data no. : 2
 Dis. / Ant. : 3m 2011 3115 4580 Ant. pol. : HORIZONTAL
 Limit : FCC PART 15C PEAK
 Env. / Ins. : 23°C/54% Engineer : Leo-Li
 EUT : Tablet PC
 Power supply : DC 19V From Adapter input AC 120V/60Hz
 Test mode : GFSK 2402MHz Tx
 M/N : T10COT

	Freq. (MHz)	Ant. Factor (dB/m)	Cable loss (dB)	Amp. Factor (dB)	Reading (dBuV)	Emission Level (dBuV/m)	Limits (dBuV/m)	Margin (dB)	Remark
1	2402.000	27.96	6.75	34.44	92.37	92.64	74.00	-18.64	Peak
2	4804.000	32.86	9.55	34.60	51.02	58.83	74.00	15.17	Peak

Remarks:

- Emission Level= Antenna Factor + Cable Loss -Amp Factor + Reading.
- The emission levels that are 20dB below the official limit are not reported.

Frequency (MHz)	Peak level (dBuV/m)	Duty cycle factor (dB)	AV level (dBuV/m)	Limit(dBuV/m)	Conclusion
4804.000	58.83	8.1	50.73	54	Pass

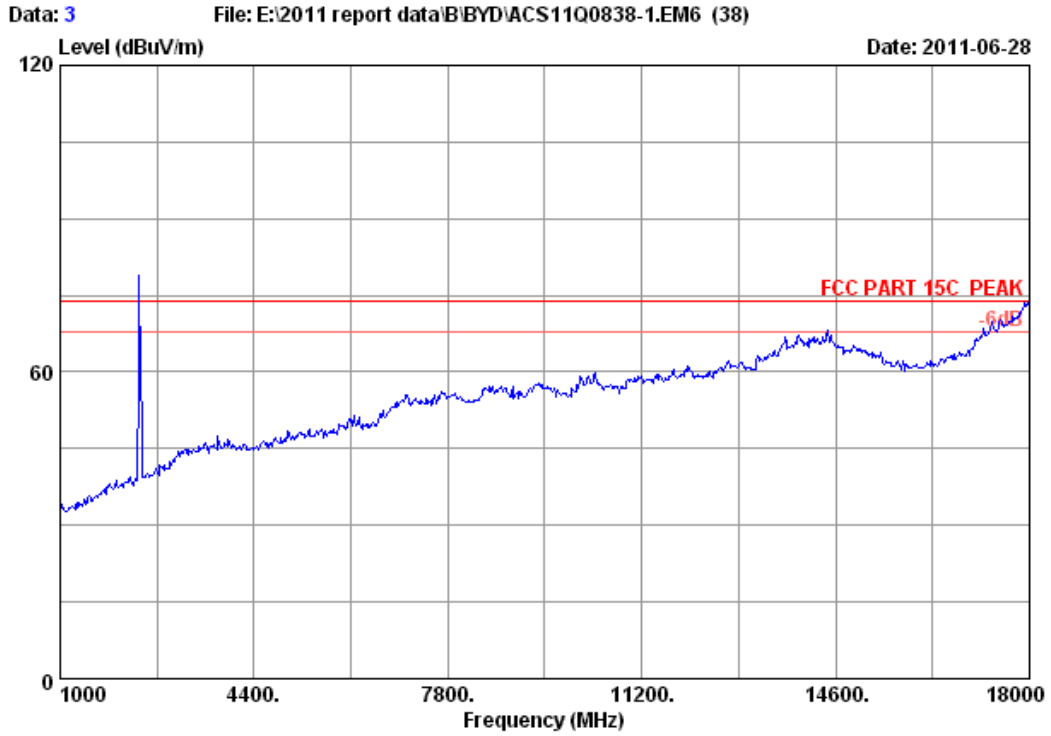

Site no. : 3m Chamber Data no. : 3
Dis. / Ant. : 3m 2011 3115 4580 Ant. pol. : VERTICAL
Limit : FCC PART 15C PEAK
Env. / Ins. : 23°C/54% Engineer : Leo-Li
EUT : Tablet PC
Power : DC 19V From Adapter input AC 120V/60Hz
Test mode : GFSK 2402MHz Tx
M/N : T10COT

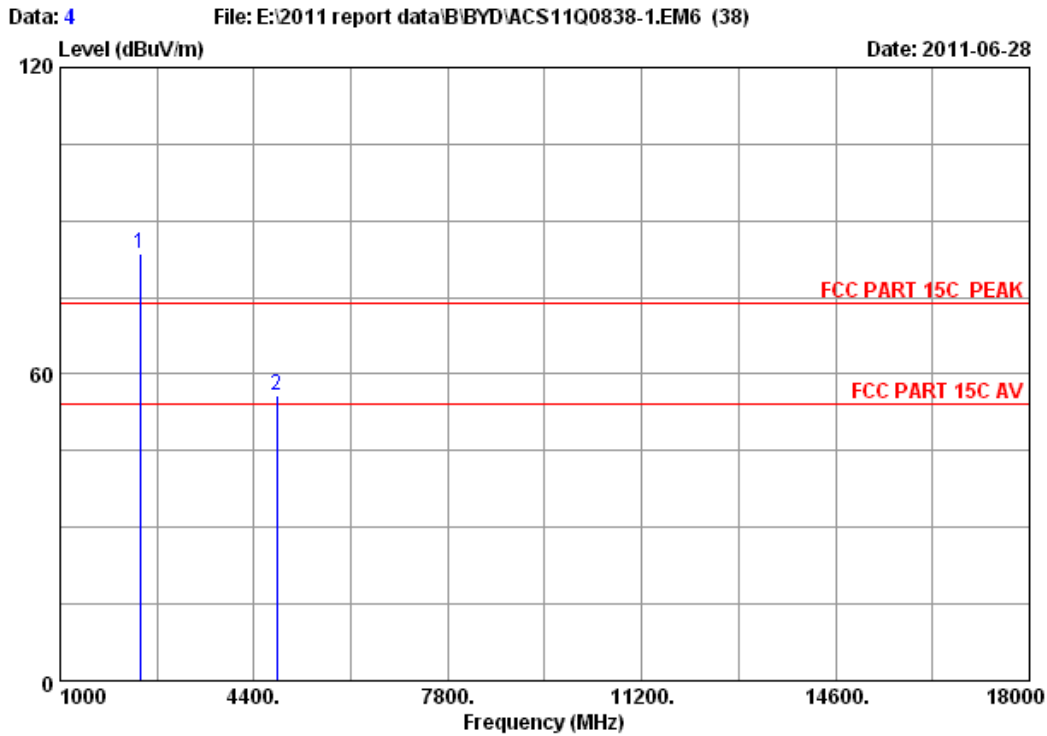

Site no. : 3m Chamber Data no. : 4
 Dis. / Ant. : 3m 2011 3115 4580 Ant. pol. : VERTICAL
 Limit : FCC PART 15C PEAK
 Env. / Ins. : 23°C/54% Engineer : Leo-Li
 EUT : Tablet PC
 Power supply : DC 19V From Adapter input AC 120V/60Hz
 Test mode : GFSK 2402MHz Tx
 M/N : T10COT

	Freq. (MHz)	Ant. Factor (dB/m)	Cable loss (dB)	Amp. Factor (dB)	Reading (dBuV)	Emission Level (dBuV/m)	Limits (dBuV/m)	Margin (dB)	Remark
1	2402.000	27.96	6.75	34.44	83.24	83.51	74.00	-9.51	Peak
2	4804.000	32.86	9.55	34.60	47.98	55.79	74.00	18.21	Peak

Remarks:

1. Emission Level= Antenna Factor + Cable Loss -Amp Factor + Reading.
2. The emission levels that are 20dB below the official limit are not reported.

Frequency (MHz)	Peak level (dBuV/m)	Duty cycle factor (dB)	AV level (dBuV/m)	Limit(dBuV/m)	Conclusion
4804.000	55.79	8.1	47.69	54	Pass

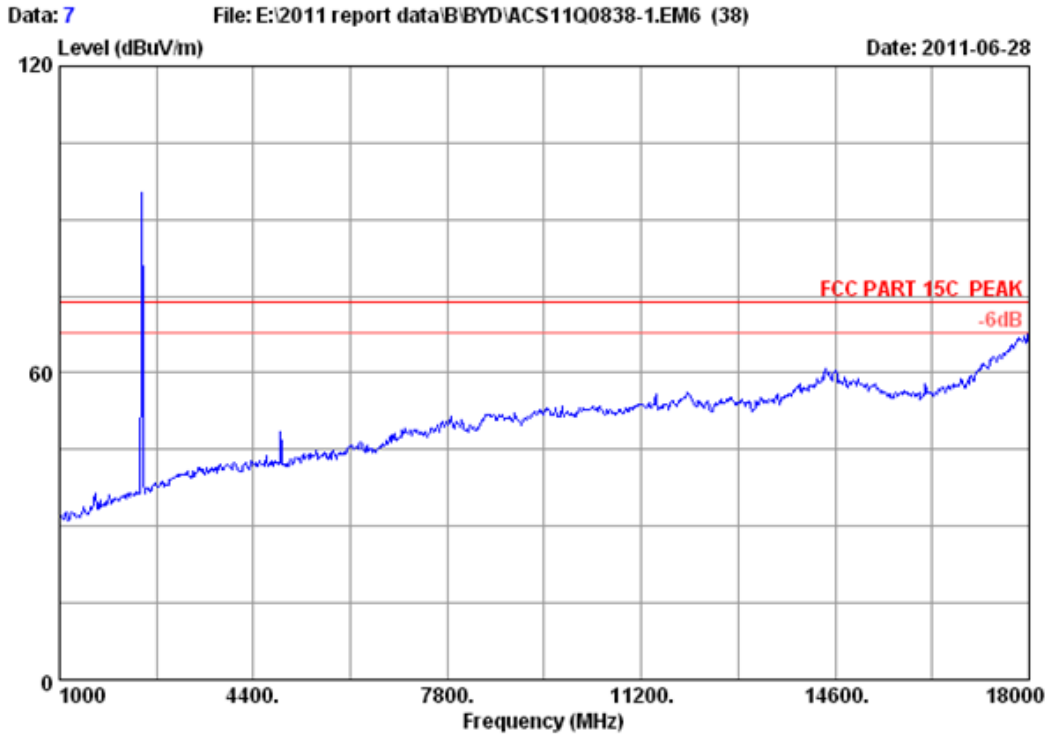

Site no. : 3m Chamber Data no. : 7
Dis. / Ant. : 3m 2011 3115 4580 Ant. pol. : HORIZONTAL
Limit : FCC PART 15C PEAK
Env. / Ins. : 23°C/54% Engineer : Leo-Li
EUT : Tablet PC
Power : DC 19V From Adapter input AC 120V/60Hz
Test mode : GFSK 2441MHz Tx
M/N : T10COT

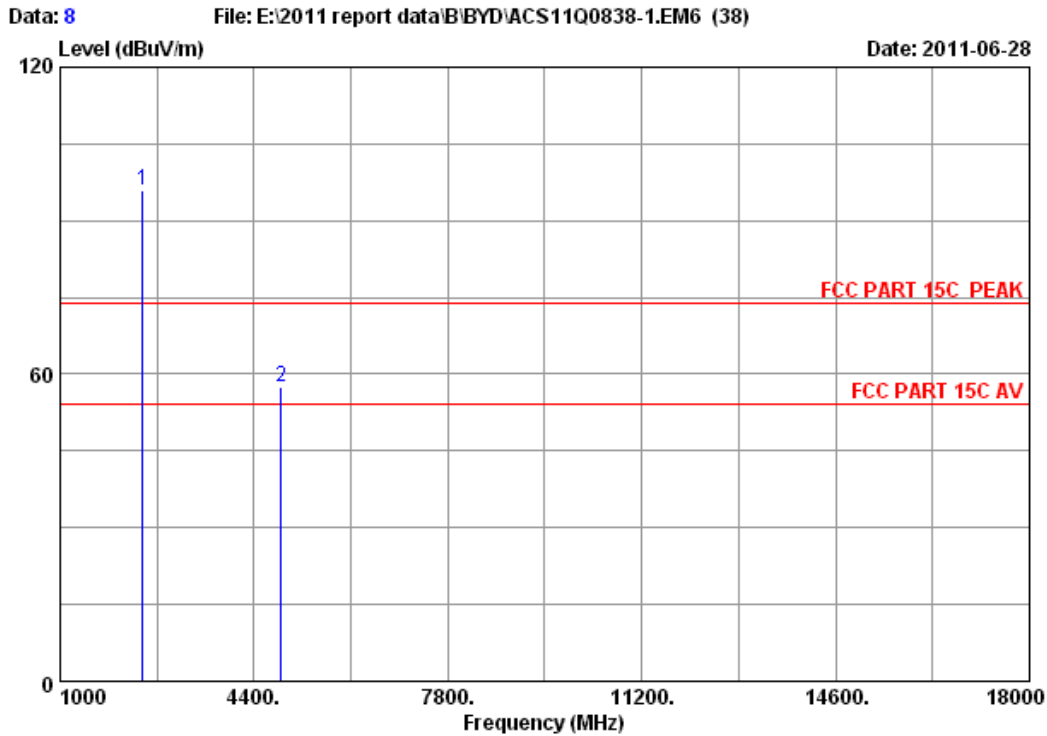

Site no. : 3m Chamber Data no. : 8
 Dis. / Ant. : 3m 2011 3115 4580 Ant. pol. : HORIZONTAL
 Limit : FCC PART 15C PEAK
 Env. / Ins. : 23°C/54% Engineer : Leo-Li
 EUT : Tablet PC
 Power supply : DC 19V From Adapter input AC 120V/60Hz
 Test mode : GFSK 2441MHz Tx
 M/N : T10COT

	Freq. (MHz)	Ant. Factor (dB/m)	Cable loss (dB)	Amp. Factor (dB)	Reading (dBuV)	Emission Level (dBuV/m)	Limits (dBuV/m)	Margin (dB)	Remark
1	2441.000	28.03	6.81	34.44	95.67	96.07	74.00	-22.07	Peak
2	4882.000	32.98	9.62	34.60	49.62	57.62	74.00	16.38	Peak

Remarks:
 1. Emission Level= Antenna Factor + Cable Loss -Amp Factor + Reading.
 2. The emission levels that are 20dB below the official limit are not reported.

Frequency (MHz)	Peak level (dBuV/m)	Duty cycle factor (dB)	AV level (dBuV/m)	Limit(dBuV/m)	Conclusion
4882.000	57.62	8.1	49.52	54	Pass

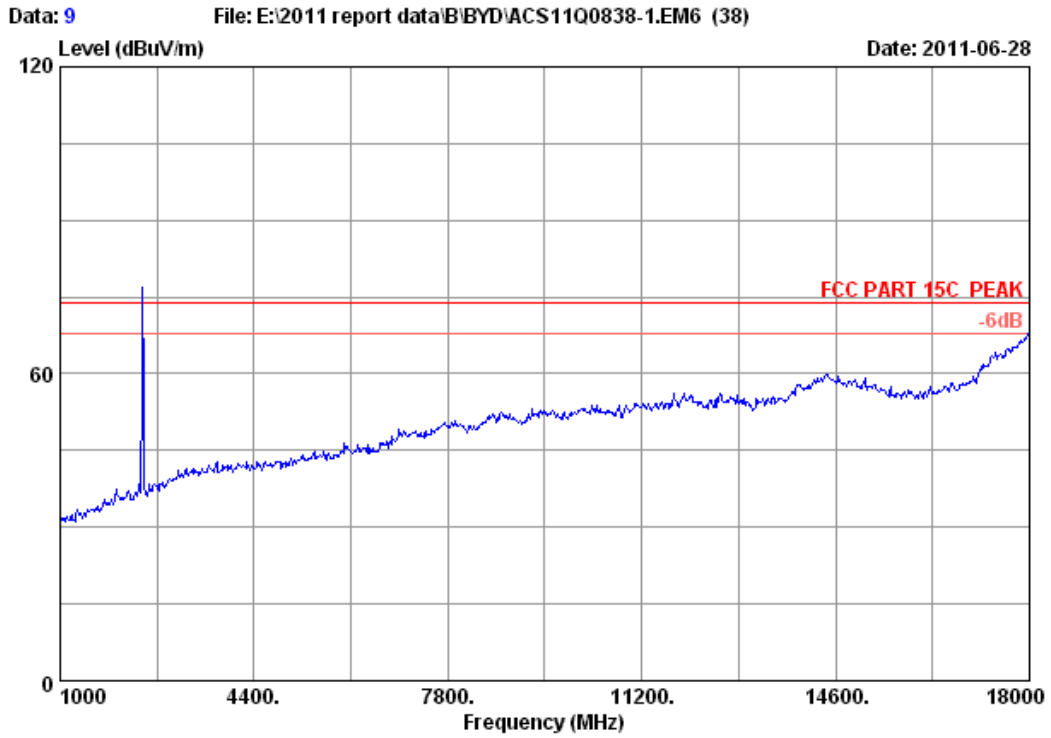

Site no. : 3m Chamber Data no. : 9
Dis. / Ant. : 3m 2011 3115 4580 Ant. pol. : VERTICAL
Limit : FCC PART 15C PEAK
Env. / Ins. : 23°C/54% Engineer : Leo-Li
EUT : Tablet PC
Power : DC 19V From Adapter input AC 120V/60Hz
Test mode : GFSK 2441MHz Tx
M/N : T10COT

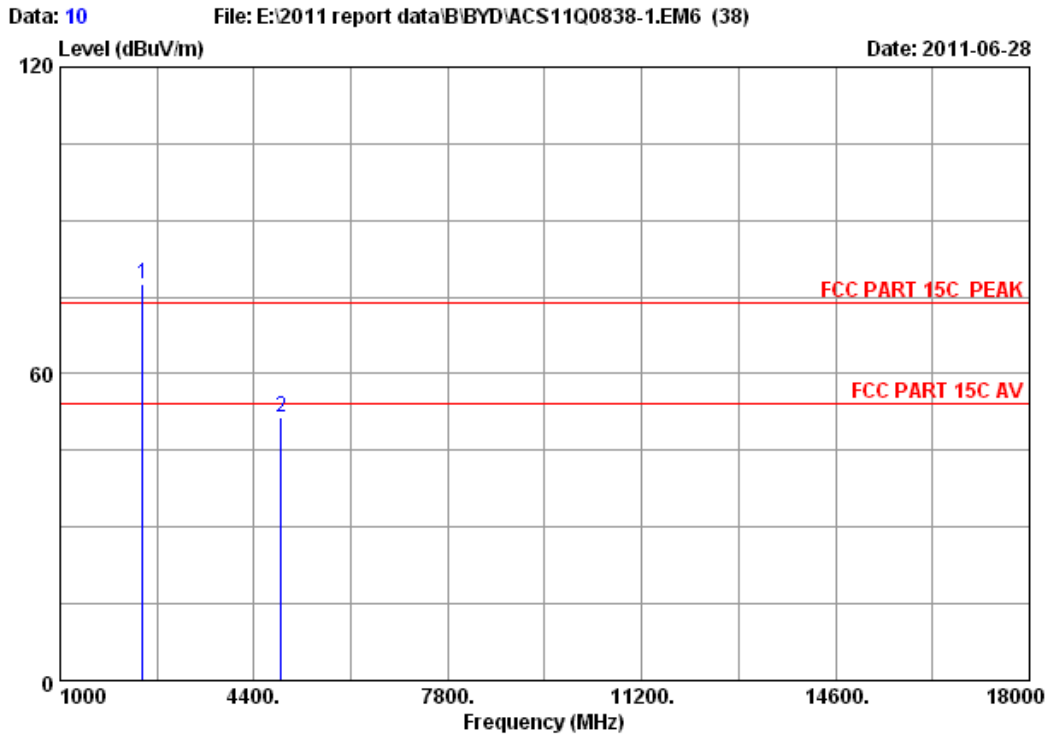

Site no. : 3m Chamber Data no. : 10
 Dis. / Ant. : 3m 2011 3115 4580 Ant. pol. : VERTICAL
 Limit : FCC PART 15C PEAK
 Env. / Ins. : 23°C/54% Engineer : Leo-Li
 EUT : Tablet PC
 Power supply : DC 19V From Adapter input AC 120V/60Hz
 Test mode : GFSK 2441MHz Tx
 M/N : T10COT

	Freq. (MHz)	Ant. Factor (dB/m)	Cable loss (dB)	Amp. Factor (dB)	Reading (dBuV)	Emission Level (dBuV/m)	Limits (dBuV/m)	Margin (dB)	Remark
1	2441.000	28.03	6.81	34.44	77.04	77.44	74.00	-3.44	Peak
2	4882.000	32.98	9.62	34.60	43.61	51.61	74.00	22.39	Peak

Remarks:
 1. Emission Level= Antenna Factor + Cable Loss -Amp Factor + Reading.
 2. The emission levels that are 20dB below the official limit are not reported.

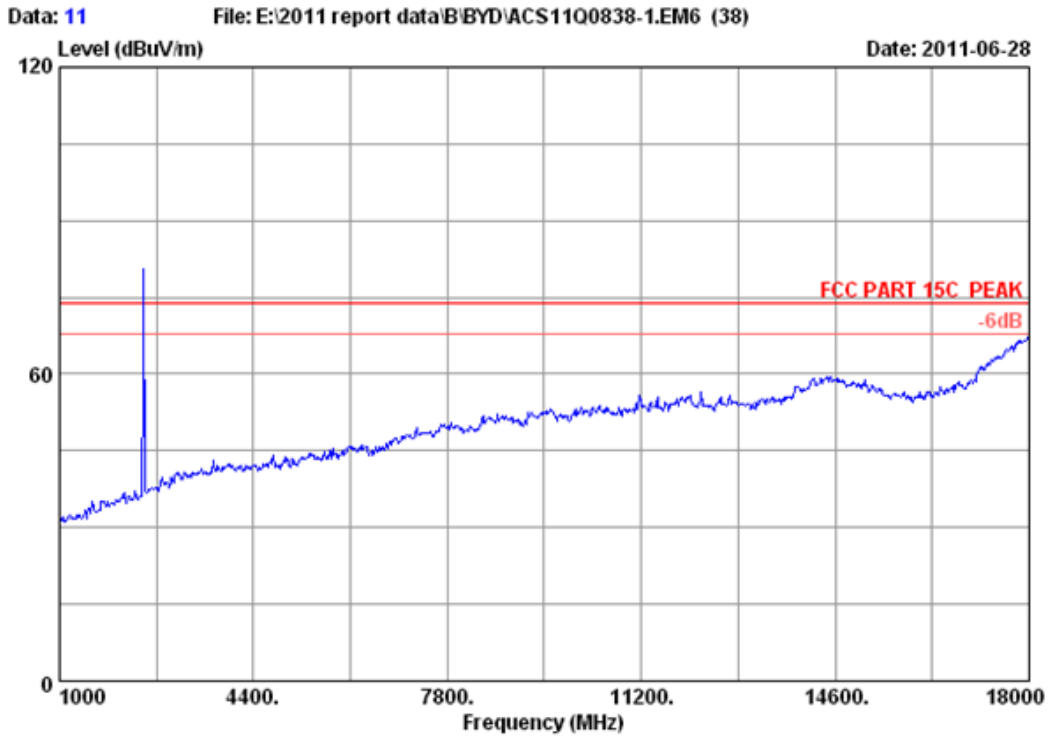

Site no.	: 3m Chamber	Data no. :	11
Dis. / Ant.	: 3m 2011 3115 4580	Ant. pol. :	VERTICAL
Limit	: FCC PART 15C PEAK		
Env. / Ins.	: 23°C/54%	Engineer :	Leo-Li
EUT	: Tablet PC		
Power	: DC 19V From Adapter input AC 120V/60Hz		
Test mode	: GFSK 2480MHz Tx		
M/N	: T10COT		

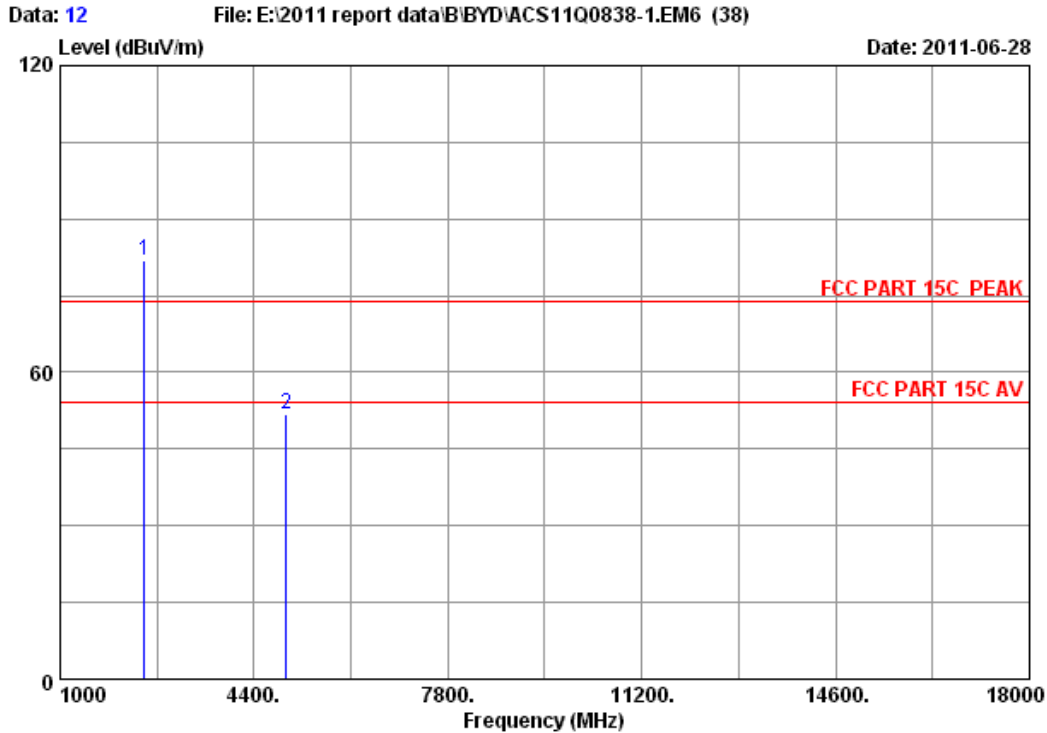

Site no. : 3m Chamber Data no. : 12
 Dis. / Ant. : 3m 2011 3115 4580 Ant. pol. : VERTICAL
 Limit : FCC PART 15C PEAK
 Env. / Ins. : 23°C/54% Engineer : Leo-Li
 EUT : Tablet PC
 Power supply : DC 19V From Adapter input AC 120V/60Hz
 Test mode : GFSK 2480MHz Tx
 M/N : T10COT

	Freq. (MHz)	Ant. Factor (dB/m)	Cable loss (dB)	Amp. Factor (dB)	Reading (dBuV)	Emission Level (dBuV/m)	Limits (dBuV/m)	Margin (dB)	Remark
1	2480.000	28.08	6.87	34.45	81.43	81.93	74.00	-7.93	Peak
2	4960.000	33.14	9.69	34.60	43.71	51.94	74.00	22.06	Peak

Remarks:
 1. Emission Level= Antenna Factor + Cable Loss -Amp Factor + Reading.
 2. The emission levels that are 20dB below the official limit are not reported.

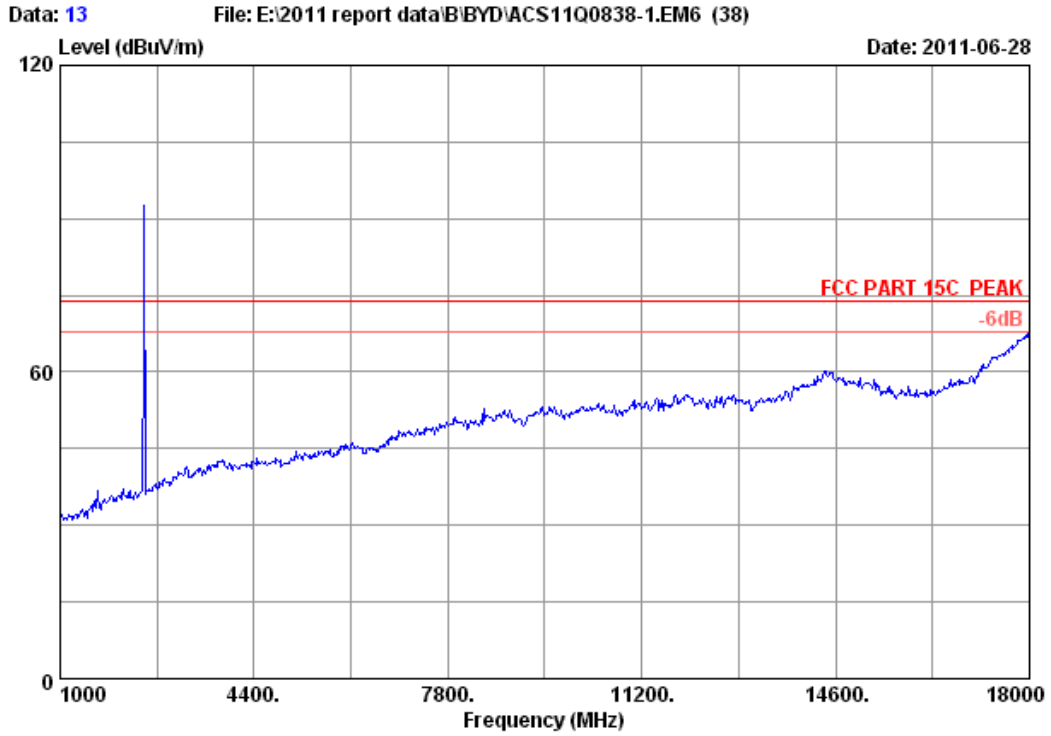

Site no. : 3m Chamber Data no. : 13
Dis. / Ant. : 3m 2011 3115 4580 Ant. pol. : HORIZONTAL
Limit : FCC PART 15C PEAK
Env. / Ins. : 23°C/54% Engineer : Leo-Li
EUT : Tablet PC
Power : DC 19V From Adapter input AC 120V/60Hz
Test mode : GFSK 2480MHz Tx
M/N : T10COT

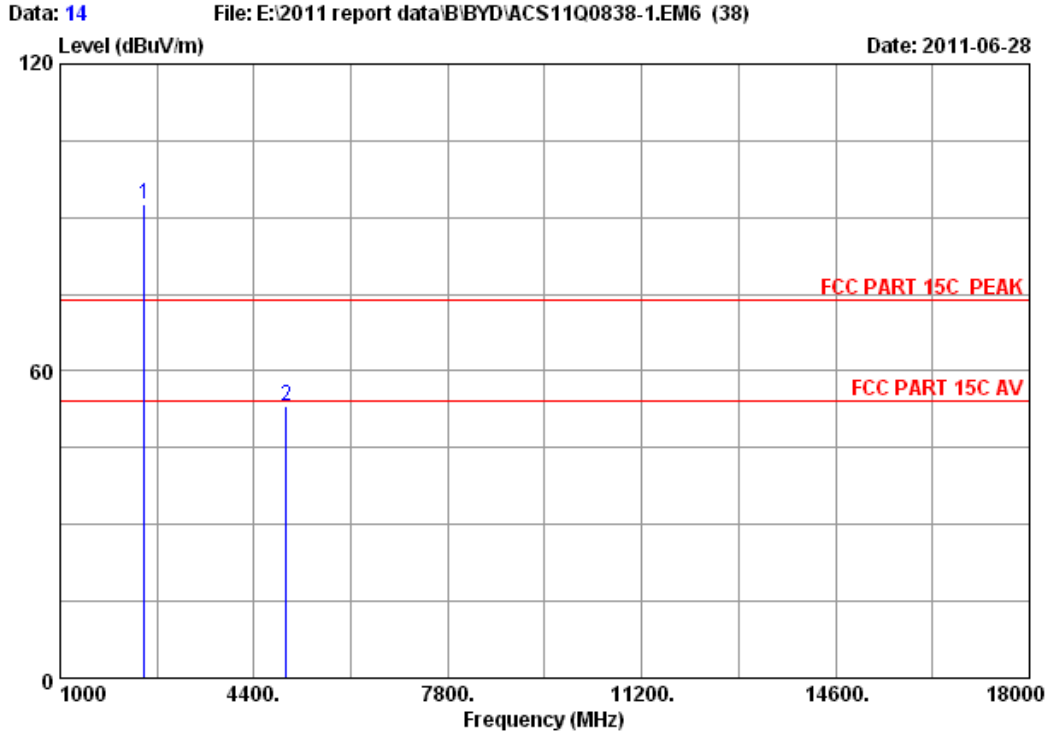

Site no. : 3m Chamber Data no. : 14
 Dis. / Ant. : 3m 2011 3115 4580 Ant. pol. : HORIZONTAL
 Limit : FCC PART 15C PEAK
 Env. / Ins. : 23°C/54% Engineer : Leo-Li
 EUT : Tablet PC
 Power supply : DC 19V From Adapter input AC 120V/60Hz
 Test mode : GFSK 2480MHz Tx
 M/N : T10COT

	Freq. (MHz)	Ant. Factor (dB/m)	Cable loss (dB)	Amp. Factor (dB)	Reading (dBuV)	Emission Level (dBuV/m)	Limits (dBuV/m)	Margin (dB)	Remark
1	2480.000	28.08	6.87	34.45	92.03	92.53	74.00	-18.53	Peak
2	4960.000	33.14	9.69	34.60	45.07	53.30	74.00	20.70	Peak

Remarks:

1. Emission Level= Antenna Factor + Cable Loss -Amp Factor + Reading.
2. The emission levels that are 20dB below the official limit are not reported.

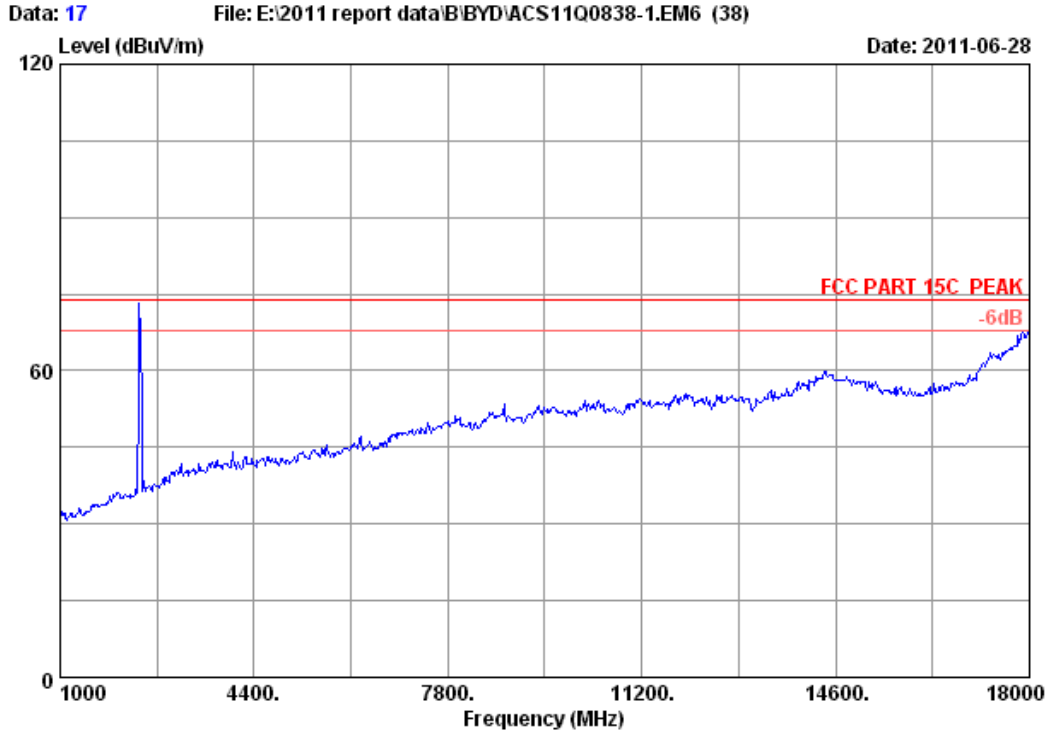

Site no.	: 3m Chamber	Data no. :	17
Dis. / Ant.	: 3m 2011 3115 4580	Ant. pol. :	VERTICAL
Limit	: FCC PART 15C PEAK		
Env. / Ins.	: 23°C/54%	Engineer :	Leo-Li
EUT	: Tablet PC		
Power	: DC 19V From Adapter input AC 120V/60Hz		
Test mode	: 8DPSK 2402MHz Tx		
M/N	: T10COT		

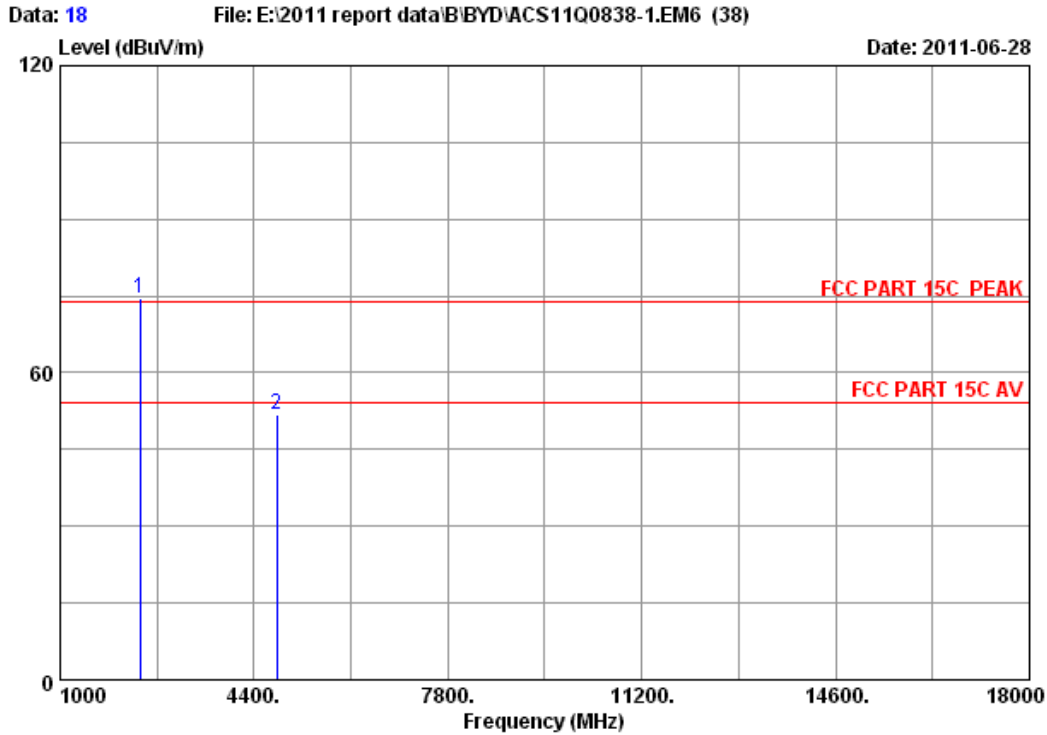

Site no. : 3m Chamber Data no. : 18
 Dis. / Ant. : 3m 2011 3115 4580 Ant. pol. : VERTICAL
 Limit : FCC PART 15C PEAK
 Env. / Ins. : 23°C/54% Engineer : Leo-Li
 EUT : Tablet PC
 Power supply : DC 19V From Adapter input AC 120V/60Hz
 Test mode : 8DPSK 2402MHz Tx
 M/N : T10COT

	Freq. (MHz)	Ant. Factor (dB/m)	Cable loss (dB)	Amp. Factor (dB)	Reading (dBuV)	Emission Level (dBuV/m)	Limits (dBuV/m)	Margin (dB)	Remark
1	2402.000	27.96	6.75	34.44	74.20	74.47	74.00	-0.47	Peak
2	4804.000	32.86	9.55	34.60	44.12	51.93	74.00	22.07	Peak

Remarks:

1. Emission Level= Antenna Factor + Cable Loss -Amp Factor + Reading.
2. The emission levels that are 20dB below the official limit are not reported.

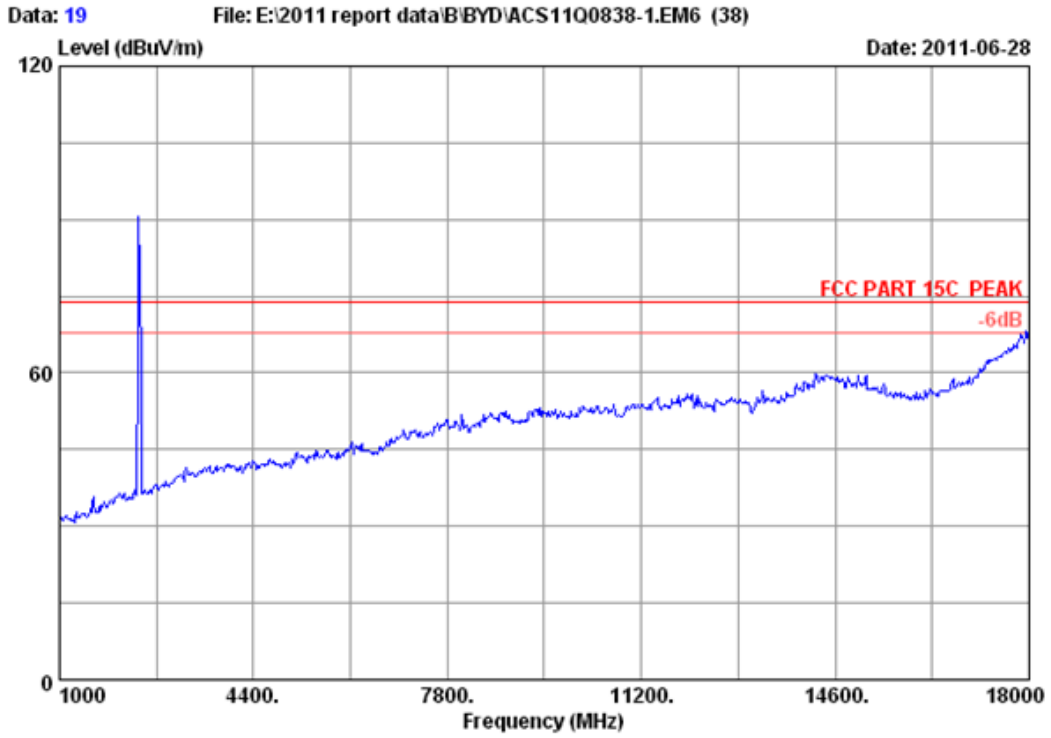

Site no. : 3m Chamber Data no. : 19
Dis. / Ant. : 3m 2011 3115 4580 Ant. pol. : HORIZONTAL
Limit : FCC PART 15C PEAK
Env. / Ins. : 23°C/54% Engineer : Leo-Li
EUT : Tablet PC
Power : DC 19V From Adapter input AC 120V/60Hz
Test mode : 8DPSK 2402MHz Tx
M/N : T10COT

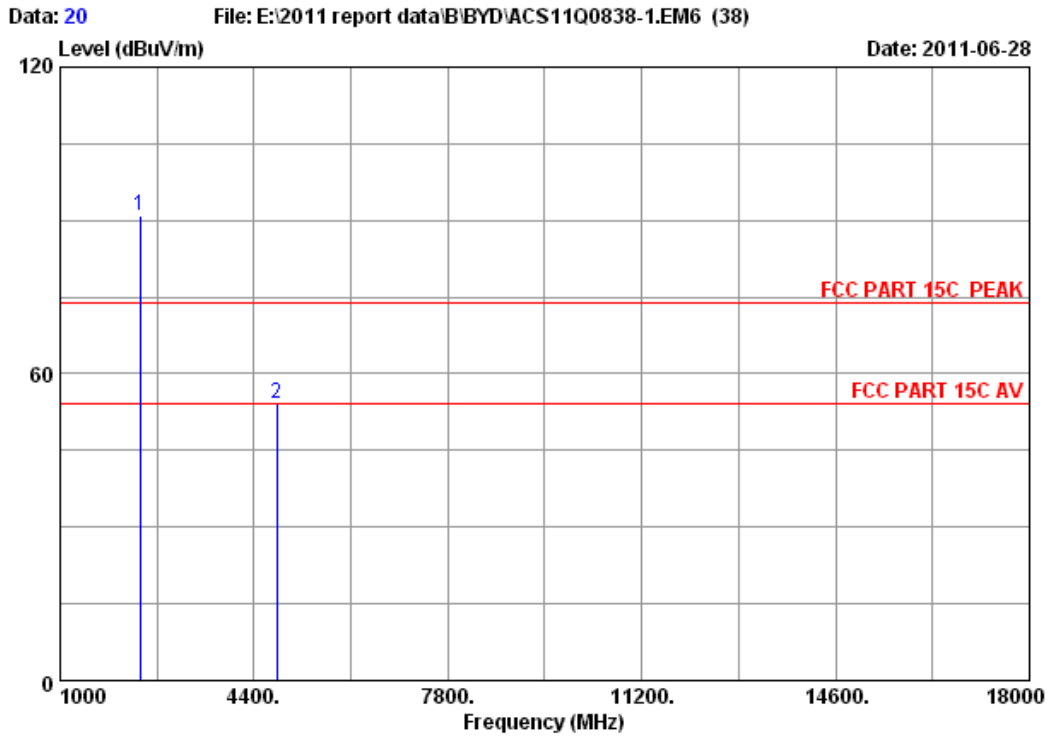

Site no. : 3m Chamber Data no. : 20
 Dis. / Ant. : 3m 2011 3115 4580 Ant. pol. : HORIZONTAL
 Limit : FCC PART 15C PEAK
 Env. / Ins. : 23°C/54% Engineer : Leo-Li
 EUT : Tablet PC
 Power supply : DC 19V From Adapter input AC 120V/60Hz
 Test mode : 8DPSK 2402MHz Tx
 M/N : T10COT

	Freq. (MHz)	Ant. Factor (dB/m)	Cable loss (dB)	Amp. Factor (dB)	Reading (dBuV)	Emission Level (dBuV/m)	Limits (dBuV/m)	Margin (dB)	Remark
1	2402.000	27.96	6.75	34.44	90.72	90.99	74.00	-16.99	Peak
2	4804.000	32.86	9.55	34.60	46.30	54.11	74.00	19.89	Peak

Remarks:

1. Emission Level= Antenna Factor + Cable Loss -Amp Factor + Reading.
2. The emission levels that are 20dB below the official limit are not reported.

Frequency (MHz)	Peak level (dBuV/m)	Duty cycle factor (dB)	AV level (dBuV/m)	Limit(dBuV/m)	Conclusion
4804.000	54.11	8.1	46.01	54	Pass

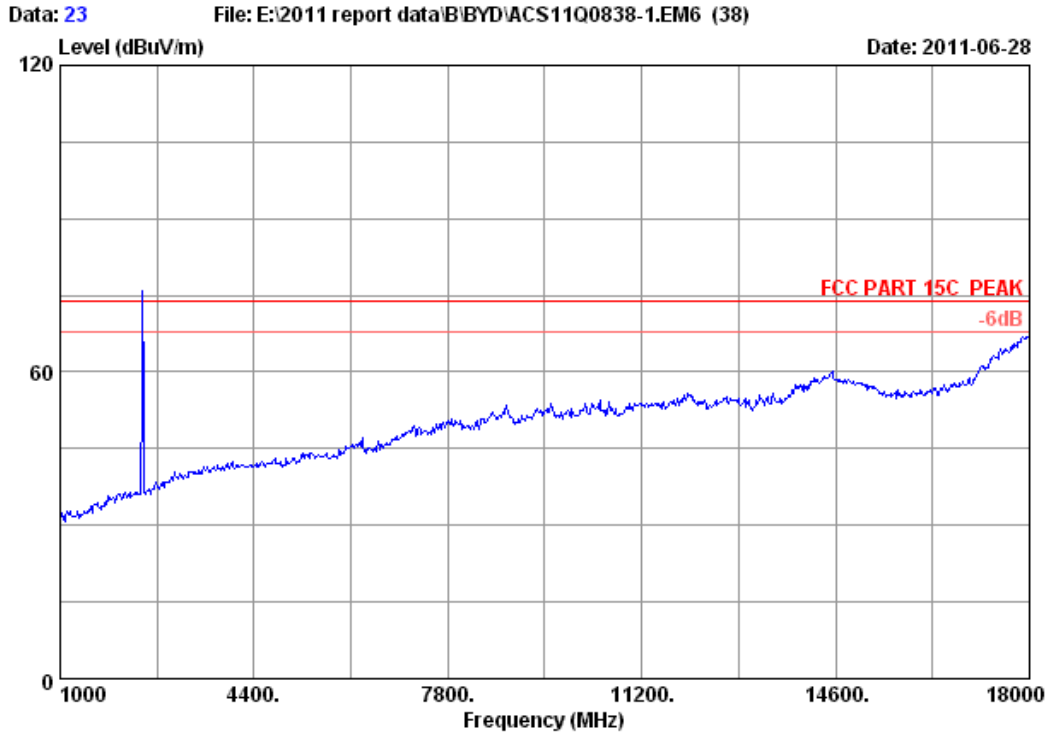

Site no. : 3m Chamber Data no. : 23
Dis. / Ant. : 3m 2011 3115 4580 Ant. pol. : VERTICAL
Limit : FCC PART 15C PEAK
Env. / Ins. : 23°C/54% Engineer : Leo-Li
EUT : Tablet PC
Power : DC 19V From Adapter input AC 120V/60Hz
Test mode : 8DPSK 2441MHz Tx
M/N : T10COT

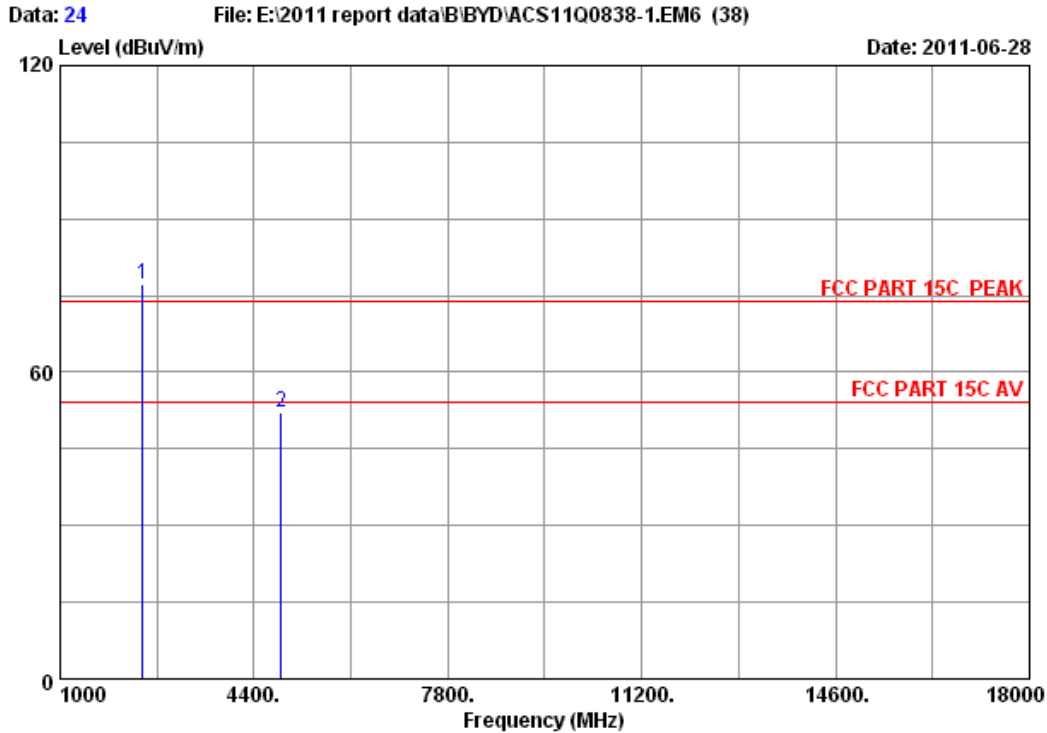

Site no. : 3m Chamber Data no. : 24
 Dis. / Ant. : 3m 2011 3115 4580 Ant. pol. : VERTICAL
 Limit : FCC PART 15C PEAK
 Env. / Ins. : 23°C/54% Engineer : Leo-Li
 EUT : Tablet PC
 Power supply : DC 19V From Adapter input AC 120V/60Hz
 Test mode : 8DPSK 2441MHz Tx
 M/N : T10COT

	Freq. (MHz)	Ant. Factor (dB/m)	Cable loss (dB)	Amp. Factor (dB)	Reading (dBuV)	Emission Level (dBuV/m)	Limits (dBuV/m)	Margin (dB)	Remark
1	2441.000	28.03	6.81	34.44	76.90	77.30	74.00	-3.30	Peak
2	4882.000	32.98	9.62	34.60	44.01	52.01	74.00	21.99	Peak

Remarks:
 1. Emission Level= Antenna Factor + Cable Loss -Amp Factor + Reading.
 2. The emission levels that are 20dB below the official limit are not reported.

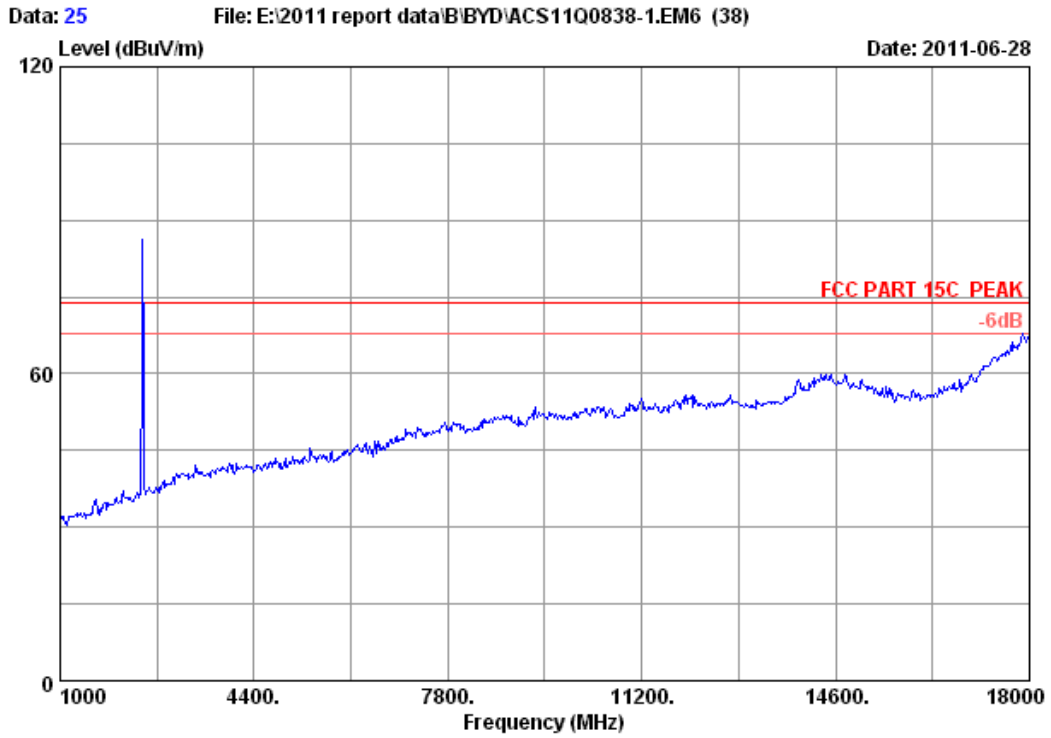

Site no.	: 3m Chamber	Data no. :	25
Dis. / Ant.	: 3m 2011 3115 4580	Ant. pol. :	HORIZONTAL
Limit	: FCC PART 15C PEAK		
Env. / Ins.	: 23°C/54%	Engineer :	Leo-Li
EUT	: Tablet PC		
Power	: DC 19V From Adapter input AC 120V/60Hz		
Test mode	: 8DPSK 2441MHz Tx		
M/N	: T10COT		

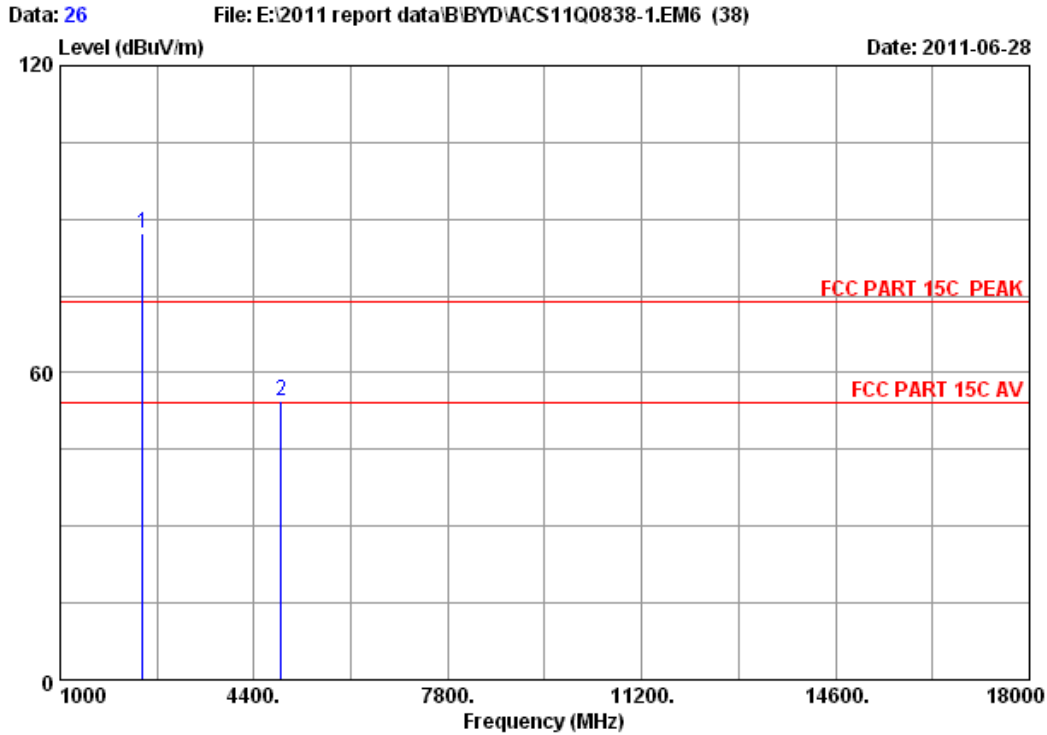

Site no. : 3m Chamber Data no. : 26
 Dis. / Ant. : 3m 2011 3115 4580 Ant. pol. : HORIZONTAL
 Limit : FCC PART 15C PEAK
 Env. / Ins. : 23*C/54% Engineer : Leo-Li
 EUT : Tablet PC
 Power supply : DC 19V From Adapter input AC 120V/60Hz
 Test mode : 8DPSK 2441MHz Tx
 M/N : T10COT

	Freq. (MHz)	Ant. Factor (dB/m)	Cable loss (dB)	Amp. Factor (dB)	Reading (dBuV)	Emission Level (dBuV/m)	Limits (dBuV/m)	Margin (dB)	Remark
1	2441.000	28.03	6.81	34.44	86.72	87.12	74.00	-13.12	Peak
2	4882.000	32.98	9.62	34.60	46.37	54.37	74.00	19.63	Peak

Remarks:

- Emission Level= Antenna Factor + Cable Loss -Amp Factor + Reading.
- The emission levels that are 20dB below the official limit are not reported.

Frequency (MHz)	Peak level (dBuV/m)	Duty cycle factor (dB)	AV level (dBuV/m)	Limit(dBuV/m)	Conclusion
4882.000	54.37	8.1	46.27	54	Pass

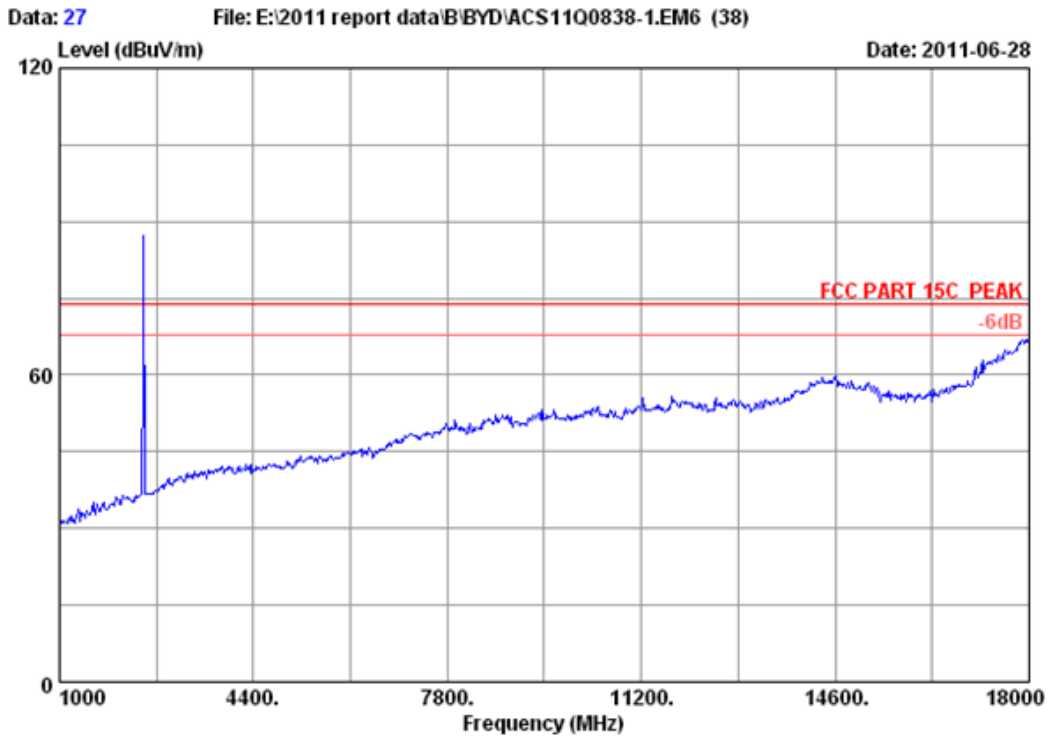

Site no.	: 3m Chamber	Data no.	: 27
Dis. / Ant.	: 3m 2011 3115 4580	Ant. pol.	: HORIZONTAL
Limit	: FCC PART 15C PEAK		
Env. / Ins.	: 23°C/54%	Engineer	: Leo-Li
EUT	: Tablet PC		
Power	: DC 19V From Adapter input AC 120V/60Hz		
Test mode	: 8DPSK 2480MHz Tx		
M/N	: T10COT		

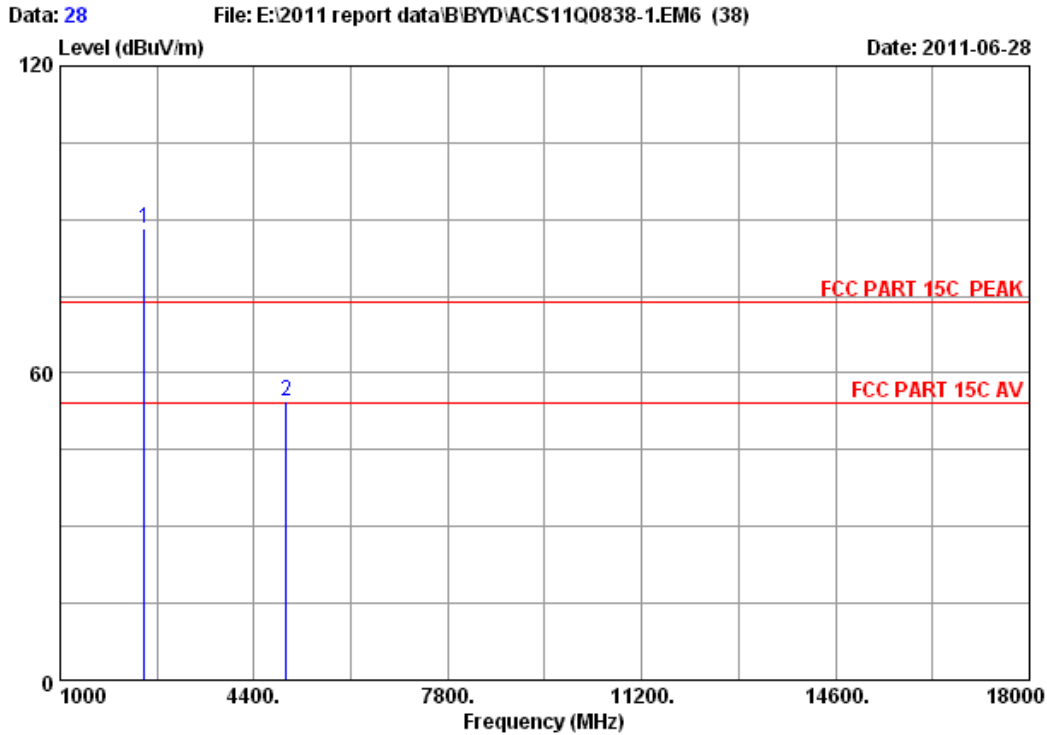

Site no. : 3m Chamber Data no. : 28
 Dis. / Ant. : 3m 2011 3115 4580 Ant. pol. : HORIZONTAL
 Limit : FCC PART 15C PEAK
 Env. / Ins. : 23°C/54% Engineer : Leo-Li
 EUT : Tablet PC
 Power supply : DC 19V From Adapter input AC 120V/60Hz
 Test mode : 8DPSK 2480MHz Tx
 M/N : T10COT

	Freq. (MHz)	Ant. Factor (dB/m)	Cable loss (dB)	Amp. Factor (dB)	Reading (dBuV)	Emission Level (dBuV/m)	Limits (dBuV/m)	Margin (dB)	Remark
1	2480.000	28.08	6.87	34.45	87.64	88.14	74.00	-14.14	Peak
2	4960.000	33.14	9.69	34.60	46.38	54.61	74.00	19.39	Peak

Remarks:
 1. Emission Level= Antenna Factor + Cable Loss -Amp Factor + Reading.
 2. The emission levels that are 20dB below the official limit are not reported.

Frequency (MHz)	Peak level (dBuV/m)	Duty cycle factor (dB)	AV level (dBuV/m)	Limit(dBuV/m)	Conclusion
4960.000	54.61	8.1	46.51	54	Pass

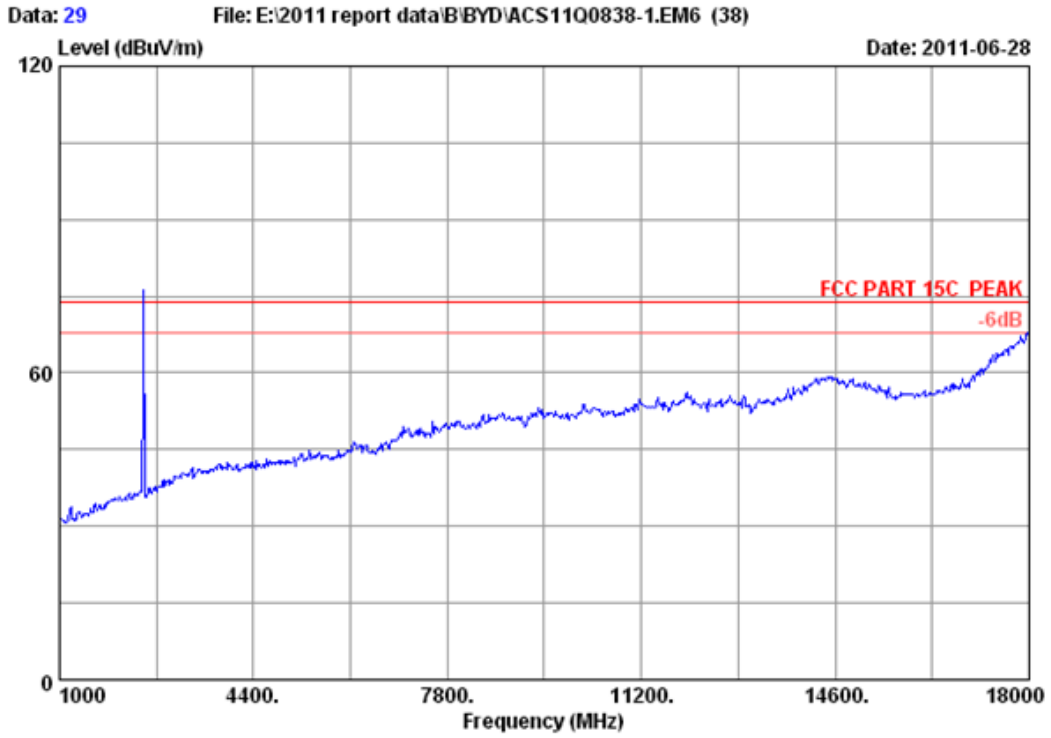

Site no. : 3m Chamber Data no. : 29
Dis. / Ant. : 3m 2011 3115 4580 Ant. pol. : VERTICAL
Limit : FCC PART 15C PEAK
Env. / Ins. : 23°C/54% Engineer : Leo-Li
EUT : Tablet PC
Power : DC 19V From Adapter input AC 120V/60Hz
Test mode : 8DPSK 2480MHz Tx
M/N : T10COT

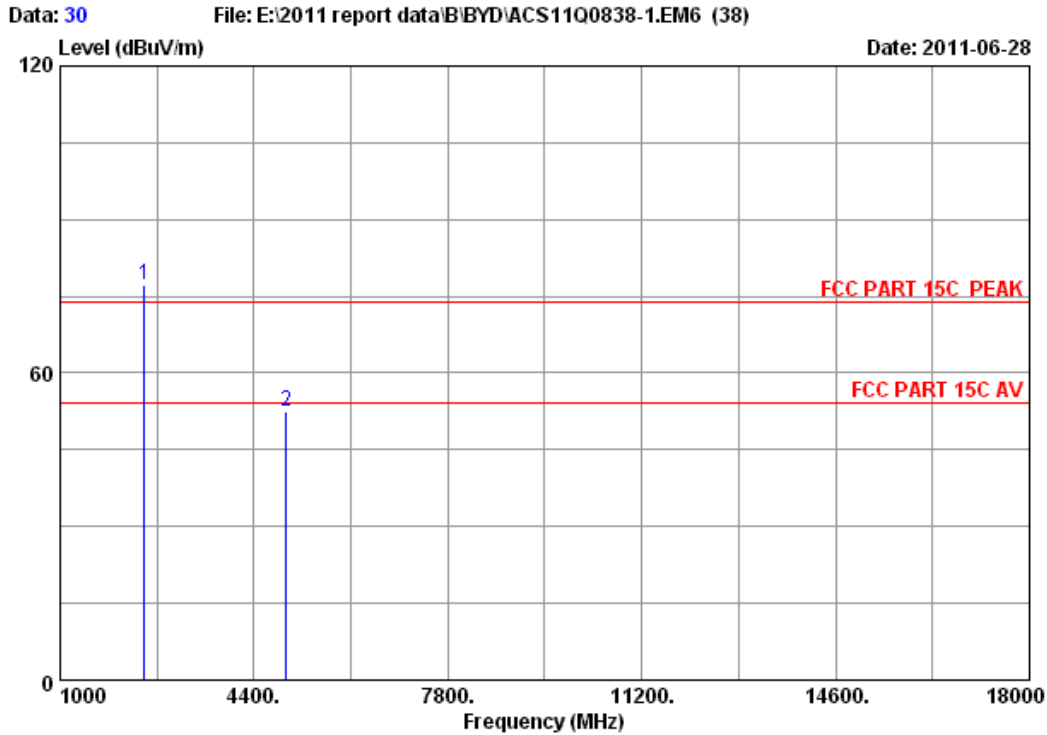

Site no. : 3m Chamber Data no. : 30
 Dis. / Ant. : 3m 2011 3115 4580 Ant. pol. : VERTICAL
 Limit : FCC PART 15C PEAK
 Env. / Ins. : 23°C/54% Engineer : Leo-Li
 EUT : Tablet PC
 Power supply : DC 19V From Adapter input AC 120V/60Hz
 Test mode : 8DPSK 2480MHz Tx
 M/N : T10COT

	Freq. (MHz)	Ant. Factor (dB/m)	Cable loss (dB)	Amp. Factor (dB)	Reading (dBuV)	Emission Level (dBuV/m)	Limits (dBuV/m)	Margin (dB)	Remark
1	2480.000	28.08	6.87	34.45	76.87	77.37	74.00	-3.37	Peak
2	4960.000	33.14	9.69	34.60	44.35	52.58	74.00	21.42	Peak

Remarks:

1. Emission Level= Antenna Factor + Cable Loss -Amp Factor + Reading.
2. The emission levels that are 20dB below the official limit are not reported.

5. CONDUCTED SPURIOUS EMISSIONS

5.1. Test Equipment

Item	Equipment	Manufacturer	Model No.	Serial No.	Last Cal.	Cal. Interval
1.	Spectrum Analyzer	Agilent	E4446A	US44300459	May.08,11	1 Year
2.	Attenuator	Agilent	8491B	MY39262165	May.08,11	1 Year
3.	RF Cable	Hubersuhner	SUCOFLEX102	28618/2	May.08,11	1Year

5.2. Limit

In any 100kHz bandwidth outside the frequency bands in which the spread spectrum intentional radiator is operating, the radio frequency power that is produced by the intentional radiator shall be at least 20dB below that in the 100kHz bandwidth within the band that contains the highest level of the desired power.

5.3. Test Procedure

The transmitter output was connected to a spectrum analyzer, The resolution bandwidth is set to 100 kHz, The video bandwidth is set to 300 kHz and measure all the emissions detected.

5.4. Test result

PASS (The testing data was attached in the next pages.)

**Hopping off
GFSK
2402**

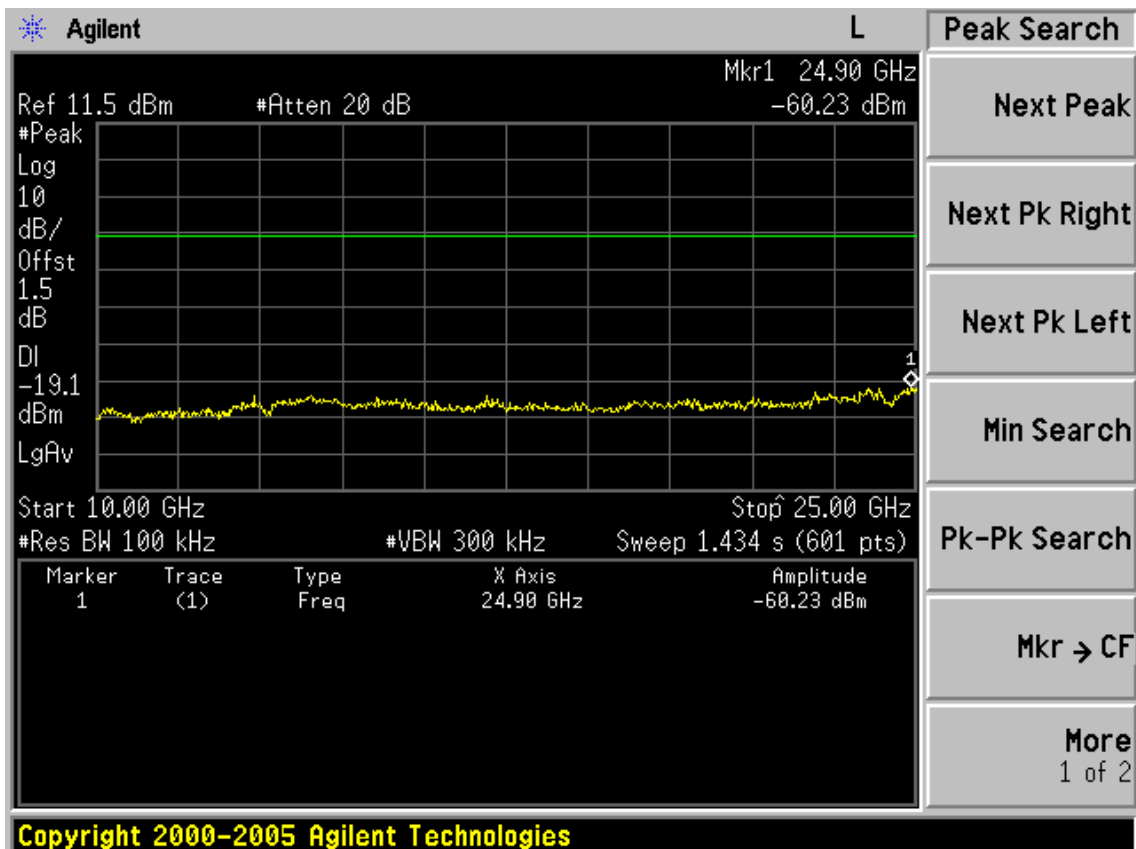
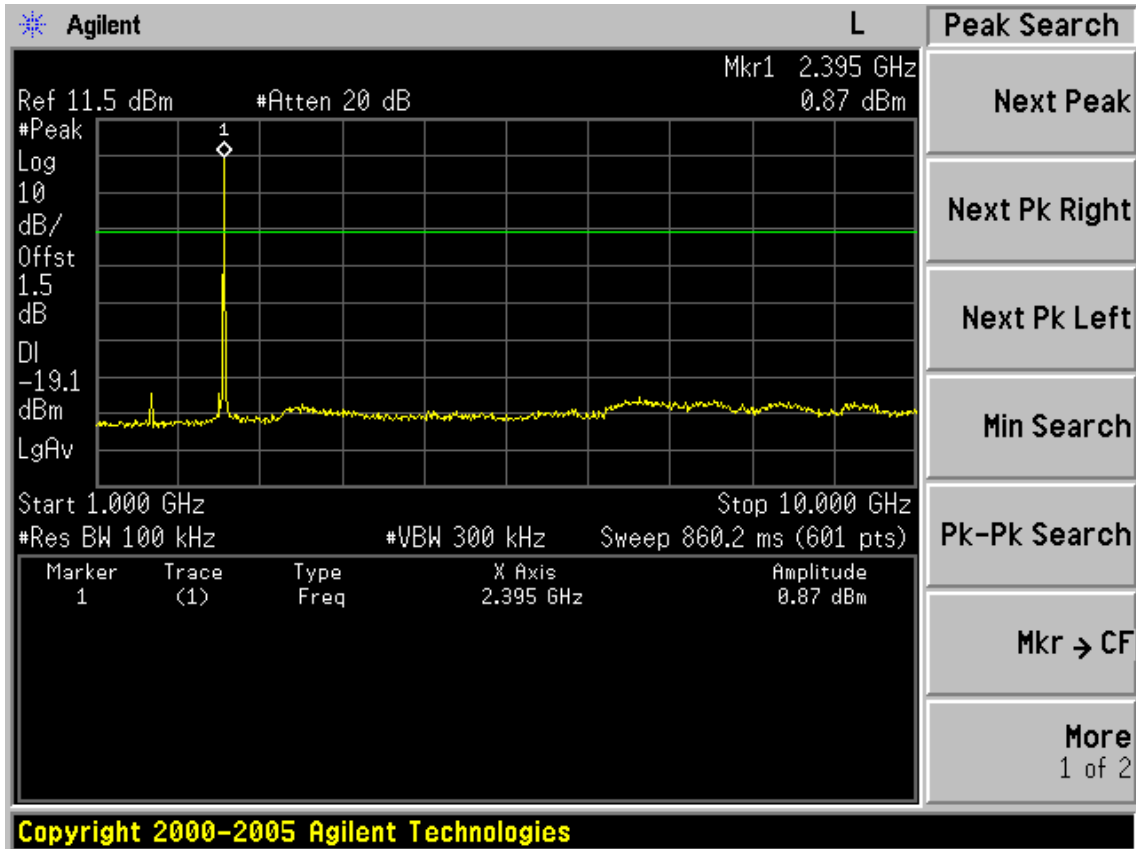

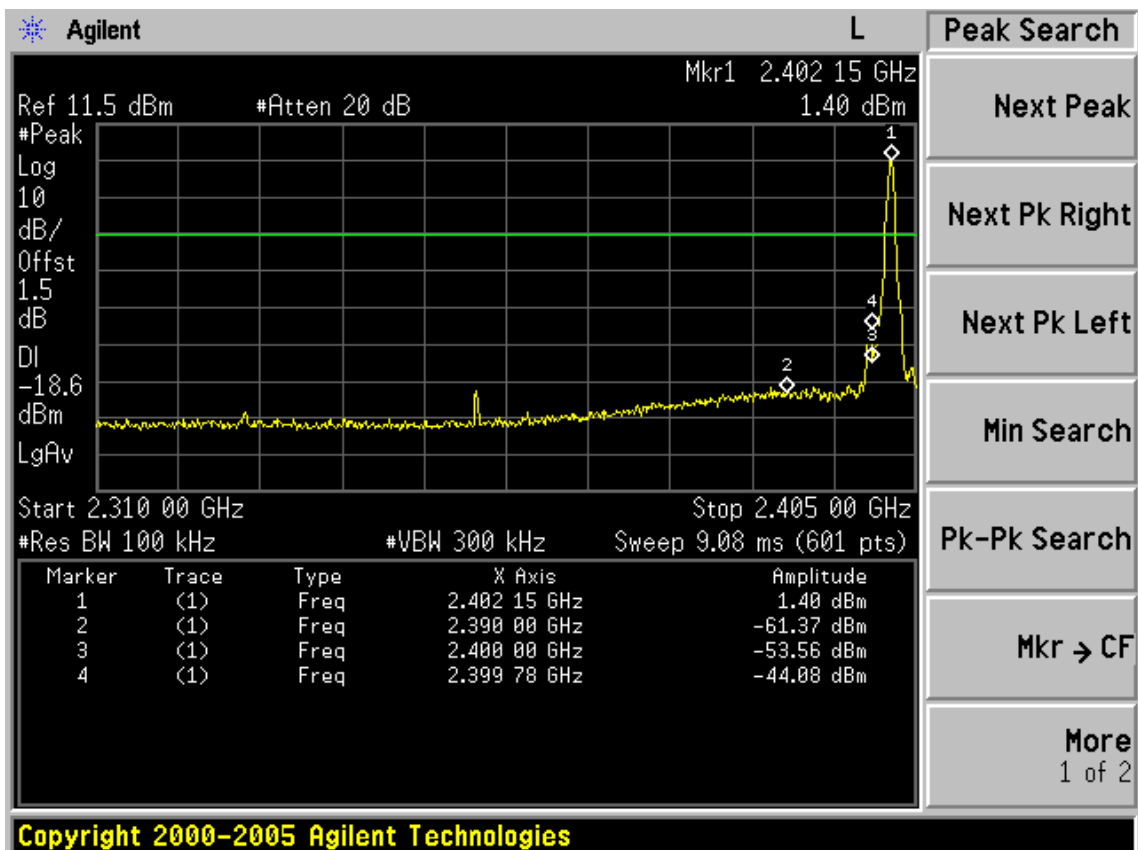
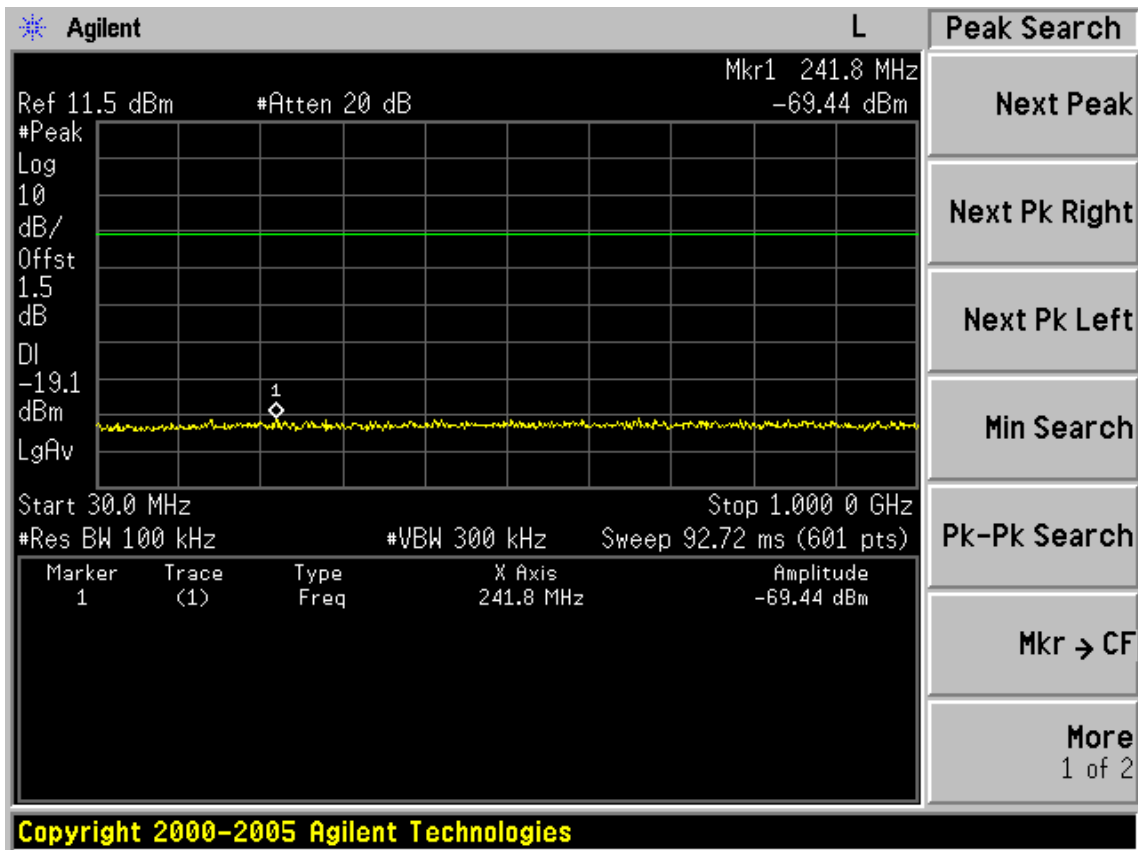

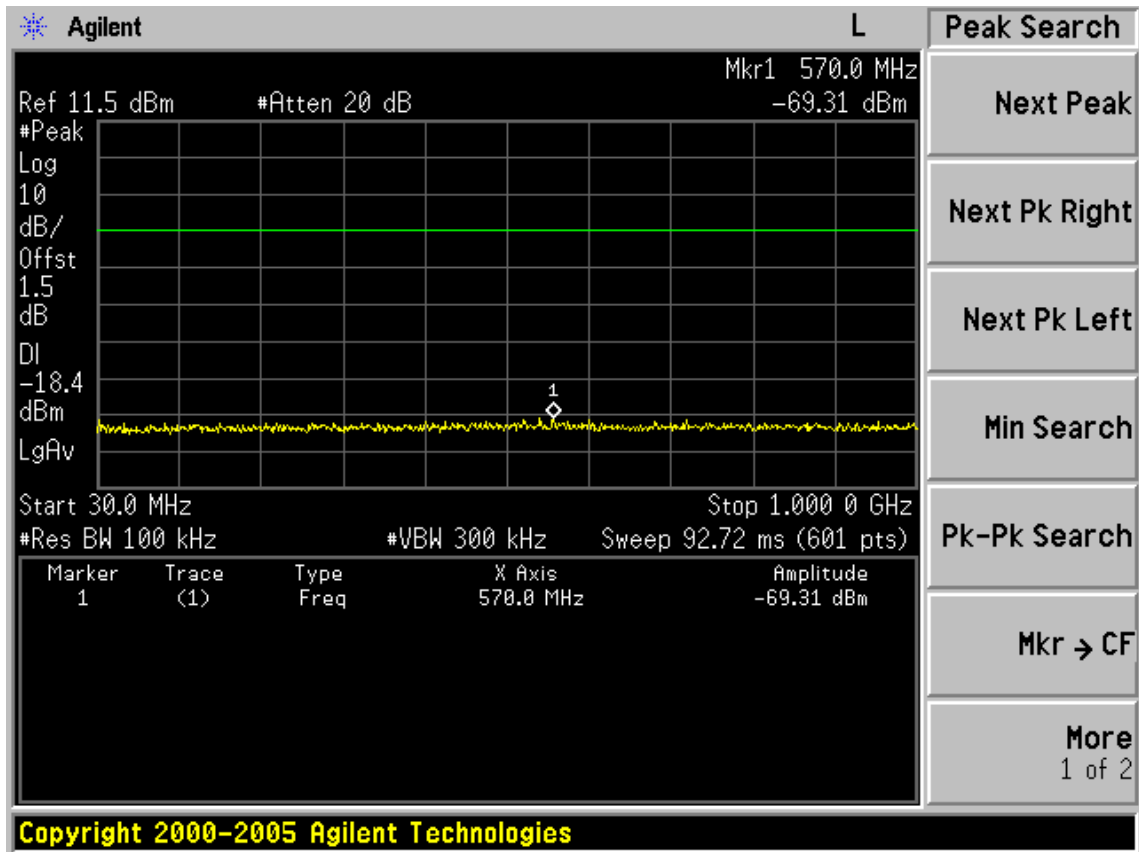
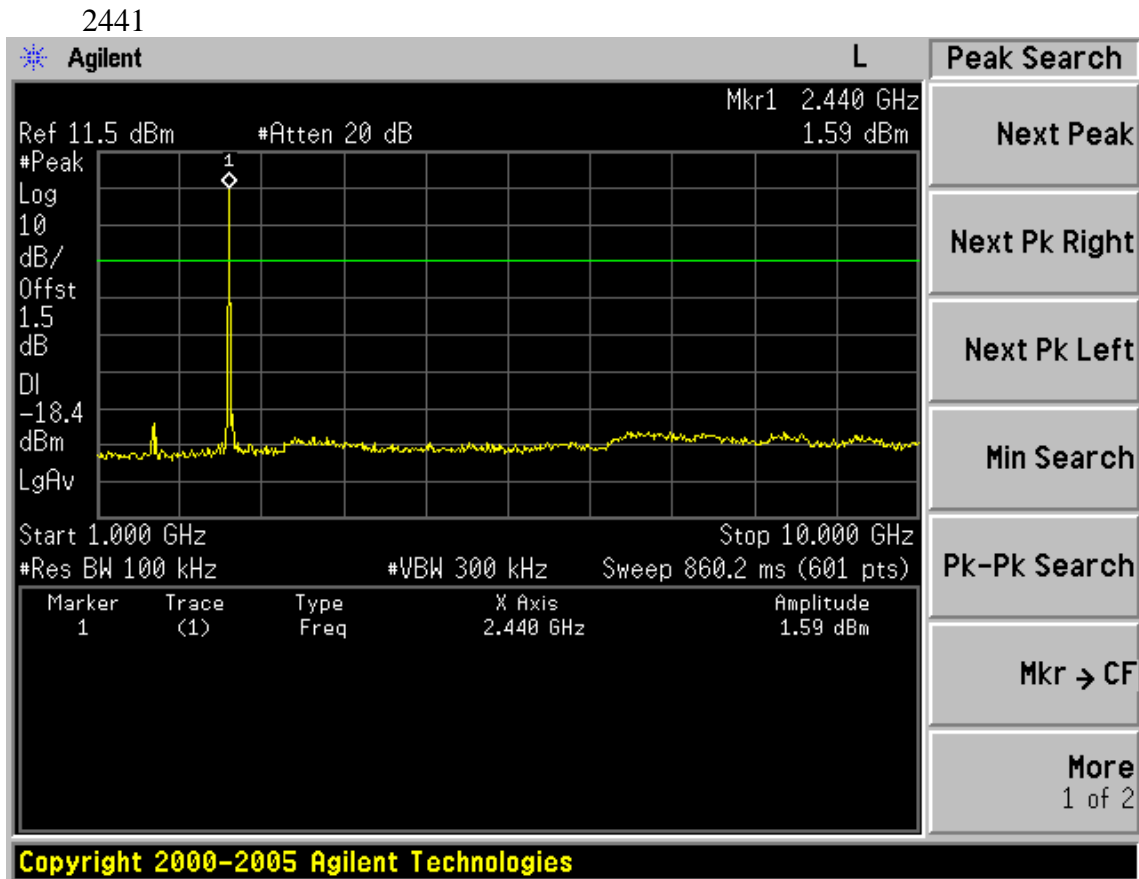

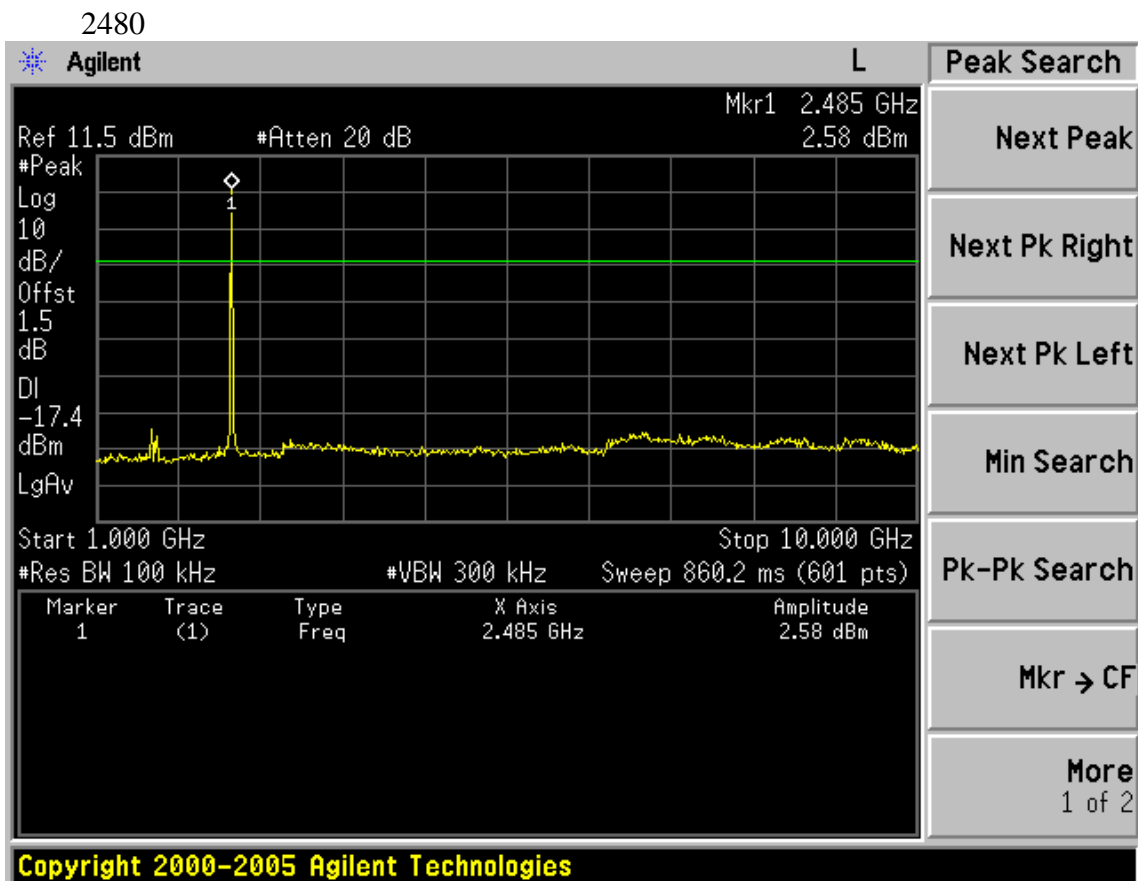
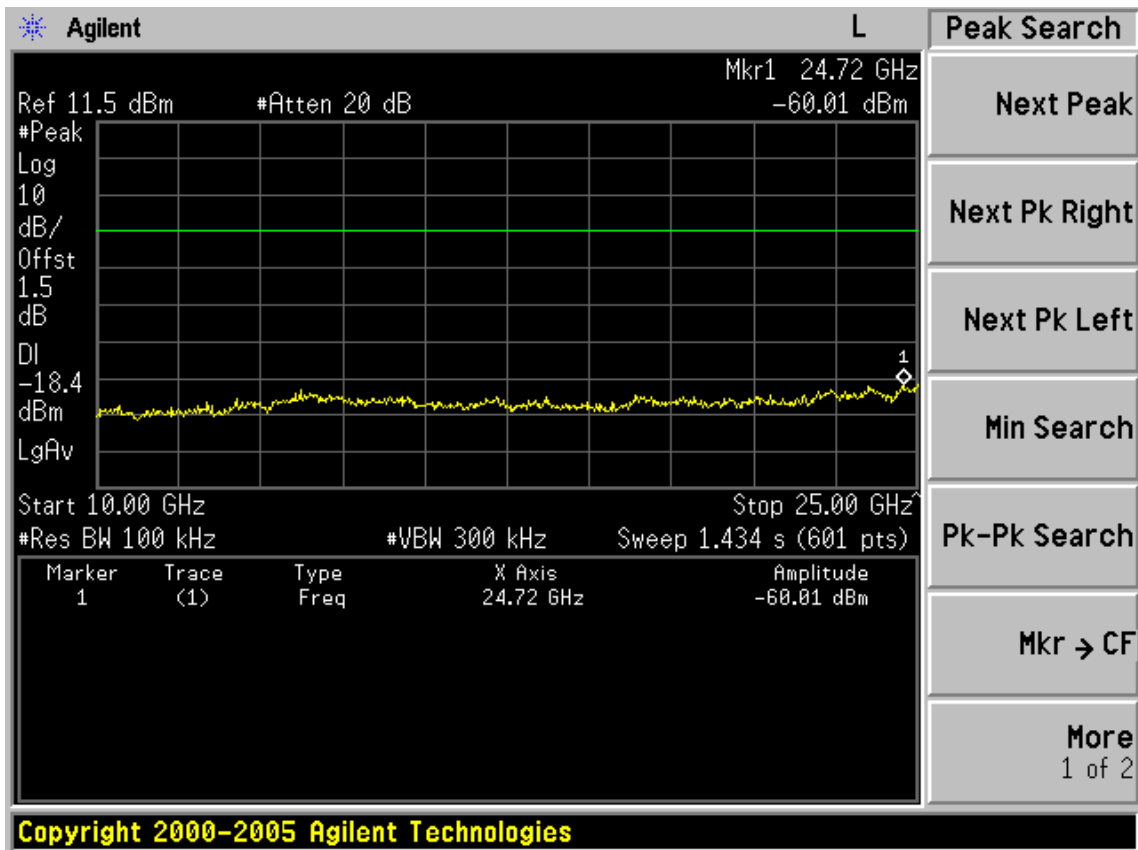

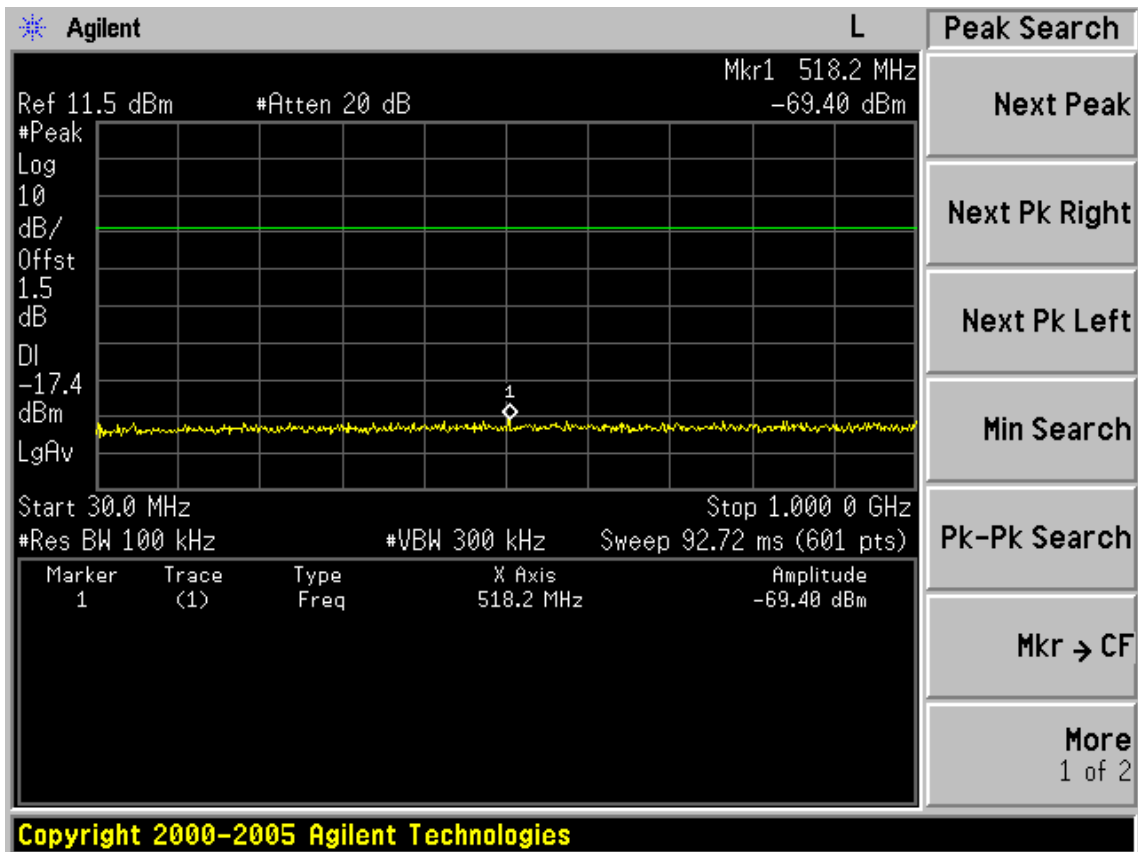
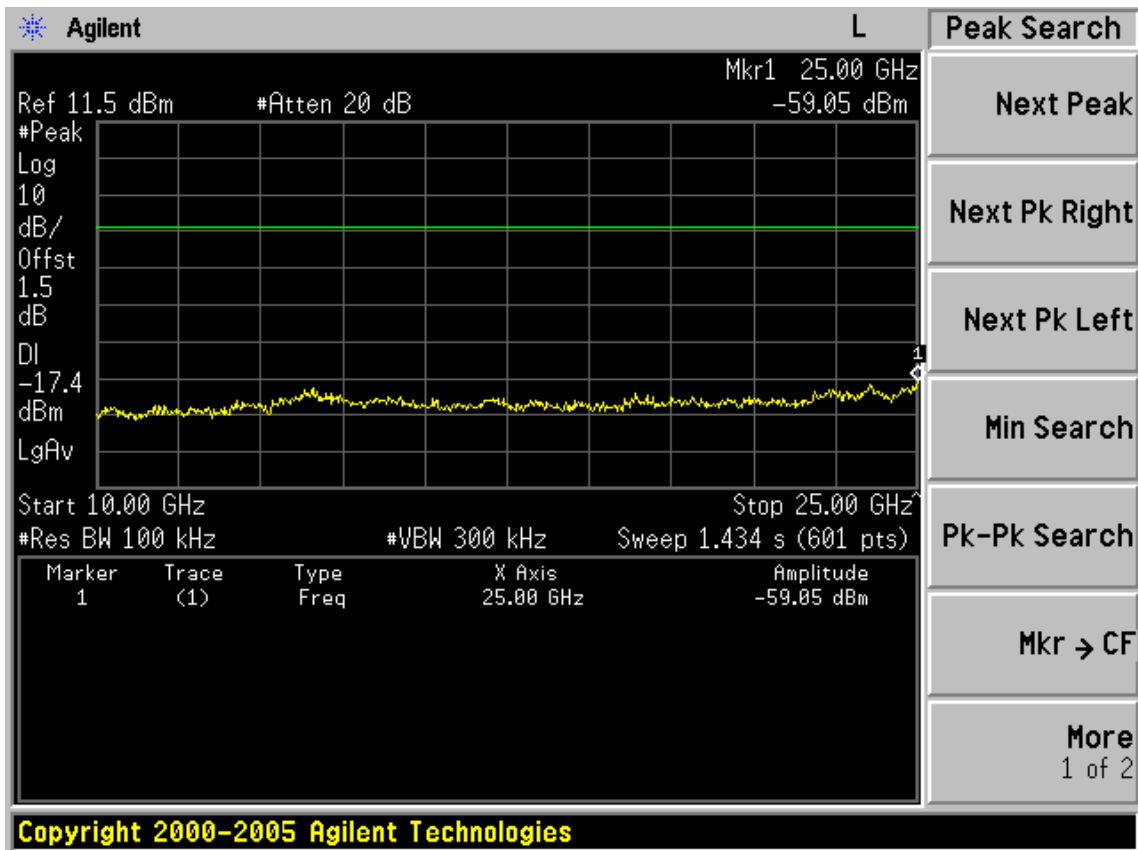

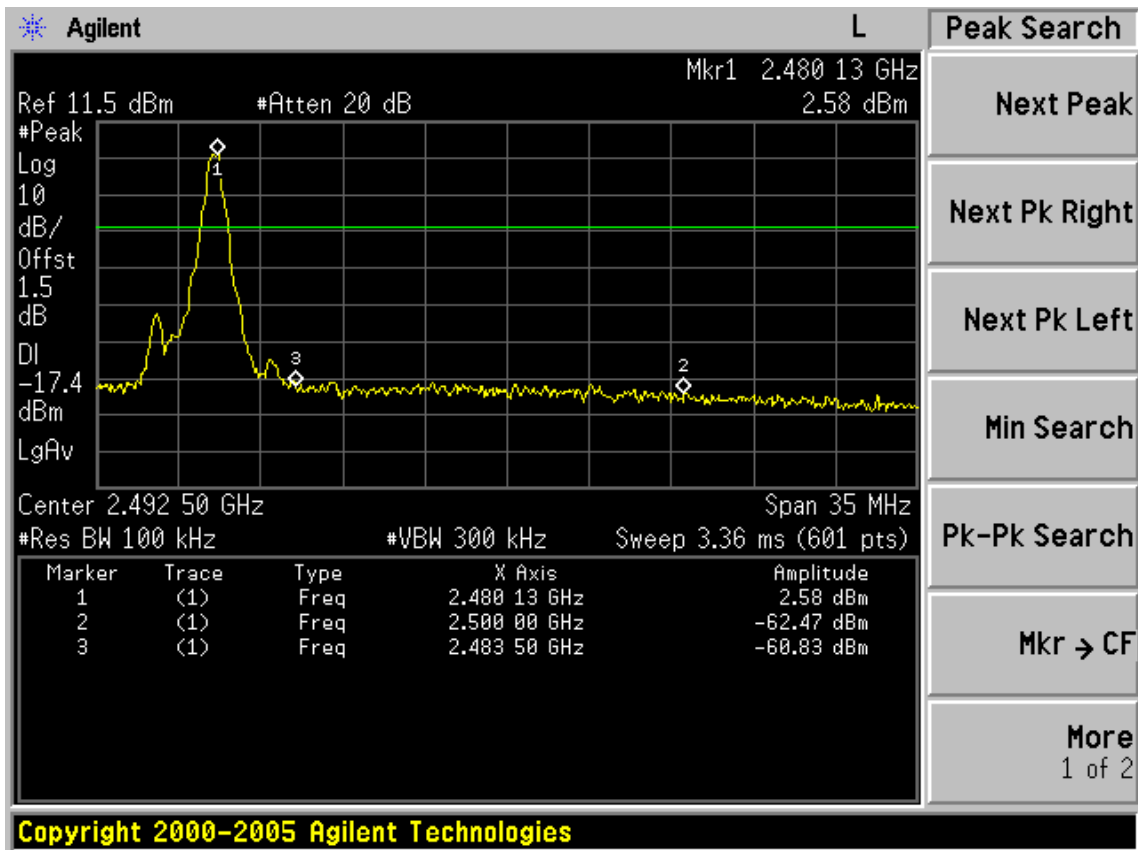

8DPSK

2402

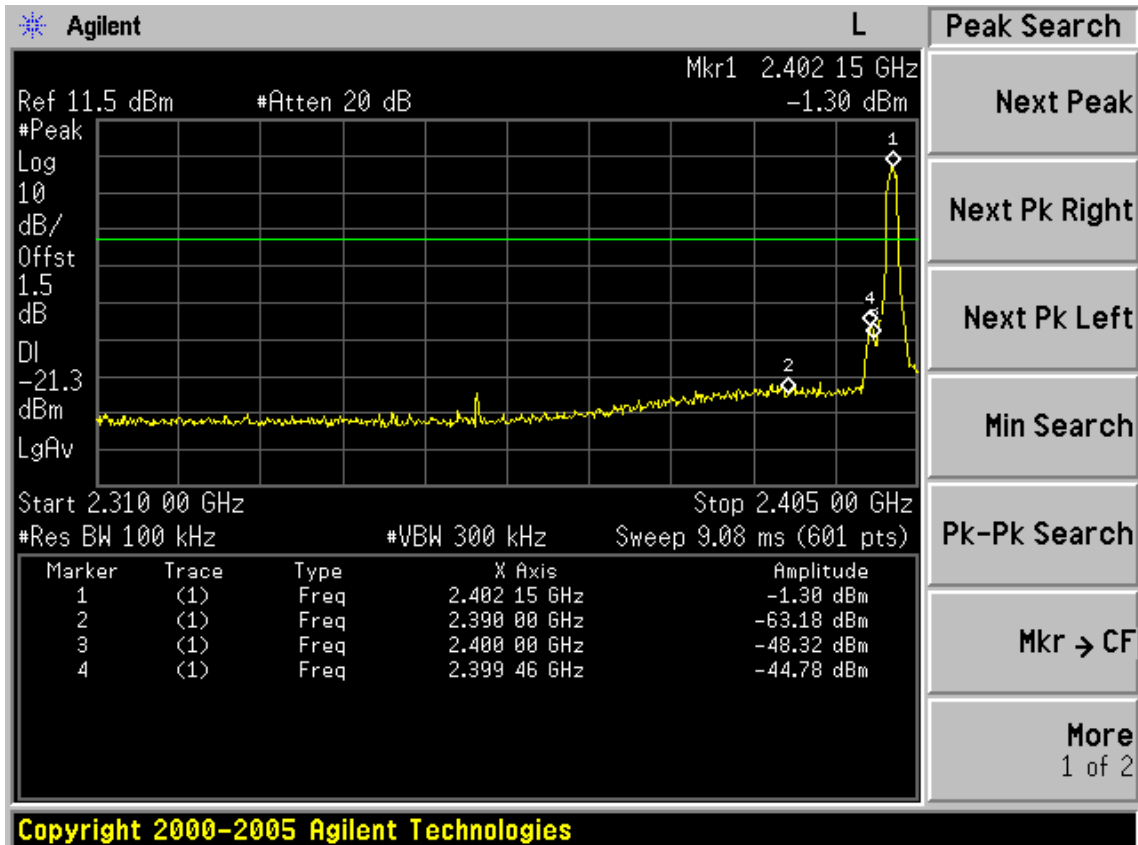

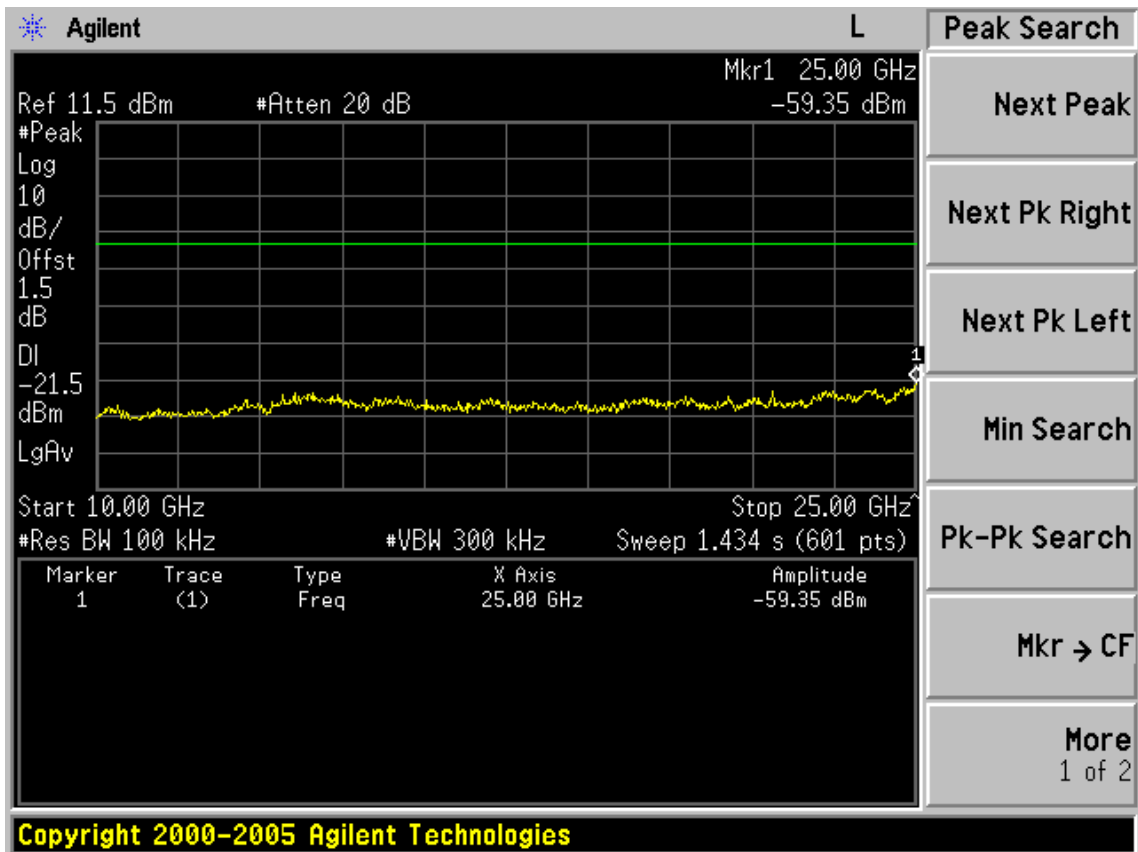
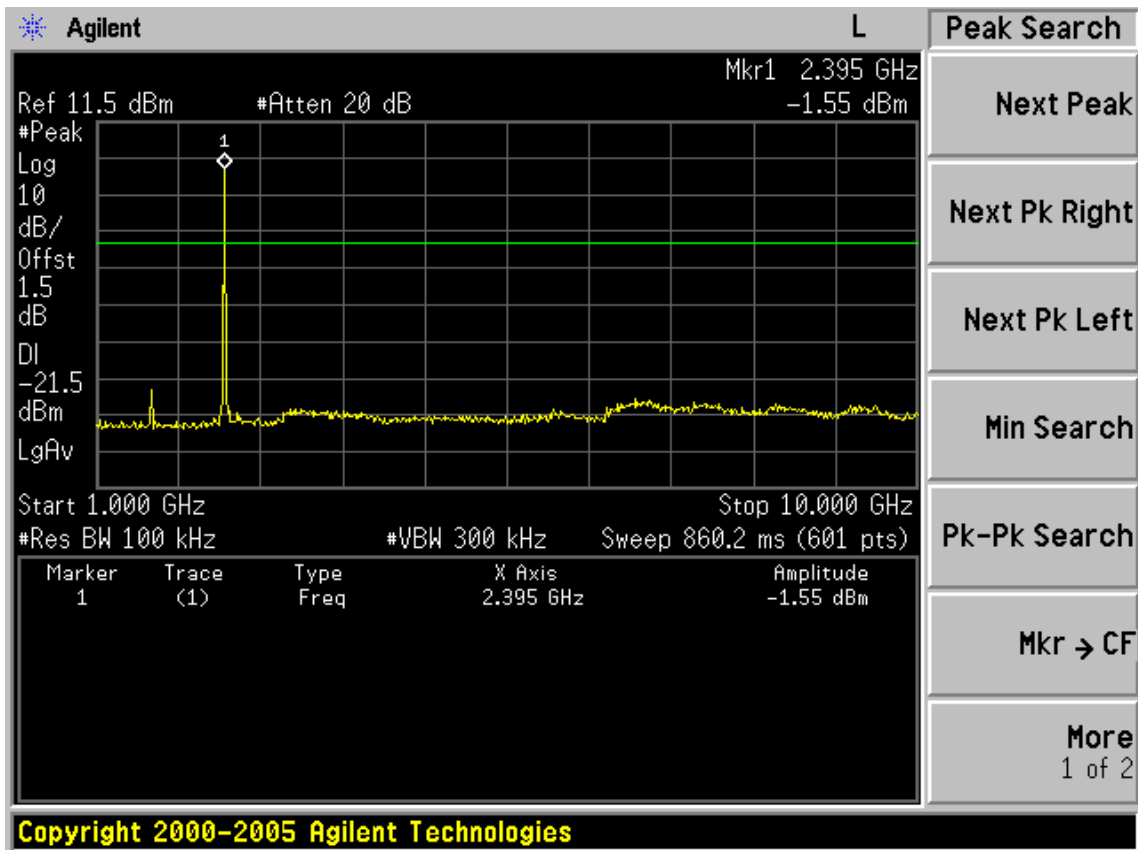

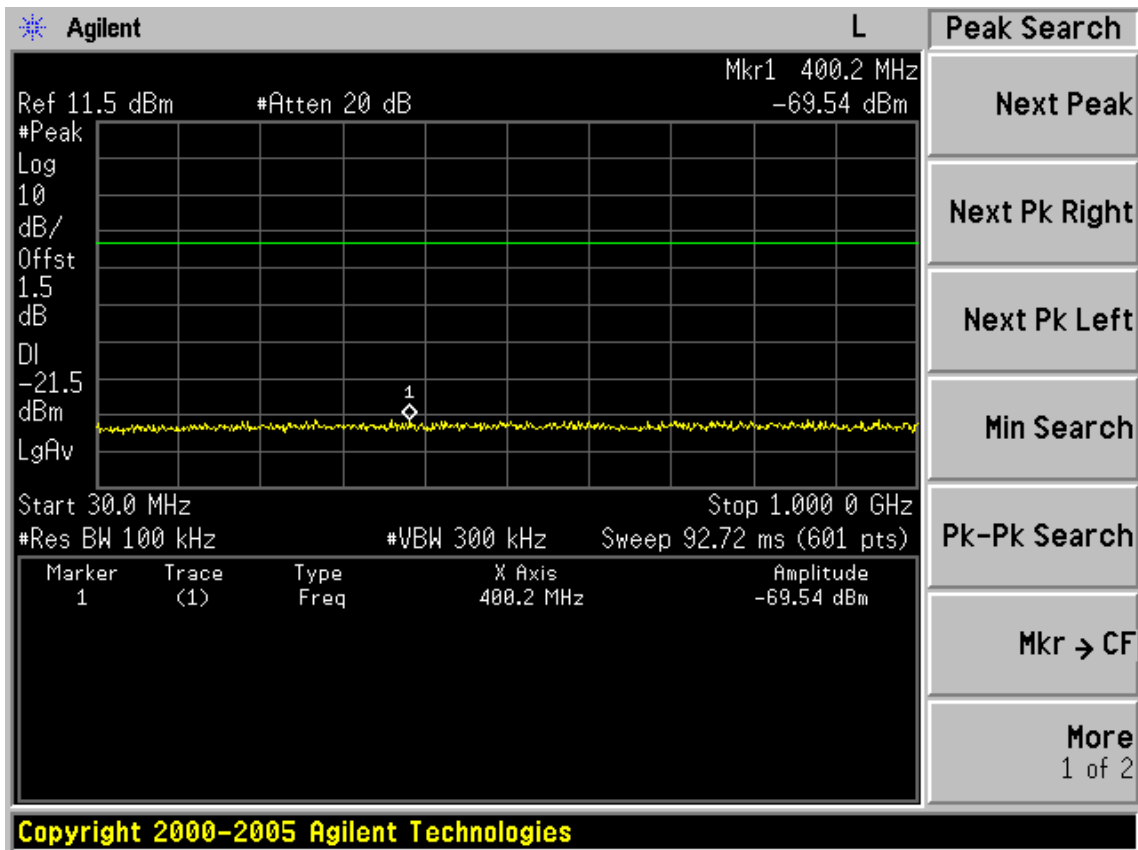

2442

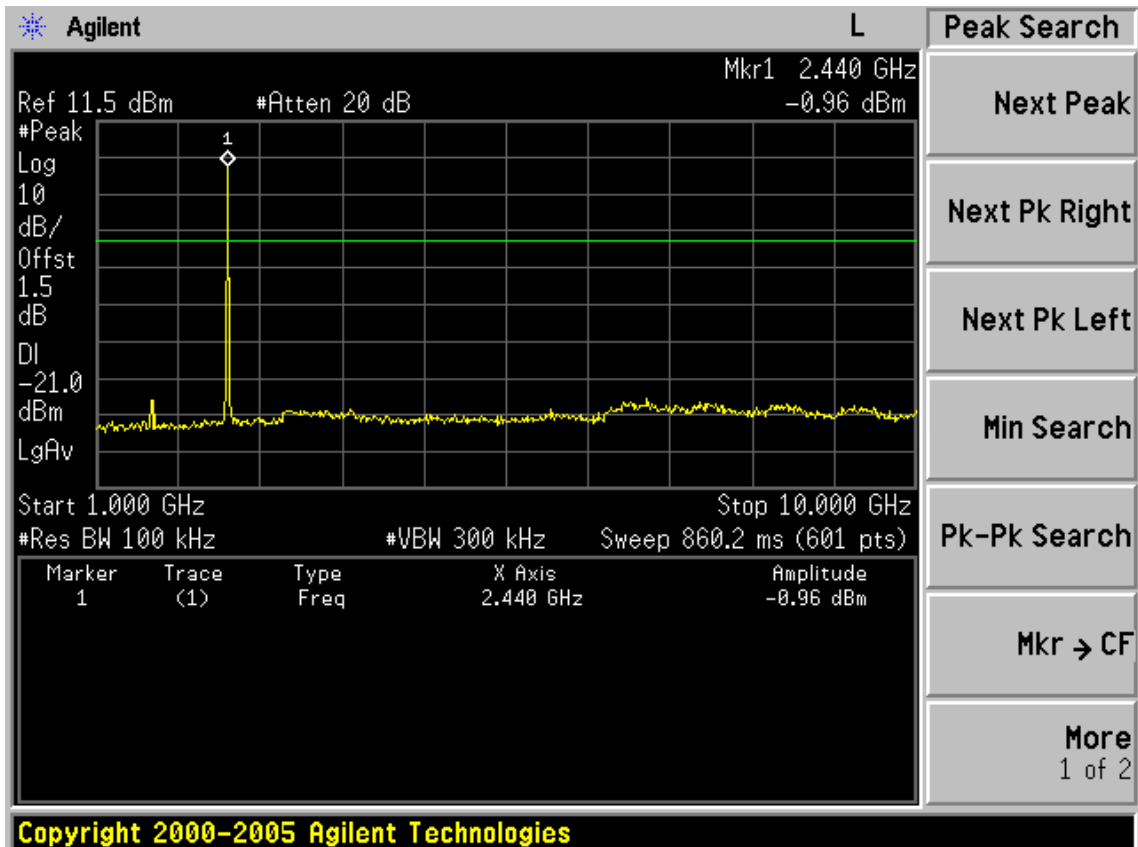

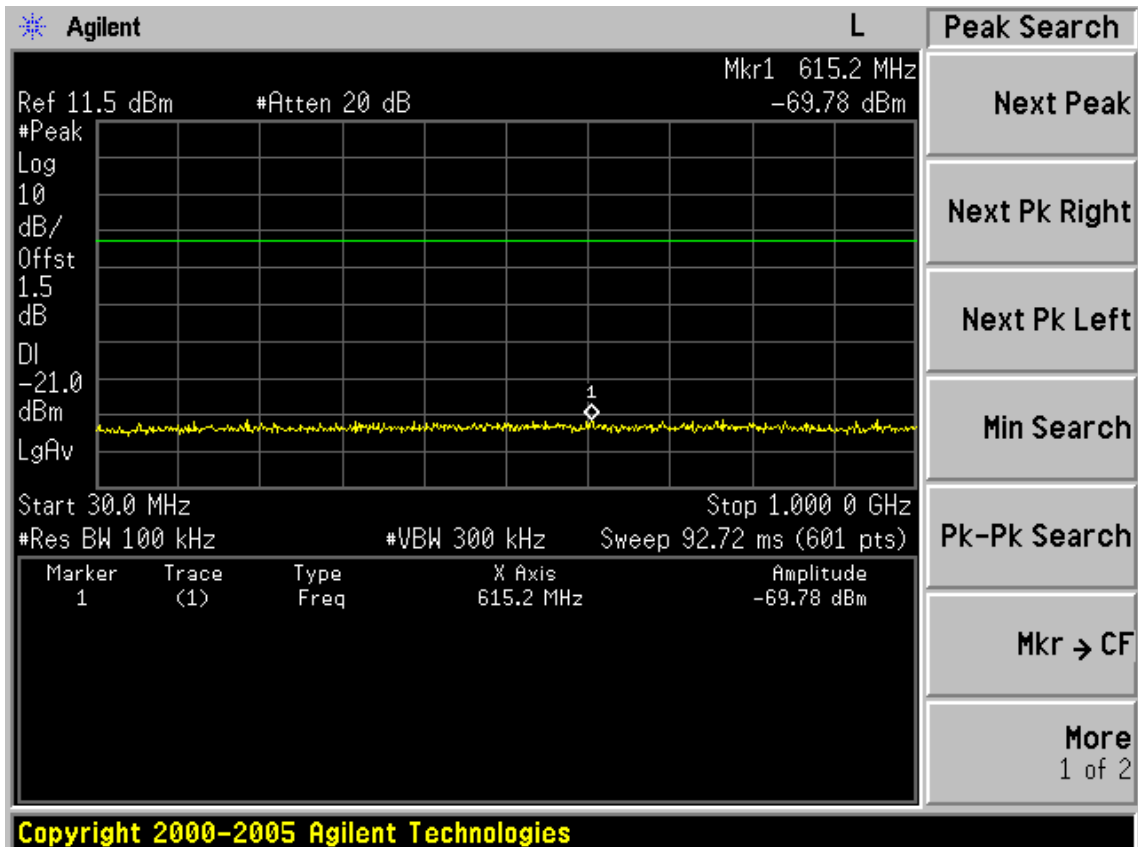
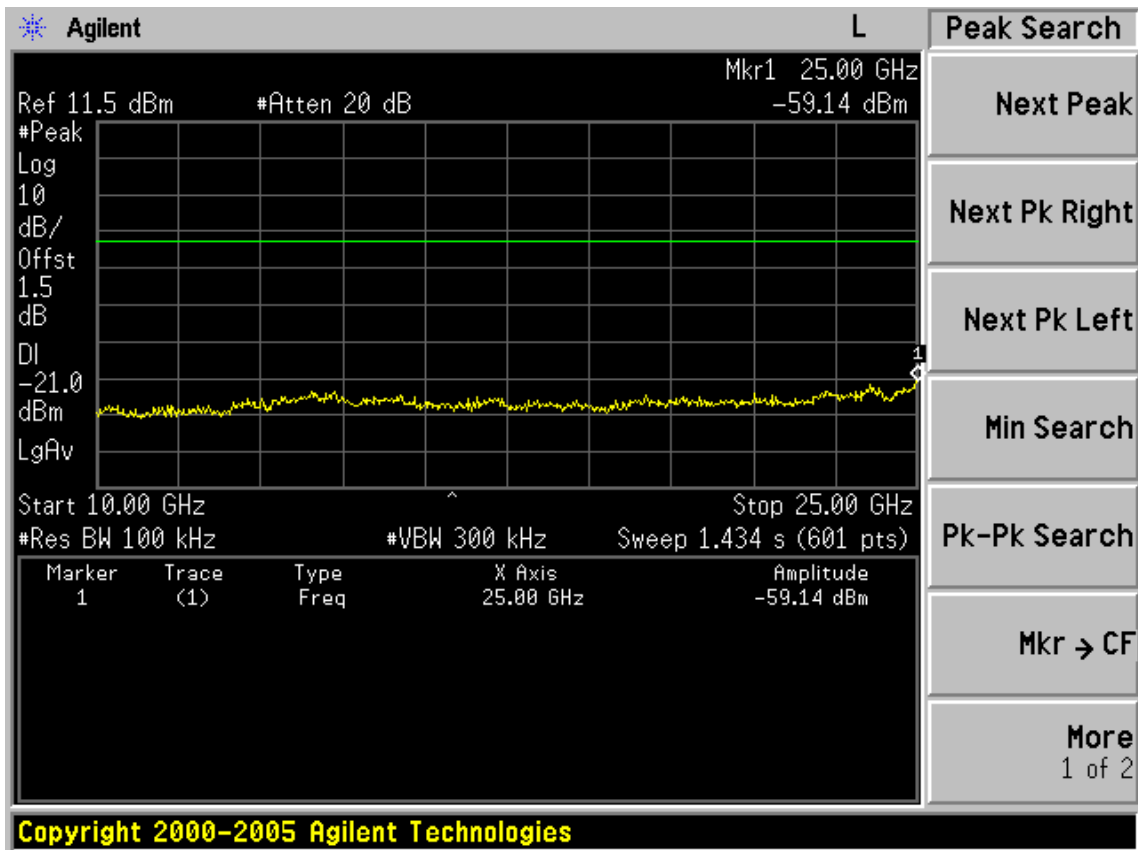

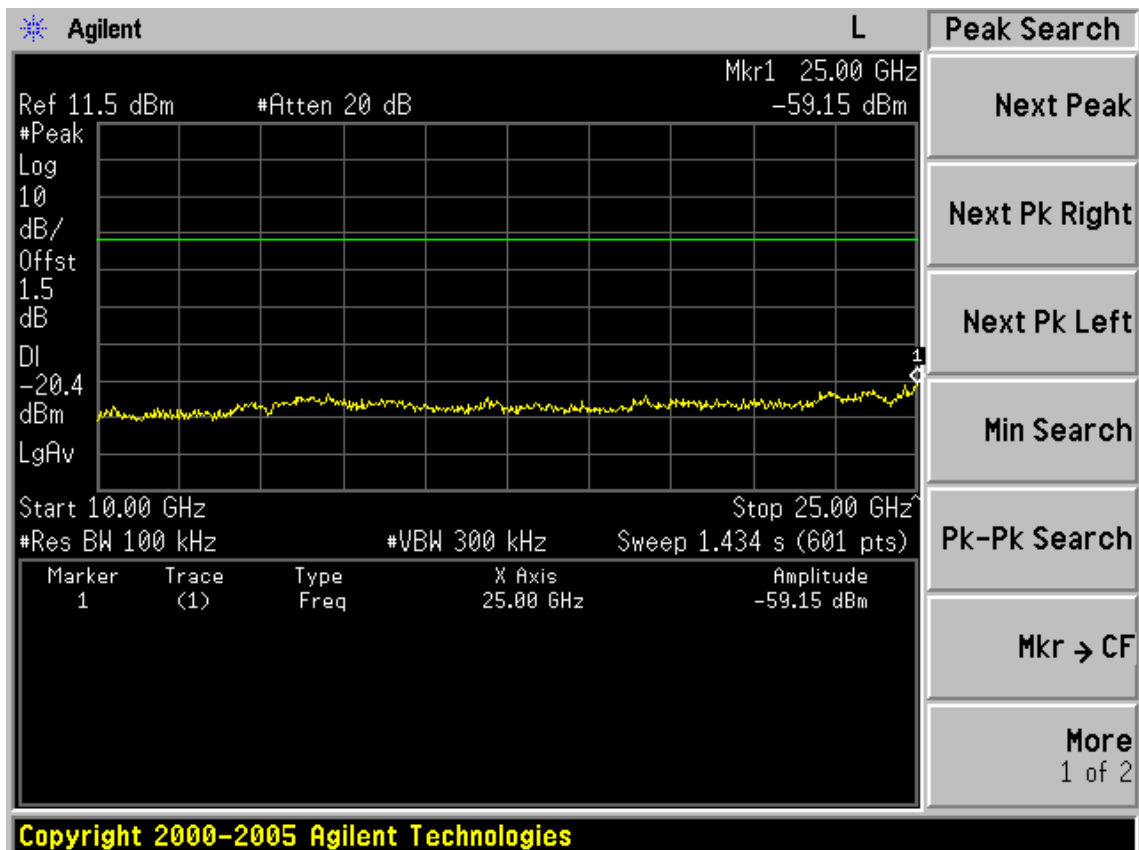
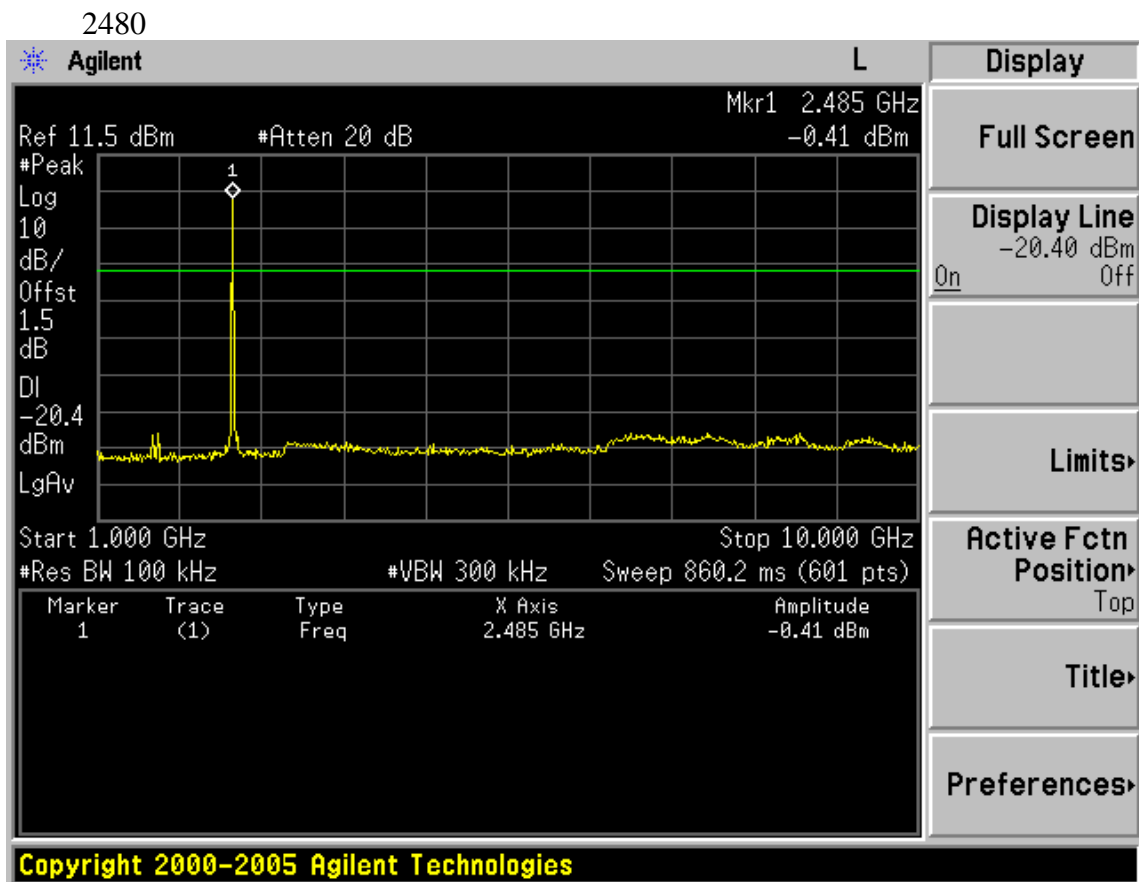

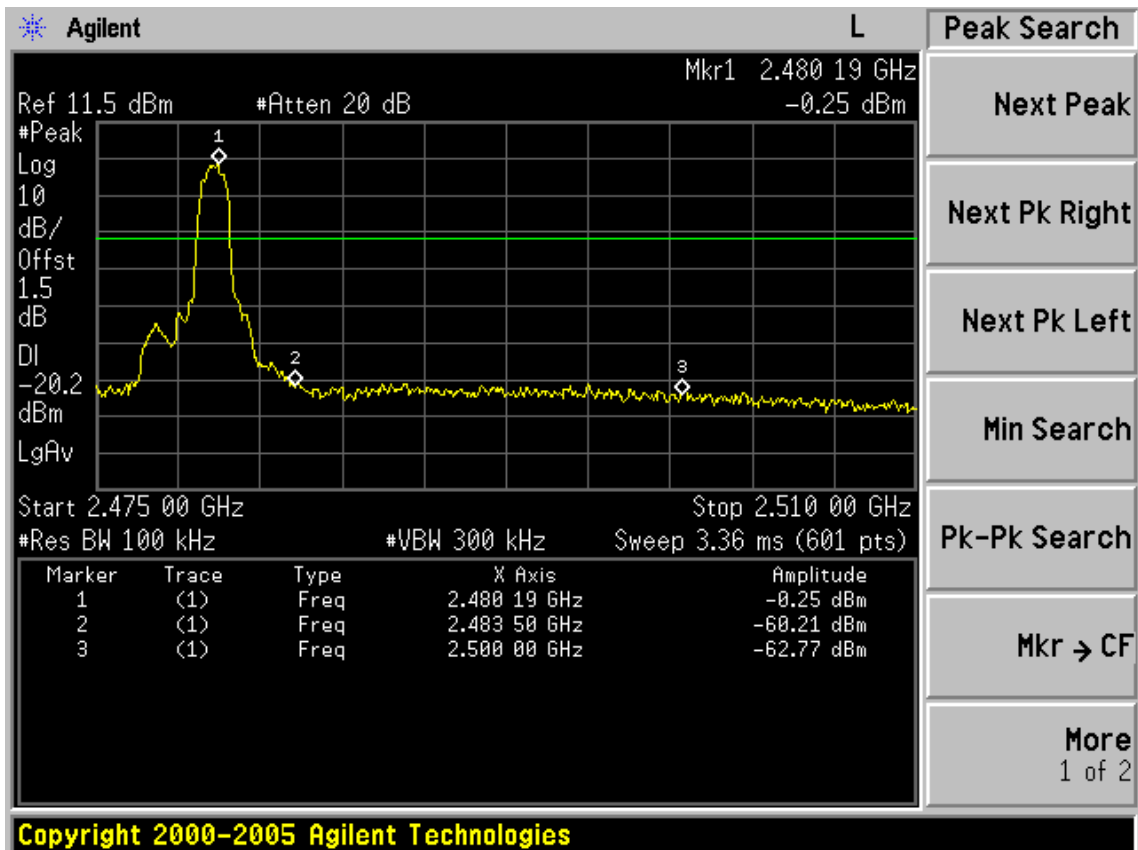
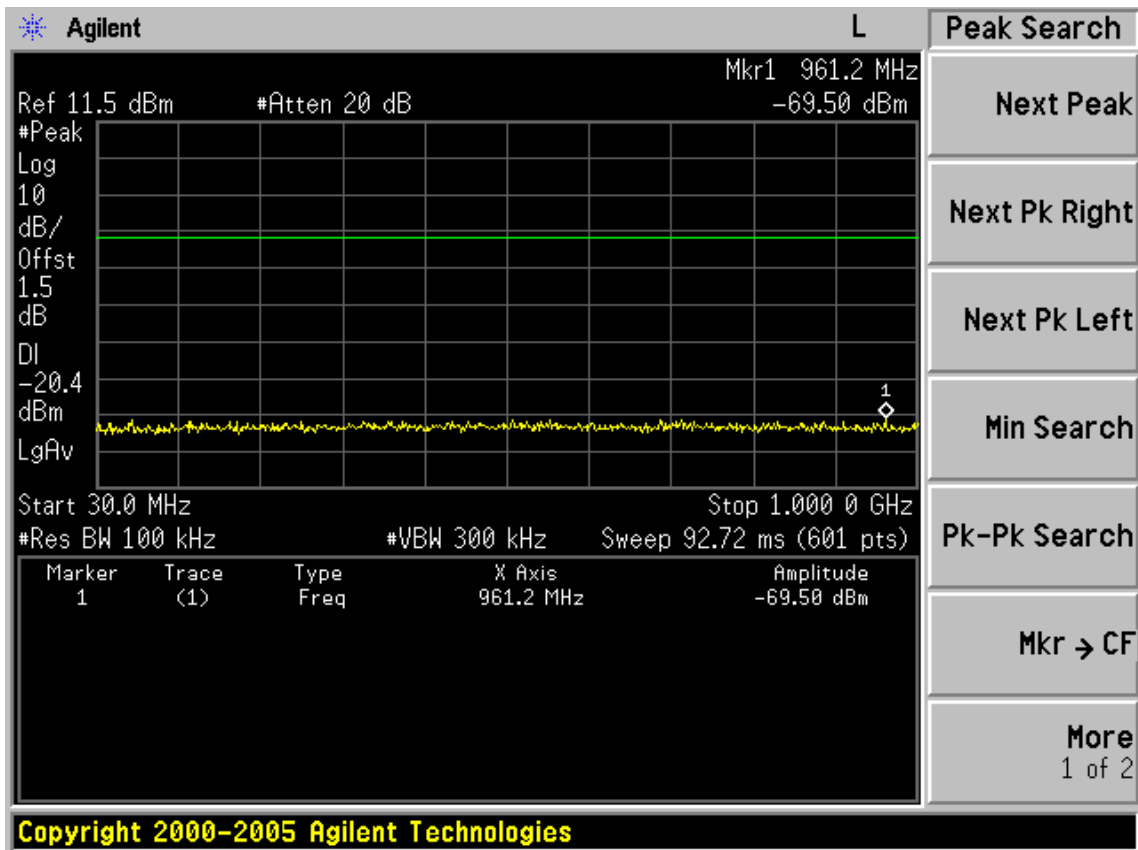

Hopping on GFSK

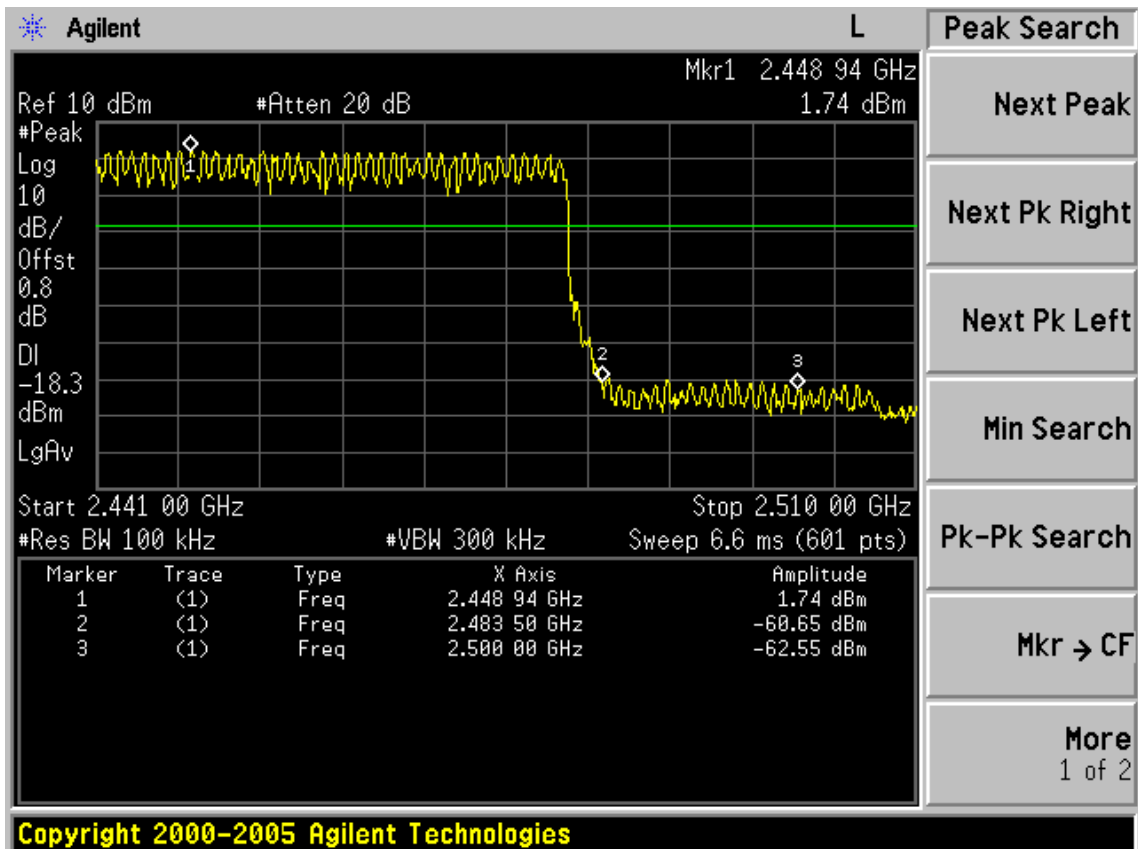
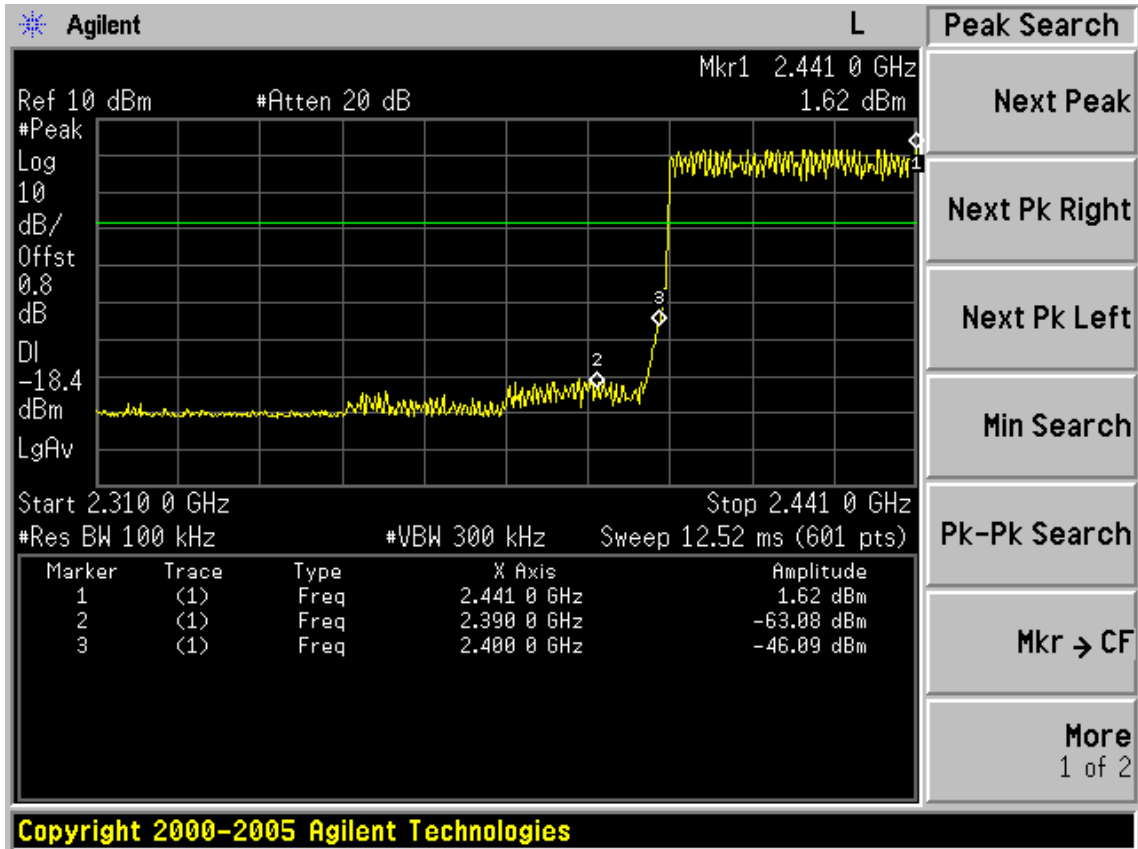

8DPSK

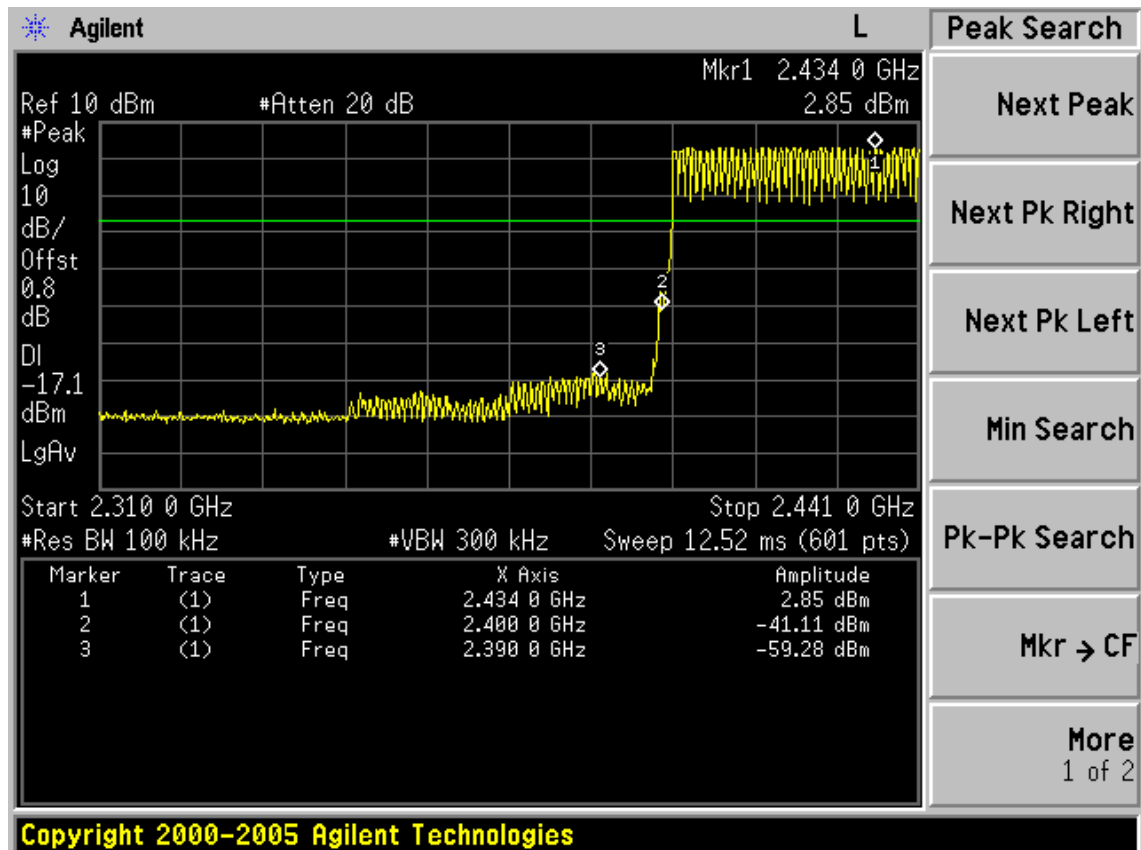
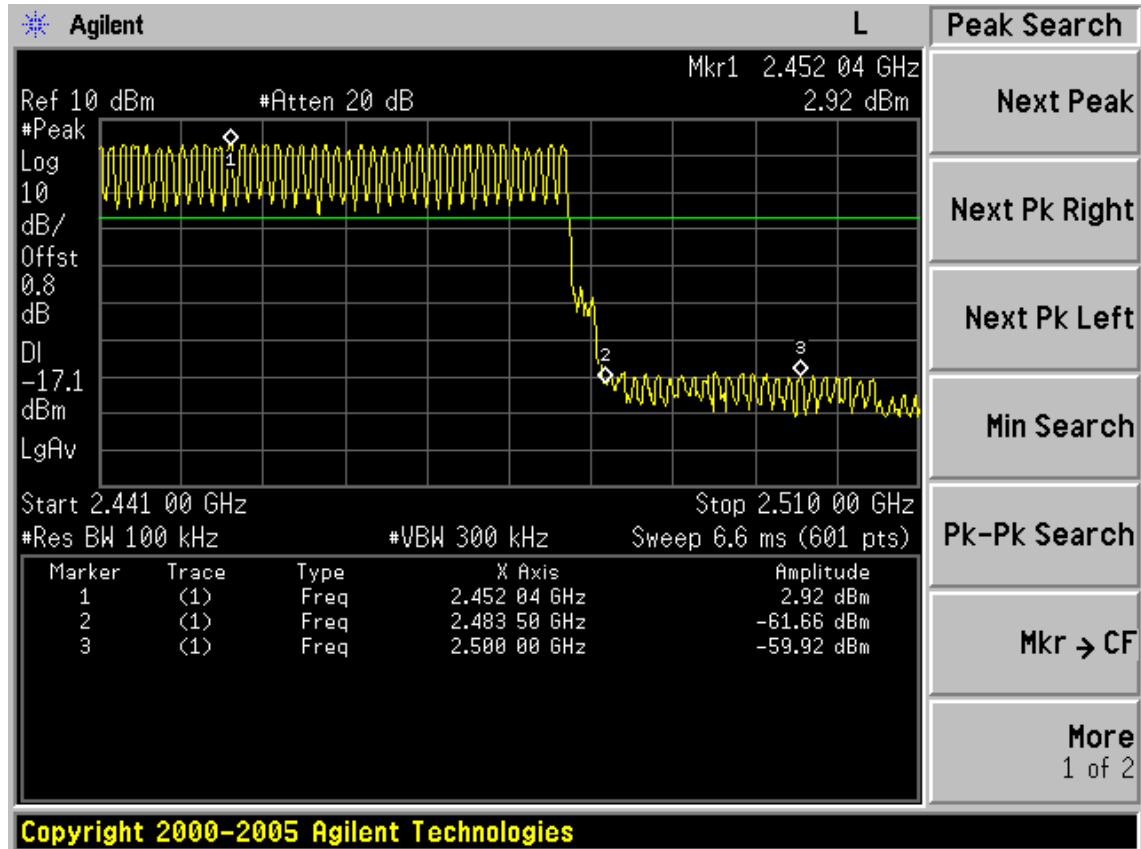

6. CARRIER FREQUENCY SEPARATION TEST

6.1. Test Equipment

Item	Equipment	Manufacturer	Model No.	Serial No.	Last Cal.	Cal. Interval
1	Spectrum Analyzer	Agilent	E4446A	US44300459	May.08, 11	1 Year

6.2. Limit

Frequency hopping systems shall have hopping channel carrier frequency separated by a minimum of 25kHz or the 20dB bandwidth of the hopping channel, whichever is greater. Alternatively, frequency hopping systems operating in the 2400-2483.5 MHz band may have hopping channel carrier frequencies that are separated by 25 kHz or two-thirds of the 20 dB bandwidth of the hopping channel, whichever is greater, provided the systems operate with an output power no greater than 125 mW.

6.3. Test Results.

EUT: Tablet PC		
M/N: T10COT		
Test date:2011-07-28	Pressure:100.6 kpa	Humidity:53%
Tested by: Leo-Li	Test site: RF site	Temperature:25 °C

Channel separation	Conclusion
1.00MHz	PASS

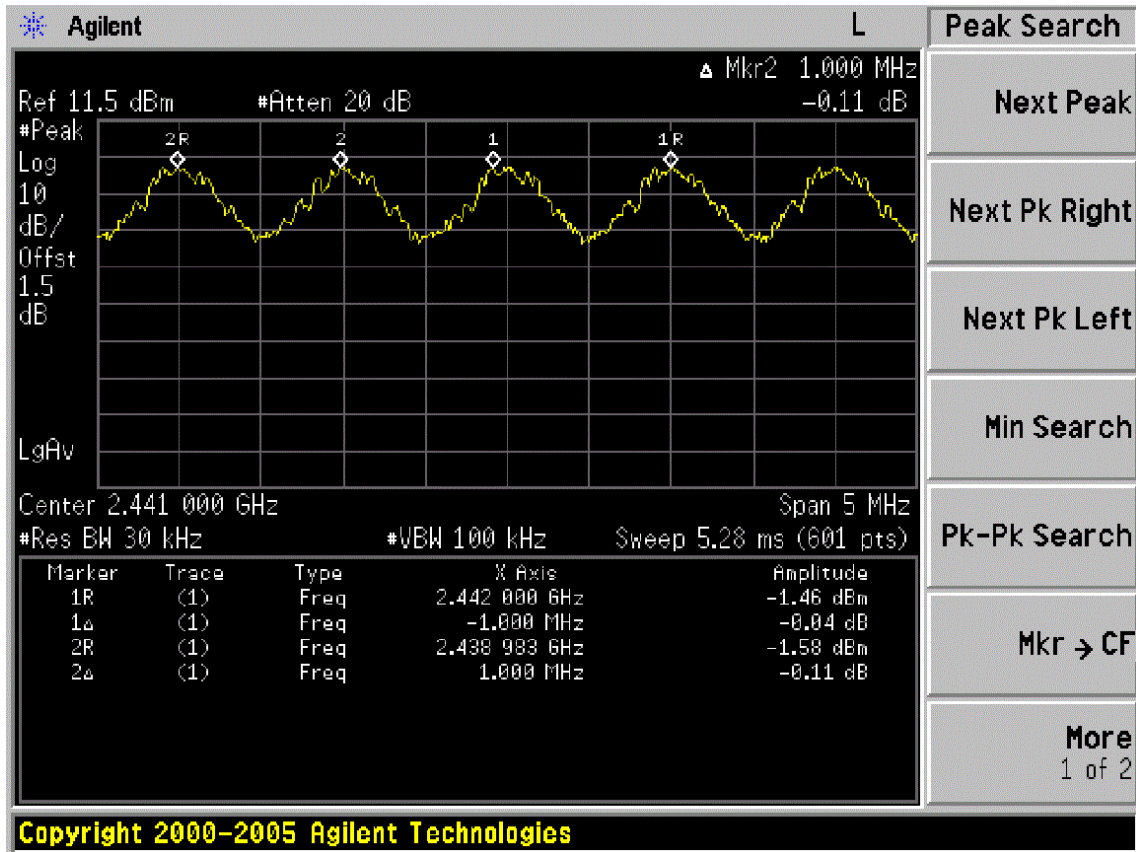

7. 20 DB BANDWIDTH TEST

7.1. Test Equipment

Item	Equipment	Manufacturer	Model No.	Serial No.	Last Cal.	Cal. Interval
1.	Spectrum Analyzer	Agilent	E4446A	US44300459	May.08,11	1 Year

7.2. Limit

Intentional radiators operating under the alternative provisions to the general emission limits, as contained in §§ 15.217 through 15.257 and in Subpart E of this part, must be designed to ensure that the 20 dB bandwidth of the emission, or whatever bandwidth may otherwise be specified in the specific rule section under which the equipment operates, is contained within the frequency band designated in the rule section under which the equipment is operated.

7.3. Test Results

EUT: Tablet PC		
M/N: T10COT		
Test date: 2011-06-29	Pressure: 100.7 kpa	Humidity: 56%
Tested by: Leo-Li	Test site: RF Site	Temperature : 24.8 °C

Cable loss: 1.50 dB		Attenuator loss: 20 dB	Antenna Gain: 2.0 dBi
Test Mode	CH (MHz)	20dB bandwidth (MHz)	Limit (KHz)
GFSK	2402	0.999068	N/A
	2441	1.010	N/A
	2480	1.023	N/A
8DPSK	2402	1.268	N/A
	2441	1.269	N/A
	2480	1.269	N/A
Conclusion : PASS			

GFSK

Test Frequency: 2402MHz

<p>Agilent L</p> <p>Ch Freq 2.402 GHz Trig Free</p> <p>Occupied Bandwidth</p> <p>Center 2.402000000 GHz</p> <p>Ref 11.5 dBm #Atten 20 dB</p> <p>#Peak</p> <p>Log</p> <p>10</p> <p>dB/</p> <p>Offst</p> <p>1.5</p> <p>dB</p> <p>Center 2.402 000 GHz Span 3 MHz</p> <p>#Res BW 30 kHz #VBW 100 kHz Sweep 3.2 ms (601 pts)</p> <p>Occupied Bandwidth 895.2733 kHz Occ BW % Pwr 99.00 %</p> <p>x dB Bandwidth 999.068 kHz x dB -20.00 dB</p> <p>Transmit Freq Error 9.333 kHz</p> <p>x dB Bandwidth 999.068 kHz</p>		<p>Trace</p> <p>Trace 1 2 3</p> <p>Clear Write</p> <p>Max Hold</p> <p>Min Hold</p> <p>View</p> <p>Blank</p> <p>More 1 of 2</p>
---	--	--

File Operation Status, A:\SCREN602.GIF file saved

Test Frequency: 2441MHz

<p>Agilent L</p> <p>Ch Freq 2.441 GHz Trig Free</p> <p>Occupied Bandwidth</p> <p>Center 2.441000000 GHz</p> <p>Ref 11.5 dBm #Atten 20 dB</p> <p>#Peak</p> <p>Log</p> <p>10</p> <p>dB/</p> <p>Offst</p> <p>1.5</p> <p>dB</p> <p>Center 2.441 000 GHz Span 3 MHz</p> <p>#Res BW 30 kHz #VBW 100 kHz Sweep 3.2 ms (601 pts)</p> <p>Occupied Bandwidth 912.7016 kHz Occ BW % Pwr 99.00 %</p> <p>x dB Bandwidth 1.010 MHz x dB -20.00 dB</p> <p>Transmit Freq Error 8.880 kHz</p> <p>x dB Bandwidth 1.010 MHz</p>		<p>Freq/Channel</p> <p>Center Freq 2.44100000 GHz</p> <p>Start Freq 2.43950000 GHz</p> <p>Stop Freq 2.44250000 GHz</p> <p>CF Step 300.000000 kHz</p> <p>Auto Man</p> <p>Freq Offset 0.00000000 Hz</p> <p>Signal Track On Off</p>
---	--	--

File Operation Status, A:\SCREN603.GIF file saved

Test Frequency: 2480MHz

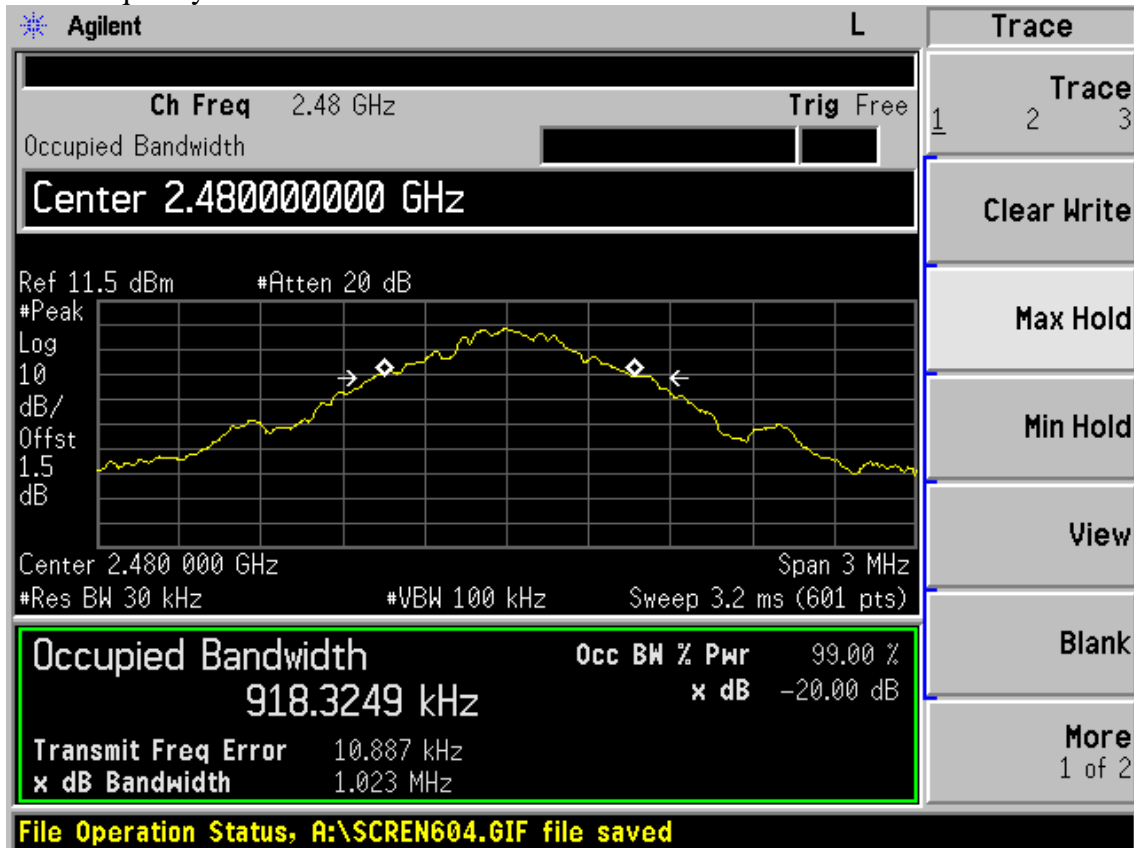

8DPSK

Test Frequency: 2402MHz

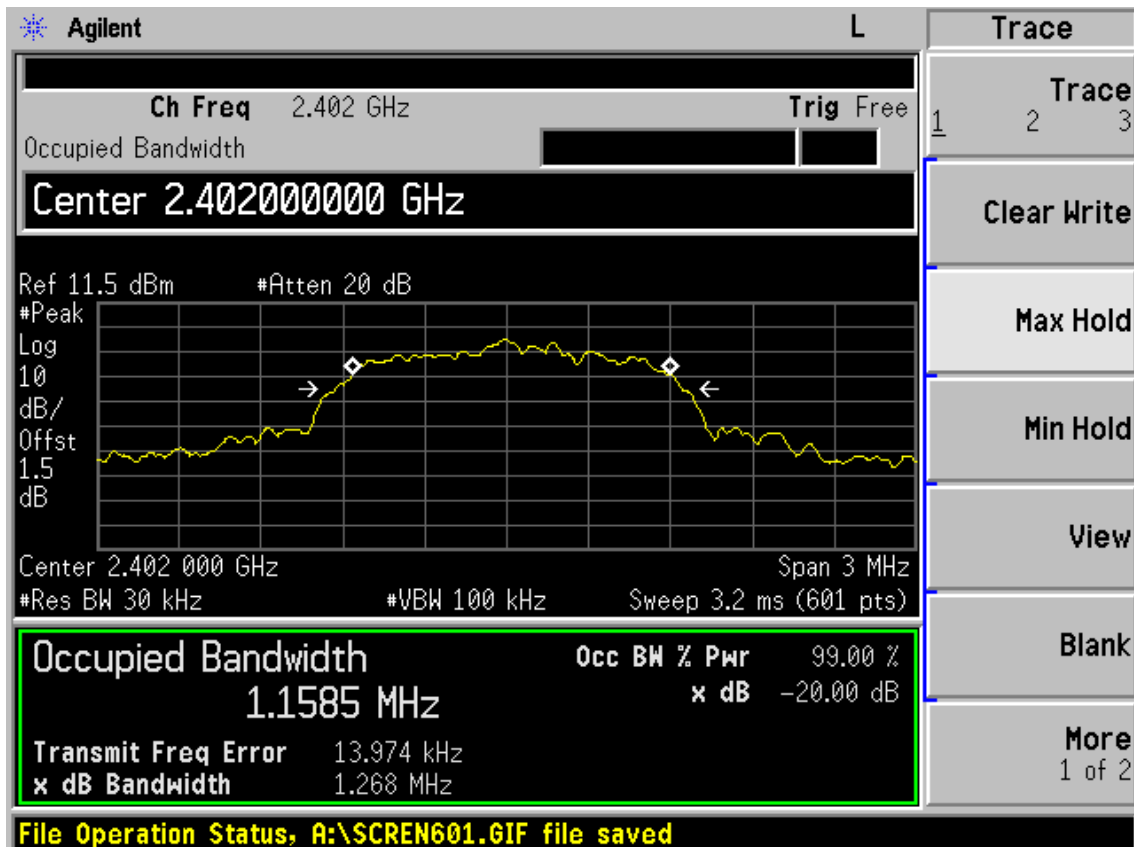

Test Frequency: 2441MHz

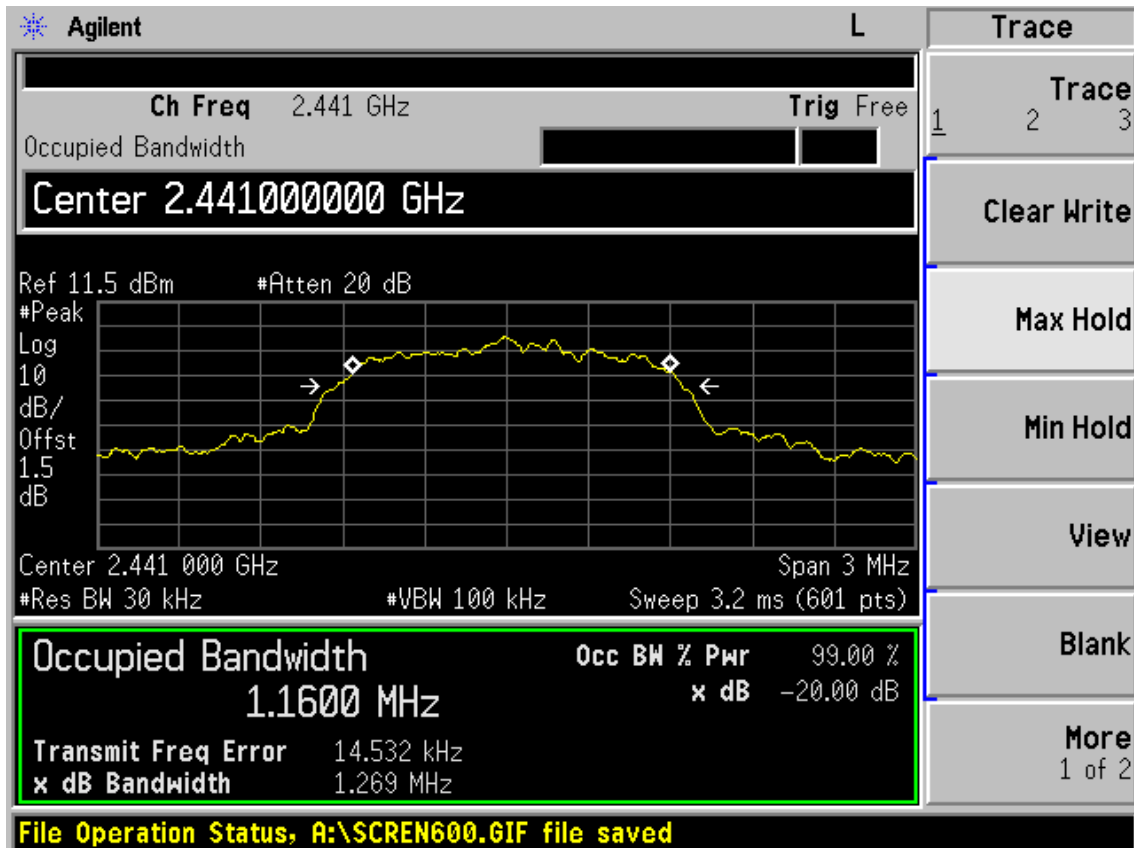

Test Frequency: 2480MHz

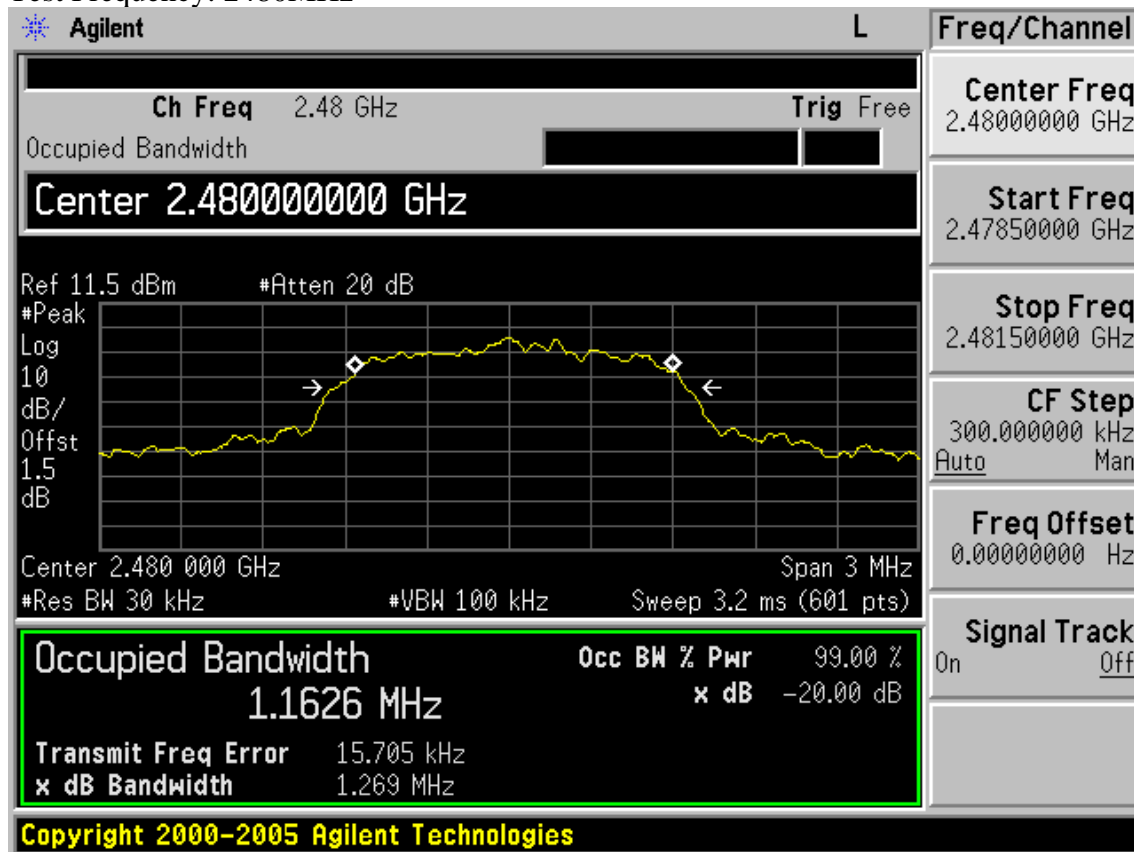

8. NUMBER OF HOPPING FREQUENCY TEST

8.1. Test Equipment

Item	Equipment	Manufacturer	Model No.	Serial No.	Last Cal.	Cal. Interval
1	Spectrum Analyzer	Agilent	E4446A	US44300459	May.08, 11	1 Year

8.2. Limit

Frequency hopping systems in the 2400-2483.5 MHz band shall use at least 15 channels

8.3. Test Results

EUT: Tablet PC		
M/N: T10COT		
Test date:2011-07-28	Pressure:100.6 kpa	Humidity:53%
Tested by:Leo-Li	Test site: RF site	Temperature:25 °C

Number of channel	Limit	Conclusion
79	≥ 15	PASS

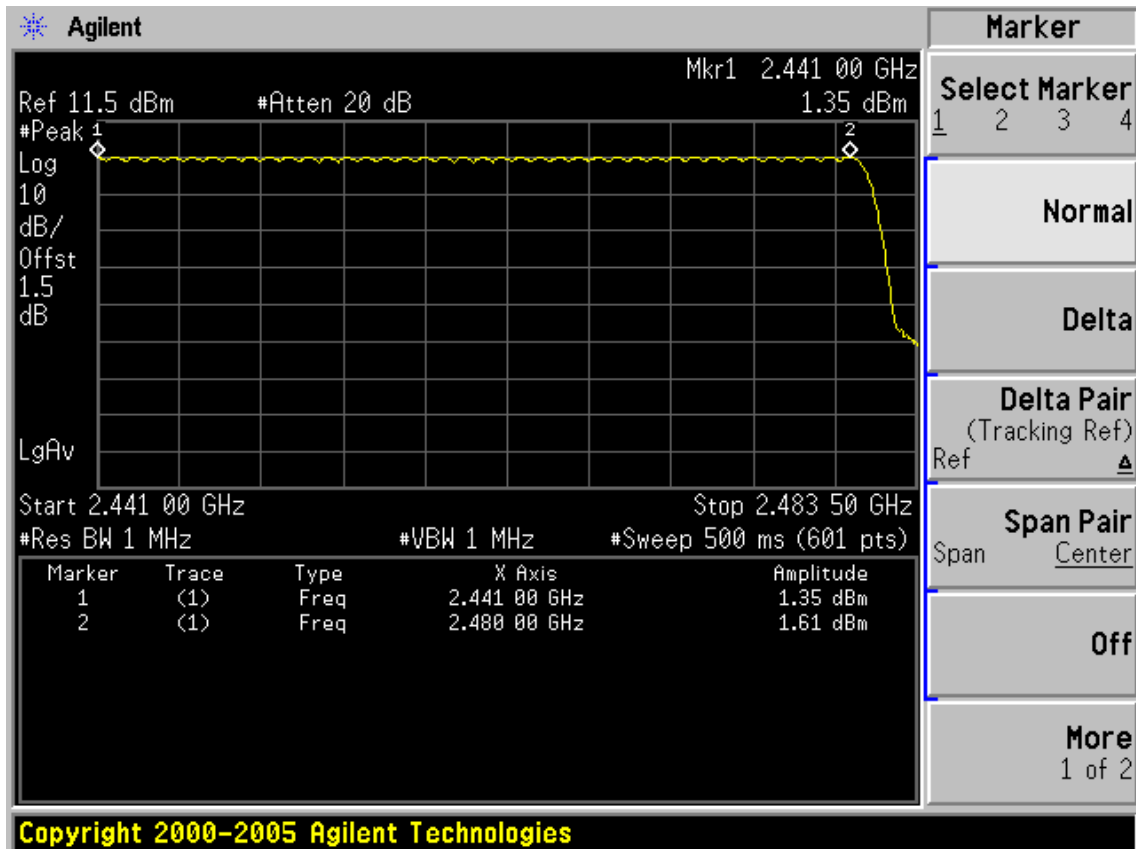
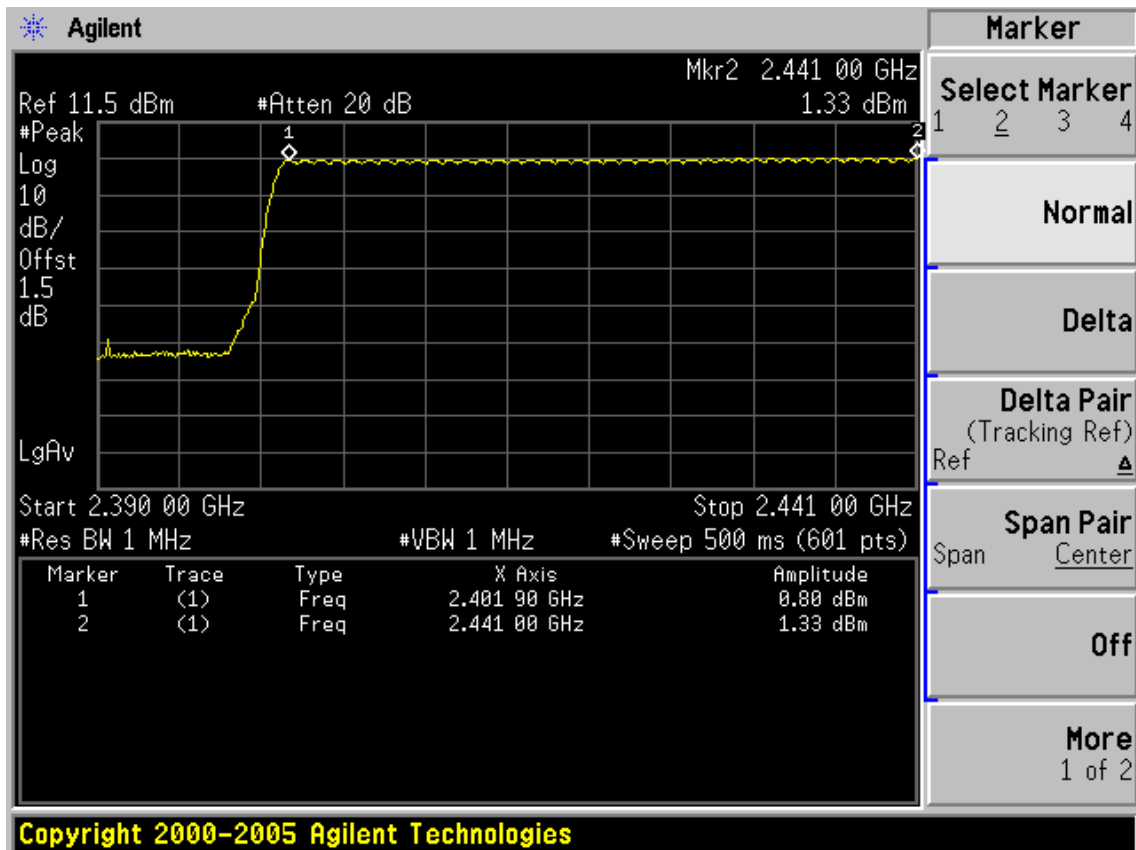

9. DWELL TIME

9.1. Test Equipment

Item	Equipment	Manufacturer	Model No.	Serial No.	Last Cal.	Cal. Interval
1	Spectrum Analyzer	Agilent	E4446A	US44300459	May.08, 11	1 Year

9.2. Limit

The average time of occupancy on any channel shall not be greater than 0.4 seconds within a period of 0.4 seconds multiplied by the number of hopping channels employed.

9.3. Test Results

EUT: Tablet PC		
M/N: T10COT		
Test date: 2011-07-28	Pressure: 100.6 kpa	Humidity: 53%
Tested by: Leo-Li	Test site: RF site	Temperature: 25 °C

Mode	dwell time		Limit	Conclusion
GFSK	DH1	$51\text{hops}/5\text{s} * 0.4 * 79\text{channels} * 0.495\text{ms} = 159.55\text{ms}$	<400ms	PASS
	DH3	$26\text{hops}/5\text{s} * 0.4 * 79\text{channels} * 1.758\text{ms} = 288.87\text{ms}$	<400ms	PASS
	DH5	$19\text{hops}/5\text{s} * 0.4 * 79\text{channels} * 3.017\text{ms} = 362.28\text{ms}$	<400ms	PASS
8DPSK	DH1	$51\text{hops}/5\text{s} * 0.4 * 79\text{channels} * 0.508\text{ms} = 163.74\text{ms}$	<400ms	PASS
	DH3	$26\text{hops}/5\text{s} * 0.4 * 79\text{channels} * 1.75\text{ms} = 287.56\text{ms}$	<400ms	PASS
	DH5	$15\text{hops}/5\text{s} * 0.4 * 79\text{channels} * 3.027\text{ms} = 286.96\text{ms}$	<400ms	PASS

Note: All the lower levels were signal from receiver's, and should not considered in here.

GFSK

DH 1

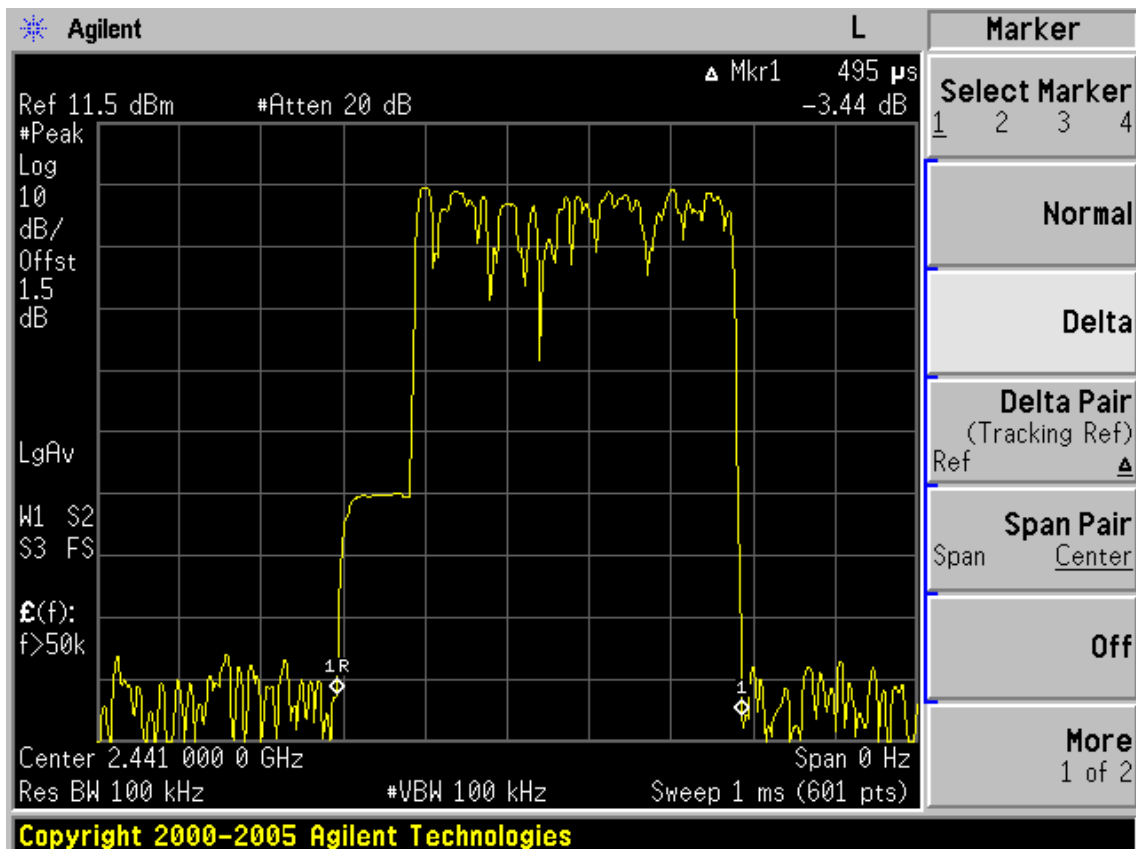
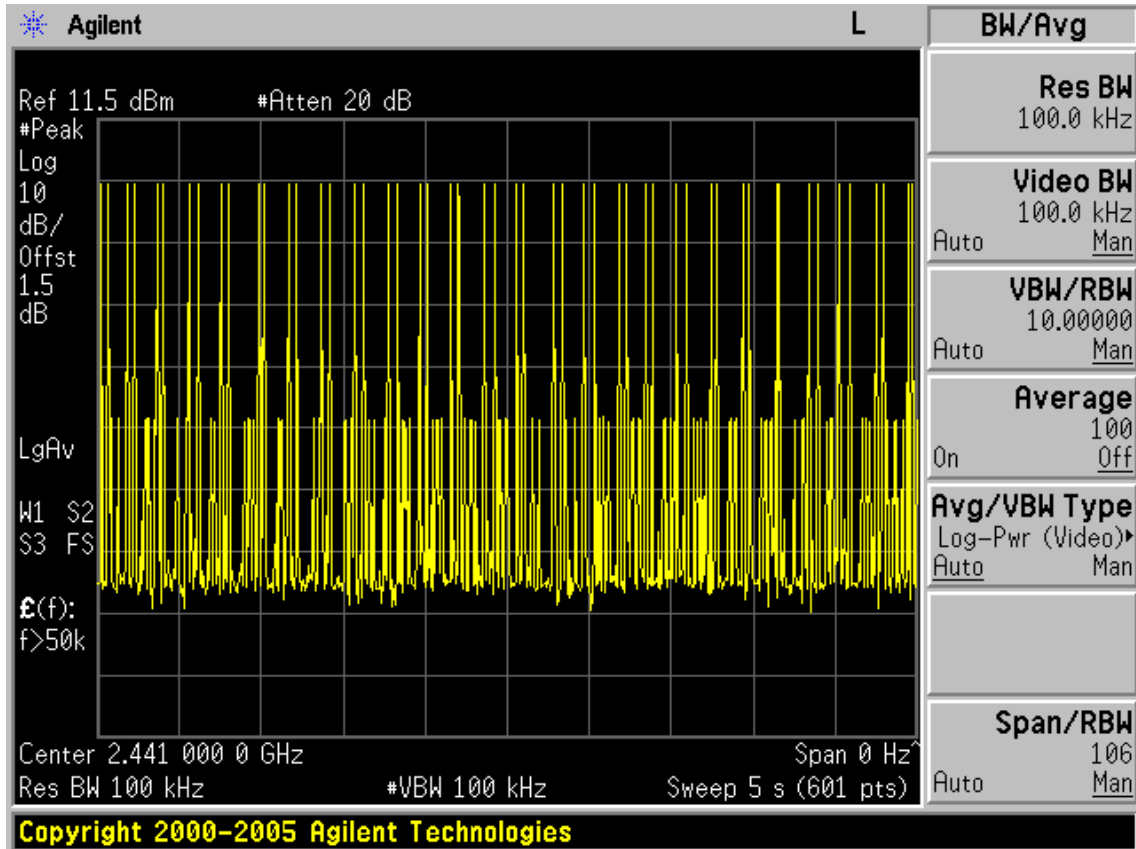

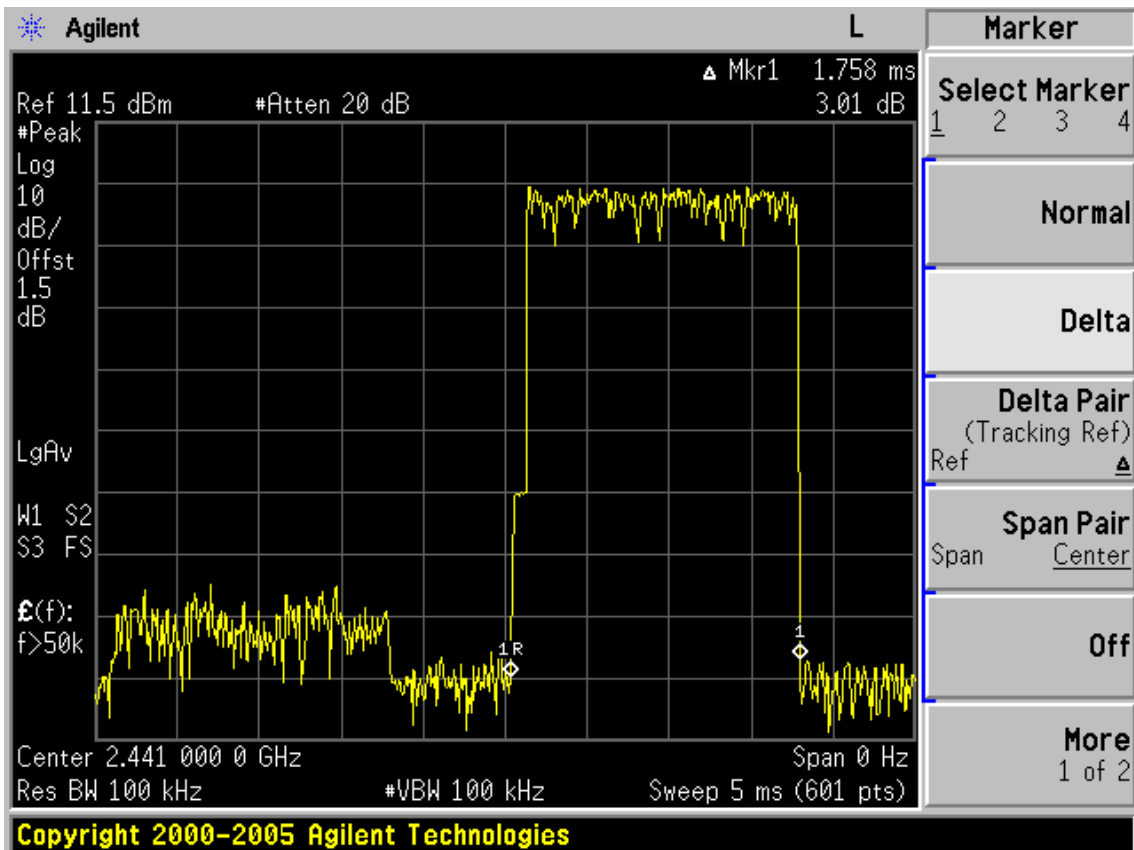
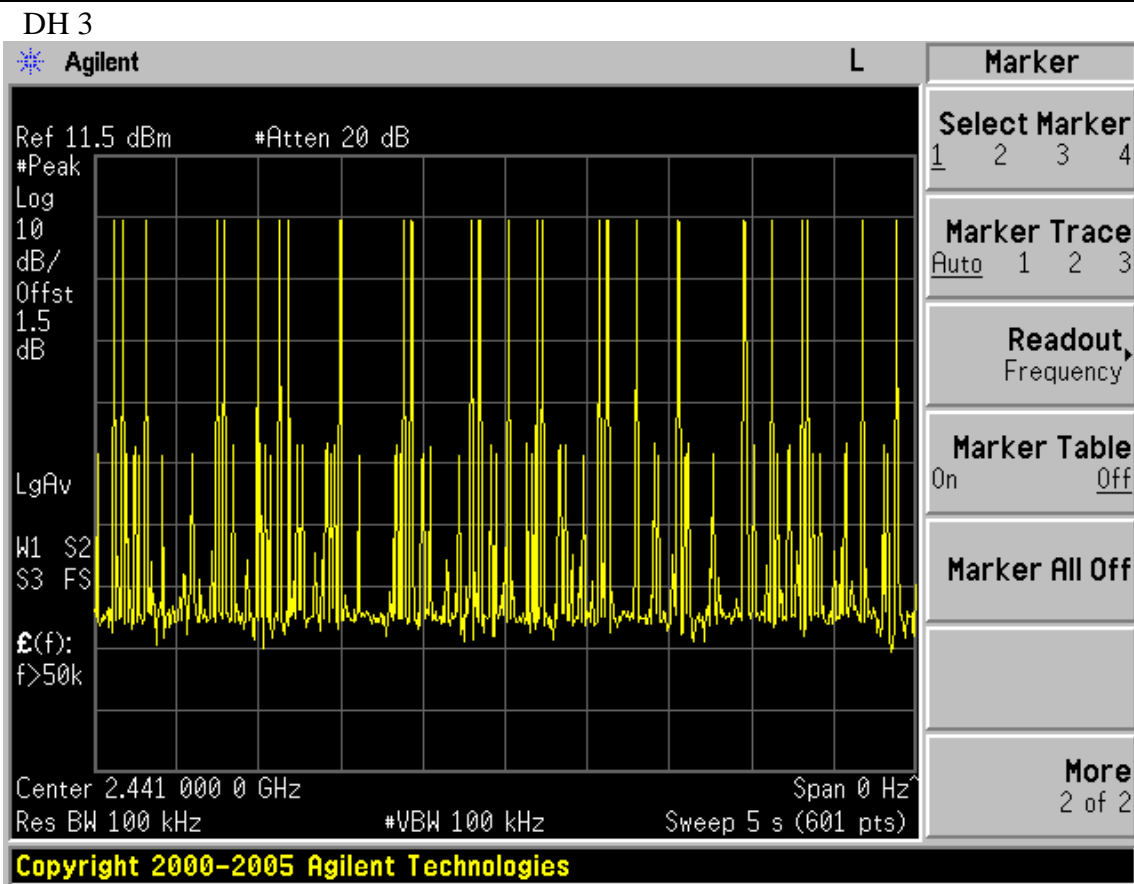

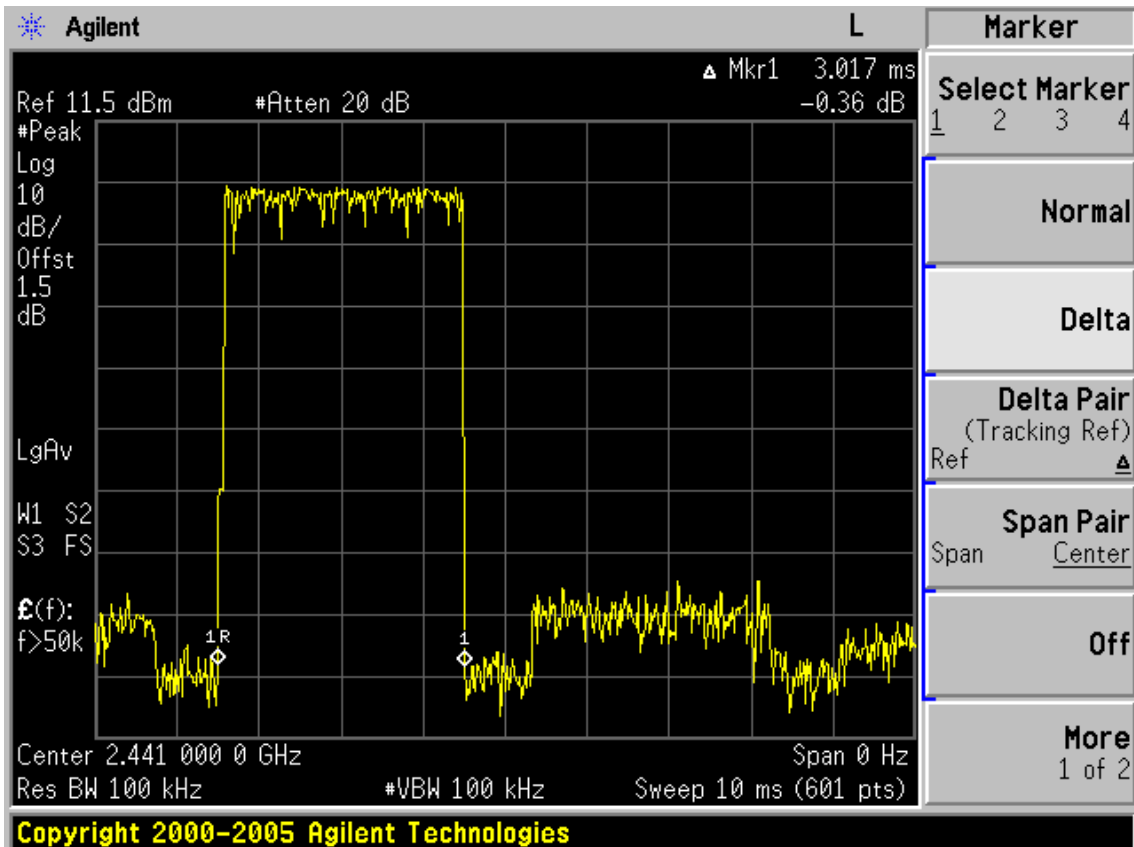
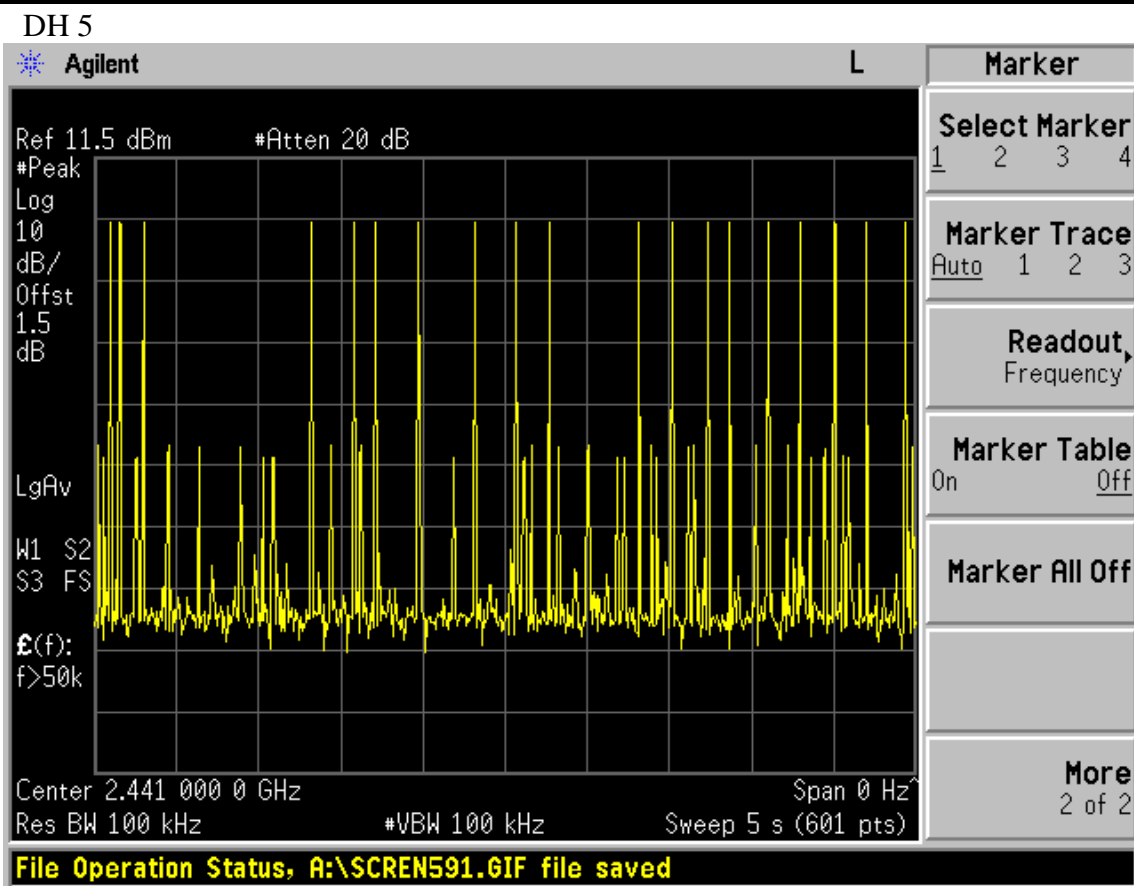

8DPSK

DH 1

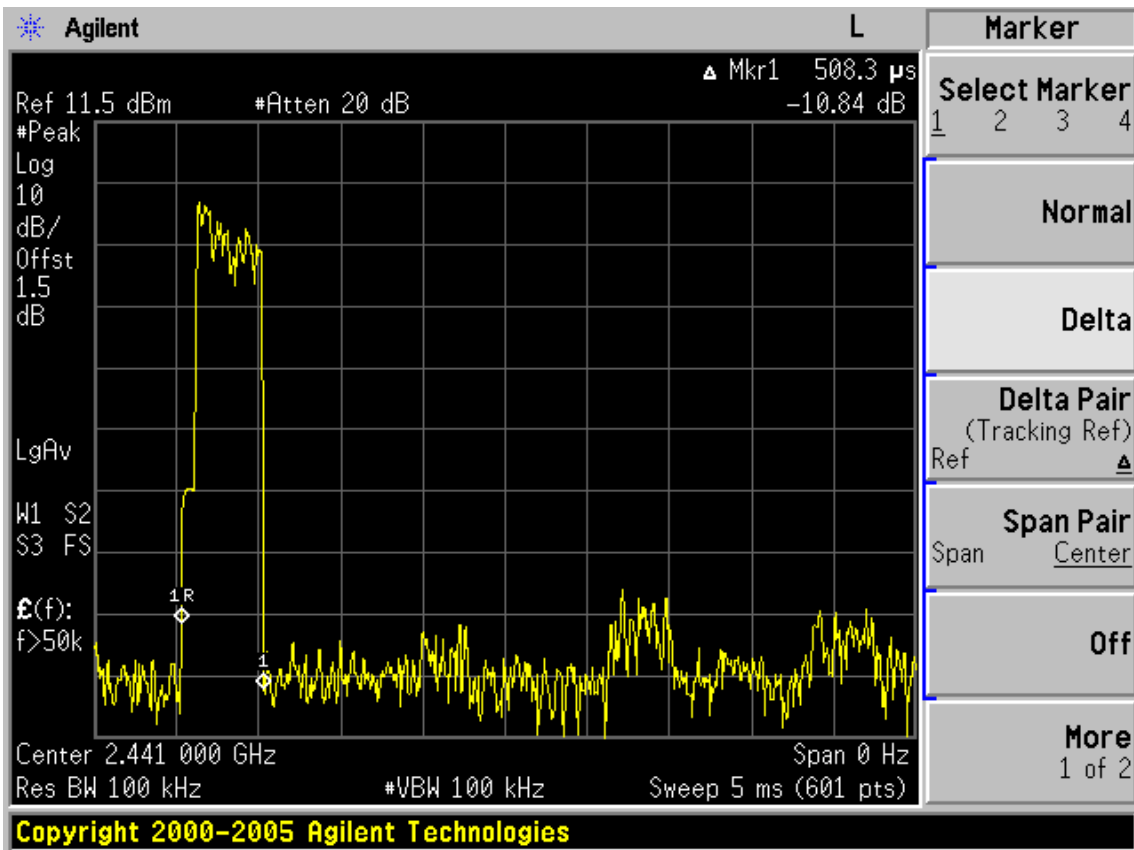
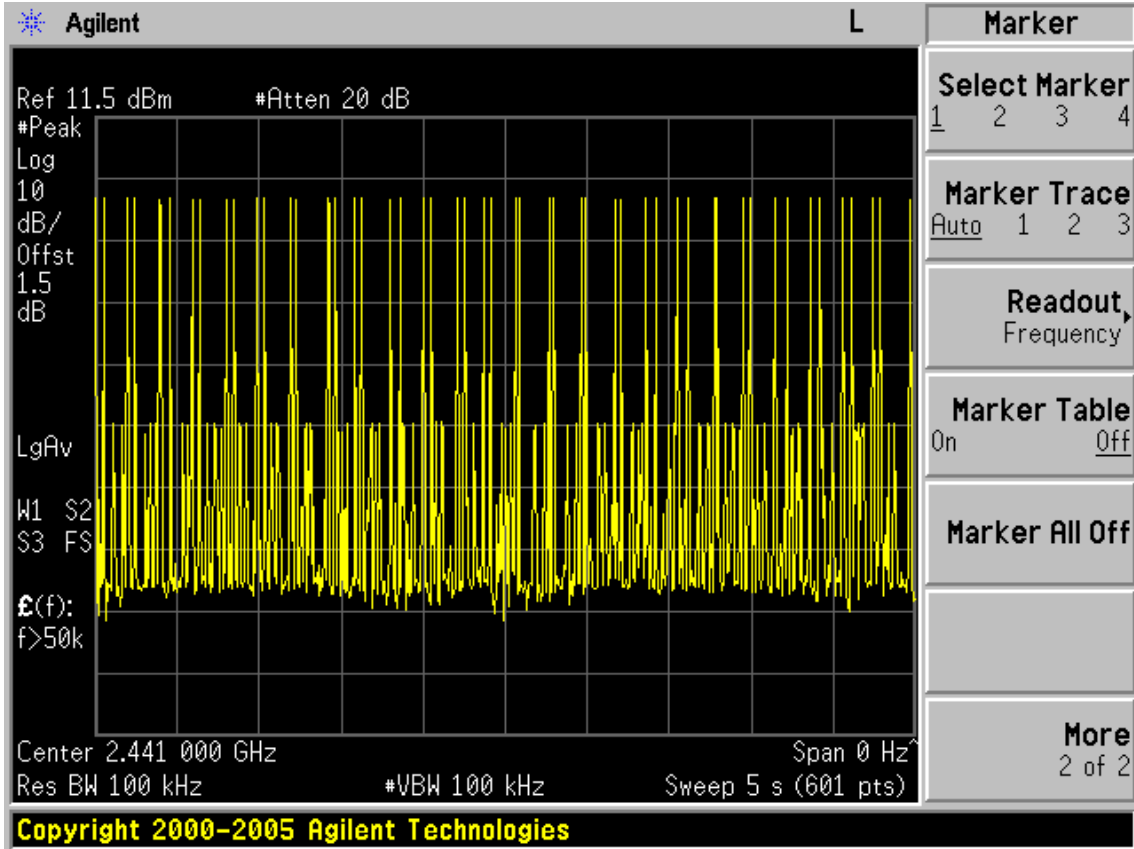

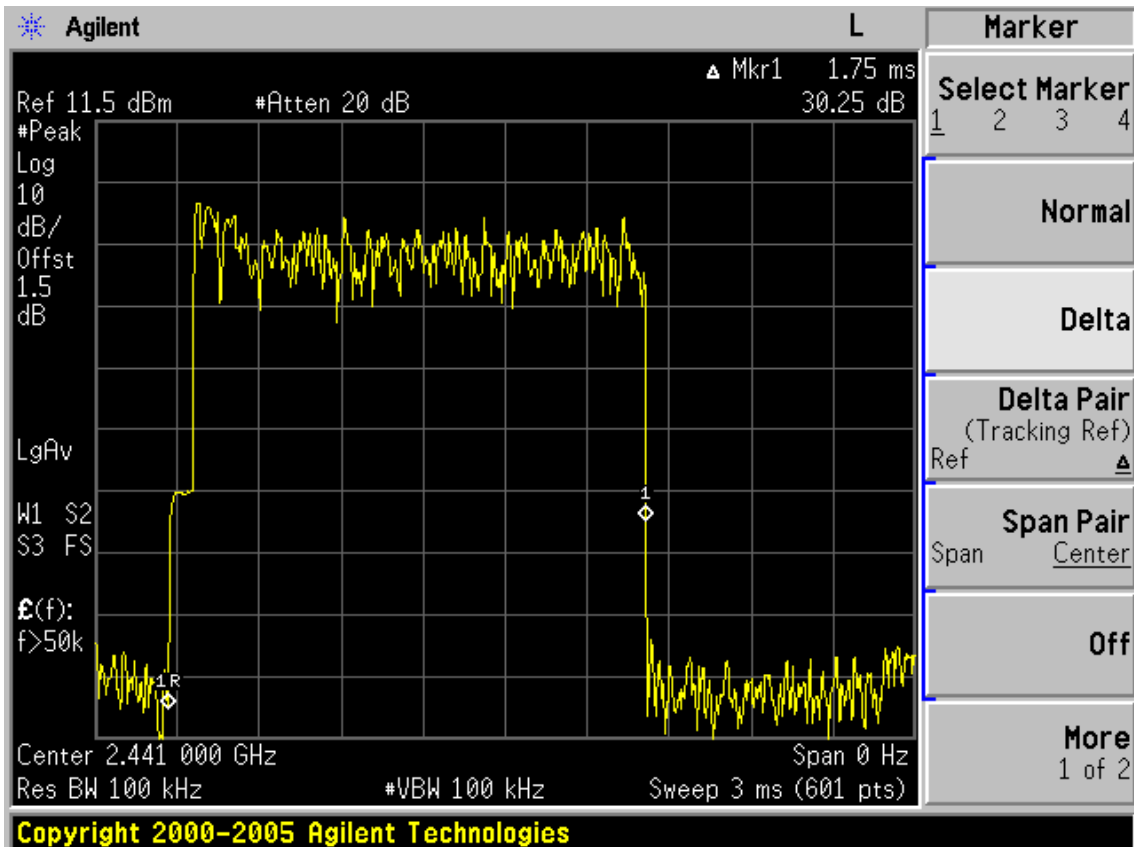
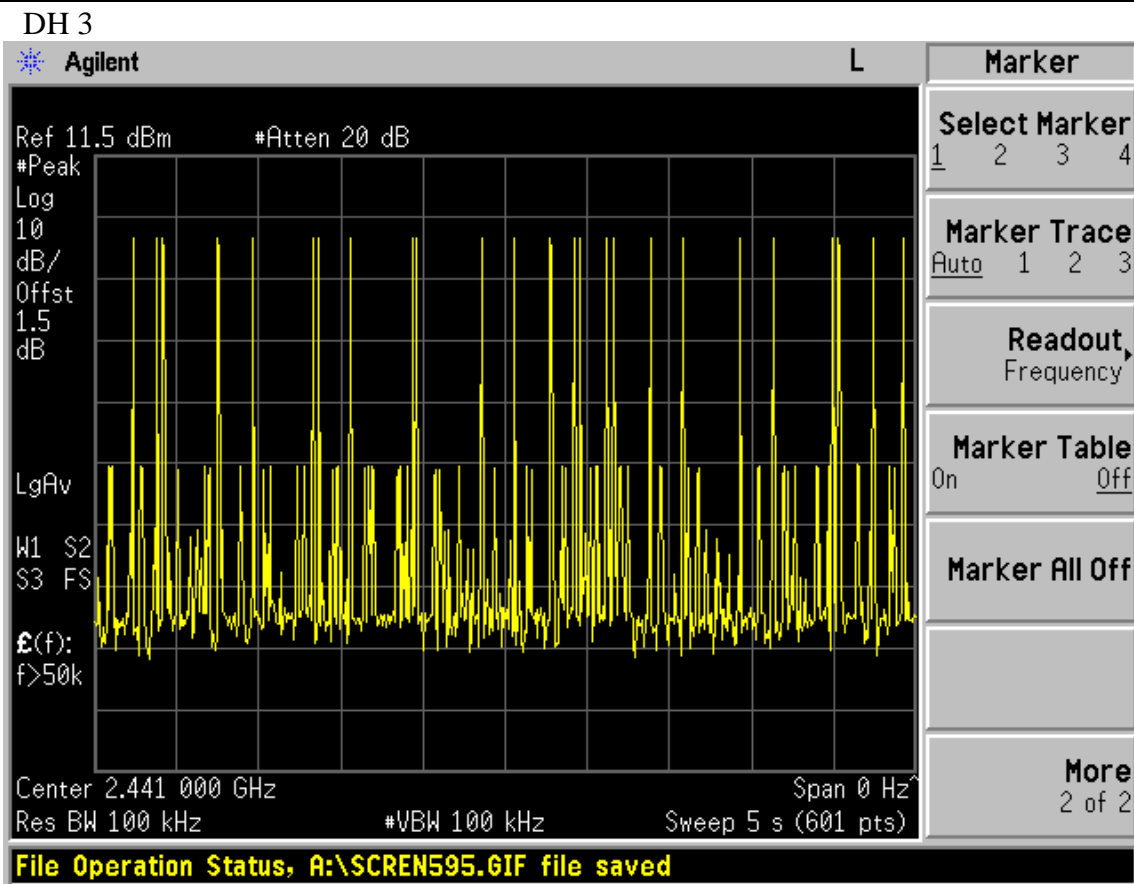

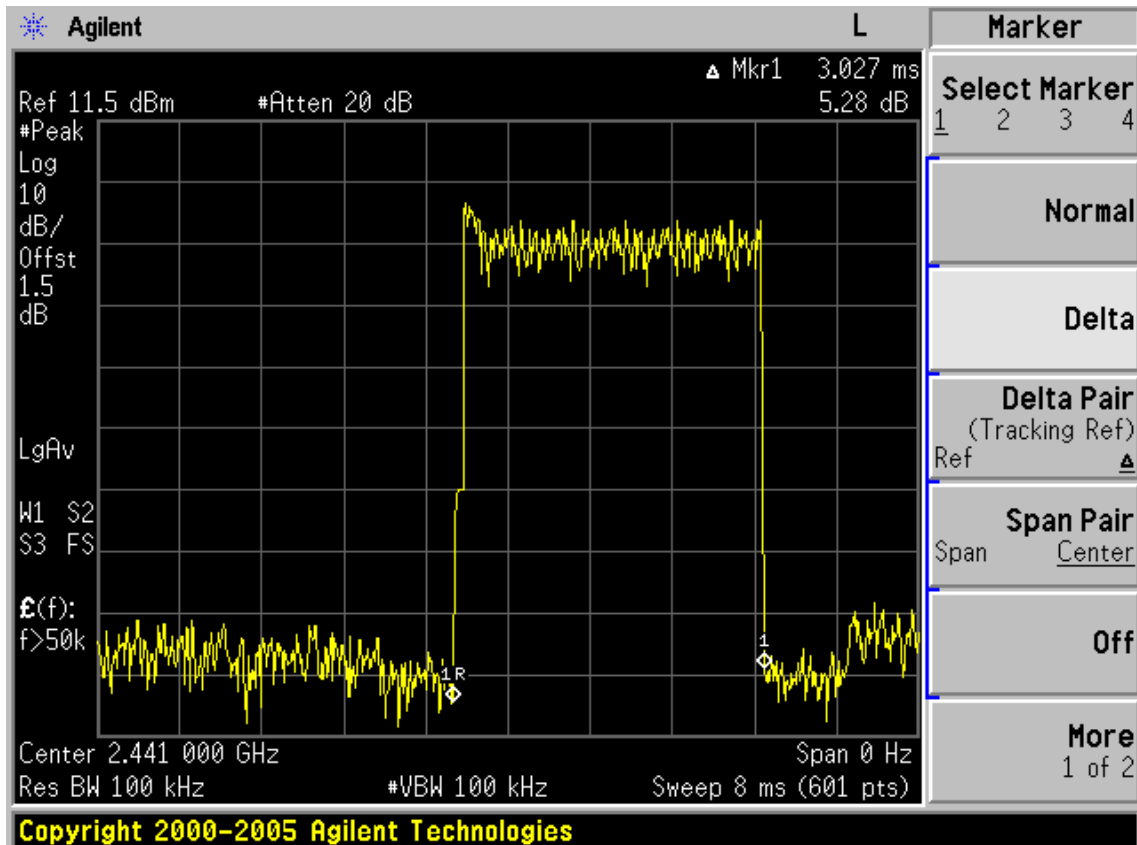
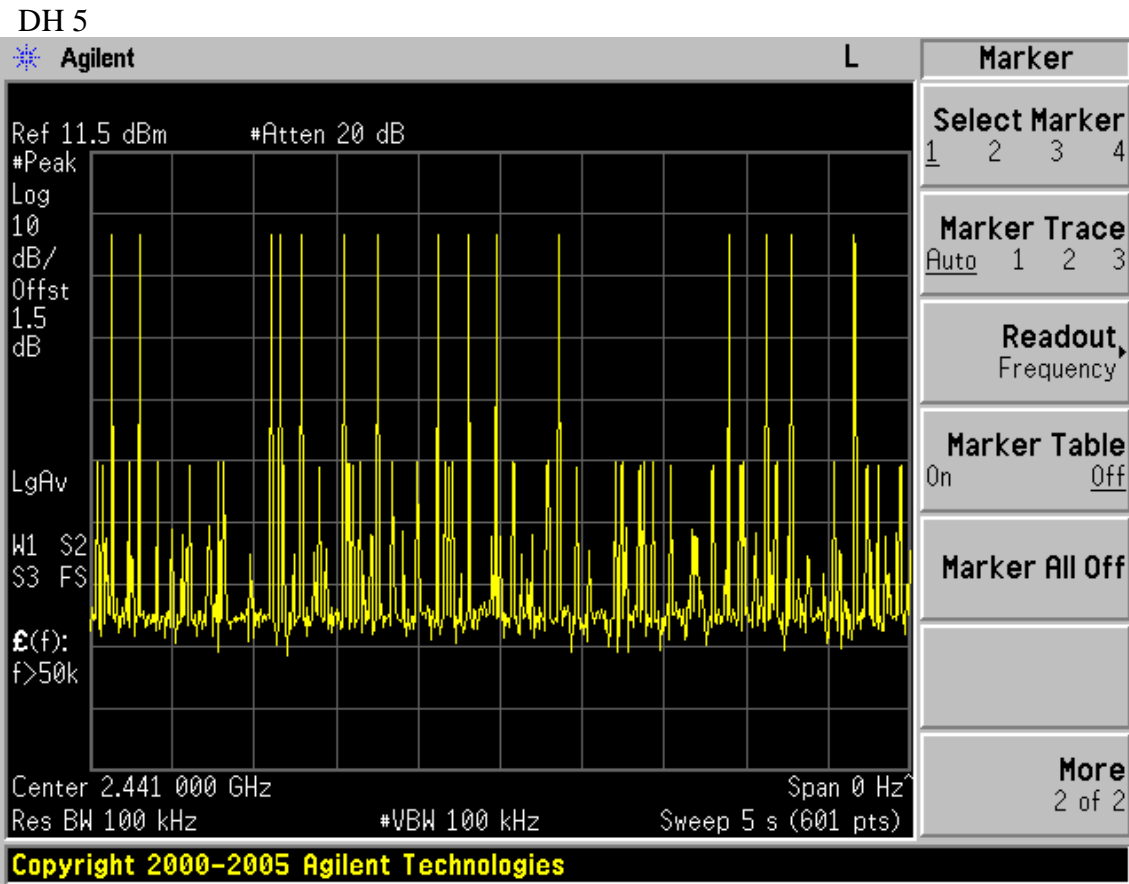

10. MAXIMUM PEAK OUTPUT POWER TEST

10.1. Test Equipment

Item	Equipment	Manufacturer	Model No.	Serial No.	Last Cal.	Cal. Interval
1.	Spectrum Analyzer	Agilent	E4446A	US44300459	May.08, 11	1 Year
2.	Horn Antenna	EMCO	3115	9510-4580	Nov.19, 10	1.5 Year
3.	Horn Antenna	EMCO	3115	9607-4877	Nov. 25, 10	1.5 Year
4.	Signal Generator	HP	83732B	VS34490501	May.08, 11	1 Year
5.	Amplifier	Agilent	8491B	MY39262165	May.08, 11	1 Year
6.	RF Cable	Hubersuhner	SUCOFLEX 102	28620/2	May,08, 11	1 Year
7.	RF Cable	Hubersuhner	SUCOFLEX 102	271471/4	May,08, 11	1 Year
8.	RF Cable	Hubersuhner	SUCOFLEX 102	29086/2	May,08, 11	1 Year
9.	RF Cable	Hubersuhner	SUCOFLEX 102	271473/4	May,08, 11	1 Year
10.	RF Cable	Hubersuhner	SUCOFLEX 102	29091/2	May,08, 11	1 Year

10.2. Limit

For frequency hopping systems operating in the 2400-2483.5 MHz band employing at least 75 non-overlapping hopping channels, and all frequency hopping systems in the 5725-5850 MHz band: 1 watt. For all other frequency hopping systems in the 2400-2483.5 MHz band: 0.125 watts.

10.3. Test Procedure

1. Connected the EUT's antenna port to spectrum analyzer.
2. Set the RBW > Bandwidth of test Frequency and put the test Frequency, Set the Span large enough to capture the entire signal
3. Use a peak detector on max hold
4. Reading the value from the Spectrum analyzer

Note: The cable loss and attenuator loss were offset into measure device as an amplitude offset.

10.4. Test Results

EUT: Tablet PC			
M/N: T10COT			
Test date: 2011-06-29		Pressure: 101.7 kpa	Humidity: 53%
Tested by: Leo-Li		Test site: RF site	Temperature: 24.4 °C
Cable loss: 1.5 dB		Attenuator loss: 20 dB	Antenna Gain: 2.0 dBi
Test Mode	CH (MHz)	Peak output Power (dBm)	Limit (dBm)
8DPSK	2402	0.82	20
	2441	2.11	20
	2480	2.92	20
GFSK	2402	0.99	20
	2441	1.98	20
	2480	2.90	20
Conclusion: PASS			

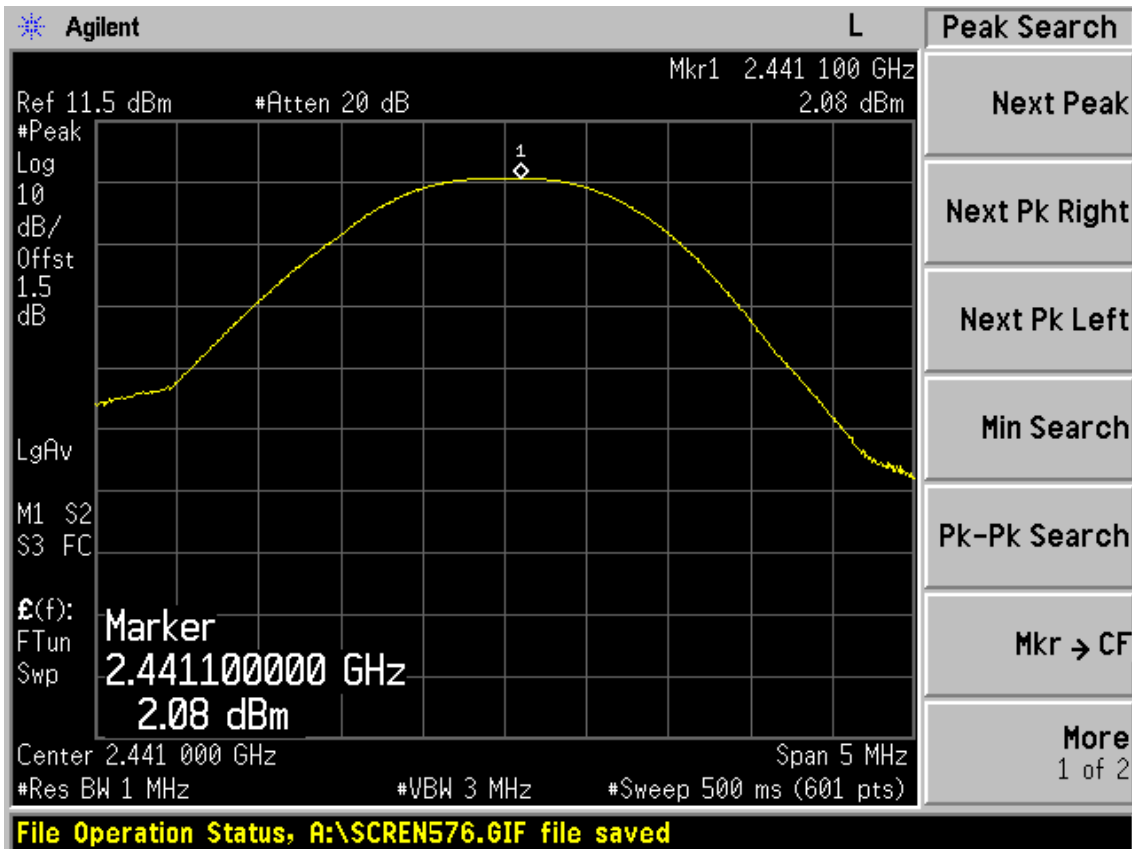
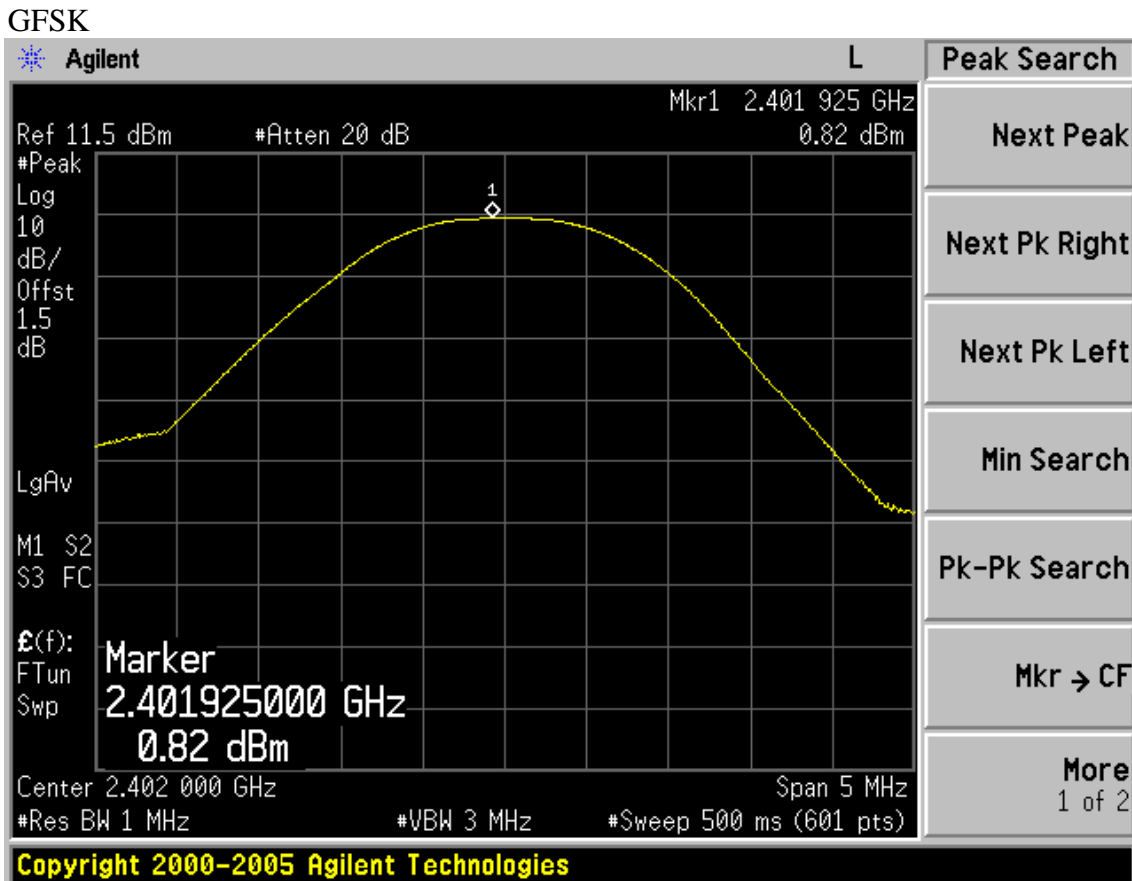

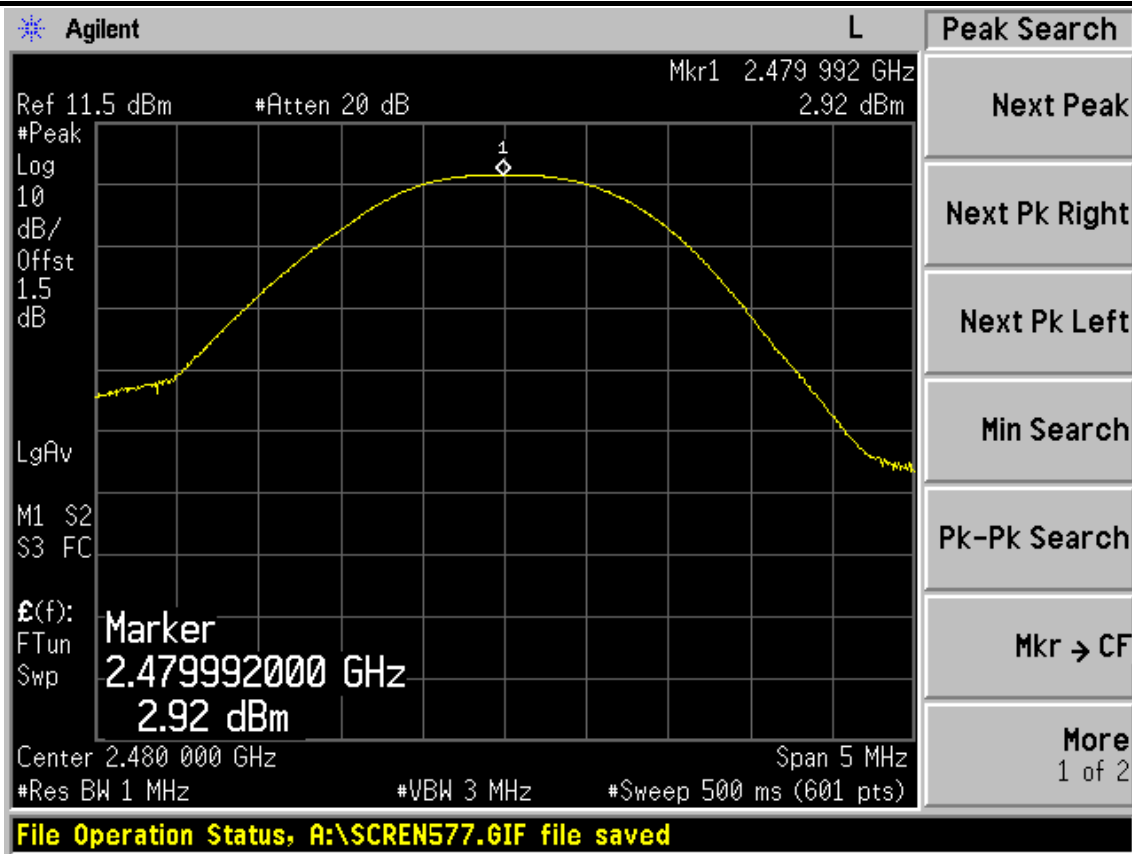

8DPSK

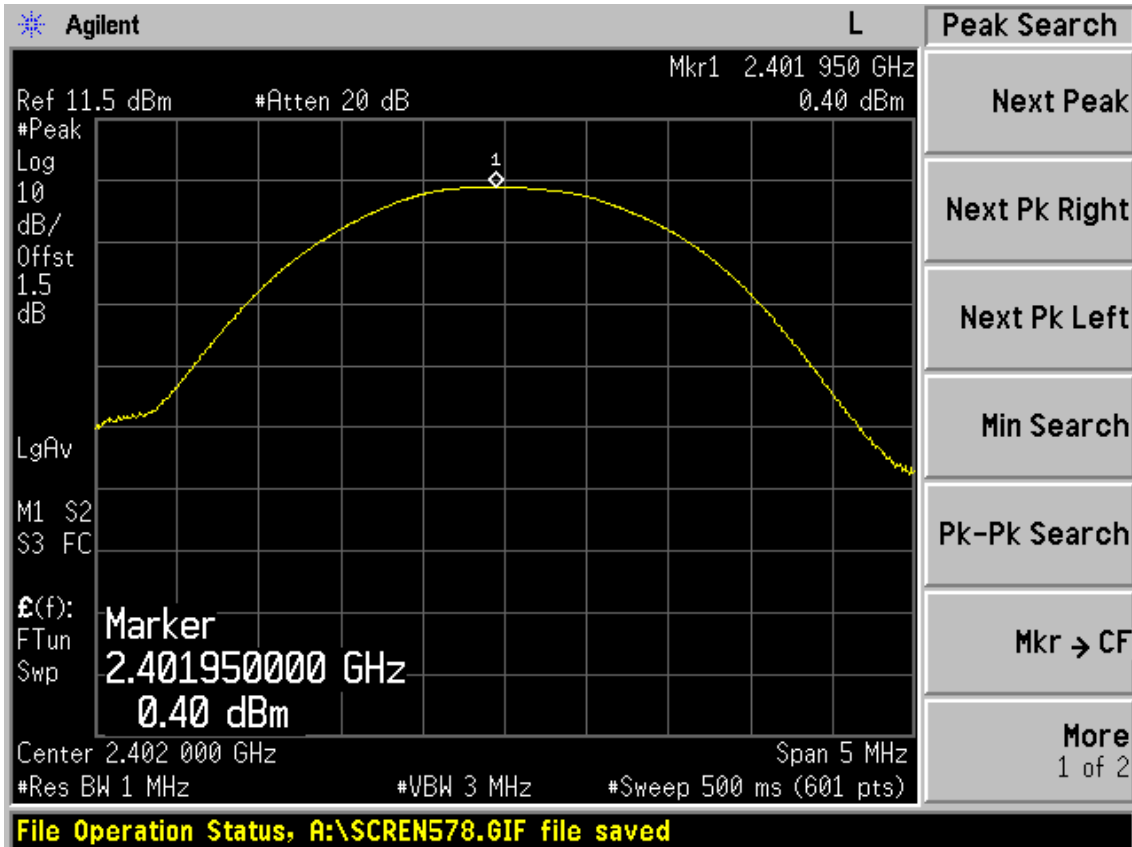

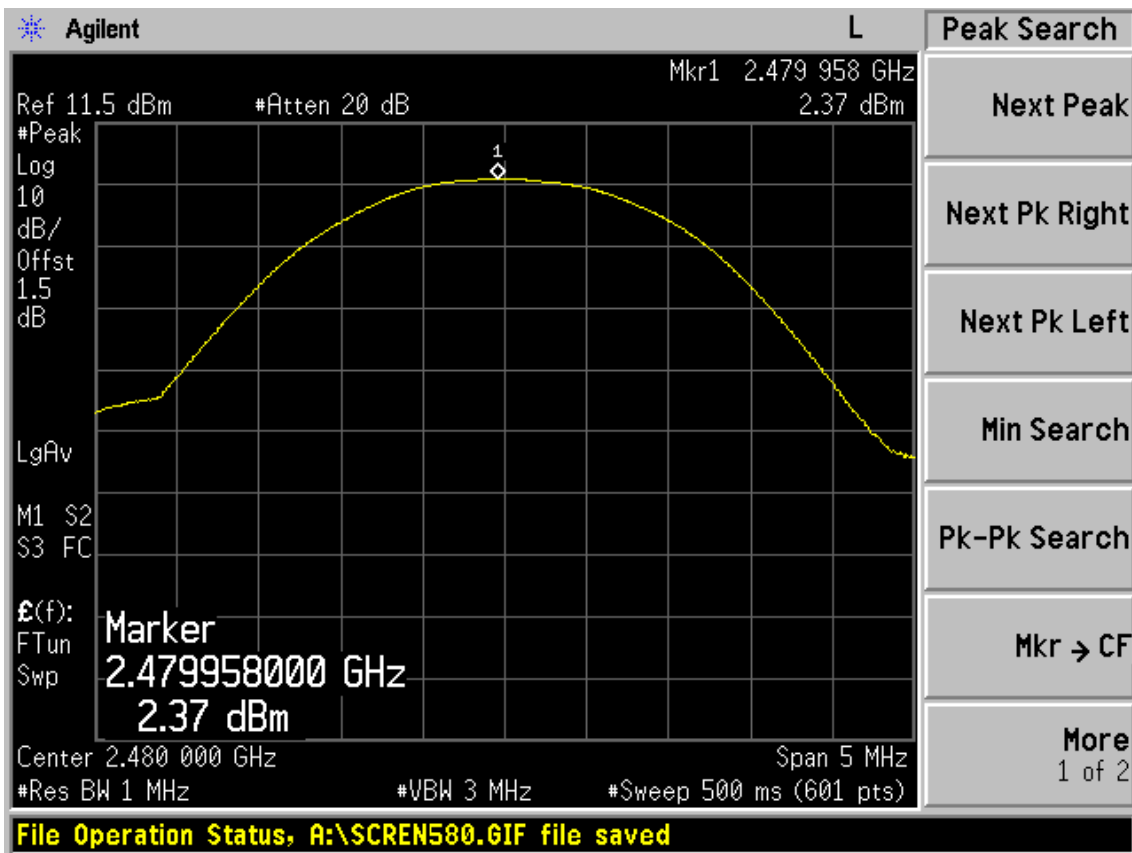
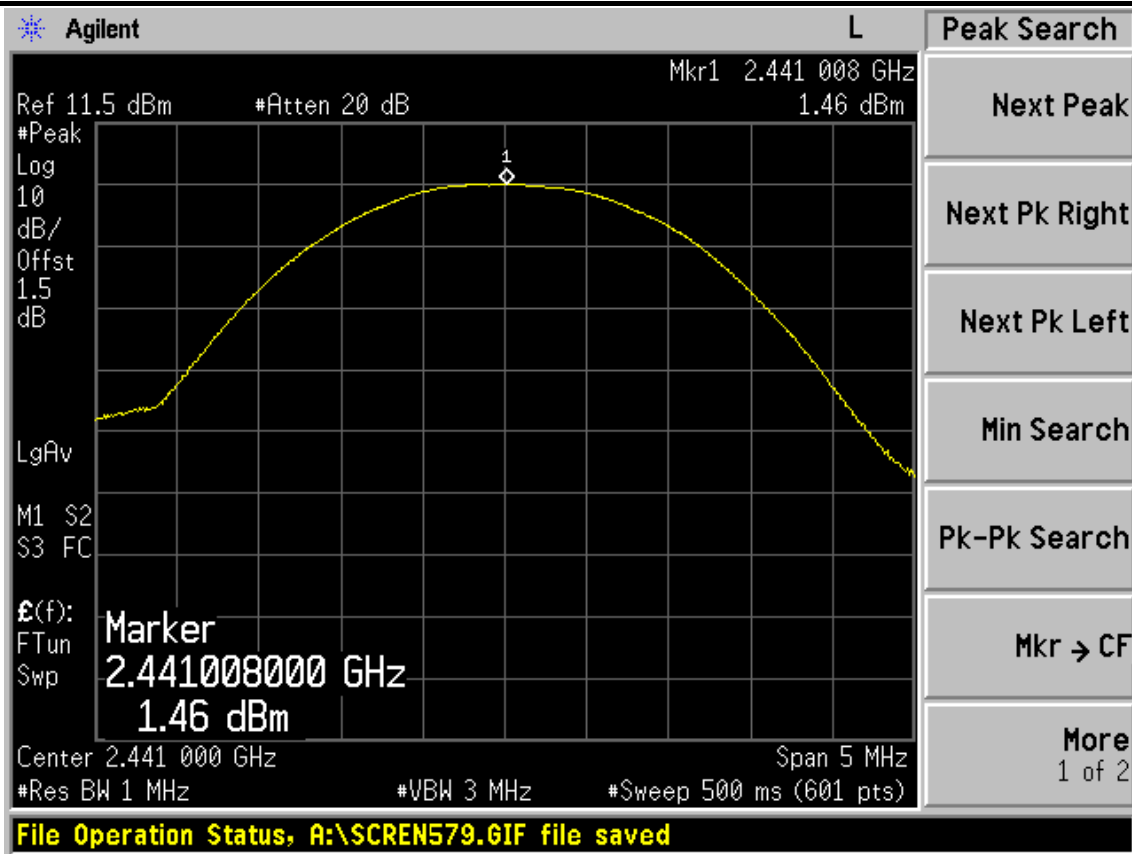

11.BAND EDGE COMPLIANCE TEST

11.1.Test Equipment

Item	Equipment	Manufacturer	Model No.	Serial No.	Last Cal.	Cal. Interval
1.	Spectrum Analyzer	Agilent	E4446A	US44300459	May.08,11	1 Year
2.	Horn Antenna	EMCO	3115	9607-4877	Nov.25, 10	1.5 Year
3.	Amplifier	Agilent	8449B	3008A02495	May.08, 11	1 Year
4.	RF Cable	Hubersuhner	SUCOFLEX102	28620/2	May.08,11	1 Year
5.	RF Cable	Hubersuhner	SUCOFLEX102	28618/2	May.08,11	1 Year
6.	RF Cable	Hubersuhner	SUCOFLEX102	28610/2	May.08,11	1 Year

11.2.Limit

All the lower and upper band-edges emissions appearing within 2310MHz to 2390MHz and 2483.5MHz to 2500MHz restricted frequency bands shall not exceed the limits shown in 15.209, all the other emissions outside operation frequency band 2400MHz to 2483.5MHz shall be at least 20dB below the fundamental emissions, or comply with 15.209 limits.

11.3.Test Produce

For upper band emissions that are up to two bandwidths(2MHz) away (2483.5MHz to 2485.5MHz) from the band-edge use below produce:

1. Choose a spectrum analyzer span that encompasses both the peak of the fundamental emission and the band-edge emission under investigation. Set the analyzer RBW to 100KHz and with a video bandwidth 300KHz. Record the peak levels of the fundamental emission and the relevant band-edge emission, Observe the stored trace and measure the amplitude delta between the peak of the fundamental and the peak of the band-edge emission. This is not a field strength measurement, it is only a relative measurement to determine the amount by which the emission drops at the band edge relative to the highest fundamental emission level.
2. Subtract the delta measured in step (1) from the maximum field strengths measured in clause 4 .The resultant field strengths are then used to determine band-edge compliance as required by Section 15.205

For emissions above two bandwidths away from the band-edge use below produce:

1. The EUT is placed on a turntable, which is 0.8m above the ground plane and worked at highest radiated power.
2. The turntable was rotated for 360 degrees to determine the position of maximum emission level.
3. EUT is set 3m away from the receiving antenna, which is varied from 1m to 4m to find out the highest emission.
4. Set the spectrum analyzer in the following setting in order to capture the lower and upperband-edges of the emission:
 - (a) PEAK: RBW=1MHz ;VBW=3MHz, PK detector, Sweep=AUTO
 - (b)This device is pulse modulated, a duty cycle factor was used to calculate average level based measured peak level

11.4. Test Results

Pass (The testing data was attached in the next pages.)

Note: If the PK measured levels comply with average limit, then the average level were deemed to comply with average limit.

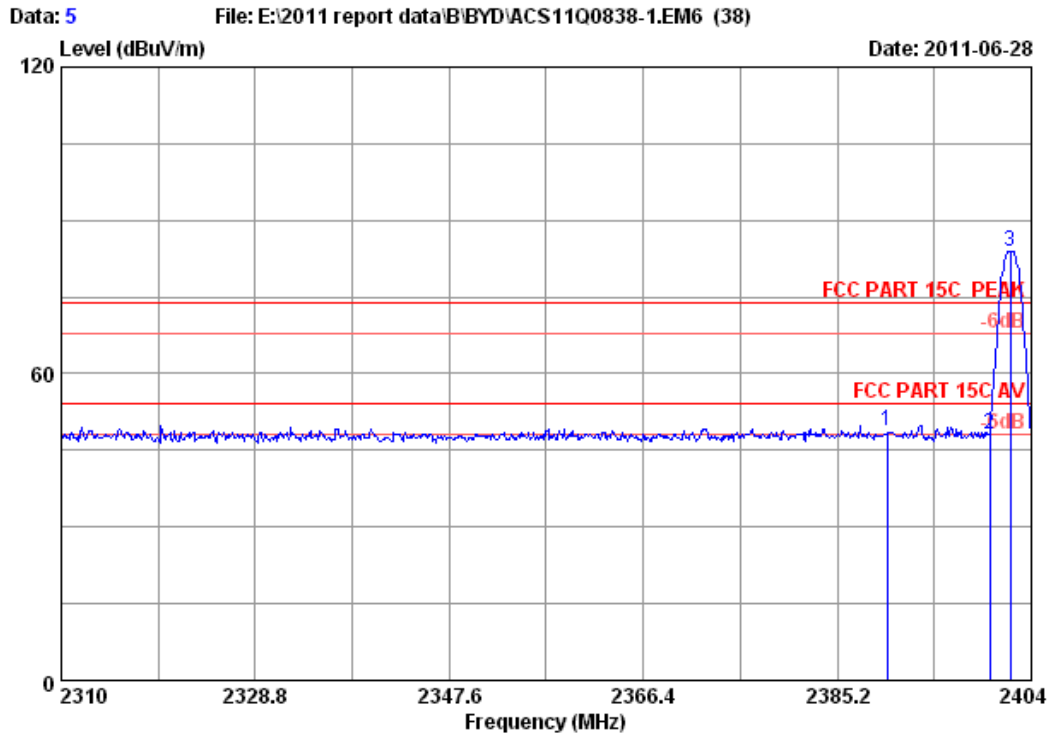

Site no. : 3m Chamber Data no. : 5
 Dis. / Ant. : 3m 2011 3115 4580 Ant. pol. : VERTICAL
 Limit : FCC PART 15C PEAK
 Env. / Ins. : 23°C/54% Engineer : Leo-Li
 EUT : Tablet PC
 Power supply : DC 19V From Adapter input AC 120V/60Hz
 Test mode : GFSK 2402MHz Tx
 M/N : T10COT

	Freq. (MHz)	Ant. Factor (dB/m)	Cable loss (dB)	Amp. Factor (dB)	Reading (dBuV)	Emission Level (dBuV/m)	Limits (dBuV/m)	Margin (dB)	Remark
1	2390.000	27.96	6.72	34.44	48.64	48.88	74.00	25.12	Peak
2	2400.000	27.96	6.75	34.44	48.01	48.28	74.00	25.72	Peak
3	2401.932	27.96	6.75	34.44	83.64	83.91	74.00	-9.91	Peak

Remarks:

1. Emission Level= Antenna Factor + Cable Loss -Amp Factor + Reading.
2. The emission levels that are 20dB below the official limit are not reported.

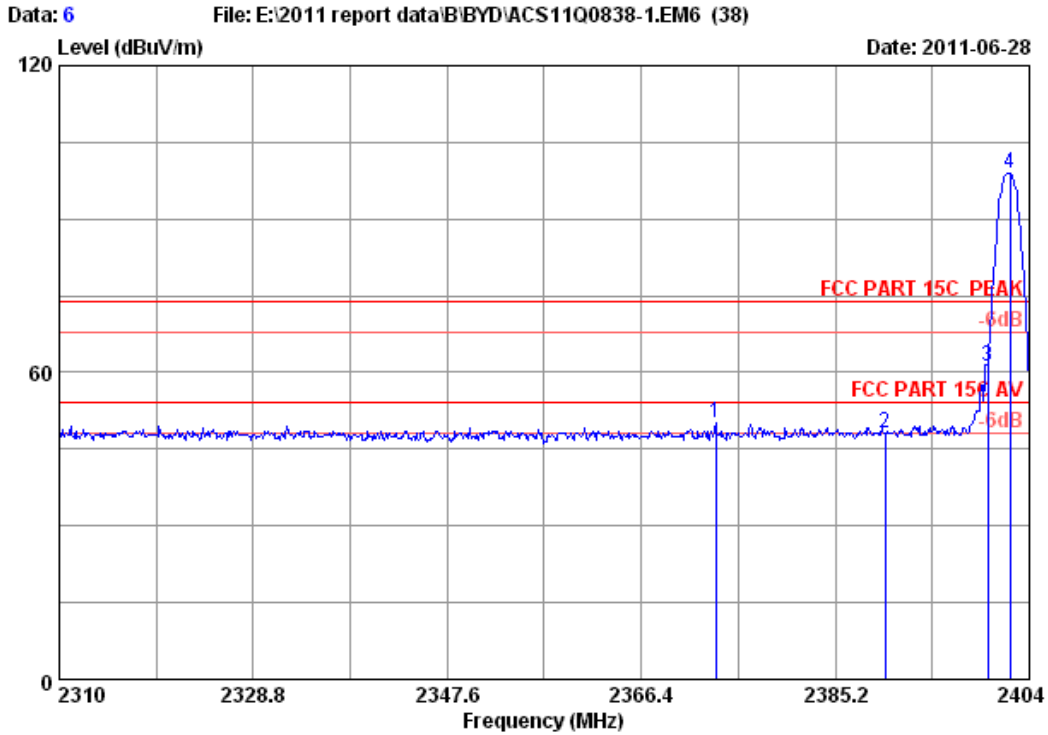

Site no. : 3m Chamber Data no. : 6
 Dis. / Ant. : 3m 2011 3115 4580 Ant. pol. : HORIZONTAL
 Limit : FCC PART 15C PEAK
 Env. / Ins. : 23°C/54% Engineer : Leo-Li
 EUT : Tablet PC
 Power supply : DC 19V From Adapter input AC 120V/60Hz
 Test mode : GFSK 2402MHz Tx
 M/N : T10COT

	Freq. (MHz)	Ant. Factor (dB/m)	Cable loss (dB)	Amp. Factor (dB)	Reading (dBuV)	Emission Level (dBuV/m)	Limits (dBuV/m)	Margin (dB)	Remark
1	2373.638	27.93	6.69	34.44	50.02	50.20	74.00	23.80	Peak
2	2390.000	27.96	6.72	34.44	47.74	47.98	74.00	26.02	Peak
3	2400.000	27.96	6.75	34.44	60.89	61.16	74.00	12.84	Peak
4	2402.120	27.96	6.75	34.44	98.66	98.93	74.00	-24.93	Peak

Remarks:

1. Emission Level= Antenna Factor + Cable Loss -Amp Factor + Reading.
2. The emission levels that are 20dB below the official limit are not reported.

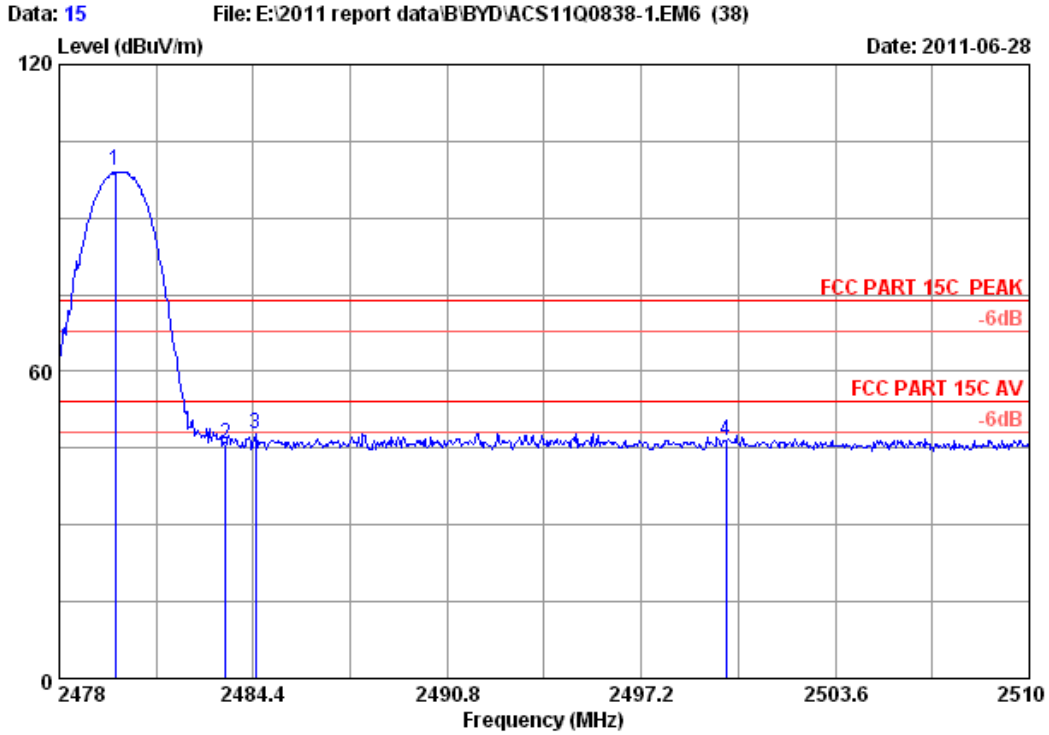

Site no. : 3m Chamber Data no. : 15
 Dis. / Ant. : 3m 2011 3115 4580 Ant. pol. : HORIZONTAL
 Limit : FCC PART 15C PEAK
 Env. / Ins. : 23°C/54% Engineer : Leo-Li
 EUT : Tablet PC
 Power supply : DC 19V From Adapter input AC 120V/60Hz
 Test mode : GFSK 2480MHz Tx
 M/N : T10COT

	Freq. (MHz)	Ant. Factor (dB/m)	Cable loss (dB)	Amp. Factor (dB)	Reading (dBuV)	Emission Level (dBuV/m)	Limits (dBuV/m)	Margin (dB)	Remark
1	2479.856	28.08	6.87	34.45	98.86	99.36	74.00	-25.36	Peak
2	2483.500	28.08	6.90	34.45	45.40	45.93	74.00	28.07	Peak
3	2484.464	28.08	6.90	34.45	47.41	47.94	74.00	26.06	Peak
4	2500.000	28.10	6.90	34.45	45.83	46.38	74.00	27.62	Peak

Remarks:

1. Emission Level= Antenna Factor + Cable Loss -Amp Factor + Reading.
2. The emission levels that are 20dB below the official limit are not reported.

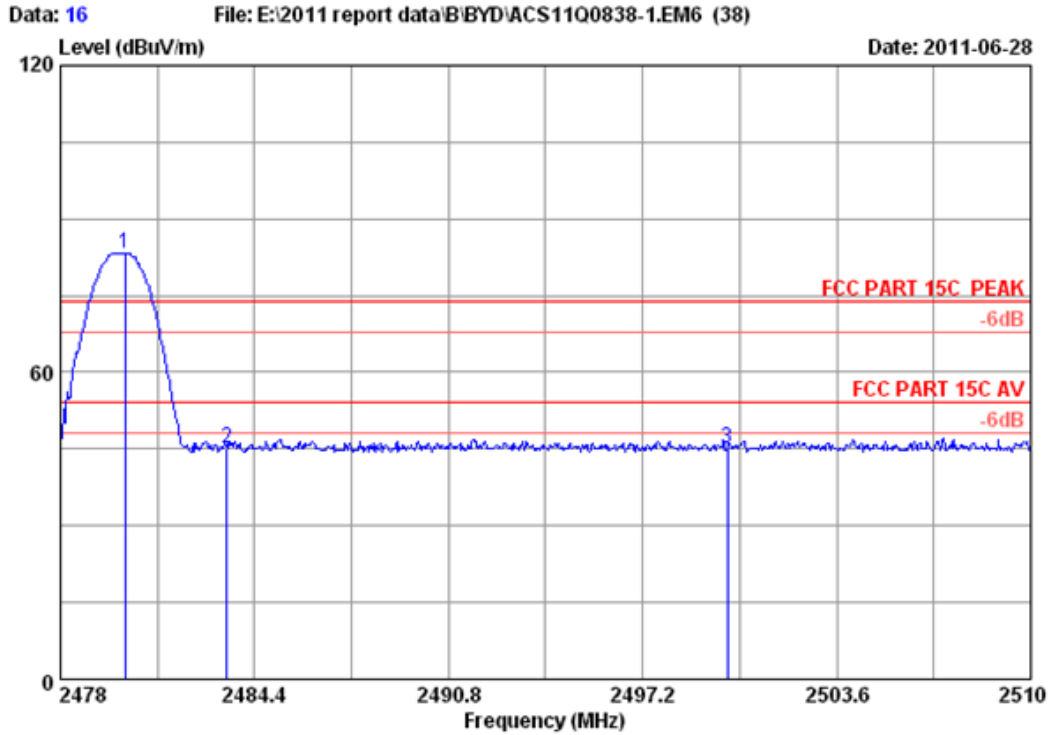

Site no. : 3m Chamber Data no. : 16
 Dis. / Ant. : 3m 2011 3115 4580 Ant. pol. : VERTICAL
 Limit : FCC PART 15C PEAK
 Env. / Ins. : 23°C/54% Engineer : Leo-Li
 EUT : Tablet PC
 Power supply : DC 19V From Adapter input AC 120V/60Hz
 Test mode : GFSK 2480MHz Tx
 M/N : T10COT

	Freq. (MHz)	Ant. Factor (dB/m)	Cable loss (dB)	Amp. Factor (dB)	Reading (dBuV)	Emission Level (dBuV/m)	Limits (dBuV/m)	Margin (dB)	Remark
1	2480.144	28.08	6.87	34.45	82.84	83.34	74.00	-9.34	Peak
2	2483.500	28.08	6.90	34.45	44.66	45.19	74.00	28.81	Peak
3	2500.000	28.10	6.90	34.45	44.53	45.08	74.00	28.92	Peak

Remarks:

1. Emission Level= Antenna Factor + Cable Loss -Amp Factor + Reading.
2. The emission levels that are 20dB below the official limit are not reported.

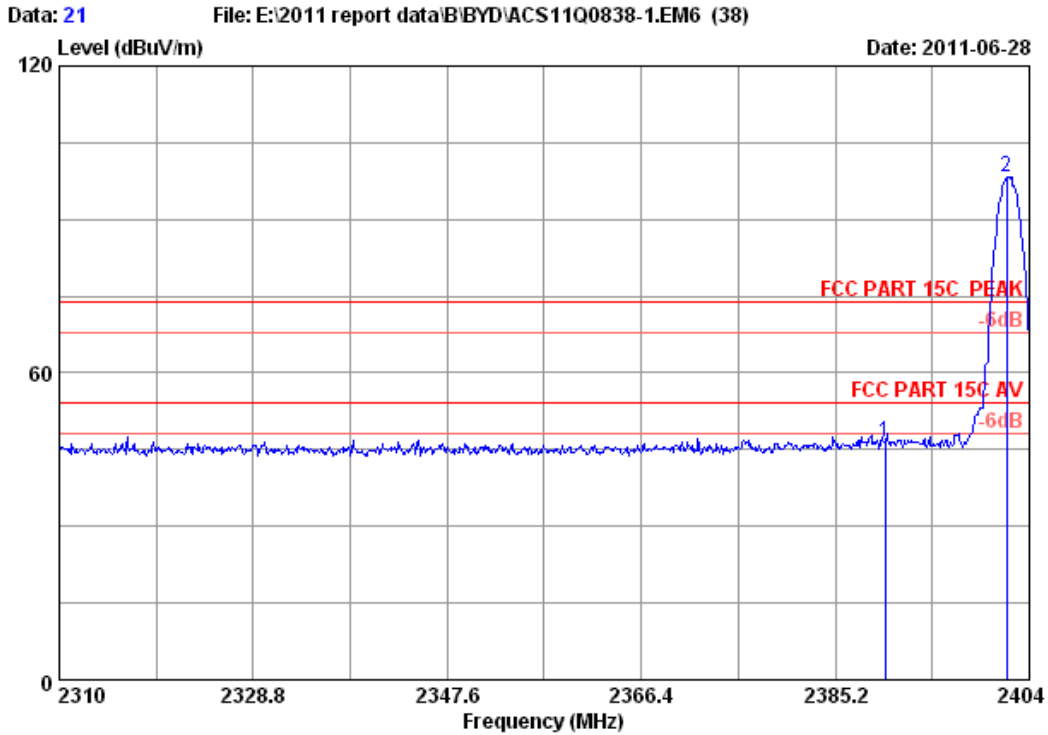

Site no. : 3m Chamber Data no. : 21
 Dis. / Ant. : 3m 2011 3115 4580 Ant. pol. : HORIZONTAL
 Limit : FCC PART 15C PEAK
 Env. / Ins. : 23°C/54% Engineer : Leo-Li
 EUT : Tablet PC
 Power supply : DC 19V From Adapter input AC 120V/60Hz
 Test mode : 8DPSK 2402MHz Tx
 M/N : T10COT

	Freq. (MHz)	Ant. Factor (dB/m)	Cable loss (dB)	Amp. Factor (dB)	Reading (dBuV)	Emission Level (dBuV/m)	Limits (dBuV/m)	Margin (dB)	Remark
1	2390.000	27.96	6.72	34.44	46.06	46.30	74.00	27.70	Peak
2	2401.838	27.96	6.75	34.44	98.09	98.36	74.00	-24.36	Peak

Remarks:

1. Emission Level= Antenna Factor + Cable Loss -Amp Factor + Reading.
2. The emission levels that are 20dB below the official limit are not reported.

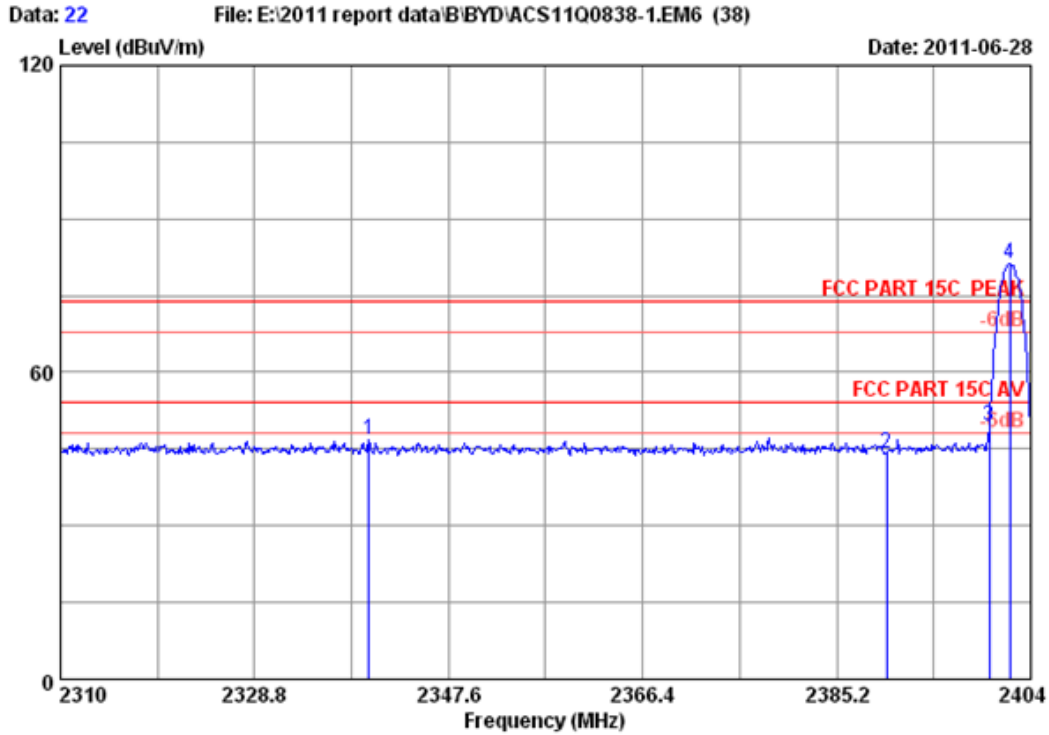

Site no. : 3m Chamber Data no. : 22
 Dis. / Ant. : 3m 2011 3115 4580 Ant. pol. : VERTICAL
 Limit : FCC PART 15C PEAK
 Env. / Ins. : 23°C/54% Engineer : Leo-Li
 EUT : Tablet PC
 Power supply : DC 19V From Adapter input AC 120V/60Hz
 Test mode : 8DPSK 2402MHz Tx
 M/N : T10COT

	Freq. (MHz)	Ant. Factor (dB/m)	Cable loss (dB)	Amp. Factor (dB)	Reading (dBuV)	Emission Level (dBuV/m)	Limits (dBuV/m)	Margin (dB)	Remark
1	2339.892	27.88	6.65	34.44	46.62	46.71	74.00	27.29	Peak
2	2390.000	27.96	6.72	34.44	43.97	44.21	74.00	29.79	Peak
3	2400.000	27.96	6.75	34.44	49.26	49.53	74.00	24.47	Peak
4	2401.932	27.96	6.75	34.44	81.08	81.35	74.00	-7.35	Peak

Remarks:

1. Emission Level= Antenna Factor + Cable Loss -Amp Factor + Reading.
2. The emission levels that are 20dB below the official limit are not reported.

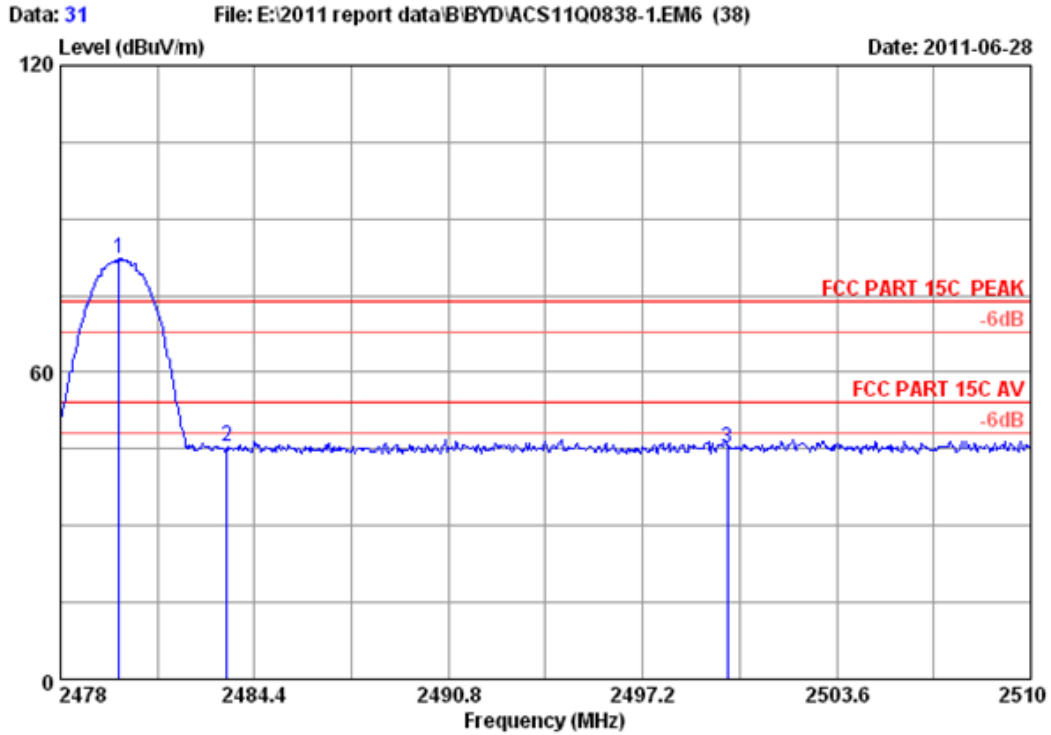

Site no. : 3m Chamber Data no. : 31
 Dis. / Ant. : 3m 2011 3115 4580 Ant. pol. : VERTICAL
 Limit : FCC PART 15C PEAK
 Env. / Ins. : 23°C/54% Engineer : Leo-Li
 EUT : Tablet PC
 Power supply : DC 19V From Adapter input AC 120V/60Hz
 Test mode : 8DPSK 2480MHz Tx
 M/N : T10COT

	Freq. (MHz)	Ant. Factor (dB/m)	Cable loss (dB)	Amp. Factor (dB)	Reading (dBuV)	Emission Level (dBuV/m)	Limits (dBuV/m)	Margin (dB)	Remark
1	2479.920	28.08	6.87	34.45	81.72	82.22	74.00	-8.22	Peak
2	2483.500	28.08	6.90	34.45	44.80	45.33	74.00	28.67	Peak
3	2500.000	28.10	6.90	34.45	44.67	45.22	74.00	28.78	Peak

Remarks:

1. Emission Level= Antenna Factor + Cable Loss -Amp Factor + Reading.
2. The emission levels that are 20dB below the official limit are not reported.

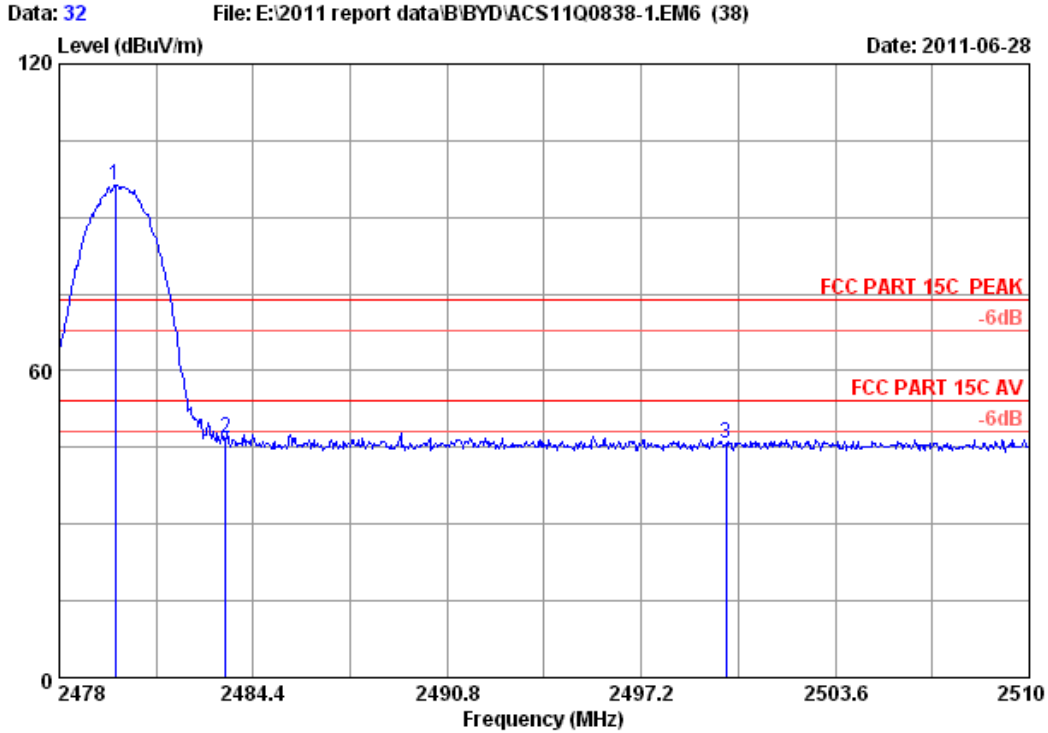

Site no. : 3m Chamber Data no. : 32
 Dis. / Ant. : 3m 2011 3115 4580 Ant. pol. : HORIZONTAL
 Limit : FCC PART 15C PEAK
 Env. / Ins. : 23°C/54% Engineer : Leo-Li
 EUT : Tablet PC
 Power supply : DC 19V From Adapter input AC 120V/60Hz
 Test mode : 8DPSK 2480MHz Tx
 M/N : T10COT

	Freq. (MHz)	Ant. Factor (dB/m)	Cable loss (dB)	Amp. Factor (dB)	Reading (dBuV)	Emission Level (dBuV/m)	Limits (dBuV/m)	Margin (dB)	Remark
1	2479.856	28.08	6.87	34.45	95.81	96.31	74.00	-22.31	Peak
2	2483.500	28.08	6.90	34.45	46.38	46.91	74.00	27.09	Peak
3	2500.000	28.10	6.90	34.45	45.13	45.68	74.00	28.32	Peak

Remarks:

1. Emission Level= Antenna Factor + Cable Loss -amp Factor + Reading.
2. The emission levels that are 20dB below the official limit are not reported.

12. DEVIATION TO TEST SPECIFICATIONS

[NONE]