

FCC PART 15C TEST REPORT FOR CERTIFICATION
On Behalf of

BYD Precision Manufacture Co., Ltd.

Tablet PC

Brand Name	Model No.
TOSHIBA	WT7-C

FCC ID: ZW9-PDW0E

Prepared for : BYD Precision Manufacture Co., Ltd.
No.3001, Baohe Road, Baolong Industrial, Longgang,
Shenzhen, P.R., China

Prepared By : Audix Technology (Shenzhen) Co., Ltd.
No. 6, Ke Feng Rd., 52 Block,
Shenzhen Science & Industrial Park,
Nantou, Shenzhen, Guangdong, China

Tel: (0755) 26639496

Report Number : ACS-F14217
Date of Test : Apr. 18~Jul.01, 2014
Date of Report : Jul.10, 2014

TABLE OF CONTENTS

<u>Description</u>	<u>Page</u>
1. SUMMARY OF STANDARDS AND RESULTS	1-1
1.1. Description of Standards and Results.....	1-1
2. GENERAL INFORMATION.....	2-1
2.1. Description of Device (EUT)	2-1
2.2. Tested Supporting System Details	2-2
2.3. Block Diagram of connection between EUT and simulators	2-2
2.4. Test Information.....	2-2
2.5. Test Facility.....	2-3
2.6. Measurement Uncertainty (95% confidence levels, k=2)	2-4
3. POWER LINE CONDUCTED EMISSION TEST.....	3-1
3.1. Test Equipments.....	3-1
3.2. Block Diagram of Test Setup.....	3-1
3.3. Power Line Conducted Emission Test Limits	3-1
3.4. Configuration of EUT on Test	3-2
3.5. Operating Condition of EUT.....	3-2
3.6. Test Procedure.....	3-2
3.7. Power Line Conducted Emission Test Results.....	3-2
4. RADIATED EMISSION MEASUREMENT	4-1
4.1. Test Equipment	4-1
4.2. Block Diagram of Test Setup.....	4-2
4.3. Radiated Emission Limit.....	4-3
4.4. EUT Configuration on Test.....	4-3
4.5. Operating Condition of EUT.....	4-3
4.6. Test Procedure.....	4-4
4.7. Radiated Emission Test Results	4-4
5. CONDUCTED SPURIOUS EMISSIONS	5-1
5.1. Test Equipment.....	5-1
5.2. Limit.....	5-1
5.3. Test Procedure.....	5-1
6. BAND EDGE COMPLIANCE TEST	6-1
6.1. Test Equipment	6-1
6.2. Limit.....	6-1
6.3. Test Produce	6-1
6.4. Test Results	6-1
7. 6dB BANDWIDTH Test.....	7-1
7.1. Test Equipment	7-1
7.2. Limit.....	7-1
7.3. Test Procedure.....	7-1
7.4. Test Results	7-1
8. OUTPUT POWER TEST	8-1
8.1. Test Equipment	8-1
8.2. Limit (FCC Part 15C 15.247 b(3)).....	8-1
8.3. Test Procedure.....	8-1
8.4. Test Results	8-1
9. POWER SPECTRAL DENSITY TEST	9-1

FCC ID:ZW9-PDW0E

9.1.	Test Equipment	9-1
9.2.	Limit	9-1
9.3.	Test Procedure.....	9-1
9.4.	Test Results	9-2
10.	ANTENNA REQUIREMENT	10-1
10.1.	STANDARD APPLICABLE	10-1
10.2.	ANTENNA CONNECTED CONSTRUCTION	10-1
11.	DEVIATION TO TEST SPECIFICATIONS	11-1
12.	PHOTOGRAPH OF TEST.....	12-1
12.1.	Photos of Power Line Conducted Emission Test	12-1
12.2.	Photos of Radiated Emission Test.....	12-2
13.	PHOTOGRAPH OF EUT.....	13-1

TEST REPORT CERTIFICATION

Applicant : BYD Precision Manufacture Co., Ltd.
 Manufacturer : TOSHIBA CORPORATION
 EUT Description : Tablet PC
 FCC ID : ZW9-PDW0E

(A) MODEL NO.& BRAND NAME	: Brand Name TOSHIBA	Model No. WT7-C
------------------------------	-------------------------	--------------------

(B) SERIAL NO. : N/A
 (C) POWER SUPPLY : 100-240V, 50-60Hz
 (D) TEST VOLTAGE : DC 5V From Adapter Input AC 120V/60Hz

Tested for comply with:
 FCC Rules and Regulations Part 15 Subpart C: 2013
 Test procedure used:
 ANSI C63.10 :2009

The device described above is tested by AUDIX TECHNOLOGY (SHENZHEN) CO., LTD. to confirm comply with all the FCC Part 15 Subpart C requirements.

The test results are contained in this test report and AUDIX TECHNOLOGY (SHENZHEN) CO., LTD. is assumed full responsibility for the accuracy and completeness of these tests. This report contains data that are not covered by the NVLAP accreditation. Also, this report shows that the Equipment Under Test (EUT) is to be technically compliant with the FCC and IC requirements.

This Report is made under FCC Part 2.1075. No modifications were required during testing to bring this product into compliance.

This report applies to above tested sample only. This report shall not be reproduced in part without written approval of AUDIX TECHNOLOGY (SHENZHEN) CO., LTD.

The report must not be used by the client to claim product certification, approval, or endorsement by NVLAP, NIST, or any agency of the federal government.

Date of Test : Apr. 20~Jul.01, 2014 Report of date: Jul.10, 2014

Prepared by : Sonia Lee Reviewed by : Sunny Lu
 Sonia Lee / Assistant Sunny Lu / Assistant Manager

信華科技 (深圳) 有限公司
 Audix Technology (Shenzhen) Co., Ltd.
 EMC 部門報告專用章

Stamp only for EMC Dept. Report

Signature: David Jin

Approved & Authorized Signer : David Jin
 David Jin / Manager

1. SUMMARY OF STANDARDS AND RESULTS

1.1. Description of Standards and Results

The EUT have been tested according to the applicable standards as referenced below.

EMISSION		
Description of Test Item	Standard	Results
Power Line Conducted Emission	FCC Part 15: 15.207 ANSI C63.10 :2009	PASS
Radiated Emission	FCC Part 15: 15.209 ANSI C63.10 :2009	PASS
Band Edge Compliance	FCC Part 15: 15.247 ANSI C63.10 :2009	PASS
Conducted spurious emissions	FCC Part 15: 15.247 ANSI C63.10 :2009	PASS
6dB Bandwidth	FCC Part 15: 15.247 ANSI C63.10 :2009	PASS
Peak Output Power	FCC Part 15: 15.247 ANSI C63.10 :2009	PASS
Power Spectral Density	FCC Part 15: 15.247 ANSI C63.10 :2009	PASS
Antenna requirement	FCC Part 15: 15.203	PASS

2. GENERAL INFORMATION

2.1. Description of Device (EUT)

Product Name : Tablet PC

Model Number & Brand Name :

Brand Name	Model No.
TOSHIBA	WT7-C

FCC ID : ZW9-PDW0E

Radio : Bluetooth V3.0+EDR; IEEE 802.11b/g/n
Bluetooth V4.0

Operation Frequency : IEEE 802.11b: 2412MHz—2462MHz
IEEE 802.11g: 2412MHz—2462MHz
IEEE802.11nHT20: 2412MHz—2462MHz
IEEE802.11nHT40: 2422MHz—2452MHz
Bluetooth: 2402-2480MHz

Channel Number : IEEE 802.11b/g, IEEE 802.11n HT20: 11 Channels,
IEEE 802.11n HT40: 7 Channels
Bluetooth V3.0+EDR: 79
Bluetooth V4.0: 40

Modulation Technology : IEEE 802.11b: DSSS(CCK,DQPSK,DBPSK)
IEEE 802.11g: OFDM(64QAM, 16QAM, QPSK, BPSK)
IEEE 802.11n HT20/ HT40: OFDM (64QAM, 16QAM, QPSK,BPSK)
Bluetooth V3.0+EDR: GFSK, $\pi/4$ DQPSK, 8DPSK
Bluetooth V4.0: GFSK

Antenna Assembly Gain : IFA, 2.68dBi PK Gain

Applicant : BYD Precision Manufacture Co., Ltd.
No.3001, Baohe Road, Baolong Industrial, Longgang,
Shenzhen, P. R., China

Manufacturer : TOSHIBA CORPORATION
1-1, Shibaura 1-Chome, Minato-ku, Tokyo, Japan

Power Adapter : Manufacturer: Meic Model No.: MN-A208-L120

USB Cable : Shielded, Detachable, 900mm

Date of Test : Apr. 20~Jul.01, 2014

Date of Receipt : Apr.01, 2014

Sample Type : Prototype production

2.2. Tested Supporting System Details

No.	Description	ACS No.	Manufacturer	Model	Serial Number	Approved type
1.	Headphone	ACS-EMC-EP01	OVANN	OV880V	N/A	<input type="checkbox"/> FCC ID <input type="checkbox"/> BSMI ID
Cable: Shielded, Undetachabled, 4.0m						

2.3. Block Diagram of connection between EUT and simulators

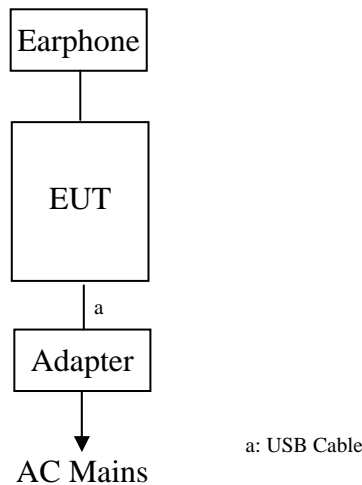

(EUT: Tablet PC)

2.4. Test Information

A special test software was used to control EUT work in Continuous TX mode(100% duty cycle), and select test channel, wireless mode and data rate.

Tested mode, channel, and data rate information			
Mode	data rate (Mbps)(see Note)	Channel	Frequency (MHz)
IEEE 802.11b	1	Low :CH1	2412
	1	Middle: CH6	2437
	1	High: CH11	2462
IEEE 802.11g	6	Low :CH1	2412
	6	Middle: CH6	2437
	6	High: CH11	2462
IEEE 802.11n HT20	6.5	Low :CH1	2412
	6.5	Middle: CH6	2437
	6.5	High: CH11	2462
IEEE 802.11n HT40	13.5	Low :CH1	2422
	13.5	Middle: CH4	2437
	13.5	High: CH7	2452

Note: According exploratory test, EUT will have maximum output power in those data rate, so those data rate were used for all test.

2.5. Test Facility

Site Description

Name of Firm : Audix Technology (Shenzhen) Co., Ltd.
No. 6, Ke Feng Rd., 52 Block, Shenzhen
Science & Industrial Park, Nantou,
Shenzhen, Guangdong, China

3m Anechoic Chamber : Certificated by FCC, USA
Registration Number: 90454
Valid Date: Feb.22, 2015

3m & 10m Anechoic Chamber : Certificated by FCC, USA
Registration Number: 794232
Valid Date: Oct.31, 2015

EMC Lab. : Certificated by Industry Canada
Registration Number: IC 5183A-1
Valid Date: May.14, 2017

: Certificated by DAkkS, Germany
Registration No: D-PL-12151-01-00
Valid Date: Dec.15, 2016

Accredited by NVLAP, USA
NVLAP Code: 200372-0
Valid Date: Mar.31, 2015

2.6.Measurement Uncertainty (95% confidence levels, k=2)

Test Item	Uncertainty	Memo
Uncertainty for Conducted emission test in No. 1 Conduction	±3.10 dB	150KHz to 30MHz
Uncertainty for Radiated Emission test in 3m chamber	±3.22 dB	30~200MHz, Polarization: H
	±3.23 dB	30~200MHz, Polarization: V
	±3.49 dB	200M~1GHz, Polarization: H
	±3.39 dB	200M~1GHz, Polarization: V
Uncertainty for Radiated Spurious Emission test	±3.57 dB	
Uncertainty for Conducted Spurious emission test	±2.00 dB	
Uncertainty for Output power test	±0.73 dB	
Uncertainty for Power density test	±2.00 dB	
Uncertainty for Temperature and humidity test for ETSI	±3%	
	±0.6°C	
Uncertainty for Radio Frequency	±7x10 ⁻⁸	
Uncertainty for Bandwidth	±83 KHz	
Uncertainty for radiated electromagnetic disturbances	±2.92 dB	
RF level uncertainty for given BER	±0.2 dB	

3. POWER LINE CONDUCTED EMISSION TEST

3.1. Test Equipments

Item	Equipment	Manufacturer	Model No.	Serial No.	Last Cal.	Cal. Interval
1.	1# Shielding Room	AUDIX	N/A	N/A	Apr.17,14	1 Year
2.	Test Receiver	Rohde & Schwarz	ESHS10	838693/001	Oct.31, 13	1 Year
3.	L.I.S.N.#1	Rohde & Schwarz	ESH2-Z5	100429	Jan.22, 14	1 Year
4.	L.I.S.N.#3	Kyoritsu	KNW-242C	8-1920-1	Apr. 28,14	1 Year
5.	Terminator	Hubersuhner	50Ω	No. 1	Apr. 28,14	1 Year
6.	Terminator	Hubersuhner	50Ω	No. 2	Apr. 28,14	1 Year
7.	RF Cable	Hubersuhner	RG58	0100.6954.20#	Jan.22, 14	1Year
8.	Coaxial Switch	Anritsu	MP59B	6200298346	Apr. 28,14	1 Year
9.	Pulse Limiter	Rohde & Schwarz	ESH3-Z2	101838	Jan.22, 14	1 Year

3.2. Block Diagram of Test Setup

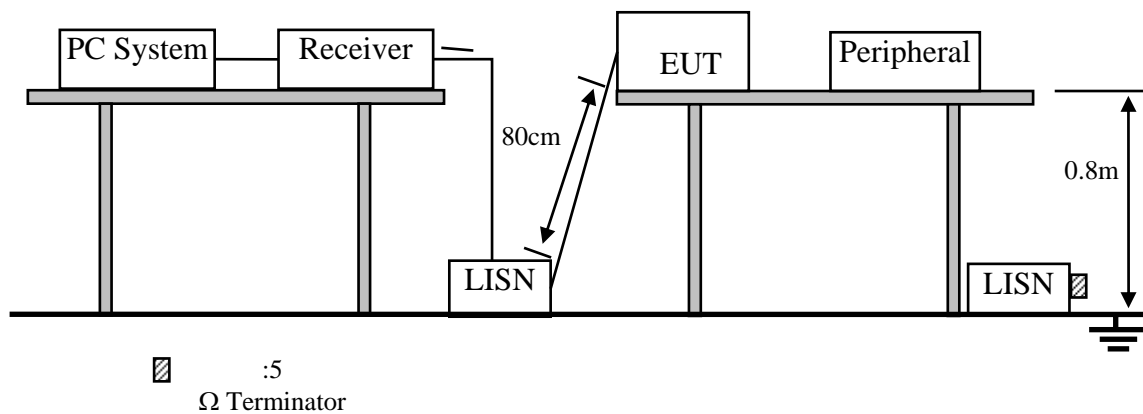

3.3. Power Line Conducted Emission Test Limits

Frequency	Maximum RF Line Voltage	
	Quasi-Peak Level dB(μV)	Average Level dB(μV)
150kHz ~ 500kHz	66 ~ 56*	56 ~ 46*
500kHz ~ 5MHz	56	46
5MHz ~ 30MHz	60	50

Notes: 1. * Decreasing linearly with logarithm of frequency.
2. The lower limit shall apply at the transition frequencies.

3.4. Configuration of EUT on Test

The following equipment are installed on Power Line Conducted Emission Test to meet the commission requirement and operating regulations in a manner which tends to maximize its emission characteristics in a normal application.

3.4.1. HP Slate 7 (EUT)

Model Number : WT7-C

Serial Number : N/A

3.5. Operating Condition of EUT

3.5.1. Setup the EUT and simulator as shown as Section 3.2.

3.5.2. Turned on the power of all equipment.

3.5.3. Let the EUT work in test mode (TX Mode) and measure it.

3.6. Test Procedure

The EUT was placed on a non-metallic table, 80cm above the ground plane. The EUT Power Via PC connected to the power mains through a line impedance stabilization network (L.I.S.N. 1#). The other peripheral devices power cord connected to the power mains through a line impedance stabilization network (L.I.S.N.#3). This provides a 50 ohm coupling impedance for the EUT (Please refer the block diagram of the test setup and photographs). The AC line are checked to find out the maximum conducted emission. In order to find the maximum emission levels, the relative positions of equipment and all of the interface cables shall be changed according to ANSI C63.10: 2009 on Conducted Emission Test.

The bandwidth of test receiver (R & S ESHS10) is set at 9kHz.

The frequency range from 150kHz to 30MHz is checked.

3.7. Power Line Conducted Emission Test Results

PASS. (All emissions not reported below are too low against the prescribed limits.)

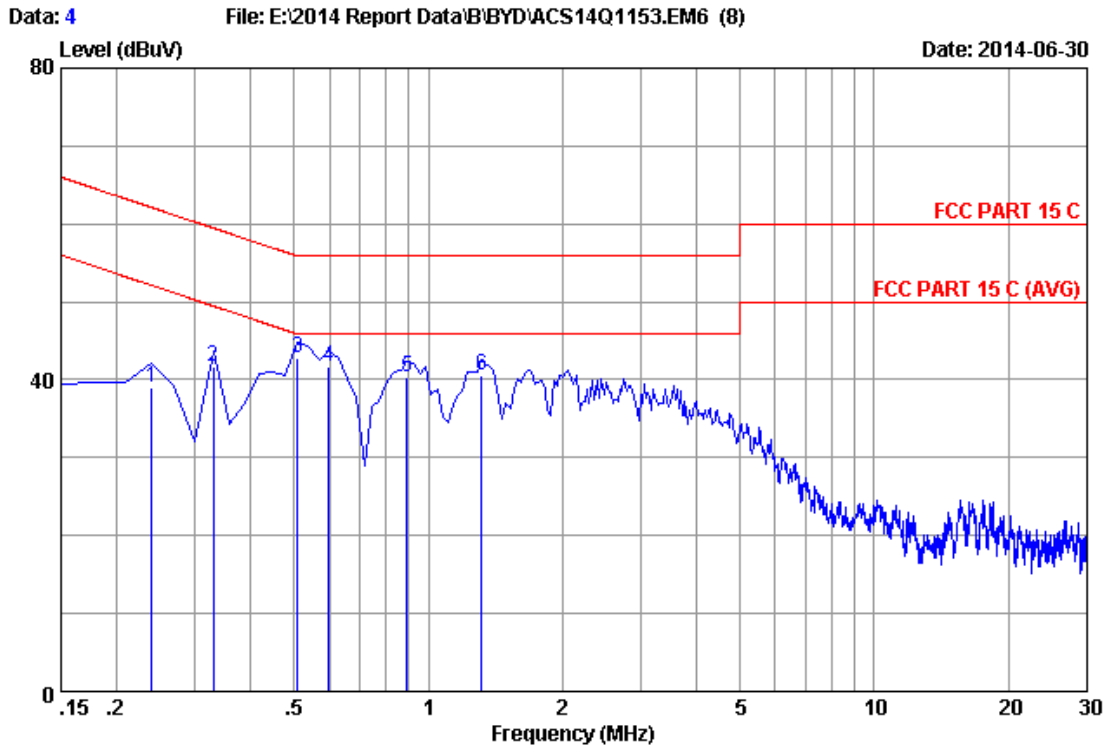

Site no :1#conduction Data No :4
 Dis./Ant. :2014 ESH2-25 LINE
 Limit :FCC PART 15 C
 Env./Ins. :24.3°C/42% Engineer :Kevin_Hu
 EUT :Tablet PC
 Power Rating :DC 5V From Adapter Input AC 120V/60Hz
 Test Mode :TX Mode (WIFI)
 M/N: WT7-C

No	Freq (MHz)	LISN Factor (dB)	Cable Loss (dB)	Reading (dBuV)	Emission Level (dBuV)	Limits (dBuV)	Margin (dB)	Remark
1	0.23955	0.13	9.88	29.02	39.03	62.11	23.08	QP
2	0.32910	0.14	9.88	31.62	41.64	59.47	17.83	QP
3	0.50820	0.15	9.88	32.75	42.78	56.00	13.22	QP
4	0.59775	0.16	9.89	31.70	41.75	56.00	14.25	QP
5	0.89625	0.17	9.89	30.26	40.32	56.00	15.68	QP
6	1.314	0.18	9.90	30.58	40.66	56.00	15.34	QP

Remarks: 1. Emission Level=LISN Factor+Cable Loss(Include 10dB pulse limit)+Reading.
 2. If the average limit is met when using a quasi-peak detector, the EUT shall be deemed to meet both limits and measurement with average detector is unnecessary.

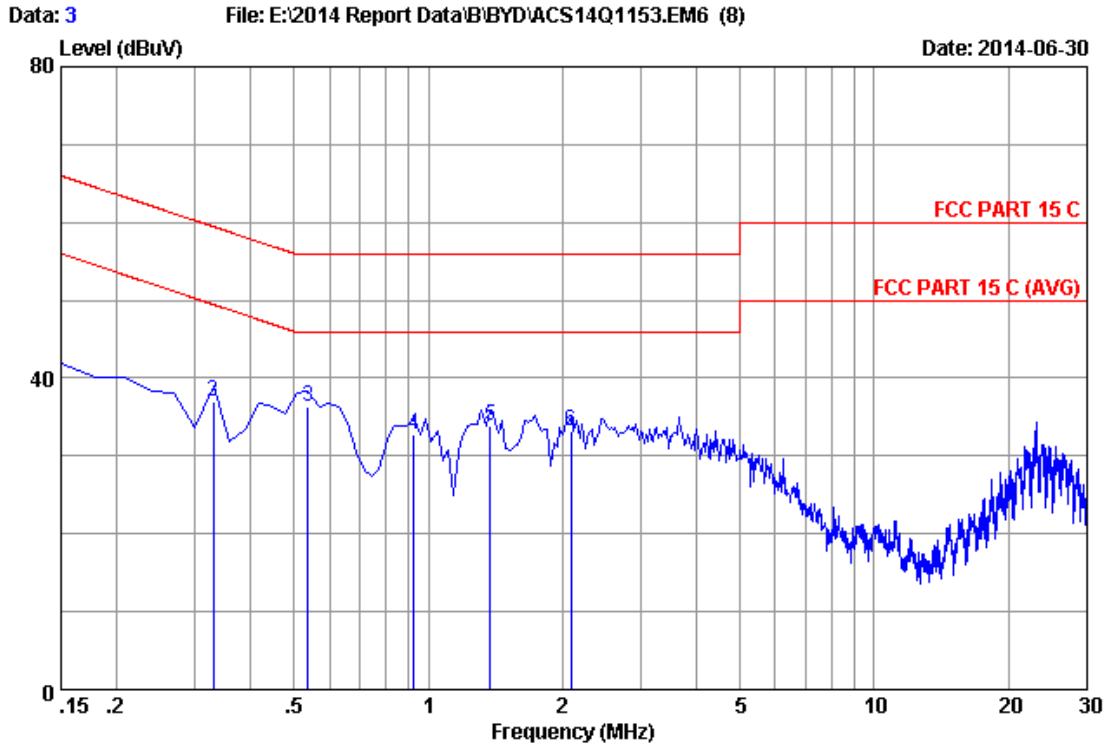

Site no :1#conduction Data No :3
 Dis./Ant. :2014 ESH2-25 NEUTRAL
 Limit :FCC PART 15 C
 Env./Ins. :24.3*C/42% Engineer :Kevin_Hu
 EUT :Tablet PC
 Power Rating :DC 5V From Adapter Input AC 120V/60Hz
 Test Mode :TX Mode (WIFI)
 M/N:WT7-C

No	Freq (MHz)	LISN Factor (dB)	Cable Loss (dB)	Reading (dBuV)	Emission Level (dBuV)	Limits (dBuV)	Margin (dB)	Remark
1	0.15000	0.13	9.87	29.82	39.82	66.00	26.18	QP
2	0.32910	0.14	9.88	27.00	37.02	59.47	22.45	QP
3	0.53805	0.15	9.88	26.34	36.37	56.00	19.63	QP
4	0.92610	0.17	9.89	22.81	32.87	56.00	23.13	QP
5	1.374	0.18	9.90	23.88	33.96	56.00	22.04	QP
6	2.090	0.20	9.91	23.15	33.26	56.00	22.74	QP

Remarks: 1.Emission Level=LISN Factor+Cable Loss(Include 10dB pulse limit)+Reading.
 2.If the average limit is met when using a quasi-peak detector, the EUT shall be deemed to meet both limits and measurement with average detector is unnecessary.

4. RADIATED EMISSION MEASUREMENT

4.1. Test Equipment

Frequency rang: 30~1000MHz

Item	Equipment	Manufacturer	Model No.	Serial No.	Last Cal.	Cal. Interval
1	3#Chamber	AUDIX	N/A	N/A	Nov.24, 13	1 Year
2	EMI Spectrum	Agilent	E4407B	MY41440292	Apr. 28,14	1 Year
3	Test Receiver	Rohde & Schwarz	ESVS10	834468/011	Apr. 28,14	1 Year
4	Amplifier	HP	8447D	2648A04738	Apr. 28,14	1 Year
5	Bilog Antenna	Schaffner	CBL6111C	35375	Apr. 08,14	1 Year
6	RF Cable	MIYAZAKI	CFD400-NL	3# Chamber No.1	Apr. 28,14	1 Year
7	Coaxial Switch	Anritsu	MP59B	M74389	Apr. 28,14	1 Year

Frequency rang: above 1GHz~25GHz

Item	Equipment	Manufacturer	Model No.	Serial No.	Last Cal.	Cal. Interval
1	Spectrum Analyzer	Agilent	E4446A	US44300459	Apr. 28,14	1 Year
2	Horn Antenna	EMCO	3115	9607-4877	Aug.27, 13	1 Year
3	Amplifier	Agilent	8449B	3008A02495	Apr. 28,14	1 Year
4	RF Cable	Hubersuhner	SUCOFLEX106	77977/6	Apr. 28,14	1 Year
5	RF Cable	Hubersuhner	SUCOFLEX106	28616/2	Apr. 28,14	1 Year
6	Horn Antenna	EMCO	3116	00060089	Aug.27, 13	1 Year

4.2. Block Diagram of Test Setup

For frequency range 30MHz-1000MHz

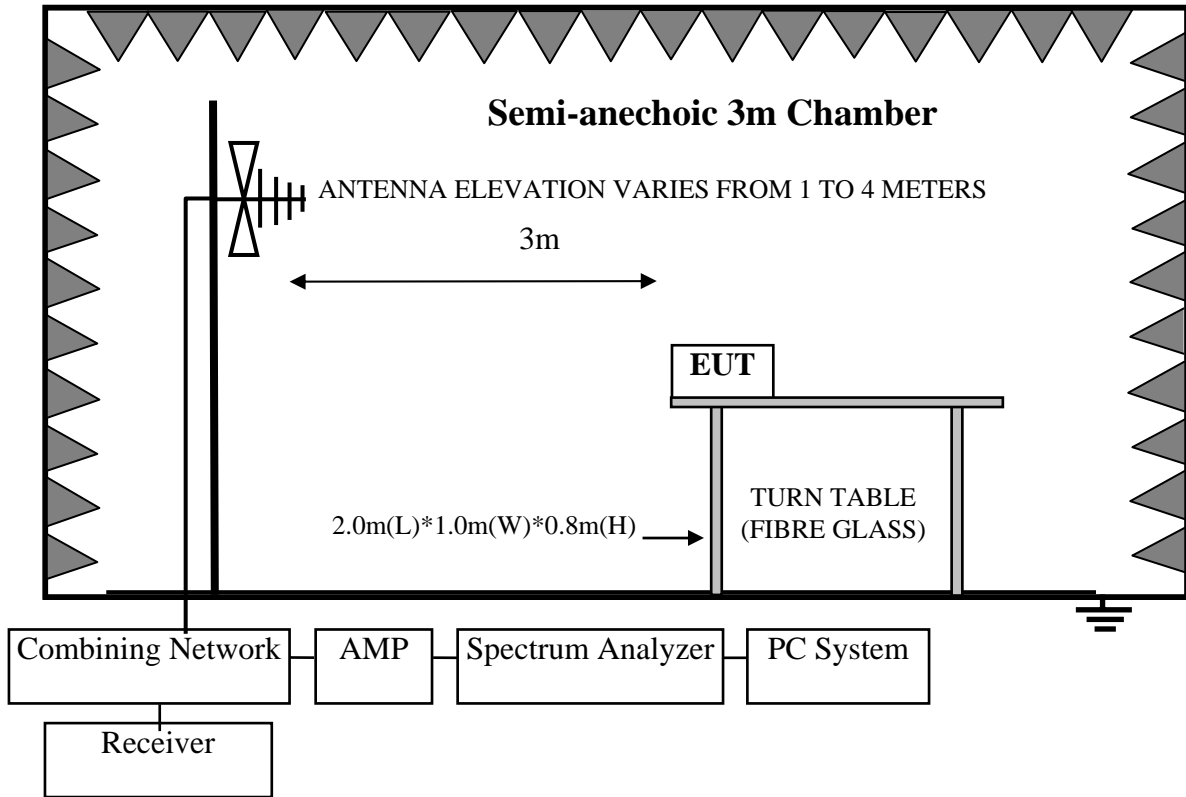

For frequency range above 1GHz~25GHz

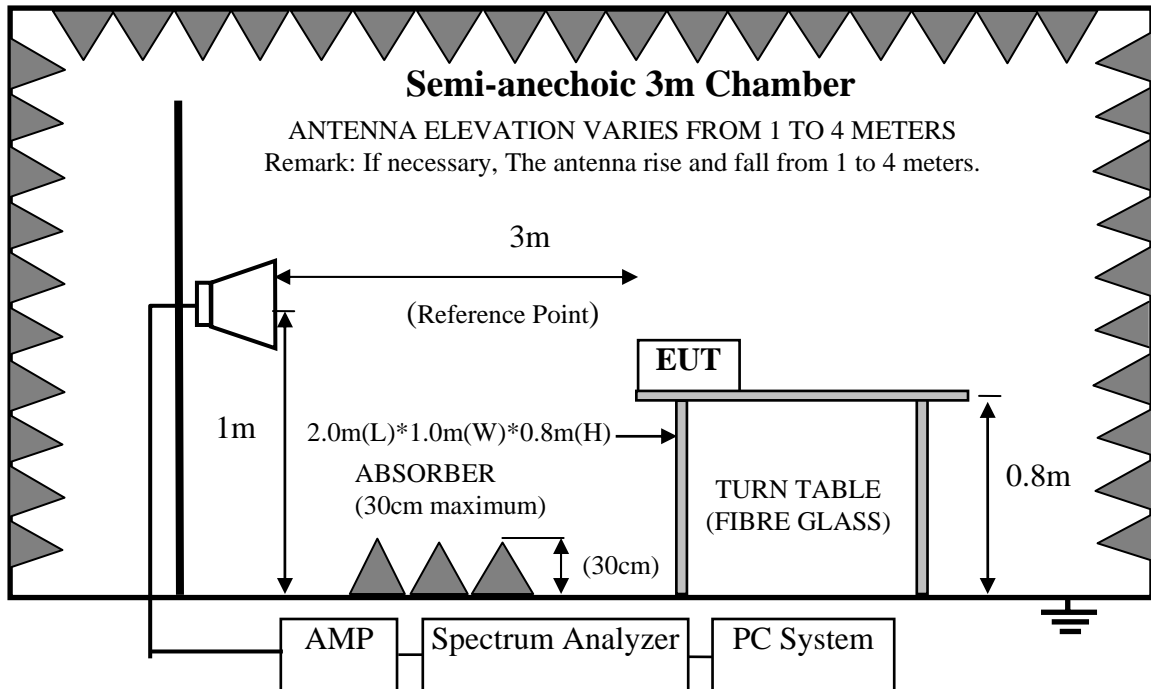

4.3. Radiated Emission Limit

4.3.1. 15.209 limits

FREQUENCY MHz	DISTANCE Meters	FIELD STRENGTHS LIMIT	
		μV/m	dB(μV)/m
30 ~ 88	3	100	40.0
88 ~ 216	3	150	43.5
216 ~ 960	3	200	46.0
960 ~ 1000	3	500	54.0
Above 1000	3	74.0 dB(μV)/m (Peak) 54.0 dB(μV)/m (Average)	

Remark : (1) Emission level dBμV = 20 log Emission level μV/m

(2) The smaller limit shall apply at the cross point between two frequency bands.

(3) Distance is the distance in meters between the measuring instrument, antenna and the closest point of any part of the device or system.

4.3.2. 15.205 Restricted bands of operation

MHz	MHz	MHz	GHz
0.090 - 0.110	16.42 - 16.423	399.9 - 410	4.5 - 5.15
¹ 0.495 - 0.505	16.69475 - 16.69525	608 - 614	5.35 - 5.46
2.1735 - 2.1905	16.80425 - 16.80475	960 - 1240	7.25 - 7.75
4.125 - 4.128	25.5 - 25.67	1300 - 1427	8.025 - 8.5
4.17725 - 4.17775	37.5 - 38.25	1435 - 1626.5	9.0 - 9.2
4.20725 - 4.20775	73 - 74.6	1645.5 - 1646.5	9.3 - 9.5
6.215 - 6.218	74.8 - 75.2	1660 - 1710	10.6 - 12.7
6.26775 - 6.26825	108 - 121.94	1718.8 - 1722.2	13.25 - 13.4
6.31175 - 6.31225	123 - 138	2200 - 2300	14.47 - 14.5
8.291 - 8.294	149.9 - 150.05	2310 - 2390	15.35 - 16.2
8.362 - 8.366	156.52475 - 156.52525	2483.5 - 2500	17.7 - 21.4
8.37625 - 8.38675	156.7 - 156.9	2690 - 2900	22.01 - 23.12
8.41425 - 8.41475	162.0125 - 167.17	3260 - 3267	23.6 - 24.0
12.29 - 12.293	167.72 - 173.2	3332 - 3339	31.2 - 31.8
12.51975 - 12.52025	240 - 285	3345.8 - 3358	36.43 - 36.5
12.57675 - 12.57725	322 - 335.4	3600 - 4400	(²)

All the emissions appearing within 15.205 restricted frequency bands shall not exceed the limits shown in 15.209, all the other emissions shall be at least 20dB below the fundamental emissions, or comply with 15.209 limits.

4.4. EUT Configuration on Test

The configurations of EUT are listed in Section 3.5.

4.5. Operating Condition of EUT

Same as Conducted Emission test that is listed in Section 3.6. except the test set up replaced by Section 4.2.

4.6. Test Procedure

EUT and its simulators are placed on a turn table, which is 0.8 meter high above ground. The turn table can rotate 360 degrees to determine the position of the maximum emission level. Power on the EUT and let it working in test mode, then test it. EUT is set 3 meters away from the receiving antenna, which is mounted on a antenna tower. The antenna can be moved up and down between 1 meter and 4 meters to find out the maximum emission level. Broadband antenna (calibrated bilog antenna) is used as receiving antenna. Both horizontal and vertical polarization of the antenna are set on test. In order to find the maximum emission levels, all of the interface cables must be manipulated according to ANSI C63.10-2009 on radiated emission Test.

The EUT was tested at X.Y.Z position and found the worst case position reported in the report.

The bandwidth of the EMI test receiver (R&S ESVS10) is set at 120kHz for frequency range from 30MHz to 1000 MHz.

The bandwidth of the Spectrum's VBW is set at 3MHz and RBW is set at 1MHz for peak emissions measurement above 1GHz and 1MHz RBW, 10Hz VBW for average emissions measure above 1GHz

The frequency range from 30MHz to 10th harmonic (25GHz) are checked. and no any emissions were found from 18GHz to 25 GHz, So the radiated emissions from 18GHz to 25GHz were not record.

4.7. Radiated Emission Test Results

PASS.

All the emissions from 30MHz to 25 GHz were comply with 15.209 limits.

Note: For emissions above 1GHz, if peak level comply with average limit, then the average level is deemed to comply with average limit.

Frequency: 30MHz~1GHz

Data: 3

File: E:\2014 Report Data\B\BYD\ACS14Q1153.EM6 (12)

Date: 2014-06-30

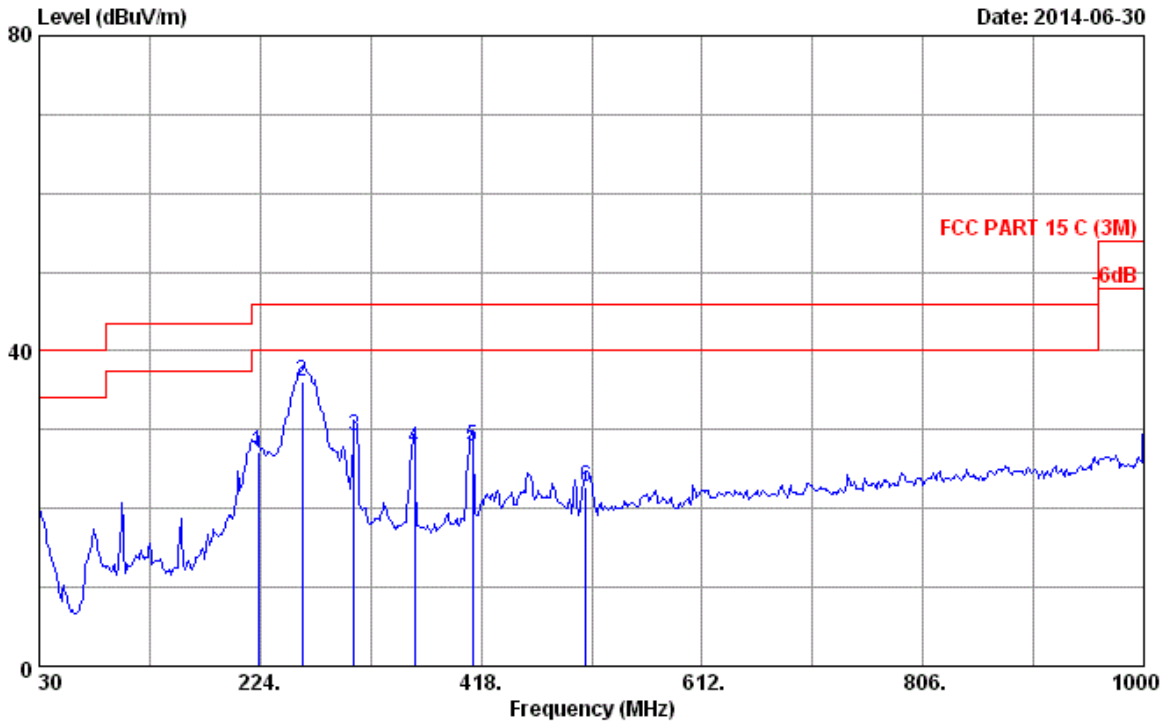

Site no. : 3m Chamber Data no. : 3
 Dis. / Ant. : 3m 2013 CBL6112D 35375 Ant. pol. : HORIZONTAL
 Limit : FCC PART 15 C (3M)
 Env. / Ins. : 24°C/34% Engineer : Kevin_Hu
 EUT : Tablet PC
 Power rating : DC 5V From Adapter Input AC 120V/60Hz
 Test Mode : Tx Mode(WIFI)
 M/N: WT7-C

No.	Freq. (MHz)	Ant. Factor (dB/m)	Cable Loss (dB)	Reading (dBuV)	Emission Level (dBuV/m)	Limits (dBuV/m)	Margin (dB)	Remark
1	222.06	10.70	1.87	14.57	27.14	46.00	18.86	QP
2	260.86	14.00	2.02	20.10	36.12	46.00	9.88	QP
3	306.45	14.13	2.19	12.94	29.26	46.00	16.74	QP
4	359.80	15.70	2.34	9.69	27.73	46.00	18.27	QP
5	410.24	17.11	2.49	8.19	27.79	46.00	18.21	QP
6	510.15	18.20	2.78	1.84	22.82	46.00	23.18	QP

Remarks: 1. Emission Level= Antenna Factor + Cable Loss + Reading.
 2. The emission levels that are 20dB below the official limit are not reported.

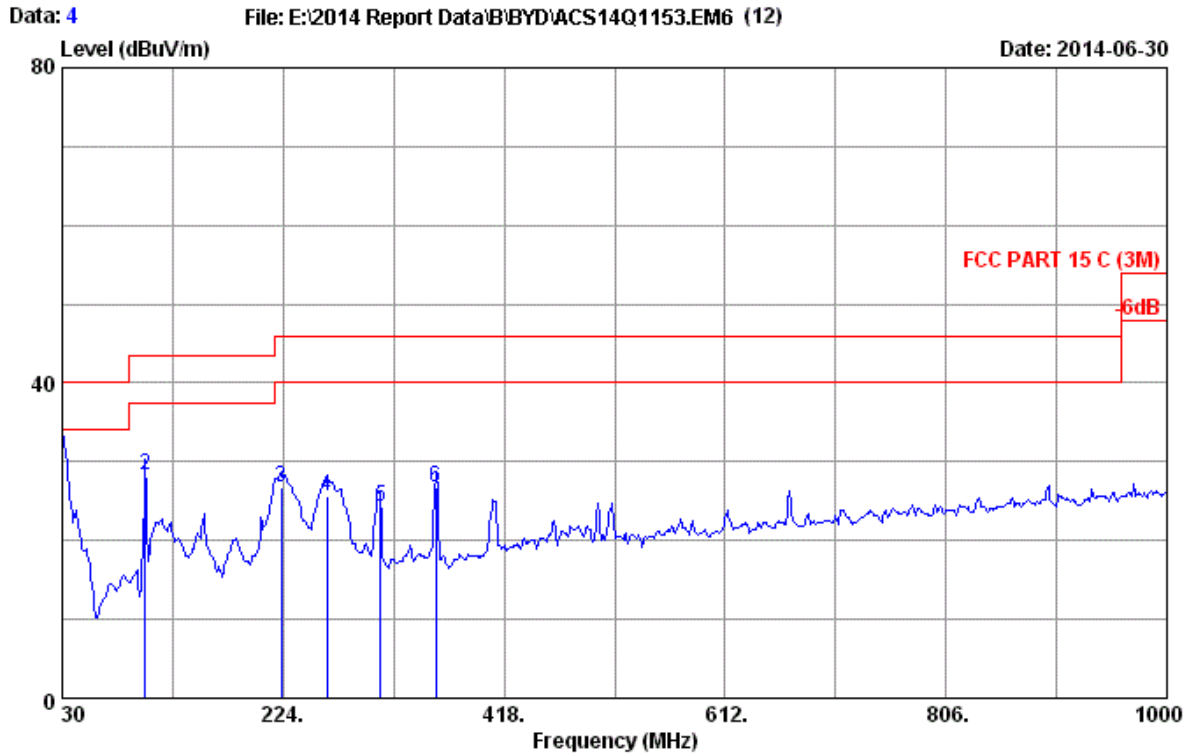

Site no. : 3m Chamber Data no. : 4
 Dis. / Ant. : 3m 2013 CBL6112D 35375 Ant. pol. : VERTICAL
 Limit : FCC PART 15 C (3M)
 Env. / Ins. : 24°C/34% Engineer : Kevin_Hu
 EUT : Tablet PC
 Power rating : DC 5V From Adapter Input AC 120V/60Hz
 Test Mode : Tx Mode(WIFI)
 M/N: WT7-C

No.	Freq. (MHz)	Ant. Factor (dB/m)	Cable Loss (dB)	Reading (dBuV)	Emission Level (dBuV/m)	Limits (dBuV/m)	Margin (dB)	Remark
1	30.00	20.10	0.83	10.69	31.62	40.00	8.38	QP
2	102.75	11.61	1.42	15.19	28.22	43.50	15.28	QP
3	222.06	10.70	1.87	14.09	26.66	46.00	19.34	QP
4	262.80	13.96	2.03	9.74	25.73	46.00	20.27	QP
5	309.36	14.19	2.20	7.90	24.29	46.00	21.71	QP
6	357.86	15.66	2.34	8.73	26.73	46.00	19.27	QP

Remarks: 1. Emission Level= Antenna Factor + Cable Loss + Reading.
 2. The emission levels that are 20dB below the official limit are not reported.

Frequency: 1GHz~18GHz

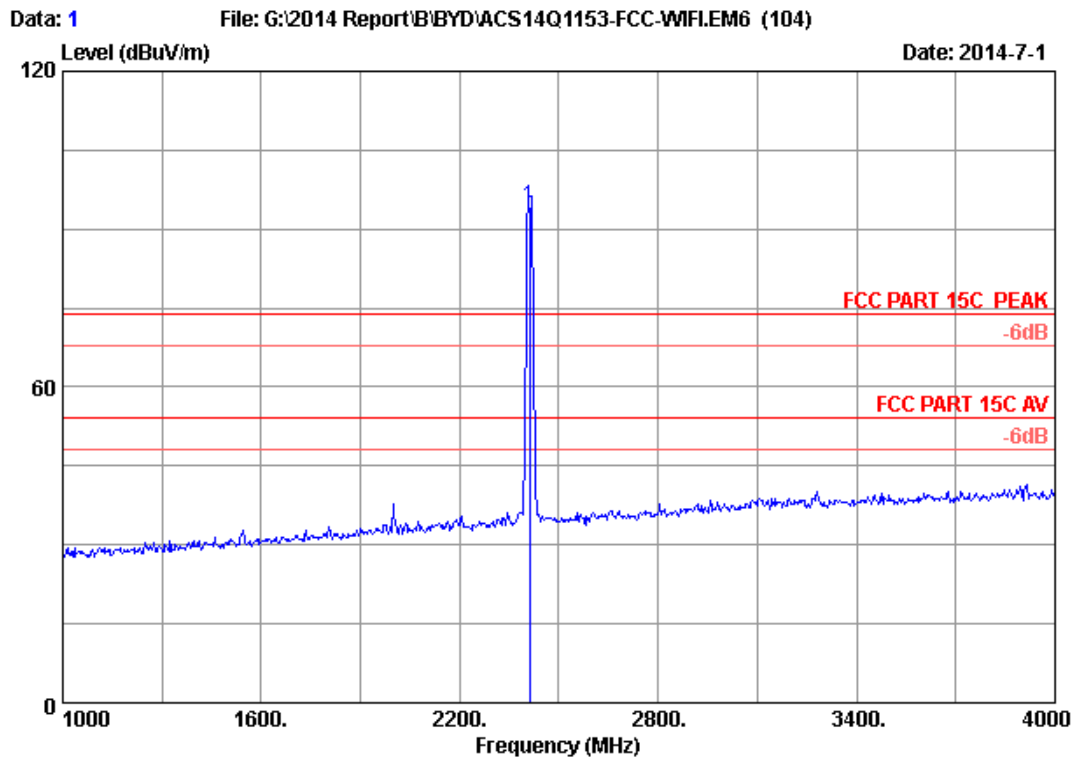

Site no. : 3m Chamber Data no. : 1
 Dis. / Ant. : 3m 2013 3115 (4580) Ant. pol. : VERTICAL
 Limit : FCC PART 15C PEAK
 Env. / Ins. : 24°C/56% Engineer : Kevin_Hu
 EUT : Tablet PC
 Power Rating : DC 5V From Adapter Input AC 120V/60Hz
 Test Mode : IEEE802.11b 2412MHz Tx Mode
 M/N : WT7-C

No.	Freq. (MHz)	Ant. Factor (dB/m)	Cable Loss (dB)	AMP factor (dB)	Reading (dBuV)	Emission Level (dBuV/m)	Limits (dBuV/m)	Margin (dB)	Remark
1	2412.000	28.21	5.81	35.70	96.05	94.37	74.00	-20.37	Peak

Remarks: 1. Emission Level= Antenna Factor + Cable Loss + Reading - Amp Factor
 2. The emission levels that are 20dB below the official limit are not reported.

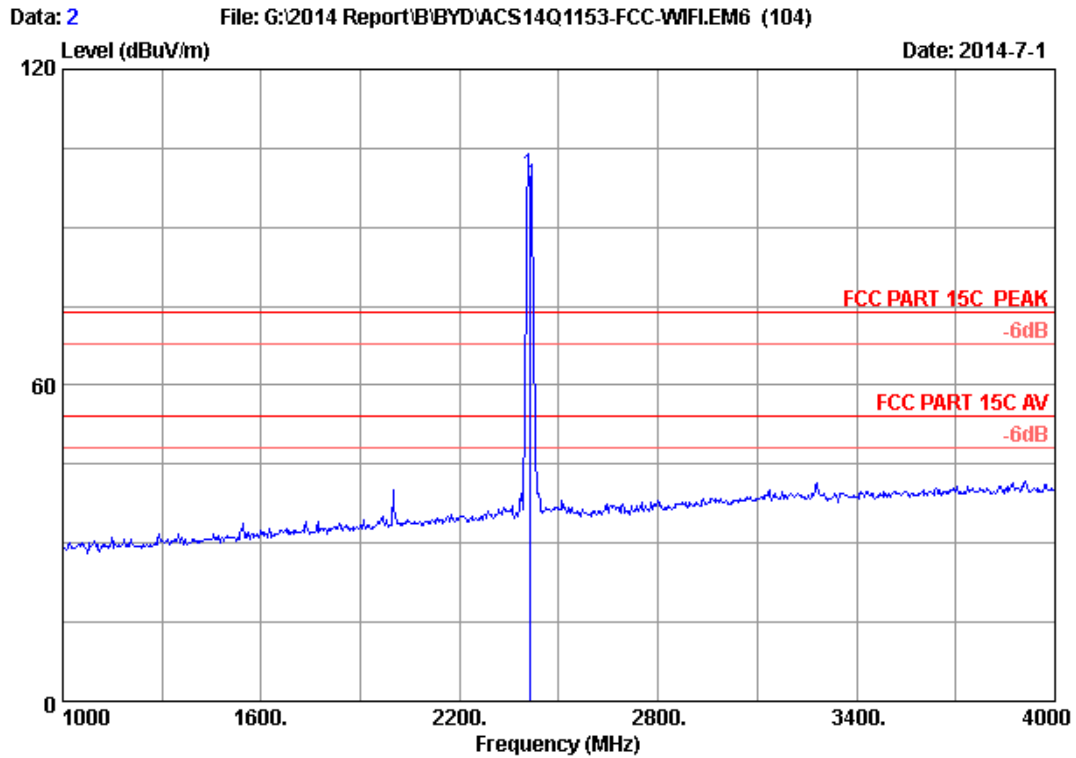

Site no. : 3m Chamber Data no. : 2
 Dis. / Ant. : 3m 2013 3115 (4580) Ant. pol. : HORIZONTAL
 Limit : FCC PART 15C PEAK
 Env. / Ins. : 24°C/56% Engineer : Kevin_Hu
 EUT : Tablet PC
 Power Rating : DC 5V From Adapter Input AC 120V/60Hz
 Test Mode : IEEE802.11b 2412MHz Tx Mode
 M/N : WT7-C

No.	Freq. (MHz)	Ant. Factor (dB/m)	Cable Loss (dB)	AMP factor (dB)	Reading (dBUV)	Emission			Remark
						Level (dBUV/m)	Limits (dBUV/m)	Margin (dB)	
1	2412.000	28.21	5.81	35.70	101.56	99.88	74.00	-25.88	Peak

Remarks: 1. Emission Level= Antenna Factor + Cable Loss + Reading
 -Amp Factor
 2. The emission levels that are 20dB below the official
 limit are not reported.

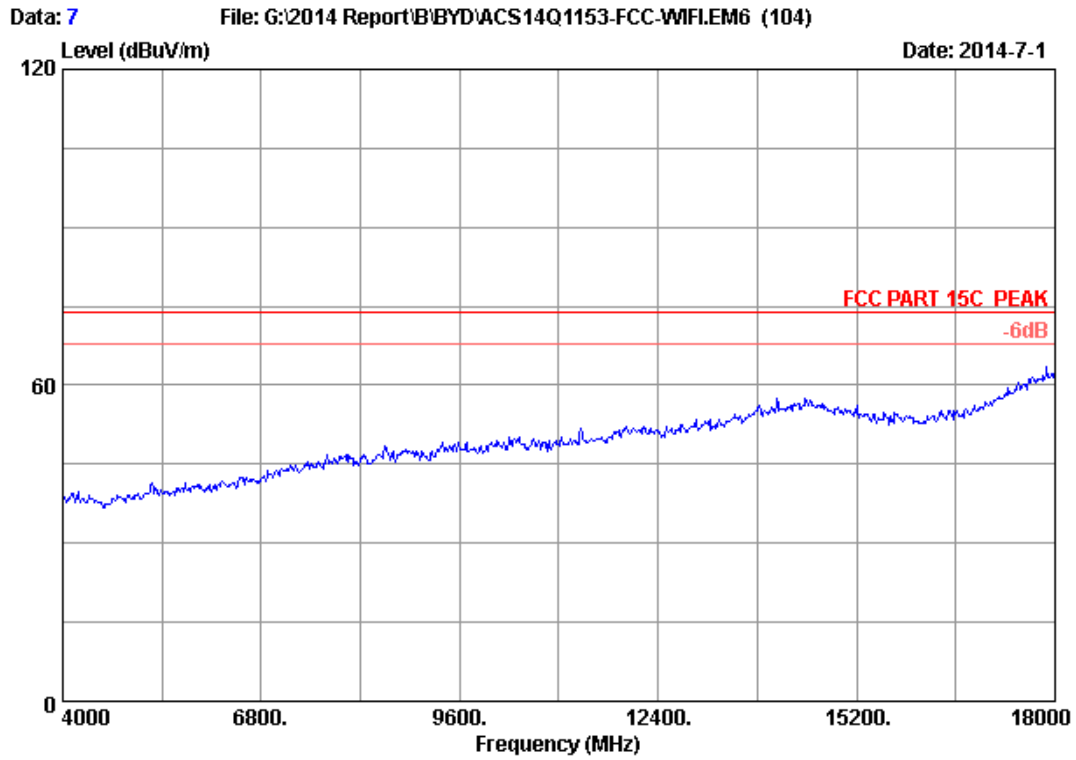

Site no. : 3m Chamber Data no. : 7
Dis. / Ant. : 3m 2013 3115 (4580) Ant. pol. : VERTICAL
Limit : FCC PART 15C PEAK
Env. / Ins. : 24°C/56% Engineer : Kevin_Hu
EUT : Tablet PC
Power Rating : DC 5V From Adapter Input AC 120V/60Hz
Test Mode : IEEE802.11b 2412MHz Tx Mode
M/N : WT7-C

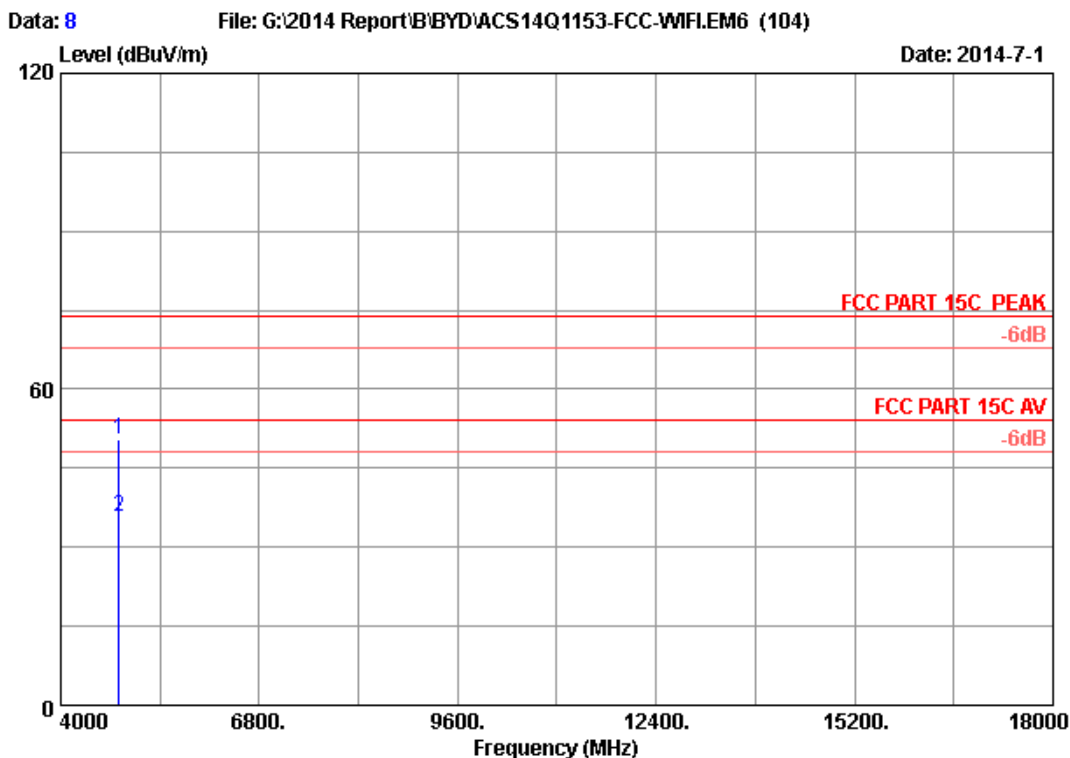

Site no. : 3m Chamber Data no. : 8
 Dis. / Ant. : 3m 2013 3115 (4580) Ant. pol. : VERTICAL
 Limit : FCC PART 15C PEAK
 Env. / Ins. : 24°C/56% Engineer : Kevin_Hu
 EUT : Tablet PC
 Power Rating : DC 5V From Adapter Input AC 120V/60Hz
 Test Mode : IEEE802.11b 2412MHz Tx Mode
 M/N : WT7-C

No.	Freq. (MHz)	Ant. Factor (dB/m)	Cable Loss (dB)	AMP factor (dB)	Reading (dBuV)	Emission Level (dBuV/m)	Limits (dBuV/m)	Margin (dB)	Remark
1	4824.000	32.88	8.58	35.70	44.86	50.62	74.00	23.38	Peak
2	4824.000	32.88	8.58	35.70	30.08	35.84	54.00	18.16	Average

Remarks: 1. Emission Level= Antenna Factor + Cable Loss + Reading - Amp Factor
 2. The emission levels that are 20dB below the official limit are not reported.

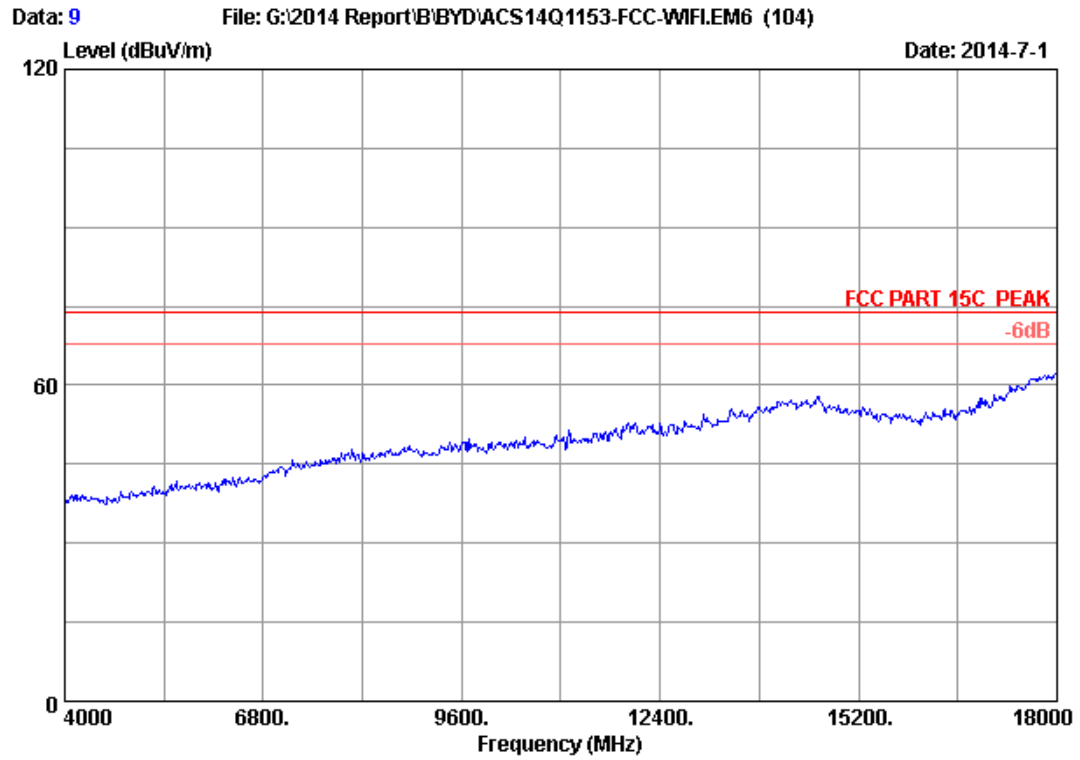

Site no. : 3m Chamber Data no. : 9
Dis. / Ant. : 3m 2013 3115 (4580) Ant. pol. : HORIZONTAL
Limit : FCC PART 15C PEAK
Env. / Ins. : 24°C/56% Engineer : Kevin_Hu
EUT : Tablet PC
Power Rating : DC 5V From Adapter Input AC 120V/60Hz
Test Mode : IEEE802.11b 2412MHz Tx Mode
M/N : WT7-C

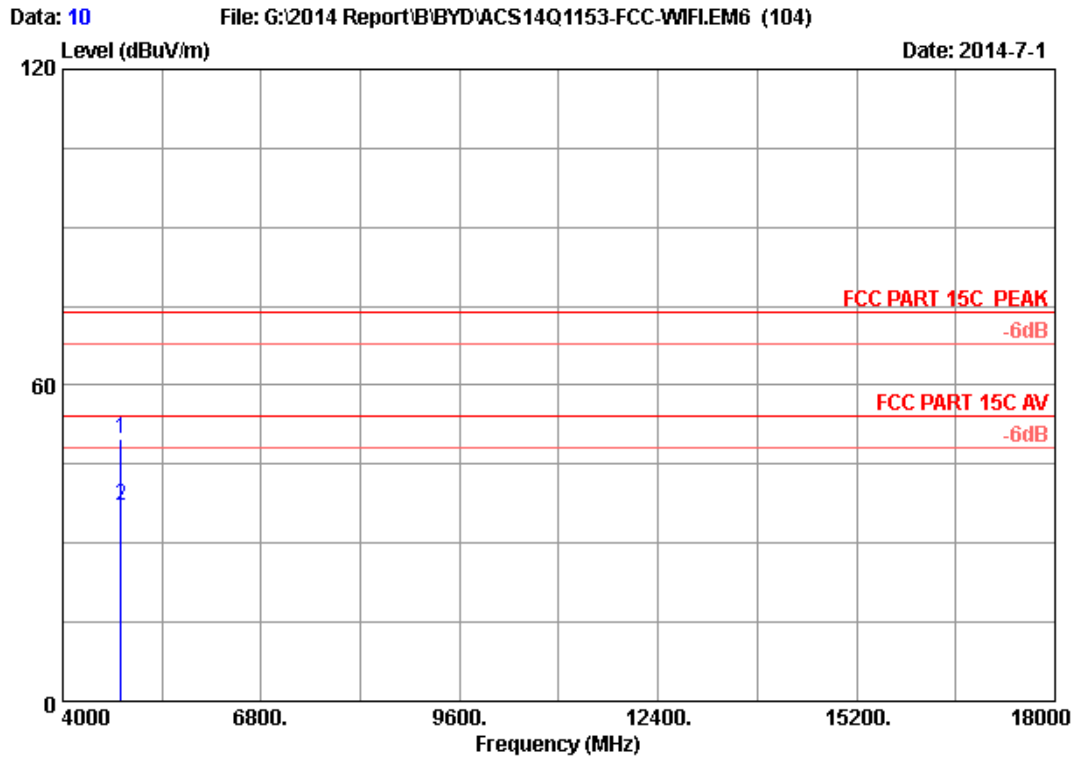

Site no. : 3m Chamber Data no. : 10
 Dis. / Ant. : 3m 2013 3115 (4580) Ant. pol. : HORIZONTAL
 Limit : FCC PART 15C PEAK
 Env. / Ins. : 24°C/56% Engineer : Kevin_Hu
 EUT : Tablet PC
 Power Rating : DC 5V From Adapter Input AC 120V/60Hz
 Test Mode : IEEE802.11b 2412MHz Tx Mode
 M/N : WT7-C

No.	Freq. (MHz)	Ant. Factor (dB/m)	Cable Loss (dB)	AMP factor (dB)	Reading (dBuV)	Emission Level (dBuV/m)	Limits (dBuV/m)	Margin (dB)	Remark
1	4824.000	32.88	8.58	35.70	44.02	49.78	74.00	24.22	Peak
2	4824.000	32.88	8.58	35.70	31.45	37.21	54.00	16.79	Average

Remarks: 1. Emission Level= Antenna Factor + Cable Loss + Reading - Amp Factor
 2. The emission levels that are 20dB below the official limit are not reported.

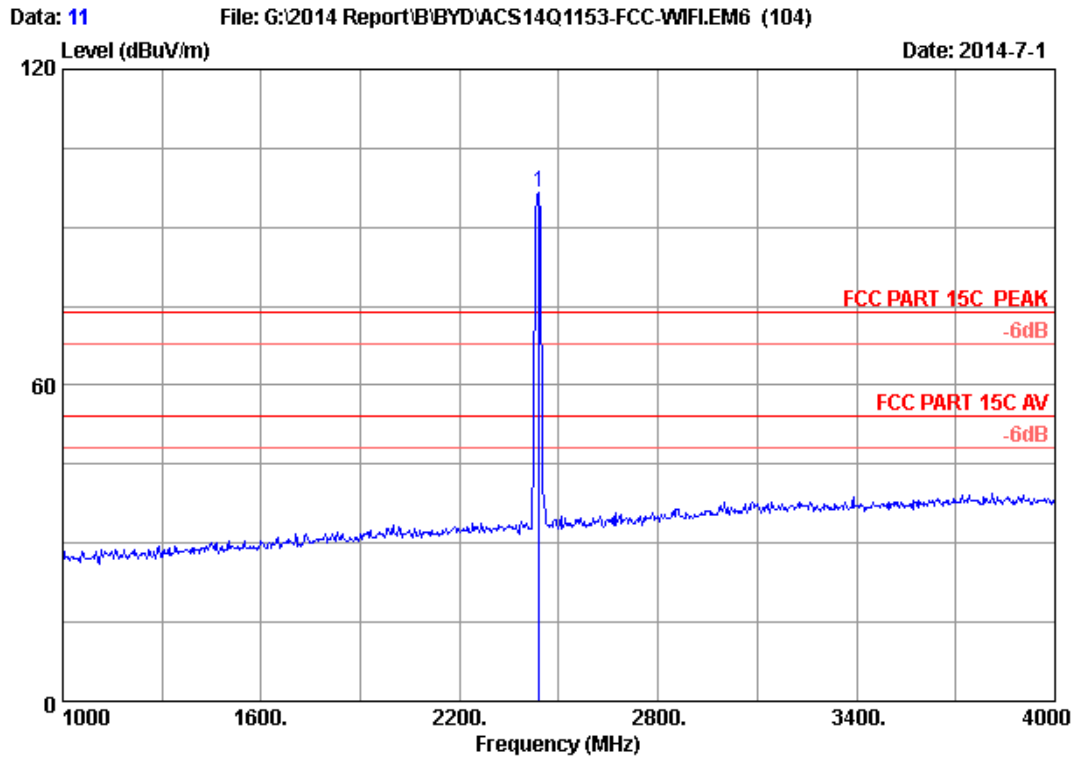

Site no. : 3m Chamber Data no. : 11
 Dis. / Ant. : 3m 2013 3115 (4580) Ant. pol. : VERTICAL
 Limit : FCC PART 15C PEAK
 Env. / Ins. : 24°C/56% Engineer : Kevin_Hu
 EUT : Tablet PC
 Power Rating : DC 5V From Adapter Input AC 120V/60Hz
 Test Mode : IEEE802.11b 2437MHz Tx Mode
 M/N : WT7-C

No.	Freq. (MHz)	Ant. Factor (dB/m)	Cable Loss (dB)	AMP factor (dB)	Reading (dBuV)	Emission			Remark
						Level (dBuV/m)	Limits (dBuV/m)	Margin (dB)	
1	2440.000	28.27	5.86	35.70	98.01	96.44	74.00	-22.44	Peak

Remarks: 1. Emission Level= Antenna Factor + Cable Loss + Reading
 -Amp Factor
 2. The emission levels that are 20dB below the official
 limit are not reported.

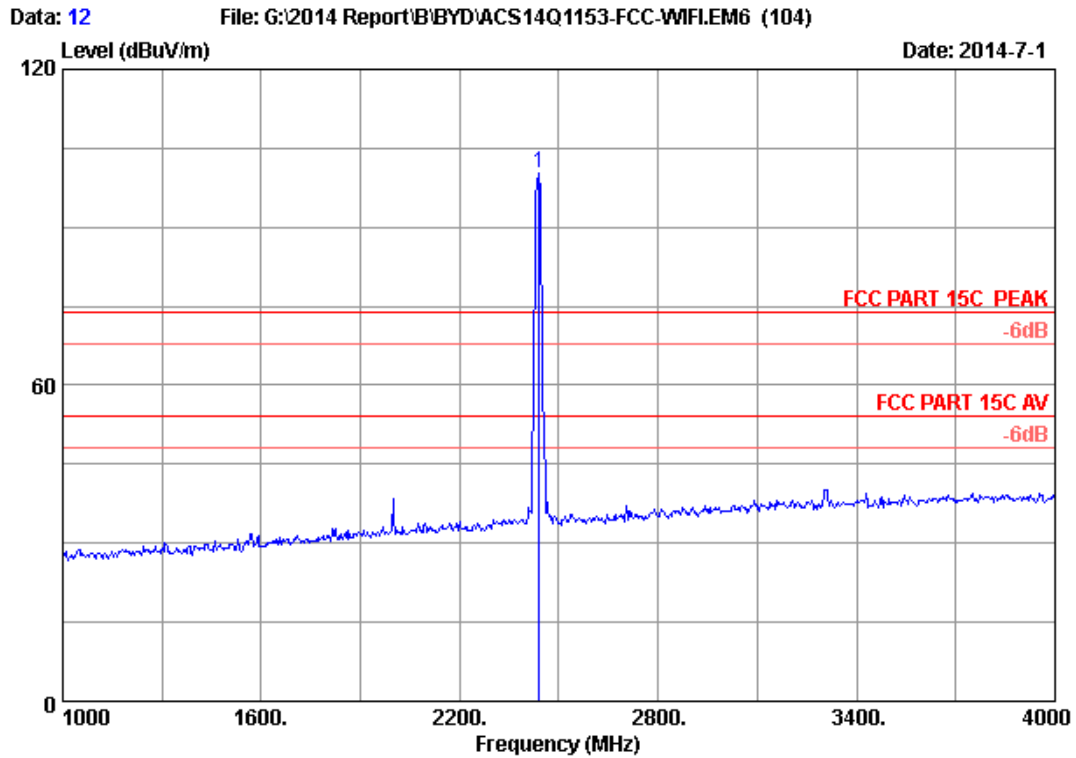

Site no. : 3m Chamber Data no. : 12
 Dis. / Ant. : 3m 2013 3115 (4580) Ant. pol. : HORIZONTAL
 Limit : FCC PART 15C PEAK
 Env. / Ins. : 24°C/56% Engineer : Kevin_Hu
 EUT : Tablet PC
 Power Rating : DC 5V From Adapter Input AC 120V/60Hz
 Test Mode : IEEE802.11b 2437MHz Tx Mode
 M/N : WT7-C

No.	Freq. (MHz)	Ant. Factor (dB/m)	Cable Loss (dB)	AMP factor (dB)	Reading (dBuV)	Emission			Remark
						Level (dBuV/m)	Limits (dBuV/m)	Margin (dB)	
1	2440.000	28.27	5.86	35.70	101.94	100.37	74.00	-26.37	Peak

Remarks: 1. Emission Level= Antenna Factor + Cable Loss + Reading
 -Amp Factor
 2. The emission levels that are 20dB below the official
 limit are not reported.

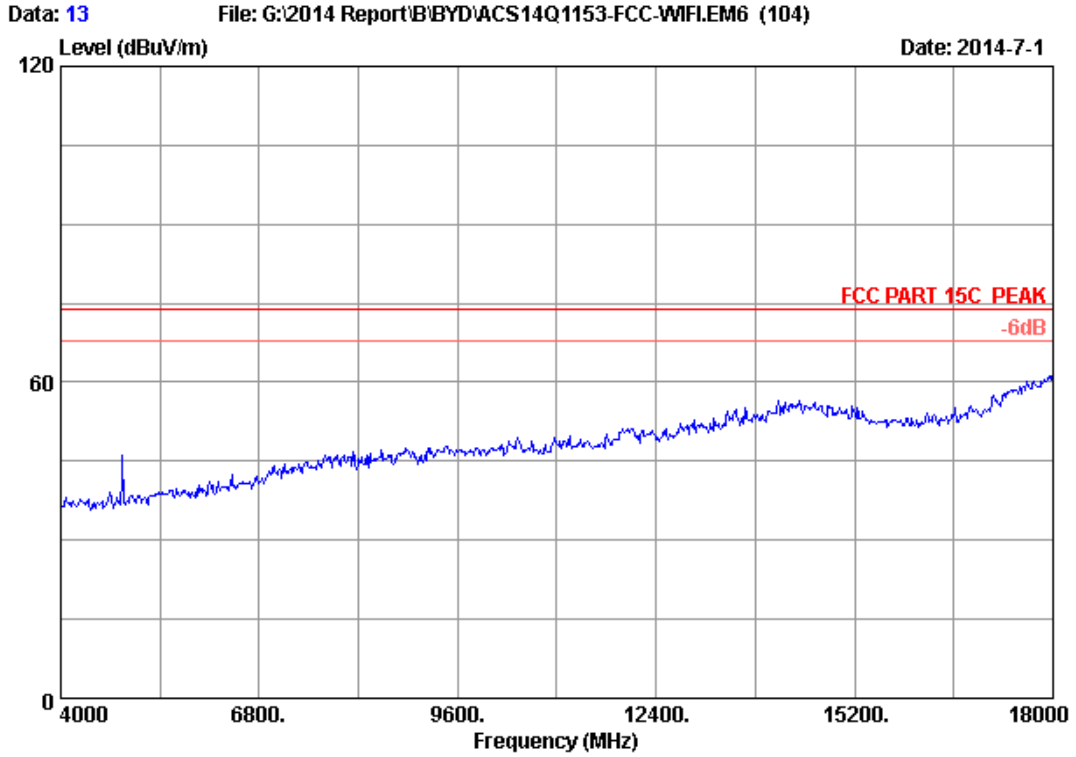

Site no. : 3m Chamber Data no. : 13
Dis. / Ant. : 3m 2013 3115 (4580) Ant. pol. : HORIZONTAL
Limit : FCC PART 15C PEAK
Env. / Ins. : 24°C/56% Engineer : Kevin_Hu
EUT : Tablet PC
Power Rating : DC 5V From Adapter Input AC 120V/60Hz
Test Mode : IEEE802.11b 2437MHz Tx Mode
M/N : WT7-C

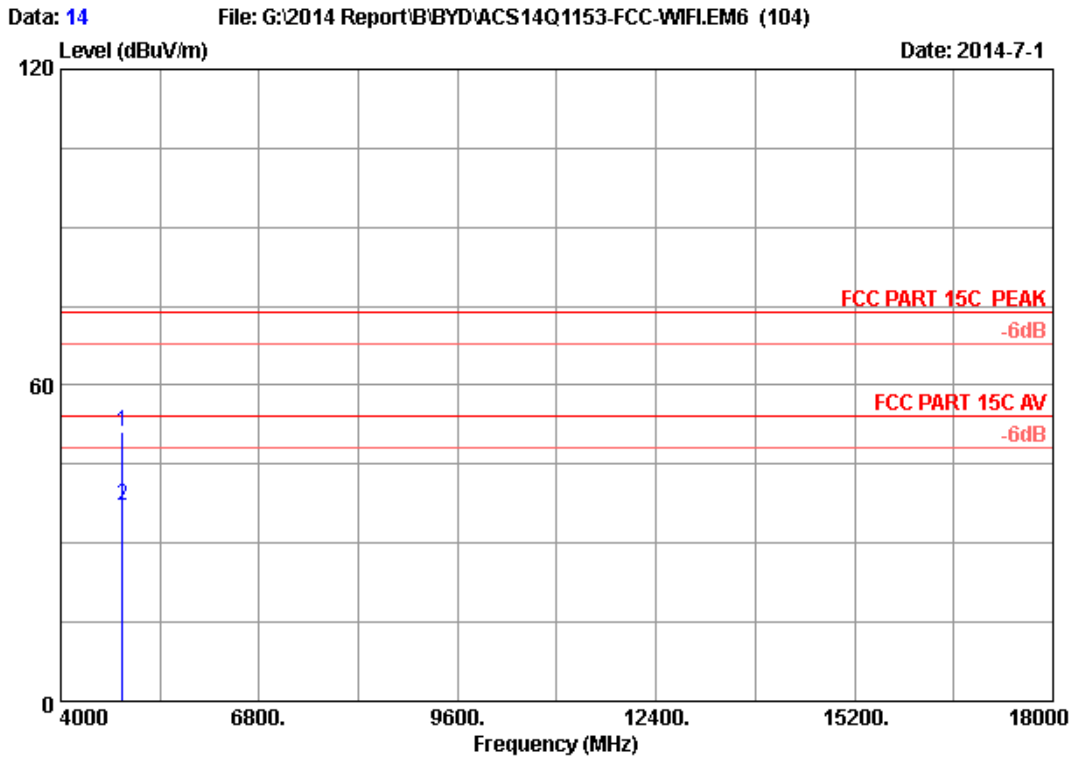

Site no. : 3m Chamber Data no. : 14
 Dis. / Ant. : 3m 2013 3115 (4580) Ant. pol. : HORIZONTAL
 Limit : FCC PART 15C PEAK
 Env. / Ins. : 24°C/56% Engineer : Kevin_Hu
 EUT : Tablet PC
 Power Rating : DC 5V From Adapter Input AC 120V/60Hz
 Test Mode : IEEE802.11b 2437MHz Tx Mode
 M/N : WT7-C

No.	Freq. (MHz)	Ant. Factor (dB/m)	Cable Loss (dB)	AMP factor (dB)	Reading (dBuV)	Emission Level (dBuV/m)	Limits (dBuV/m)	Margin (dB)	Remark
1	4874.000	32.97	8.63	35.70	45.40	51.30	74.00	22.70	Peak
2	4874.000	32.97	8.63	35.70	31.06	36.96	54.00	17.04	Average

Remarks: 1. Emission Level= Antenna Factor + Cable Loss + Reading - Amp Factor
 2. The emission levels that are 20dB below the official limit are not reported.

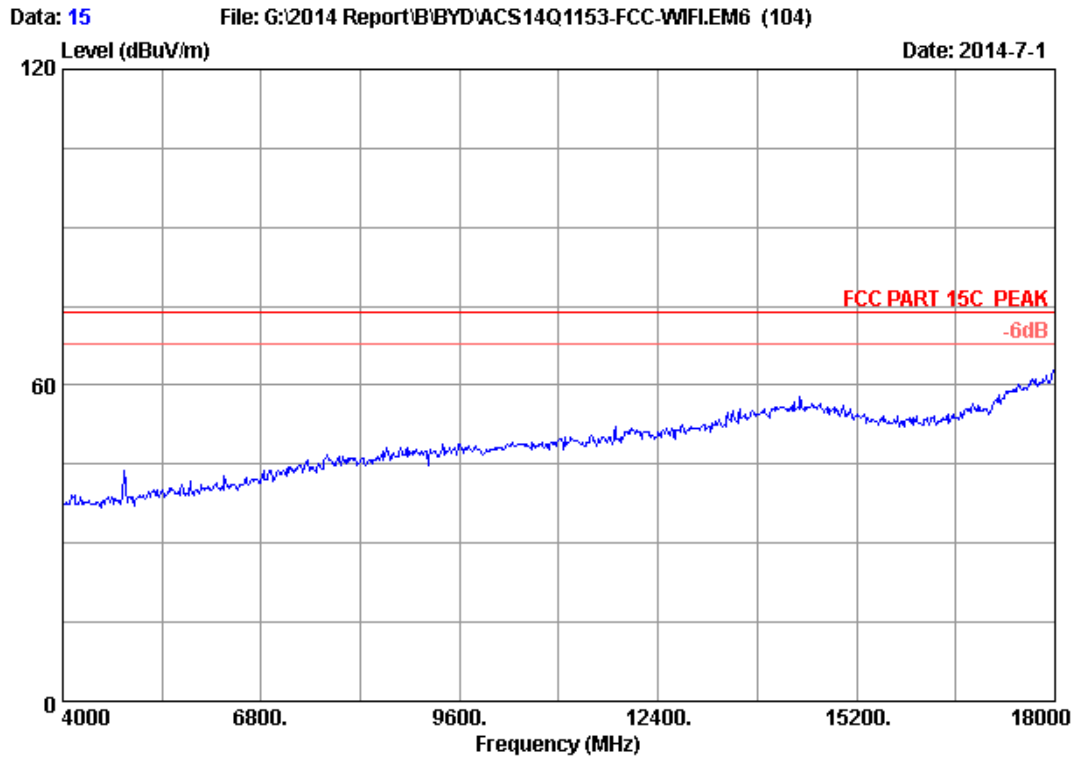

Site no. : 3m Chamber Data no. : 15
Dis. / Ant. : 3m 2013 3115 (4580) Ant. pol. : VERTICAL
Limit : FCC PART 15C PEAK
Env. / Ins. : 24°C/56% Engineer : Kevin_Hu
EUT : Tablet PC
Power Rating : DC 5V From Adapter Input AC 120V/60Hz
Test Mode : IEEE802.11b 2437MHz Tx Mode
M/N : WT7-C

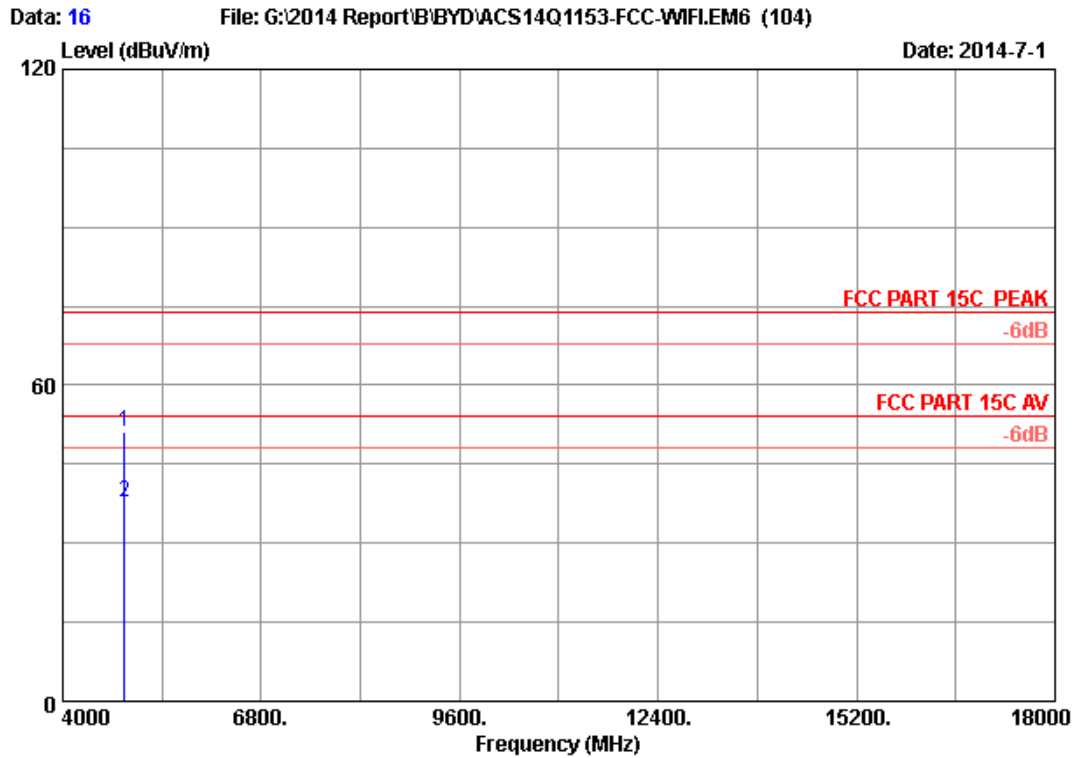

Site no. : 3m Chamber Data no. : 16
 Dis. / Ant. : 3m 2013 3115 (4580) Ant. pol. : VERTICAL
 Limit : FCC PART 15C PEAK
 Env. / Ins. : 24°C/56% Engineer : Kevin_Hu
 EUT : Tablet PC
 Power Rating : DC 5V From Adapter Input AC 120V/60Hz
 Test Mode : IEEE802.11b 2437MHz Tx Mode
 M/N : WT7-C

No.	Freq. (MHz)	Ant. Factor (dB/m)	Cable Loss (dB)	AMP factor (dB)	Reading (dBuV)	Emission			Remark
						Level (dBuV/m)	Limits (dBuV/m)	Margin (dB)	
1	4874.000	32.97	8.63	35.70	45.27	51.17	74.00	22.83	Peak
2	4874.000	32.97	8.63	35.70	31.75	37.65	54.00	16.35	Average

Remarks: 1. Emission Level= Antenna Factor + Cable Loss + Reading - Amp Factor
 2. The emission levels that are 20dB below the official limit are not reported.

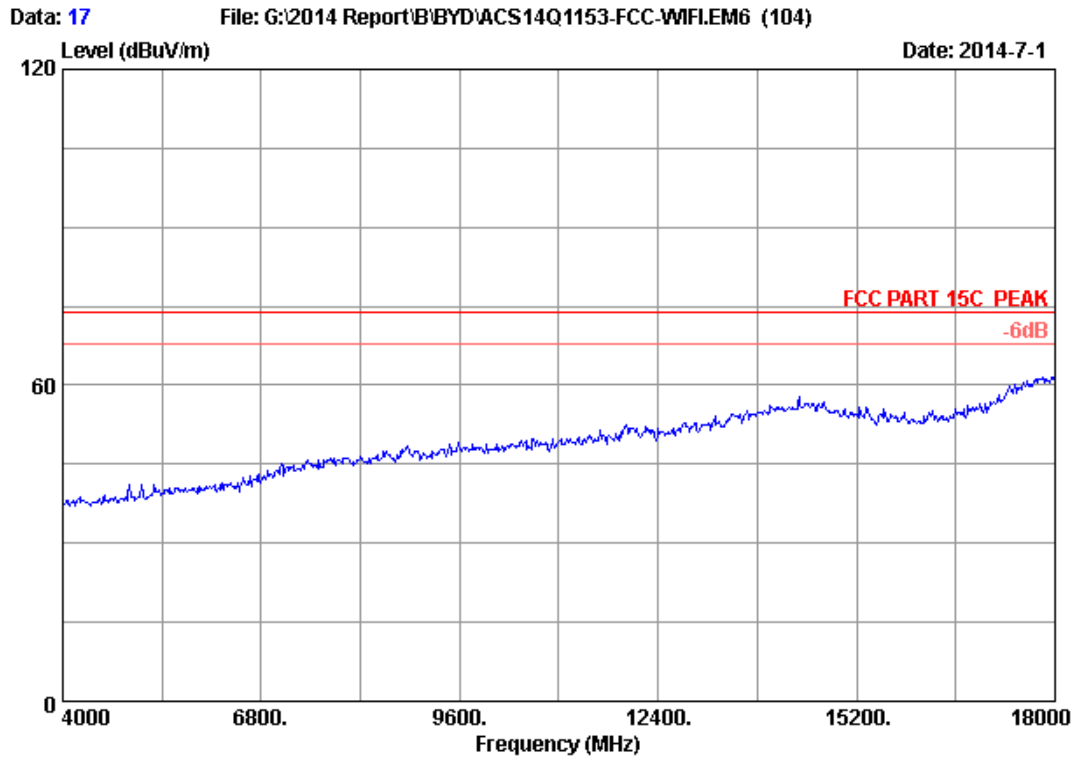

Site no. : 3m Chamber Data no. : 17
Dis. / Ant. : 3m 2013 3115 (4580) Ant. pol. : VERTICAL
Limit : FCC PART 15C PEAK
Env. / Ins. : 24°C/56% Engineer : Kevin_Hu
EUT : Tablet PC
Power Rating : DC 5V From Adapter Input AC 120V/60Hz
Test Mode : IEEE802.11b 2462MHz Tx Mode
M/N : WT7-C

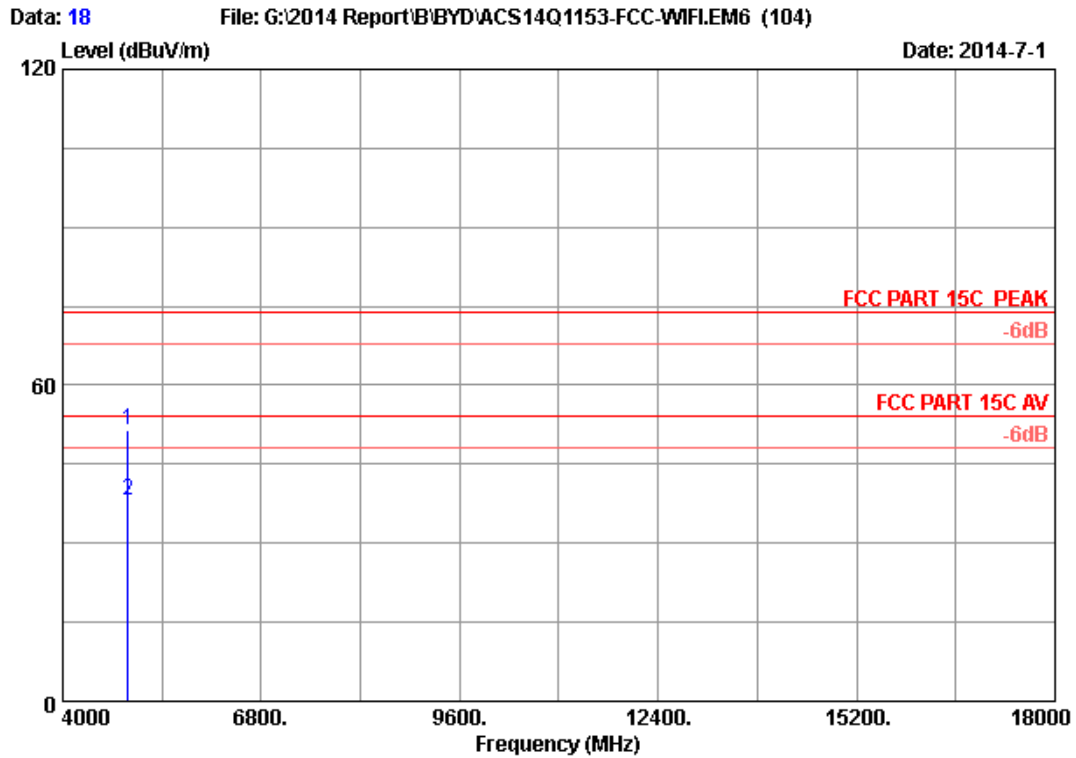

Site no. : 3m Chamber Data no. : 18
 Dis. / Ant. : 3m 2013 3115 (4580) Ant. pol. : VERTICAL
 Limit : FCC PART 15C PEAK
 Env. / Ins. : 24°C/56% Engineer : Kevin_Hu
 EUT : Tablet PC
 Power Rating : DC 5V From Adapter Input AC 120V/60Hz
 Test Mode : IEEE802.11b 2462MHz Tx Mode
 M/N : WT7-C

No.	Freq. (MHz)	Ant. Factor (dB/m)	Cable Loss (dB)	AMP factor (dB)	Reading (dBuV)	Emission Level (dBuV/m)	Limits (dBuV/m)	Margin (dB)	Remark
1	4924.000	33.06	8.69	35.70	45.46	51.51	74.00	22.49	Peak
2	4924.000	33.06	8.69	35.70	32.00	38.05	54.00	15.95	Average

Remarks: 1. Emission Level= Antenna Factor + Cable Loss + Reading - Amp Factor
 2. The emission levels that are 20dB below the official limit are not reported.

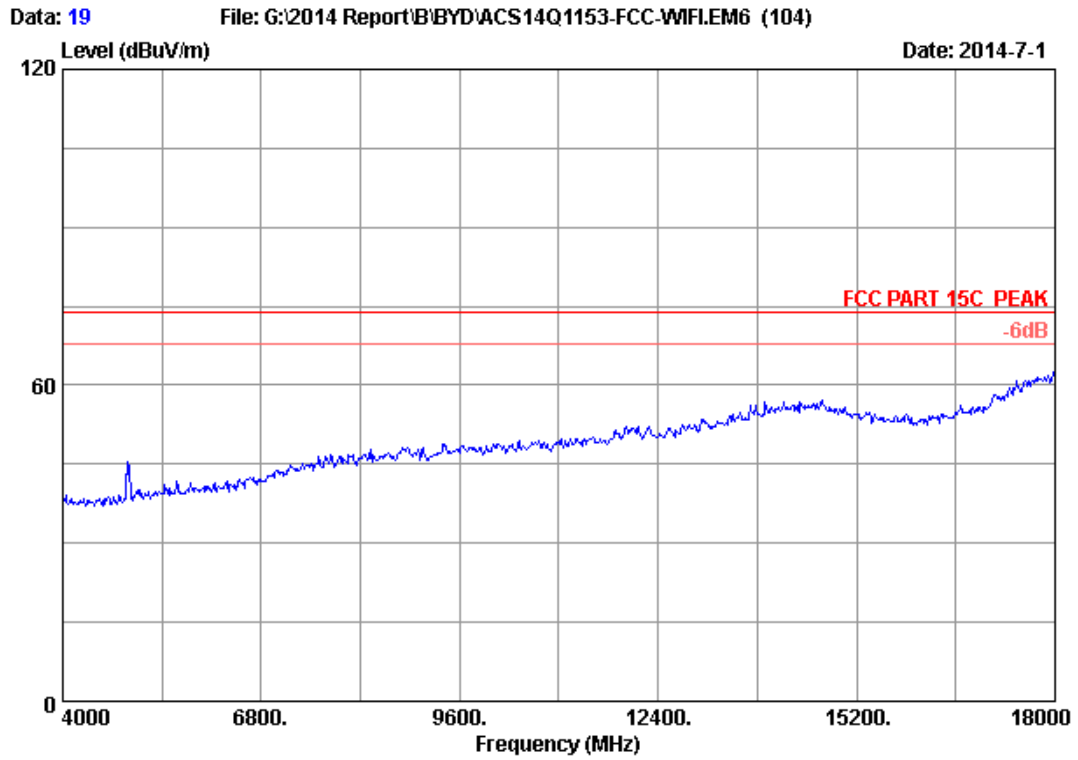

Site no. : 3m Chamber Data no. : 19
Dis. / Ant. : 3m 2013 3115 (4580) Ant. pol. : HORIZONTAL
Limit : FCC PART 15C PEAK
Env. / Ins. : 24°C/56% Engineer : Kevin_Hu
EUT : Tablet PC
Power Rating : DC 5V From Adapter Input AC 120V/60Hz
Test Mode : IEEE802.11b 2462MHz Tx Mode
M/N : WT7-C

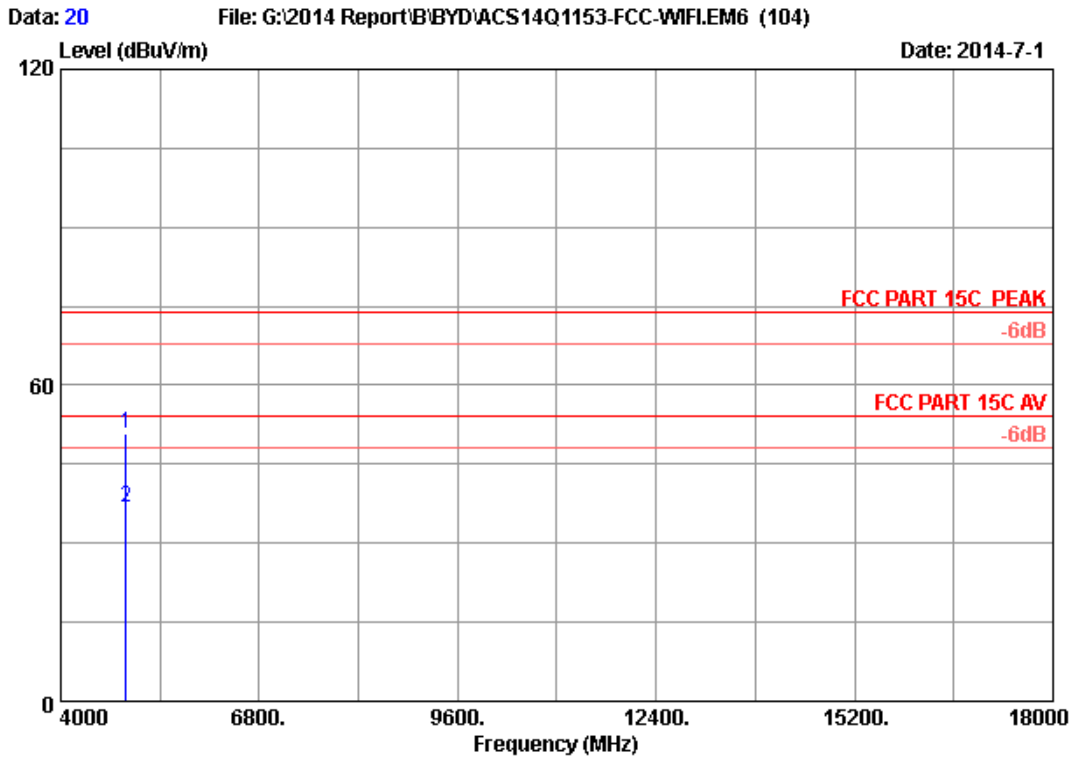

Site no. : 3m Chamber Data no. : 20
 Dis. / Ant. : 3m 2013 3115 (4580) Ant. pol. : HORIZONTAL
 Limit : FCC PART 15C PEAK
 Env. / Ins. : 24°C/56% Engineer : Kevin_Hu
 EUT : Tablet PC
 Power Rating : DC 5V From Adapter Input AC 120V/60Hz
 Test Mode : IEEE802.11b 2462MHz Tx Mode
 M/N : WT7-C

No.	Freq. (MHz)	Ant. Factor (dB/m)	Cable Loss (dB)	AMP factor (dB)	Reading (dBuV)	Emission Level (dBuV/m)	Limits (dBuV/m)	Margin (dB)	Remark
1	4924.000	33.06	8.69	35.70	44.62	50.67	74.00	23.33	Peak
2	4924.000	33.06	8.69	35.70	30.62	36.67	54.00	17.33	Average

Remarks: 1. Emission Level= Antenna Factor + Cable Loss + Reading - Amp Factor
 2. The emission levels that are 20dB below the official limit are not reported.

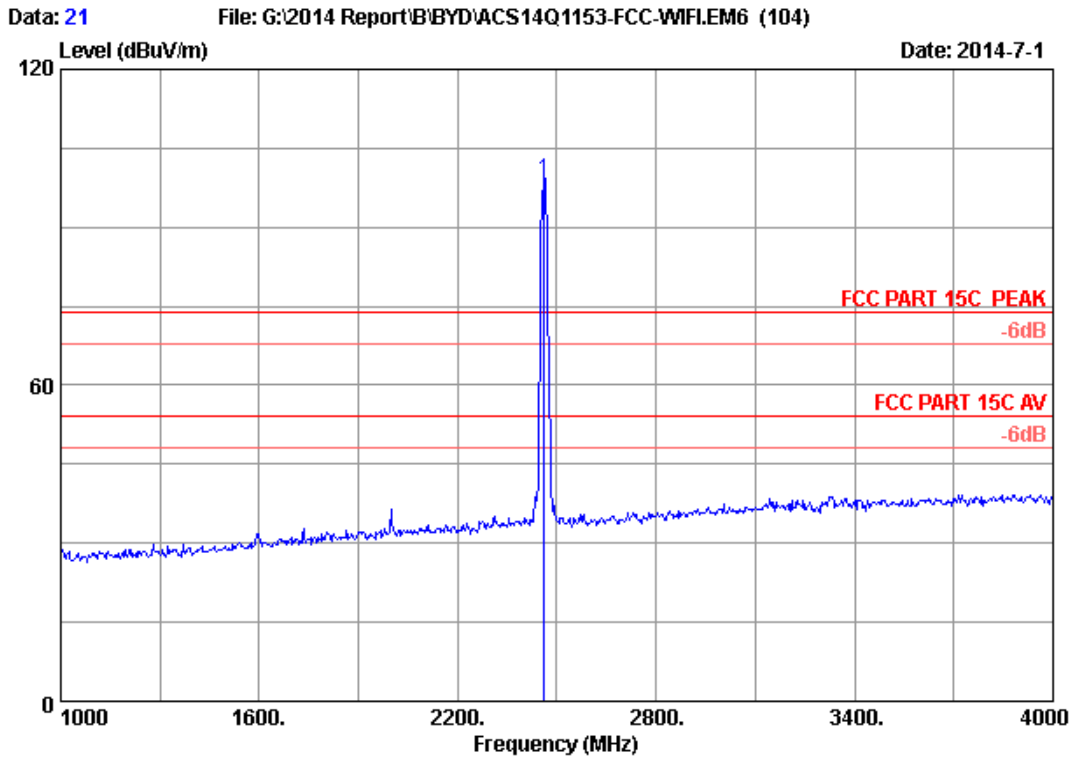

Site no. : 3m Chamber Data no. : 21
 Dis. / Ant. : 3m 2013 3115 (4580) Ant. pol. : HORIZONTAL
 Limit : FCC PART 15C PEAK
 Env. / Ins. : 24°C/56% Engineer : Kevin_Hu
 EUT : Tablet PC
 Power Rating : DC 5V From Adapter Input AC 120V/60Hz
 Test Mode : IEEE802.11b 2462MHz Tx Mode
 M/N : WT7-C

No.	Freq. (MHz)	Ant. Factor (dB/m)	Cable Loss (dB)	AMP factor (dB)	Reading (dBuV)	Emission Level (dBuV/m)	Limits (dBuV/m)	Margin (dB)	Remark
1	2462.000	28.32	5.89	35.70	100.28	98.79	74.00	-24.79	Peak

Remarks: 1. Emission Level= Antenna Factor + Cable Loss + Reading - Amp Factor
 2. The emission levels that are 20dB below the official limit are not reported.

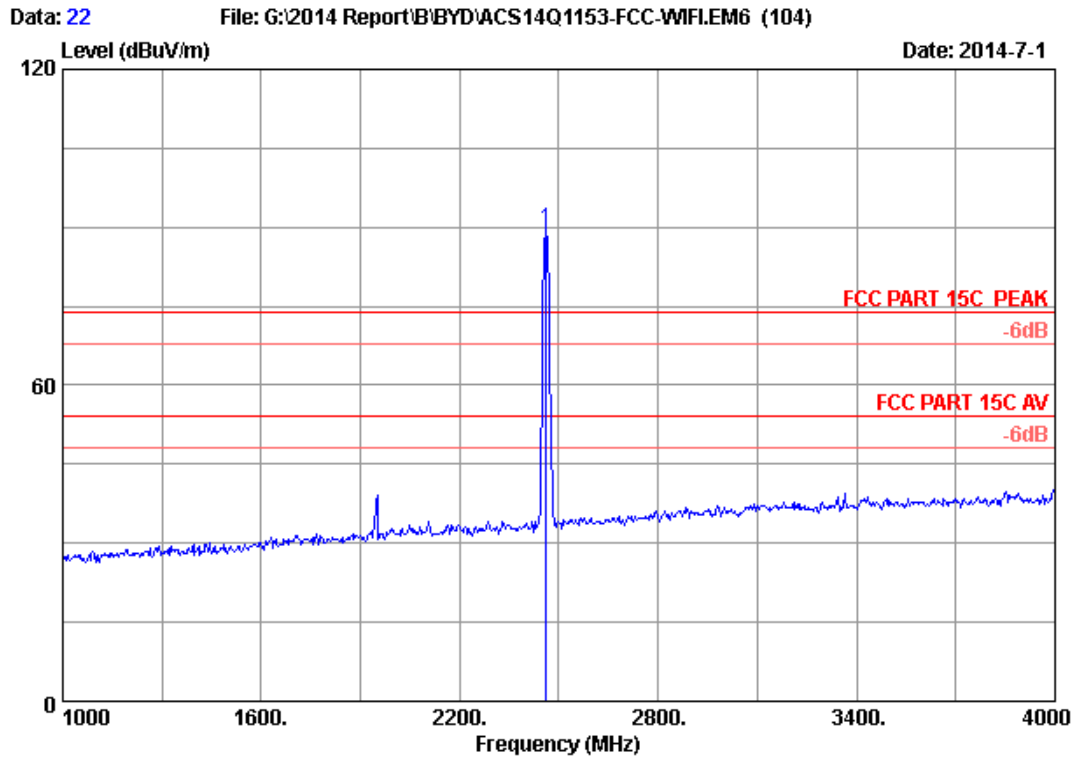

Site no. : 3m Chamber Data no. : 22
 Dis. / Ant. : 3m 2013 3115 (4580) Ant. pol. : VERTICAL
 Limit : FCC PART 15C PEAK
 Env. / Ins. : 24°C/56% Engineer : Kevin_Hu
 EUT : Tablet PC
 Power Rating : DC 5V From Adapter Input AC 120V/60Hz
 Test Mode : IEEE802.11b 2462MHz Tx Mode
 M/N : WT7-C

No.	Freq. (MHz)	Ant. Factor (dB/m)	Cable Loss (dB)	AMP factor (dB)	Reading (dBUV)	Emission			Remark
						Level (dBUV/m)	Limits (dBUV/m)	Margin (dB)	
1	2462.000	28.32	5.89	35.70	90.93	89.44	74.00	-15.44	Peak

Remarks: 1. Emission Level= Antenna Factor + Cable Loss + Reading
 -Amp Factor
 2. The emission levels that are 20dB below the official
 limit are not reported.

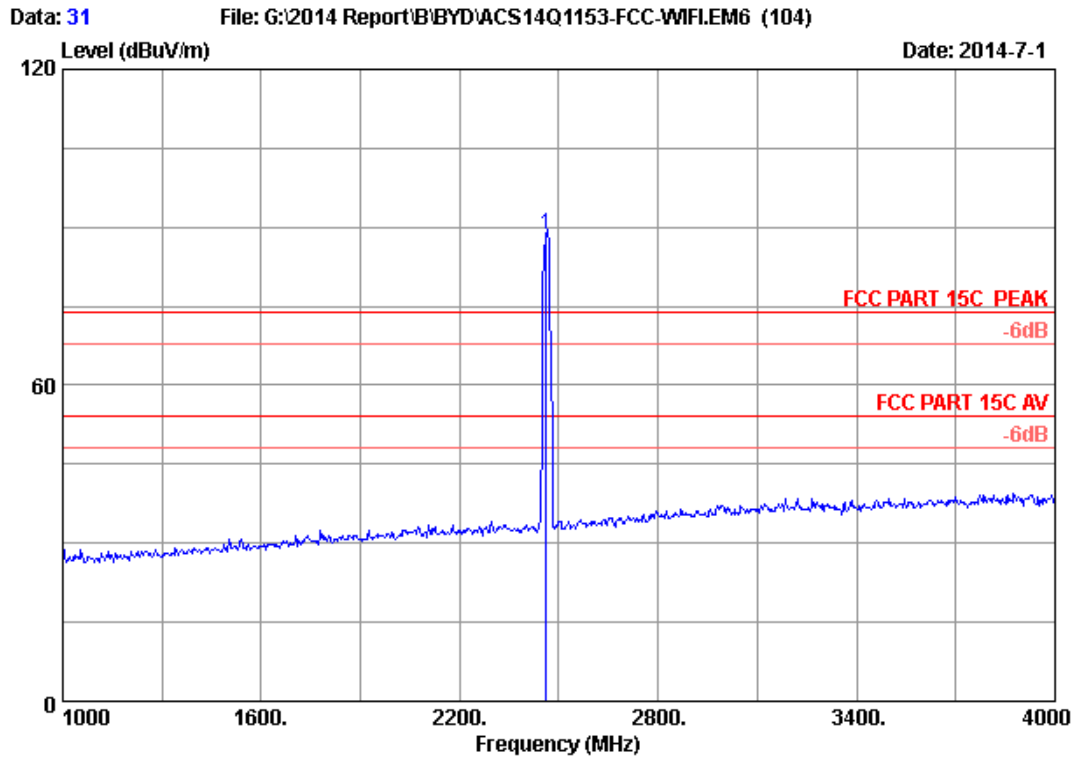

Site no. : 3m Chamber Data no. : 31
 Dis. / Ant. : 3m 2013 3115 (4580) Ant. pol. : VERTICAL
 Limit : FCC PART 15C PEAK
 Env. / Ins. : 24°C/56% Engineer : Kevin_Hu
 EUT : Tablet PC
 Power Rating : DC 5V From Adapter Input AC 120V/60Hz
 Test Mode : IEEE802.11g 2462MHz Tx Mode
 M/N : WT7-C

No.	Freq. (MHz)	Ant. Factor (dB/m)	Cable Loss (dB)	AMP factor (dB)	Reading (dBuV)	Emission			Remark
						Level (dBuV/m)	Limits (dBuV/m)	Margin (dB)	
1	2462.000	28.32	5.89	35.70	90.12	88.63	74.00	-14.63	Peak

Remarks: 1. Emission Level= Antenna Factor + Cable Loss + Reading
 -Amp Factor
 2. The emission levels that are 20dB below the official
 limit are not reported.

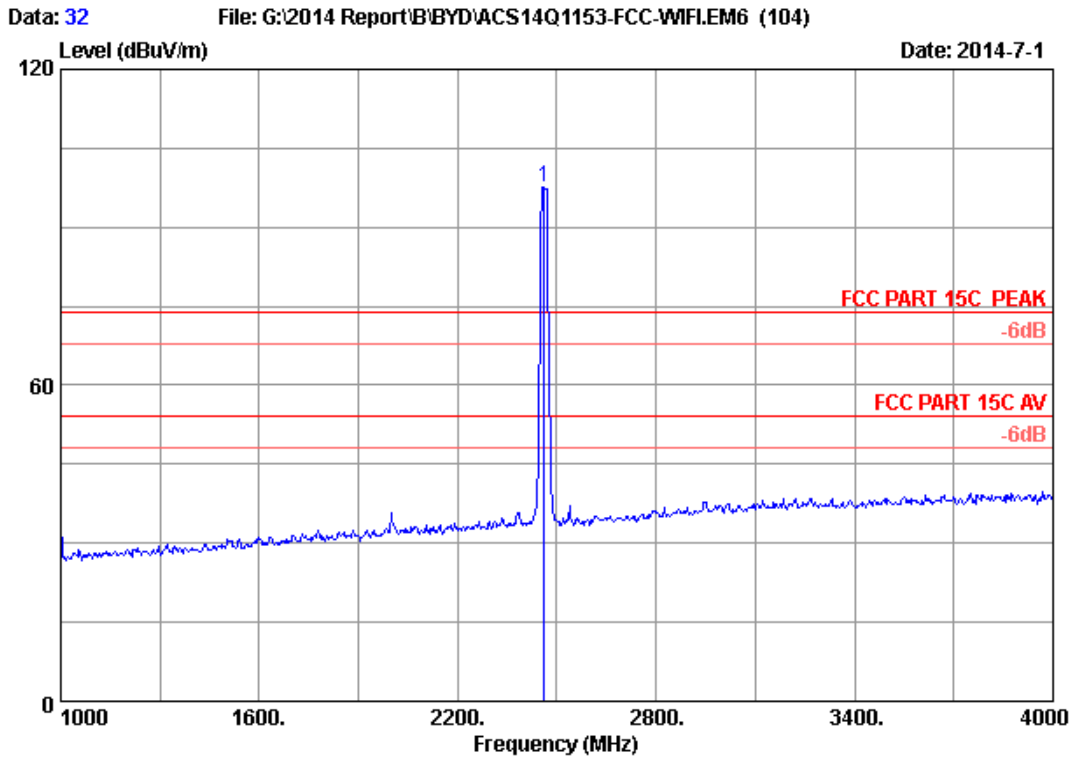

Site no. : 3m Chamber Data no. : 32
 Dis. / Ant. : 3m 2013 3115 (4580) Ant. pol. : HORIZONTAL
 Limit : FCC PART 15C PEAK
 Env. / Ins. : 24°C/56% Engineer : Kevin_Hu
 EUT : Tablet PC
 Power Rating : DC 5V From Adapter Input AC 120V/60Hz
 Test Mode : IEEE802.11g 2462MHz Tx Mode
 M/N : WT7-C

No.	Freq. (MHz)	Ant. Factor (dB/m)	Cable Loss (dB)	AMP factor (dB)	Reading (dBuV)	Emission			Remark
						Level (dBuV/m)	Limits (dBuV/m)	Margin (dB)	
1	2462.000	28.32	5.89	35.70	99.10	97.61	74.00	-23.61	Peak

Remarks: 1. Emission Level= Antenna Factor + Cable Loss + Reading
 -Amp Factor
 2. The emission levels that are 20dB below the official
 limit are not reported.

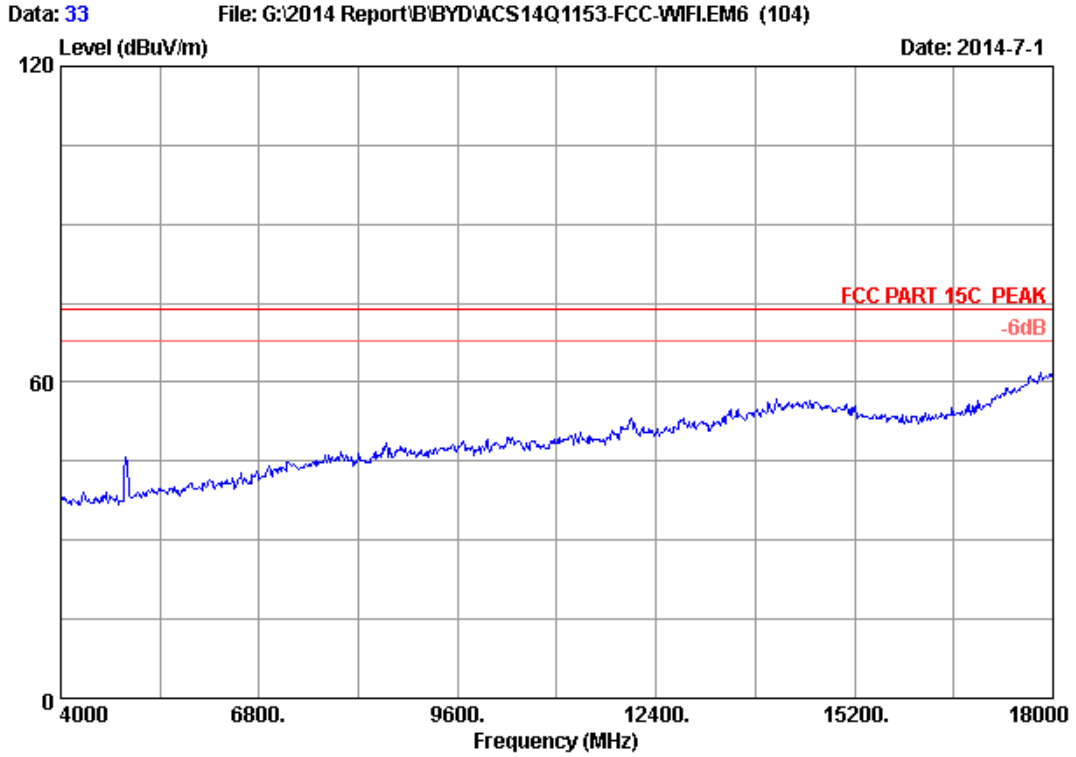

Site no. : 3m Chamber Data no. : 33
Dis. / Ant. : 3m 2013 3115 (4580) Ant. pol. : HORIZONTAL
Limit : FCC PART 15C PEAK
Env. / Ins. : 24°C/56% Engineer : Kevin_Hu
EUT : Tablet PC
Power Rating : DC 5V From Adapter Input AC 120V/60Hz
Test Mode : IEEE802.11g 2462MHz Tx Mode
M/N : WT7-C

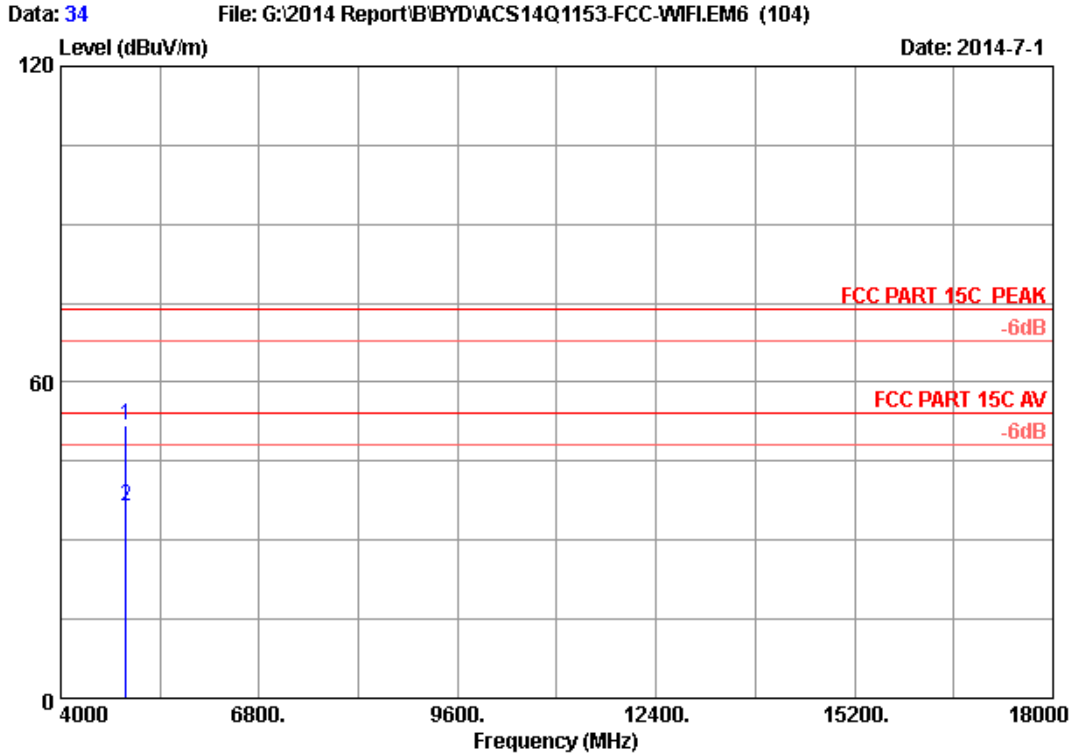

Site no. : 3m Chamber Data no. : 34
 Dis. / Ant. : 3m 2013 3115 (4580) Ant. pol. : HORIZONTAL
 Limit : FCC PART 15C PEAK
 Env. / Ins. : 24°C/56% Engineer : Kevin_Hu
 EUT : Tablet PC
 Power Rating : DC 5V From Adapter Input AC 120V/60Hz
 Test Mode : IEEE802.11g 2462MHz Tx Mode
 M/N : WT7-C

No.	Freq. (MHz)	Ant. Factor (dB/m)	Cable Loss (dB)	AMP factor (dB)	Reading (dBuV)	Emission Level (dBuV/m)	Limits (dBuV/m)	Margin (dB)	Remark
1	4924.000	33.06	8.69	35.70	45.72	51.77	74.00	22.23	Peak
2	4924.000	33.06	8.69	35.70	30.41	36.46	54.00	17.54	Average

Remarks: 1. Emission Level= Antenna Factor + Cable Loss + Reading - Amp Factor
 2. The emission levels that are 20dB below the official limit are not reported.

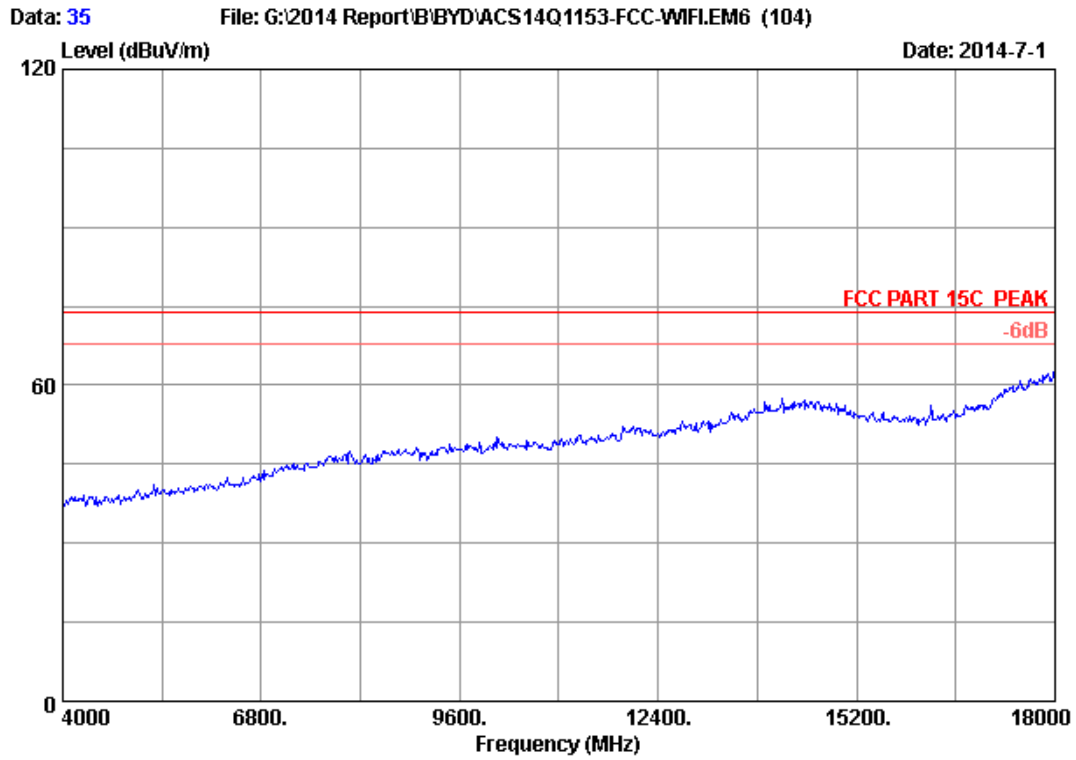

Site no. : 3m Chamber Data no. : 35
Dis. / Ant. : 3m 2013 3115 (4580) Ant. pol. : VERTICAL
Limit : FCC PART 15C PEAK
Env. / Ins. : 24°C/56% Engineer : Kevin_Hu
EUT : Tablet PC
Power Rating : DC 5V From Adapter Input AC 120V/60Hz
Test Mode : IEEE802.11g 2462MHz Tx Mode
M/N : WT7-C

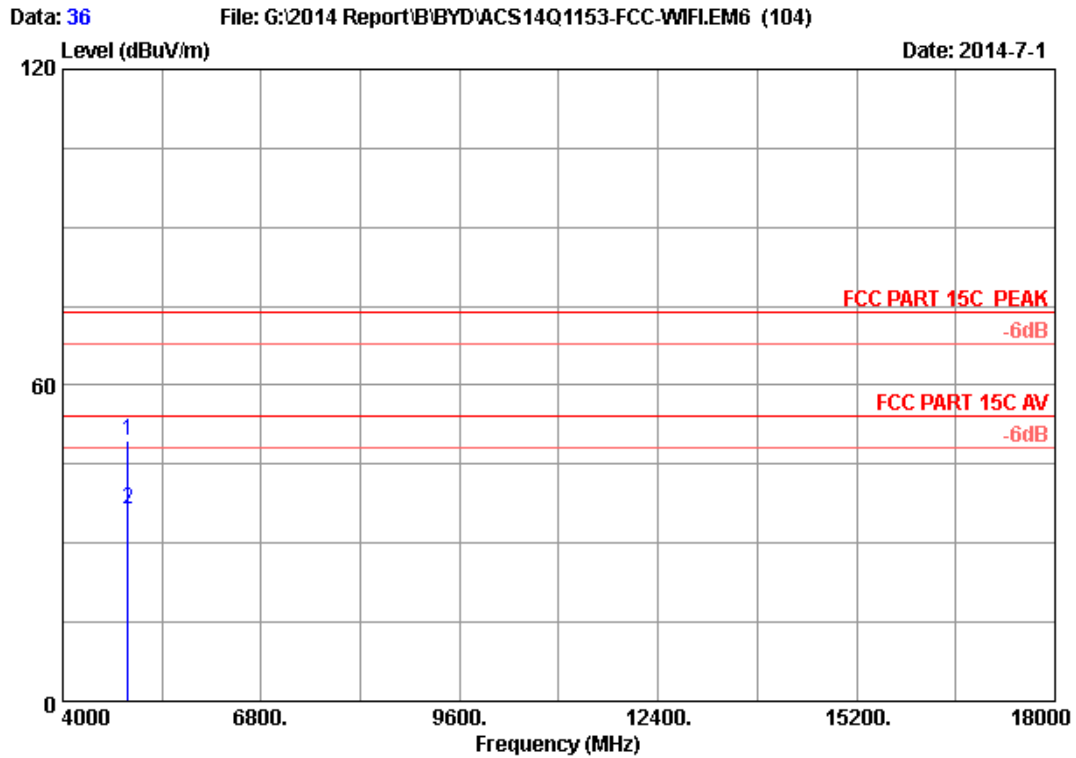

Site no. : 3m Chamber Data no. : 36
 Dis. / Ant. : 3m 2013 3115 (4580) Ant. pol. : VERTICAL
 Limit : FCC PART 15C PEAK
 Env. / Ins. : 24*C/56% Engineer : Kevin_Hu
 EUT : Tablet PC
 Power Rating : DC 5V From Adapter Input AC 120V/60Hz
 Test Mode : IEEE802.11g 2462MHz Tx Mode
 M/N : WT7-C

No.	Freq. (MHz)	Ant. Factor (dB/m)	Cable Loss (dB)	AMP factor (dB)	Reading (dBuV)	Emission Level (dBuV/m)	Limits (dBuV/m)	Margin (dB)	Remark
1	4924.000	33.06	8.69	35.70	43.53	49.58	74.00	24.42	Peak
2	4924.000	33.06	8.69	35.70	30.37	36.42	54.00	17.58	Average

Remarks: 1. Emission Level= Antenna Factor + Cable Loss + Reading - Amp Factor
 2. The emission levels that are 20dB below the official limit are not reported.

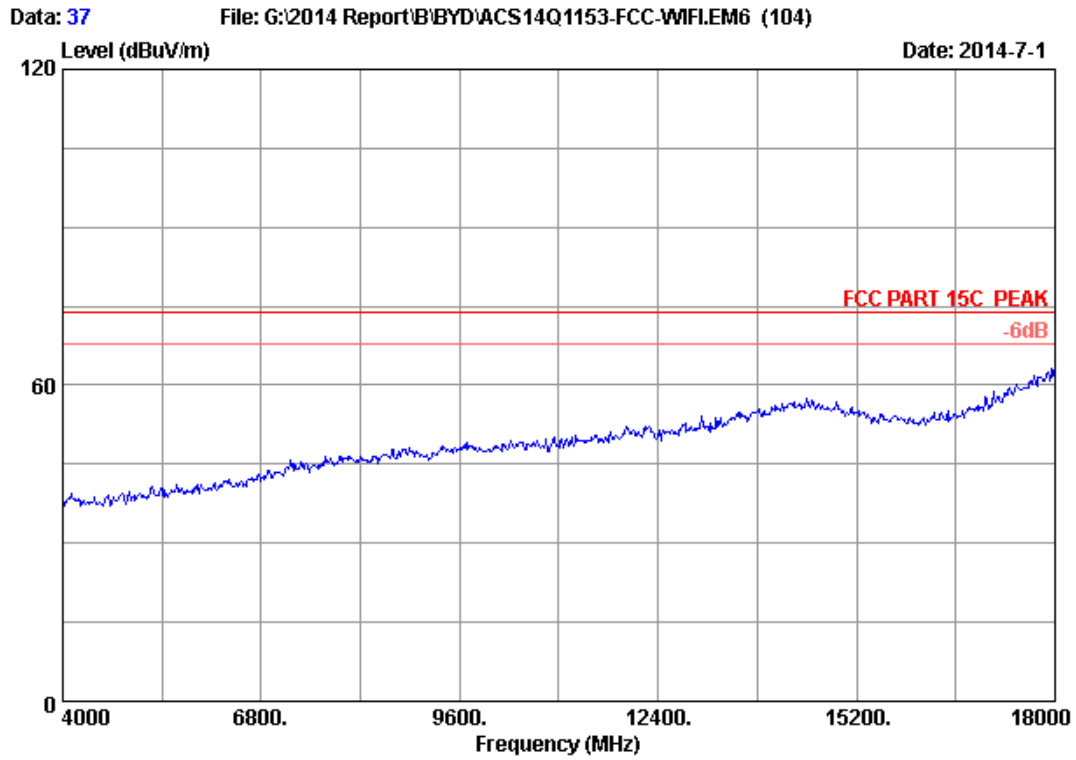

Site no. : 3m Chamber Data no. : 37
Dis. / Ant. : 3m 2013 3115 (4580) Ant. pol. : VERTICAL
Limit : FCC PART 15C PEAK
Env. / Ins. : 24°C/56% Engineer : Kevin_Hu
EUT : Tablet PC
Power Rating : DC 5V From Adapter Input AC 120V/60Hz
Test Mode : IEEE802.11g 2437MHz Tx Mode
M/N : WT7-C

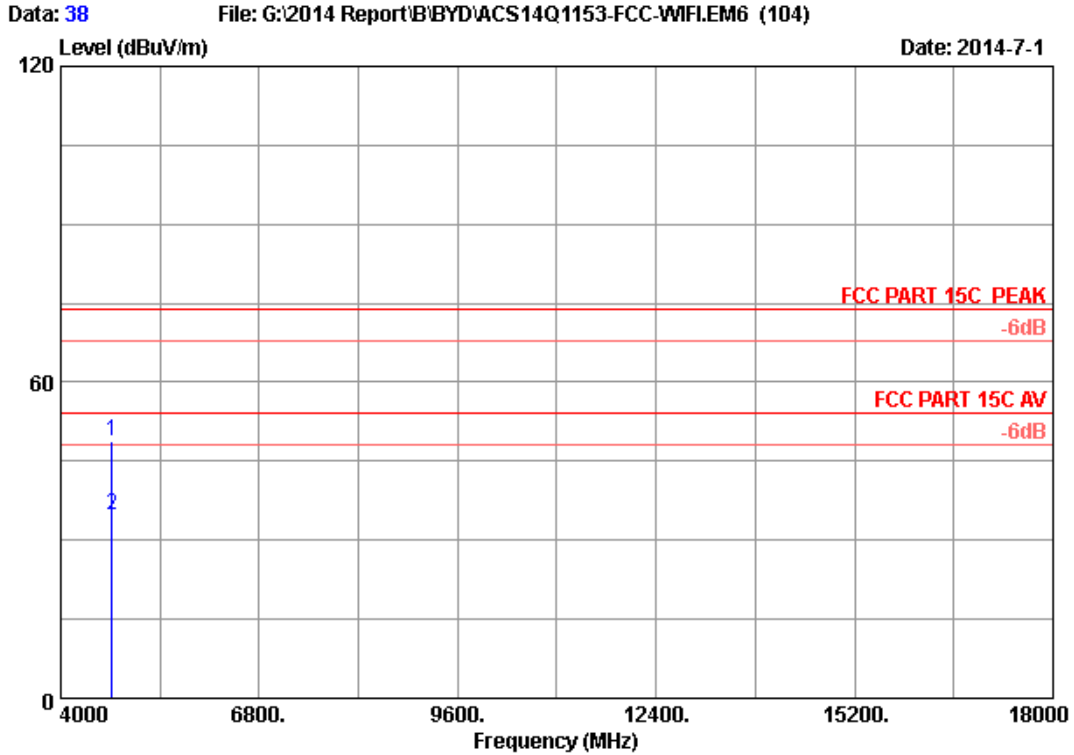

Site no. : 3m Chamber Data no. : 38
 Dis. / Ant. : 3m 2013 3115 (4580) Ant. pol. : VERTICAL
 Limit : FCC PART 15C PEAK
 Env. / Ins. : 24°C/56% Engineer : Kevin_Hu
 EUT : Tablet PC
 Power Rating : DC 5V From Adapter Input AC 120V/60Hz
 Test Mode : IEEE802.11g 2437MHz Tx Mode
 M/N : WT7-C

No.	Freq. (MHz)	Ant. Factor (dB/m)	Cable Loss (dB)	AMP factor (dB)	Reading (dBuV)	Emission Level (dBuV/m)	Limits (dBuV/m)	Margin (dB)	Remark
1	4724.000	32.70	8.48	35.70	43.19	48.67	74.00	25.33	Peak
2	4724.000	32.70	8.48	35.70	29.41	34.89	54.00	19.11	Average

Remarks: 1. Emission Level= Antenna Factor + Cable Loss + Reading - Amp Factor
 2. The emission levels that are 20dB below the official limit are not reported.

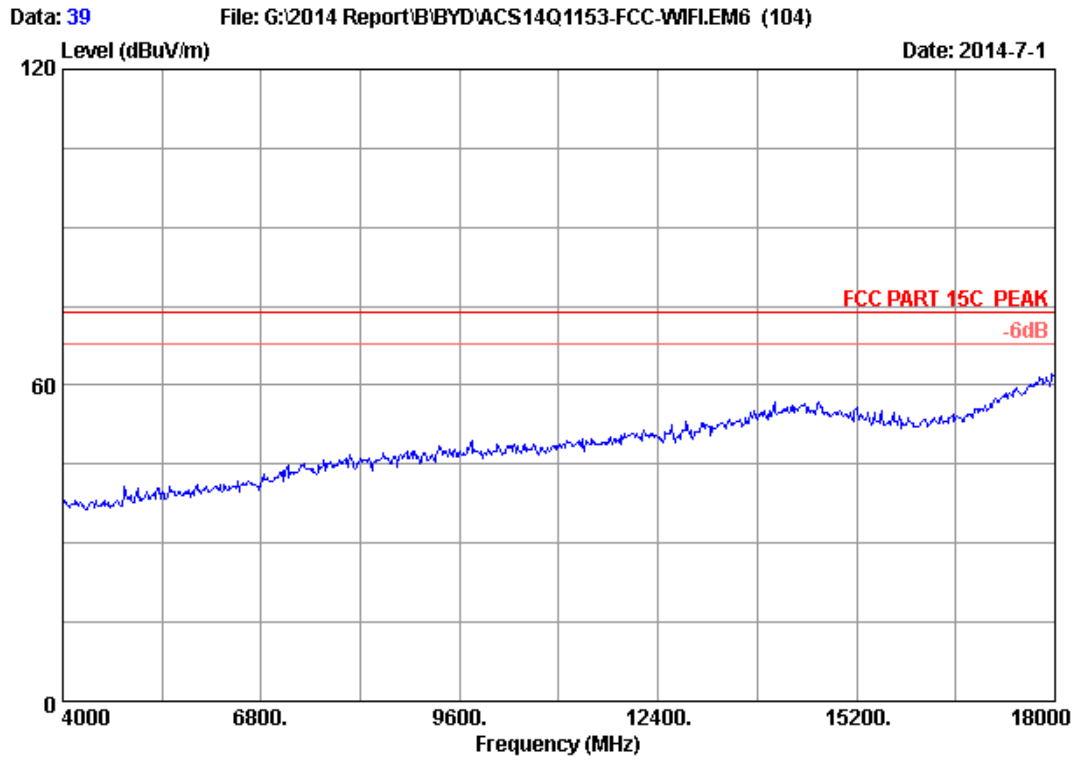

Site no. : 3m Chamber Data no. : 39
Dis. / Ant. : 3m 2013 3115 (4580) Ant. pol. : HORIZONTAL
Limit : FCC PART 15C PEAK
Env. / Ins. : 24°C/56% Engineer : Kevin_Hu
EUT : Tablet PC
Power Rating : DC 5V From Adapter Input AC 120V/60Hz
Test Mode : IEEE802.11g 2437MHz Tx Mode
M/N : WT7-C

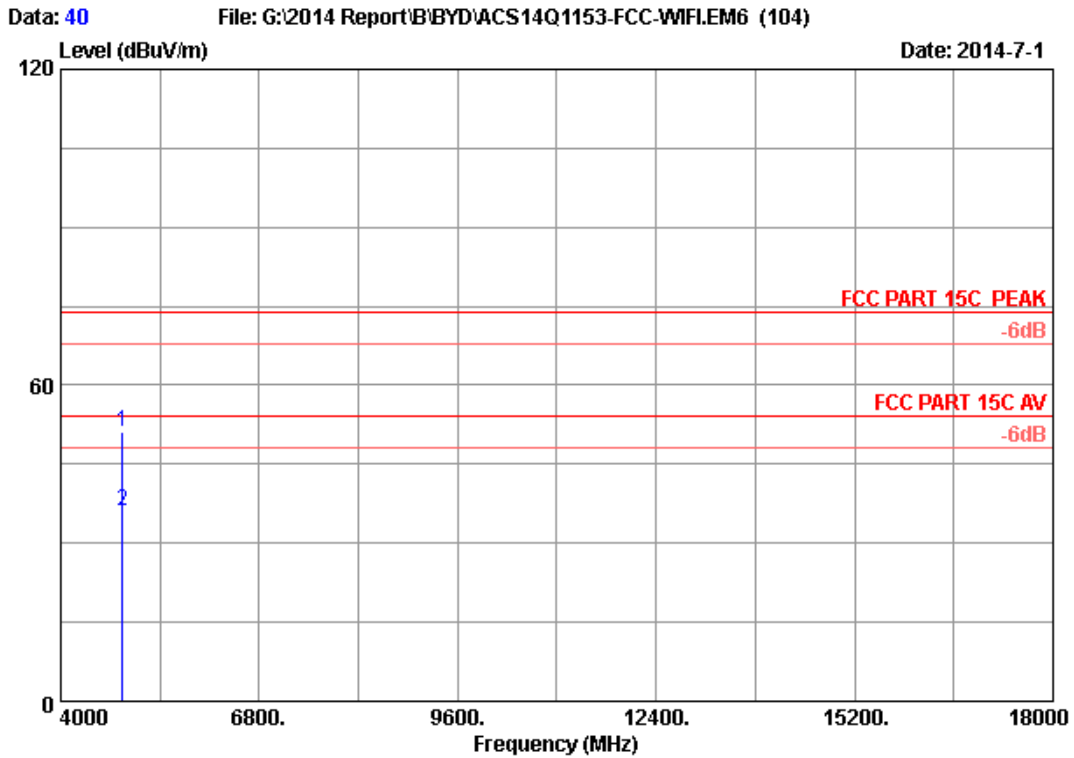

Site no. : 3m Chamber Data no. : 40
 Dis. / Ant. : 3m 2013 3115 (4580) Ant. pol. : HORIZONTAL
 Limit : FCC PART 15C PEAK
 Env. / Ins. : 24°C/56% Engineer : Kevin_Hu
 EUT : Tablet PC
 Power Rating : DC 5V From Adapter Input AC 120V/60Hz
 Test Mode : IEEE802.11g 2437MHz Tx Mode
 M/N : WT7-C

No.	Freq. (MHz)	Ant. Factor (dB/m)	Cable Loss (dB)	AMP factor (dB)	Reading (dBuV)	Emission Level (dBuV/m)	Limits (dBuV/m)	Margin (dB)	Remark
1	4874.000	32.97	8.63	35.70	45.27	51.17	74.00	22.83	Peak
2	4874.000	32.97	8.63	35.70	30.09	35.99	54.00	18.01	Average

Remarks: 1. Emission Level= Antenna Factor + Cable Loss + Reading - Amp Factor
 2. The emission levels that are 20dB below the official limit are not reported.

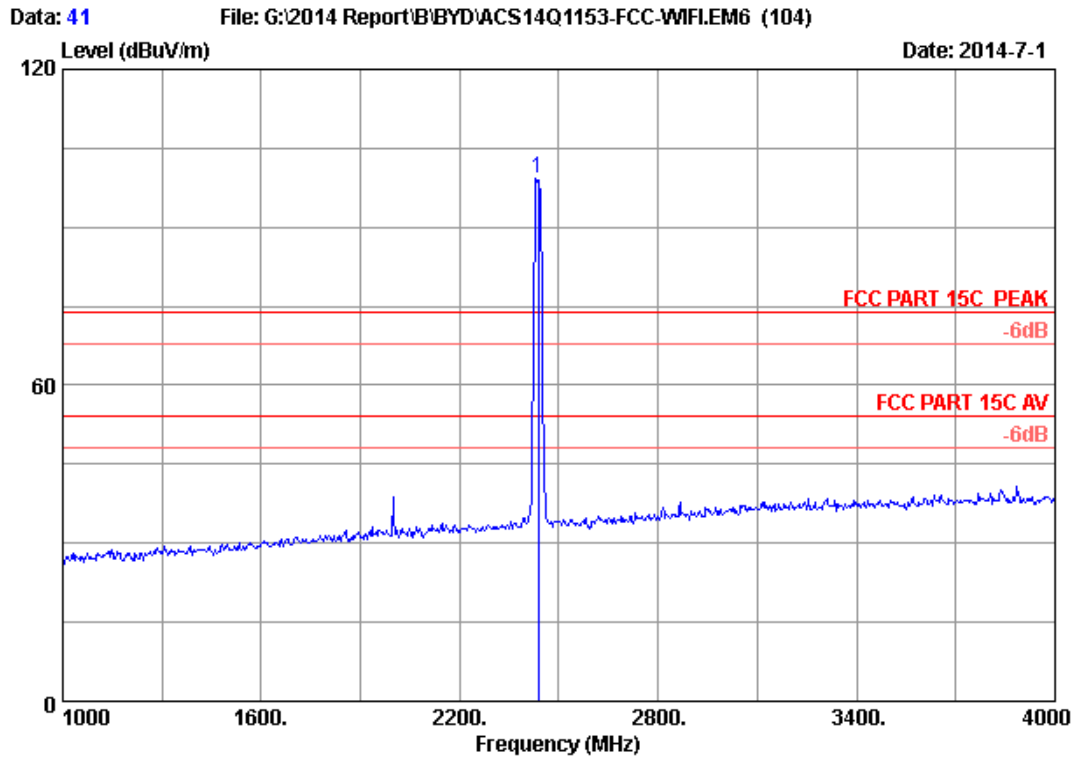

Site no. : 3m Chamber Data no. : 41
 Dis. / Ant. : 3m 2013 3115 (4580) Ant. pol. : HORIZONTAL
 Limit : FCC PART 15C PEAK
 Env. / Ins. : 24°C/56% Engineer : Kevin_Hu
 EUT : Tablet PC
 Power Rating : DC 5V From Adapter Input AC 120V/60Hz
 Test Mode : IEEE802.11g 2437MHz Tx Mode
 M/N : WT7-C

No.	Freq. (MHz)	Ant. Factor (dB/m)	Cable Loss (dB)	AMP factor (dB)	Reading (dBUV)	Emission			Remark
						Level (dBUV/m)	Limits (dBUV/m)	Margin (dB)	
1	2437.000	28.26	5.85	35.70	100.92	99.33	74.00	-25.33	Peak

Remarks: 1. Emission Level= Antenna Factor + Cable Loss + Reading
 -Amp Factor

2. The emission levels that are 20dB below the official
 limit are not reported.

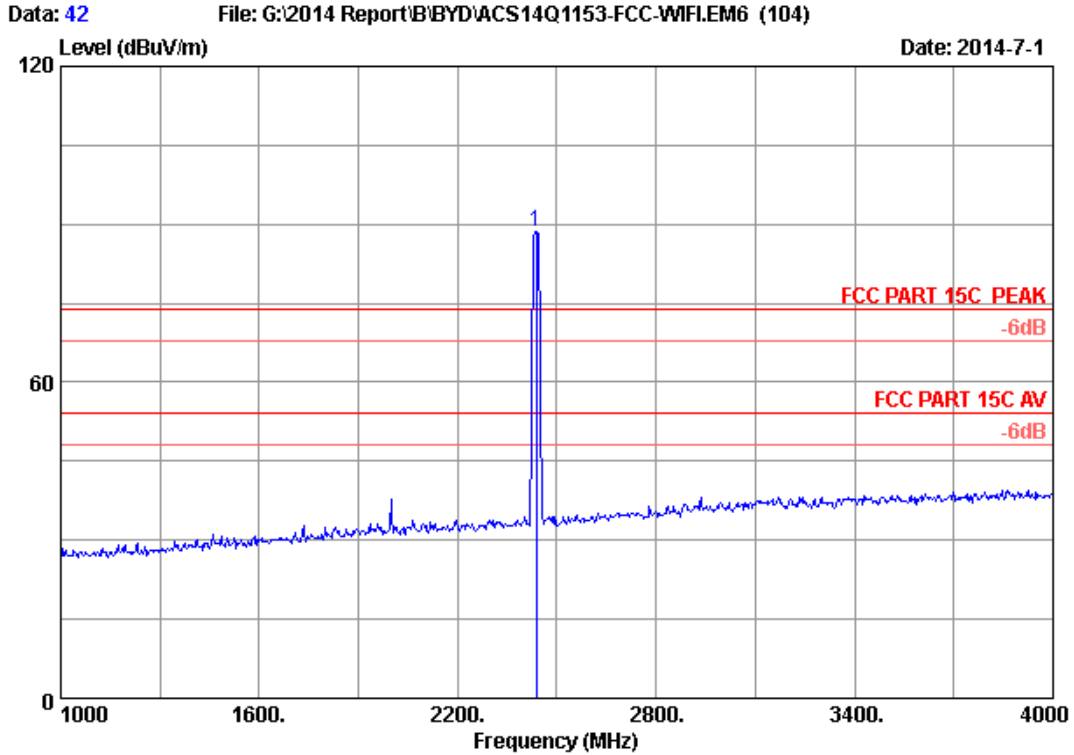

Site no. : 3m Chamber Data no. : 42
 Dis. / Ant. : 3m 2013 3115 (4580) Ant. pol. : VERTICAL
 Limit : FCC PART 15C PEAK
 Env. / Ins. : 24°C/56% Engineer : Kevin_Hu
 EUT : Tablet PC
 Power Rating : DC 5V From Adapter Input AC 120V/60Hz
 Test Mode : IEEE802.11g 2437MHz Tx Mode
 M/N : WT7-C

No.	Freq. (MHz)	Ant. Factor (dB/m)	Cable Loss (dB)	AMP factor (dB)	Reading (dBuV)	Emission			Remark
						Level (dBuV/m)	Limits (dBuV/m)	Margin (dB)	
1	2437.000	28.26	5.85	35.70	90.14	88.55	74.00	-14.55	Peak

Remarks: 1. Emission Level= Antenna Factor + Cable Loss + Reading
 -Amp Factor
 2. The emission levels that are 20dB below the official
 limit are not reported.

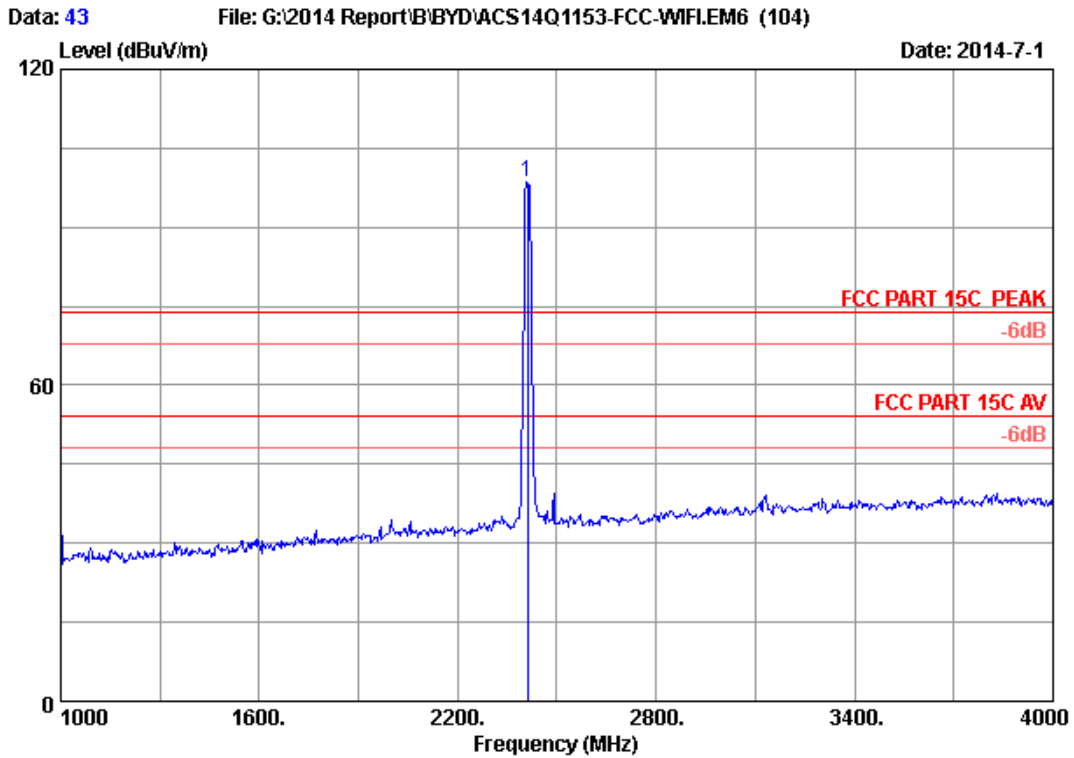

Site no. : 3m Chamber Data no. : 43
 Dis. / Ant. : 3m 2013 3115 (4580) Ant. pol. : HORIZONTAL
 Limit : FCC PART 15C PEAK
 Env. / Ins. : 24°C/56% Engineer : Kevin_Hu
 EUT : Tablet PC
 Power Rating : DC 5V From Adapter Input AC 120V/60Hz
 Test Mode : IEEE802.11g 2412MHz Tx Mode
 M/N : WT7-C

No.	Freq. (MHz)	Ant. Factor (dB/m)	Cable Loss (dB)	AMP factor (dB)	Reading (dBUV)	Emission Level (dBUV/m)	Limits (dBUV/m)	Margin (dB)	Remark
1	2412.000	28.21	5.81	35.70	100.25	98.57	74.00	-24.57	Peak

Remarks: 1. Emission Level= Antenna Factor + Cable Loss + Reading - Amp Factor
 2. The emission levels that are 20dB below the official limit are not reported.

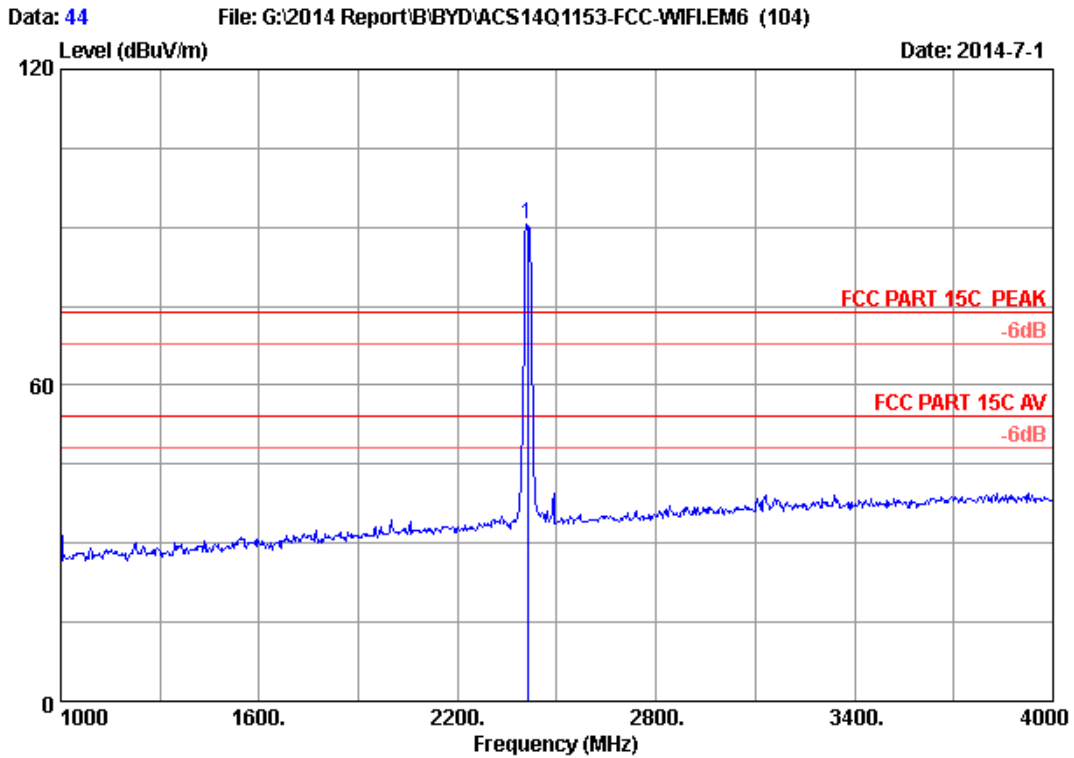

Site no. : 3m Chamber Data no. : 44
 Dis. / Ant. : 3m 2013 3115 (4580) Ant. pol. : VERTICAL
 Limit : FCC PART 15C PEAK
 Env. / Ins. : 24°C/56% Engineer : Kevin_Hu
 EUT : Tablet PC
 Power Rating : DC 5V From Adapter Input AC 120V/60Hz
 Test Mode : IEEE802.11g 2412MHz Tx Mode
 M/N : WT7-C

No.	Freq. (MHz)	Ant. Factor (dB/m)	Cable Loss (dB)	AMP factor (dB)	Reading (dBuV)	Emission			Remark
						Level (dBuV/m)	Limits (dBuV/m)	Margin (dB)	
1	2412.000	28.21	5.81	35.70	92.25	90.57	74.00	-16.57	Peak

Remarks: 1. Emission Level= Antenna Factor + Cable Loss + Reading
 -Amp Factor
 2. The emission levels that are 20dB below the official
 limit are not reported.

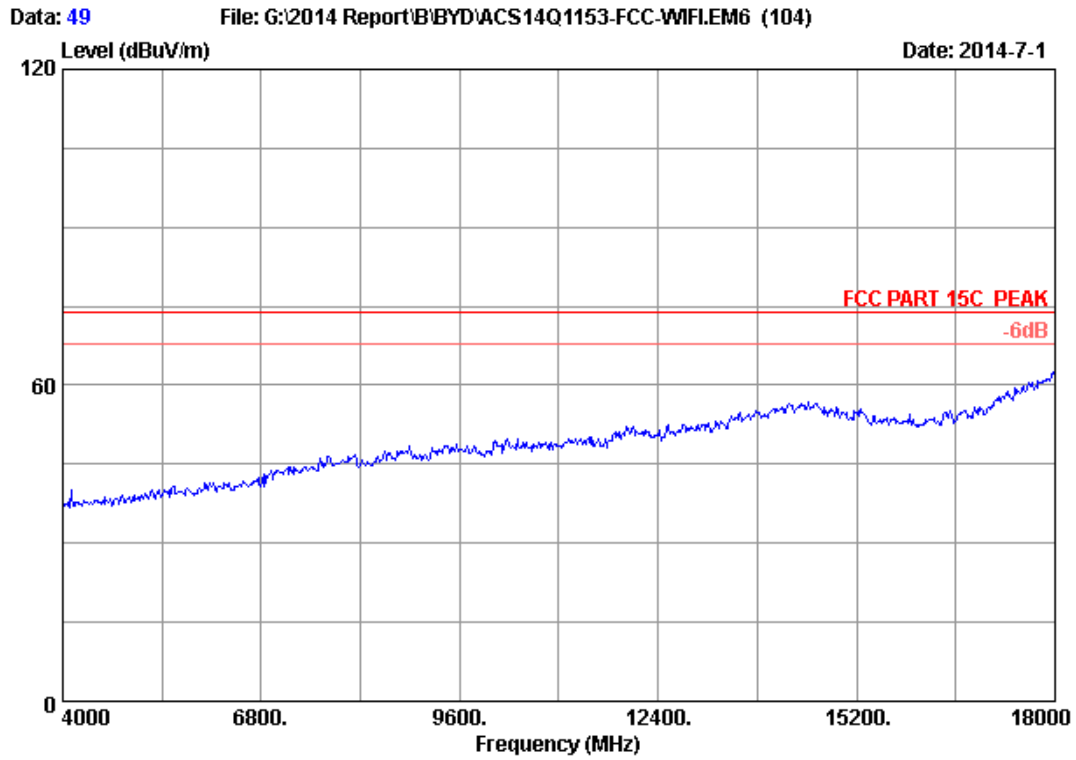

Site no. : 3m Chamber Data no. : 49
Dis. / Ant. : 3m 2013 3115 (4580) Ant. pol. : VERTICAL
Limit : FCC PART 15C PEAK
Env. / Ins. : 24°C/56% Engineer : Kevin_Hu
EUT : Tablet PC
Power Rating : DC 5V From Adapter Input AC 120V/60Hz
Test Mode : IEEE802.11g 2412MHz Tx Mode
M/N : WT7-C

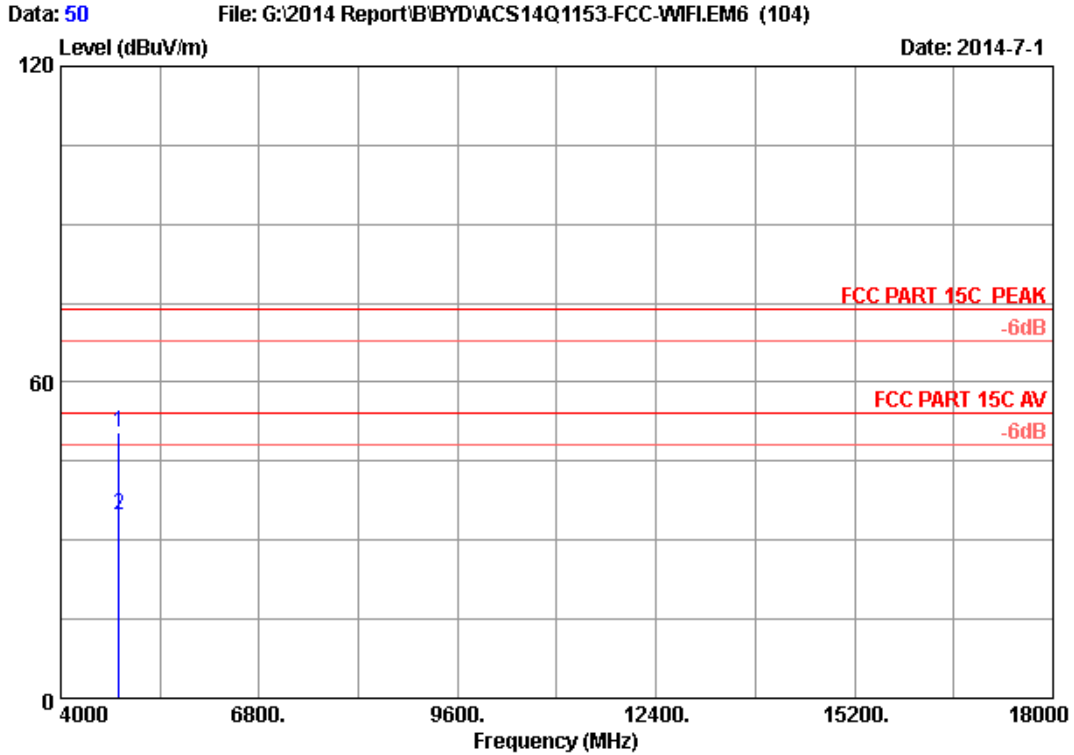

Site no. : 3m Chamber Data no. : 50
 Dis. / Ant. : 3m 2013 3115 (4580) Ant. pol. : VERTICAL
 Limit : FCC PART 15C PEAK
 Env. / Ins. : 24°C/56% Engineer : Kevin_Hu
 EUT : Tablet PC
 Power Rating : DC 5V From Adapter Input AC 120V/60Hz
 Test Mode : IEEE802.11g 2412MHz Tx Mode
 M/N : WT7-C

No.	Freq. (MHz)	Ant. Factor (dB/m)	Cable Loss (dB)	AMP factor (dB)	Reading (dBuV)	Emission Level (dBuV/m)	Limits (dBuV/m)	Margin (dB)	Remark
1	4824.000	32.88	8.58	35.70	44.77	50.53	74.00	23.47	Peak
2	4824.000	32.88	8.58	35.70	29.05	34.81	54.00	19.19	Average

Remarks: 1. Emission Level= Antenna Factor + Cable Loss + Reading - Amp Factor
 2. The emission levels that are 20dB below the official limit are not reported.

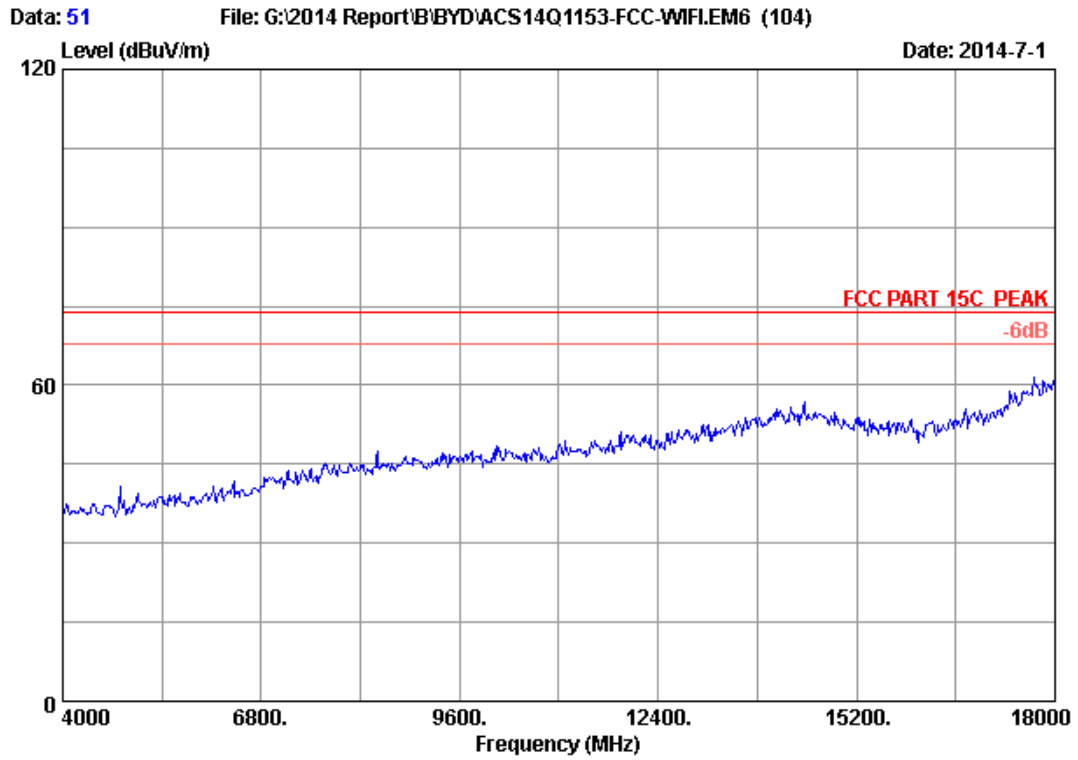

Site no. : 3m Chamber Data no. : 51
Dis. / Ant. : 3m 2013 3115 (4580) Ant. pol. : HORIZONTAL
Limit : FCC PART 15C PEAK
Env. / Ins. : 24°C/56% Engineer : Kevin_Hu
EUT : Tablet PC
Power Rating : DC 5V From Adapter Input AC 120V/60Hz
Test Mode : IEEE802.11g 2412MHz Tx Mode
M/N : WT7-C

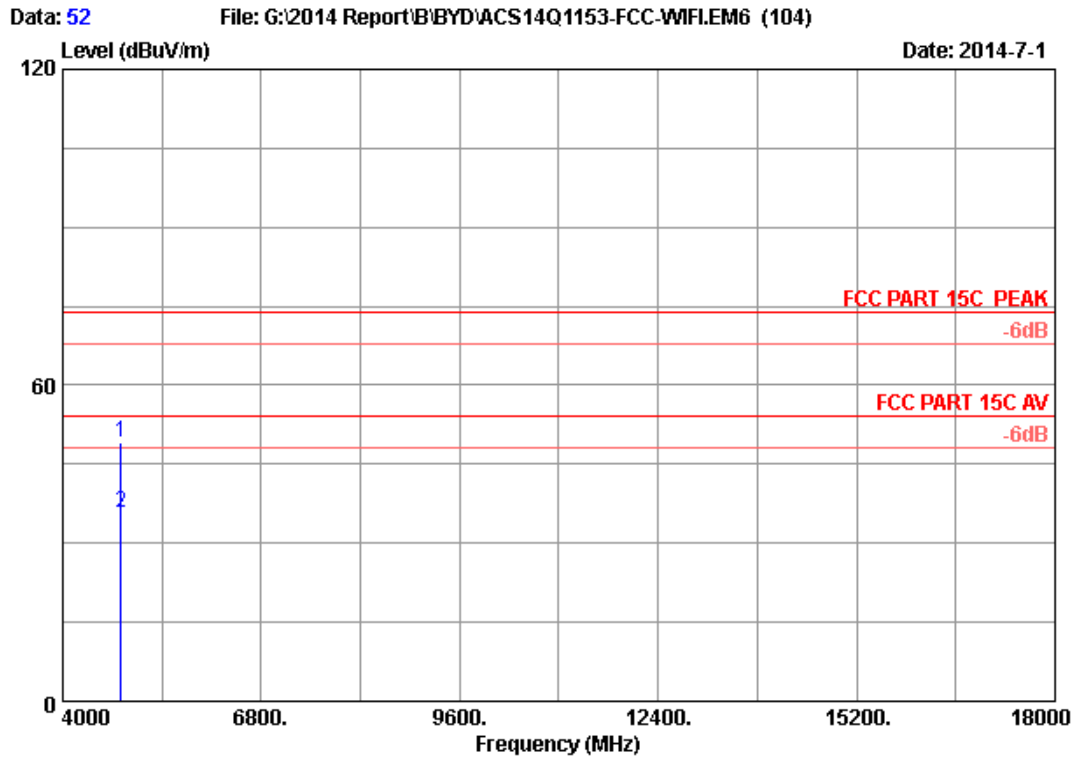

Site no. : 3m Chamber Data no. : 52
 Dis. / Ant. : 3m 2013 3115 (4580) Ant. pol. : HORIZONTAL
 Limit : FCC PART 15C PEAK
 Env. / Ins. : 24°C/56% Engineer : Kevin_Hu
 EUT : Tablet PC
 Power Rating : DC 5V From Adapter Input AC 120V/60Hz
 Test Mode : IEEE802.11g 2412MHz Tx Mode
 M/N : WT7-C

No.	Freq. (MHz)	Ant. Factor (dB/m)	Cable Loss (dB)	AMP factor (dB)	Reading (dBuV)	Emission Level (dBuV/m)	Limits (dBuV/m)	Margin (dB)	Remark
1	4824.000	32.88	8.58	35.70	43.25	49.01	74.00	24.99	Peak
2	4824.000	32.88	8.58	35.70	30.12	35.88	54.00	18.12	Average

Remarks: 1. Emission Level= Antenna Factor + Cable Loss + Reading - Amp Factor
 2. The emission levels that are 20dB below the official limit are not reported.

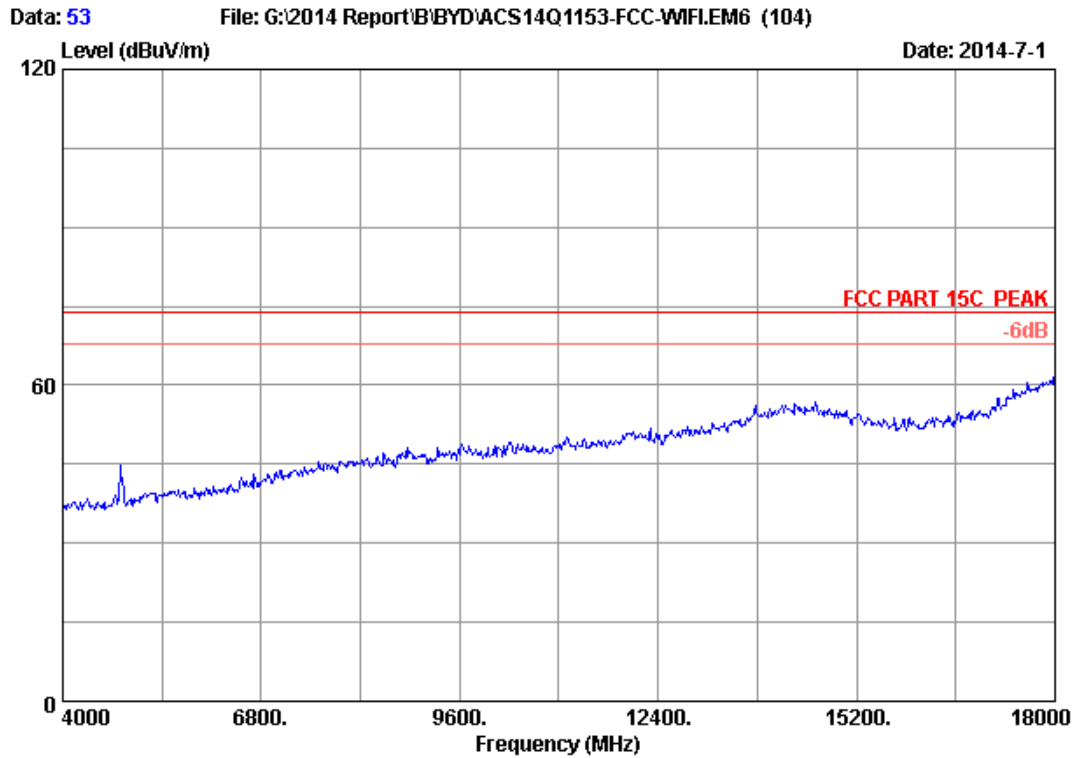

Site no. : 3m Chamber Data no. : 53
Dis. / Ant. : 3m 2013 3115 (4580) Ant. pol. : HORIZONTAL
Limit : FCC PART 15C PEAK
Env. / Ins. : 24°C/56% Engineer : Kevin_Hu
EUT : Tablet PC
Power Rating : DC 5V From Adapter Input AC 120V/60Hz
Test Mode : IEEE802.11nHT20 2412MHz Tx Mode
M/N : WT7-C

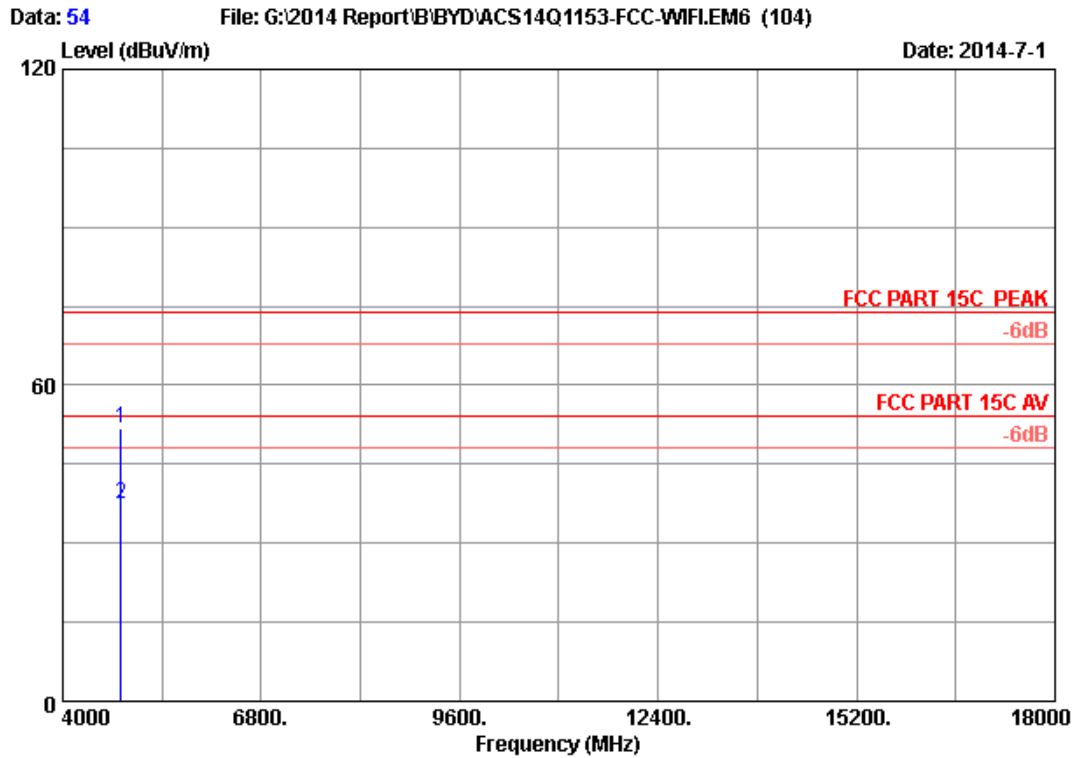

Site no. : 3m Chamber Data no. : 54
 Dis. / Ant. : 3m 2013 3115 (4580) Ant. pol. : HORIZONTAL
 Limit : FCC PART 15C PEAK
 Env. / Ins. : 24°C/56% Engineer : Kevin_Hu
 EUT : Tablet PC
 Power Rating : DC 5V From Adapter Input AC 120V/60Hz
 Test Mode : IEEE802.11nHT20 2412MHz Tx Mode
 M/N : WT7-C

No.	Freq. (MHz)	Ant. Factor (dB/m)	Cable Loss (dB)	AMP factor (dB)	Reading (dBuV)	Emission Level (dBuV/m)	Limits (dBuV/m)	Margin (dB)	Remark
1	4824.000	32.88	8.58	35.70	45.96	51.72	74.00	22.28	Peak
2	4824.000	32.88	8.58	35.70	31.52	37.28	54.00	16.72	Average

Remarks: 1. Emission Level= Antenna Factor + Cable Loss + Reading - Amp Factor
 2. The emission levels that are 20dB below the official limit are not reported.

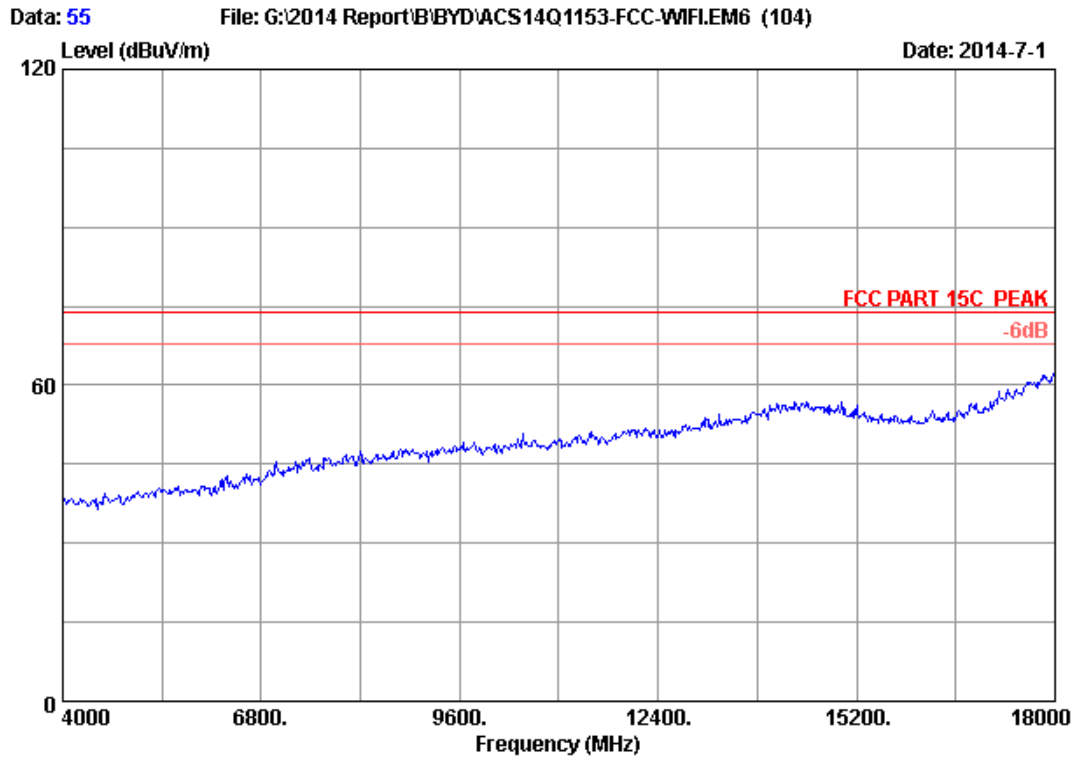

Site no. : 3m Chamber Data no. : 55
Dis. / Ant. : 3m 2013 3115 (4580) Ant. pol. : VERTICAL
Limit : FCC PART 15C PEAK
Env. / Ins. : 24°C/56% Engineer : Kevin_Hu
EUT : Tablet PC
Power Rating : DC 5V From Adapter Input AC 120V/60Hz
Test Mode : IEEE802.11nHT20 2412MHz Tx Mode
M/N : WT7-C

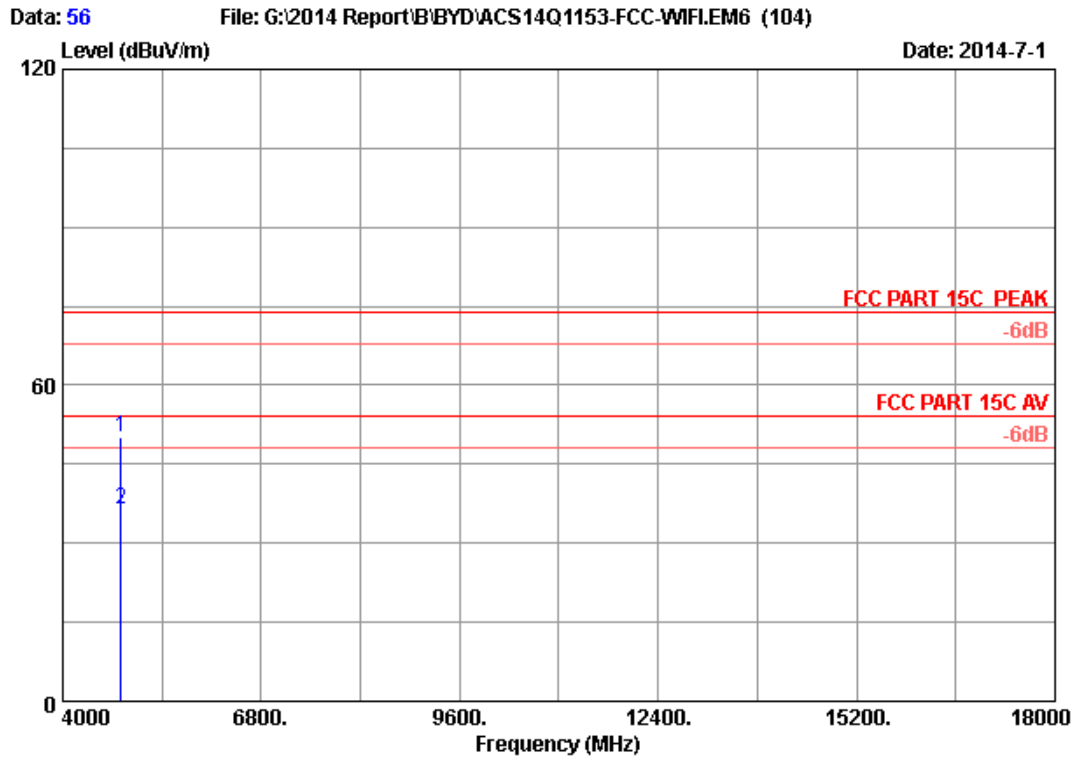

Site no. : 3m Chamber Data no. : 56
 Dis. / Ant. : 3m 2013 3115 (4580) Ant. pol. : VERTICAL
 Limit : FCC PART 15C PEAK
 Env. / Ins. : 24°C/56% Engineer : Kevin_Hu
 EUT : Tablet PC
 Power Rating : DC 5V From Adapter Input AC 120V/60Hz
 Test Mode : IEEE802.11nHT20 2412MHz Tx Mode
 M/N : WT7-C

No.	Freq. (MHz)	Ant. Factor (dB/m)	Cable Loss (dB)	AMP factor (dB)	Reading (dBUV)	Emission Level (dBUV/m)	Limits (dBUV/m)	Margin (dB)	Remark
1	4824.000	32.88	8.58	35.70	44.22	49.98	74.00	24.02	Peak
2	4824.000	32.88	8.58	35.70	30.62	36.38	54.00	17.62	Average

Remarks: 1. Emission Level= Antenna Factor + Cable Loss + Reading - Amp Factor
 2. The emission levels that are 20dB below the official limit are not reported.

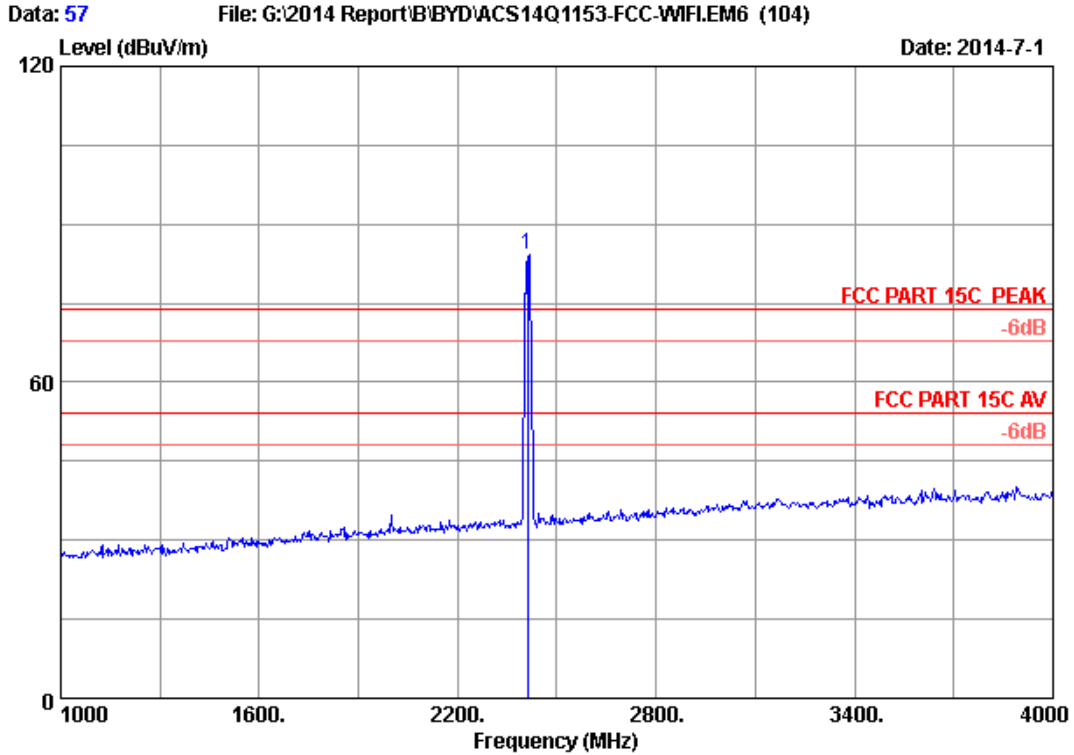

Site no. : 3m Chamber Data no. : 57
 Dis. / Ant. : 3m 2013 3115 (4580) Ant. pol. : VERTICAL
 Limit : FCC PART 15C PEAK
 Env. / Ins. : 24°C/56% Engineer : Kevin_Hu
 EUT : Tablet PC
 Power Rating : DC 5V From Adapter Input AC 120V/60Hz
 Test Mode : IEEE802.11nHT20 2412MHz Tx Mode
 M/N : WT7-C

No.	Freq. (MHz)	Ant. Factor (dB/m)	Cable Loss (dB)	AMP factor (dB)	Reading (dBUV)	Emission			Remark
						Level (dBUV/m)	Limits (dBUV/m)	Margin (dB)	
1	2412.000	28.21	5.81	35.70	86.06	84.38	74.00	-10.38	Peak

Remarks: 1. Emission Level= Antenna Factor + Cable Loss + Reading
 -Amp Factor
 2. The emission levels that are 20dB below the official
 limit are not reported.

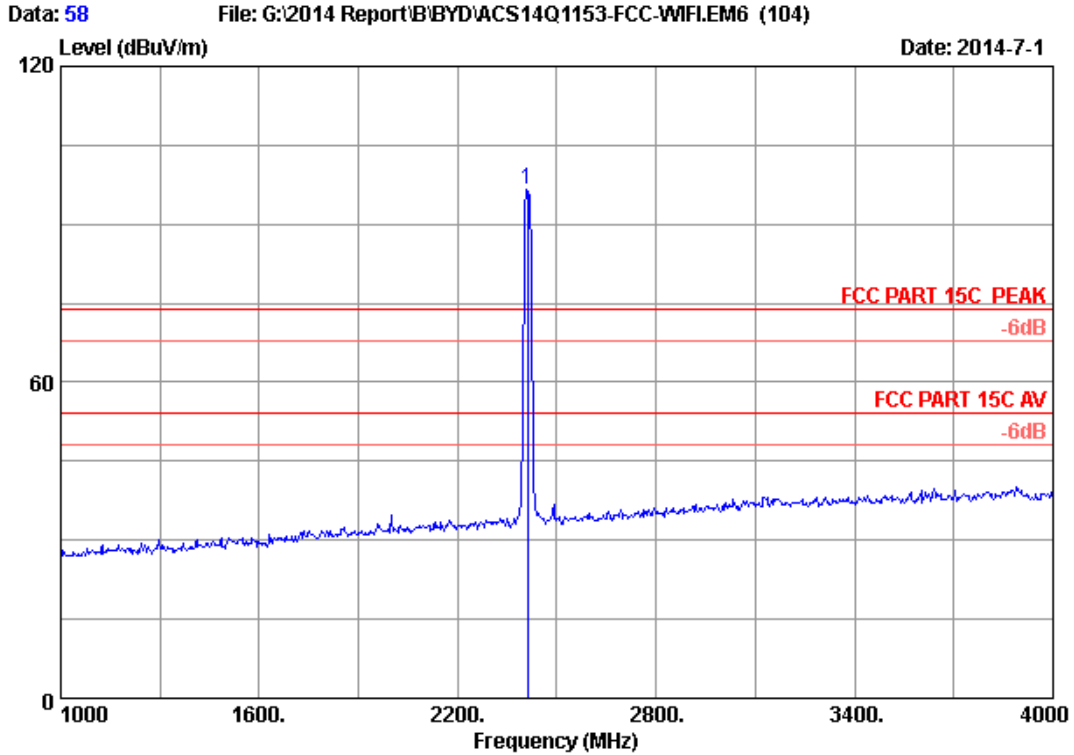

Site no. : 3m Chamber Data no. : 58
 Dis. / Ant. : 3m 2013 3115 (4580) Ant. pol. : HORIZONTAL
 Limit : FCC PART 15C PEAK
 Env. / Ins. : 24°C/56% Engineer : Kevin_Hu
 EUT : Tablet PC
 Power Rating : DC 5V From Adapter Input AC 120V/60Hz
 Test Mode : IEEE802.11nHT20 2412MHz Tx Mode
 M/N : WT7-C

No.	Freq. (MHz)	Ant. Factor (dB/m)	Cable Loss (dB)	AMP factor (dB)	Reading (dBuV)	Emission			Remark
						Level (dBuV/m)	Limits (dBuV/m)	Margin (dB)	
1	2412.000	28.21	5.81	35.70	98.14	96.46	74.00	-22.46	Peak

Remarks: 1. Emission Level= Antenna Factor + Cable Loss + Reading
 -Amp Factor
 2. The emission levels that are 20dB below the official
 limit are not reported.

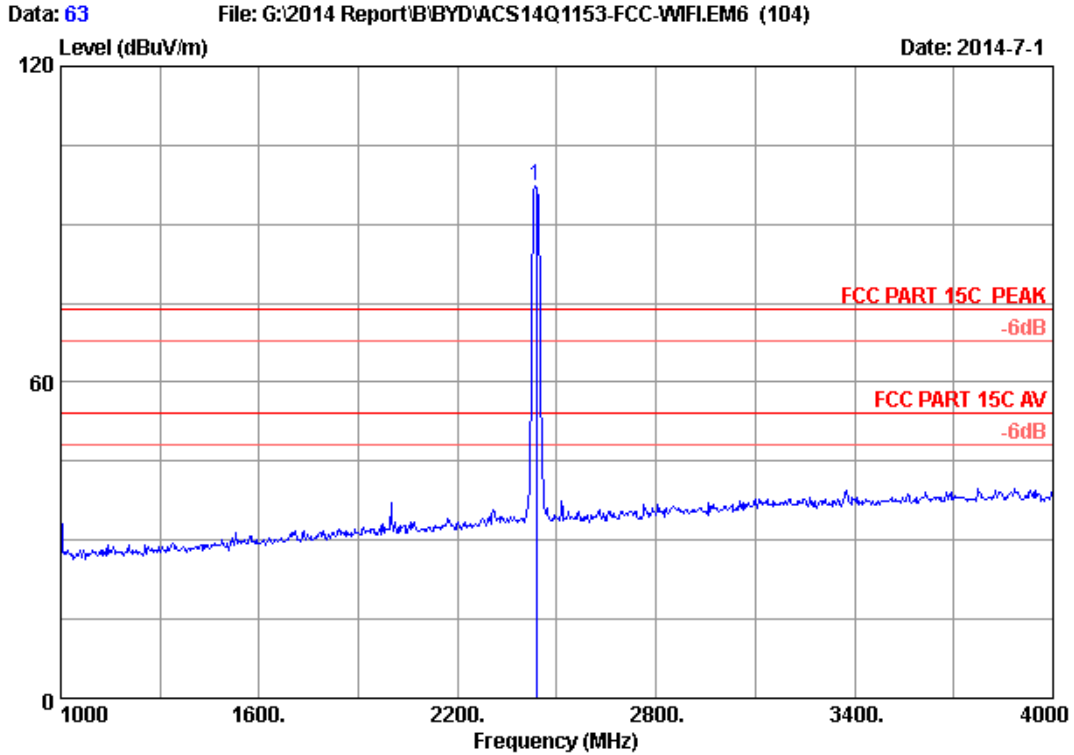

Site no. : 3m Chamber Data no. : 63
 Dis. / Ant. : 3m 2013 3115 (4580) Ant. pol. : HORIZONTAL
 Limit : FCC PART 15C PEAK
 Env. / Ins. : 24°C/56% Engineer : Kevin_Hu
 EUT : Tablet PC
 Power Rating : DC 5V From Adapter Input AC 120V/60Hz
 Test Mode : IEEE802.11nHT20 2437MHz Tx Mode
 M/N : WT7-C

No.	Freq. (MHz)	Ant. Factor (dB/m)	Cable Loss (dB)	AMP factor (dB)	Reading (dBuV)	Emission			Remark
						Level (dBuV/m)	Limits (dBuV/m)	Margin (dB)	
1	2437.000	28.26	5.85	35.70	98.87	97.28	74.00	-23.28	Peak

Remarks: 1. Emission Level= Antenna Factor + Cable Loss + Reading
 -Amp Factor
 2. The emission levels that are 20dB below the official
 limit are not reported.

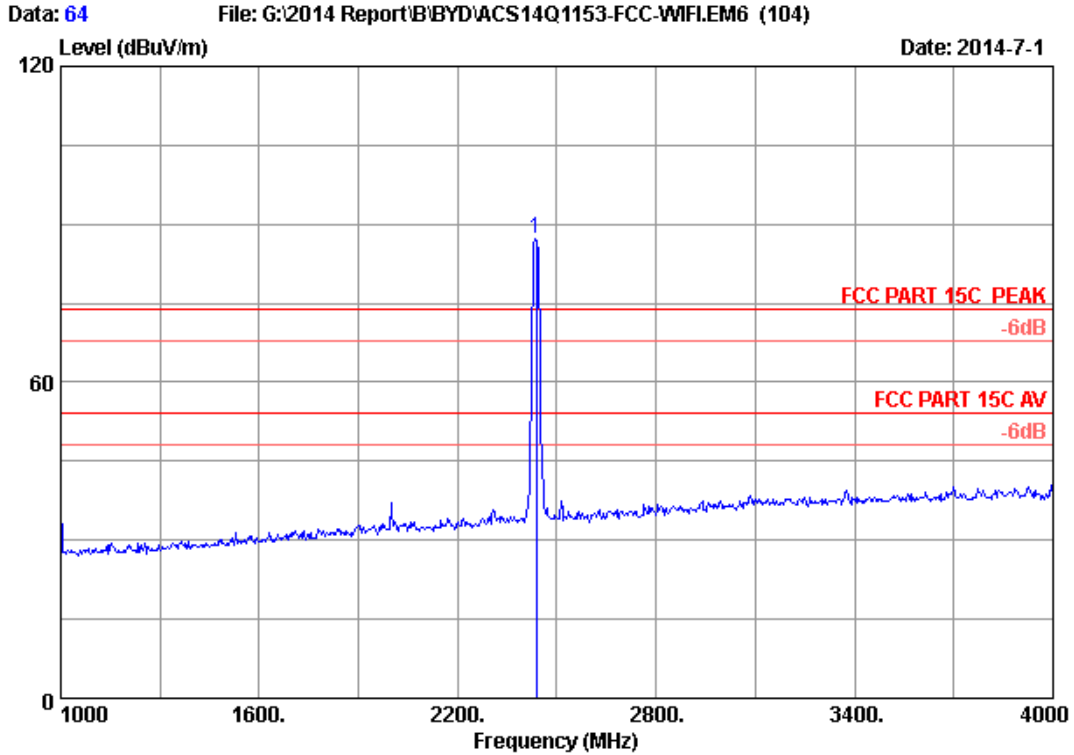

Site no. : 3m Chamber Data no. : 64
 Dis. / Ant. : 3m 2013 3115 (4580) Ant. pol. : VERTICAL
 Limit : FCC PART 15C PEAK
 Env. / Ins. : 24°C/56% Engineer : Kevin_Hu
 EUT : Tablet PC
 Power Rating : DC 5V From Adapter Input AC 120V/60Hz
 Test Mode : IEEE802.11nHT20 2437MHz Tx Mode
 M/N : WT7-C

No.	Freq. (MHz)	Ant. Factor (dB/m)	Cable Loss (dB)	AMP factor (dB)	Reading (dBuV)	Emission			Remark
						Level (dBuV/m)	Limits (dBuV/m)	Margin (dB)	
1	2437.000	28.26	5.85	35.70	88.87	87.28	74.00	-13.28	Peak

Remarks: 1. Emission Level= Antenna Factor + Cable Loss + Reading
 -Amp Factor
 2. The emission levels that are 20dB below the official
 limit are not reported.

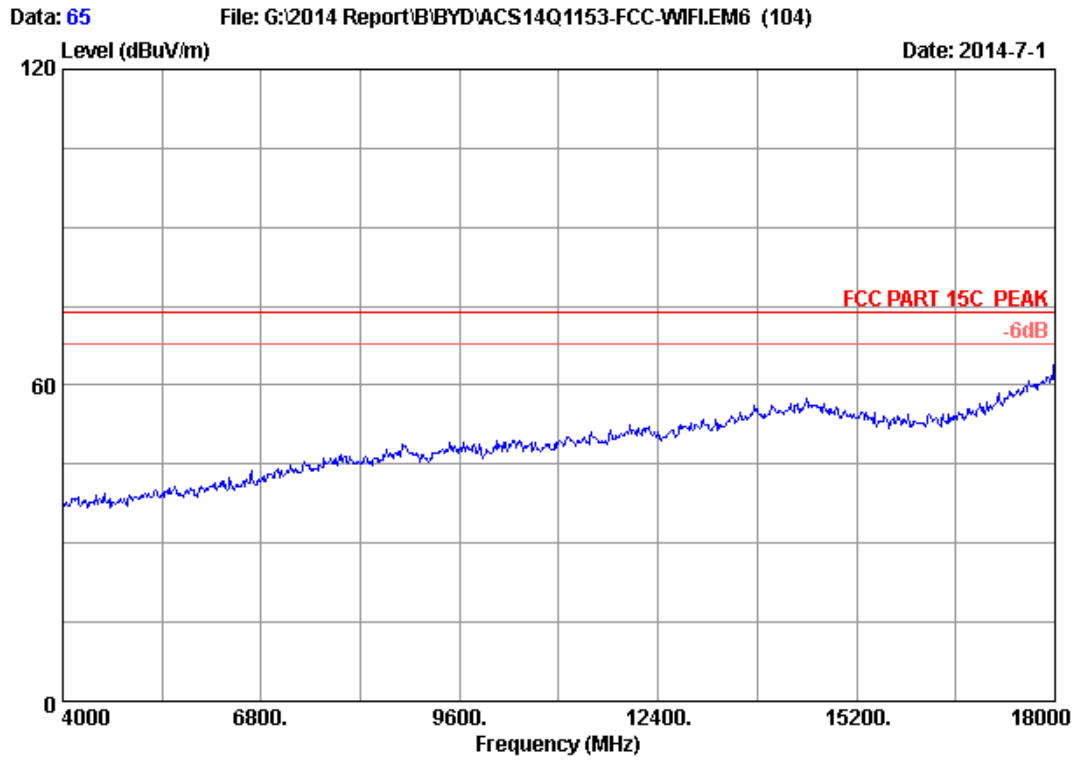

Site no. : 3m Chamber Data no. : 65
Dis. / Ant. : 3m 2013 3115 (4580) Ant. pol. : VERTICAL
Limit : FCC PART 15C PEAK
Env. / Ins. : 24°C/56% Engineer : Kevin_Hu
EUT : Tablet PC
Power Rating : DC 5V From Adapter Input AC 120V/60Hz
Test Mode : IEEE802.11nHT20 2437MHz Tx Mode
M/N : WT7-C

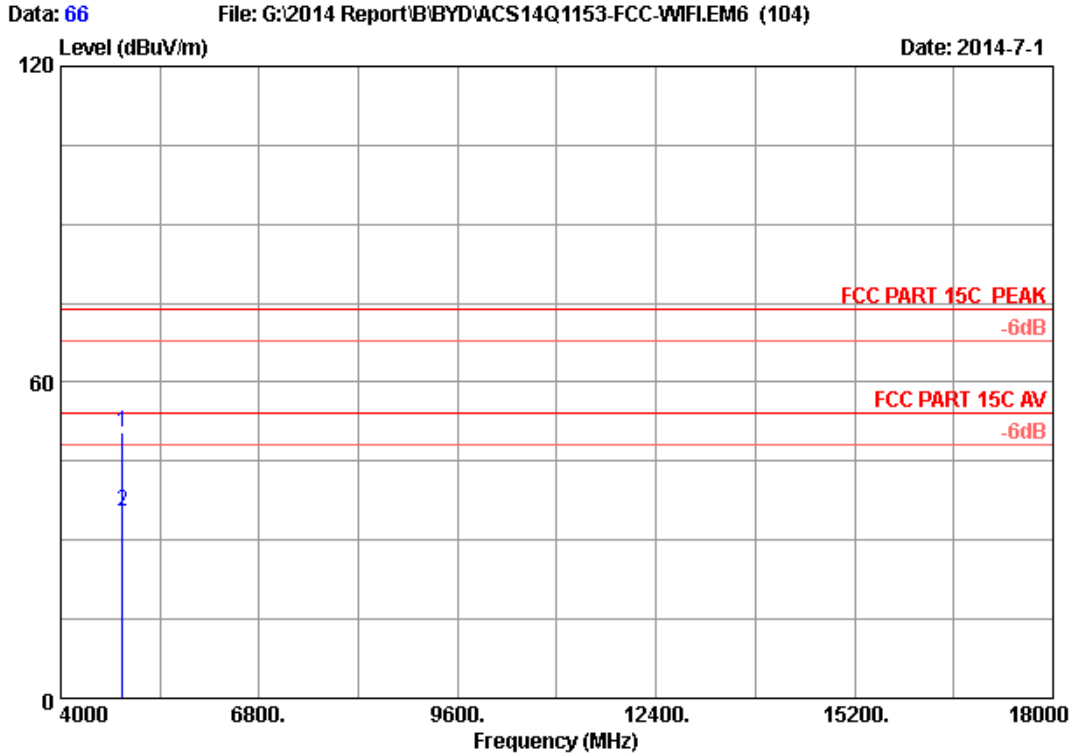

Site no. : 3m Chamber Data no. : 66
 Dis. / Ant. : 3m 2013 3115 (4580) Ant. pol. : VERTICAL
 Limit : FCC PART 15C PEAK
 Env. / Ins. : 24°C/56% Engineer : Kevin_Hu
 EUT : Tablet PC
 Power Rating : DC 5V From Adapter Input AC 120V/60Hz
 Test Mode : IEEE802.11nHT20 2437MHz Tx Mode
 M/N : WT7-C

No.	Freq. (MHz)	Ant. Factor (dB/m)	Cable Loss (dB)	AMP factor (dB)	Reading (dBUV)	Emission Level (dBUV/m)	Limits (dBUV/m)	Margin (dB)	Remark
1	4874.000	32.97	8.63	35.70	44.42	50.32	74.00	23.68	Peak
2	4874.000	32.97	8.63	35.70	29.63	35.53	54.00	18.47	Average

Remarks: 1. Emission Level= Antenna Factor + Cable Loss + Reading - Amp Factor
 2. The emission levels that are 20dB below the official limit are not reported.

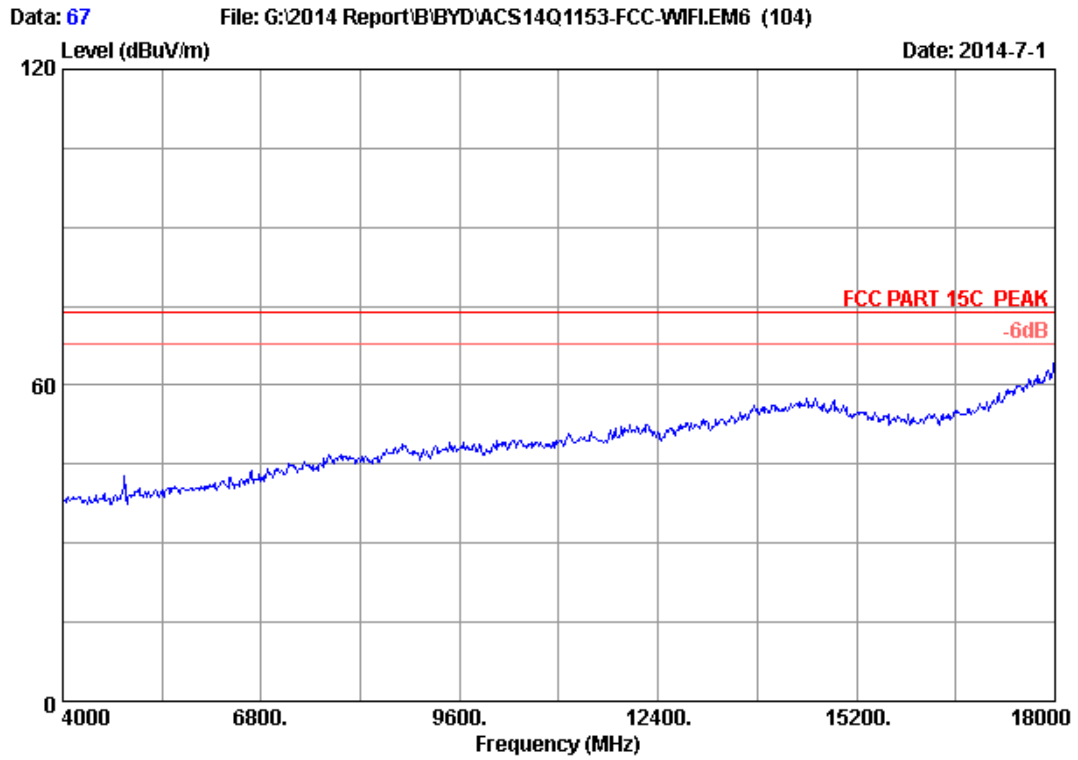

Site no. : 3m Chamber Data no. : 67
Dis. / Ant. : 3m 2013 3115 (4580) Ant. pol. : HORIZONTAL
Limit : FCC PART 15C PEAK
Env. / Ins. : 24°C/56% Engineer : Kevin_Hu
EUT : Tablet PC
Power Rating : DC 5V From Adapter Input AC 120V/60Hz
Test Mode : IEEE802.11nHT20 2437MHz Tx Mode
M/N : WT7-C

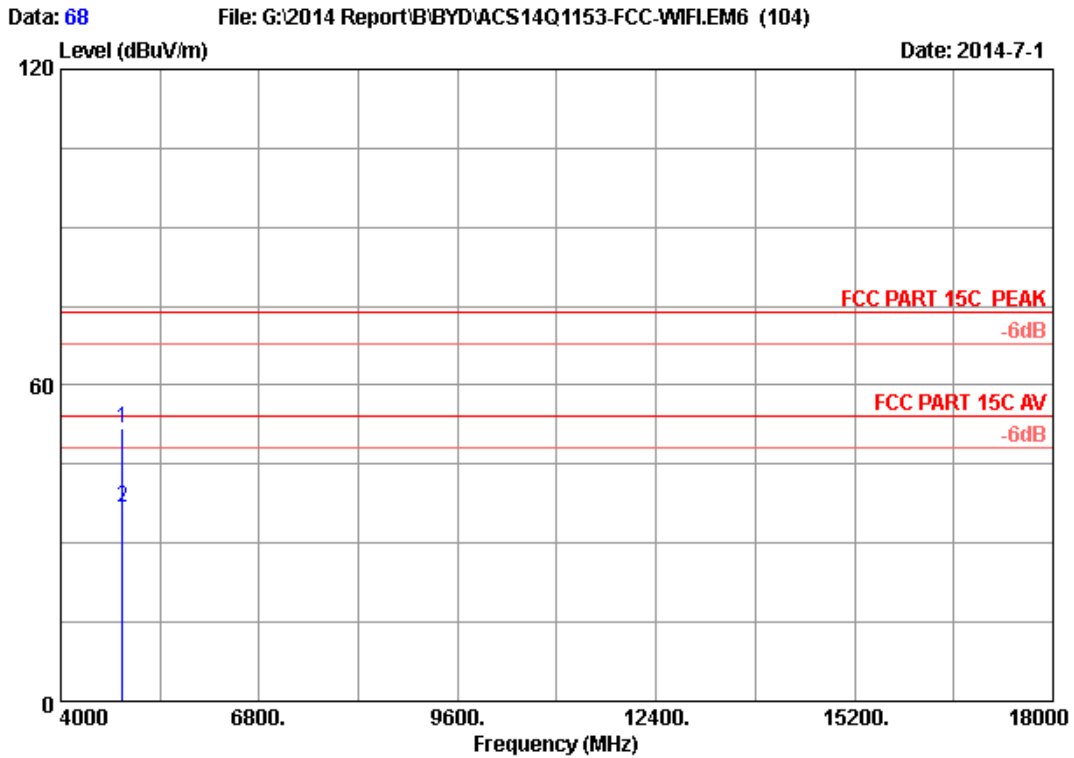

Site no. : 3m Chamber Data no. : 68
 Dis. / Ant. : 3m 2013 3115 (4580) Ant. pol. : HORIZONTAL
 Limit : FCC PART 15C PEAK
 Env. / Ins. : 24°C/56% Engineer : Kevin_Hu
 EUT : Tablet PC
 Power Rating : DC 5V From Adapter Input AC 120V/60Hz
 Test Mode : IEEE802.11nHT20 2437MHz Tx Mode
 M/N : WT7-C

No.	Freq. (MHz)	Ant. Factor (dB/m)	Cable Loss (dB)	AMP factor (dB)	Reading (dBuV)	Emission Level (dBuV/m)	Limits (dBuV/m)	Margin (dB)	Remark
1	4874.000	32.97	8.63	35.70	45.74	51.64	74.00	22.36	Peak
2	4874.000	32.97	8.63	35.70	30.80	36.70	54.00	17.30	Average

Remarks: 1. Emission Level= Antenna Factor + Cable Loss + Reading - Amp Factor
 2. The emission levels that are 20dB below the official limit are not reported.

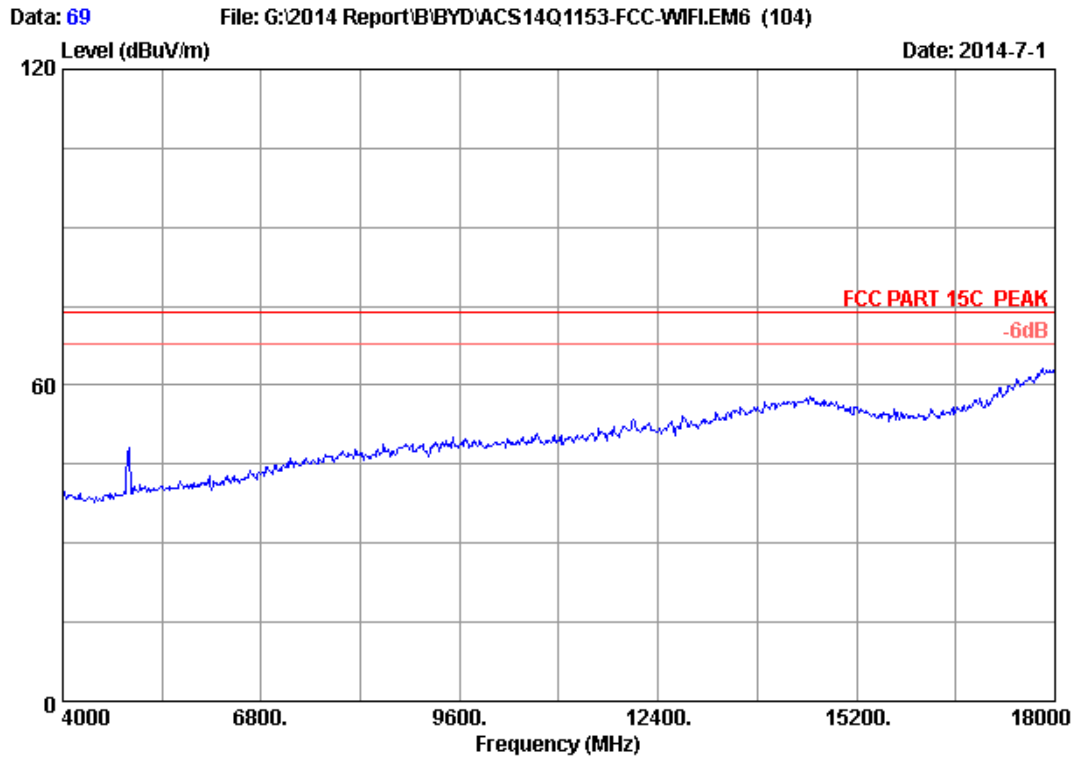

Site no. : 3m Chamber Data no. : 69
Dis. / Ant. : 3m 2013 3115 (4580) Ant. pol. : HORIZONTAL
Limit : FCC PART 15C PEAK
Env. / Ins. : 24°C/56% Engineer : Kevin_Hu
EUT : Tablet PC
Power Rating : DC 5V From Adapter Input AC 120V/60Hz
Test Mode : IEEE802.11nHT20 2462MHz Tx Mode
M/N : WT7-C

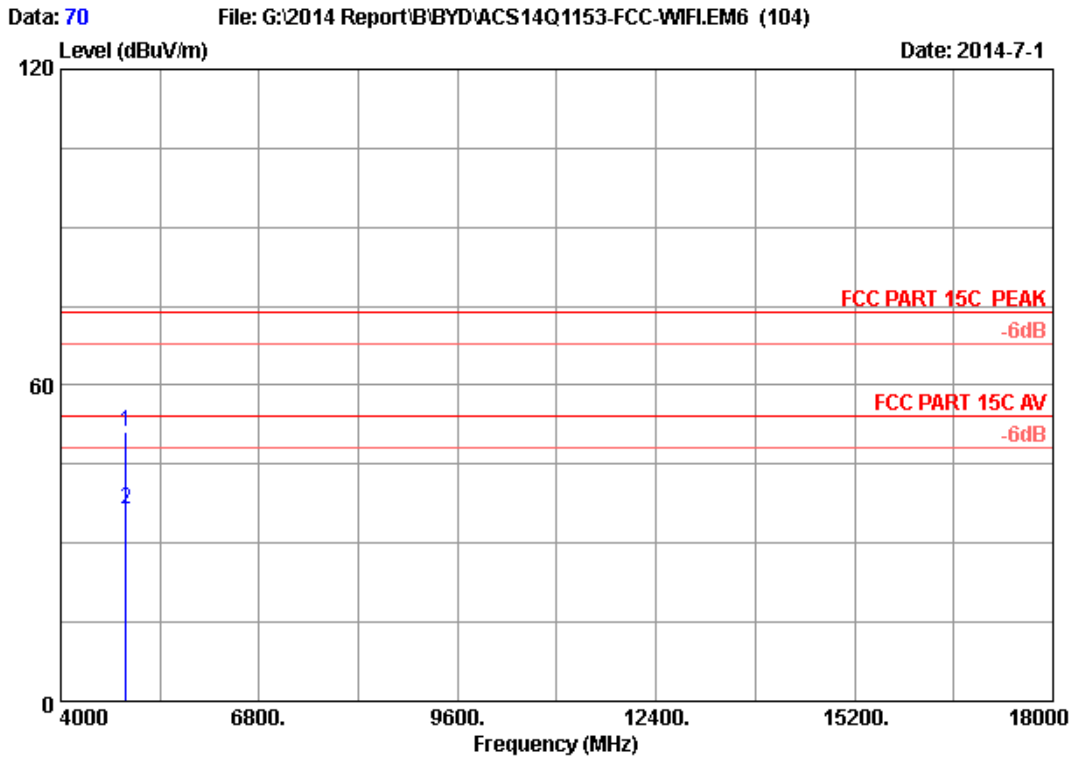

Site no. : 3m Chamber Data no. : 70
 Dis. / Ant. : 3m 2013 3115 (4580) Ant. pol. : HORIZONTAL
 Limit : FCC PART 15C PEAK
 Env. / Ins. : 24°C/56% Engineer : Kevin_Hu
 EUT : Tablet PC
 Power Rating : DC 5V From Adapter Input AC 120V/60Hz
 Test Mode : IEEE802.11nHT20 2462MHz Tx Mode
 M/N : WT7-C

No.	Freq. (MHz)	Ant. Factor (dB/m)	Cable Loss (dB)	AMP factor (dB)	Reading (dBuV)	Emission Level (dBuV/m)	Limits (dBuV/m)	Margin (dB)	Remark
1	4924.000	33.06	8.69	35.70	44.95	51.00	74.00	23.00	Peak
2	4924.000	33.06	8.69	35.70	30.52	36.57	54.00	17.43	Average

Remarks: 1. Emission Level= Antenna Factor + Cable Loss + Reading - Amp Factor
 2. The emission levels that are 20dB below the official limit are not reported.

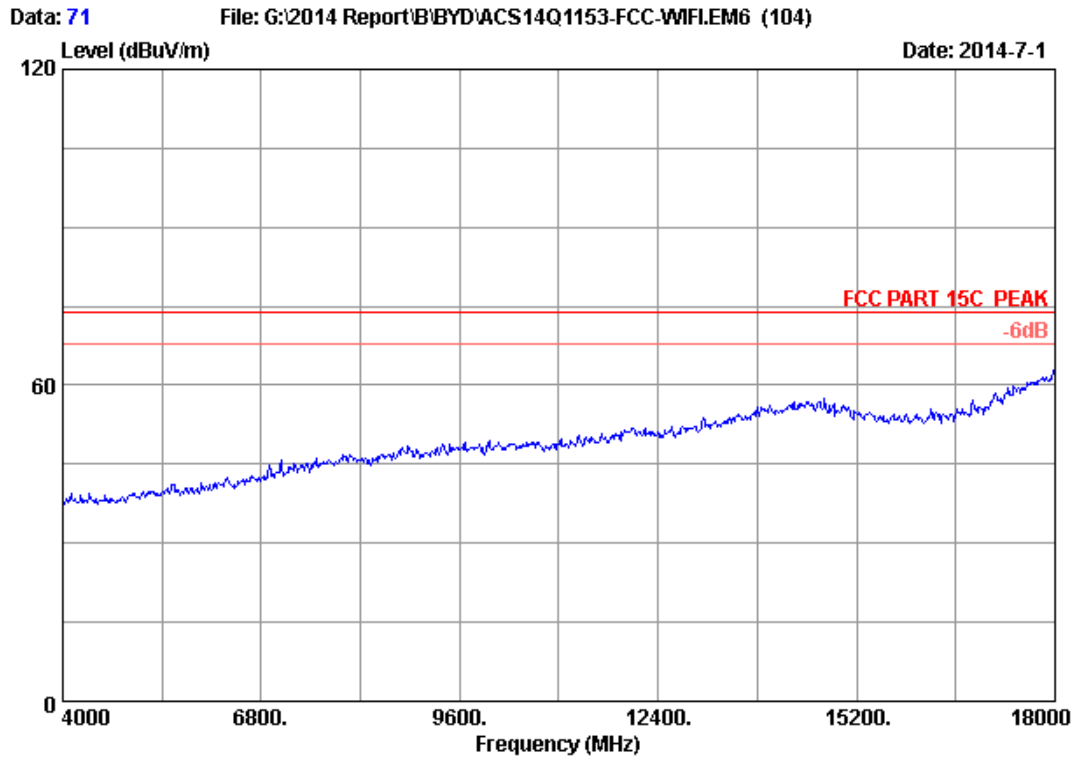

Site no. : 3m Chamber Data no. : 71
Dis. / Ant. : 3m 2013 3115 (4580) Ant. pol. : VERTICAL
Limit : FCC PART 15C PEAK
Env. / Ins. : 24°C/56% Engineer : Kevin_Hu
EUT : Tablet PC
Power Rating : DC 5V From Adapter Input AC 120V/60Hz
Test Mode : IEEE802.11nHT20 2462MHz Tx Mode
M/N : WT7-C

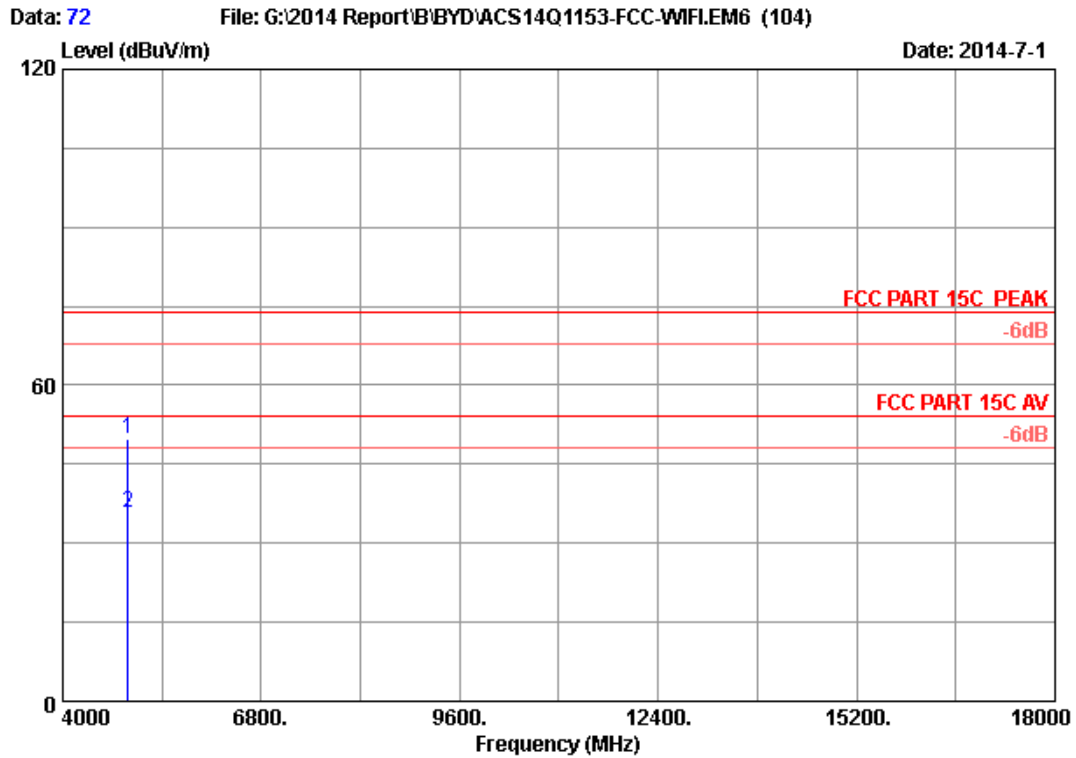

Site no. : 3m Chamber Data no. : 72
 Dis. / Ant. : 3m 2013 3115 (4580) Ant. pol. : VERTICAL
 Limit : FCC PART 15C PEAK
 Env. / Ins. : 24°C/56% Engineer : Kevin_Hu
 EUT : Tablet PC
 Power Rating : DC 5V From Adapter Input AC 120V/60Hz
 Test Mode : IEEE802.11nHT20 2462MHz Tx Mode
 M/N : WT7-C

No.	Freq. (MHz)	Ant. Factor (dB/m)	Cable Loss (dB)	AMP factor (dB)	Reading (dBuV)	Emission Level (dBuV/m)	Limits (dBuV/m)	Margin (dB)	Remark
1	4924.000	33.06	8.69	35.70	43.63	49.68	74.00	24.32	Peak
2	4924.000	33.06	8.69	35.70	29.83	35.88	54.00	18.12	Average

Remarks: 1. Emission Level= Antenna Factor + Cable Loss + Reading - Amp Factor
 2. The emission levels that are 20dB below the official limit are not reported.

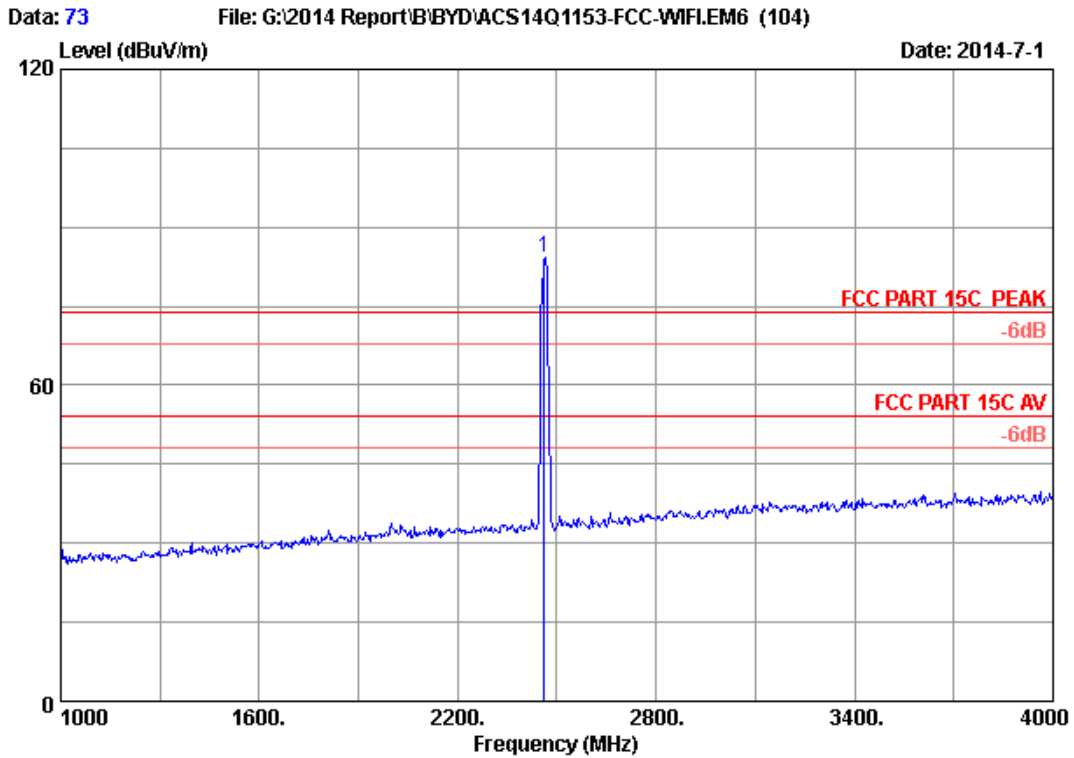

Site no. : 3m Chamber Data no. : 73
 Dis. / Ant. : 3m 2013 3115 (4580) Ant. pol. : VERTICAL
 Limit : FCC PART 15C PEAK
 Env. / Ins. : 24°C/56% Engineer : Kevin_Hu
 EUT : Tablet PC
 Power Rating : DC 5V From Adapter Input AC 120V/60Hz
 Test Mode : IEEE802.11nHT20 2462MHz Tx Mode
 M/N : WT7-C

No.	Freq. (MHz)	Ant. Factor (dB/m)	Cable Loss (dB)	AMP factor (dB)	Reading (dBUV)	Emission			Remark
						Level (dBUV/m)	Limits (dBUV/m)	Margin (dB)	
1	2462.000	28.32	5.89	35.70	85.61	84.12	74.00	-10.12	Peak

Remarks: 1. Emission Level= Antenna Factor + Cable Loss + Reading - Amp Factor
 2. The emission levels that are 20dB below the official limit are not reported.

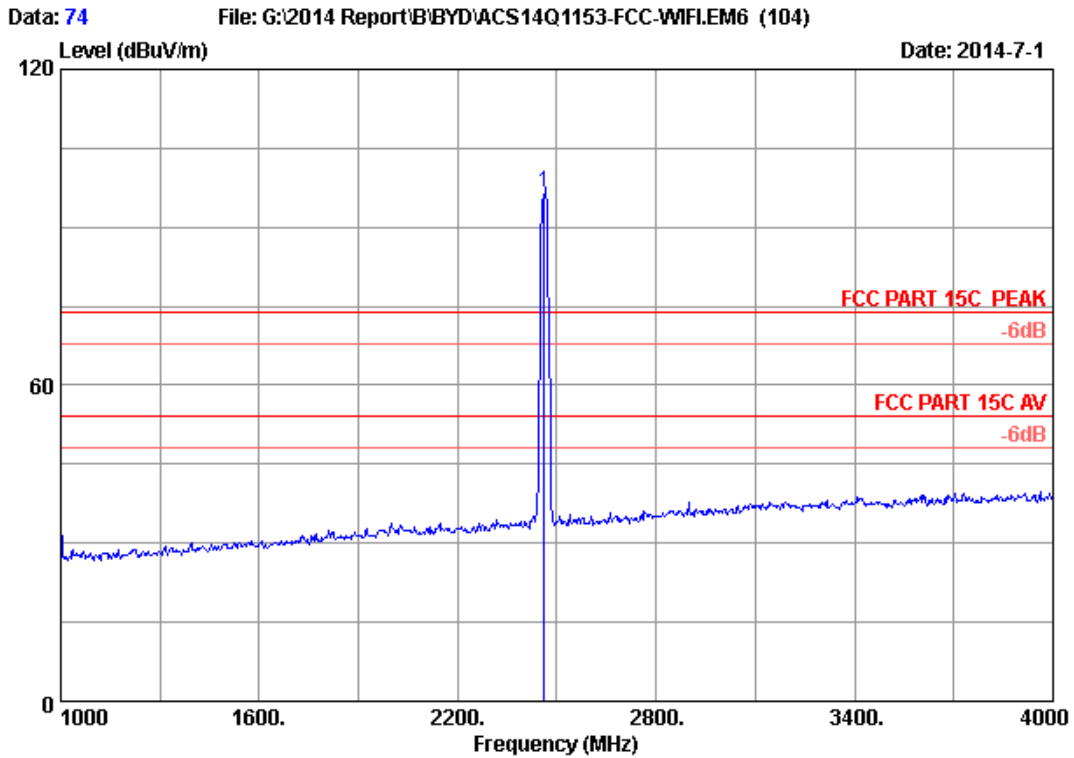

Site no. : 3m Chamber Data no. : 74
 Dis. / Ant. : 3m 2013 3115 (4580) Ant. pol. : HORIZONTAL
 Limit : FCC PART 15C PEAK
 Env. / Ins. : 24°C/56% Engineer : Kevin_Hu
 EUT : Tablet PC
 Power Rating : DC 5V From Adapter Input AC 120V/60Hz
 Test Mode : IEEE802.11nHT20 2462MHz Tx Mode
 M/N : WT7-C

No.	Freq. (MHz)	Ant. Factor (dB/m)	Cable Loss (dB)	AMP factor (dB)	Reading (dBuV)	Emission			Remark
						Level (dBuV/m)	Limits (dBuV/m)	Margin (dB)	
1	2462.000	28.32	5.89	35.70	97.95	96.46	74.00	-22.46	Peak

Remarks: 1. Emission Level= Antenna Factor + Cable Loss + Reading
 -Amp Factor
 2. The emission levels that are 20dB below the official
 limit are not reported.

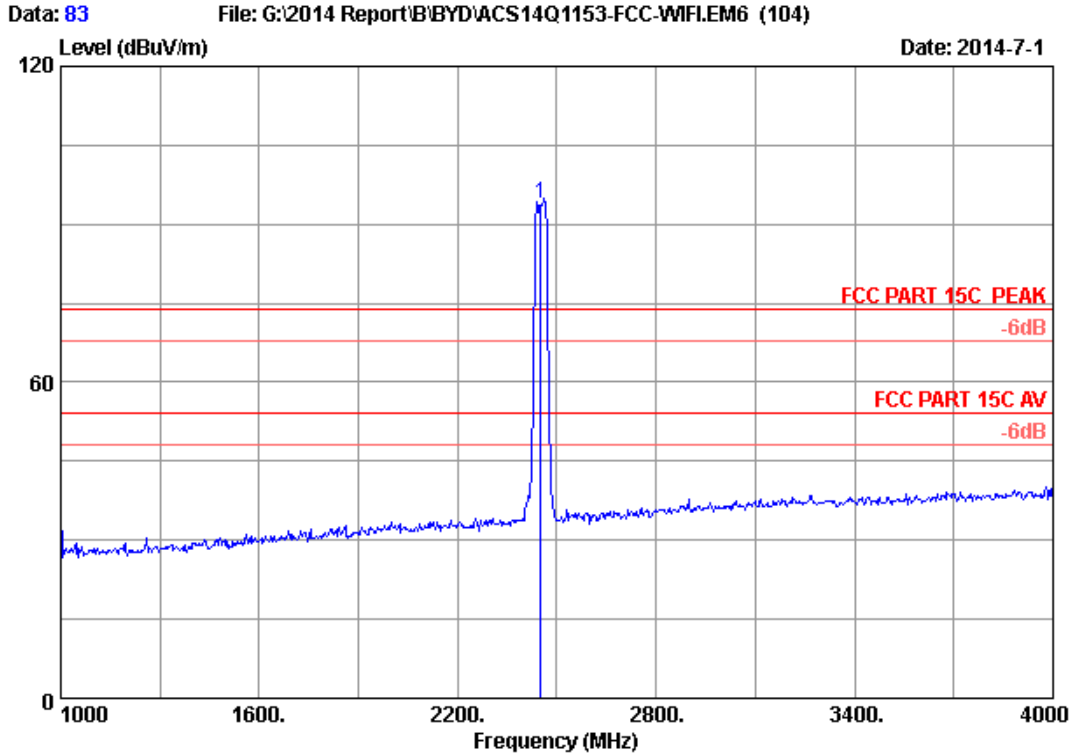

Site no. : 3m Chamber Data no. : 83
 Dis. / Ant. : 3m 2013 3115 (4580) Ant. pol. : HORIZONTAL
 Limit : FCC PART 15C PEAK
 Env. / Ins. : 24°C/56% Engineer : Kevin_Hu
 EUT : Tablet PC
 Power Rating : DC 5V From Adapter Input AC 120V/60Hz
 Test Mode : IEEE802.11nHT40 2452MHz Tx Mode
 M/N : WT7-C

No.	Freq. (MHz)	Ant. Factor (dB/m)	Cable Loss (dB)	AMP factor (dB)	Reading (dBUV)	Emission			Remark
						Level (dBUV/m)	Limits (dBUV/m)	Margin (dB)	
1	2452.000	28.29	5.87	35.70	95.44	93.90	74.00	-19.90	Peak

Remarks: 1. Emission Level= Antenna Factor + Cable Loss + Reading
 -Amp Factor
 2. The emission levels that are 20dB below the official
 limit are not reported.

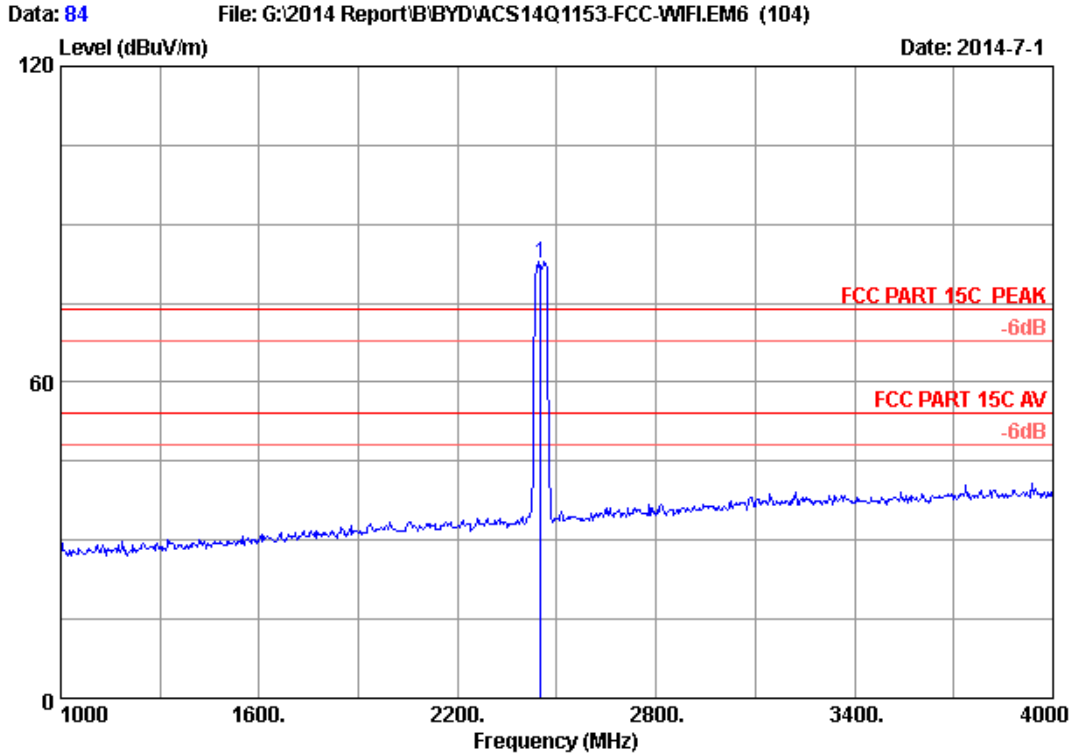

Site no. : 3m Chamber Data no. : 84
 Dis. / Ant. : 3m 2013 3115 (4580) Ant. pol. : VERTICAL
 Limit : FCC PART 15C PEAK
 Env. / Ins. : 24°C/56% Engineer : Kevin_Hu
 EUT : Tablet PC
 Power Rating : DC 5V From Adapter Input AC 120V/60Hz
 Test Mode : IEEE802.11nHT40 2452MHz Tx Mode
 M/N : WT7-C

No.	Freq. (MHz)	Ant. Factor (dB/m)	Cable Loss (dB)	AMP factor (dB)	Reading (dBuV)	Emission			Remark
						Level (dBuV/m)	Limits (dBuV/m)	Margin (dB)	
1	2452.000	28.29	5.87	35.70	83.95	82.41	74.00	-8.41	Peak

Remarks: 1. Emission Level= Antenna Factor + Cable Loss + Reading
 -Amp Factor
 2. The emission levels that are 20dB below the official
 limit are not reported.

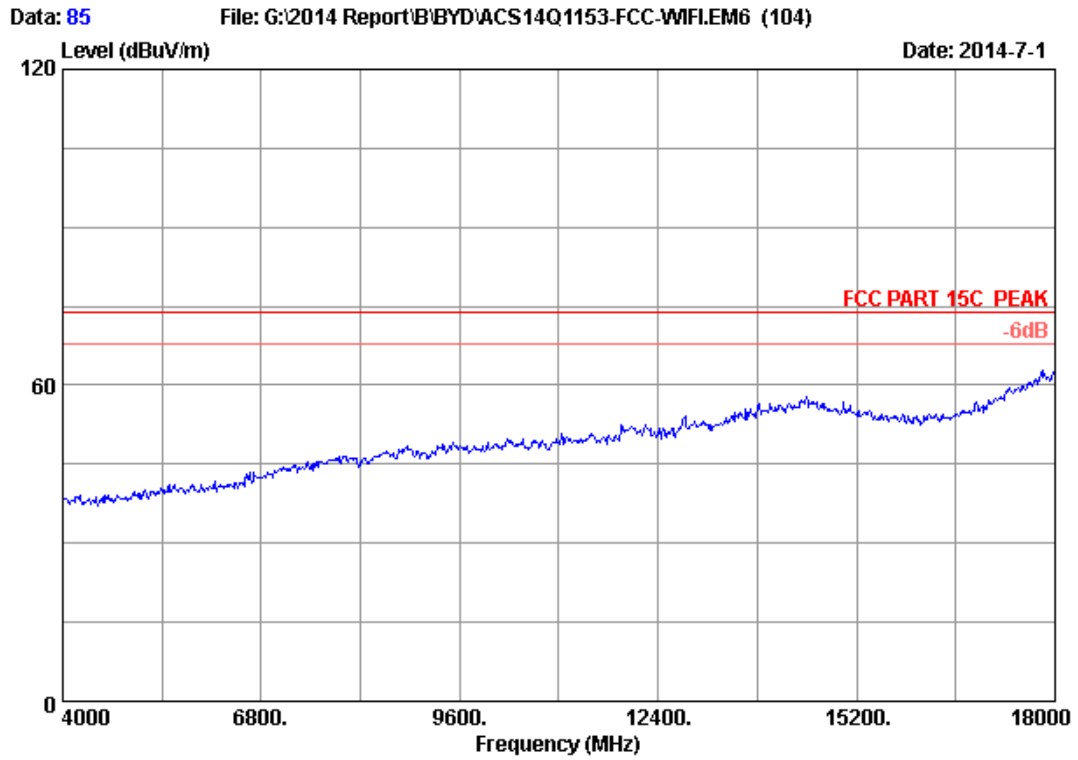

Site no. : 3m Chamber Data no. : 85
Dis. / Ant. : 3m 2013 3115 (4580) Ant. pol. : VERTICAL
Limit : FCC PART 15C PEAK
Env. / Ins. : 24°C/56% Engineer : Kevin_Hu
EUT : Tablet PC
Power Rating : DC 5V From Adapter Input AC 120V/60Hz
Test Mode : IEEE802.11nHT40 2452MHz Tx Mode
M/N : WT7-C

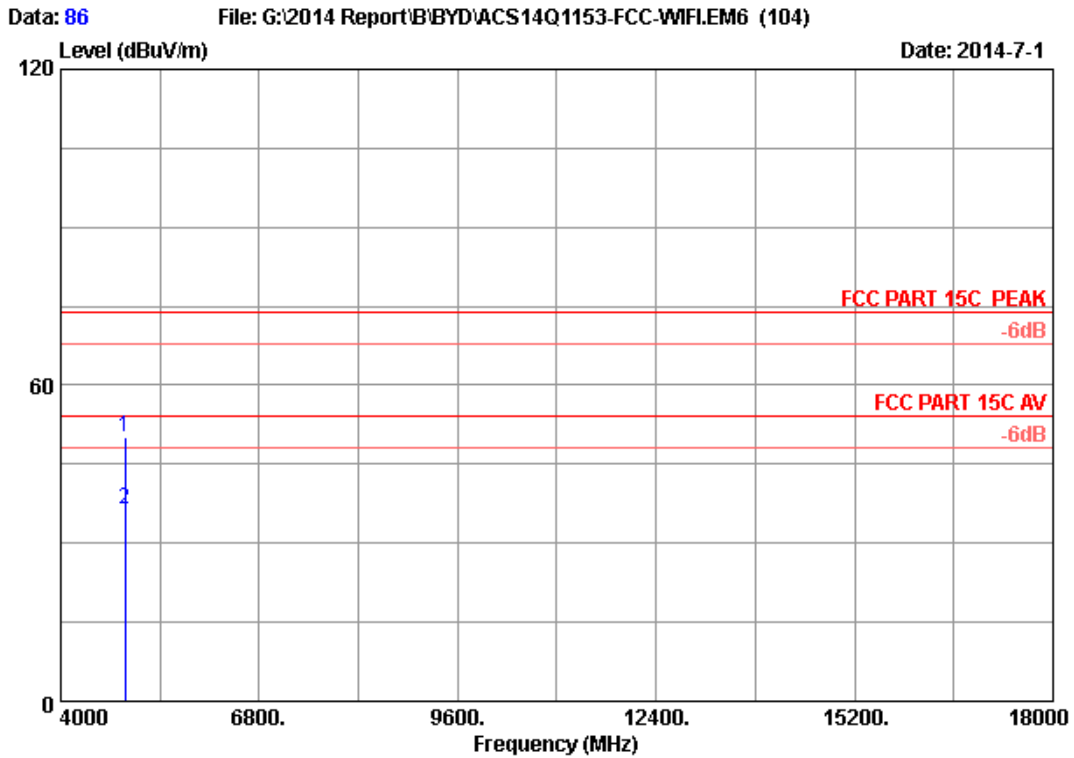

Site no. : 3m Chamber Data no. : 86
 Dis. / Ant. : 3m 2013 3115 (4580) Ant. pol. : VERTICAL
 Limit : FCC PART 15C PEAK
 Env. / Ins. : 24*C/56% Engineer : Kevin_Hu
 EUT : Tablet PC
 Power Rating : DC 5V From Adapter Input AC 120V/60Hz
 Test Mode : IEEE802.11nHT40 2452MHz Tx Mode
 M/N : WT7-C

No.	Freq. (MHz)	Ant. Factor (dB/m)	Cable Loss (dB)	AMP factor (dB)	Reading (dBuV)	Emission Level (dBuV/m)	Limits (dBuV/m)	Margin (dB)	Remark
1	4904.000	33.03	8.66	35.70	44.28	50.27	74.00	23.73	Peak
2	4904.000	33.03	8.66	35.70	30.51	36.50	54.00	17.50	Average

Remarks: 1. Emission Level= Antenna Factor + Cable Loss + Reading - Amp Factor
 2. The emission levels that are 20dB below the official limit are not reported.

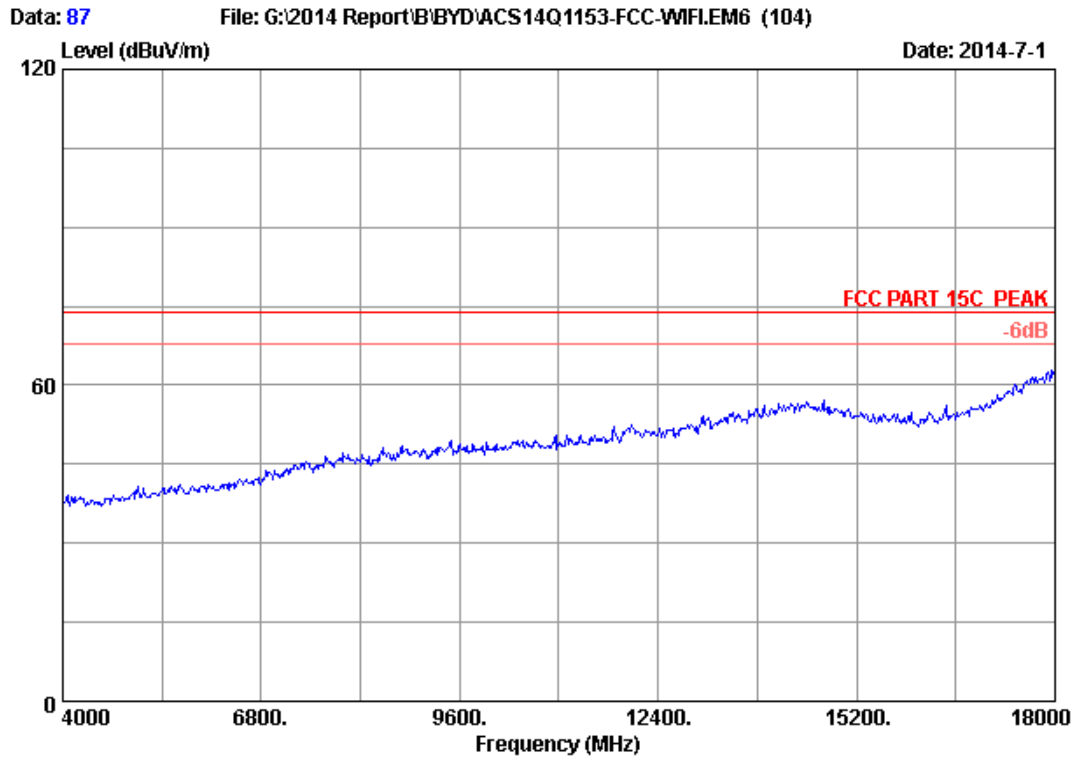

Site no. : 3m Chamber Data no. : 87
Dis. / Ant. : 3m 2013 3115 (4580) Ant. pol. : HORIZONTAL
Limit : FCC PART 15C PEAK
Env. / Ins. : 24°C/56% Engineer : Kevin_Hu
EUT : Tablet PC
Power Rating : DC 5V From Adapter Input AC 120V/60Hz
Test Mode : IEEE802.11nHT40 2452MHz Tx Mode
M/N : WT7-C

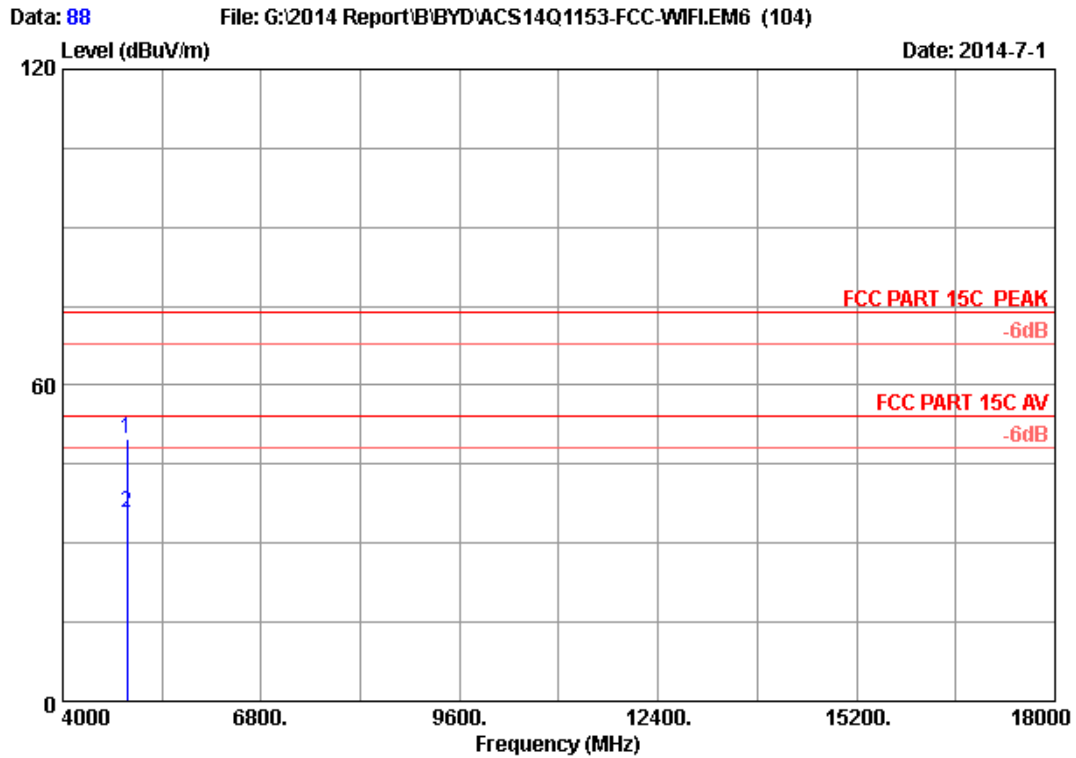

Site no. : 3m Chamber Data no. : 88
 Dis. / Ant. : 3m 2013 3115 (4580) Ant. pol. : HORIZONTAL
 Limit : FCC PART 15C PEAK
 Env. / Ins. : 24°C/56% Engineer : Kevin_Hu
 EUT : Tablet PC
 Power Rating : DC 5V From Adapter Input AC 120V/60Hz
 Test Mode : IEEE802.11nHT40 2452MHz Tx Mode
 M/N : WT7-C

No.	Freq. (MHz)	Ant. Factor (dB/m)	Cable Loss (dB)	AMP factor (dB)	Reading (dBuV)	Emission Level (dBuV/m)	Limits (dBuV/m)	Margin (dB)	Remark
1	4904.000	33.03	8.66	35.70	43.95	49.94	74.00	24.06	Peak
2	4904.000	33.03	8.66	35.70	29.62	35.61	54.00	18.39	Average

Remarks: 1. Emission Level= Antenna Factor + Cable Loss + Reading - Amp Factor
 2. The emission levels that are 20dB below the official limit are not reported.

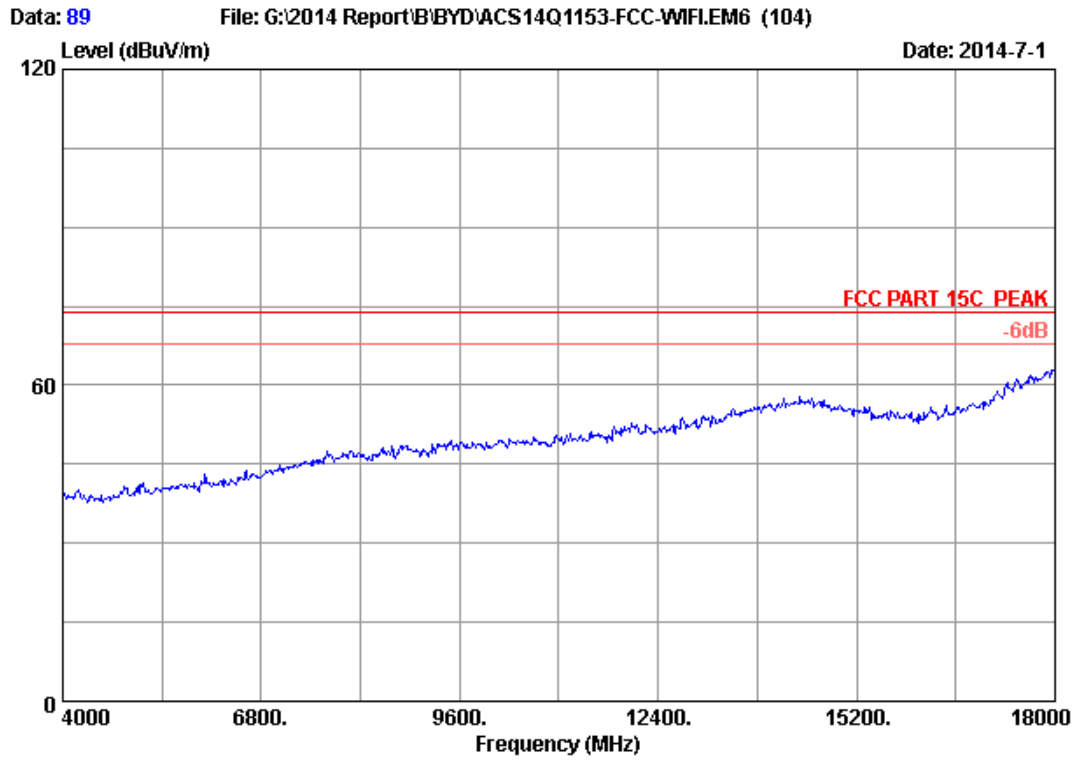

Site no. : 3m Chamber Data no. : 89
Dis. / Ant. : 3m 2013 3115 (4580) Ant. pol. : HORIZONTAL
Limit : FCC PART 15C PEAK
Env. / Ins. : 24°C/56% Engineer : Kevin_Hu
EUT : Tablet PC
Power Rating : DC 5V From Adapter Input AC 120V/60Hz
Test Mode : IEEE802.11nHT40 2437MHz Tx Mode
M/N : WT7-C

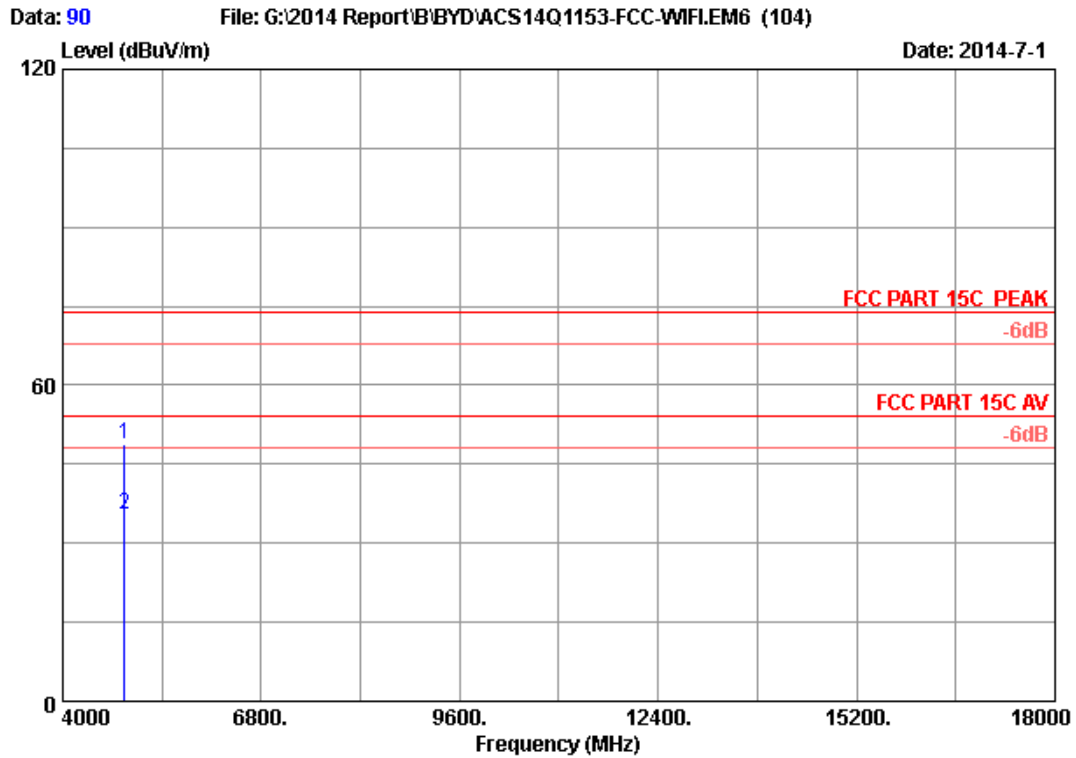

Site no. : 3m Chamber Data no. : 90
 Dis. / Ant. : 3m 2013 3115 (4580) Ant. pol. : HORIZONTAL
 Limit : FCC PART 15C PEAK
 Env. / Ins. : 24°C/56% Engineer : Kevin_Hu
 EUT : Tablet PC
 Power Rating : DC 5V From Adapter Input AC 120V/60Hz
 Test Mode : IEEE802.11nHT40 2437MHz Tx Mode
 M/N : WT7-C

No.	Freq. (MHz)	Ant. Factor (dB/m)	Cable Loss (dB)	AMP factor (dB)	Reading (dBuV)	Emission Level (dBuV/m)	Limits (dBuV/m)	Margin (dB)	Remark
1	4874.000	32.97	8.63	35.70	43.03	48.93	74.00	25.07	Peak
2	4874.000	32.97	8.63	35.70	29.66	35.56	54.00	18.44	Average

Remarks: 1. Emission Level= Antenna Factor + Cable Loss + Reading - Amp Factor
 2. The emission levels that are 20dB below the official limit are not reported.

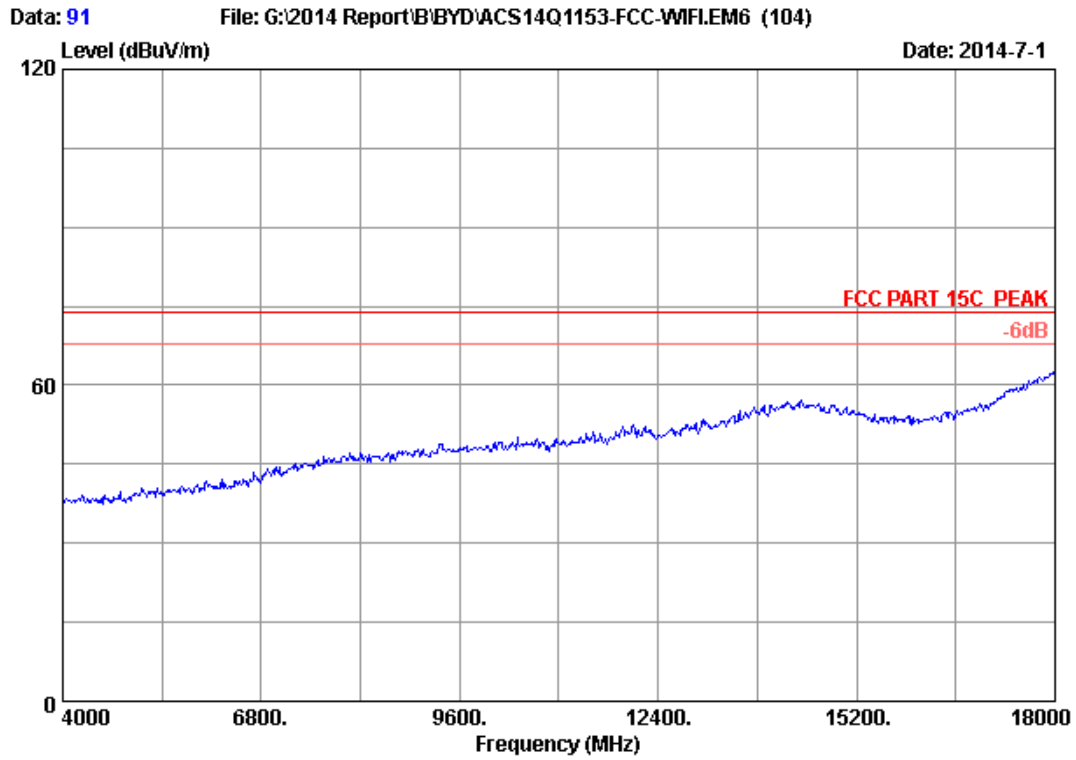

Site no. : 3m Chamber Data no. : 91
Dis. / Ant. : 3m 2013 3115 (4580) Ant. pol. : VERTICAL
Limit : FCC PART 15C PEAK
Env. / Ins. : 24°C/56% Engineer : Kevin_Hu
EUT : Tablet PC
Power Rating : DC 5V From Adapter Input AC 120V/60Hz
Test Mode : IEEE802.11nHT40 2437MHz Tx Mode
M/N : WT7-C

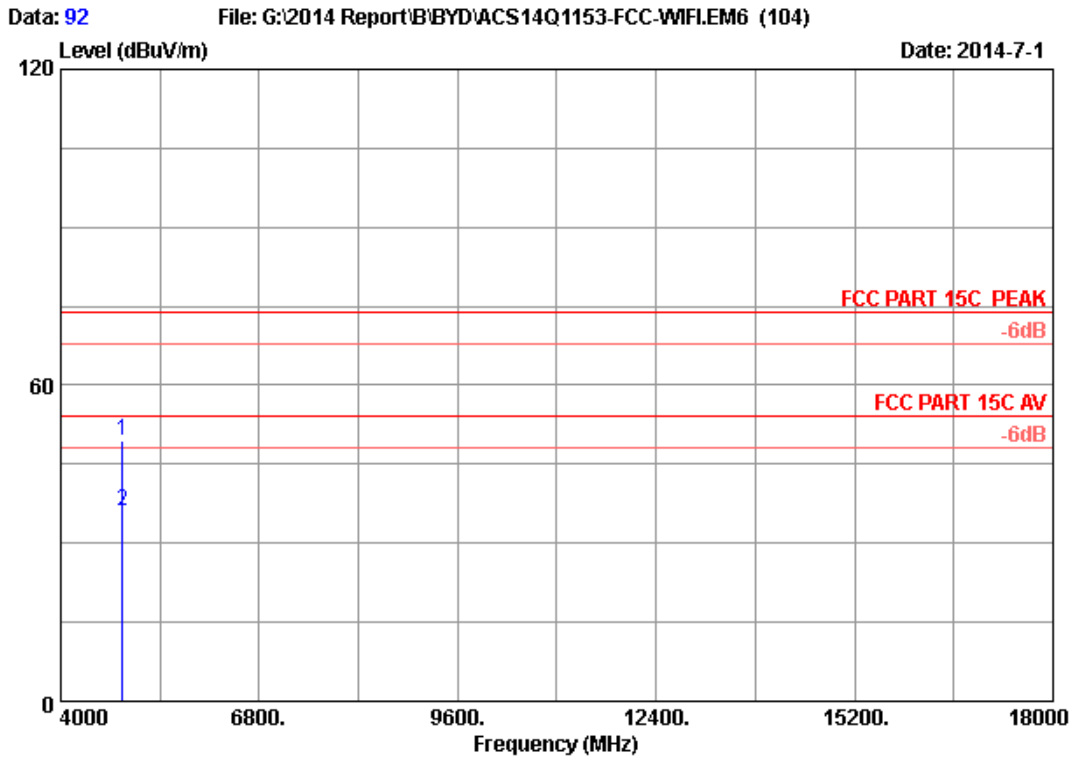

Site no. : 3m Chamber Data no. : 92
 Dis. / Ant. : 3m 2013 3115 (4580) Ant. pol. : VERTICAL
 Limit : FCC PART 15C PEAK
 Env. / Ins. : 24°C/56% Engineer : Kevin_Hu
 EUT : Tablet PC
 Power Rating : DC 5V From Adapter Input AC 120V/60Hz
 Test Mode : IEEE802.11nHT40 2437MHz Tx Mode
 M/N : WT7-C

No.	Freq. (MHz)	Ant. Factor (dB/m)	Cable Loss (dB)	AMP factor (dB)	Reading (dBUV)	Emission			Remark
						Level (dBUV/m)	Limits (dBUV/m)	Margin (dB)	
1	4874.000	32.97	8.63	35.70	43.61	49.51	74.00	24.49	Peak
2	4874.000	32.97	8.63	35.70	30.26	36.16	54.00	17.84	Average

Remarks: 1. Emission Level= Antenna Factor + Cable Loss + Reading - Amp Factor
 2. The emission levels that are 20dB below the official limit are not reported.

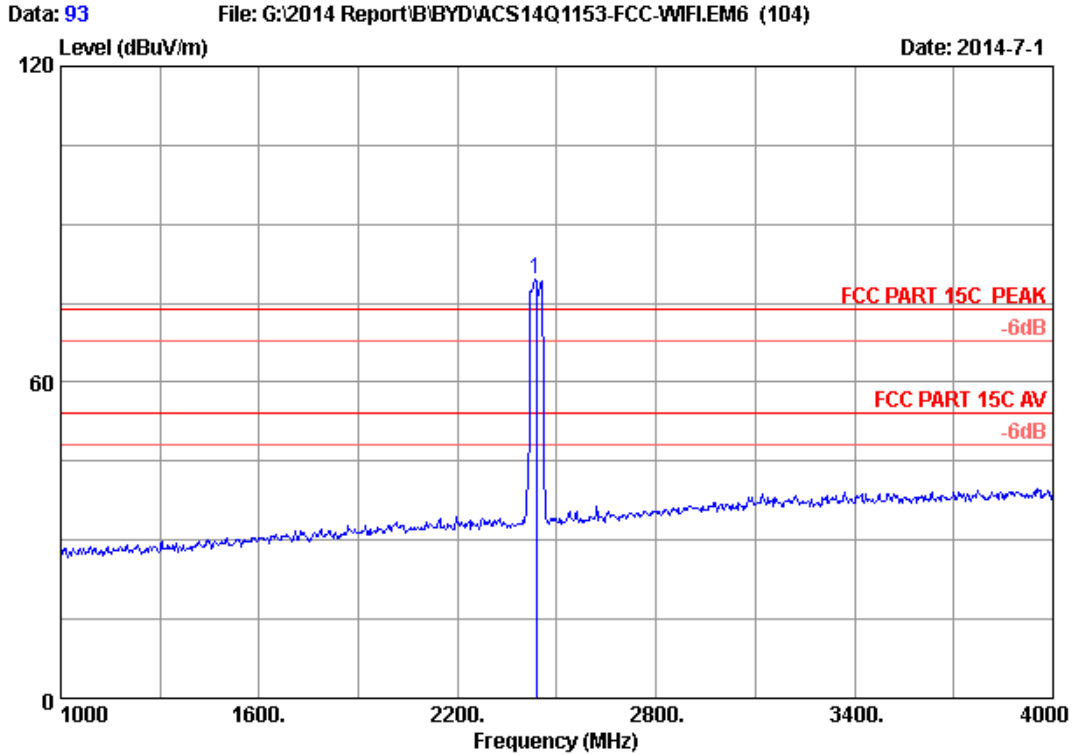

Site no. : 3m Chamber Data no. : 93
 Dis. / Ant. : 3m 2013 3115 (4580) Ant. pol. : VERTICAL
 Limit : FCC PART 15C PEAK
 Env. / Ins. : 24°C/56% Engineer : Kevin_Hu
 EUT : Tablet PC
 Power Rating : DC 5V From Adapter Input AC 120V/60Hz
 Test Mode : IEEE802.11nHT40 2437MHz Tx Mode
 M/N : WT7-C

No.	Freq. (MHz)	Ant. Factor (dB/m)	Cable Loss (dB)	AMP factor (dB)	Reading (dBuV)	Emission			Remark
						Level (dBuV/m)	Limits (dBuV/m)	Margin (dB)	
1	2437.000	28.26	5.85	35.70	81.05	79.46	74.00	-5.46	Peak

Remarks: 1. Emission Level= Antenna Factor + Cable Loss + Reading
 -Amp Factor
 2. The emission levels that are 20dB below the official
 limit are not reported.

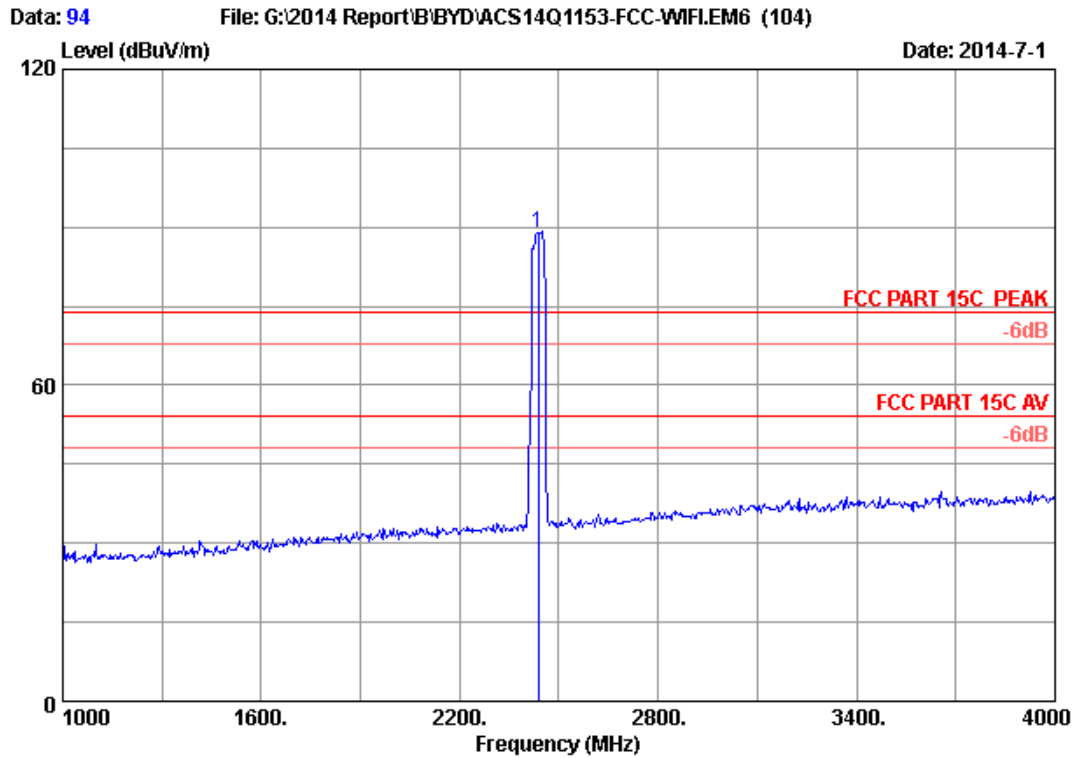

Site no. : 3m Chamber Data no. : 94
 Dis. / Ant. : 3m 2013 3115 (4580) Ant. pol. : HORIZONTAL
 Limit : FCC PART 15C PEAK
 Env. / Ins. : 24°C/56% Engineer : Kevin_Hu
 EUT : Tablet PC
 Power Rating : DC 5V From Adapter Input AC 120V/60Hz
 Test Mode : IEEE802.11nHT40 2437MHz Tx Mode
 M/N : WT7-C

No.	Freq. (MHz)	Ant. Factor (dB/m)	Cable Loss (dB)	AMP factor (dB)	Reading (dBUV)	Emission			Remark
						Level (dBUV/m)	Limits (dBUV/m)	Margin (dB)	
1	2437.000	28.26	5.85	35.70	90.63	89.04	74.00	-15.04	Peak

Remarks: 1. Emission Level= Antenna Factor + Cable Loss + Reading
 -Amp Factor
 2. The emission levels that are 20dB below the official
 limit are not reported.

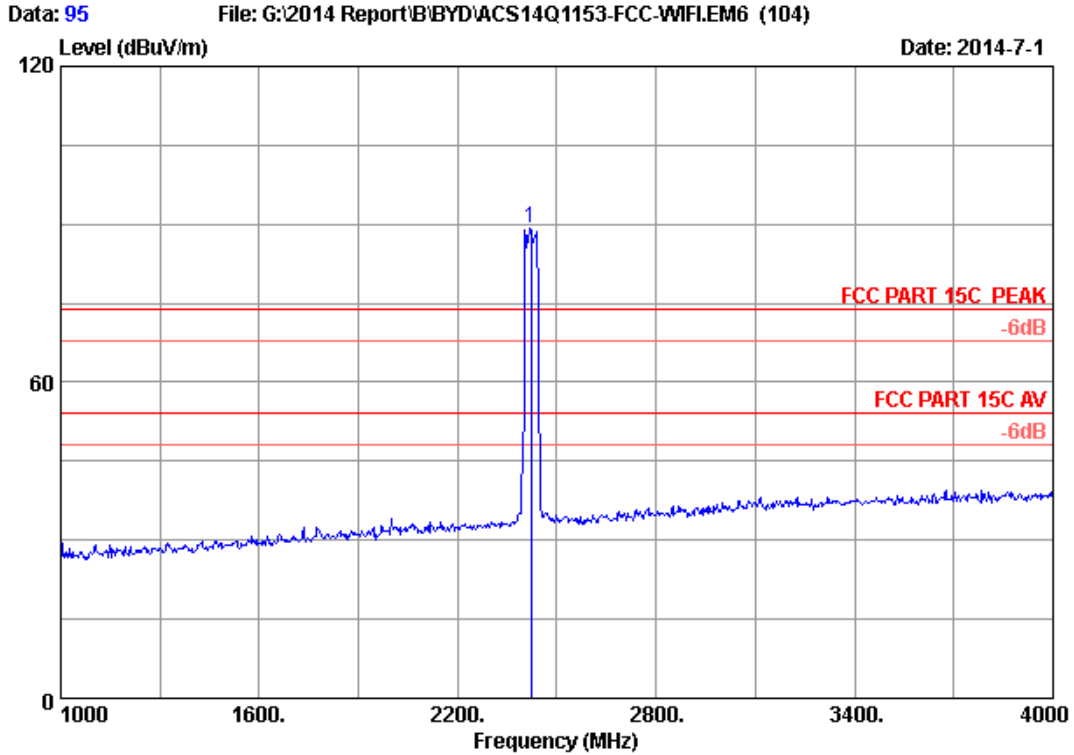

Site no. : 3m Chamber Data no. : 95
 Dis. / Ant. : 3m 2013 3115 (4580) Ant. pol. : HORIZONTAL
 Limit : FCC PART 15C PEAK
 Env. / Ins. : 24°C/56% Engineer : Kevin_Hu
 EUT : Tablet PC
 Power Rating : DC 5V From Adapter Input AC 120V/60Hz
 Test Mode : IEEE802.11nHT40 2422MHz Tx Mode
 M/N : WT7-C

No.	Freq. (MHz)	Ant. Factor (dB/m)	Cable Loss (dB)	AMP factor (dB)	Reading (dBuV)	Emission			Remark
						Level (dBuV/m)	Limits (dBuV/m)	Margin (dB)	
1	2422.000	28.23	5.83	35.70	91.05	89.41	74.00	-15.41	Peak

Remarks: 1. Emission Level= Antenna Factor + Cable Loss + Reading
 -Amp Factor
 2. The emission levels that are 20dB below the official
 limit are not reported.

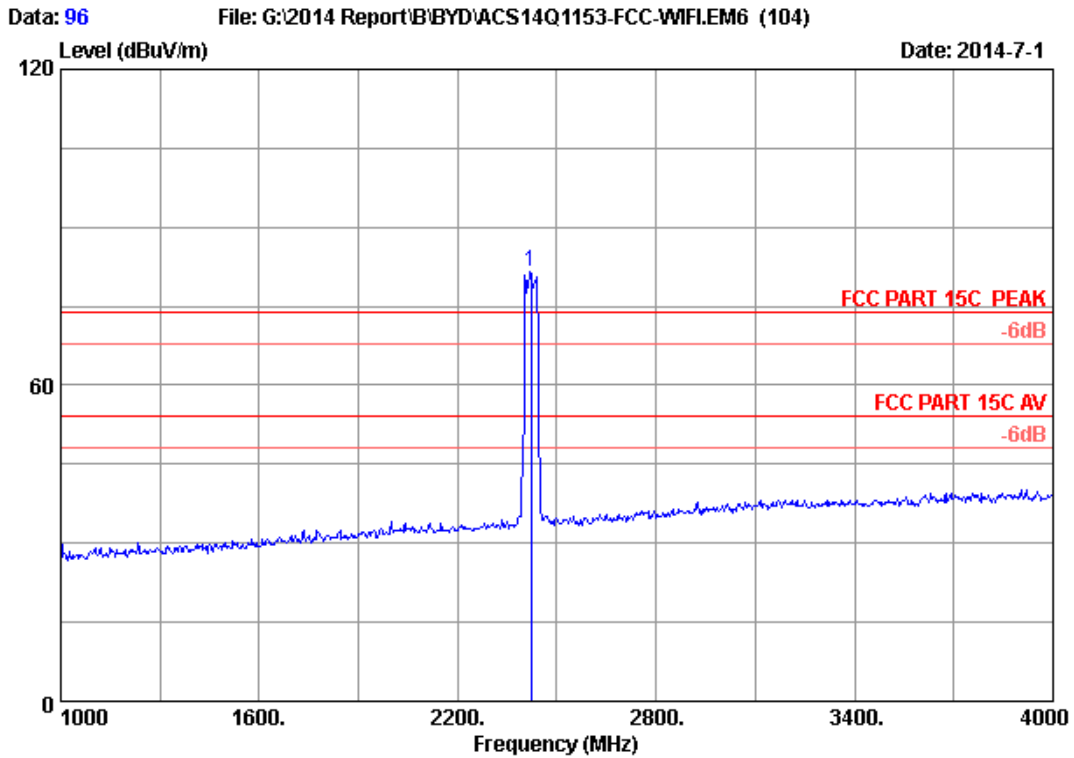

Site no. : 3m Chamber Data no. : 96
 Dis. / Ant. : 3m 2013 3115 (4580) Ant. pol. : VERTICAL
 Limit : FCC PART 15C PEAK
 Env. / Ins. : 24°C/56% Engineer : Kevin_Hu
 EUT : Tablet PC
 Power Rating : DC 5V From Adapter Input AC 120V/60Hz
 Test Mode : IEEE802.11nHT40 2422MHz Tx Mode
 M/N : WT7-C

No.	Freq. (MHz)	Ant. Factor (dB/m)	Cable Loss (dB)	AMP factor (dB)	Reading (dBUV)	Emission			Remark
						Level (dBUV/m)	Limits (dBUV/m)	Margin (dB)	
1	2422.000	28.23	5.83	35.70	83.05	81.41	74.00	-7.41	Peak

Remarks: 1. Emission Level= Antenna Factor + Cable Loss + Reading
 -Amp Factor
 2. The emission levels that are 20dB below the official
 limit are not reported.

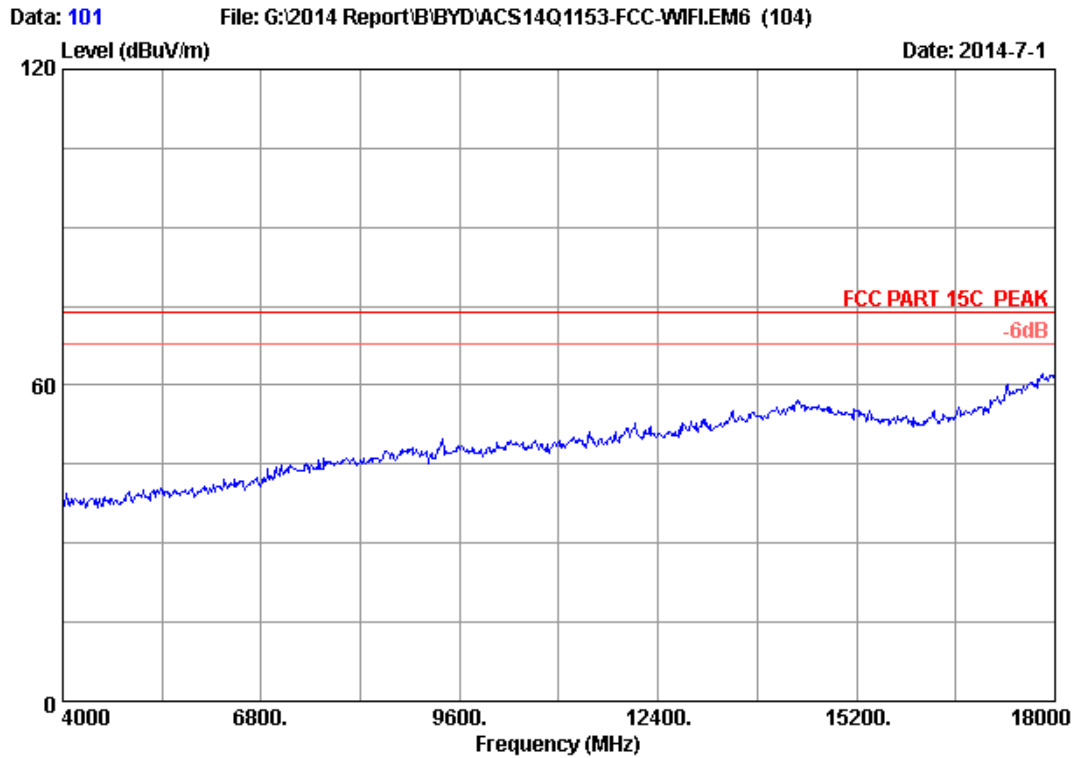

Site no. : 3m Chamber Data no. : 101
Dis. / Ant. : 3m 2013 3115 (4580) Ant. pol. : HORIZONTAL
Limit : FCC PART 15C PEAK
Env. / Ins. : 24°C/56% Engineer : Kevin_Hu
EUT : Tablet PC
Power Rating : DC 5V From Adapter Input AC 120V/60Hz
Test Mode : IEEE802.11nHT40 2422MHz Tx Mode
M/N : WT7-C

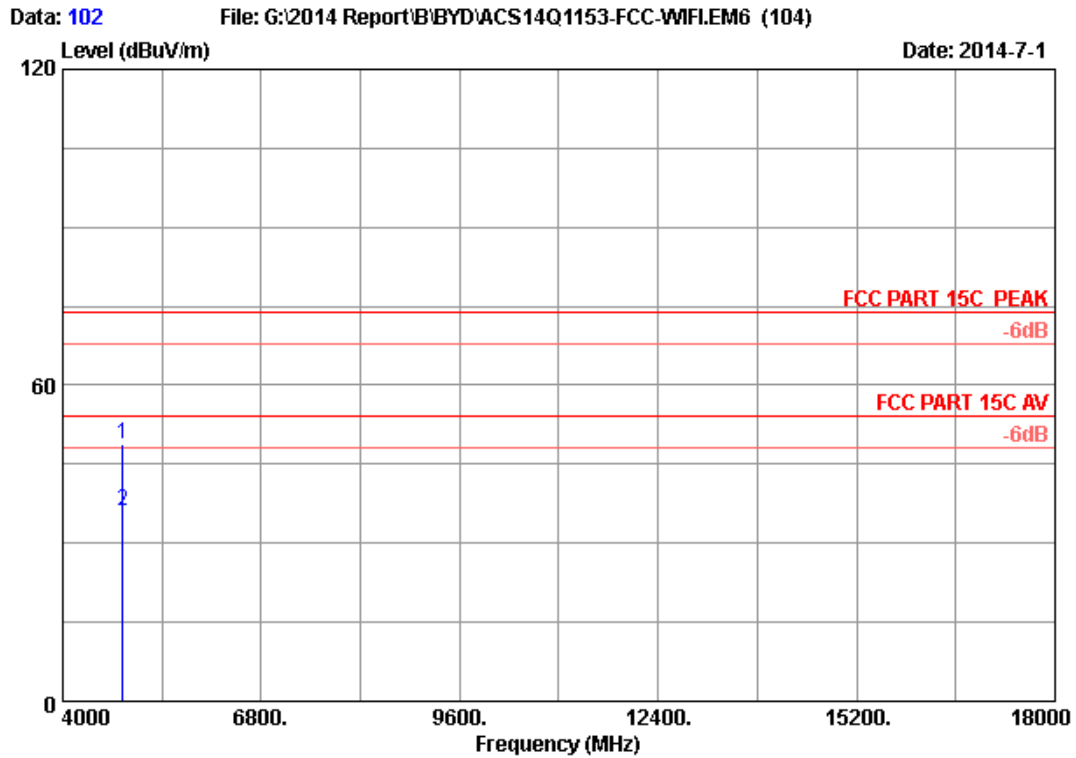

Site no. : 3m Chamber Data no. : 102
 Dis. / Ant. : 3m 2013 3115 (4580) Ant. pol. : HORIZONTAL
 Limit : FCC PART 15C PEAK
 Env. / Ins. : 24°C/56% Engineer : Kevin_Hu
 EUT : Tablet PC
 Power Rating : DC 5V From Adapter Input AC 120V/60Hz
 Test Mode : IEEE802.11nHT40 2422MHz Tx Mode
 M/N : WT7-C

No.	Freq. (MHz)	Ant. Factor (dB/m)	Cable Loss (dB)	AMP factor (dB)	Reading (dBUV)	Emission Level (dBUV/m)	Limits (dBUV/m)	Margin (dB)	Remark
1	4844.000	32.92	8.60	35.70	43.06	48.88	74.00	25.12	Peak
2	4844.000	32.92	8.60	35.70	30.25	36.07	54.00	17.93	Average

Remarks: 1. Emission Level= Antenna Factor + Cable Loss + Reading - Amp Factor
 2. The emission levels that are 20dB below the official limit are not reported.

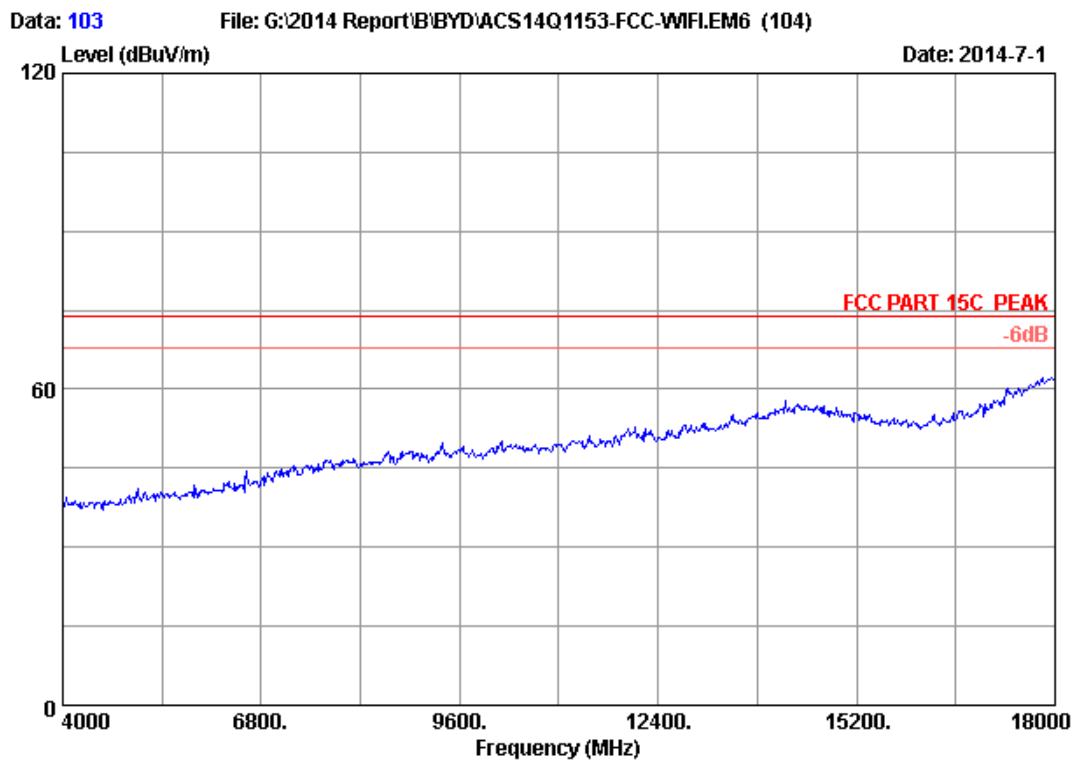

Site no. : 3m Chamber Data no. : 103
Dis. / Ant. : 3m 2013 3115 (4580) Ant. pol. : VERTICAL
Limit : FCC PART 15C PEAK
Env. / Ins. : 24°C/56% Engineer : Kevin_Hu
EUT : Tablet PC
Power Rating : DC 5V From Adapter Input AC 120V/60Hz
Test Mode : IEEE802.11nHT40 2422MHz Tx Mode
M/N : WT7-C

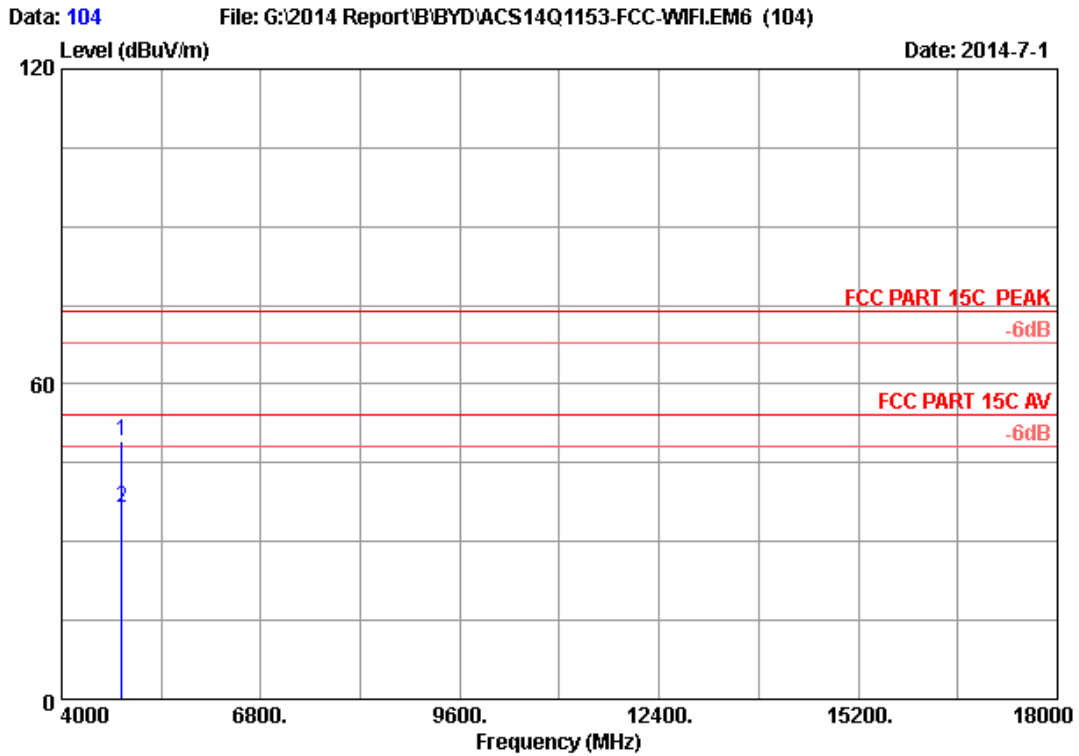

Site no. : 3m Chamber Data no. : 104
 Dis. / Ant. : 3m 2013 3115 (4580) Ant. pol. : VERTICAL
 Limit : FCC PART 15C PEAK
 Env. / Ins. : 24°C/56% Engineer : Kevin_Hu
 EUT : Tablet PC
 Power Rating : DC 5V From Adapter Input AC 120V/60Hz
 Test Mode : IEEE802.11nHT40 2422MHz Tx Mode
 M/N : WT7-C

No.	Freq. (MHz)	Ant. Factor (dB/m)	Cable Loss (dB)	AMP factor (dB)	Reading (dBuV)	Emission Level (dBuV/m)	Limits (dBuV/m)	Margin (dB)	Remark
1	4844.000	32.92	8.60	35.70	43.39	49.21	74.00	24.79	Peak
2	4844.000	32.92	8.60	35.70	30.68	36.50	54.00	17.50	Average

Remarks: 1. Emission Level= Antenna Factor + Cable Loss + Reading - Amp Factor
 2. The emission levels that are 20dB below the official limit are not reported.

5. CONDUCTED SPURIOUS EMISSIONS

5.1. Test Equipment

Item	Equipment	Manufacturer	Model No.	Serial No.	Last Cal.	Cal. Interval
1.	Spectrum Analyzer	Agilent	N9030A	MY51380221	Oct.31, 13	1Year
2.	Attenuator	Agilent	8491B	MY39262165	May.08,13	1 Year
3.	RF Cable	Hubersuhner	SUCOFLEX102	28618/2	May.08,13	1Year

5.2. Limit

In any 100kHz bandwidth outside the frequency bands in which the spread spectrum intentional radiator is operating, the radio frequency power that is produced by the intentional radiator shall be at least 20dB below that in the 100kHz bandwidth within the band that contains the highest level of the desired power.

5.3. Test Procedure

The transmitter output was connected to a spectrum analyzer, The resolution bandwidth is set to 100 kHz, The video bandwidth is set to 300 kHz and measure all the emissions detected.

Conducted emission test data:

Test Mode: IEEE 802.11b

Test CH1: 2412MHz

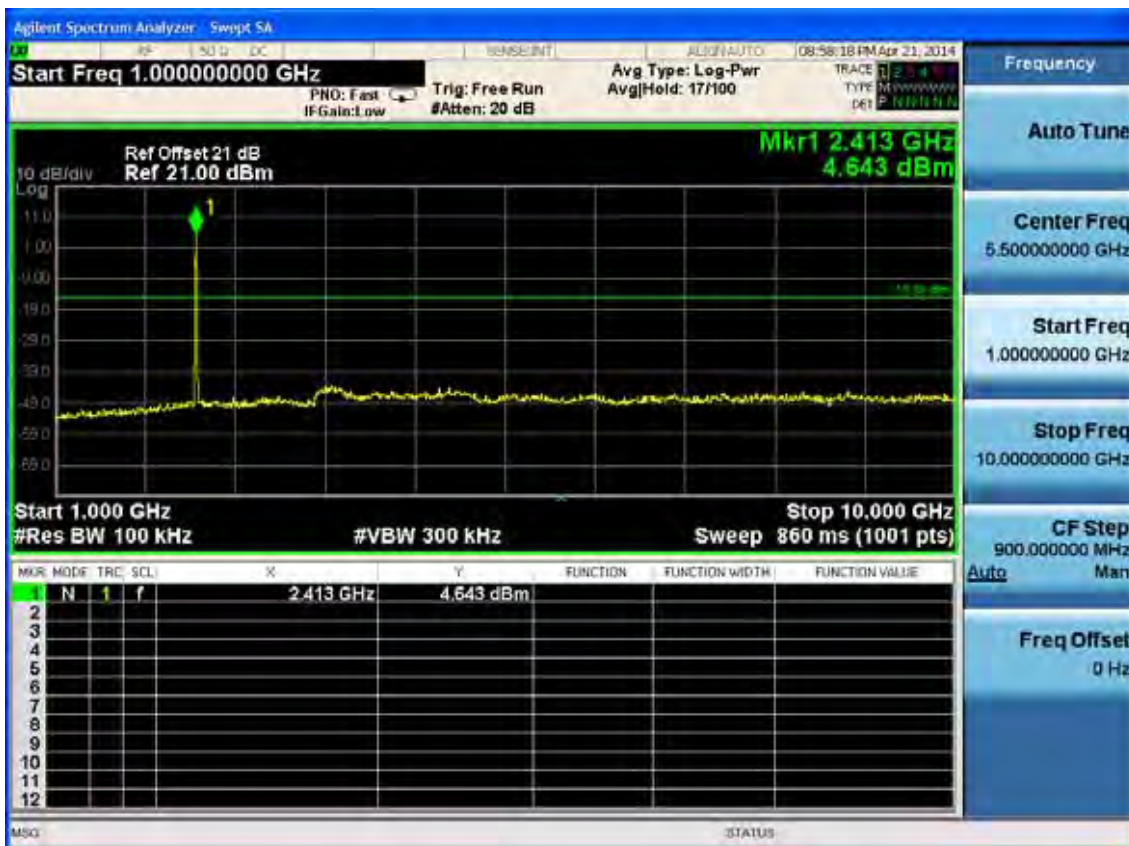

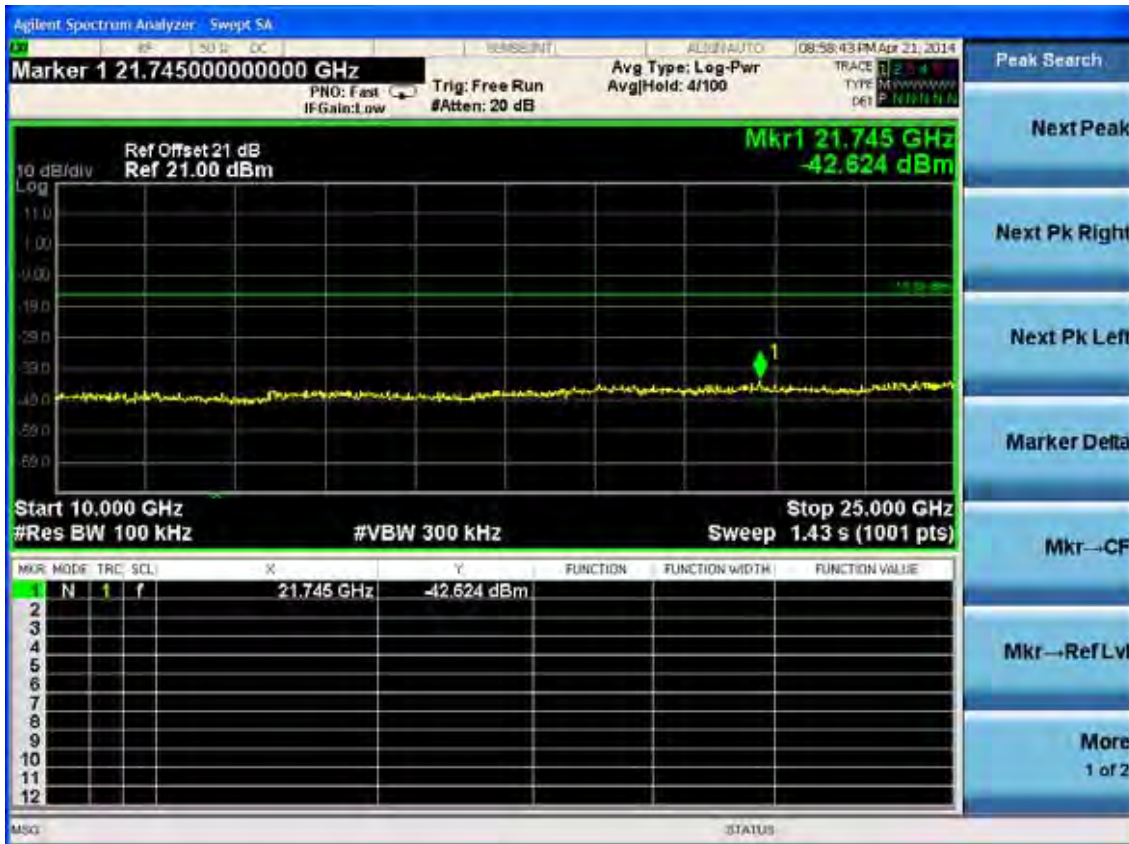
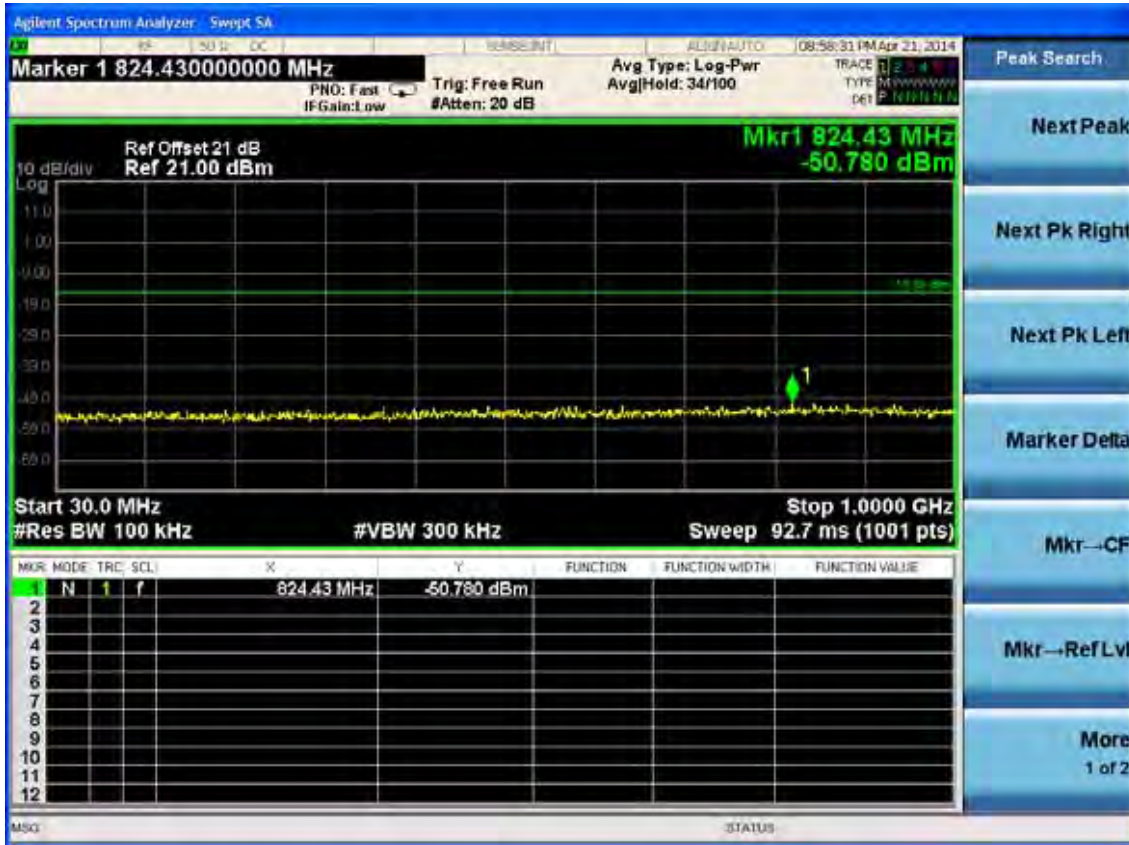

Test CH6: 2437MHz

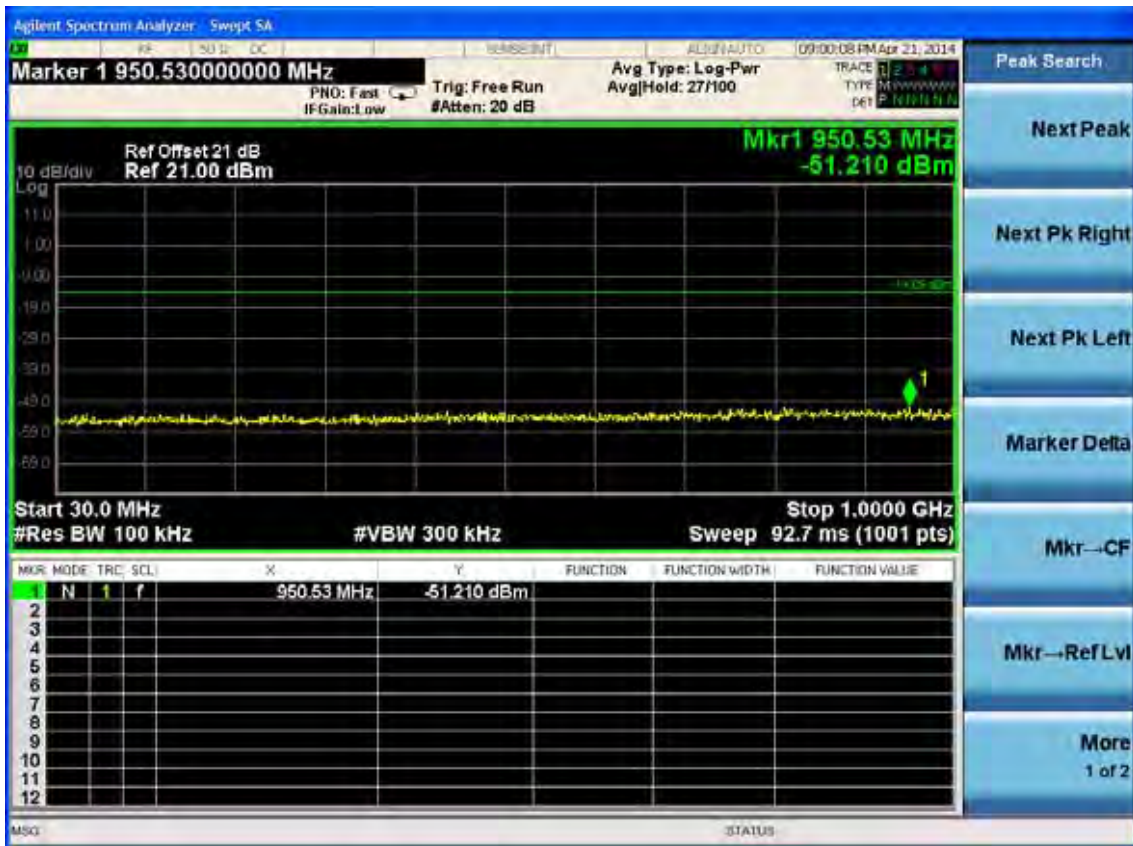
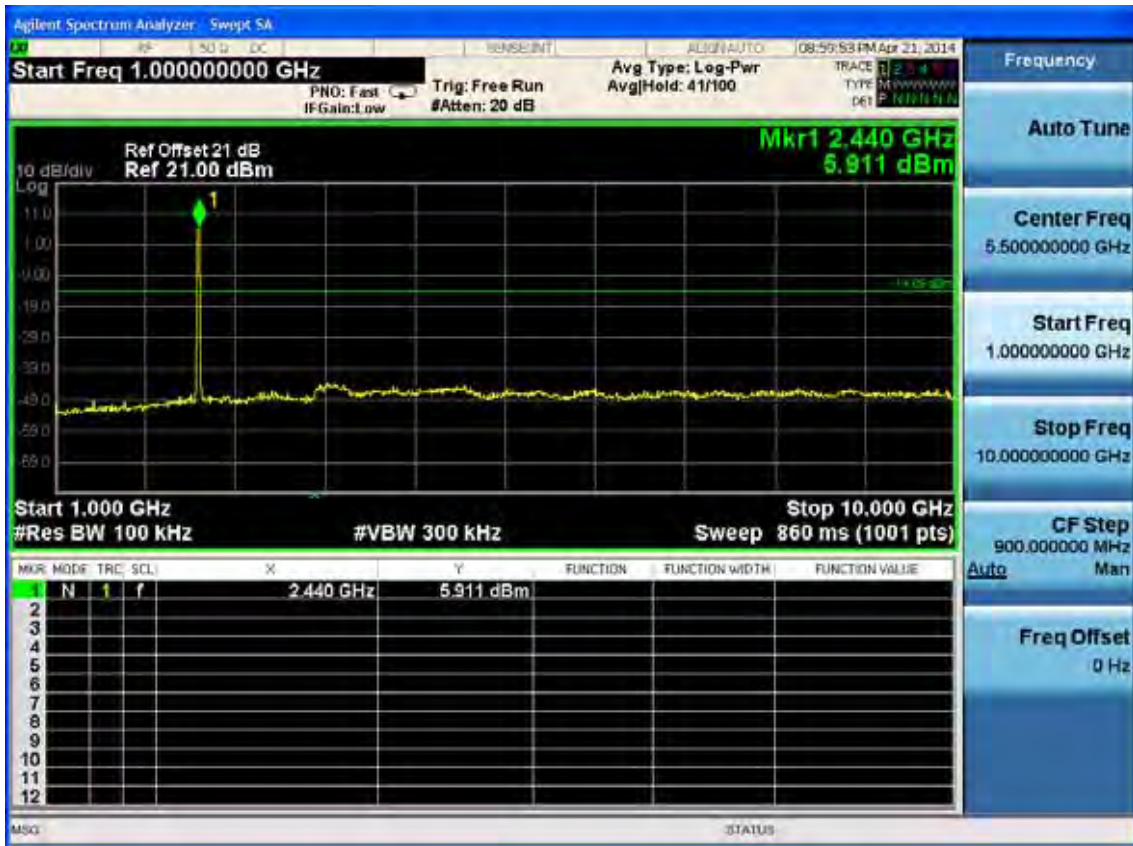

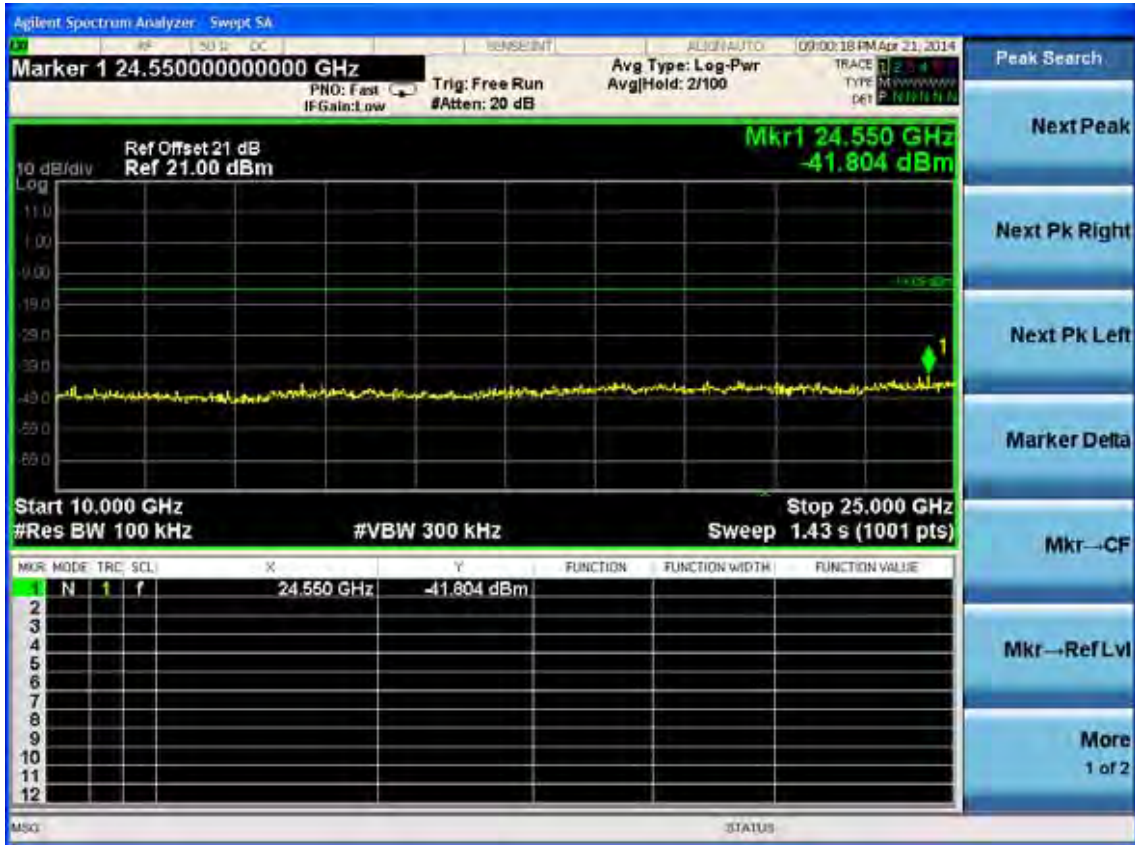

Test CH11: 2462MHz

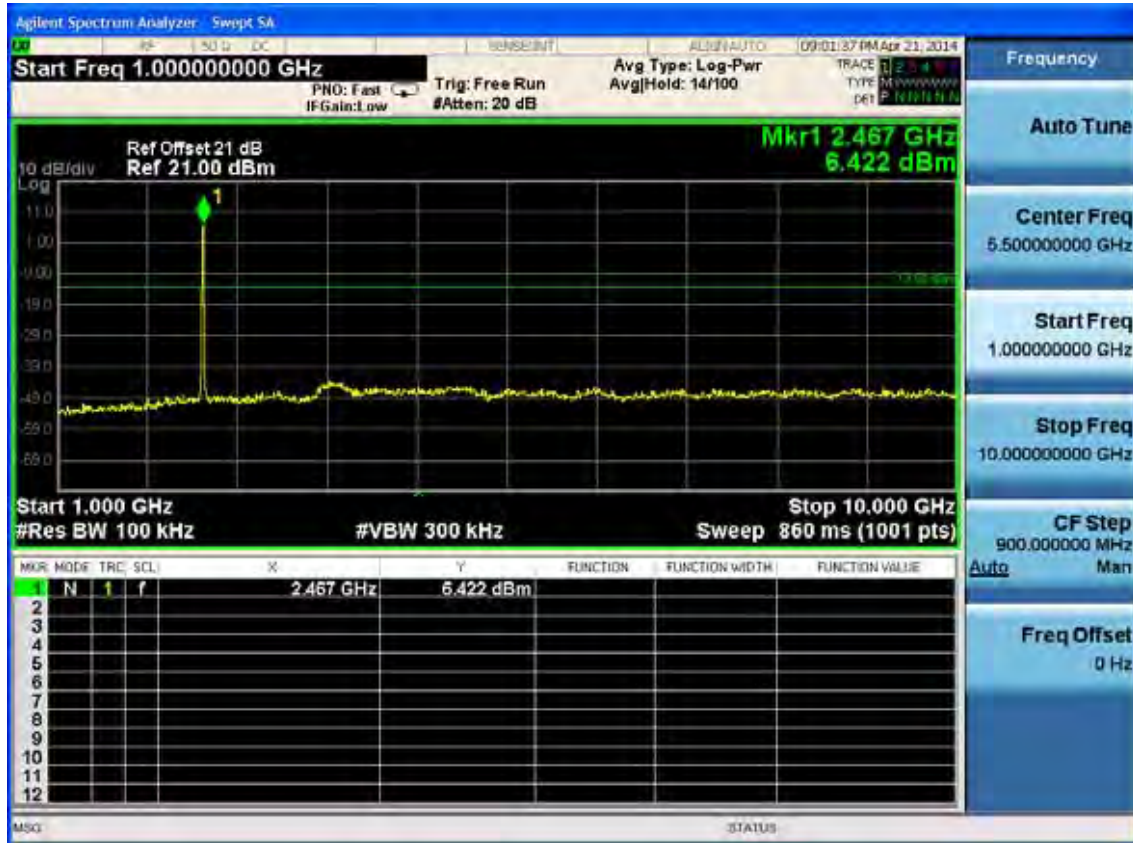

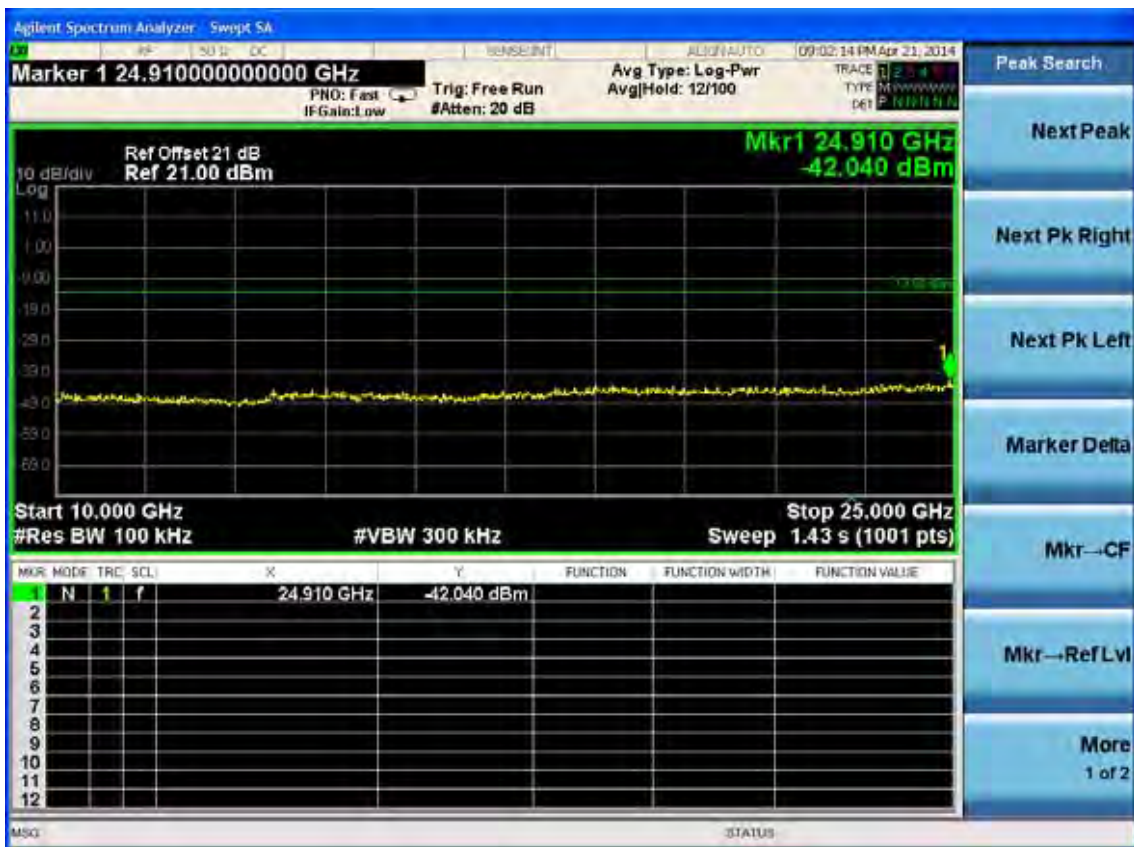
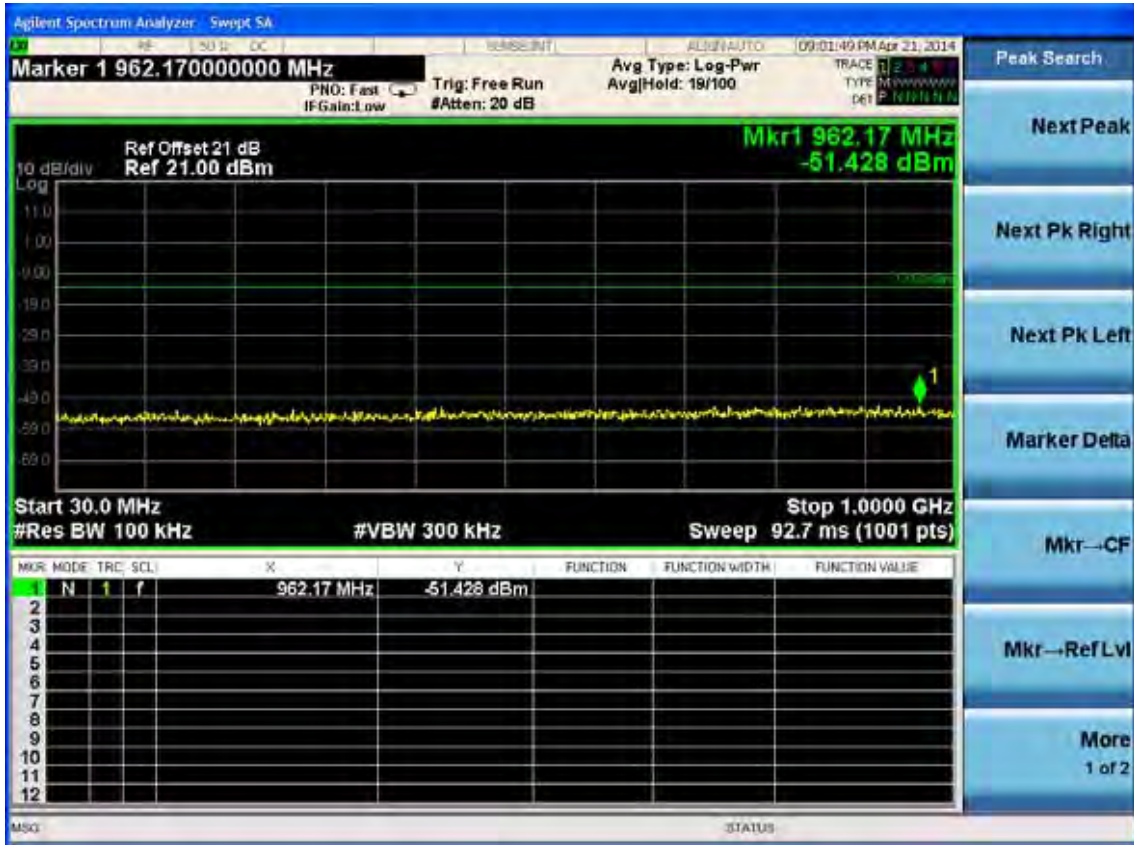



Test Mode: IEEE 802.11g
Test CH1: 2412MHz

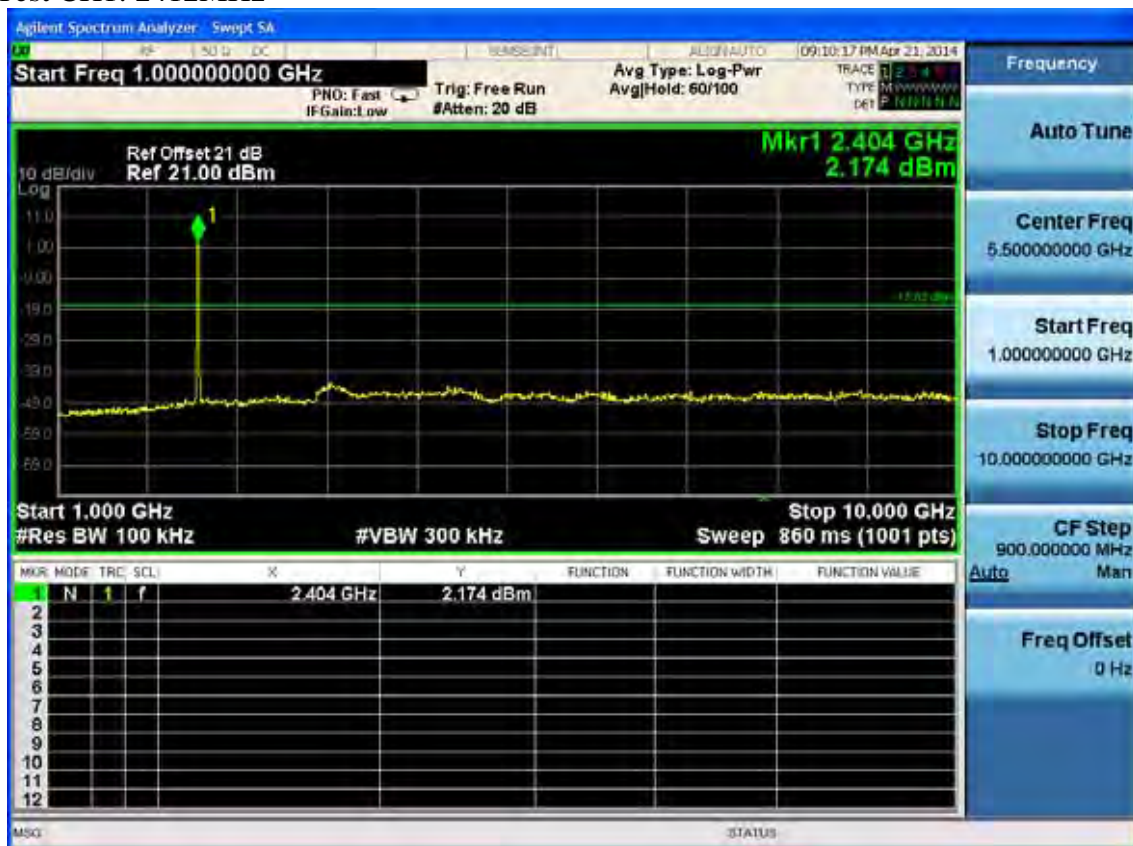

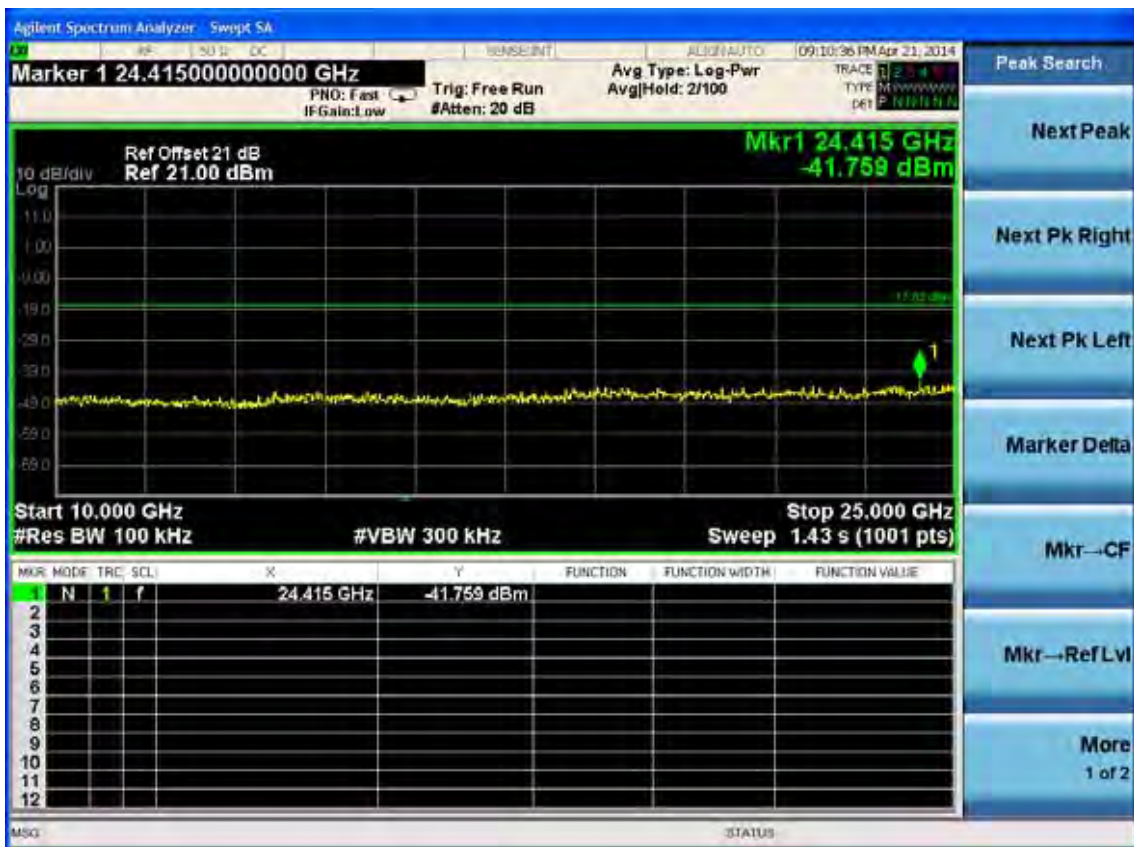
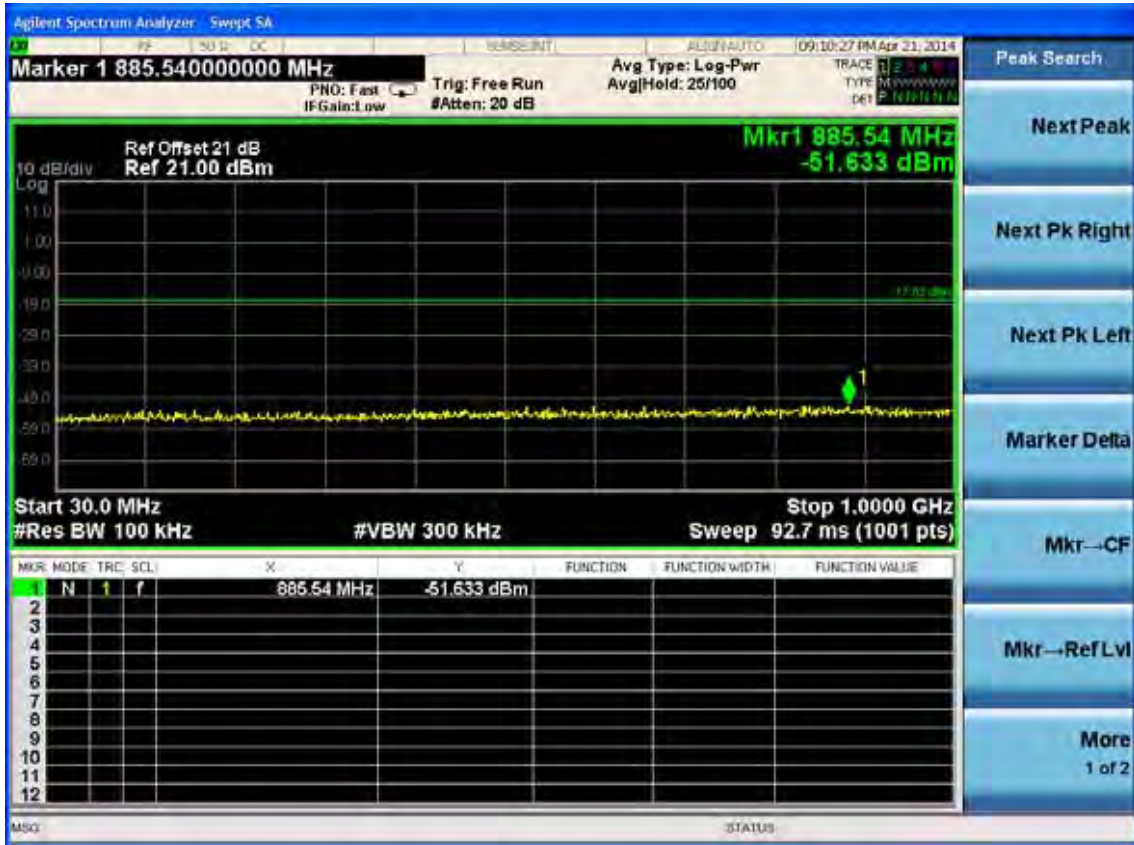



Test CH6: 2437MHz

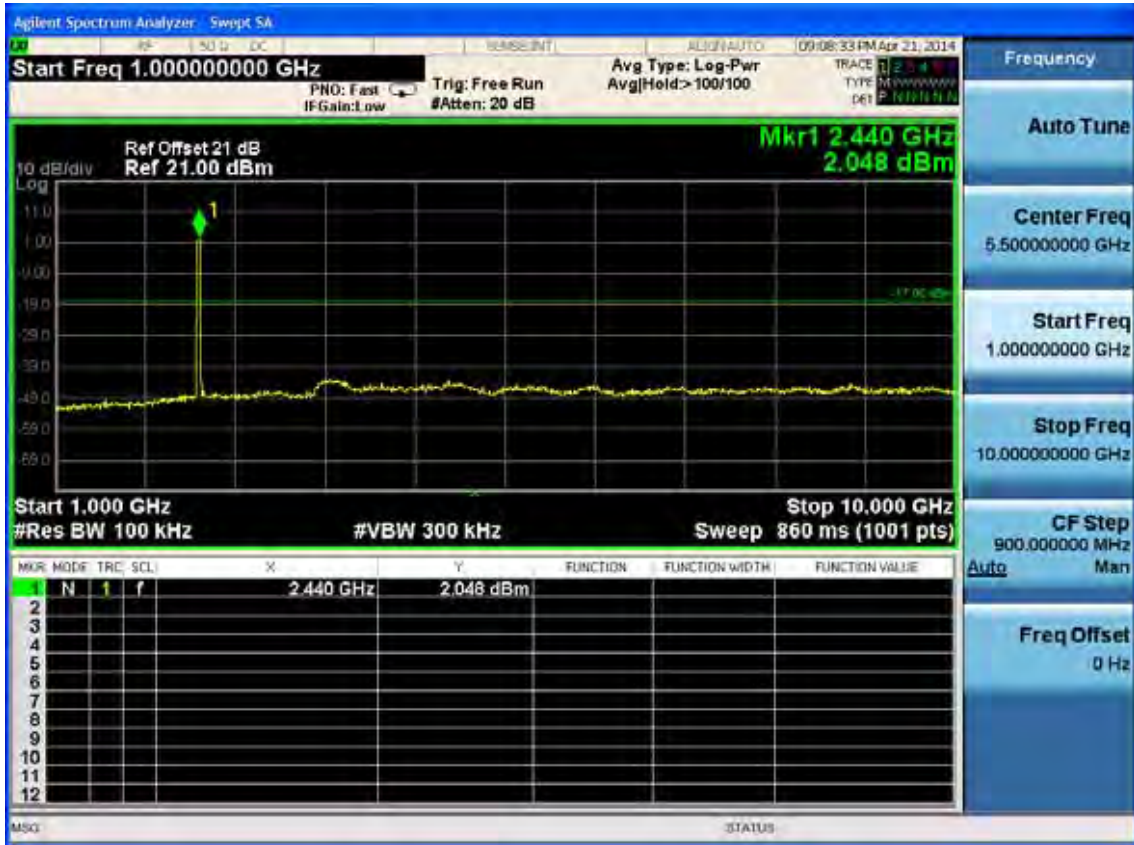

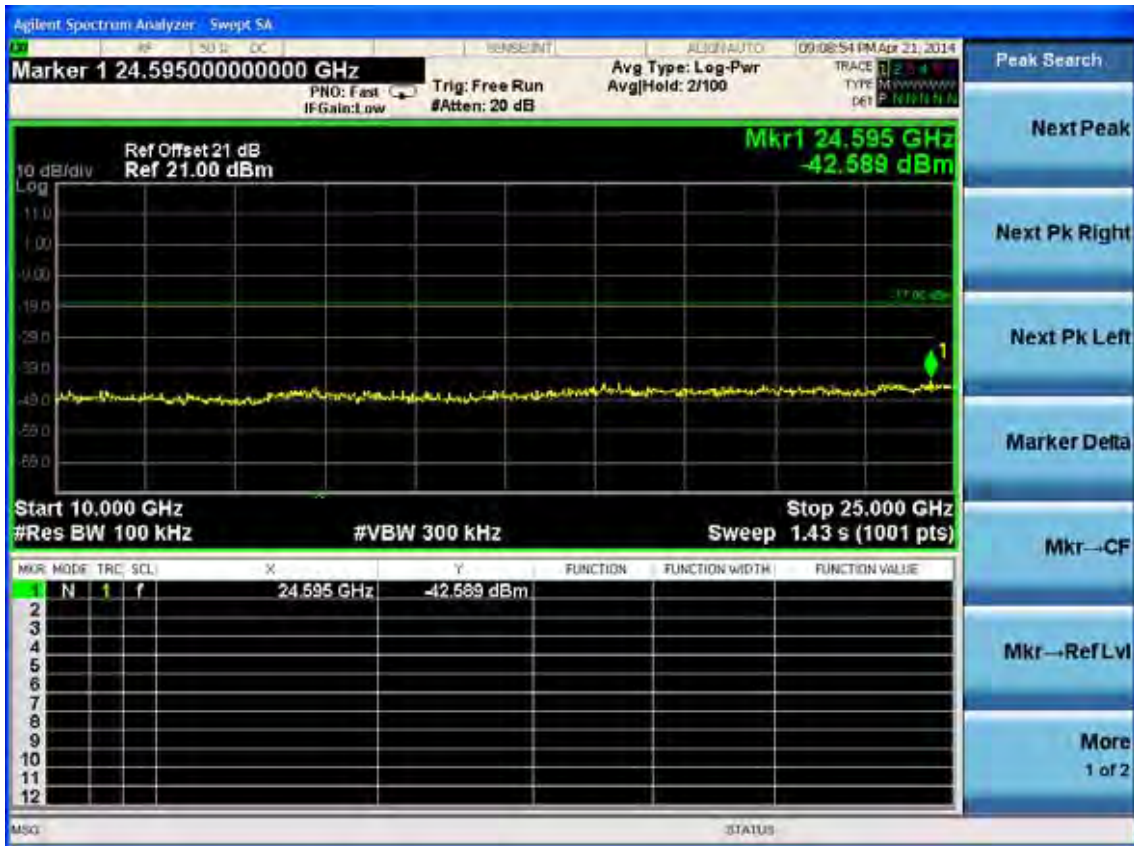
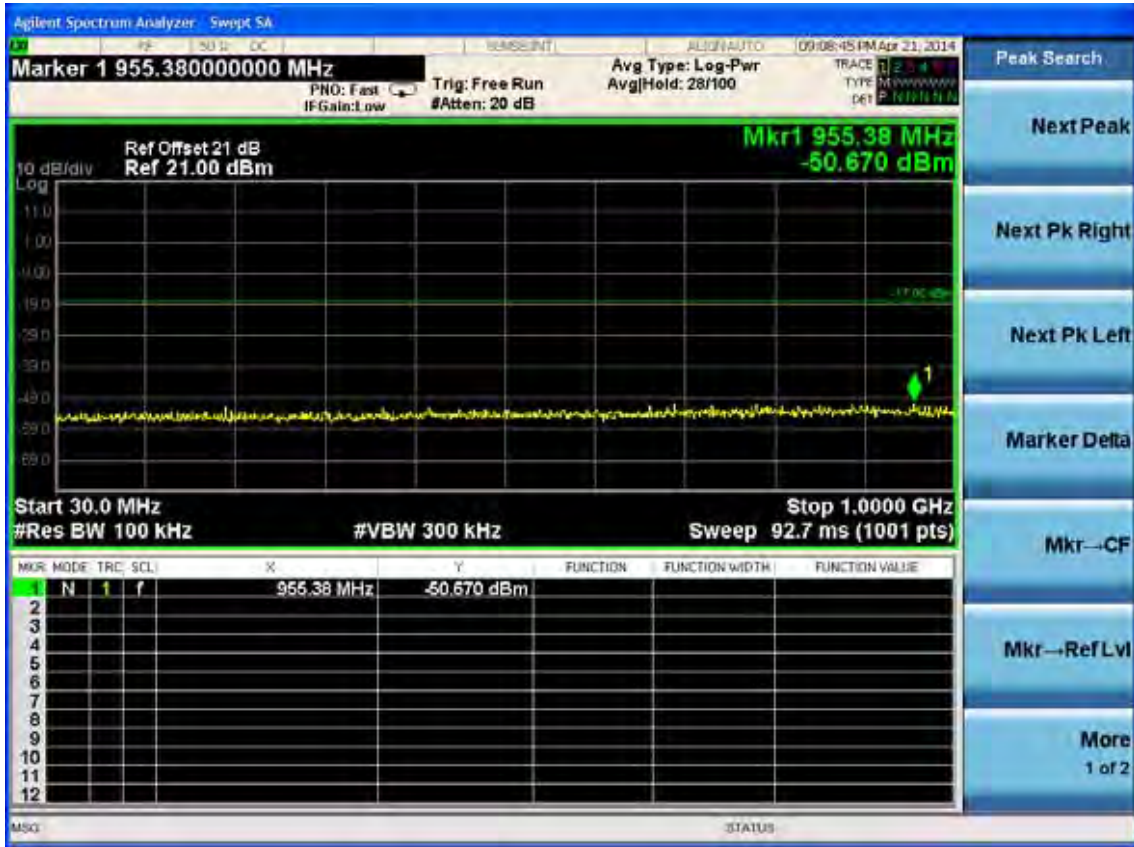

Test CH11: 2462MHz

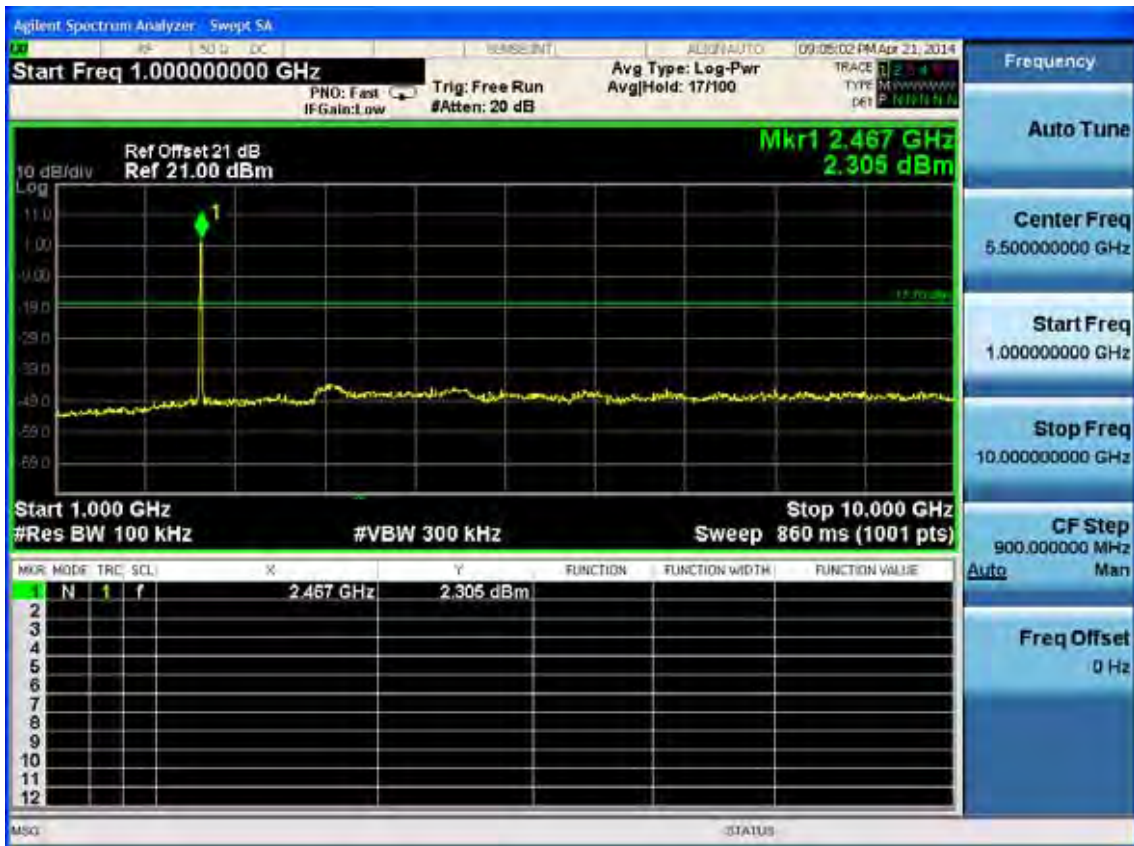

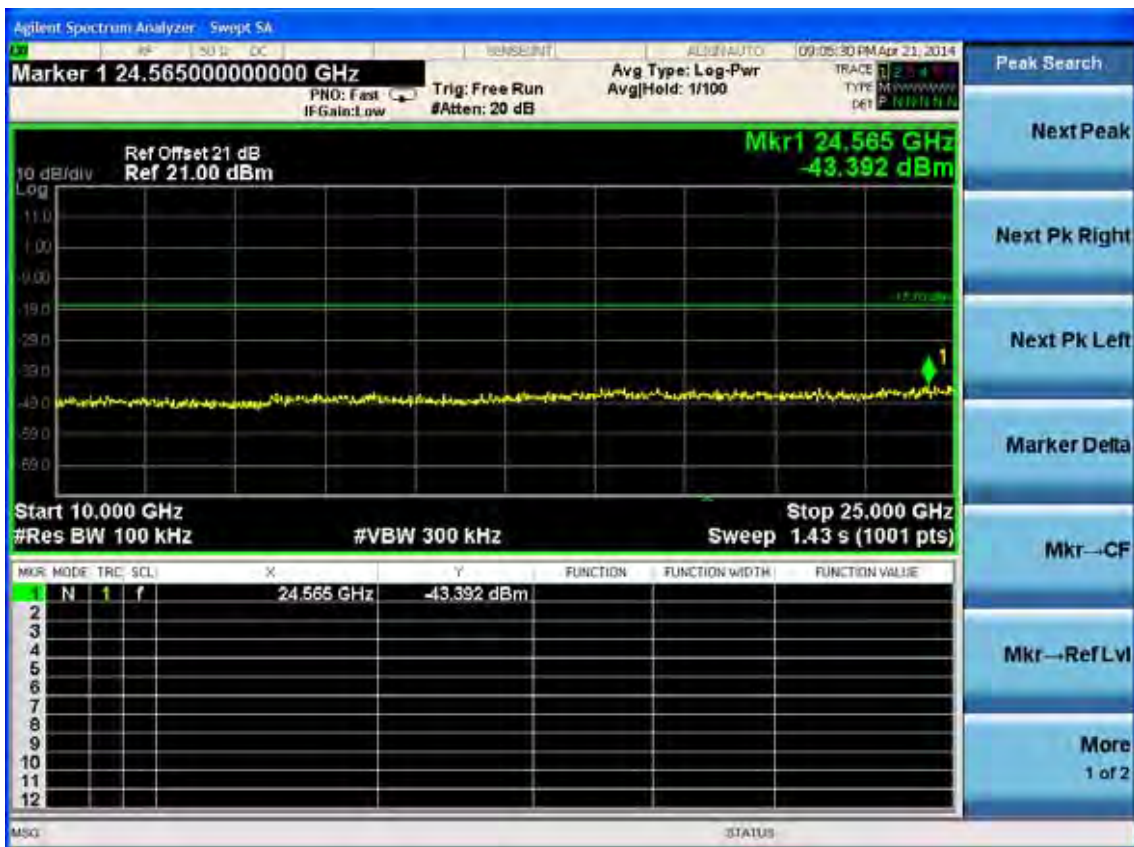
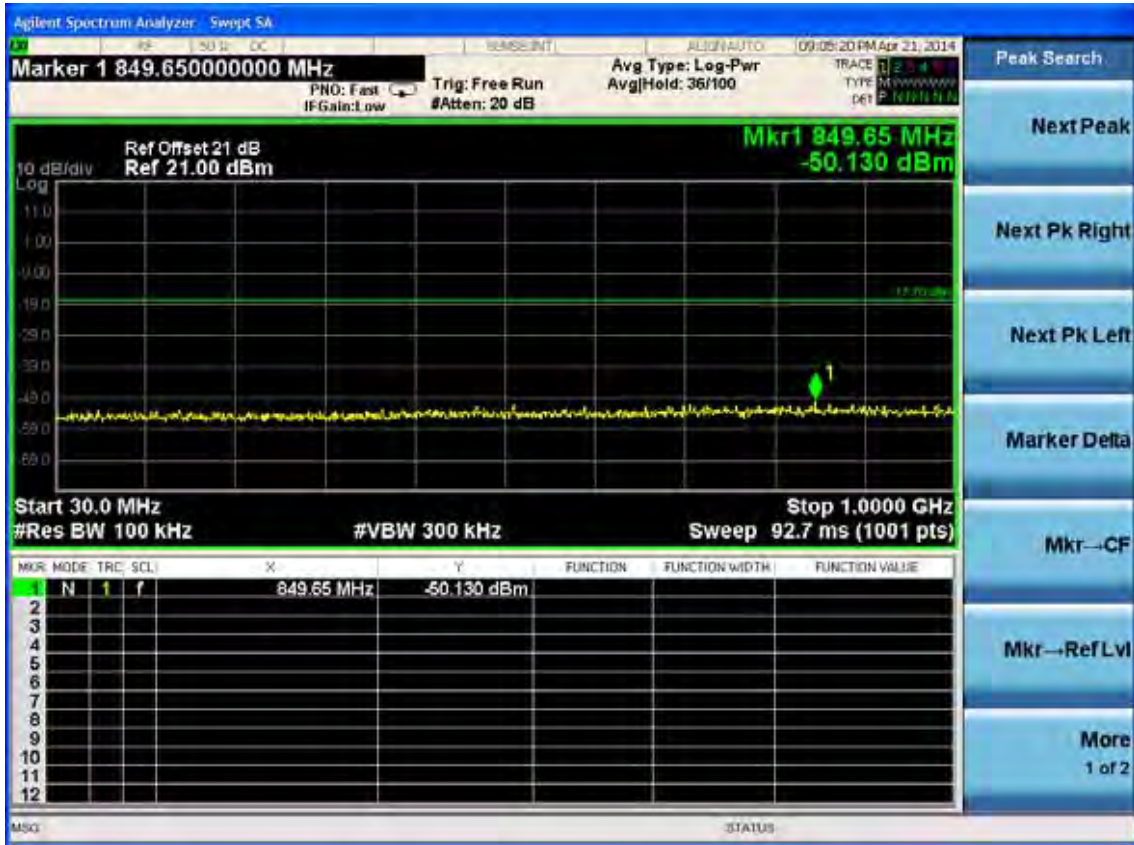

Test Mode: IEEE 802.11n HT20
 Test CH1: 2412MHz

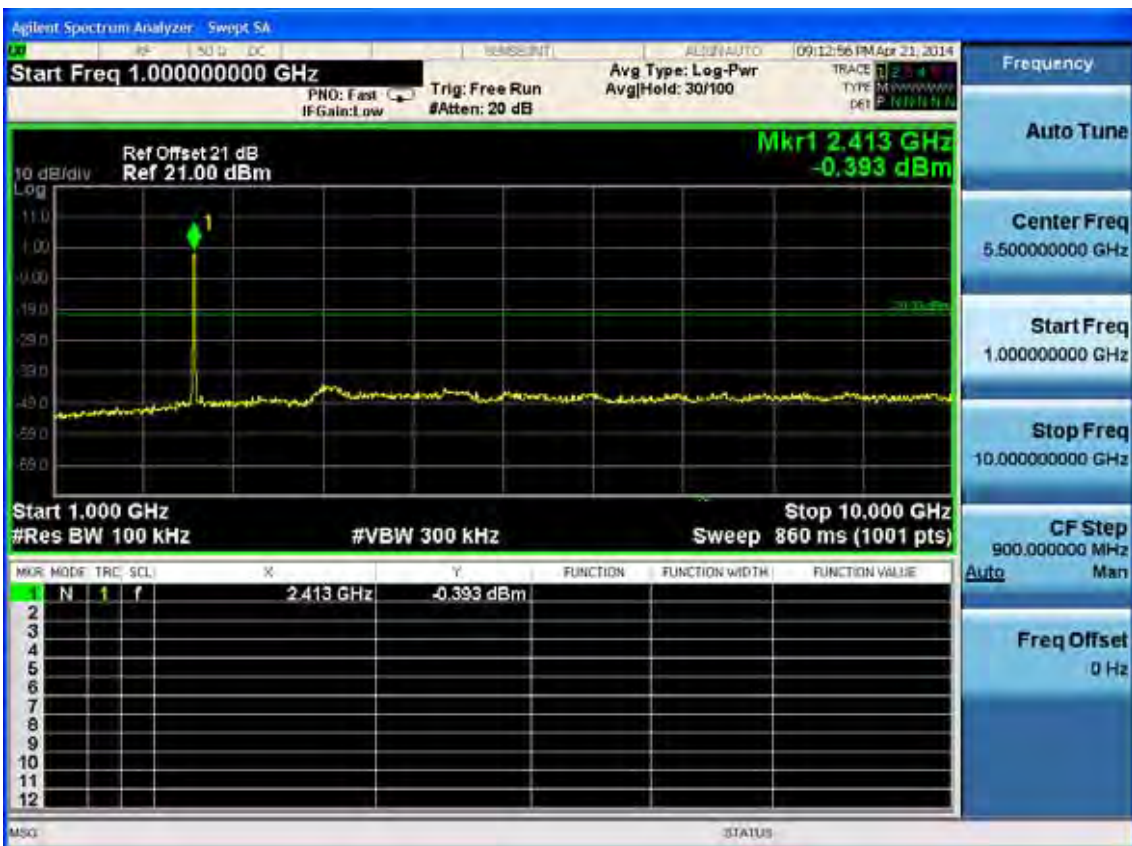

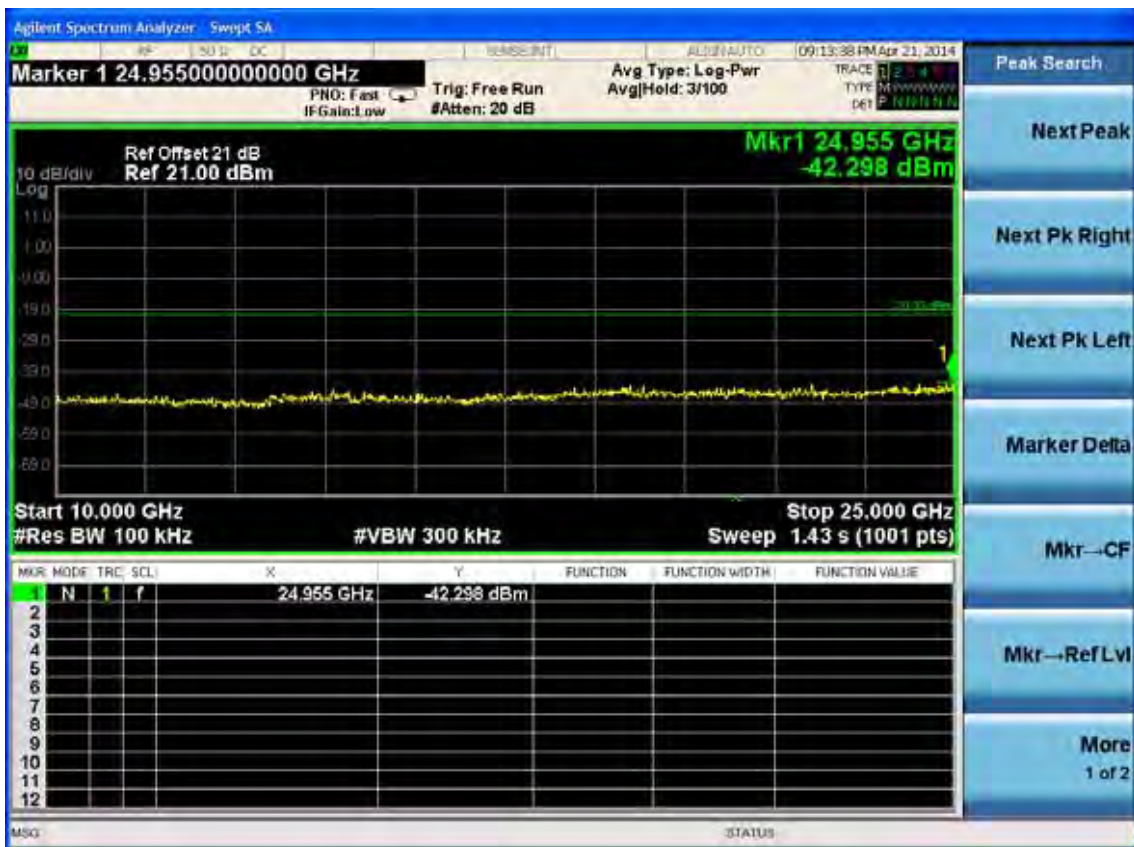
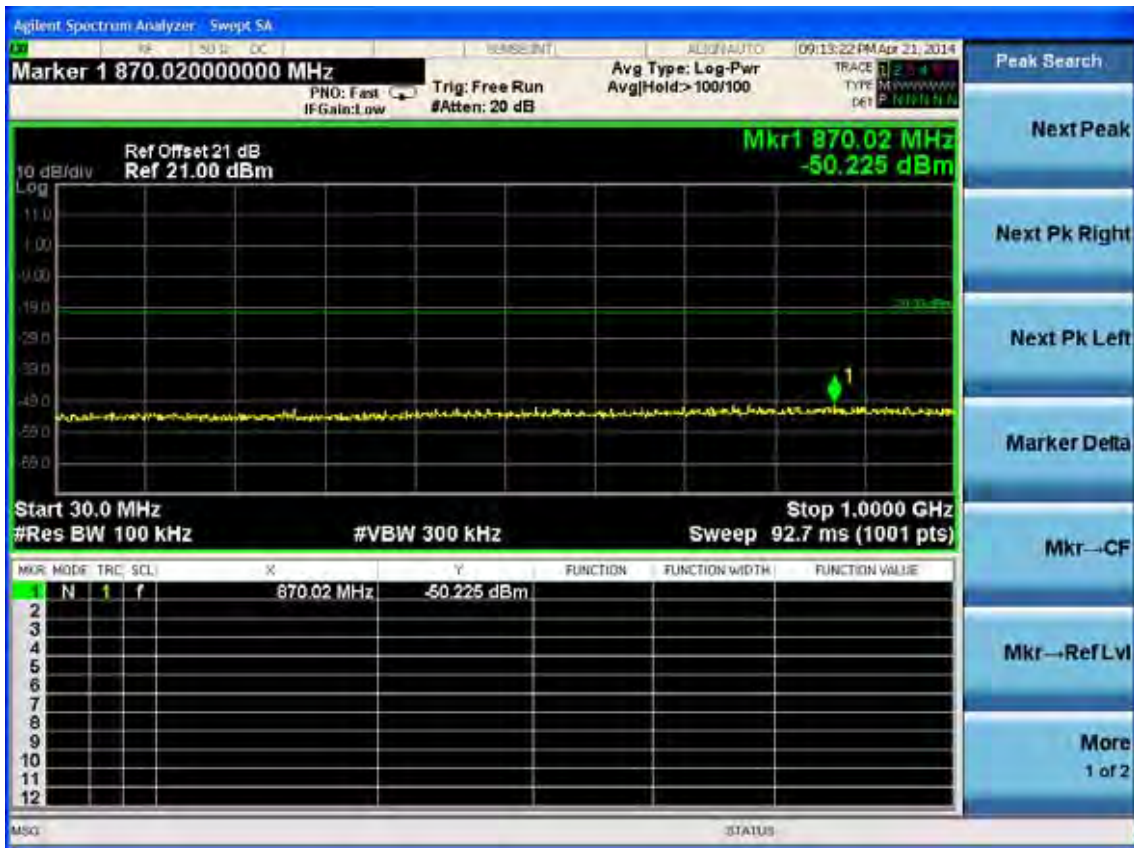

Test CH6: 2437MHz

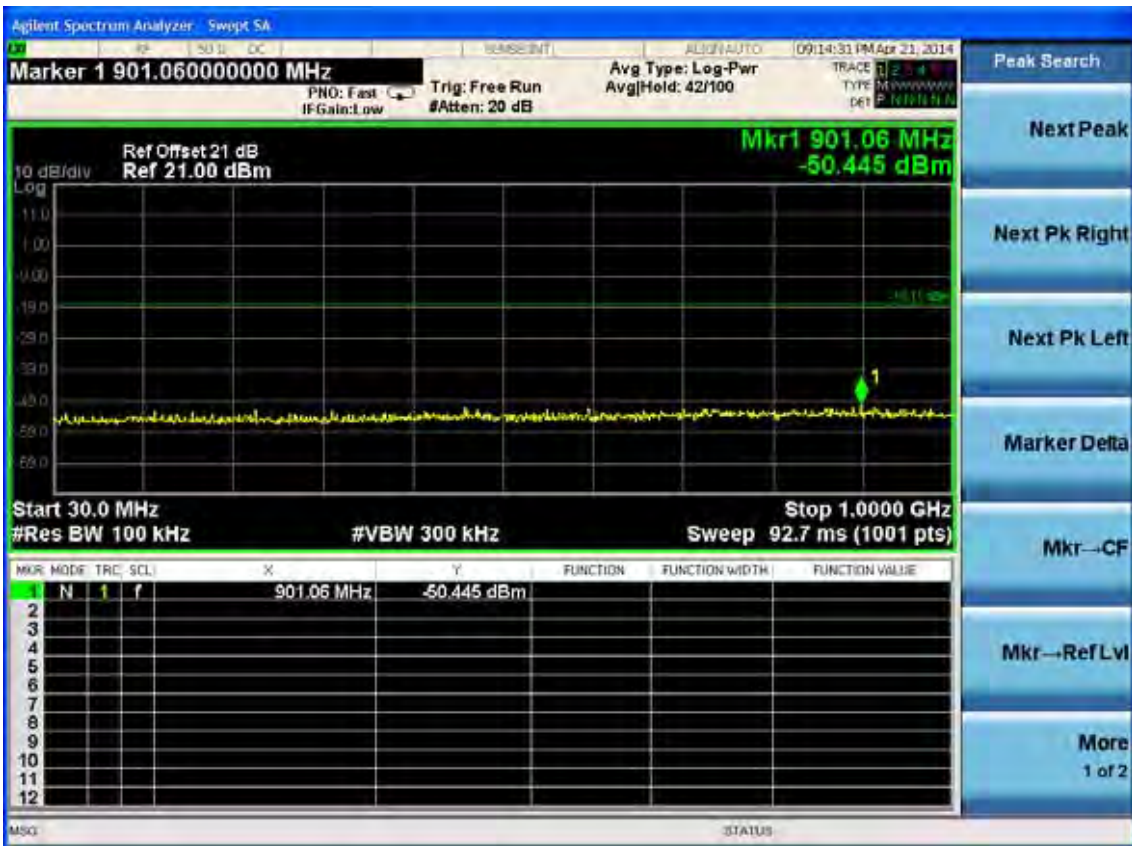
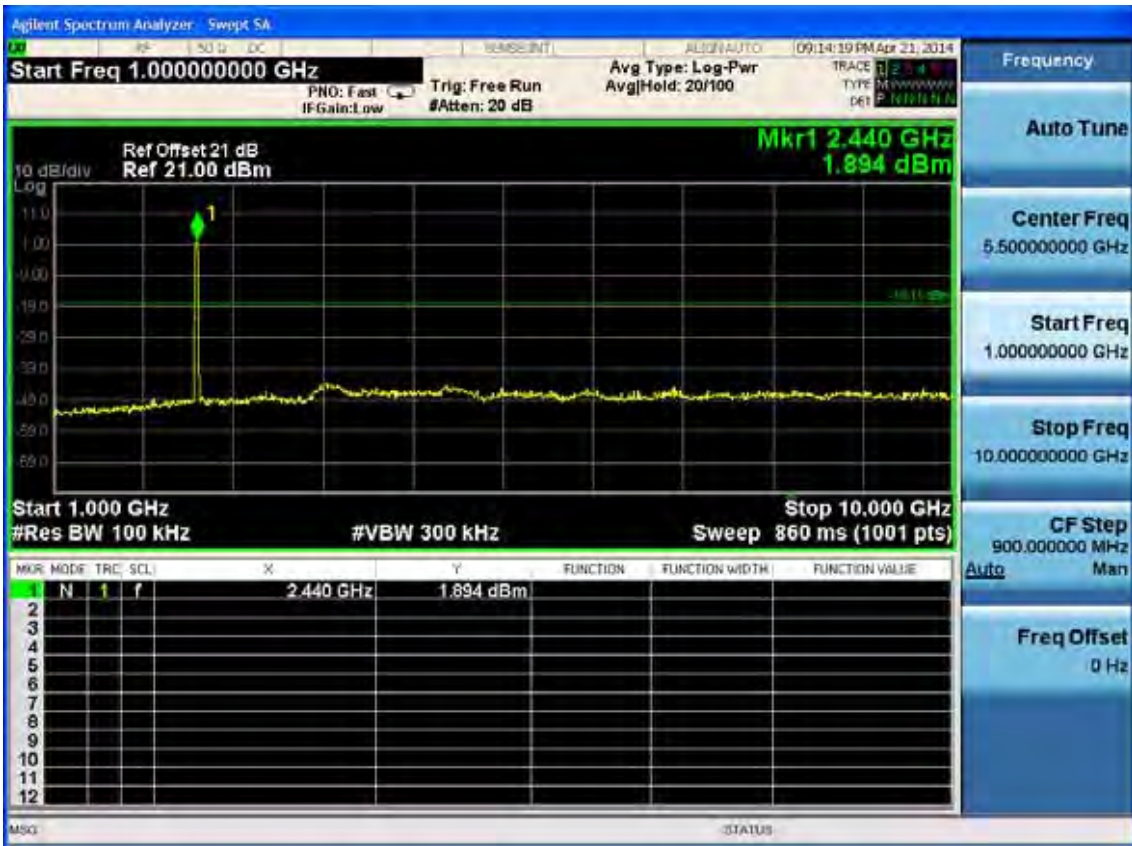

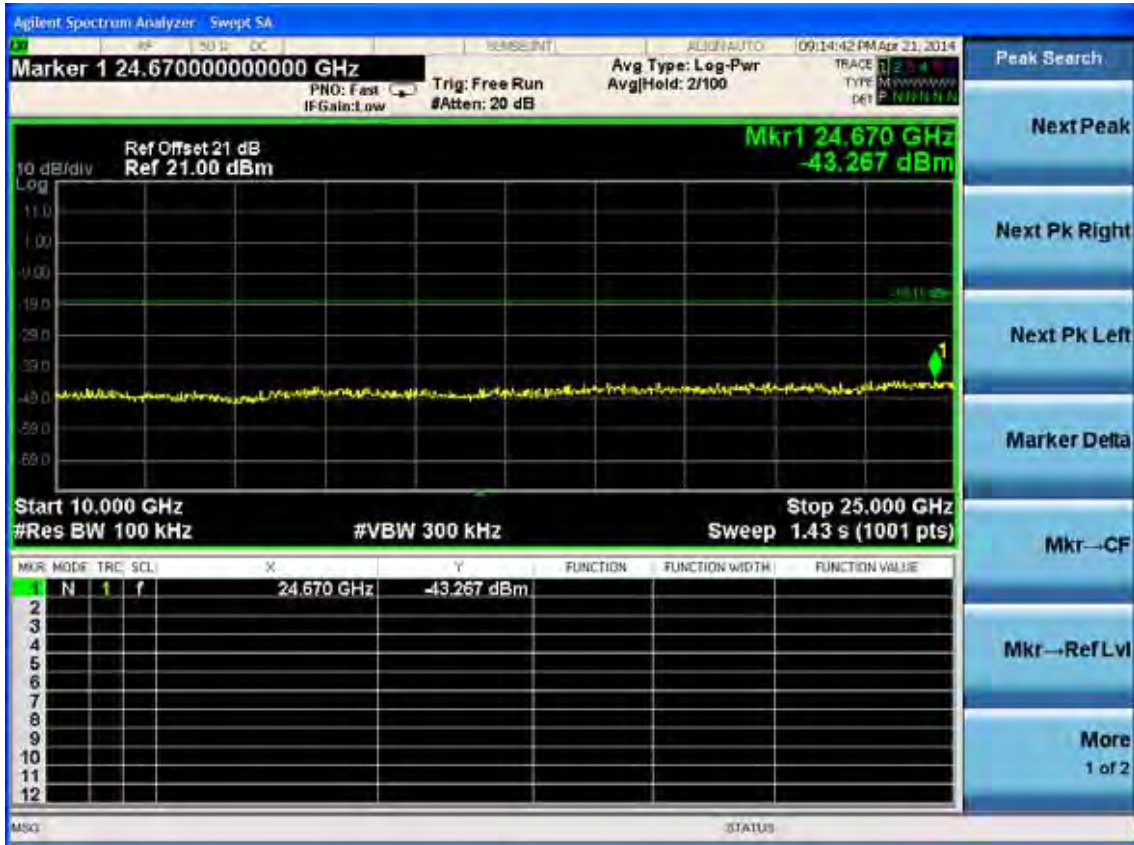

Test CH11: 2462MHz

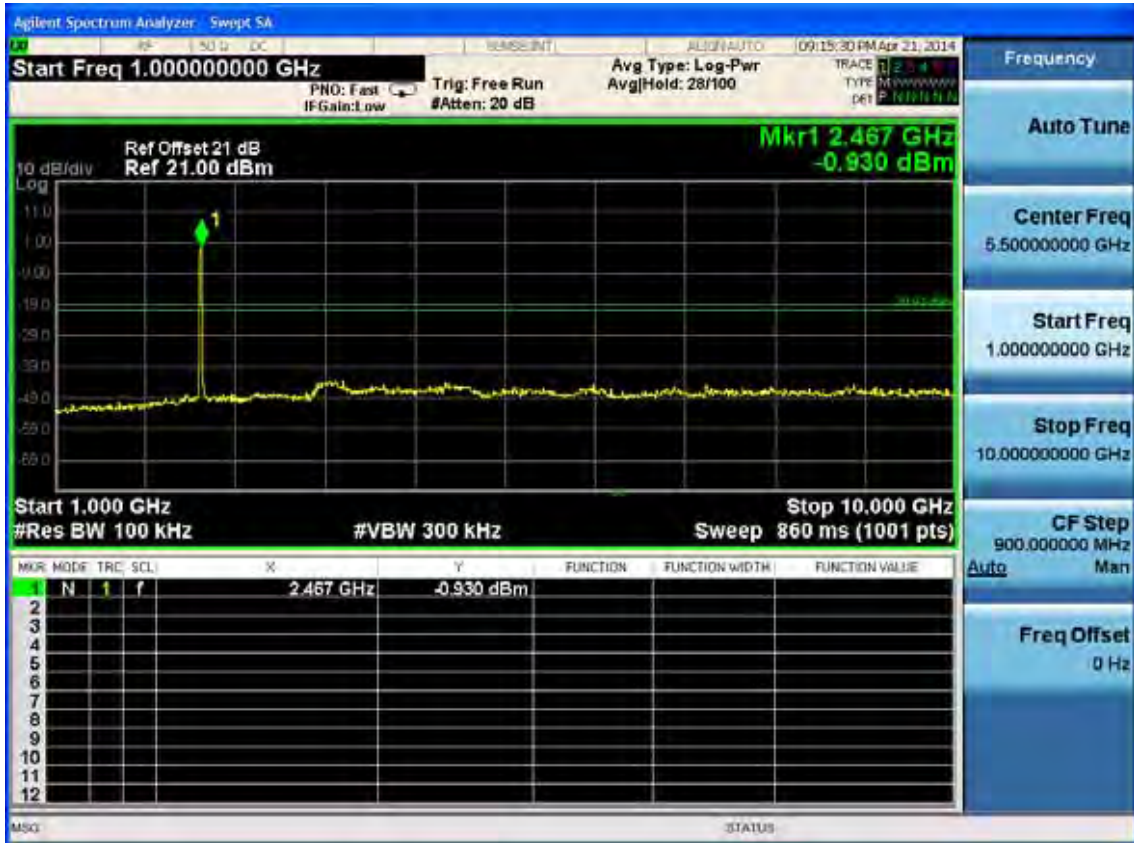

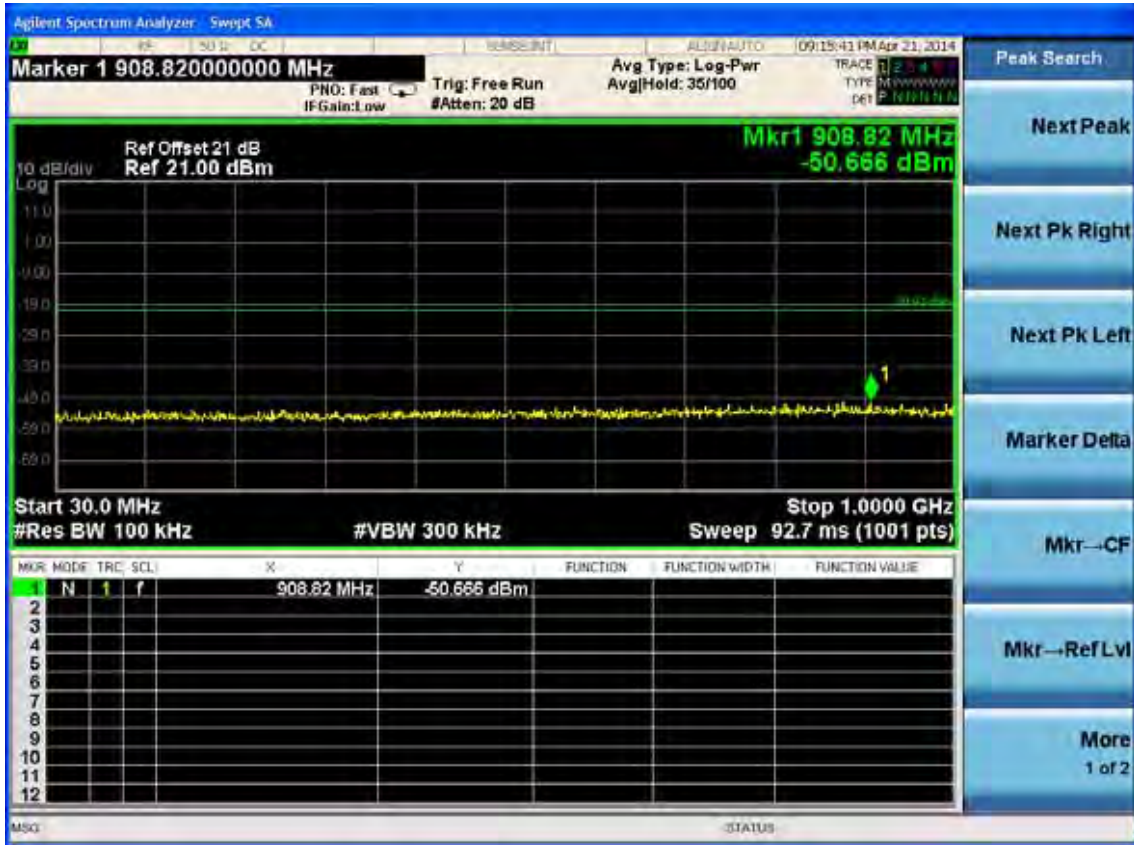



Test Mode: IEEE 802.11n HT40
Test CH1: 2422MHz

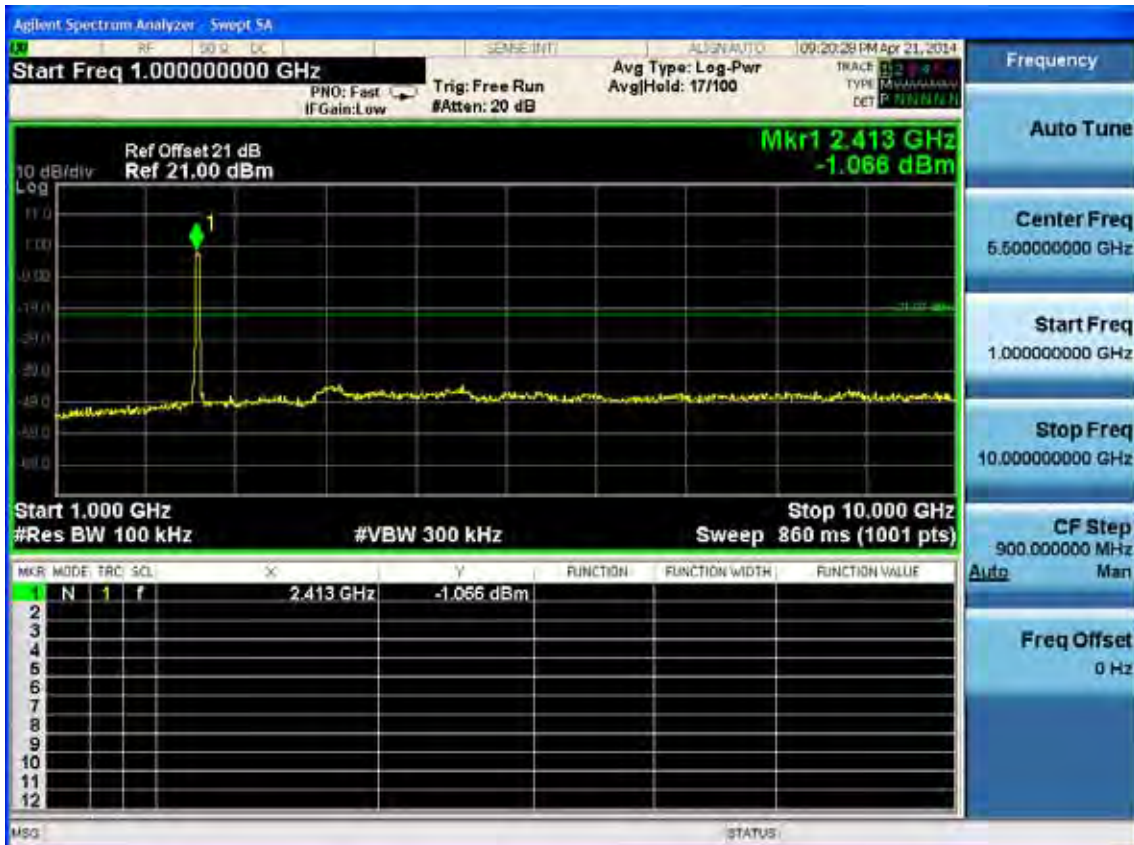

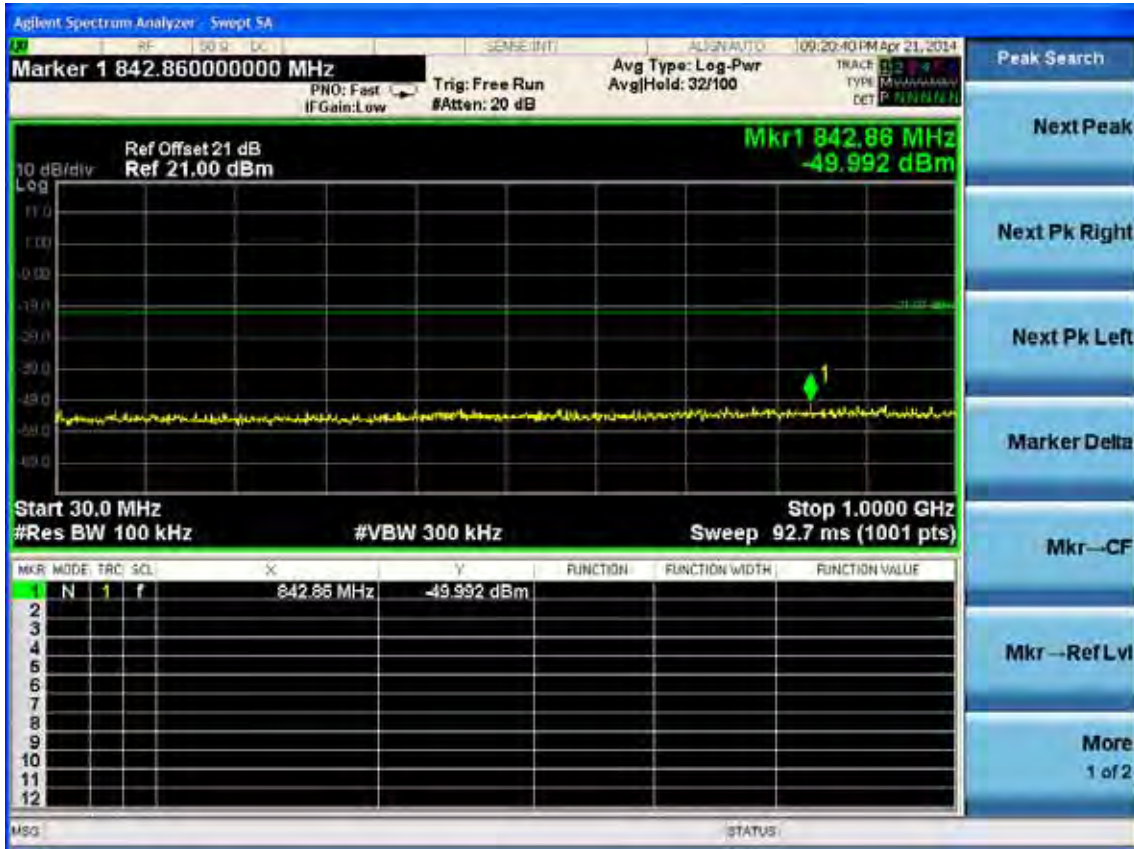



Test CH4: 2437MHz

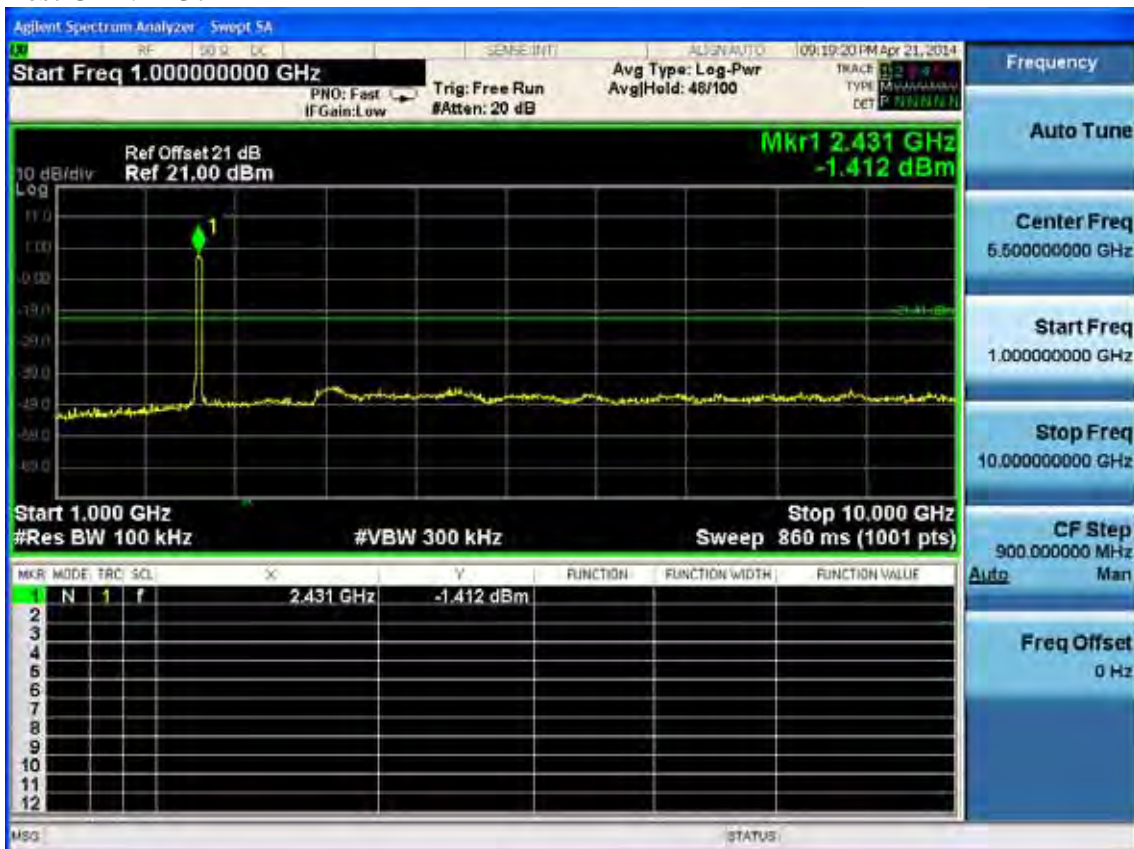

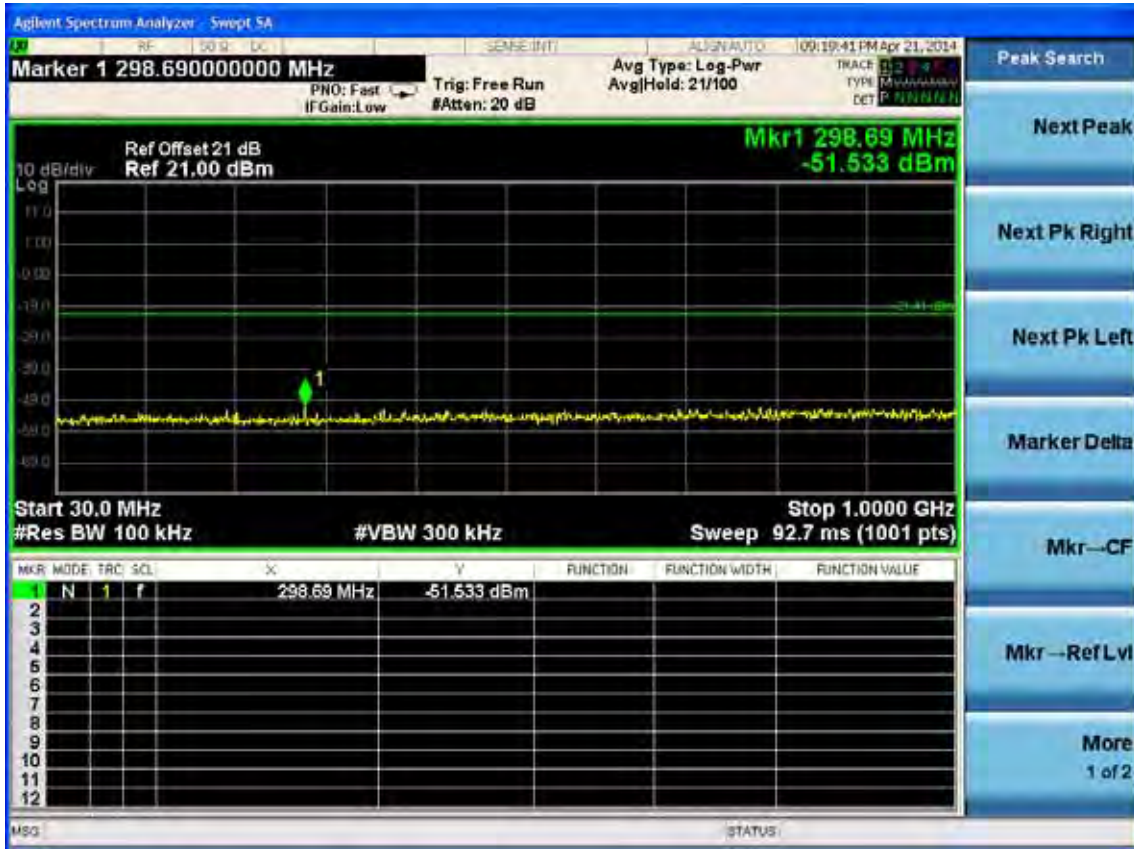

Test CH7: 2452MHz

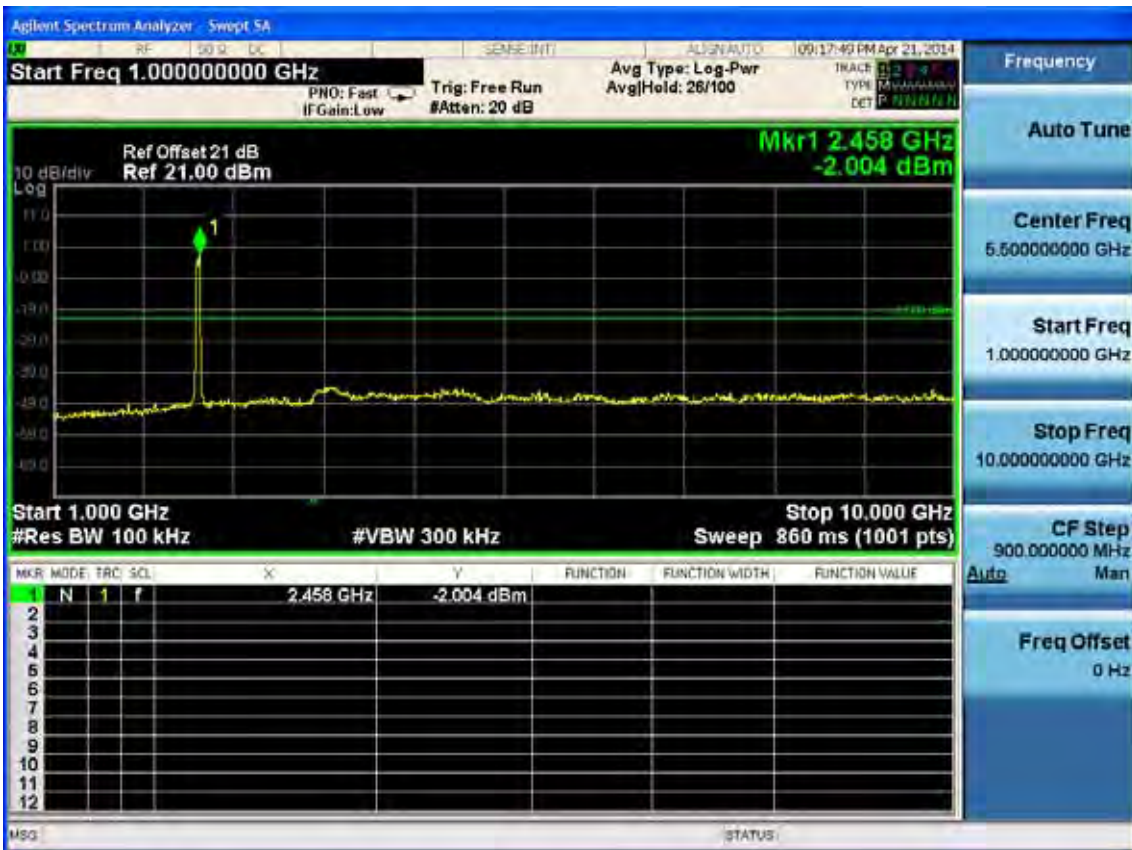

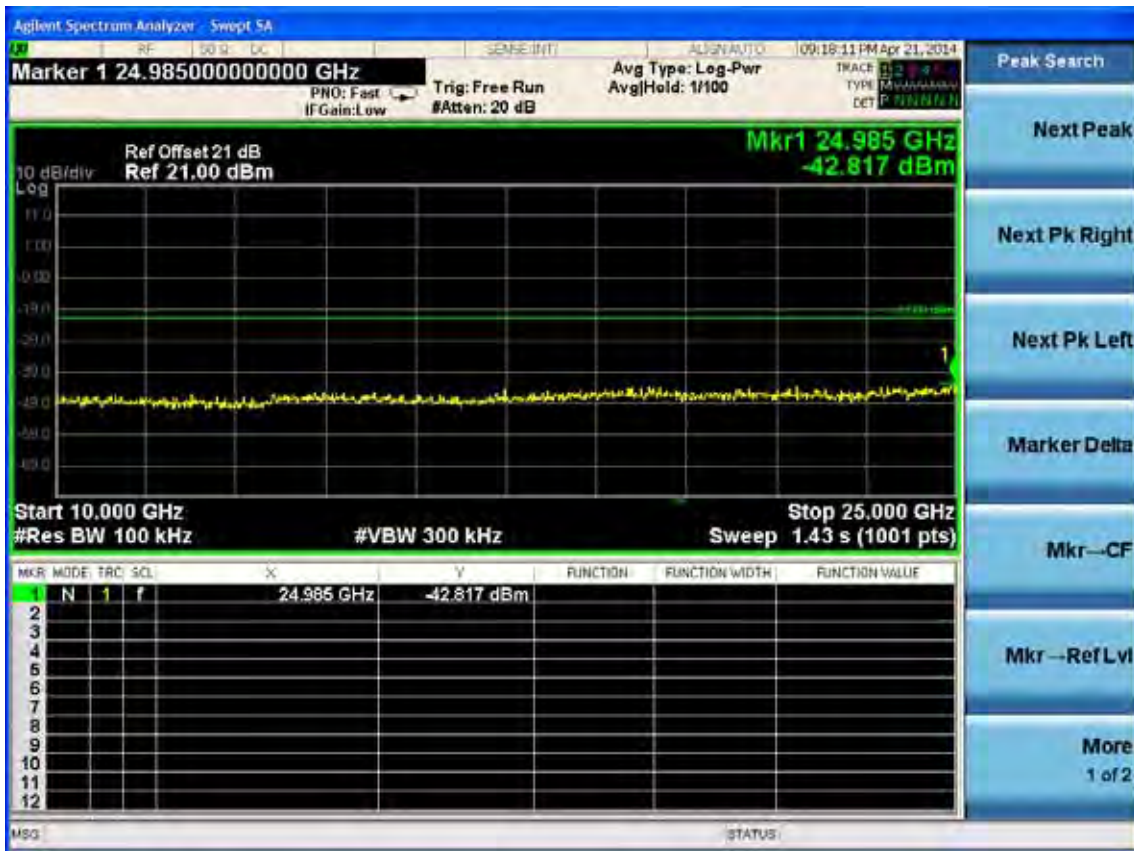
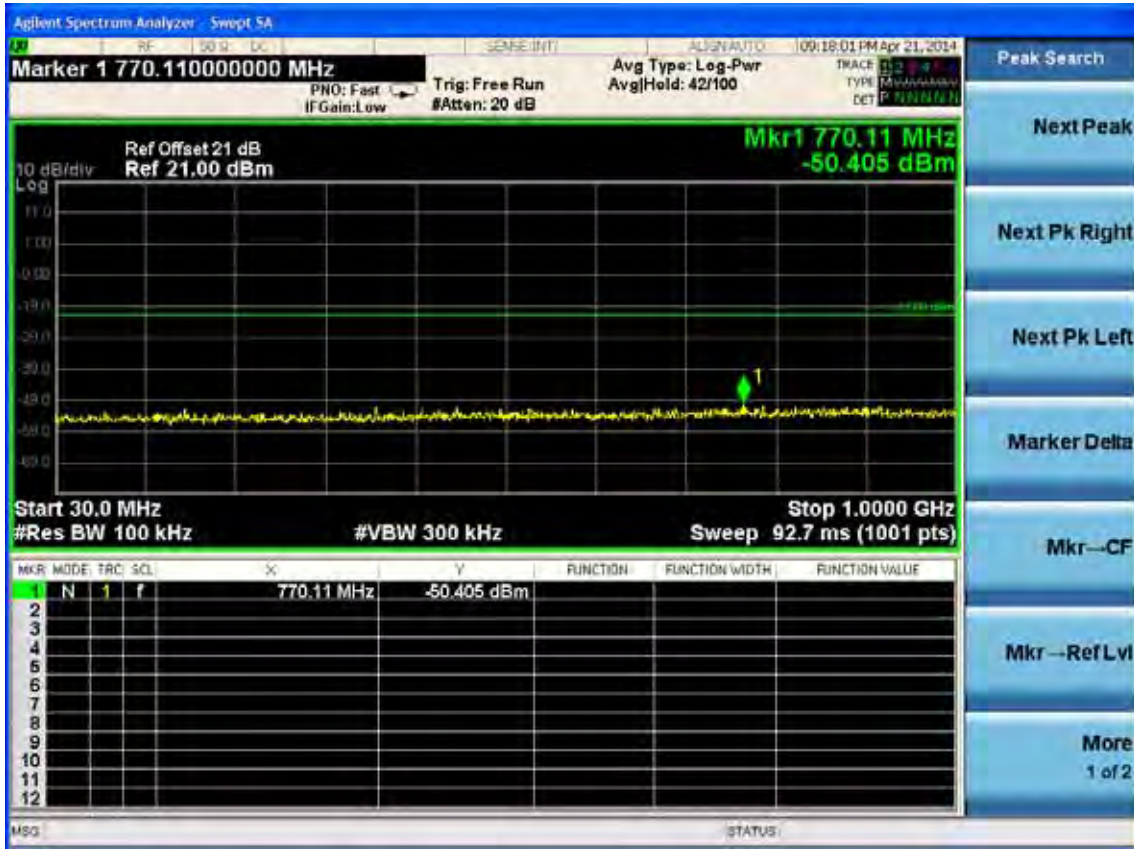

6. BAND EDGE COMPLIANCE TEST

6.1. Test Equipment

Item	Equipment	Manufacturer	Model No.	Serial No.	Last Cal.	Cal. Interval
1.	Spectrum	Agilent	N9030A	MY51380221	Oct.31, 13	1 Year
2.	Attenuator (20dB)	Agilent	8491B	MY39262165	Apr. 28,14	1 Year
3.	RF Cable	Hubersuhner	SUCOFLEX102	28620/2	Apr. 28,14	1 Year

6.2. Limit

All the lower and upper band-edges emissions appearing within 2310MHz to 2390MHz and 2483.5MHz to 2500MHz restricted frequency bands shall not exceed the limits shown in 15.209, all the other emissions outside operation frequency band 2400MHz to 2483.5MHz shall be at least 20dB below the fundamental emissions, or comply with 15.209 limits.

6.3. Test Produce

1. The EUT is placed on a turntable, which is 0.8m above the ground plane and worked at highest radiated power.
2. The turntable was rotated for 360 degrees to determine the position of maximum emission level.
3. EUT is set 3m away from the receiving antenna, which is varied from 1m to 4m to find out the highest emission.
4. Set the spectrum analyzer in the following setting in order to capture the lower and upper band-edges of the emission:
 - (a) PEAK: RBW=1MHz; VBW=3MHz ;Sweep=AUTO
 - (b) AVERAGE: RBW=1MHz ;VBW=10Hz ; Sweep=AUTO

6.4. Test Results

Pass (The testing data was attached in the next pages.)

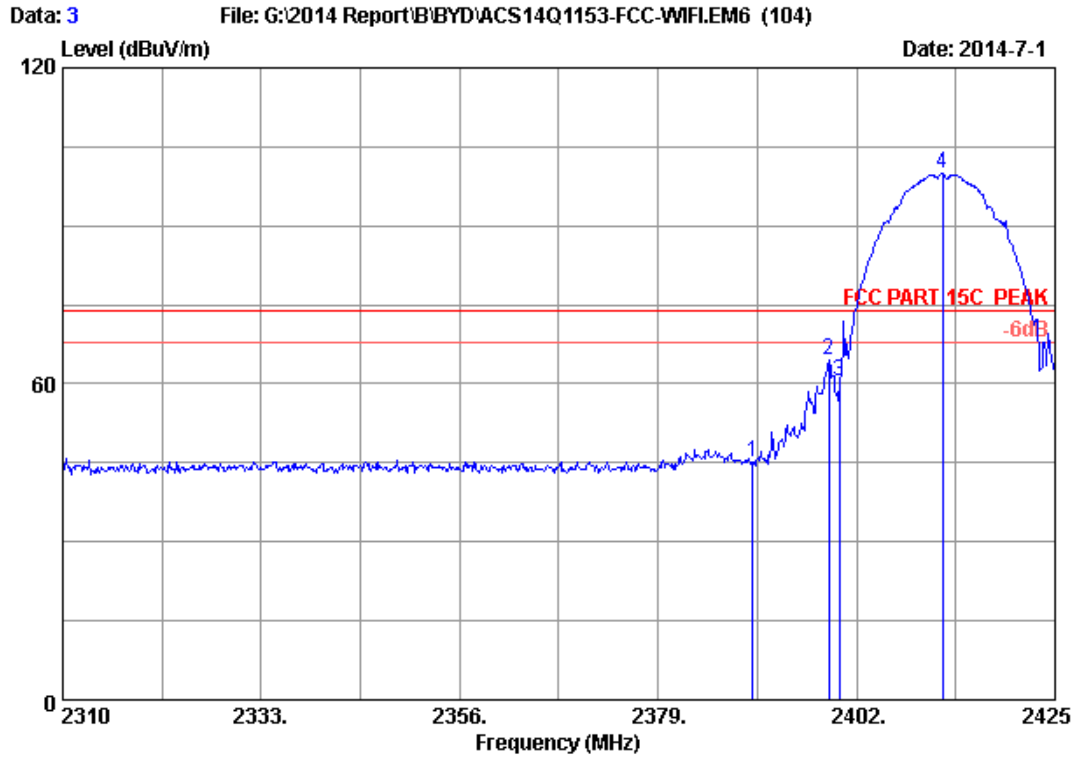

Site no. : 3m Chamber Data no. : 3
 Dis. / Ant. : 3m 2013 3115 (4580) Ant. pol. : HORIZONTAL
 Limit : FCC PART 15C PEAK
 Env. / Ins. : 24°C/56% Engineer : Kevin_Hu
 EUT : Tablet PC
 Power Rating : DC 5V From Adapter Input AC 120V/60Hz
 Test Mode : IEEE802.11b 2412MHz Tx Mode
 M/N : WT7-C

No.	Freq. (MHz)	Ant. Factor (dB/m)	Cable Loss (dB)	AMP factor (dB)	Reading (dBuV)	Emission Level (dBuV/m)	Limits (dBuV/m)	Margin (dB)	Remark
1	2390.000	28.16	5.78	35.70	46.87	45.11	74.00	28.89	Peak
2	2398.780	28.18	5.80	35.70	66.35	64.63	74.00	9.37	Peak
3	2400.000	28.18	5.80	35.70	62.33	60.61	74.00	13.39	Peak
4	2412.005	28.21	5.81	35.70	101.78	100.10	74.00	-26.10	Peak

Remarks: 1. Emission Level= Antenna Factor + Cable Loss + Reading - Amp Factor
 2. The emission levels that are 20dB below the official limit are not reported.

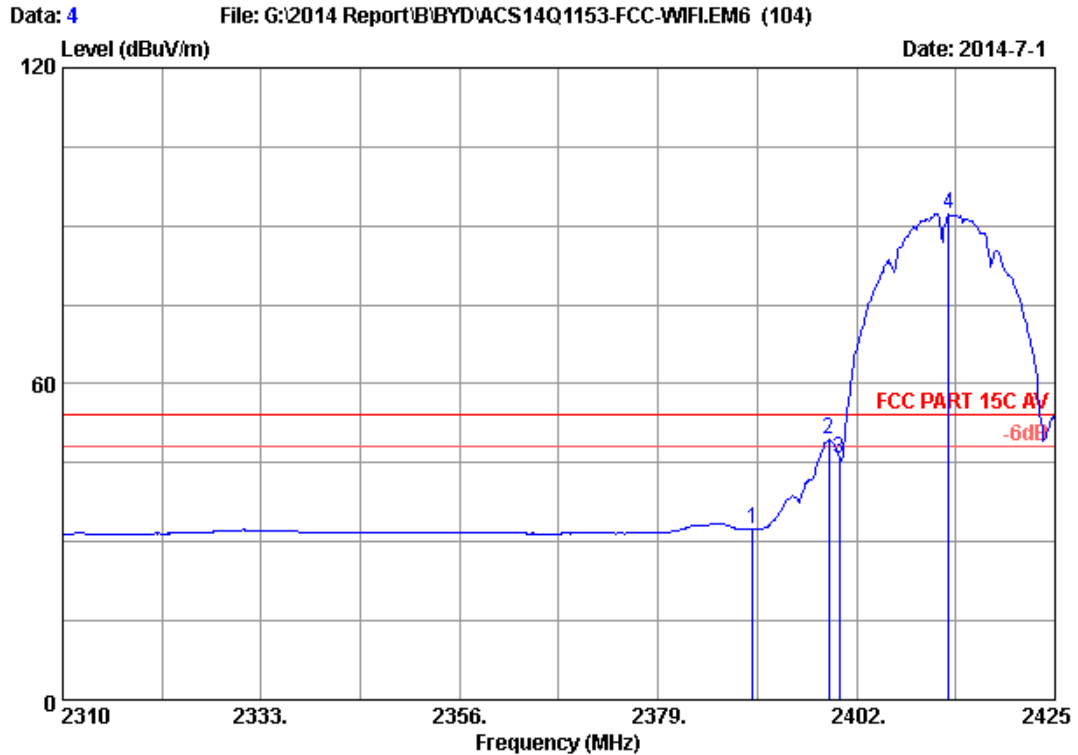

Site no. : 3m Chamber Data no. : 4
 Dis. / Ant. : 3m 2013 3115 (4580) Ant. pol. : HORIZONTAL
 Limit : FCC PART 15C AV
 Env. / Ins. : 24°C/56% Engineer : Kevin_Hu
 EUT : Tablet PC
 Power Rating : DC 5V From Adapter Input AC 120V/60Hz
 Test Mode : IEEE802.11b 2412MHz Tx Mode
 M/N : WT7-C

No.	Freq. (MHz)	Ant. Factor (dB/m)	Cable Loss (dB)	AMP factor (dB)	Reading (dBuV)	Emission Level (dBuV/m)	Limits (dBuV/m)	Margin (dB)	Remark
1	2390.000	28.16	5.78	35.70	34.17	32.41	54.00	21.59	Average
2	2398.780	28.18	5.80	35.70	51.03	49.31	54.00	4.69	Average
3	2400.000	28.18	5.80	35.70	47.51	45.79	54.00	8.21	Average
4	2412.695	28.21	5.82	35.70	93.93	92.26	54.00	-38.26	Average

Remarks: 1. Emission Level= Antenna Factor + Cable Loss + Reading - Amp Factor
 2. The emission levels that are 20dB below the official limit are not reported.

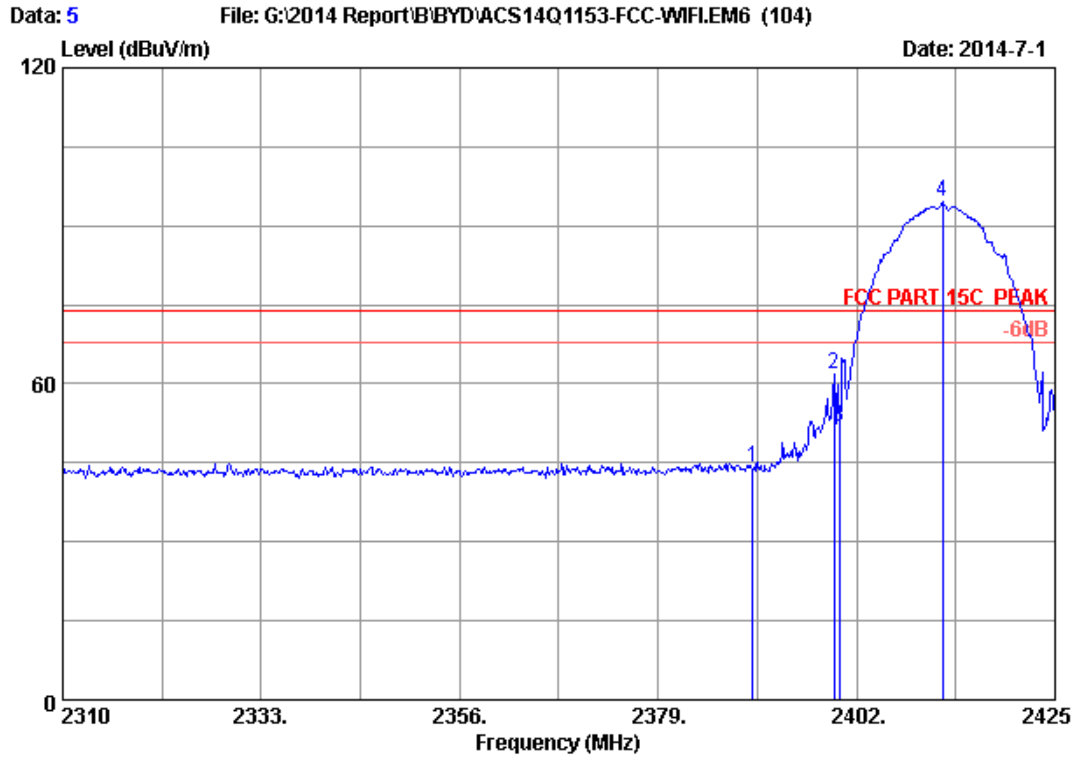

Site no. : 3m Chamber Data no. : 5
 Dis. / Ant. : 3m 2013 3115 (4580) Ant. pol. : VERTICAL
 Limit : FCC PART 15C PEAK
 Env. / Ins. : 24°C/56% Engineer : Kevin_Hu
 EUT : Tablet PC
 Power Rating : DC 5V From Adapter Input AC 120V/60Hz
 Test Mode : IEEE802.11b 2412MHz Tx Mode
 M/N : WT7-C

No.	Freq. (MHz)	Ant. Factor (dB/m)	Cable Loss (dB)	AMP factor (dB)	Reading (dBuV)	Emission Level (dBuV/m)	Limits (dBuV/m)	Margin (dB)	Remark
1	2390.000	28.16	5.78	35.70	45.78	44.02	74.00	29.98	Peak
2	2399.355	28.18	5.80	35.70	63.51	61.79	74.00	12.21	Peak
3	2400.000	28.18	5.80	35.70	53.62	51.90	74.00	22.10	Peak
4	2412.005	28.21	5.81	35.70	96.15	94.47	74.00	-20.47	Peak

Remarks: 1. Emission Level= Antenna Factor + Cable Loss + Reading - Amp Factor
 2. The emission levels that are 20dB below the official limit are not reported.

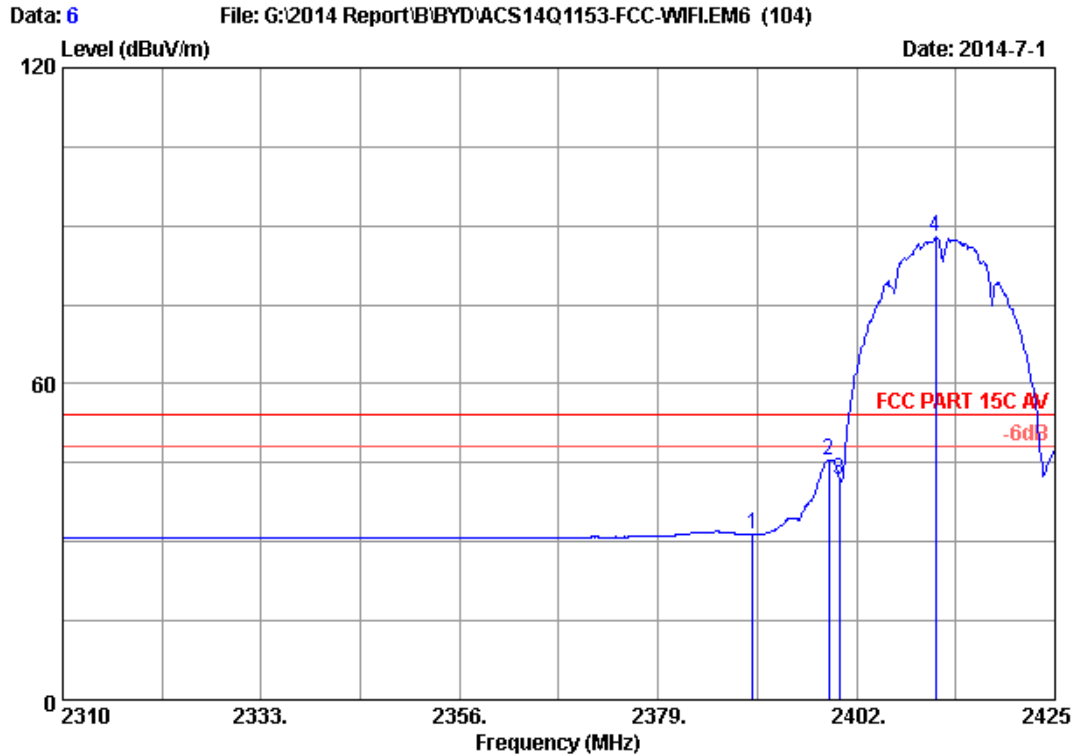

Site no. : 3m Chamber Data no. : 6
 Dis. / Ant. : 3m 2013 3115 (4580) Ant. pol. : VERTICAL
 Limit : FCC PART 15C AV
 Env. / Ins. : 24°C/56% Engineer : Kevin_Hu
 EUT : Tablet PC
 Power Rating : DC 5V From Adapter Input AC 120V/60Hz
 Test Mode : IEEE802.11b 2412MHz Tx Mode
 M/N : WT7-C

No.	Freq. (MHz)	Ant. Factor (dB/m)	Cable Loss (dB)	AMP factor (dB)	Reading (dBuV)	Emission Level (dBuV/m)	Limits (dBuV/m)	Margin (dB)	Remark
1	2390.000	28.16	5.78	35.70	33.26	31.50	54.00	22.50	Average
2	2398.780	28.18	5.80	35.70	47.25	45.53	54.00	8.47	Average
3	2400.000	28.18	5.80	35.70	43.50	41.78	54.00	12.22	Average
4	2411.200	28.20	5.81	35.70	89.49	87.80	54.00	-33.80	Average

Remarks: 1. Emission Level= Antenna Factor + Cable Loss + Reading - Amp Factor
 2. The emission levels that are 20dB below the official limit are not reported.

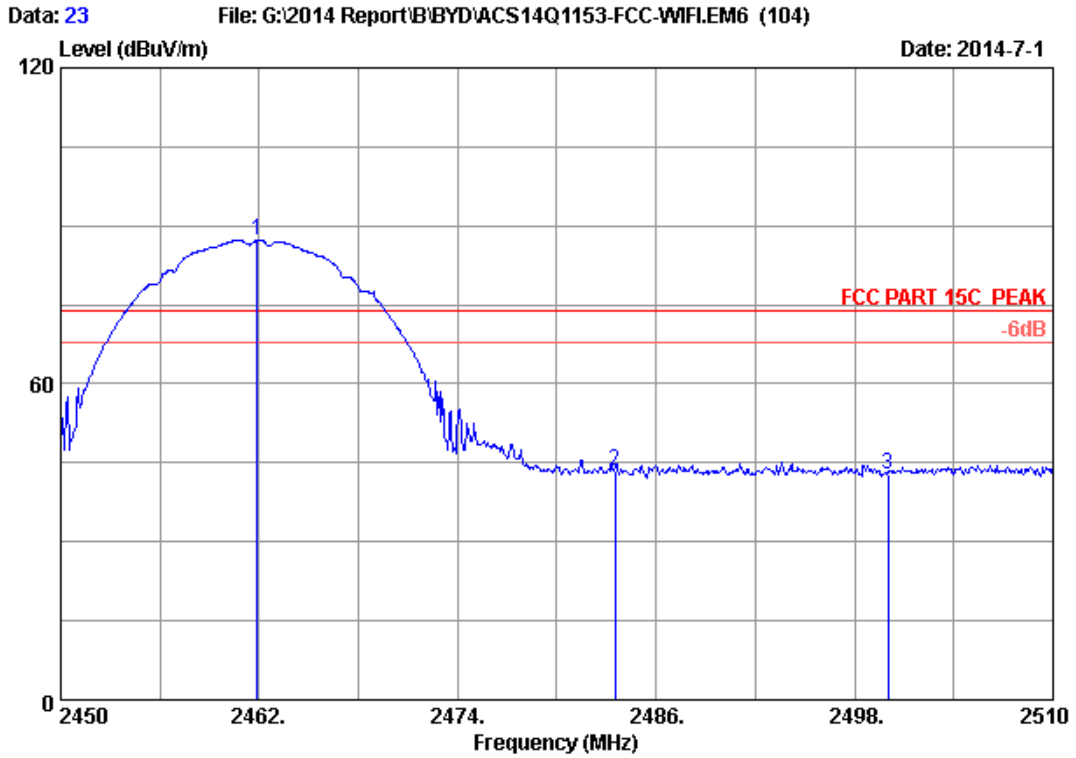

Site no. : 3m Chamber Data no. : 23
 Dis. / Ant. : 3m 2013 3115 (4580) Ant. pol. : VERTICAL
 Limit : FCC PART 15C PEAK
 Env. / Ins. : 24°C/56% Engineer : Kevin_Hu
 EUT : Tablet PC
 Power Rating : DC 5V From Adapter Input AC 120V/60Hz
 Test Mode : IEEE802.11b 2462MHz Tx Mode
 M/N : WT7-C

No.	Freq. (MHz)	Ant. Factor (dB/m)	Cable Loss (dB)	AMP factor (dB)	Reading (dBuV)	Emission Level (dBuV/m)	Limits (dBuV/m)	Margin (dB)	Remark
1	2461.880	28.32	5.89	35.70	88.89	87.40	74.00	-13.40	Peak
2	2483.500	28.36	5.92	35.70	44.98	43.56	74.00	30.44	Peak
3	2500.000	28.40	5.94	35.70	44.10	42.74	74.00	31.26	Peak

Remarks: 1. Emission Level= Antenna Factor + Cable Loss + Reading
 -Amp Factor
 2. The emission levels that are 20dB below the official limit are not reported.

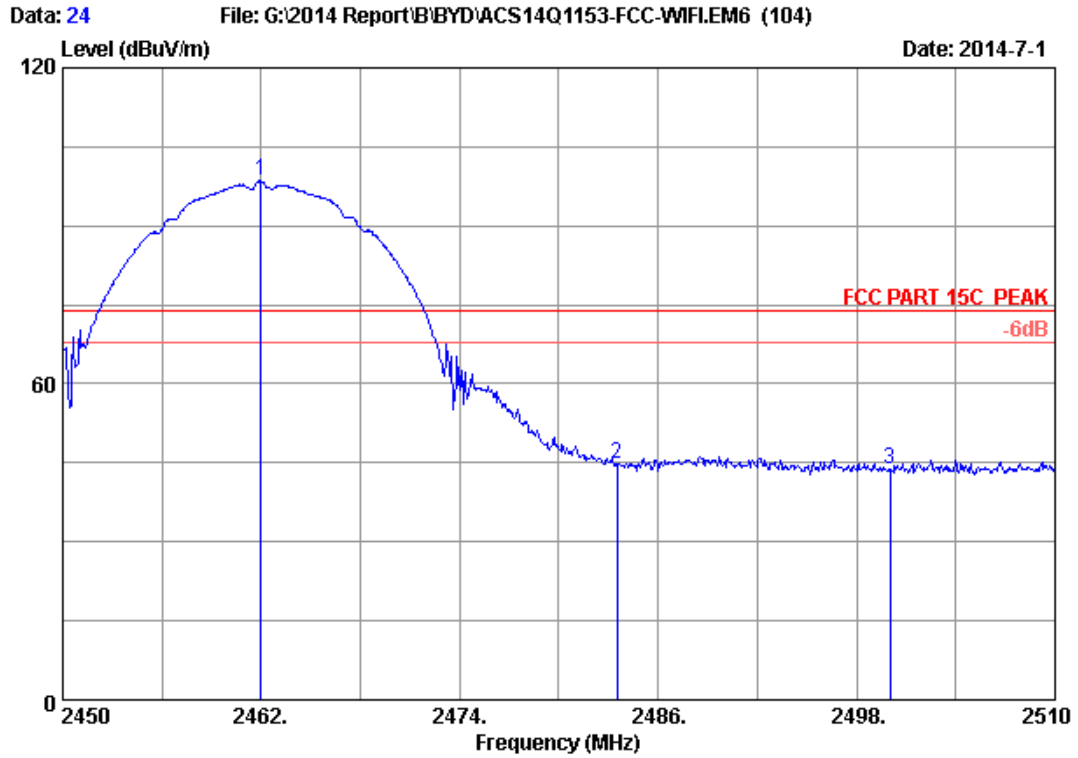

Site no. : 3m Chamber Data no. : 24
 Dis. / Ant. : 3m 2013 3115 (4580) Ant. pol. : HORIZONTAL
 Limit : FCC PART 15C PEAK
 Env. / Ins. : 24°C/56% Engineer : Kevin_Hu
 EUT : Tablet PC
 Power Rating : DC 5V From Adapter Input AC 120V/60Hz
 Test Mode : IEEE802.11b 2462MHz Tx Mode
 M/N : WT7-C

No.	Freq. (MHz)	Ant. Factor (dB/m)	Cable Loss (dB)	AMP factor (dB)	Reading (dBuV)	Emission Level (dBuV/m)	Limits (dBuV/m)	Margin (dB)	Remark
1	2462.000	28.32	5.89	35.70	100.00	98.51	74.00	-24.51	Peak
2	2483.500	28.36	5.92	35.70	46.05	44.63	74.00	29.37	Peak
3	2500.000	28.40	5.94	35.70	45.12	43.76	74.00	30.24	Peak

Remarks: 1. Emission Level= Antenna Factor + Cable Loss + Reading - Amp Factor
 2. The emission levels that are 20dB below the official limit are not reported.

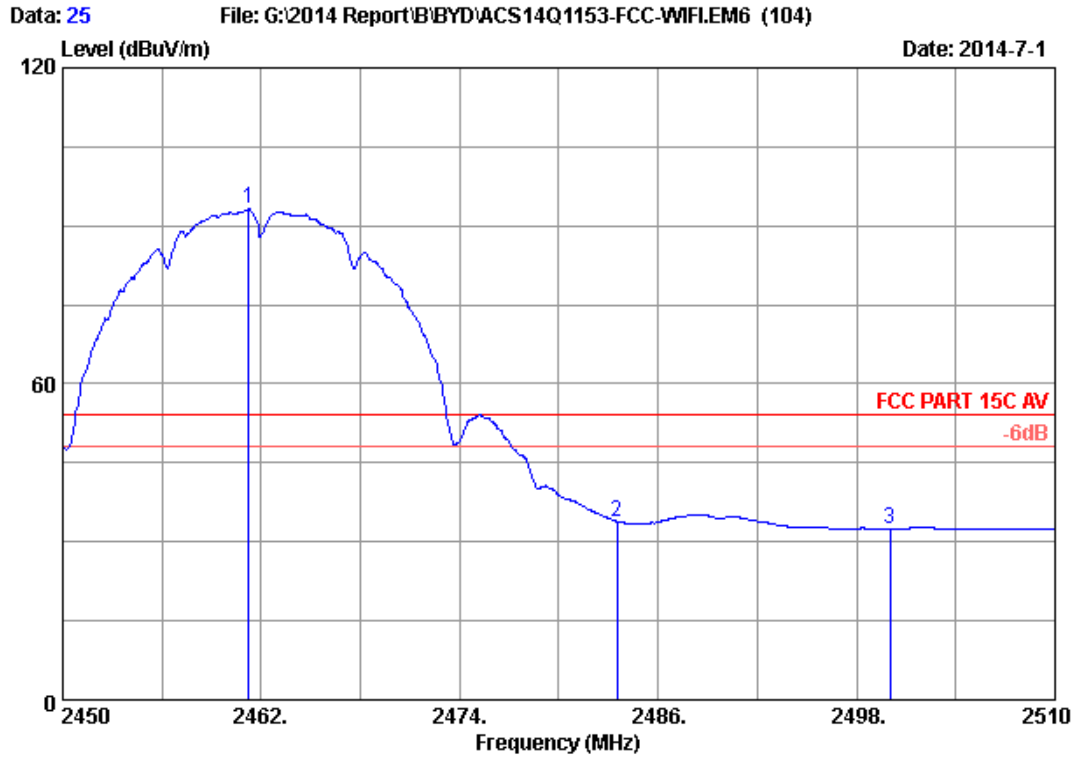

Site no. : 3m Chamber Data no. : 25
 Dis. / Ant. : 3m 2013 3115 (4580) Ant. pol. : HORIZONTAL
 Limit : FCC PART 15C AV
 Env. / Ins. : 24°C/56% Engineer : Kevin_Hu
 EUT : Tablet PC
 Power Rating : DC 5V From Adapter Input AC 120V/60Hz
 Test Mode : IEEE802.11b 2462MHz Tx Mode
 M/N : WT7-C

No.	Freq. (MHz)	Ant. Factor (dB/m)	Cable Loss (dB)	AMP factor (dB)	Reading (dBuV)	Emission Level (dBuV/m)	Limits (dBuV/m)	Margin (dB)	Remark
1	2461.220	28.31	5.89	35.70	94.63	93.13	54.00	-39.13	Average
2	2483.500	28.36	5.92	35.70	35.32	33.90	54.00	20.10	Average
3	2500.000	28.40	5.94	35.70	33.90	32.54	54.00	21.46	Average

Remarks: 1. Emission Level= Antenna Factor + Cable Loss + Reading - Amp Factor
 2. The emission levels that are 20dB below the official limit are not reported.

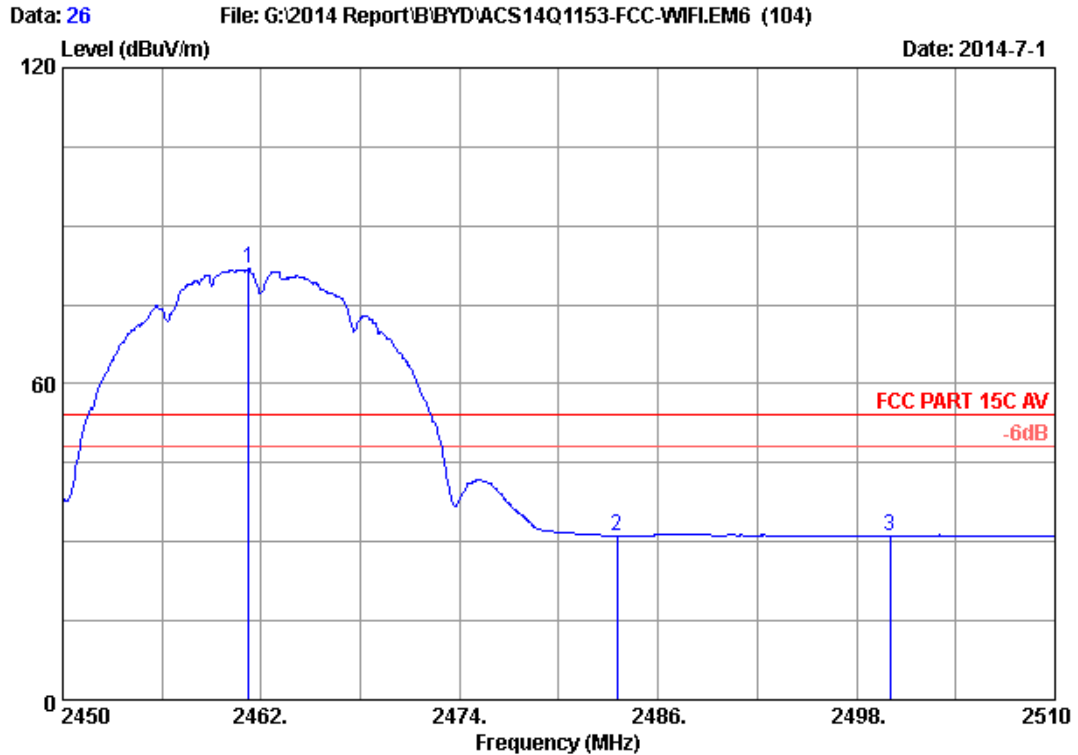

Site no. : 3m Chamber Data no. : 26
 Dis. / Ant. : 3m 2013 3115 (4580) Ant. pol. : VERTICAL
 Limit : FCC PART 15C AV
 Env. / Ins. : 24°C/56% Engineer : Kevin_Hu
 EUT : Tablet PC
 Power Rating : DC 5V From Adapter Input AC 120V/60Hz
 Test Mode : IEEE802.11b 2462MHz Tx Mode
 M/N : WT7-C

No.	Freq. (MHz)	Ant. Factor (dB/m)	Cable Loss (dB)	AMP factor (dB)	Reading (dBuV)	Emission Level (dBuV/m)	Limits (dBuV/m)	Margin (dB)	Remark
1	2461.220	28.31	5.89	35.70	83.31	81.81	54.00	-27.81	Average
2	2483.500	28.36	5.92	35.70	32.64	31.22	54.00	22.78	Average
3	2500.000	28.40	5.94	35.70	32.49	31.13	54.00	22.87	Average

Remarks: 1. Emission Level= Antenna Factor + Cable Loss + Reading - Amp Factor
 2. The emission levels that are 20dB below the official limit are not reported.

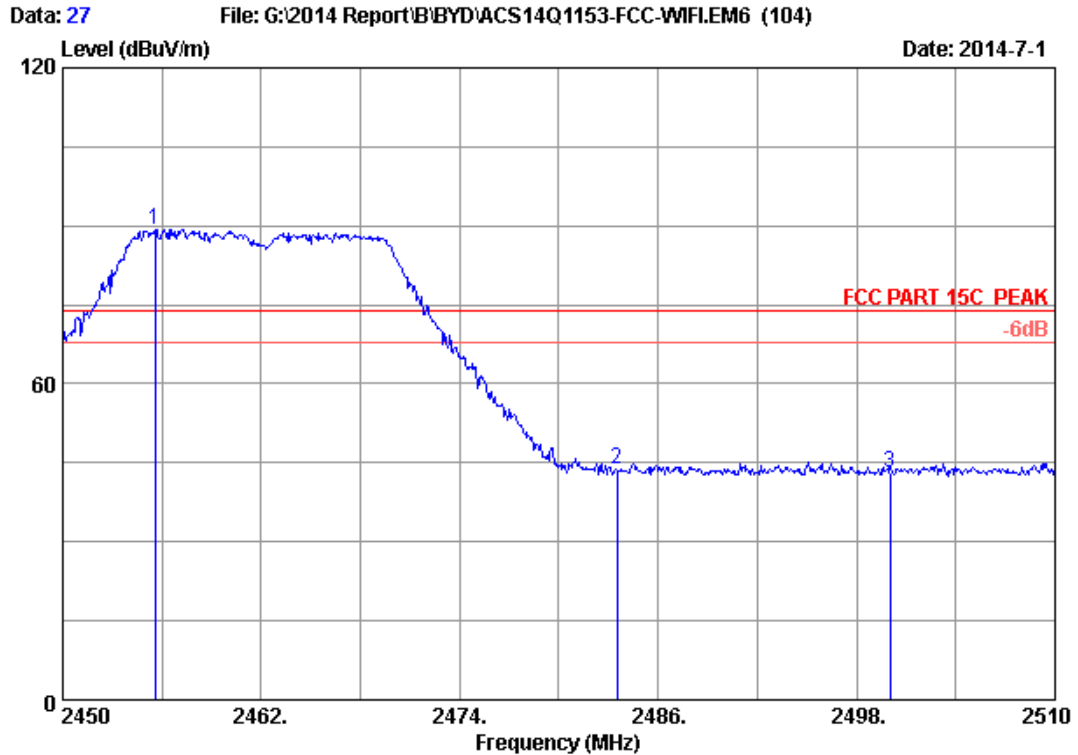

Site no. : 3m Chamber Data no. : 27
 Dis. / Ant. : 3m 2013 3115 (4580) Ant. pol. : VERTICAL
 Limit : FCC PART 15C PEAK
 Env. / Ins. : 24°C/56% Engineer : Kevin_Hu
 EUT : Tablet PC
 Power Rating : DC 5V From Adapter Input AC 120V/60Hz
 Test Mode : IEEE802.11g 2462MHz Tx Mode
 M/N : WT7-C

No.	Freq. (MHz)	Ant. Factor (dB/m)	Cable Loss (dB)	AMP factor (dB)	Reading (dBuV)	Emission Level (dBuV/m)	Limits (dBuV/m)	Margin (dB)	Remark
1	2455.580	28.30	5.88	35.70	90.78	89.26	74.00	-15.26	Peak
2	2483.500	28.36	5.92	35.70	45.16	43.74	74.00	30.26	Peak
3	2500.000	28.40	5.94	35.70	44.39	43.03	74.00	30.97	Peak

Remarks: 1. Emission Level= Antenna Factor + Cable Loss + Reading
 -Amp Factor
 2. The emission levels that are 20dB below the official
 limit are not reported.

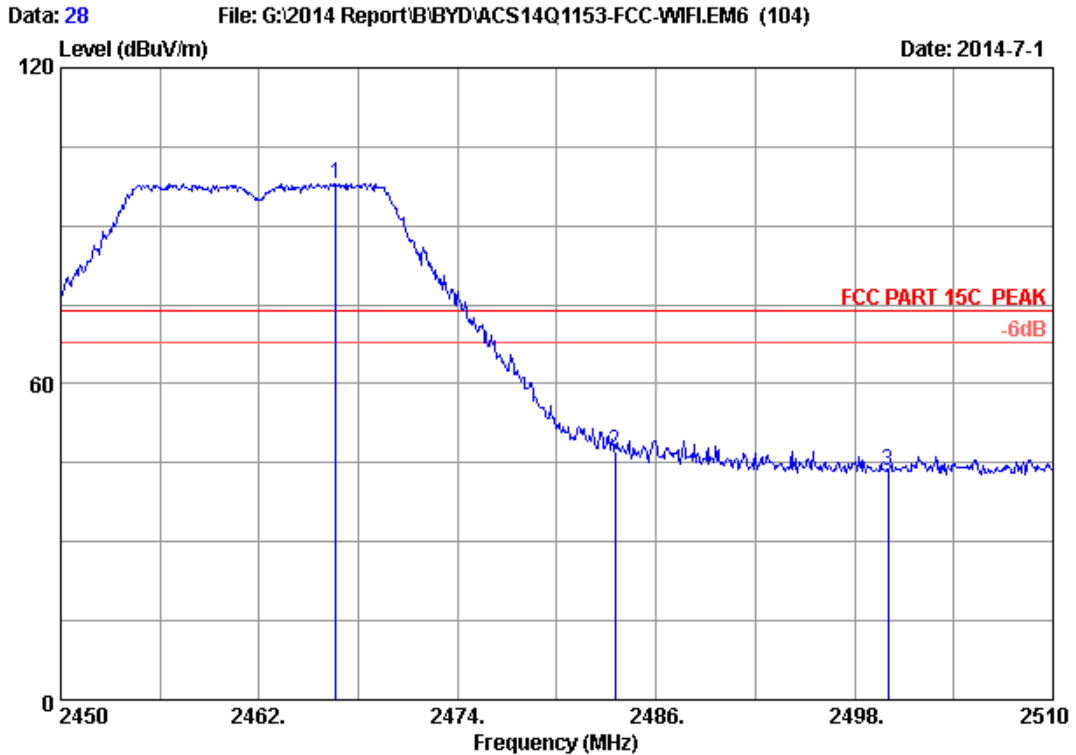

Site no. : 3m Chamber Data no. : 28
 Dis. / Ant. : 3m 2013 3115 (4580) Ant. pol. : HORIZONTAL
 Limit : FCC PART 15C PEAK
 Env. / Ins. : 24°C/56% Engineer : Kevin_Hu
 EUT : Tablet PC
 Power Rating : DC 5V From Adapter Input AC 120V/60Hz
 Test Mode : IEEE802.11g 2462MHz Tx Mode
 M/N : WT7-C

No.	Freq. (MHz)	Ant. Factor (dB/m)	Cable Loss (dB)	AMP factor (dB)	Reading (dBuV)	Emission Level (dBuV/m)	Limits (dBuV/m)	Margin (dB)	Remark
1	2466.620	28.33	5.89	35.70	99.56	98.08	74.00	-24.08	Peak
2	2483.500	28.36	5.92	35.70	48.50	47.08	74.00	26.92	Peak
3	2500.000	28.40	5.94	35.70	44.74	43.38	74.00	30.62	Peak

Remarks: 1. Emission Level= Antenna Factor + Cable Loss + Reading - Amp Factor
 2. The emission levels that are 20dB below the official limit are not reported.

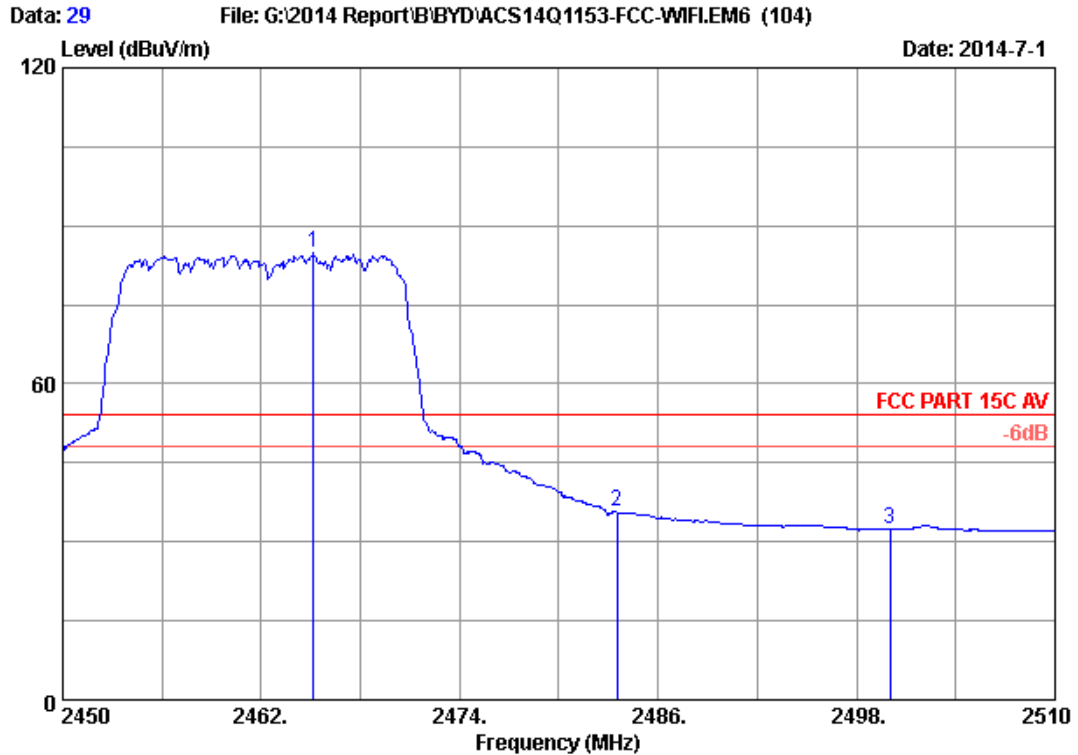

Site no. : 3m Chamber Data no. : 29
 Dis. / Ant. : 3m 2013 3115 (4580) Ant. pol. : HORIZONTAL
 Limit : FCC PART 15C AV
 Env. / Ins. : 24°C/56% Engineer : Kevin_Hu
 EUT : Tablet PC
 Power Rating : DC 5V From Adapter Input AC 120V/60Hz
 Test Mode : IEEE802.11g 2462MHz Tx Mode
 M/N : WT7-C

No.	Freq. (MHz)	Ant. Factor (dB/m)	Cable Loss (dB)	AMP factor (dB)	Reading (dBuV)	Emission Level (dBuV/m)	Limits (dBuV/m)	Margin (dB)	Remark
1	2465.180	28.32	5.89	35.70	86.44	84.95	54.00	-30.95	Average
2	2483.500	28.36	5.92	35.70	37.10	35.68	54.00	18.32	Average
3	2500.000	28.40	5.94	35.70	33.78	32.42	54.00	21.58	Average

Remarks: 1. Emission Level= Antenna Factor + Cable Loss + Reading - Amp Factor
 2. The emission levels that are 20dB below the official limit are not reported.

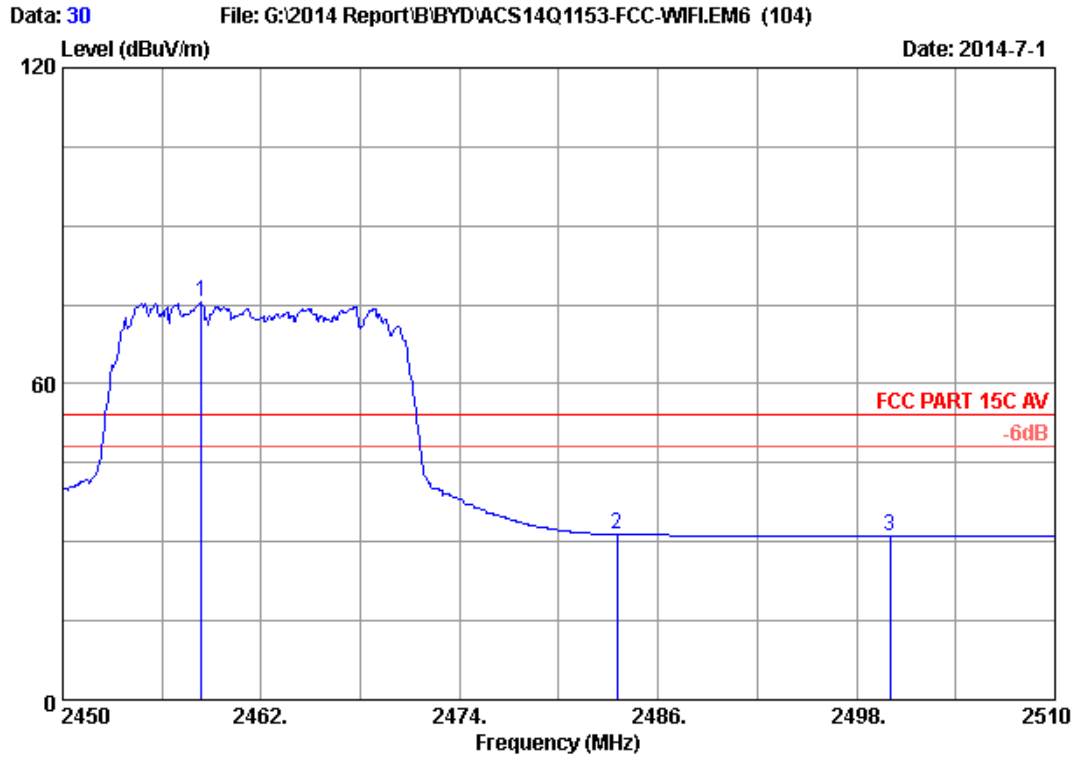

Site no. : 3m Chamber Data no. : 30
 Dis. / Ant. : 3m 2013 3115 (4580) Ant. pol. : VERTICAL
 Limit : FCC PART 15C AV
 Env. / Ins. : 24°C/56% Engineer : Kevin_Hu
 EUT : Tablet PC
 Power Rating : DC 5V From Adapter Input AC 120V/60Hz
 Test Mode : IEEE802.11g 2462MHz Tx Mode
 M/N : WT7-C

No.	Freq. (MHz)	Ant. Factor (dB/m)	Cable Loss (dB)	AMP factor (dB)	Reading (dBuV)	Emission Level (dBuV/m)	Limits (dBuV/m)	Margin (dB)	Remark
1	2458.400	28.31	5.88	35.70	76.90	75.39	54.00	-21.39	Average
2	2483.500	28.36	5.92	35.70	32.84	31.42	54.00	22.58	Average
3	2500.000	28.40	5.94	35.70	32.50	31.14	54.00	22.86	Average

Remarks: 1. Emission Level= Antenna Factor + Cable Loss + Reading - Amp Factor
 2. The emission levels that are 20dB below the official limit are not reported.

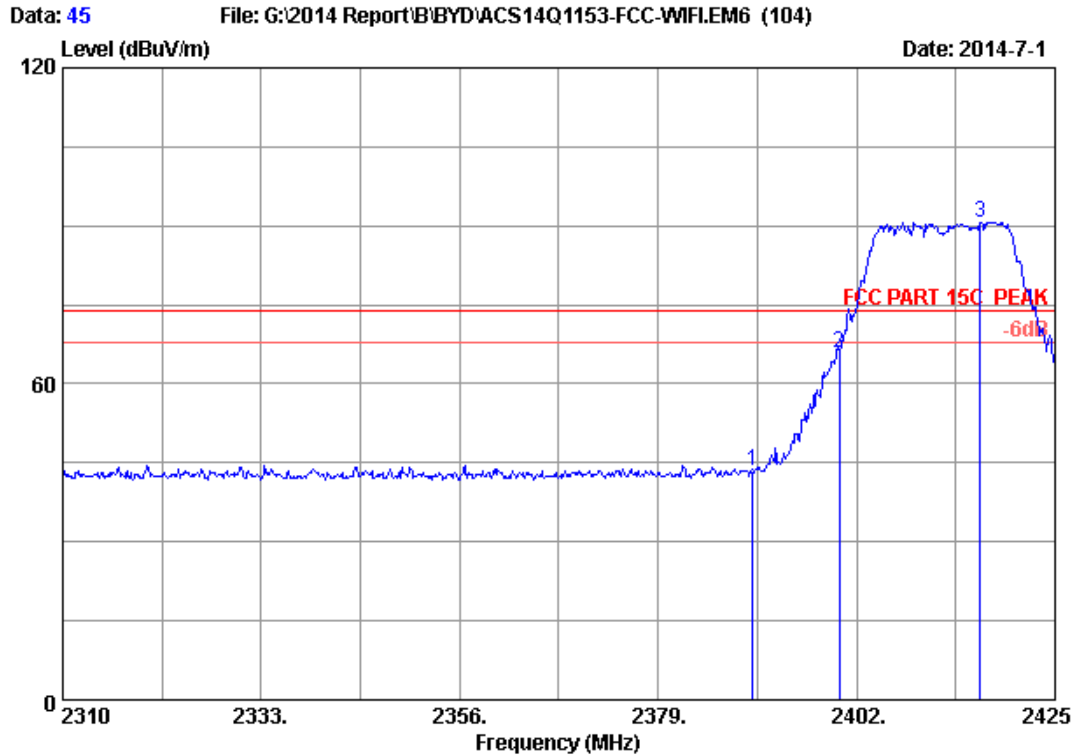

Site no. : 3m Chamber Data no. : 45
 Dis. / Ant. : 3m 2013 3115 (4580) Ant. pol. : VERTICAL
 Limit : FCC PART 15C PEAK
 Env. / Ins. : 24°C/56% Engineer : Kevin_Hu
 EUT : Tablet PC
 Power Rating : DC 5V From Adapter Input AC 120V/60Hz
 Test Mode : IEEE802.11g 2412MHz Tx Mode
 M/N : WT7-C

No.	Freq. (MHz)	Ant. Factor (dB/m)	Cable Loss (dB)	AMP factor (dB)	Reading (dBuV)	Emission Level (dBuV/m)	Limits (dBuV/m)	Margin (dB)	Remark
1	2390.000	28.16	5.78	35.70	45.19	43.43	74.00	30.57	Peak
2	2400.000	28.18	5.80	35.70	67.57	65.85	74.00	8.15	Peak
3	2416.375	28.22	5.82	35.70	92.41	90.75	74.00	-16.75	Peak

Remarks: 1. Emission Level= Antenna Factor + Cable Loss + Reading - Amp Factor
 2. The emission levels that are 20dB below the official limit are not reported.

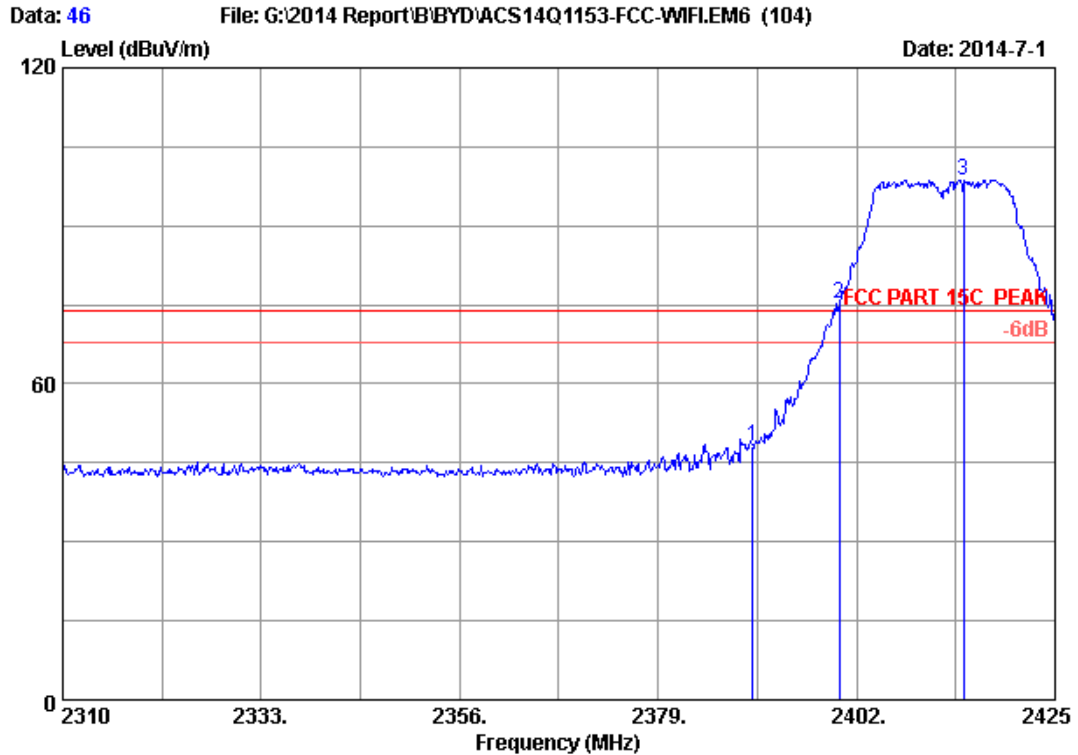

Site no. : 3m Chamber Data no. : 46
 Dis. / Ant. : 3m 2013 3115 (4580) Ant. pol. : HORIZONTAL
 Limit : FCC PART 15C PEAK
 Env. / Ins. : 24°C/56% Engineer : Kevin_Hu
 EUT : Tablet PC
 Power Rating : DC 5V From Adapter Input AC 120V/60Hz
 Test Mode : IEEE802.11g 2412MHz Tx Mode
 M/N : WT7-C

No.	Freq. (MHz)	Ant. Factor (dB/m)	Cable Loss (dB)	AMP factor (dB)	Reading (dBuV)	Emission Level (dBuV/m)	Limits (dBuV/m)	Margin (dB)	Remark
1	2390.000	28.16	5.78	35.70	49.86	48.10	74.00	25.90	Peak
2	2400.000	28.18	5.80	35.70	76.90	75.18	74.00	-1.18	Peak
3	2414.420	28.21	5.82	35.70	100.42	98.75	74.00	-24.75	Peak

Remarks: 1. Emission Level= Antenna Factor + Cable Loss + Reading - Amp Factor
 2. The emission levels that are 20dB below the official limit are not reported.

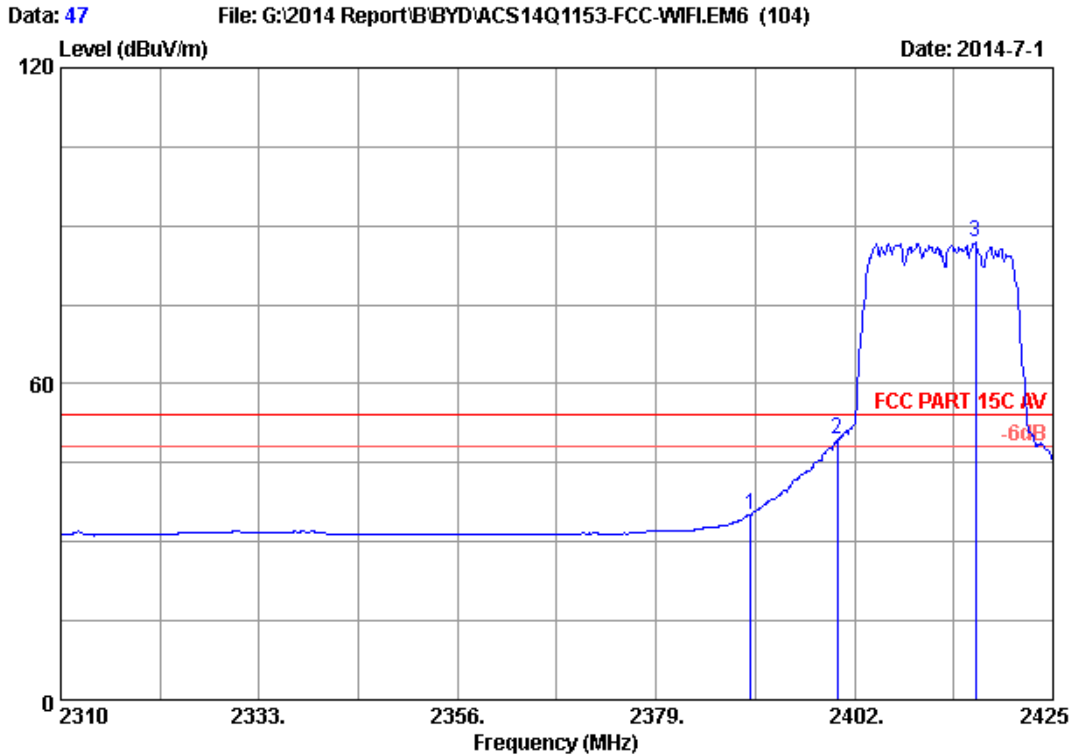

Site no. : 3m Chamber Data no. : 47
 Dis. / Ant. : 3m 2013 3115 (4580) Ant. pol. : HORIZONTAL
 Limit : FCC PART 15C AV
 Env. / Ins. : 24°C/56% Engineer : Kevin_Hu
 EUT : Tablet PC
 Power Rating : DC 5V From Adapter Input AC 120V/60Hz
 Test Mode : IEEE802.11g 2412MHz Tx Mode
 M/N : WT7-C

No.	Freq. (MHz)	Ant. Factor (dB/m)	Cable Loss (dB)	AMP factor (dB)	Reading (dBuV)	Emission Level (dBuV/m)	Limits (dBuV/m)	Margin (dB)	Remark
1	2390.000	28.16	5.78	35.70	37.02	35.26	54.00	18.74	Average
2	2400.000	28.18	5.80	35.70	51.16	49.44	54.00	4.56	Average
3	2416.030	28.22	5.82	35.70	88.41	86.75	54.00	-32.75	Average

Remarks: 1. Emission Level= Antenna Factor + Cable Loss + Reading - Amp Factor
 2. The emission levels that are 20dB below the official limit are not reported.

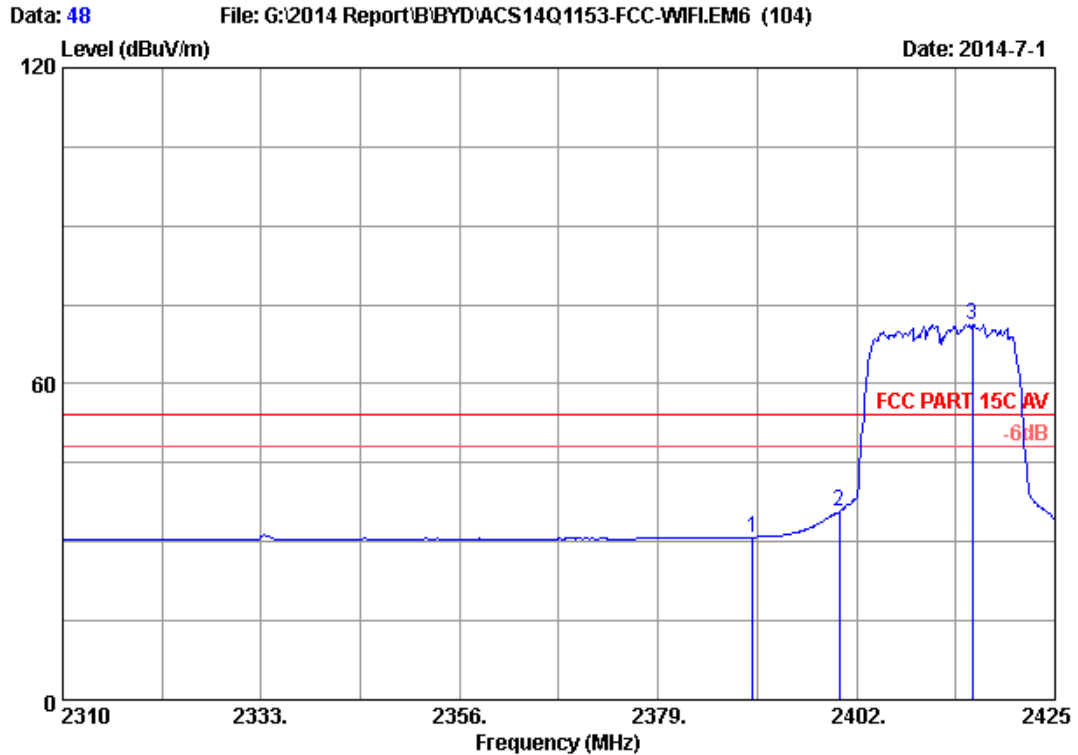

Site no. : 3m Chamber Data no. : 48
 Dis. / Ant. : 3m 2013 3115 (4580) Ant. pol. : VERTICAL
 Limit : FCC PART 15C AV
 Env. / Ins. : 24°C/56% Engineer : Kevin_Hu
 EUT : Tablet PC
 Power Rating : DC 5V From Adapter Input AC 120V/60Hz
 Test Mode : IEEE802.11g 2412MHz Tx Mode
 M/N : WT7-C

No.	Freq. (MHz)	Ant. Factor (dB/m)	Cable Loss (dB)	AMP factor (dB)	Reading (dBuV)	Emission Level (dBuV/m)	Limits (dBuV/m)	Margin (dB)	Remark
1	2390.000	28.16	5.78	35.70	32.63	30.87	54.00	23.13	Average
2	2400.000	28.18	5.80	35.70	37.60	35.88	54.00	18.12	Average
3	2415.455	28.21	5.82	35.70	72.97	71.30	54.00	-17.30	Average

Remarks: 1. Emission Level= Antenna Factor + Cable Loss + Reading - Amp Factor
 2. The emission levels that are 20dB below the official limit are not reported.

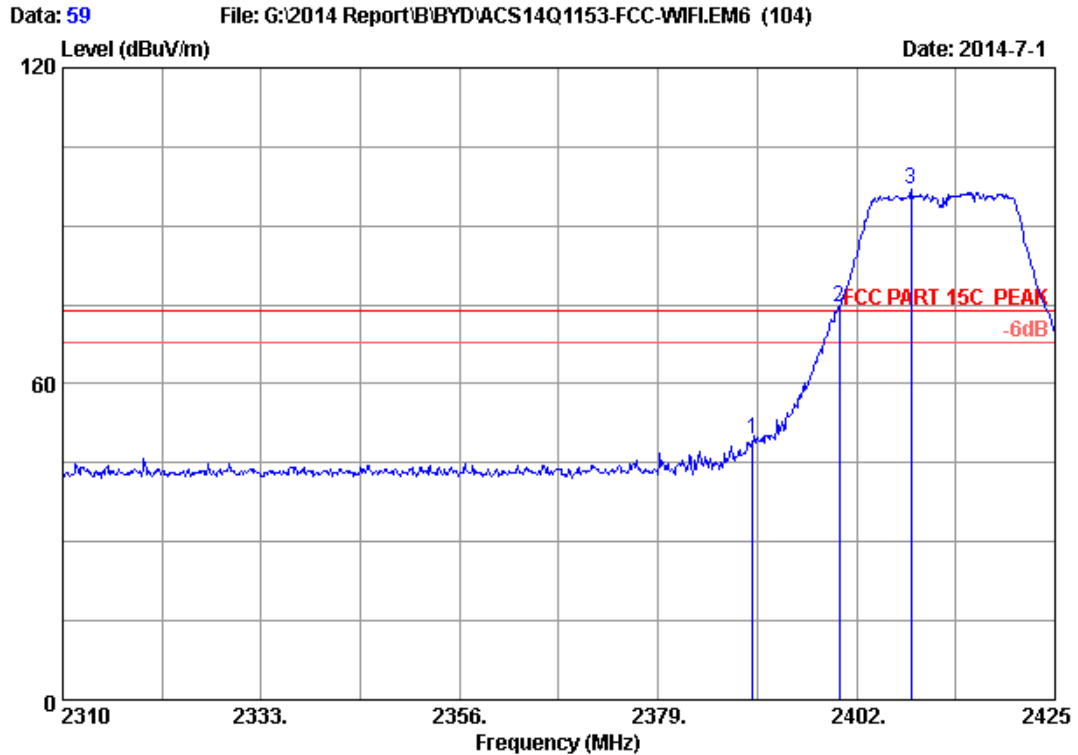

Site no. : 3m Chamber Data no. : 59
 Dis. / Ant. : 3m 2013 3115 (4580) Ant. pol. : HORIZONTAL
 Limit : FCC PART 15C PEAK
 Env. / Ins. : 24°C/56% Engineer : Kevin_Hu
 EUT : Tablet PC
 Power Rating : DC 5V From Adapter Input AC 120V/60Hz
 Test Mode : IEEE802.11nHT20 2412MHz Tx Mode
 M/N : WT7-C

No.	Freq. (MHz)	Ant. Factor (dB/m)	Cable Loss (dB)	AMP factor (dB)	Reading (dBuV)	Emission Level (dBuV/m)	Limits (dBuV/m)	Margin (dB)	Remark
1	2390.000	28.16	5.78	35.70	51.10	49.34	74.00	24.66	Peak
2	2400.000	28.18	5.80	35.70	76.18	74.46	74.00	-0.46	Peak
3	2408.325	28.20	5.81	35.70	98.46	96.77	74.00	-22.77	Peak

Remarks: 1. Emission Level= Antenna Factor + Cable Loss + Reading - Amp Factor
 2. The emission levels that are 20dB below the official limit are not reported.

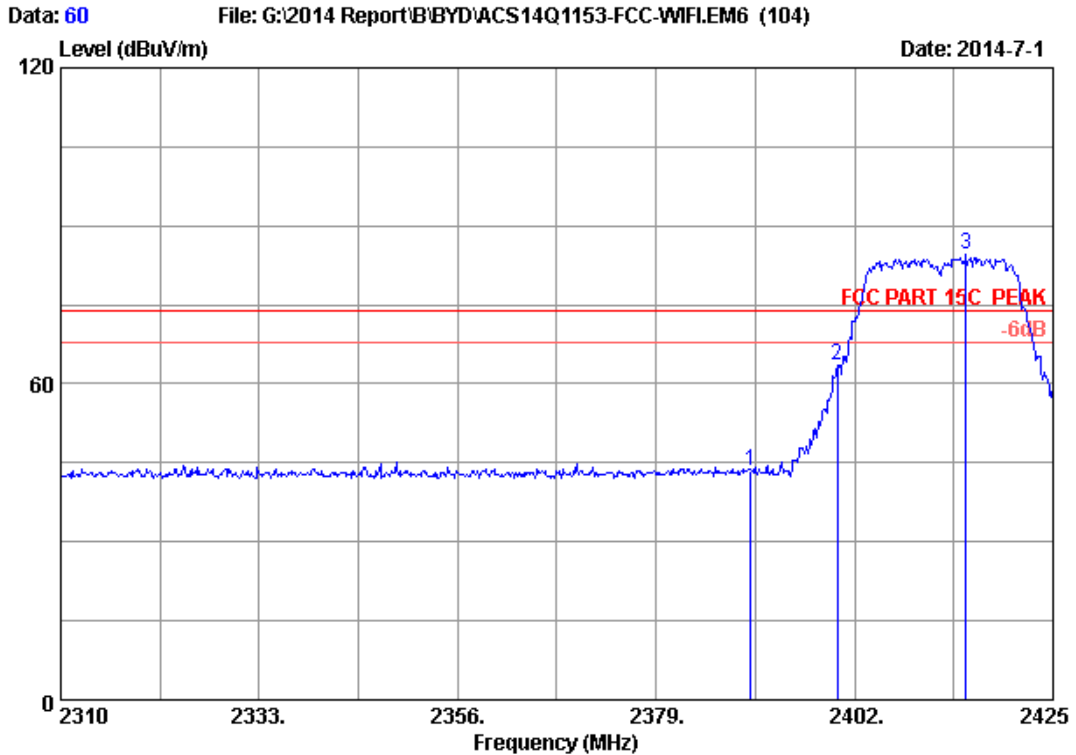

Site no. : 3m Chamber Data no. : 60
 Dis. / Ant. : 3m 2013 3115 (4580) Ant. pol. : VERTICAL
 Limit : FCC PART 15C PEAK
 Env. / Ins. : 24°C/56% Engineer : Kevin_Hu
 EUT : Tablet PC
 Power Rating : DC 5V From Adapter Input AC 120V/60Hz
 Test Mode : IEEE802.11nHT20 2412MHz Tx Mode
 M/N : WT7-C

No.	Freq. (MHz)	Ant. Factor (dB/m)	Cable Loss (dB)	AMP factor (dB)	Reading (dBuV)	Emission Level (dBuV/m)	Limits (dBuV/m)	Margin (dB)	Remark
1	2390.000	28.16	5.78	35.70	45.34	43.58	74.00	30.42	Peak
2	2400.000	28.18	5.80	35.70	65.23	63.51	74.00	10.49	Peak
3	2414.880	28.21	5.82	35.70	86.21	84.54	74.00	-10.54	Peak

Remarks: 1. Emission Level= Antenna Factor + Cable Loss + Reading - Amp Factor
 2. The emission levels that are 20dB below the official limit are not reported.

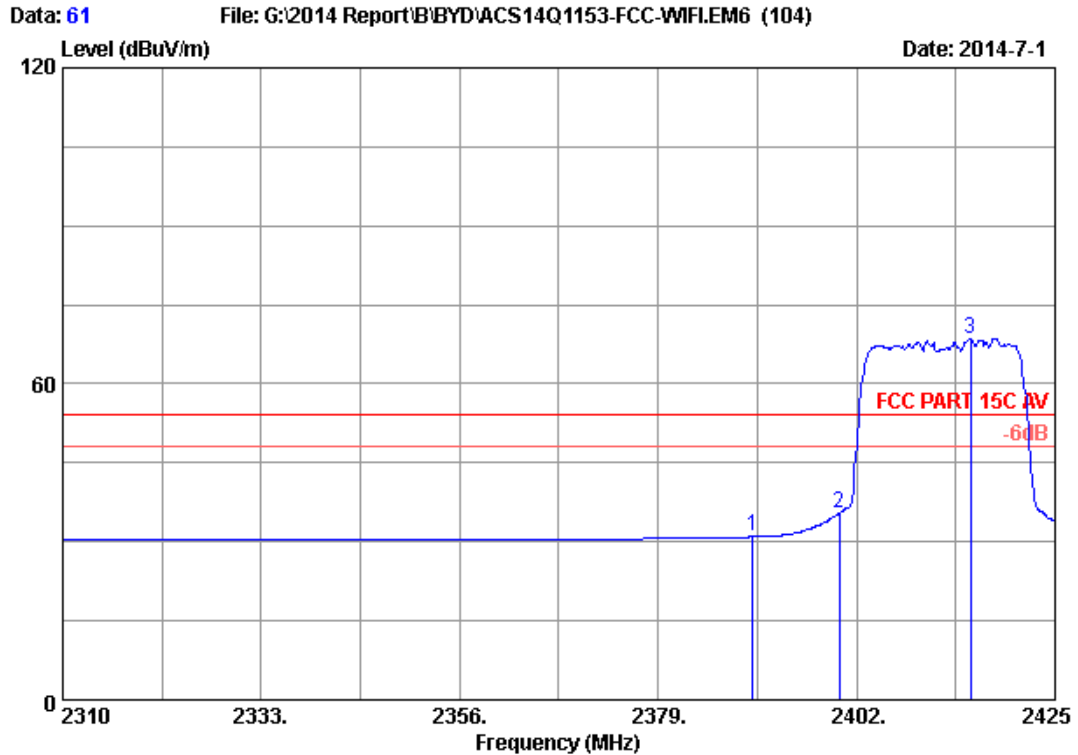

Site no. : 3m Chamber Data no. : 61
 Dis. / Ant. : 3m 2013 3115 (4580) Ant. pol. : VERTICAL
 Limit : FCC PART 15C AV
 Env. / Ins. : 24°C/56% Engineer : Kevin_Hu
 EUT : Tablet PC
 Power Rating : DC 5V From Adapter Input AC 120V/60Hz
 Test Mode : IEEE802.11nHT20 2412MHz Tx Mode
 M/N : WT7-C

No.	Freq. (MHz)	Ant. Factor (dB/m)	Cable Loss (dB)	AMP factor (dB)	Reading (dBuV)	Emission Level (dBuV/m)	Limits (dBuV/m)	Margin (dB)	Remark
1	2390.000	28.16	5.78	35.70	32.76	31.00	54.00	23.00	Average
2	2400.000	28.18	5.80	35.70	37.29	35.57	54.00	18.43	Average
3	2415.225	28.21	5.82	35.70	70.32	68.65	54.00	-14.65	Average

Remarks: 1. Emission Level= Antenna Factor + Cable Loss + Reading - Amp Factor
 2. The emission levels that are 20dB below the official limit are not reported.

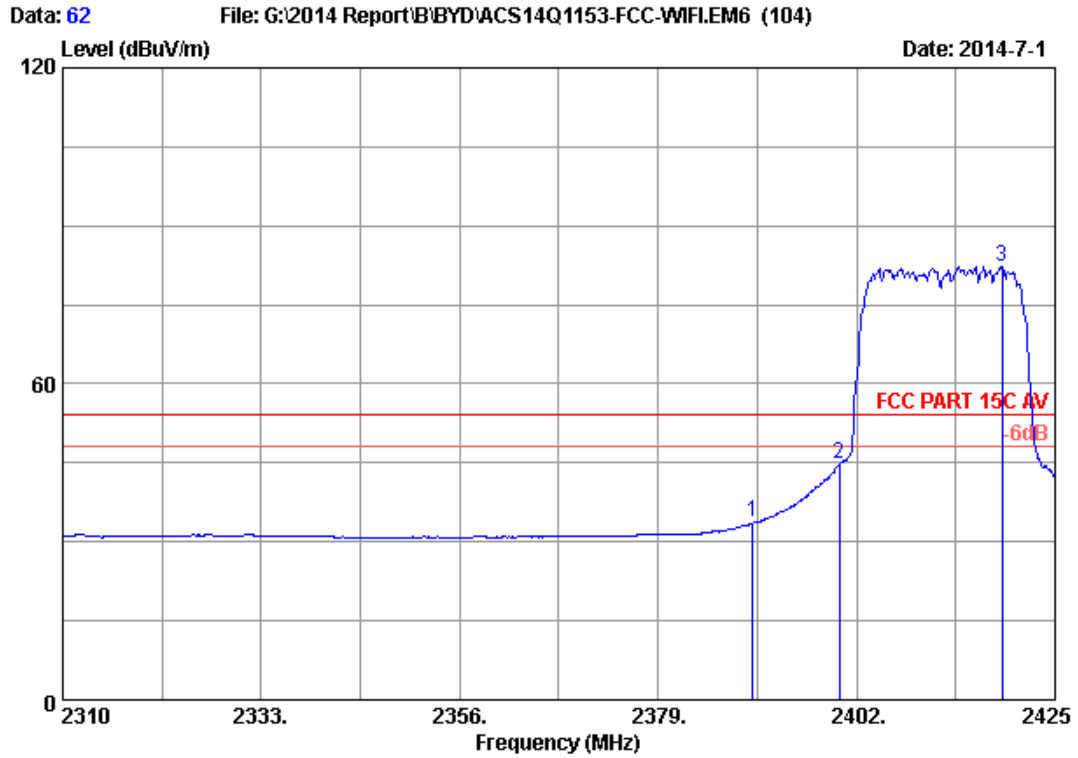

Site no. : 3m Chamber Data no. : 62
 Dis. / Ant. : 3m 2013 3115 (4580) Ant. pol. : HORIZONTAL
 Limit : FCC PART 15C AV
 Env. / Ins. : 24°C/56% Engineer : Kevin_Hu
 EUT : Tablet PC
 Power Rating : DC 5V From Adapter Input AC 120V/60Hz
 Test Mode : IEEE802.11nHT20 2412MHz Tx Mode
 M/N : WT7-C

No.	Freq. (MHz)	Ant. Factor (dB/m)	Cable Loss (dB)	AMP factor (dB)	Reading (dBuV)	Emission Level (dBuV/m)	Limits (dBuV/m)	Margin (dB)	Remark
1	2390.000	28.16	5.78	35.70	35.36	33.60	54.00	20.40	Average
2	2400.000	28.18	5.80	35.70	46.59	44.87	54.00	9.13	Average
3	2418.905	28.22	5.82	35.70	84.01	82.35	54.00	-28.35	Average

Remarks: 1. Emission Level= Antenna Factor + Cable Loss + Reading - Amp Factor
 2. The emission levels that are 20dB below the official limit are not reported.

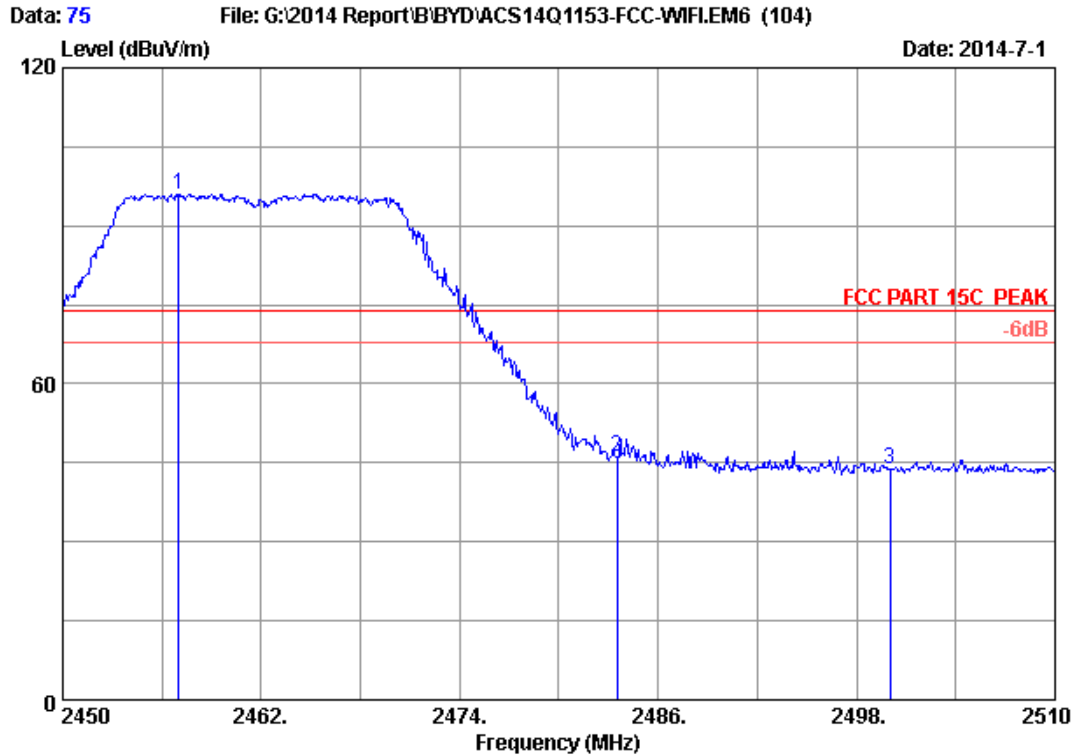

Site no. : 3m Chamber Data no. : 75
 Dis. / Ant. : 3m 2013 3115 (4580) Ant. pol. : HORIZONTAL
 Limit : FCC PART 15C PEAK
 Env. / Ins. : 24°C/56% Engineer : Kevin_Hu
 EUT : Tablet PC
 Power Rating : DC 5V From Adapter Input AC 120V/60Hz
 Test Mode : IEEE802.11nHT20 2462MHz Tx Mode
 M/N : WT7-C

No.	Freq. (MHz)	Ant. Factor (dB/m)	Cable Loss (dB)	AMP factor (dB)	Reading (dBuV)	Emission Level (dBuV/m)	Limits (dBuV/m)	Margin (dB)	Remark
1	2457.020	28.31	5.88	35.70	97.40	95.89	74.00	-21.89	Peak
2	2483.500	28.36	5.92	35.70	47.54	46.12	74.00	27.88	Peak
3	2500.000	28.40	5.94	35.70	45.17	43.81	74.00	30.19	Peak

Remarks: 1. Emission Level= Antenna Factor + Cable Loss + Reading - Amp Factor
 2. The emission levels that are 20dB below the official limit are not reported.

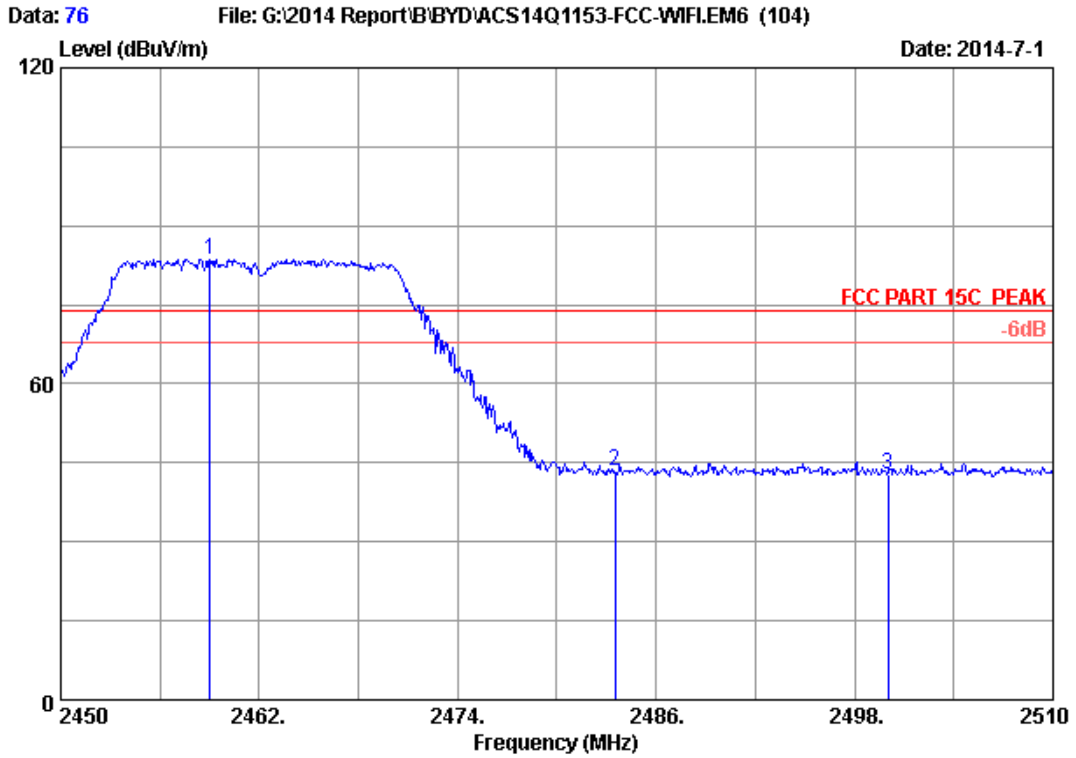

Site no. : 3m Chamber Data no. : 76
 Dis. / Ant. : 3m 2013 3115 (4580) Ant. pol. : VERTICAL
 Limit : FCC PART 15C PEAK
 Env. / Ins. : 24°C/56% Engineer : Kevin_Hu
 EUT : Tablet PC
 Power Rating : DC 5V From Adapter Input AC 120V/60Hz
 Test Mode : IEEE802.11nHT20 2462MHz Tx Mode
 M/N : WT7-C

No.	Freq. (MHz)	Ant. Factor (dB/m)	Cable Loss (dB)	AMP factor (dB)	Reading (dBuV)	Emission Level (dBuV/m)	Limits (dBuV/m)	Margin (dB)	Remark
1	2459.000	28.31	5.88	35.70	85.23	83.72	74.00	-9.72	Peak
2	2483.500	28.36	5.92	35.70	45.04	43.62	74.00	30.38	Peak
3	2500.000	28.40	5.94	35.70	44.24	42.88	74.00	31.12	Peak

Remarks: 1. Emission Level= Antenna Factor + Cable Loss + Reading
 -Amp Factor
 2. The emission levels that are 20dB below the official limit are not reported.

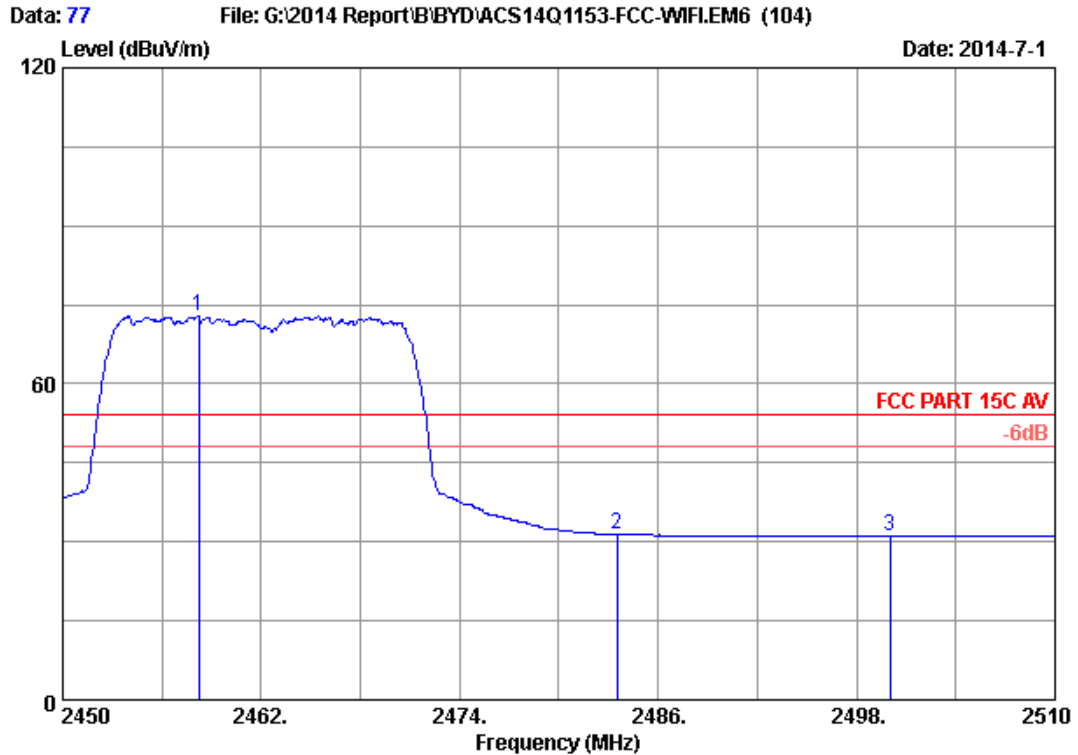

Site no. : 3m Chamber Data no. : 77
 Dis. / Ant. : 3m 2013 3115 (4580) Ant. pol. : VERTICAL
 Limit : FCC PART 15C AV
 Env. / Ins. : 24°C/56% Engineer : Kevin_Hu
 EUT : Tablet PC
 Power Rating : DC 5V From Adapter Input AC 120V/60Hz
 Test Mode : IEEE802.11nHT20 2462MHz Tx Mode
 M/N : WT7-C

No.	Freq. (MHz)	Ant. Factor (dB/m)	Cable Loss (dB)	AMP factor (dB)	Reading (dBuV)	Emission Level (dBuV/m)	Limits (dBuV/m)	Margin (dB)	Remark
1	2458.220	28.31	5.88	35.70	74.42	72.91	54.00	-18.91	Average
2	2483.500	28.36	5.92	35.70	32.78	31.36	54.00	22.64	Average
3	2500.000	28.40	5.94	35.70	32.40	31.04	54.00	22.96	Average

Remarks: 1. Emission Level= Antenna Factor + Cable Loss + Reading - Amp Factor
 2. The emission levels that are 20dB below the official limit are not reported.

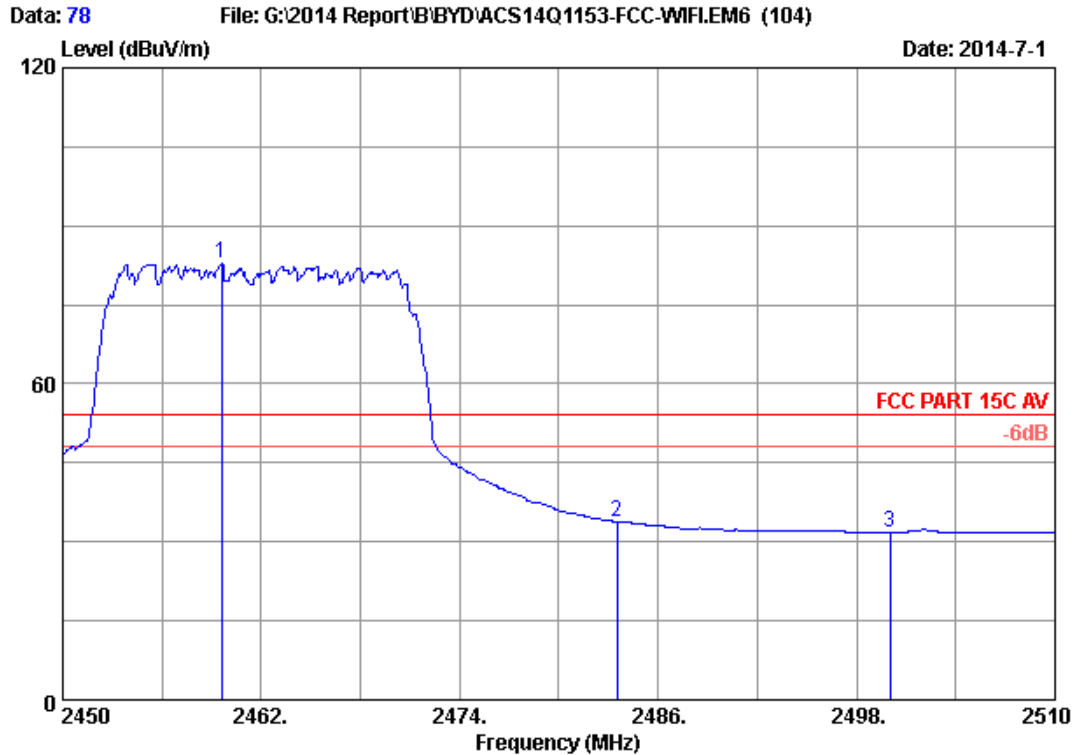

Site no. : 3m Chamber Data no. : 78
 Dis. / Ant. : 3m 2013 3115 (4580) Ant. pol. : HORIZONTAL
 Limit : FCC PART 15C AV
 Env. / Ins. : 24°C/56% Engineer : Kevin_Hu
 EUT : Tablet PC
 Power Rating : DC 5V From Adapter Input AC 120V/60Hz
 Test Mode : IEEE802.11nHT20 2462MHz Tx Mode
 M/N : WT7-C

No.	Freq. (MHz)	Ant. Factor (dB/m)	Cable Loss (dB)	AMP factor (dB)	Reading (dBuV)	Emission Level (dBuV/m)	Limits (dBuV/m)	Margin (dB)	Remark
1	2459.600	28.31	5.88	35.70	84.34	82.83	54.00	-28.83	Average
2	2483.500	28.36	5.92	35.70	35.22	33.80	54.00	20.20	Average
3	2500.000	28.40	5.94	35.70	33.10	31.74	54.00	22.26	Average

Remarks: 1. Emission Level= Antenna Factor + Cable Loss + Reading - Amp Factor
 2. The emission levels that are 20dB below the official limit are not reported.

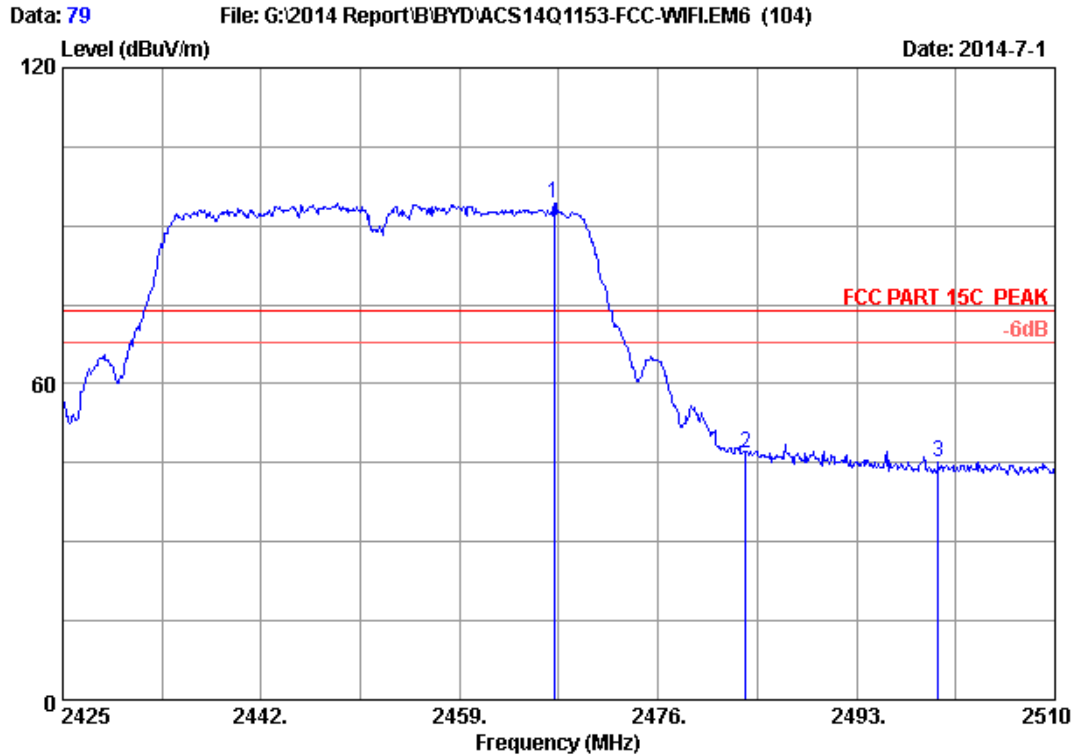

Site no. : 3m Chamber Data no. : 79
 Dis. / Ant. : 3m 2013 3115 (4580) Ant. pol. : HORIZONTAL
 Limit : FCC PART 15C PEAK
 Env. / Ins. : 24°C/56% Engineer : Kevin_Hu
 EUT : Tablet PC
 Power Rating : DC 5V From Adapter Input AC 120V/60Hz
 Test Mode : IEEE802.11nHT40 2452MHz Tx Mode
 M/N : WT7-C

No.	Freq. (MHz)	Ant. Factor (dB/m)	Cable Loss (dB)	AMP factor (dB)	Reading (dBuV)	Emission Level (dBuV/m)	Limits (dBuV/m)	Margin (dB)	Remark
1	2467.075	28.33	5.89	35.70	95.70	94.22	74.00	-20.22	Peak
2	2483.500	28.36	5.92	35.70	48.36	46.94	74.00	27.06	Peak
3	2500.000	28.40	5.94	35.70	46.58	45.22	74.00	28.78	Peak

Remarks: 1. Emission Level= Antenna Factor + Cable Loss + Reading - Amp Factor
 2. The emission levels that are 20dB below the official limit are not reported.

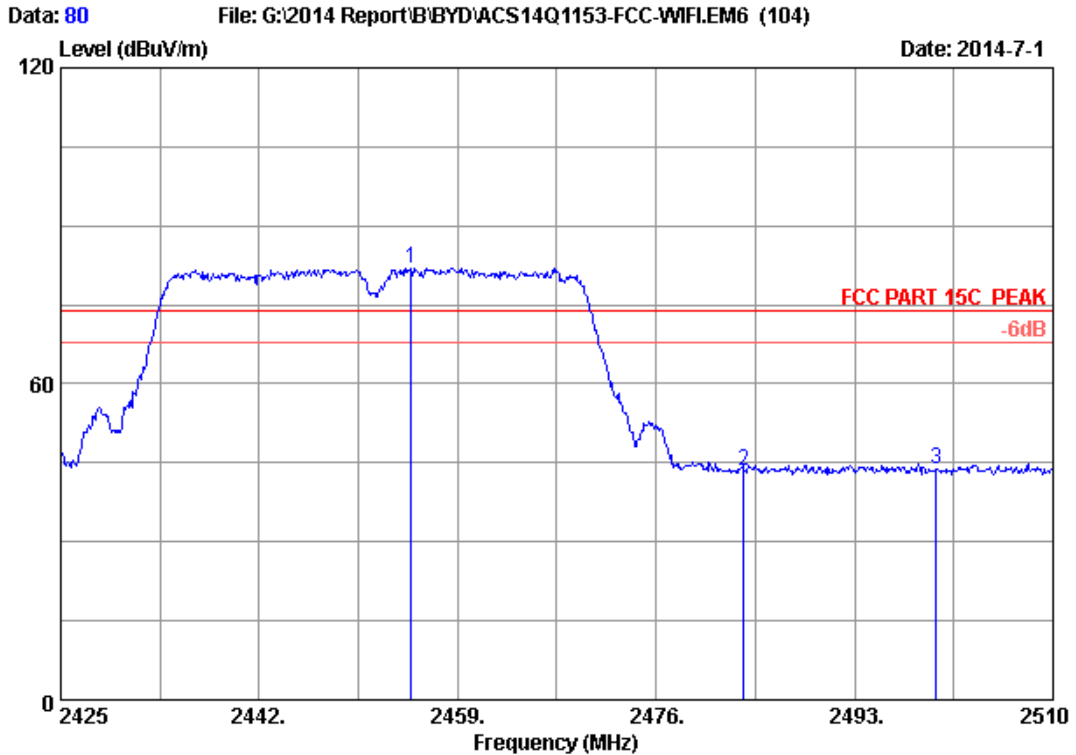

Site no. : 3m Chamber Data no. : 80
 Dis. / Ant. : 3m 2013 3115 (4580) Ant. pol. : VERTICAL
 Limit : FCC PART 15C PEAK
 Env. / Ins. : 24°C/56% Engineer : Kevin_Hu
 EUT : Tablet PC
 Power Rating : DC 5V From Adapter Input AC 120V/60Hz
 Test Mode : IEEE802.11nHT40 2452MHz Tx Mode
 M/N : WT7-C

No.	Freq. (MHz)	Ant. Factor (dB/m)	Cable Loss (dB)	AMP factor (dB)	Reading (dBuV)	Emission Level (dBuV/m)	Limits (dBuV/m)	Margin (dB)	Remark
1	2455.005	28.30	5.88	35.70	83.50	81.98	74.00	-7.98	Peak
2	2483.500	28.36	5.92	35.70	44.80	43.38	74.00	30.62	Peak
3	2500.000	28.40	5.94	35.70	45.22	43.86	74.00	30.14	Peak

Remarks: 1. Emission Level= Antenna Factor + Cable Loss + Reading - Amp Factor
 2. The emission levels that are 20dB below the official limit are not reported.

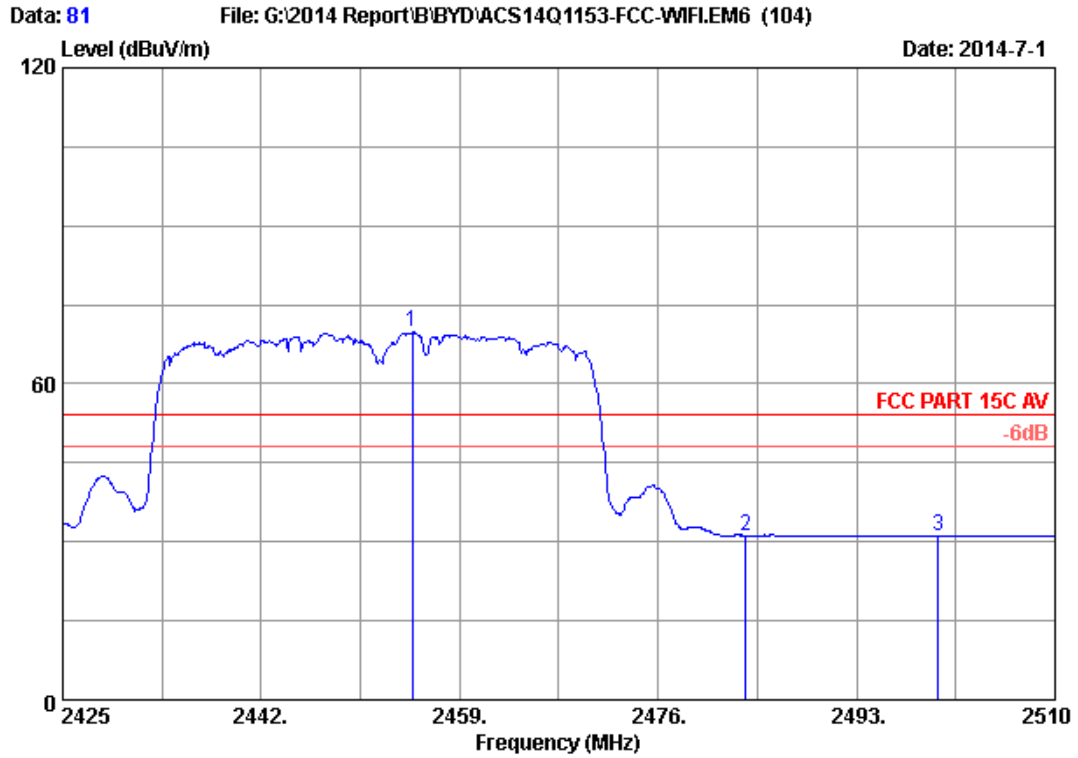

Site no. : 3m Chamber Data no. : 81
 Dis. / Ant. : 3m 2013 3115 (4580) Ant. pol. : VERTICAL
 Limit : FCC PART 15C AV
 Env. / Ins. : 24°C/56% Engineer : Kevin_Hu
 EUT : Tablet PC
 Power Rating : DC 5V From Adapter Input AC 120V/60Hz
 Test Mode : IEEE802.11nHT40 2452MHz Tx Mode
 M/N : WT7-C

No.	Freq. (MHz)	Ant. Factor (dB/m)	Cable Loss (dB)	AMP factor (dB)	Reading (dBuV)	Emission Level (dBuV/m)	Limits (dBuV/m)	Margin (dB)	Remark
1	2454.920	28.30	5.88	35.70	71.27	69.75	54.00	-15.75	Average
2	2483.500	28.36	5.92	35.70	32.65	31.23	54.00	22.77	Average
3	2500.000	28.40	5.94	35.70	32.40	31.04	54.00	22.96	Average

Remarks: 1. Emission Level= Antenna Factor + Cable Loss + Reading
 -Amp Factor
 2. The emission levels that are 20dB below the official limit are not reported.

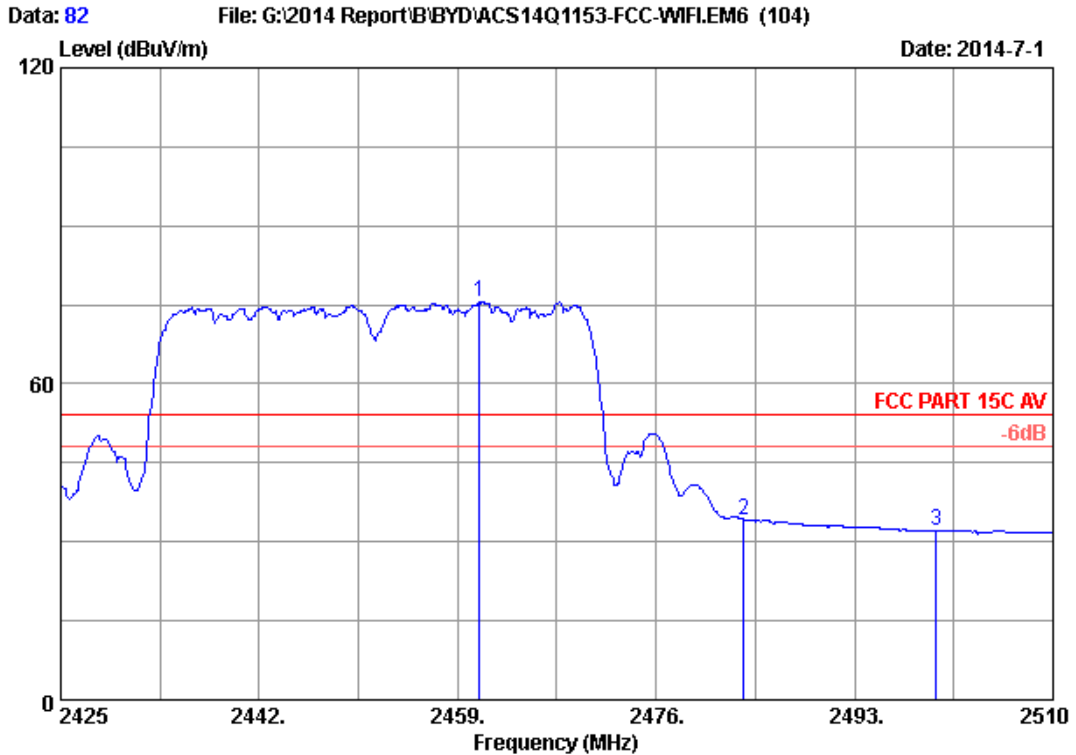

Site no. : 3m Chamber Data no. : 82
 Dis. / Ant. : 3m 2013 3115 (4580) Ant. pol. : HORIZONTAL
 Limit : FCC PART 15C AV
 Env. / Ins. : 24°C/56% Engineer : Kevin_Hu
 EUT : Tablet PC
 Power Rating : DC 5V From Adapter Input AC 120V/60Hz
 Test Mode : IEEE802.11nHT40 2452MHz Tx Mode
 M/N : WT7-C

No.	Freq. (MHz)	Ant. Factor (dB/m)	Cable Loss (dB)	AMP factor (dB)	Reading (dBuV)	Emission Level (dBuV/m)	Limits (dBuV/m)	Margin (dB)	Remark
1	2460.870	28.31	5.89	35.70	77.00	75.50	54.00	-21.50	Average
2	2483.500	28.36	5.92	35.70	35.58	34.16	54.00	19.84	Average
3	2500.000	28.40	5.94	35.70	33.35	31.99	54.00	22.01	Average

Remarks: 1. Emission Level= Antenna Factor + Cable Loss + Reading - Amp Factor
 2. The emission levels that are 20dB below the official limit are not reported.

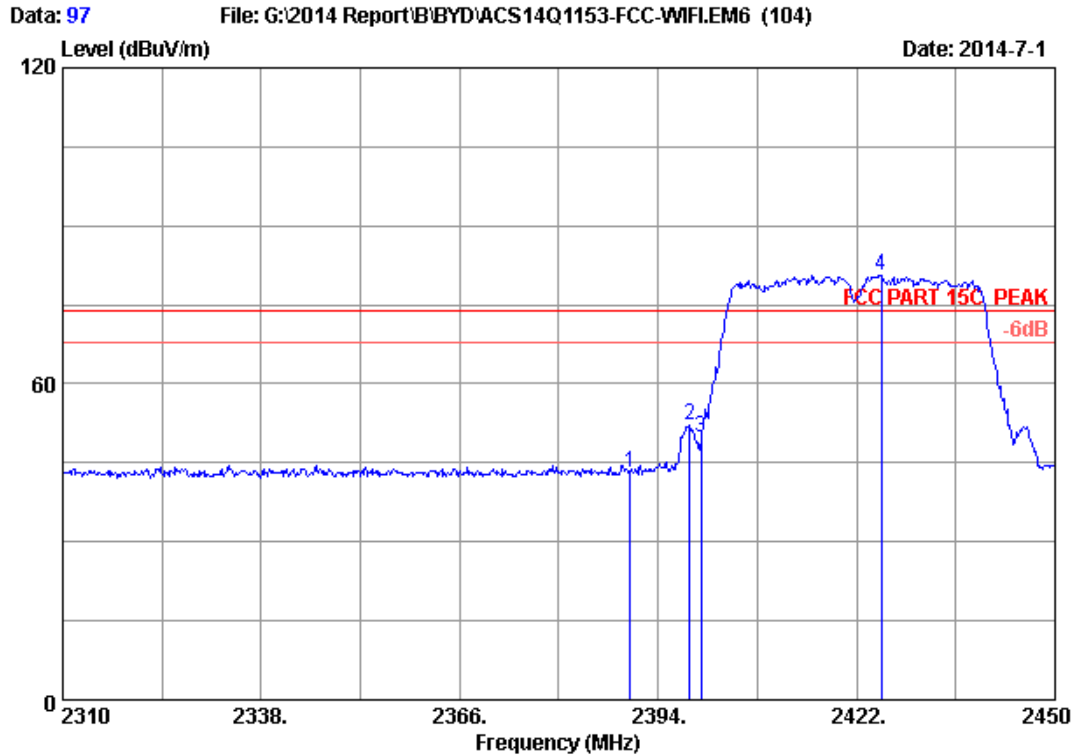

Site no. : 3m Chamber Data no. : 97
 Dis. / Ant. : 3m 2013 3115 (4580) Ant. pol. : VERTICAL
 Limit : FCC PART 15C PEAK
 Env. / Ins. : 24°C/56% Engineer : Kevin_Hu
 EUT : Tablet PC
 Power Rating : DC 5V From Adapter Input AC 120V/60Hz
 Test Mode : IEEE802.11nHT40 2422MHz Tx Mode
 M/N : WT7-C

No.	Freq. (MHz)	Ant. Factor (dB/m)	Cable Loss (dB)	AMP factor (dB)	Reading (dBuV)	Emission Level (dBuV/m)	Limits (dBuV/m)	Margin (dB)	Remark
1	2390.000	28.16	5.78	35.70	44.78	43.02	74.00	30.98	Peak
2	2398.480	28.18	5.79	35.70	53.97	52.24	74.00	21.76	Peak
3	2400.000	28.18	5.80	35.70	51.52	49.80	74.00	24.20	Peak
4	2425.500	28.24	5.83	35.70	82.11	80.48	74.00	-6.48	Peak

Remarks: 1. Emission Level= Antenna Factor + Cable Loss + Reading - Amp Factor
 2. The emission levels that are 20dB below the official limit are not reported.

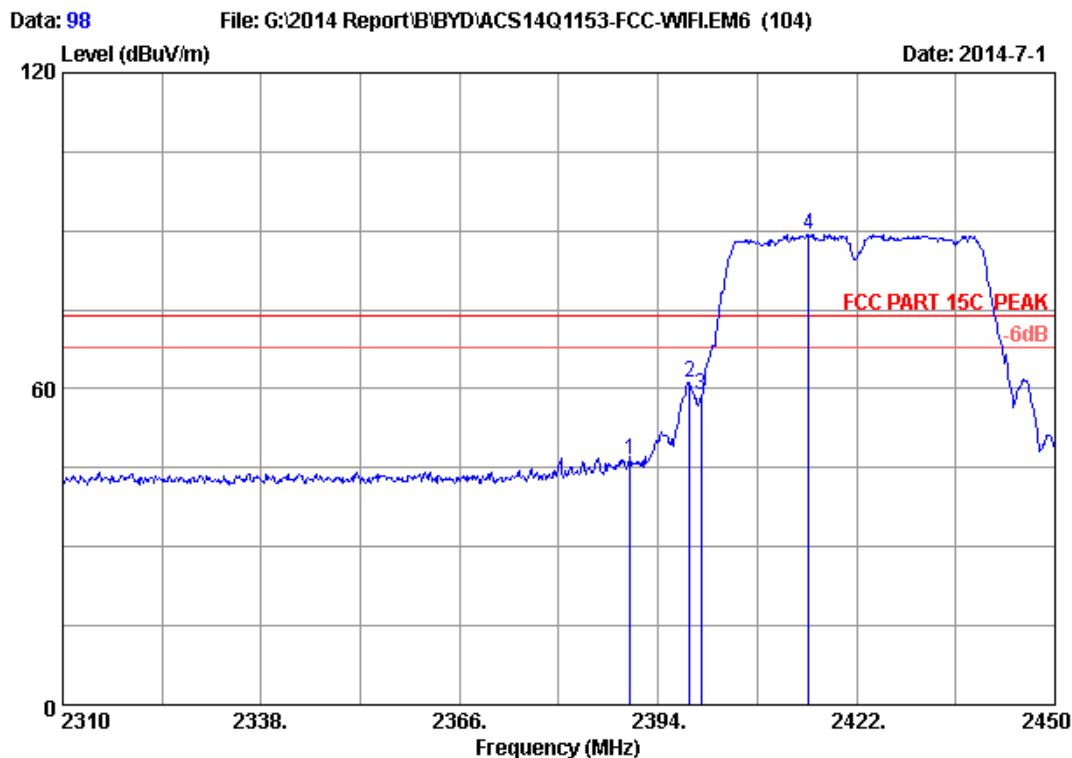

Site no. : 3m Chamber Data no. : 98
 Dis. / Ant. : 3m 2013 3115 (4580) Ant. pol. : HORIZONTAL
 Limit : FCC PART 15C PEAK
 Env. / Ins. : 24°C/56% Engineer : Kevin_Hu
 EUT : Tablet PC
 Power Rating : DC 5V From Adapter Input AC 120V/60Hz
 Test Mode : IEEE802.11nHT40 2422MHz Tx Mode
 M/N : WT7-C

No.	Freq. (MHz)	Ant. Factor (dB/m)	Cable Loss (dB)	AMP factor (dB)	Reading (dBuV)	Emission Level (dBuV/m)	Limits (dBuV/m)	Margin (dB)	Remark
1	2390.000	28.16	5.78	35.70	48.23	46.47	74.00	27.53	Peak
2	2398.480	28.18	5.79	35.70	62.94	61.21	74.00	12.79	Peak
3	2400.000	28.18	5.80	35.70	60.44	58.72	74.00	15.28	Peak
4	2415.280	28.21	5.82	35.70	90.90	89.23	74.00	-15.23	Peak

Remarks: 1. Emission Level= Antenna Factor + Cable Loss + Reading
 -amp Factor
 2. The emission levels that are 20dB below the official limit are not reported.

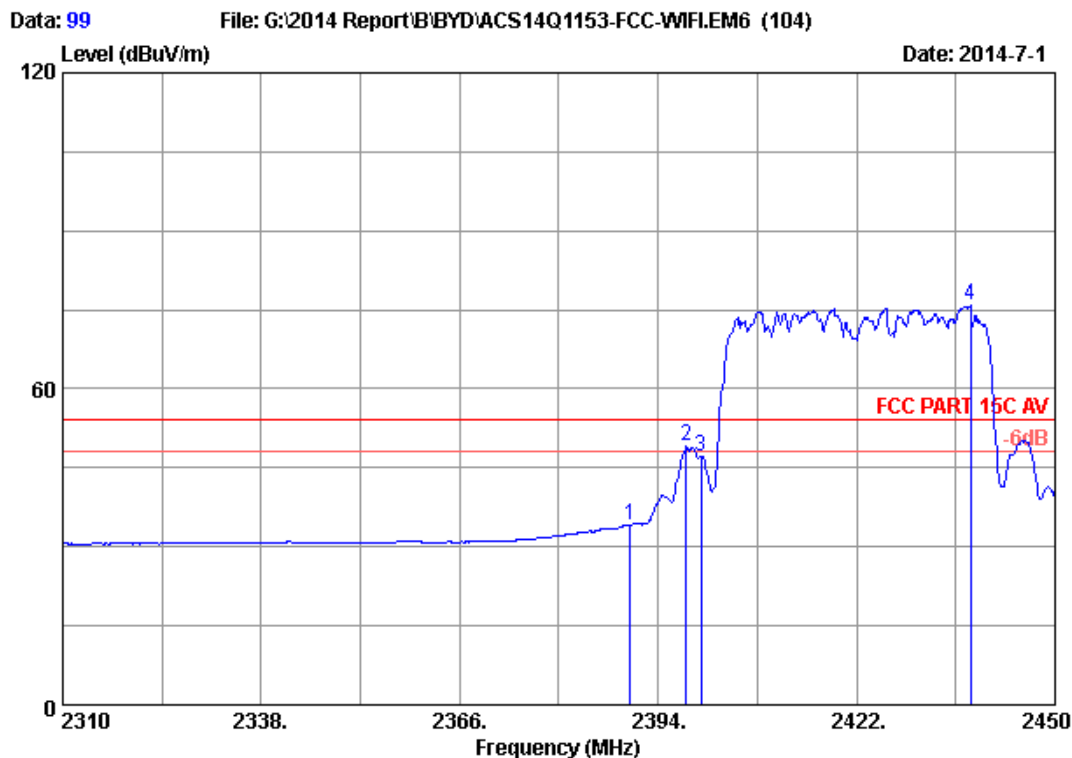

Site no. : 3m Chamber Data no. : 99
 Dis. / Ant. : 3m 2013 3115 (4580) Ant. pol. : HORIZONTAL
 Limit : FCC PART 15C AV
 Env. / Ins. : 24°C/56% Engineer : Kevin_Hu
 EUT : Tablet PC
 Power Rating : DC 5V From Adapter Input AC 120V/60Hz
 Test Mode : IEEE802.11nHT40 2422MHz Tx Mode
 M/N : WT7-C

No.	Freq. (MHz)	Ant. Factor (dB/m)	Cable Loss (dB)	AMP factor (dB)	Reading (dBuV)	Emission Level (dBuV/m)	Limits (dBuV/m)	Margin (dB)	Remark
1	2390.000	28.16	5.78	35.70	35.86	34.10	54.00	19.90	Average
2	2397.920	28.18	5.79	35.70	50.74	49.01	54.00	4.99	Average
3	2400.000	28.18	5.80	35.70	48.94	47.22	54.00	6.78	Average
4	2438.100	28.26	5.85	35.70	77.32	75.73	54.00	-21.73	Average

Remarks: 1. Emission Level= Antenna Factor + Cable Loss + Reading - Amp Factor
 2. The emission levels that are 20dB below the official limit are not reported.

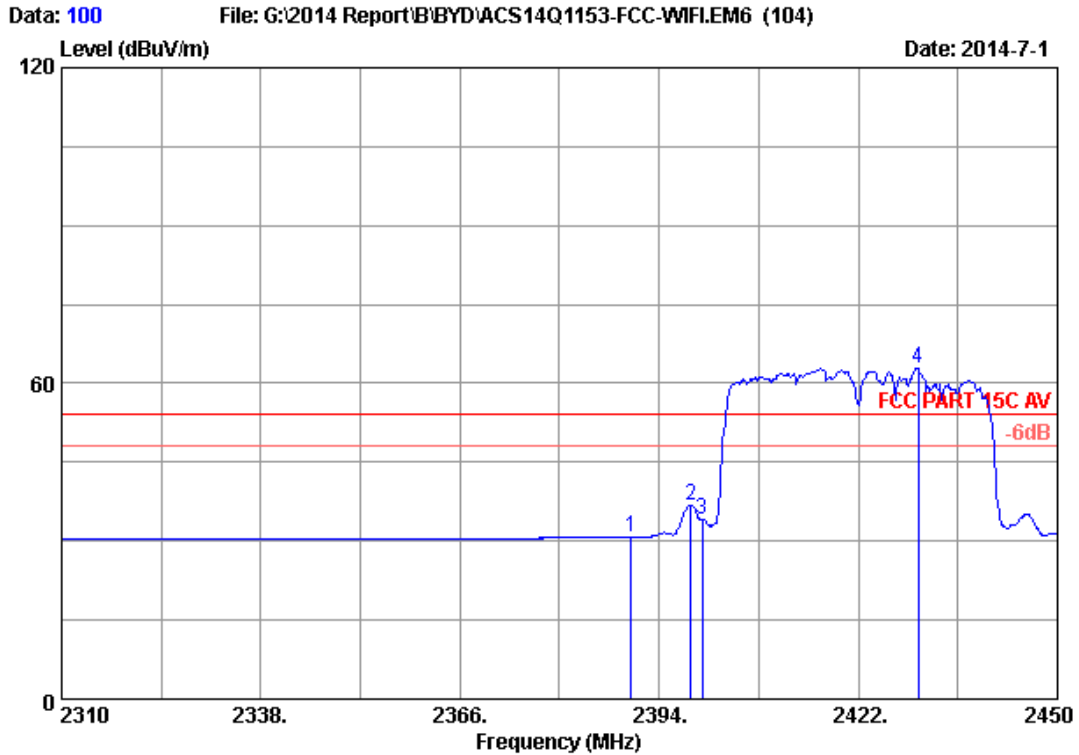

Site no. : 3m Chamber Data no. : 100
 Dis. / Ant. : 3m 2013 3115 (4580) Ant. pol. : HORIZONTAL
 Limit : FCC PART 15C AV
 Env. / Ins. : 24*C/56% Engineer : Kevin_Hu
 EUT : Tablet PC
 Power Rating : DC 5V From Adapter Input AC 120V/60Hz
 Test Mode : IEEE802.11nHT40 2422MHz Tx Mode
 M/N : WT7-C

No.	Freq. (MHz)	Ant. Factor (dB/m)	Cable Loss (dB)	AMP factor (dB)	Reading (dBuV)	Emission Level (dBuV/m)	Limits (dBuV/m)	Margin (dB)	Remark
1	2390.000	28.16	5.78	35.70	32.57	30.81	54.00	23.19	Average
2	2398.480	28.18	5.79	35.70	38.58	36.85	54.00	17.15	Average
3	2400.000	28.18	5.80	35.70	35.83	34.11	54.00	19.89	Average
4	2430.400	28.25	5.84	35.70	64.50	62.89	54.00	-8.89	Average

Remarks: 1. Emission Level= Antenna Factor + Cable Loss + Reading - Amp Factor
 2. The emission levels that are 20dB below the official limit are not reported.

7. 6dB BANDWIDTH Test

7.1. Test Equipment

Item	Equipment	Manufacturer	Model No.	Serial No.	Last Cal.	Cal. Interval
4.	Spectrum Analyzer	Agilent	N9030A	MY51380221	Oct.31, 13	1 Year
5.	Antenna	EMCO	3115	9607-4877	Aug.28, 13	1 Year
6.	HF Cable	Hubersuhner	Sucoflex104	-	May.08, 13	1 Year

7.2. Limit

For direct sequence systems, the minimum 6dB bandwidth shall be at least 500kHz

7.3. Test Procedure

The transmitter output was connected to a spectrum analyzer, The bandwidth of the fundamental frequency was measured by spectrum analyzer with 300KHz RBW and 1MHz VBW. The 6dB bandwidth is defined as the total spectrum the power of which is higher than peak power minus 6dB.

7.4. Test Results

EUT: Tablet PC		
M/N: WT7-C		
Test date: 2014-04-20	Pressure: 101.1±1.0 kpa	Humidity: 49.8±3.0%
Tested by: Kevin_Hu	Test site: RF site	Temperature: 22.5±0.6 °C

Cable loss: 1 dB		Attenuator loss: 20 dB	
Test Mode	CH	6dB bandwidth (MHz)	Limit (KHz)
		Chain 0	
11b	CH1	10.20	>500
	CH6	10.22	>500
	CH11	10.24	>500
11g	CH1	16.52	>500
	CH6	16.53	>500
	CH11	16.52	>500
11n HT20	CH1	17.71	>500
	CH6	17.68	>500
	CH11	17.71	>500
11n HT40	CH1	36.38	>500
	CH4	36.32	>500
	CH7	36.38	>500
Conclusion : PASS			

Test Mode: IEEE 802.11b
 Test CH1: 2412MHz



Test CH6: 2437MHz



Test CH11: 2462MHz



Test Mode: IEEE 802.11g

Test CH1: 2412MHz



Test CH6: 2437MHz



Test CH11: 2462MHz



Test Mode: IEEE 802.11n HT20
 Test CH1: 2412MHz



Test CH6: 2437MHz



Test CH11: 2462MHz



Test Mode: IEEE 802.11n HT40

Test CH1: 2422MHz



Test CH4: 2437MHz

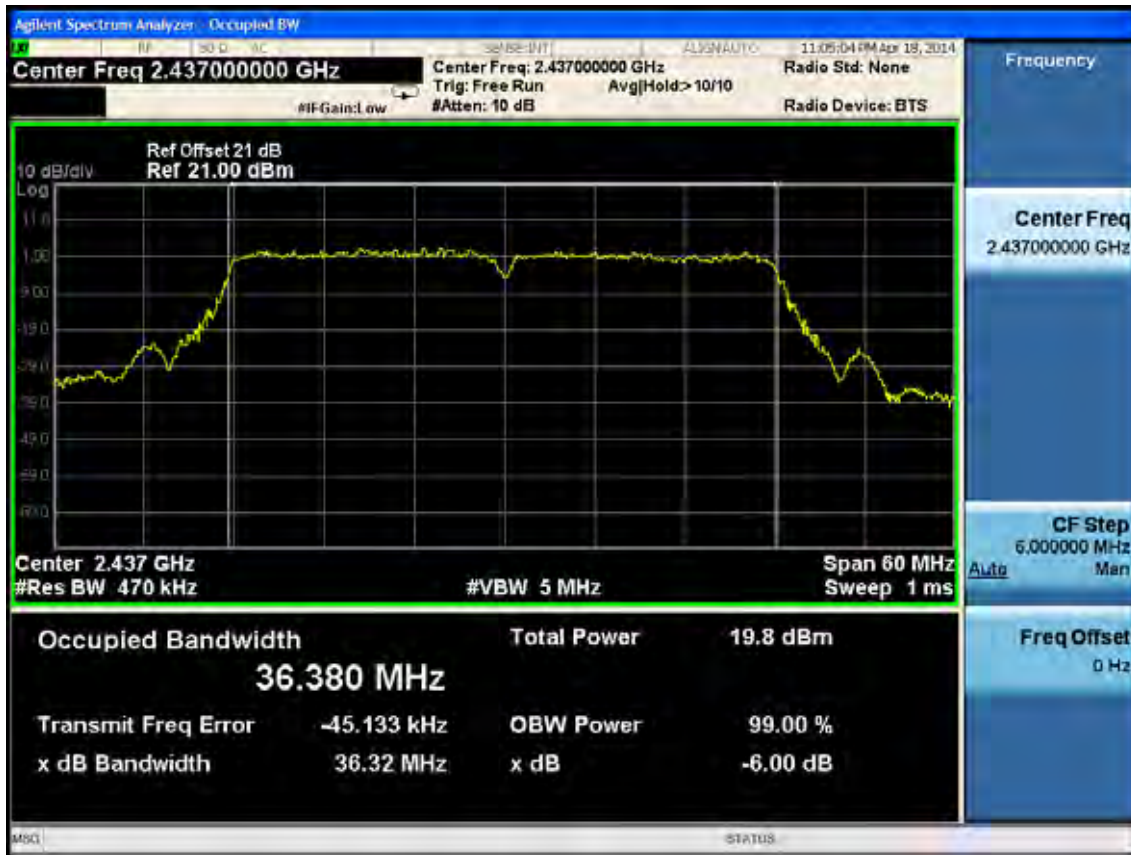

Test CH7: 2452MHz



8. OUTPUT POWER TEST

8.1. Test Equipment

Item	Equipment	Manufacturer	Model No.	Serial No.	Last Cal.	Cal. Interval
1.	Spectrum Analyzer	Agilent	N9030A	MY51380221	Oct.31, 13	1 Year
2.	Amp	HP	8449B	3008A08495	May.08, 13	1 Year
3.	Antenna	EMCO	3115	9607-4877	May.08, 13	1 Year
4.	HF Cable	Hubersuhne	Sucoflex104	-	May.08, 13	1 Year
5.	Power Meter	Anritsu	ML2487A	6K00002472	May.08, 13	1 Year
6.	Power Sensor	Anritsu	MA2491A	033005	May.08, 13	1 Year

8.2. Limit (FCC Part 15C 15.247 b(3))

For systems using digital modulation in the 2400—2483.5MHz, The Peak out put Power shall not exceed 1W(30dBm)

8.3. Test Procedure

- 1, Connected the EUT's antenna port to measure device by 26dB attenuator.
- 2, For IEEE 802.11b/g and IEEE802.11n HT20 mode, use a PK power meter which's bandwidth is 20MHz and above 26dB bandwidth of signal to measure out each test modes' PK output power.
- 3, For IEEE802.11n HT40 mode, because the signal's bandwidth is about 40MHz and above 20MHz bandwidth of power sensor ML2491A. So used the test method per KDB558074.
 - 1) Set the RBW=1MHz and VBW =3MHz
 - 2) Set the span to a value that is 5-30% greater than EBW
 - 3) Detector = peak
 - 4) Sweep time = auto couple
 - 5) Trace Mode = max hold
 - 6) allow trace to fully stabilize
 - 7) use the spectrum analyzer's integrated band power measurement function with band limits set equal to the EBW band edges.

Note: The cable loss and attenuator loss were offset into measure device as an amplitude offset.

8.4. Test Results

EUT:Tablet PC			
M/N:WT7-C			
Test date: 2014-04-20		Pressure: 101.1±1.0 kpa	Humidity: 51.2±3.0%
Tested by: Kevin_Hu		Test site: RF site	Temperature:22.5±0.6 °C
Cable loss: 1 dB		Attenuator loss: 20 dB	
Test Mode	CH	Peak output Power (dBm)	Limit (dBm)
		Chain 0	
11b	CH1	17.78	30
	CH6	17.86	30
	CH11	17.51	30
11g	CH1	22.57	30
	CH6	21.51	30
	CH11	21.05	30
11n HT20	CH1	19.93	30
	CH6	20.73	30
	CH11	20.49	30
11n HT40	CH1	20.94	30
	CH4	20.27	30
	CH7	20.06	30
Conclusion: PASS			

Test Mode: IEEE 802.11n HT40
 Test CH1: 2422MHz



Test CH4: 2437MHz



Test CH7: 2452MHz



9. POWER SPECTRAL DENSITY TEST

9.1. Test Equipment

Item	Equipment	Manufacturer	Model No.	Serial No.	Last Cal.	Cal. Interval
1.	Spectrum Analyzer	Agilent	N9030A	MY51380221	Oct.31, 13	1 Year
2.	Amp	HP	8449B	3008A08495	May.08, 13	1 Year
3.	Antenna	EMCO	3115	9607-4877	Aug.28, 13	1 Year
4.	HF Cable	Hubersuhne	Sucoflex104	-	May.08, 13	1 Year

9.2. Limit

For digitally modulated systems, the power spectral density conducted from the intentional radiator to the antenna shall not be greater than 8dBm in any 3kHz band during any time interval of continuous transmission.

9.3. Test Procedure

1. Connected the EUT's antenna port to spectrum analyzer device by 20dB attenuator.
- 2, Set the test frequency as center frequency, Set RBW=3KHz, VBW=10KHz, Span large enough capture the entire frequency, Read out maximum peak level frequency
- 3, Set the frequency read from produce 2 as center frequency, then set the span=300KHz, Sweep time=Span/RBW, Then Max hold, read out each mode and each chain's Power density.

Note: The cable loss and attenuator loss were offset into measure device as an amplitude

9.4. Test Results

EUT: Tablet PC		
M/N: WT7-C		
Test date: 2014-04-20	Pressure: 101.2±1.0 kpa	Humidity: 51.3±3.0%
Tested by: Kevin_Hu	Test site: RF Site	Temperature : 22.7±0.6°C

Cable loss: 1 dB		Attenuator loss: 20 dB	
Test Mode	CH	Power density (dBm/3KHz)	Limit (dBm/3KHz)
		ANT 0	
11b	CH1	-6.452	8
	CH6	-8.272	8
	CH11	-8.855	8
11g	CH1	-10.817	8
	CH6	-12.497	8
	CH11	-12.799	8
11n Mode			
Test Mode	CH	Power density (dBm/3KHz)	Limit (dBm/3KHz)
		ANT 0	
11n HT20	CH1	-11.995	8
	CH6	-12.540	8
	CH11	-12.556	8
11n HT40	CH1	-13.972	8
	CH4	-18.252	8
	CH7	-17.462	8
Conclusion : PASS			

Test Mode: IEEE 802.11b
Test CH1: 2412MHz

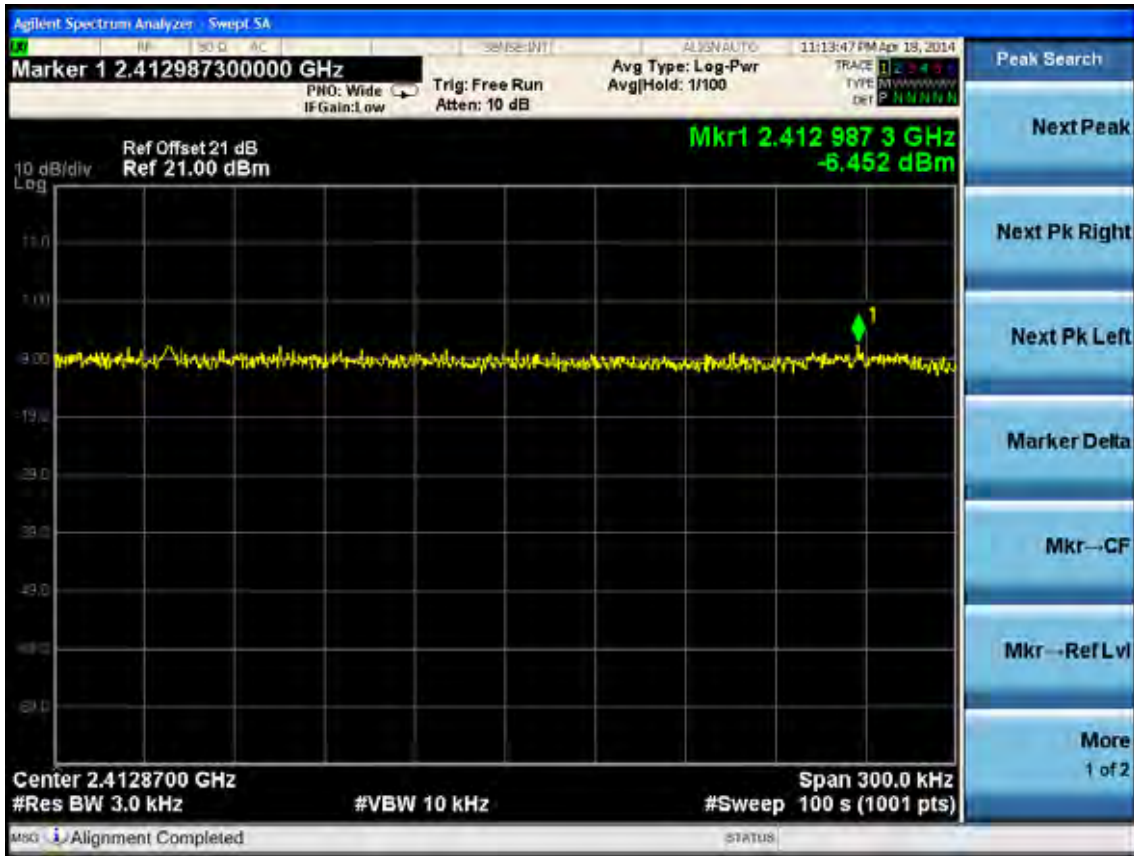

Test CH6: 2437MHz



Test CH11: 2462MHz



Test Mode: IEEE 802.11g

Test CH1: 2412MHz



Test CH6: 2437MHz



Test CH11: 2462MHz

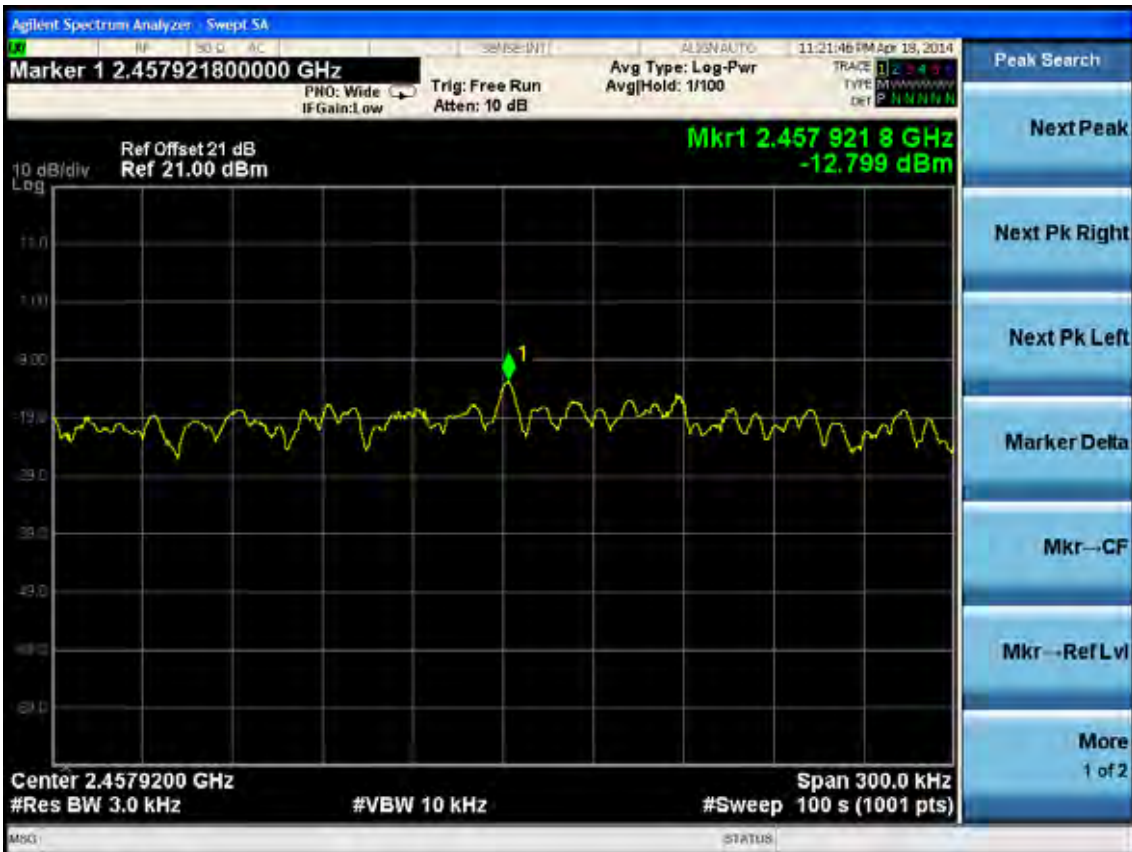

Test Mode: IEEE 802.11n HT20
Test CH1: 2412MHz

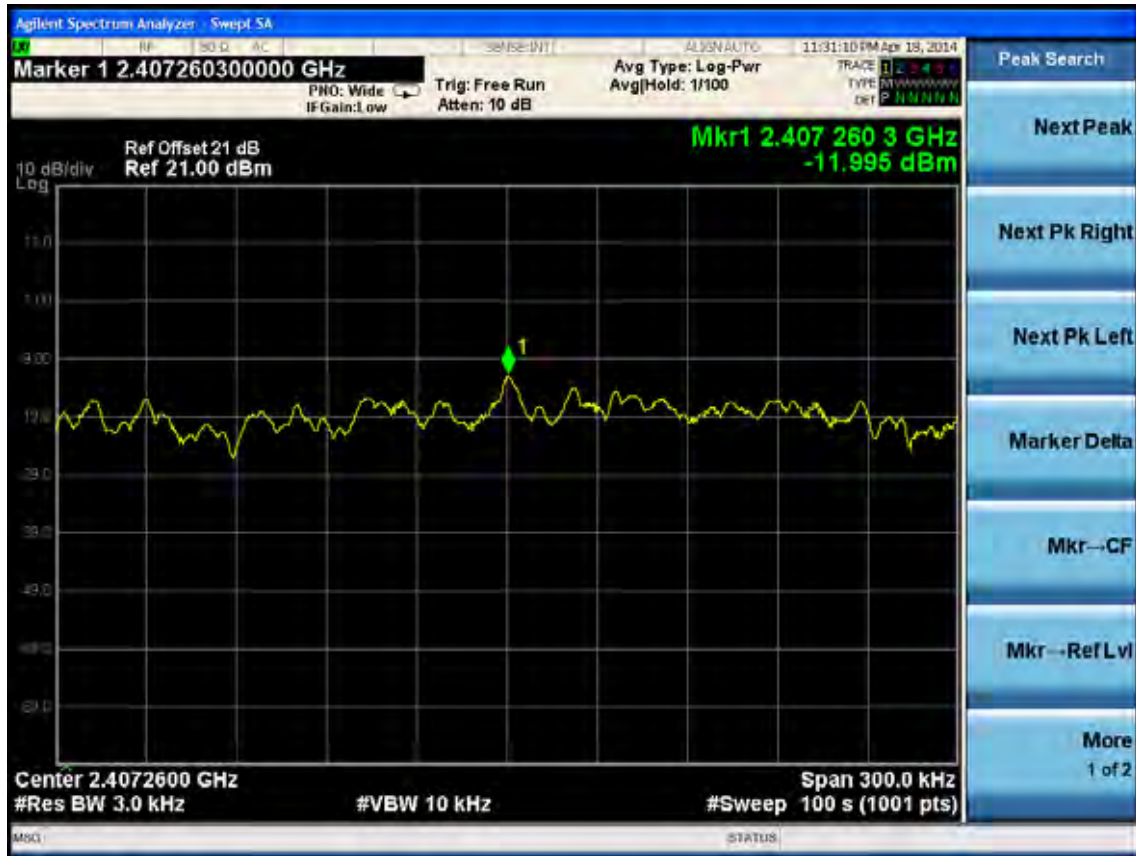

Test CH6: 2437MHz



Test CH11: 2462MHz

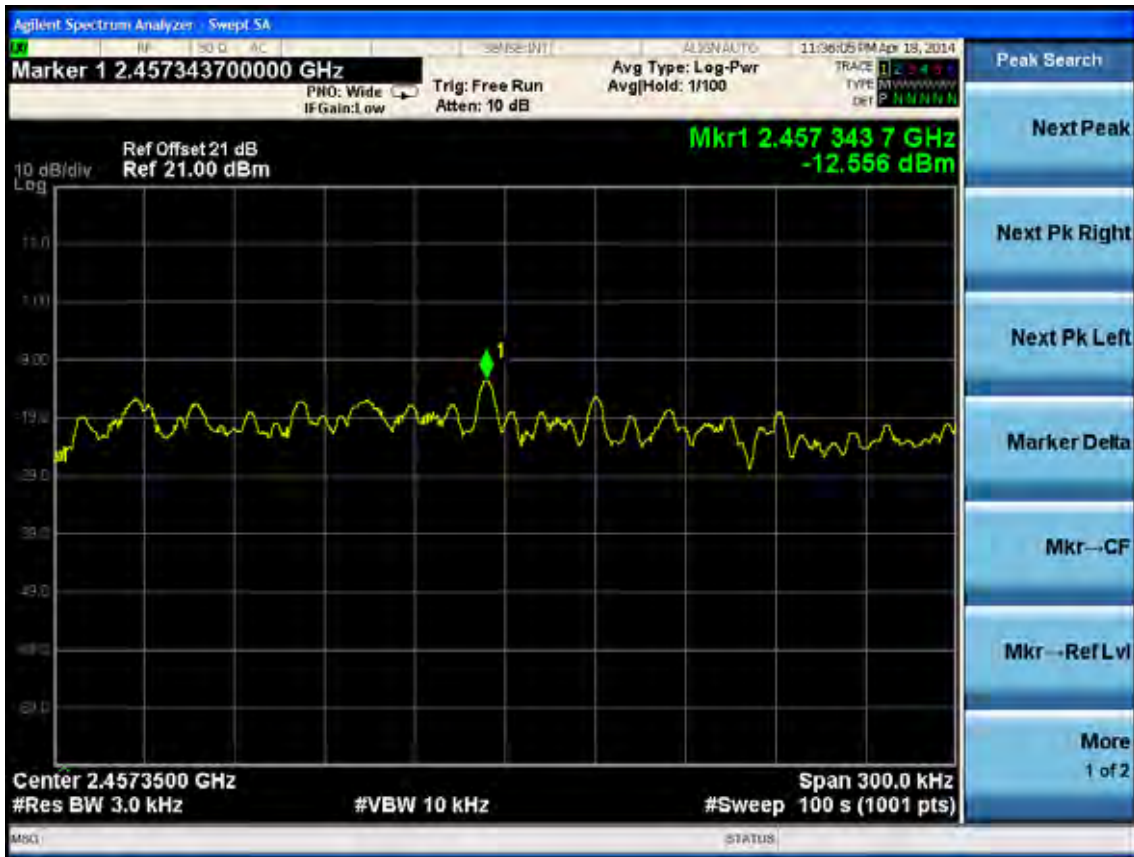

Test Mode: IEEE 802.11n HT40

Test CH1: 2422MHz

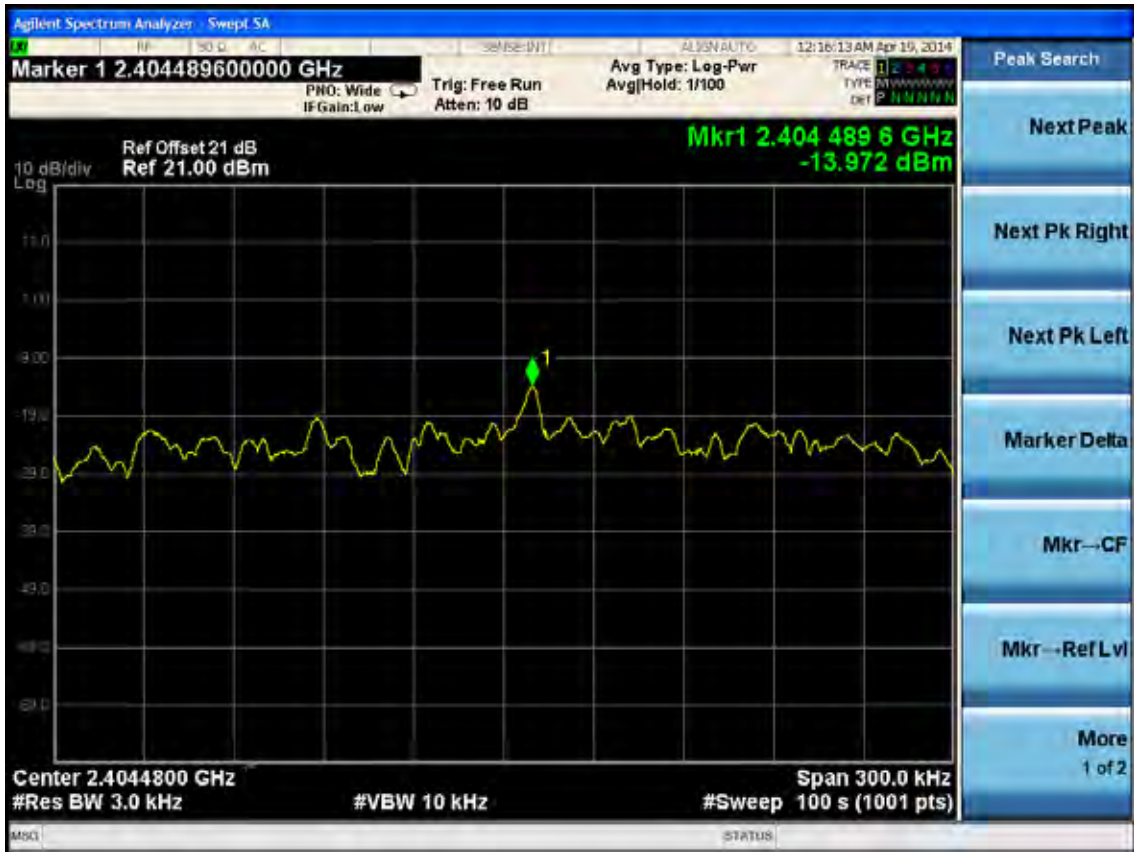

Test CH4: 2437MHz

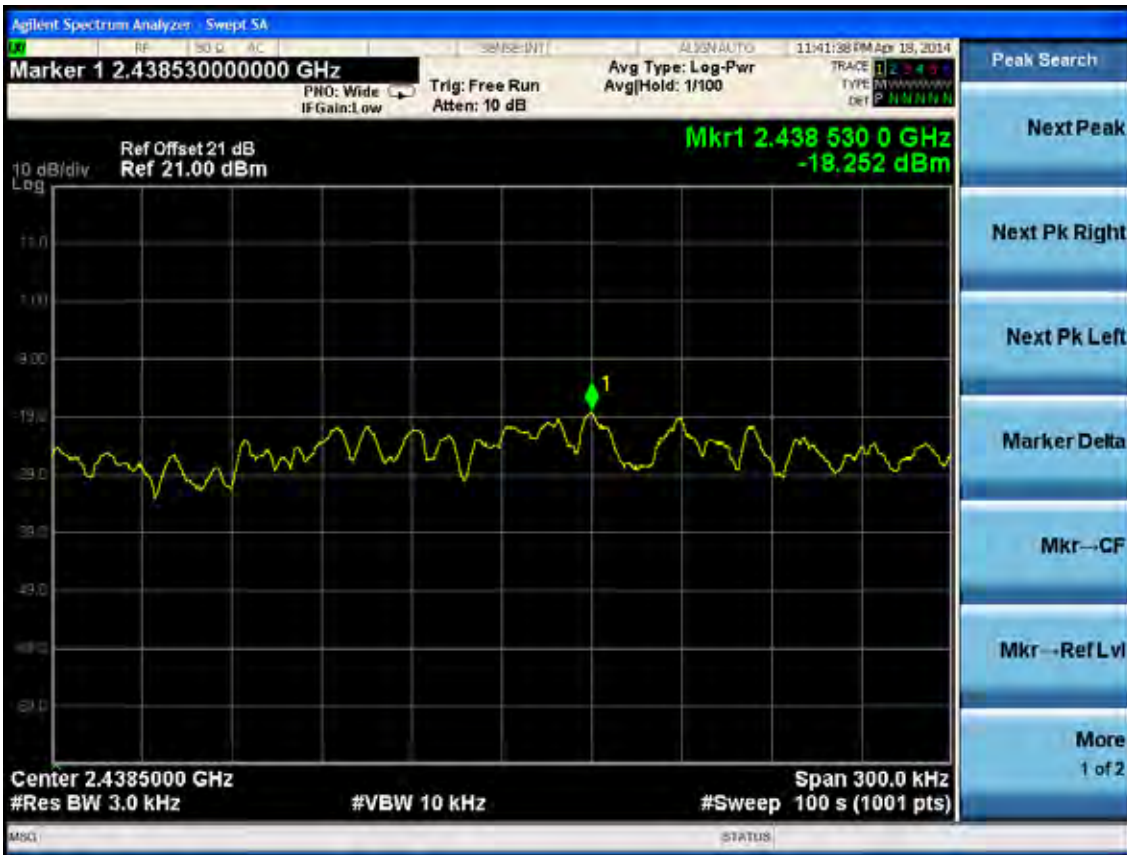

Test CH7: 2452MHz

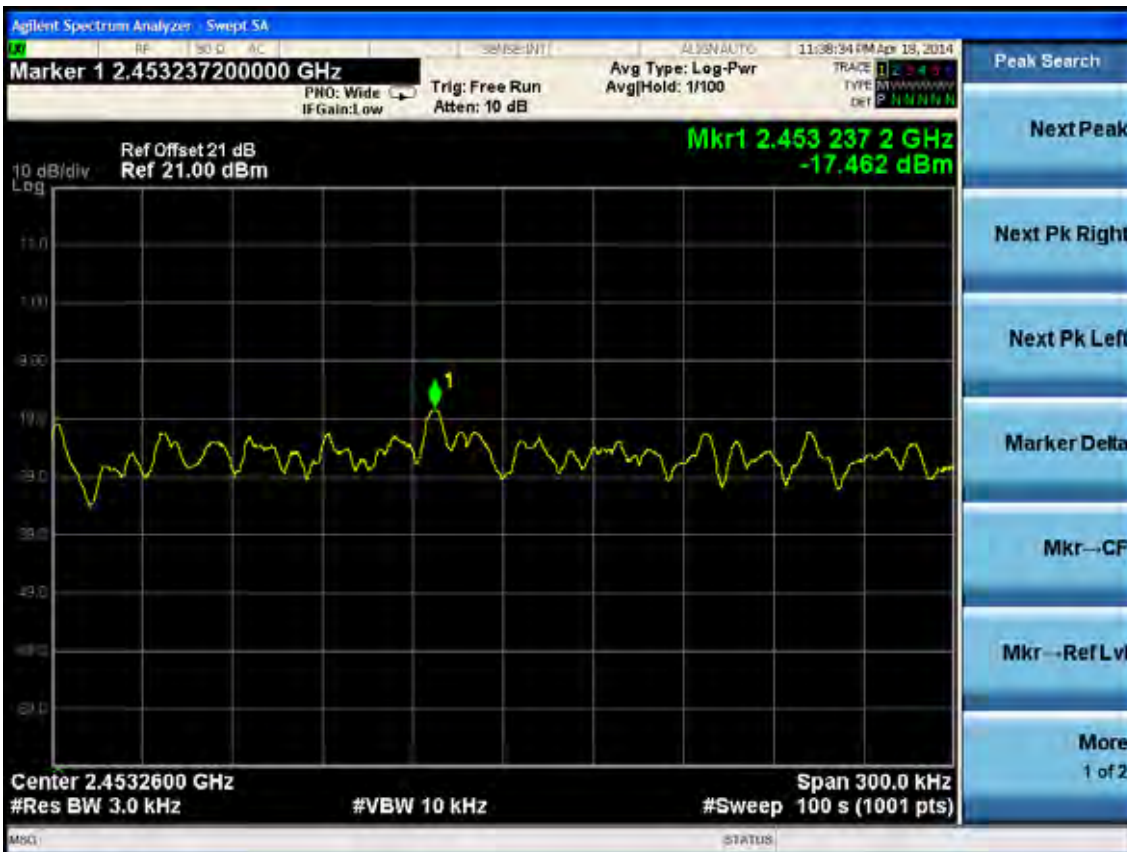

10. ANTENNA REQUIREMENT

10.1. STANDARD APPLICABLE

For intentional device, according to FCC 47 CFR Section 15.203, an intentional radiator shall be designed to ensure that no antenna other than that furnished by the responsible party shall be used with the device. And according to FCC 47 CFR Section 15.247 (b), if transmitting antennas of directional gain greater than 6dBi are used, the power shall be reduced by the amount in dB that the directional gain of the antenna exceeds 6dBi.

10.2. ANTENNA CONNECTED CONSTRUCTION

The antennas used for this product are IFA antenna and that no antenna other than that furnished by the responsible party shall be used with the device, the maximum peak gain of the transmit antenna is only 2.68dBi.

11.DEVIATION TO TEST SPECIFICATIONS

[NONE]