



FCC PART 27, FCC PART 24E  
TEST REPORT

For

**invoxia**

8 ESPLANADE DE LA MANUFACTURE, Issy-Les-Moulineaux, 92130, France

**FCC ID: ZVS-LWT3**

<b>Report Type:</b> Original Report	<b>Product Type:</b> LWT3
<b>Report Number:</b>	RSZ191217001-00B
<b>Report Date:</b>	2019-12-30
<b>Reviewed By:</b>	Simon Wang <i>Simon wang</i> RF Engineer
<b>Prepared By:</b>	Bay Area Compliance Laboratories Corp. (Shenzhen) 6/F., West Wing, Third Phase of Wanli Industrial Building, Shihua Road, Futian Free Trade Zone, Shenzhen, Guangdong, China Tel: +86-755-33320018 Fax: +86-755-33320008 <a href="http://www.baclcorp.com.cn">www.baclcorp.com.cn</a>

**Note:** This report must not be used by the customer to claim product certification, approval, or endorsement by A2LA\* or any agency of the Federal Government. This report may contain data that are not covered by the A2LA accreditation and are marked with an asterisk “★”.

BACL is not responsible for the authenticity of any test data provided by the applicant. Data included from the applicant that may affect test results are marked with an asterisk “\*”. Customer model name, addresses, names, trademarks etc. are not considered data.

This report cannot be reproduced except in full, without prior written approval of the Company. Unless otherwise stated the results shown in this test report refer only to the sample(s) tested. This report is valid only with a valid digital signature. The digital signature may be available only under the Adobe software above version 7.0.

## TABLE OF CONTENTS

<b>GENERAL INFORMATION.....</b>	<b>3</b>
PRODUCT DESCRIPTION FOR EQUIPMENT UNDER TEST (EUT).....	3
OBJECTIVE.....	3
RELATED SUBMITTAL(S)/GRANT(S).....	3
TEST METHODOLOGY.....	3
MEASUREMENT UNCERTAINTY.....	4
TEST FACILITY.....	4
<b>SYSTEM TEST CONFIGURATION.....</b>	<b>5</b>
DESCRIPTION OF TEST CONFIGURATION.....	5
EQUIPMENT MODIFICATIONS.....	6
SUPPORT EQUIPMENT LIST AND DETAILS.....	6
BLOCK DIAGRAM OF TEST SETUP.....	6
<b>SUMMARY OF TEST RESULTS.....</b>	<b>7</b>
<b>TEST EQUIPMENT LIST.....</b>	<b>8</b>
<b>FCC §1.1307(B) &amp; §2.1093 - RF EXPOSURE INFORMATION.....</b>	<b>10</b>
APPLICABLE STANDARD.....	10
TEST RESULT.....	10
<b>FCC §2.1047 - MODULATION CHARACTERISTIC.....</b>	<b>11</b>
<b>FCC § 2.1046, § 24.232 (C); §27.50 (B) (C) (D) (H) - RF OUTPUT POWER.....</b>	<b>12</b>
APPLICABLE STANDARD.....	12
TEST PROCEDURE.....	12
TEST DATA.....	12
<b>FCC §2.1049, §24.238 &amp; §27.53 - OCCUPIED BANDWIDTH.....</b>	<b>21</b>
APPLICABLE STANDARD.....	21
TEST PROCEDURE.....	21
TEST DATA.....	21
<b>FCC §2.1051,§24.238(A); §27.53 - SPURIOUS EMISSIONS AT ANTENNA TERMINALS.....</b>	<b>38</b>
APPLICABLE STANDARD.....	38
TEST PROCEDURE.....	38
TEST DATA.....	38
<b>FCC § 2.1053;§ 24.238 (A); §27.53 SPURIOUS RADIATED EMISSIONS.....</b>	<b>59</b>
APPLICABLE STANDARD.....	59
TEST PROCEDURE.....	59
TEST DATA.....	59
<b>FCC § 24.238 (A); §27.53 (H)(M) - BAND EDGES.....</b>	<b>61</b>
APPLICABLE STANDARD.....	61
TEST PROCEDURE.....	61
TEST DATA.....	61
<b>FCC § 2.1055; § 24.235; §27.54 - FREQUENCY STABILITY.....</b>	<b>86</b>
APPLICABLE STANDARD.....	86
TEST PROCEDURE.....	86
TEST DATA.....	86

## GENERAL INFORMATION

### Product Description for Equipment under Test (EUT)

Product	LWT3
Model	LWT3
Frequency Range	LTE-M Band 2: 1850-1910 MHz LTE-M Band 4: 1710- 1755 MHz LTE-M Band 12: 699-716 MHz LTE-M Band 13: 777-787 MHz
Conducted Average Power	LTE-M Band 2: 23.95dBm LTE-M Band 4: 24.10dBm LTE-M Band 12: 23.15dBm LTE-M Band 13: 23.31dBm
Modulation Technique	QPSK, 16QAM
Antenna Specification	-6 dBi
Voltage Range	DC 3.7V from battery
Date of Test	2019/12/17~2019/12/19
Sample serial number	RSZ191217001-RF-S1
Received date	2019/12/17
Sample/EUT Status	Good condition

### Objective

This test report is prepared on behalf of *invoxia* in accordance with Part 2-Subpart J, Part 24-Subpart E and Subpart 27 of the Federal Communication Commissions rules.

The objective is to determine the compliance of the EUT with FCC rules for output power, modulation characteristic, occupied bandwidth, and spurious emission at antenna terminal, spurious radiated emission, frequency stability and band edge.

### Related Submittal(s)/Grant(s)

FCC Part 15B JAB, Part 15.247 DTS submissions with FCC ID: ZVS-LWT3.

### Test Methodology

All tests and measurements indicated in this document were performed in accordance with the Code of Federal Regulations Title 47 Part 2-Subpart J as well as the following parts:

Part 24 Subpart E - Personal Communication Services  
Part 27 – Miscellaneous wireless communications services

Applicable Standards: TIA/EIA 603-D.

All emissions measurement was performed at Bay Area Compliance Laboratories Corp. (Shenzhen). The radiated testing was performed at an antenna-to-EUT distance of 3 meters.

## Measurement Uncertainty

Parameter		Uncertainty
Occupied Channel Bandwidth		±5%
RF output power, conducted		±0.73dB
Unwanted Emission, conducted		±1.6dB
Radiated Emissions	Below 1GHz	±4.75dB
	Above 1GHz	±4.88dB
Temperature		±1°C
Humidity		±6%
Supply voltages		±0.4%

*Note: The extended uncertainty given in this report is obtained by combining the standard uncertainty times the coverage factor K with the 95% confidence interval. Otherwise required by the applicant or Product Regulations, Decision Rule in this report did not consider the uncertainty.*

## Test Facility

The Test site used by Bay Area Compliance Laboratories Corp. (Shenzhen) to collect test data is located on the 6/F., West Wing, Third Phase of Wanli Industrial Building, Shihua Road, Futian Free Trade Zone, Shenzhen, Guangdong, China.

The test site has been approved by the FCC under the KDB 974614 D01 and is listed in the FCC Public Access Link (PAL) database, FCC Registration No.: 342867, the FCC Designation No.: CN1221.

The test site has been registered with ISED Canada under ISED Canada Registration Number 3062B.

## SYSTEM TEST CONFIGURATION

### Description of Test Configuration

The EUT was configured for testing according to TIA/EIA-603-D.

The final qualification test was performed with the EUT operating at normal mode.

#### Narrowband and resource blocks per cell BW:

Test Item	LTE Band	Bandwidth(MHz)				Modulation		RB setting		Test channel
		5	10	15	20	QPSK	16QAM	NB	TBS Idx	
RF Output Power**	2	√	√	√	√	√	√	0	10	L/M/H
	4	√	√	√	√	√	√	0	10	L/M/H
	12	√	√	×	×	√	√	0	10	L/M/H
	13	√	√	×	×	√	√	0	10	L/M/H*
Peak-to-average ratio	2	√	√	√	√	√	√	0	10	M
	4	√	√	√	√	√	√	0	10	M
	12	√	√	×	×	√	√	0	10	M
	13	√	√	×	×	√	√	0	10	M
Radiated power	2	√	√	√	√	√	√	0	10	M
	4	√	√	√	√	√	√	0	10	M
	12	√	√	×	×	√	√	0	10	M
	13	√	√	×	×	√	√	0	10	M
Occupied Bandwidth	2	√	√	√	√	√	√	0	10	M
	4	√	√	√	√	√	√	0	10	M
	12	√	√	×	×	√	√	0	10	M
	13	√	√	×	×	√	√	0	10	M
Spurious Emissions at Antenna Terminal	2	√	√	√	√	√	√	0	10	M
	4	√	√	√	√	√	√	0	10	M
	12	√	√	×	×	√	√	0	10	M
	13	√	√	×	×	√	√	0	10	M
Field Strength of Spurious Radiation	2	√	√	√	√	√	√	0	10	M
	4	√	√	√	√	√	√	0	10	M
	12	√	√	×	×	√	√	0	10	M
	13	√	√	×	×	√	√	0	10	M
Band Edge	2	√	√	√	√	√	√	0/3@5MHz BW 0/7@10MHz BW 0/11@15MHz BW 0/15@20MHz BW	10	L/H
	4	√	√	√	√	√	√	0/3@5MHz BW 0/7@10MHz BW 0/11@15MHz BW 0/15@20MHz BW	10	L/H
	12	√	√	×	×	√	√	0/3@5MHz BW 0/7@10MHz BW	10	L/H
	13	√	√	×	×	√	√	0/3@5MHz BW 0/7@10MHz BW	10	L/H*
Frequency stability	2	√	√	√	√	√	√	0	10	M
	4	√	√	√	√	√	√	0	10	M
	12	√	√	×	×	√	√	0	10	M
	13	√	√	×	×	√	√	0	10	M

Note \*: only middle channel with LTE band 13 @10MHz bandwidth.

Note \*\*: Both RB1 and RB6 were test for QPSK, Both RB1 and RB5 were test for 16QAM, other item was test RB6 for both QPSK and 16QAM.

**Equipment Modifications**

No modification was made to the EUT.

**Support Equipment List and Details**

Manufacturer	Description	Model	Serial Number
Rohde & Schwarz	Functional radio communication tester	CMW290	101742

**Block Diagram of Test Setup**

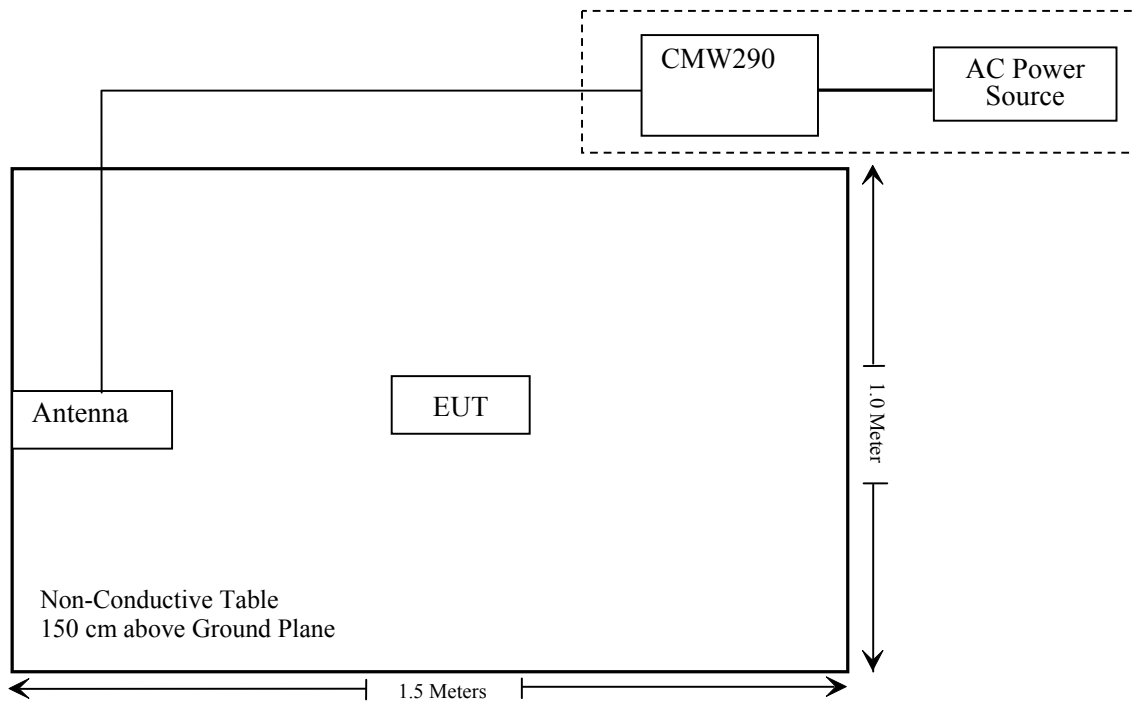

## **SUMMARY OF TEST RESULTS**

<b>FCC Rules</b>	<b>Description of Test</b>	<b>Result</b>
§ 1.1307 , §2.1093	RF Exposure (SAR)	Compliance*
§ 2.1047	Modulation Characteristics	Not Applicable
§2.1046; § 24.232 (c); §27.50 (b) (c) (d) (h)	RF Output Power	Compliance
§ 2.1049;§ 24.238; §27.53	Occupied Bandwidth	Compliance
§ 2.1051; § 24.238 (a); §27.53	Spurious Emissions at Antenna Terminal	Compliance
§ 2.1053; § 24.238 (a); §27.53	Field Strength of Spurious Radiation	Compliance
§ 24.238 (a); §27.53(h) (m)	Band Edge	Compliance
§ 2.1055; § 24.235; §27.54	Frequency stability	Compliance

**Note:**

Compliance\*: Please refer to SAR report released by BACL, report number: RSZ191217001-SA.

**TEST EQUIPMENT LIST**

Manufacturer	Description	Model	Serial Number	Calibration Date	Calibration Due Date
<b>Radiated Emission Test</b>					
Sunol Sciences	Horn Antenna	DRH-118	A052604	2017-12-22	2020-12-21
Rohde & Schwarz	Signal Analyzer	FSEM	845987/005	2019-07-22	2020-07-21
Sunol Sciences	Broadband Antenna	JB1	A040904-1	2017-12-22	2020-12-21
COM-POWER	Pre-amplifier	PA-122	181919	2019-04-20	2020-04-20
Sonoma Instrument	Amplifier	310 N	186238	2019-04-20	2020-04-20
Agilent	Signal Generator	N5183A	MY51040755	2019-12-03	2020-12-03
Rohde & Schwarz	EMI Test Receiver	ESR3	102455	2019-07-09	2020-07-08
COM-POWER	Dipole Antenna	AD-100	41000	NCR	NCR
A.H. System	Horn Antenna	SAS-200/571	135	2018-09-01	2021-08-31
UTiFLEX MICRO-C0AX	RF Cable	UFA147A-2362-100100	MFR64639 231029-003	2019-11-12	2020-11-12
Ducommun Technologies	RF Cable	104PEA	218124002	2019-11-12	2020-11-12
Ducommun Technologies	RF Cable	RG-214	1	2019-11-12	2020-11-12
Ducommun Technologies	RF Cable	RG-214	2	2019-11-12	2020-11-12
Ducommun Technologies	Horn Antenna	ARH-4223-02	1007726-04	2017-12-29	2020-12-28
Ducommun technologies	Horn Antenna	ARH-4223-02	1007726-03	2017-12-29	2020-12-28
Heatsink Required	Amplifier	QLW-18405536-J0	15964001002	2019-11-12	2020-11-12
Unknown	High Pass filter	2.8GHz	Unknown	2019-04-20	2020-04-20
Unknown	High Pass filter	1.3GHz	101120	2019-04-20	2020-04-20



Manufacturer	Description	Model	Serial Number	Calibration Date	Calibration Due Date
<b>RF Conducted Test</b>					
Rohde & Schwarz	Spectrum Analyzer	FSU26	200120	2019-03-02	2020-03-01
ESPEC	Temperature & Humidity Chamber	EL-10KA	9107726	2019-01-05	2020-01-05
Long Wei	DC Power Supply	TPR-6420D	398363	NCR	NCR
Rohde & Schwarz	Functional radio communication tester	CMW290	101742	2019-08-13	2020-08-12
Ducommun Technologies	RF Cable	RG-214	3	Each Time	
Ducommun technologies	RF Cable	UFA210A-1-4724-30050U	MFR64369 223410-001	2019-11-12	2020-11-12
WEINSCHL	3dB Attenuator	6231	666	Each Time	
Unknown	Power Splitter	1620	129	Each Time	

\* Statement of Traceability: Bay Area Compliance Laboratories Corp. (Shenzhen) attests that all calibrations have been performed in accordance to requirements that traceable to National Primary Standards and International System of Units (SI).

---

## **FCC §1.1307(b) & §2.1093 - RF EXPOSURE INFORMATION**

---

### **Applicable Standard**

FCC§1.1310 and §2.1093.

### **Test Result**

Compliance, please refer to the SAR report: RSZ191217001-SA.

---

## **FCC §2.1047 - MODULATION CHARACTERISTIC**

---

According to FCC § 2.1047(d), Part 24E & 27 there is no specific requirement for digital modulation, therefore modulation characteristic is not presented.

**FCC § 2.1046, § 24.232 (c); §27.50 (b) (c) (d) (h) - RF OUTPUT POWER**

**Applicable Standard**

According to FCC §2.1046 and §24.232 (C), mobile and portable stations are limited to 2 watts EIRP and the equipment must employ a means for limiting power to the minimum necessary for successful communications.

The peak-to-average power ratio (PAPR) of the transmitter output power must not exceed 13 dB.

According to §27.50(b), Portable stations (hand-held devices) transmitting in the 746-757 MHz, 776-788 MHz, and 805-806 MHz bands are limited to 3 watts ERP.

According to §27.50(c), Portable stations (hand-held devices) in the 600 MHz uplink band and the 698-746 MHz band, and fixed and mobile stations in the 600 MHz uplink band are limited to 3 watts ERP.

According to §27.50(d), the maximum EIRP must not exceed 1Watts (30dBm) for 1710-1755MHz.

According to §27.50(h), the maximum EIRP must not exceed 2Watts (33dBm) for 2500-2570MHz.

**Test Procedure**

*Conducted method:*

The RF output of the transmitter was connected to the CMW290 through sufficient attenuation.

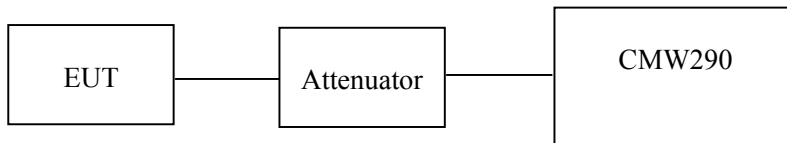

*Radiated method:*

TIA 603-D section 2.2.17

**Test Data**

**Environmental Conditions**

<b>Temperature:</b>	25 °C
<b>Relative Humidity:</b>	59 %
<b>ATM Pressure:</b>	101.0 kPa

*The testing was performed by Zero Yan and Alan He on 2019-12-18.*

**LTE-M Band 2:**

**Maximum Output Power**

Bandwidth (MHz)	Modulation	RB size/ NB Index	Low Channel (dBm)	Middle Channel (dBm)	High Channel (dBm)
5.0	QPSK	RB Size=1, Index=10	23.95	23.74	22.87
		RB Size=6, Index=10	23.92	22.76	22.40
	16QAM	RB Size=1, Index=10	23.74	23.51	22.57
		RB Size=5, Index=10	22.88	22.11	21.75
10.0	QPSK	RB Size=1, Index=10	23.89	23.67	22.89
		RB Size=6, Index=10	23.69	22.85	22.59
	16QAM	RB Size=1, Index=10	23.72	23.53	22.79
		RB Size=5, Index=10	22.92	22.79	22.46
15.0	QPSK	RB Size=1, Index=10	23.89	22.80	22.67
		RB Size=6, Index=10	23.90	22.74	22.51
	16QAM	RB Size=1, Index=10	23.77	22.41	22.61
		RB Size=5, Index=10	23.78	22.55	22.40
20.0	QPSK	RB Size=1, Index=10	22.93	23.75	22.69
		RB Size=6, Index=10	22.86	23.74	22.46
	16QAM	RB Size=1, Index=10	22.88	23.64	22.59
		RB Size=5, Index=10	22.90	23.67	22.62

**Peak-to-average ratio (PAR)**

Bandwidth	Modulation	Middle Channel (dB)	PAR Limit (dB)	Result
5MHz	QPSK	3.40	13	Pass
	16QAM	3.94	13	Pass
10MHz	QPSK	4.16	13	Pass
	16QAM	3.80	13	Pass
15MHz	QPSK	3.03	13	Pass
	16QAM	3.27	13	Pass
20MHz	QPSK	3.05	13	Pass
	16QAM	3.44	13	Pass

**QPSK:**

Frequency (MHz)	Receiver Reading (dBμV)	Turntable Angle Degree	Rx Antenna		Substituted			Absolute Level (dBm)	Limit (dBm)	Margin (dB)
			Height (m)	Polar (H/V)	Level (dBm)	Cable loss (dB)	Antenna Gain (dBd/dBi)			
Middle Channel(1880MHz), 5 MHz Bandwidth										
1880.00	74.65	244	2.3	H	5.0	1.30	9.40	13.10	33	19.9
1880.00	83.73	63	2.3	V	13.8	1.30	9.40	21.90	33	11.1
Middle Channel(1880MHz), 10 MHz Bandwidth										
1880.00	73.12	17	1.8	H	3.4	1.30	9.40	11.50	33	21.5
1880.00	83.00	128	2.4	V	13.1	1.30	9.40	21.20	33	11.8
Middle Channel(1880MHz), 15 MHz Bandwidth										
1880.00	73.29	329	1.5	H	3.6	1.30	9.40	11.70	33	21.3
1880.00	84.40	250	1.1	V	14.5	1.30	9.40	22.60	33	10.4
Middle Channel(1880MHz), 20 MHz Bandwidth										
1880.00	71.47	268	2.3	H	1.8	1.30	9.40	9.90	33	23.1
1880.00	83.52	22	1.9	V	13.6	1.30	9.40	21.70	33	11.3

**16QAM:**

Frequency (MHz)	Receiver Reading (dBμV)	Turntable Angle Degree	Rx Antenna		Substituted			Absolute Level (dBm)	Limit (dBm)	Margin (dB)
			Height (m)	Polar (H/V)	Level (dBm)	Cable loss (dB)	Antenna Gain (dBd/dBi)			
Middle Channel(1880MHz), 5 MHz Bandwidth										
1880.00	71.00	220	1.5	H	1.3	1.30	9.40	9.40	33	23.6
1880.00	82.85	257	1.9	V	13.0	1.30	9.40	21.10	33	11.9
Middle Channel(1880MHz), 10 MHz Bandwidth										
1880.00	73.06	8	1.8	H	3.4	1.30	9.40	11.50	33	21.5
1880.00	82.91	319	1.7	V	13.0	1.30	9.40	21.10	33	11.9
Middle Channel(1880MHz), 15 MHz Bandwidth										
1880.00	71.29	183	1.8	H	1.6	1.30	9.40	9.70	33	23.3
1880.00	83.79	221	2.4	V	13.9	1.30	9.40	22.00	33	11
Middle Channel(1880MHz), 20 MHz Bandwidth										
1880.00	71.42	263	1.6	H	1.7	1.30	9.40	9.80	33	23.2
1880.00	83.83	112	1.5	V	13.9	1.30	9.40	22.00	33	11

**LTE-M Band 4:**

**Maximum Output Power**

Bandwidth (MHz)	Modulation	RB size/ NB Index	Low Channel (dBm)	Middle Channel (dBm)	High Channel (dBm)
5.0	QPSK	RB Size=1, Index=10	24.02	24.10	23.18
		RB Size=6, Index=10	23.17	23.31	22.40
	16QAM	RB Size=1, Index=10	23.95	23.94	24.11
		RB Size=5, Index=10	22.30	22.40	22.45
10.0	QPSK	RB Size=1, Index=10	23.97	23.07	24.08
		RB Size=6, Index=10	23.25	22.31	23.23
	16QAM	RB Size=1, Index=10	24.10	24.09	23.95
		RB Size=5, Index=10	22.40	23.40	23.35
15.0	QPSK	RB Size=1, Index=10	23.15	24.05	24.08
		RB Size=6, Index=10	23.05	24.02	24.06
	16QAM	RB Size=1, Index=10	22.76	23.96	23.99
		RB Size=5, Index=10	22.99	24.05	24.07
20.0	QPSK	RB Size=1, Index=10	23.10	24.05	23.18
		RB Size=6, Index=10	23.09	24.01	23.16
	16QAM	RB Size=1, Index=10	22.75	23.96	23.10
		RB Size=5, Index=10	22.96	24.04	23.06

**Peak-to-average ratio (PAR)**

Bandwidth	Modulation	Middle Channel (dB)	PAR Limit (dB)	Result
5MHz	QPSK	5.45	13	Pass
	16QAM	6.31	13	Pass
10MHz	QPSK	5.80	13	Pass
	16QAM	5.09	13	Pass
15MHz	QPSK	6.22	13	Pass
	16QAM	5.48	13	Pass
20MHz	QPSK	3.98	13	Pass
	16QAM	3.52	13	Pass

**QPSK:**

Frequency (MHz)	Receiver Reading (dBμV)	Turntable Angle Degree	Rx Antenna		Substituted			Absolute Level (dBm)	Limit (dBm)	Margin (dB)
			Height (m)	Polar (H/V)	Level (dBm)	Cable loss (dB)	Antenna Gain (dBd/dBi)			
Middle Channel(1732.5MHz), 5 MHz Bandwidth										
1732.50	80.33	52	1.8	H	7.0	1.30	8.90	14.60	30	15.4
1732.50	87.65	39	1.5	V	14.9	1.30	8.90	22.50	30	7.5
Middle Channel(1732.5MHz), 10 MHz Bandwidth										
1732.50	79.60	11	1.5	H	6.3	1.30	8.90	13.90	30	16.1
1732.50	87.00	74	1.0	V	14.3	1.30	8.90	21.90	30	8.1
Middle Channel(1732.5MHz), 15 MHz Bandwidth										
1732.50	79.91	308	1.8	H	6.6	1.30	8.90	14.20	30	15.8
1732.50	87.36	252	1.8	V	14.6	1.30	8.90	22.20	30	7.8
Middle Channel(1732.5MHz), 20 MHz Bandwidth										
1732.50	82.73	55	1.0	H	9.4	1.30	8.90	17.00	30	13
1732.50	87.14	324	1.4	V	14.4	1.30	8.90	22.00	30	8

**16QAM:**

Frequency (MHz)	Receiver Reading (dBμV)	Turntable Angle Degree	Rx Antenna		Substituted			Absolute Level (dBm)	Limit (dBm)	Margin (dB)
			Height (m)	Polar (H/V)	Level (dBm)	Cable loss (dB)	Antenna Gain (dBd/dBi)			
Middle Channel(1732.5MHz), 5 MHz Bandwidth										
1732.50	80.25	10	1.7	H	6.9	1.30	8.90	14.50	30	15.5
1732.50	86.95	280	2.0	V	14.2	1.30	8.90	21.80	30	8.2
Middle Channel(1732.5MHz), 10 MHz Bandwidth										
1732.50	79.70	218	2.2	H	6.4	1.30	8.90	14.00	30	16
1732.50	86.89	34	2.0	V	14.2	1.30	8.90	21.80	30	8.2
Middle Channel(1732.5MHz), 15 MHz Bandwidth										
1732.50	79.74	223	2.1	H	6.4	1.30	8.90	14.00	30	16
1732.50	87.50	218	2.0	V	14.8	1.30	8.90	22.40	30	7.6
Middle Channel(1732.5MHz), 20 MHz Bandwidth										
1732.50	80.65	182	2.1	H	7.3	1.30	8.90	14.90	30	15.1
1732.50	87.56	338	1.2	V	14.8	1.30	8.90	22.40	30	7.6



**LTE-M Band 12:**

**Maximum Output Power**

Bandwidth (MHz)	Modulation	RB size/ NB Index	Low Channel (dBm)	Middle Channel (dBm)	High Channel (dBm)
5.0	QPSK	RB Size=1, Index=10	22.15	23.08	23.06
		RB Size=6, Index=10	21.45	22.37	22.36
	16QAM	RB Size=1, Index=10	23.15	23.02	23.06
		RB Size=5, Index=10	21.64	21.62	21.59
10.0	QPSK	RB Size=1, Index=10	23.02	23.08	23.12
		RB Size=6, Index=10	22.40	22.36	22.41
	16QAM	RB Size=1, Index=10	23.05	23.01	22.97
		RB Size=5, Index=10	22.49	22.49	22.52

**Peak-to-average ratio (PAR)**

Bandwidth	Modulation	Middle Channel (dB)	PAR Limit (dB)	Result
5MHz	QPSK	4.23	13	Pass
	16QAM	5.37	13	Pass
10MHz	QPSK	4.36	13	Pass
	16QAM	4.29	13	Pass

**QPSK:**

Frequency (MHz)	Receiver Reading (dBμV)	Turntable Angle Degree	Rx Antenna		Substituted			Absolute Level (dBm)	Limit (dBm)	Margin (dB)
			Height (m)	Polar (H/V)	Level (dBm)	Cable loss (dB)	Antenna Gain (dBd/dBi)			
Middle Channel(707.5MHz), 5 MHz Bandwidth										
707.50	81.30	46	2.2	H	11.5	1.56	0.0	9.94	34.77	24.83
707.50	96.15	226	1.8	V	27.8	1.56	0.0	26.24	34.77	8.53
Middle Channel(707.5MHz), 10 MHz Bandwidth										
707.50	80.51	221	1.4	H	10.7	1.56	0.0	9.14	34.77	25.63
707.50	95.97	179	1.1	V	27.6	1.56	0.0	26.04	34.77	8.73

**16QAM:**

Frequency (MHz)	Receiver Reading (dBμV)	Turntable Angle Degree	Rx Antenna		Substituted			Absolute Level (dBm)	Limit (dBm)	Margin (dB)
			Height (m)	Polar (H/V)	Level (dBm)	Cable loss (dB)	Antenna Gain (dBd/dBi)			
Middle Channel(707.5MHz), 5 MHz Bandwidth										
707.50	80.47	273	2.4	H	10.7	1.56	0.0	9.14	34.77	25.63
707.50	96.33	242	2.2	V	28.0	1.56	0.0	26.44	34.77	8.33
Middle Channel(707.5MHz), 10 MHz Bandwidth										
707.50	80.86	96	1.5	H	11.1	1.56	0.0	9.54	34.77	25.23
707.50	96.29	312	1.3	V	28.0	1.56	0.0	26.44	34.77	8.33

**LTE-M Band 13:**

Maximum Output Power

Bandwidth (MHz)	Modulation	RB size/ NB Index	Low Channel (dBm)	Middle Channel (dBm)	High Channel (dBm)
5.0	QPSK	RB Size=1, Index=10	23.31	22.39	22.48
		RB Size=6, Index=10	22.36	21.54	21.57
	16QAM	RB Size=1, Index=10	23.23	23.40	23.51
		RB Size=5, Index=10	21.46	21.52	21.56
10.0	QPSK	RB Size=1, Index=10	/	23.23	/
		RB Size=6, Index=10	/	22.31	/
	16QAM	RB Size=1, Index=10	/	23.19	/
		RB Size=5, Index=10	/	22.50	/

Peak-to-average ratio (PAR)

Bandwidth	Modulation	Middle Channel (dB)	PAR Limit (dB)	Result
5MHz	QPSK	6.32	13	Pass
	16QAM	6.03	13	Pass
10MHz	QPSK	5.39	13	Pass
	16QAM	6.22	13	Pass

**QPSK:**

Frequency (MHz)	Receiver Reading (dBμV)	Turntable Angle Degree	Rx Antenna		Substituted			Absolute Level (dBm)	Limit (dBm)	Margin (dB)
			Height (m)	Polar (H/V)	Level (dBm)	Cable loss (dB)	Antenna Gain (dBd/dBi)			
Middle Channel(782MHz), 5 MHz Bandwidth										
782.00	80.33	120	2.1	H	13.1	1.68	0.0	11.42	34.77	23.35
782.00	94.10	224	1.5	V	26.6	1.68	0.0	24.92	34.77	9.85
Middle Channel(782MHz), 10 MHz Bandwidth										
782.00	80.72	69	1.1	H	13.5	1.68	0.0	11.82	34.77	22.95
782.00	95.31	281	1.6	V	27.8	1.68	0.0	26.12	34.77	8.65

**16QAM:**

Frequency (MHz)	Receiver Reading (dBμV)	Turntable Angle Degree	Rx Antenna		Substituted			Absolute Level (dBm)	Limit (dBm)	Margin (dB)
			Height (m)	Polar (H/V)	Level (dBm)	Cable loss (dB)	Antenna Gain (dBd/dBi)			
Middle Channel(782MHz), 5 MHz Bandwidth										
782.00	80.12	14	1.0	H	12.9	1.68	0.0	11.22	34.77	23.55
782.00	94.58	146	1.2	V	27.1	1.68	0.0	25.42	34.77	9.35
Middle Channel(782MHz), 10 MHz Bandwidth										
782.00	80.44	98	2.2	H	13.2	1.68	0.0	11.52	34.77	23.25
782.00	94.43	235	1.7	V	27.0	1.68	0.0	25.32	34.77	9.45

**Note:**

All above data were tested with no amplifier.  
 Absolute Level = Substituted Level - Cable loss + Antenna Gain  
 Margin = Limit- Absolute Level  
 dBd is for the ERP, dBi is for EIRP.

**FCC §2.1049, §24.238 & §27.53 - OCCUPIED BANDWIDTH**

**Applicable Standard**

FCC 47 §2.1049, §24.238 and §27.53.

**Test Procedure**

The RF output of the transmitter was connected to the simulator and the spectrum analyzer through sufficient attenuation.

The resolution bandwidth of the spectrum analyzer was set at 1% to 5% of the anticipated emission bandwidth and the 26 dB & 99% bandwidth was recorded.

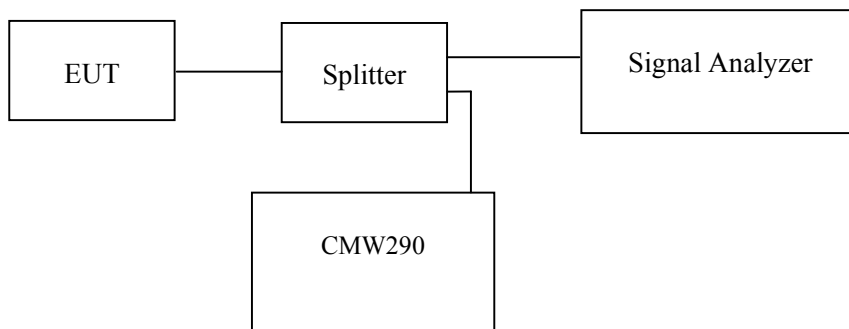

**Test Data**

**Environmental Conditions**

<b>Temperature:</b>	25 °C
<b>Relative Humidity:</b>	52 %
<b>ATM Pressure:</b>	101.0 kPa

*The testing was performed by Gavin Guo on 2019-12-19.*

*EUT operation mode: Transmitting*

*Test Result: Compliance. Please refer to the following tables and plots.*

**LTE-M Band 2: (Middle Channel)**

<b>Bandwidth (MHz)</b>	<b>Modulation</b>	<b>99% Occupied Bandwidth (MHz)</b>	<b>26 dB Emission Bandwidth (MHz)</b>
5.0	QPSK	1.146	1.514
	16QAM	1.154	1.514
10.0	QPSK	1.138	1.520
	16QAM	1.130	1.496
15.0	QPSK	1.162	1.522
	16QAM	1.154	1.514
20.0	QPSK	1.178	1.514
	16QAM	1.178	1.490

**QPSK (5.0 MHz) - 26 dB Bandwidth & 99% Occupied Bandwidth, Middle channel**

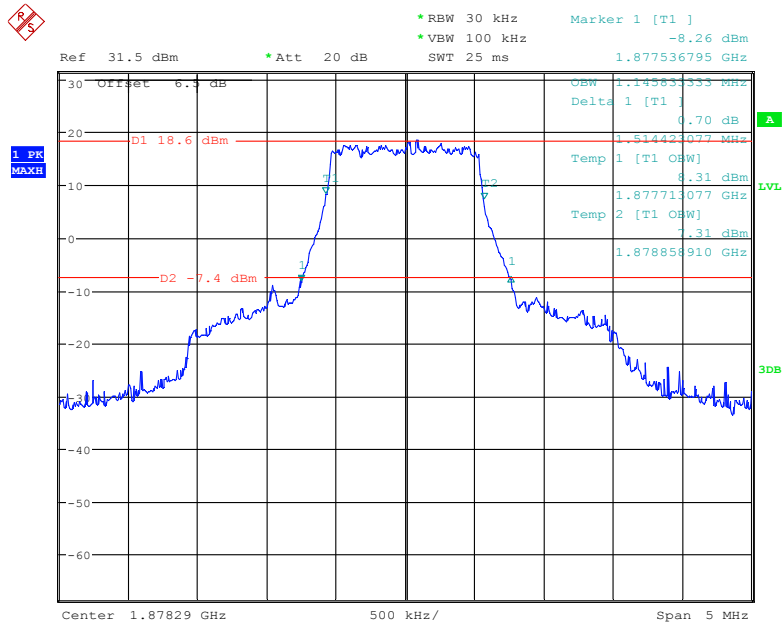

Date: 19.DEC.2019 16:46:20

**16-QAM (5.0 MHz) - 26 dB Bandwidth & 99% Occupied Bandwidth, Middle channel**

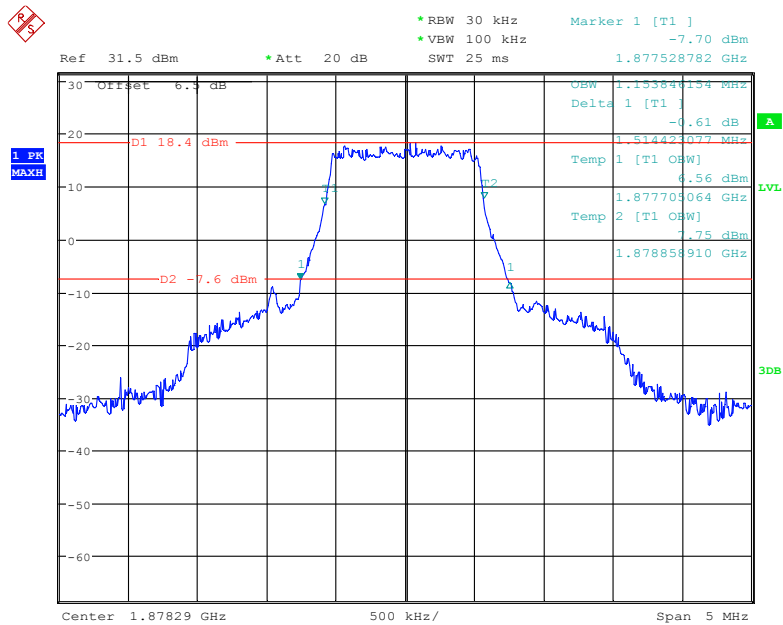

Date: 19.DEC.2019 16:47:08

**QPSK (10.0 MHz) - 26 dB Bandwidth & 99% Occupied Bandwidth, Middle channel**

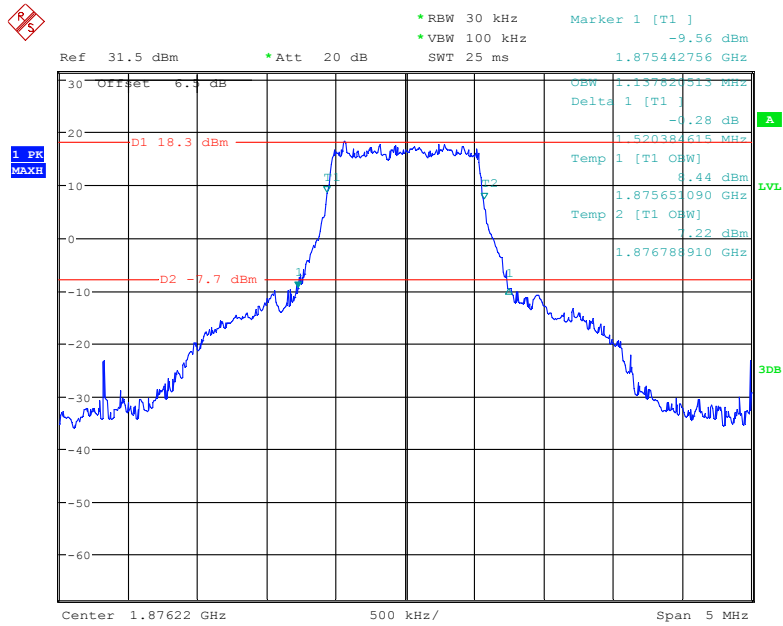

Date: 19.DEC.2019 16:51:05

**16-QAM (10.0 MHz) - 26 dB Bandwidth & 99% Occupied Bandwidth, Middle channel**

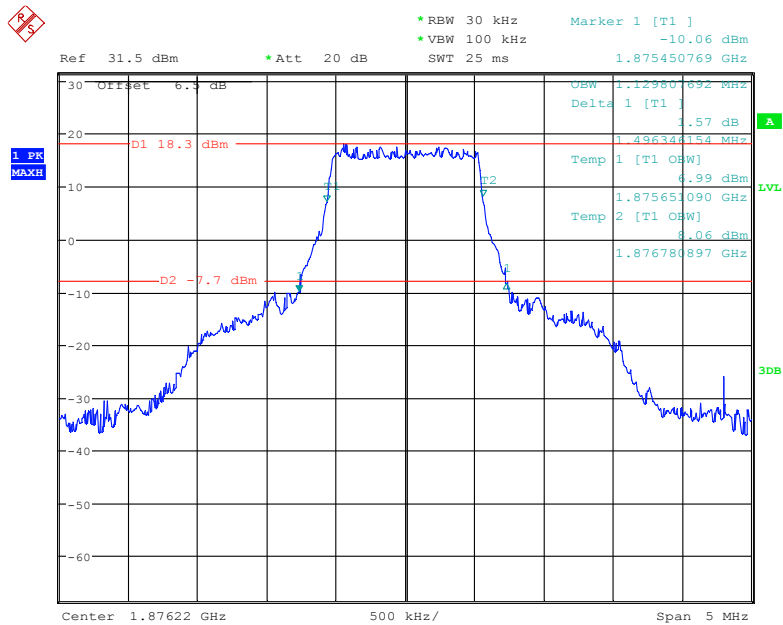

Date: 19.DEC.2019 16:50:06



**QPSK (15.0 MHz) - 26 dB Bandwidth & 99% Occupied Bandwidth, Middle channel**

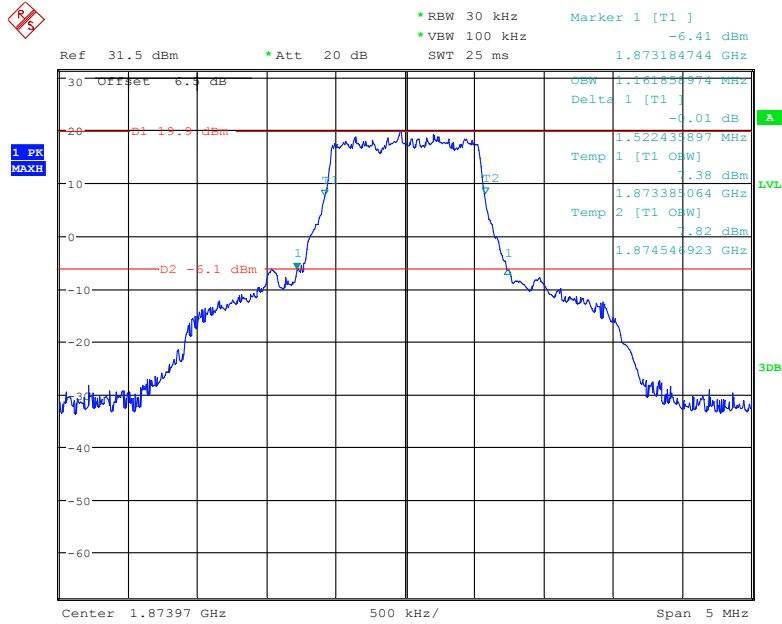

Date: 19.DEC.2019 16:54:57

**16-QAM (15.0 MHz) - 26 dB Bandwidth & 99% Occupied Bandwidth, Middle channel**

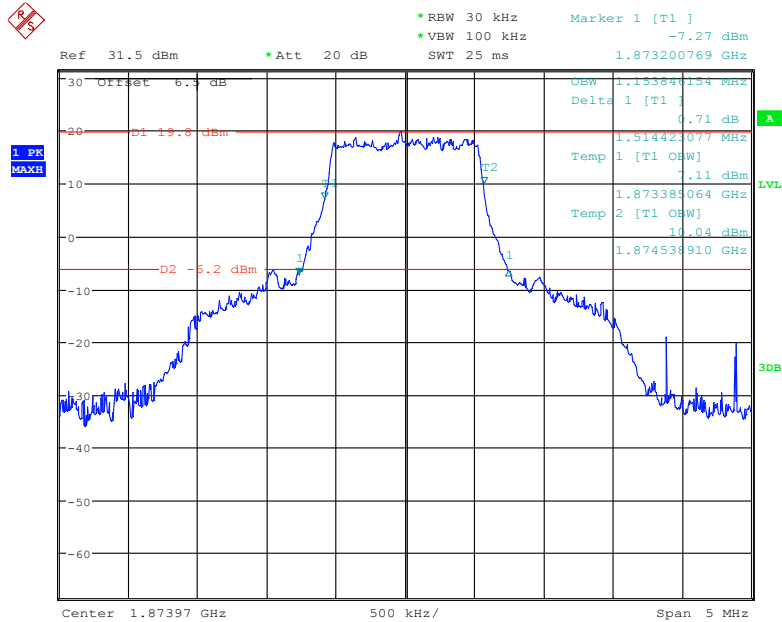

Date: 19.DEC.2019 16:56:15

**QPSK (20.0 MHz) - 26 dB Bandwidth & 99% Occupied Bandwidth, Middle channel**

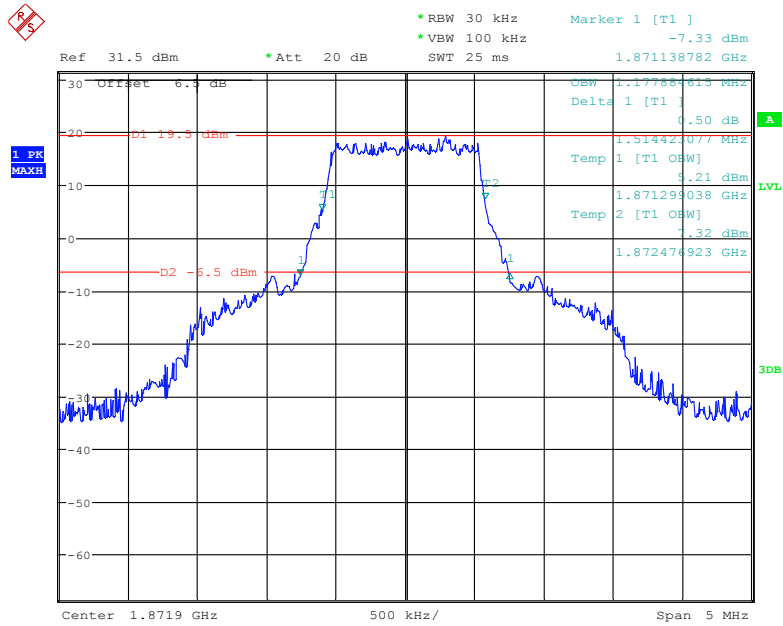

Date: 19.DEC.2019 16:59:34

**16-QAM (20.0 MHz) - 26 dB Bandwidth & 99% Occupied Bandwidth, Middle channel**

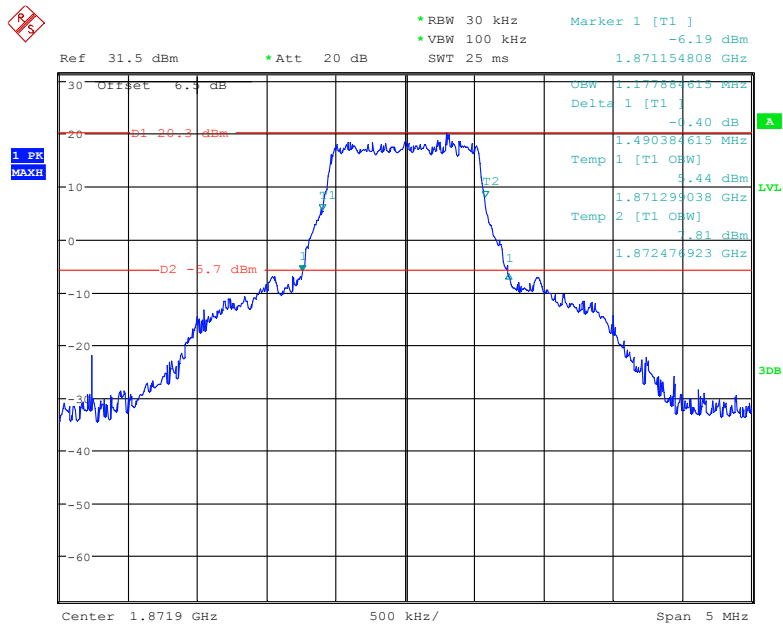

Date: 19.DEC.2019 16:58:51

**LTE-M Band 4: (Middle Channel)**

<b>Bandwidth (MHz)</b>	<b>Modulation</b>	<b>99% Occupied Bandwidth (MHz)</b>	<b>26 dB Emission Bandwidth (MHz)</b>
5.0	QPSK	1.154	1.498
	16QAM	1.154	1.490
10.0	QPSK	1.146	1.554
	16QAM	1.138	1.522
15.0	QPSK	1.130	1.480
	16QAM	1.130	1.488
20.0	QPSK	1.154	1.498
	16QAM	1.154	1.490

**QPSK (5.0 MHz) - 26 dB Bandwidth & 99% Occupied Bandwidth, Middle channel**

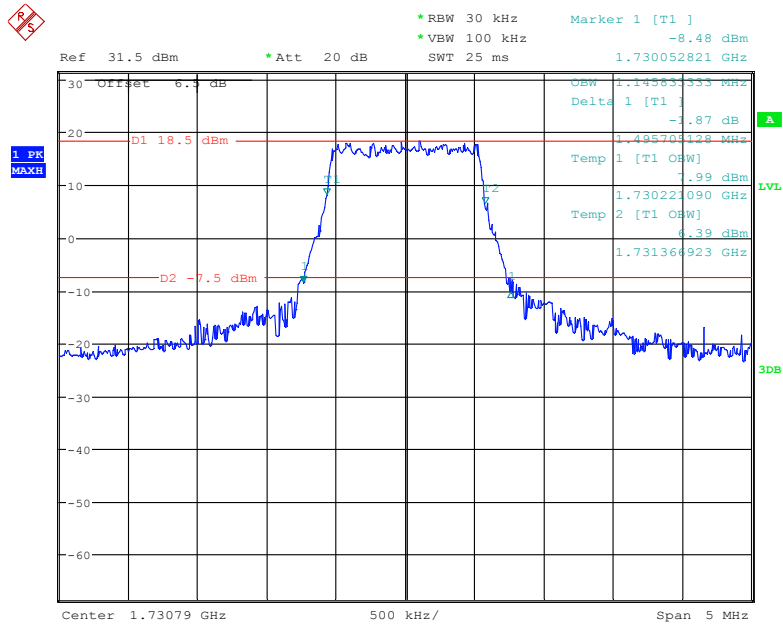

Date: 19.DEC.2019 17:10:39

**16-QAM (5.0 MHz) - 26 dB Bandwidth & 99% Occupied Bandwidth, Middle channel**

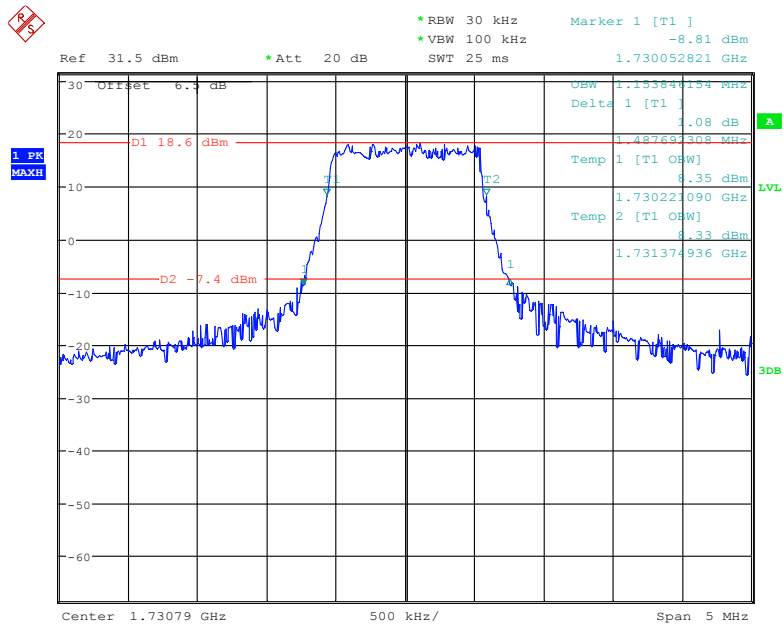

Date: 19.DEC.2019 17:11:34

**QPSK (10.0 MHz) - 26 dB Bandwidth & 99% Occupied Bandwidth, Middle channel**

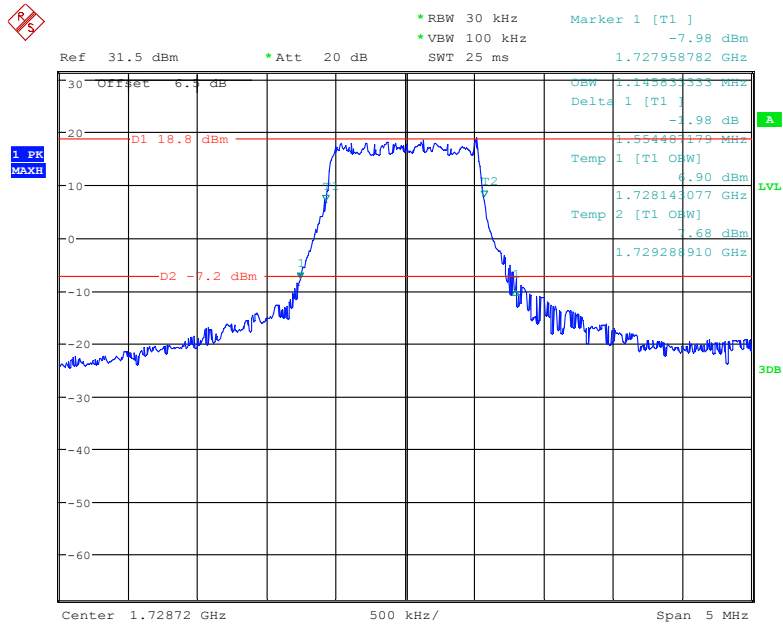

Date: 19.DEC.2019 17:08:34

**16-QAM (10.0 MHz) - 26 dB Bandwidth & 99% Occupied Bandwidth, Middle channel**

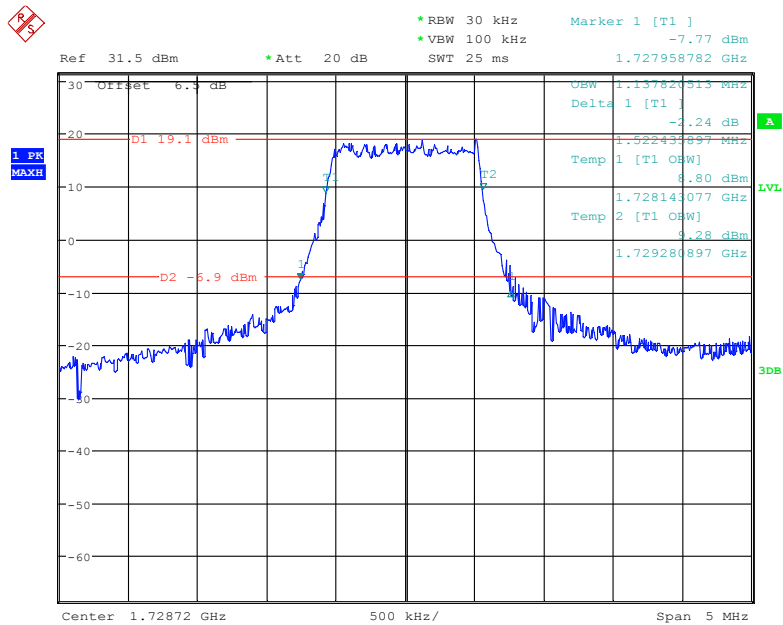

Date: 19.DEC.2019 17:07:22

**QPSK (15.0 MHz) - 26 dB Bandwidth & 99% Occupied Bandwidth, Middle channel**

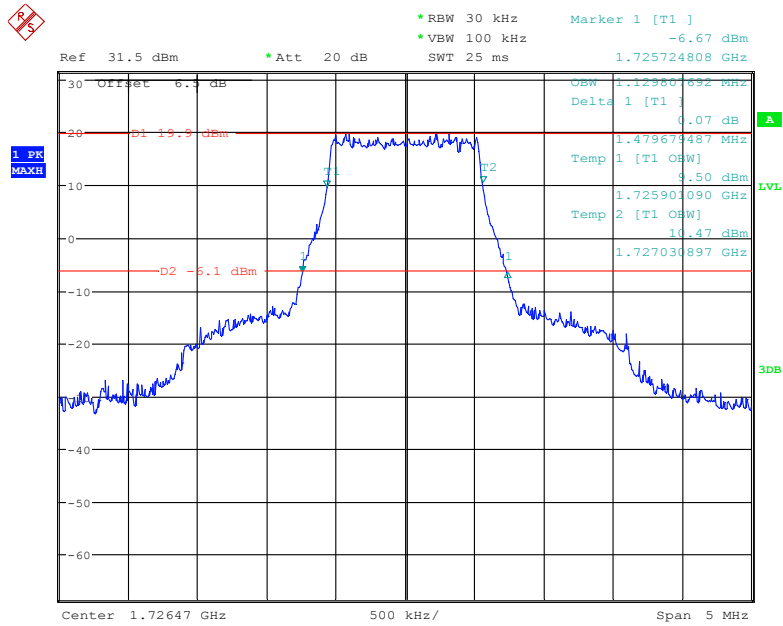

Date: 19.DEC.2019 17:04:50

**16-QAM (15.0 MHz) - 26 dB Bandwidth & 99% Occupied Bandwidth, Middle channel**

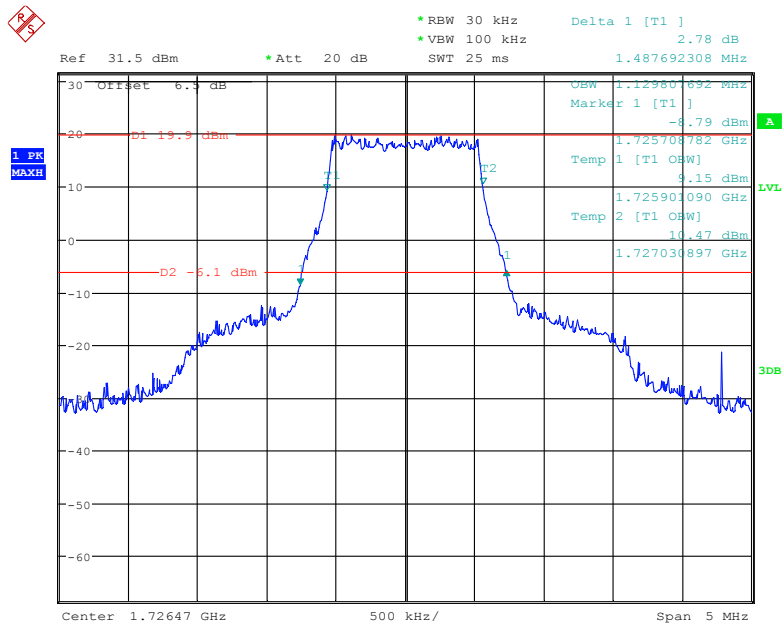

Date: 19.DEC.2019 17:05:58

**QPSK (20.0 MHz) - 26 dB Bandwidth & 99% Occupied Bandwidth, Middle channel**

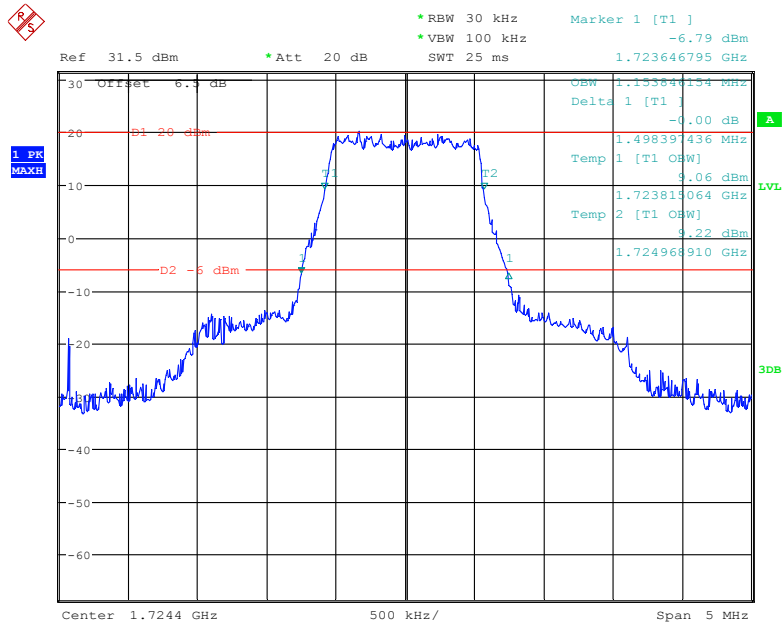

Date: 19.DEC.2019 17:03:10

**16-QAM (20.0 MHz) - 26 dB Bandwidth & 99% Occupied Bandwidth, Middle channel**

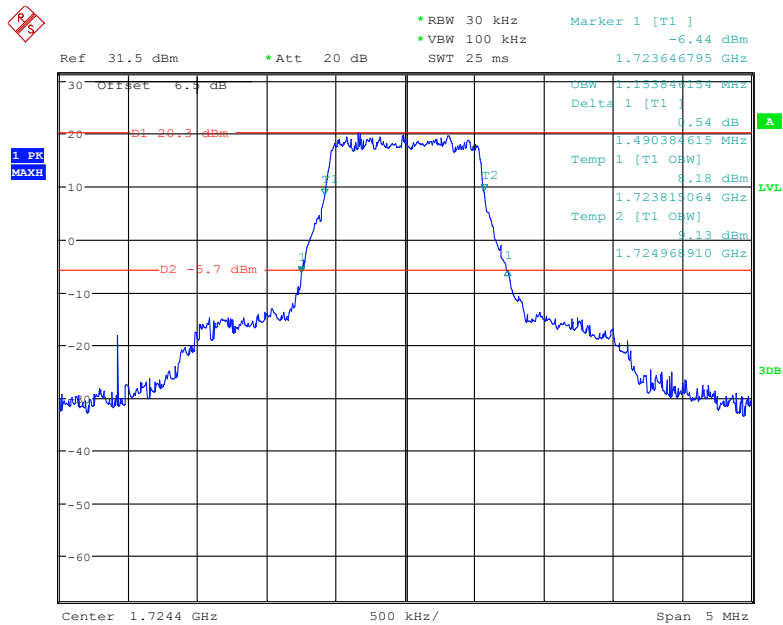

Date: 19.DEC.2019 17:02:29

**LTE-M Band 12: (Middle Channel)**

<b>Bandwidth (MHz)</b>	<b>Modulation</b>	<b>99% Occupied Bandwidth (MHz)</b>	<b>26 dB Emission Bandwidth (MHz)</b>
5.0	QPSK	1.154	1.482
	16QAM	1.154	1.498
10.0	QPSK	1.130	1.501
	16QAM	1.130	1.493



**QPSK (5.0 MHz) - 26 dB Bandwidth & 99% Occupied Bandwidth, Middle channel**

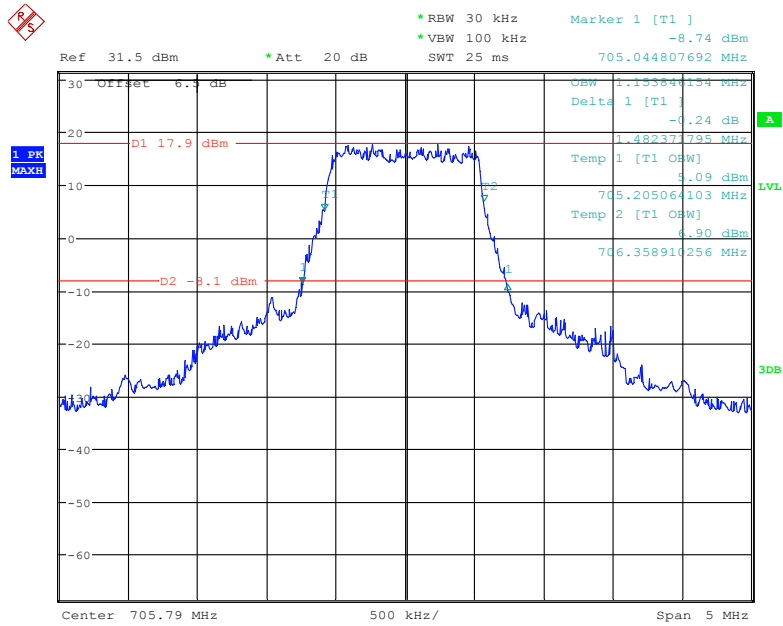

Date: 19.DEC.2019 17:14:50

**16-QAM (5.0 MHz) - 26 dB Bandwidth & 99% Occupied Bandwidth, Middle channel**

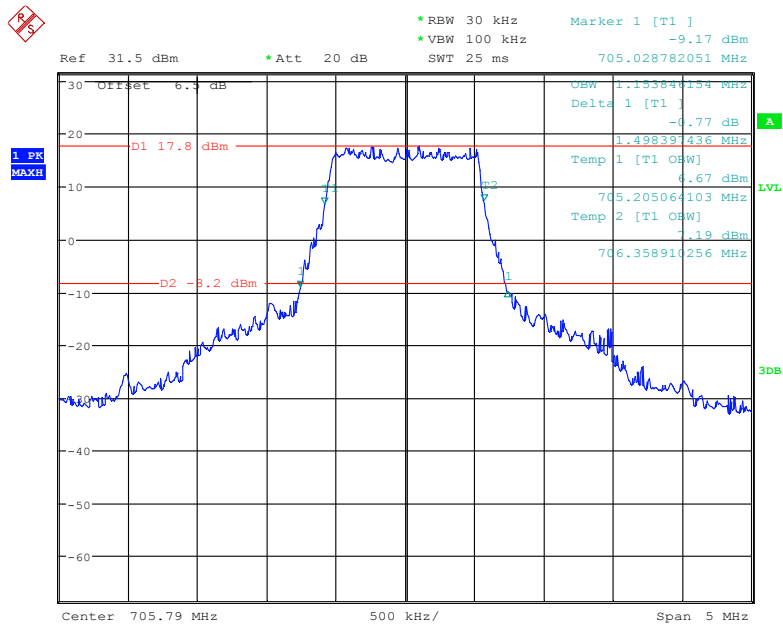

Date: 19.DEC.2019 17:14:02

**QPSK (10.0 MHz) - 26 dB Bandwidth & 99% Occupied Bandwidth, Middle channel**

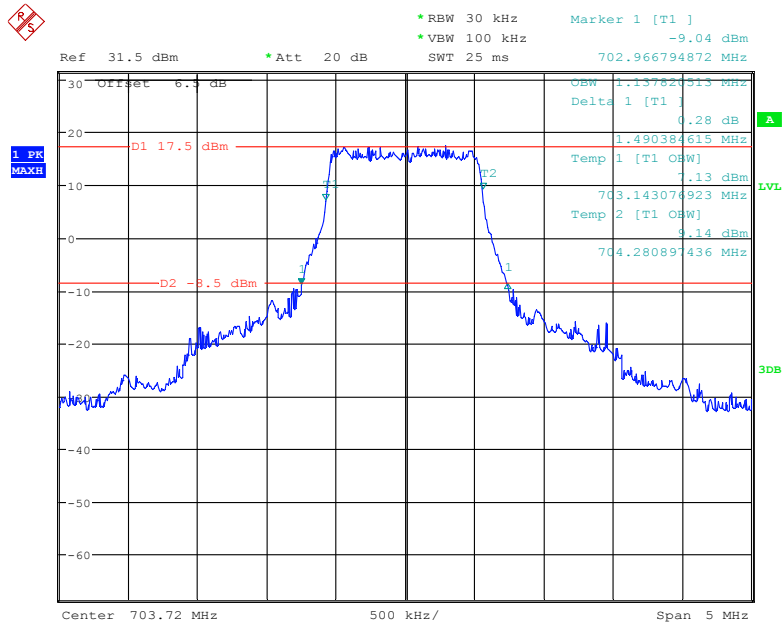

Date: 19.DEC.2019 17:16:28

**16-QAM (10.0 MHz) - 26 dB Bandwidth & 99% Occupied Bandwidth, Middle channel**

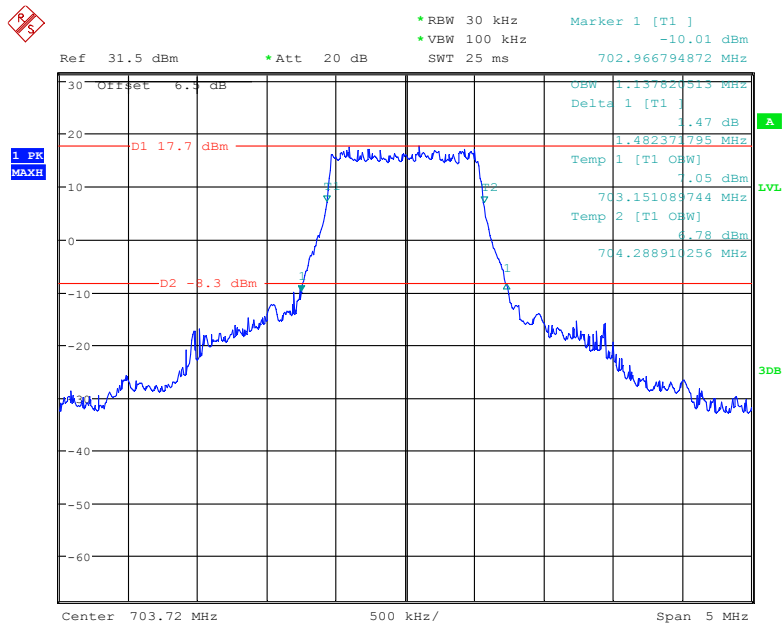

Date: 19.DEC.2019 17:17:28

**LTE-M Band 13: (Middle Channel)**

<b>Bandwidth (MHz)</b>	<b>Modulation</b>	<b>99% Occupied Bandwidth (MHz)</b>	<b>26 dB Emission Bandwidth (MHz)</b>
5.0	QPSK	1.138	1.474
	16QAM	1.138	1.490
10.0	QPSK	1.130	1.501
	16QAM	1.130	1.493

**QPSK (5.0 MHz) - 26 dB Bandwidth & 99% Occupied Bandwidth, Middle channel**

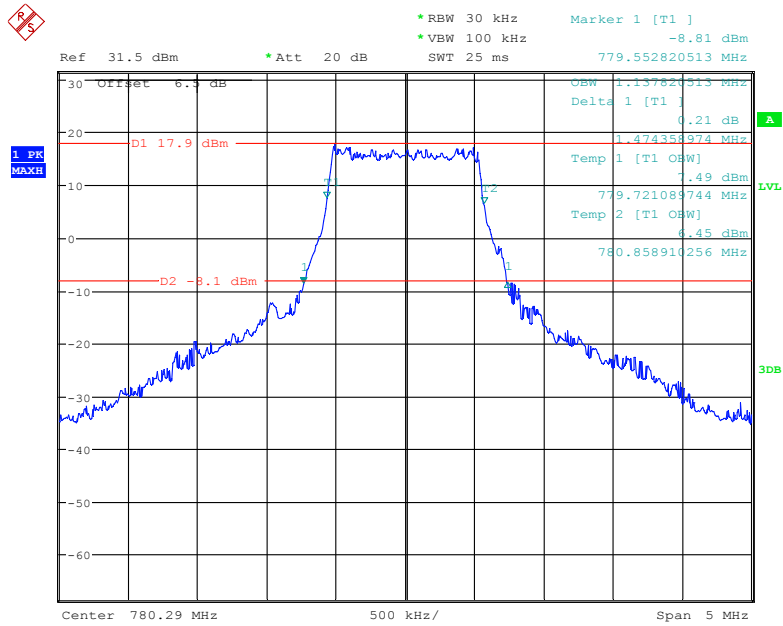

Date: 19.DEC.2019 17:21:38

**16-QAM (5.0 MHz) - 26 dB Bandwidth & 99% Occupied Bandwidth, Middle channel**

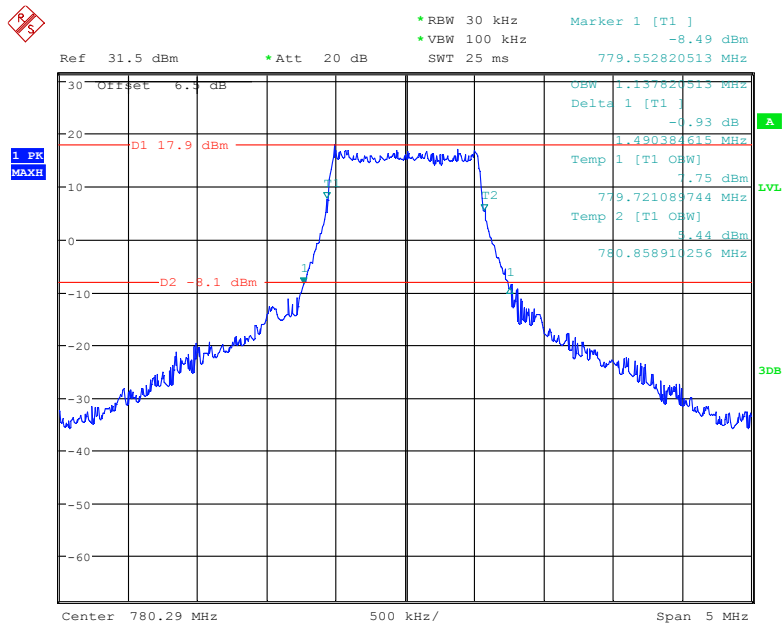

Date: 19.DEC.2019 17:23:22

**QPSK (10.0 MHz) - 26 dB Bandwidth & 99% Occupied Bandwidth, Middle channel**

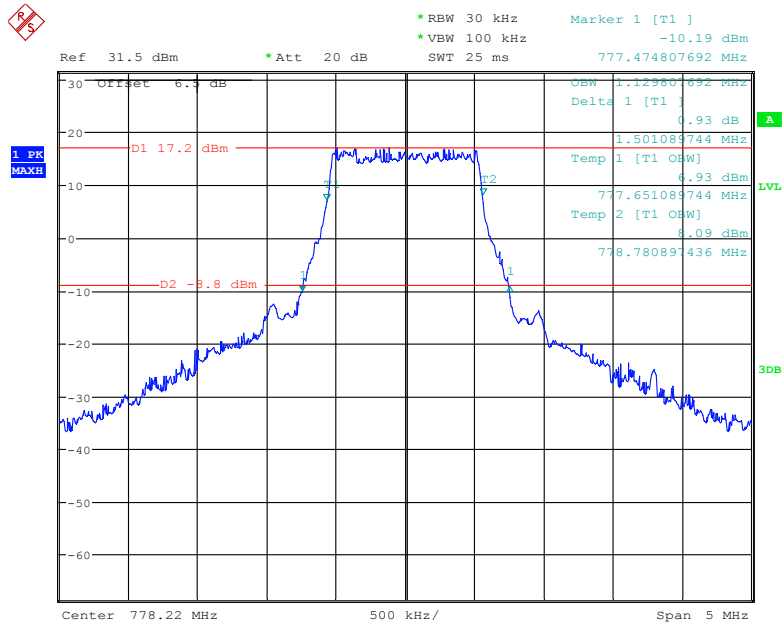

Date: 19.DEC.2019 17:20:11

**16-QAM (10.0 MHz) - 26 dB Bandwidth & 99% Occupied Bandwidth, Middle channel**

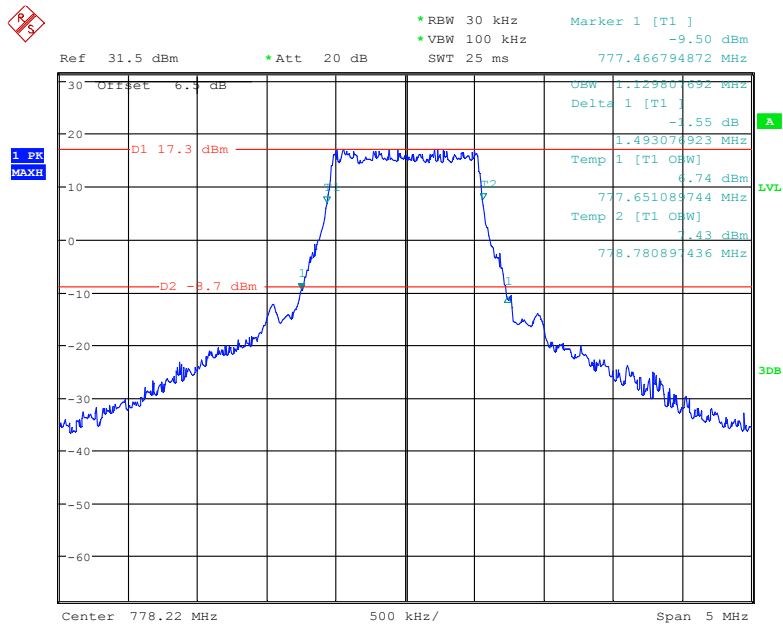

Date: 19.DEC.2019 17:19:19

**FCC §2.1051,§24.238(a); §27.53 - SPURIOUS EMISSIONS AT ANTENNA TERMINALS**

**Applicable Standard**

FCC §2.1051, §24.238(a) and §27.53.

The spectrum was to be investigated to the tenth harmonics of the highest fundamental frequency as specified in § 2.1051.

**Test Procedure**

The RF output of the transceiver was connected to a spectrum analyzer and simulator through appropriate attenuation. The resolution bandwidth of the spectrum analyzer was set at 1MHz. Sufficient scans were taken to show any out of band emissions up to 10<sup>th</sup> harmonic.

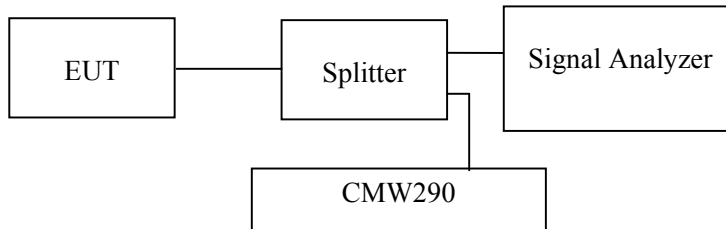

**Test Data**

**Environmental Conditions**

<b>Temperature:</b>	25 °C
<b>Relative Humidity:</b>	52 %
<b>ATM Pressure:</b>	101.0 kPa

*The testing was performed by Gavin Guo on 2019-12-17.*

*Test result: Compliance.*

*EUT operation mode: transmitting*

*Please refer to the following plots.*

**LTE-M Band 2:**

**30 MHz - 1 GHz (5.0 MHz, Middle Channel)**

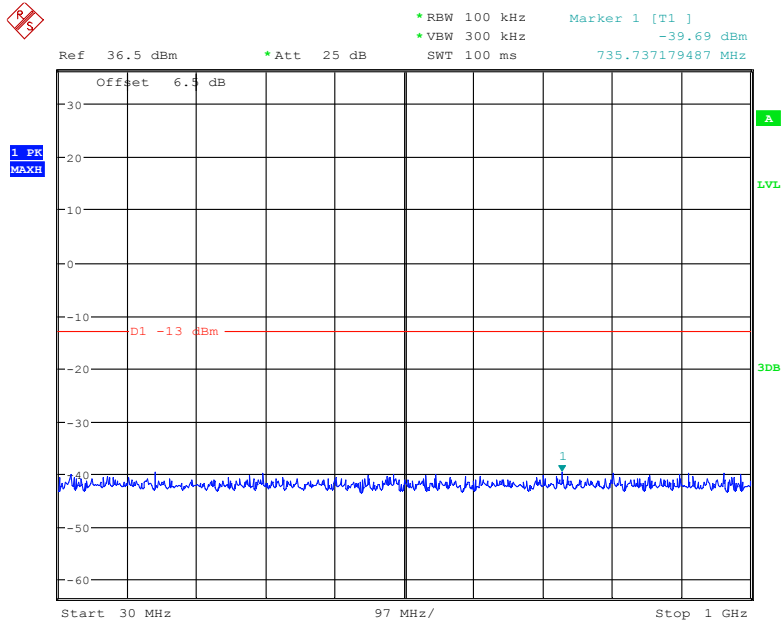

Date: 17.DEC.2019 13:15:35

**1 GHz - 3 GHz (5.0 MHz, Middle Channel)**

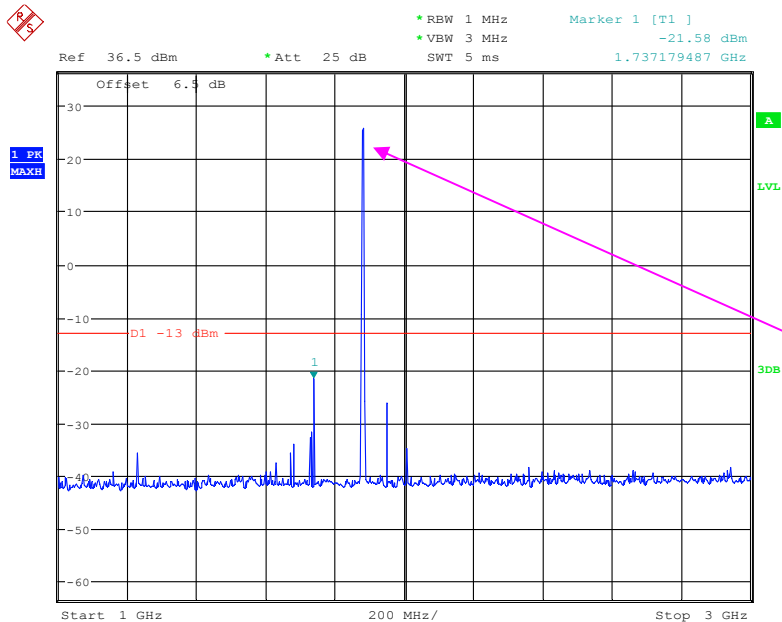

Date: 17.DEC.2019 13:14:45

### 3 GHz – 20 GHz (5.0 MHz, Middle Channel)

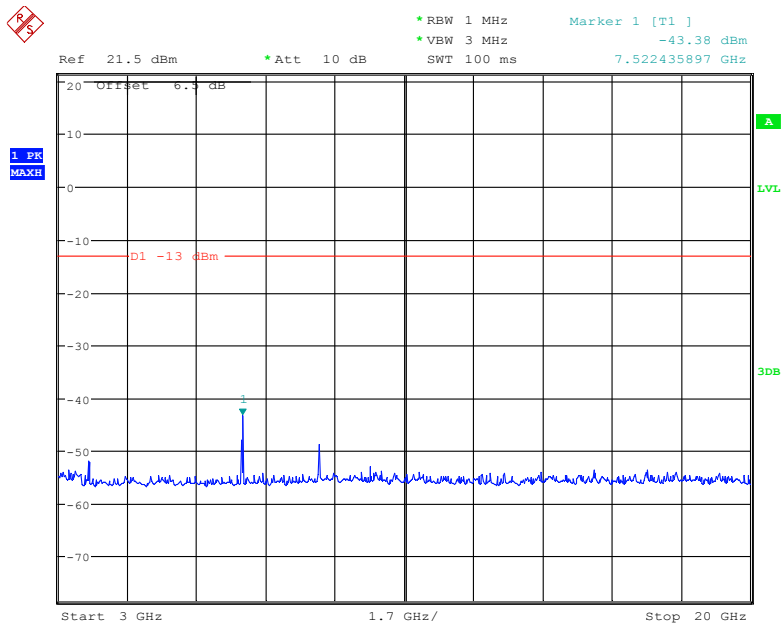

Date: 17.DEC.2019 13:13:13

### 30 MHz - 1 GHz (10.0 MHz, Middle Channel)

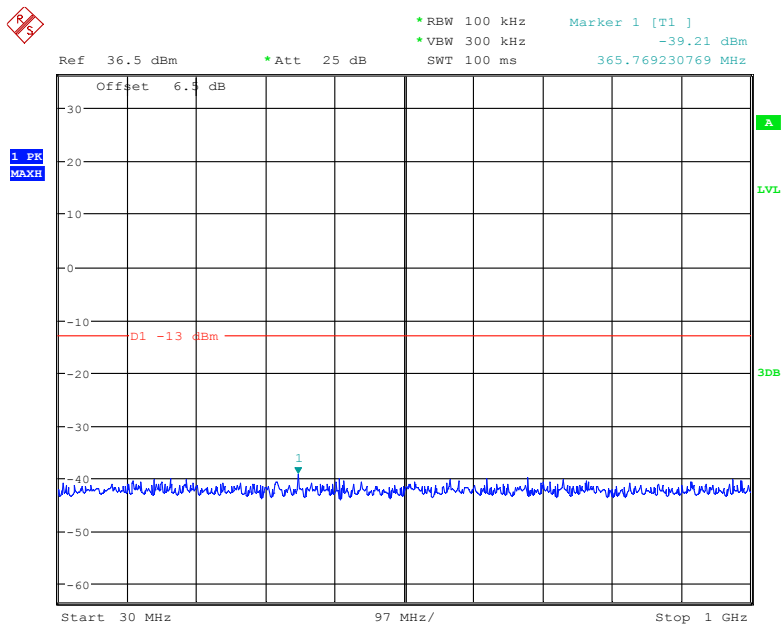

Date: 17.DEC.2019 13:16:04



**1 GHz – 3 GHz (10.0 MHz, Middle Channel)**

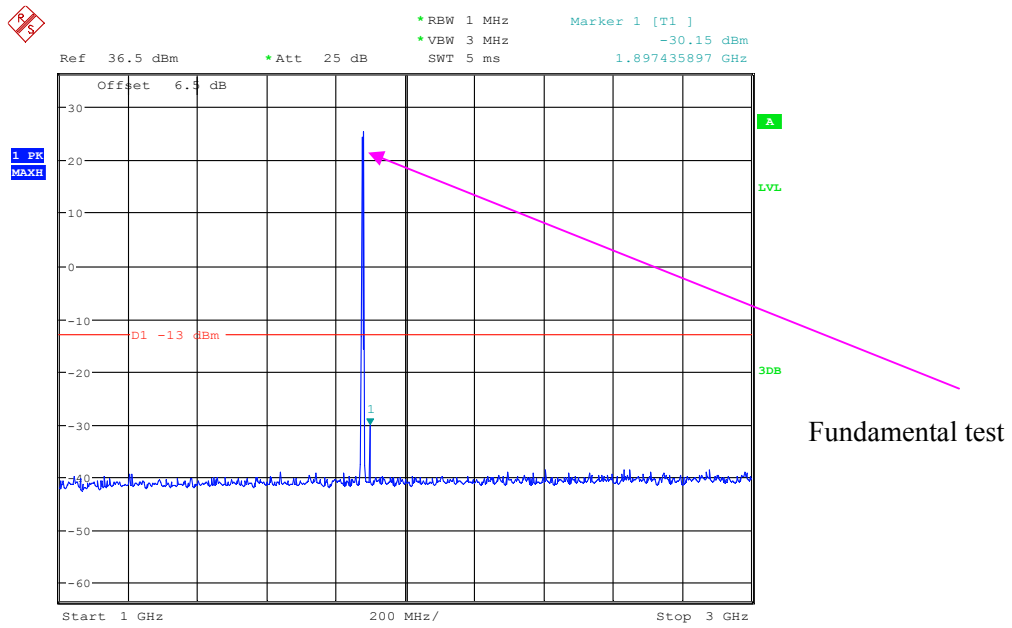

Date: 17.DEC.2019 13:28:22

**3 GHz – 20 GHz (10.0 MHz, Middle Channel)**

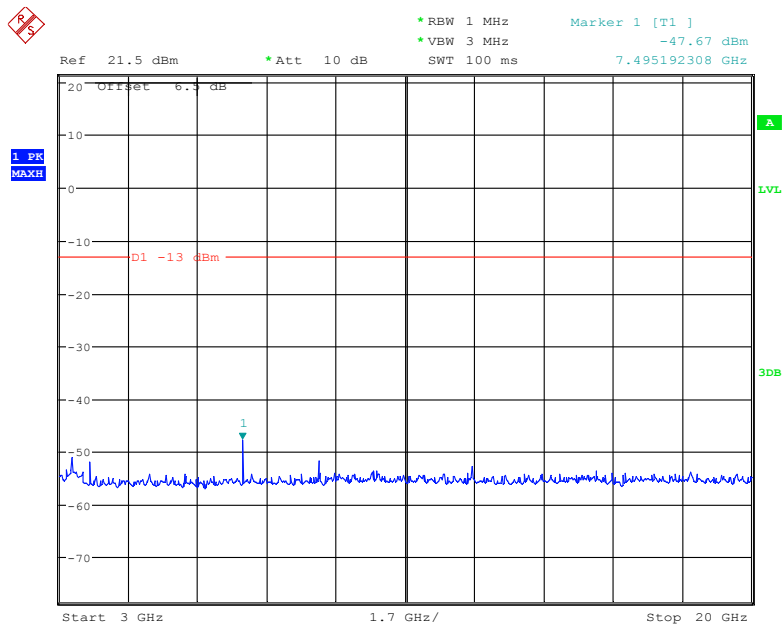

Date: 17.DEC.2019 13:28:52

**30 MHz - 1 GHz (15.0 MHz, Middle Channel)**

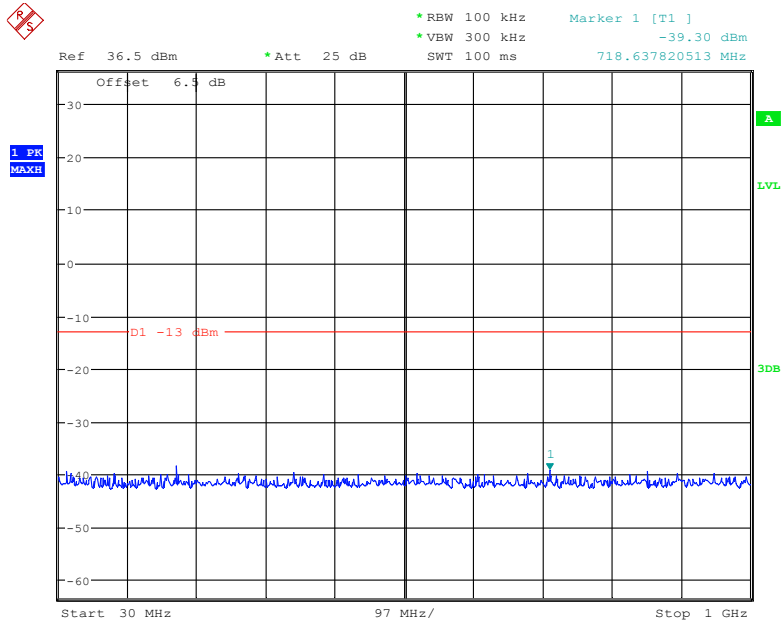

Date: 17.DEC.2019 13:31:36

**1 GHz - 3 GHz (15.0 MHz, Middle Channel)**

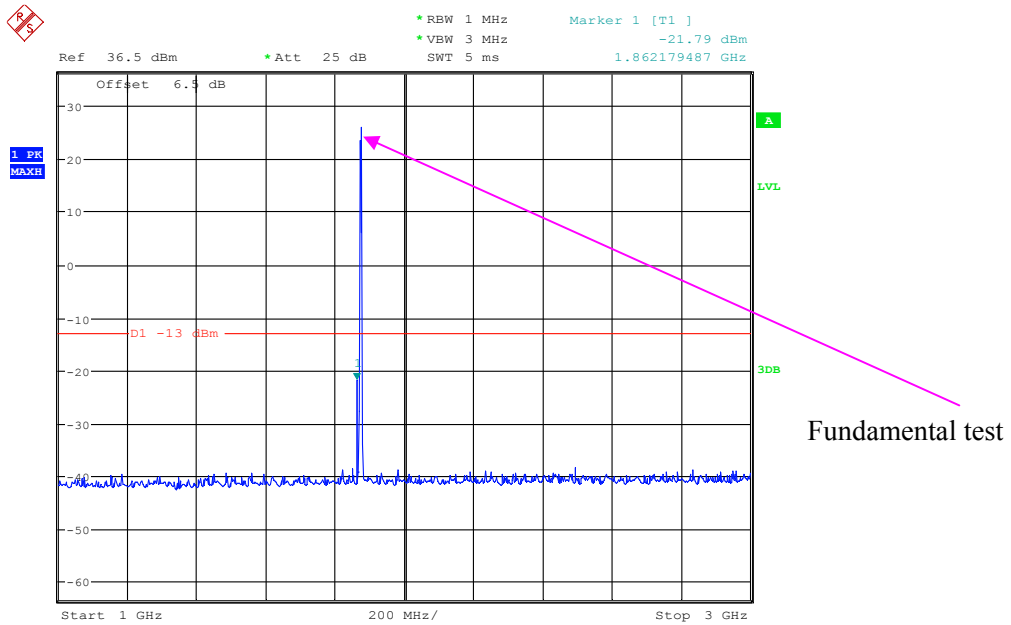

Date: 17.DEC.2019 13:30:59

### 3 GHz – 20 GHz (15.0 MHz, Middle Channel)

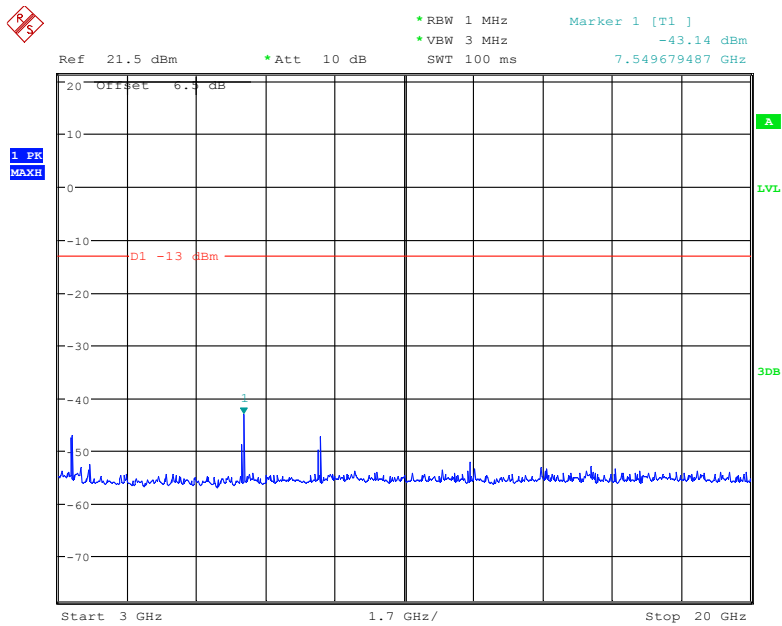

Date: 17.DEC.2019 13:29:35

### 30 MHz - 1 GHz (20.0 MHz, Middle Channel)

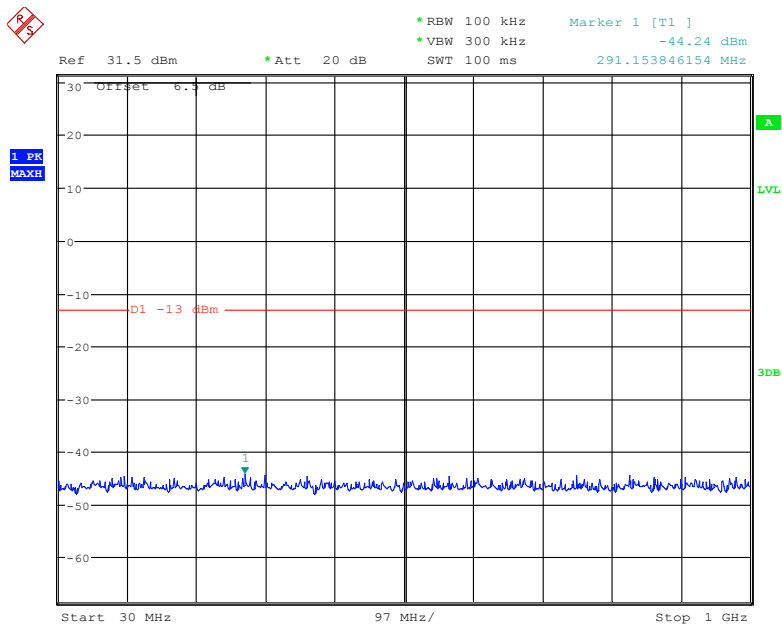

Date: 17.DEC.2019 13:09:38

**1 GHz – 3 GHz (20.0 MHz, Middle Channel)**

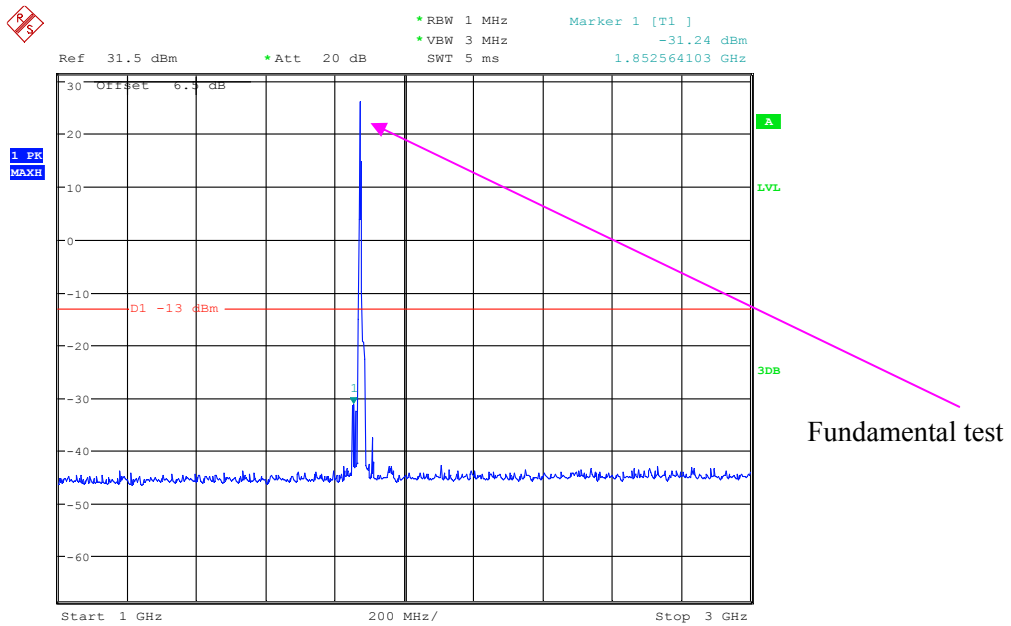

Date: 17.DEC.2019 13:10:43

**3 GHz - 20 GHz (20.0 MHz, Middle Channel)**

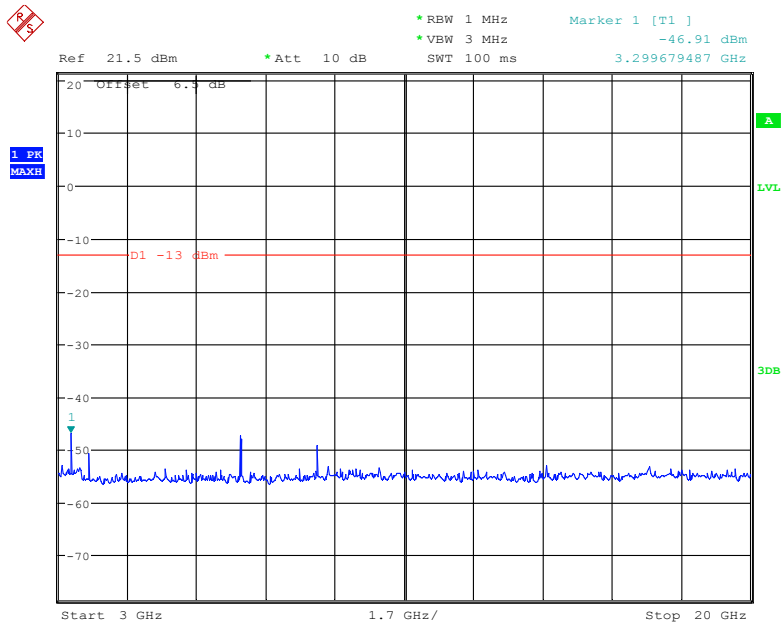

Date: 17.DEC.2019 13:11:47

LTE-M Band 4:

30 MHz - 1 GHz (5.0 MHz, Middle Channel)

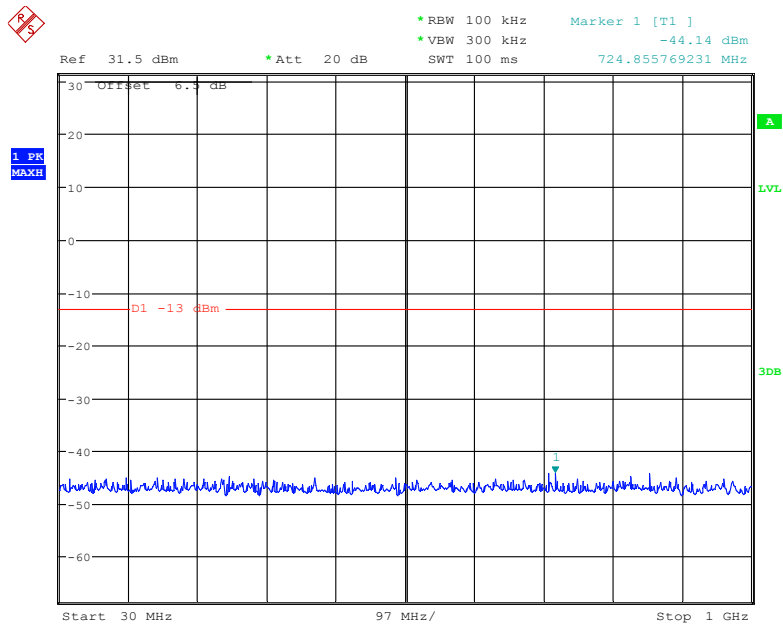

Date: 17.DEC.2019 13:36:12

1 GHz - 3 GHz (5.0 MHz, Middle Channel)

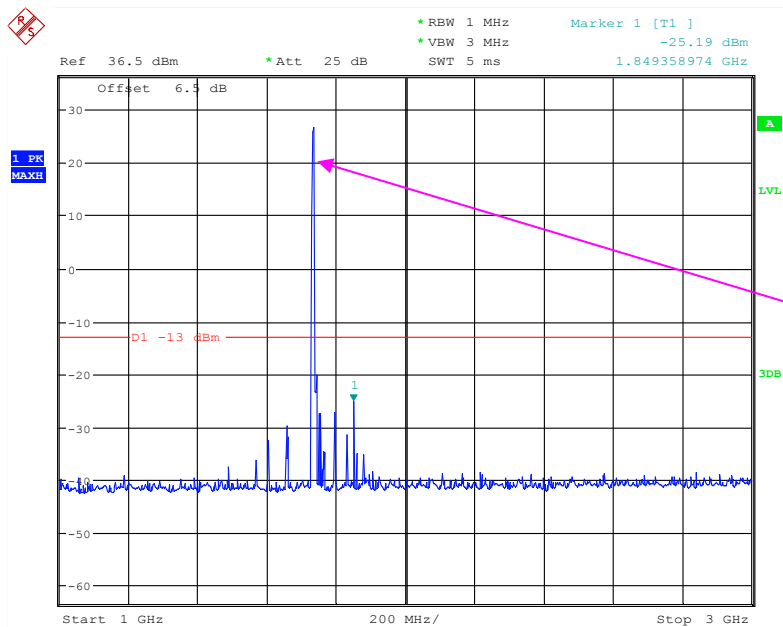

Date: 17.DEC.2019 13:35:48

### 3 GHz – 20 GHz (5.0 MHz, Middle Channel)

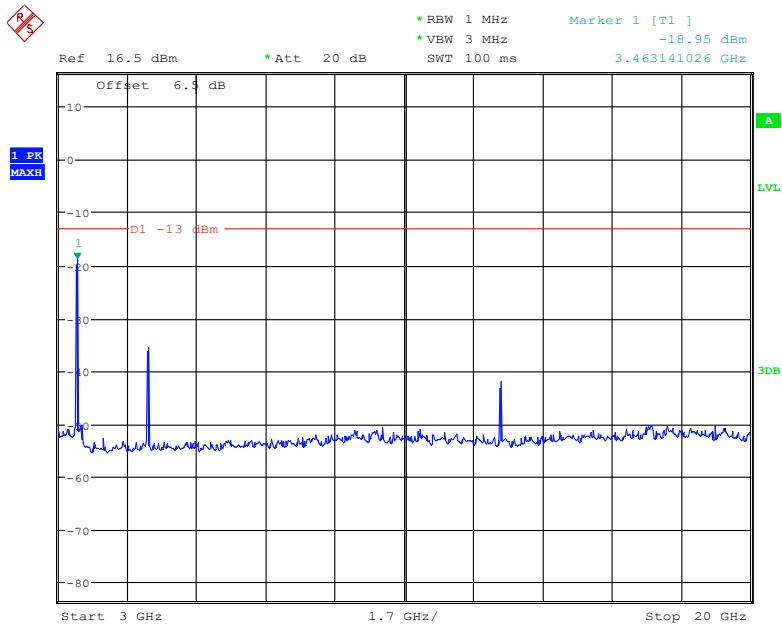

Date: 17.DEC.2019 13:34:37

### 30 MHz - 1 GHz (10.0 MHz, Middle Channel)

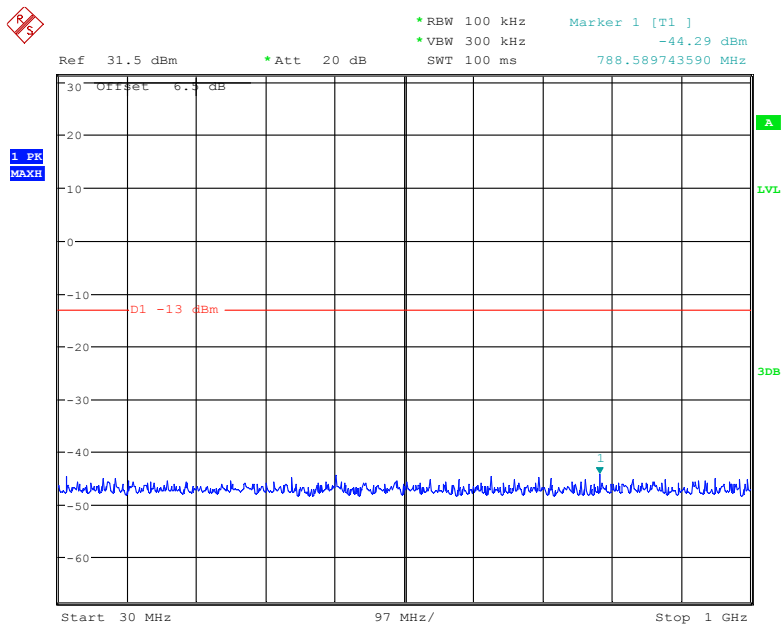

Date: 17.DEC.2019 13:37:07

### 1 GHz – 3 GHz (10.0 MHz, Middle Channel)

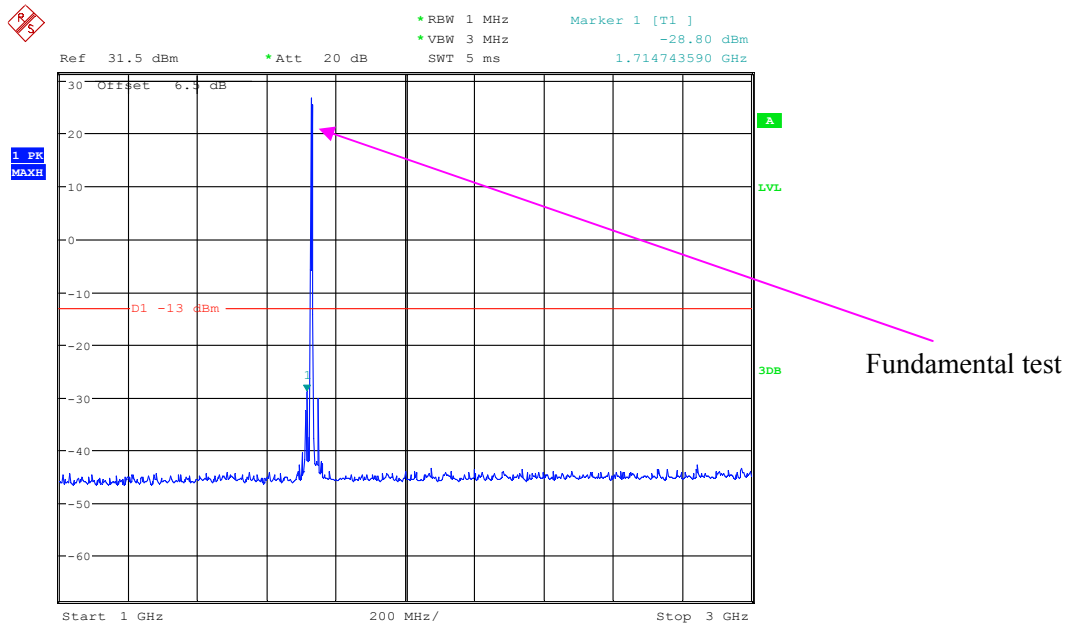

Date: 17.DEC.2019 13:39:51

### 3 GHz – 20 GHz (10.0 MHz, Middle Channel)

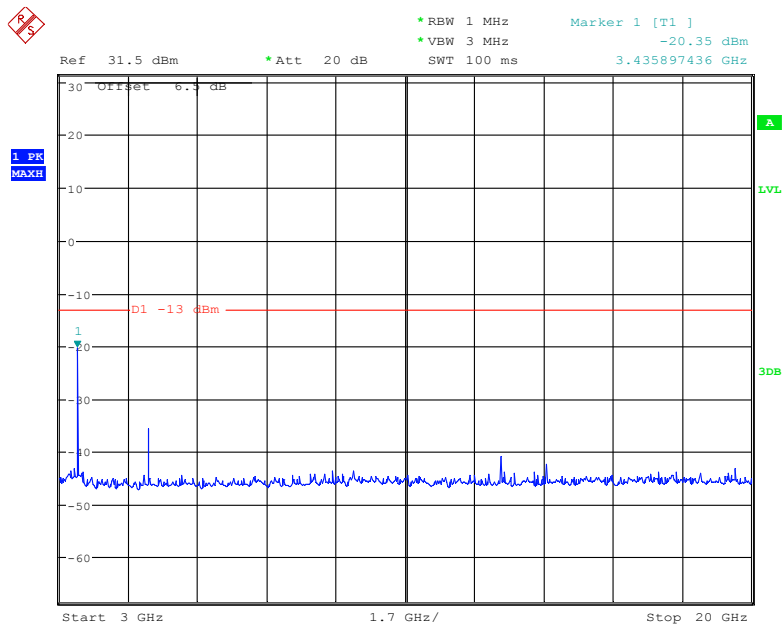

Date: 17.DEC.2019 13:40:09

### 30 MHz - 1 GHz (15.0 MHz, Middle Channel)

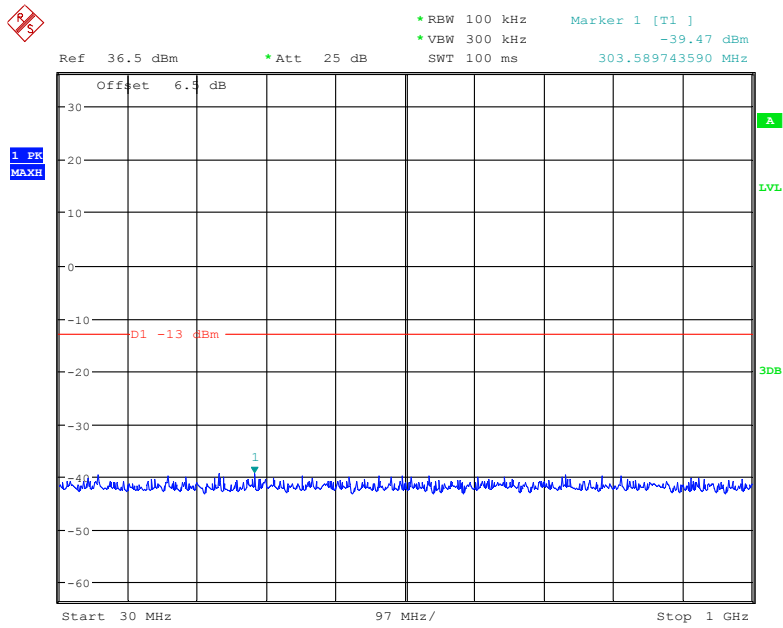

Date: 17.DEC.2019 13:32:47

### 1 GHz - 3 GHz (15.0 MHz, Middle Channel)

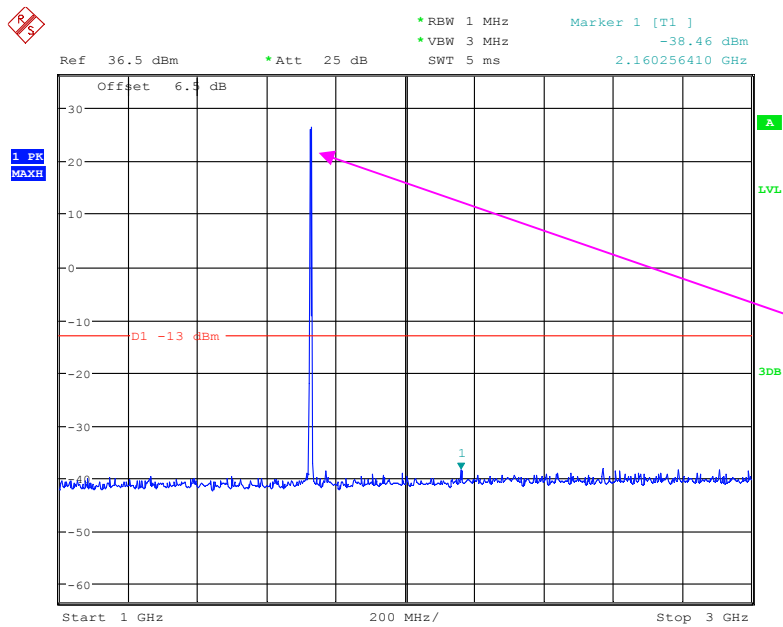

Date: 17.DEC.2019 13:33:14



### 3 GHz – 20 GHz (15.0 MHz, Middle Channel)

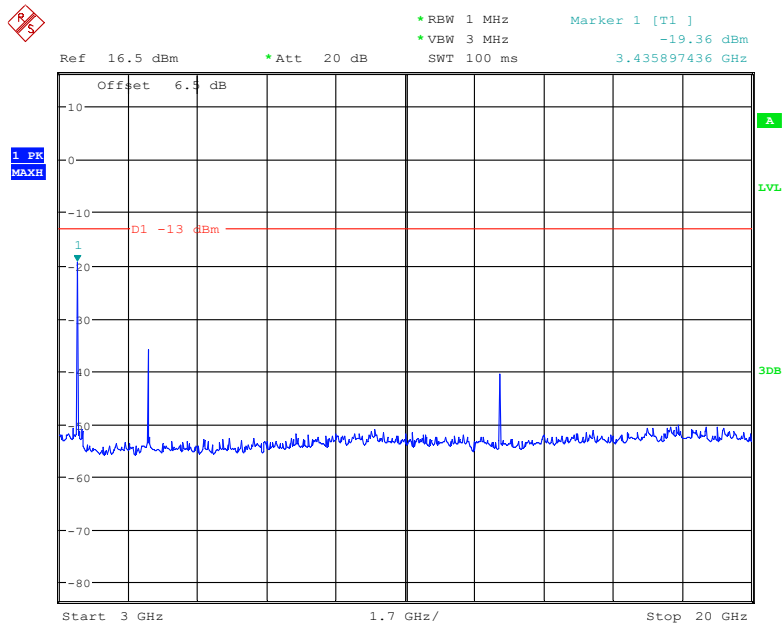

Date: 17.DEC.2019 13:33:49

### 30 MHz - 1 GHz (20.0 MHz, Middle Channel)

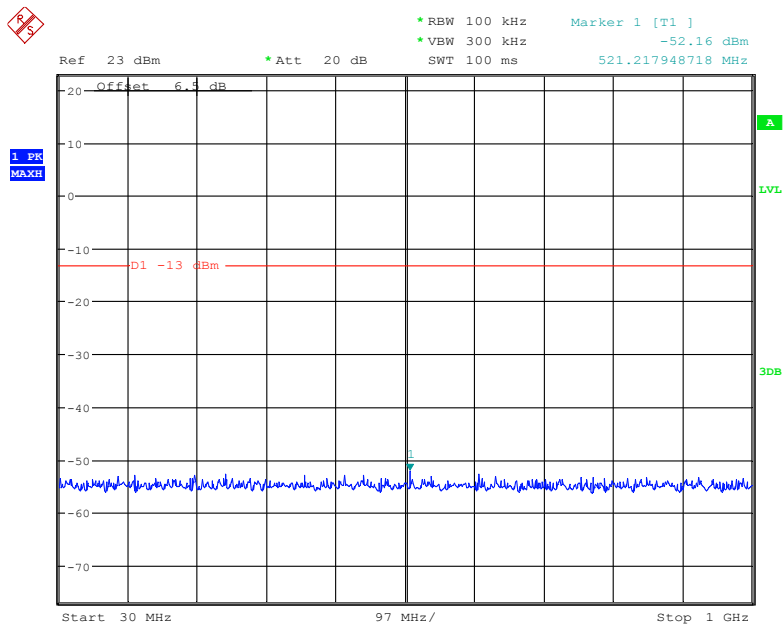

Date: 17.DEC.2019 13:43:31

### 1 GHz – 3 GHz (20.0 MHz, Middle Channel)

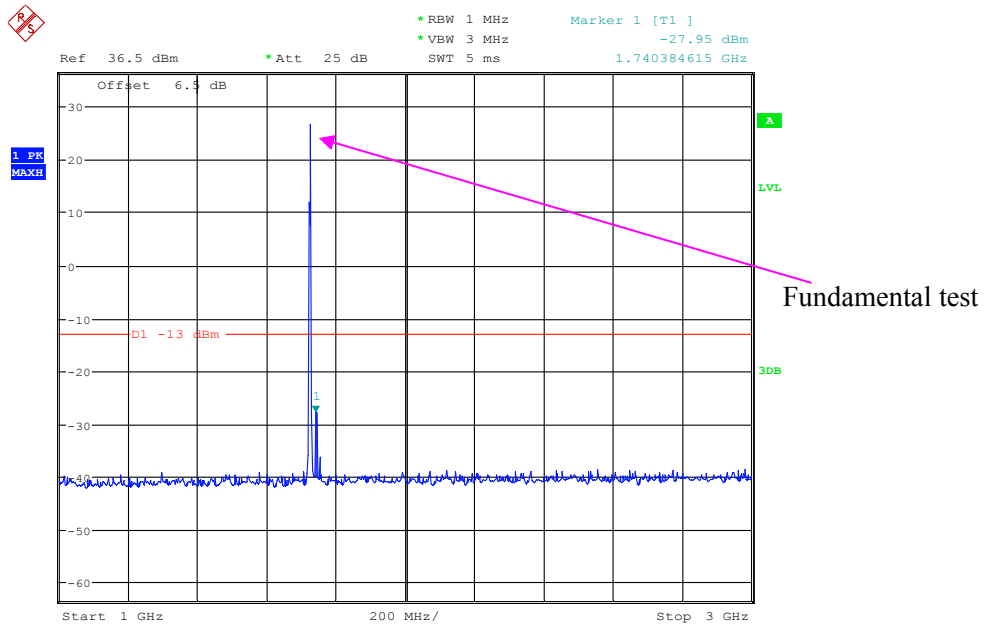

Date: 17.DEC.2019 13:42:18

### 3 GHz – 20 GHz (20.0 MHz, Middle Channel)

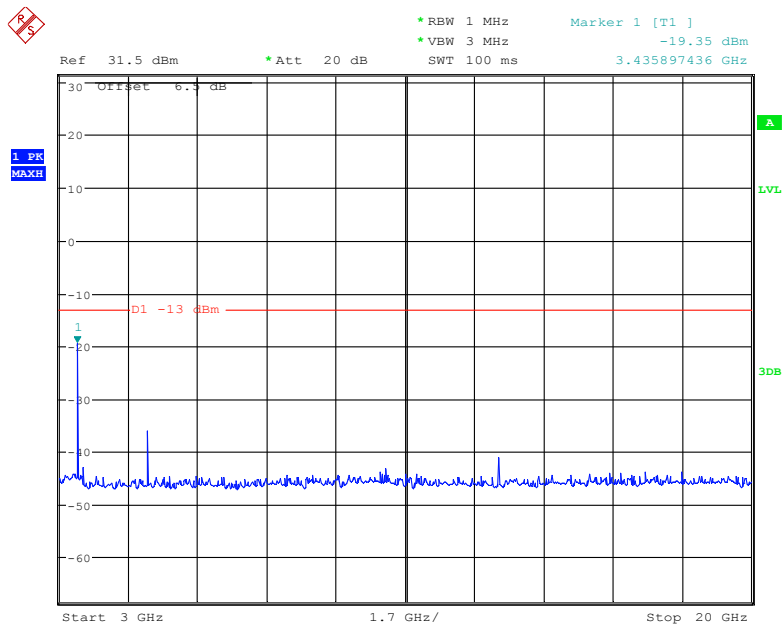

Date: 17.DEC.2019 13:42:43

**LTE-M Band 12:**

**30 MHz – 1 GHz (5.0 MHz, Middle Channel)**

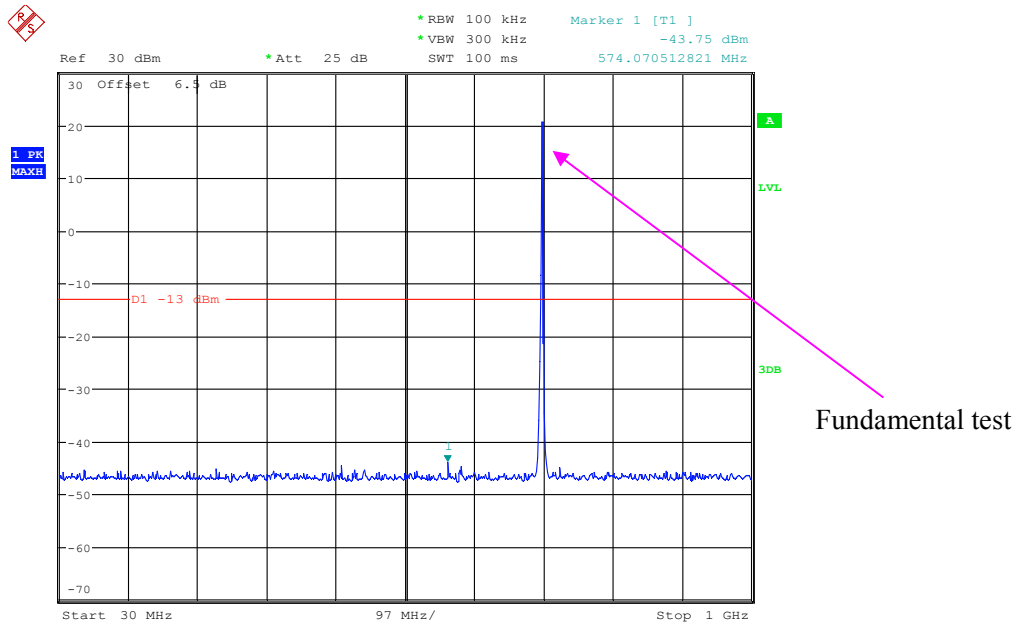

Date: 17.DEC.2019 13:49:20

**1 GHz – 10GHz (5.0 MHz, Middle Channel)**

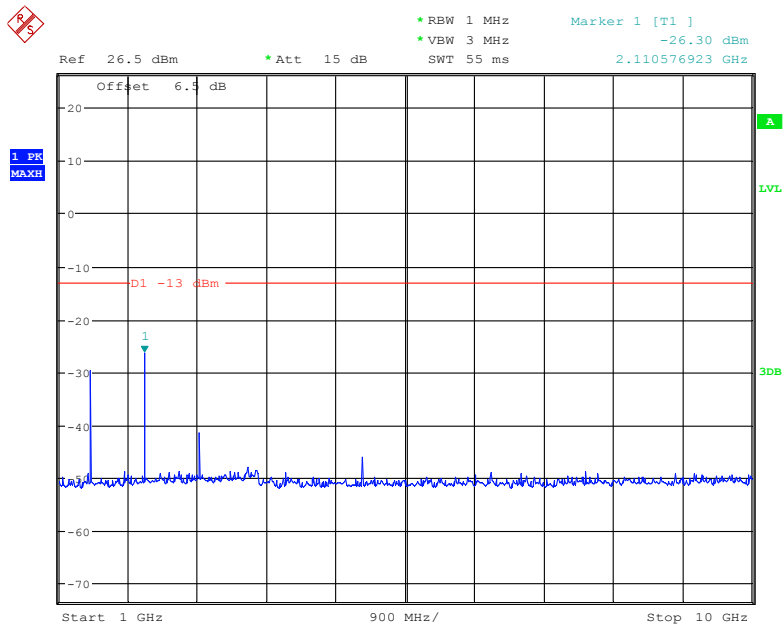

Date: 17.DEC.2019 13:49:49

### 30 MHz – 1 GHz (10.0 MHz, Middle Channel)

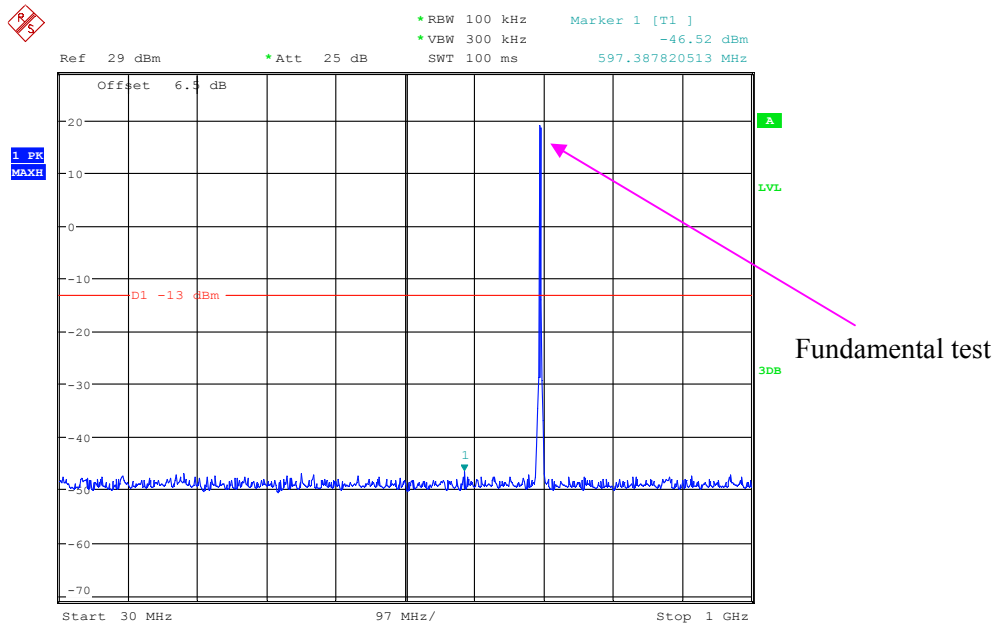

Date: 17.DEC.2019 13:50:57

### 1 GHz – 10 GHz (10.0 MHz, Middle Channel)

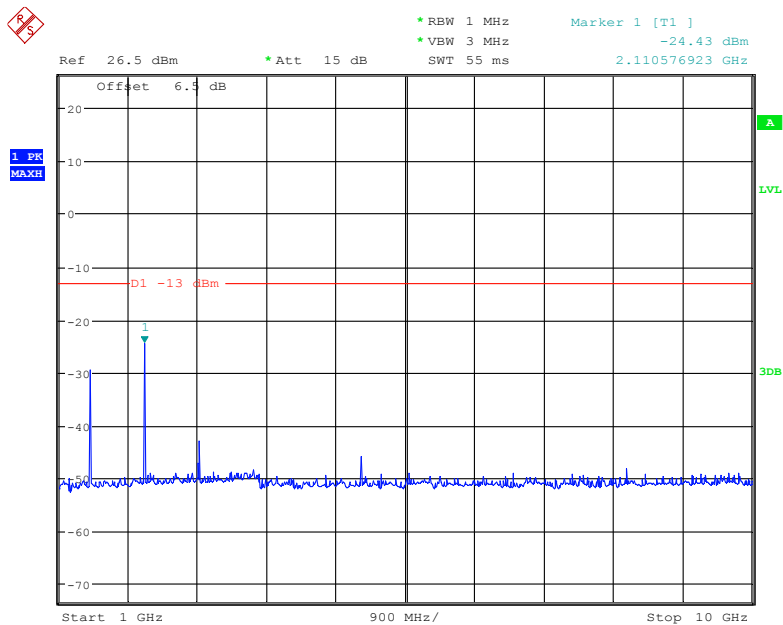

Date: 17.DEC.2019 13:50:22

**LTE-M Band 13:**

**30 MHz – 1 GHz (5.0 MHz, Middle Channel)**

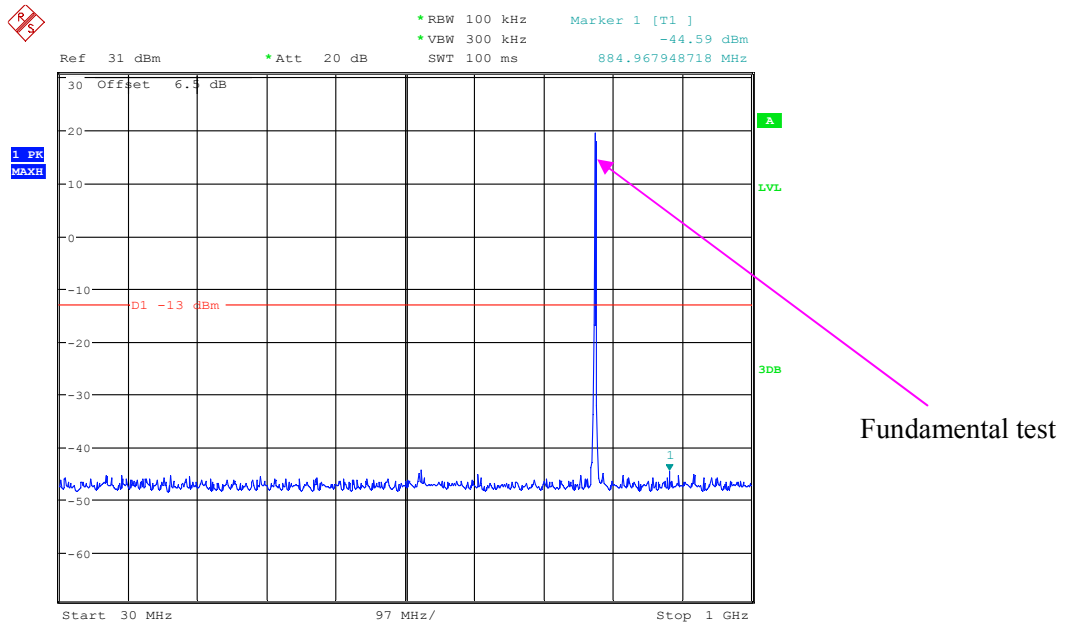

Date: 17.DEC.2019 13:55:11

**1 GHz – 10GHz (5.0 MHz, Middle Channel)**

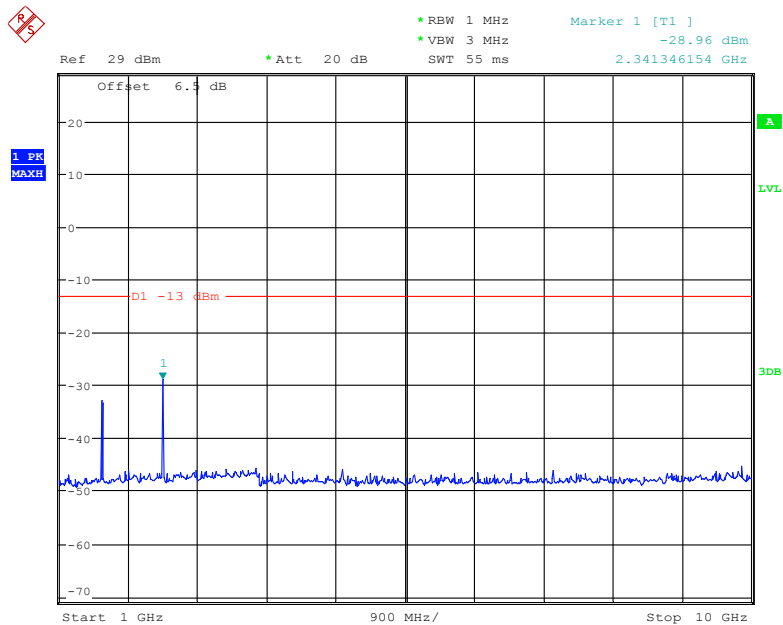

Date: 17.DEC.2019 13:54:40

### 763 MHz – 775 MHz (5.0 MHz, Middle Channel)

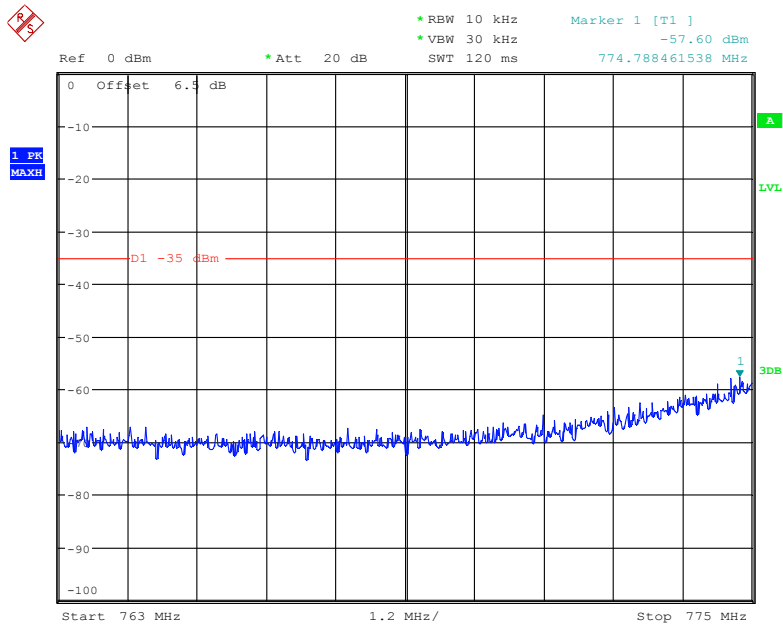

Date: 17.DEC.2019 13:58:18

### 793 MHz – 806 MHz (5.0 MHz, Middle Channel)

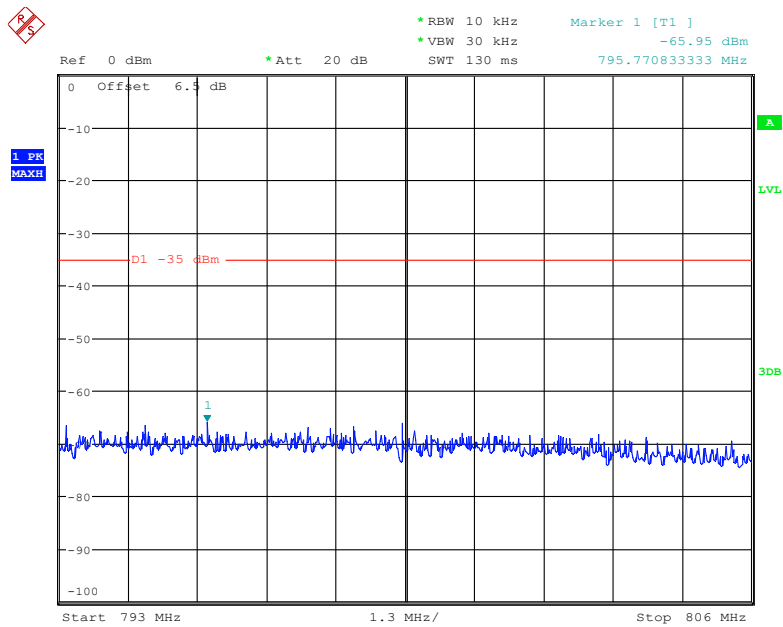

Date: 17.DEC.2019 13:59:01

**Additional band emission (add antenna gain for below two plots):  
1.559 GHz – 1.610 GHz (5.0 MHz, Middle Channel)**

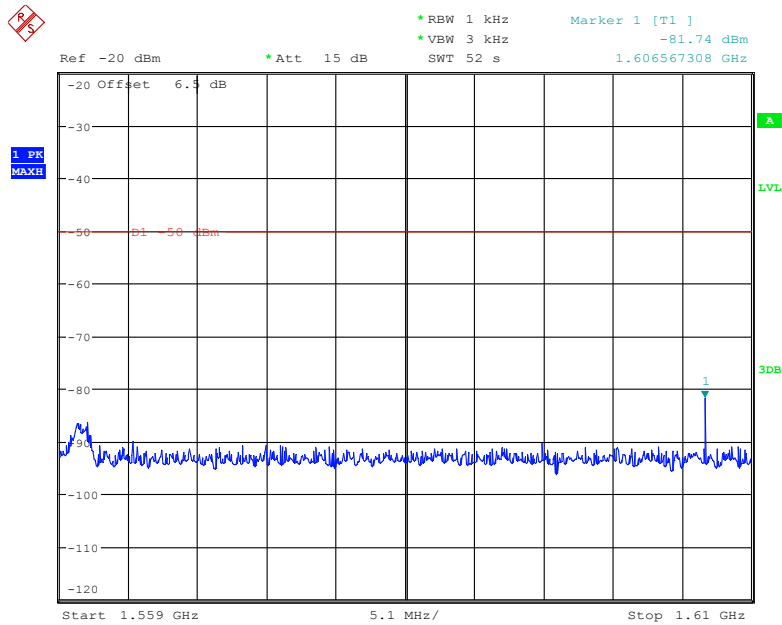

Date: 17.DEC.2019 14:09:56

**1.559 GHz – 1.610 GHz (5.0 MHz, Middle Channel)**

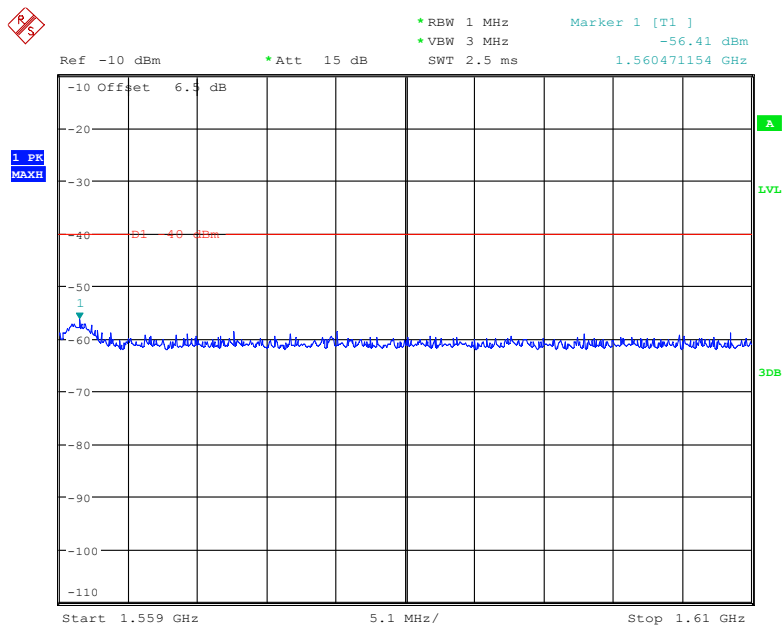

Date: 17.DEC.2019 14:07:28

### 30 MHz – 1 GHz (10.0 MHz, Middle Channel)

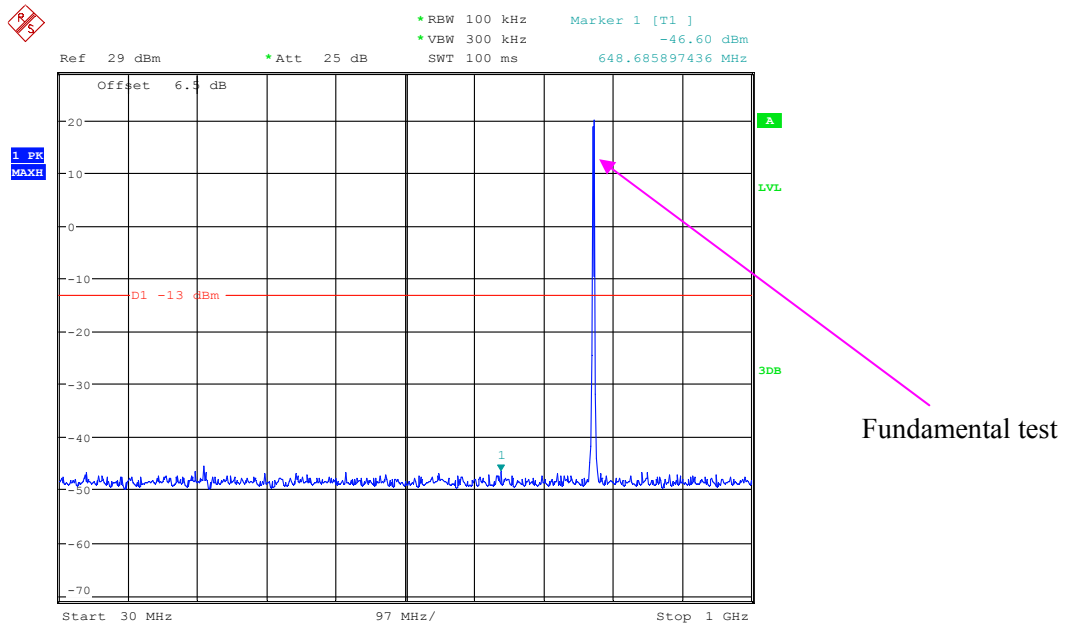

Date: 17.DEC.2019 13:52:12

### 1 GHz – 10 GHz (10.0 MHz, Middle Channel)

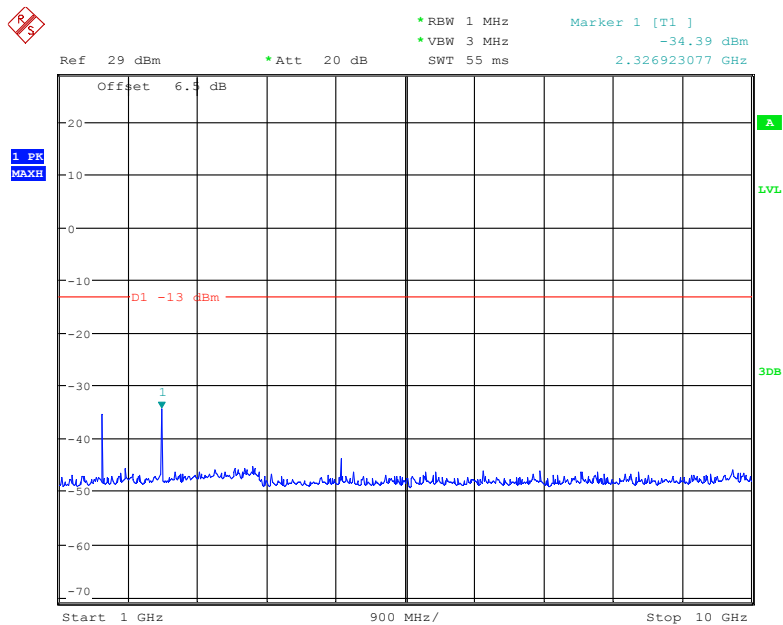

Date: 17.DEC.2019 13:52:41



763 MHz – 775 MHz (10.0 MHz, Middle Channel)

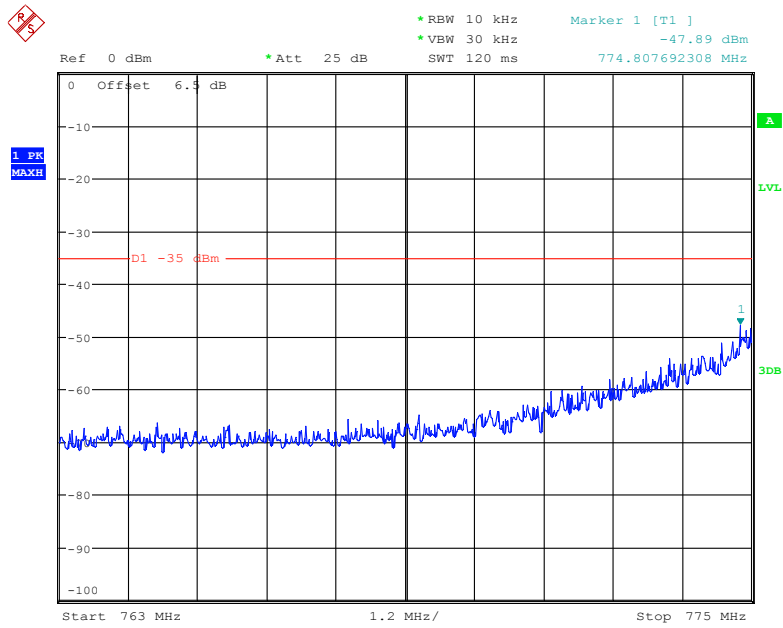

Date: 17.DEC.2019 14:14:46

793 MHz – 806 MHz (10.0 MHz, Middle Channel)

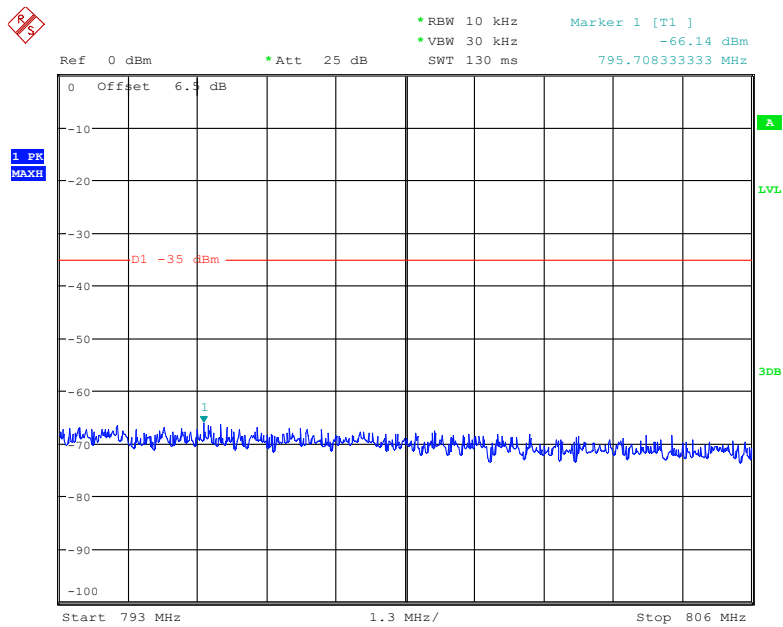

Date: 17.DEC.2019 14:15:18

Additional band emission (add antenna gain for below two plots):

1.559 GHz – 1.610 GHz (10.0 MHz, Middle Channel)

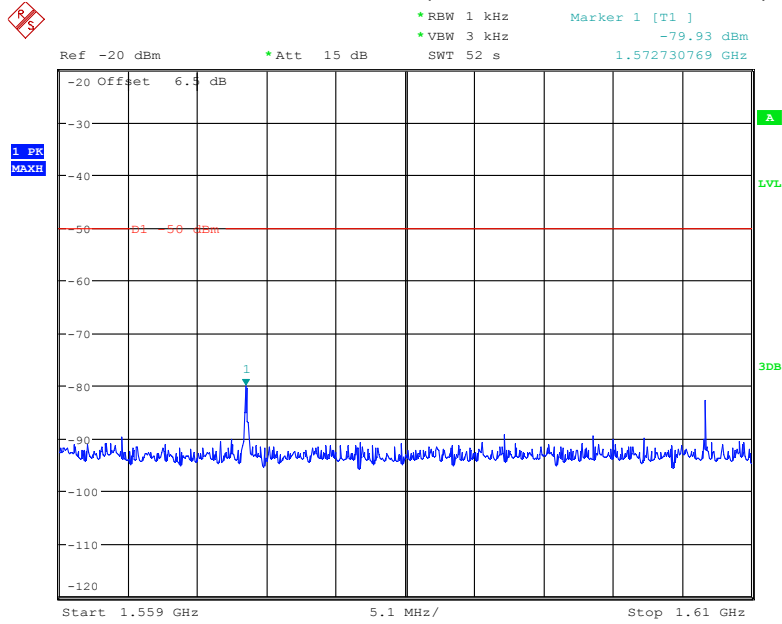

Date: 17.DEC.2019 14:11:31

1.559 GHz – 1.610 GHz (10.0 MHz, Middle Channel)

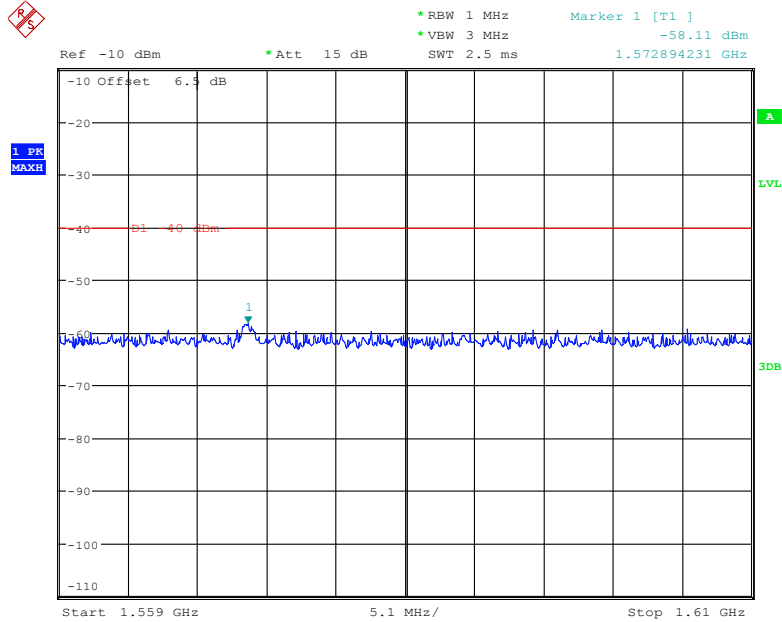

Date: 17.DEC.2019 14:11:57

**FCC § 2.1053; § 24.238 (a); § 27.53 SPURIOUS RADIATED EMISSIONS****Applicable Standard**

FCC § 2.1053, § 24.238(a) and § 27.53

**Test Procedure**

The transmitter was placed on a wooden turntable, and it was transmitting into a non-radiating load which was also placed on the turntable.

The measurement antenna was placed at a distance of 3 meters from the EUT. During the tests, the receiving antenna height and polarization as well as EUT azimuth were varied in order to identify the maximum level of emissions from the EUT. The test was performed by placing the EUT on 3-orthogonal axis.

The frequency range up to tenth harmonic of the fundamental frequency was investigated.

**Test Data****Environmental Conditions**

<b>Temperature:</b>	25 °C
<b>Relative Humidity:</b>	59 %
<b>ATM Pressure:</b>	101.0 kPa

*The testing was performed by Zero Yan and Alan He on 2019-12-18.*

*EUT operation mode: Transmitting*

Pre-scan with Low, Middle and High channel, the worst case as below:

**LTE-M Band:** (Pre-scan with all the bandwidth, and worse case as below)

Frequency (MHz)	Receiver Reading (dBµV)	Turntable Angle Degree	Rx Antenna		Substituted			Absolute Level (dBm)	Limit (dBm)	Margin (dB)
			Height (m)	Polar (H/V)	Level (dBm)	Cable Loss (dB)	Antenna Gain (dBd/dBi)			
<b>Band 2, Middle Channel(1880MHz)</b>										
961.35	37.61	292	2.2	H	-63.0	1.37	0.0	-64.37	-13	51.37
961.35	38.31	153	1.6	V	-61.0	1.37	0.0	-62.37	-13	49.37
3760.00	59.80	170	1.4	H	-42.3	1.50	11.80	-32.00	-13	19.00
3760.00	56.52	32	2.3	V	-45.1	1.50	11.80	-34.80	-13	21.80
<b>Band 4, Middle Channel(1732.5MHz)</b>										
961.35	37.14	200	2.4	H	-63.4	1.37	0.0	-64.77	-13	51.77
961.35	38.03	65	1.7	V	-61.3	1.37	0.0	-62.67	-13	49.67
5197.50	56.61	266	2.1	H	-43.5	1.60	12.10	-33.00	-13	20.00
5197.50	58.14	217	1.2	V	-41.5	1.60	12.10	-31.00	-13	18.00
<b>Band 12, Middle Channel(707.5MHz)</b>										
961.35	38.91	272	1.9	H	-61.7	1.37	0.0	-63.07	-13	50.07
961.35	37.18	16	1.3	V	-62.2	1.37	0.0	-63.57	-13	50.57
1415.00	45.42	26	1.5	H	-62.8	1.60	7.90	-56.50	-13	43.50
1415.00	56.74	170	1.8	V	-51.7	1.60	7.90	-45.40	-13	32.40
2122.50	48.92	125	2.0	H	-52.2	1.30	9.70	-43.80	-13	30.80
2122.50	56.56	147	1.3	V	-45.4	1.30	9.70	-37.00	-13	24.00
2830.00	51.26	49	1.5	H	-52.7	1.80	10.50	-44.00	-13	31.00
2830.00	50.65	147	2.5	V	-53.0	1.80	10.50	-44.30	-13	31.30
<b>Band 13, Middle Channel(782MHz)</b>										
961.35	38.63	157	2.2	H	-61.9	1.37	0.0	-63.27	-13	50.27
961.35	37.42	90	1.8	V	-61.9	1.37	0.0	-63.27	-13	50.27
1564.00	45.90	257	1.3	H	-62.2	1.40	8.70	-54.90	-40	14.90
1564.00	55.60	88	1.7	V	-52.3	1.40	8.70	-45.00	-40	5.00
3128.00	45.20	81	2.3	H	-56.4	1.70	11.30	-46.80	-13	33.80
3128.00	49.18	108	1.0	V	-52.3	1.70	11.30	-42.70	-13	29.70

**Note:**

Absolute Level = Substituted Level - Cable loss + Antenna Gain

Margin = Limit- Absolute Level

dBd is for the ERP, dBi is for EIRP.

**FCC § 24.238 (a); §27.53 (h)(m) - BAND EDGES**

**Applicable Standard**

According to §24.238(a), the power of any emissions outside of the authorized operating frequency ranges must be attenuated below the transmitting power (P) by a factor of at least  $43 + 10 \log(P)$  dB.

According to FCC §27.53 (h)(m), the power of any emission outside of the authorized operating frequency ranges must be attenuated below the transmitting power (P) by a factor of at least  $43 + 10 \log(P)$  dB.

**Test Procedure**

The RF output of the transmitter was connected to the input of the spectrum analyzer through sufficient attenuation.

The center of the spectrum analyzer was set to block edge frequency

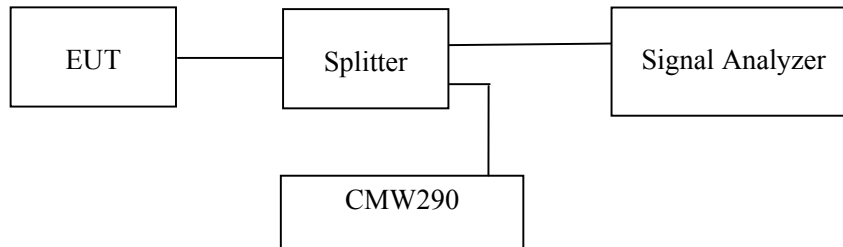

**Test Data**

**Environmental Conditions**

<b>Temperature:</b>	25 °C
<b>Relative Humidity:</b>	52 %
<b>ATM Pressure:</b>	101.0 kPa

*The testing was performed by Gavin Guo on 2019-12-17.*

*EUT operation mode: Transmitting*

*Test Result: Compliance. Please refer to the following plots.*

**Band 2:**

**QPSK (5.0 MHz, FULL RB) - Left Band Edge**

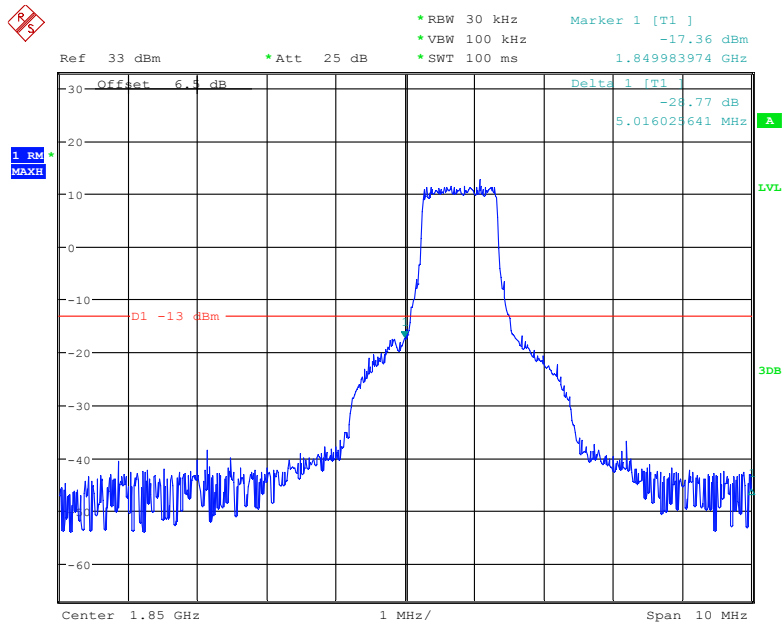

Date: 17.DEC.2019 15:40:04

**QPSK (5.0 MHz, FULL RB) - Right Band Edge**

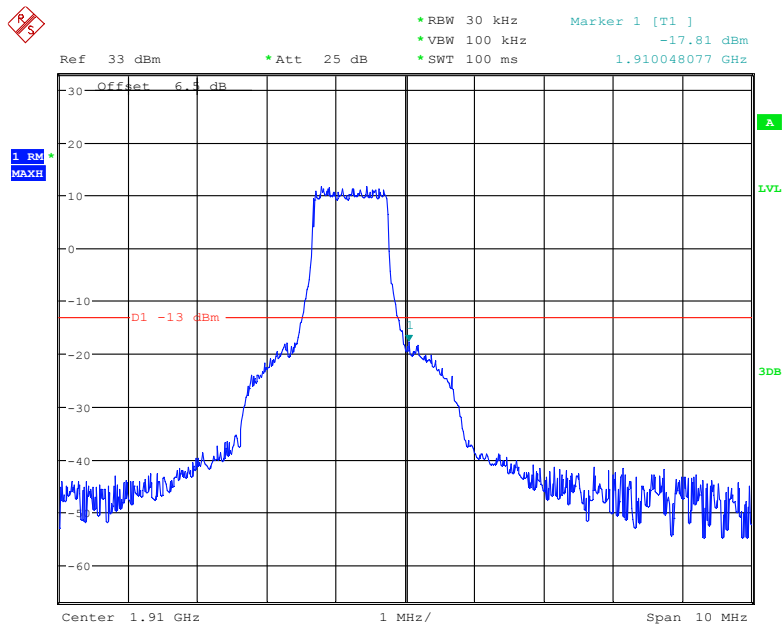

Date: 17.DEC.2019 15:43:18

### 16-QAM (5.0 MHz, FULL RB) - Left Band Edge

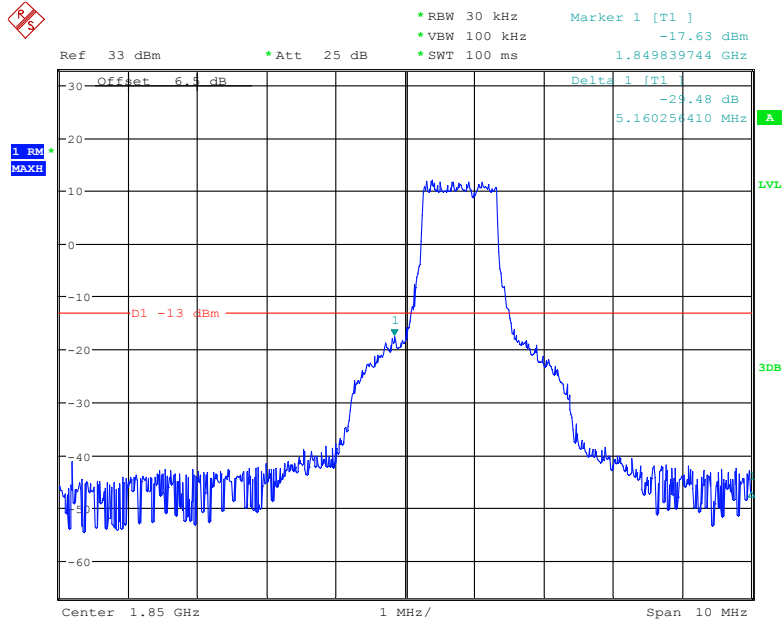

Date: 17.DEC.2019 15:40:39

### 16-QAM (5.0 MHz, FULL RB) - Right Band Edge

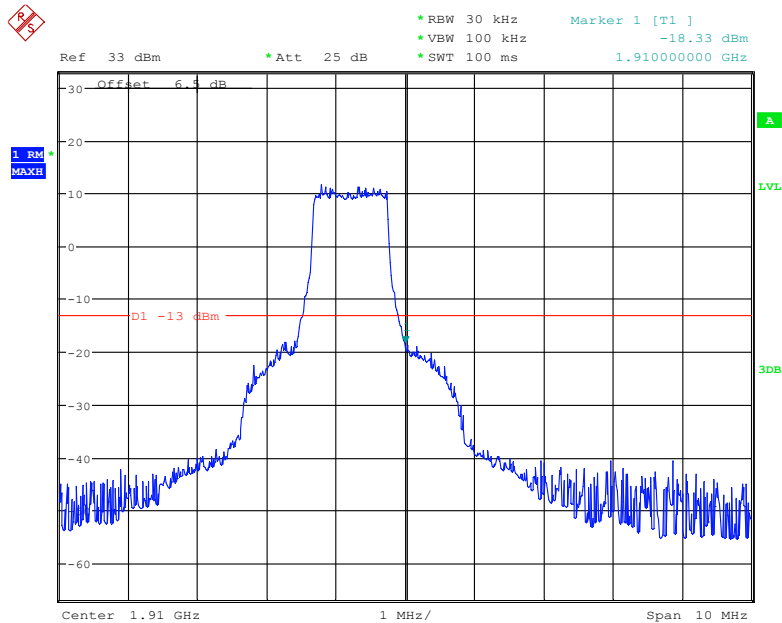

Date: 17.DEC.2019 15:43:55

### QPSK (10.0 MHz, FULL RB) - Left Band Edge

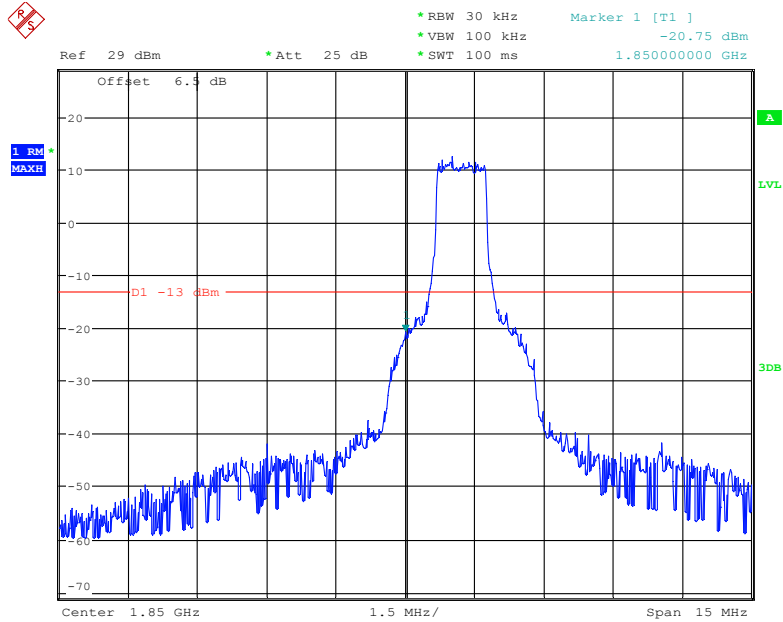

Date: 17.DEC.2019 15:29:02

### QPSK (10.0 MHz, FULL RB) - Right Band Edge

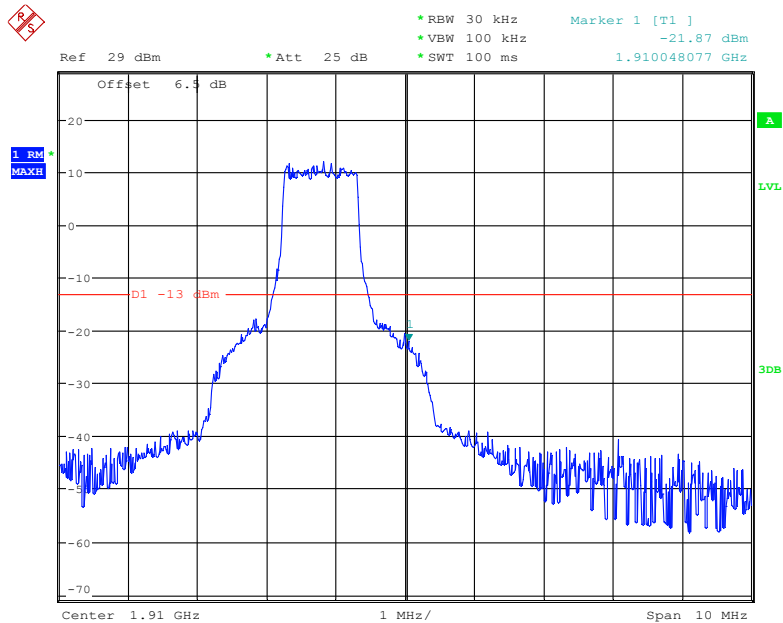

Date: 17.DEC.2019 15:32:31



### 16-QAM (10.0 MHz, FULL RB) - Left Band Edge

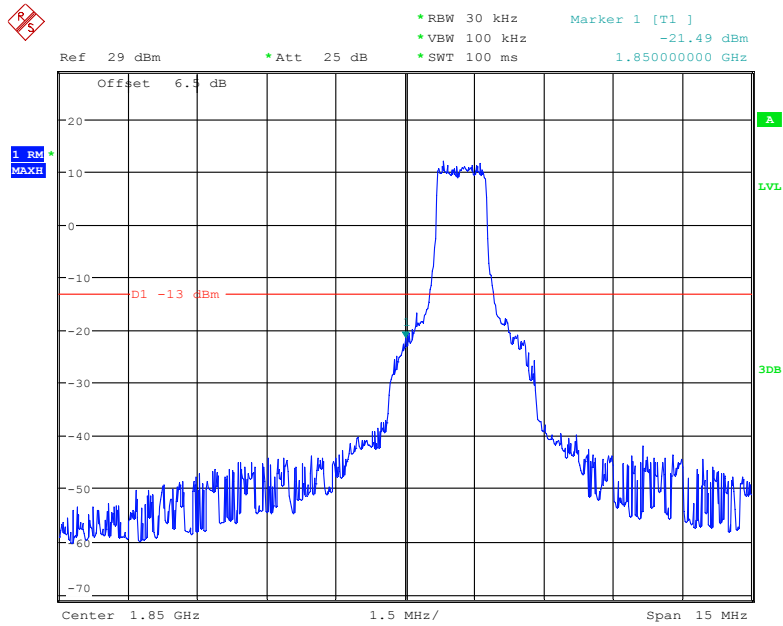

Date: 17.DEC.2019 15:29:30

### 16-QAM (10.0 MHz, FULL RB) - Right Band Edge

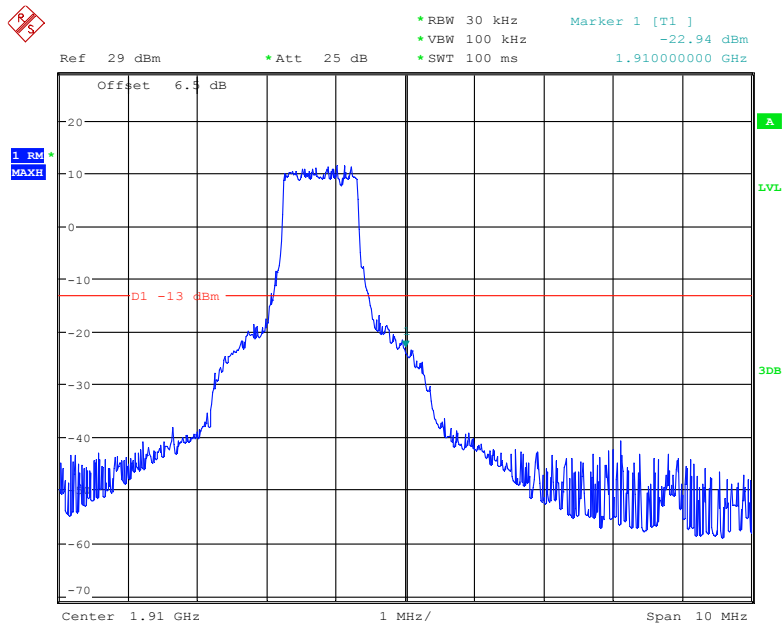

Date: 17.DEC.2019 15:33:12

### QPSK (15.0 MHz, FULL RB) - Left Band Edge

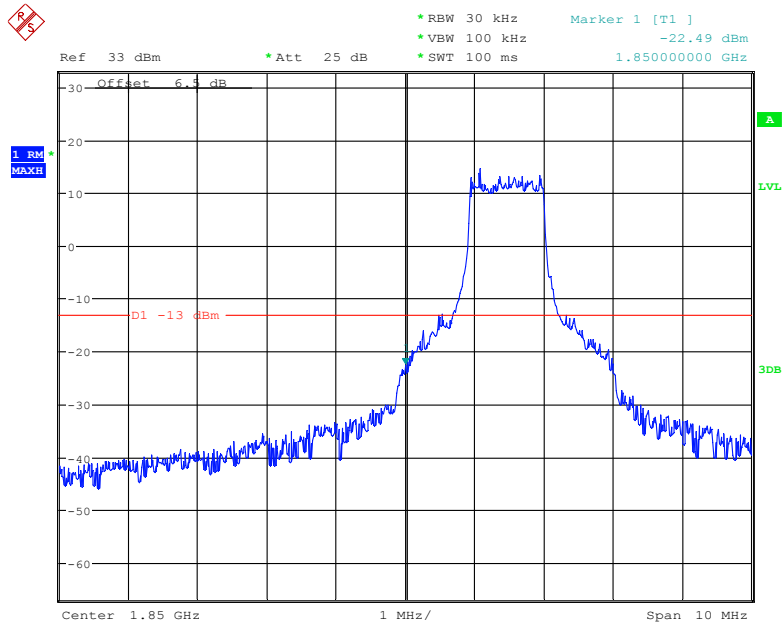

Date: 17.DEC.2019 15:54:12

### QPSK (15.0 MHz, FULL RB) - Right Band Edge

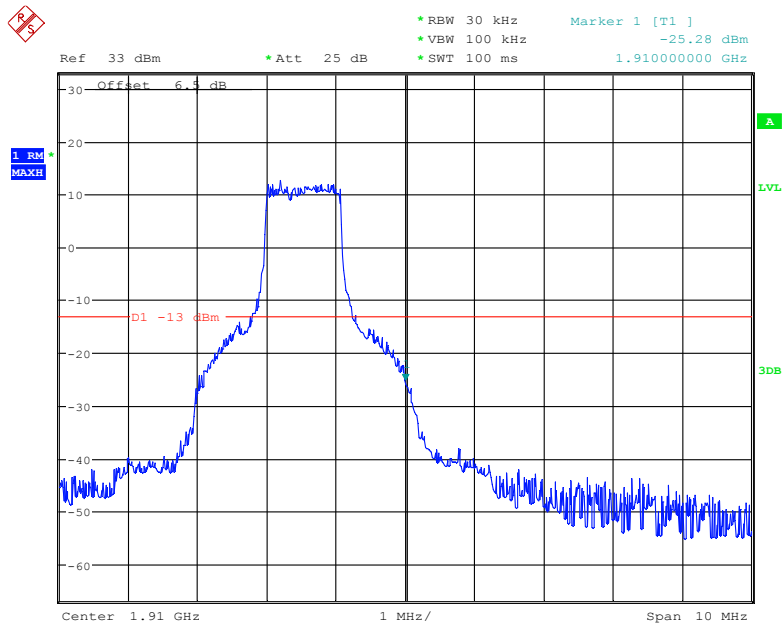

Date: 17.DEC.2019 15:57:01

### 16-QAM (15.0 MHz, FULL RB) - Left Band Edge

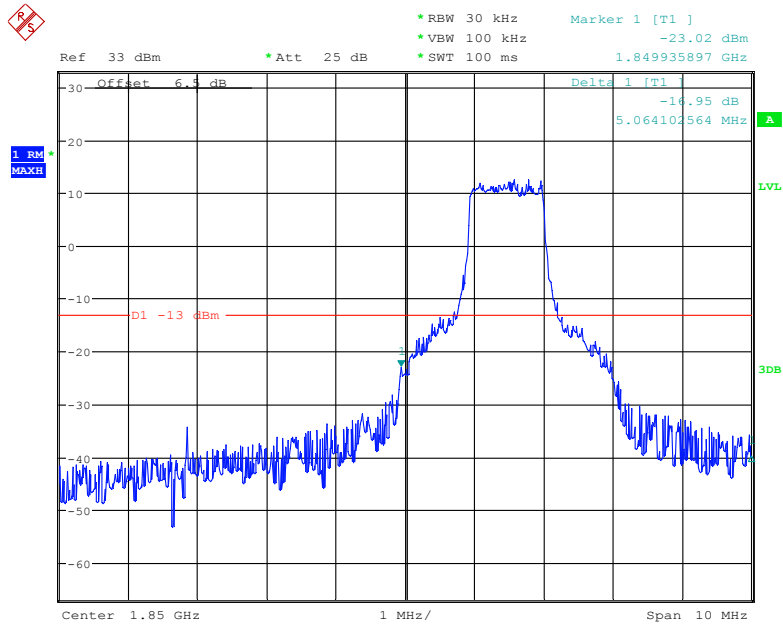

Date: 17.DEC.2019 15:53:08

### 16-QAM (15.0 MHz, FULL RB) - Right Band Edge

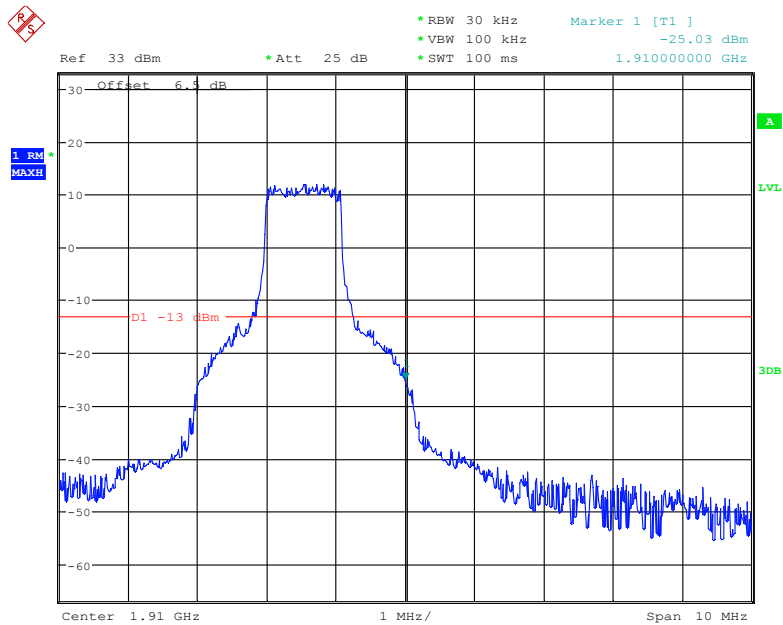

Date: 17.DEC.2019 15:56:29

### QPSK (20.0 MHz, FULL RB) - Left Band Edge

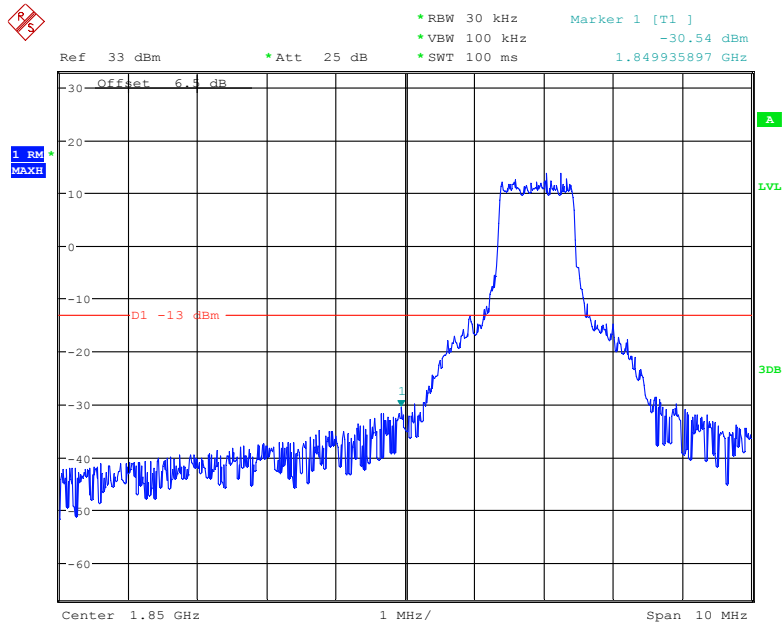

Date: 17.DEC.2019 15:59:53

### QPSK (20.0 MHz, FULL RB) - Right Band Edge

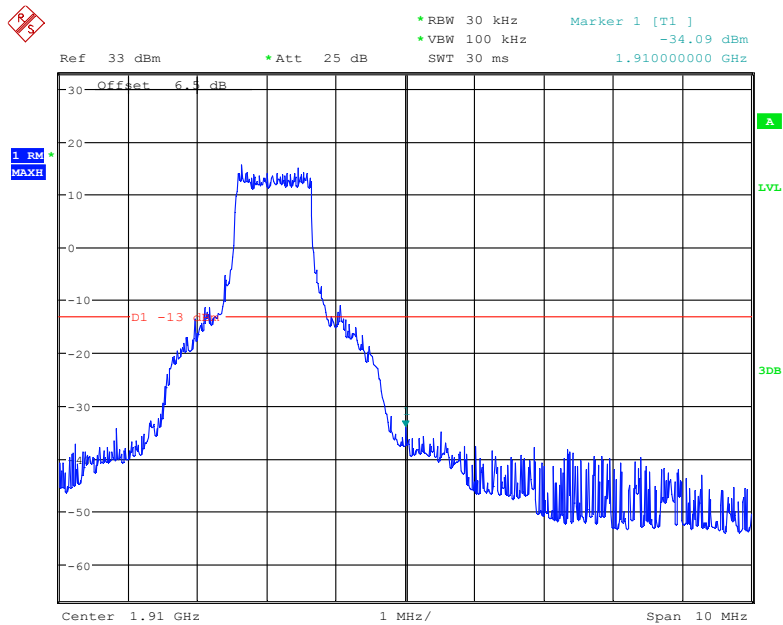

Date: 17.DEC.2019 16:08:12

### 16-QAM (20.0 MHz, FULL RB) - Left Band Edge

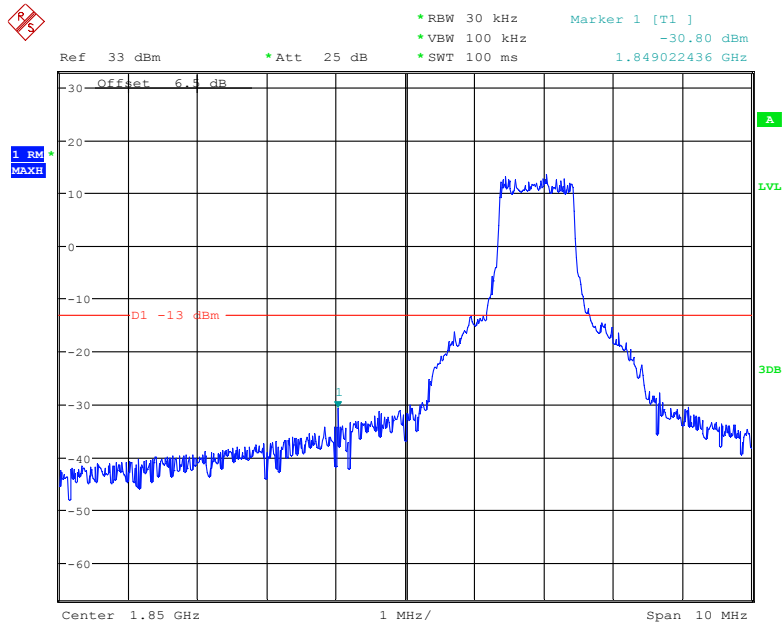

Date: 17.DEC.2019 15:59:19

### 16-QAM (20.0 MHz, FULL RB) - Right Band Edge

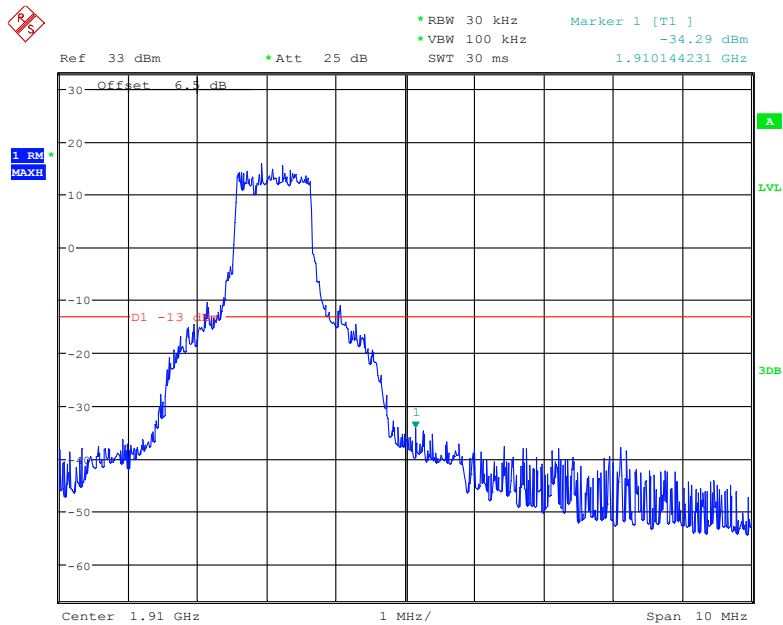

Date: 17.DEC.2019 16:07:39

**Band 4:**

**QPSK (5.0 MHz, FULL RB) - Left Band Edge**

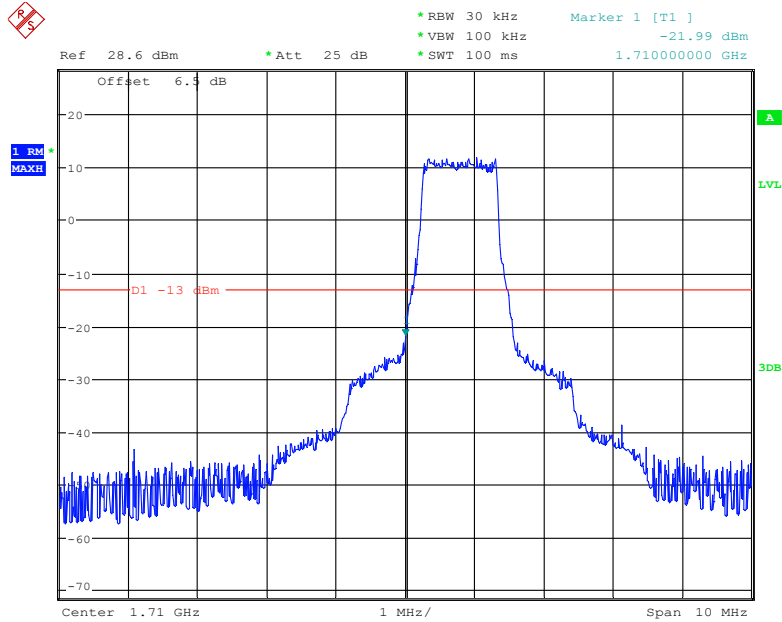

Date: 17.DEC.2019 16:57:44

**QPSK (5.0 MHz, FULL RB) - Right Band Edge**

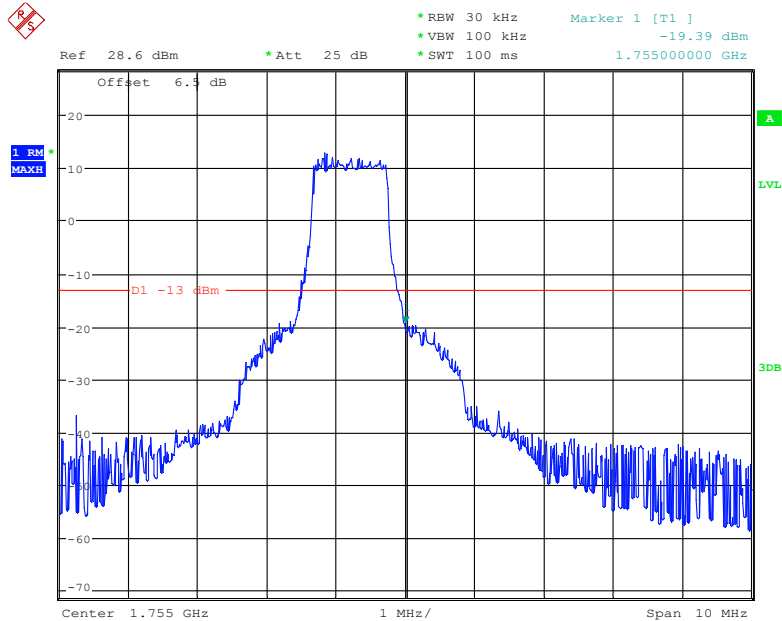

Date: 17.DEC.2019 17:01:22

### 16-QAM (5.0 MHz, FULL RB) - Left Band Edge

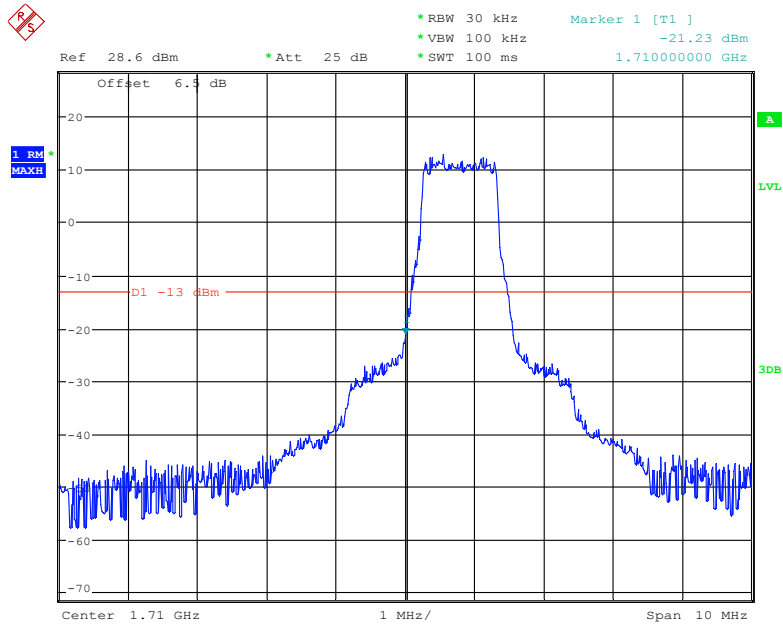

Date: 17.DEC.2019 16:57:00

### 16-QAM (5.0 MHz, FULL RB) - Right Band Edge

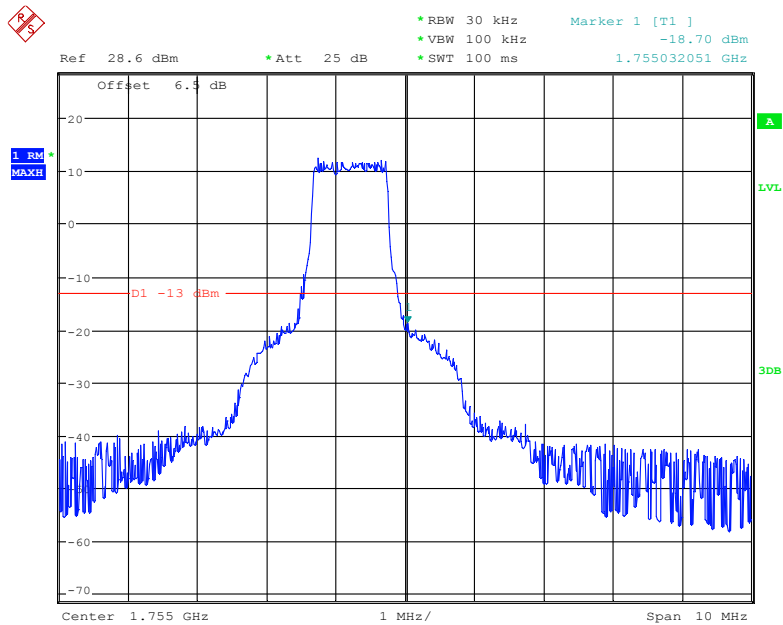

Date: 17.DEC.2019 17:00:56

### QPSK (10.0 MHz, FULL RB) - Left Band Edge

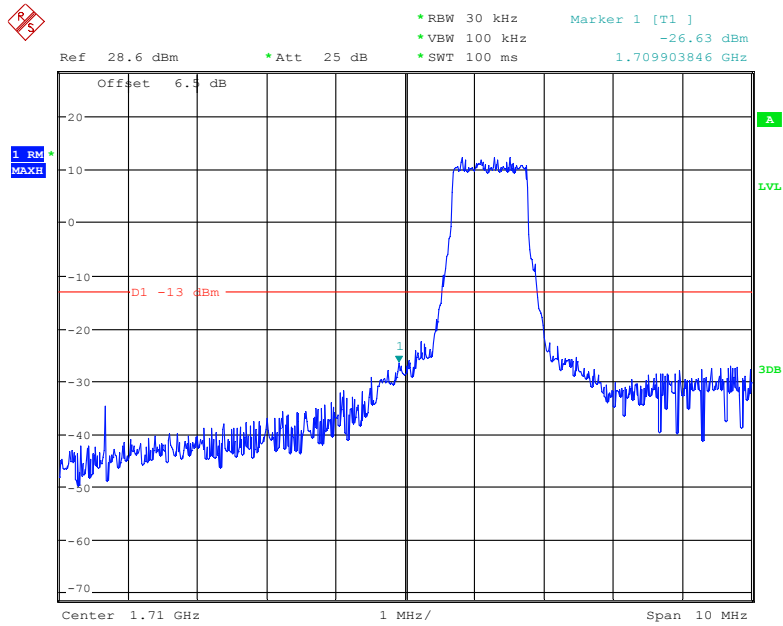

Date: 17.DEC.2019 16:46:22

### QPSK (10.0 MHz, FULL RB) - Right Band Edge

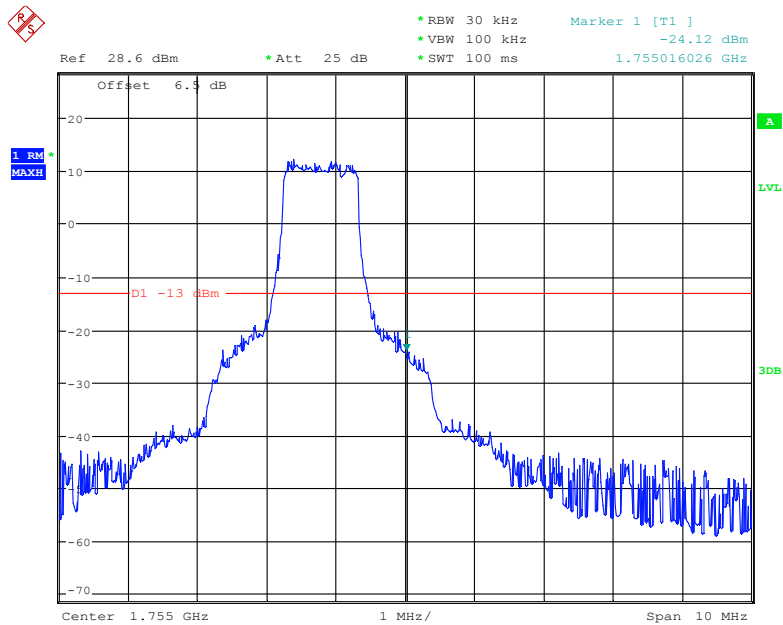

Date: 17.DEC.2019 16:50:24



### 16-QAM (10.0 MHz, FULL RB) - Left Band Edge

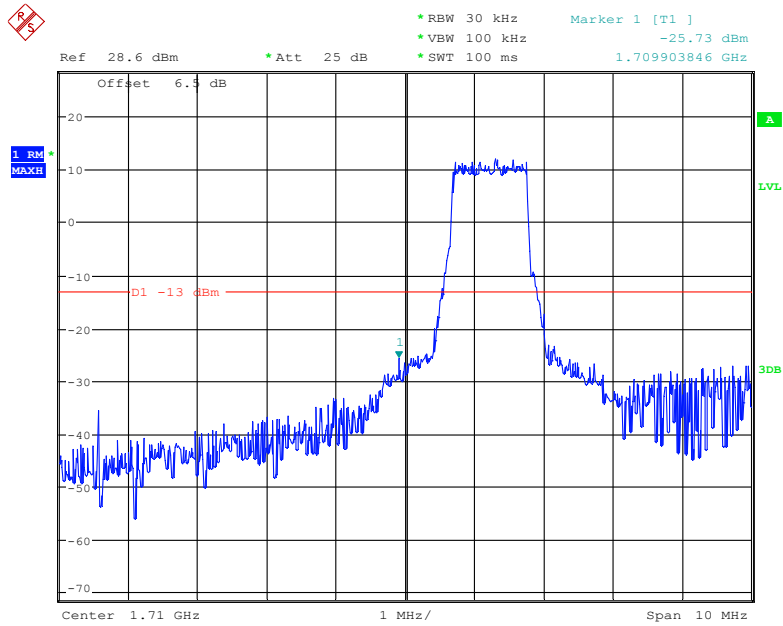

Date: 17.DEC.2019 16:47:06

### 16-QAM (10.0 MHz, FULL RB) - Right Band Edge

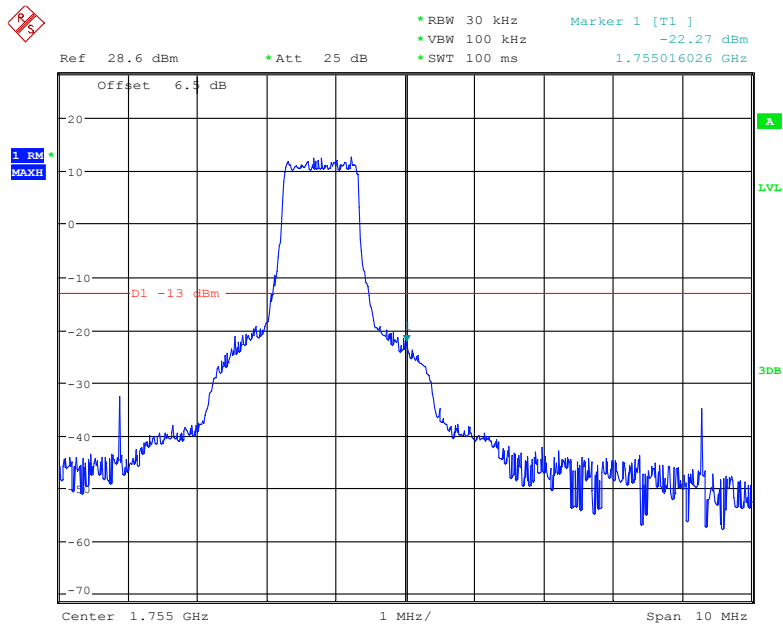

Date: 17.DEC.2019 16:49:44

### QPSK (15.0 MHz, FULL RB) - Left Band Edge

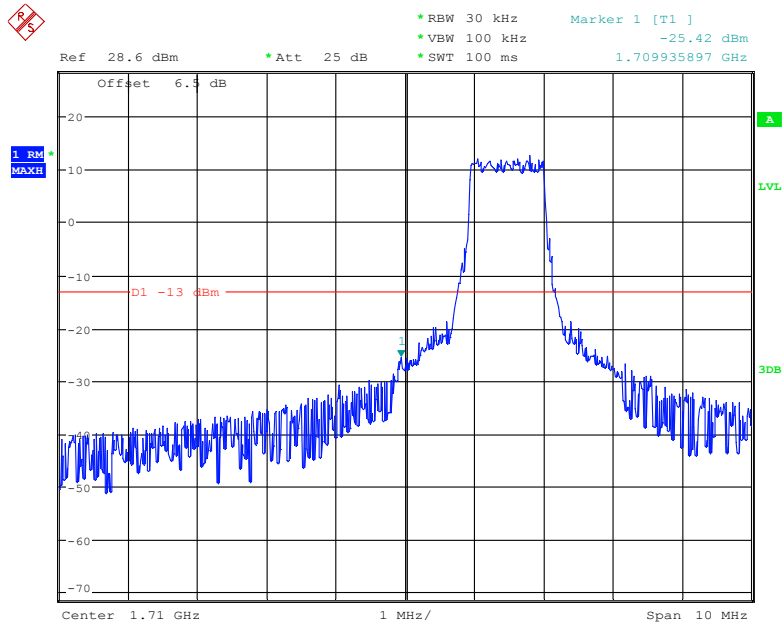

Date: 17.DEC.2019 16:33:22

### QPSK (15.0 MHz, FULL RB) - Right Band Edge

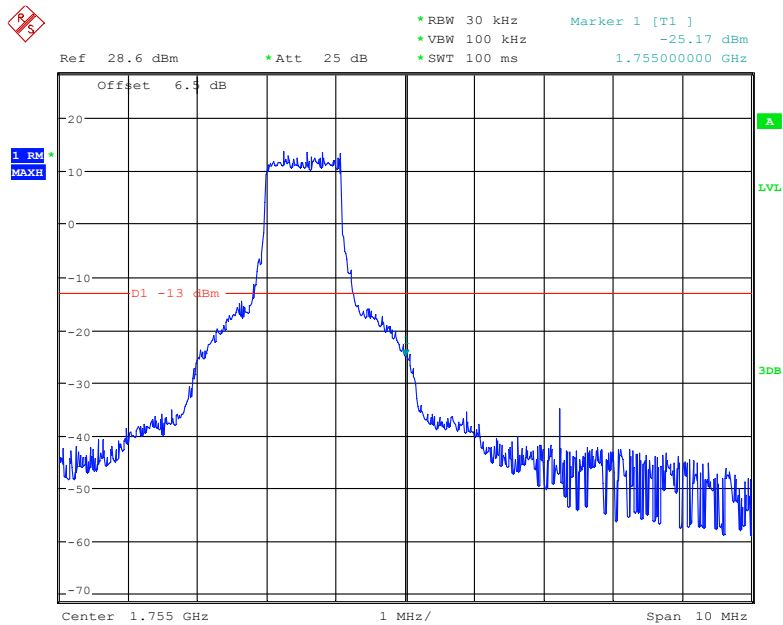

Date: 17.DEC.2019 16:37:32

### 16-QAM (15.0 MHz, FULL RB) - Left Band Edge

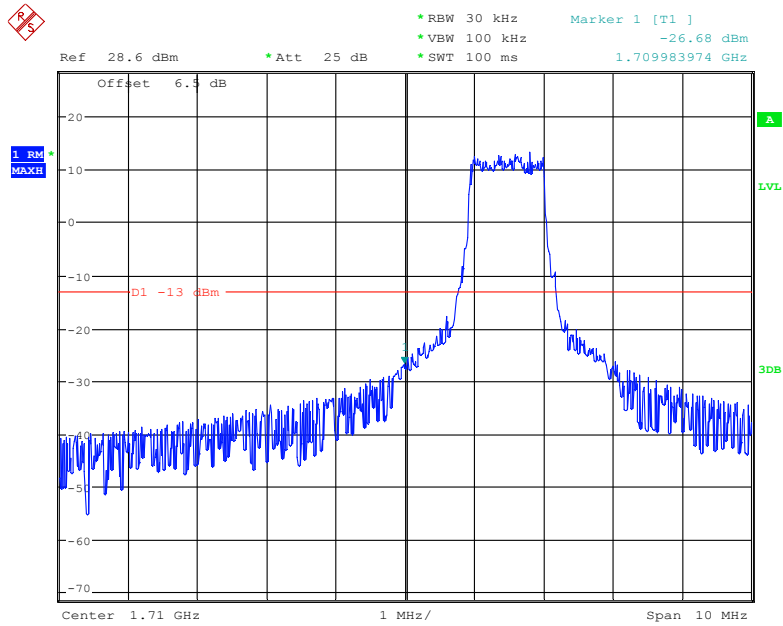

Date: 17.DEC.2019 16:34:08

### 16-QAM (15.0 MHz, FULL RB) - Right Band Edge

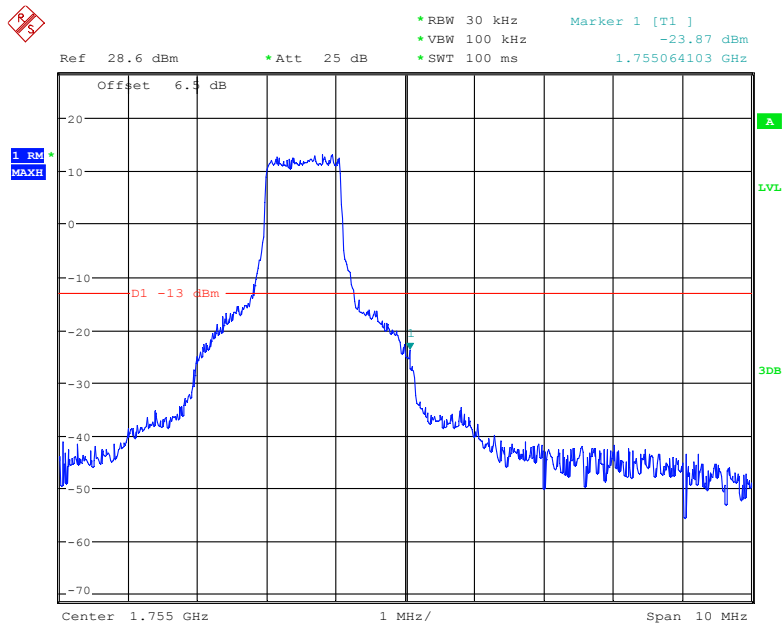

Date: 17.DEC.2019 16:38:13

### QPSK (20.0 MHz, FULL RB) - Left Band Edge

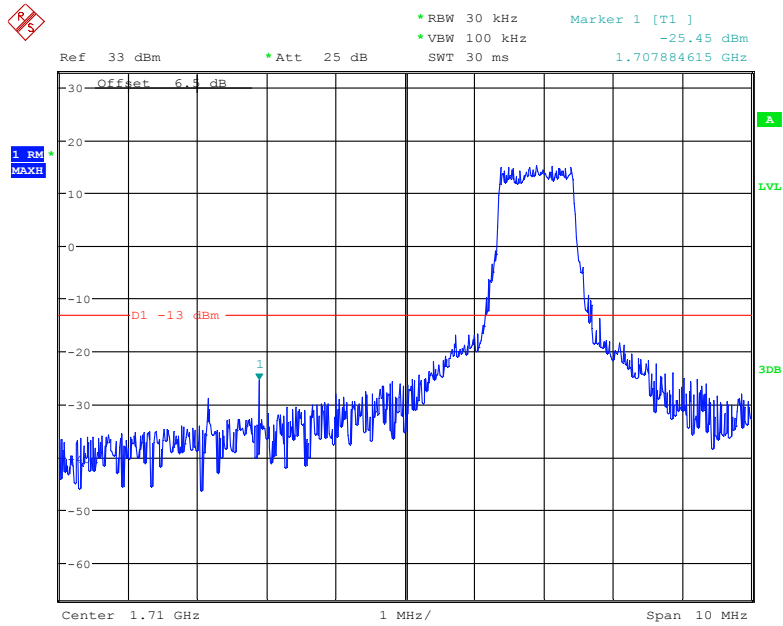

Date: 17.DEC.2019 16:16:58

### QPSK (20.0 MHz, FULL RB) - Right Band Edge

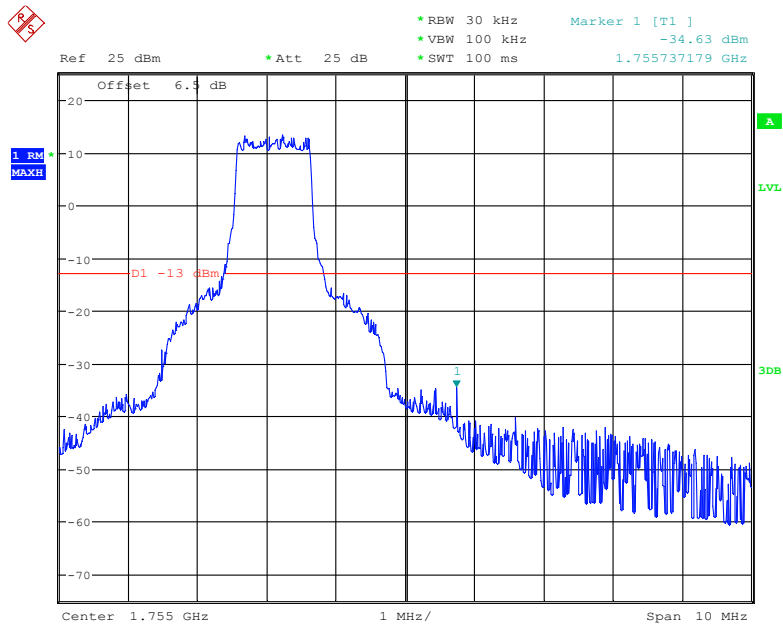

Date: 17.DEC.2019 16:28:26

### 16-QAM (20.0 MHz, FULL RB) - Left Band Edge

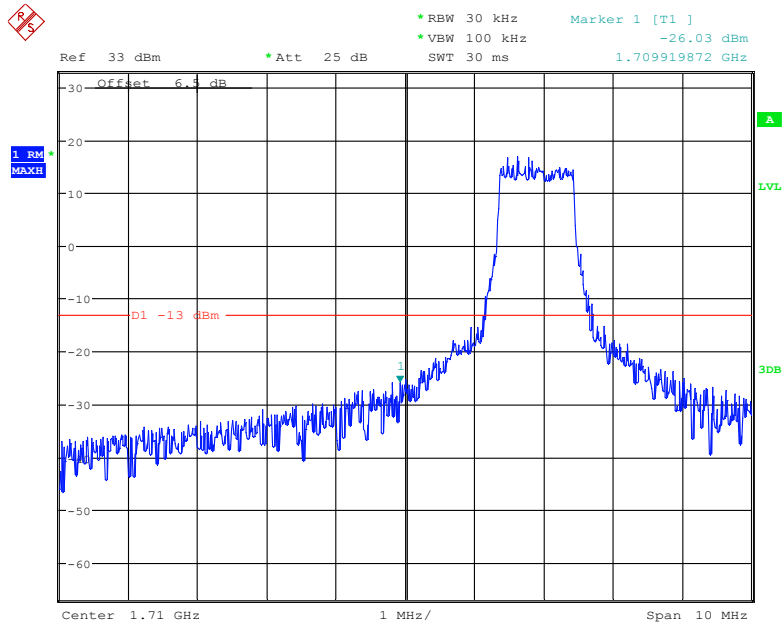

Date: 17.DEC.2019 16:16:04

### 16-QAM (20.0 MHz, FULL RB) - Right Band Edge

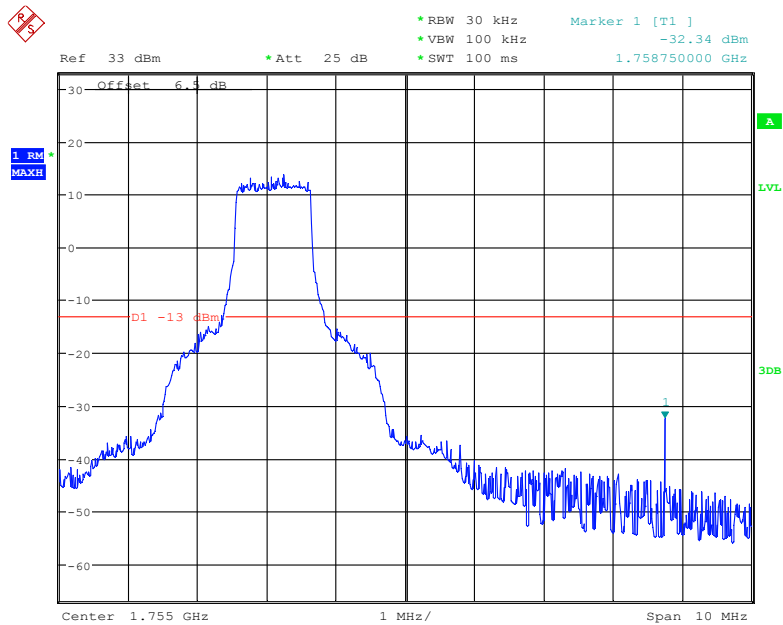

Date: 17.DEC.2019 16:20:32

**Band 12:**

**QPSK (5.0 MHz, FULL RB) - Left Band Edge**

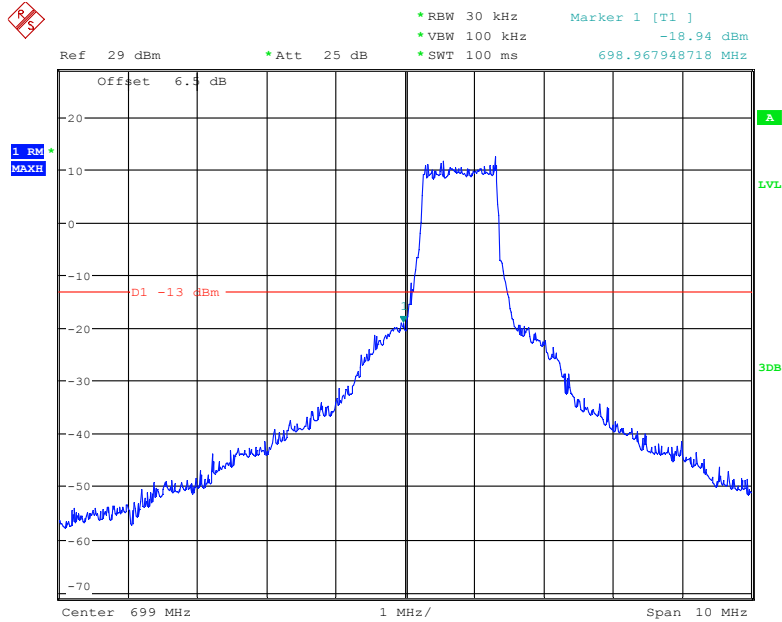

Date: 17.DEC.2019 15:17:05

**QPSK (5.0 MHz, FULL RB) - Right Band Edge**

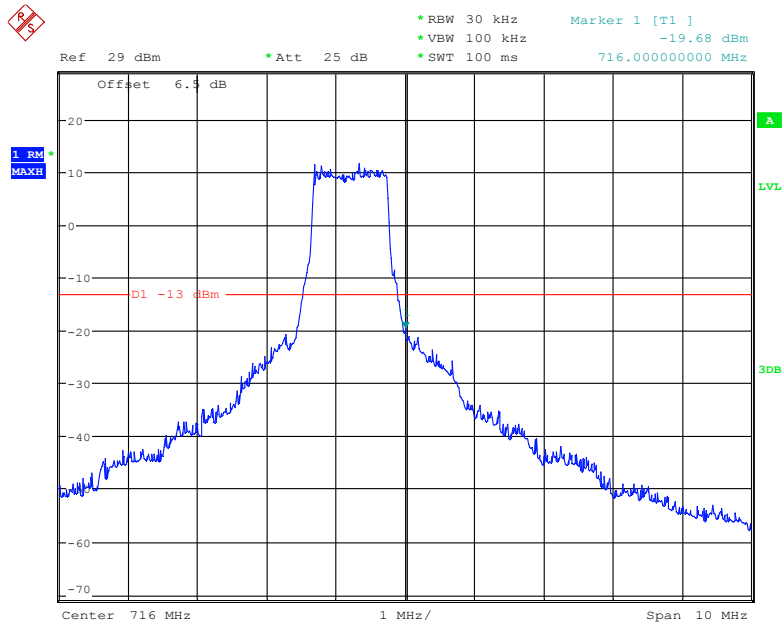

Date: 17.DEC.2019 15:19:21

### 16-QAM (5.0 MHz, FULL RB) - Left Band Edge

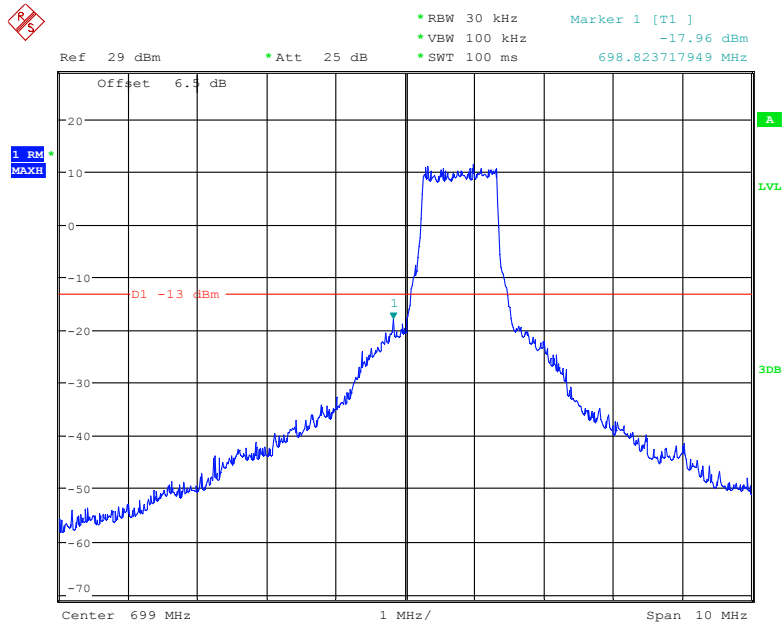

Date: 17.DEC.2019 15:17:31

### 16-QAM (5.0 MHz, FULL RB) - Right Band Edge

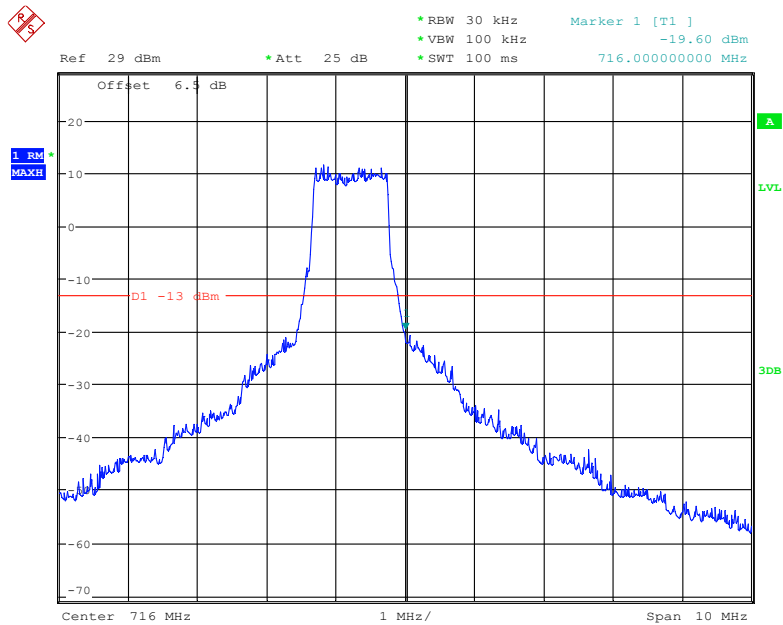

Date: 17.DEC.2019 15:18:53

### QPSK (10.0 MHz, FULL RB) - Left Band Edge

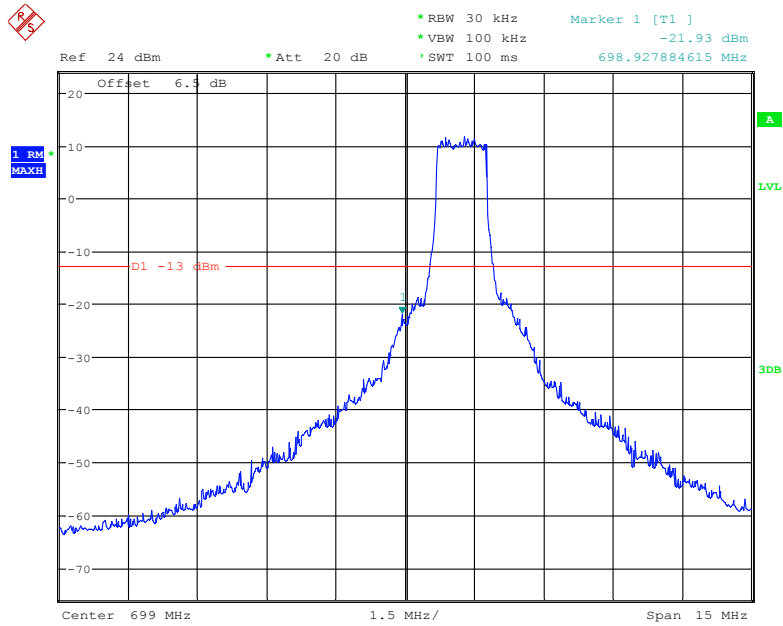

Date: 17.DEC.2019 15:03:01

### QPSK (10.0 MHz, FULL RB) - Right Band Edge

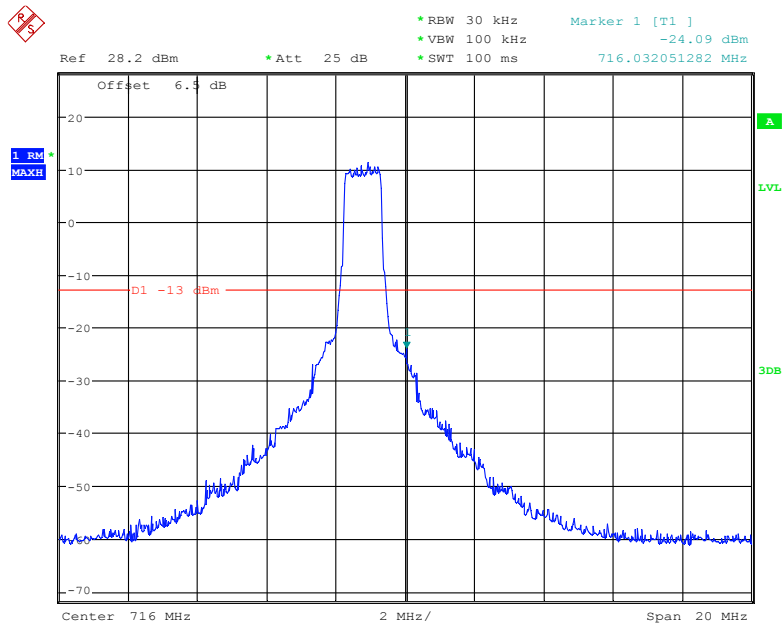

Date: 17.DEC.2019 15:06:58



### 16-QAM (10.0 MHz, FULL RB) - Left Band Edge

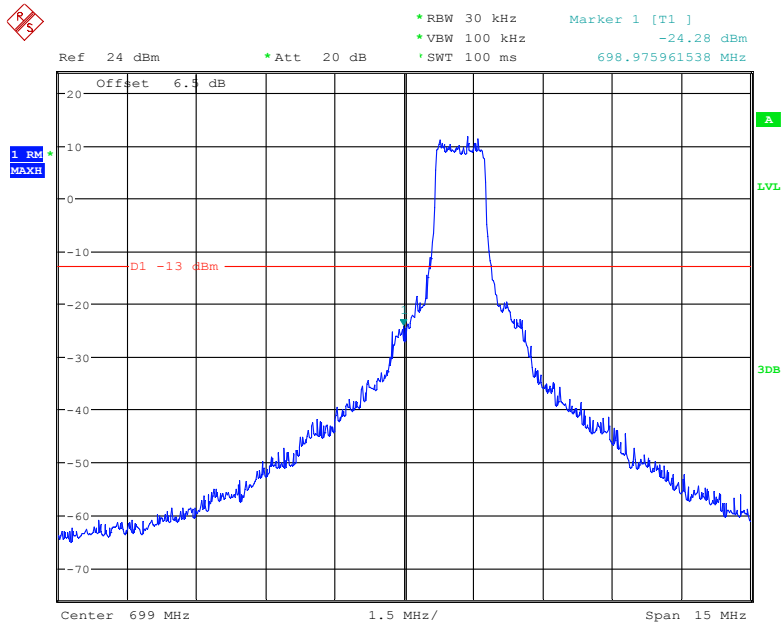

Date: 17.DEC.2019 15:04:23

### 16-QAM (10.0 MHz, FULL RB) - Right Band Edge

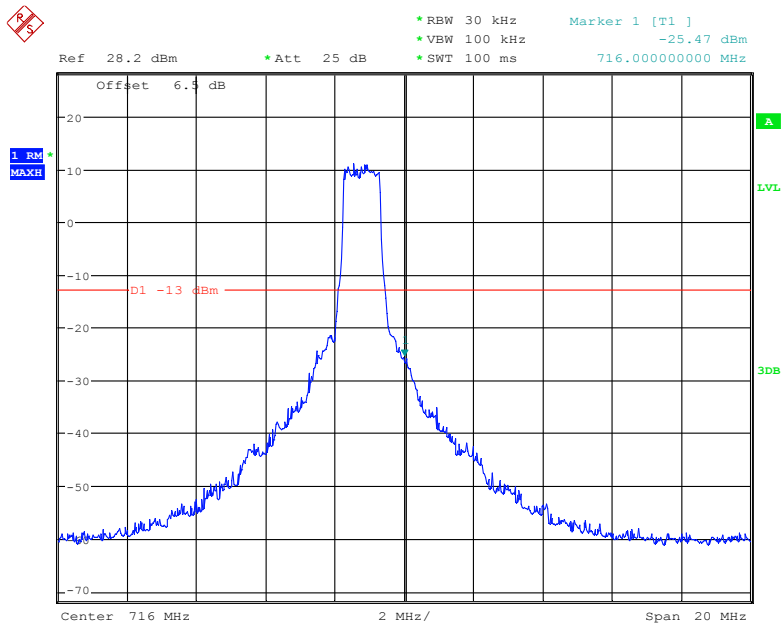

Date: 17.DEC.2019 15:07:36

**Band 13:**

**QPSK (5.0 MHz, FULL RB) - Left Band Edge**

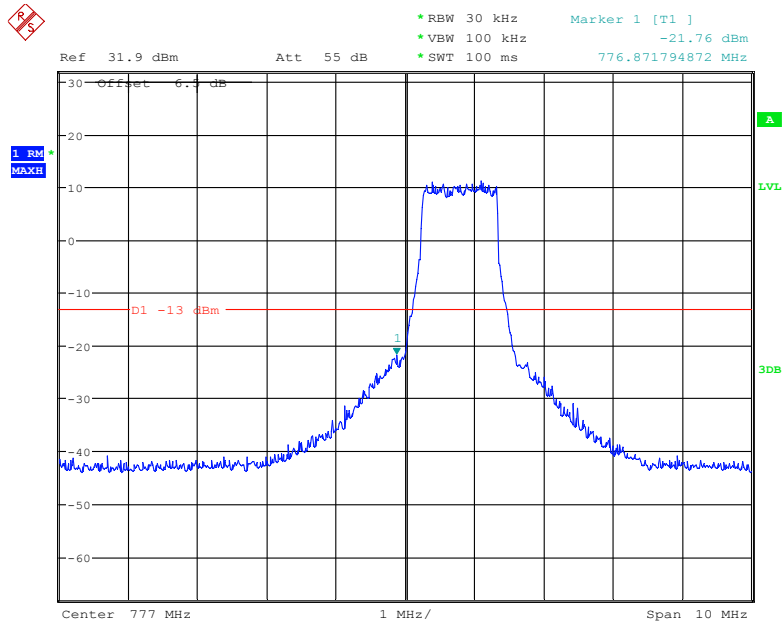

Date: 17.DEC.2019 14:34:50

**QPSK (5.0 MHz, FULL RB) - Right Band Edge**

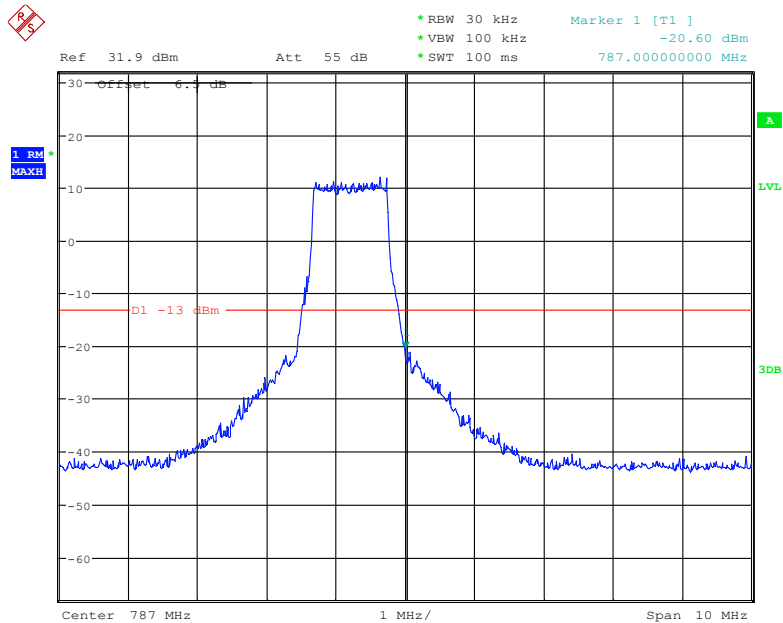

Date: 17.DEC.2019 14:36:51

### 16-QAM (5.0 MHz, FULL RB) - Left Band Edge

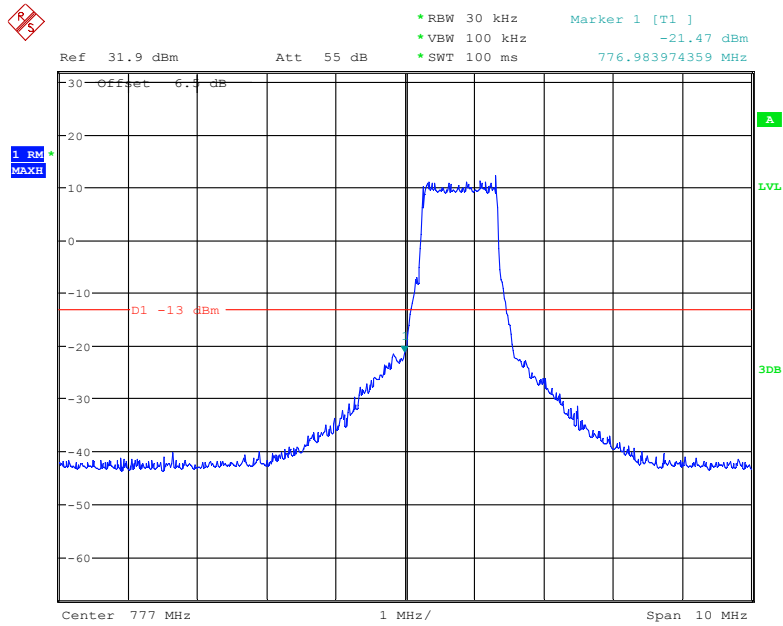

Date: 17.DEC.2019 14:34:14

### 16-QAM (5.0 MHz, FULL RB) - Right Band Edge

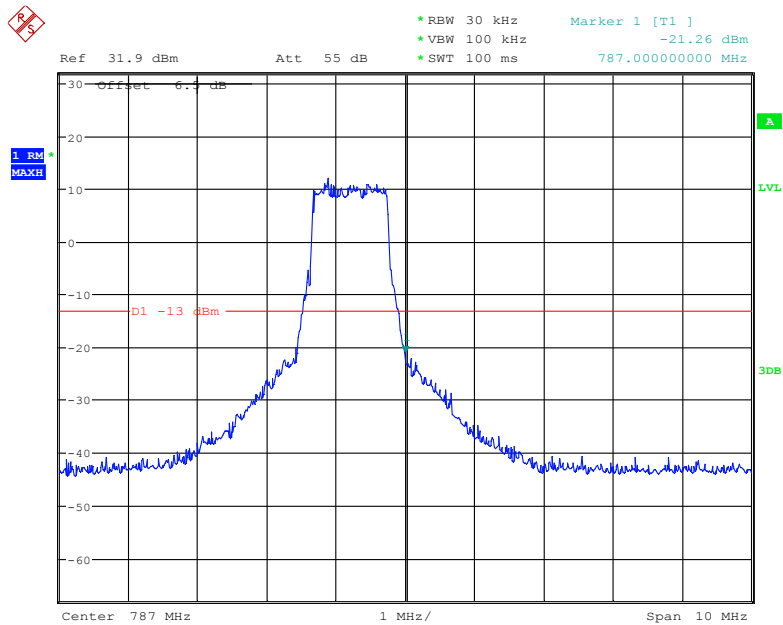

Date: 17.DEC.2019 14:37:24

### QPSK (10.0 MHz, FULL RB) - Left Band Edge

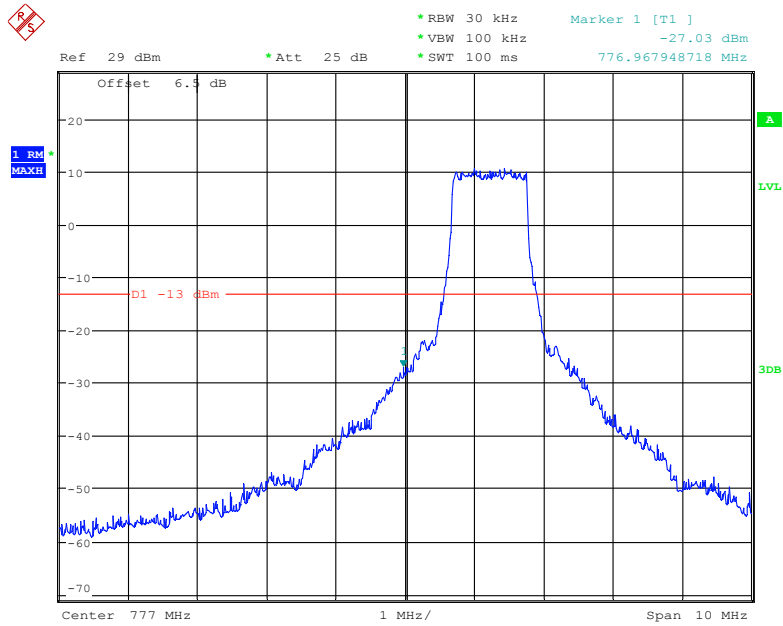

Date: 17.DEC.2019 15:22:42

### QPSK (10.0 MHz, FULL RB) - Right Band Edge

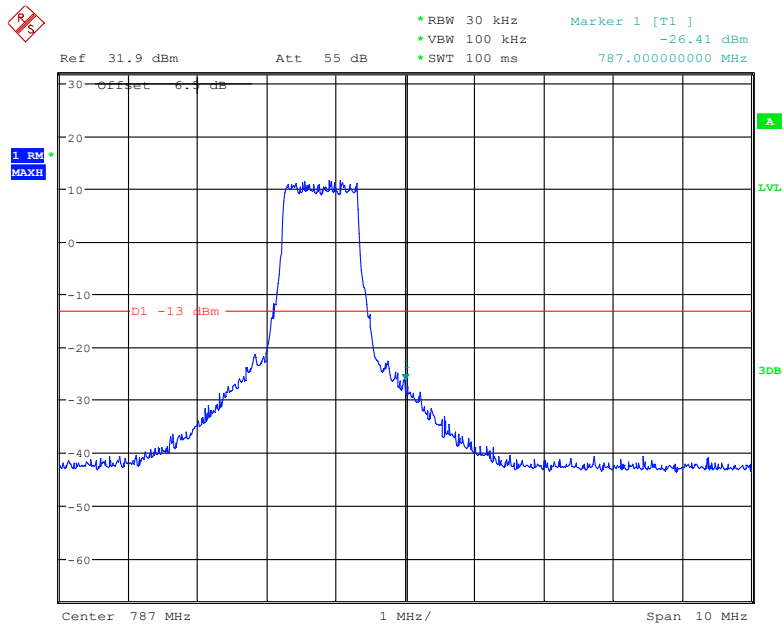

Date: 17.DEC.2019 14:44:36

### 16-QAM (10.0 MHz, FULL RB) - Left Band Edge

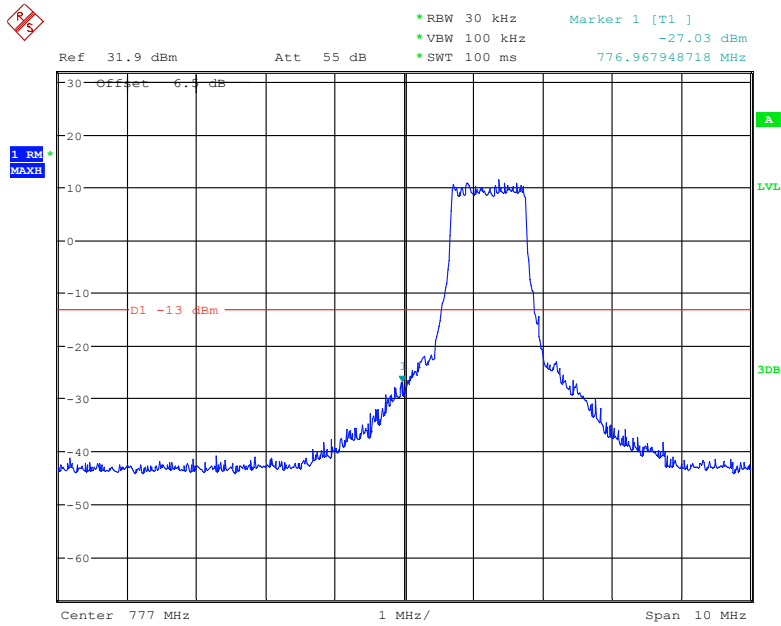

Date: 17.DEC.2019 14:42:13

### 16-QAM (10.0 MHz, FULL RB) - Right Band Edge

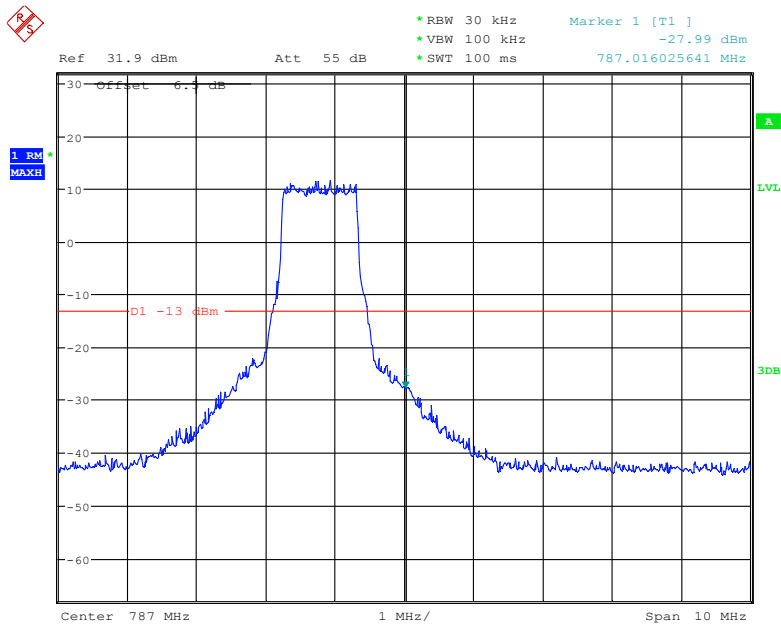

Date: 17.DEC.2019 14:45:19

## FCC § 2.1055; § 24.235; §27.54 - FREQUENCY STABILITY

### Applicable Standard

FCC § 2.1055, §24.235 and & §27.54.

According to FCC §2.1055, the frequency stability shall be sufficient to ensure that the fundamental emissions stay within the authorized bands of operation.

According to §24.235, the frequency stability shall be sufficient to ensure that the fundamental emissions stays within the authorized frequency block.

### Test Procedure

Frequency Stability vs. Temperature: The equipment under test was connected to an external DC power supply and the RF output was connected to communication test set via feed-through attenuators. The EUT was placed inside the temperature chamber. The DC leads and RF output cable exited the chamber through an opening made for the purpose.

After the temperature stabilized for approximately 20 minutes, the frequency output was recorded from the communication test set.

Frequency Stability vs. Voltage: For hand carried, battery powered equipment; reduce primary supply voltage to the battery operating end point which shall be specified by the manufacturer.

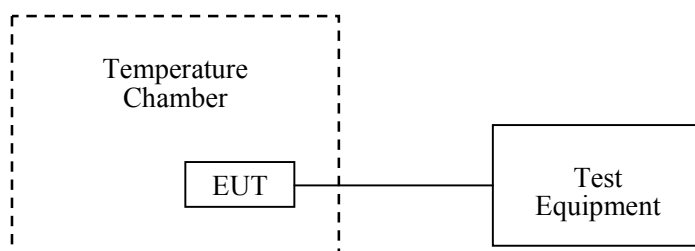

### Test Data

#### Environmental Conditions

<b>Temperature:</b>	25 °C
<b>Relative Humidity:</b>	52 %
<b>ATM Pressure:</b>	101.0 kPa

*The testing was performed by Gavin Guo on 2019-12-17.*

*EUT operation mode: Transmitting*

*Test Result: Compliance. Please refer to the following tables.*

**Band 2:**

**QPSK:**

10.0 MHz Middle Channel, $f_o=1880$ MHz				
Temperature (°C)	Power Supplied (V <sub>DC</sub> )	Frequency Error (Hz)	Frequency Error (ppm)	Result
-30	3.7	-5.13	-0.00273	pass
-20		-2.43	-0.00129	pass
-10		-3.55	-0.00189	pass
0		-4.69	-0.00249	pass
10		-4.06	-0.00216	pass
20		-3.67	-0.00195	pass
30		-3.89	-0.00207	pass
40		-4.81	-0.00256	pass
50		-5.61	-0.00298	pass
20	3.4	-2.59	-0.00138	pass
20	4.2	-6.13	-0.00326	pass

**16QAM:**

10.0 MHz Middle Channel, $f_o=1880$ MHz				
Temperature (°C)	Power Supplied (V <sub>DC</sub> )	Frequency Error (Hz)	Frequency Error (ppm)	Result
-30	3.7	-2.69	-0.00143	pass
-20		-4.39	-0.00234	pass
-10		-1.99	-0.00106	pass
0		-3.63	-0.00193	pass
10		-4.26	-0.00227	pass
20		-3.59	-0.00191	pass
30		-3.21	-0.00171	pass
40		-4.23	-0.00225	pass
50		-3.35	-0.00178	pass
20	3.4	-5.69	-0.00303	pass
20	4.2	-3.16	-0.00168	pass

**Band 4:**

**QPSK:**

Temperature (°C)	Power Supplied (V <sub>DC</sub> )	F <sub>L</sub> (MHz)	F <sub>H</sub> (MHz)	F <sub>L</sub> Limit (MHz)	F <sub>H</sub> Limit (MHz)
-30	3.7	1710.0341	1754.9683	1710	1755
-20		1710.0309	1754.9761	1710	1755
-10		1710.0355	1754.9717	1710	1755
0		1710.0306	1754.9814	1710	1755
10		1710.0460	1754.9764	1710	1755
20		1710.0205	1754.9765	1710	1755
30		1710.0325	1754.9722	1710	1755
40		1710.0217	1754.9644	1710	1755
50		1710.0238	1754.9775	1710	1755
20	3.4	1710.0457	1754.9675	1710	1755
	4.2	1710.0341	1754.9683	1710	1755

**16QAM:**

Temperature (°C)	Power Supplied (V <sub>DC</sub> )	F <sub>L</sub> (MHz)	F <sub>H</sub> (MHz)	F <sub>L</sub> Limit (MHz)	F <sub>H</sub> Limit (MHz)
-30	3.7	1710.0326	1754.9675	1710	1755
-20		1710.0301	1754.9669	1710	1755
-10		1710.0504	1754.9770	1710	1755
0		1710.0322	1754.9709	1710	1755
10		1710.0223	1754.9755	1710	1755
20		1710.0390	1754.9624	1710	1755
30		1710.0408	1754.9556	1710	1755
40		1710.0395	1754.9655	1710	1755
50		1710.0208	1754.9601	1710	1755
20		3.4	1710.0294	1754.9540	1710
	4.2	1710.0326	1754.9675	1710	1755



**Band 12:**

**QPSK:**

Temperature (°C)	Power Supplied (V <sub>DC</sub> )	F <sub>L</sub> (MHz)	F <sub>H</sub> (MHz)	F <sub>L</sub> Limit (MHz)	F <sub>H</sub> Limit (MHz)
-30	3.7	699.0323	715.9683	699	716
-20		699.0346	715.9824	699	716
-10		699.0264	715.9597	699	716
0		699.0463	715.9637	699	716
10		699.0320	715.9702	699	716
20		699.0261	715.9749	699	716
30		699.0330	715.9664	699	716
40		699.0367	715.9598	699	716
50		699.0333	715.9647	699	716
20	3.4	699.0318	715.9735	699	716
	4.2	699.0323	715.9683	699	716

**16QAM:**

Temperature (°C)	Power Supplied (V <sub>DC</sub> )	F <sub>L</sub> (MHz)	F <sub>H</sub> (MHz)	F <sub>L</sub> Limit (MHz)	F <sub>H</sub> Limit (MHz)
-30	3.7	699.0365	715.9681	699	716
-20		699.0214	715.9697	699	716
-10		699.0455	715.9699	699	716
0		699.0249	715.9721	699	716
10		699.0422	715.9683	699	716
20		699.0191	715.9708	699	716
30		699.0339	715.9581	699	716
40		699.0261	715.9687	699	716
50		699.0355	715.9852	699	716
20		3.4	699.0365	715.9681	699
	4.2	699.0282	715.9558	699	716

**Band 13:**

**QPSK:**

Temperature (°C)	Power Supplied (V <sub>DC</sub> )	F <sub>L</sub> (MHz)	F <sub>H</sub> (MHz)	F <sub>L</sub> Limit (MHz)	F <sub>H</sub> Limit (MHz)
-30	3.7	777.0341	786.9659	777	787
-20		777.0313	786.9531	777	787
-10		777.0247	786.9703	777	787
0		777.0483	786.9546	777	787
10		777.0342	786.9604	777	787
20		777.0393	786.9806	777	787
30		777.0370	786.9565	777	787
40		777.0264	786.9703	777	787
50		777.0291	786.9606	777	787
20	3.4	777.0375	786.9593	777	787
	4.2	777.0341	786.9659	777	787

**16QAM:**

Temperature (°C)	Power Supplied (V <sub>DC</sub> )	F <sub>L</sub> (MHz)	F <sub>H</sub> (MHz)	F <sub>L</sub> Limit (MHz)	F <sub>H</sub> Limit (MHz)
-30	3.7	777.0329	786.9643	777	787
-20		777.0279	786.9743	777	787
-10		777.0338	786.9619	777	787
0		777.0427	786.9600	777	787
10		777.0323	786.9699	777	787
20		777.0324	786.9703	777	787
30		777.0259	786.9739	777	787
40		777.0299	786.9718	777	787
50		777.0270	786.9576	777	787
20		3.4	777.0424	786.9705	777
	4.2	777.0329	786.9643	777	787

**\*\*\*\*\* END OF REPORT \*\*\*\*\***