

# TEST REPORT

**REPORT NUMBER: I12GWD116-2G**

**ON**

**Type of Equipment: GSM/WCDMA mobile phone**

**Model of Equipment: V32-3G**

**Marketing Name: V32-3G**

**Applicant: Emporia Telecom USA Inc.**

**China Telecommunication Technology Labs**

*Month date, year*

*April 1<sup>st</sup>, 2012*

*Signature*

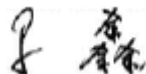
A handwritten signature in black ink, appearing to be the name 'Ma Xin' in Chinese characters.

*Ma Xin*

*Vice Director*

**FCC ID:** ZVP-V32-3G  
**IC ID:** 10262A-V32-3G  
**Report Date:** 2012-04-01

**Test Firm Name:** China Telecommunication Technology Labs  
**Registration Number:** 840587

#### Statement

The measurements shown in this report were made in accordance with the procedures described on test pages. All reported tests were carried out on a sample equipment to demonstrate limited compliance with FCC CFR 47 Parts 2, 22, and 24. The sample tested was found to comply with the requirements defined in the applied rules.

## CONTENTS

<b>1 GENERAL INFORMATION .....</b>	<b>4</b>
1.1 NOTES .....	4
1.2 TESTERS .....	5
1.3 TESTING LABORATORY INFORMATION .....	6
1.4 DETAILS OF APPLICANT OR MANUFACTURER .....	7
<b>2 TEST ITEM .....</b>	<b>8</b>
2.1 GENERAL INFORMATION.....	8
2.2 OUTLINE OF EUT .....	8
2.3 MODIFICATIONS INCORPORATED IN EUT.....	8
2.4 EQUIPMENT CONFIGURATION .....	8
2.5 OTHER INFORMATION .....	9
<b>3 SUMMARY OF TEST RESULTS.....</b>	<b>10</b>
<b>4 TEST RESULTS OF MODE .....</b>	<b>12</b>
4.1 RADIATED SPURIOUS EMISSION.....	12
4.2 OUTPUT POWER.....	17
4.3 CONDUCTED EMISSION.....	23
4.4 OCCUPIED BANDWIDTH .....	26
4.5 EMISSION BANDWIDTH .....	38
4.6 FREQUENCY STABILITY .....	50
4.7 CONDUCTED SPURIOUS EMISSION.....	56
4.8 BAND EDGE COMPLIANCE.....	67
4.9 RECEIVER RADIATED EMISSION .....	75
<b>5 TEST EQUIPMENTS AND ANCILLARIES USED FOR TESTS .....</b>	<b>78</b>
5.1 TEST EQUIPMENTS FOR RF TEST .....	78
5.2 TEST EQUIPMENTS FOR RSE TEST .....	79
<b>ANNEX A EXTERNAL PHOTOS .....</b>	<b>80</b>
<b>ANNEX B DEVIATIONS FROM PRESCRIBED TEST METHODS .....</b>	<b>82</b>

## 1 General Information

### 1.1 Notes

All reported tests were carried out on a sample equipment to demonstrate limited compliance with FCC CFR 47 Parts 2, 22 and 24.

The test results of this test report relate exclusively to the item(s) tested as specified in section 2.

The following deviation from, additions to, or exclusions from the test specifications have been made. See Annex C.

China Telecommunication Technology Labs.(CTTL) authorizes the applicant or manufacturer (see section 1.4) to reproduce this report provided, and the test report may only be reproduced or published in full. Reproduction or publication of extracts from the report requires the prior written approval of CTTL Mr. He Guili.

Any use which a third party makes of this report, or any reliance on or decisions to be made based on it, are the responsibility of such third parties. CTTL accepts no responsibility for damages, if any, suffered by any third party as a result of decisions made or actions based on this report.

## 1.2 Testers

Name: Li Peng

Position: Engineer

Signature:

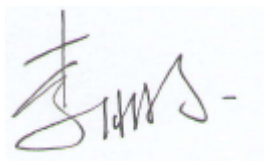

Technical responsibility for area of testing:

Name: Ma Zhiguo

Position: Manager

Date: 2012-04-01

Signature:

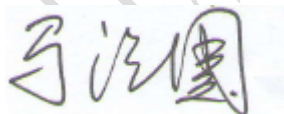

### 1.3 Testing Laboratory information

#### 1.3.1 Location

Name: China Telecommunication Technology Labs.  
Address: No. 11, Yue Tan Nan Jie, Xi Cheng District  
BEIJING  
P. R. CHINA, 100083  
Tel: +86 10 68094053  
Fax: +86 10 68011404  
Email: [emc@chinattl.com](mailto:emc@chinattl.com)

#### 1.3.2 Details of accreditation status

Accredited by: China National Accreditation Service for Conformity  
Assessment (CNAS)  
Registration number: CNAS Registration No. CNAS L0570  
Standard: ISO/IEC 17025

#### 1.3.3 Test location, where different from section 1.3.1

Name: -----  
Street: -----  
City: -----  
Country: -----  
Telephone: -----  
Fax: -----  
Postcode: -----

## 1.4 Details of applicant or manufacturer

### 1.4.1 Applicant

Name: Emporia Telecom USA Inc.  
Address: 321 E. Glen Ave, Ridgewood  
Country: United States  
Telephone: +86-134 8067 7599  
Fax: +86-755-23910530  
Contact: Clayton Wu  
Email: clayton.wu@emporia.at

### 1.4.2 Manufacturer (if different from applicant in section 1.4.1)

Name: --  
Address: --

### 1.4.3 Manufactory (if different from applicant in section 1.4.1)

Name: --  
Address: --

## 2 Test Item

### 2.1 General Information

Manufacturer: Emporia Telecom USA Inc.  
 Name: GSM/WCDMA mobile phone  
 Model Number: V32-3G  
 Serial Number: --  
 Production Status: Product  
 Receipt date of test item: 2012-02-28  
 Transmitter Frequency range: GSM850 : 824.2-848.8 MHz,  
 PCS1900: 1850.2-1909.8MHz  
 Receiver Frequency Range: GSM850: 869.2-893.8 MHz,  
 PCS1900: 1930.2-1989.8MHz  
 ISM Frequency Band 2400-2480MHz  
 High Voltage Level: 4.2 V  
 Nominal Voltage Level: 3.7 V  
 Low Voltage Level: 3.6 V

### 2.2 Outline of EUT

E.U.T. is a WCDMA multi-mode mobile phone.

### 2.3 Modifications Incorporated in EUT

The EUT has not been modified from what is described by the brand name and unique type identification stated above.

### 2.4 Equipment Configuration

Equipment configuration list:

Item	Generic Description	Manufacturer	Type	Serial No.	Remarks
A	handset	Emporia Telecom USA Inc.	V32-3G	--	None
B	adapter	KTEC BEIHAI	RL-V170-US	--	None
C	battery	Shenzhen Renergy Technology Co., Ltd	Li-ion	--	None



## 2.5 Other Information

(a) Modulation is GMSK for GSM and GPRS, and 8PSK for EGPRS.

(b) Version of hardware and software

HW Version: G362-MB-V0.2

SW Version: V4.5

(c) Adaptor information:

Input: 100-240VAC

Output: 5.0V 0.55A

(d) Battery information:

Nominal Voltage: 3.7 V

Capacity: 1000 mAh

CITL Test Report

### 3 Summary of Test Results

A brief summary of the tests carried out is shown as following.

<b>GSM mode:</b>			
<b>FCC Specification Clause</b>	<b>IC Specification Clause RSS-Gen and RSS-133</b>	<b>Name of Test</b>	<b>Result</b>
2.1051, 24.238, 22.917	6.5	Radiated Spurious Emission	Pass
22.913, 24.232	6.4	Output Power	Pass
15.107, 15.207	--	Conducted Emission	Pass
2.1049,22.917(b), 24.238(b)	4.1/4.6.1	Occupied Bandwidth	Pass
22.917(b), 24.238(b)	4.6.1	Emission Bandwidth	Pass
2.1055,22.355, 24.235	6.3	Frequency Stability	Pass
2.1057,22.917, 24.238	6.5	Conducted spurious emissions	Pass
22.917(b), 24.238(b)	6.5	Band Edge Compliance	Pass

<b>GPRS mode:</b>			
<b>FCC Specification Clause</b>	<b>IC Specification Clause RSS-Gen and RSS-133</b>	<b>Name of Test</b>	<b>Result</b>
2.1051, 24.238, 22.917	6.5	Radiated Spurious Emission	Pass
15.107, 15.207	--	Conducted Emission	Pass
2.1049,22.917(b), 24.238(b)	4.1/4.6.1	Occupied Bandwidth	Pass
22.917(b), 24.238(b)	4.6.1	Emission Bandwidth	Pass
2.1055,22.355, 24.235	6.3	Frequency Stability	Pass
2.1057,22.917, 24.238	6.5	Conducted spurious emissions	Pass
22.917(b), 24.238(b)	6.5	Band Edge Compliance	Pass

<b>EGPRS mode:</b>			
<b>FCC Specification Clause</b>	<b>IC Specification Clause RSS-Gen and RSS-133</b>	<b>Name of Test</b>	<b>Result</b>
2.1051, 24.238, 22.917	6.5	Radiated Spurious Emission	Pass
15.107, 15.207	--	Conducted Emission	Pass
2.1049,22.917(b), 24.238(b)	4.1/4.6.1	Occupied Bandwidth	Pass
22.917(b), 24.238(b)	4.6.1	Emission Bandwidth	Pass
2.1055,22.355, 24.235	6.3	Frequency Stability	Pass
2.1057,22.917, 24.238	6.5	Conducted spurious emissions	Pass
22.917(b), 24.238(b)	6.5	Band Edge Compliance	Pass

<b>Receiver Radiated Emission:</b>				
<b>Test Name</b>	<b>FCC Specification Clause</b>	<b>IC Specification Clause</b>		<b>Result</b>
		<b>RSS-132</b>	<b>RSS-133</b>	
Receiver Radiated Emission	15.109, 2.1053	4.6	6.6	Pass

## 4 Test Results of mode

### 4.1 Radiated Spurious Emission

<b>Specifications:</b>	2.1051, 24.238, 22.917
<b>Test conditions:</b>	Ambient Temperature:15°C-35°C Relative Humidity:30%-60% Air pressure: 86-106kPa
<b>Operation Mode</b>	TX on, channel 190 and 661
<b>Test Results:</b>	Pass

#### Limit Level Construction:

According to Part 24.238 (a), i.e., Out of band emissions. The power of any emission outside of the authorized operating frequency ranges must be attenuated below the transmitting power (P) by a factor of at least  $43 + 10 \log(P)$  dB, so the limit level is:  
 $P(\text{dBm}) - (43 + 10 \log(P)) \text{ dB} = -13\text{dBm}$

#### Limits for Radiated spurious emissions(UE)

Frequency range	Limit Level /Resolution Bandwidth
30 MHz to 20000 MHz	-13dBm/1MHz

#### Test Setup:

The EUT was placed in an anechoic chamber, see figure SP. The Wireless Communications Test Set was used to set the TX channel and power level and modulate the TX signal with different bit patterns. The test was done using an automated test system, where all test equipments were controlled by a computer.

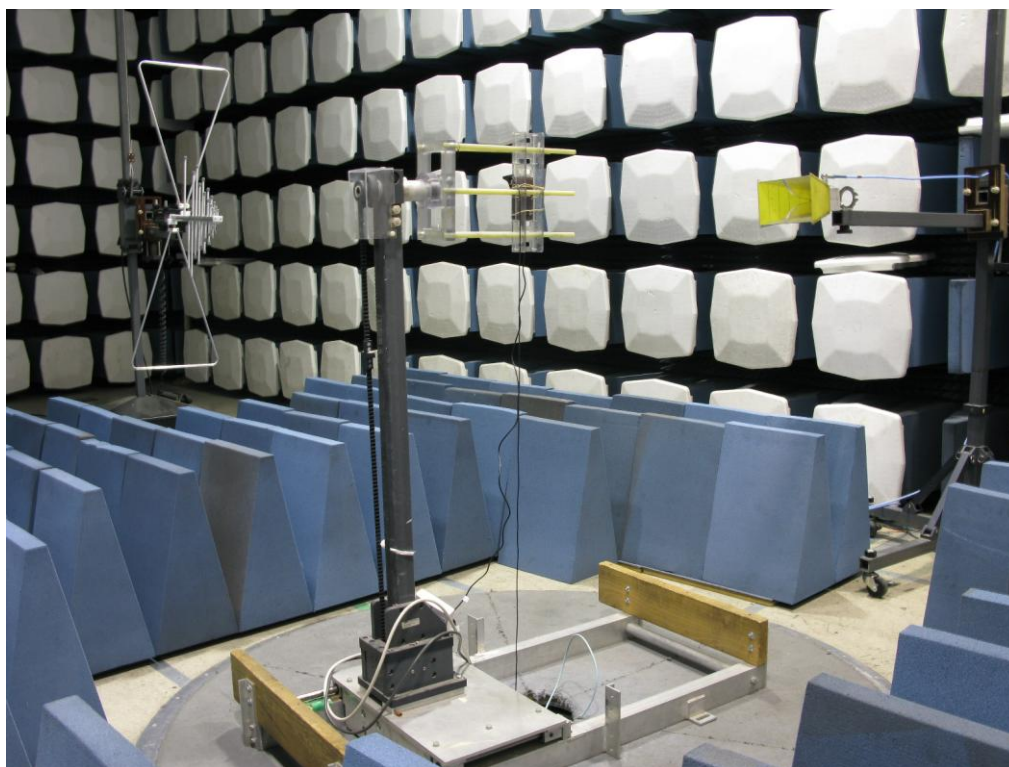

Figure SP

**Test Method:**

The measurement was performed accordance with section 2.2.12 of ANSI/TIA-603-C-2004: *Land Mobile FM or PM Communications Equipment Measurement and Performance Standards*.

- 1 The maximum spurious emissions were searched by turning the azimuth of the turntable, shifting the polarization of the measuring antenna and changing the pose of the EUT.
- 2 Levels of EUT's transmitter harmonics and suspicious signals were recorded.
- 3 The recorded levels were corrected in the automated test system with the correction factors given by a substitution calibration made before the measurement.
- 4 The corrected values of radiated spurious emissions indicated as EIRP are reported.

**Note:**

- 1 The investigated ARFCNs are 190 (836.6 MHz) and 661 (1880.0 MHz).
- 2 The investigated frequency range is 30 MHz to the 10<sup>th</sup> harmonic of the highest Frequency generated within the equipment.

Test Results for GSM mode:

GSM 850 Tx 30-3GHz-FCC Test

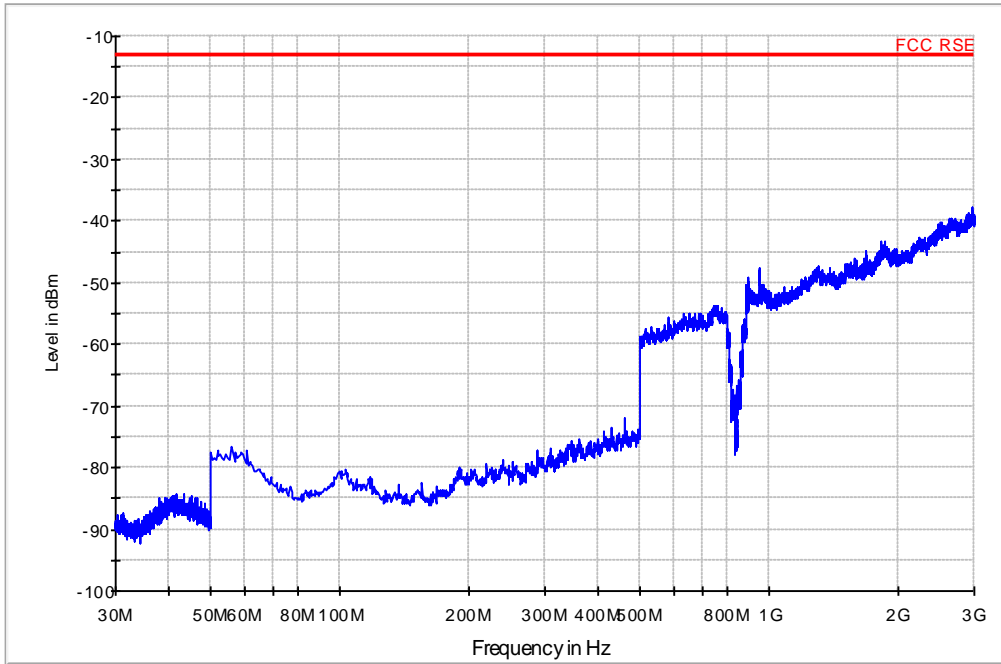

— FCC RSE Limit Line — Preview Result 1

Channel 190 for 850MHz – 30MHz to 3GHz

GSM 850 Tx 3-12.75GHz-FCC Test

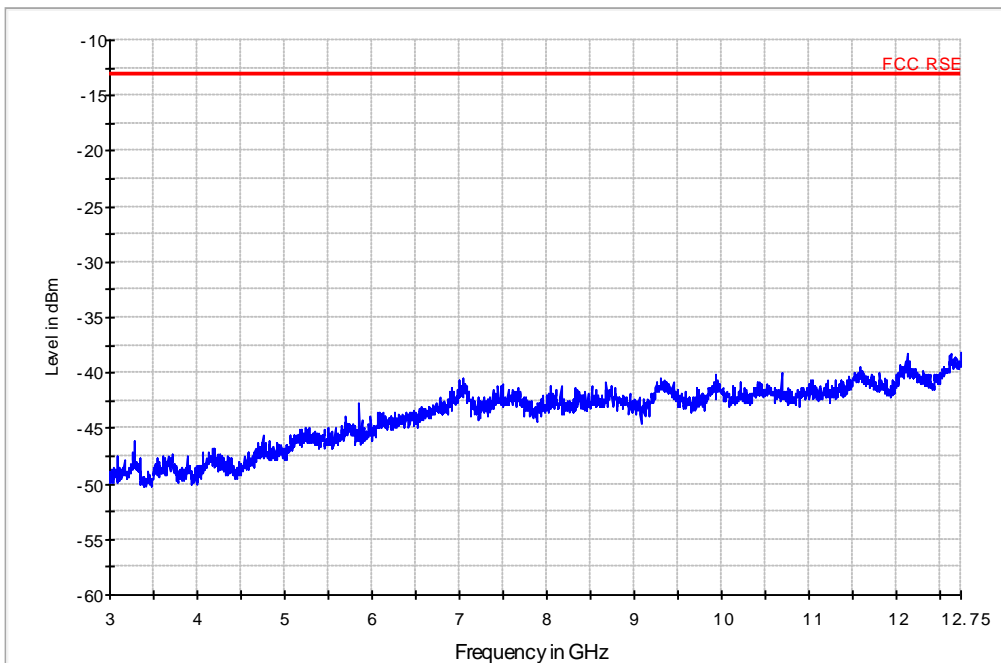

— FCC RSE Limit Line — Preview Result 1

Channel 190 for 850MHz – 3GHz to 12.75GHz

GSM 1900 T x 30-3GHz -FCC Test

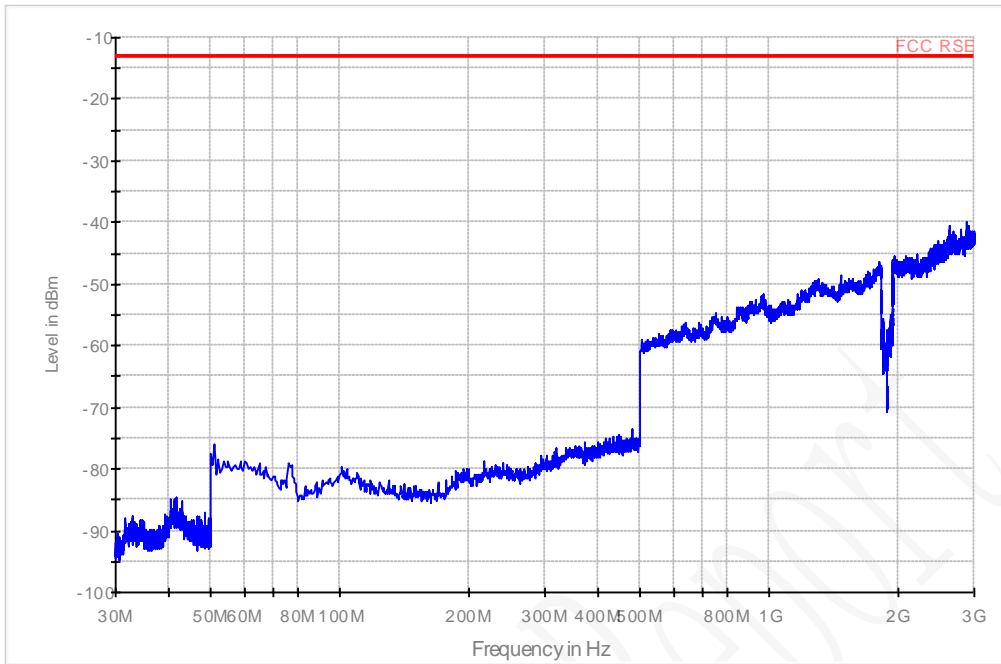

FCC RSE Limit Line      Preview Result 1

### Channel 661 for 1900MHz – Idle – 30MHz to 3GHz

GSM 1900 T x 3-20GHz -FCC Test

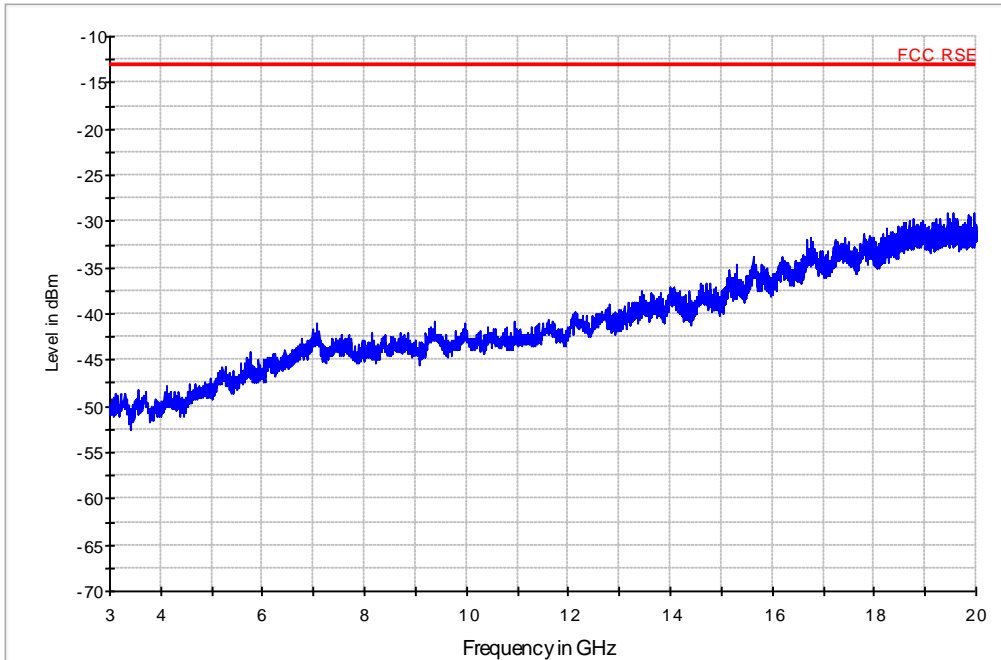

FCC RSE Limit Line      Preview Result 1

### Channel 661 for 1900MHz – Idle – 3GHz to 20GHz

GSM 1900 T x 30-3GHz -FCC Test

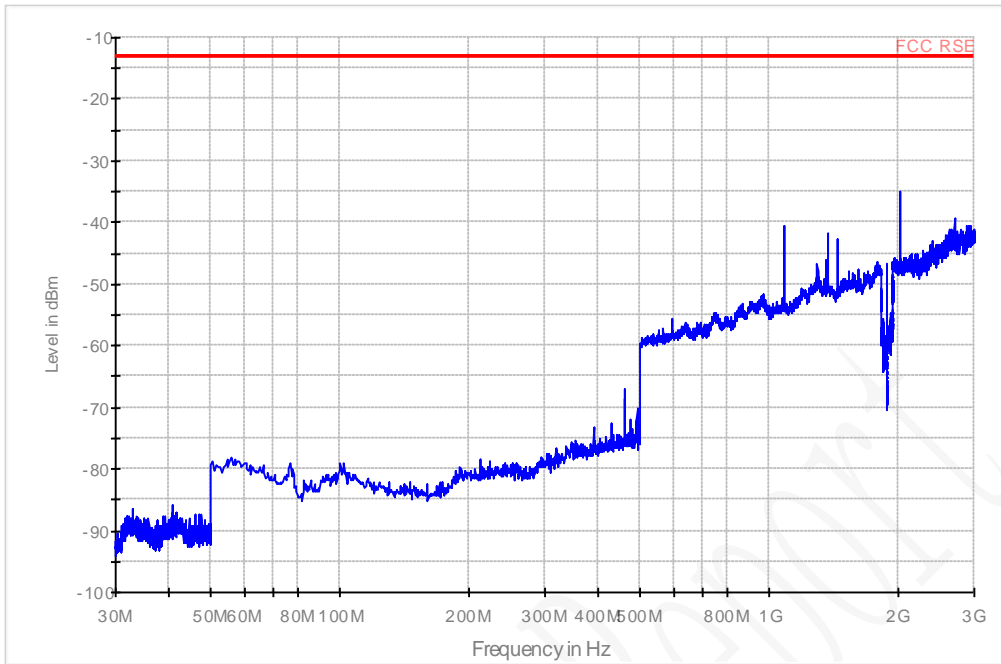

— FCC RSE LimitLine — Preview Result 1

### Channel 661 for 1900MHz– 30MHz to 3GHz

GSM 1900 T x 3-20GHz -FCC Test

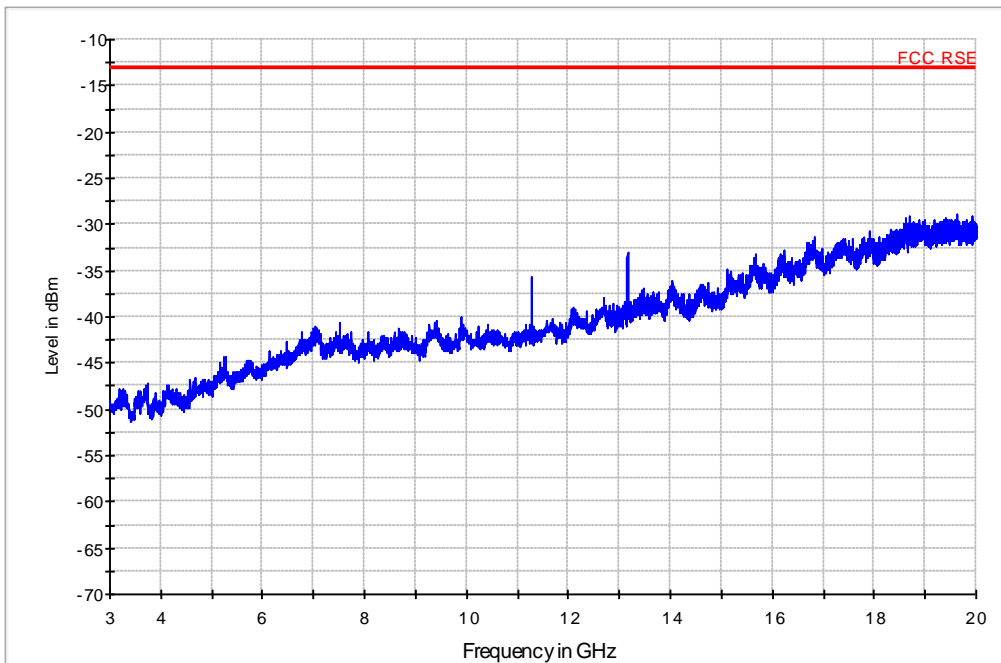

— FCC RSE LimitLine — Preview Result 1

### Channel 661 for 1900MHz– 3GHz to 20GHz



## 4.2 Output Power

### 4.2.1. Conducted Output Power

<b>Specifications:</b>	22.913, 24.232
<b>Test conditions:</b>	Ambient Temperature:15°C-35°C Relative Humidity:30%-60% Air pressure: 86-106kPa
<b>Operation Mode</b>	TX on, channel 128, 190, 251, 512, 661 and 810
<b>Test Results:</b>	Pass

#### Test Setup:

During the process of testing, the EUT was controlled via the Wireless Communications Test Set to ensure max power transmission and proper modulation and measured by Rhode & Schwarz EMI test receiver (ESI26).

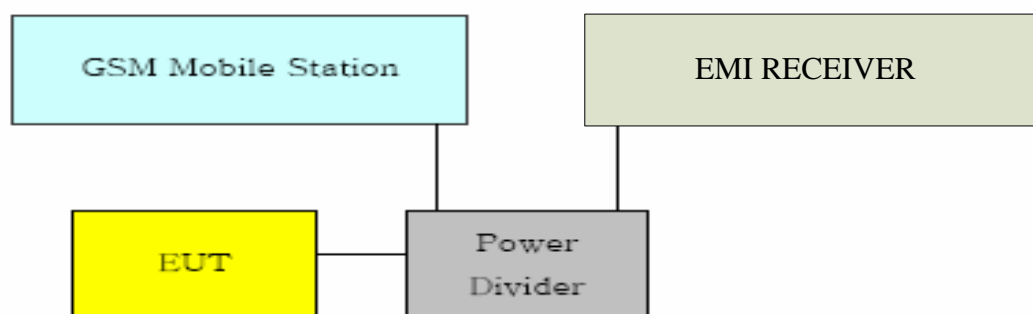

#### Test Method

- 1) The EUT was coupled to the EMI test receiver analyzer mode and the base station simulator through a power divider. The radio frequency load attached to the EUT antenna terminal was 50 Ohm. The loss of the cables the test system is calibrated to correct the readings.
- 2) The spectrum analyzer was set to Max-peak Detector function and Maximum hold mode.
- 3) The resolution bandwidth of the spectrum analyzer was comparable to the emission bandwidth.

**Note: --**

**Test Result for GSM mode:**

**GSM 850 band:**

**Limit**

	Nominal Peak Output Power [dBm]
GSM	33 (2W)
GPRS	33 (2W)
EGPRS	27 (0.5W)

**GSM**

ARFCN	Output Power [dBm]
128	32.02
190	31.91
251	31.74

**GPRS**

ARFCN	Output Power [dBm]
128	30.92
190	30.77
251	30.63

**EGPRS**

ARFCN	Output Power [dBm]
128	30.93
190	30.77
251	30.63

**GSM 1900 band:**

**Limit**

	Nominal Peak Output Power [dBm]
GSM	30 (1W)
GPRS	30 (1W)
EGPRS	26 (0.4W)

**GSM**

ARFCN	Output Power [dBm]
512	29.56
661	29.59
810	29.35

**GPRS**

ARFCN	Output Power [dBm]
512	28.48
661	28.50
810	28.26

**EGPRS**

ARFCN	Output Power [dBm]
512	28.49
661	28.51
810	28.25

#### 4.2.2. Radiated Output Power

##### Test Setup:

The EUT was set in an anechoic chamber, which is connected to the Wireless Communications Test Set located outside the chamber over the air. The test was done using an automated test system, where all test equipments were controlled by a computer.

##### Test Method

The measurement was performed accordance with section 2.2.17 of ANSI/TIA-603-C-2004: *Land Mobile FM or PM Communications Equipment Measurement and Performance Standards*.

1 The maximum power was searched by turning the azimuth of the turntable, shifting the polarization of the measuring antenna and changing the pose of the EUT.

2 The measured levels are EIRP values corrected in the automated test system with the correction factors given by a substitution calibration made before the measurement. The calibration is made separately for vertical and horizontal polarization and the system uses different correction factors depending on the measuring antenna polarization.

3 The corrected maximum levels were reported for EIRP values, and ERP values can be calculated from EIRP values.

##### Note:

ERP dBm = EIRP dBm - 2.15dB.

**ERP Value for GSM 850 band mode:**

**Limits**

	Burst Peak ERP (dBm)
GSM	≤ 38.45 (7W)
GPRS	≤ 38.45 (7W)
EGPRS	≤ 38.45 (7W)

**GSM**

ARFCN	Frequency [MHz]	ERP [dBm]
128	824.228	25.06
190	836.553	24.62
251	848.777	24.12

**GPRS**

ARFCN	Frequency [MHz]	ERP [dBm]
128	824.128	23.91
190	836.553	24.00
251	848.777	23.60

**EGPRS**

ARFCN	Frequency [MHz]	ERP [dBm]
128	824.128	22.06
190	836.553	21.80
251	848.877	21.05

**EIRP Value for GSM 1900 band mode:**

**Limits**

	Burst Peak EIRP (dBm)
GSM	≤ 33 (2W)
GPRS	≤ 33 (2W)
EGPRS	≤ 33 (2W)

**GSM**

ARFCN	Frequency [MHz]	EIRP [dBm]
512	1850.100	29.65
661	1880.080	28.68
810	1909.739	28.85

**GPRS**

ARFCN	Frequency [MHz]	EIRP [dBm]
512	1850.100	28.47
661	1880.080	28.70
810	1909.899	28.93

**EGPRS**

ARFCN	Frequency [MHz]	EIRP [dBm]
512	1850.100	28.15
661	1879.919	27.65
810	1909.739	27.50

### 4.3 Conducted Emission

<b>Specifications:</b>	15.107, 15.207
<b>Test conditions:</b>	Ambient Temperature:15°C-35°C Relative Humidity:30%-60% Air pressure: 86-106kPa
<b>Operation Mode</b>	TX on, channel 190 and 661
<b>Test Results:</b>	Pass

#### Test Method

The Measure procedure is TIA-603-2004 is used. Conducted Emission is measured with travel charger.

#### Limit

Frequency of Emission (MHz)	Conducted Limit (dB $\mu$ V)	
	Quasi-Peak	Average
0.15 - 0.5	66 to 56*	56 to 46*
0.5 - 5	56	46
5 - 30	60	50

Note: \* Decreases with logarithm of the frequency

**Test Result**  
**GSM 850MHz**

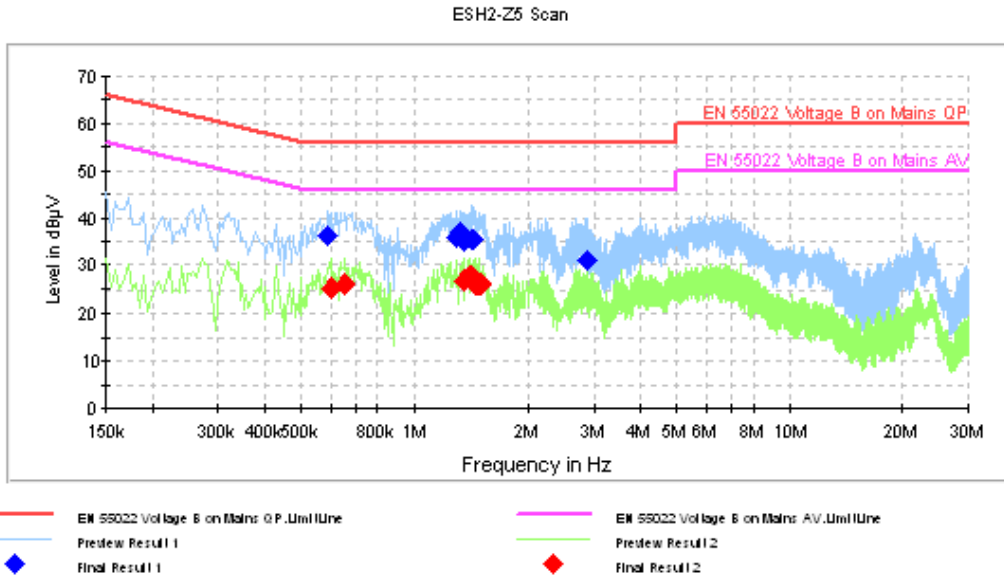

Frequency (MHz)	QuasiPeak (dB $\mu$ V)	PE	Line	Corr. (dB)	Margin (dB)	Limit (dB $\mu$ V)
0.291000	36.1	FLO	L1	10.1	19.9	56.0
1.302000	35.8	FLO	L1	10.1	20.2	56.0
1.324500	37.0	FLO	L1	10.1	19.0	56.0
1.360500	34.9	FLO	N	10.1	21.1	56.0
1.432500	35.3	FLO	N	10.1	20.7	56.0
2.859000	31.0	FLO	N	10.1	25.0	56.0

Frequency (MHz)	CAverage (dB $\mu$ V)	PE	Line	Corr. (dB)	Margin (dB)	Limit (dB $\mu$ V)
0.604500	25.3	FLO	N	10.1	20.7	46.0
0.654000	26.3	FLO	L1	10.0	19.7	46.0
1.360500	27.0	FLO	L1	10.1	19.0	46.0
1.405500	27.6	FLO	L1	10.1	18.4	46.0
1.455000	26.3	FLO	N	10.1	19.7	46.0
1.486500	26.0	FLO	N	10.1	20.0	46.0



GSM 1900MHz

ESH2-Z5 Scan

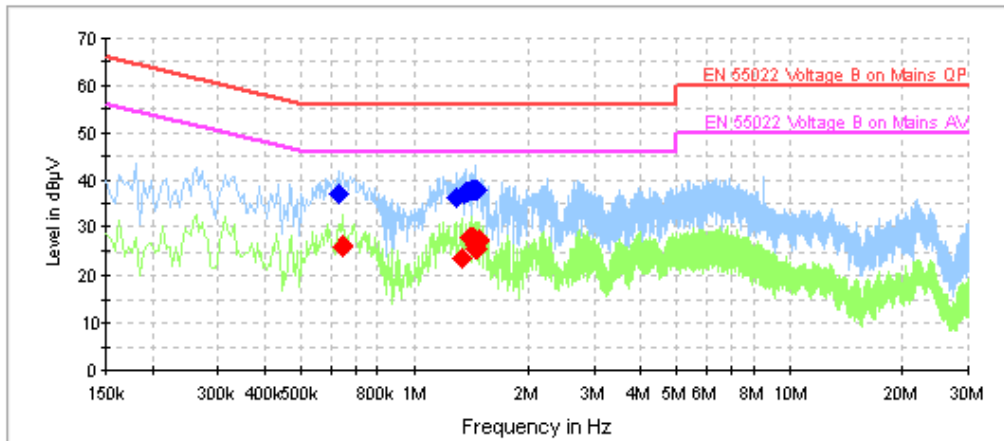

— EN 55022 Voltage B on Mains QP.Limit Line  
— EN 55022 Voltage B on Mains AV.Limit Line  
— Prewiew Result 1  
— Prewiew Result 2  
◆ Final Result 1  
◆ Final Result 2

Frequency (MHz)	QuasiPeak (dB µV)	PE	Line	Corr. (dB)	Margin (dB)	Limit (dB µV)
0.627000	36.8	FL	L1	10.0	19.2	56.0
1.302000	36.1	FL	L1	10.1	19.9	56.0
1.365000	37.2	FL	L1	10.1	18.8	56.0
1.383000	37.3	FL	L1	10.1	18.7	56.0
1.428000	37.9	FL	L1	10.1	18.1	56.0
1.459500	37.7	FL	L1	10.1	18.3	56.0

Frequency (MHz)	CAverage (dB µV)	PE	Line	Corr. (dB)	Margin (dB)	Limit (dB µV)
0.645000	26.3	FL	N	10.0	19.7	46.0
1.351500	23.7	FL	N	10.1	22.3	46.0
1.410000	27.8	FL	L1	10.1	18.2	46.0
1.428000	27.7	FL	L1	10.1	18.3	46.0
1.459500	25.9	FL	N	10.1	20.1	46.0
1.477500	27.3	FL	L1	10.1	18.7	46.0

#### 4.4 Occupied bandwidth

<b>Specifications:</b>	2.1049,22.917(b),24.238(b)
<b>Operation Mode</b>	TX on, channel 128, 190, 251, 512, 661 and 810
<b>Test Results:</b>	Pass

#### Test Setup

The situation under which maximum EIRP values were found in the measurement of the radiated RF power output was used to determine the 99% occupied bandwidth. The Wireless Communications Test Set was used to set the TX channel, power level and modulation.

#### Test Method

The 99% occupied bandwidth was calculated from the spectrum analyzer. Markers in the spectrum analyzer were then placed between the calculated frequencies to show the calculated 99% power band.

**Note: --**

#### Results data of GSM mode:

EUT channel	99% occupied bandwidth [kHz]
128	245.19
190	243.59
251	248.40
512	243.59
661	246.80
810	241.99

Graphical results for GSM mode:

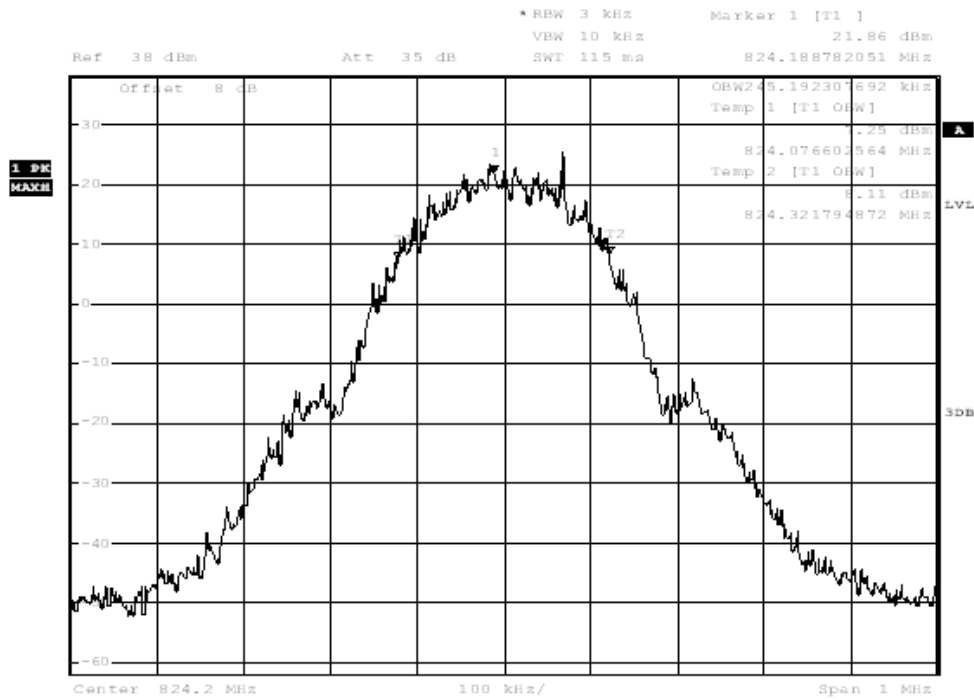

Date: 29.FEB.2012 23:47:14

Channel 128

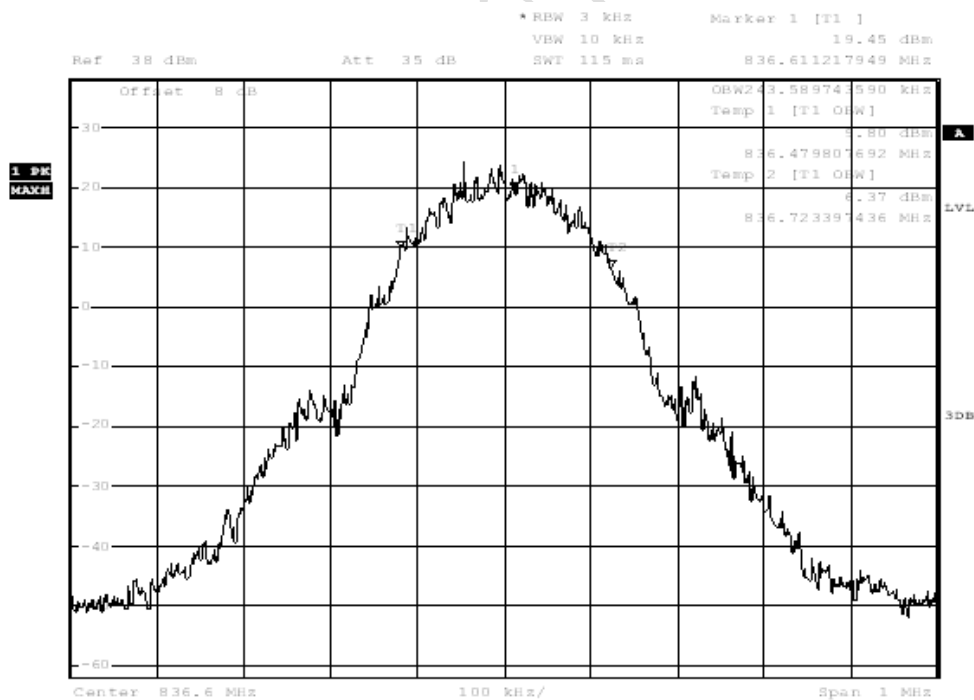

Date: 29.FEB.2012 23:47:51

Channel 190

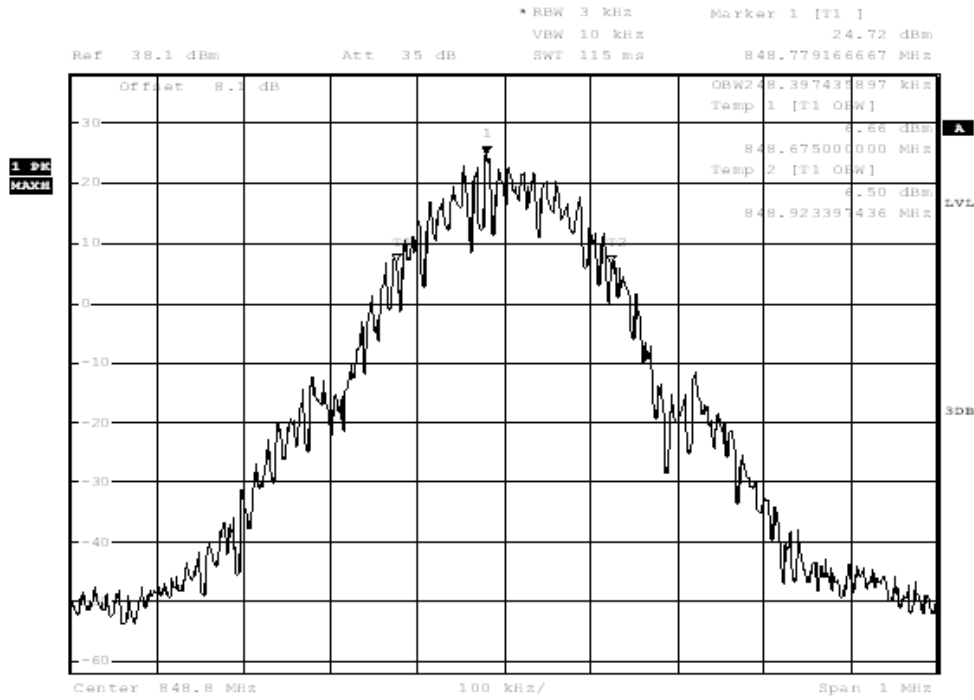

Date: 29.FEB.2012 23:48:27

### Channel 251

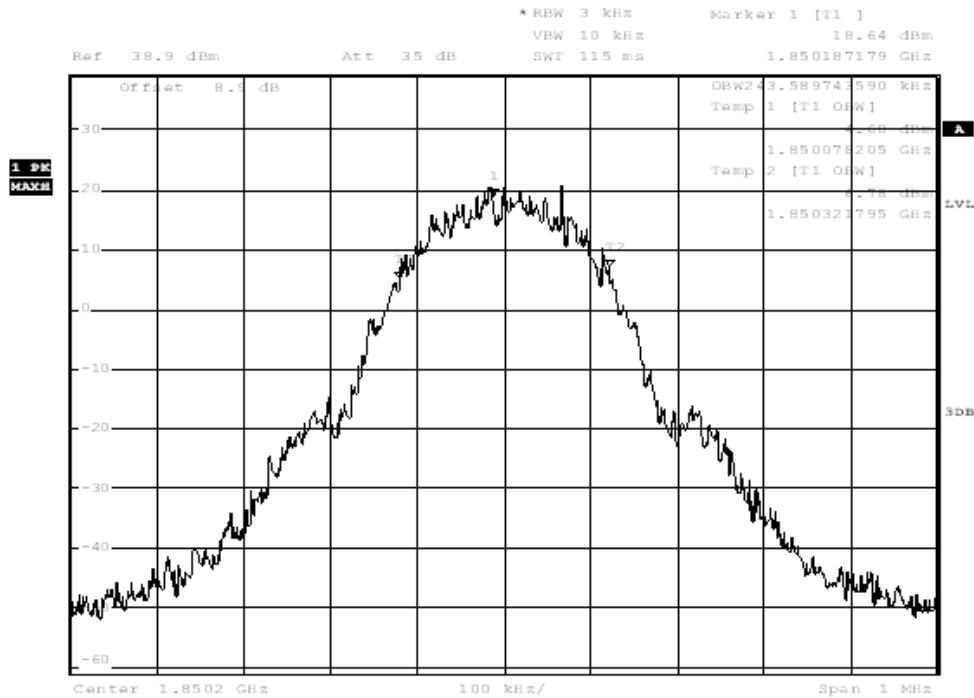

Date: 1.MAR.2012 00:19:53

### Channel 512

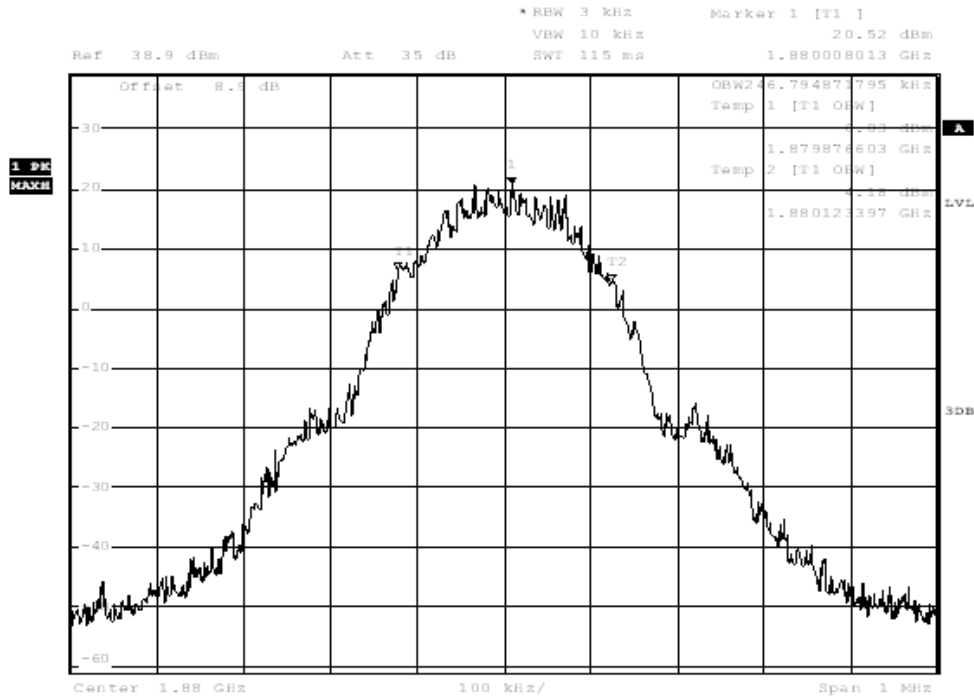

Date: 1.MAR.2012 00:20:30

### Channel 661

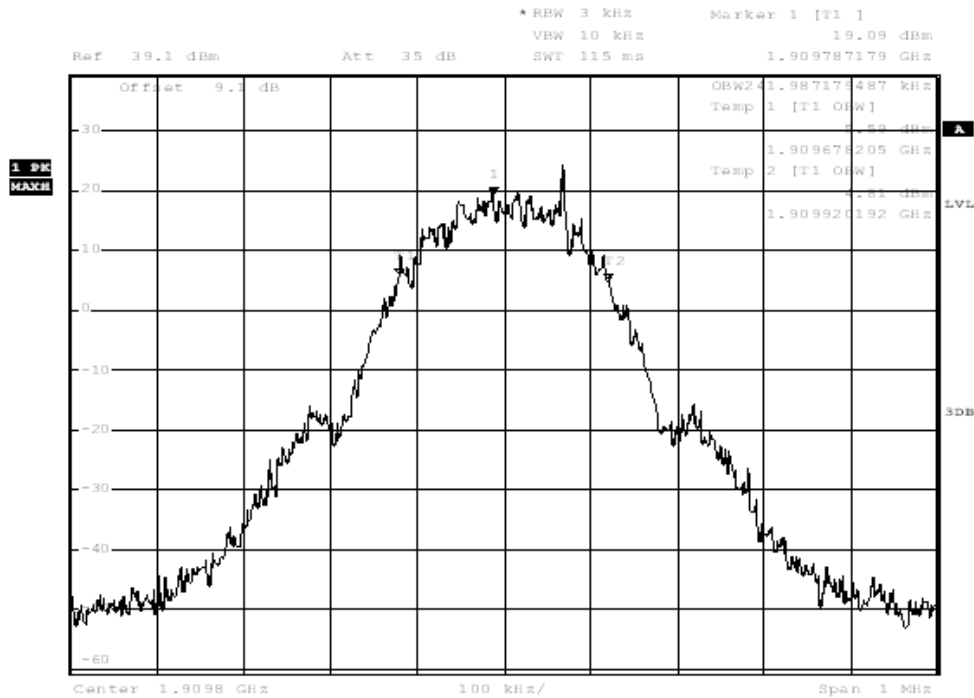

Date: 1.MAR.2012 00:21:06

### Channel 810

**Results data of GPRS mode:**

EUT channel	99% occupied bandwidth [kHz]
128	243.59
190	243.59
251	245.19
512	245.19
661	245.19
810	243.59

**Graphical results for GPRS mode:**

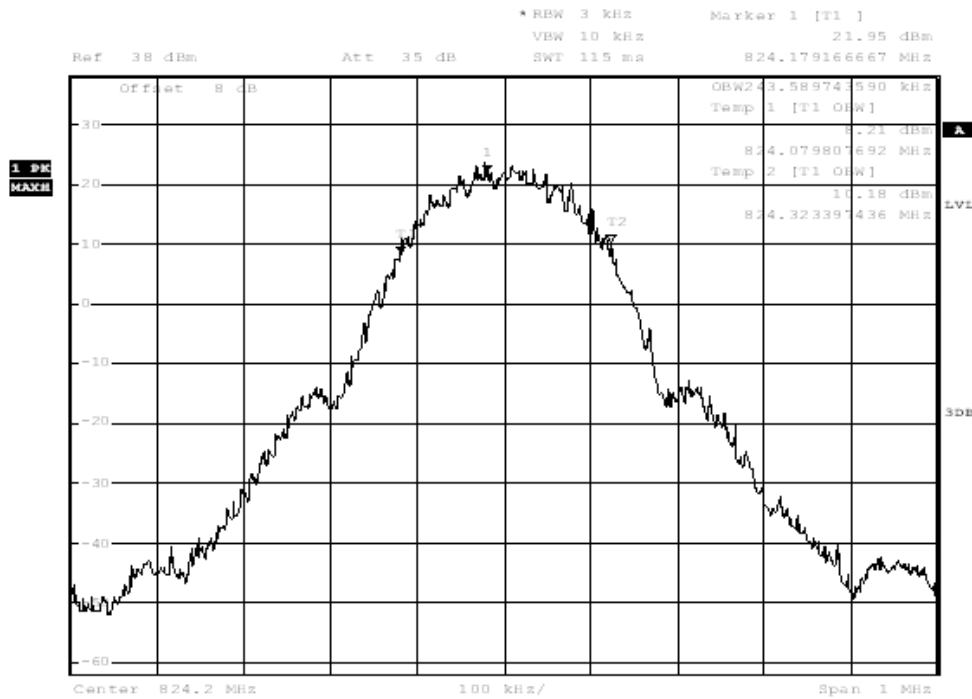

Date: 5.MAR.2012 21:54:17

**Channel 128**

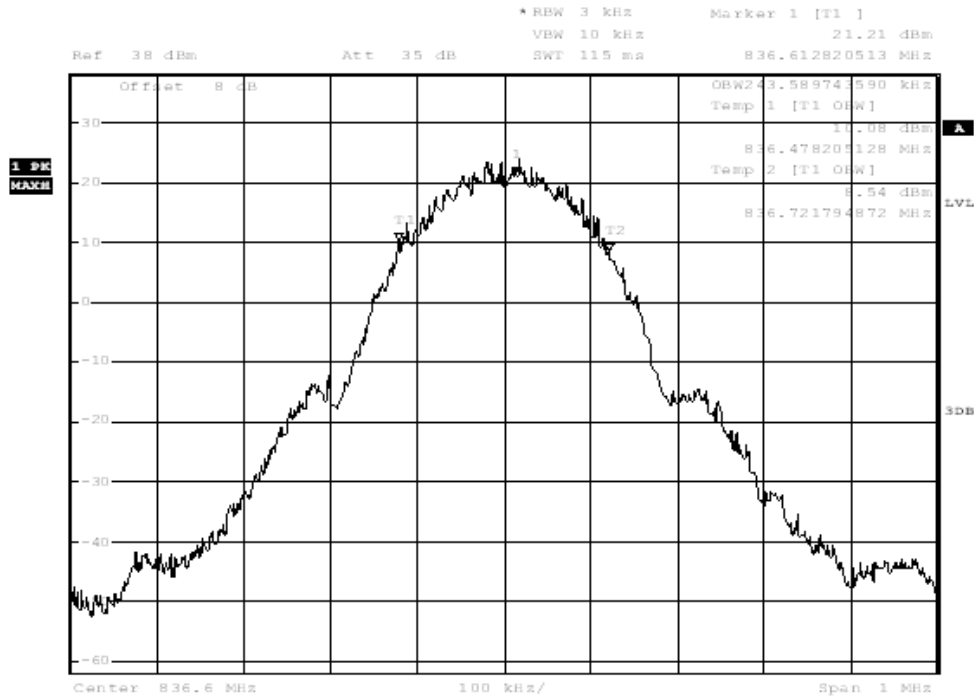

Date: 5.MAR.2012 21:54:53

### Channel 190

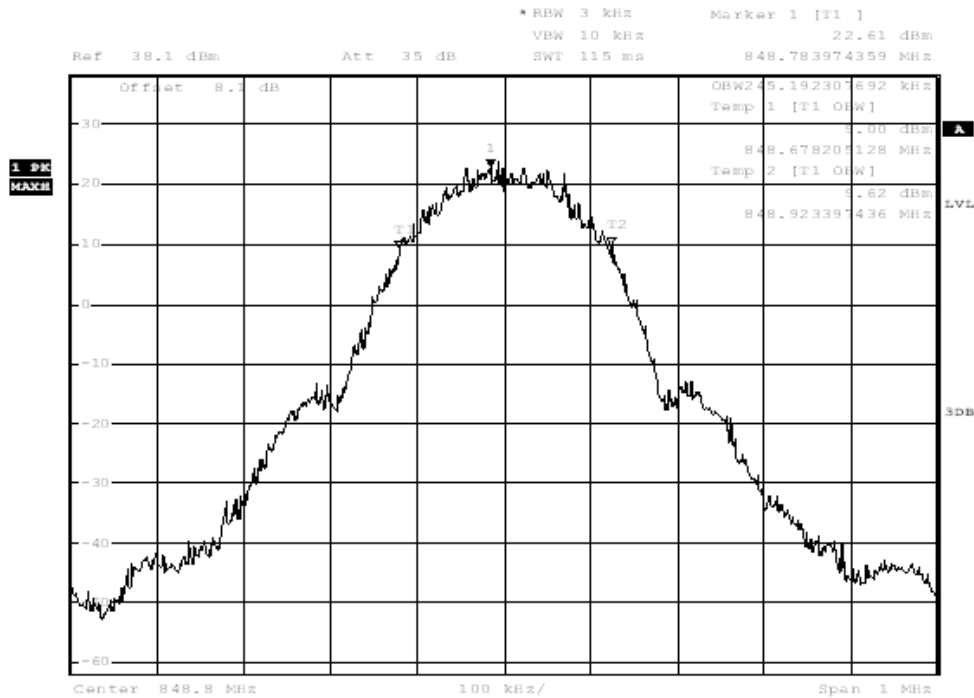

Date: 5.MAR.2012 21:55:29

### Channel 251

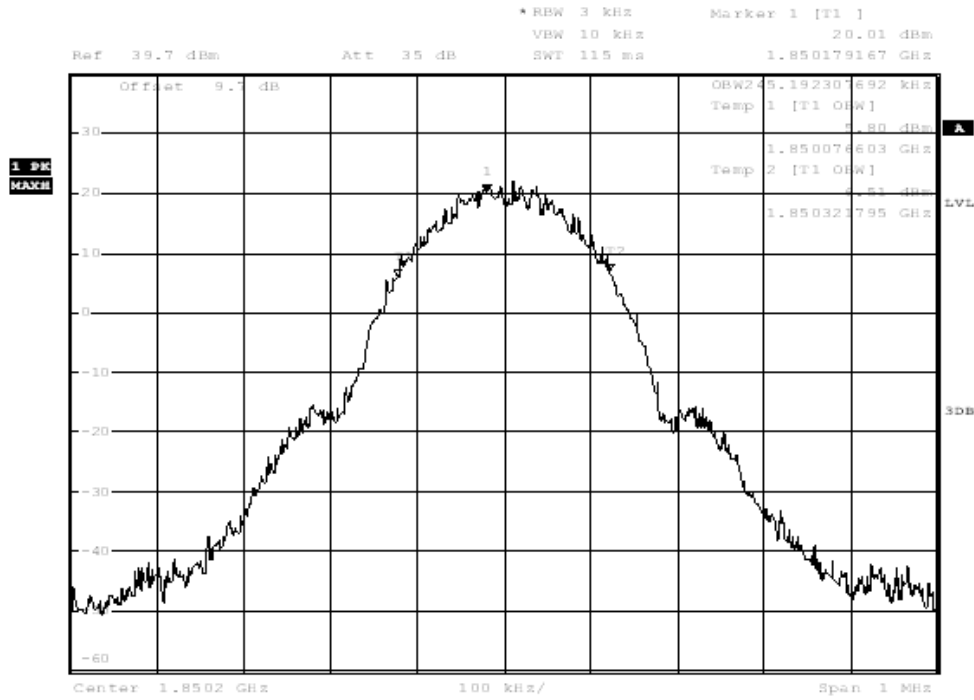

Date: 11. MAR. 2012 16:22:59

### Channel 512

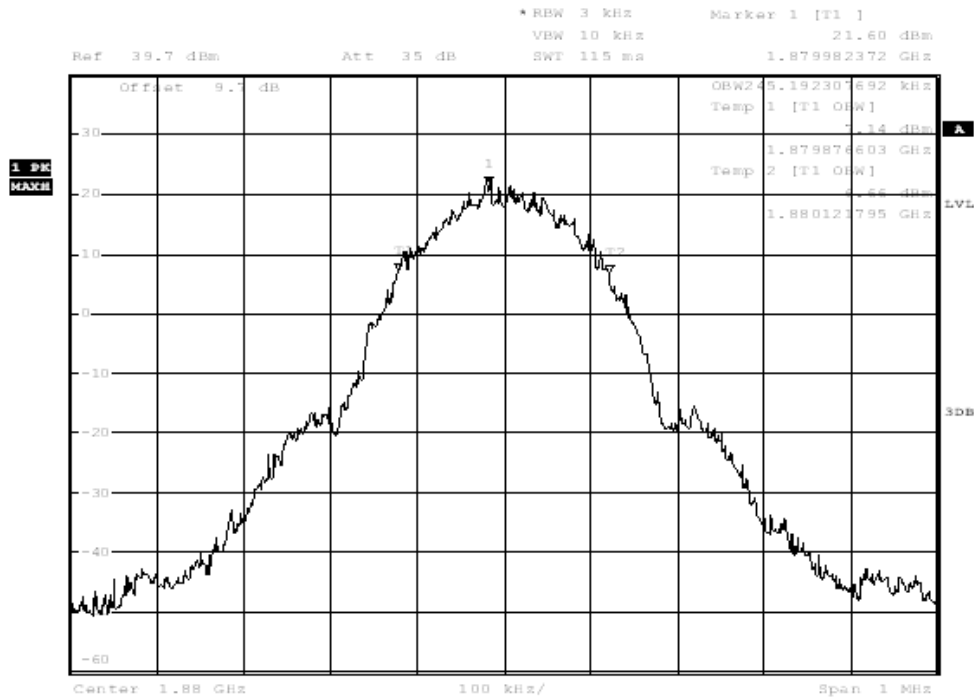

Date: 11. MAR. 2012 16:23:50

### Channel 661





**Results data of EGPRS mode:**

EUT channel	99% occupied bandwidth [kHz]
128	245.19
190	243.59
251	243.59
512	243.59
661	241.99
810	240.38

**Graphical results for EGPRS mode:**

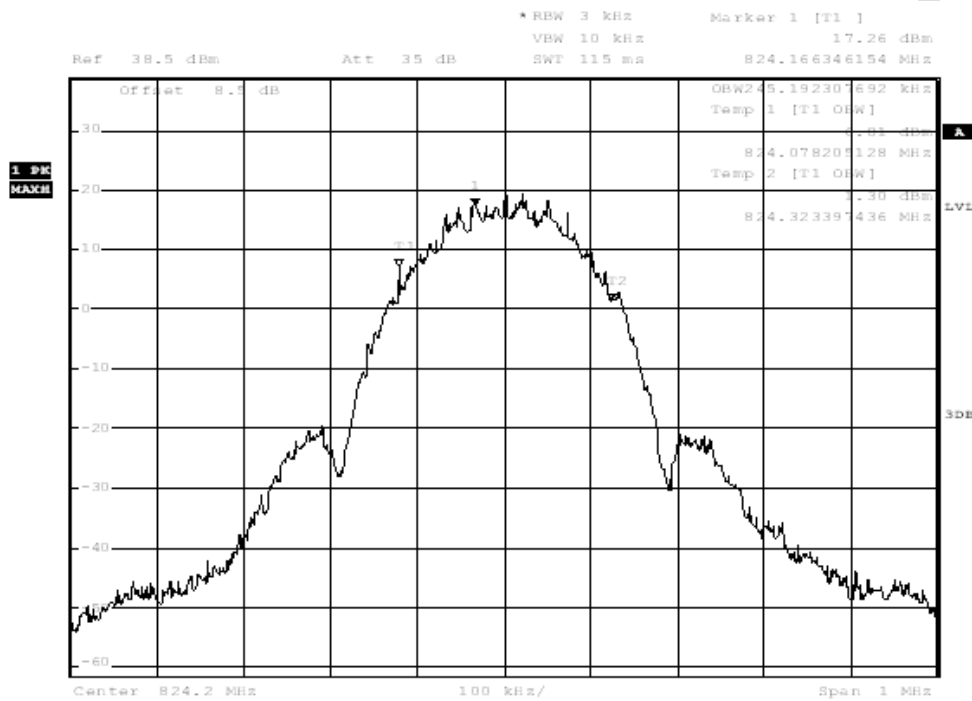

Date: 5.MAR.2012 22:15:36

**Channel 128**

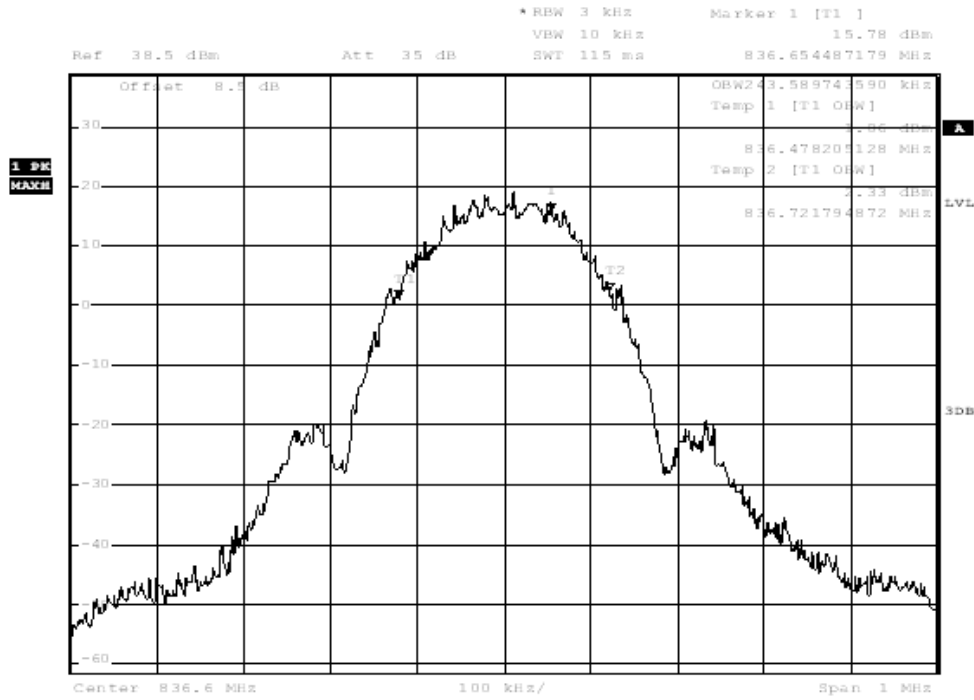

Date: 5.MAR.2012 22:16:12

### Channel 190

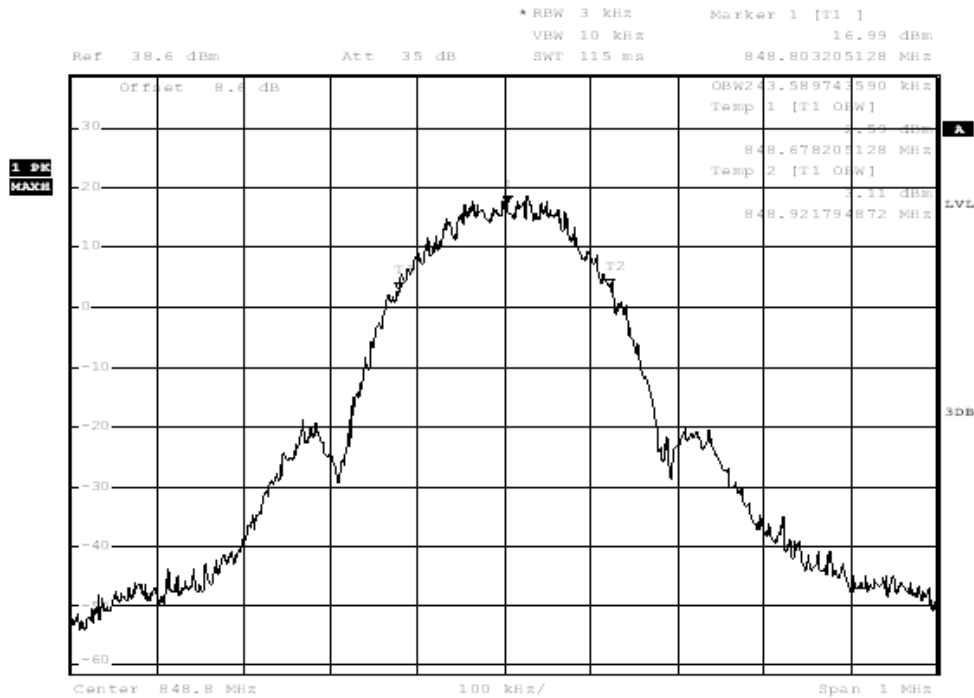

Date: 5.MAR.2012 23:16:48

### Channel 251

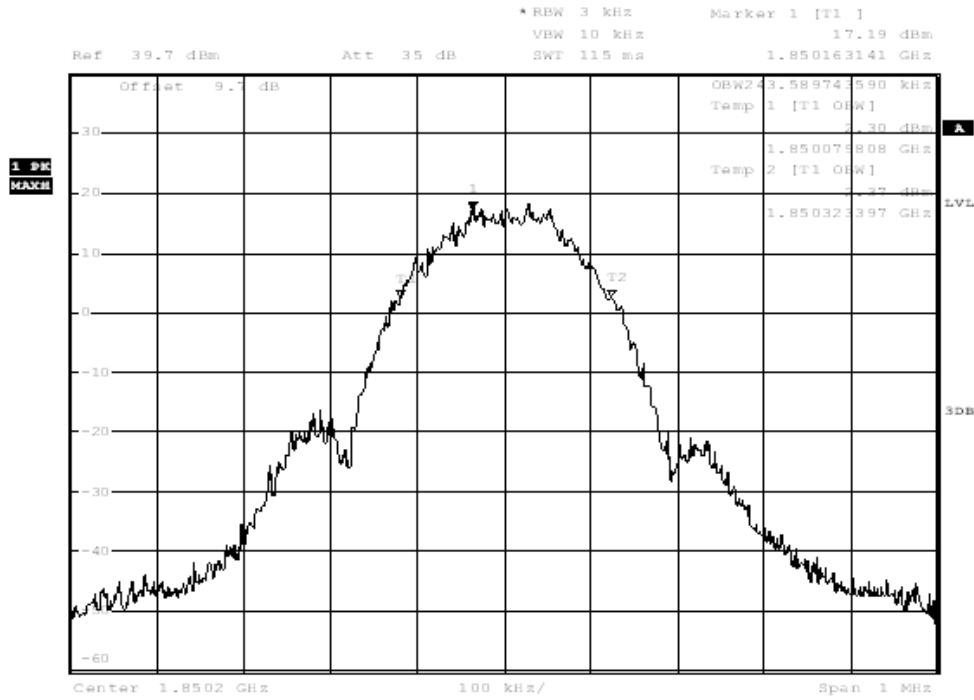

Date: 6.MAR.2012 16:28:40

### Channel 512

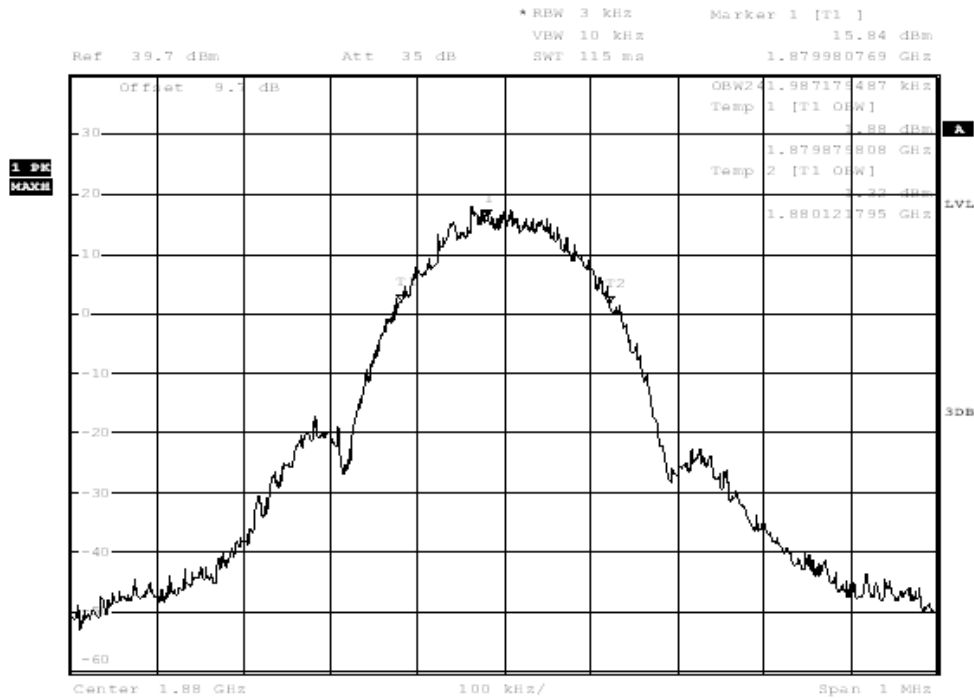

Date: 6.MAR.2012 16:29:16

### Channel 661

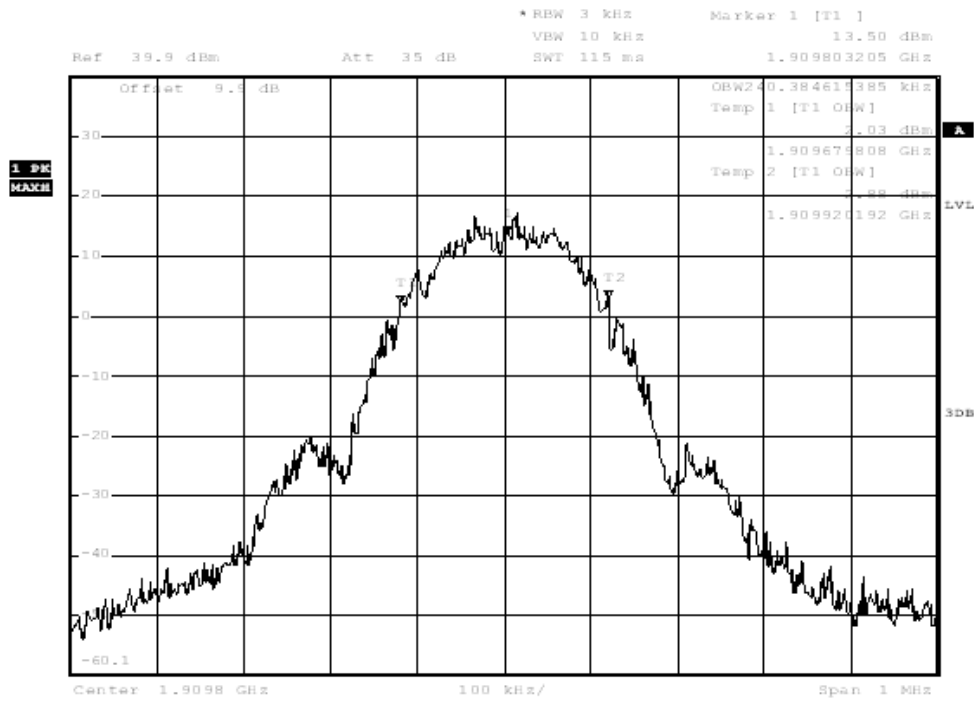

Date: 6.MAR.2012 16:29:52

Channel 810

CIT TEST

### 4.5 Emission bandwidth

<b>Specifications:</b>	22.917(b), 24.238(b)
<b>Operation Mode</b>	TX on, channel 128, 190, 251, 512, 661 and 810
<b>Test Results:</b>	Pass

#### Test Setup

The setup of emission bandwidth is similar to conducted emissions.

#### Test Method

The emission bandwidth measures -26dBc Spectrum analyzer plots from frequencies of PCS 1900 band and GSM 850 band.

**Note: --**

#### Results data of GSM mode:

EUT channel	-26dBc Emission bandwidth [kHz]
128	314.10
190	310.90
251	315.71
512	317.31
661	315.71
810	317.31

Graphical results for GSM mode:

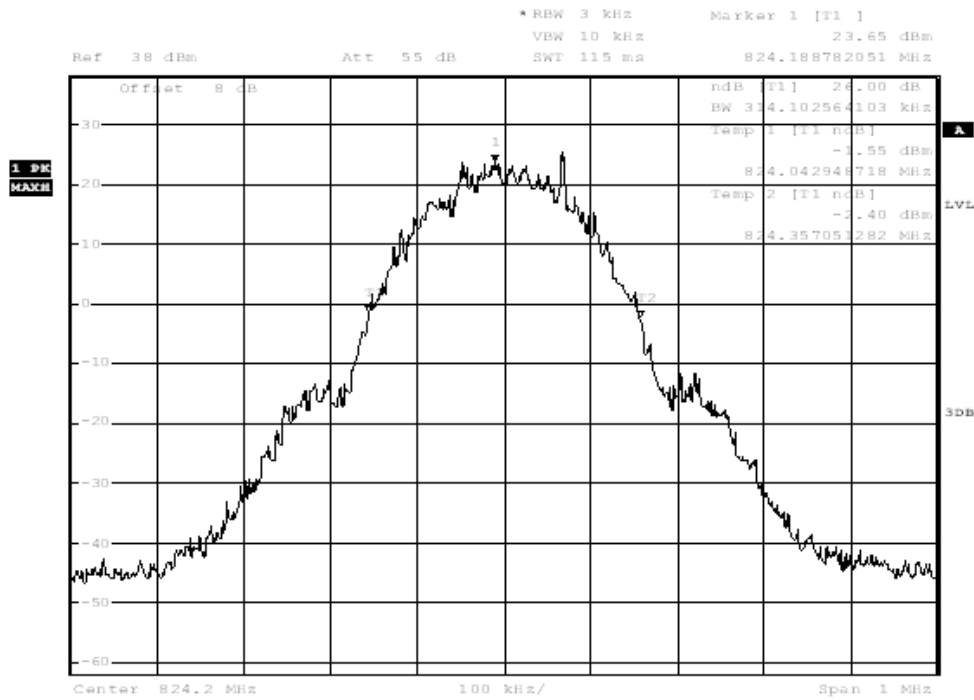

Date: 29.FEB.2012 23:47:03

Channel 128

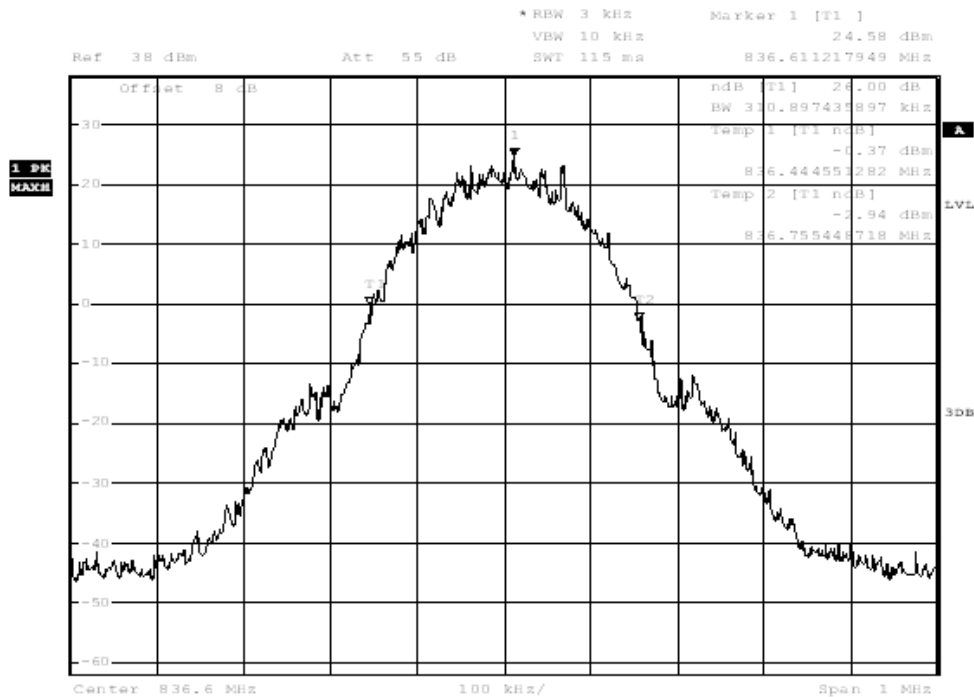

Date: 29.FEB.2012 23:47:39

Channel 190

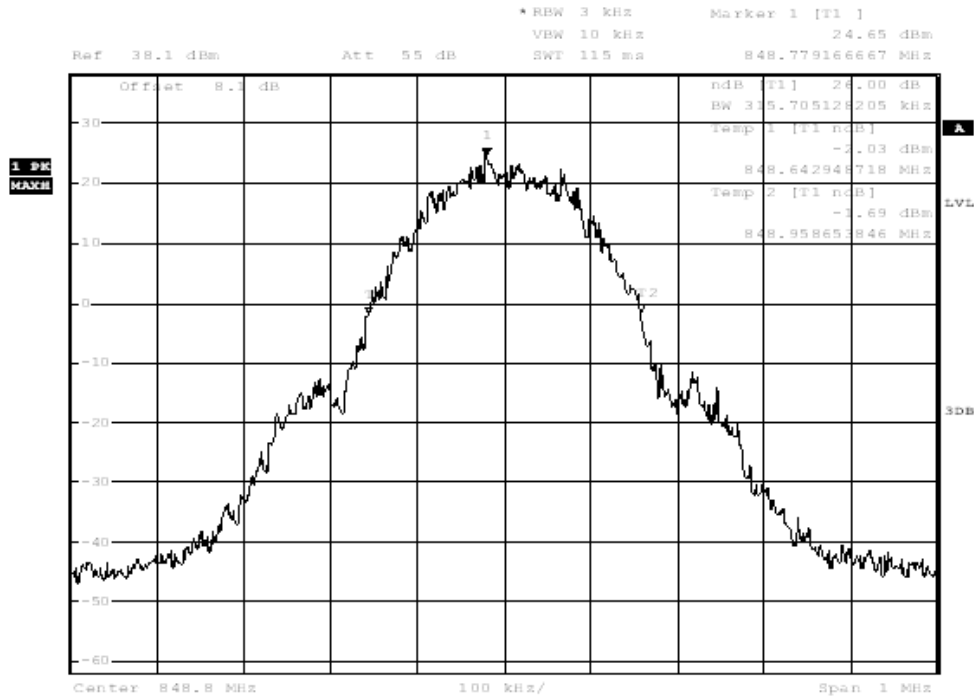

Date: 29.FEB.2012 23:48:15

### Channel 251

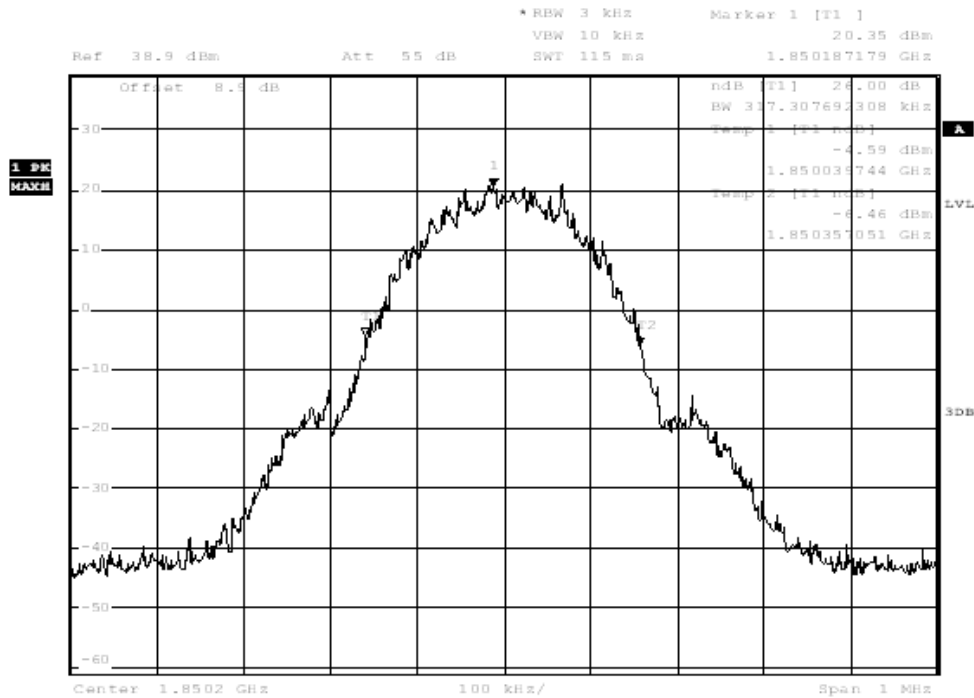

Date: 1.MAR.2012 00:19:42

### Channel 512



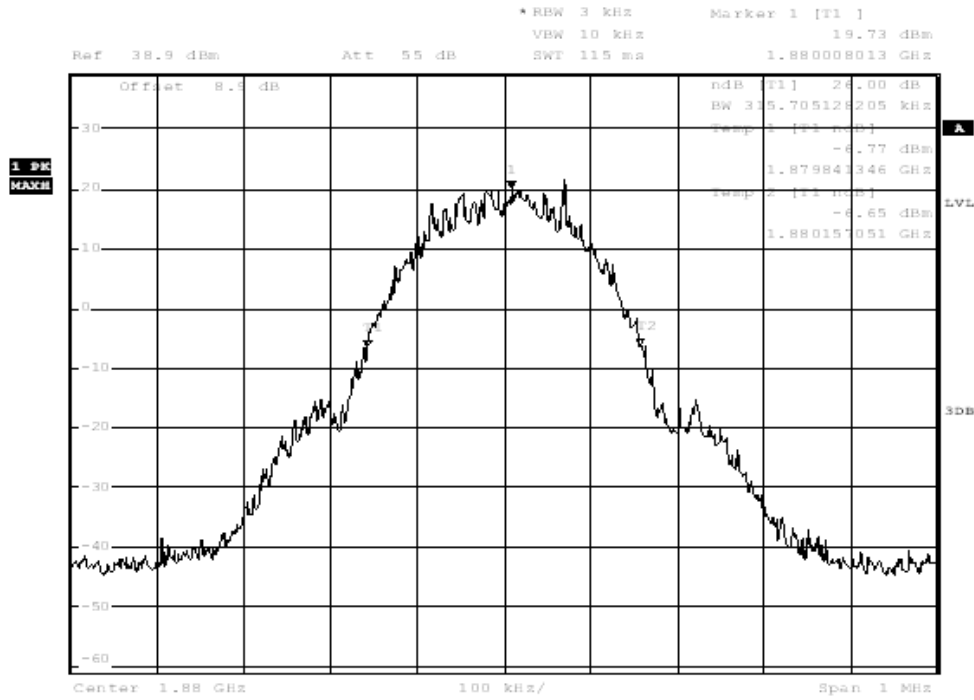

Date: 1.MAR.2012 00:20:18

### Channel 661

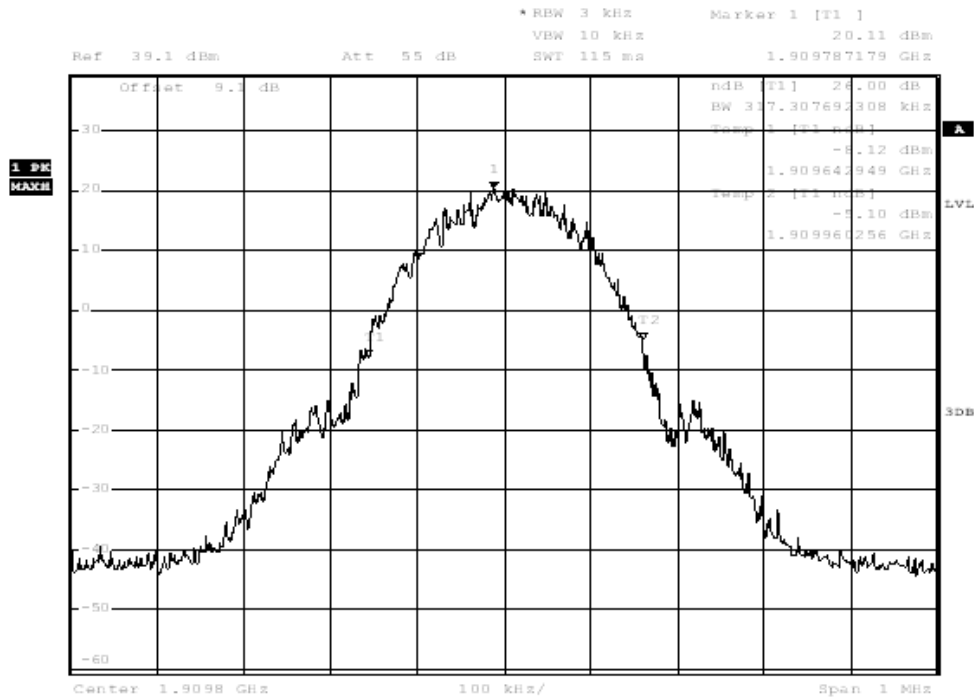

Date: 1.MAR.2012 00:20:55

### Channel 810

**Results data of GPRS mode:**

EUT channel	-26dBc Emission bandwidth [kHz]
128	315.71
190	315.71
251	315.71
512	318.91
661	317.31
810	317.31

**Graphical results for GPRS mode:**

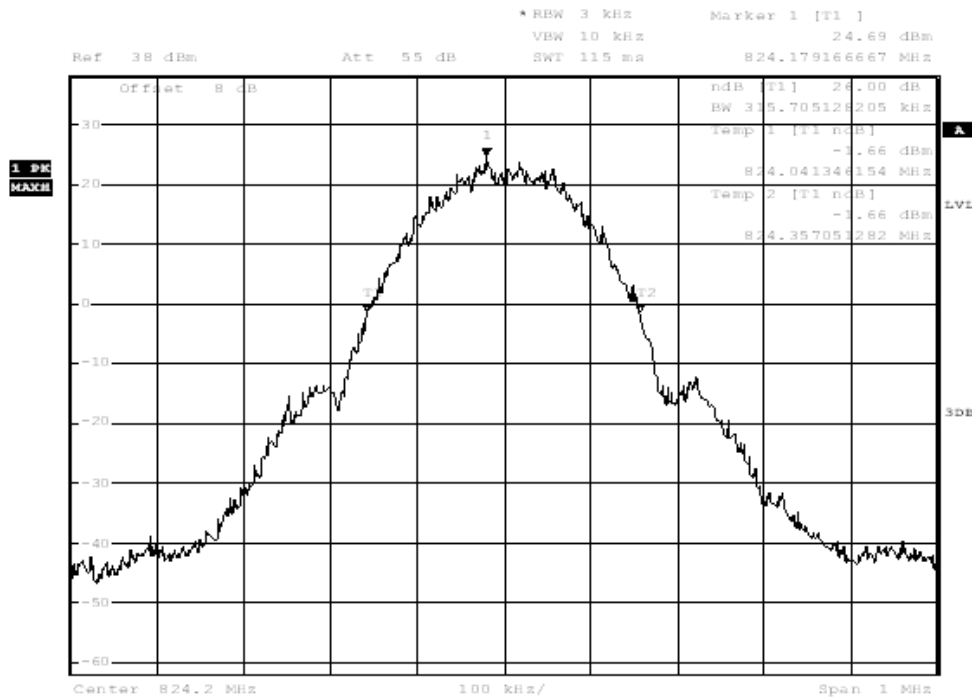

Date: 5.MAR.2012 21:54:06

**Channel 128**

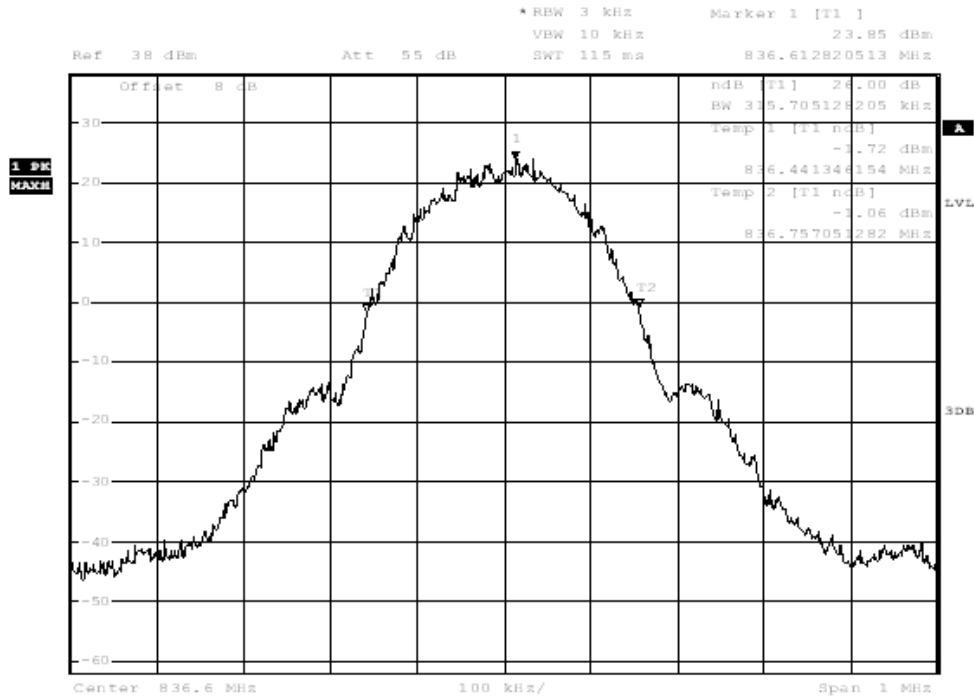

Date: 5.MAR.2012 21:54:42

### Channel 190

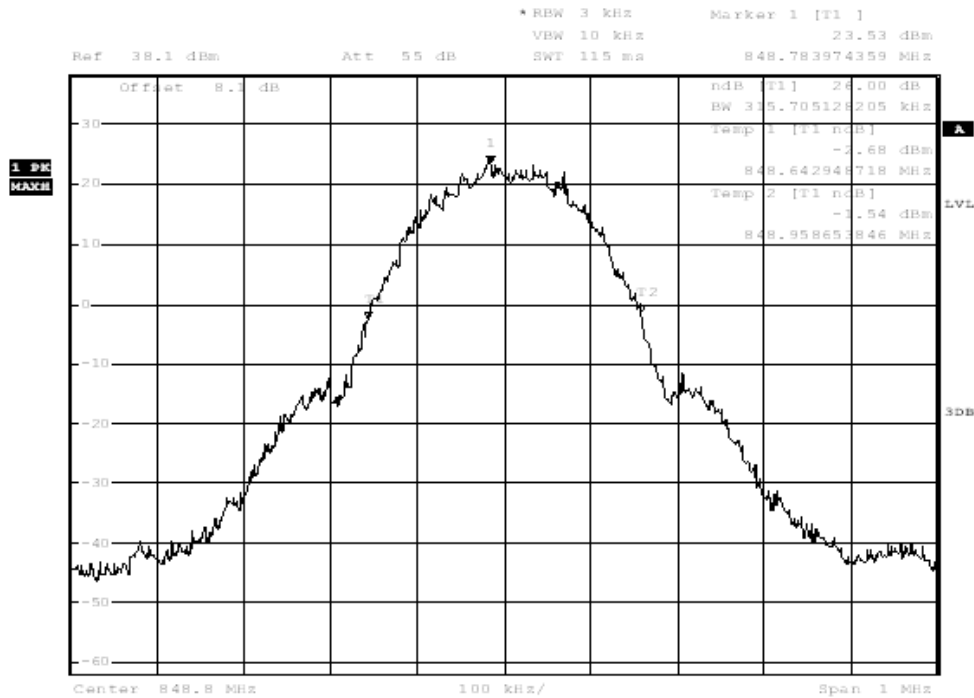

Date: 5.MAR.2012 21:55:17

### Channel 251

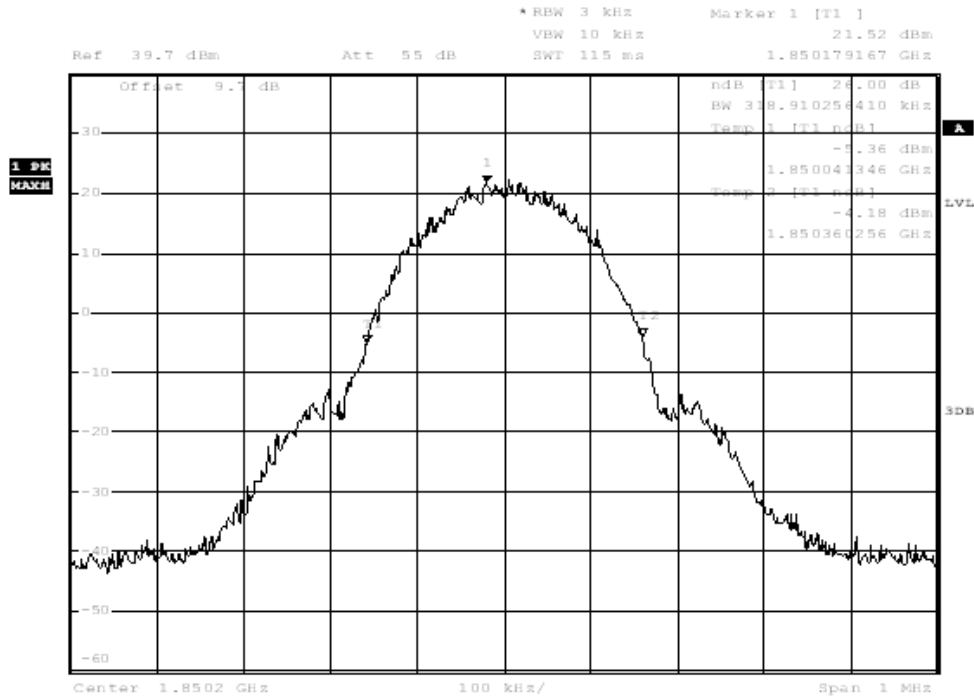

Date: 11.MAR.2012 16:22:37

### Channel 512

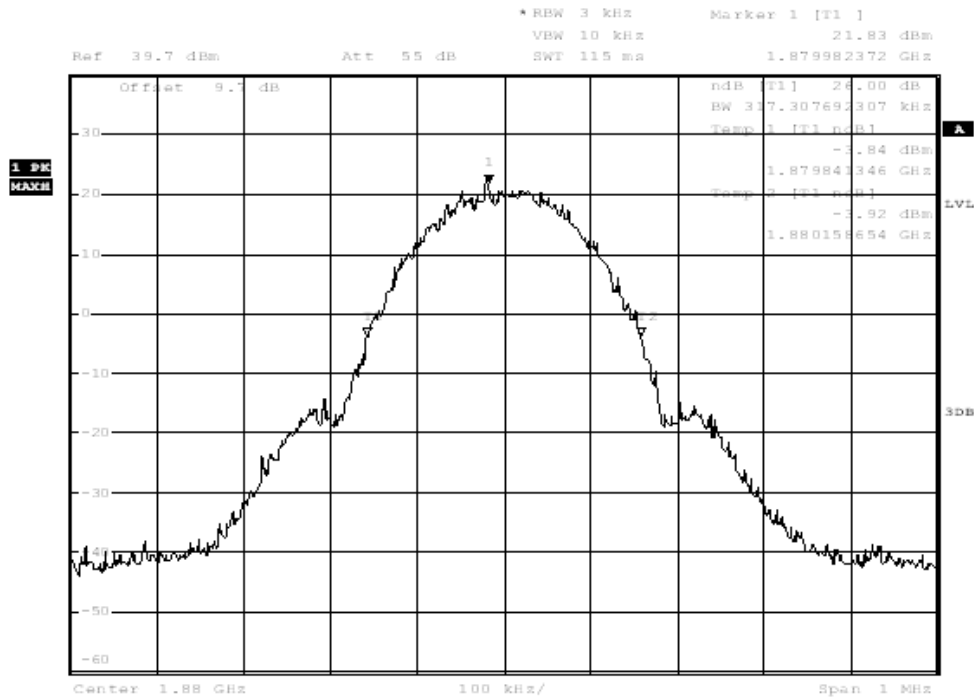

Date: 11.MAR.2012 16:23:28

### Channel 661

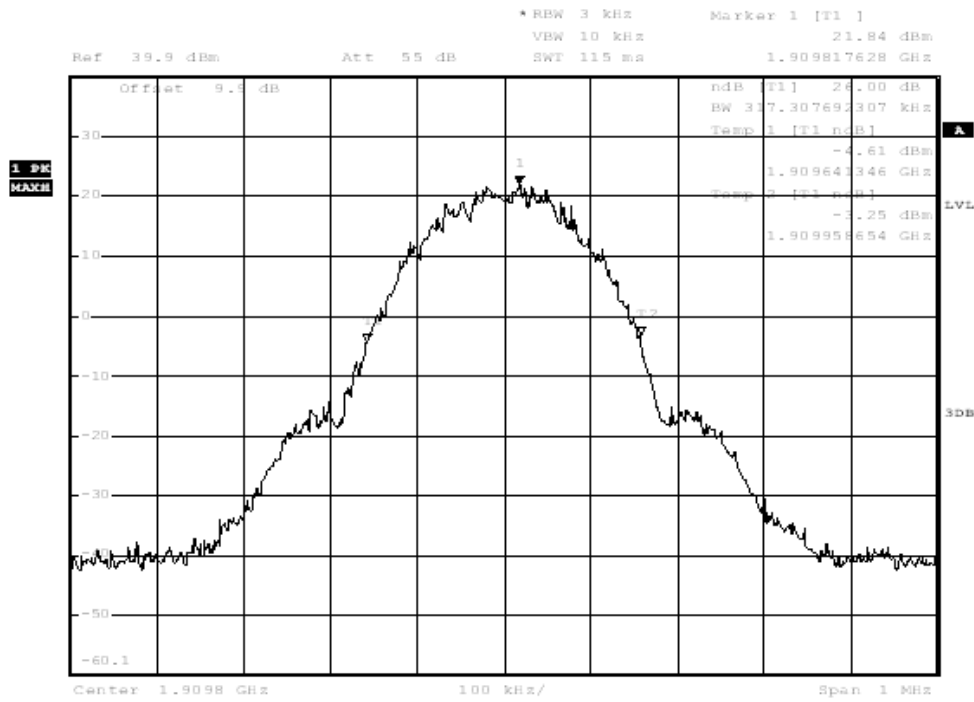

Date: 11. MAR. 2012 16:24:19

Channel 810

CITL TEST

**Results data of EGPRS mode:**

EUT channel	-26dBc Emission bandwidth [kHz]
128	314.10
190	307.69
251	306.09
512	314.10
661	307.69
810	309.29

**Graphical results for EGPRS mode:**

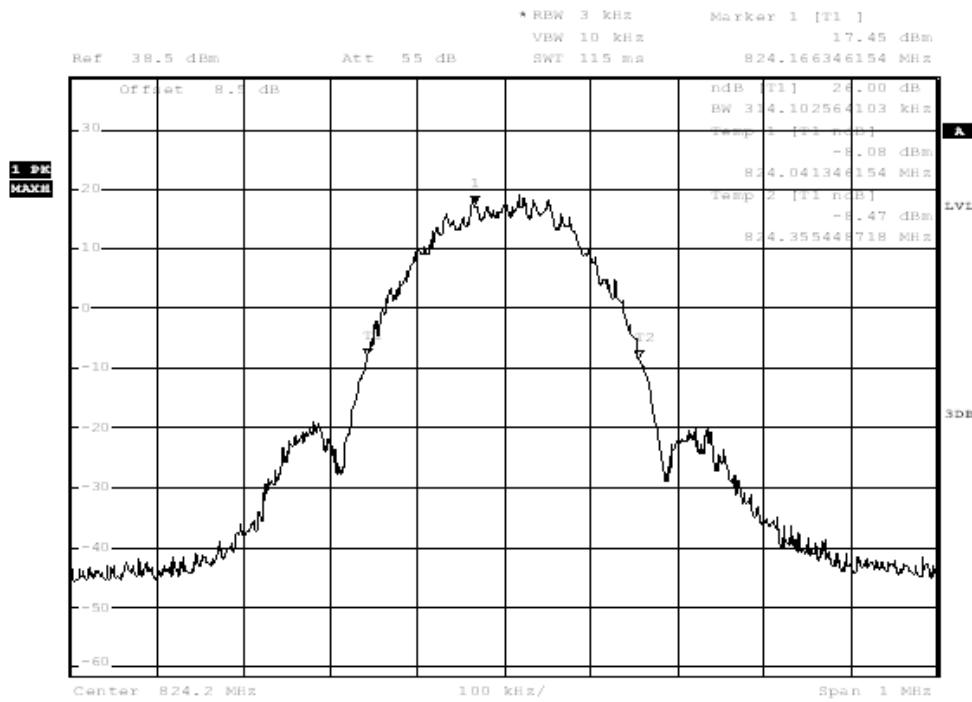

Date: 5.MAR.2012 23:15:24

**Channel 128**

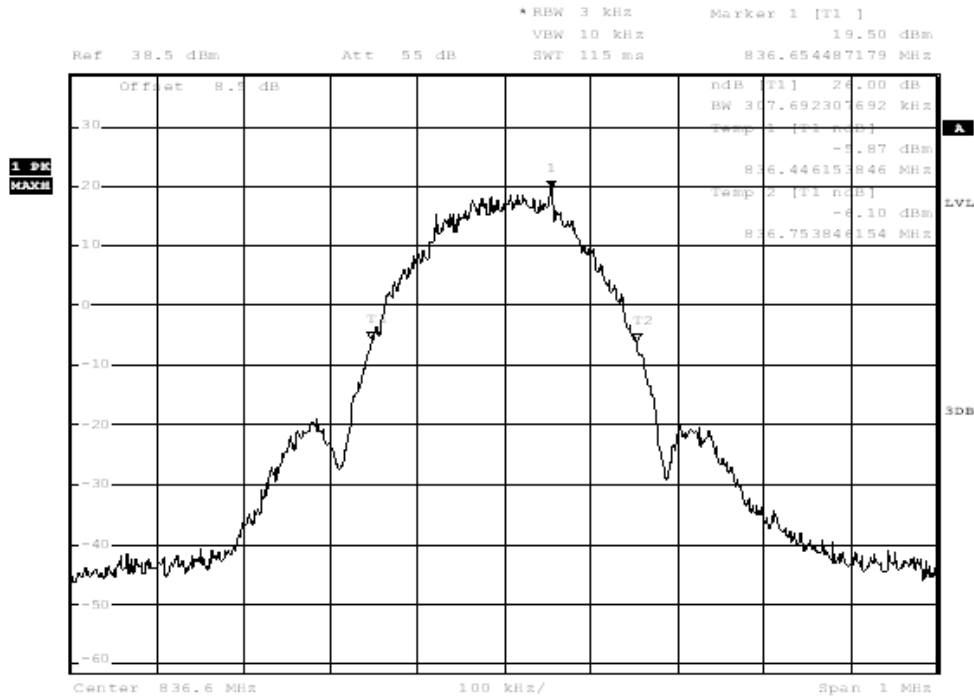

Date: 5.MAR.2012 22:16:00

### Channel 190

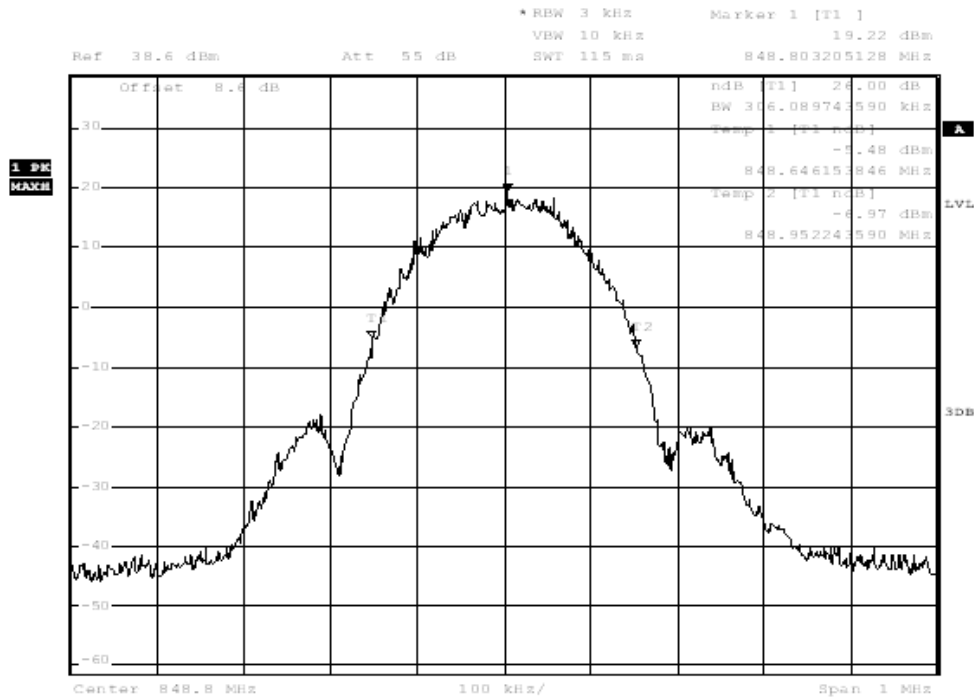

Date: 5.MAR.2012 23:16:36

### Channel 251

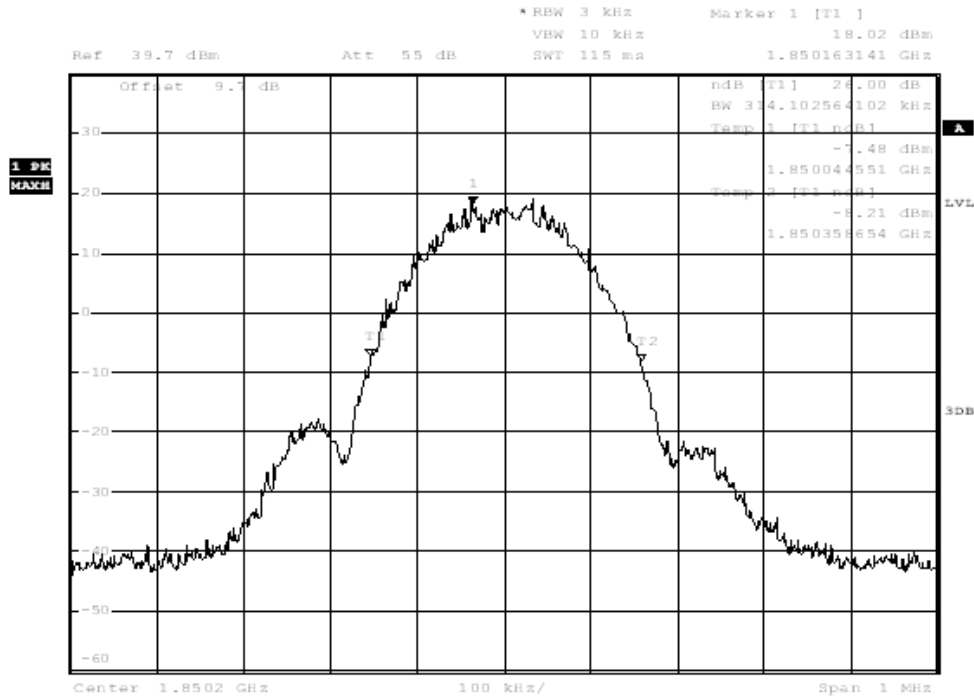

Date: 6.MAR.2012 16:28:28

### Channel 512

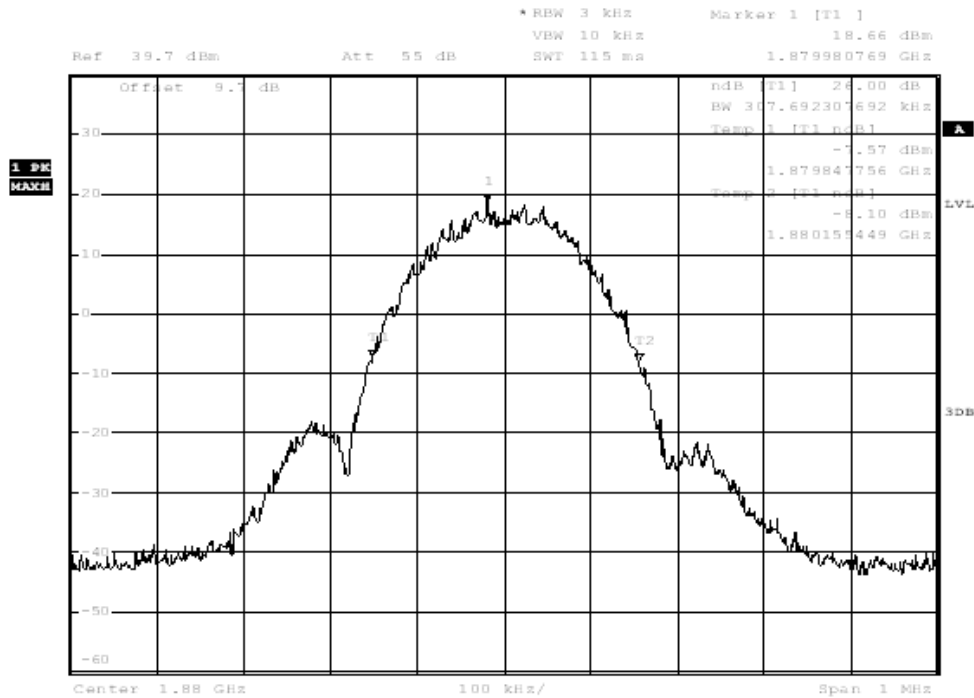

Date: 6.MAR.2012 16:29:04

### Channel 661



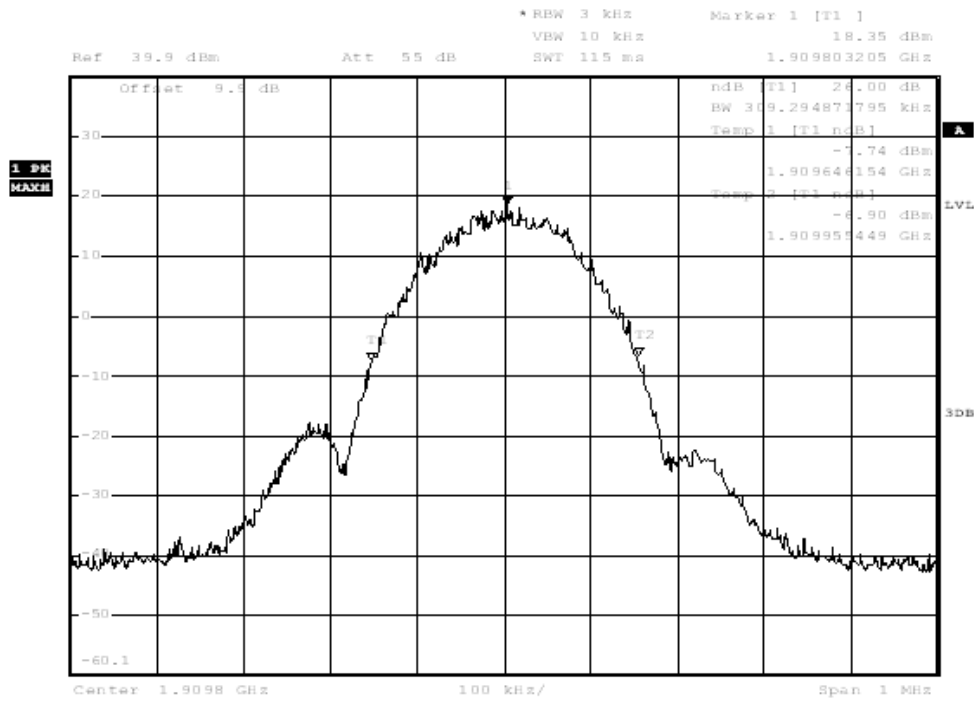

Date: 6.MAR.2012 16:29:40

Channel 810

### 4.6 Frequency Stability

<b>Specifications:</b>	2.1055,22.355, 24.235
<b>Test conditions:</b>	Ambient Temperature:-30°C-50°C Relative Humidity:30%-60% Air pressure: 86-106kPa
<b>Operation Mode</b>	TX on, channel 190 and 661
<b>Test Results:</b>	Pass
<b>Limit</b>	
Frequency deviation [ppm]	±2.5

#### 4.6.1 Frequency stability over temperature variation

##### Test Setup

The EUT was placed in a temperature chamber, demonstrated as figure T. The wireless communications test set (test simulator) was used to set the TX channel and power levels, modulate the TX signal with different bit patterns and measure the frequency of TX.

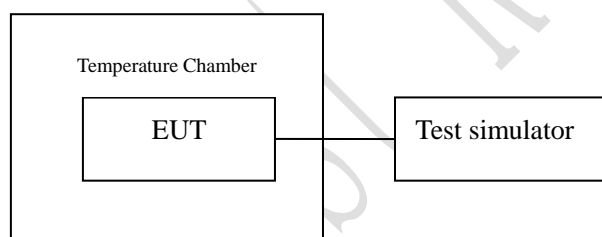

Figure T: setup for measurement of frequency stability over temperature variation

##### Test Method

1. The EUT was turned off and placed in the temperature chamber.
2. The temperature of the chamber was set to -30°C and allowed to stabilize.
3. The EUT temperature was allowed to stabilize for 45 minutes.
4. The EUT was turned on and set to transmit with CMU200.
5. The maximum transmit frequency deviation during one minute period was measured by Wireless Communications Test Set.
6. The steps 3-5 were repeated for -20°C, -10°C, 0°C, 10°C, 20°C, 30°C, 40°C and 50°C.

**Test results data for GSM mode:**

Channel 190:

Temperature[°C]	Deviation[Hz]	Remarks
-30	-25	Pass
-20	-14	Pass
-10	-19	Pass
0	-26	Pass
10	-16	Pass
20	-22	Pass
30	-7	Pass
40	8	Pass
50	-2	Pass

Channel 661:

Temperature[°C]	Deviation[Hz]	Remarks
-30	-45	Pass
-20	-48	Pass
-10	-50	Pass
0	-70	Pass
10	-60	Pass
20	-62	Pass
30	-50	Pass
40	-32	Pass
50	-31	Pass

**Test results data for GPRS mode:**

Channel 190:

Temperature[°C]	Deviation[Hz]	Remarks
-30	-28	Pass
-20	-21	Pass
-10	-38	Pass
0	-36	Pass
10	-34	Pass
20	-10	Pass
30	-30	Pass
40	12	Pass
50	5	Pass

Channel 661:

Temperature[°C]	Deviation[Hz]	Remarks
-30	-50	Pass
-20	-41	Pass
-10	-77	Pass
0	-43	Pass
10	-53	Pass
20	-76	Pass
30	-30	Pass
40	-55	Pass
50	-54	Pass

**Test results data for EGPRS mode:**

Channel 190:

Temperature[°C]	Deviation[Hz]	Remarks
-30	-46	Pass
-20	-44	Pass
-10	-20	Pass
0	-45	Pass
10	-46	Pass
20	-44	Pass
30	-38	Pass
40	-40	Pass
50	-33	Pass

Channel 661:

Temperature[°C]	Deviation[Hz]	Remarks
-30	-38	Pass
-20	-40	Pass
-10	-63	Pass
0	-60	Pass
10	-64	Pass
20	-61	Pass
30	-58	Pass
40	-48	Pass
50	-56	Pass

### 4.6.2 Frequency Stability over Voltage Variation

<b>Specifications:</b>	2.1055,22.355,24.235
<b>Test conditions:</b>	Ambient Temperature:15°C-35°C Relative Humidity:30%-60% Air pressure: 86-106kPa
<b>Operation Mode</b>	TX on, channel 190 and 661
<b>Test Results:</b>	Pass
<b>Limit</b>	
Frequency deviation [ppm]	±2.5

#### Test Setup

The EUT was placed in a shielding chamber and powered by the dummy battery which is connected to a DC power source, demonstrated as figure V. The wireless communications test set was used to set the TX channel and power level, modulate the TX signal with different bit patterns and measure the frequency of TX.

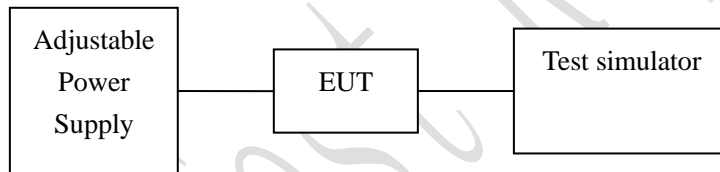

Figure V: test setup for measurement of frequency stability over voltage variation

#### Test Results data for GSM mode:

Channel 190:

Level	Voltage[V]	Deviation[Hz]	Remarks
Maximum	4.2	-19	Pass
Nominal	3.7	-8	Pass
Minimum	3.6	-22	Pass

Channel 661:

Level	Voltage[V]	Deviation[Hz]	Remarks
Maximum	4.2	-52	Pass
Nominal	3.7	-72	Pass
Minimum	3.6	-55	Pass

**Test Results data for GPRS mode:**

Channel 190:

Level	Voltage[V]	Deviation[Hz]	Remarks
Maximum	4.2	-18	Pass
Nominal	3.7	-22	Pass
Minimum	3.6	-15	Pass

Channel 661:

Level	Voltage[V]	Deviation[Hz]	Remarks
Maximum	4.2	-50	Pass
Nominal	3.7	-51	Pass
Minimum	3.6	-52	Pass

**Test Results data for EGPRS mode:**

Channel 190:

Level	Voltage[V]	Deviation[Hz]	Remarks
Maximum	4.2	-40	Pass
Nominal	3.7	-44	Pass
Minimum	3.6	-38	Pass

Channel 661:

Level	Voltage[V]	Deviation[Hz]	Remarks
Maximum	4.2	-65	Pass
Nominal	3.7	-63	Pass
Minimum	3.6	-70	Pass

### 4.7 Conducted Spurious Emission

<b>Specifications:</b>	2.1051,22.917,24.238
<b>Test conditions:</b>	Ambient Temperature:15°C-35°C Relative Humidity:30%-60% Air pressure: 86-106kPa
<b>Operation Mode</b>	TX on, channel 128, 190, 251, 512, 661 and 810
<b>Test Results:</b>	Pass

<p><b>Limit Level Construction:</b> According to Part 24.238 (a), i.e., Out of band emissions. The power of any emission outside of the authorized operating frequency ranges must be attenuated below the transmitting power (P) by a factor of at least 43 + 10 log(P) dB, so the limit level is: <math>P(\text{dBm}) - (43 + 10 \log(P)) \text{ dB} = -13\text{dBm}</math></p>
---

Limits for Radiated spurious emissions(UE)	
Frequency range	Limit Level /Resolution Bandwidth
30 MHz to 20000 MHz	-13dBm/1MHz

**Test Setup:**

During the process of testing, the EUT was controlled via Wireless Communications Test Set to ensure max power transmission and proper modulation and measured by Rhode & Schwarz EMI test receiver (ESI26)

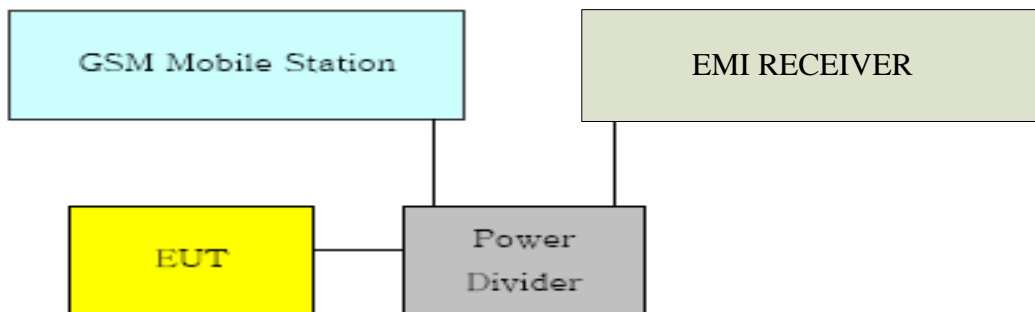

**Test Method**

The measurement was performed accordance with section 2.2.13 of ANSI/TIA-603-C-2004: *Land Mobile FM or PM Communications Equipment Measurement and Performance Standards*.

The following steps outline the procedure used to measure the conducted emissions from the EUT.

1. Determine frequency range for measurements: From CFR 2.1057 the spectrum should be investigated from the lowest radio frequency generated in the equipment up to at least the 10th harmonic of the carrier frequency. For the equipment under test, this equates to a frequency range of 30 MHz to 19.1 GHz,



data taken from 30 MHz to 20 GHz.

2. Determine EUT transmit frequencies: below outlines the band edge frequencies pertinent to conducted emissions testing.

**Note: --**

**Graphical results for GSM mode:**

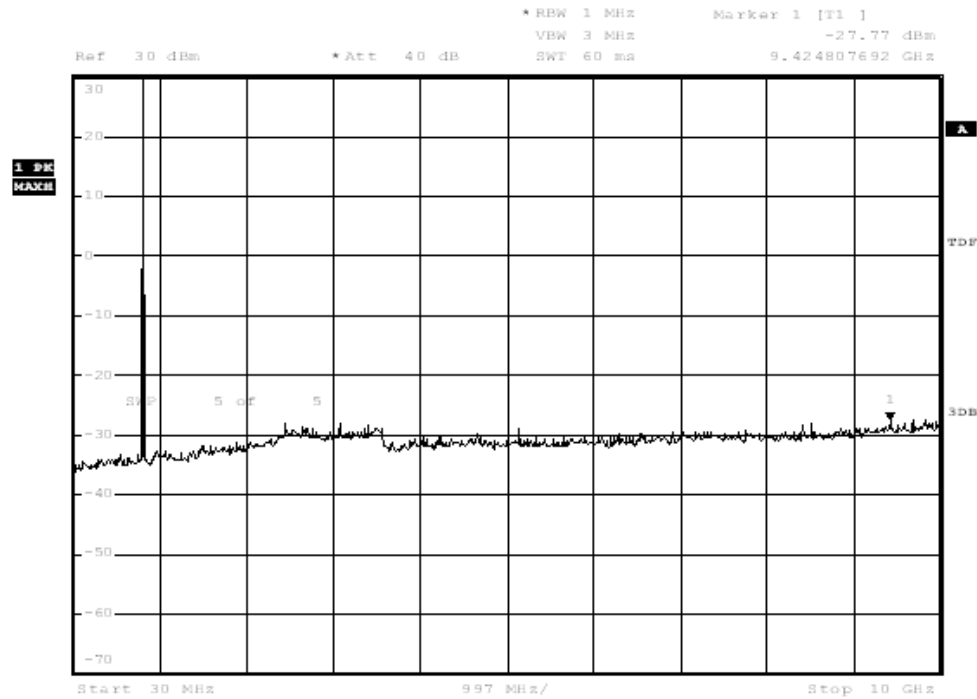

Date: 29.FEB.2012 23:48:48

**Channel 128**



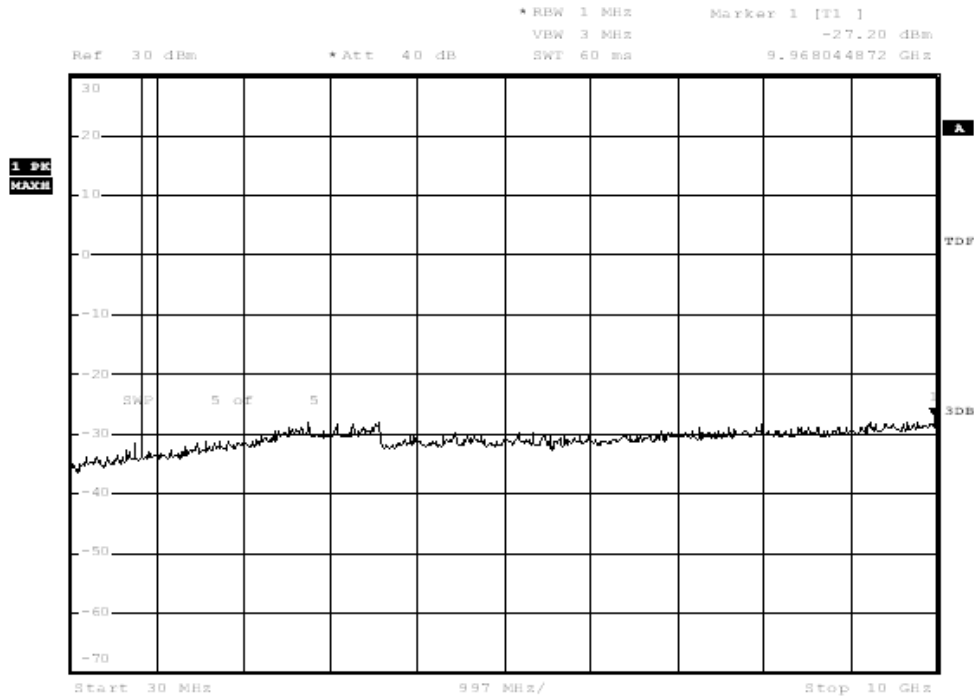

Date: 29.FEB.2012 23:49:08

### Channel 190

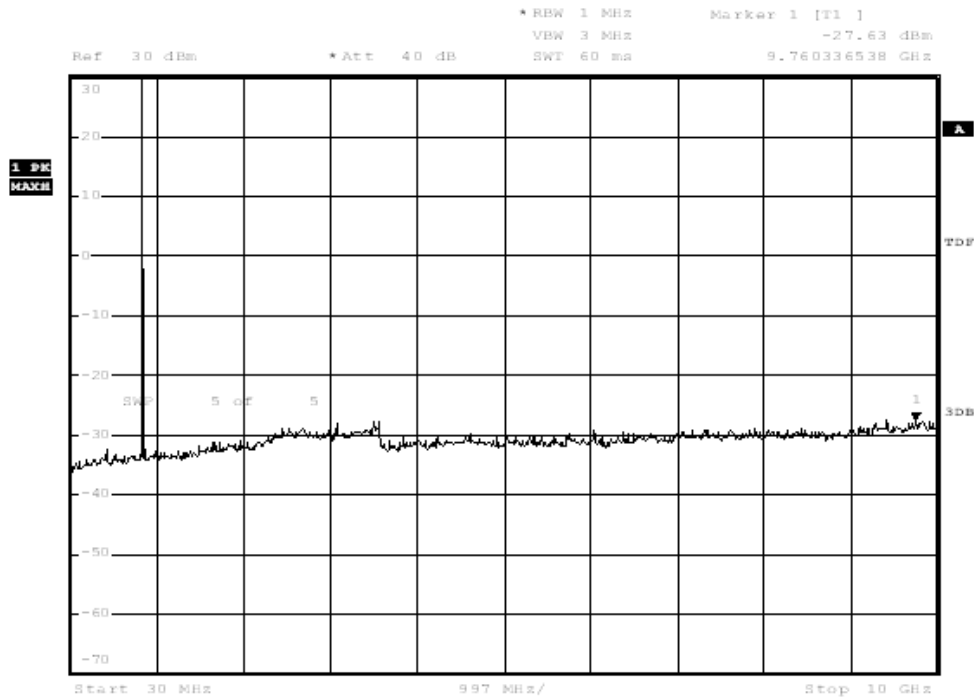

Date: 29.FEB.2012 23:49:29

### Channel 251

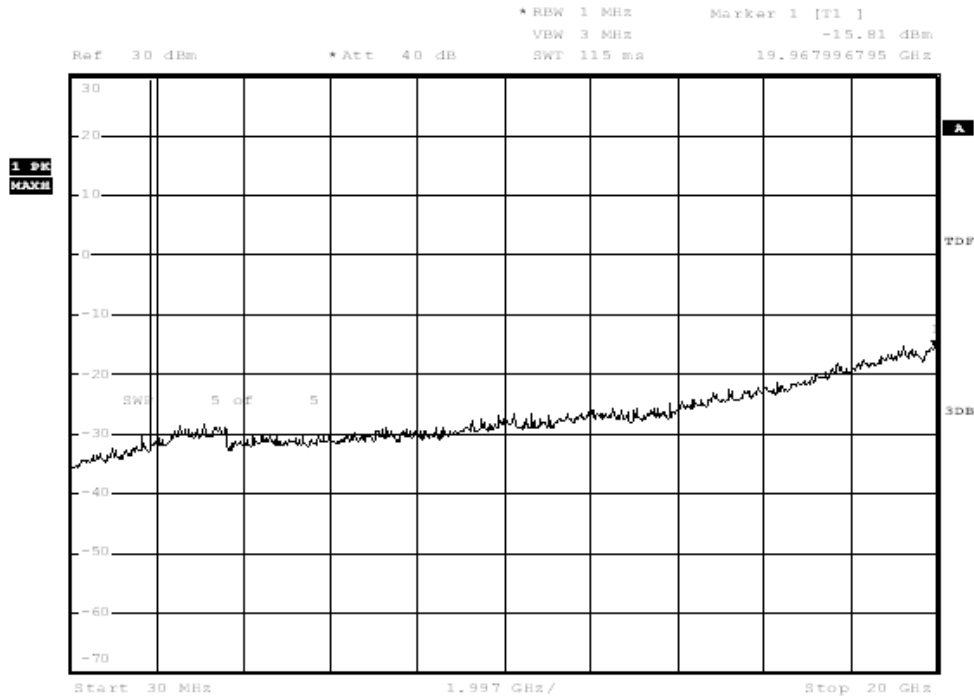

Date: 1.MAR.2012 00:16:28

### Channel 512

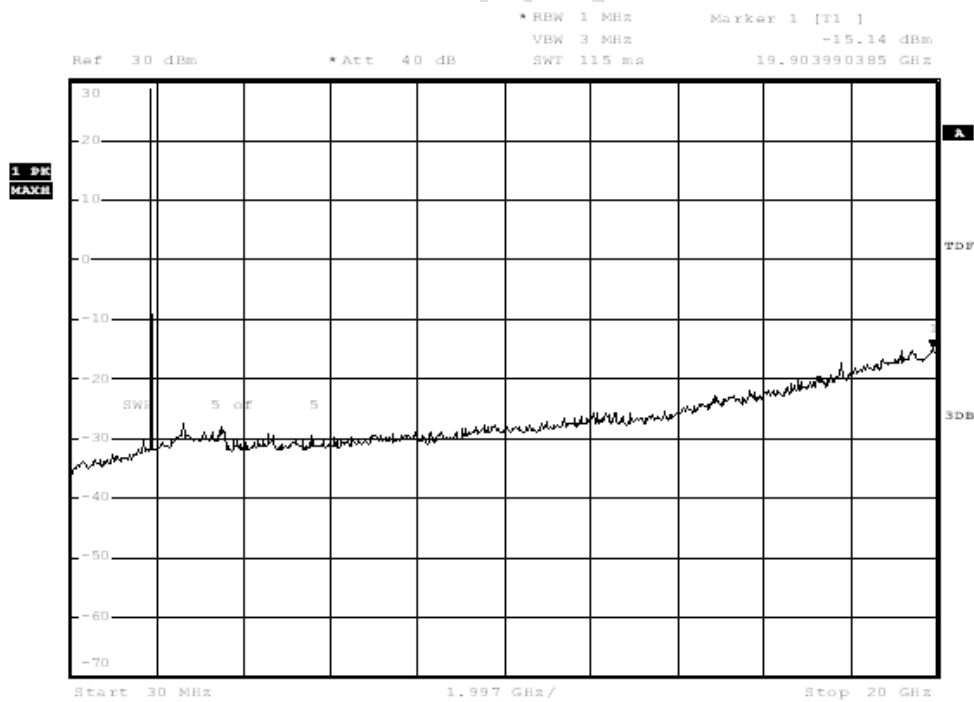

Date: 1.MAR.2012 00:16:49

### Channel 661

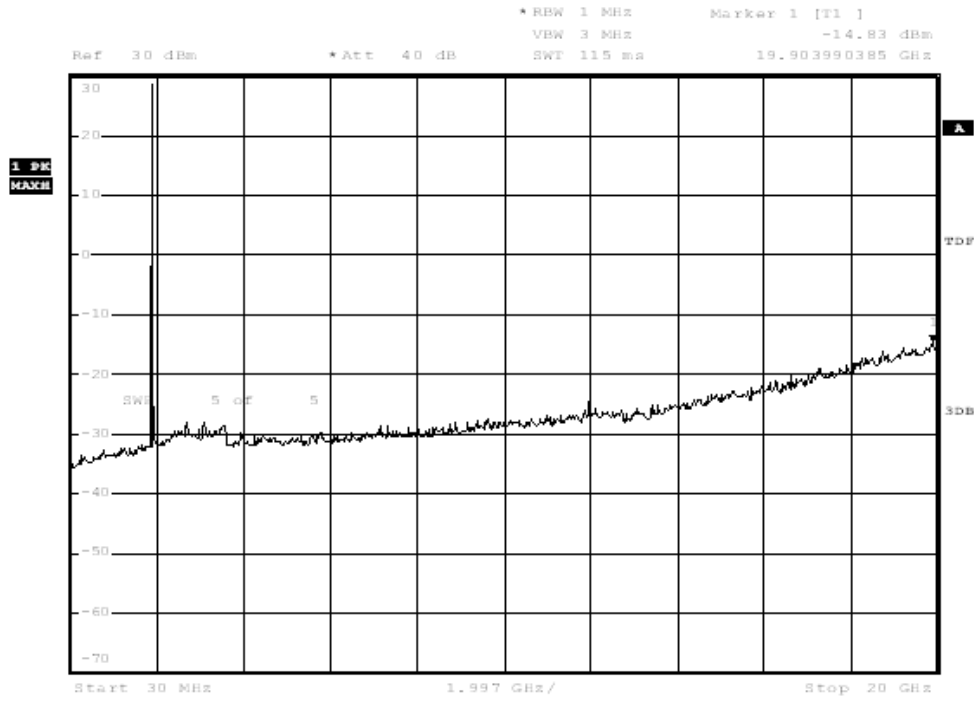

Date: 1.MAR.2012 00:17:09

Channel 810

CTTL TEST 1



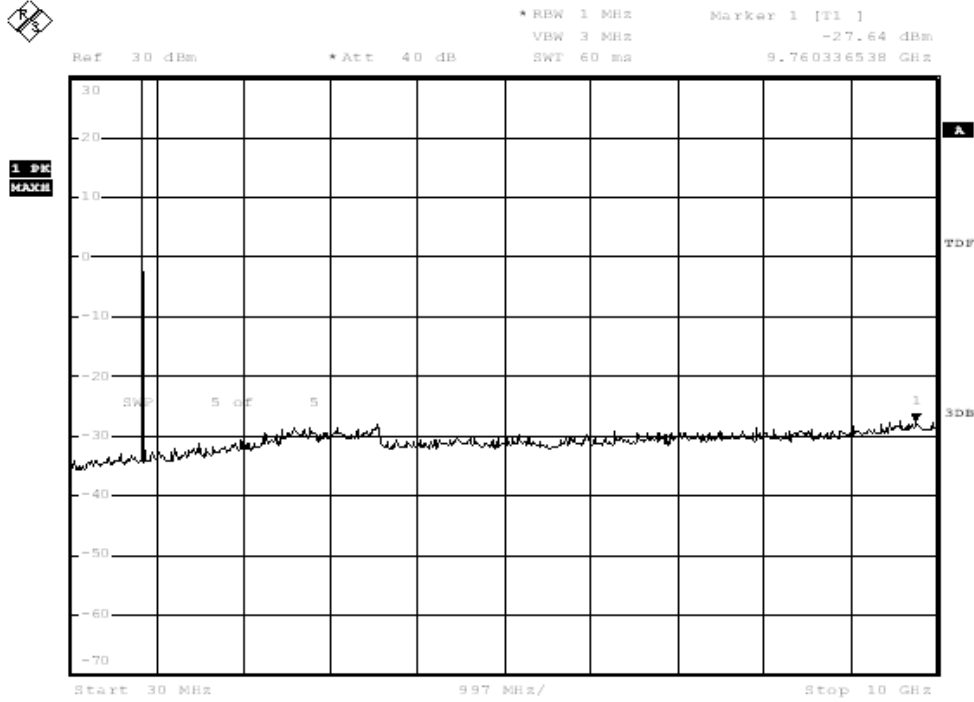

Date: 29.MAR.2012 01:25:49

### Channel 251

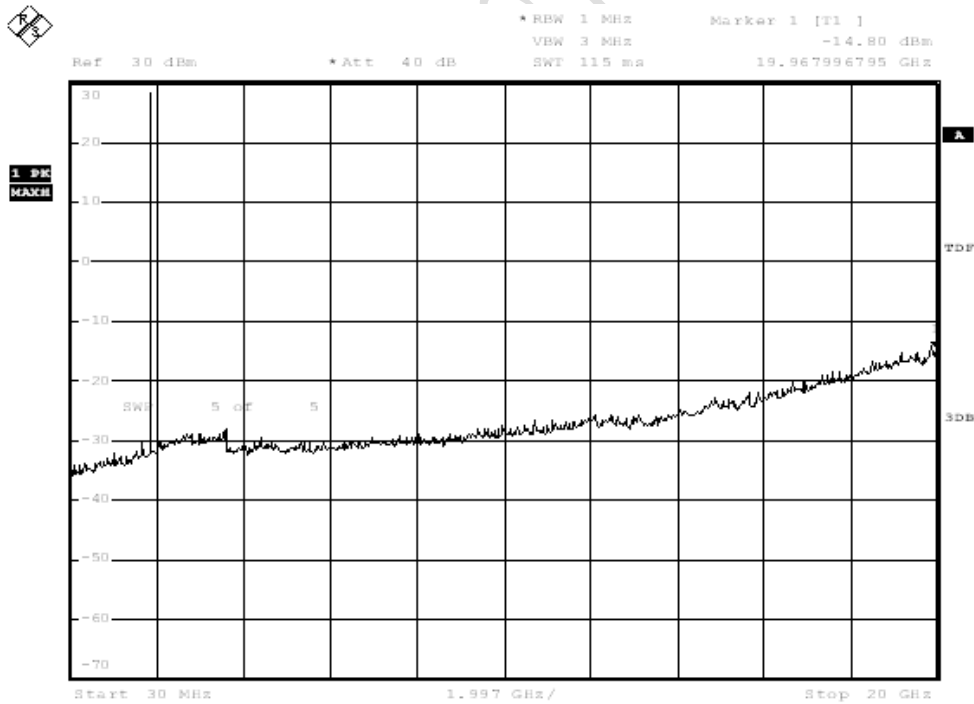

Date: 29.MAR.2012 17:34:20

### Channel 512

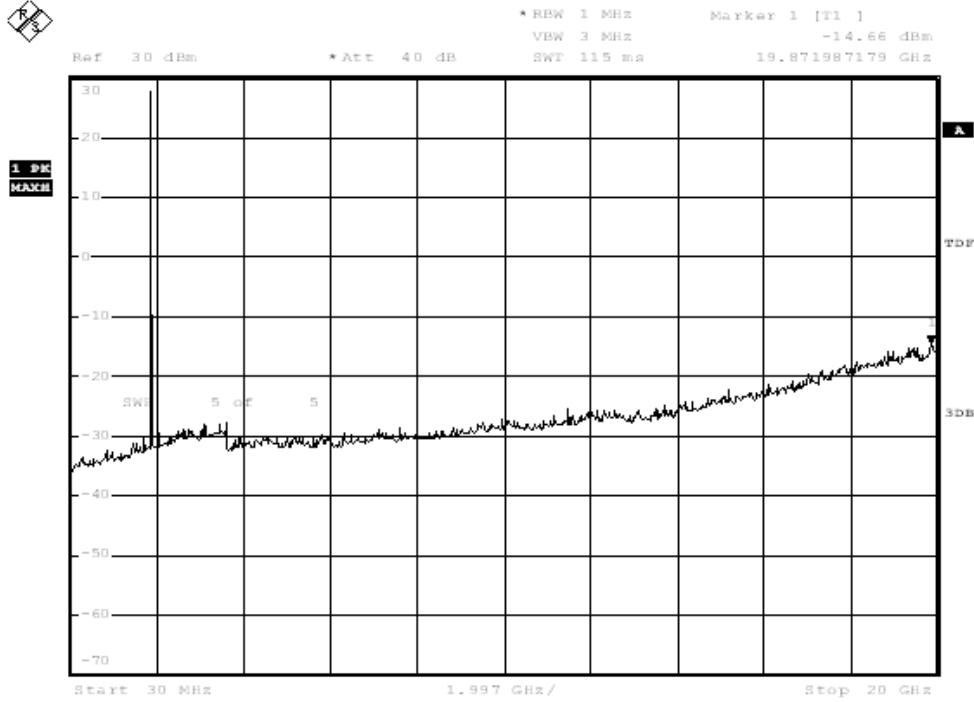

Date: 29.MAR.2012 01:32:06

### Channel 661

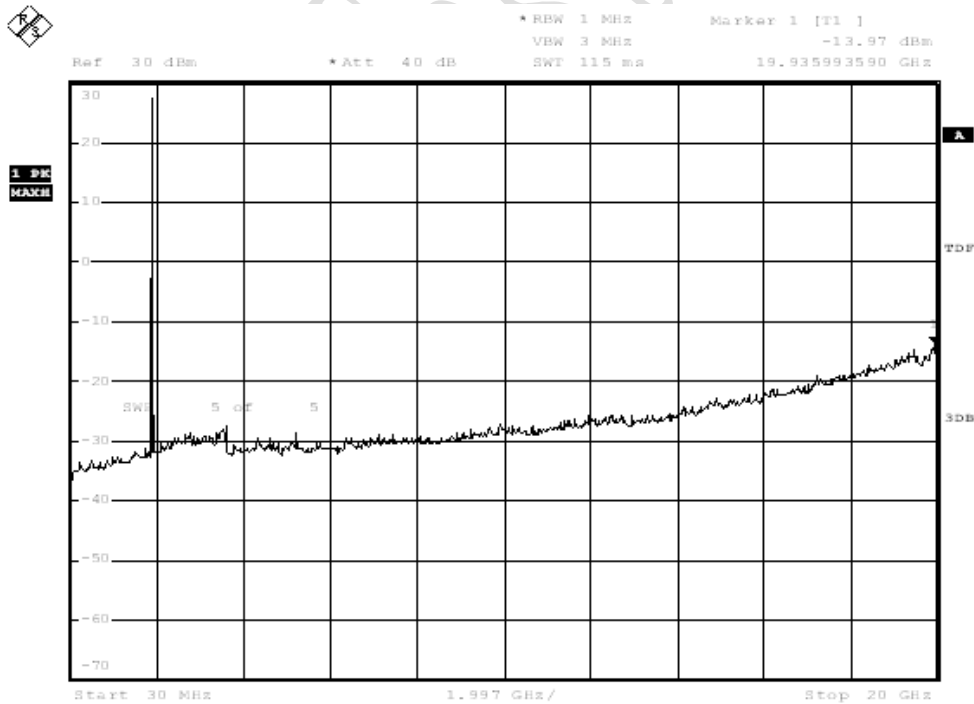

Date: 29.MAR.2012 01:32:25

### Channel 810

Graphical results for EGPRS mode:

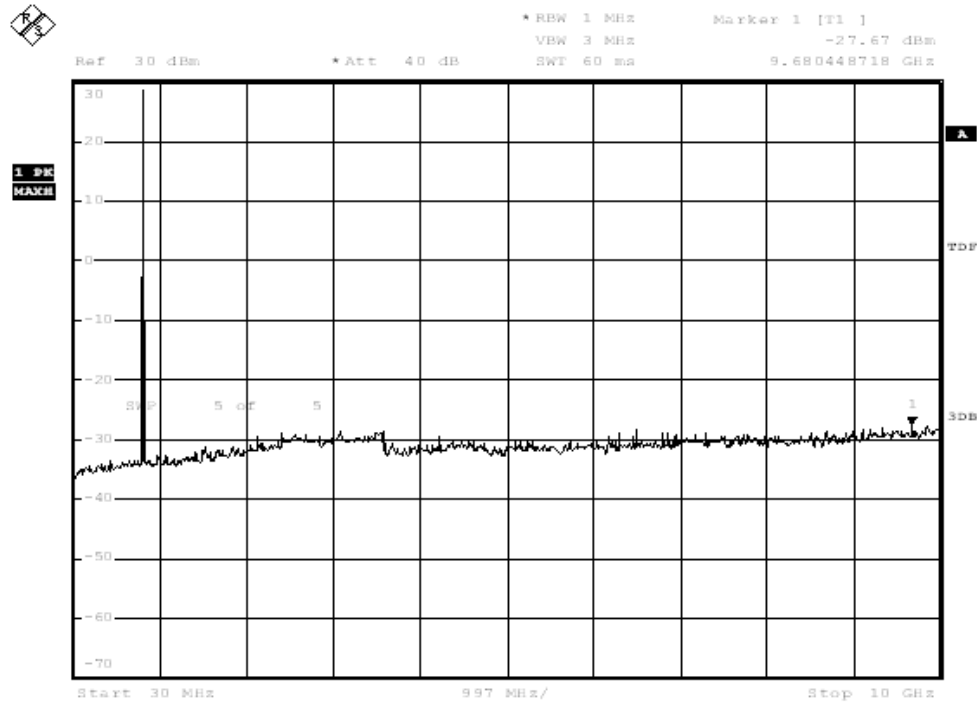

Date: 29.MAR.2012 17:42:29

Channel 128

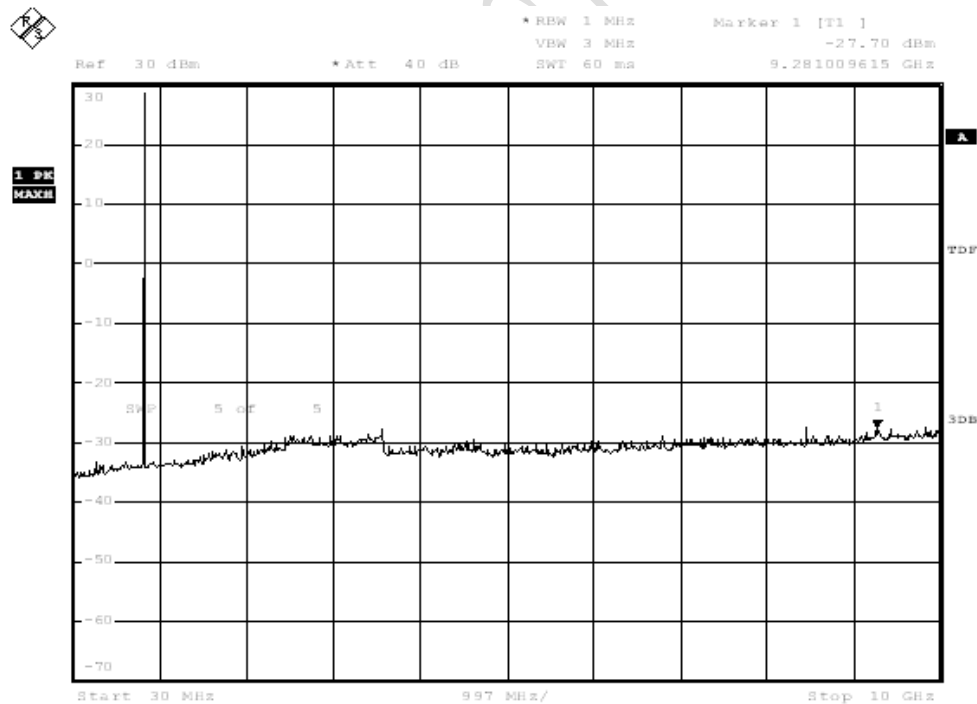

Date: 29.MAR.2012 17:42:49

Channel 190



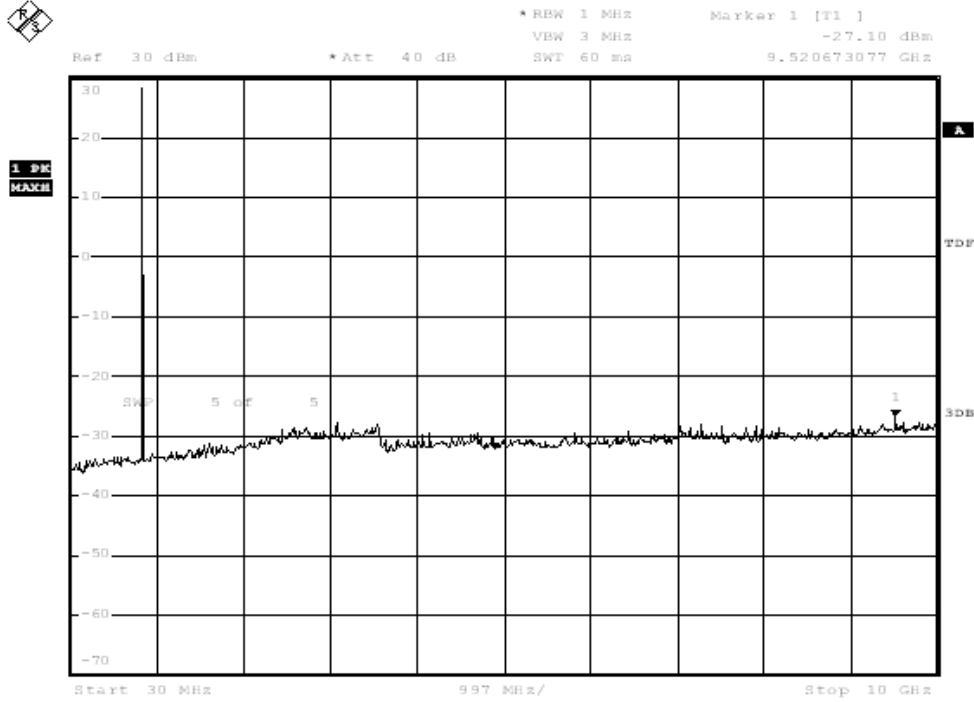

Date: 29.MAR.2012 17:43:09

### Channel 251

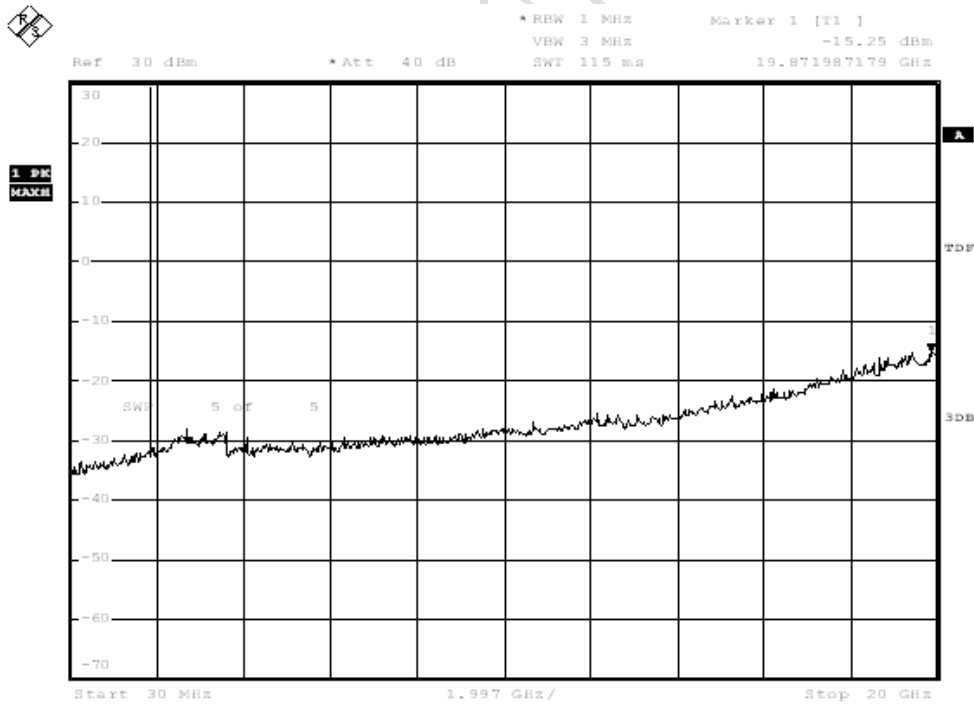

Date: 29.MAR.2012 01:40:36

### Channel 512



### 4.8 Band Edge Compliance

<b>Specifications:</b>	22.917(b), 24.238(b)
<b>Test conditions:</b>	Ambient Temperature:15°C-35°C Relative Humidity:30%-60% Air pressure: 86-106kPa
<b>Operation Mode</b>	TX on, channel 128, 251, 512 and 810
<b>Test Results:</b>	Pass

<p><b>Limit Level Construction:</b> According to Part 24.238 (a), i.e., Out of band emissions. The power of any emission outside of the authorized operating frequency ranges must be attenuated below the transmitting power (P) by a factor of at least 43 + 10 log(P) dB, so the limit level is: <math>P(\text{dBm}) - (43 + 10 \log(P)) \text{ dB} = -13\text{dBm}</math></p>
---

Limits for Radiated spurious emissions(UE)	
Frequency range	Limit Level /Resolution Bandwidth
30 MHz to 20000 MHz	-13dBm/1MHz

**Test Setup:**

During the process of testing, the EUT was controlled via the Wireless Communications Test Set to ensure max power transmission and proper modulation and measured by Rhode & Schwarz EMI test receiver (ESI26).

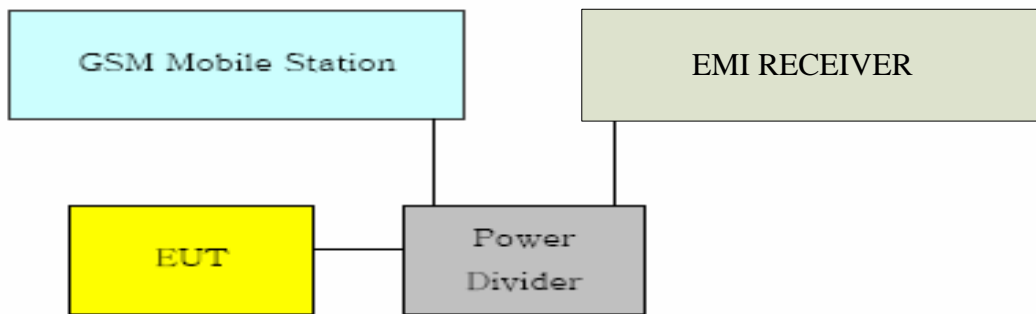

**Test Method**

- 1) The EUT was coupled to the EMI test receiver analyzer mode and the base station simulator through a power divider. The radio frequency load attached to the EUT antenna terminal was 50 Ohm. The attenuation of every cables of the test system is being taken into account by calibration to ensure measurement accuracy
- 2) The spectrum analyzer was set to Maxpeak Detector function and Maximum hold mode.
- 3) The resolution bandwidth of the spectrum analyzer was comparable to the

emission bandwidth.

**Note: --**

**Test Results:**

**GSM mode:**

Band-edge emission		
EUT Channel	Frequency [MHz]	Level [dBm]
128 Left band edge	824.000	-21.34
251 Right band edge	849.000	-19.61
512 Left band edge	1850.000	-23.74
810 Right band edge	1910.000	-23.22

**GPRS mode:**

Band-edge emission		
EUT Channel	Frequency [MHz]	Level [dBm]
128 Left band edge	824.000	-13.00
251 Right band edge	849.000	-13.08
512 Left band edge	1850.000	-16.96
810 Right band edge	1910.000	-15.63

**EGPRS mode:**

Band-edge emission		
EUT Channel	Frequency [MHz]	Level [dBm]
128 Left band edge	824.000	-26.18
251 Right band edge	849.000	-26.99
512 Left band edge	1850.000	-23.52
810 Right band edge	1910.000	-27.26

Graphical results:

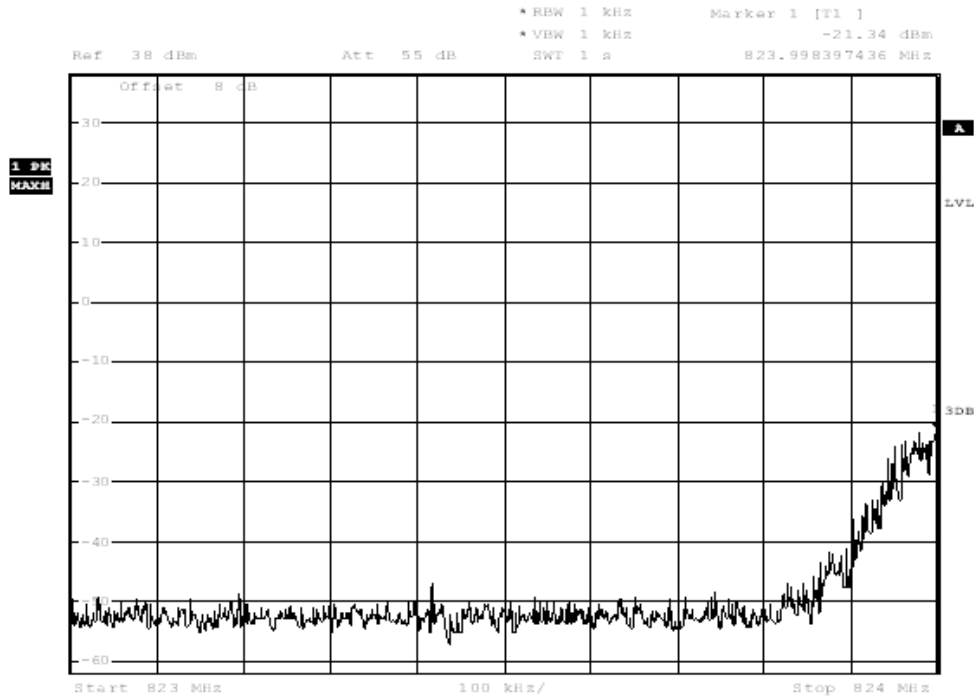

Date: 29.FEB.2012 23:57:17

GSM channel 128 Left band edge

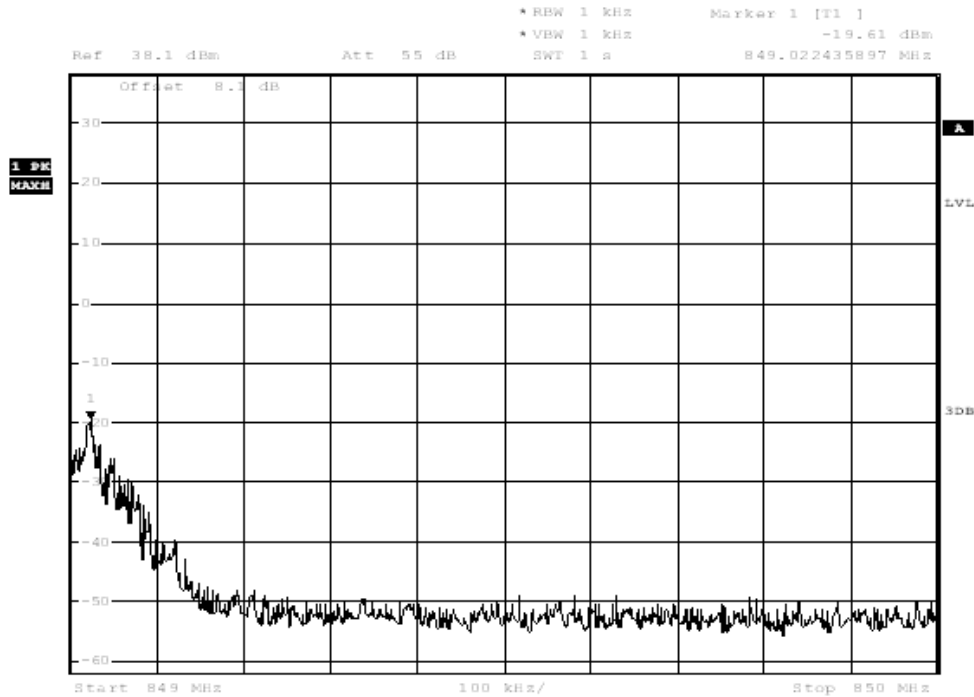

Date: 29.FEB.2012 23:57:32

GSM channel 251 Right band edge

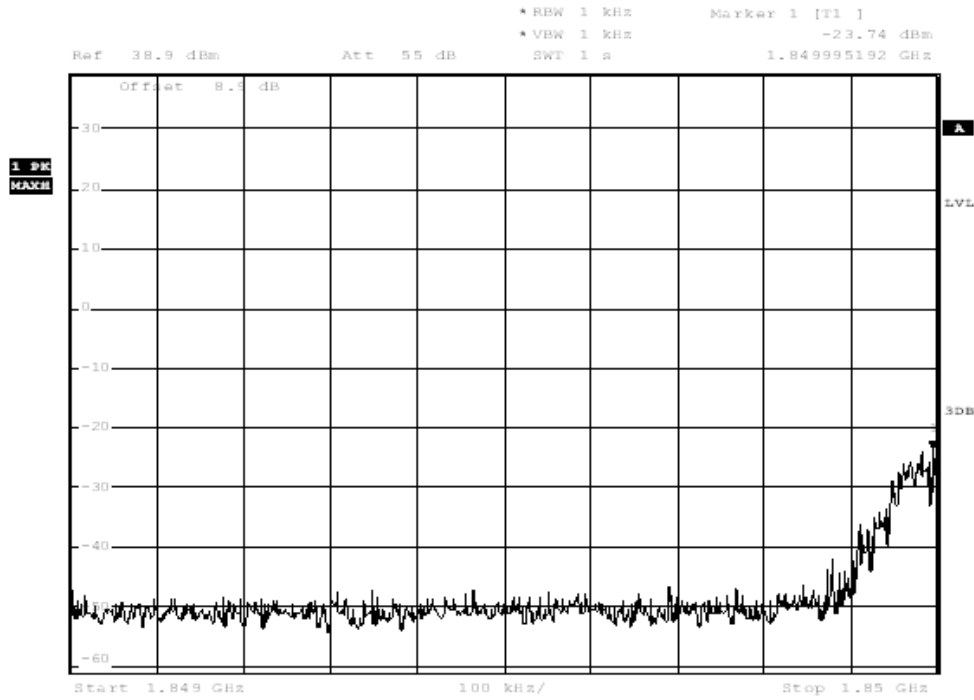

Date: 1.MAR.2012 00:18:29

### GSM channel 512 Left band edge

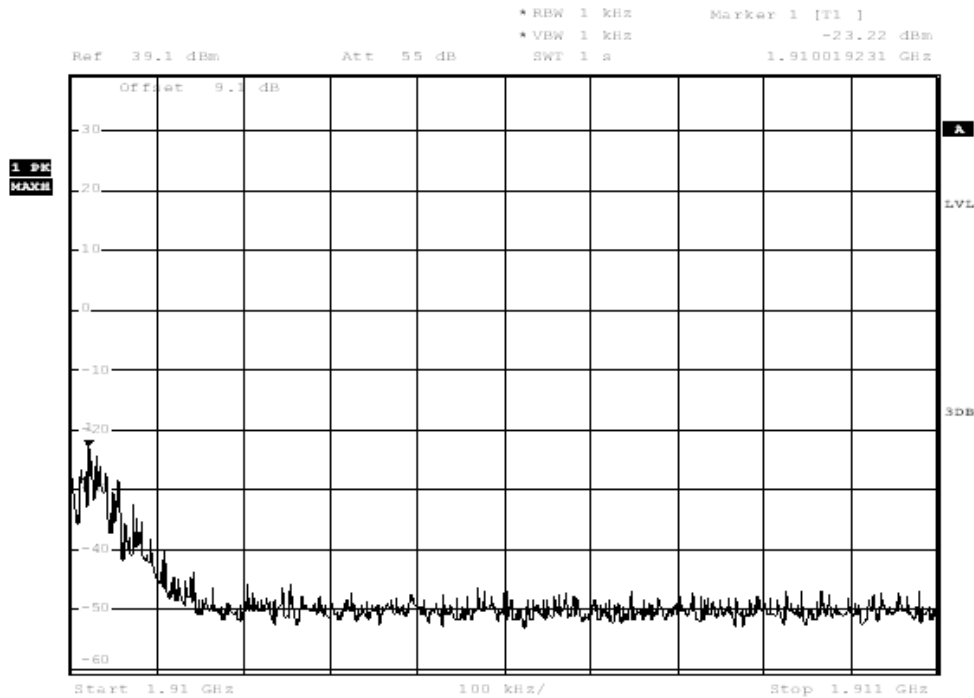

Date: 1.MAR.2012 00:18:44

### GSM channel 810 Right band edge

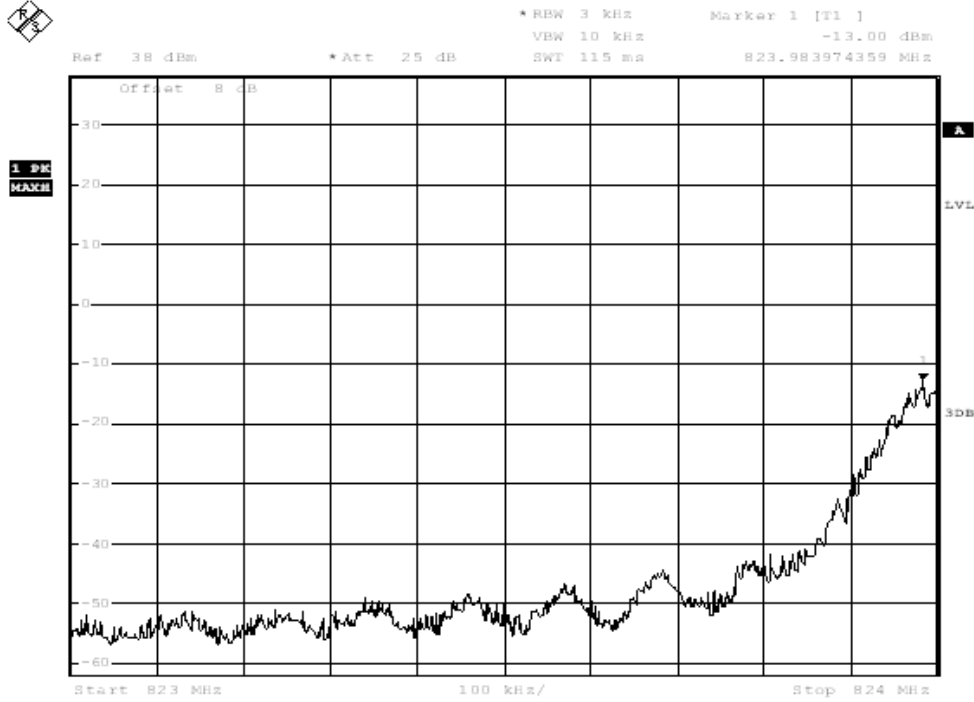

Date: 29.MAR.2012 17:53:57

### GPRS channel 128 Left band edge

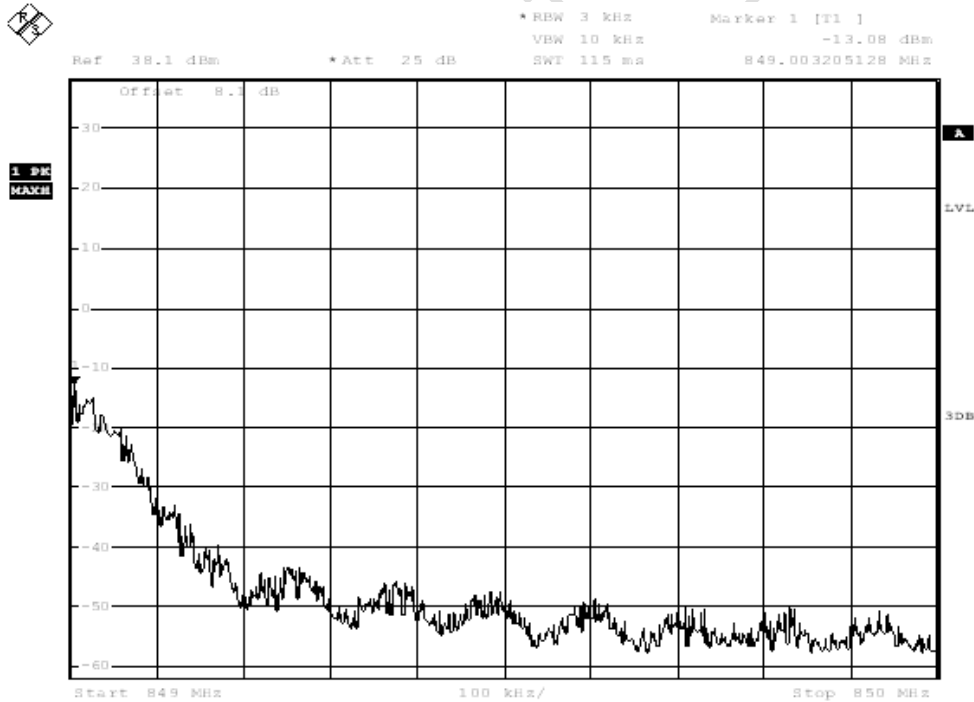

Date: 29.MAR.2012 17:54:12

### GPRS channel 251 Right band edge

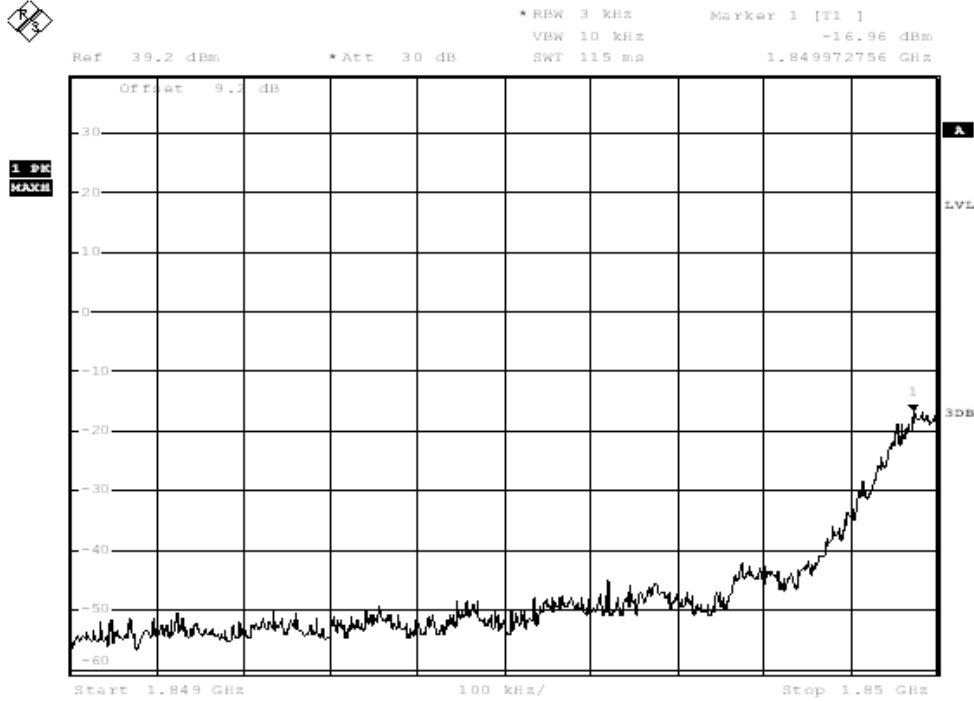

Date: 29.MAR.2012 01:33:23

### GPRS channel 512 Left band edge

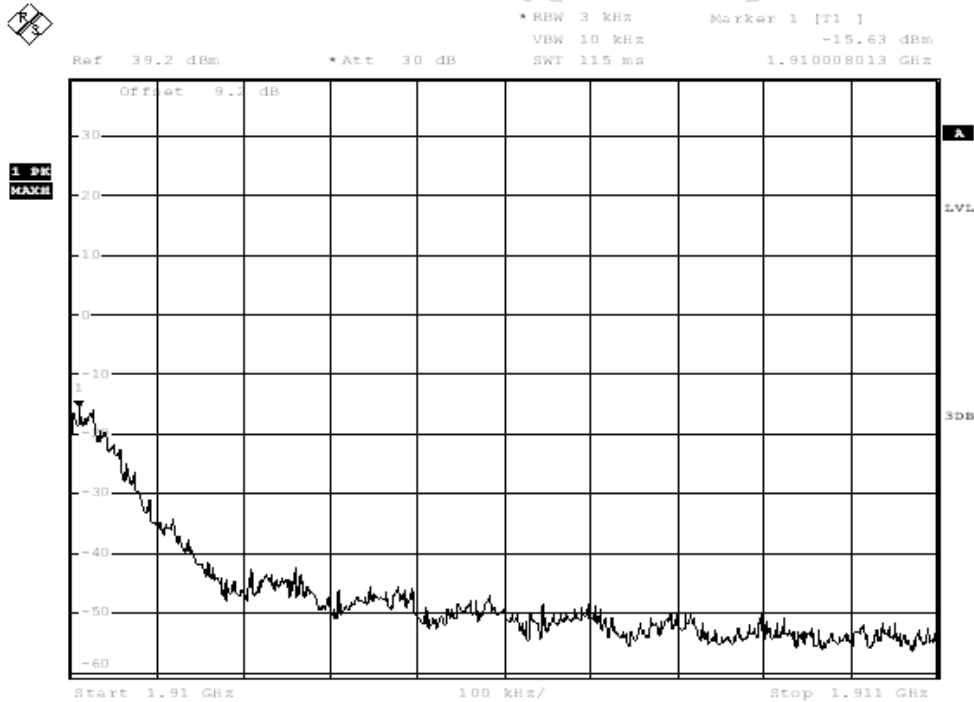

Date: 29.MAR.2012 01:33:37

### GPRS channel 810 Right band edge



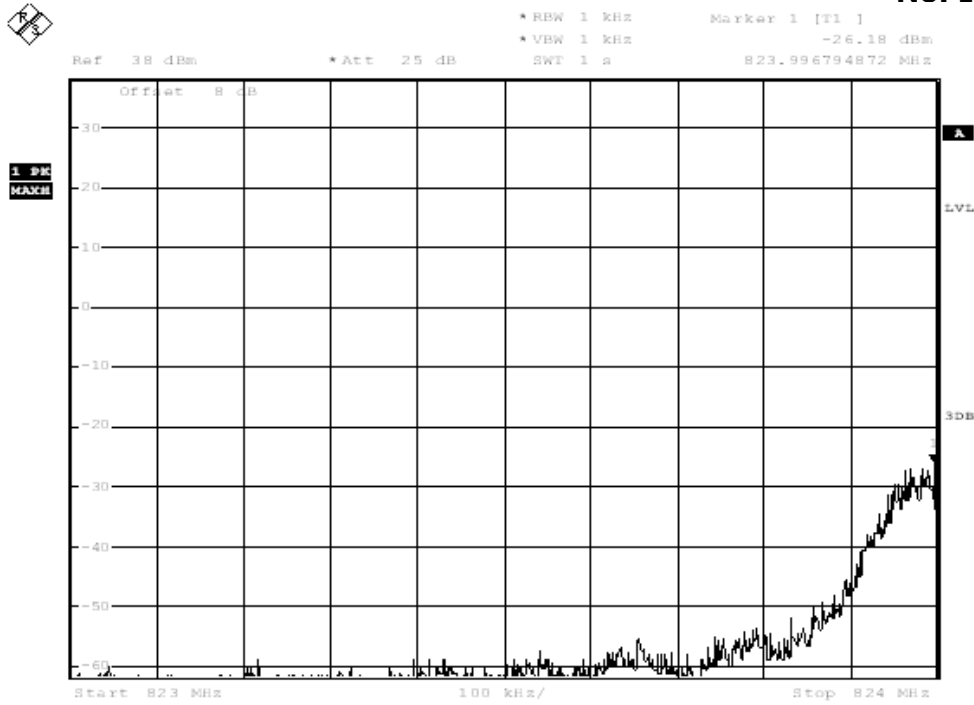

Date: 29.MAR.2012 17:39:37

### EGPRS channel 128 Left band edge

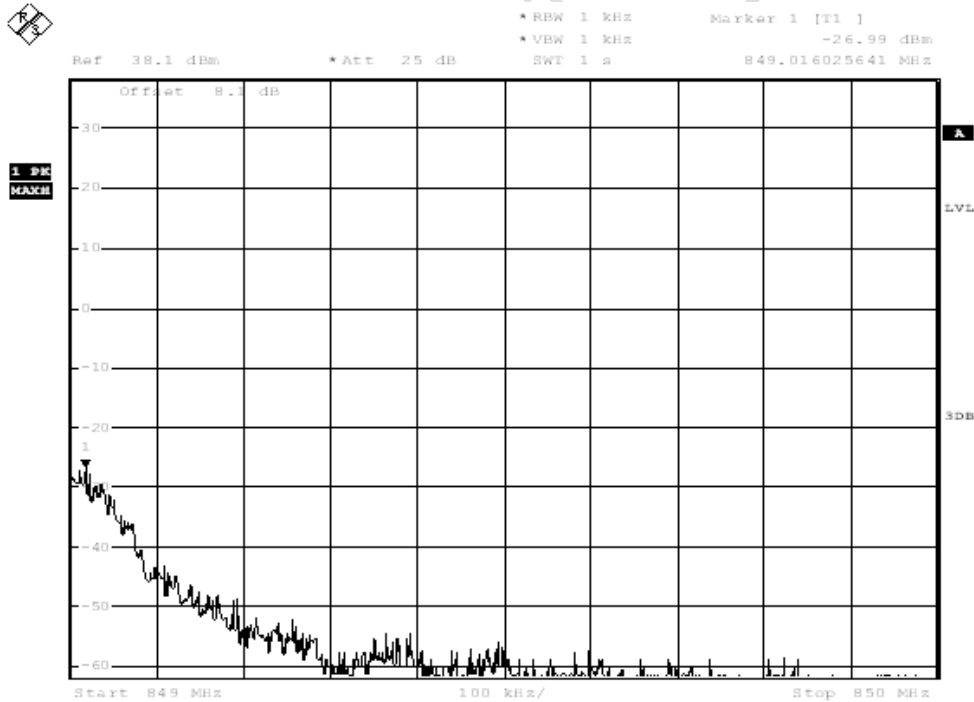

Date: 29.MAR.2012 17:39:52

### EGPRS channel 251 Right band edge

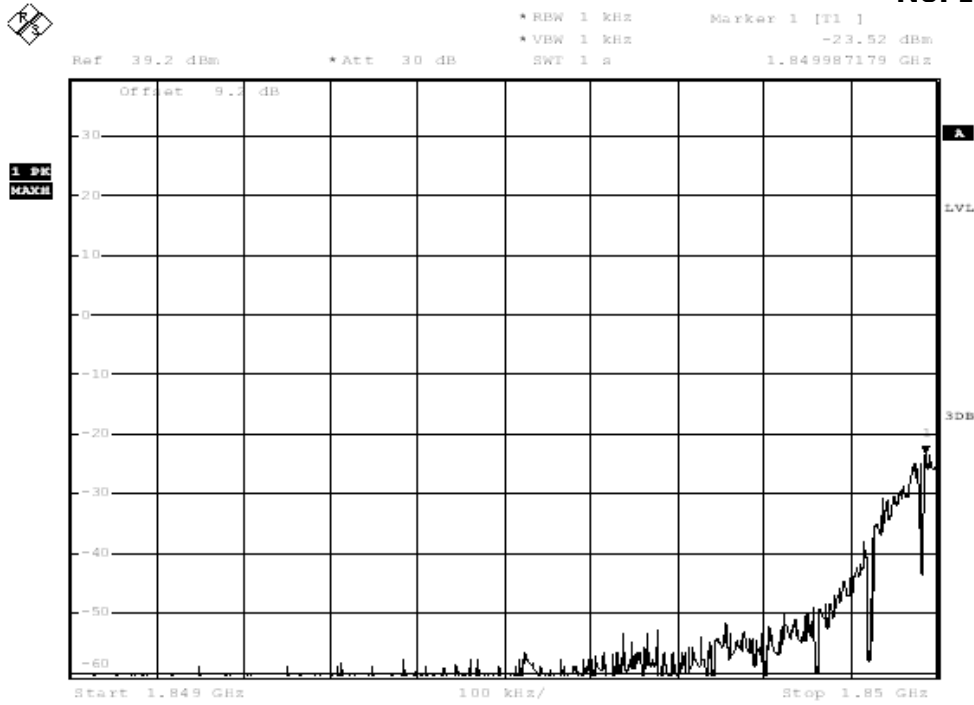

Date: 29.MAR.2012 01:39:06

### EGPRS channel 512 Left band edge

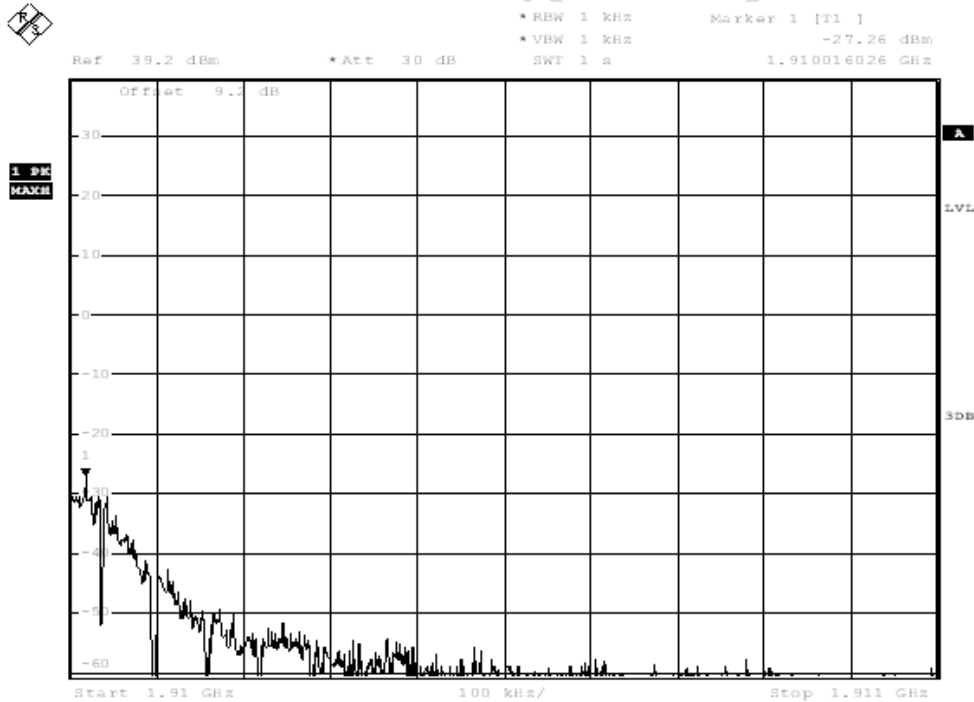

Date: 29.MAR.2012 01:39:21

### EGPRS channel 810 Right band edge

#### 4.9 Receiver Radiated Emission

<b>Specifications:</b>	15.109, 2.1053
<b>Test conditions:</b>	Ambient Temperature:15°C-35°C Relative Humidity:30%-60% Air pressure: 86-106kPa
<b>Operation Mode</b>	Idle
<b>Test Results:</b>	Pass

Limit		
Frequency of Emission (MHz)	Limit (dB $\mu$ V/m)	Measurement Distance (m)
30-88	30	10
88-216	33.5	10
216-960	36	10
960-1000	44	10
>1000	54	3

#### Test Setup

The Test Setup is similar as the setup of radiated spurious emission.

#### Test Method

The measurement procedure in ANSI C64.4-2003 is used. The EUT is placed on a 80 cm height non-conductive table locating on the center of turntable. From 30MHz-1GHz, the measurement distance is 10m. For frequency range above 1GHz, the measurement distance is 3m. The EUT is measured with travel charger and the operating mode is idle without CMU200's signaling.

Graphical test Result:

FCC Par t15 30MHz-1GHz

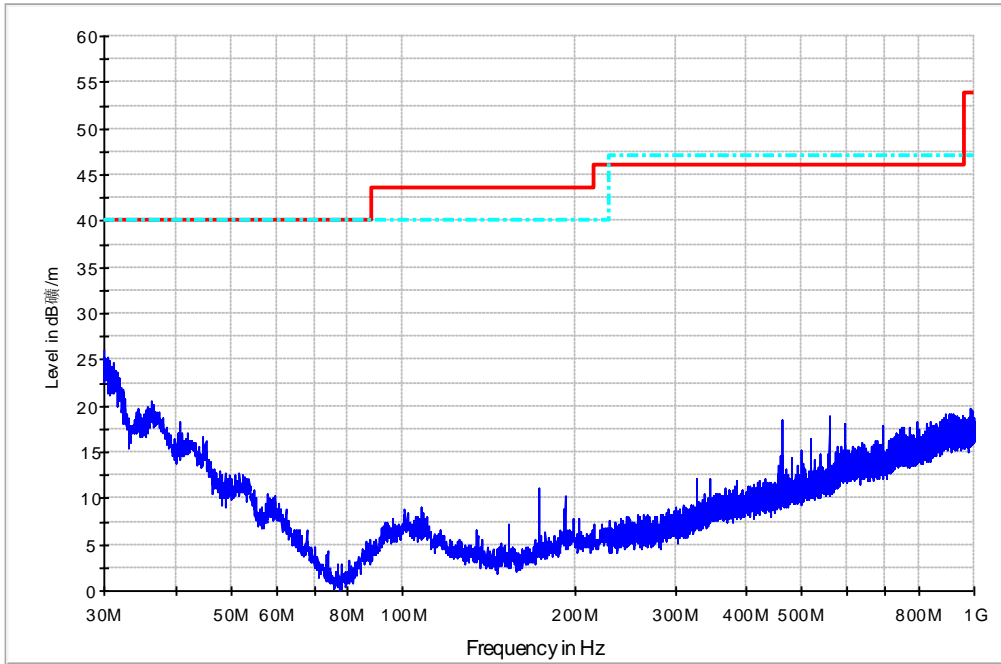

— FCC Class B Limit Line    — Preview Result 1    - - - Class B ITE at dist 3m

Idle mode: 30MHz-1GHz

FCC Par t15 EM I 1-4G

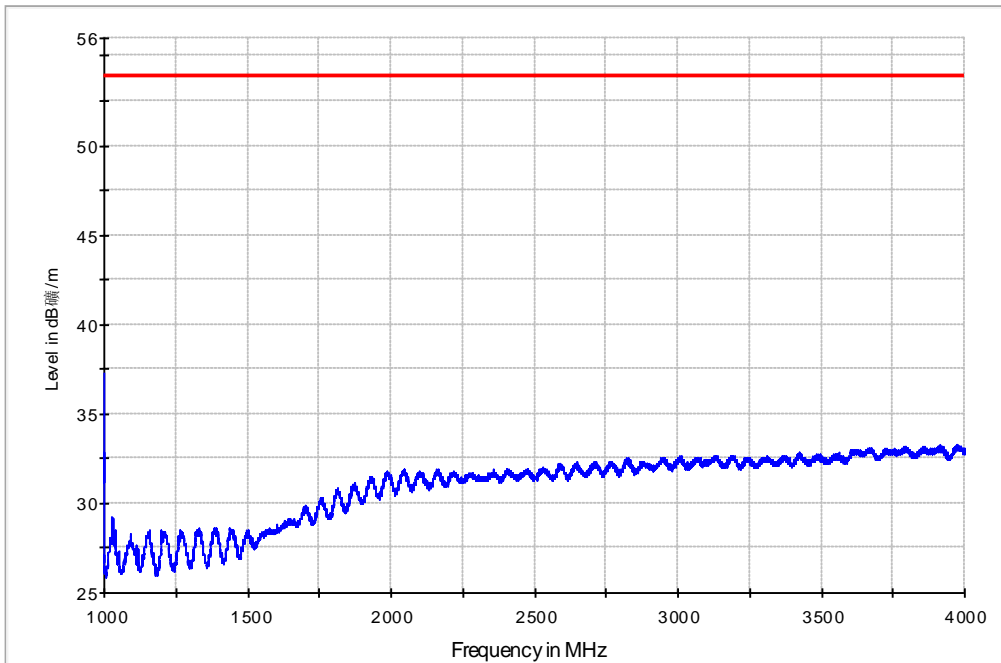

— FCC Class B Limit Line    — Preview Result 1

Idle mode: 1GHz-4GHz

FCC 4-18G

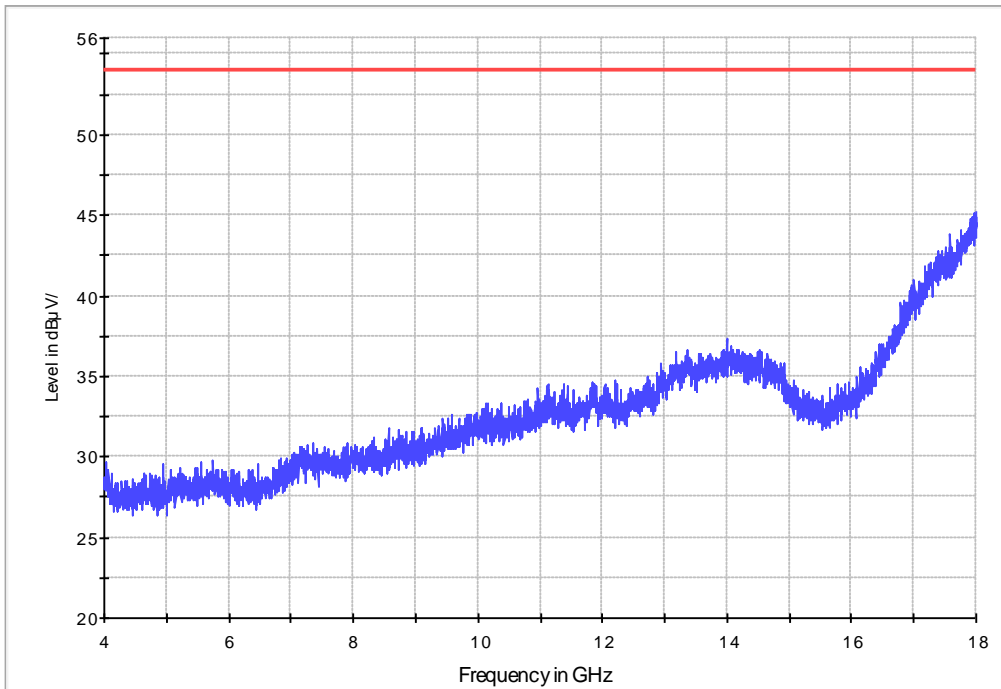

Idle mode: 4GHz-18GHz

CITL TEST

## 5 Test Equipments and Ancillaries Used For Tests

The test equipments and ancillaries used are as follows.

### 5.1 Test Equipments for RF Test

Ref No.	Instrument/ Ancillary	Type	Manufacturer	Serial No.	Cal Due Date
1	Universal Radio Communication Tester	CMU200	Rohde&Schwarz	114828	2013.01.19
2	Spectrum Analyzer	FSU	Rohde&Schwarz	200679	2013.01.18
3	Temperature Chamber	SH-241	ESPEC	92007516	2013.02.24
4	DC Power Supply	U3606A	Agilent Technologies	MY50450012	2013.11.15
5	RF Switch Matrix	OSP130	Rohde&Schwarz	100086	2013.03.28
6	Vector Signal Generator	SMU200A	Rohde&Schwarz	104072	2013.03.28
7	MXG Analog Signal Generator	N5183A	Agilent Technologies	MY50140012	2013.11.15

## 5.2 Test Equipments for RSE Test

Ref No.	Instrument/ Ancillary	Type	Manufacturer	Serial No.	Cal Due Date
1	Universal Radio Communication	CMU200	Rohde&Schwarz	114545	2013.03.23
2	Test Receiver	ESCI	Rohde&Schwarz	100701	2013.12.30
3	BiLog Antenna	9163	Schwarzbeck	9163-330	2014.03.02
4	Double-Ridged Waveguide Horn Antenna	3164-05	ETS-Lindgren	00085724	2014.02.18
5	Spectrum Analyzer	FSP40	Rohde&Schwarz	100378	2013.12.23
6	Fully Anechoic Chamber	n/a	ETS-Lindgren	n/a	2012.04.17

## Annex A External Photos



Front view



Back view





Adaptor and cable



battery

## **ANNEX B Deviations from Prescribed Test Methods**

No deviation from Prescribed Test Methods.

————— **The End of this Report** —————

*TTL Test Report*