

WIFI+BT Audio ModuleModelNo.型号: TWM-A8516+MD6630T

版本 Version: V1.2

公布日期 Release Date: 2017-11-28

TONLYELECTRONICS HOLDINGS LIMITED.通力电子控股有限公司

Address:Section 37,ZhongkaiHi-techDevelopmentZone, Huizhou Guangdong 516006, P.R.China

地址: 中国广东省惠州市仲恺高新区惠风6路37号小区网

址 <http://www.tonlyele.com>

WIFI+BT AudioModule

法律声明 LegalNotice, Disclaimer, Copyright

本手册是通力电子控股有限公司机密, 未经通力电子控股有限公司的事先书面许可, 任何人不得复制、传播本手册的内容。通力电子控股有限公司不对由于使用本手册或执行本手册内容带来的损害负责。

本手册所涉及的知识产权归通力电子控股有限公司所有 (或经合作商授权许可使用), 任何人不得侵犯。

本手册是按当前状态提供参考, 本公司保留随时更新本手册的权利, 恕不另行通知。本手册不对包括但不限于下列事项担保: 适销性、特殊用途的适应性; 实施该用途不会侵犯第三方的知识产权等权利。本文档在此未以禁止反言或其它方式授予任何知识产权使用许可, 不管是明示许可还是暗示许可。

本手册中提到的所有商标名称、商标和注册商标均属其各自所有者的财产, 特此声明。

本协议以中、英文两种语言制作, 两种语言文本冲突时, 任何时候均以中文为准。

This data sheet contains information that is confidential to TONLY ELECTRONICS HOLDINGS

LIMITED. Unauthorized use or disclosure of the information contained herein is prohibited. You may be held responsible for any loss or damages suffered by TONLY ELECTRONICS HOLDINGS LIMITED for your unauthorized disclosure hereof, in whole or in part.

Information herein is subject to change without notice. TONLY ELECTRONICS HOLDINGS LIMITED does not assume any responsibility for any use of, or reliance on, the information contained herein.

THIS DATA SHEET AND ALL INFORMATION CONTAINED HEREIN IS PROVIDED "AS IS" WITHOUT WARRANTY OF ANY KIND, WHETHER EXPRESS, IMPLIED, STATUTORY, OR OTHERWISE. TONLY ELECTRONICS HOLDINGS LIMITED SPECIFICALLY DISCLAIMS ALL IMPLIED WARRANTIES OF MERCHANTABILITY, NON-INFRINGEMENT, AND FITNESS FOR A PARTICULAR PURPOSE. NEITHER DOES TONLY ELECTRONICS HOLDINGS LIMITED PROVIDE ANY WARRANTY WHATSOEVER WITH RESPECT TO THE SOFTWARE OF ANY THIRD PARTY WHICH MAY BE USED BY, INCORPORATED IN, OR SUPPLIED WITH THIS DATA SHEET, AND USER AGREES TO LOOK ONLY TO SUCH THIRD PARTY FOR ANY WARRANTY CLAIM RELATING THERETO. TONLY ELECTRONICS HOLDINGS LIMITED SHALL ALSO NOT BE RESPONSIBLE FOR ANY TONLY ELECTRONICS HOLDINGS LIMITED DELIBERABLES MADE TO USER'S SPECIFICATION OR TO CONFORM TO A PARTICULAR STANDARD OR OPEN FORUM.

Tonly is a trademark of TONLY ELECTRONICS HOLDINGS LIMITED. Other names mentioned in this document are trademarks/registered trademark of their respective owners.

This data shall be executed in two languages including one Chinese and one English. Any conflict exist between the two languages, the Chinese will prevail in any time.

版本变更说明 Document Revision History

Revision 版本	Date 日期	Author 作者	Checkedby 审核	Description 描述
V1.0	2017-10-18	Tommy.li	JianliLiang	First release.
V1.1	2017-12-26	Tommy.li	JianliLiang	1.GPIODefine;IOPowerDomain adding. ThesemodifyarelimitedtoA,Dversion PCB.
V1.2	2018-01-10	Tommy.li	JianliLiang	1.USBDM1,DP1,LCMRST,DSITE Delete;2.AD1,AD2,AD3,Mi bias Portadding; These modifyare limited to DversionPCB.
V1.3	2018-03-29	Tommy.li	JianliLiang	1. Module Pin 46 function modify: GPIO117→GPIO73 2. Pin26,43,42,44Redefine pinname.

TONLY

Confidential

目录 Table of Contents

- 法律声明 Legal Notice, Disclaimer, Copyright
- 文档变更说明 Document Revision History
- 目录 Table of contents
- 1. 系统概览 System overview
 - 1.1 通用说明 General Descriptions
 - 1.2 性能特点 Features
 - 1.3 系统方框图 Block Diagram
- 2. 产品描述 Production Description
 - 引脚与功能说明 Pin Layout & Pin Description
 - 外观与尺寸 Appearance & Dimension
- 3. 应用说明 Application Explanation
- 4. 电气特性 Electrical Characteristics
 - 工作条件

- 直流特性 DC characteristics
- 热特性 Thermal characteristics
- 电流消耗 Current consumption
- 5.射频性能 RF Performance
- 6.认证与法规信息 Certificate& Regulation
- 7.包装与订货说明 Package& Ordering information
- 8.环保声明 GreenPolicy
- 9 推荐过炉温度 RECOMMENDEDTEMPERATURE REFLOWPROFILE
- 10.抗静电保护 ESDProtection

1. 系统概览 System overview

1.1 通用说明 General Descriptions

WiFi+BT Audio Module, The highly integrated module makes the possibilities of web browsing, VoIP, Bluetooth applications. With seamless roaming capabilities and advanced security, also could interact with different vendors'

802.11a/b/g/n Access Points in the wireless LAN. This compact module is a total solution for a combination of WiFi and Bluetooth V4.1 technologies.

1.2 性能特点 Features

- Supports 20/40MHz at 2.4GHz and 5GHz
- Supports Bluetooth V4.1+HS, BLE and be backwards compatible with Bluetooth 2.1+ enhanced data rate.
- Supports WLAN-Bluetooth coexistence and ISM-LTE coexistence.
- Supports Bluetooth for class 1 and class 2 power level transmissions without requiring an external PA.
- Audio Interfaces: I2S
- support microphone inputs (PDM digital microphone)
- Serial Interfaces: UART, SPI, I2C, USB
- Integrated PMU supports multiple low energy States
- Dimension: 56mm(L) × 41mm(W) × 2.54mm(H)

1.3 系统方框图 Module Block Diagram

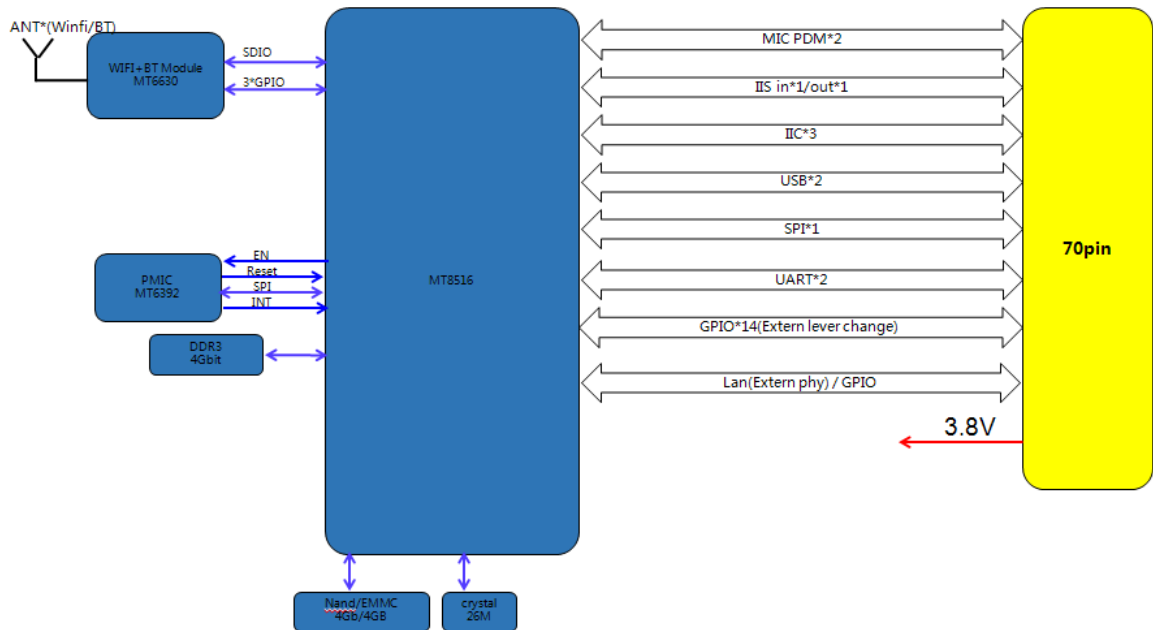

2. 产品描述 Production Description

引脚与功能说明 Apperance&PinDescription&PhysicalDimensions

- Description&Apperance:

Tonly confide

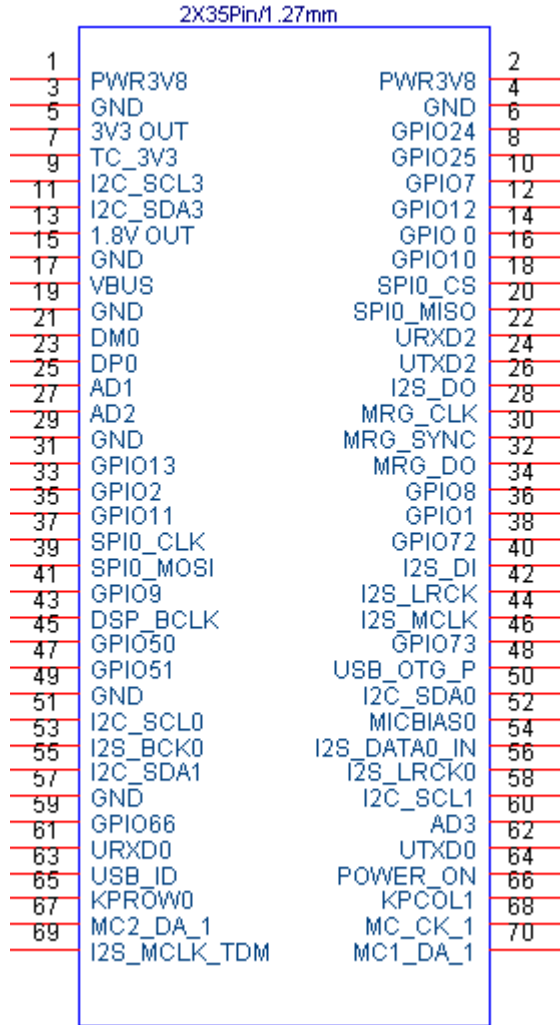

- Physical Dimensions

Tonly confidential

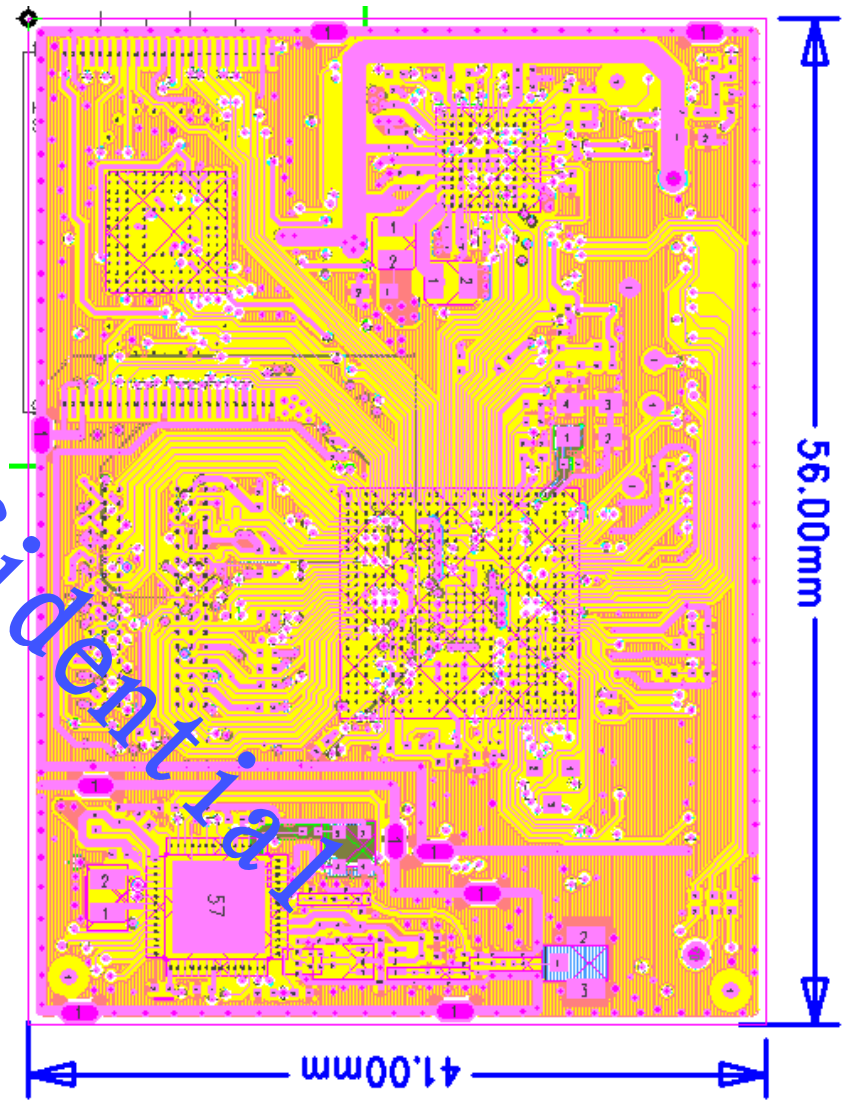

Pin header information

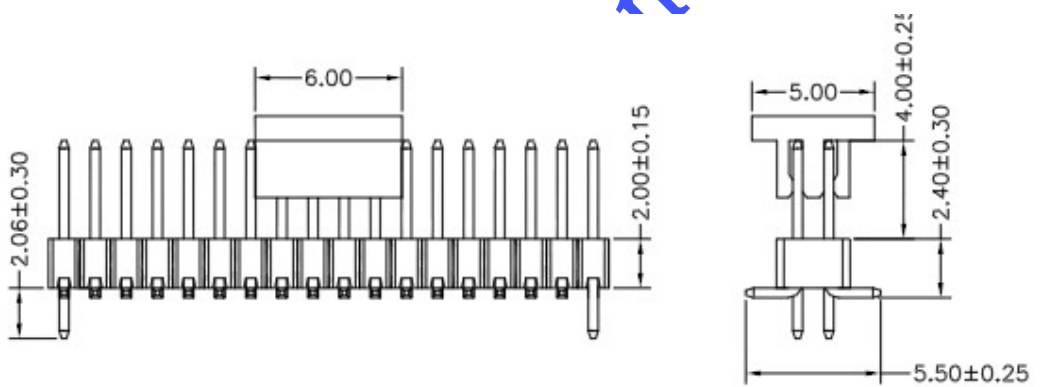
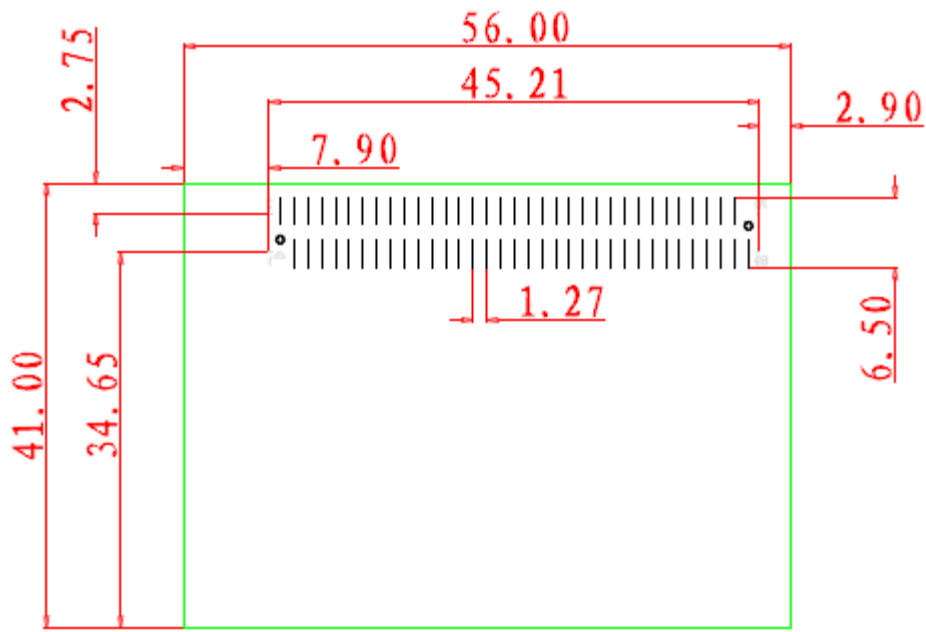

Pin descriptions

PIN NO.	Symbol	Description	Function
1	PWR3V8	Power input	VCC input, typical voltage range :3.6V ~4.2V
2	PWR3V8	Power input	VCC input, typical voltage range :3.6V ~4.2V
3	GND	ground	Ground
4	GND	ground	Ground
5	DSP_3V3	Power output	3.3V power supply
6	GPIO24	Bi-directional with 3.3V Power domain	<ul style="list-style-type: none"> ◆ GPIO24 ◆ Func_DPI_20; ◆ Func_DPI_DE

			<ul style="list-style-type: none"> ◆ Func_ANT_SEL1; ◆ Func_UCTS2; ◆ Func_PWM_A; ◆ Func_I2S_MCK; ◆ Func_DBG_Mon-A-O
7	TC_3V3	Power output	3.3Vpower supply
8	GPIO25	Bi-directional with 3.3V Power domain	<ul style="list-style-type: none"> ◆ FUNC_GPIO25. ◆ Func_I2S_8CH_MCK; ◆ Func_I2S_MCK; ◆ Func_DBG_Mon-A-1; ◆ Func_PWM_B; ◆ Func_URTS2; ◆ Func_ANT_SEL0; ◆ Func_DPI_VSYNC;Func_DPI_D19
9	I2C_SCL3	Bi-directional with 1.8V Power domain	<ul style="list-style-type: none"> ◆ Func_I2C_SCL2_0; ◆ GPIO61. ◆ Func_PWM_C
10	GPIO7	Bi-directional with 3.3V Power domain	<ul style="list-style-type: none"> ◆ FUNC_GPIO7; ◆ Func_SQIRST; ◆ Func_DPI_D6; ◆ Func_SDA1_0; ◆ Func_EXT_RXDV; ◆ Func_CONN_MCU_TMS; ◆ FUNC_CON_MCU_AICE_JMSC; ◆ FUNC_DBG_MON_A_13
11	I2C_SDA3	Bi-directional with 1.8V Power domain	<ul style="list-style-type: none"> ◆ FUNC_SDA2_0 ◆ GPIO60 ◆ FUNC_PWM_B
12	GPIO12	Bi-directional with 3.3V Power domain	<ul style="list-style-type: none"> ◆ FUNC_GPIO12; ◆ FUNC_CLKM5;FUNC_PWM_A; ◆ FUNC_SPDIF_OUT; ◆ FUNC_ANT_SEL4; ◆ FUNC_DPI_D11; ◆ FUNC_EXT_TXEN;FUNC_DBG_MON_A_18.
13	1.8V OUT	Power output	1.8Vpower supply
14	GPIO0	Bi-directional with 3.3V Power domain	<ul style="list-style-type: none"> ◆ FUNC_GPIO 0 ◆ FUNC_PWM_B; ◆ FUNC_DPI_CK;

			<ul style="list-style-type: none"> ◆ FUNC_I2S2_BCK; ◆ FUNC_EXT_TXD0; ◆ FUNC_SQICS; ◆ FUNC_DBG_MON_A_6
15	GND	ground	Ground
16	GPIO10	Bi-directional with 3.3V Power domain	<ul style="list-style-type: none"> ◆ FUNC_GPIO10 ◆ FUNC_CLKM5 ◆ FUNC_SCL2_0 ◆ FUNC_EXT_FRAME_SYNC ◆ FUNC_EXT_RXD2 ◆ FUNC_ANT_SEL2 ◆ FUNC_DPI_D9 ◆ FUNC_DBG_MON_A_16
17	VBUS	Power input	USB +5V input
18	SPI0_CS	Bi-directional with 3.3V Power domain	<ul style="list-style-type: none"> ◆ FUNC_SPI_CS ◆ FUNC_GPIO5 ◆ FUNC_UCTS2 ◆ FUNC_DPI_D16 ◆ FUNC_EXT_RXER ◆ FUNC_CONN_MCU_TDI ◆ FUNC_CONN_TEST_CK ◆ FUNC_DBG_MON_A_11
19	AGND	ground	Ground
20	SPI0_MISO	Bi-directional with 3.3V Power domain	<ul style="list-style-type: none"> ◆ FUNC_GPIO 3; ◆ FUNC_CLKM1; ◆ FUNC_DPI_D14; ◆ FUNC_SPI_MI; ◆ FUNC_EXT_TXD3; ◆ FUNC_CONN_MCU_DBGI_N; ◆ FUNC_SQIWP; ◆ FUNC_DBG_MON_A_9
21	DM0	Bi-directional	USB data minus.
22	URXD2	Bi-directional with 3.3V Power domain	<ul style="list-style-type: none"> ◆ FUNC_URXD2; ◆ FUNC_GPIO 34 ◆ FUNC_DPI_D5 ◆ FUNC_UTXD2 ◆ URXD2__FUNC_DBG_SCL ◆ FUNC_I2S2_MCK ◆ FUNC_DBG_MON_B_0
23	DP0	Bi-directional	USB data plus
24	UTXD2	Bi-directional with 3.3V Power domain	<ul style="list-style-type: none"> ◆ FUNC_UTXD2; ◆ FUNC_GPIO 35;

			<ul style="list-style-type: none"> ◆ FUNC_DPI_HSYNC; ◆ FUNC_URXD2; ◆ FUNC_DBG_SDA; ◆ FUNC_DPI_D18; ◆ FUNC_I2S3_MCK; ◆ FUNC_DBG_MON_B_1.
25	AD1	Bi-directional	<ul style="list-style-type: none"> ◆ Auxadexternal input channel2 power levelfull scale is1.45V.
26	I2S_DO	Bi-directional with 3.3V Power domain	<ul style="list-style-type: none"> ◆ FUNC_GPIO38; ◆ FUNC_MRG_DI ◆ FUNC_DPI_D1 ◆ FUNC_I2S0_DI ◆ FUNC_I2S3_DO ◆ FUNC_PCM0_DI ◆ FUNC_EXT_MDIO ◆ FUNC_DBG_MON_A_4
27	AD2	Bi-directional	<ul style="list-style-type: none"> ◆ Auxadexternal input channel3 power levelfull scale is1.45V.
28	MRG_CLK	Bi-directional with 3.3V Power domain	<ul style="list-style-type: none"> ◆ FUNC_MRG_CLK ◆ FUNC_GPIO36 ◆ FUNC_DPI_D4 ◆ FUNC_I2S0_BCK ◆ FUNC_I2S3_BCK ◆ FUNC_PCM0_CLK ◆ FUNC_IR ◆ FUNC_DBG_MON_A_2
29	GND	ground	Ground
30	MRG_SYNC	Bi-directional with 3.3V Power domain	<ul style="list-style-type: none"> ◆ FUNC_MRG_SYNC; ◆ FUNC_GPIO37; ◆ FUNC_DPI_D3; ◆ FUNC_I2S0_LRCK ◆ FUNC_I2S3_LRCK ◆ FUNC_PCM0_SYNC ◆ FUNC_EXT_COL ◆ FUNC_DBG_MON_A_3
31	GPIO13	Bi-directional with 3.3V Power domain	<ul style="list-style-type: none"> ◆ FUNC_GPIO13 ◆ FUNC_TSF_IN; ◆ FUNC_ANT_SEL5; ◆ FUNC_DPI_D0; ◆ FUNC_SPDIF_IN; ◆ FUNC_DBG_MON_A_19.
32	MRG_DO	Bi-directional with 3.3V Power domain	<ul style="list-style-type: none"> ◆ FUNC_MRG_DO ◆ FUNC_GPIO39 ◆ FUNC_DPI_D2

			<ul style="list-style-type: none"> ◆ FUNC_I2S0_MCK ◆ FUNC_I2S3_MCK ◆ FUNC_PCM0_DO ◆ FUNC_EXT_MDC ◆ FUNC_DBG_MON_A_5
33	GPIO2	Bi-directional with 3.3V Power domain	<ul style="list-style-type: none"> ◆ FUNC_GPIO2 ◆ FUNC_CLKM0; ◆ FUNC_DPI_D13; ◆ FUNC_I2S2_LRCK; ◆ FUNC_EXT_TXD2 ◆ FUNC_CONN_MCU_DBGACK_N; ◆ FUNC_SQISI; ◆ FUNC_DBG_MON_A_8
34	GPIO8	Bi-directional with 3.3V Power domain	<ul style="list-style-type: none"> ◆ FUNC_GPIO8; ◆ FUNC_SQICK; ◆ FUNC_CLKM3; ◆ FUNC_SCL1_0; ◆ FUNC_EXT_RXD0; ◆ FUNC_ANT_SELO; ◆ FUNC_DPI_D7; ◆ FUNC_DBG_MON_A_14.
35	GPIO11	Bi-directional with 3.3V Power domain	<ul style="list-style-type: none"> ◆ FUNC_GPIO11; ◆ FUNC_PWM_C; ◆ FUNC_ANT_SEL3; ◆ FUNC_CLKM4.
36	GPIO1	Bi-directional with 3.3V Power domain	<ul style="list-style-type: none"> ◆ FUNC_GPIO1; ◆ FUNC_PWM_C; ◆ FUNC_DPI_D12; ◆ FUNC_I2S2_DI; ◆ FUNC_EXT_TXD1; ◆ FUNC_CONN_MCU_TDO; ◆ FUNC_SQISO; ◆ FUNC_DBG_MON_A_7
37	SPI0_CLK	Bi-directional with 3.3V Powerdomain	<ul style="list-style-type: none"> ◆ FUNC_SPI0-CLK; ◆ FUNC_GPIO6. ◆ FUNC_DBG_MON_A_12
38	GPIO72	Bi-directional with 3.3V Powerdomain	<ul style="list-style-type: none"> ◆ FUNC_GPIO72; ◆ FUNC_MSDC2_DAT2; ◆ FUNC_I2S_8CH_LRCK; ◆ FUNC_DPI_D23; ◆ FUNC_PWM_C;

			<ul style="list-style-type: none"> ◆ FUNC_DBG_MON_B_19
39	SPI0_MOSI	Bi-directional with 3.3V Power domain	<ul style="list-style-type: none"> ◆ FUNC_SP0_MOSI; ◆ FUNC_GPIO4.
40	I2S_DI	Bi-directional with 3.3V Powerdomain	<ul style="list-style-type: none"> ◆ FUNC_I2S3_DO; ◆ FUNC_GPIO70; ◆ FUNC_MSDC2_DAT0; ◆ FUNC_I2S_8CH_DO2; ◆ FUNC_DPI_D22; ◆ FUNC_UTXD0; ◆ FUNC_DBG_MON_B_17
41	GPIO9	Bi-directional with 3.3V Power domain	<ul style="list-style-type: none"> ◆ FUNC_GPIO9 ◆ FUNC_CLKM4; ◆ FUNC_SDA2_0; ◆ FUNC_EXT_FRAME_SYNC; ◆ FUNC_EXT_RXD1; ◆ FUNC_ANT_SEL1; ◆ FUNC_DPI_D8; ◆ FUNC_DBG_MON_A_15.
42	I2S_LRCK	Bi-directional with 3.3V Power domain	<ul style="list-style-type: none"> ◆ FUNC_I2S3_LRCK; ◆ FUNC_GPIO69; ◆ FUNC_MSDC2_CLK; ◆ FUNC_I2S_8CH_DO3; ◆ FUNC_SCL1_0; ◆ FUNC_DPI_D21; ◆ FUNC_USB_SCL; ◆ FUNC_I2S3_LRCK; ◆ FUNC_DBG_MON_B_16
43	I2S_BCLK	Bi-directional with 3.3V Power domain	<ul style="list-style-type: none"> ◆ FUNC_I2S3_BCK; ◆ FUNC_GPIO68; ◆ FUNC_MSDC2_CMD; ◆ FUNC_I2S_8CH_DO4; ◆ FUNC_SDA1_0; ◆ FUNC_USB_SDA; ◆ FUNC_I2S3_BCK; ◆ FUNC_DBG_MON_B_15.
44	I2S_MCLK	Bi-directional with 3.3V Power domain	<ul style="list-style-type: none"> ◆ FUNC_I2S3_MCK; ◆ FUNC_GPIO71; ◆ FUNC_MSDC2_DAT1; ◆ FUNC_I2S_8CH_DO1; ◆ FUNC_PWM_A; ◆ FUNC_I2S3_MCK; ◆ FUNC_URXD0; ◆ FUNC_PWM_B; ◆ FUNC_DBG_MON_B_18.

45	GPIO50	Bi-directional with 1.8V Power domain	◆ FUNC_SPI_MISO ◆ FUNC_GPIO50
46	GPIO73	Bi-directional with 3.3V Power domain	◆ FUNC_I2S_8CH_BCK ◆ FUNC_GPIO73 ◆ FUNC_PWM_A
47	GPIO51	Bi-directional with 1.8V Power domain	◆ FUNC_SPI_MOSI ◆ FUNC_GPIO51
48	USB_OTG_P WR_EN	Bi-directional with 1.8V Power domain	◆ FUNC_GPIO49For USB_OTG_PWR_EN ◆ FUNC_SPI_CK
49	GND	ground	Ground
50	I2C_SDA0	Bi-directional with 1.8V Power domain	◆ FUNC_SDA0_0; ◆ FUNC_GPIO58.
51	I2C_SCL0	Bi-directional with 1.8V Power domain	◆ I2C_SCL0; ◆ FUNC_GPIO59.
52	MICBIAS0	Power output	Microphone bias A
53	I2S_BCK0	Bi-directional with 1.8V Power domain	◆ FUNC_I2S0_BCK; ◆ FUNC_GPIO57; ◆ FUNC_URTS0; ◆ FUNC_I2S3_BCK; ◆ FUNC_I2S_8CH_BCK; ◆ FUNC_PWM_C; ◆ FUNC_I2S2_LRCK; ◆ FUNC_DBG_MON_A_30
54	I2S_DATA0_ IN	Bi-directional with 1.8V Power domain	◆ FUNC_I2S3_DO; ◆ FUNC_GPIO55; ◆ FUNC_I2S0_DI; ◆ FUNC_UCTS0; ◆ FUNC_I2S_8CH_DO1; ◆ FUNC_PWM_A; ◆ FUNC_I2S2_BCK; ◆ FUNC_DBG_MON_A_28.
55	I2C_SDA1	Bi-directional with 1.8V Power domain	◆ FUNC_SDA1_0; ◆ FUNC_GPIO52.
56	I2S_LRCK0	Bi-directional with 1.8V Power domain	◆ FUNC_I2S0_LRCK; ◆ FUNC_GPIO56; ◆ FUNC_I2S3_LRCK; ◆ FUNC_I2S_8CH_LRCK; ◆ FUNC_PWM_B; ◆ FUNC_I2S2_DI; ◆ FUNC_DBG_MON_A_29
57	GND	ground	Ground
58	I2C_SCL1	Bi-directional with 1.8V Power domain	◆ FUNC_SCL1_0; ◆ FUNC_GPIO53

59	GPIO66	Bi-directional with 1.8V Power domain	◆ FUNC_I2S0_MCK
60	AD3	Bi-directional	◆ Auxadexternal input channel3 power levelfull scale is1.45V.
61	URXD0	Bi-directional with 1.8V Power domain	◆ FUNC_GPIO62; ◆ FUNC_URXD0; ◆ FUNC_UTXD0.
62	UTXD0	Bi-directional with 1.8V Power domain	◆ FUNC_GPIO63; ◆ FUNC_UTXD0; ◆ FUNC_URXD0
63	USB_ID	Bi-directional with 1.8V Power domain	◆ FUNC_GPIO41 ◆ FUNC_KPROW1; ◆ FUNC_IDDIG; ◆ FUNC_EXT_FRAME_SYNC; ◆ FUNC_MFG_TEST_CK; ◆ FUNC_DBG_MON_B_5.
64	POWER_ON	PWR	◆ Power Key, active low.
65	KPROW0	Bi-directional with 1.8V Power domain	◆ FUNC_KPROW0; ◆ FUNC_GPIO40; ◆ FUNC_IMG_TEST_CK; ◆ FUNC_DBG_MON_B_4.
66	GPIO43	Bi-directional with 1.8V Power domain	◆ FUNC_GPIO43; ◆ FUNC_KPCOL1; ◆ FUNC_USB_DRVVBUS; ◆ FUNC_EXT_FRAME_SYNC; ◆ FUNC_TSF_IN; ◆ FUNC_DFD_NTRST_XI; ◆ FUNC_UDI_NTRST_XI; ◆ FUNC_DBG_MON_B_7;
67	MC2_DA_1	PDM digital microphone	Digital microphoneData2
68	MC_CK_1	PDM digital microphone	Digital microphoneClk
69	I2S_MCLK_ TDM	Bi-directional with 1.8V Power domain	◆ FUNC_TDM_RX_MCK; ◆ FUNC_GPIO100; ◆ FUNC_CMDAT0; ◆ FUNC_CMCS0; ◆ FUNC_ANT_SEL2; ◆ FUNC_TDM_RX_MCK; ◆ FUNC_DBG_MON_B_21
70	MC1_DA_1	PDM digital microphone	Digital microphoneData1

Remark: Boldness is the default function by Tonly's software.

3.应用说明 Application Explanations

- All portable Smart devices

3.1 Application Block Diagram

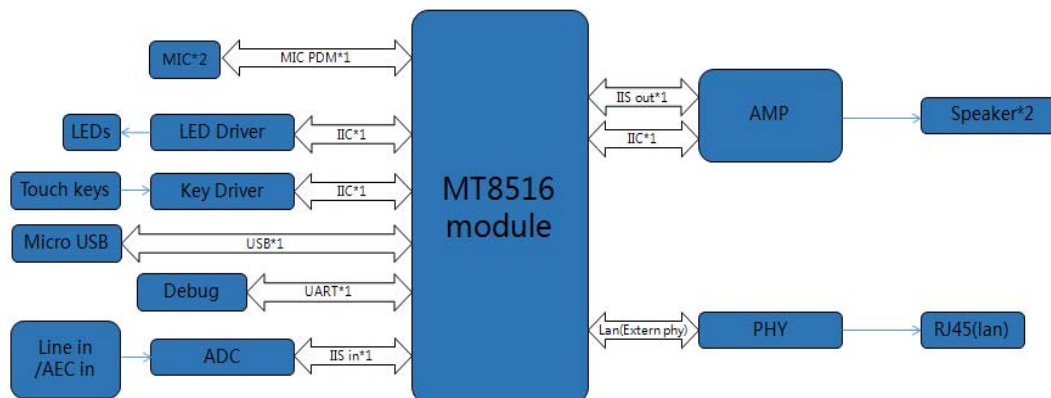

4. 电气特性 Electrical Characteristics

Base Characteristics

ELECTRICAL CHARACTERISTICS	
Supply Voltage	3.8VDC (Absolute Maximum Ratings 4.2V)
Working current	RMS 300mA
Sleep current	33mA
WEIGHT AND DIMENSIONS (unit : mm)	
Size (LxWxH)	56mm(L) × 41mm(W) × 1.6mm(H)
Weight	~8.5g

Recommended operating conditions

Recommended operating conditions	Min	Max	Unit
Operating temperature	-10	60	°C
PWR3V8	3.6	4.2	V

5. 射频性能 RF Performance

2.4G WIFI

		DATA rate (Mbps)	Test Item	Unit	TYPE	SPEC
2.4G	TX	All data rates	Freq. error	ppm	+/- 10	<+/-20
		802.11b, 1~11 Mbps DSSS	Power (RMS)	dBm	16	16+/-2
			EVM (Peak)	%	25	<35
		802.11g, 6 ~18Mbps OFDM	Power (RMS)	dBm	15	15+/-2
		802.11g, 24~36 Mbps OFDM	Power (RMS)	dBm	15	15+/-2
		802.11g, 48 ~54Mbps OFDM	Power (RMS)	dBm	14	14+/-2
		802.11n, HT20 MCS0~2	Power (RMS)	dBm	15	15+/-2
		802.11n, HT20 MCS3~4	Power (RMS)	dBm	15	15+/-2
		802.11n, HT20 MCS5~7	Power (RMS)	dBm	14	14+/-2
		802.11n, HT40 MCS0~4	Power (RMS)	dBm	14	14+/-2
		802.11n, HT40 MCS5~7	Power (RMS)	dBm	13	13+/-2
		802.11g, 6 ~18Mbps OFDM	EVM	dB	-15	<-9
		802.11g, 24~36 Mbps OFDM	EVM	dB	-20	<-16
		802.11g, 54Mbps OFDM	EVM	dB	-28	<-25
		802.11n, HT20 MCS0~2	EVM	dB	-15	≤-9
		802.11n, HT20 MCS3~4	EVM	dB	-20	≤-16
		802.11n, HT20 MCS5~7	EVM	dB	-30	≤-27
		802.11n, HT40 MCS0~4	EVM	dB	-19	≤-9
	802.11n, HT40 MCS5~7	EVM	dB	-30	≤-27	
	RX	CCK 1M	Sensitivity	dBm	-91	
		CCK 2M			-90	
		CCK 5.5M			-88	
		CCK 11M			-84	
		OFDM 6M			-88	
OFDM 9M		-85				

		OFDM 12M			-83	
		OFDM 18M			-81	
		OFDM 24M			-79	
		OFDM 48M			-74	
		OFDM 54M			-71	
		HT20 MCS0			-70	
		HT20 MCS1			-85	
		HT20 MCS2			-82	
		HT20 MCS3			-80	
		HT20 MCS4			-77	
		HT20 MCS5			-70	
		HT20 MCS6			-69	
		HT20 MCS7			-68	
		HT40 MCS0			-85	
		HT40 MCS1			-82	
		HT40 MCS2			-80	
		HT40 MCS3			-77	
		HT40 MCS4			-73	
		HT40 MCS5			-69	
		HT40 MCS6			-68	
		HT40 MCS7			-67	

5G WIFI

		DATA rate (Mbps)	Test Item	Unit	TYPE	SPEC
5G	TX	All data rates	Freq. error	ppm	+/- 10	<+/-20
		802.11a, 6 ~18Mbps OFDM	Power (RMS)	dBm	15	15+/-2
		802.11a,24~36 MbpsOFDM	Power (RMS)	dBm	14	14+/-2
		802.11a,48~54 MbpsOFDM	Power (RMS)	dBm	14	14+/-2
		HT20 HT20 MCS0~2	Power (RMS)	dBm	15	15+/-2
		HT20 HT20 MCS3~4	Power (RMS)	dBm	15	15+/-2
		HT20 MCS5~MCS7	Power (RMS)	dBm	14	14+/-2
		HT40 MCS0~MCS4	Power (RMS)	dBm	15	15+/-2
		HT40 MCS5~MCS7	Power (RMS)	dBm	14	14+/-2
		802.11a, 6 ~18Mbps OFDM	EVM	dB	-15	<-9
		802.11a,24~36	EVM	dB	-20	<-16

		MbpsOFDM				
		802.11a,48~54 MbpsOFDM	EVM	dB	-28	<-25
		HT20 HT20 MCS0~2	EVM	dB	-15	≤-9
		HT20 HT20 MCS3~4	EVM	dB	-20	≤-16
		HT20 MCS5~MCS7	EVM	dB	-30	≤-27
		HT40 MCS0~MCS4	EVM	dB	-19	≤-9
		HT40 MCS5~MCS7	EVM	dB	-30	≤-27
	RX	OFDM 6M	Sensitivity	dBm	-89	
		OFDM 9M			-87	
		OFDM 12M			-87	
		OFDM 18M			-84	
		OFDM 24M			-81	
		OFDM 48M			-77	
		OFDM 54M			-73	
		HT20 MCS0			-72	
		HT20 MCS1			-89	
		HT20 MCS2			-87	
		HT20 MCS3			-83	
		HT20 MCS4			-80	
		HT20 MCS5			-77	
		HT20 MCS6			-72	
		HT20 MCS7			-71	
		HT20 MCS8			-70	
		HT40 MCS0			-86	
		HT40 MCS1			-83	
		HT40 MCS2			-80	
		HT40 MCS3			-77	
		HT40 MCS4			-74	
		HT40 MCS5			-70	
		HT40 MCS6			-68	
		HT40 MCS7			-67	
	HT40 MCS8	-63				
	HT40 MCS9	-61				

2.4G BT

BR				
Parameter	Description	Typ.	Unit	
Output power (RMS)	Atmax poweroutput Level	8	dBm	5.5±4
ICFT	Initial carrier frequency drift	±18	kHz	<±75
Carrier frequency drift	One slotpacket (DH1)	±10	kHz	<±25
	Three slotpacket (DH3)	±10	kHz	<±40
	Five slot packet (DH5)	±10	kHz	<±40
	Max. driftrate	10	kHz/50u s	<20
Receiver sensitivity	BER <0.1%	-90	dBm	
EDR				
Parameter	Description	Typ.	Unit	
Output power (RMS)	π/4 DQPSK	5	dBm	2.5±4
	8PSK	5	dBm	2.5±4
Frequency stability	ω0, π/4 DQPSK	±4	kHz	<±10
	ω0, 8PSK	±4	kHz	<±10
	ωi, π/4 DQPSK	±18	kHz	<±75
	ωi, 8PSK	±18	kHz	<±75
	ω0+ωi , π/4 DQPSK	±20	kHz	<±75
	ω0+ωi ,8PSK	±20	kHz	<±75

Modulation accuracy	RMS DEVM, $\pi/4$ DQPSK	8	%	<20
	RMS DEVM,8PSK	8	%	<13
	Peak DEVM, $\pi/4$ DQPSK	15	%	<35
	Peak DEVM, 8PSK	15	%	<25
Receiver sensitivity	$\pi/4$ DQPSK (BER < 0.01%)	-90	dBm	
	8PSK (BER < 0.01%)	-89	dBm	
LE				
Parameter	Description	Typ.	Unit	
Output power(*)	Atmax. power output level	5.5	dBm	5.5 \pm 4
Carrier frequency offset and drift	Frequency offset	± 10	kHz	< ± 150
	Frequency drift	± 10	kHz	< ± 50
	Max. driftrate	± 10	kHz/us	< ± 20
Parameter	Description	Typ.	Unit	
Receiver sensitivity (*)	PER < 30.8%	-90	dBm	

6. 认证与法规信息 Certification&Regulation

The Certification:

FCC&ICID、RED、SRRC、MIC PretestOK.

7. 包装与订货说明 Package& Ordering Information

AssemblyInformation

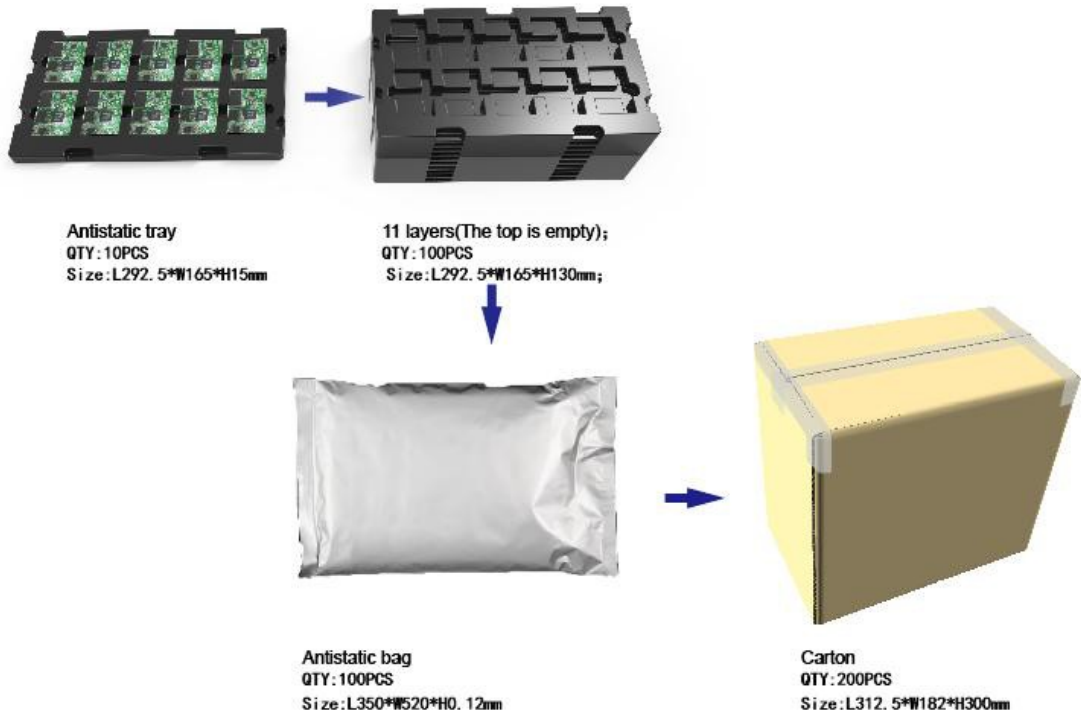

8.环保声明 Green Policy

This module can meet ROHS&REACH compliance.

9.推荐过炉温度 RECOMMENDED TEMPERATURE REFLOW PROFILE

NC

10.抗静电保护 ESD Protection



ESD CAUTION

TWM-A8516-MT6330T is ESD (electrostatic discharge) sensitive device and maybe

damaged with ESD or spike voltage. Although TWM-A8516-MT6330T is with built-in ESD protection circuits, please handle with care to avoid the permanent malfunction or the performance degradation.

FCC Statement

This device complies with part 15 of the FCC rules. Operation is subject to the following two conditions: (1) this device may not cause harmful interference, and (2) this device must accept any interference received, including interference that may cause undesired operation.

Changes or modifications not expressly approved by the party responsible for compliance could void the user's authority to operate the equipment.

NOTE: this equipment has been tested and found to comply with the limits for a Class B digital device, pursuant to part 15 of the FCC Rules. These limits are designed to provide reasonable protection against harmful interference in a residential installation. This equipment generates uses and can radiate radio frequency energy and, if not installed and used in accordance with the instructions, may cause harmful interference to radio communications. However, there is no guarantee that interference will not occur in a particular installation. If this equipment does cause harmful interference to radio or television reception, which can be determined by turning the equipment off and on, the user is encouraged to try to correct the interference by one or more of the following measures:

- Reorient or relocate the receiving antenna.
- Increase the separation between the equipment and receiver.
- Connect the equipment into an outlet on a circuit different from that to which the receiver is connected.
- Consult the dealer or an experienced radio/TV technician for help.

Important Note:

Radiation Exposure Statement

This equipment complies with FCC radiation exposure limits set forth for an uncontrolled environment. This equipment should be installed and operated with minimum distance 20 cm between the radiator and your body.

This transmitter must not be co-located or operating in conjunction with any other antenna or transmitter.

Country Code selection feature to be disabled for products marketed to the US/Canada.

1. The antenna must be installed such that 20 cm is maintained between the antenna and users, and
2. The transmitter module may not be co-located with any other transmitter or antenna.

As long as the three conditions above are met, further transmitter testing will not be required. However, the OEM integrator is still responsible for testing their end-product for any additional compliance requirements required with this module installed.

Important Note:

In the event that these conditions cannot be met (for example certain laptop configurations or co-location with another transmitter), then the FCC authorization is no longer considered valid and the FCC ID cannot be used on the final product. In these circumstances, the OEM integrator will be responsible for re-evaluating the end product (including the transmitter) and obtaining a separate FCC authorization.

End Product Labeling:

The final end product must be labeled in a visible area with the following "Contains FCC ID: ZVA10"

Manual Information to the End User:

The OEM integrator has to be aware not provide information to the end user regarding how to install or remove this RF module in the user's manual of the end product which integrates this module.

The end user manual shall include all required regulatory information/warning as show in this manual.

Antenna information

The TMW-A8516+MT6630T has been designed to pass certification with the antenna listed below. The required antenna impedance is 50 ohms.

Model	Type	Connector	Peak gain (dBi)				
			2400-2483.5 MHz	5150-5250 MHz	5250-5350 MHz	5470-5725 MHz	5725-5850 MHz
N/A	PIFA	RF-SMA	3.00	6.39	6.39	6.39	6.39

ISED Statement

- English: This device complies with Industry Canada license-exempt RSS standard(s).

Operation is subject to the following two conditions: (1) This device may not cause interference, and (2) This device must accept any interference, including interference that may cause undesired operation of the device. The digital apparatus complies with Canadian CAN ICES-3 (B)/NMB-3 (B).

- French: Le présent appareil est conforme aux CNR d'Industrie Canada applicables aux appareils radio exempts de licence. L'exploitation est autorisée aux deux conditions suivantes: (1) l'appareil ne doit pas produire de brouillage, et

(2) l'utilisateur de l'appareil doit accepter tout brouillage radioélectrique subi, même si le brouillage est susceptible d'en compromettre le fonctionnement.

This radio transmitter (ISED certification number: 9976A-10) has been approved by Industry Canada to operate with the maximum permissible gain indicated. Strictly prohibited for use with this device with maximum antenna gain.

Le présent émetteur radio (ISED certification number: 9976A-10) a été approuvée par Industrie Canada pour fonctionner avec le gain maximal indiqué. Strictement interdite pour utilisation avec ce dispositif avec le maximum de gain d'antenne.

Antenna information

The TMW-A8516+MT6630T has been designed to pass certification with the antenna listed below. The required antenna impedance is 50 ohms.

Model	Type	Connector	Peak gain (dBi)				
			2400-2483.5 MHz	5150-5250 MHz	5250-5350 MHz	5470-5725 MHz	5725-5850 MHz
N/A	PIFA	RF-SMA	3.0dBi	6.39	6.39	6.39	6.39

Radiation Exposure Statement

This equipment complies with Canada radiation exposure limits set forth for an uncontrolled environment. This equipment should be installed and operated with minimum distance 20 cm between the radiator and your body.

Déclaration d'exposition aux radiations

Cet équipement est conforme Canada limites d'exposition aux radiations dans un environnement non contrôlé. Cet équipement doit être installé et utilisé à distance minimum de 20cm entre le radiateur et votre corps.

This device is intended only for OEM integrators under the following condition:

The transmitter module may not be co-located with any other transmitter or antenna.

As long as the condition above is met, further transmitter test will not be required. However, the OEM integrator is still responsible for testing their end-product for any additional compliance requirements required with this module installed.

Cet appareil est conçu uniquement pour les intégrateurs OEM dans les conditions suivantes:

Le module émetteur peut ne pas être coïncidé avec un autre émetteur ou antenne.

Tant que les 1 condition ci-dessus sont remplies, des essais supplémentaires sur l'émetteur ne seront pas nécessaires. Toutefois, l'intégrateur OEM est toujours responsable des essais sur son produit final pour toutes exigences de conformité supplémentaires requis pour ce module installé.

Important Note:

In the event that these conditions cannot be met (for example certain laptop configurations or co-location with another transmitter), then the Canada authorization is no longer considered valid and the IC cannot be used on the final product. In these circumstances, the OEM integrator will be responsible for re-evaluating the end product (including the transmitter) and obtaining a separate Canada authorization.

Note Importante:

Dans les conditions ne peuvent être satisfaites (par exemple pour certaines configurations d'ordinateur portable ou de certaines co-localisation avec un autre émetteur), l'autorisation du Canada n'est plus considérée comme valide et l'IC ne peut pas être réutilisé sur le produit final. Dans certaines circonstances, l'intégrateur OEM sera chargé de réévaluer le produit final (y compris l'émetteur) et l'obtention d'une autorisation distincte au Canada.

End Product Labeling

The final end product must be labeled in a visible area with the following: Contains IC:9976A-10.

Plaque signalétique du produit final

Le produit final doit être étiqueté dans un endroit visible avec l'inscription suivante: Contient des IC:9976A-10.

Manual Information to the End User

The OEM integrator has to be aware not to provide information to the end user regarding how to install or remove this RF module in the user's manual of the end product which integrates this module.

The end user manual shall include all required regulatory information/warning as show in this manual.

Manuel d'information à l'utilisateur final

L'intégrateur OEM doit être conscient de ne pas fournir des informations à l'utilisateur final quant à la façon d'installer ou de supprimer ce module RF dans le manuel de l'utilisateur du produit final qui intègre ce module.

Le manuel de l'utilisateur final doit inclure toutes les informations réglementaires requises et avertissements comme indiqué dans ce manuel.

Caution:

- (i) The device for operation in the band 5150–5250 MHz is only for indoor use to reduce the potential for harmful interference to co-channel mobile satellite systems;
- (ii) For devices with detachable antenna(s), the maximum antenna gain permitted for devices in the bands 5250-5350 MHz and 5470-5725 MHz shall be such that the equipment still complies with the EIRP limit;
- (iii) For devices with detachable antenna(s), the maximum antenna gain permitted for devices in the band 5725-5850 MHz shall be such that the equipment still complies with the EIRP limits specified for point-to-point and non-point-to-point operation as appropriate; and operations in the 5.25-5.35GHz band are restricted to indoor usage only.

Avertissement:

- (i) les dispositifs fonctionnant dans la bande de 5150 à 5250 MHz sont réservés uniquement pour une utilisation à l'intérieur afin de réduire les risques de brouillage préjudiciable aux systèmes de satellites mobiles utilisant les mêmes canaux;
- (ii) pour les dispositifs munis d'antennes amovibles, le gain maximal d'antenne permis pour les dispositifs utilisant les bandes de 5250 à 5350 MHz et de 5470 à 5725 MHz doit être conforme à la limite de la p.i.r.e.;
- (iii) pour les dispositifs munis d'antennes amovibles, le gain maximal d'antenne permis (pour les dispositifs utilisant la bande de 5725 à 5850 MHz) doit être conforme à la limite de la p.i.r.e. spécifiée pour l'exploitation point à point et l'exploitation non point à point, selon le cas; Les opérations dans la bande de 5.25-5.35 GHz sont limitées à un usage intérieur seulement.

-----END-----