

FCC Radio Test Report

FCC ID: ZVA10

This report concerns (check one): Original Grant Class I Change Class II Change

Project No. : 1804C068
Equipment : WIFI+BT Audio Module
Model Name : TWM-A8516+MT6630T
Series Model : N/A
Applicant : TCL Technoly Electronics (Huizhou) Co., Ltd.
Address : Section 37, Zhongkai High-tech Development Zone,
Huizhou City, Guang Dong Province, P.R. China.

Date of Receipt : Apr. 12, 2018
Date of Test : Apr. 16, 2018 ~ May 03, 2018
Issued Date : May 21, 2018
Tested by : BTL Inc.

Testing Engineer : Jivey Jiang
(Jivey Jiang)

Technical Manager : shawn xiao
(Shawn Xiao)

Authorized Signatory : David Mao
(David Mao)

B T L I N C .

No.3, Jinshagang 1st Road, Shixia, Dalang Town, Dongguan,
Guangdong, China.

TEL: +86-769-8318-3000 FAX: +86-769-8319-6000



Declaration

BTL represents to the client that testing is done in accordance with standard procedures as applicable and that test instruments used has been calibrated with standards traceable to international standard(s) and/or national standard(s).

BTL's reports apply only to the specific samples tested under conditions. It is manufacture's responsibility to ensure that additional production units of this model are manufactured with the identical electrical and mechanical components. **BTL** shall have no liability for any declarations, inferences or generalizations drawn by the client or others from **BTL** issued reports.

BTL's report must not be used by the client to claim product certification, approval, or endorsement by NVLAP, NIST, or any agency of the Federal Government.

This report is the confidential property of the client. As a mutual protection to the clients, the public and **BTL-self**, extracts from the test report shall not be reproduced except in full with **BTL's** authorized written approval.

BTL's laboratory quality assurance procedures are in compliance with the **ISO Guide 17025** requirements, and accredited by the conformity assessment authorities listed in this test report.

Limitation

For the use of the authority's logo is limited unless the Test Standard(s)/Scope(s)/Item(s) mentioned in this test report is (are) included in the conformity assessment authorities acceptance respective.

Table of Contents

Page

1 . CERTIFICATION	6
2 . SUMMARY OF TEST RESULTS	7
2.1 TEST FACILITY	8
2.2 MEASUREMENT UNCERTAINTY	8
3 . GENERAL INFORMATION	9
3.1 GENERAL DESCRIPTION OF EUT	9
3.2 DESCRIPTION OF TEST MODES	12
3.3 TABLE OF PARAMETERS OF TEST SOFTWARE SETTING	14
3.4 BLOCK DIAGRAM SHOWING THE CONFIGURATION OF SYSTEM TESTED	16
3.5 DESCRIPTION OF SUPPORT UNITS	16
4 . EMC EMISSION TEST	17
4.1 CONDUCTED EMISSION MEASUREMENT	17
4.1.1 POWER LINE CONDUCTED EMISSION	17
4.1.2 TEST PROCEDURE	17
4.1.3 DEVIATION FROM TEST STANDARD	17
4.1.4 TEST SETUP	18
4.1.5 EUT OPERATING CONDITIONS	18
4.1.6 EUT TEST CONDITIONS	18
4.1.7 TEST RESULTS	18
4.2 RADIATED EMISSION MEASUREMENT	19
4.2.1 RADIATED EMISSION LIMITS	19
4.2.2 TEST PROCEDURE	20
4.2.3 DEVIATION FROM TEST STANDARD	20
4.2.4 TEST SETUP	20
4.2.5 EUT OPERATING CONDITIONS	21
4.2.6 EUT TEST CONDITIONS	21
4.2.7 TEST RESULTS (9K TO 30MHz)	22
4.2.8 TEST RESULTS (BETWEEN 30 TO 1000 MHz)	22
4.2.9 TEST RESULTS (ABOVE 1000 MHz)	22
5 . 26dB SPECTRUM BANDWIDTH	23
5.1 APPLIED PROCEDURES / LIMIT	23
5.1.1 TEST PROCEDURE	23
5.1.2 DEVIATION FROM STANDARD	23
5.1.3 TEST SETUP	23
5.1.4 EUT OPERATION CONDITIONS	23
5.1.5 EUT TEST CONDITIONS	24
5.1.6 TEST RESULTS	24
6 . MAXIMUM CONDUCTED OUTPUT POWER	25

Table of Contents	Page
6.1 APPLIED PROCEDURES / LIMIT	25
6.1.1 TEST PROCEDURE	25
6.1.2 DEVIATION FROM STANDARD	26
6.1.3 TEST SETUP	26
6.1.4 EUT OPERATION CONDITIONS	26
6.1.5 EUT TEST CONDITIONS	26
6.1.6 TEST RESULTS	26
7 . POWER SPECTRAL DENSITY TEST	27
7.1 APPLIED PROCEDURES / LIMIT	27
7.1.1 TEST PROCEDURE	27
7.1.2 DEVIATION FROM STANDARD	28
7.1.3 TEST SETUP	28
7.1.4 EUT OPERATION CONDITIONS	28
7.1.5 EUT TEST CONDITIONS	28
7.1.6 TEST RESULTS	28
8 . FREQUENCY STABILITY MEASUREMENT	29
8.1 APPLIED PROCEDURES / LIMIT	29
8.1.1 TEST PROCEDURE	29
8.1.2 DEVIATION FROM STANDARD	29
8.1.3 TEST SETUP	30
8.1.4 EUT OPERATION CONDITIONS	30
8.1.5 EUT TEST CONDITIONS	30
8.1.6 TEST RESULTS	30
9 . MEASUREMENT INSTRUMENTS LIST	31
10 . EUT TEST PHOTOS	33
APPENDIX A - CONDUCTED EMISSION	37
APPENDIX B - RADIATED EMISSION (9KHZ TO 30MHZ)	40
APPENDIX C - RADIATED EMISSION (30MHZ TO 1000MHZ)	45
APPENDIX D - RADIATED EMISSION (ABOVE 1000MHZ)	70
APPENDIX E - BANDWIDTH	206
APPENDIX F - MAXIMUM OUTPUT POWER	231
APPENDIX G - POWER SPECTRAL DENSITY	236
APPENDIX H - FREQUENCY STABILITY	261

REPORT ISSUED HISTORY

Issued No.	Description	Issued Date
BTL-FCCP-4-1804C068	Original Issue.	May 16, 2018
MDG1805036	Update the Conducted Emission.	May 21, 2018

1. CERTIFICATION

Equipment : WIFI+BT Audio Module
Brand Name : TCL
Model Name : TWM-A8516+MT6630T
Applicant : TCL Technoly Electronics (Huizhou) Co., Ltd.
Manufacturer: TCL Technoly Electronics (Huizhou) Co., Ltd.
Address : Section 37, Zhongkai High-tech Development Zone, Huizhou City, Guang Dong Province, P.R. China.
Factory : TCL Technoly Electronics (Huizhou) Co., Ltd.
Address : Section 37, Zhongkai High-tech Development Zone, Huizhou City, Guang Dong Province, P.R. China.
Date of Test : Apr. 16, 2018 ~ May 03, 2018
Test Sample : Engineering Sample NO.: D180403056.
Standard(s) : FCC Part15, Subpart E(15.407) / ANSI C63.10-2013

The above equipment has been tested and found compliance with the requirement of the relative standards by BTL Inc.

The test data, data evaluation, and equipment configuration contained in our test report (Ref No. BTL-FCCP-4-1804C068) were obtained utilizing the test procedures, test instruments, test sites that has been accredited by the Authority of NVLAP according to the ISO-17025 quality assessment standard and technical standard(s).

Test results included in this report is only for the RLAN 5G UNII-1, UNII-2A, UNII-2C, UNII-3 part.

2. SUMMARY OF TEST RESULTS

Test procedures according to the technical standard(s):

FCC Part15, Subpart E(15.407)			
Standard(s) Section	Test Item	Judgment	Remark
15.207	AC Power Line Conducted Emissions	PASS	
15.407(a)	26dB Spectrum Bandwidth	PASS	
15.407(a)	Maximum Conducted Output Power	PASS	
15.407(a)	Power Spectral Density	PASS	
15.407(a)	Radiated Emissions	PASS	
15.407(b)	Band Edge Emissions	PASS	
15.407(g)	Frequency Stability	PASS	
15.203	Antenna Requirements	PASS	

NOTE:

(1) "N/A" denotes test is not applicable in this test report.

2.1 TEST FACILITY

The test facilities used to collect the test data in this report is at the location of No.3,Jinshagang 1st Road, Shixia, Dalang Town, Dongguan, Guangdong, China.

BTL's test firm number for FCC: 854385

BTL's designation number for FCC: CN5020

2.2 MEASUREMENT UNCERTAINTY

The measurement uncertainty figures shall be calculated according the methods described in the ETSI TR 100 028 and shall correspond to an expansion factor (coverage factor) $k=1.96$ or $k=2$ (which provide confidence levels of respectively 90% and 95.45% in the case where the distributions characterizing the actual measurement uncertainties are normal (Gaussian)). Measurement Uncertainty for a Level of Confidence of 95 %, $U=2xUc(y)$.

The BTL measurement uncertainty as below table:

A. Conducted Measurement:

Test Site	Method	Measurement Frequency Range	U, (dB)
DG-C02	CISPR	150 KHz ~ 30MHz	2.32

B. Radiated Measurement:

Test Site	Method	Measurement Frequency Range	Ant. H / V	U, (dB)
DG-CB03	CISPR	9kHz~30MHz	V	3.79
		9kHz~30MHz	H	3.57
		30MHz ~ 200MHz	V	3.82
		30MHz ~ 200MHz	H	3.60
		200MHz ~ 1,000MHz	V	3.86
		200MHz ~ 1,000MHz	H	3.94
		1GHz~18GHz	V	3.12
		1GHz~18GHz	H	3.68
		18GHz~40GHz	V	4.15
		18GHz~40GHz	H	4.14

Note: Unless specifically mentioned, the uncertainty of measurement has not been taken into account to declare the compliance or non-compliance to the specification.

3. GENERAL INFORMATION

3.1 GENERAL DESCRIPTION OF EUT

Equipment	WIFI+BT Audio Module	
Brand Name	TCL	
Model Name	TWM-A8516+MT6630T	
Series Model	N/A	
Mode Different	N/A	
Product Description	Operation Frequency	UNII-1: 5150-5250MHz UNII-2A: 5250-5350MHz UNII-2C: 5470-5725MHz UNII-3: 5725-5850MHz
	Modulation Type	OFDM
	Bit Rate of Transmitter	150 Mbps
Power Source	Supplied from PC USB port.	
Power Rating	DC 5V	
Output Power	Output Power (Max.) for UNII-1	802.11a: 15.27 dBm 802.11n (20M): 15.18 dBm 802.11n (40M): 14.10 dBm
	Output Power (Max.) for UNII-2A	802.11a: 16.62 dBm 802.11n (20M): 15.35 dBm 802.11n (40M): 14.72 dBm
	Output Power (Max.) for UNII-2C	802.11a: 14.95 dBm 802.11n (20M): 14.90 dBm 802.11n (40M): 14.72 dBm
	Output Power (Max.) for UNII-3	802.11a: 15.19 dBm 802.11n (20M): 14.92 dBm 802.11n (40M): 14.70 dBm

Note:

1. For a more detailed features description, please refer to the manufacturer's specifications or the User's Manual.
2. Channel List:

802.11a 802.11n 20MHz		802.11n 40MHz	
UNII-1		UNII-1	
Channel	Frequency (MHz)	Channel	Frequency (MHz)
36	5180	38	5190
40	5200	46	5230
44	5220		
48	5240		

802.11a 802.11n 20MHz		802.11n 40MHz	
UNII-2A		UNII-2A	
Channel	Frequency (MHz)	Channel	Frequency (MHz)
52	5260	54	5270
56	5280	62	5310
60	5300		
64	5320		

802.11a 802.11n 20MHz		802.11n 40MHz	
UNII-2C		UNII-2C	
Channel	Frequency (MHz)	Channel	Frequency (MHz)
100	5500	102	5510
104	5520	110	5550
108	5540	118	5590
112	5560	126	5630
116	5580	134	5670
132	5660		
136	5680		
140	5700		

802.11a 802.11n 20MHz		802.11n 40MHz	
UNII-3		UNII-3	
Channel	Frequency (MHz)	Channel	Frequency (MHz)
149	5745	151	5755
153	5765	159	5795
157	5785		
161	5805		
165	5825		

3. Antenna Specification:

Ant.	Manufacturer	Model Name	Antenna Type	Connector	Gain (dBi)	Note
1	TCL	N/A	PIFA	IPEX	6.39	N/A

Note:

(1) Antenna Gain=6.39dBi. So,the UNII-1,UNII-2A,UNII-2C

out power limit is $24-6.39+6=23.61$, the UNII-3 output power limit is $30-6.39+6=29.61$.

The UNII-1,UNII-2A,UNII-2C power density limit is $11-6.39+6=10.61$, the UNII-3 power density limit is $30-6.39+6=29.61$.

3.2 DESCRIPTION OF TEST MODES

To investigate the maximum EMI emission characteristics generates from EUT, the test system was pre-scanning tested base on the consideration of following EUT operation mode or test configuration mode which possible have effect on EMI emission level. Each of these EUT operation mode(s) or test configuration mode(s) mentioned above was evaluated respectively.

Pretest Mode	Description
Mode 1	TX A Mode / CH36, CH40, CH48 (UNII-1)
Mode 2	TX N20 Mode / CH36, CH40, CH48 (UNII-1)
Mode 3	TX N40 Mode / CH38, CH46 (UNII-1)
Mode 4	TX A Mode / CH52, CH60, CH64 (UNII-2A)
Mode 5	TX N20 Mode / CH52, CH60, CH64 (UNII-2A)
Mode 6	TX N40 Mode / CH54, CH62 (UNII-2A)
Mode 7	TX A Mode / CH100, CH116, CH140 (UNII-2C)
Mode 8	TX N20 Mode / CH100, CH116, CH140 (UNII-2C)
Mode 9	TX N40 Mode / CH102, CH110, CH134 (UNII-2C)
Mode 10	TX A Mode / CH149,CH157,CH165 (UNII-3)
Mode 11	TX N20 Mode / CH149,CH157,CH165 (UNII-3)
Mode 12	TX N40 Mode / CH151,CH159 (UNII-3)
Mode 13	TX Mode

The EUT system operated these modes were found to be the worst case during the pre-scanning test as following:

For Conducted Test	
Final Test Mode	Description
Mode 13	TX Mode

For Radiated Test	
Final Test Mode	Description
Mode 1	TX A Mode / CH36, CH40, CH48 (UNII-1)
Mode 2	TX N20 Mode / CH36, CH40, CH48 (UNII-1)
Mode 3	TX N40 Mode / CH38, CH46 (UNII-1)
Mode 4	TX A Mode / CH52, CH60, CH64 (UNII-2A)
Mode 5	TX N20 Mode / CH52, CH60, CH64 (UNII-2A)
Mode 6	TX N40 Mode / CH54, CH62 (UNII-2A)
Mode 7	TX A Mode / CH100, CH116, CH140 (UNII-2C)
Mode 8	TX N20 Mode / CH100, CH116, CH140 (UNII-2C)
Mode 9	TX N40 Mode / CH102, CH110, CH134 (UNII-2C)
Mode 10	TX A Mode / CH149,CH157,CH165 (UNII-3)
Mode 11	TX N20 Mode / CH149,CH157,CH165 (UNII-3)
Mode 12	TX N40 Mode / CH151,CH159 (UNII-3)

Note:

(1) For radiated below 1GHz test, the 802.11a mode is found to be the worst case and recorded.

3.3 TABLE OF PARAMETERS OF TEST SOFTWARE SETTING

During testing channel & power controlling software provided by the customer was used to control the operating channel as well as the output power level. The RF output power selection is for the setting of RF output power expected by the customer and is going to be fixed on the firmware of the final end product

UNII-1			
Test Software Version	SP META Tool		
Frequency (MHz)	5180	5200	5240
A Mode	16	16	16
Frequency (MHz)	5180	5200	5240
N20 Mode	16	16	16
Frequency (MHz)	5190	5230	
N40 Mode	14	15	

UNII-2A			
Test Software Version	SP META Tool		
Frequency (MHz)	5260	5300	5320
A Mode	16	16	16
Frequency (MHz)	5260	5300	5320
N20 Mode	17	17	17
Frequency (MHz)	5270	5310	
N40 Mode	16	15	

UNII-2C			
Test Software Version	SP META Tool		
Frequency (MHz)	5500	5580	5700
A Mode	15	15	15
Frequency (MHz)	5500	5580	5700
N20 Mode	15	15	15
Frequency (MHz)	5510	5550	5670
N40 Mode	13	14	15

UNII-3			
Test Software Version	SP META Tool		
Frequency (MHz)	5745	5785	5825
A Mode	16	16	16
Frequency (MHz)	5745	5785	5825
N20 Mode	15	15	15
Frequency (MHz)	5755	5795	
N40 Mode	14	15	

3.4 BLOCK DIAGRAM SHOWING THE CONFIGURATION OF SYSTEM TESTED

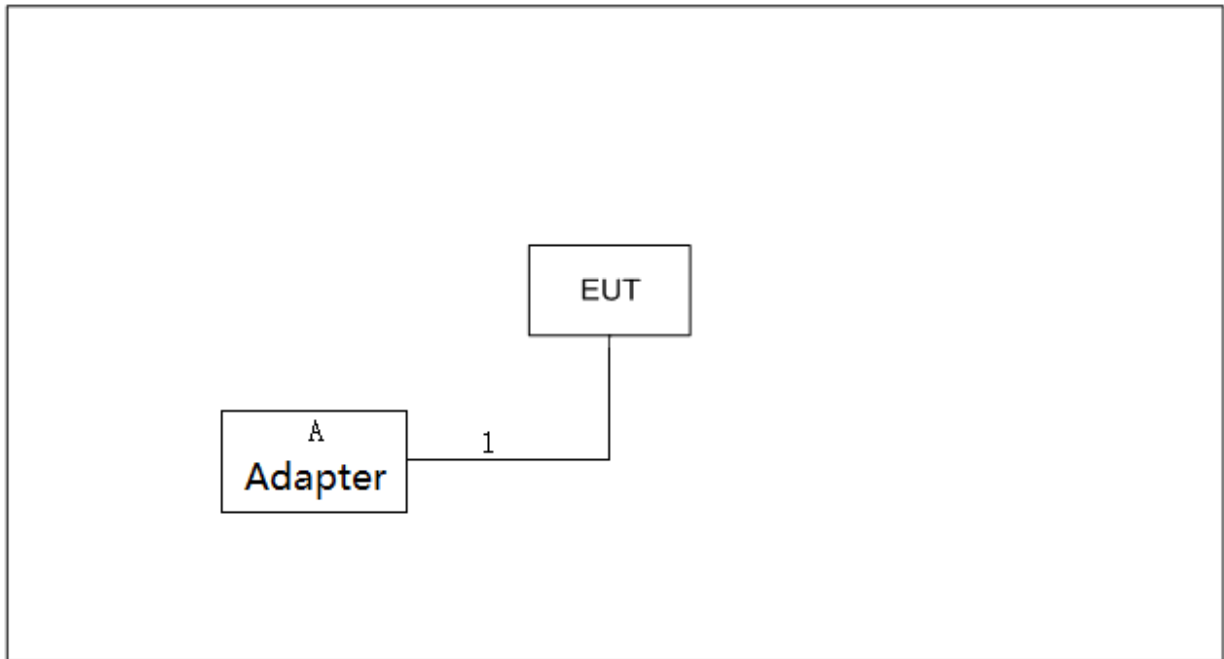

3.5 DESCRIPTION OF SUPPORT UNITS

The EUT has been tested as an independent unit together with other necessary accessories or support units. The following support units or accessories were used to form a representative test configuration during the tests.

Item	Equipment	Mfr/Brand	Model/Type No.	FCC ID	Series No.
-	-	-	-	-	-

Item	Shielded Type	Ferrite Core	Length	Note
1	NO	NO	0.8m	USB Cable

4. EMC EMISSION TEST

4.1 CONDUCTED EMISSION MEASUREMENT

4.1.1 POWER LINE CONDUCTED EMISSION (Frequency Range 150kHz-30MHz)

FREQUENCY (MHz)	Class A (dBuV)		Class B (dBuV)	
	Quasi-peak	Average	Quasi-peak	Average
0.15 -0.5	79.00	66.00	66 - 56 *	56 - 46 *
0.50 -5.0	73.00	60.00	56.00	46.00
5.0 -30.0	73.00	60.00	60.00	50.00

Note:

- (1) The tighter limit applies at the band edges.
- (2) The limit of " * " marked band means the limitation decreases linearly with the logarithm of the frequency in the range.

4.1.2 TEST PROCEDURE

- a. The EUT was placed 0.8 meters from the horizontal ground plane with EUT being connected to the power mains through a line impedance stabilization network (LISN). All other support equipments powered from additional LISN(s). The LISN provide 50 Ohm/ 50uH of coupling impedance for the measuring instrument.
- b. Interconnecting cables that hang closer than 40 cm to the ground plane shall be folded back and forth in the center forming a bundle 30 to 40 cm long.
- c. I/O cables that are not connected to a peripheral shall be bundled in the center. The end of the cable may be terminated, if required, using the correct terminating impedance. The overall length shall not exceed 1 m.
- d. LISN at least 80 cm from nearest part of EUT chassis.
- e. For the actual test configuration, please refer to the related Item –EUT Test Photos.

4.1.3 DEVIATION FROM TEST STANDARD

No deviation

4.1.4 TEST SETUP

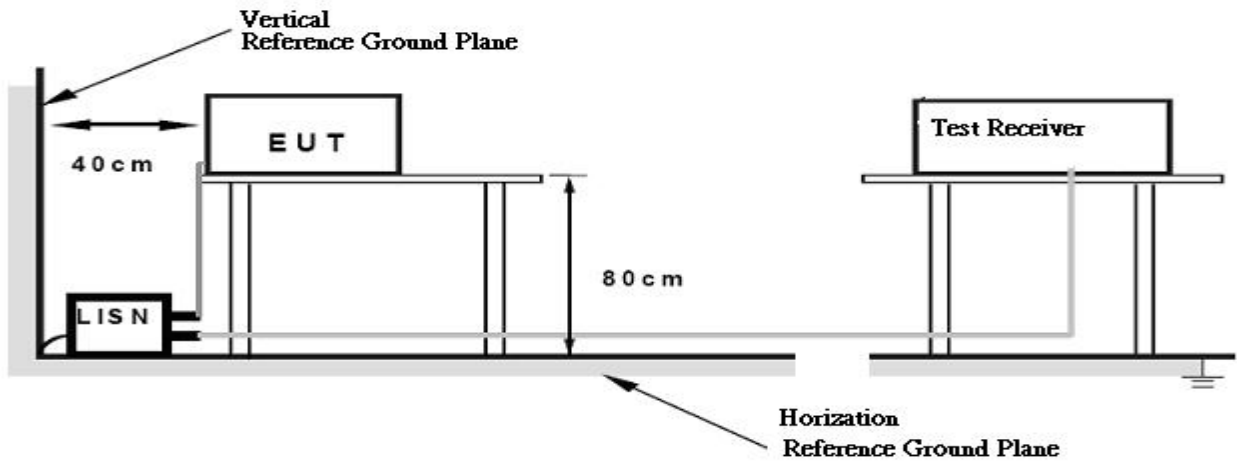

4.1.5 EUT OPERATING CONDITIONS

The EUT was configured for testing in a typical fashion (as a customer would normally use it). The EUT has been programmed to continuously transmit during test. This operating condition was tested and used to collect the included data.

The EUT was programmed to be in continuously transmitting/TX Mode mode.

4.1.6 EUT TEST CONDITIONS

Temperature: 25°C Relative Humidity: 53% Test Voltage: AC 120V/60Hz

4.1.7 TEST RESULTS

Please refer to the Appendix A.

Remark:

- (1) All readings are QP Mode value unless otherwise stated AVG in column of『Note』. If the QP Mode Measured value compliance with the QP Limits and lower than AVG Limits, the EUT shall be deemed to meet both QP & AVG Limits and then only QP Mode was measured, but AVG Mode didn't perform. In this case, a “ * ” marked in AVG Mode column of Interference Voltage Measured.
- (2) Measuring frequency range from 150kHz to 30MHz.

4.2 RADIATED EMISSION MEASUREMENT

4.2.1 RADIATED EMISSION LIMITS

In case the emission fall within the restricted band specified on 15.205(a), then the 15.209(a) limit in the table below has to be followed.

Frequencies (MHz)	Field Strength (microrvolts/meter)	Measurement Distance (meters)
0.009~0.490	2400/F(kHz)	300
0.490~1.705	24000/F(kHz)	30
1.705~30.0	30	30
30~88	100	3
88~216	150	3
216~960	200	3
Above 960	500	3

Frequencies (MHz)	EIRP Limit (dBm)	Equivalent Field Strength at 3m (dBμV/m)
5150-5250	-27	68.3
5250-5350	-27	68.3
5470-5725	-27	68.3
5725-5850	-27(Note 2)	68.3
	10(Note 2)	105.3
	15.6(Note 2)	110.9
	27(Note 2)	122.3

Note:

1. The following formula is used to convert the equipment isotropic radiated power (eirp) to

field strength: $E = \frac{1000000\sqrt{30P}}{3} \mu\text{V/m}$, where P is the eirp (Watts)

2. According to FCC 16-24, All emissions shall be limited to a level of -27 dBm/MHz at 75 MHz or more above or below the band edge increasing linearly to 10 dBm/MHz at 25 MHz above or below the band edge, and from 25MHz above or below the band edge increasing linearly to a level of 15.6 dBm/MHz at 5 MHz above or below the band edge, and from 5 MHz above or below the band edge increasing linearly to a level of 27dBm/MHz at the band edge.

4.2.2 TEST PROCEDURE

- a. The measuring distance of 3 m shall be used for measurements. The EUT was placed on the top of a rotating table 0.8 meter above the ground at a 3 meter semi-anechoic chamber. The table was rotated 360 degrees to determine the position of the highest radiation.(below 1GHz)
- b. The measuring distance of 3 m shall be used for measurements. The EUT was placed on the top of a rotating table 1.5 meter above the ground at a 3 meter semi-anechoic chamber. The table was rotated 360 degrees to determine the position of the highest radiation.(above 1GHz)
- c. The height of the equipment or of the substitution antenna shall be 0.8m or 1.5m; the height of the test antenna shall vary between 1 m to 4 m. Both horizontal and vertical polarizations of the antenna are set to make the measurement.
- d. For each suspected emission, the EUT was arranged to its worst case and then the antenna was tuned to heights find the maximum reading (used Bore sight function).
- e. The receiver system was set to peak and average detect function and specified bandwidth with maximum hold mode when the test frequency is above 1GHz.
- f. The initial step in collecting radiated emission data is a receiver peak detector mode pre-scanning the measurement frequency range. Significant peaks are then marked and then Quasi Peak detector mode re-measured.
- g. All readings are Peak unless otherwise stated QP in column of Note. Peak denotes that the Peak reading compliance with the QP Limits and then QP Mode measurement didn't perform. (below 1GHz)
- h. All readings are Peak Mode value unless otherwise stated AVG in column of Note. If the Peak Mode Measured value compliance with the Peak Limits and lower than AVG Limits, the EUT shall be deemed to meet both Peak & AVG Limits and then only Peak Mode was measured, but AVG Mode didn't perform. (above 1GHz)
- i. For the actual test configuration, please refer to the related Item –EUT Test Photos.

4.2.3 DEVIATION FROM TEST STANDARD

No deviation

4.2.4 TEST SETUP

(A)Radiated Emission Test Set-Up Frequency Below 1GHz

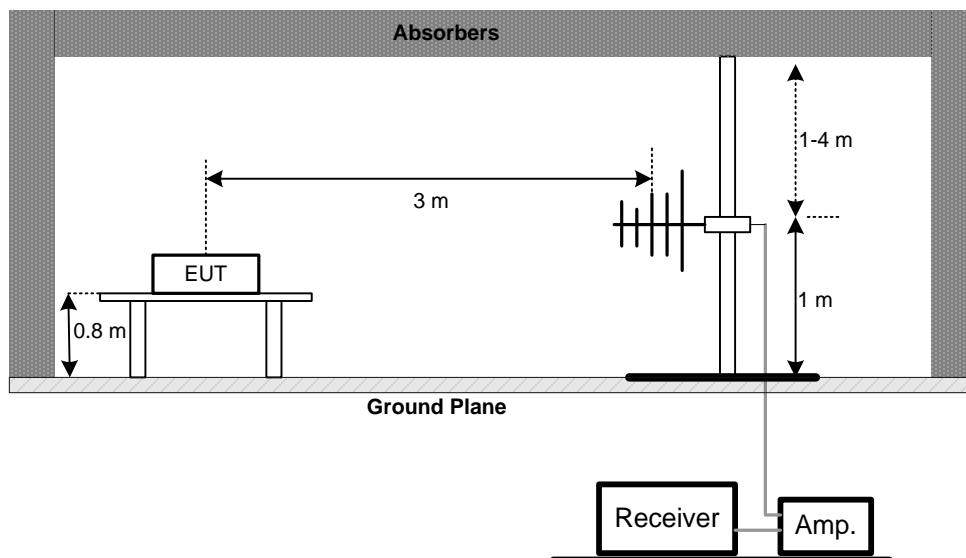

(B) Radiated Emission Test Set-Up Frequency Above 1 GHz

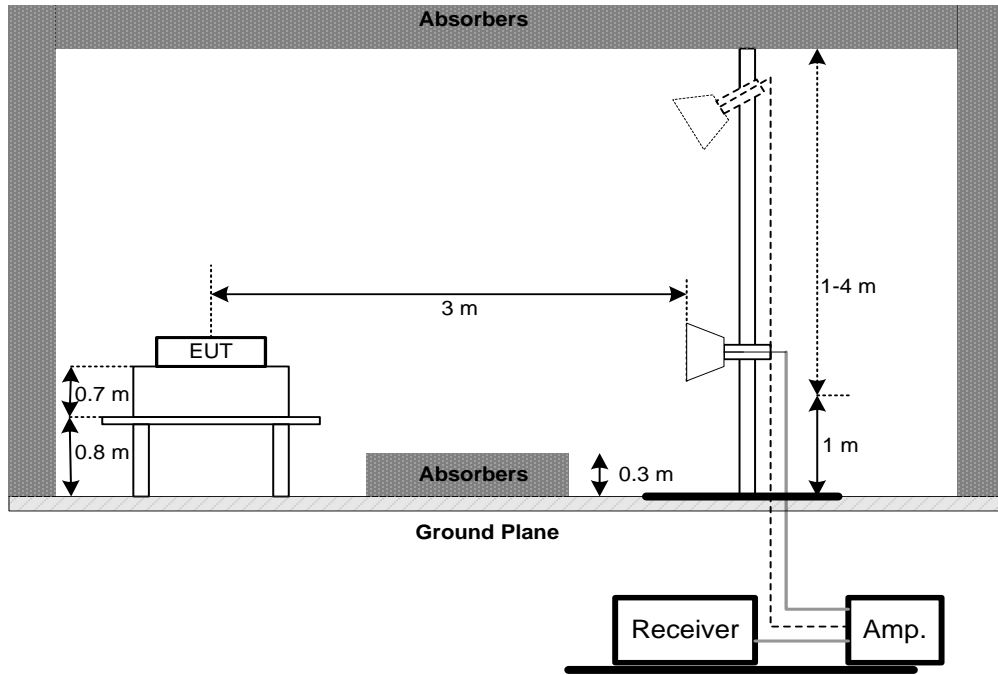

(C) Radiated emissions below 30MHz

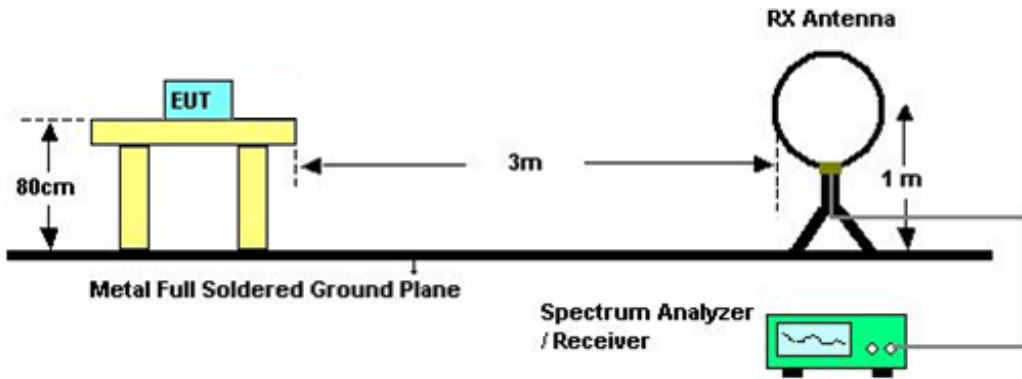

4.2.5 EUT OPERATING CONDITIONS

The EUT tested system was configured as the statements of 4.1.5 unless otherwise a special operating condition is specified in the follows during the testing.

4.2.6 EUT TEST CONDITIONS

Temperature: 25°C Relative Humidity: 60% Test Voltage: AC 120V/60Hz

4.2.7 TEST RESULTS (9K TO 30MHz)

Please refer to the Appendix B

Remark:

- (1) The amplitude of spurious emissions which are attenuated by more than 20 dB below the permissible value has no need to be reported.
- (2) Distance extrapolation factor = $40 \log(\text{specific distance} / \text{test distance})$ (dB);
- (3) Limit line = specific limits (dBuV) + distance extrapolation factor.

4.2.8 TEST RESULTS (BETWEEN 30 TO 1000 MHz)

Please refer to the Appendix C.

4.2.9 TEST RESULTS (ABOVE 1000 MHz)

Please refer to the Appendix D.

Remark:

- (1) No limit: This is fundamental signal, the judgment is not applicable.
For fundamental signal judgment was referred to Peak output test.

5. 26dB SPECTRUM BANDWIDTH

5.1 APPLIED PROCEDURES / LIMIT

FCC Part15, Subpart E			
Test Item	Limit	Frequency Range (MHz)	Result
Bandwidth	26 dB Bandwidth	5150-5250	PASS
	26 dB Bandwidth	5250-5350	PASS
	26 dB Bandwidth	5470-5725	PASS
	Minimum 500kHz 6dB Bandwidth	5725-5850	PASS

5.1.1 TEST PROCEDURE

a. The EUT was directly connected to the spectrum analyzer and antenna output port as show in the block diagram below,

b.

Spectrum Parameters	Setting
Attenuation	Auto
Span Frequency	> 26dB Bandwidth
RBW	300 kHz(Bandwidth 20MHz) 1MHz(Bandwidth 40MHz and 80MHz)
VBW	1MHz(Bandwidth 20MHz) 3MHz(Bandwidth 40MHz and 80MHz)
Detector	Peak
Trace	Max Hold
Sweep Time	Auto

c. Measured the spectrum width with power higher than 26dB below carrier

5.1.2 DEVIATION FROM STANDARD

No deviation.

5.1.3 TEST SETUP



5.1.4 EUT OPERATION CONDITIONS

The EUT tested system was configured as the statements of 4.1.5 unless otherwise a special operating condition is specified in the follows during the testing.

5.1.5 EUT TEST CONDITIONS

Temperature: 25°C Relative Humidity: 60% Test Voltage: DC 5V

5.1.6 TEST RESULTS

Please refer to the Appendix E.

6. MAXIMUM CONDUCTED OUTPUT POWER

6.1 APPLIED PROCEDURES / LIMIT

FCC Part15, Subpart E			
Test Item	Limit	Frequency Range (MHz)	Result
Conducted Output Power	Fixed:1 Watt (30dBm) Mobile and portable: 250mW (24dBm)	5150-5250	PASS
	250mW (24dBm)	5250-5350	PASS
	250mW (24dBm)	5470-5725	PASS
	1 Watt (30dBm)	5725-5850	PASS

Note: The maximum e.i.r.p at any elevation angle above 30 degrees as measured from the horizon must not exceed 125mW(21dBm)

6.1.1 TEST PROCEDURE

- a. The EUT was directly connected to the spectrum analyzer and antenna output port as show in the block diagram below,
- b.

Spectrum Parameter	Setting
Attenuation	Auto
Span Frequency	Encompass the entire emissions bandwidth (EBW) of the signal
RBW	= 1MHz.
VBW	≥ 3MHz.
Detector	RMS
Trace	Max Hold
Sweep Time	auto

- c. Test was performed in accordance with method of KDB 789033 D02.

6.1.2 DEVIATION FROM STANDARD

No deviation.

6.1.3 TEST SETUP



6.1.4 EUT OPERATION CONDITIONS

The EUT tested system was configured as the statements of 4.1.5 unless otherwise a special operating condition is specified in the follows during the testing.

6.1.5 EUT TEST CONDITIONS

Temperature: 25°C Relative Humidity: 60% Test Voltage: DC 5V

6.1.6 TEST RESULTS

Please refer to the Appendix F.

7. POWER SPECTRAL DENSITY TEST

7.1 APPLIED PROCEDURES / LIMIT

FCC Part15, Subpart E			
Test Item	Limit	Frequency Range (MHz)	Result
Power Spectral Density	Other then Mobile and portable:17dBm/MHz Mobile and portable:11dBm/MHz	5150-5250	PASS
	11dBm/MHz	5250-5350	PASS
	11dBm/MHz	5470-5725	PASS
	30dBm/500kHz	5725-5850	PASS

7.1.1 TEST PROCEDURE

a. The EUT was directly connected to the spectrum analyzer and antenna output port as show in the block diagram below,

b.

Spectrum Parameter	Setting
Attenuation	Auto
Span Frequency	Encompass the entire emissions bandwidth (EBW) of the signal
RBW	= 1MHz.
VBW	≥ 3MHz.
Detector	RMS
Trace average	100 trace
Sweep Time	Auto

Note:

- For UNII-3, according to KDB publication 789033 D02 General UNII Test Procedures New Rules v01r02, section II.F.5., it is acceptable to set RBW at 1MHz and VBW at 3MHz if the spectrum analyzer does not have 500kHz RBW.
- The value measured with RBW=1MHz is to be added with $10\log(500\text{kHz}/1\text{MHz})$ which is -3dB. For example, if the measured value is +10dBm using RBW=1MHz (that is +10dBm/MHz), then the converted value will be +7dBm/500kHz.

7.1.2 DEVIATION FROM STANDARD

No deviation.

7.1.3 TEST SETUP



7.1.4 EUT OPERATION CONDITIONS

The EUT tested system was configured as the statements of 4.1.5 unless otherwise a special operating condition is specified in the follows during the testing.

7.1.5 EUT TEST CONDITIONS

Temperature: 25°C Relative Humidity: 60% Test Voltage: DC 5V

7.1.6 TEST RESULTS

Please refer to the Appendix H.

8. FREQUENCY STABILITY MEASUREMENT

8.1 APPLIED PROCEDURES / LIMIT

FCC Part15, Subpart E			
Test Item	Limit	Frequency Range (MHz)	Result
Frequency Stability	Specified in the user's manual	5150-5250	PASS
		5250-5350	PASS
		5470-5725	PASS
		5725-5850	PASS

8.1.1 TEST PROCEDURE

a. The EUT was directly connected to the spectrum analyzer and antenna output port as show in the block diagram below,

b.

Spectrum Parameter	Setting
Attenuation	Auto
Span Frequency	Entire absence of modulation emissions bandwidth
RBW	10 kHz
VBW	10 kHz
Sweep Time	Auto

c. The test extreme voltage is to change the primary supply voltage from 85 to 115 percent of the nominal value.

d. User manual temperature is -10°C~60°C.

8.1.2 DEVIATION FROM STANDARD

No deviation.

8.1.3 TEST SETUP

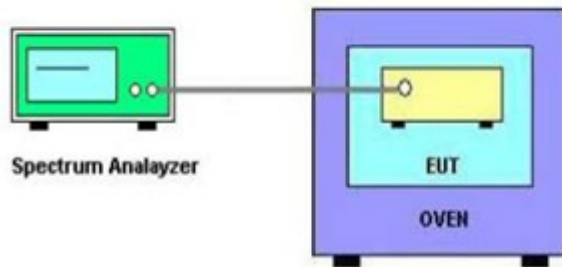

8.1.4 EUT OPERATION CONDITIONS

The EUT tested system was configured as the statements of 4.1.5 unless otherwise a special operating condition is specified in the follows during the testing.

8.1.5 EUT TEST CONDITIONS

Temperature: 25°C Relative Humidity: 55% Test Voltage: DC 5V

8.1.6 TEST RESULTS

Please refer to the Appendix I.

9. MEASUREMENT INSTRUMENTS LIST

Conducted Emission Measurement					
Item	Kind of Equipment	Manufacturer	Type No.	Serial No.	Calibrated until
1	EMI Test Receiver	R&S	ESCI	100382	Mar. 11, 2019
2	LISN	EMCO	3816/2	52765	Mar. 11, 2019
3	50Ω Terminator	SHX	TF2-3G-A	8122901	Mar. 11, 2019
4	TWO-LINE V-NETWORK	R&S	ENV216	101447	Mar. 11, 2019
5	Measurement Software	Farad	EZ-EMC Ver.NB-03A1-01	N/A	N/A
6	Cable	N/A	RG223	12m	Oct. 19, 2018

Radiated Emission Measurement - Below 1GHz					
Item	Kind of Equipment	Manufacturer	Type No.	Serial No.	Calibrated until
1	Antenna	Schwarbeck	VULB9160	9160-3232	Mar. 11, 2019
2	Amplifier	HP	8447D	2944A09673	Oct. 19, 2018
3	Receiver	Agilent	N9038A	MY52130039	Aug. 20, 2018
4	Cable	emci	LMR-400(30MHz-1 GHz)(8m+5m)	N/A	Jun. 26, 2018
5	Controller	CT	SC100	N/A	N/A
6	Controller	MF	MF-7802	MF780208416	N/A
7	Measurement Software	Farad	EZ-EMC Ver.NB-03A1-01	N/A	N/A
8	Antenna	EM	EM-6876-1	230	Feb. 07, 2019

Radiated Emission Measurement - Above 1GHz					
Item	Kind of Equipment	Manufacturer	Type No.	Serial No.	Calibrated until
1	Double Ridged Guide Antenna	ETS	3115	75789	Mar. 11, 2019
2	Broad-Band Horn Antenna	Schwarzbeck	BBHA 9170	9170319	Jun. 08, 2018
3	Amplifier	Agilent	8449B	3008A02274	Mar. 11, 2019
4	Microwave Preamplifier With Adaptor	EMC INSTRUMENT	EMC2654045	980039 & HA01	Mar. 11, 2019
5	Receiver	Agilent	N9038A	MY52130039	Aug. 20, 2018
6	Controller	CT	SC100	N/A	N/A
7	Controller	MF	MF-7802	MF780208416	N/A
8	Cable	emci	EMC104-SM-SM-1 2000(12m)	N/A	Jun. 26, 2018
9	Measurement Software	Farad	EZ-EMC Ver.NB-03A1-01	N/A	N/A

Spectrum Bandwidth Measurement					
Item	Kind of Equipment	Manufacturer	Type No.	Serial No.	Calibrated until
1	Spectrum Analyzer	R&S	FSP40	100185	Aug. 20, 2018

Maximum Conducted Output Power Measurement					
Item	Kind of Equipment	Manufacturer	Type No.	Serial No.	Calibrated until
1	Spectrum Analyzer	R&S	FSP40	100185	Aug. 20, 2018

Power Spectral Density Measurement					
Item	Kind of Equipment	Manufacturer	Type No.	Serial No.	Calibrated until
1	Spectrum Analyzer	R&S	FSP40	100185	Aug. 20, 2018

Frequency Stability Measurement					
Item	Kind of Equipment	Manufacturer	Type No.	Serial No.	Calibrated until
1	Spectrum Analyzer	R&S	FSP40	100185	Aug. 20, 2018
2	Precision Oven Tester	Bell	BTH-50C	20170306001	Mar. 11, 2019

Remark: "N/A" denotes no model name, serial no. or calibration specified.
 All calibration period of equipment list is one year.

10. EUT TEST PHOTOS

Conducted Measurement Photos

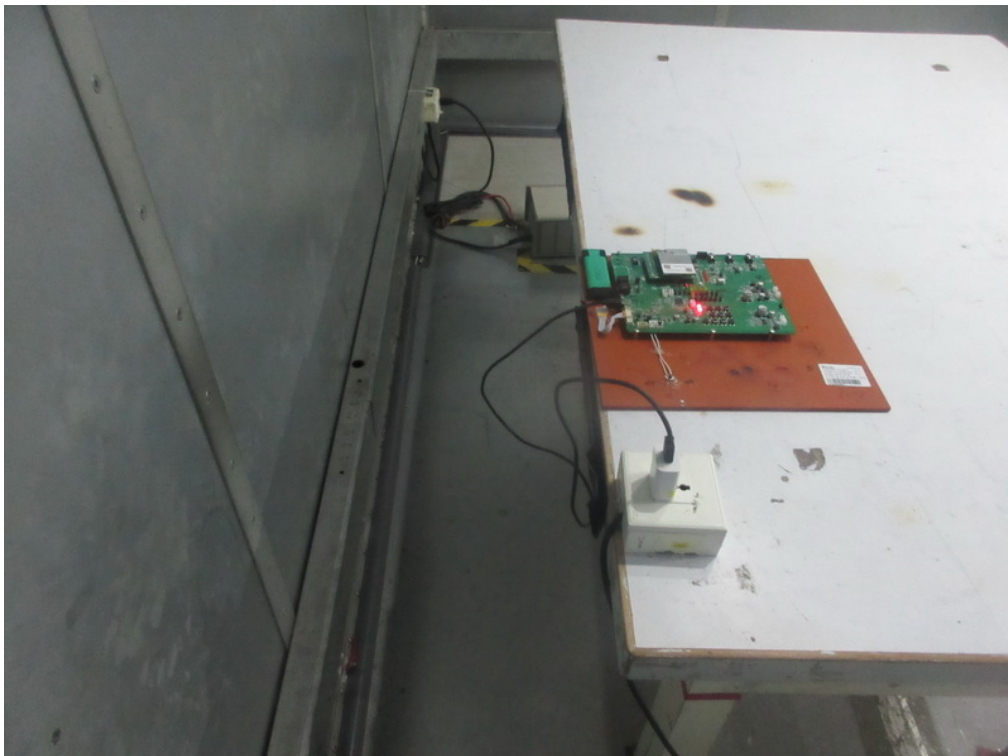

Radiated Measurement Photos

9kHz to 30MHz



Radiated Measurement Photos

30MHz to 1000MHz

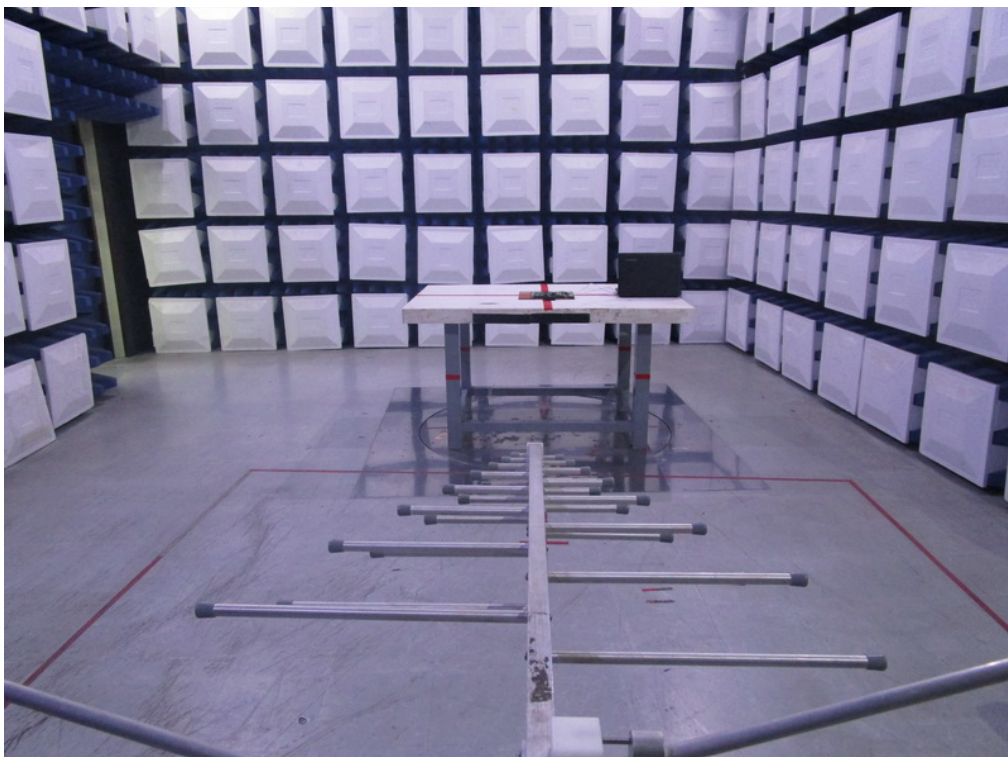

Radiated Measurement Photos

Above 1000MHz

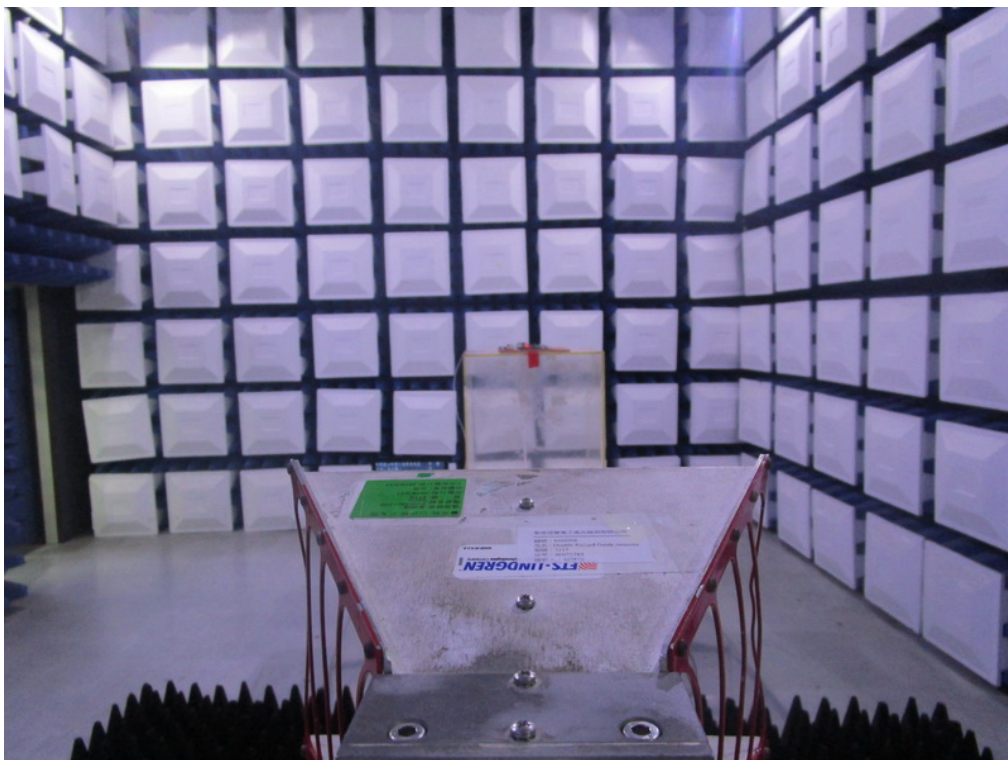

APPENDIX A - CONDUCTED EMISSION

Test Mode: TX MODE

Line

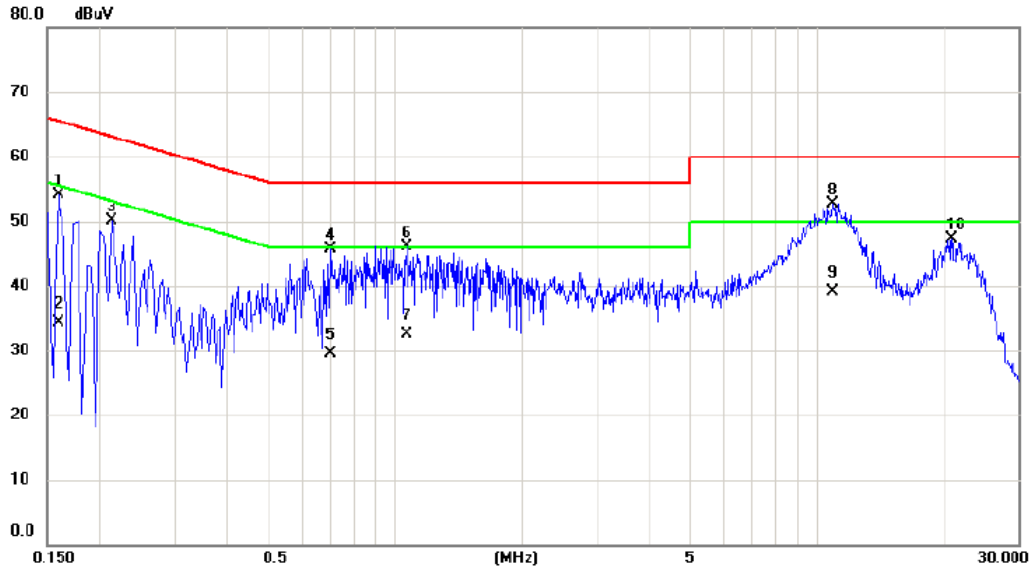

No.	Mk.	Freq. MHz	Reading Level dBuV	Correct Factor dB	Measure- ment dBuV	Limit dBuV	Margin dB	Detector	Comment
1		0.1590	44.32	9.82	54.14	65.52	-11.38	peak	
2		0.1590	24.50	9.82	34.32	55.52	-21.20	AVG	
3		0.2130	40.21	9.82	50.03	63.09	-13.06	peak	
4		0.7035	35.76	9.87	45.63	56.00	-10.37	peak	
5		0.7035	19.60	9.87	29.47	46.00	-16.53	AVG	
6		1.0635	36.16	9.92	46.08	56.00	-9.92	peak	
7		1.0635	22.60	9.92	32.52	46.00	-13.48	AVG	
8	*	10.8600	42.22	10.53	52.75	60.00	-7.25	peak	
9		10.8600	28.50	10.53	39.03	50.00	-10.97	AVG	
10		20.9130	36.12	11.17	47.29	60.00	-12.71	peak	

Note : The test result has included the cable loss.

Test Mode: TX MODE

Neutral

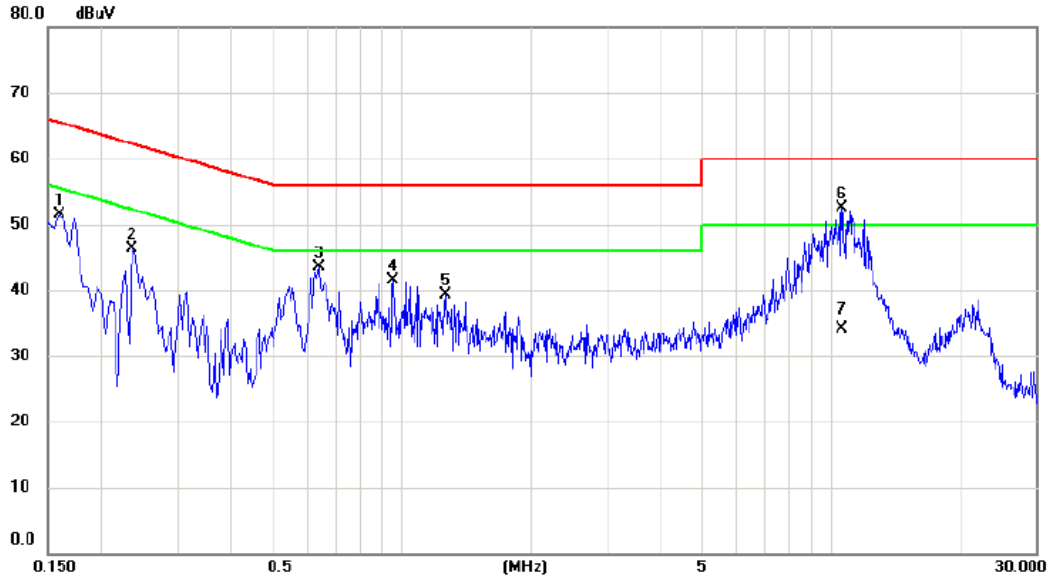

No.	Mk.	Freq. MHz	Reading Level dBuV	Correct Factor dB	Measure- ment dBuV	Limit dBuV	Margin dB	Detector	Comment
1		0.1590	41.54	9.91	51.45	65.52	-14.07	peak	
2		0.2355	36.34	9.91	46.25	62.25	-16.00	peak	
3		0.6405	33.51	10.01	43.52	56.00	-12.48	peak	
4		0.9510	31.41	10.11	41.52	56.00	-14.48	peak	
5		1.2660	29.10	10.14	39.24	56.00	-16.76	peak	
6	*	10.6080	41.77	10.78	52.55	60.00	-7.45	peak	
7		10.6080	23.30	10.78	34.08	50.00	-15.92	AVG	

Note : The test result has included the cable loss.

APPENDIX B - RADIATED EMISSION (9KHZ TO 30MHZ)

Test Mode: TX MODE

Ant 0°

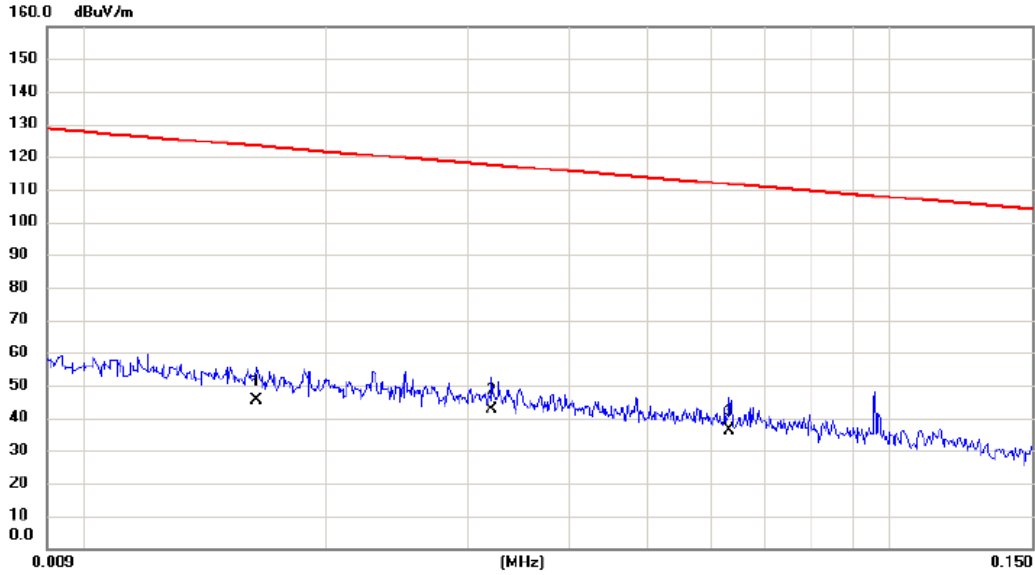

No.	Mk.	Freq. MHz	Reading Level dBuV/m	Correct Factor dB	Measure- ment dBuV/m	Limit dBuV/m	Margin dB	Detector	Comment
1		0.0164	25.47	20.09	45.56	123.31	-77.75	AVG	
2	*	0.0321	23.30	19.26	42.56	117.47	-74.91	AVG	
3		0.0632	17.84	18.47	36.31	111.59	-75.28	AVG	

Test Mode: TX MODE

Ant 0°

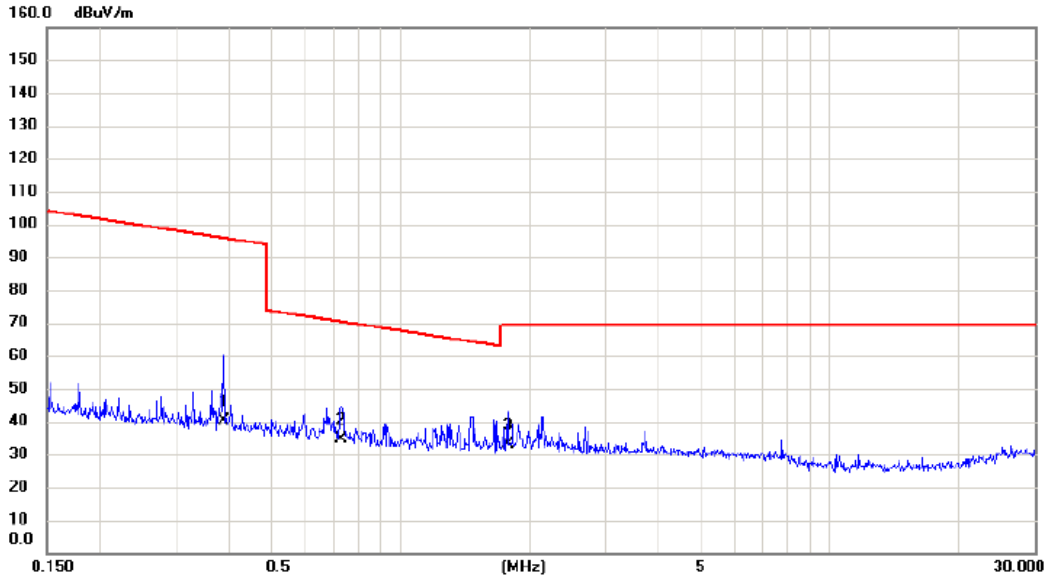

No.	Mk.	Freq. MHz	Reading Level dBuV/m	Correct Factor dB	Measure- ment dBuV/m	Limit dBuV/m	Margin dB	Detector	Comment
1		0.3871	23.67	16.55	40.22	95.85	-55.63	AVG	
2	*	0.7273	18.36	16.21	34.57	70.37	-35.80	QP	
3		1.7810	17.42	15.60	33.02	69.54	-36.52	QP	

Test Mode: TX MODE

Ant 90°

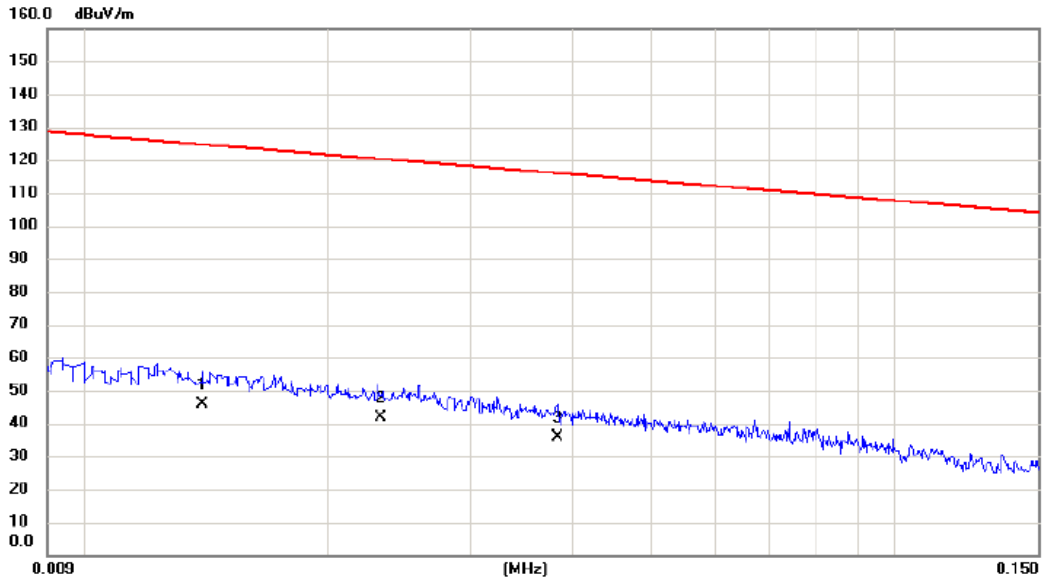

No.	Mk.	Freq. MHz	Reading Level dBuV/m	Correct Factor dB	Measure- ment dBuV/m	Limit dBuV/m	Margin dB	Detector	Comment
1		0.0140	25.30	20.40	45.70	124.68	-78.98	AVG	
2	*	0.0232	22.11	19.52	41.63	120.30	-78.67	AVG	
3		0.0383	16.61	19.07	35.68	115.94	-80.26	AVG	

Test Mode: TX MODE

Ant 90°

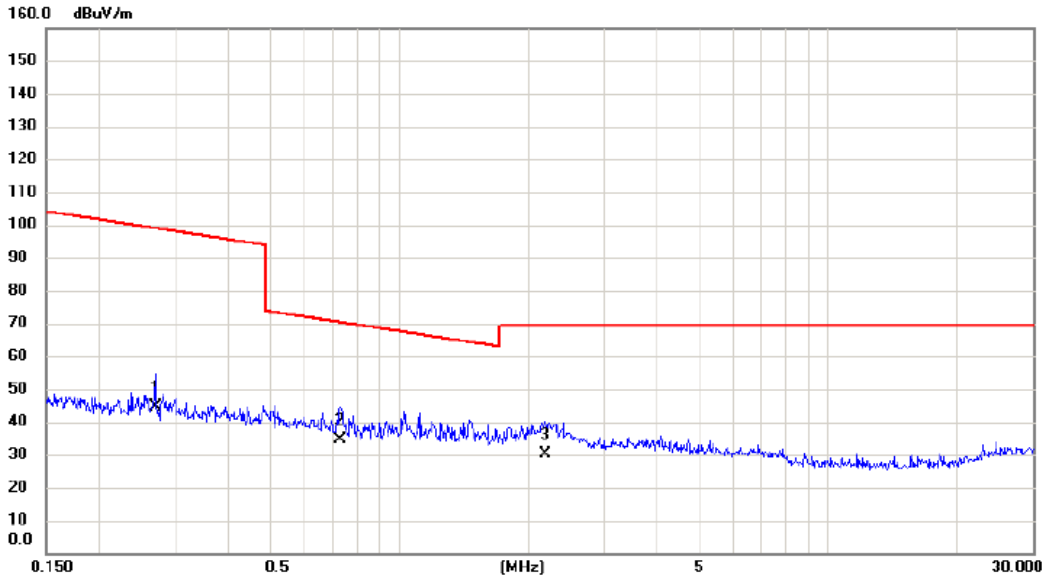

No.	Mk.	Freq. MHz	Reading Level dBuV/m	Correct Factor dB	Measure- ment dBuV/m	Limit dBuV/m	Margin dB	Detector	Comment
1		0.2701	27.99	16.64	44.63	98.97	-54.34	AVG	
2	*	0.7273	18.59	16.21	34.80	70.37	-35.57	QP	
3		2.1898	14.64	15.45	30.09	69.54	-39.45	QP	

APPENDIX C - RADIATED EMISSION (30MHZ TO 1000MHZ)

Test Mode: UNII-1/TX A Mode 5180MHz

Vertical

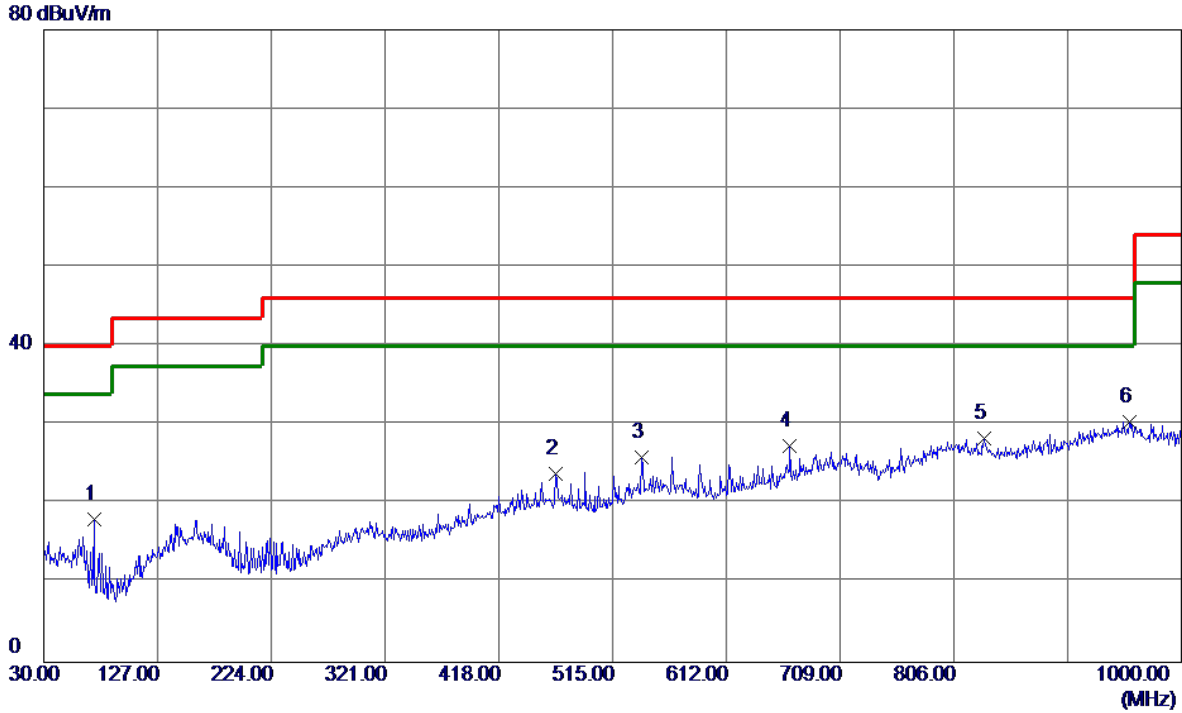

No.	Freq. MHz	Reading Level dBuV/m	Correct Factor dB	Measure ment dBuV/m	Limit dBuV/m	Margin dB	Detector	Comment
1	72.6800	36.49	-18.48	18.01	40.00	-21.99	Peak	
2	466.5000	32.39	-8.48	23.91	46.00	-22.09	Peak	
3	540.2199	32.71	-6.75	25.96	46.00	-20.04	Peak	
4	666.3200	32.37	-5.05	27.32	46.00	-18.68	Peak	
5	832.1900	30.36	-2.09	28.27	46.00	-17.73	Peak	
6 *	955.3800	29.67	0.80	30.47	46.00	-15.53	Peak	

Test Mode: UNII-1/TX A Mode 5180MHz

Horizontal

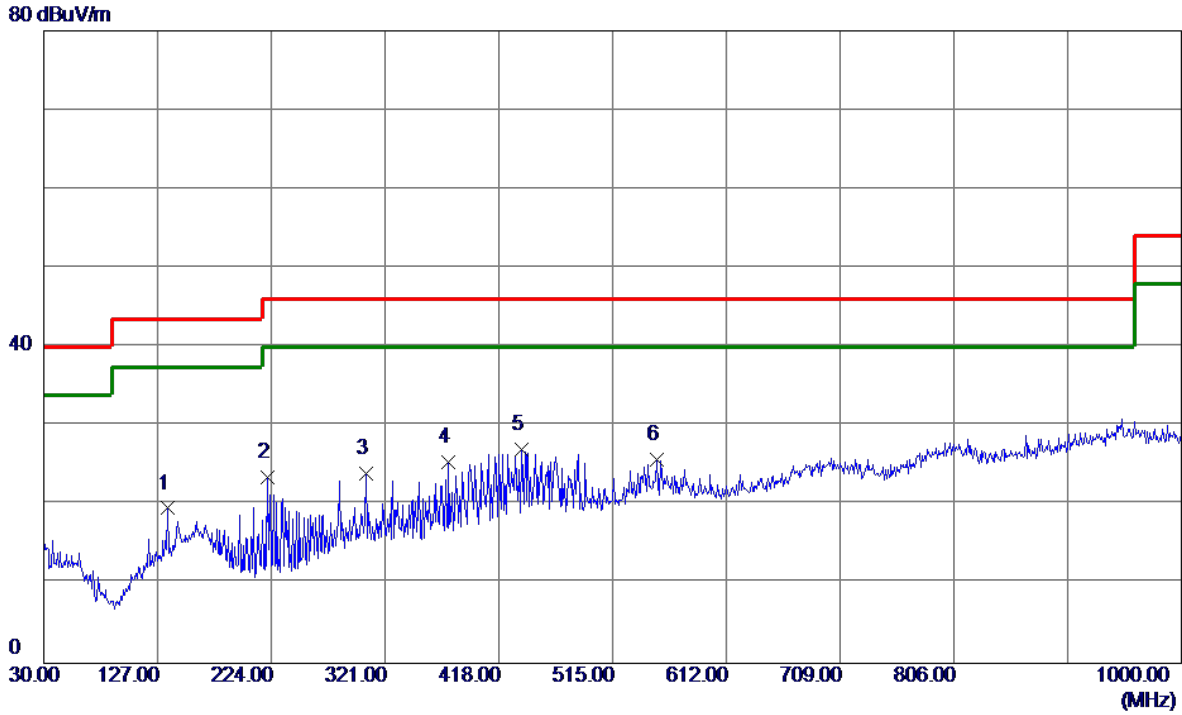

No.	Freq. MHz	Reading Level dBuV/m	Correct Factor dB	Measure ment dBuV/m	Limit dBuV/m	Margin dB	Detector	Comment
1	135.7300	32.91	-13.31	19.60	43.50	-23.90	Peak	
2	221.0900	39.16	-15.59	23.57	46.00	-22.43	Peak	
3	304.5100	35.12	-11.18	23.94	46.00	-22.06	Peak	
4	375.3200	36.40	-10.94	25.46	46.00	-20.54	Peak	
5 *	437.4000	35.67	-8.61	27.06	46.00	-18.94	Peak	
6	552.8300	31.91	-6.20	25.71	46.00	-20.29	Peak	

Test Mode: UNII-1/TX A Mode 5200MHz

Vertical

80 dBuV/m

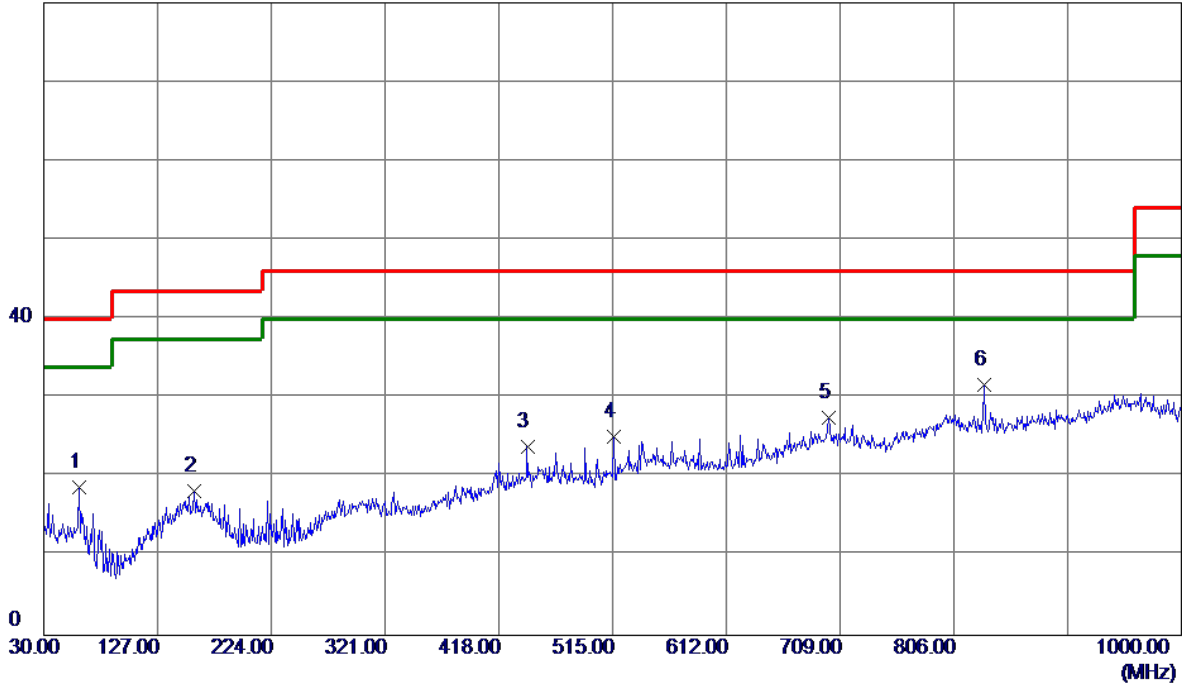

No.	Freq. MHz	Reading Level dBuV/m	Correct Factor dB	Measure ment dBuV/m	Limit dBuV/m	Margin dB	Detector	Comment
1	60.0700	34.88	-16.19	18.69	40.00	-21.31	Peak	
2	158.0399	29.66	-11.47	18.19	43.50	-25.31	Peak	
3	442.2500	32.26	-8.42	23.84	46.00	-22.16	Peak	
4	515.9699	33.37	-8.25	25.12	46.00	-20.88	Peak	
5	699.3000	31.02	-3.44	27.58	46.00	-18.42	Peak	
6 *	832.1900	33.75	-2.09	31.66	46.00	-14.34	Peak	

Test Mode: UNII-1/TX A Mode 5200MHz

Horizontal

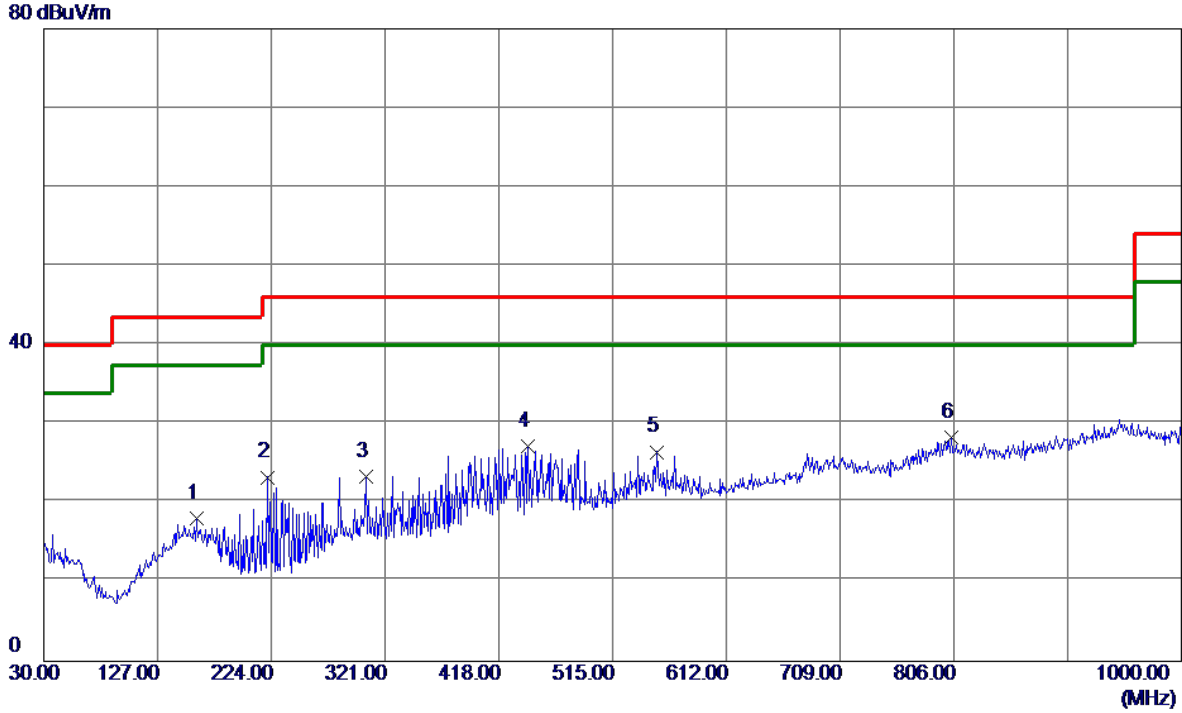

No.	Freq. MHz	Reading Level dBuV/m	Correct Factor dB	Measure ment dBuV/m	Limit dBuV/m	Margin dB	Detector	Comment
1	159.9800	29.39	-11.30	18.09	43.50	-25.41	Peak	
2	221.0900	38.87	-15.59	23.28	46.00	-22.72	Peak	
3	304.5100	34.59	-11.18	23.41	46.00	-22.59	Peak	
4	443.2200	35.54	-8.38	27.16	46.00	-18.84	Peak	
5	552.8300	32.68	-6.20	26.48	46.00	-19.52	Peak	
6 *	804.0600	29.95	-1.68	28.27	46.00	-17.73	Peak	

Test Mode: UNII-1/TX A Mode 5240MHz

Vertical

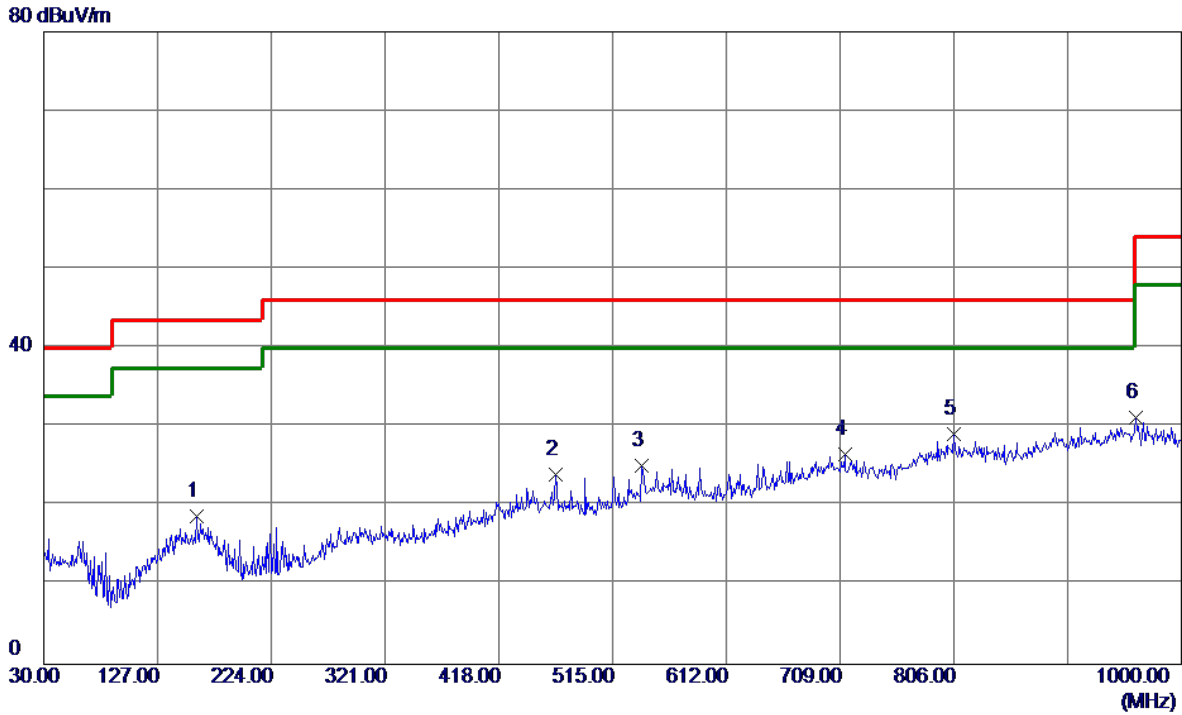

No.	Freq. MHz	Reading Level dBuV/m	Correct Factor dB	Measure ment dBuV/m	Limit dBuV/m	Margin dB	Detector	Comment
1	159.9800	30.04	-11.30	18.74	43.50	-24.76	Peak	
2	466.5000	32.42	-8.48	23.94	46.00	-22.06	Peak	
3	540.2199	31.88	-6.75	25.13	46.00	-20.87	Peak	
4	712.8800	30.32	-3.73	26.59	46.00	-19.41	Peak	
5 *	806.0000	30.85	-1.71	29.14	46.00	-16.86	Peak	
6	961.2000	30.58	0.67	31.25	54.00	-22.75	Peak	

Test Mode: UNII-1/TX A Mode 5240MHz

Horizontal

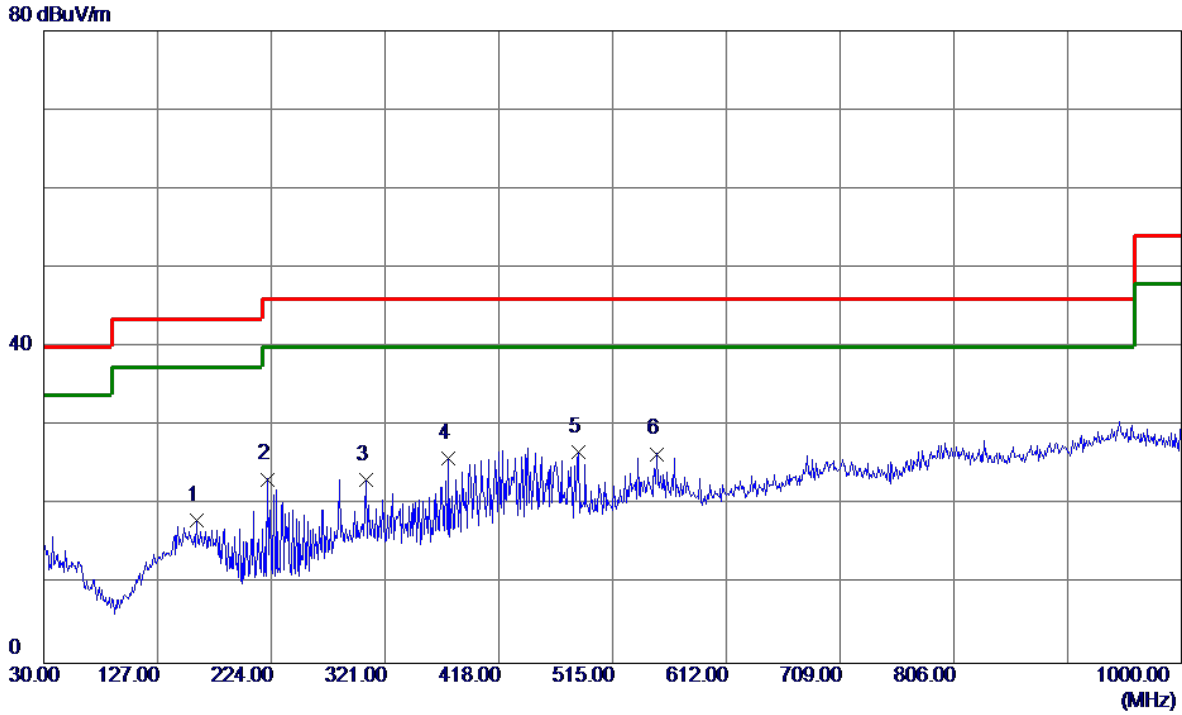

No.	Freq. MHz	Reading Level dBuV/m	Correct Factor dB	Measure ment dBuV/m	Limit dBuV/m	Margin dB	Detector	Comment
1	159.9800	29.39	-11.30	18.09	43.50	-25.41	Peak	
2	221.0900	38.87	-15.59	23.28	46.00	-22.72	Peak	
3	304.5100	34.44	-11.18	23.26	46.00	-22.74	Peak	
4	375.3200	36.80	-10.94	25.86	46.00	-20.14	Peak	
5 *	485.9000	35.67	-8.91	26.76	46.00	-19.24	Peak	
6	552.8300	32.68	-6.20	26.48	46.00	-19.52	Peak	

Test Mode: UNII-2A/TX A Mode 5260MHz

Vertical

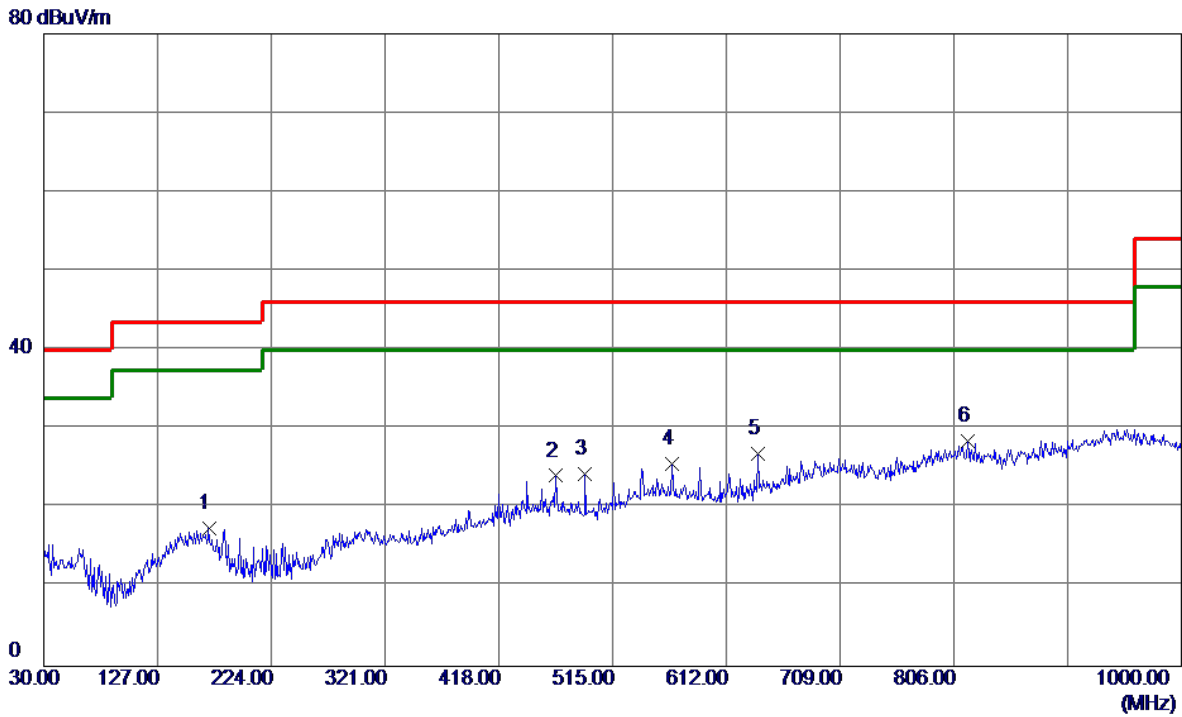

No.	Freq. MHz	Reading Level dBuV/m	Correct Factor dB	Measure ment dBuV/m	Limit dBuV/m	Margin dB	Detector	Comment
1	170.6500	29.49	-12.01	17.48	43.50	-26.02	Peak	
2	466.5000	32.56	-8.48	24.08	46.00	-21.92	Peak	
3	491.7200	33.30	-9.04	24.26	46.00	-21.74	Peak	
4	565.4400	32.03	-6.41	25.62	46.00	-20.38	Peak	
5	639.1599	32.98	-6.09	26.89	46.00	-19.11	Peak	
6 *	817.6400	30.32	-1.88	28.44	46.00	-17.56	Peak	

Test Mode: UNII-2A/TX A Mode 5260MHz

Horizontal

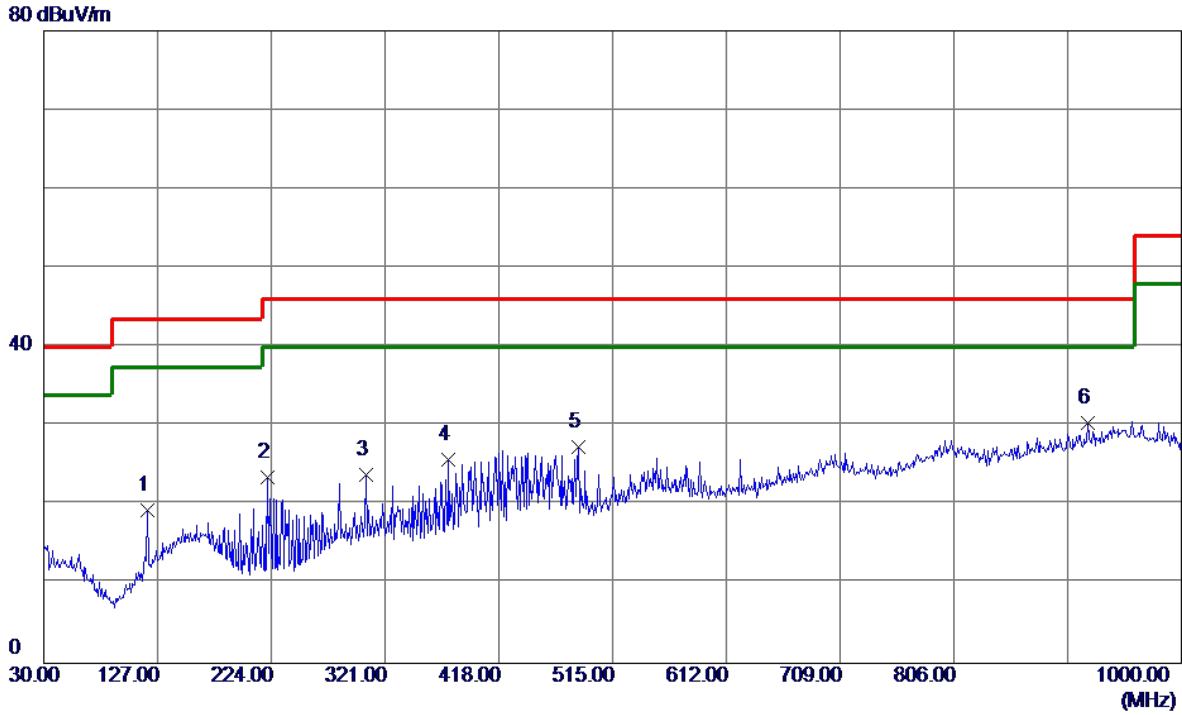

No.	Freq. MHz	Reading Level dBuV/m	Correct Factor dB	Measure ment dBuV/m	Limit dBuV/m	Margin dB	Detector	Comment
1	118.2700	35.02	-15.60	19.42	43.50	-24.08	Peak	
2	221.0900	39.10	-15.59	23.51	46.00	-22.49	Peak	
3	304.5100	34.99	-11.18	23.81	46.00	-22.19	Peak	
4	375.3200	36.70	-10.94	25.76	46.00	-20.24	Peak	
5	485.9000	36.27	-8.91	27.36	46.00	-18.64	Peak	
6 *	920.4600	30.74	-0.28	30.46	46.00	-15.54	Peak	

Test Mode: UNII-2A/TX A Mode 5300MHz

Vertical

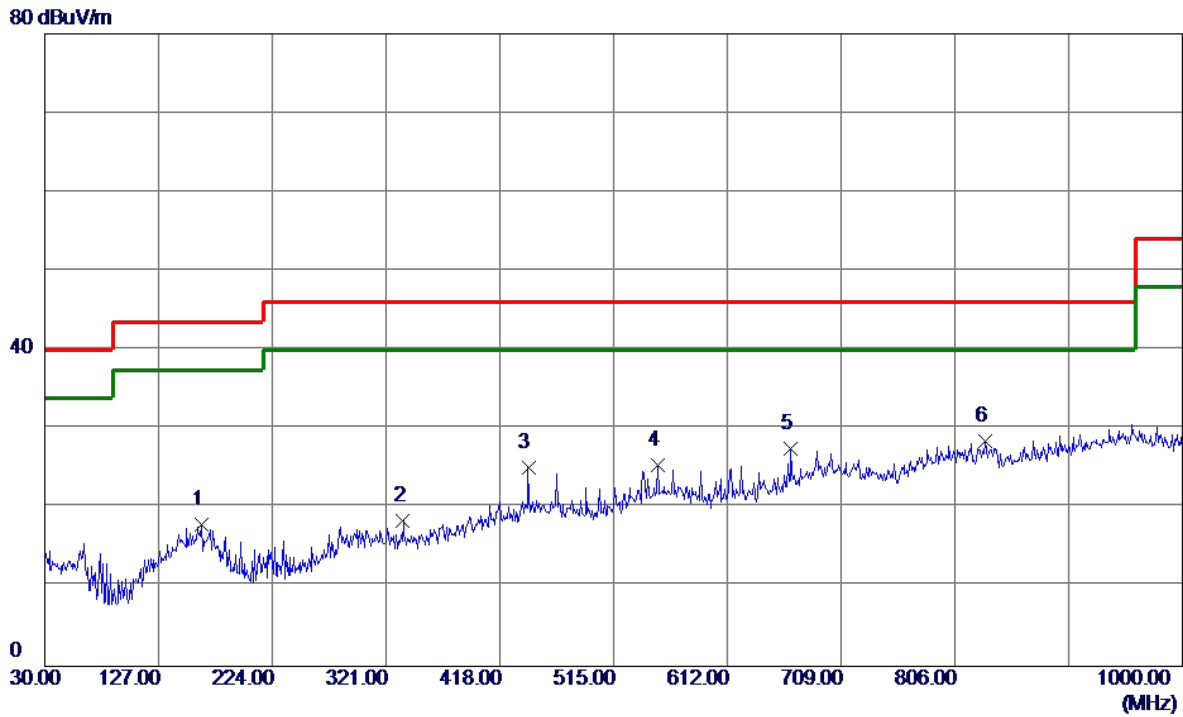

No.	Freq. MHz	Reading Level dBuV/m	Correct Factor dB	Measure ment dBuV/m	Limit dBuV/m	Margin dB	Detector	Comment
1	163.8600	29.41	-11.53	17.88	43.50	-25.62	Peak	
2	335.5500	30.03	-11.62	18.41	46.00	-27.59	Peak	
3	442.2500	33.47	-8.42	25.05	46.00	-20.95	Peak	
4	552.8300	31.62	-6.20	25.42	46.00	-20.58	Peak	
5	666.3200	32.56	-5.05	27.51	46.00	-18.49	Peak	
6 *	832.1900	30.50	-2.09	28.41	46.00	-17.59	Peak	

Test Mode: UNII-2A/TX A Mode 5300MHz

Horizontal

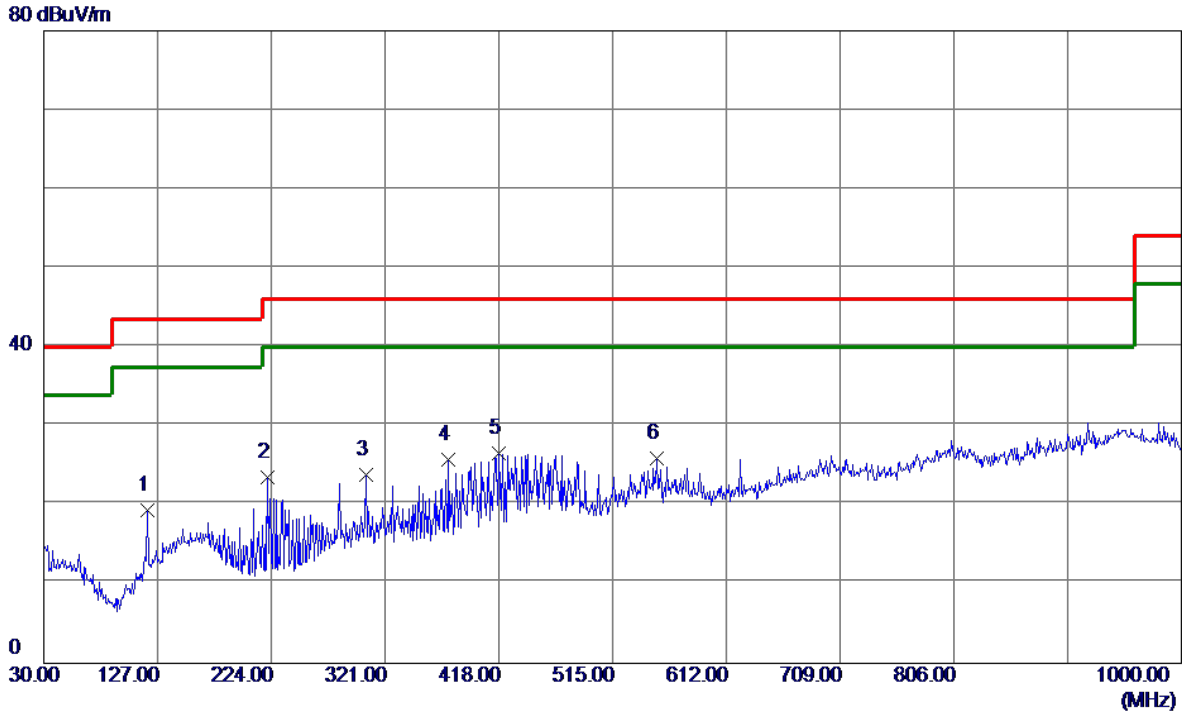

No.	Freq. MHz	Reading Level dBuV/m	Correct Factor dB	Measure ment dBuV/m	Limit dBuV/m	Margin dB	Detector	Comment
1	118.2700	35.02	-15.60	19.42	43.50	-24.08	Peak	
2	221.0900	39.10	-15.59	23.51	46.00	-22.49	Peak	
3	304.5100	34.99	-11.18	23.81	46.00	-22.19	Peak	
4	375.3200	36.70	-10.94	25.76	46.00	-20.24	Peak	
5 *	418.0000	36.01	-9.38	26.63	46.00	-19.37	Peak	
6	552.8300	32.18	-6.20	25.98	46.00	-20.02	Peak	

Test Mode: UNII-2A/TX A Mode 5320MHz

Vertical

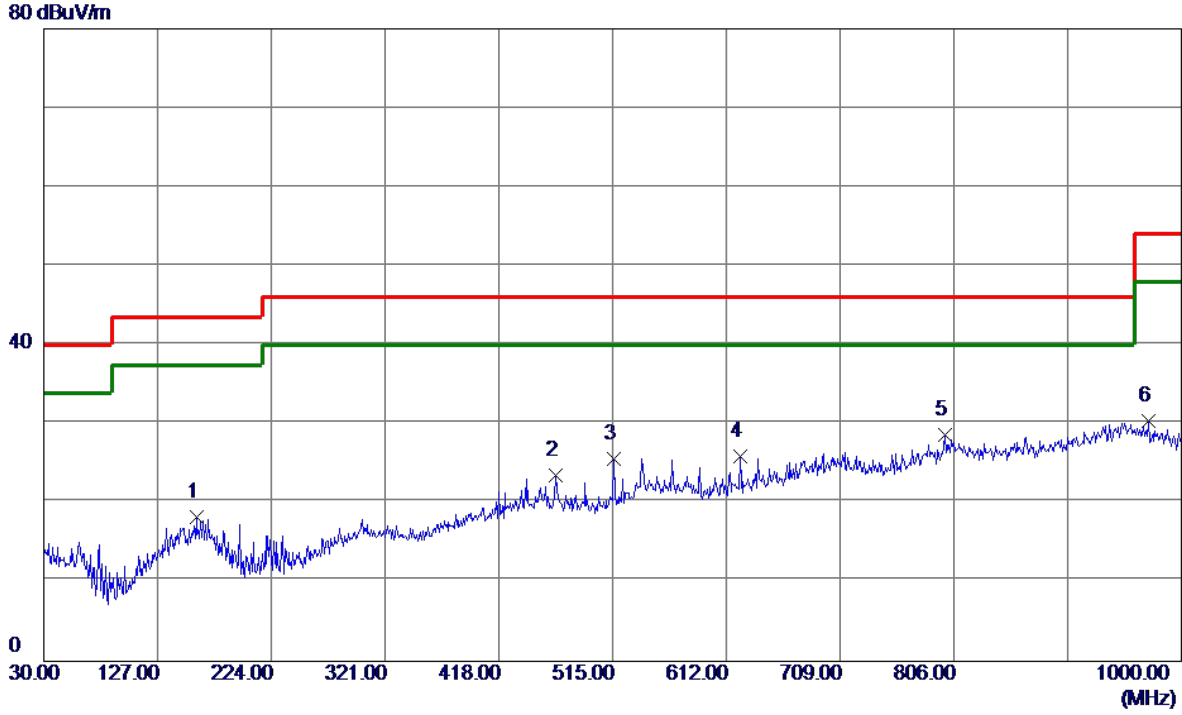

No.	Freq. MHz	Reading Level dBuV/m	Correct Factor dB	Measure ment dBuV/m	Limit dBuV/m	Margin dB	Detector	Comment
1	159.9800	29.56	-11.30	18.26	43.50	-25.24	Peak	
2	466.5000	31.97	-8.48	23.49	46.00	-22.51	Peak	
3	515.9699	33.85	-8.25	25.60	46.00	-20.40	Peak	
4	623.6400	32.32	-6.45	25.87	46.00	-20.13	Peak	
5 *	798.2400	30.32	-1.73	28.59	46.00	-17.41	Peak	
6	971.8700	29.92	0.42	30.34	54.00	-23.66	Peak	

Test Mode: UNII-2A/TX A Mode 5320MHz

Horizontal

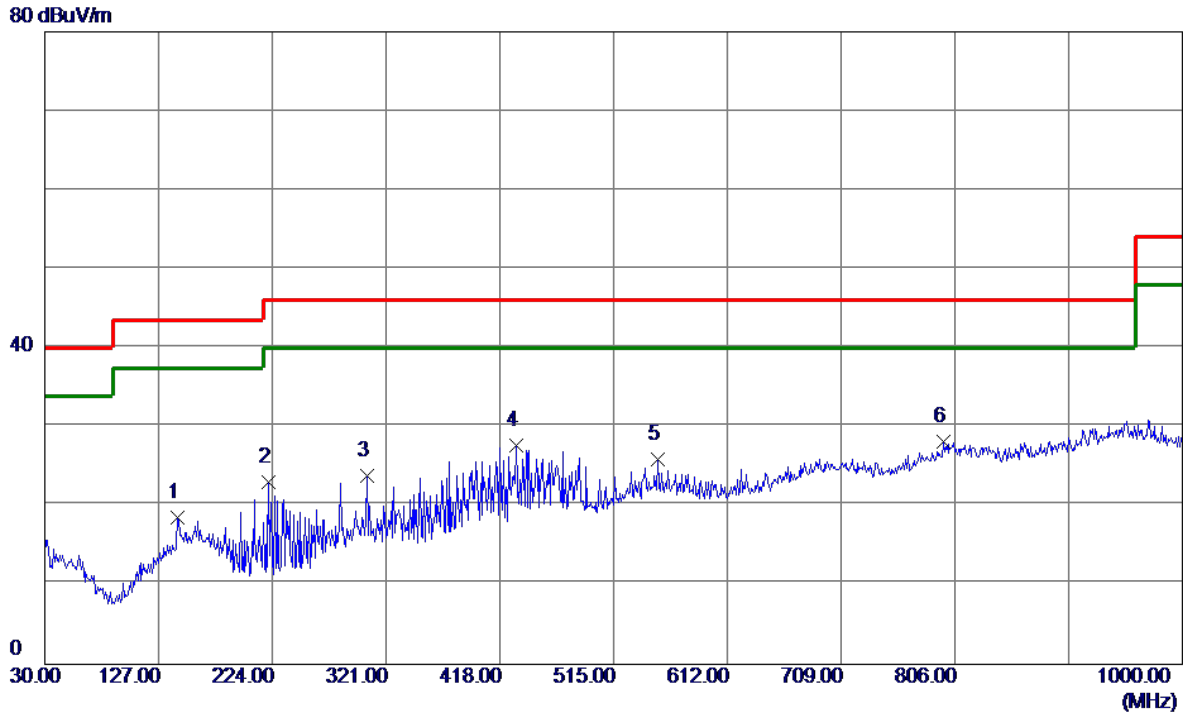

No.	Freq. MHz	Reading Level dBuV/m	Correct Factor dB	Measure ment dBuV/m	Limit dBuV/m	Margin dB	Detector	Comment
1	143.4900	31.07	-12.56	18.51	43.50	-24.99	Peak	
2	221.0900	38.56	-15.59	22.97	46.00	-23.03	Peak	
3	304.5100	35.03	-11.18	23.85	46.00	-22.15	Peak	
4	431.5800	36.47	-8.84	27.63	46.00	-18.37	Peak	
5	552.8300	32.10	-6.20	25.90	46.00	-20.10	Peak	
6 *	796.3000	30.06	-1.84	28.22	46.00	-17.78	Peak	

Test Mode: UNII-2C/TX A Mode 5500MHz

Vertical

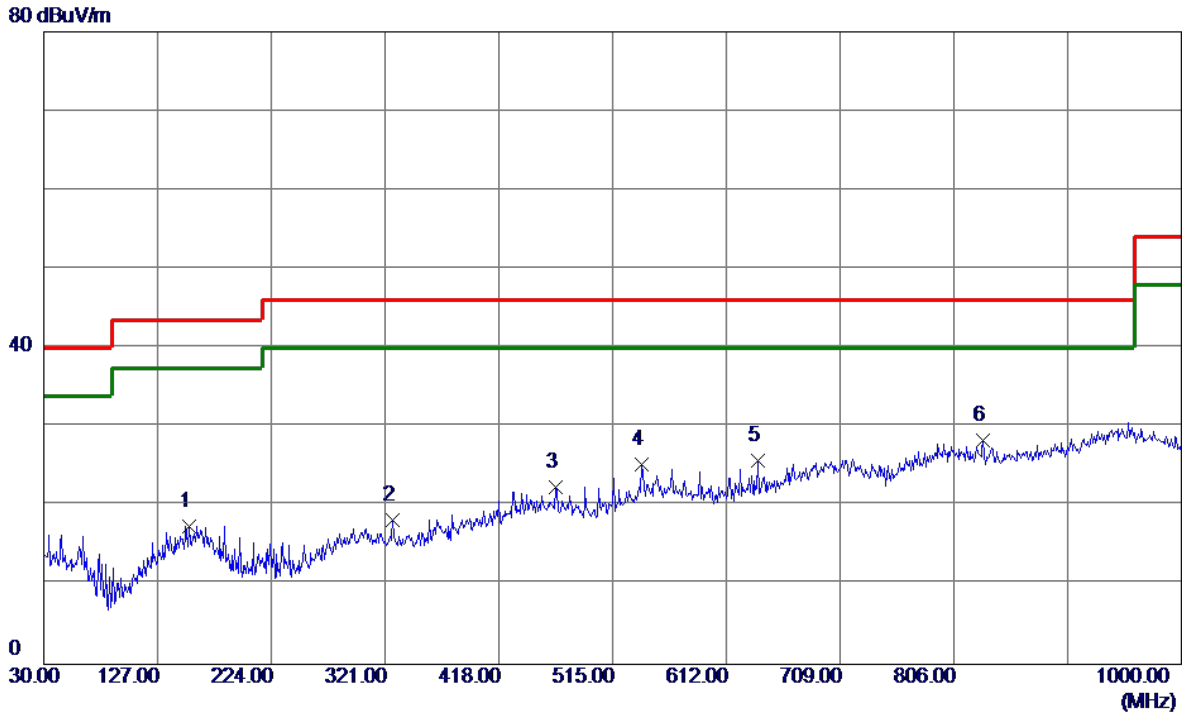

No.	Freq. MHz	Reading Level dBuV/m	Correct Factor dB	Measure ment dBuV/m	Limit dBuV/m	Margin dB	Detector	Comment
1	154.1600	29.30	-11.81	17.49	43.50	-26.01	Peak	
2	327.7900	29.71	-11.51	18.20	46.00	-27.80	Peak	
3	466.5000	30.89	-8.48	22.41	46.00	-23.59	Peak	
4	540.2199	31.96	-6.75	25.21	46.00	-20.79	Peak	
5	639.1599	31.86	-6.09	25.77	46.00	-20.23	Peak	
6 *	831.2199	30.42	-2.08	28.34	46.00	-17.66	Peak	

Test Mode: UNII-2C/TX A Mode 5500MHz

Horizontal

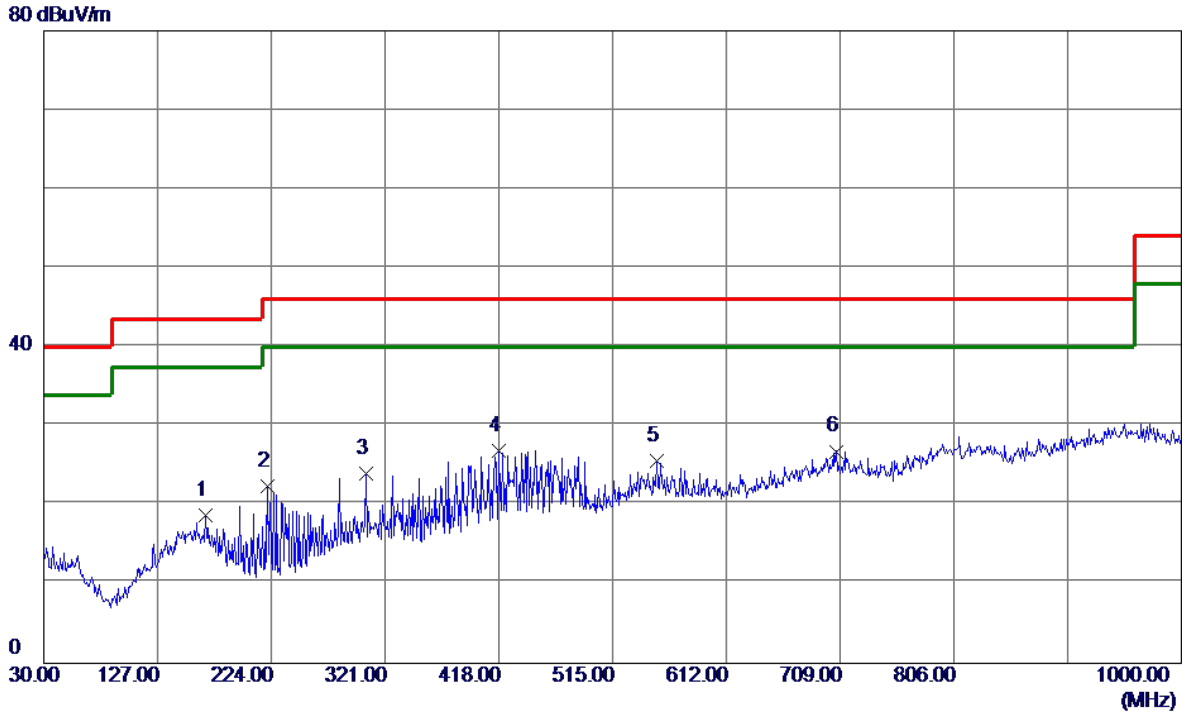

No.	Freq. MHz	Reading Level dBuV/m	Correct Factor dB	Measure ment dBuV/m	Limit dBuV/m	Margin dB	Detector	Comment
1	167.7400	30.43	-11.77	18.66	43.50	-24.84	Peak	
2	221.0900	37.92	-15.59	22.33	46.00	-23.67	Peak	
3	304.5100	35.11	-11.18	23.93	46.00	-22.07	Peak	
4 *	418.0000	36.33	-9.38	26.95	46.00	-19.05	Peak	
5	552.8300	31.85	-6.20	25.65	46.00	-20.35	Peak	
6	706.0900	30.36	-3.56	26.80	46.00	-19.20	Peak	

Test Mode: UNII-2C/TX A Mode 5580MHz

Vertical

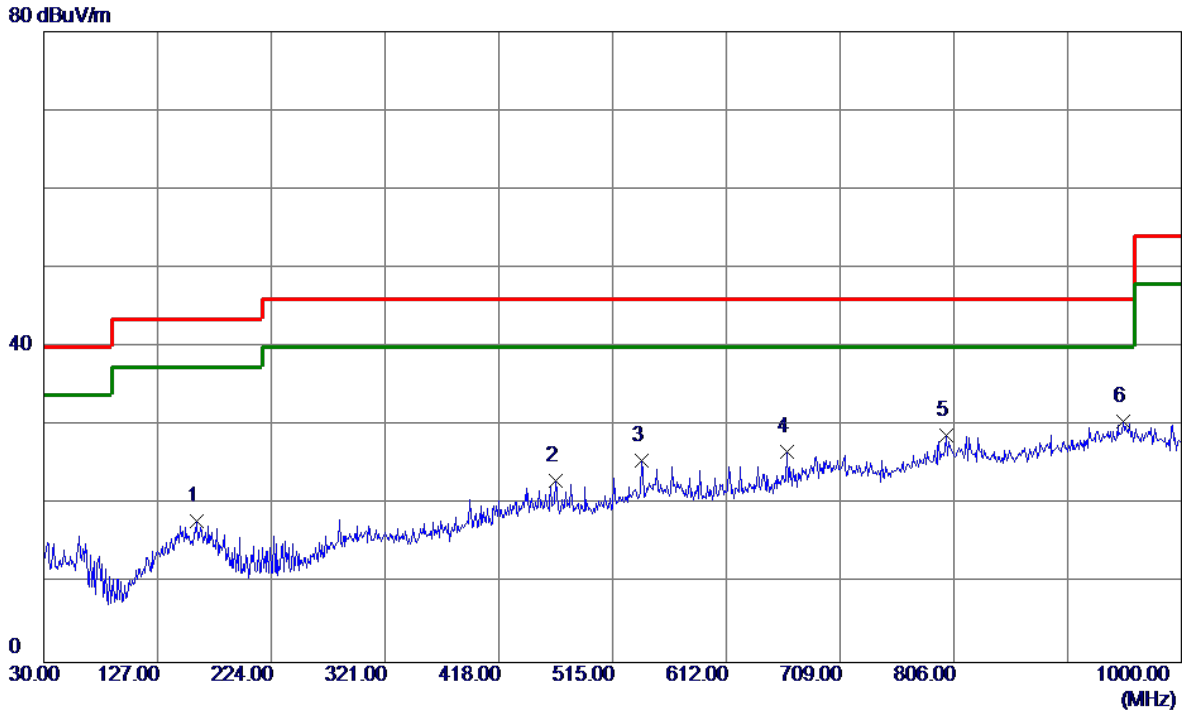

No.	Freq. MHz	Reading Level dBuV/m	Correct Factor dB	Measure ment dBuV/m	Limit dBuV/m	Margin dB	Detector	Comment
1	159.9800	29.29	-11.30	17.99	43.50	-25.51	Peak	
2	466.5000	31.54	-8.48	23.06	46.00	-22.94	Peak	
3	540.2199	32.31	-6.75	25.56	46.00	-20.44	Peak	
4	663.4099	31.84	-5.19	26.65	46.00	-19.35	Peak	
5	799.2100	30.47	-1.67	28.80	46.00	-17.20	Peak	
6 *	950.5300	29.66	0.91	30.57	46.00	-15.43	Peak	

Test Mode: UNII-2C/TX A Mode 5580MHz

Horizontal

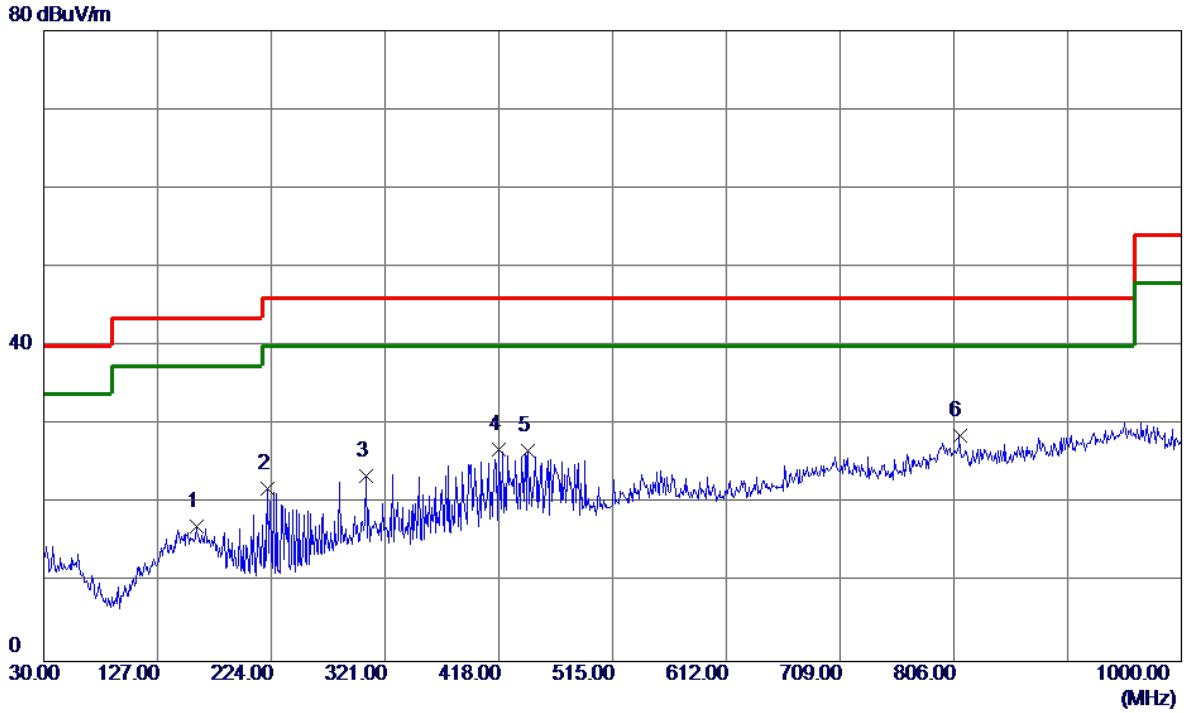

No.	Freq. MHz	Reading Level dBuV/m	Correct Factor dB	Measure ment dBuV/m	Limit dBuV/m	Margin dB	Detector	Comment
1	159.9800	28.48	-11.30	17.18	43.50	-26.32	Peak	
2	221.0900	37.47	-15.59	21.88	46.00	-24.12	Peak	
3	304.5100	34.72	-11.18	23.54	46.00	-22.46	Peak	
4	418.0000	36.33	-9.38	26.95	46.00	-19.05	Peak	
5	443.2200	35.07	-8.38	26.69	46.00	-19.31	Peak	
6 *	810.8500	30.40	-1.78	28.62	46.00	-17.38	Peak	

Test Mode: UNII-2C/TX A Mode 5700MHz

Vertical

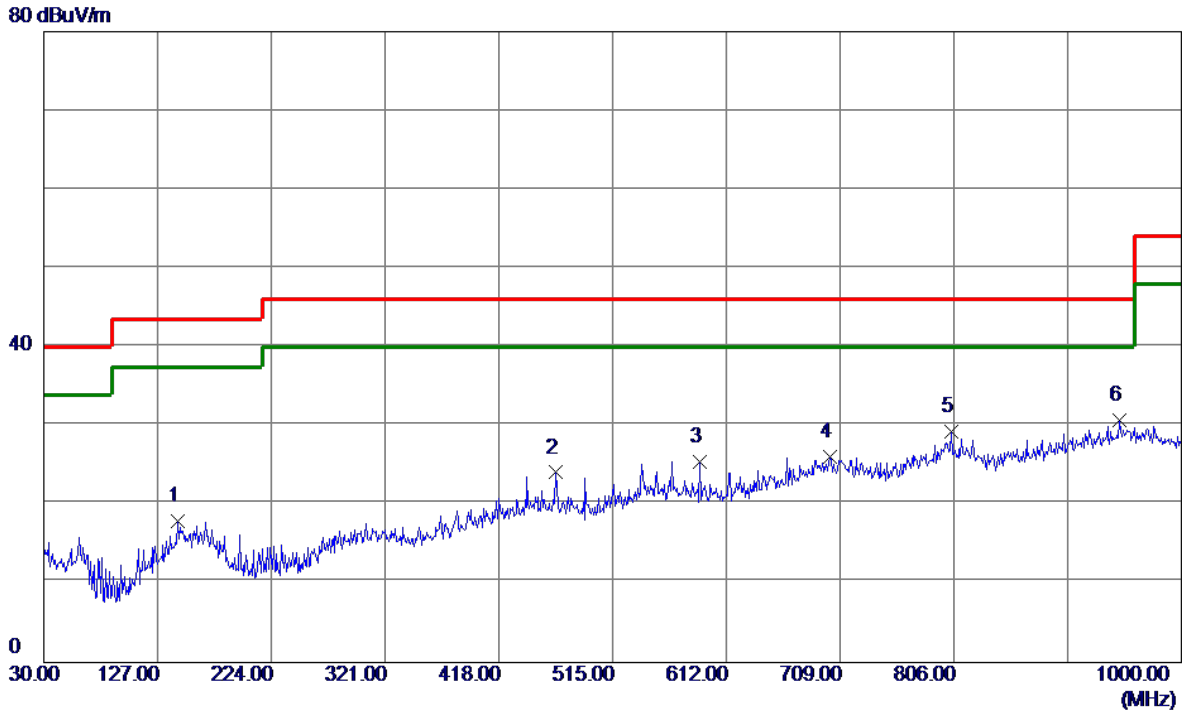

No.	Freq. MHz	Reading Level dBuV/m	Correct Factor dB	Measure ment dBuV/m	Limit dBuV/m	Margin dB	Detector	Comment
1	144.4600	30.36	-12.50	17.86	43.50	-25.64	Peak	
2	466.5000	32.56	-8.48	24.08	46.00	-21.92	Peak	
3	589.6900	32.26	-6.82	25.44	46.00	-20.56	Peak	
4	700.2700	29.49	-3.41	26.08	46.00	-19.92	Peak	
5	804.0600	30.94	-1.68	29.26	46.00	-16.74	Peak	
6 *	947.6200	29.91	0.83	30.74	46.00	-15.26	Peak	

Test Mode: UNII-2C/TX A Mode 5700MHz

Horizontal

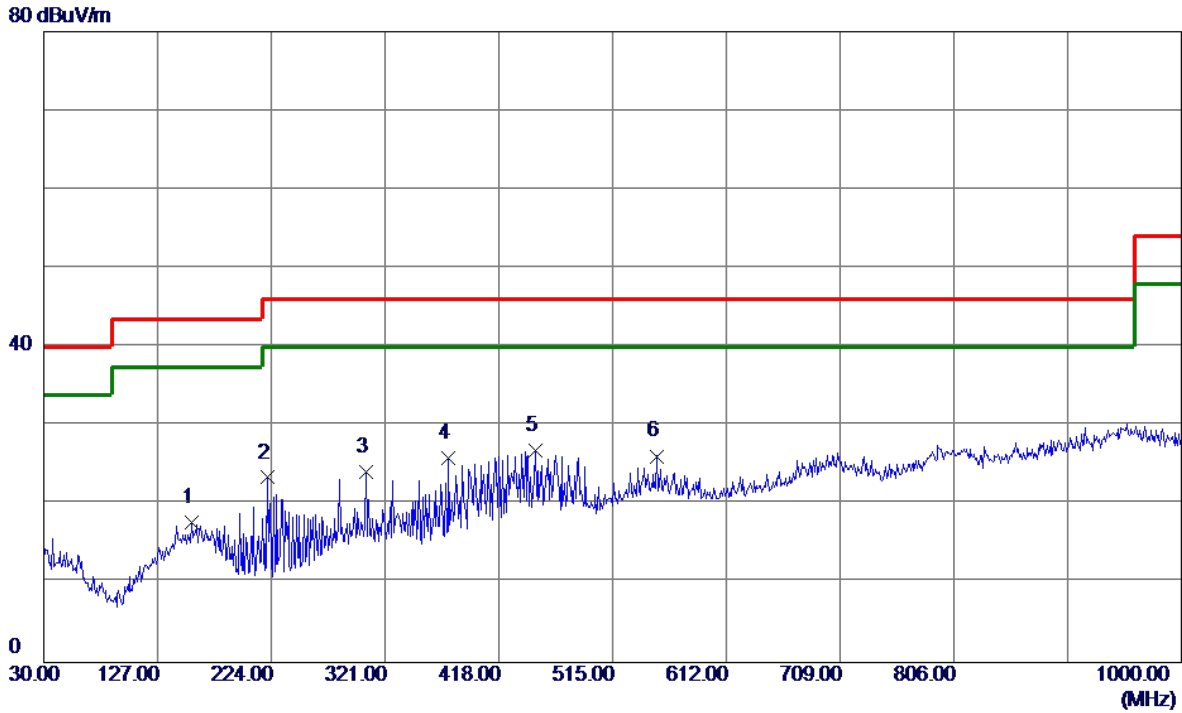

No.	Freq. MHz	Reading Level dBuV/m	Correct Factor dB	Measure ment dBuV/m	Limit dBuV/m	Margin dB	Detector	Comment
1	156.1000	29.45	-11.64	17.81	43.50	-25.69	Peak	
2	221.0900	39.03	-15.59	23.44	46.00	-22.56	Peak	
3	304.5100	35.36	-11.18	24.18	46.00	-21.82	Peak	
4	375.3200	36.91	-10.94	25.97	46.00	-20.03	Peak	
5 *	449.0400	35.01	-8.15	26.86	46.00	-19.14	Peak	
6	552.8300	32.36	-6.20	26.16	46.00	-19.84	Peak	

Test Mode: UNII-3/TX A Mode 5745MHz

Vertical

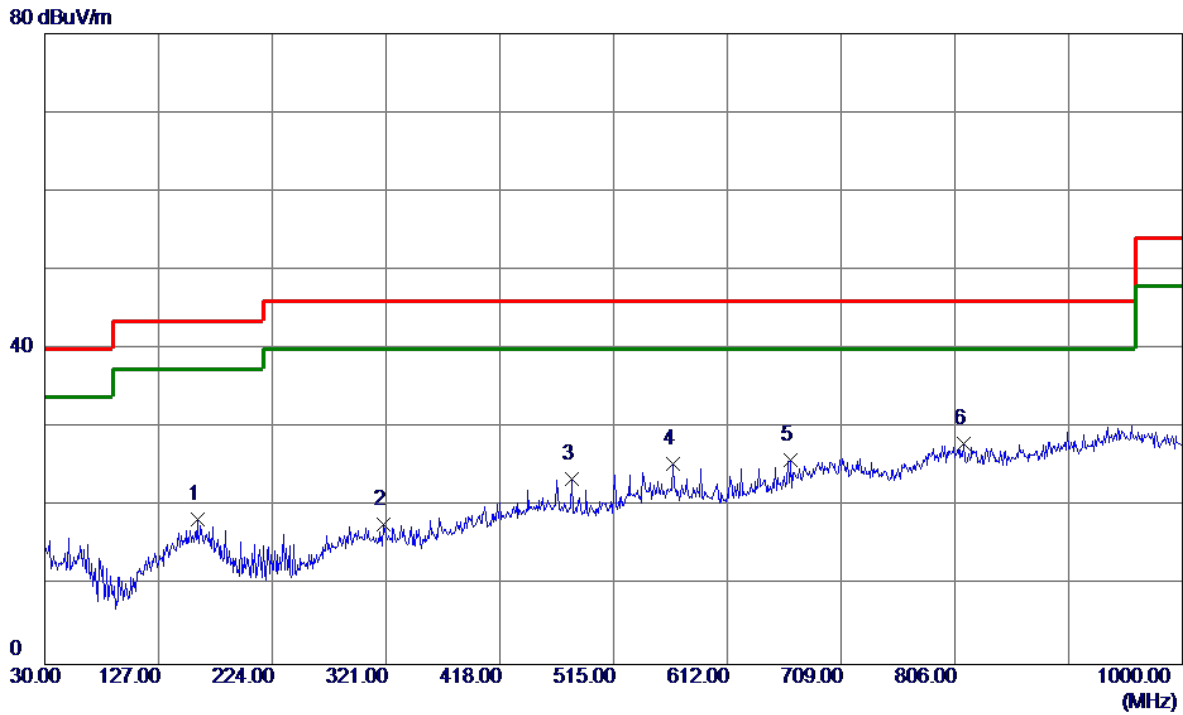

No.	Freq. MHz	Reading Level dBuV/m	Correct Factor dB	Measure ment dBuV/m	Limit dBuV/m	Margin dB	Detector	Comment
1	159.9800	29.69	-11.30	18.39	43.50	-25.11	Peak	
2	319.0600	29.16	-11.39	17.77	46.00	-28.23	Peak	
3	479.1100	32.24	-8.76	23.48	46.00	-22.52	Peak	
4	565.4400	31.87	-6.41	25.46	46.00	-20.54	Peak	
5	666.3200	31.00	-5.05	25.95	46.00	-20.05	Peak	
6 *	813.7600	29.78	-1.82	27.96	46.00	-18.04	Peak	

Test Mode: UNII-3/TX A Mode 5745MHz

Horizontal

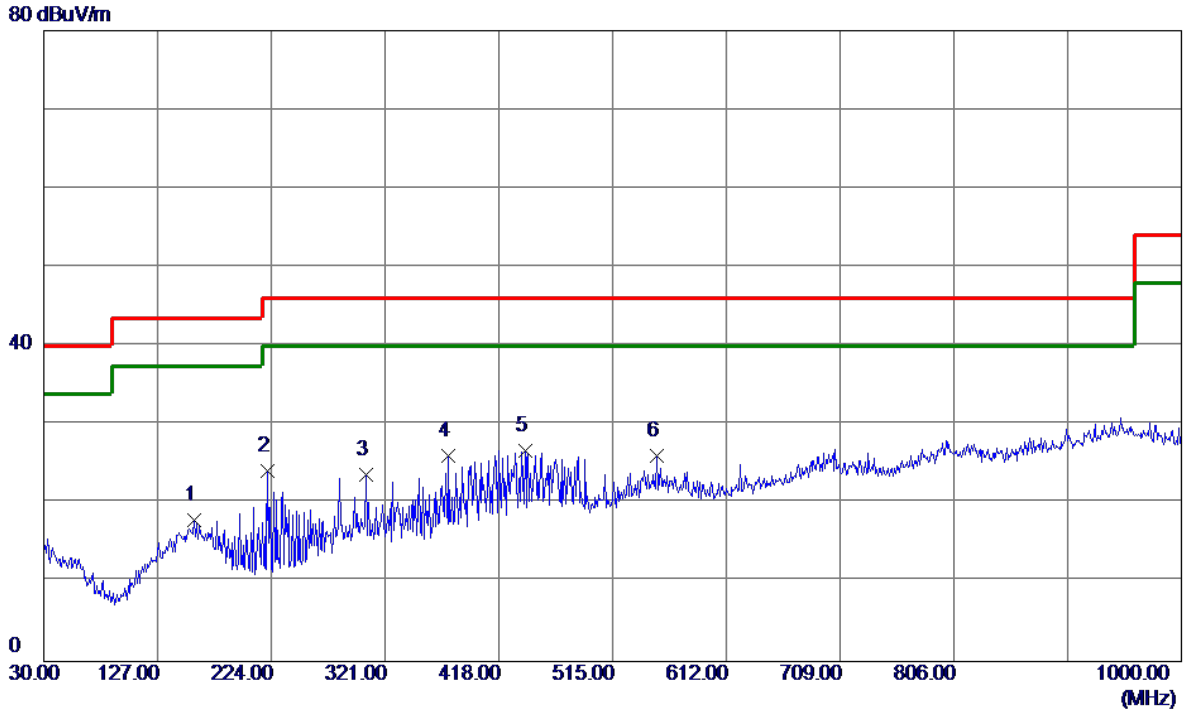

No.	Freq. MHz	Reading Level dBuV/m	Correct Factor dB	Measure ment dBuV/m	Limit dBuV/m	Margin dB	Detector	Comment
1	158.0399	29.46	-11.47	17.99	43.50	-25.51	Peak	
2	221.0900	39.72	-15.59	24.13	46.00	-21.87	Peak	
3	304.5100	34.84	-11.18	23.66	46.00	-22.34	Peak	
4	375.3200	36.97	-10.94	26.03	46.00	-19.97	Peak	
5 *	440.3100	35.21	-8.49	26.72	46.00	-19.28	Peak	
6	552.8300	32.34	-6.20	26.14	46.00	-19.86	Peak	

Test Mode: UNII-3/TX A Mode 5785MHz

Vertical

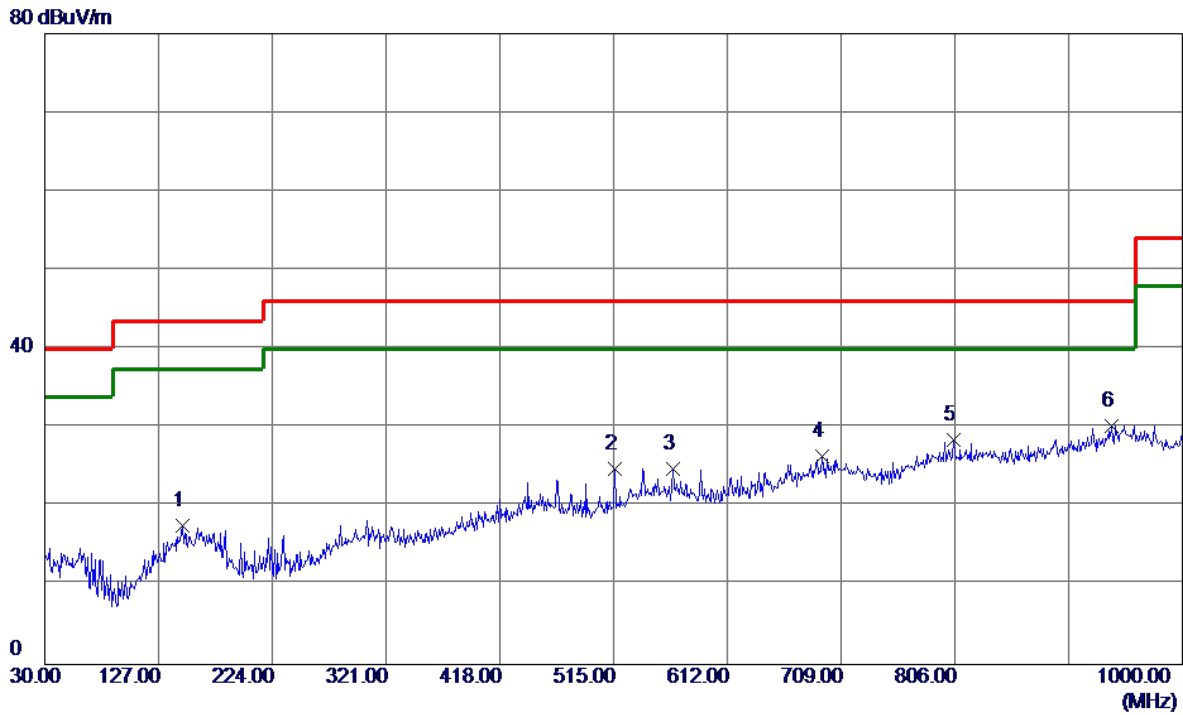

No.	Freq. MHz	Reading Level dBuV/m	Correct Factor dB	Measure ment dBuV/m	Limit dBuV/m	Margin dB	Detector	Comment
1	147.3700	29.97	-12.33	17.64	43.50	-25.86	Peak	
2	515.9699	32.99	-8.25	24.74	46.00	-21.26	Peak	
3	565.4400	31.29	-6.41	24.88	46.00	-21.12	Peak	
4	692.5100	30.10	-3.77	26.33	46.00	-19.67	Peak	
5	805.0300	30.12	-1.69	28.43	46.00	-17.57	Peak	
6 *	939.8600	29.72	0.51	30.23	46.00	-15.77	Peak	

Test Mode: UNII-3/TX A Mode 5785MHz

Horizontal

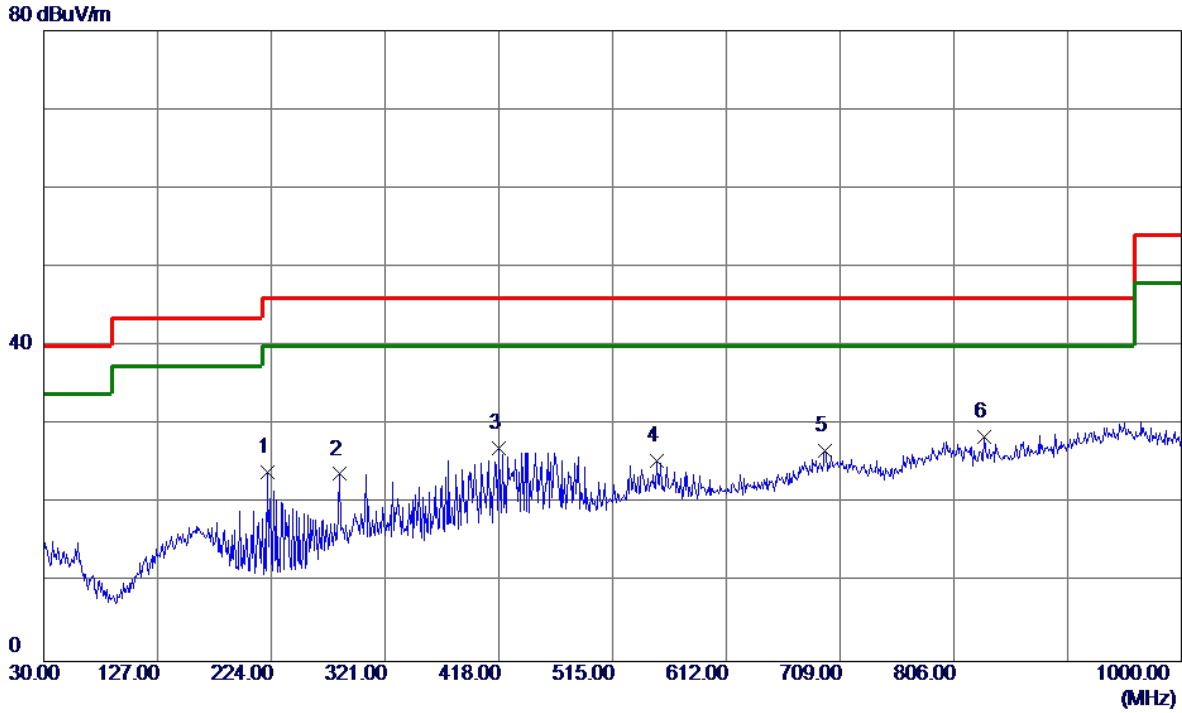

No.	Freq. MHz	Reading Level dBuV/m	Correct Factor dB	Measure ment dBuV/m	Limit dBuV/m	Margin dB	Detector	Comment
1	221.0900	39.62	-15.59	24.03	46.00	-21.97	Peak	
2	282.2000	35.76	-12.00	23.76	46.00	-22.24	Peak	
3	418.0000	36.35	-9.38	26.97	46.00	-19.03	Peak	
4	552.8300	31.71	-6.20	25.51	46.00	-20.49	Peak	
5	696.3900	30.26	-3.58	26.68	46.00	-19.32	Peak	
6 *	832.1900	30.63	-2.09	28.54	46.00	-17.46	Peak	

Test Mode: UNII-3/TX A Mode 5825MHz

Vertical

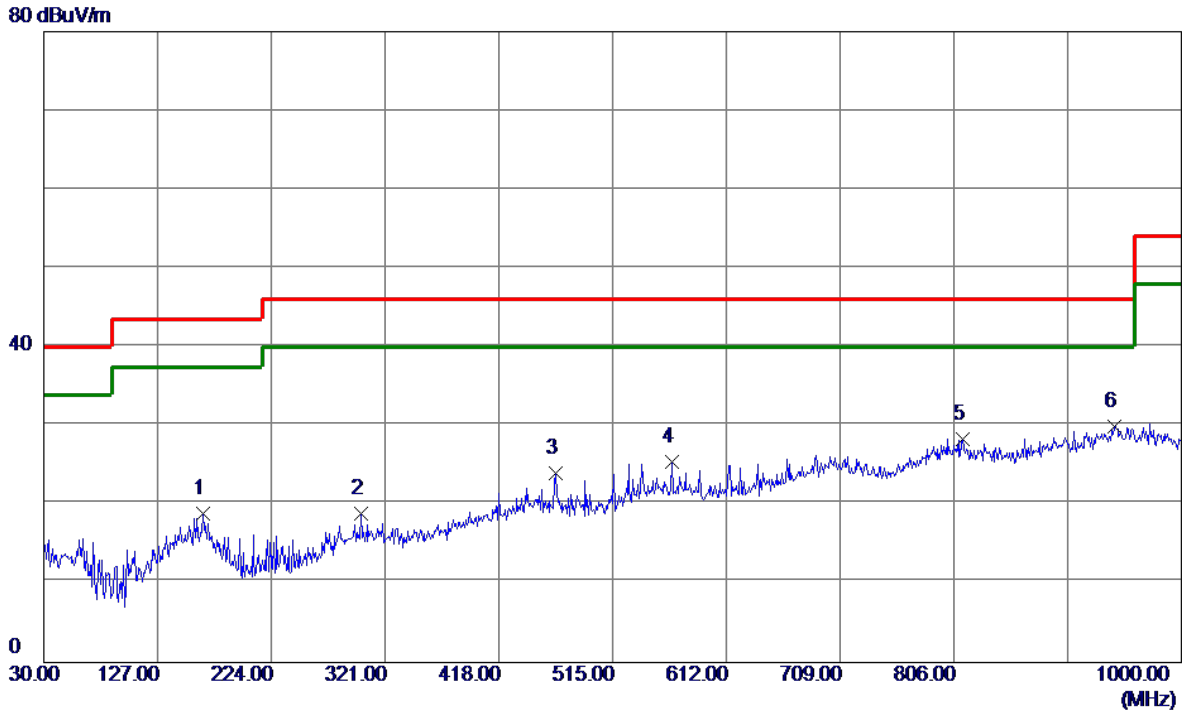

No.	Freq. MHz	Reading Level dBuV/m	Correct Factor dB	Measure ment dBuV/m	Limit dBuV/m	Margin dB	Detector	Comment
1	165.8000	30.48	-11.65	18.83	43.50	-24.67	Peak	
2	300.6300	30.03	-11.13	18.90	46.00	-27.10	Peak	
3	466.5000	32.44	-8.48	23.96	46.00	-22.04	Peak	
4	565.4400	31.82	-6.41	25.41	46.00	-20.59	Peak	
5	813.7600	30.18	-1.82	28.36	46.00	-17.64	Peak	
6 *	942.7700	29.28	0.63	29.91	46.00	-16.09	Peak	

Test Mode: UNII-3/TX A Mode 5825MHz

Horizontal

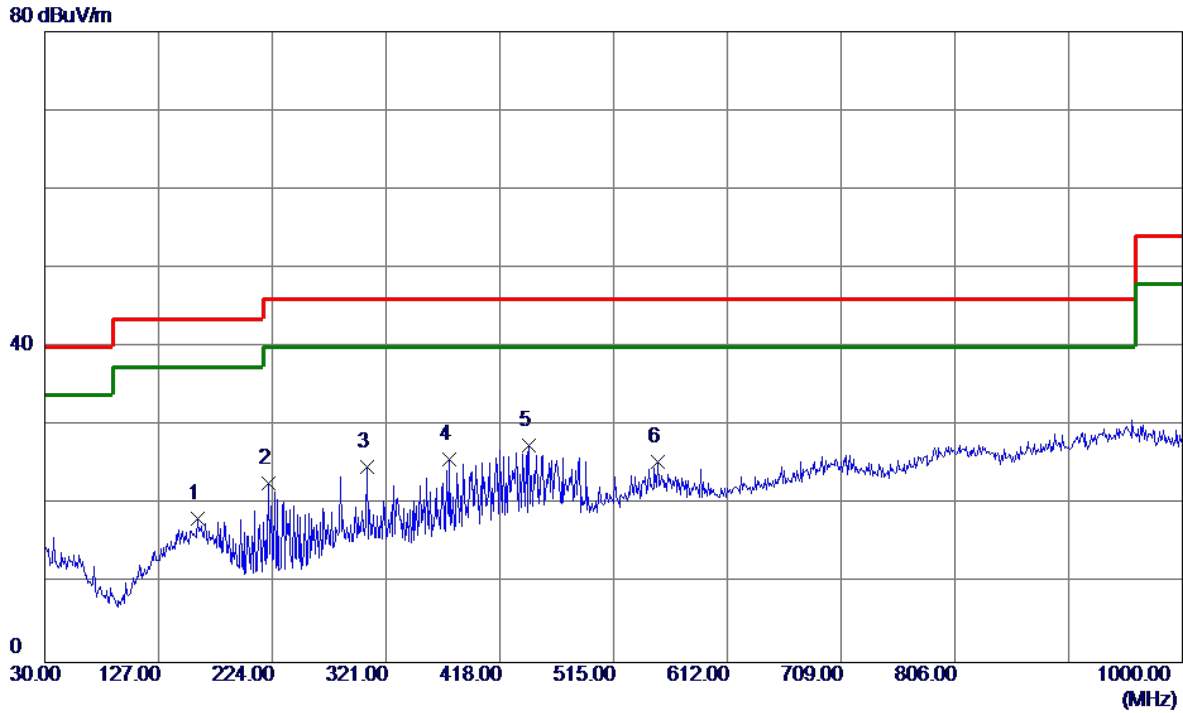

No.	Freq. MHz	Reading Level dBuV/m	Correct Factor dB	Measure ment dBuV/m	Limit dBuV/m	Margin dB	Detector	Comment
1	159.9800	29.61	-11.30	18.31	43.50	-25.19	Peak	
2	221.0900	38.24	-15.59	22.65	46.00	-23.35	Peak	
3	304.5100	36.06	-11.18	24.88	46.00	-21.12	Peak	
4	375.3200	36.74	-10.94	25.80	46.00	-20.20	Peak	
5 *	443.2200	35.88	-8.38	27.50	46.00	-18.50	Peak	
6	552.8300	31.62	-6.20	25.42	46.00	-20.58	Peak	

APPENDIX D - RADIATED EMISSION (ABOVE 1000MHZ)

Orthogonal Axis:	X
Test Mode:	UNII-1/ TX A Mode 5180MHz

Vertical

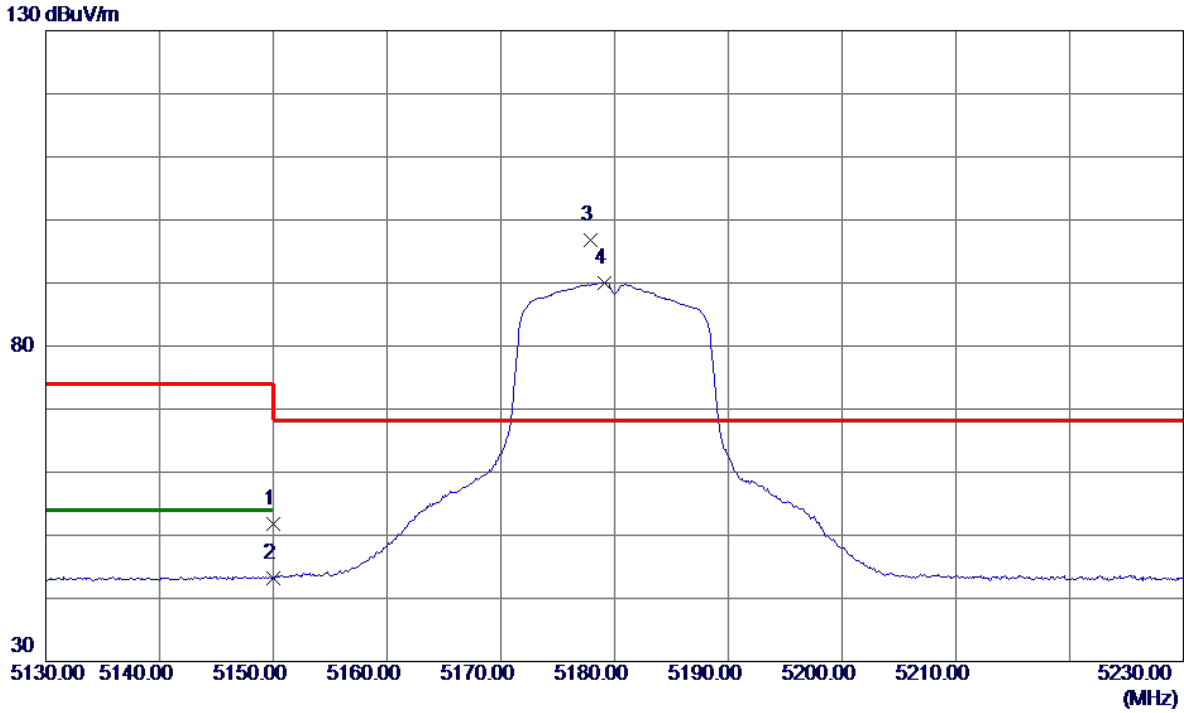

No.	Freq. MHz	Reading Level dBuV/m	Correct Factor dB	Measure ment dBuV/m	Limit dBuV/m	Margin dB	Detector	Comment
1	5150.0000	35.16	16.65	51.81	74.00	-22.19	Peak	
2	5150.0000	26.61	16.65	43.26	54.00	-10.74	AVG	
3 *	5177.9000	79.98	16.73	96.71	68.30	28.41	Peak	No Limit
4	5179.1000	73.31	16.73	90.04	999.00	-908.96	AVG	No Limit

Orthogonal Axis:	X
Test Mode:	UNII-1/ TX A Mode 5180MHz

Vertical

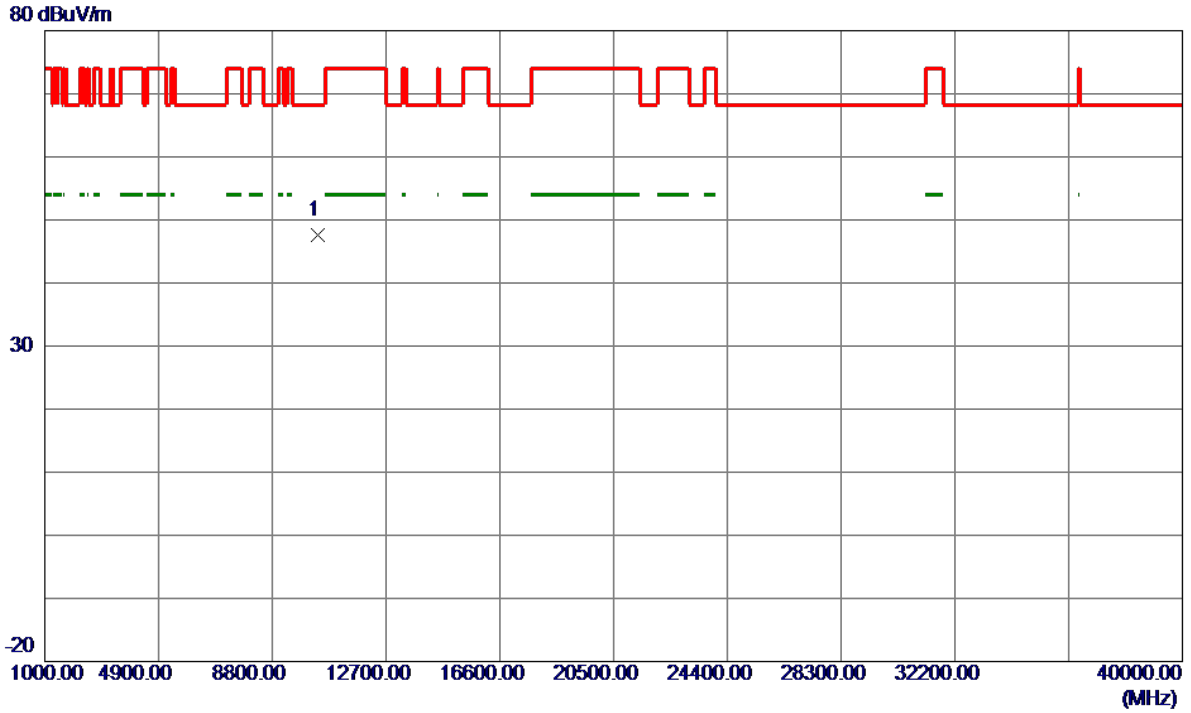

No.	Freq. MHz	Reading Level dBuV/m	Correct Factor dB	Measure ment dBuV/m	Limit dBuV/m	Margin dB	Detector	Comment
1 *	10358.1400	32.81	14.84	47.65	68.30	-20.65	Peak	

Orthogonal Axis:	X
Test Mode:	UNII-1/ TX A Mode 5180MHz

Horizontal

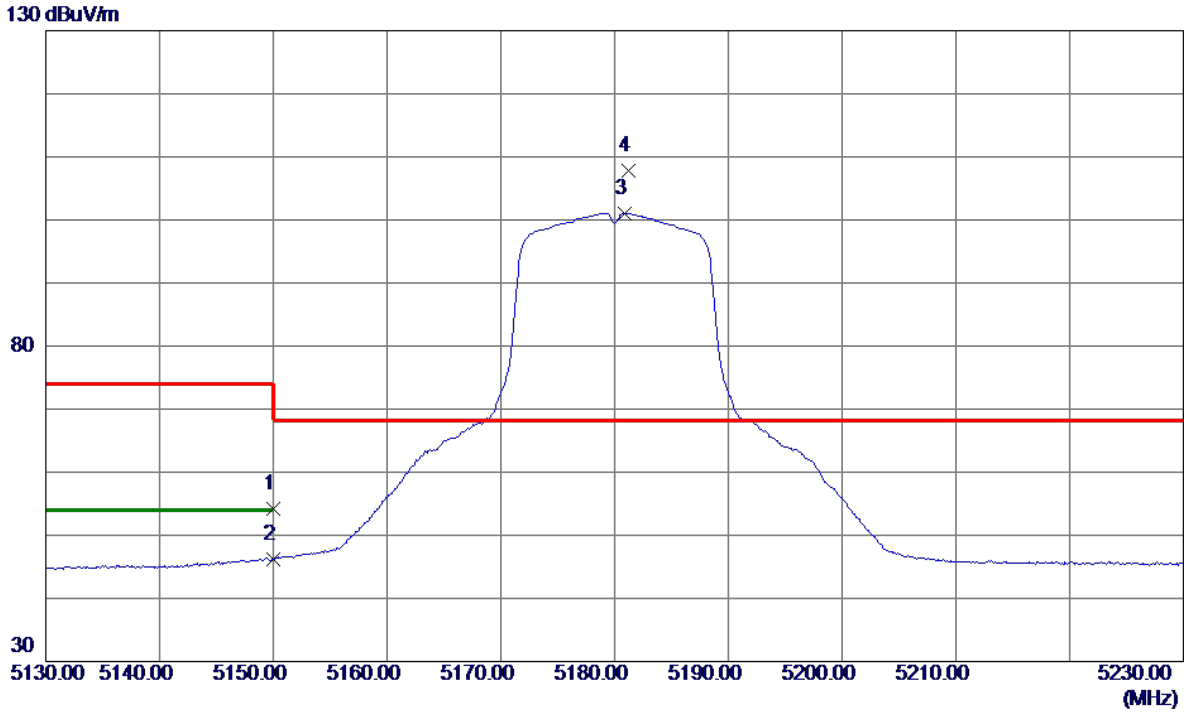

No.	Freq. MHz	Reading Level dBuV/m	Correct Factor dB	Measurement dBuV/m	Limit dBuV/m	Margin dB	Detector	Comment
1	5150.0000	37.53	16.65	54.18	74.00	-19.82	Peak	
2	5150.0000	29.57	16.65	46.22	54.00	-7.78	AVG	
3	5180.9000	84.37	16.73	101.10	999.00	-897.90	AVG	No Limit
4 *	5181.2000	91.00	16.73	107.73	68.30	39.43	Peak	No Limit

Orthogonal Axis:	X
Test Mode:	UNII-1/ TX A Mode 5180MHz

Horizontal

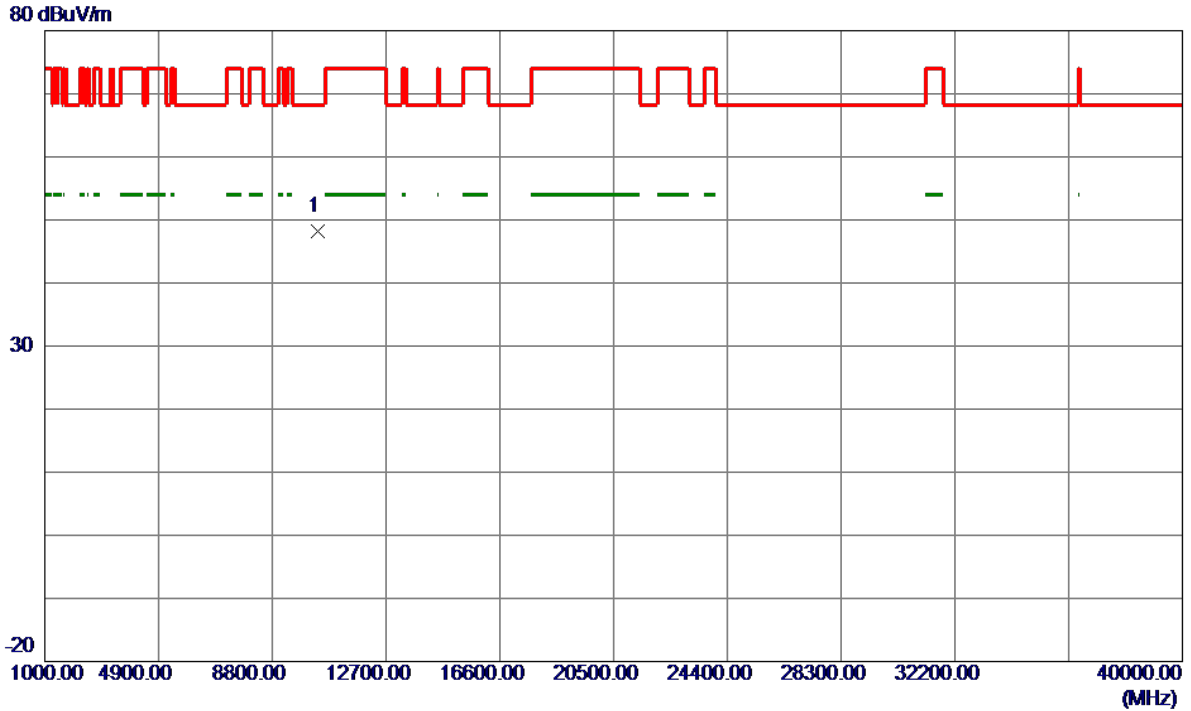

No.	Freq. MHz	Reading Level dBuV/m	Correct Factor dB	Measure ment dBuV/m	Limit dBuV/m	Margin dB	Detector	Comment
1 *	10359.6150	33.30	14.85	48.15	68.30	-20.15	Peak	

Orthogonal Axis:	X
Test Mode:	UNII-1/ TX A Mode 5200MHz

Vertical

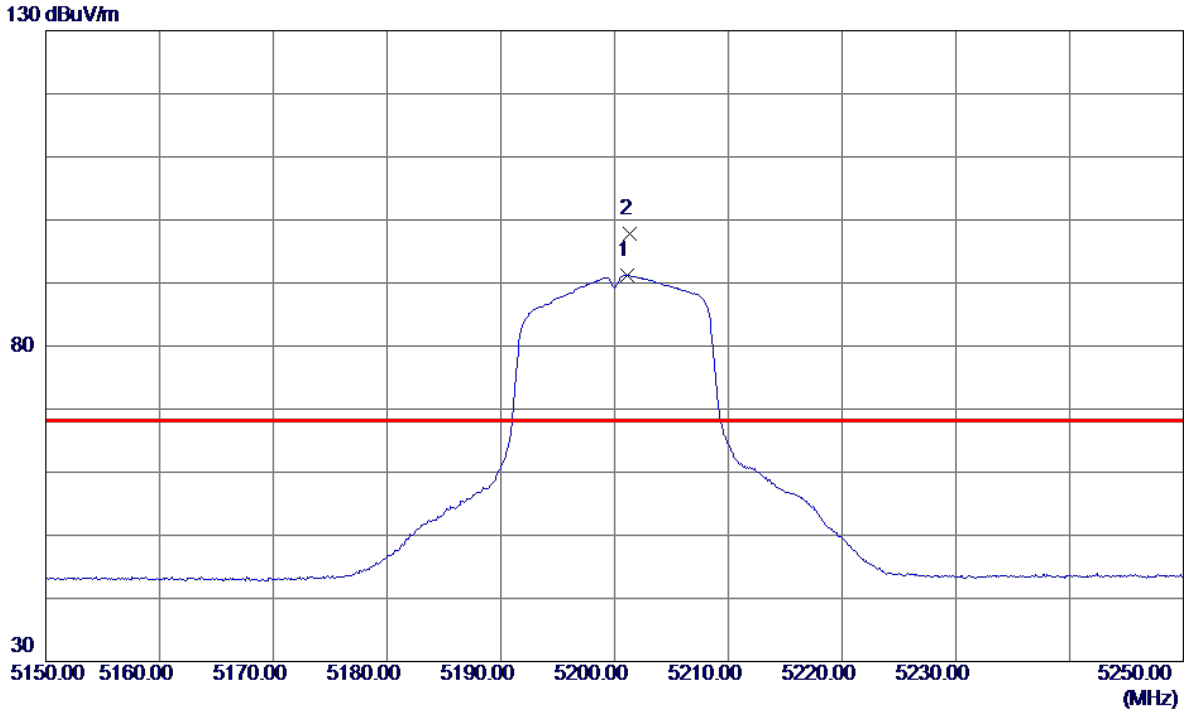

No.	Freq. MHz	Reading Level dBuV/m	Correct Factor dB	Measure ment dBuV/m	Limit dBuV/m	Margin dB	Detector	Comment
1	5201.1000	74.45	16.79	91.24	999.00	-907.76	AVG	No Limit
2 *	5201.3000	80.99	16.79	97.78	68.30	29.48	Peak	No Limit

Orthogonal Axis:	X
Test Mode:	UNII-1/ TX A Mode 5200MHz

Vertical

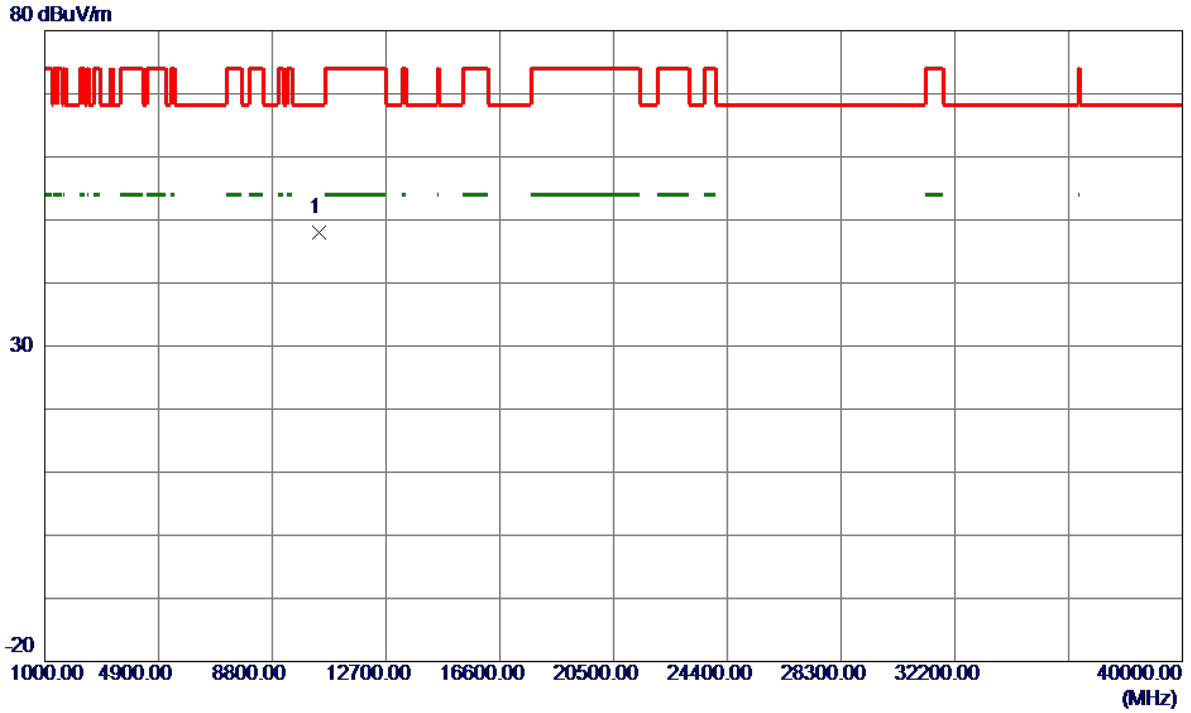

No.	Freq. MHz	Reading Level dBuV/m	Correct Factor dB	Measure ment dBuV/m	Limit dBuV/m	Margin dB	Detector	Comment
1	10400.4100	33.01	14.92	47.93	999.00	-951.07	AVG	

Orthogonal Axis:	X
Test Mode:	UNII-1/ TX A Mode 5200MHz

Horizontal

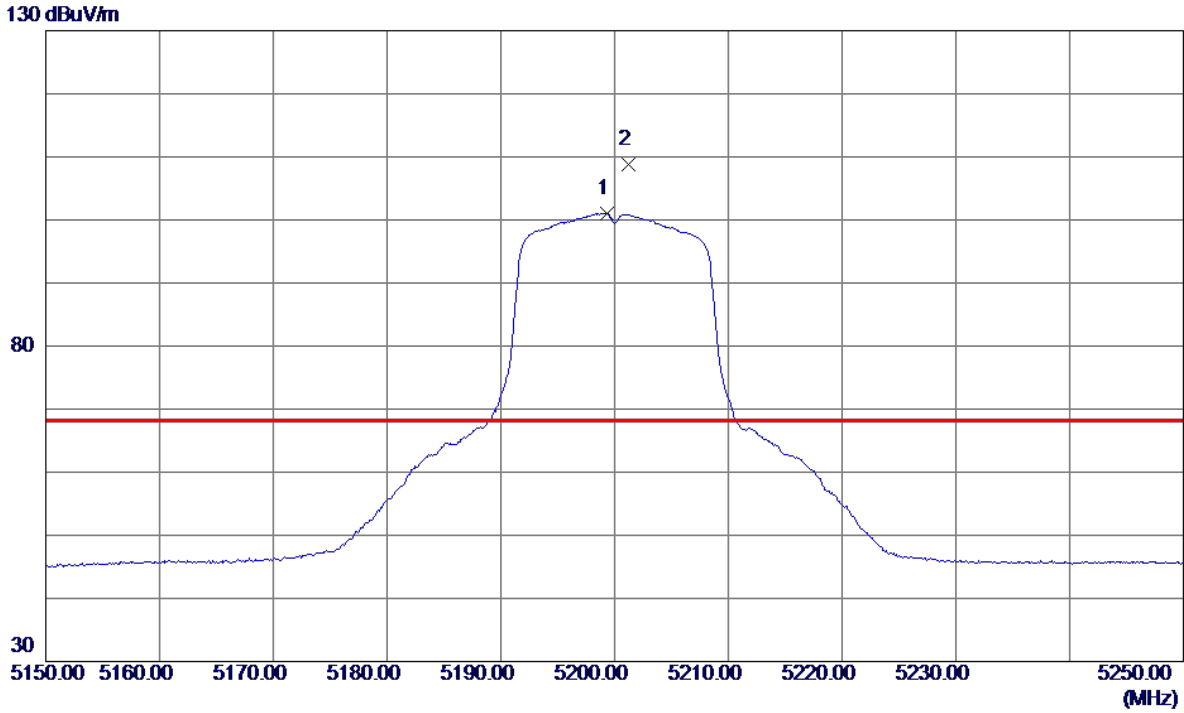

No.	Freq. MHz	Reading Level dBuV/m	Correct Factor dB	Measure ment dBuV/m	Limit dBuV/m	Margin dB	Detector	Comment
1	5199.3000	84.31	16.79	101.10	999.00	-897.90	AVG	No Limit
2 *	5201.2000	92.08	16.79	108.87	68.30	40.57	Peak	No Limit

Orthogonal Axis:	X
Test Mode:	UNII-1/ TX A Mode 5200MHz

Horizontal

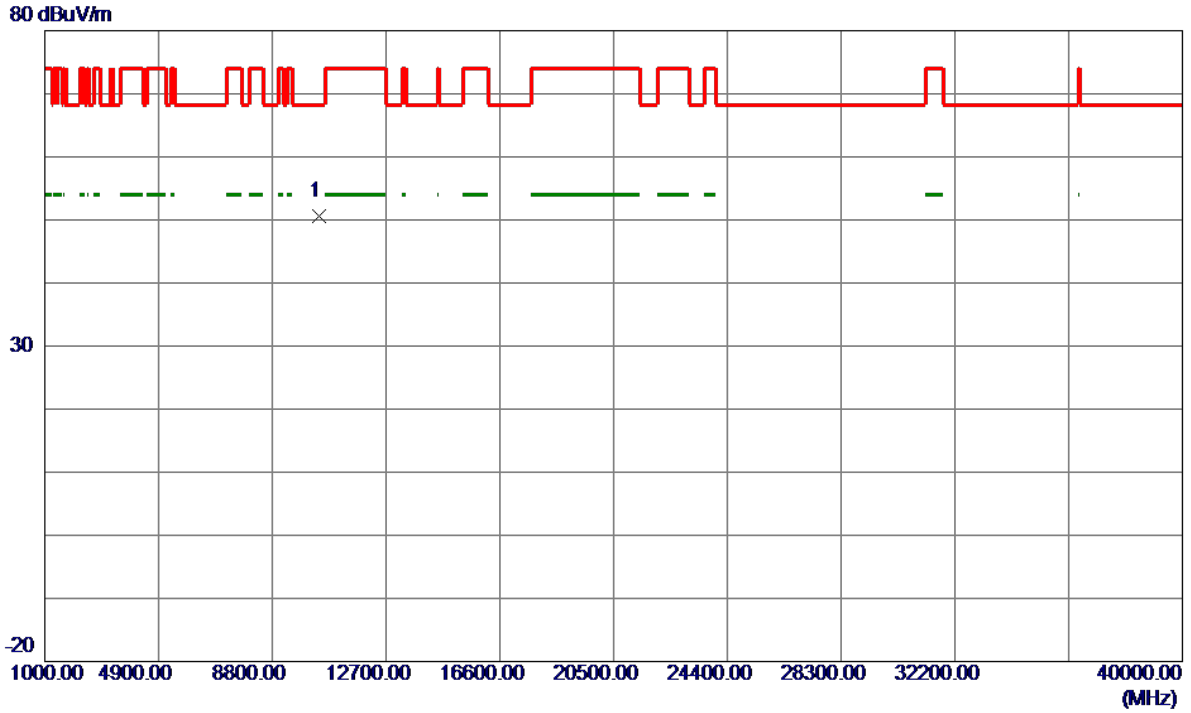

No.	Freq. MHz	Reading Level dBuV/m	Correct Factor dB	Measure ment dBuV/m	Limit dBuV/m	Margin dB	Detector	Comment
1 *	10401.7600	35.64	14.92	50.56	68.30	-17.74	Peak	

Orthogonal Axis:	X
Test Mode:	UNII-1/ TX A Mode 5240MHz

Vertical

130 dBuV/m

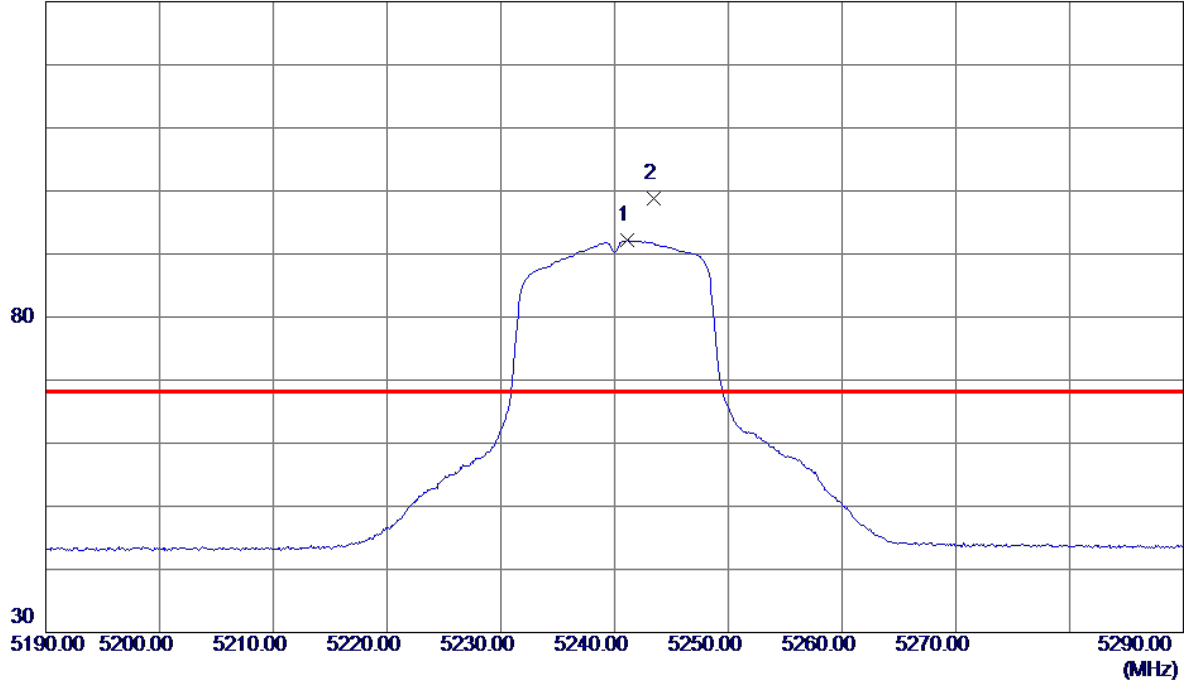

No.	Freq. MHz	Reading Level dBuV/m	Correct Factor dB	Measure ment dBuV/m	Limit dBuV/m	Margin dB	Detector	Comment
1	5241.1000	75.30	16.90	92.20	999.00	-906.80	AVG	No Limit
2 *	5243.4000	81.86	16.91	98.77	68.30	30.47	Peak	No Limit

Orthogonal Axis:	X
Test Mode:	UNII-1/ TX A Mode 5240MHz

Vertical

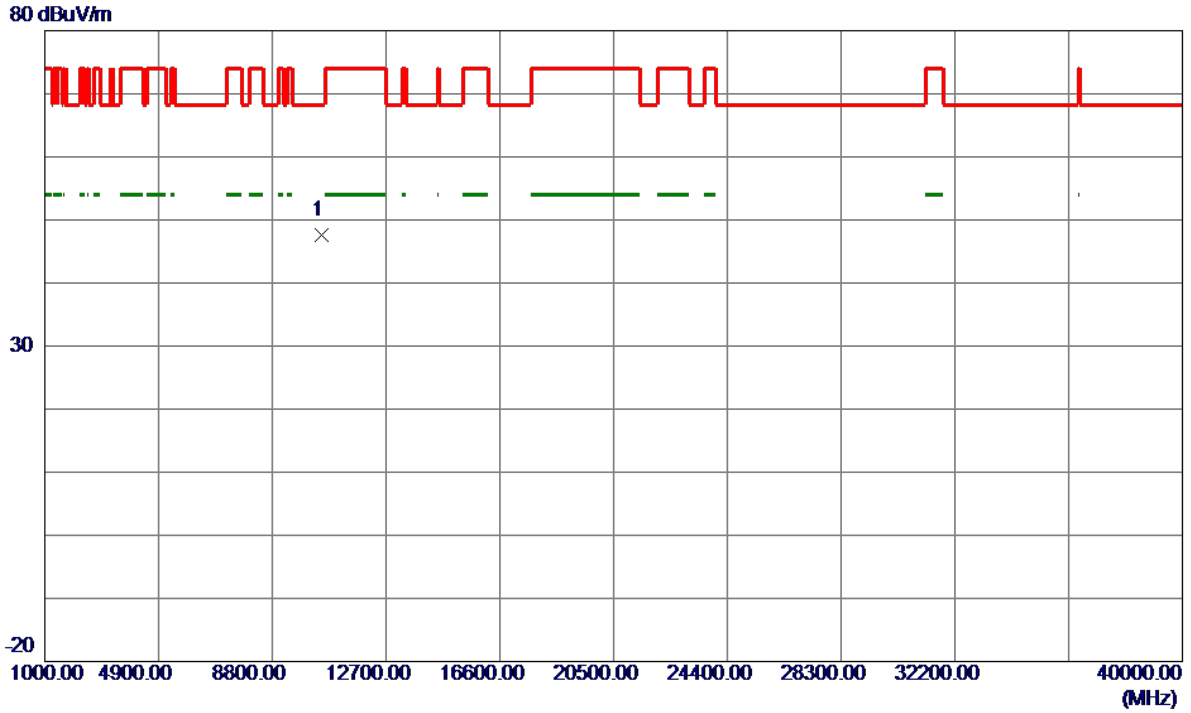

No.	Freq. MHz	Reading Level dBuV/m	Correct Factor dB	Measure ment dBuV/m	Limit dBuV/m	Margin dB	Detector	Comment
1 *	10480.2150	32.56	15.06	47.62	68.30	-20.68	Peak	

Orthogonal Axis:	X
Test Mode:	UNII-1/ TX A Mode 5240MHz

Horizontal

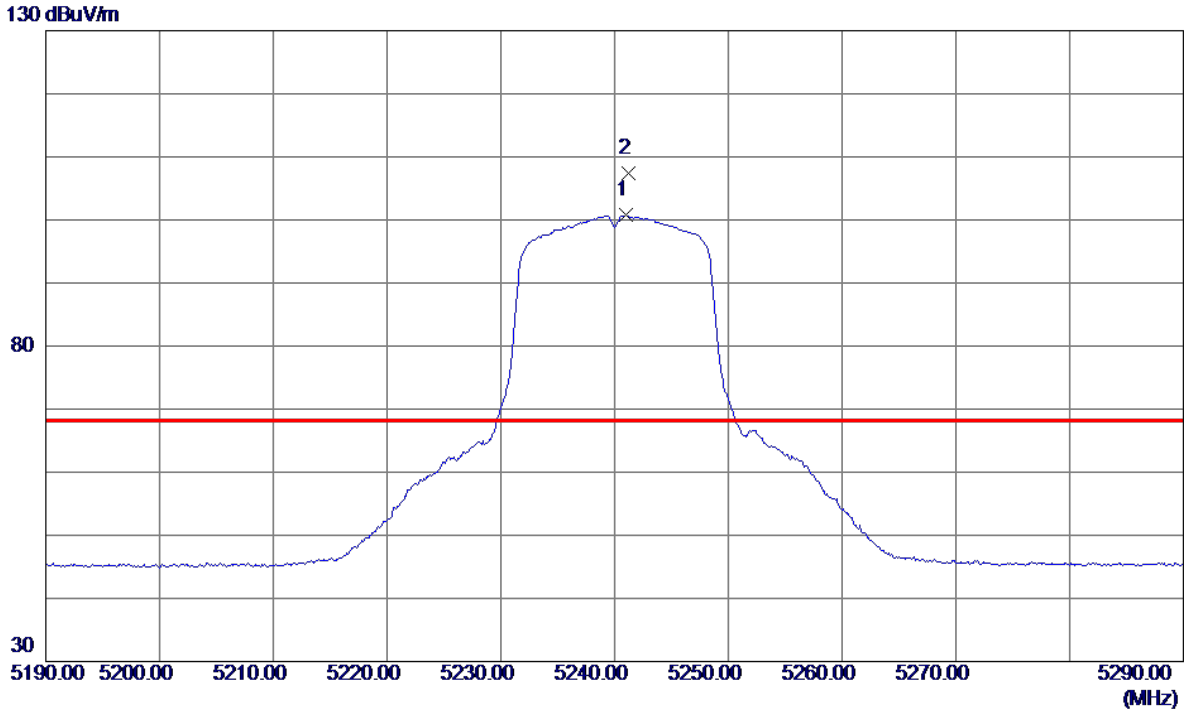

No.	Freq. MHz	Reading Level dBuV/m	Correct Factor dB	Measure ment dBuV/m	Limit dBuV/m	Margin dB	Detector	Comment
1	5241.0000	83.82	16.90	100.72	999.00	-898.28	AVG	No Limit
2 *	5241.2000	90.50	16.90	107.40	68.30	39.10	Peak	No Limit

Orthogonal Axis:	X
Test Mode:	UNII-1/ TX A Mode 5240MHz

Horizontal

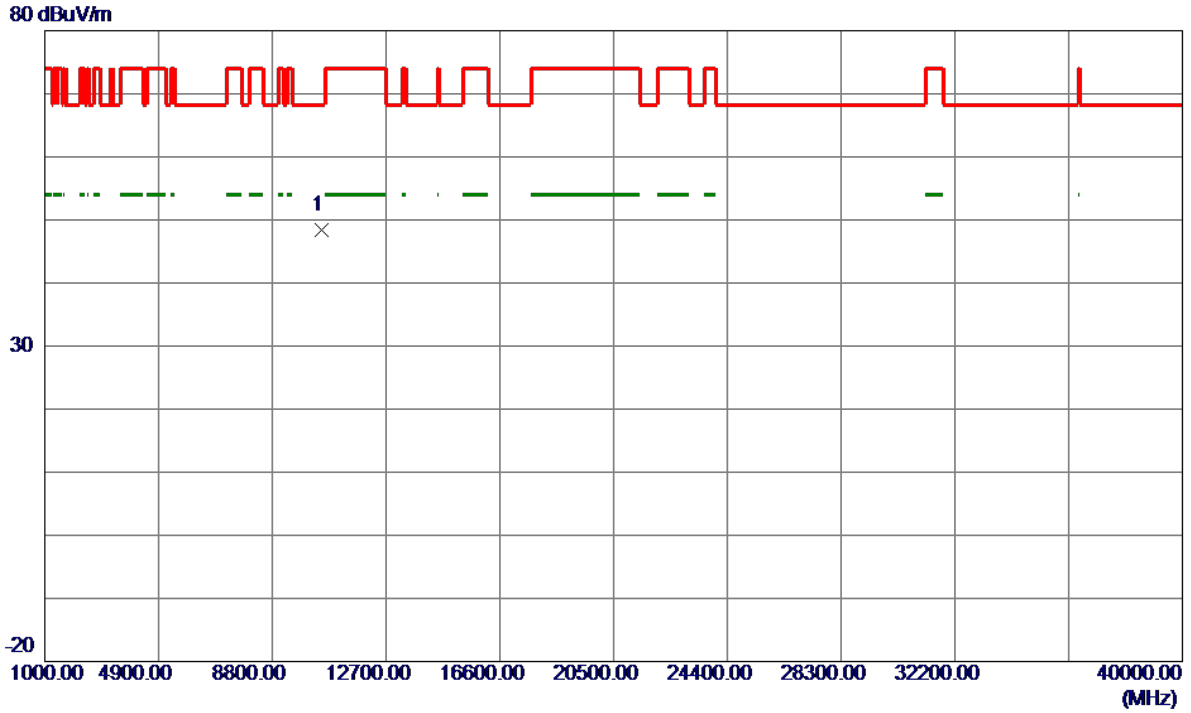

No.	Freq. MHz	Reading Level dBuV/m	Correct Factor dB	Measure ment dBuV/m	Limit dBuV/m	Margin dB	Detector	Comment
1 *	10481.7850	33.31	15.06	48.37	68.30	-19.93	Peak	

Orthogonal Axis:	X
Test Mode:	UNII-1/ TX N20 Mode 5180MHz

Vertical

130 dBuV/m

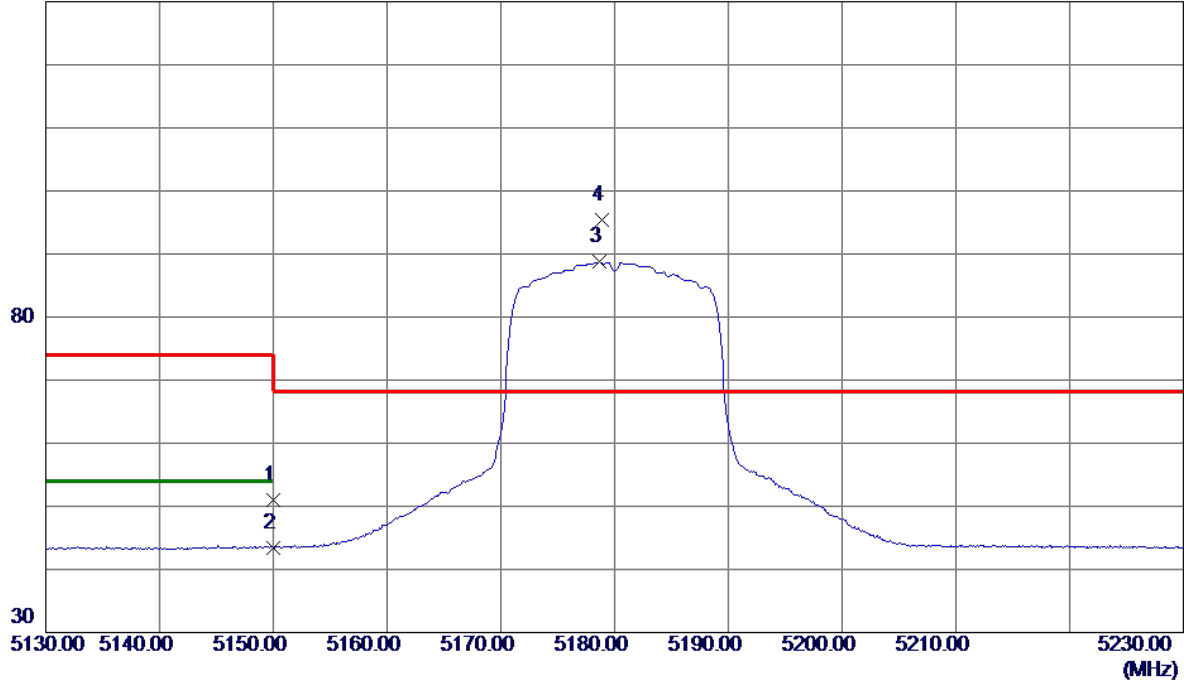

No.	Freq. MHz	Reading Level dBuV/m	Correct Factor dB	Measure ment dBuV/m	Limit dBuV/m	Margin dB	Detector	Comment
1	5150.0000	34.32	16.65	50.97	74.00	-23.03	Peak	
2	5150.0000	26.78	16.65	43.43	54.00	-10.57	AVG	
3	5178.7000	71.98	16.73	88.71	999.00	-910.29	AVG	No Limit
4 *	5178.9000	78.73	16.73	95.46	68.30	27.16	Peak	No Limit

Orthogonal Axis:	X
Test Mode:	UNII-1/ TX N20 Mode 5180MHz

Vertical

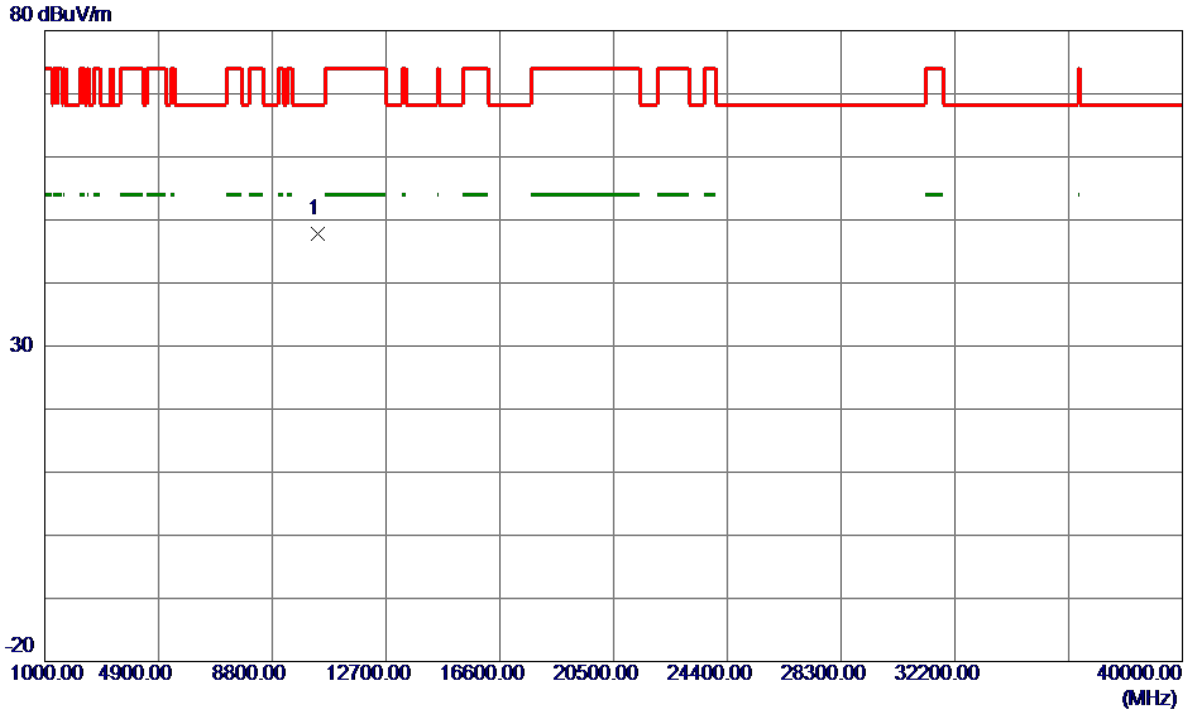

No.	Freq. MHz	Reading Level dBuV/m	Correct Factor dB	Measure ment dBuV/m	Limit dBuV/m	Margin dB	Detector	Comment
1 *	10357.5000	32.96	14.84	47.80	68.30	-20.50	Peak	

Orthogonal Axis:	X
Test Mode:	UNII-1/ TX N20 Mode 5180MHz

Horizontal

130 dBuV/m

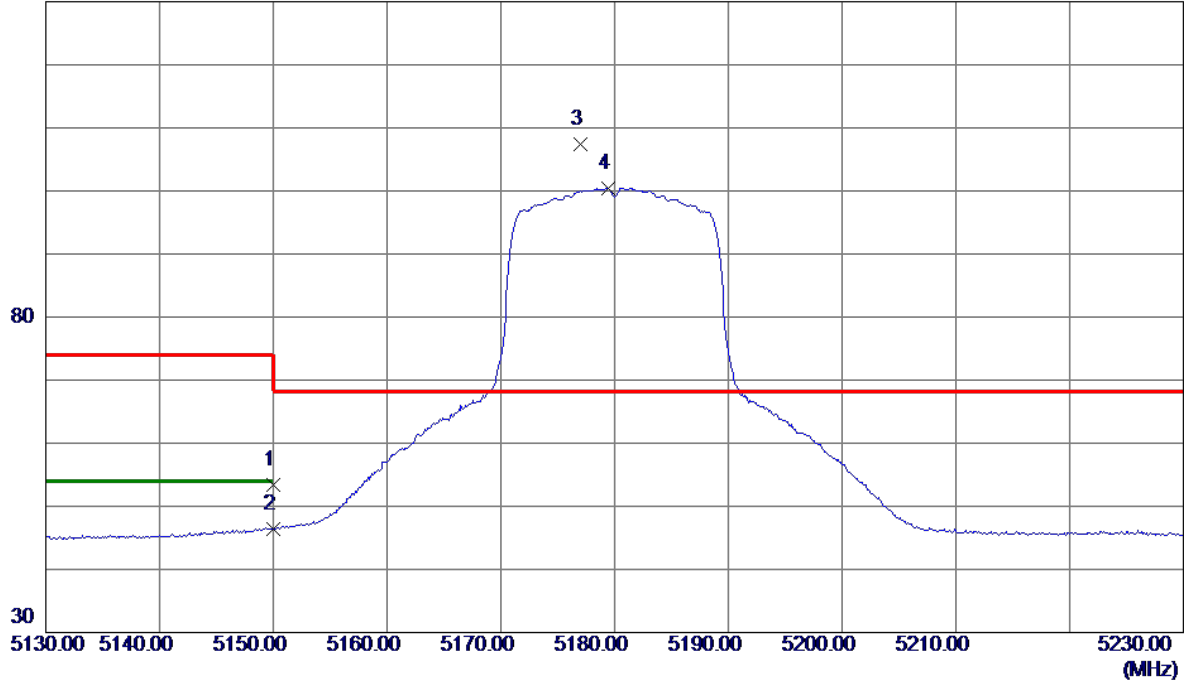

No.	Freq. MHz	Reading Level dBuV/m	Correct Factor dB	Measure ment dBuV/m	Limit dBuV/m	Margin dB	Detector	Comment
1	5150.0000	36.69	16.65	53.34	74.00	-20.66	Peak	
2	5150.0000	29.70	16.65	46.35	54.00	-7.65	AVG	
3 *	5177.0000	90.74	16.72	107.46	68.30	39.16	Peak	No Limit
4	5179.4000	83.69	16.73	100.42	999.00	-898.58	AVG	No Limit

Orthogonal Axis:	X
Test Mode:	UNII-1/ TX N20 Mode 5180MHz

Horizontal

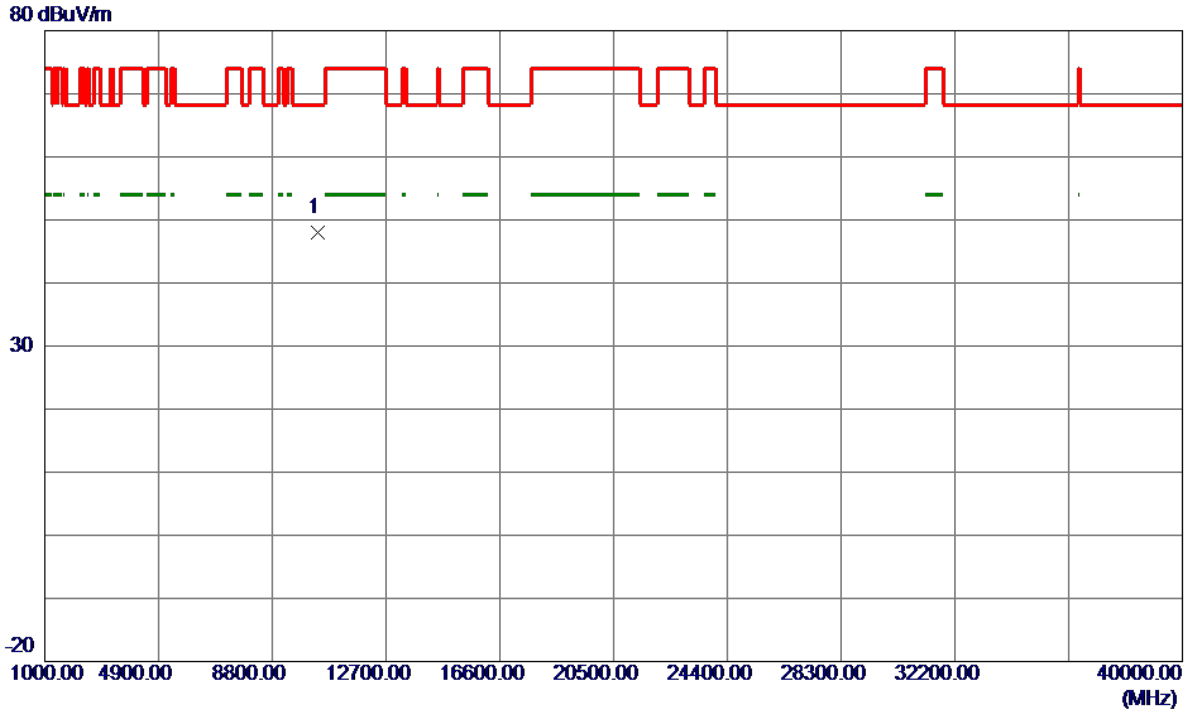

No.	Freq. MHz	Reading Level dBuV/m	Correct Factor dB	Measure ment dBuV/m	Limit dBuV/m	Margin dB	Detector	Comment
1 *	10359.4450	33.20	14.85	48.05	68.30	-20.25	Peak	

Orthogonal Axis:	X
Test Mode:	UNII-1/ TX N20 Mode 5200MHz

Vertical

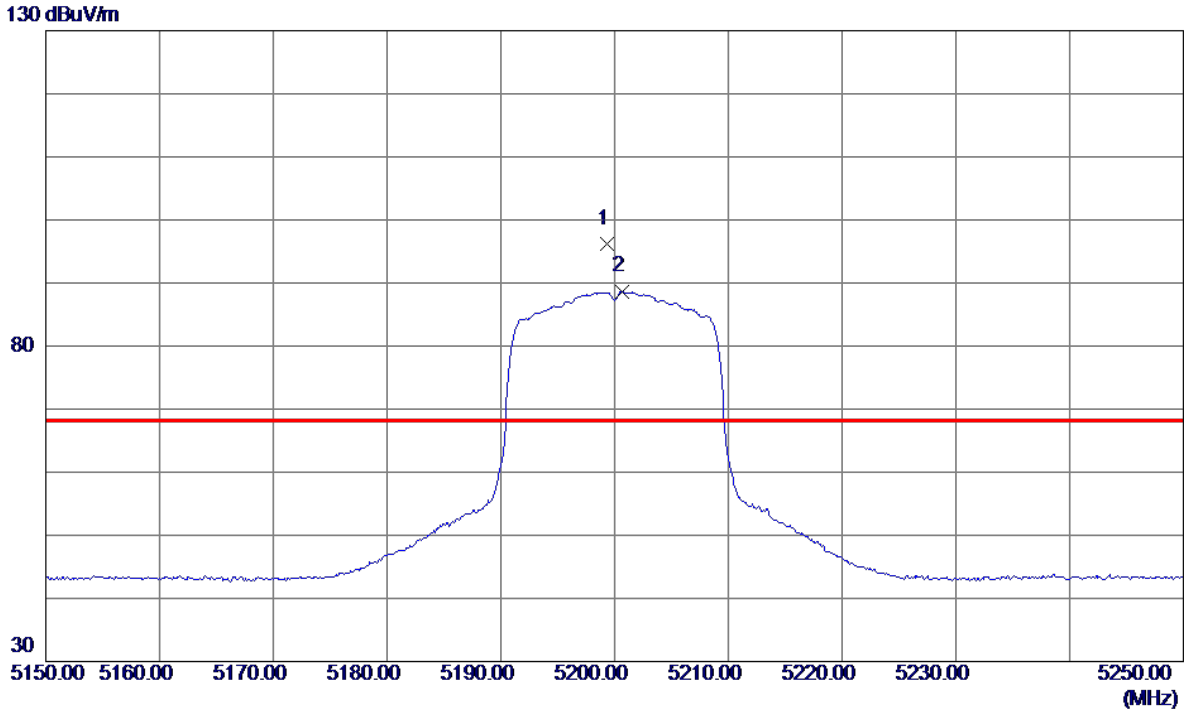

No.	Freq. MHz	Reading Level dBuV/m	Correct Factor dB	Measure ment dBuV/m	Limit dBuV/m	Margin dB	Detector	Comment
1 *	5199.3000	79.39	16.79	96.18	68.30	27.88	Peak	No Limit
2	5200.7000	71.91	16.79	88.70	999.00	-910.30	AVG	No Limit

Orthogonal Axis:	X
Test Mode:	UNII-1/ TX N20 Mode 5200MHz

Vertical

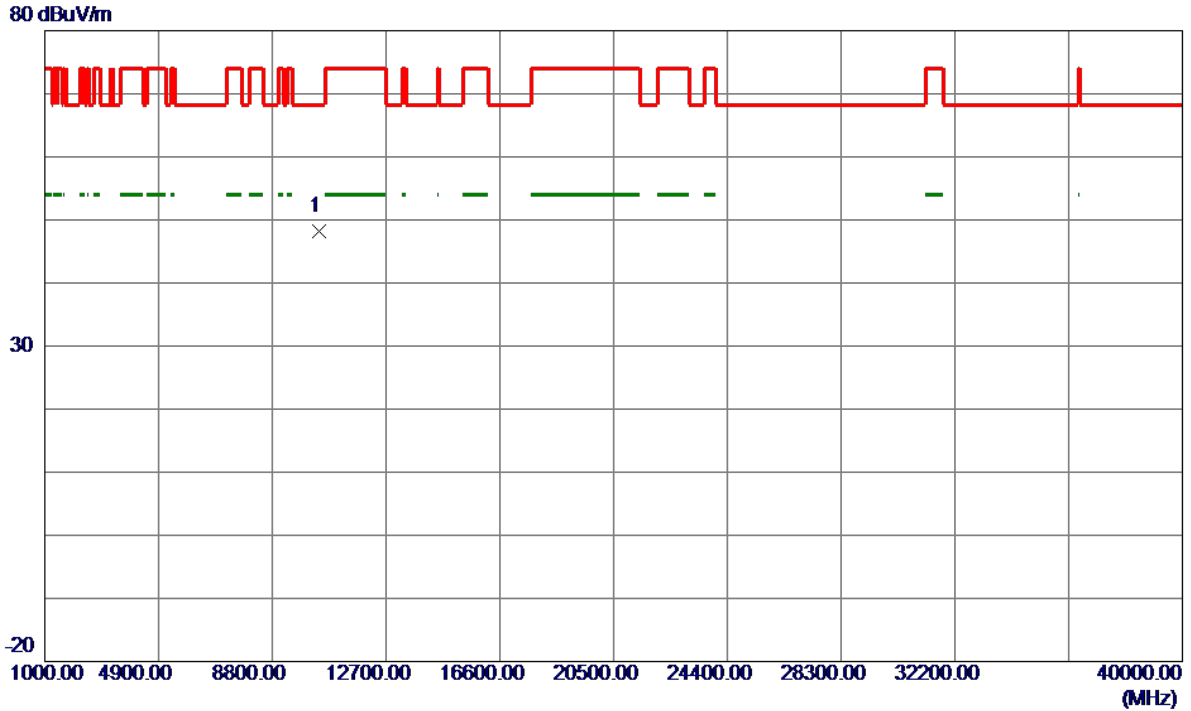

No.	Freq. MHz	Reading Level dBuV/m	Correct Factor dB	Measure ment dBuV/m	Limit dBuV/m	Margin dB	Detector	Comment
1 *	10402.4000	33.31	14.92	48.23	68.30	-20.07	Peak	

Orthogonal Axis:	X
Test Mode:	UNII-1/ TX N20 Mode 5200MHz

Horizontal

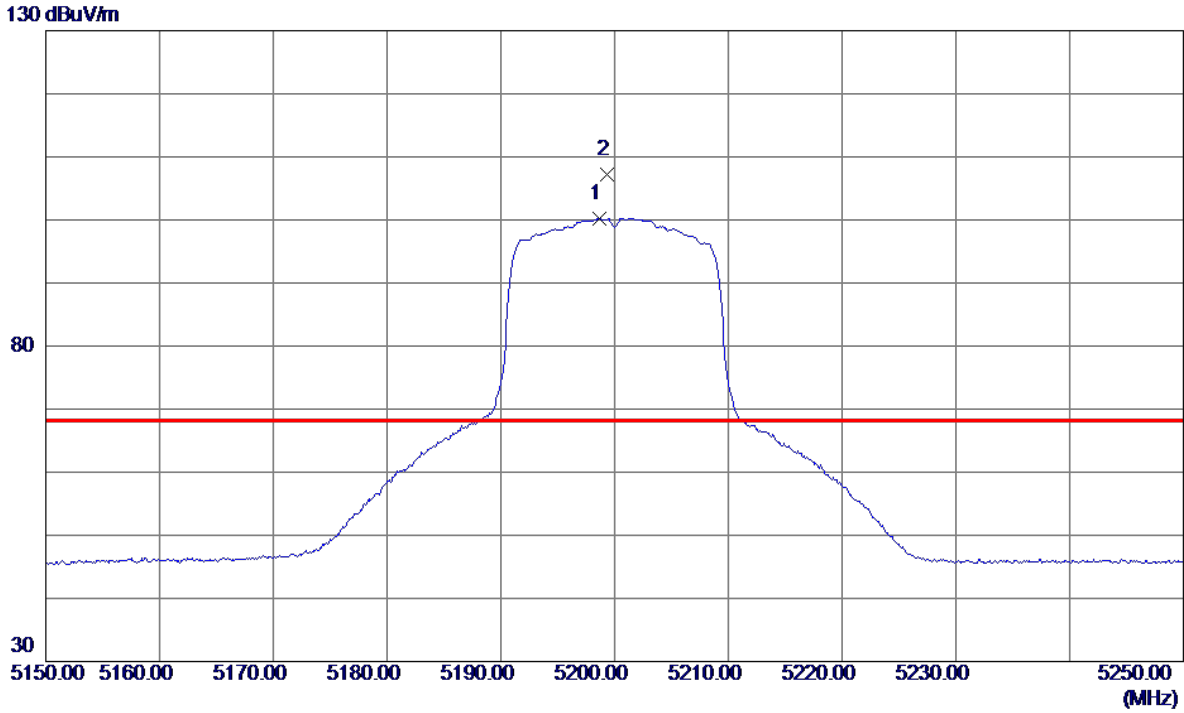

No.	Freq. MHz	Reading Level dBuV/m	Correct Factor dB	Measure ment dBuV/m	Limit dBuV/m	Margin dB	Detector	Comment
1	5198.7000	83.47	16.78	100.25	999.00	-898.75	AVG	No Limit
2 *	5199.3000	90.34	16.79	107.13	68.30	38.83	Peak	No Limit

Orthogonal Axis:	X
Test Mode:	UNII-1/ TX N20 Mode 5200MHz

Horizontal



No.	Freq. MHz	Reading Level dBuV/m	Correct Factor dB	Measure ment dBuV/m	Limit dBuV/m	Margin dB	Detector	Comment
1 *	10399.5950	33.26	14.92	48.18	68.30	-20.12	Peak	

Orthogonal Axis:	X
Test Mode:	UNII-1/ TX N20 Mode 5240MHz

Vertical

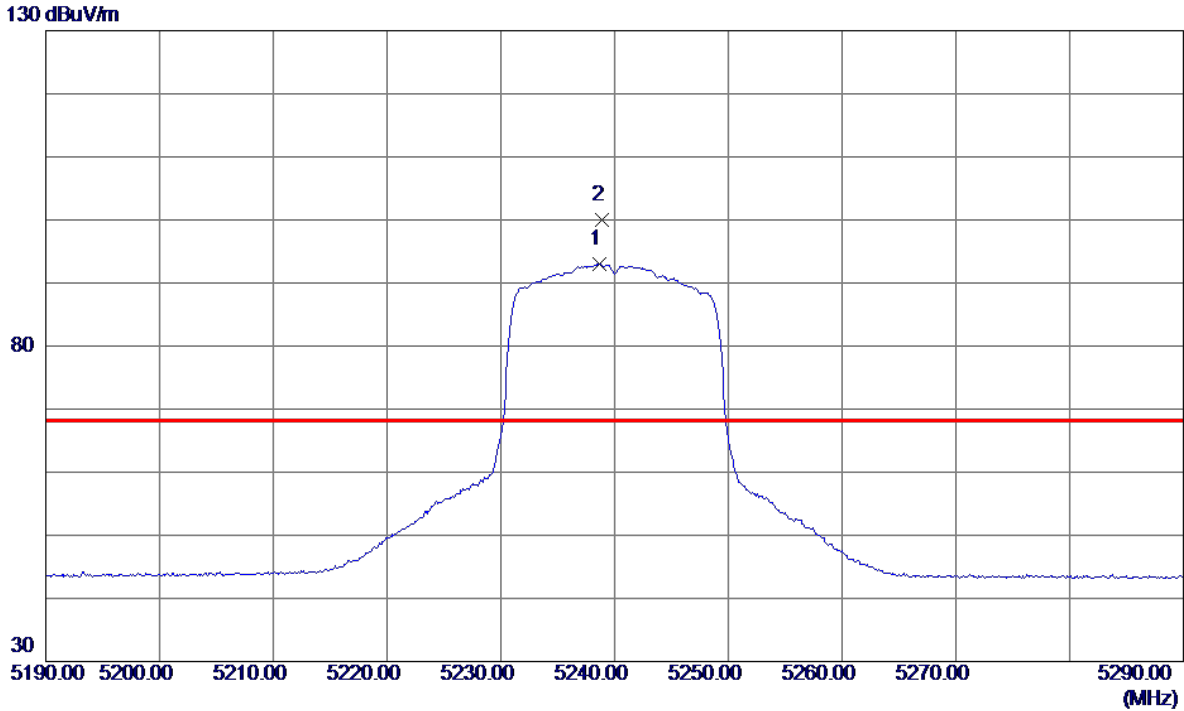

No.	Freq. MHz	Reading Level dBuV/m	Correct Factor dB	Measure ment dBuV/m	Limit dBuV/m	Margin dB	Detector	Comment
1	5238.7000	76.14	16.90	93.04	999.00	-905.96	AVG	No Limit
2 *	5238.9000	83.07	16.90	99.97	68.30	31.67	Peak	No Limit

Orthogonal Axis:	X
Test Mode:	UNII-1/ TX N20 Mode 5240MHz

Vertical



No.	Freq. MHz	Reading Level dBuV/m	Correct Factor dB	Measure ment dBuV/m	Limit dBuV/m	Margin dB	Detector	Comment
1	10477.6250	33.21	15.06	48.27	999.00	-950.73	AVG	

Orthogonal Axis:	X
Test Mode:	UNII-1/ TX N20 Mode 5240MHz

Horizontal

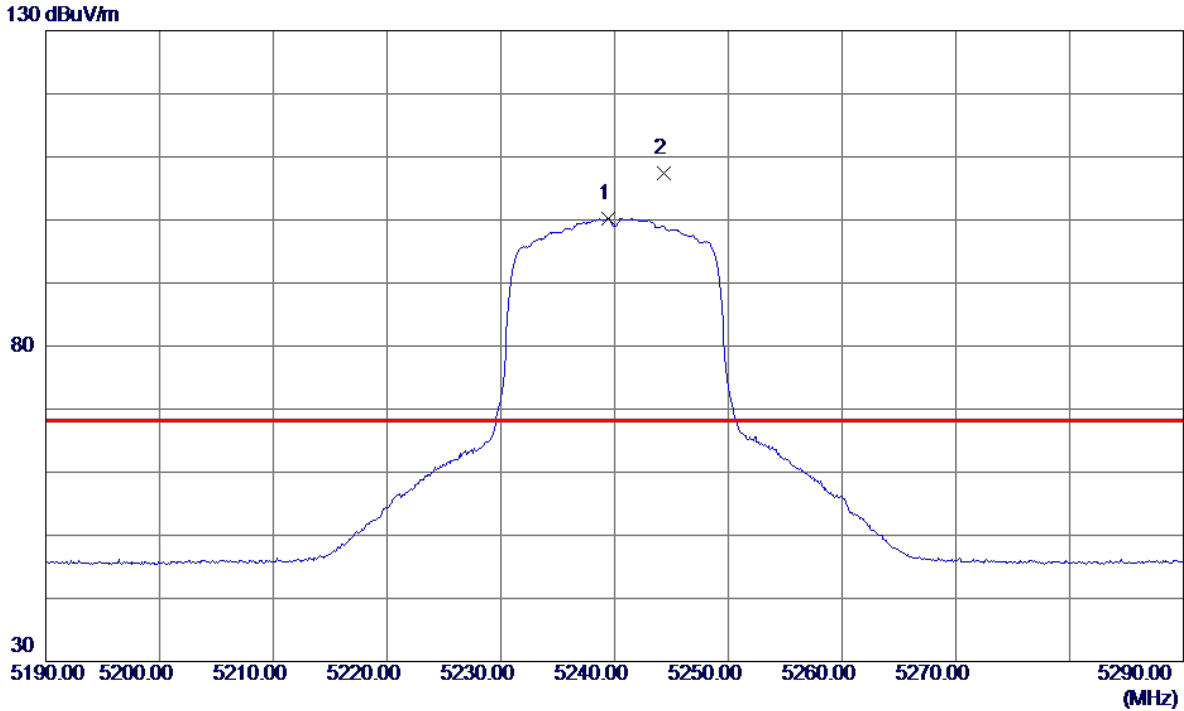

No.	Freq. MHz	Reading Level dBuV/m	Correct Factor dB	Measure ment dBuV/m	Limit dBuV/m	Margin dB	Detector	Comment
1	5239.4000	83.34	16.90	100.24	999.00	-898.76	AVG	No Limit
2 *	5244.3000	90.54	16.91	107.45	68.30	39.15	Peak	No Limit

Orthogonal Axis:	X
Test Mode:	UNII-1/ TX N20 Mode 5240MHz

Horizontal

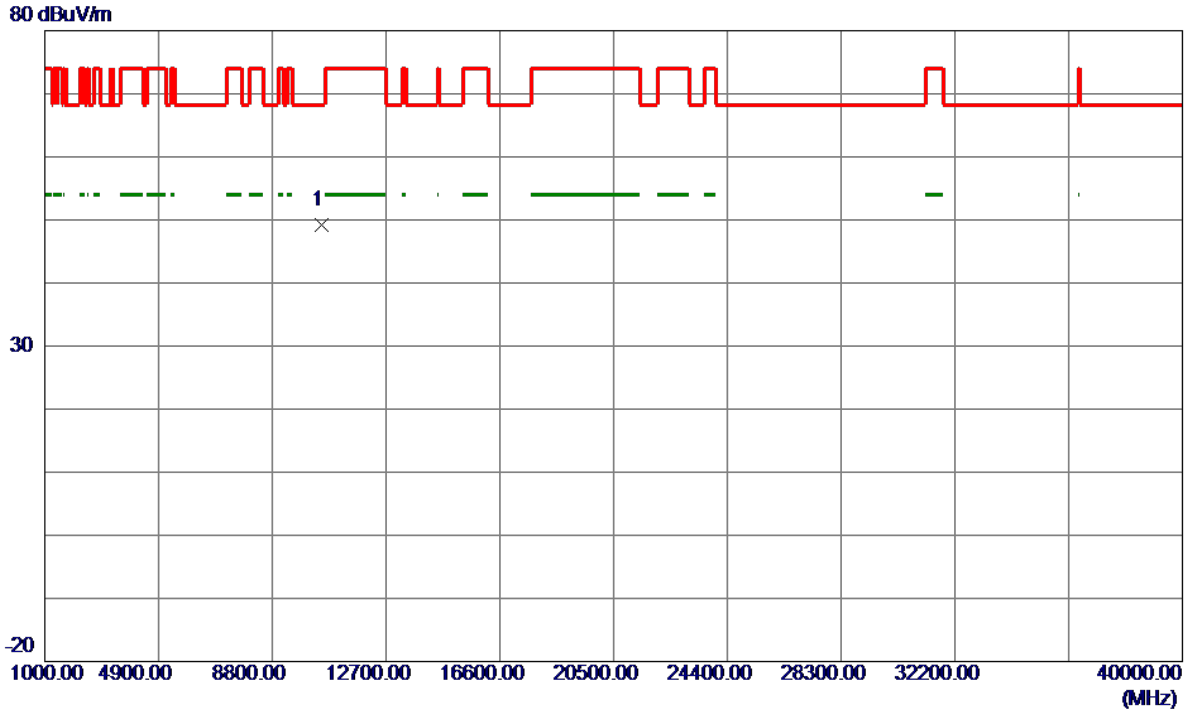

No.	Freq. MHz	Reading Level dBuV/m	Correct Factor dB	Measure ment dBuV/m	Limit dBuV/m	Margin dB	Detector	Comment
1 *	10480.8350	34.20	15.06	49.26	68.30	-19.04	Peak	

Orthogonal Axis:	X
Test Mode:	UNII-1/ TX N40 Mode 5190MHz

Vertical

130 dBuV/m

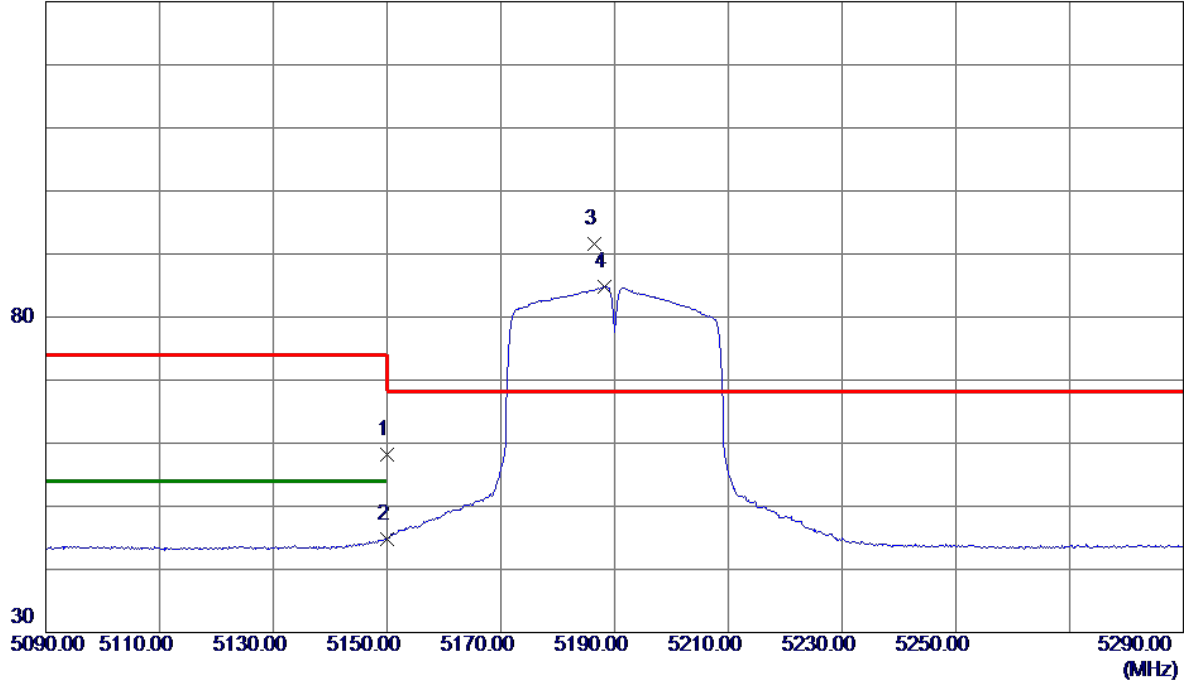

No.	Freq. MHz	Reading Level dBuV/m	Correct Factor dB	Measure ment dBuV/m	Limit dBuV/m	Margin dB	Detector	Comment
1	5150.0000	41.49	16.65	58.14	74.00	-15.86	Peak	
2	5150.0000	28.19	16.65	44.84	54.00	-9.16	AVG	
3 *	5186.4000	74.92	16.75	91.67	68.30	23.37	Peak	No Limit
4	5188.2000	68.02	16.75	84.77	999.00	-914.23	AVG	No Limit

Orthogonal Axis:	X
Test Mode:	UNII-1/ TX N40 Mode 5190MHz

Vertical

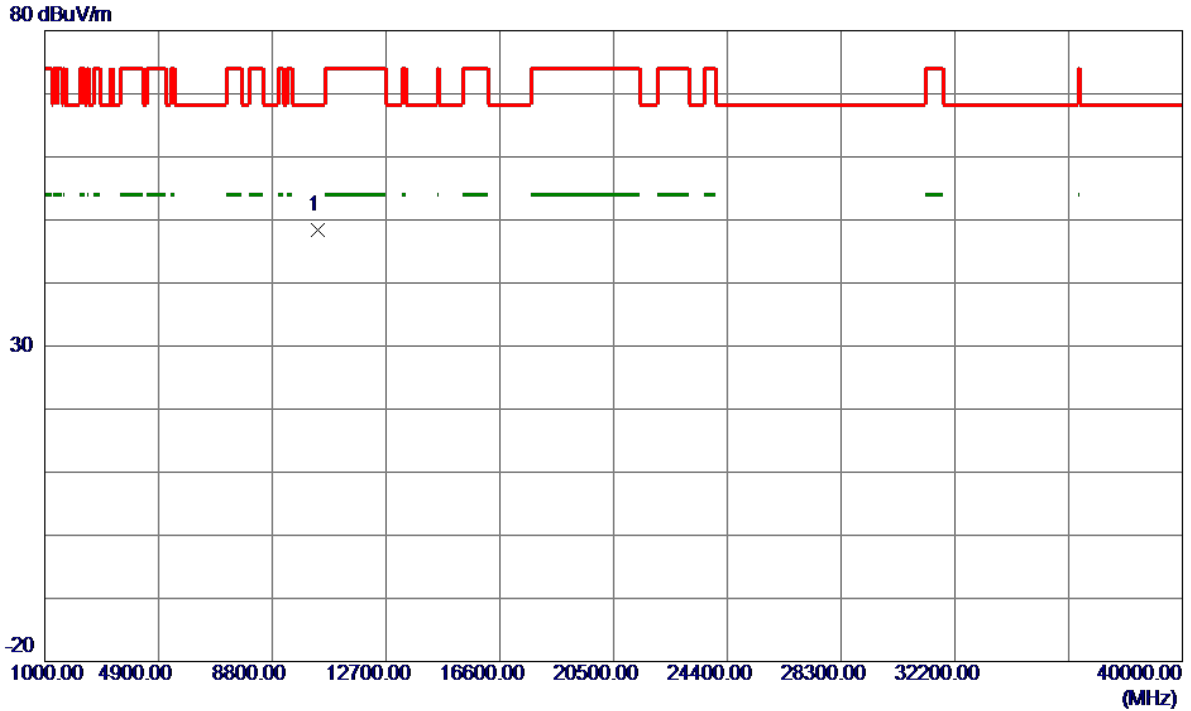

No.	Freq. MHz	Reading Level dBuV/m	Correct Factor dB	Measure ment dBuV/m	Limit dBuV/m	Margin dB	Detector	Comment
1 *	10381.0300	33.52	14.88	48.40	68.30	-19.90	Peak	

Orthogonal Axis:	X
Test Mode:	UNII-1/ TX N40 Mode 5190MHz

Horizontal

130 dBuV/m

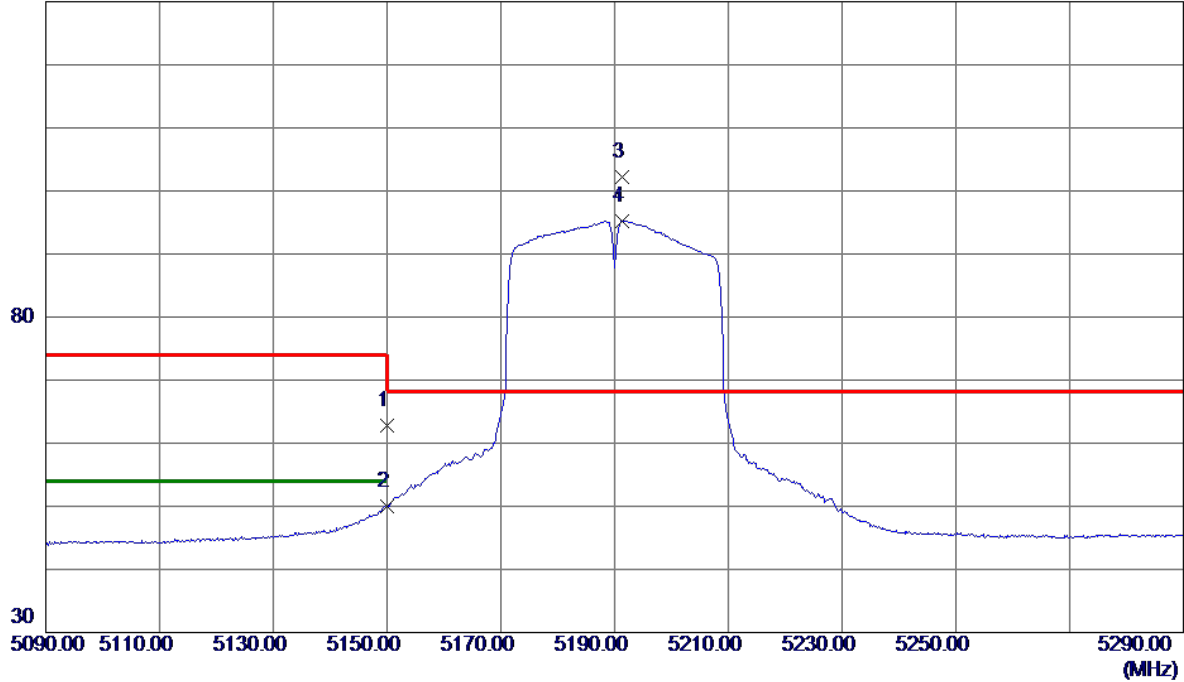

No.	Freq. MHz	Reading Level dBuV/m	Correct Factor dB	Measure ment dBuV/m	Limit dBuV/m	Margin dB	Detector	Comment
1	5150.0000	46.21	16.65	62.86	74.00	-11.14	Peak	
2	5150.0000	33.39	16.65	50.04	54.00	-3.96	AVG	
3 *	5191.4000	85.43	16.76	102.19	68.30	33.89	Peak	No Limit
4	5191.4000	78.46	16.76	95.22	999.00	-903.78	AVG	No Limit

Orthogonal Axis:	X
Test Mode:	UNII-1/ TX N40 Mode 5190MHz

Horizontal

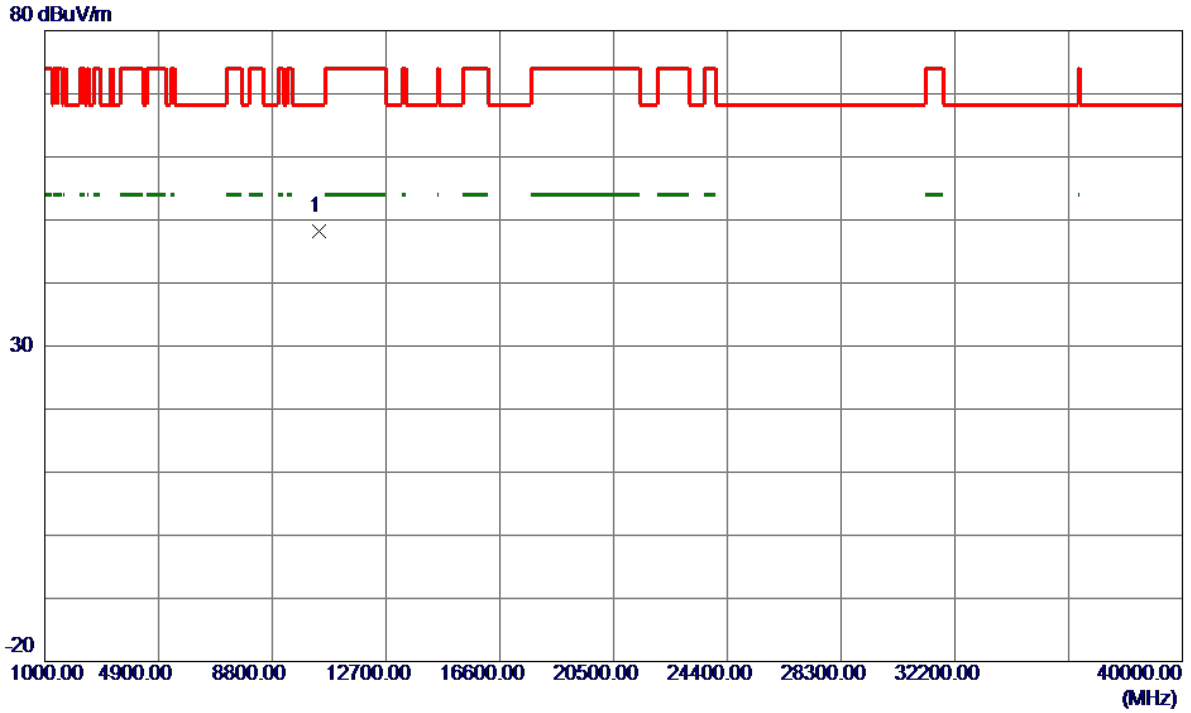

No.	Freq. MHz	Reading Level dBuV/m	Correct Factor dB	Measure ment dBuV/m	Limit dBuV/m	Margin dB	Detector	Comment
1 *	10381.8350	33.32	14.89	48.21	68.30	-20.09	Peak	

Orthogonal Axis:	X
Test Mode:	UNII-1/ TX N40 Mode 5230MHz

Vertical

130 dBuV/m

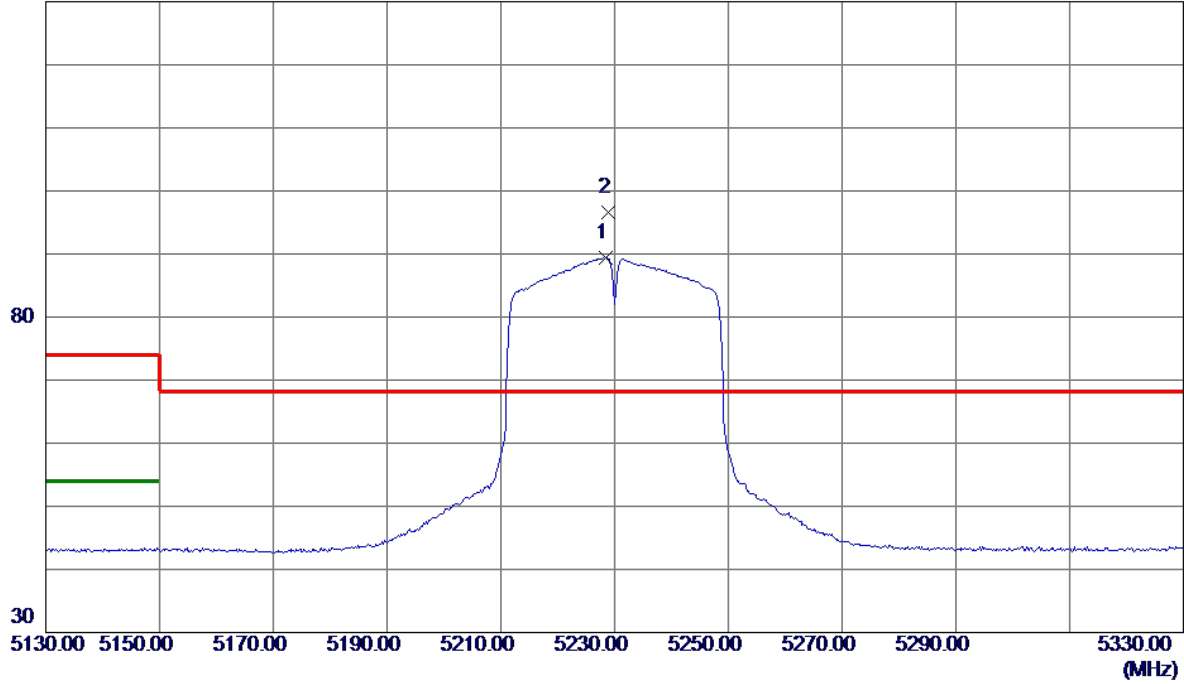

No.	Freq. MHz	Reading Level dBuV/m	Correct Factor dB	Measure ment dBuV/m	Limit dBuV/m	Margin dB	Detector	Comment
1	5228.4000	72.56	16.87	89.43	999.00	-909.57	AVG	No Limit
2 *	5228.8000	79.75	16.87	96.62	68.30	28.32	Peak	No Limit

Orthogonal Axis:	X
Test Mode:	UNII-1/ TX N40 Mode 5230MHz

Vertical

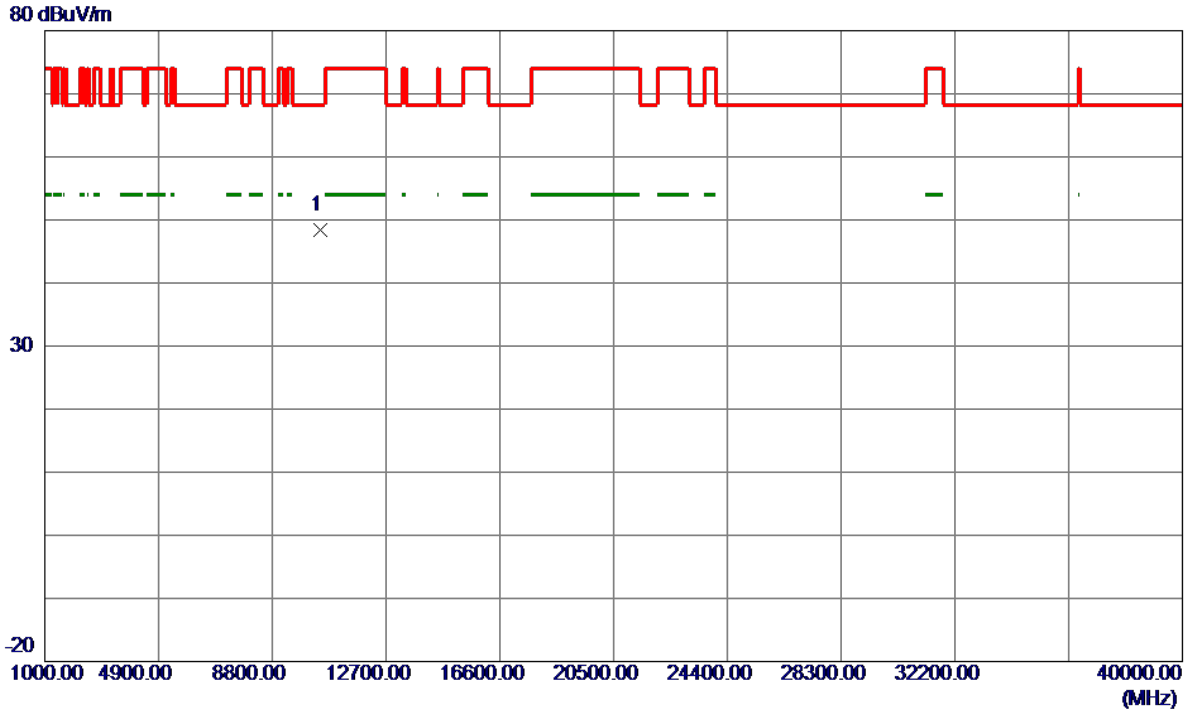

No.	Freq. MHz	Reading Level dBuV/m	Correct Factor dB	Measure ment dBuV/m	Limit dBuV/m	Margin dB	Detector	Comment
1 *	10458.2850	33.33	15.02	48.35	68.30	-19.95	Peak	

Orthogonal Axis:	X
Test Mode:	UNII-1/ TX N40 Mode 5230MHz

Horizontal

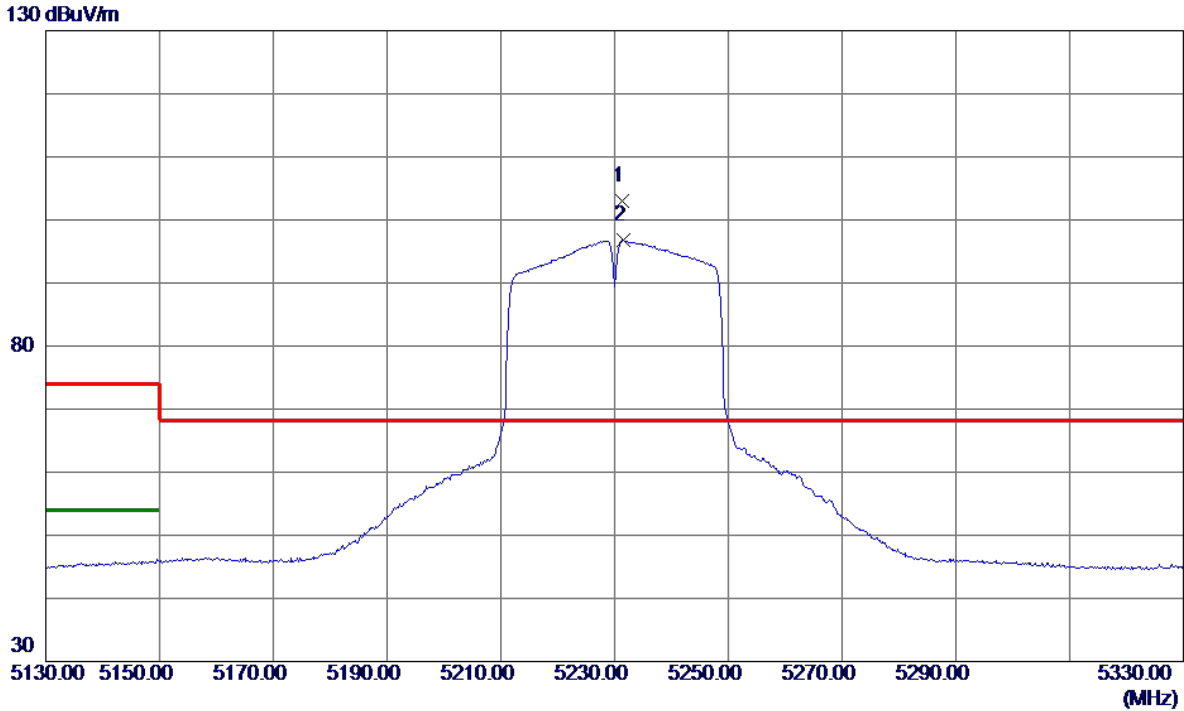

No.	Freq. MHz	Reading Level dBuV/m	Correct Factor dB	Measure ment dBuV/m	Limit dBuV/m	Margin dB	Detector	Comment
1 *	5231.4000	86.09	16.88	102.97	68.30	34.67	Peak	No Limit
2	5231.6000	79.88	16.88	96.76	999.00	-902.24	AVG	No Limit

Orthogonal Axis:	X
Test Mode:	UNII-1/ TX N40 Mode 5230MHz

Horizontal

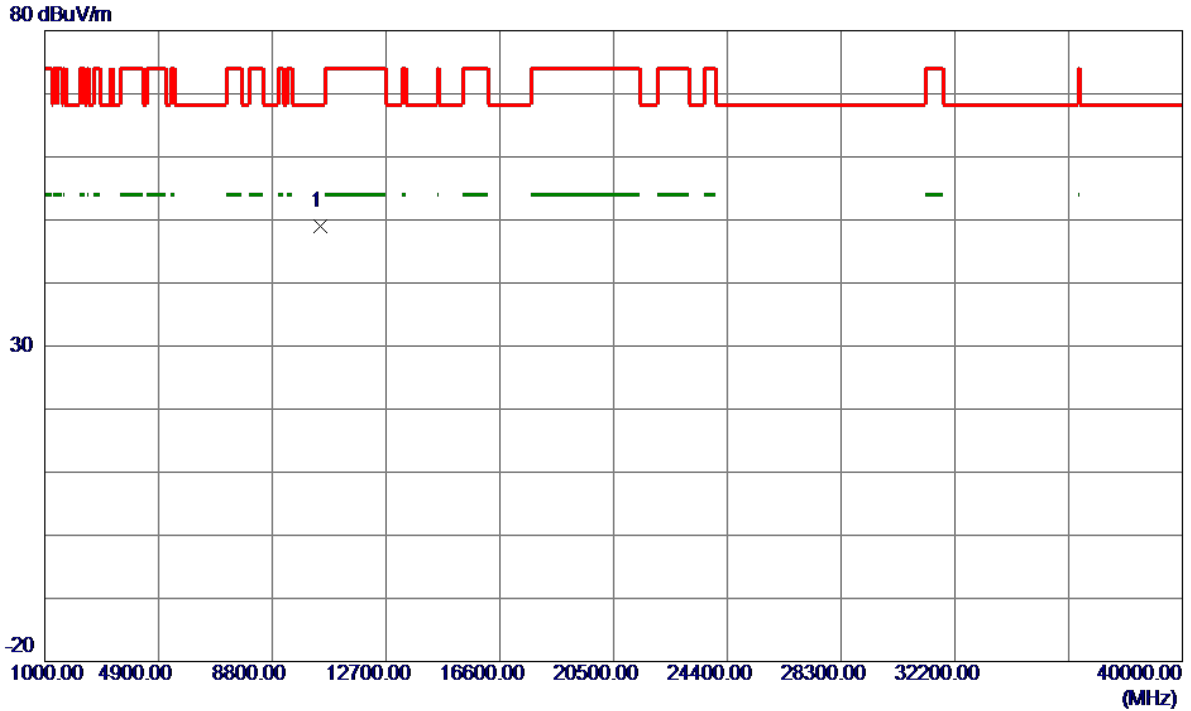

No.	Freq. MHz	Reading Level dBuV/m	Correct Factor dB	Measure ment dBuV/m	Limit dBuV/m	Margin dB	Detector	Comment
1 *	10460.2150	33.98	15.02	49.00	68.30	-19.30	Peak	

Orthogonal Axis :	X
Test Mode :	UNII-2A/ TX A Mode 5260MHz

Vertical

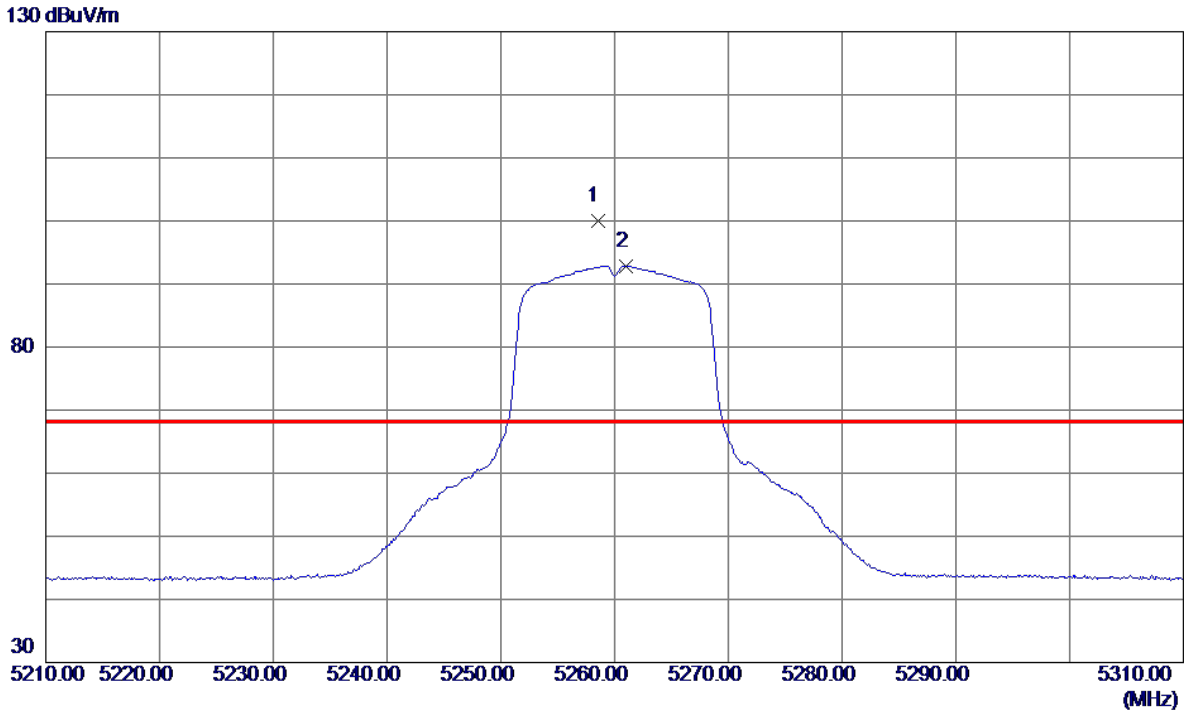

No.	Freq. MHz	Reading Level dBuV/m	Correct Factor dB	Measure ment dBuV/m	Limit dBuV/m	Margin dB	Detector	Comment
1 *	5258.5000	83.06	16.95	100.01	68.30	31.71	Peak	No Limit
2	5261.0000	75.92	16.96	92.88	999.00	-906.12	AVG	No Limit

Orthogonal Axis :	X
Test Mode :	UNII-2A/ TX A Mode 5260MHz

Vertical

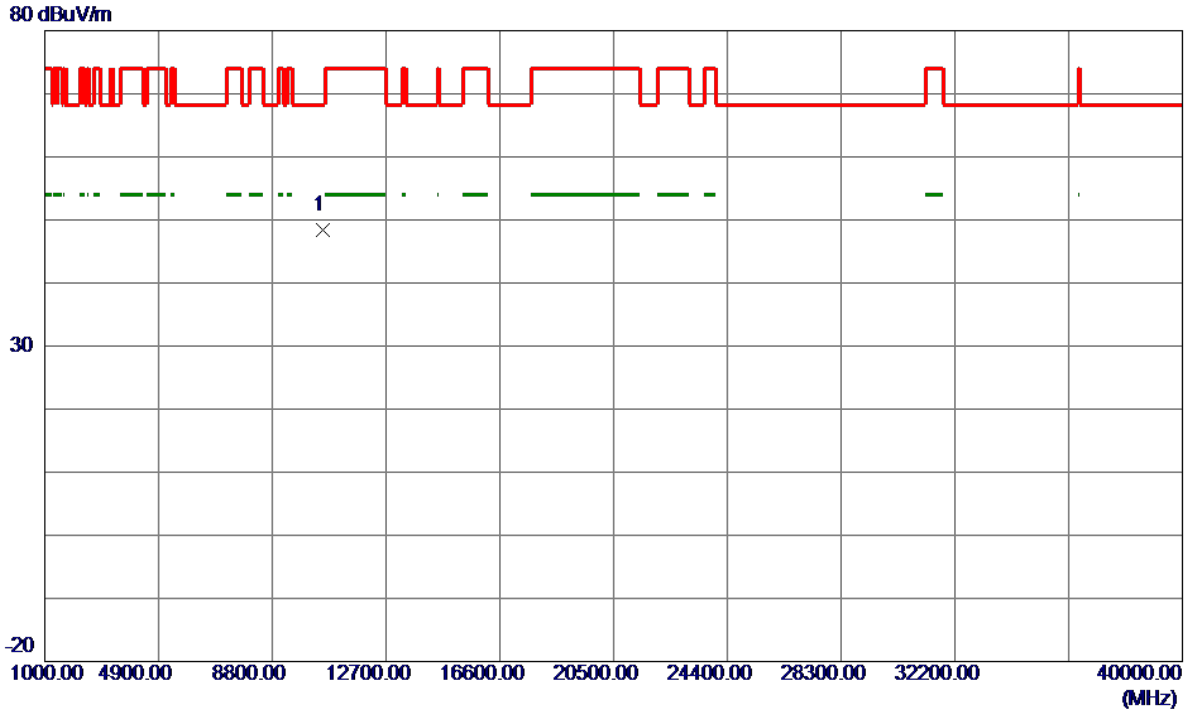

No.	Freq. MHz	Reading Level dBuV/m	Correct Factor dB	Measure ment dBuV/m	Limit dBuV/m	Margin dB	Detector	Comment
1 *	10520.8500	33.25	15.11	48.36	68.30	-19.94	Peak	

Orthogonal Axis :	X
Test Mode :	UNII-2A/ TX A Mode 5260MHz

Horizontal

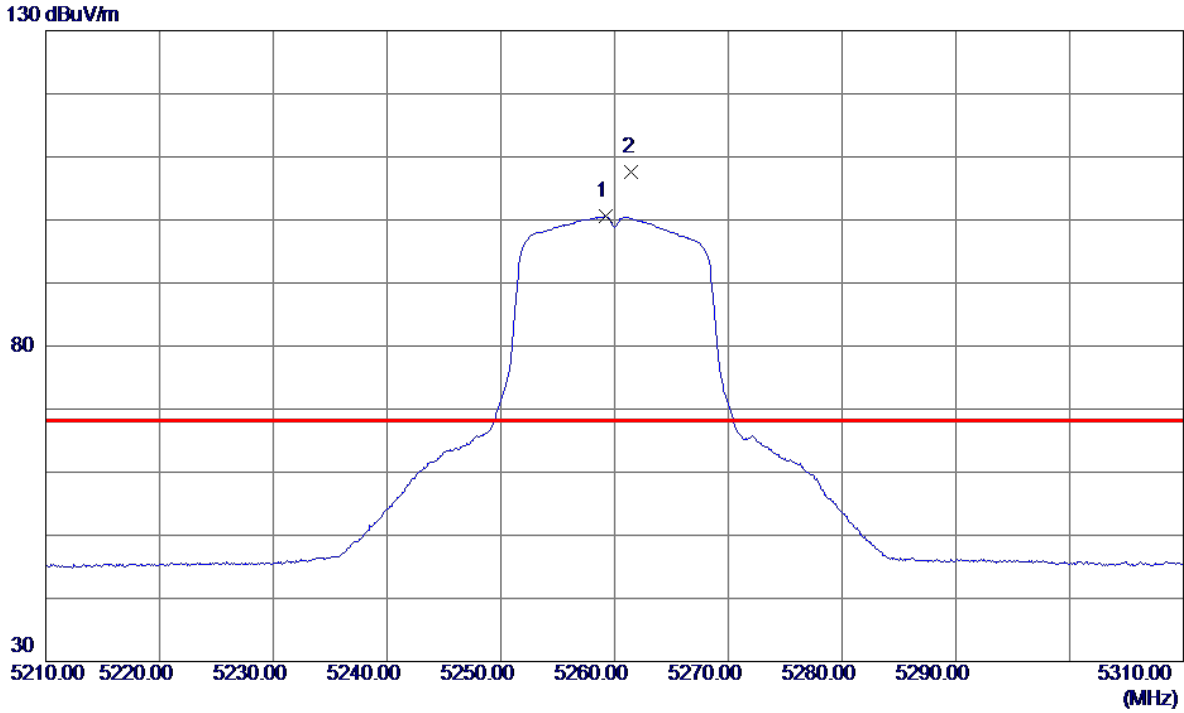

No.	Freq. MHz	Reading Level dBuV/m	Correct Factor dB	Measure ment dBuV/m	Limit dBuV/m	Margin dB	Detector	Comment
1	5259.2000	83.57	16.96	100.53	999.00	-898.47	AVG	No Limit
2 *	5261.5000	90.72	16.96	107.68	68.30	39.38	Peak	No Limit

Orthogonal Axis :	X
Test Mode :	UNII-2A/ TX A Mode 5260MHz

Horizontal

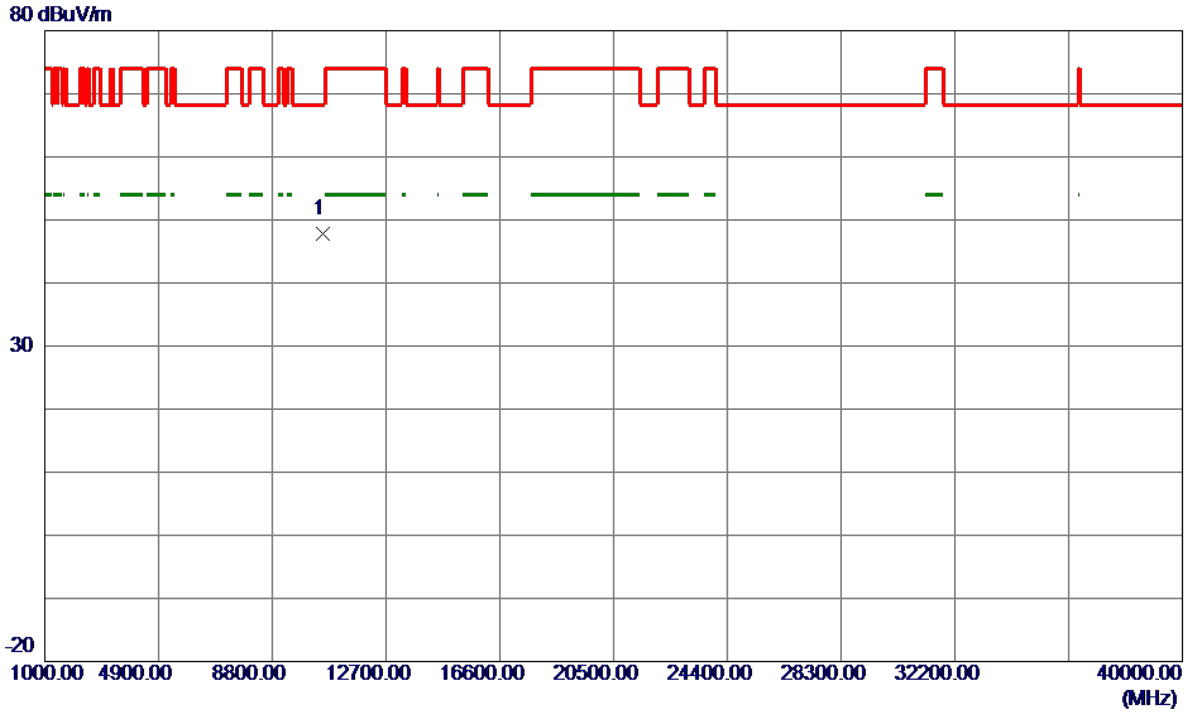

No.	Freq. MHz	Reading Level dBuV/m	Correct Factor dB	Measure ment dBuV/m	Limit dBuV/m	Margin dB	Detector	Comment
1 *	10521.2100	32.71	15.11	47.82	68.30	-20.48	Peak	

Orthogonal Axis :	X
Test Mode :	UNII-2A/ TX A Mode 5300MHz

Vertical

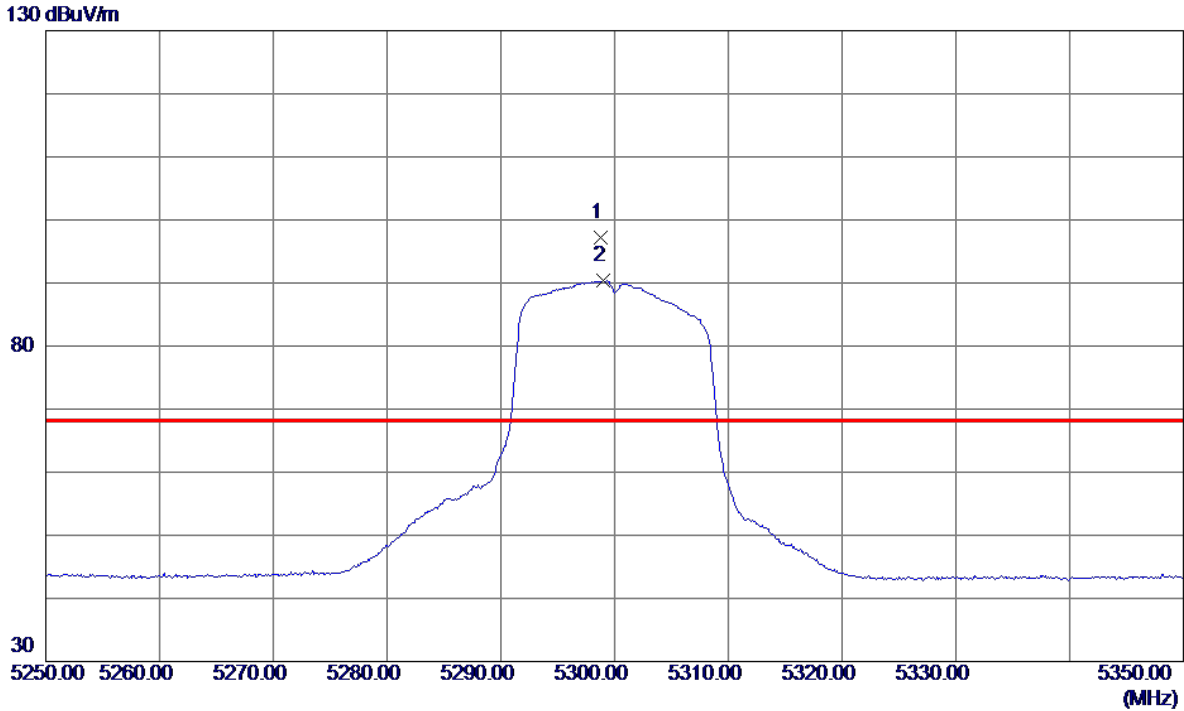

No.	Freq. MHz	Reading Level dBuV/m	Correct Factor dB	Measure ment dBuV/m	Limit dBuV/m	Margin dB	Detector	Comment
1 *	5298.8000	80.15	17.07	97.22	68.30	28.92	Peak	No Limit
2	5299.0000	73.27	17.07	90.34	999.00	-908.66	AVG	No Limit

Orthogonal Axis :	X
Test Mode :	UNII-2A/ TX A Mode 5300MHz

Vertical

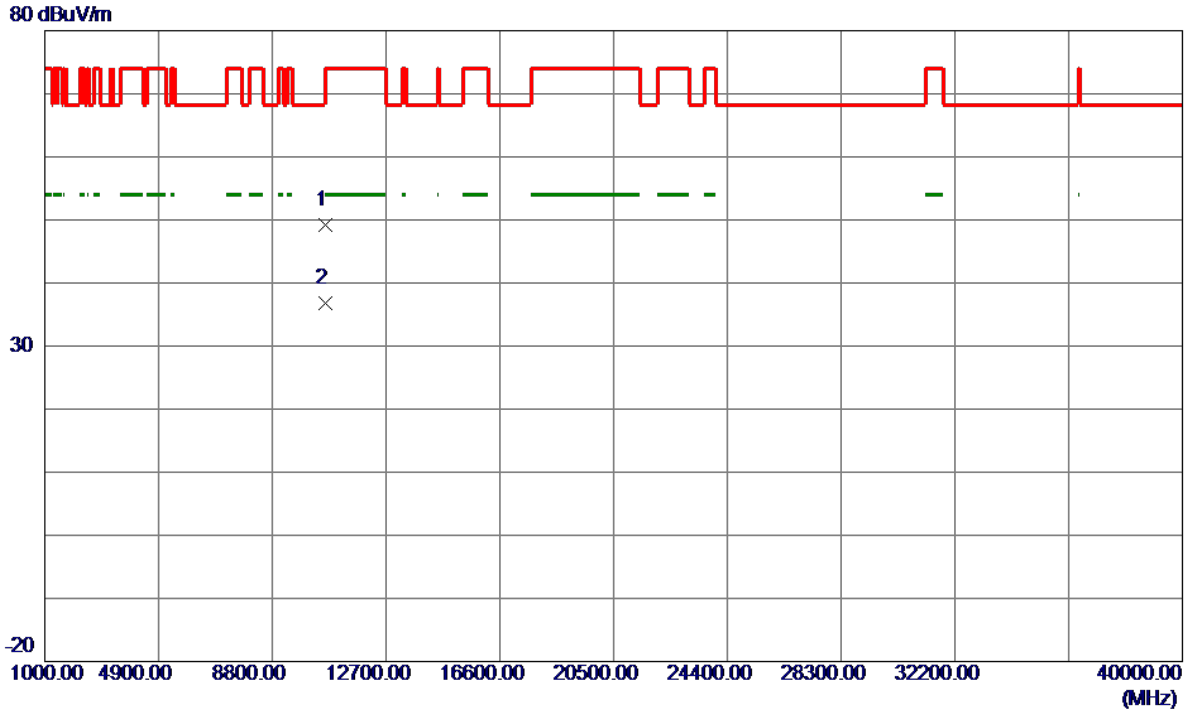

No.	Freq. MHz	Reading Level dBuV/m	Correct Factor dB	Measure ment dBuV/m	Limit dBuV/m	Margin dB	Detector	Comment
1	10600.5800	34.05	15.16	49.21	74.00	-24.79	Peak	
2 *	10600.7000	21.68	15.16	36.84	54.00	-17.16	AVG	

Orthogonal Axis :	X
Test Mode :	UNII-2A/ TX A Mode 5300MHz

Horizontal

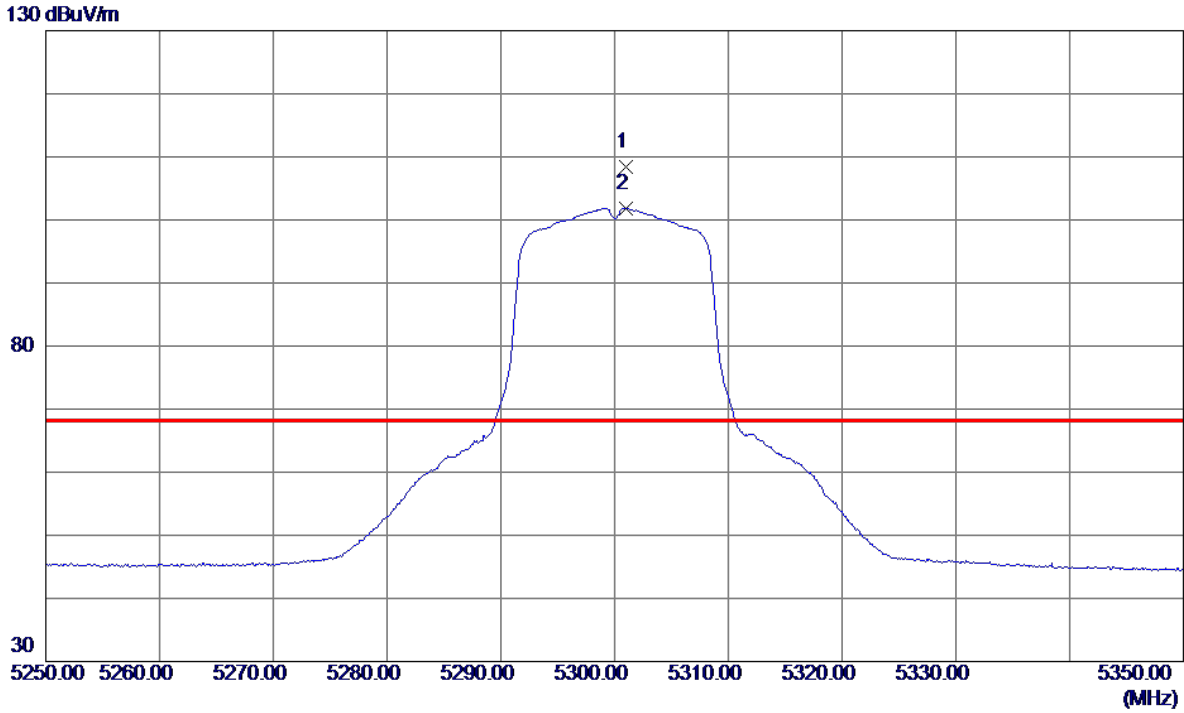

No.	Freq. MHz	Reading Level dBuV/m	Correct Factor dB	Measure ment dBuV/m	Limit dBuV/m	Margin dB	Detector	Comment
1 *	5301.0000	91.33	17.07	108.40	68.30	40.10	Peak	No Limit
2	5301.0000	84.76	17.07	101.83	999.00	-897.17	AVG	No Limit

Orthogonal Axis :	X
Test Mode :	UNII-2A/ TX A Mode 5300MHz

Horizontal

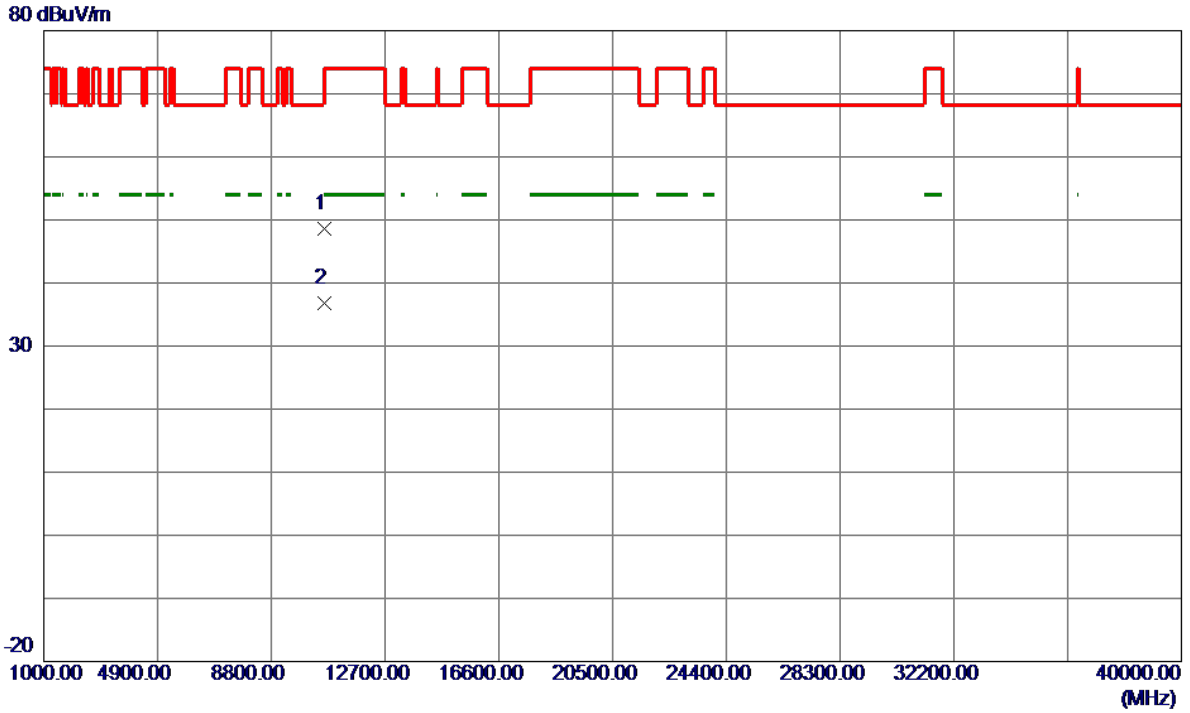

No.	Freq. MHz	Reading Level dBuV/m	Correct Factor dB	Measure ment dBuV/m	Limit dBuV/m	Margin dB	Detector	Comment
1	10601.1900	33.44	15.16	48.60	74.00	-25.40	Peak	
2 *	10601.5450	21.59	15.16	36.75	54.00	-17.25	AVG	

Orthogonal Axis :	X
Test Mode :	UNII-2A/ TX A Mode 5320MHz

Vertical

130 dBuV/m

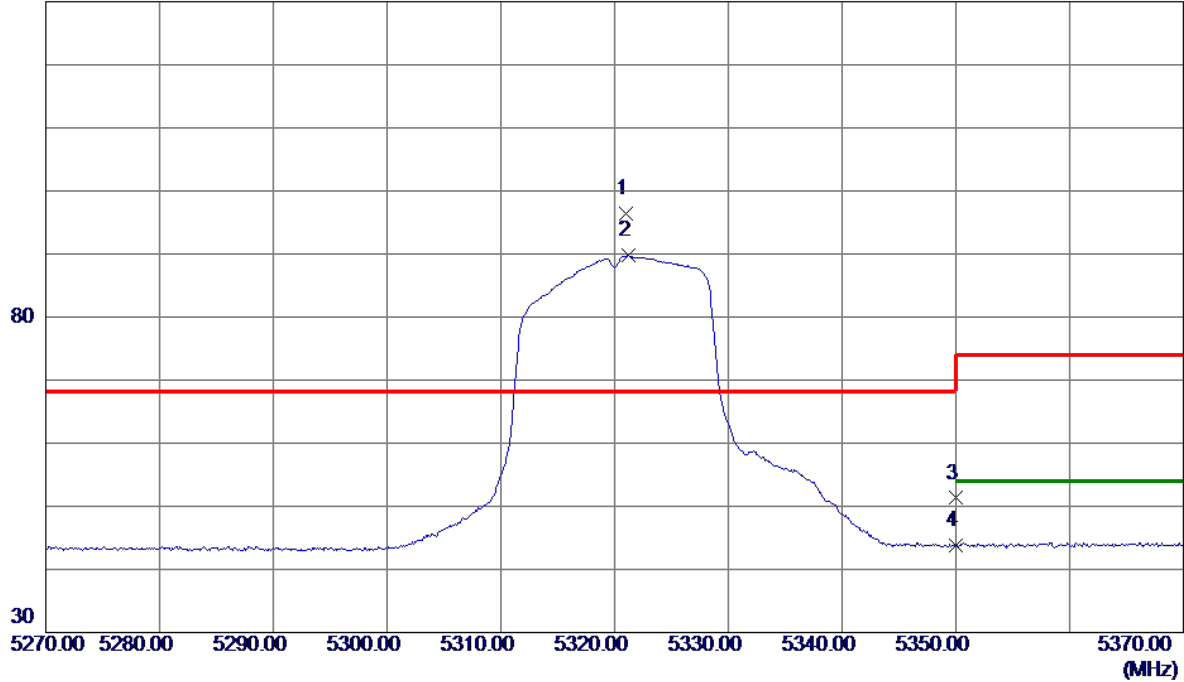

No.	Freq. MHz	Reading Level dBuV/m	Correct Factor dB	Measure ment dBuV/m	Limit dBuV/m	Margin dB	Detector	Comment
1 *	5321.0000	79.26	17.13	96.39	68.30	28.09	Peak	No Limit
2	5321.2000	72.63	17.13	89.76	999.00	-909.24	AVG	No Limit
3	5350.0000	34.09	17.21	51.30	74.00	-22.70	Peak	
4	5350.0000	26.63	17.21	43.84	999.00	-955.16	AVG	

Orthogonal Axis :	X
Test Mode :	UNII-2A/ TX A Mode 5320MHz

Vertical

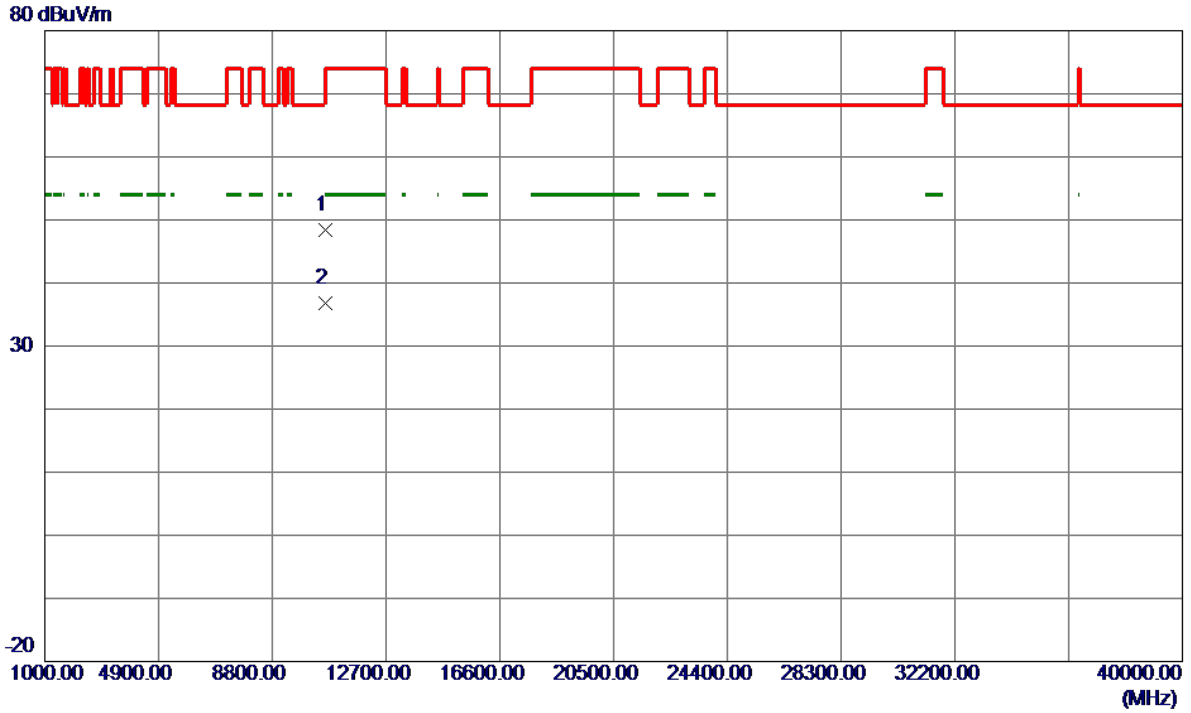

No.	Freq. MHz	Reading Level dBuV/m	Correct Factor dB	Measure ment dBuV/m	Limit dBuV/m	Margin dB	Detector	Comment
1	10639.5800	33.21	15.19	48.40	74.00	-25.60	Peak	
2 *	10641.5100	21.69	15.19	36.88	54.00	-17.12	AVG	

Orthogonal Axis :	X
Test Mode :	UNII-2A/ TX A Mode 5320MHz

Horizontal

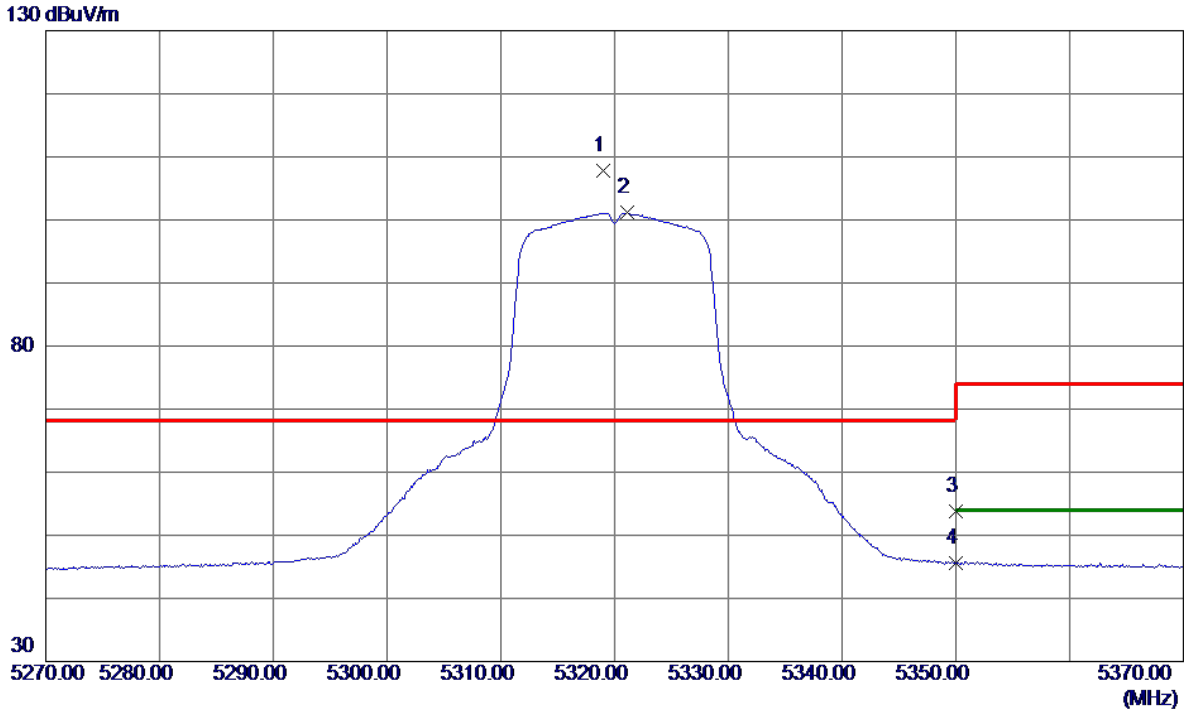

No.	Freq. MHz	Reading Level dBuV/m	Correct Factor dB	Measure ment dBuV/m	Limit dBuV/m	Margin dB	Detector	Comment
1 *	5319.0000	90.65	17.13	107.78	68.30	39.48	Peak	No Limit
2	5321.1000	83.99	17.13	101.12	999.00	-897.88	AVG	No Limit
3	5350.0000	36.68	17.21	53.89	74.00	-20.11	Peak	
4	5350.0000	28.43	17.21	45.64	999.00	-953.36	AVG	

Orthogonal Axis :	X
Test Mode :	UNII-2A/ TX A Mode 5320MHz

Horizontal

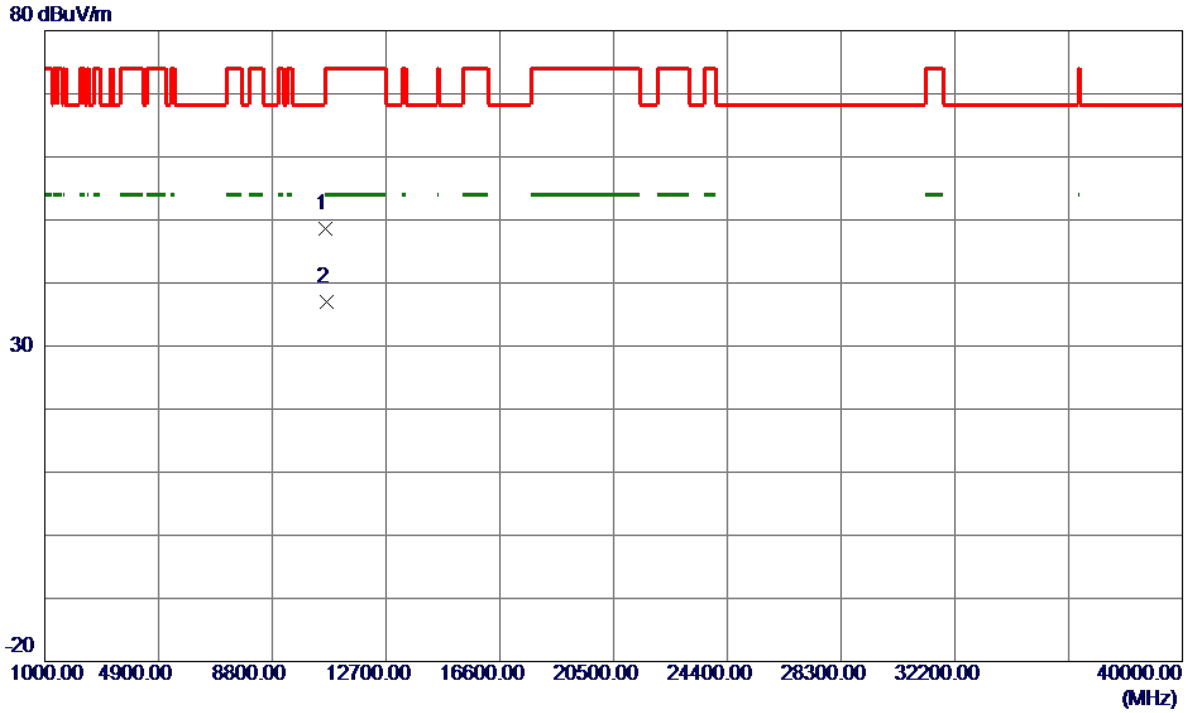

No.	Freq. MHz	Reading Level dBuV/m	Correct Factor dB	Measure ment dBuV/m	Limit dBuV/m	Margin dB	Detector	Comment
1	10638.4150	33.38	15.19	48.57	74.00	-25.43	Peak	
2 *	10641.9300	21.76	15.19	36.95	54.00	-17.05	AVG	

Orthogonal Axis :	X
Test Mode :	UNII-2A/ TX N20 Mode 5260MHz

Vertical

130 dBuV/m

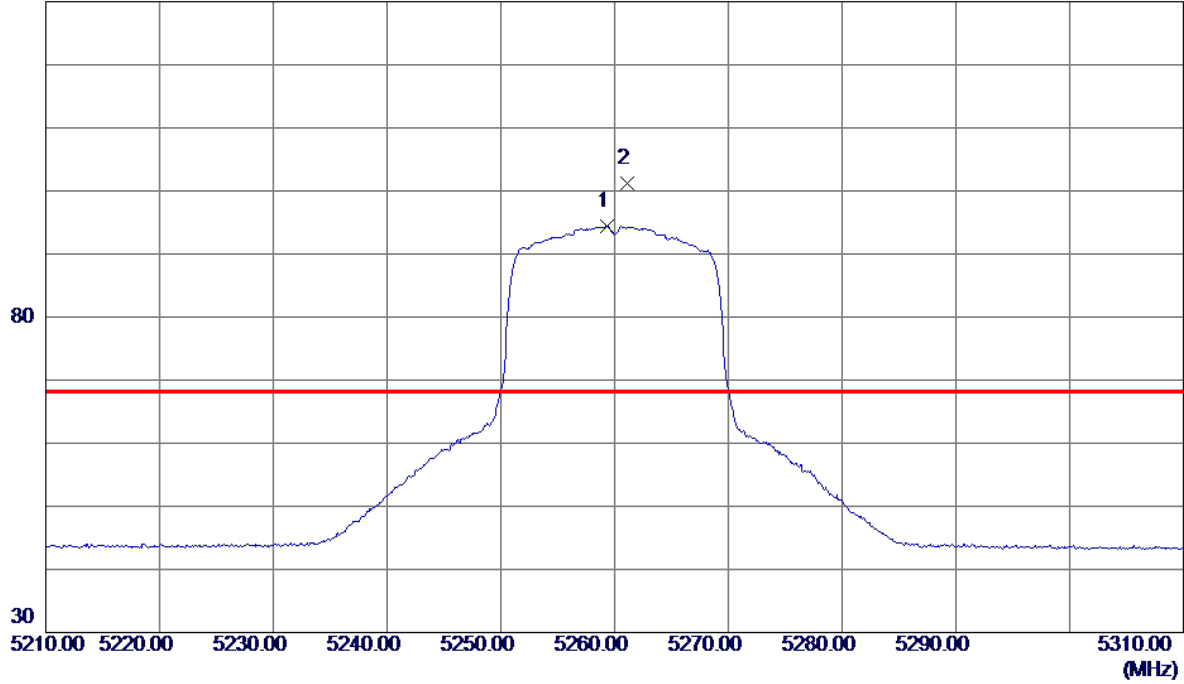

No.	Freq. MHz	Reading Level dBuV/m	Correct Factor dB	Measure ment dBuV/m	Limit dBuV/m	Margin dB	Detector	Comment
1	5259.3000	77.45	16.96	94.41	999.00	-904.59	AVG	No Limit
2 *	5261.1000	84.21	16.96	101.17	68.30	32.87	Peak	No Limit

Orthogonal Axis :	X
Test Mode :	UNII-2A/ TX N20 Mode 5260MHz

Vertical

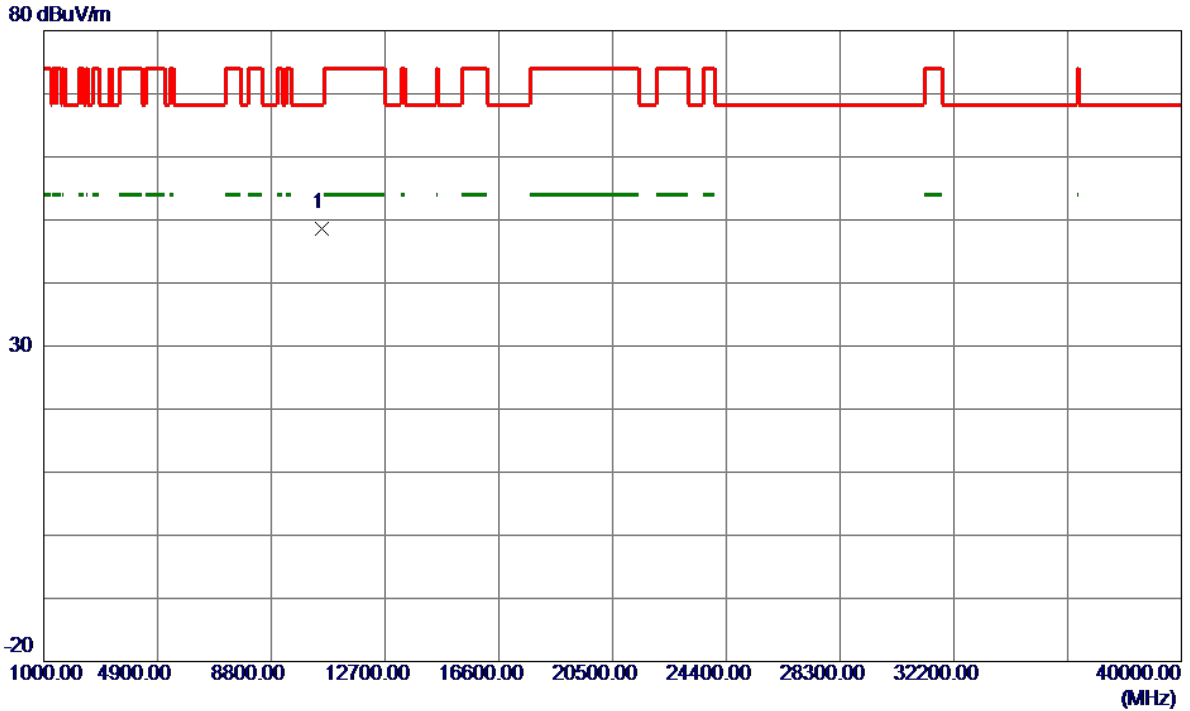

No.	Freq. MHz	Reading Level dBuV/m	Correct Factor dB	Measure ment dBuV/m	Limit dBuV/m	Margin dB	Detector	Comment
1 *	10517.9100	33.59	15.11	48.70	68.30	-19.60	Peak	

Orthogonal Axis :	X
Test Mode :	UNII-2A/ TX N20 Mode 5260MHz

Horizontal

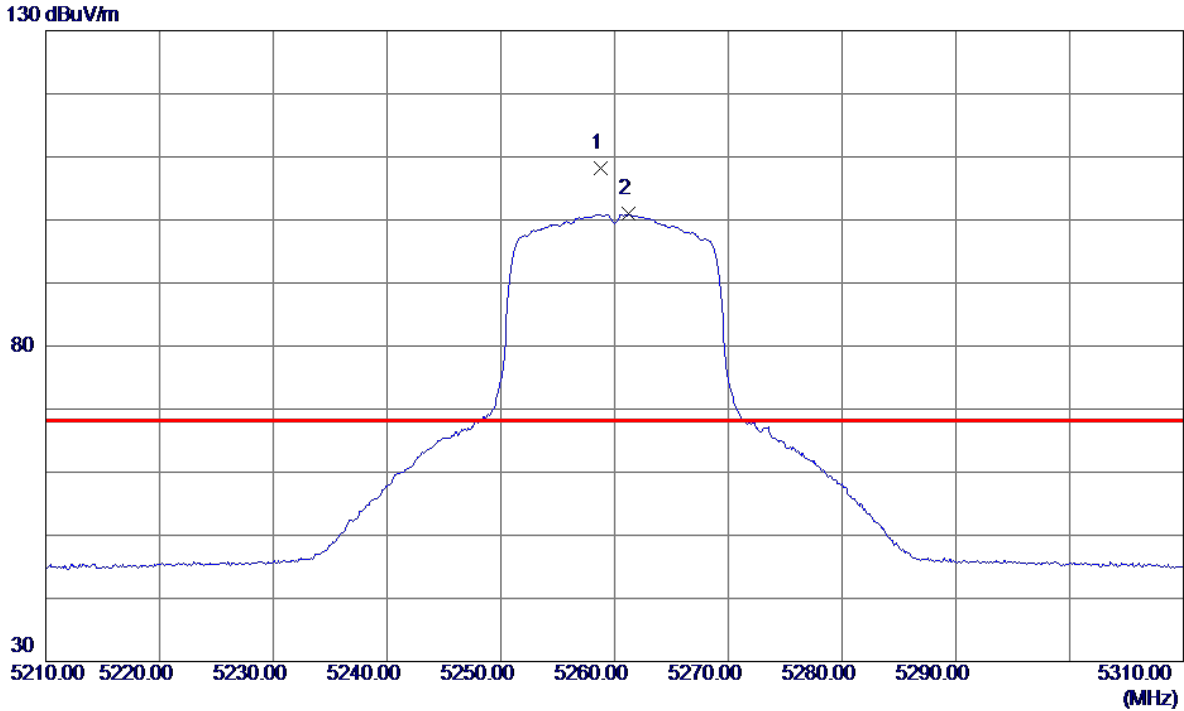

No.	Freq. MHz	Reading Level dBuV/m	Correct Factor dB	Measure ment dBuV/m	Limit dBuV/m	Margin dB	Detector	Comment
1 *	5258.8000	91.28	16.95	108.23	68.30	39.93	Peak	No Limit
2	5261.2000	83.94	16.96	100.90	999.00	-898.10	AVG	No Limit

Orthogonal Axis :	X
Test Mode :	UNII-2A/ TX N20 Mode 5260MHz

Horizontal

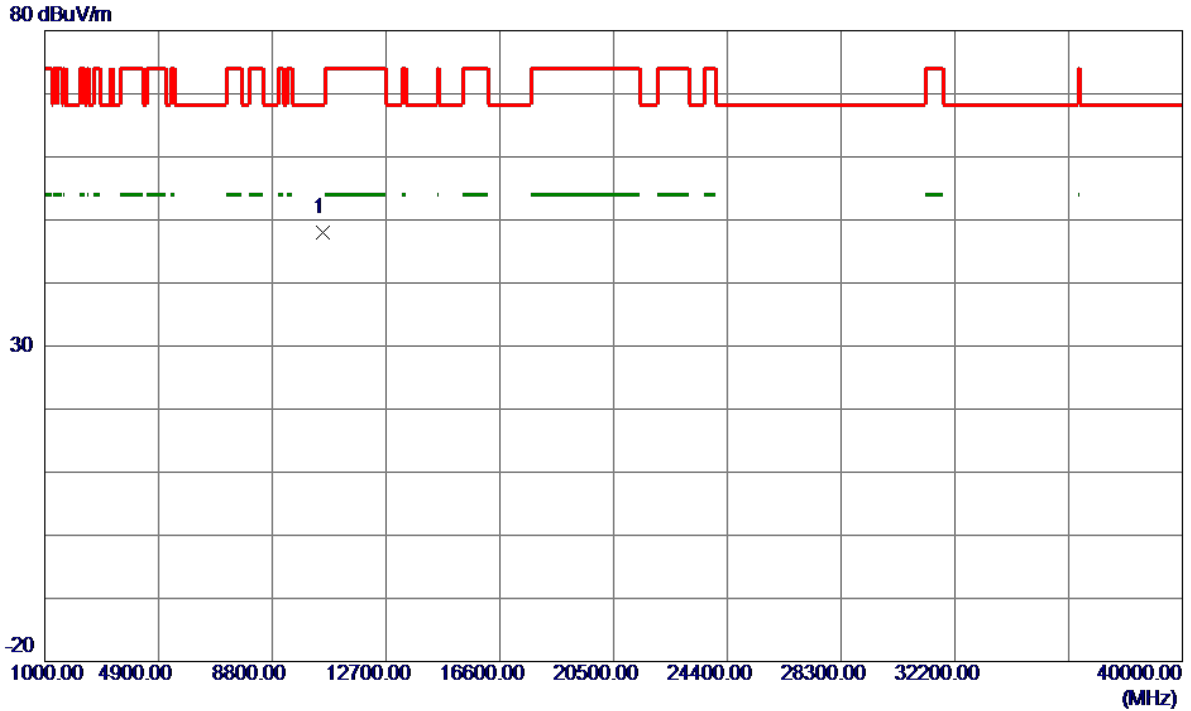

No.	Freq. MHz	Reading Level dBuV/m	Correct Factor dB	Measure ment dBuV/m	Limit dBuV/m	Margin dB	Detector	Comment
1 *	10517.5599	32.80	15.11	47.91	68.30	-20.39	Peak	

Orthogonal Axis :	X
Test Mode :	UNII-2A/ TX N20 Mode 5300MHz

Vertical

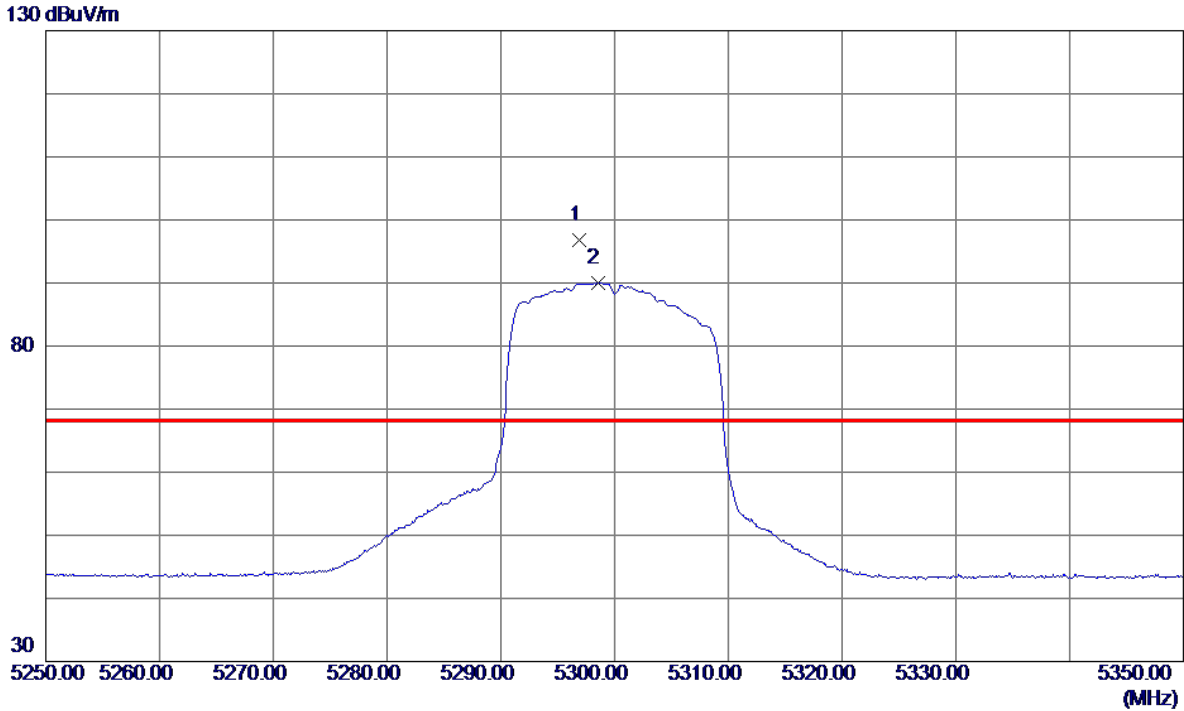

No.	Freq. MHz	Reading Level dBuV/m	Correct Factor dB	Measure ment dBuV/m	Limit dBuV/m	Margin dB	Detector	Comment
1 *	5296.9000	79.83	17.06	96.89	68.30	28.59	Peak	No Limit
2	5298.5000	73.00	17.07	90.07	999.00	-908.93	AVG	No Limit

Orthogonal Axis :	X
Test Mode :	UNII-2A/ TX N20 Mode 5300MHz

Vertical

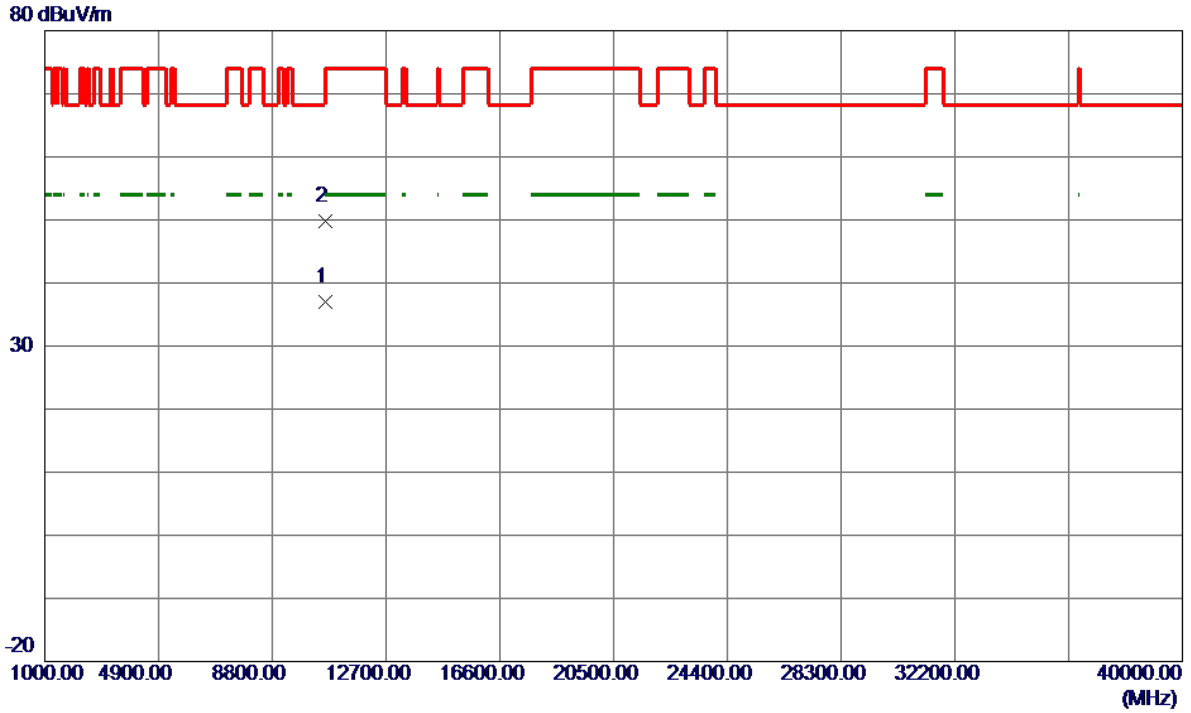

No.	Freq. MHz	Reading Level dBuV/m	Correct Factor dB	Measure ment dBuV/m	Limit dBuV/m	Margin dB	Detector	Comment
1 *	10600.4450	21.91	15.16	37.07	54.00	-16.93	AVG	
2	10600.5199	34.65	15.16	49.81	74.00	-24.19	Peak	

Orthogonal Axis :	X
Test Mode :	UNII-2A/ TX N20 Mode 5300MHz

Horizontal

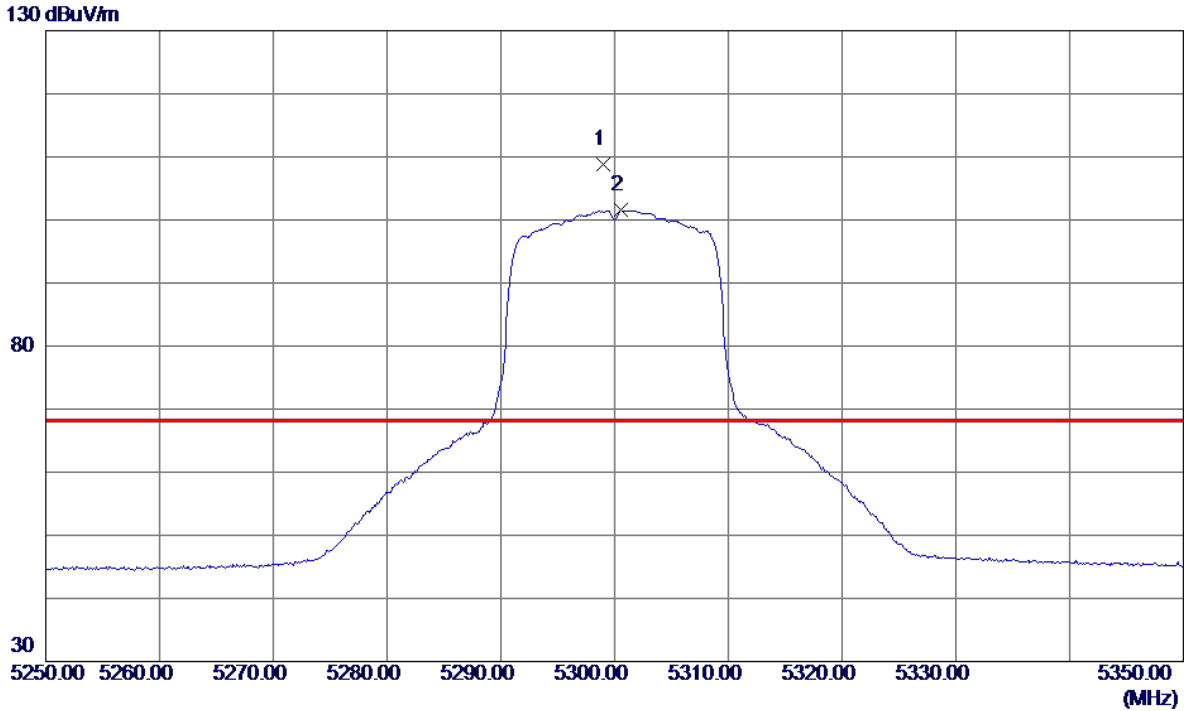

No.	Freq. MHz	Reading Level dBuV/m	Correct Factor dB	Measure ment dBuV/m	Limit dBuV/m	Margin dB	Detector	Comment
1 *	5299.0000	91.77	17.07	108.84	68.30	40.54	Peak	No Limit
2	5300.6000	84.44	17.07	101.51	999.00	-897.49	AVG	No Limit

Orthogonal Axis :	X
Test Mode :	UNII-2A/ TX N20 Mode 5300MHz

Horizontal

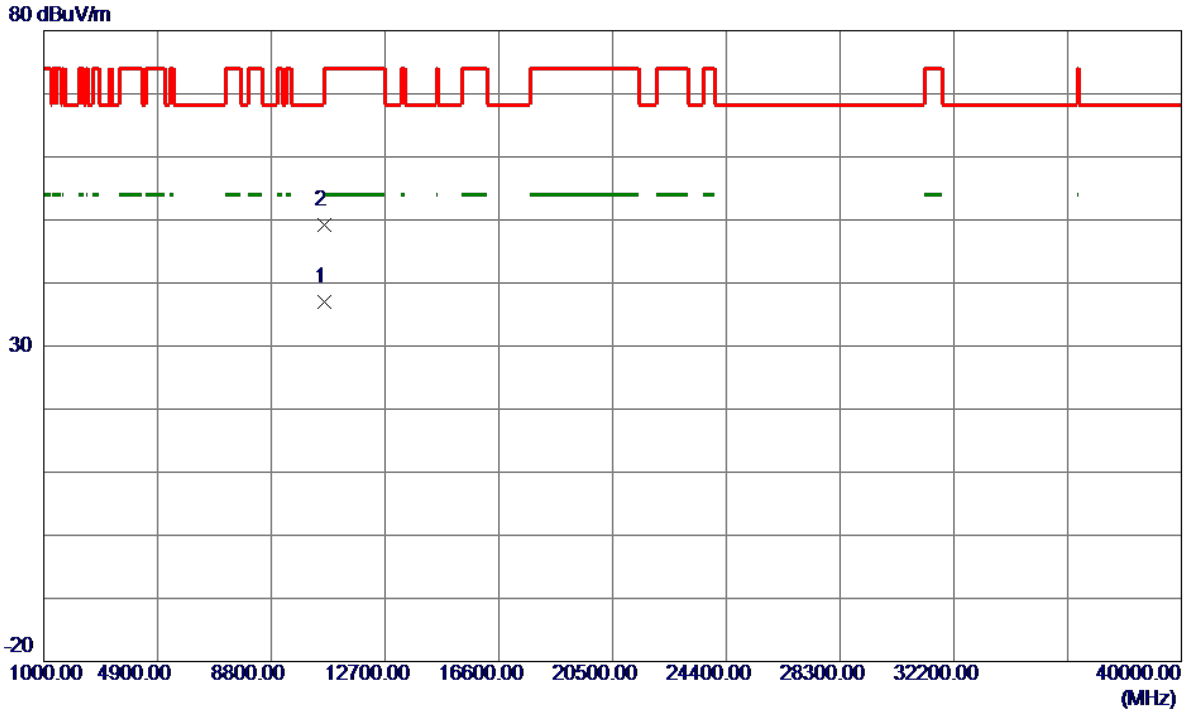

No.	Freq. MHz	Reading Level dBuV/m	Correct Factor dB	Measure ment dBuV/m	Limit dBuV/m	Margin dB	Detector	Comment
1 *	10600.7350	21.87	15.16	37.03	54.00	-16.97	AVG	
2	10602.5100	34.12	15.16	49.28	74.00	-24.72	Peak	

Orthogonal Axis :	X
Test Mode :	UNII-2A/ TX N20 Mode 5320MHz

Vertical

130 dBuV/m

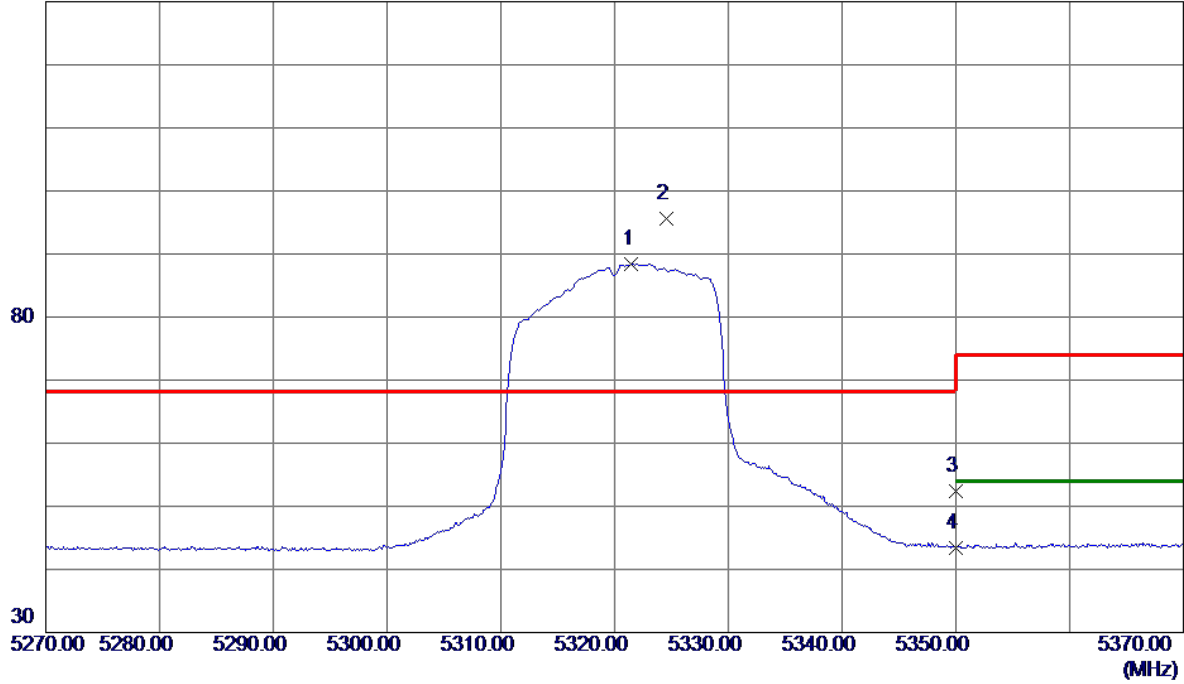

No.	Freq. MHz	Reading Level dBuV/m	Correct Factor dB	Measure ment dBuV/m	Limit dBuV/m	Margin dB	Detector	Comment
1	5321.5000	71.31	17.13	88.44	999.00	-910.56	AVG	No Limit
2 *	5324.6000	78.46	17.14	95.60	68.30	27.30	Peak	No Limit
3	5350.0000	35.14	17.21	52.35	74.00	-21.65	Peak	
4	5350.0000	26.25	17.21	43.46	999.00	-955.54	AVG	

Orthogonal Axis :	X
Test Mode :	UNII-2A/ TX N20 Mode 5320MHz

Vertical

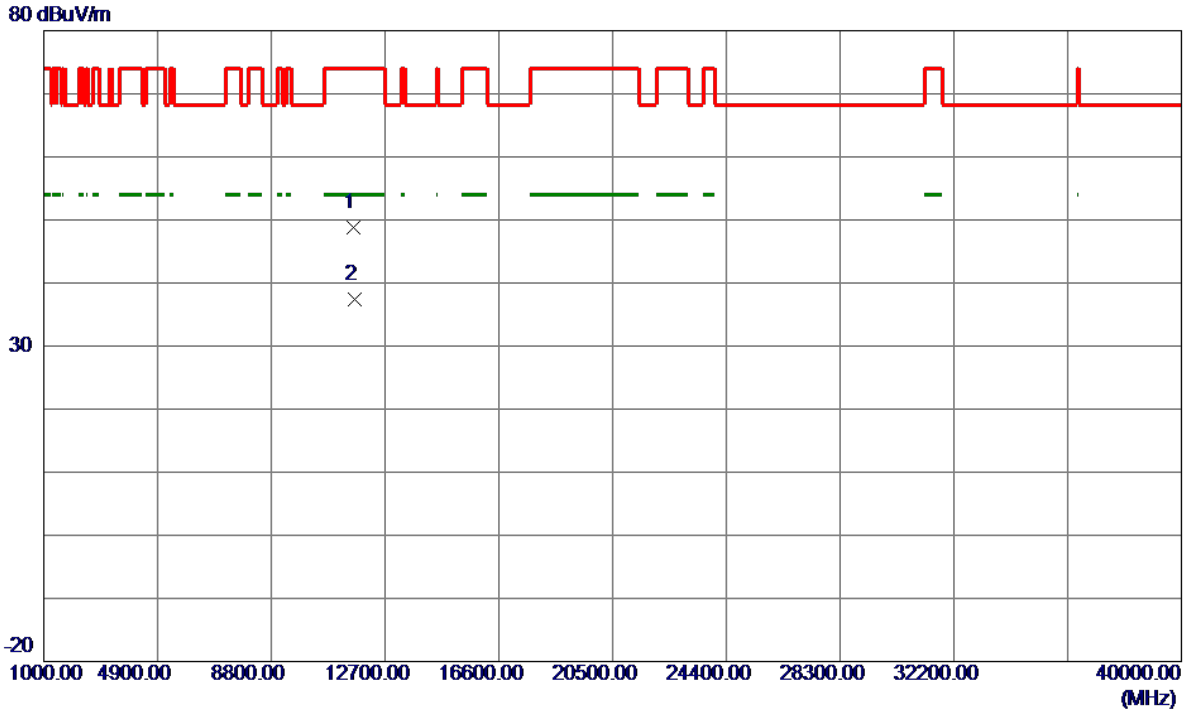

No.	Freq. MHz	Reading Level dBuV/m	Correct Factor dB	Measure ment dBuV/m	Limit dBuV/m	Margin dB	Detector	Comment
1	11637.9850	32.84	16.03	48.87	74.00	-25.13	Peak	
2 *	11639.9700	21.38	16.03	37.41	54.00	-16.59	AVG	

Orthogonal Axis :	X
Test Mode :	UNII-2A/ TX N20 Mode 5320MHz

Horizontal

130 dBuV/m

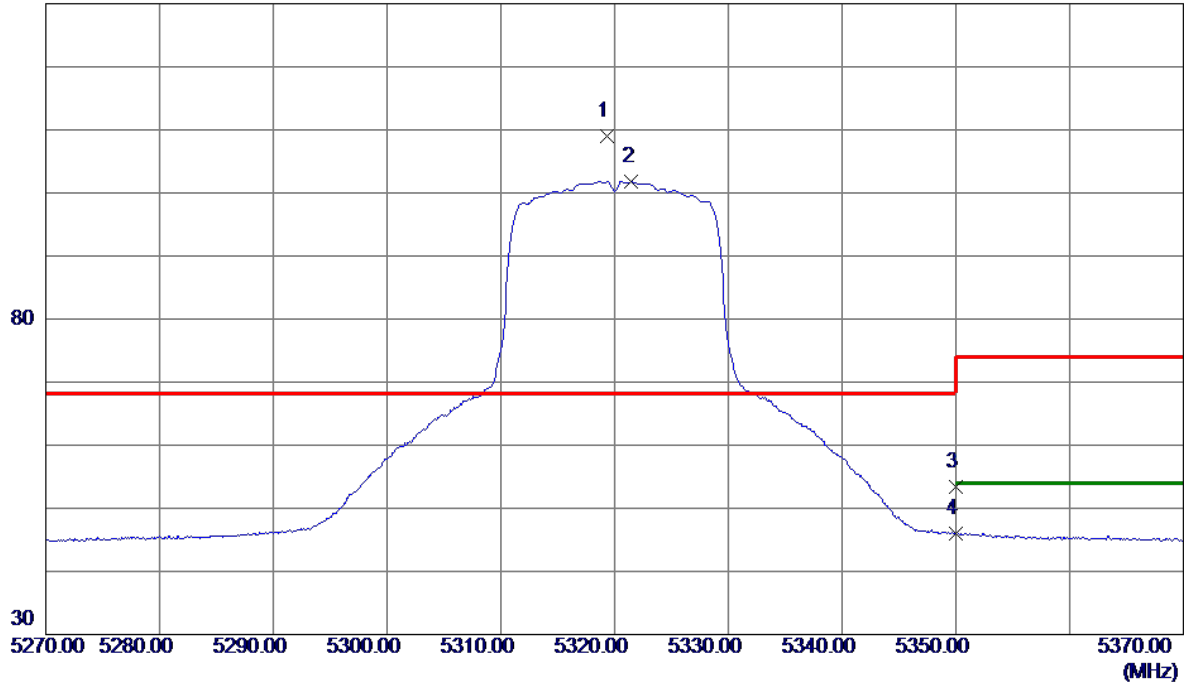

No.	Freq. MHz	Reading Level dBuV/m	Correct Factor dB	Measure ment dBuV/m	Limit dBuV/m	Margin dB	Detector	Comment
1 *	5319.3000	91.96	17.13	109.09	68.30	40.79	Peak	No Limit
2	5321.5000	84.64	17.13	101.77	999.00	-897.23	AVG	No Limit
3	5350.0000	36.28	17.21	53.49	74.00	-20.51	Peak	
4	5350.0000	28.75	17.21	45.96	999.00	-953.04	AVG	

Orthogonal Axis :	X
Test Mode :	UNII-2A/ TX N20 Mode 5320MHz

Horizontal

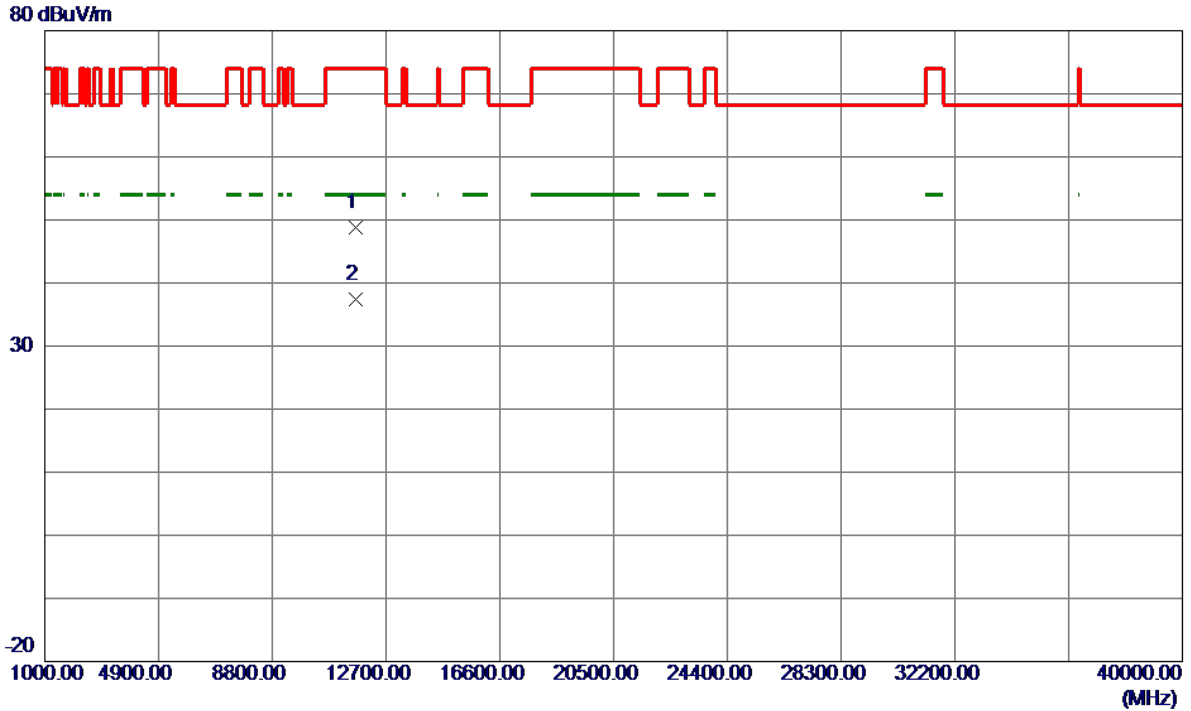

No.	Freq. MHz	Reading Level dBuV/m	Correct Factor dB	Measure ment dBuV/m	Limit dBuV/m	Margin dB	Detector	Comment
1	11639.0700	32.82	16.03	48.85	74.00	-25.15	Peak	
2 *	11642.2500	21.35	16.03	37.38	54.00	-16.62	AVG	

Orthogonal Axis :	X
Test Mode :	UNII-2A/ TX N40 Mode 5270MHz

Vertical

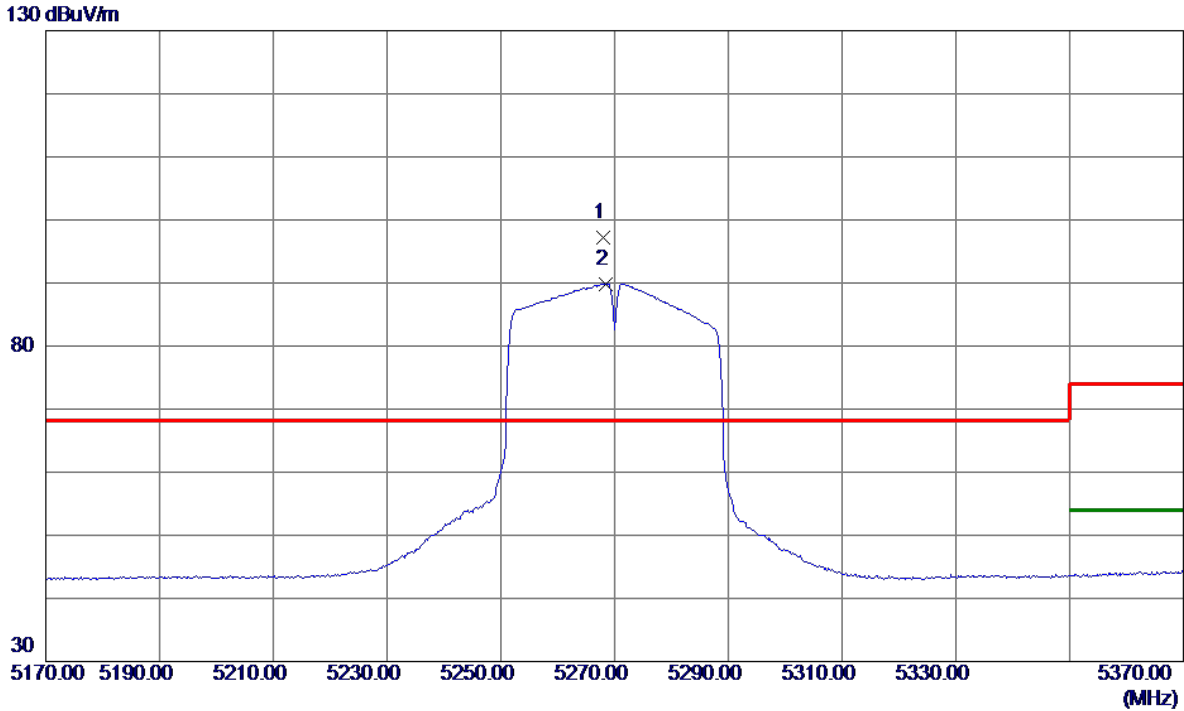

No.	Freq. MHz	Reading Level dBuV/m	Correct Factor dB	Measure ment dBuV/m	Limit dBuV/m	Margin dB	Detector	Comment
1 *	5268.0000	80.23	16.98	97.21	68.30	28.91	Peak	No Limit
2	5268.4000	72.91	16.98	89.89	999.00	-909.11	AVG	No Limit

Orthogonal Axis :	X
Test Mode :	UNII-2A/ TX N40 Mode 5270MHz

Vertical

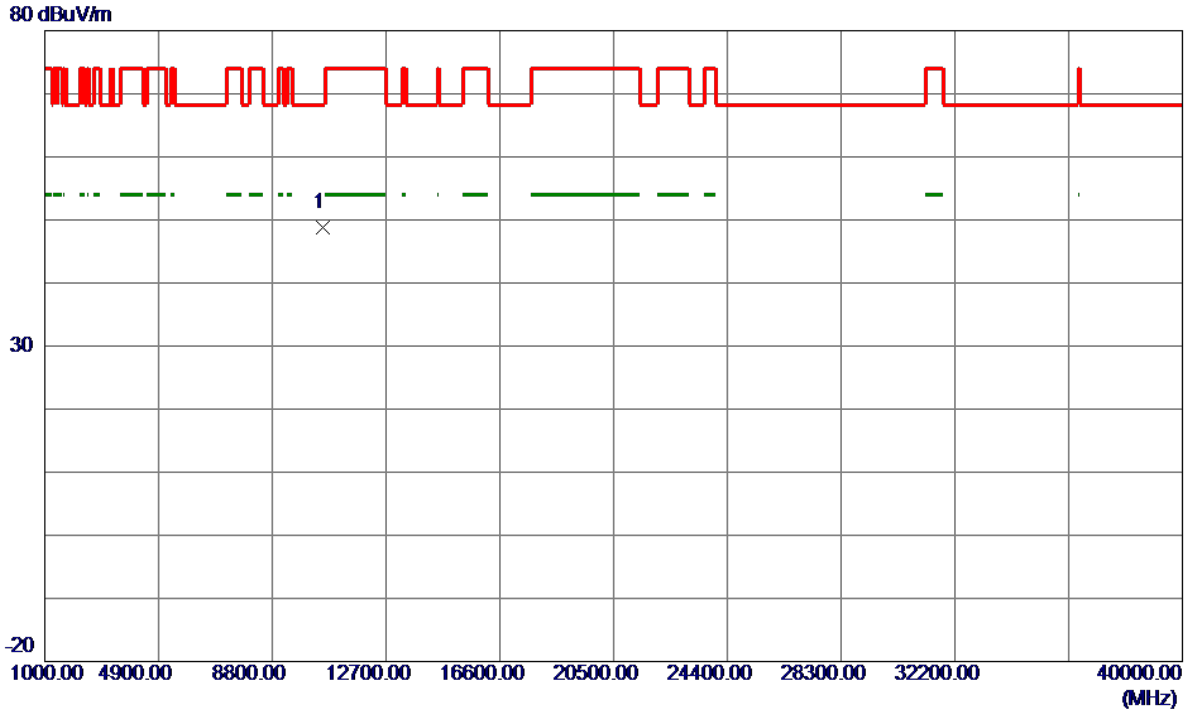

No.	Freq. MHz	Reading Level dBuV/m	Correct Factor dB	Measure ment dBuV/m	Limit dBuV/m	Margin dB	Detector	Comment
1 *	10537.9600	33.67	15.12	48.79	68.30	-19.51	Peak	

Orthogonal Axis :	X
Test Mode :	UNII-2A/ TX N40 Mode 5270MHz

Horizontal

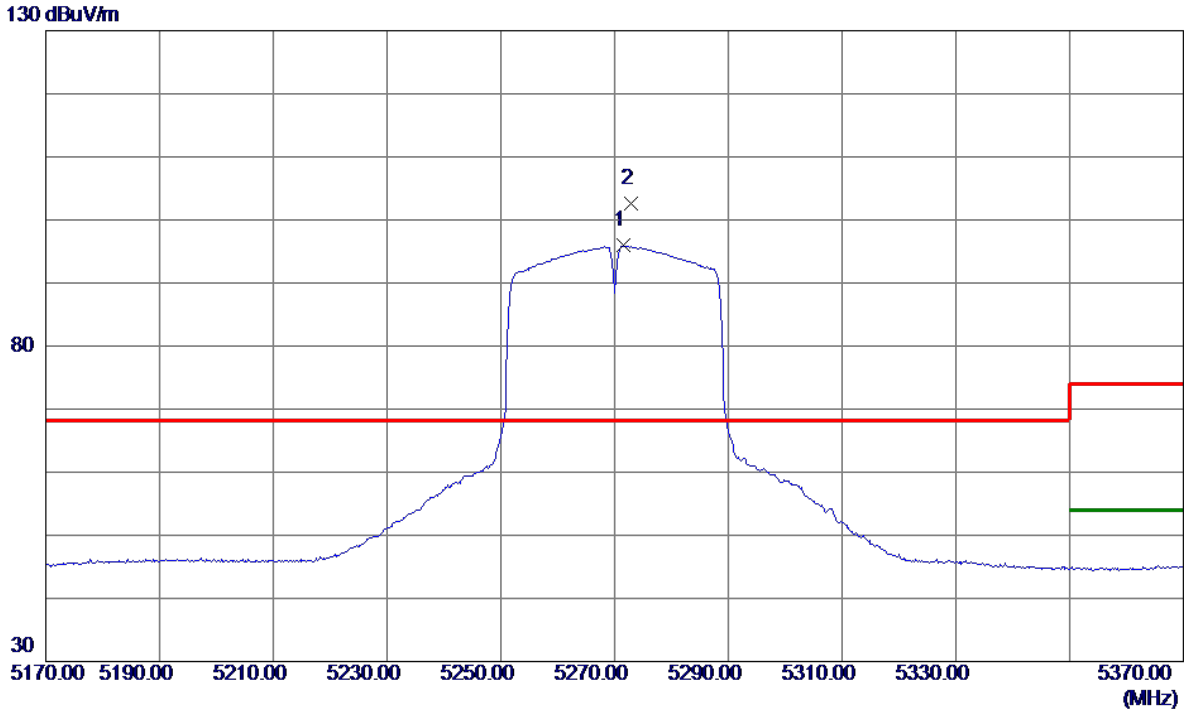

No.	Freq. MHz	Reading Level dBuV/m	Correct Factor dB	Measure ment dBuV/m	Limit dBuV/m	Margin dB	Detector	Comment
1	5271.6000	78.91	16.99	95.90	999.00	-903.10	AVG	No Limit
2 *	5272.8000	85.66	16.99	102.65	68.30	34.35	Peak	No Limit

Orthogonal Axis :	X
Test Mode :	UNII-2A/ TX N40 Mode 5270MHz

Horizontal

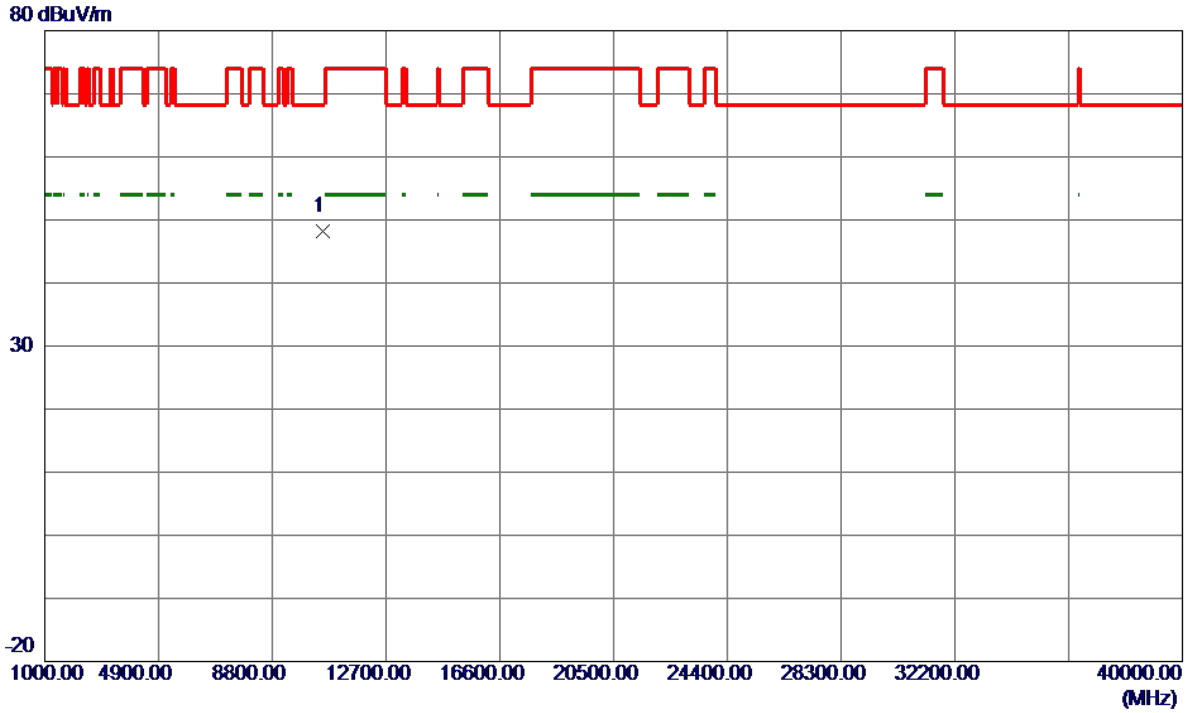

No.	Freq. MHz	Reading Level dBuV/m	Correct Factor dB	Measure ment dBuV/m	Limit dBuV/m	Margin dB	Detector	Comment
1 *	10542.1800	33.10	15.12	48.22	68.30	-20.08	Peak	

Orthogonal Axis :	X
Test Mode :	UNII-2A/ TX N40 Mode 5310MHz

Vertical

130 dBuV/m

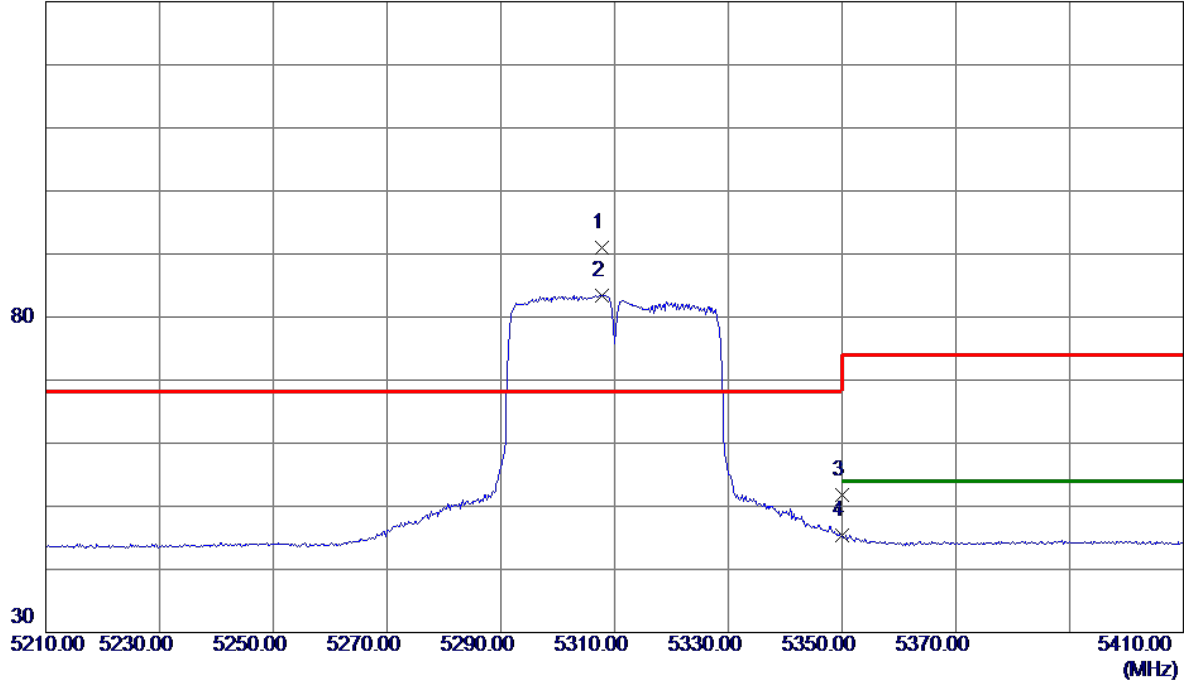

No.	Freq. MHz	Reading Level dBuV/m	Correct Factor dB	Measure ment dBuV/m	Limit dBuV/m	Margin dB	Detector	Comment
1 *	5307.8000	74.00	17.09	91.09	68.30	22.79	Peak	No Limit
2	5307.8000	66.32	17.09	83.41	999.00	-915.59	AVG	No Limit
3	5350.0000	34.58	17.21	51.79	74.00	-22.21	Peak	
4	5350.0000	28.12	17.21	45.33	999.00	-953.67	AVG	

Orthogonal Axis :	X
Test Mode :	UNII-2A/ TX N40 Mode 5310MHz

Vertical

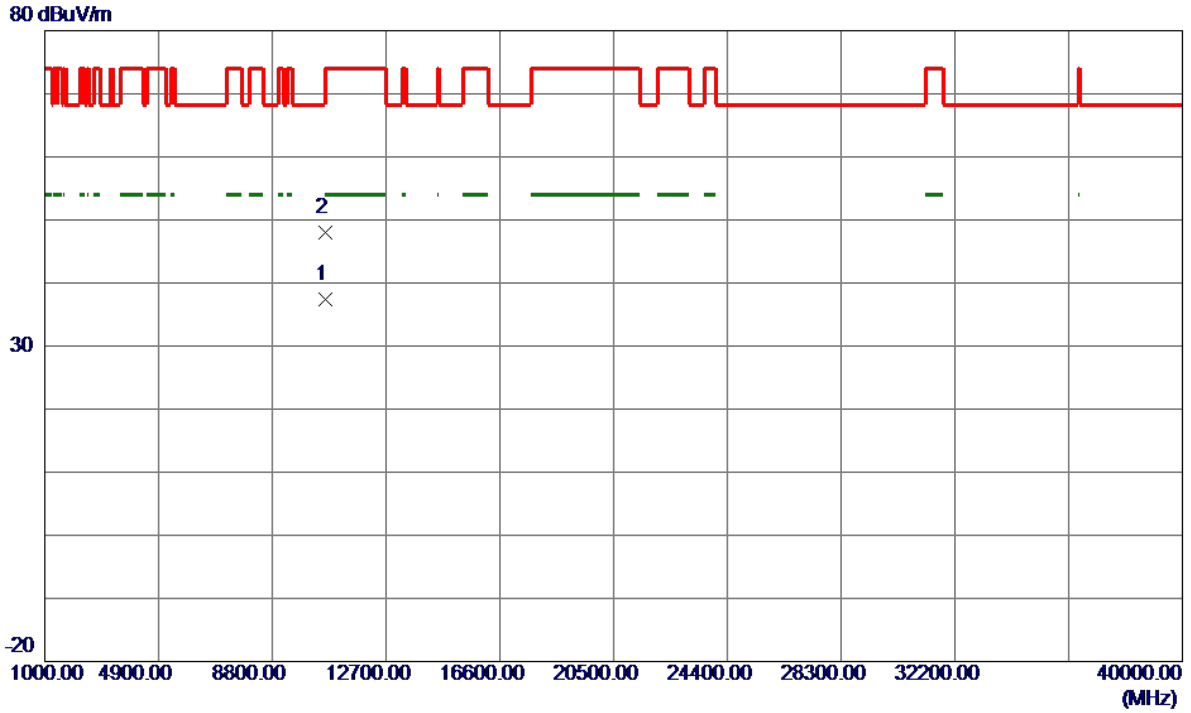

No.	Freq. MHz	Reading Level dBuV/m	Correct Factor dB	Measure ment dBuV/m	Limit dBuV/m	Margin dB	Detector	Comment
1 *	10621.0850	22.20	15.18	37.38	54.00	-16.62	AVG	
2	10621.6700	32.82	15.18	48.00	74.00	-26.00	Peak	

Orthogonal Axis :	X
Test Mode :	UNII-2A/ TX N40 Mode 5310MHz

Horizontal

130 dBuV/m

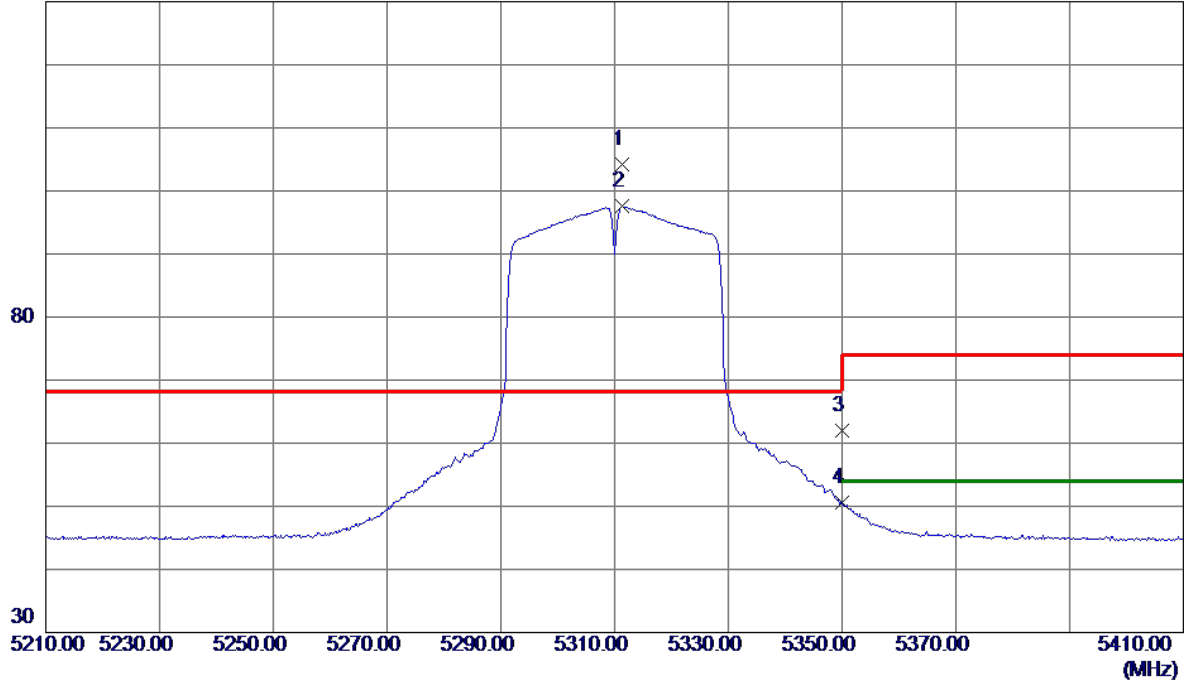

No.	Freq. MHz	Reading Level dBuV/m	Correct Factor dB	Measure ment dBuV/m	Limit dBuV/m	Margin dB	Detector	Comment
1 *	5311.4000	87.13	17.10	104.23	68.30	35.93	Peak	No Limit
2	5311.4000	80.43	17.10	97.53	999.00	-901.47	AVG	No Limit
3	5350.0000	44.71	17.21	61.92	74.00	-12.08	Peak	
4	5350.0000	33.37	17.21	50.58	999.00	-948.42	AVG	

Orthogonal Axis :	X
Test Mode :	UNII-2A/ TX N40 Mode 5310MHz

Horizontal

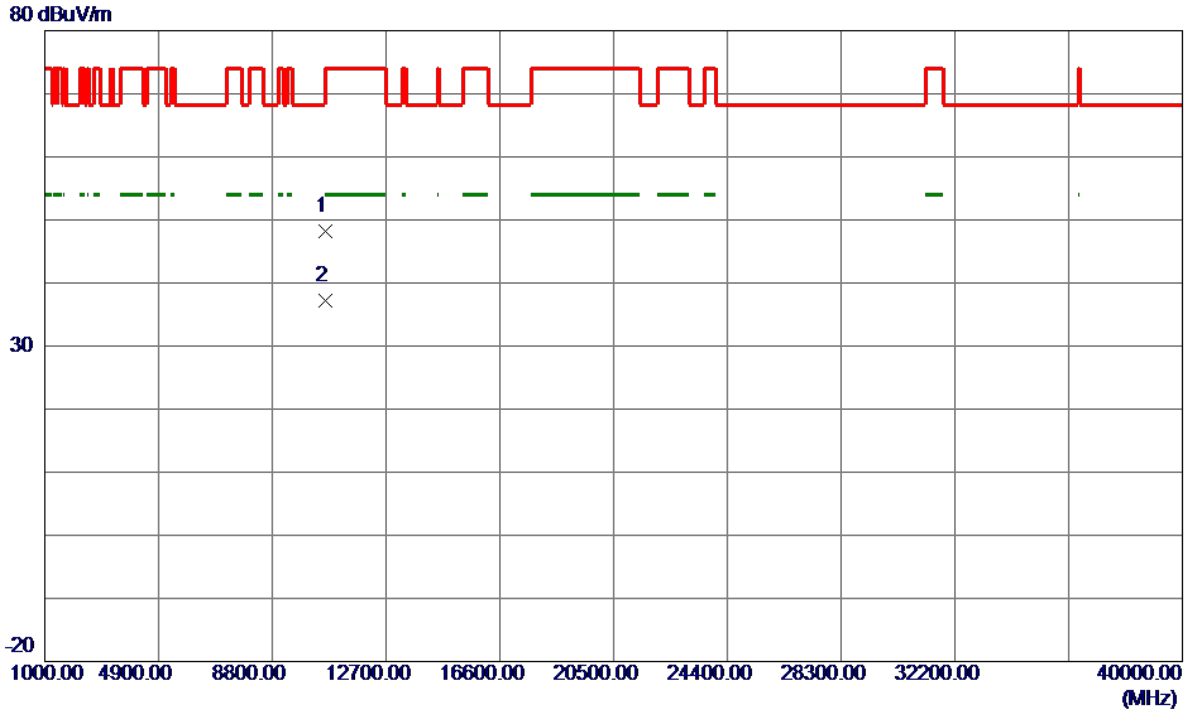

No.	Freq. MHz	Reading Level dBuV/m	Correct Factor dB	Measure ment dBuV/m	Limit dBuV/m	Margin dB	Detector	Comment
1	10621.5300	33.07	15.18	48.25	74.00	-25.75	Peak	
2 *	10621.7550	22.11	15.18	37.29	54.00	-16.71	AVG	

Orthogonal Axis :	X
Test Mode :	UNII-2C/ TX A Mode 5500MHz

Vertical

130 dBuV/m

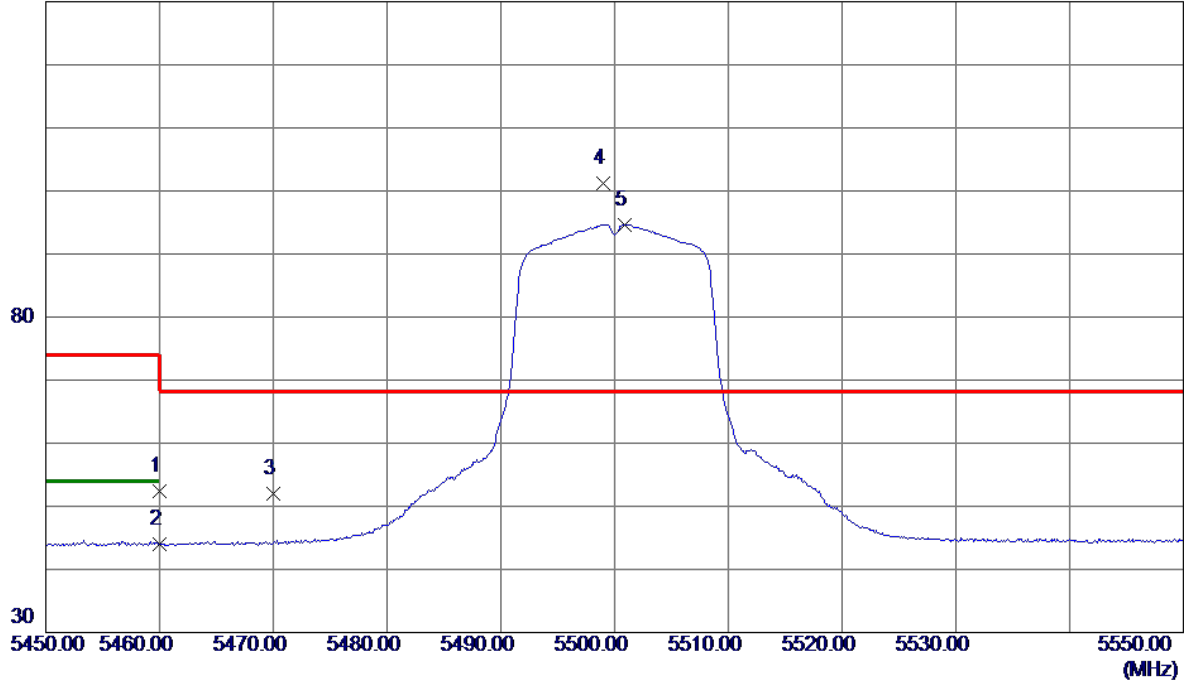

No.	Freq. MHz	Reading Level dBuV/m	Correct Factor dB	Measure ment dBuV/m	Limit dBuV/m	Margin dB	Detector	Comment
1	5460.0000	34.85	17.53	52.38	74.00	-21.62	Peak	
2	5460.0000	26.38	17.53	43.91	54.00	-10.09	AVG	
3	5470.0000	34.36	17.55	51.91	68.30	-16.39	Peak	
4 *	5499.0000	83.48	17.64	101.12	68.30	32.82	Peak	No Limit
5	5500.9000	77.04	17.64	94.68	999.00	-904.32	AVG	No Limit

Orthogonal Axis :	X
Test Mode :	UNII-2C/ TX A Mode 5500MHz

Vertical

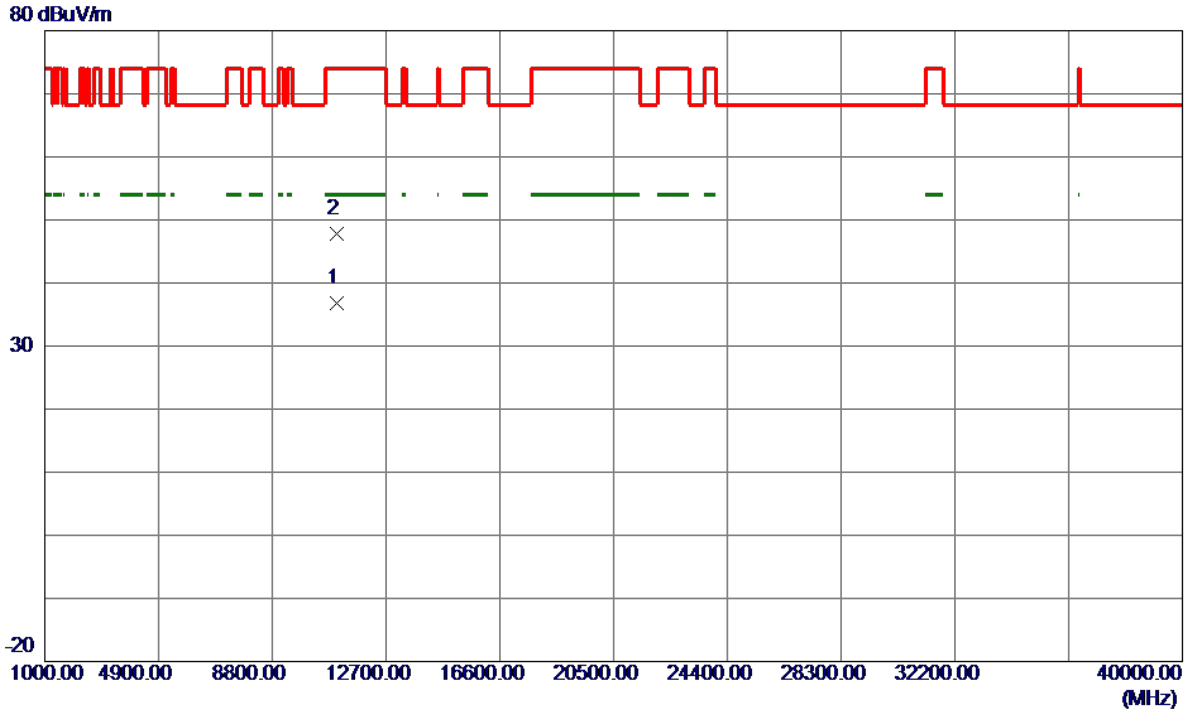

No.	Freq. MHz	Reading Level dBuV/m	Correct Factor dB	Measure ment dBuV/m	Limit dBuV/m	Margin dB	Detector	Comment
1 *	10998.6750	21.32	15.43	36.75	54.00	-17.25	AVG	
2	11000.4100	32.43	15.43	47.86	74.00	-26.14	Peak	

Orthogonal Axis :	X
Test Mode :	UNII-2C/ TX A Mode 5500MHz

Horizontal

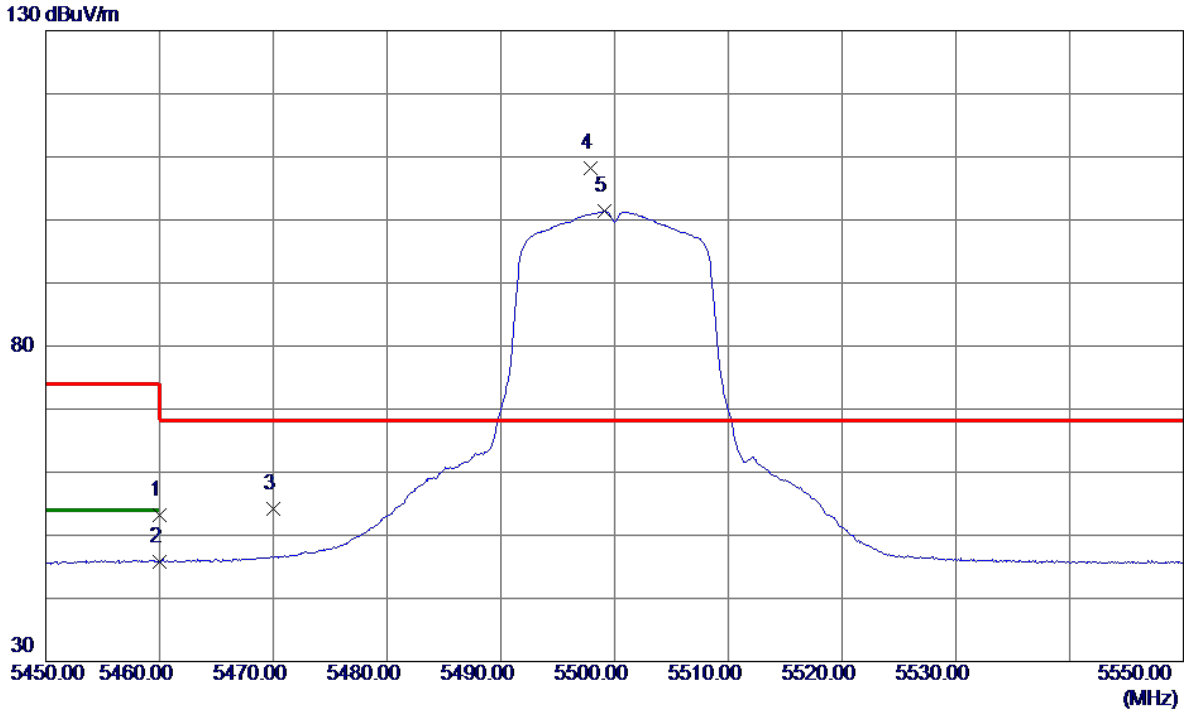

No.	Freq. MHz	Reading Level dBuV/m	Correct Factor dB	Measure ment dBuV/m	Limit dBuV/m	Margin dB	Detector	Comment
1	5460.0000	35.71	17.53	53.24	74.00	-20.76	Peak	
2	5460.0000	28.33	17.53	45.86	54.00	-8.14	AVG	
3	5470.0000	36.57	17.55	54.12	68.30	-14.18	Peak	
4 *	5497.9000	90.65	17.63	108.28	68.30	39.98	Peak	No Limit
5	5499.1000	83.70	17.64	101.34	999.00	-897.66	AVG	No Limit

Orthogonal Axis :	X
Test Mode :	UNII-2C/ TX A Mode 5500MHz

Horizontal

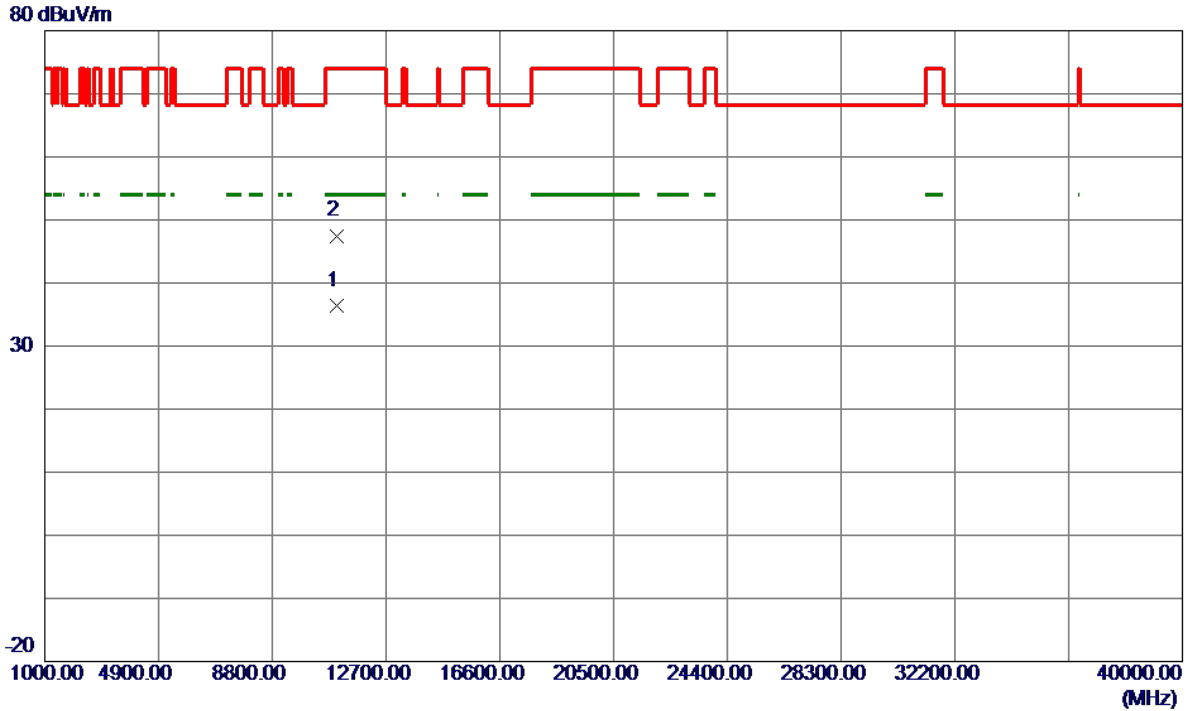

No.	Freq. MHz	Reading Level dBuV/m	Correct Factor dB	Measure ment dBuV/m	Limit dBuV/m	Margin dB	Detector	Comment
1 *	10998.3450	21.05	15.43	36.48	54.00	-17.52	AVG	
2	11001.6300	32.07	15.43	47.50	74.00	-26.50	Peak	

Orthogonal Axis :	X
Test Mode :	UNII-2C/ TX A Mode 5580MHz

Vertical

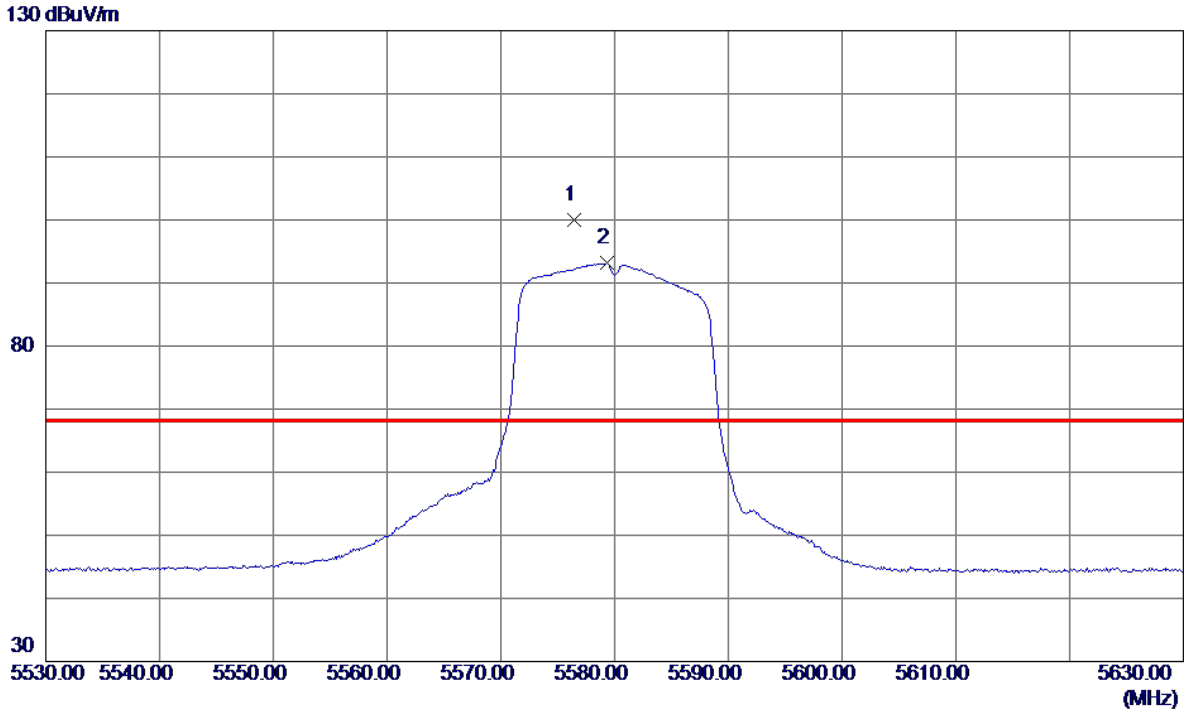

No.	Freq. MHz	Reading Level dBuV/m	Correct Factor dB	Measure ment dBuV/m	Limit dBuV/m	Margin dB	Detector	Comment
1 *	5576.4000	81.99	17.91	99.90	68.30	31.60	Peak	No Limit
2	5579.3000	75.20	17.92	93.12	999.00	-905.88	AVG	No Limit

Orthogonal Axis :	X
Test Mode :	UNII-2C/ TX A Mode 5580MHz

Vertical

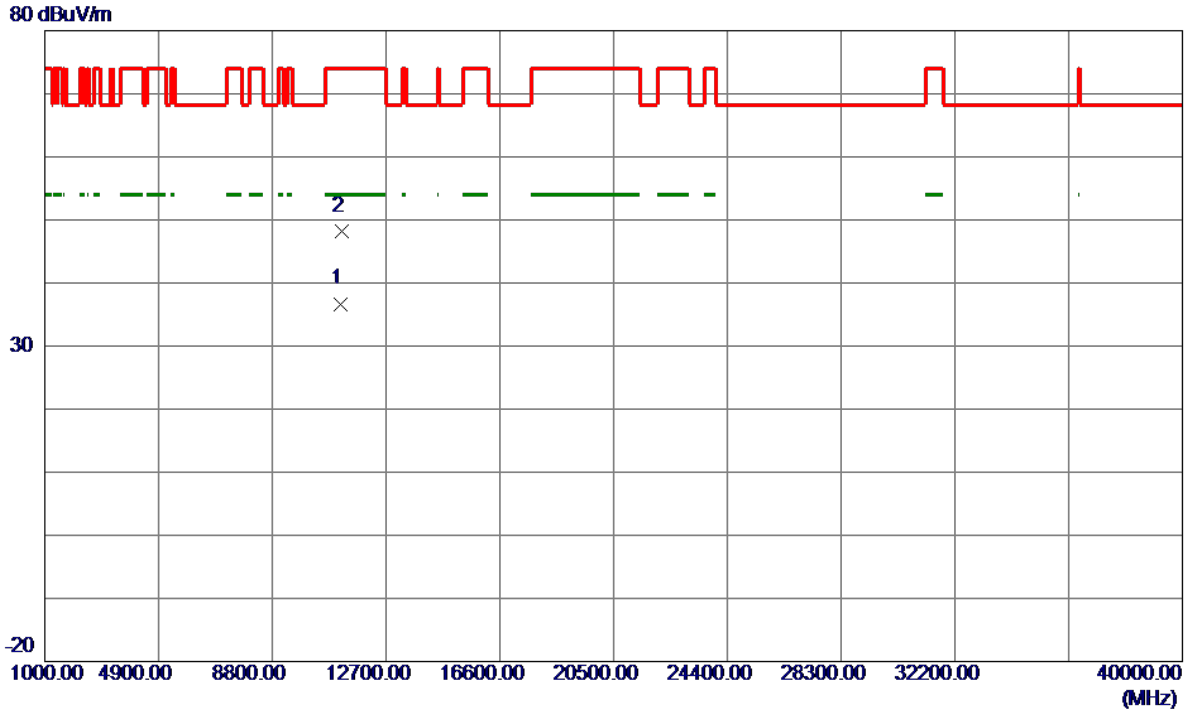

No.	Freq. MHz	Reading Level dBuV/m	Correct Factor dB	Measure ment dBuV/m	Limit dBuV/m	Margin dB	Detector	Comment
1 *	11160.8850	21.10	15.60	36.70	54.00	-17.30	AVG	
2	11162.5000	32.53	15.60	48.13	74.00	-25.87	Peak	

Orthogonal Axis :	X
Test Mode :	UNII-2C/ TX A Mode 5580MHz

Horizontal

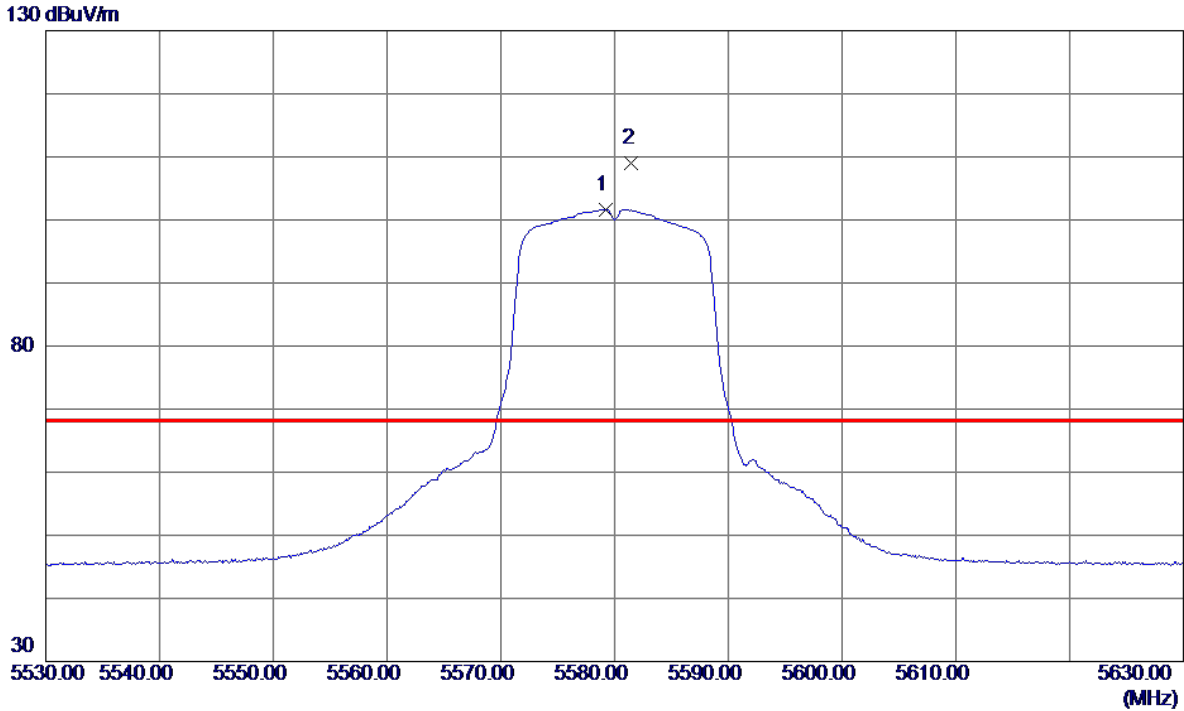

No.	Freq. MHz	Reading Level dBuV/m	Correct Factor dB	Measure ment dBuV/m	Limit dBuV/m	Margin dB	Detector	Comment
1	5579.2000	83.75	17.92	101.67	999.00	-897.33	AVG	No Limit
2 *	5581.5000	91.02	17.93	108.95	68.30	40.65	Peak	No Limit

Orthogonal Axis :	X
Test Mode :	UNII-2C/ TX A Mode 5580MHz

Horizontal

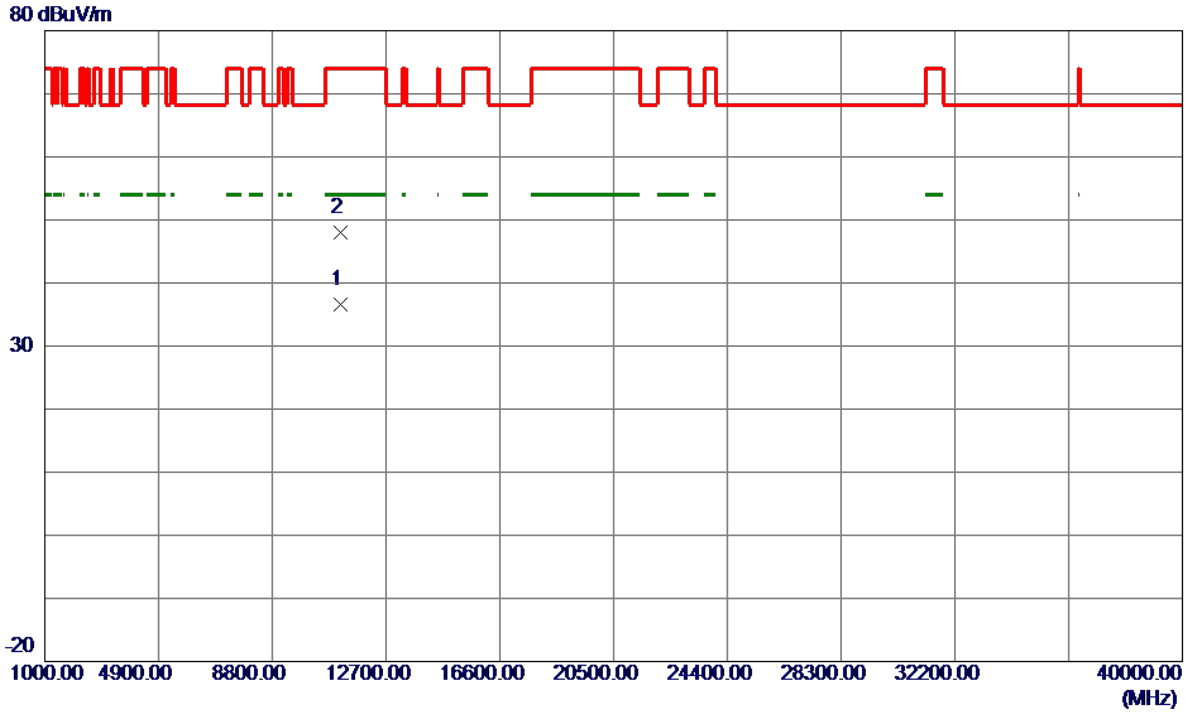

No.	Freq. MHz	Reading Level dBuV/m	Correct Factor dB	Measure ment dBuV/m	Limit dBuV/m	Margin dB	Detector	Comment
1 *	11158.1600	21.06	15.60	36.66	54.00	-17.34	AVG	
2	11159.5700	32.38	15.60	47.98	74.00	-26.02	Peak	

Orthogonal Axis :	X
Test Mode :	UNII-2C/ TX A Mode 5700MHz

Vertical

130 dBuV/m

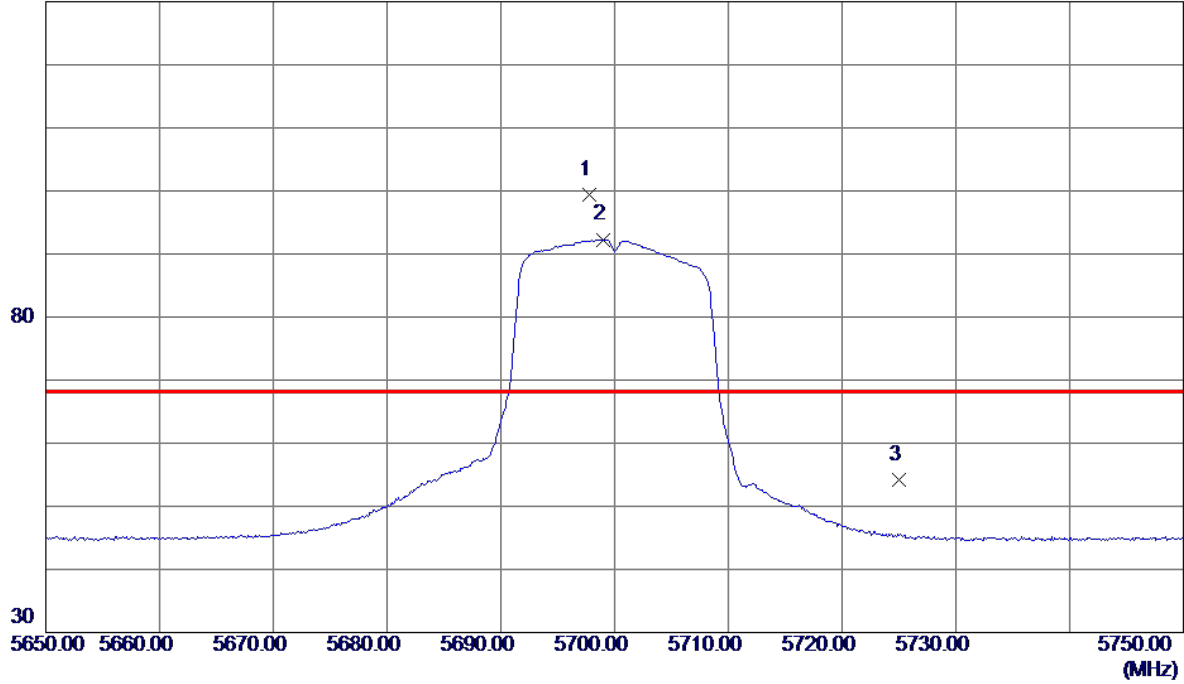

No.	Freq. MHz	Reading Level dBuV/m	Correct Factor dB	Measure ment dBuV/m	Limit dBuV/m	Margin dB	Detector	Comment
1 *	5697.8000	81.03	18.34	99.37	68.30	31.07	Peak	No Limit
2	5699.0000	73.96	18.34	92.30	999.00	-906.70	AVG	No Limit
3	5725.0000	35.76	18.44	54.20	68.30	-14.10	Peak	

Orthogonal Axis :	X
Test Mode :	UNII-2C/ TX A Mode 5700MHz

Vertical

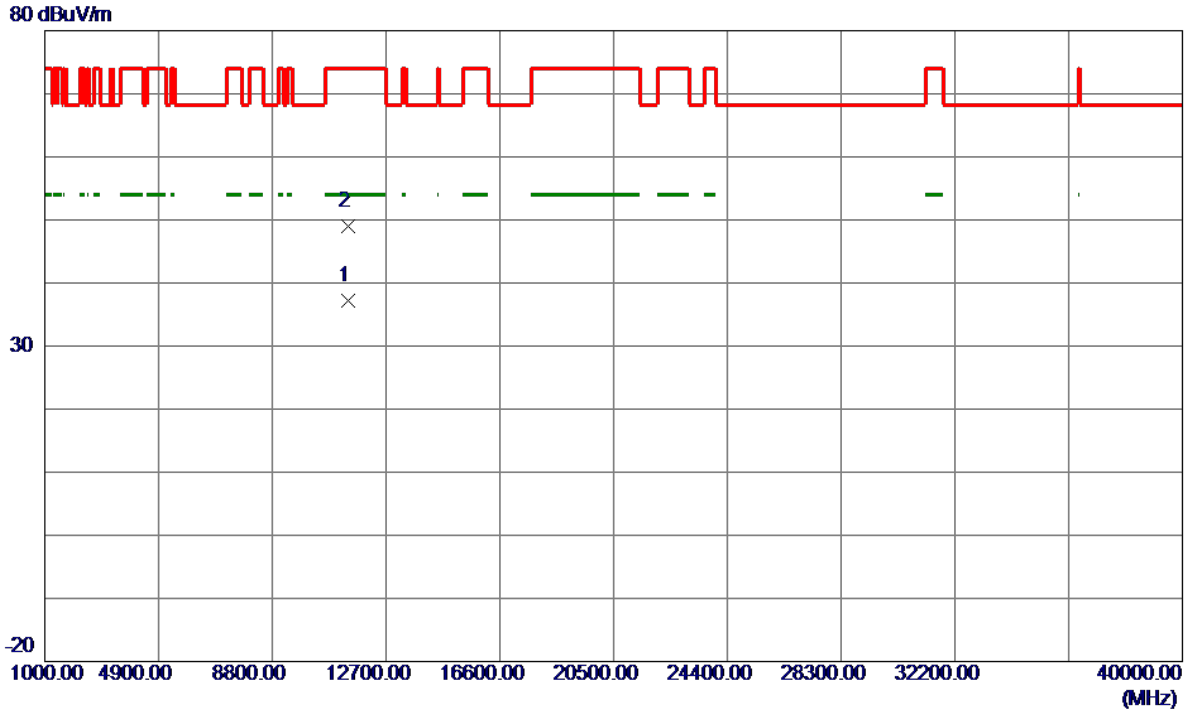

No.	Freq. MHz	Reading Level dBuV/m	Correct Factor dB	Measure ment dBuV/m	Limit dBuV/m	Margin dB	Detector	Comment
1 *	11399.4750	21.28	15.85	37.13	54.00	-16.87	AVG	
2	11401.3099	33.11	15.85	48.96	74.00	-25.04	Peak	

Orthogonal Axis :	X
Test Mode :	UNII-2C/ TX A Mode 5700MHz

Horizontal

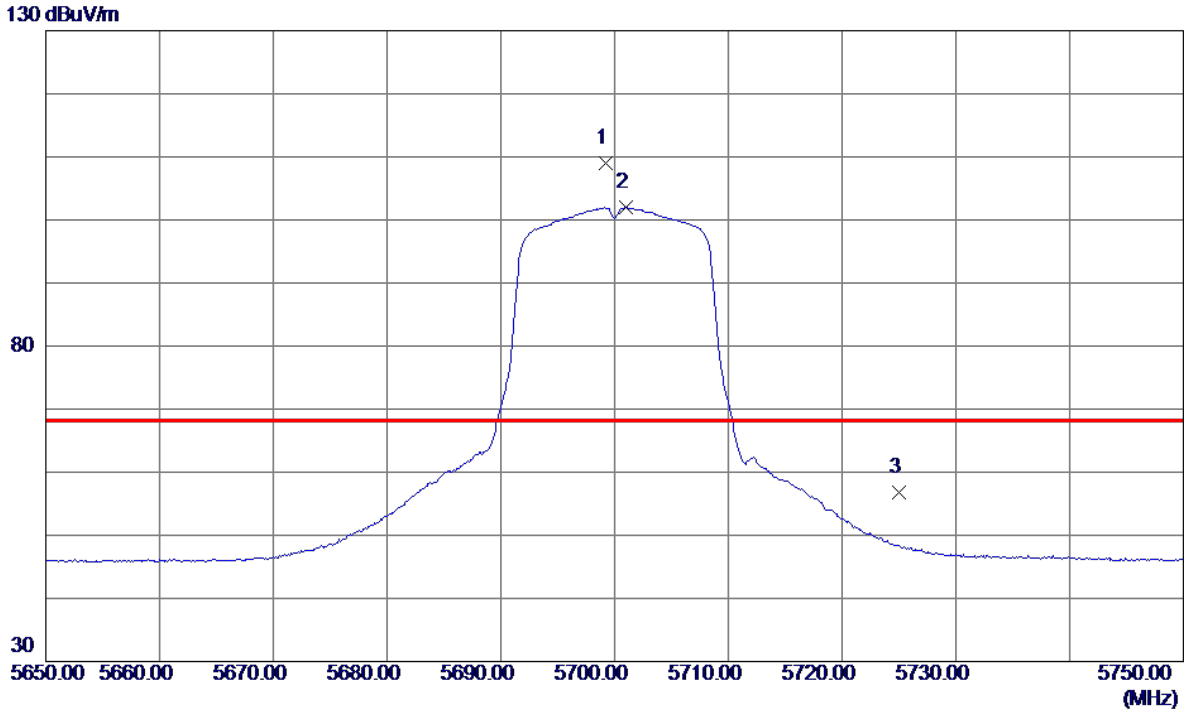

No.	Freq. MHz	Reading Level dBuV/m	Correct Factor dB	Measure ment dBuV/m	Limit dBuV/m	Margin dB	Detector	Comment
1 *	5699.2000	90.69	18.35	109.04	68.30	40.74	Peak	No Limit
2	5701.0000	83.63	18.35	101.98	999.00	-897.02	AVG	No Limit
3	5725.0000	38.38	18.44	56.82	68.30	-11.48	Peak	

Orthogonal Axis :	X
Test Mode :	UNII-2C/ TX A Mode 5700MHz

Horizontal

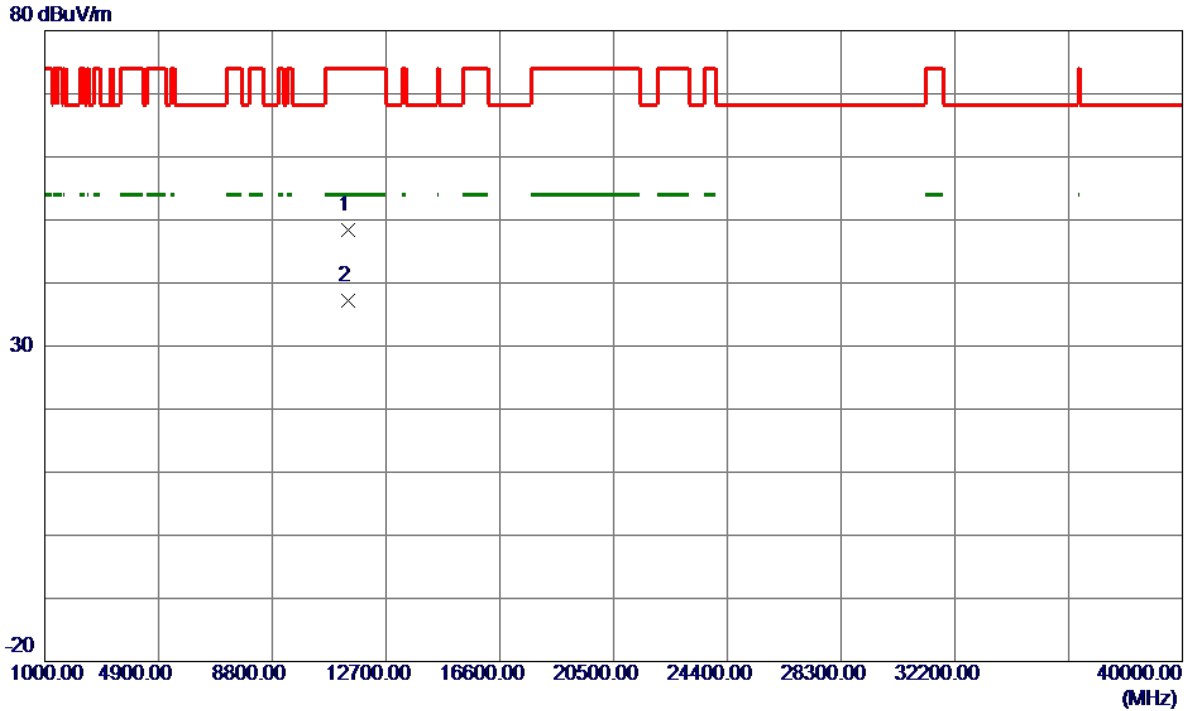

No.	Freq. MHz	Reading Level dBuV/m	Correct Factor dB	Measure ment dBuV/m	Limit dBuV/m	Margin dB	Detector	Comment
1	11401.9000	32.59	15.85	48.44	74.00	-25.56	Peak	
2 *	11402.0550	21.32	15.85	37.17	54.00	-16.83	AVG	

Orthogonal Axis :	X
Test Mode :	UNII-2C/ TX N20 Mode 5500MHz

Vertical

130 dBuV/m

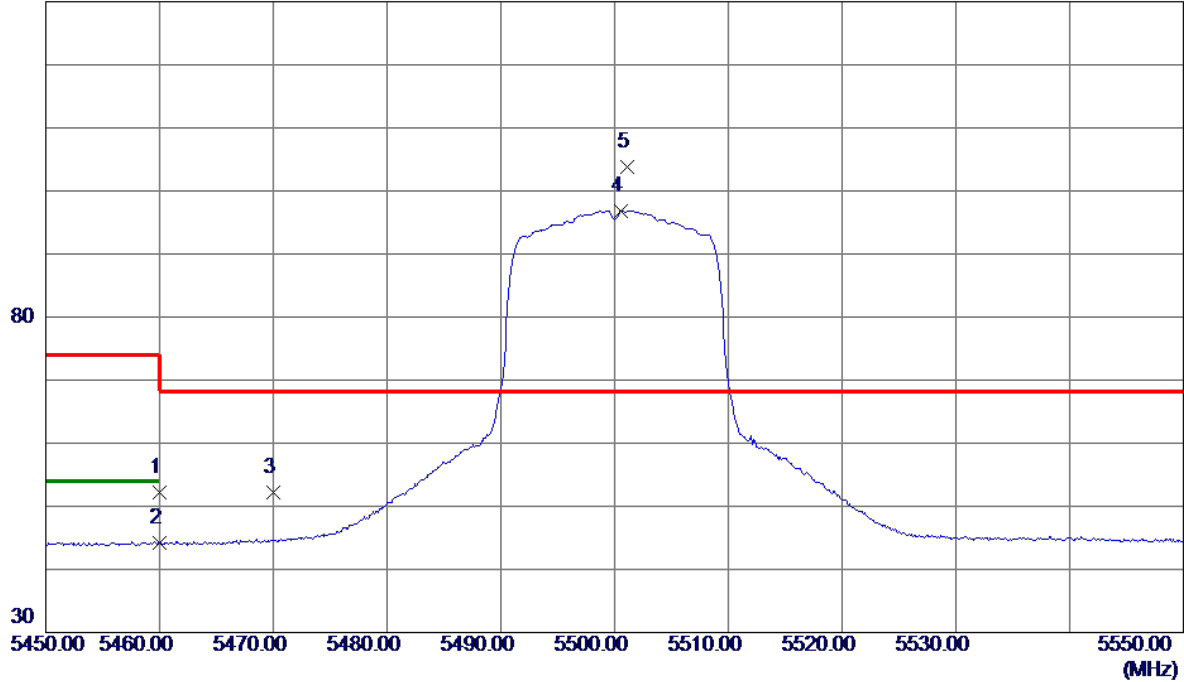

No.	Freq. MHz	Reading Level dBuV/m	Correct Factor dB	Measure ment dBuV/m	Limit dBuV/m	Margin dB	Detector	Comment
1	5460.0000	34.75	17.53	52.28	74.00	-21.72	Peak	
2	5460.0000	26.62	17.53	44.15	54.00	-9.85	AVG	
3	5470.0000	34.57	17.55	52.12	68.30	-16.18	Peak	
4	5500.6000	79.22	17.64	96.86	999.00	-902.14	AVG	No Limit
5 *	5501.1000	86.14	17.64	103.78	68.30	35.48	Peak	No Limit

Orthogonal Axis :	X
Test Mode :	UNII-2C/ TX N20 Mode 5500MHz

Vertical



No.	Freq. MHz	Reading Level dBuV/m	Correct Factor dB	Measure ment dBuV/m	Limit dBuV/m	Margin dB	Detector	Comment
1 *	10999.7900	21.19	15.43	36.62	54.00	-17.38	AVG	
2	11001.0950	31.98	15.43	47.41	74.00	-26.59	Peak	

Orthogonal Axis :	X
Test Mode :	UNII-2C/ TX N20 Mode 5500MHz

Horizontal

130 dBuV/m

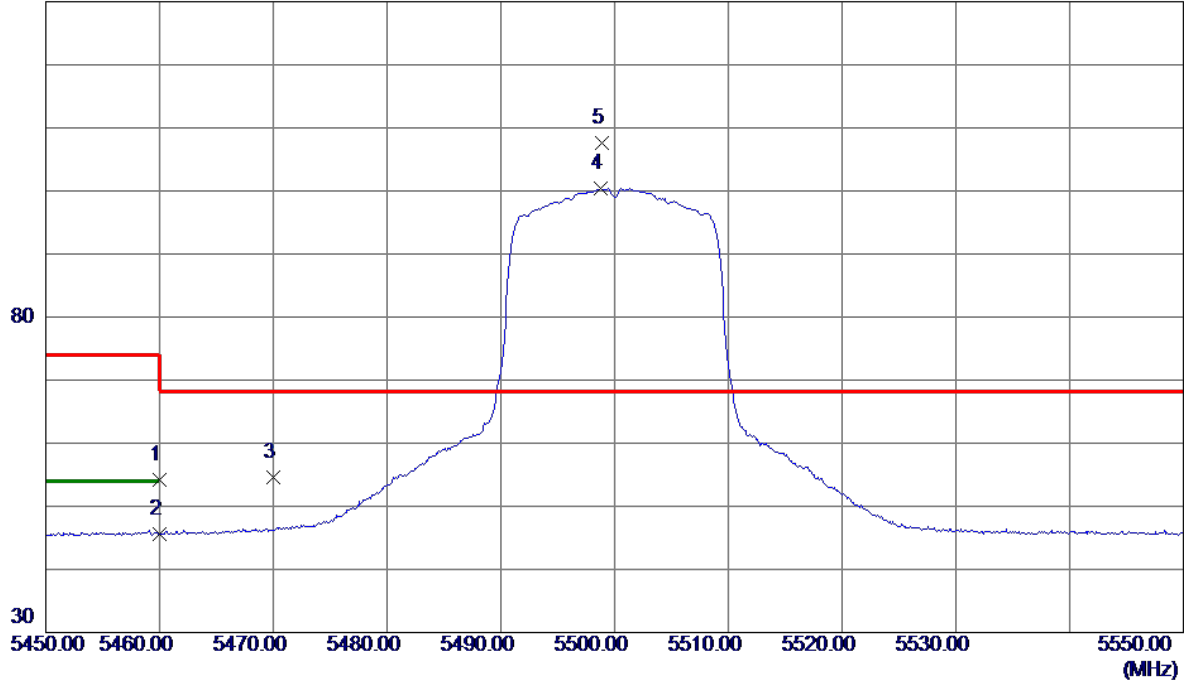

No.	Freq. MHz	Reading Level dBuV/m	Correct Factor dB	Measure ment dBuV/m	Limit dBuV/m	Margin dB	Detector	Comment
1	5460.0000	36.76	17.53	54.29	74.00	-19.71	Peak	
2	5460.0000	28.03	17.53	45.56	54.00	-8.44	AVG	
3	5470.0000	36.97	17.55	54.52	68.30	-13.78	Peak	
4	5498.8000	82.71	17.64	100.35	999.00	-898.65	AVG	No Limit
5 *	5498.9000	89.91	17.64	107.55	68.30	39.25	Peak	No Limit

Orthogonal Axis :	X
Test Mode :	UNII-2C/ TX N20 Mode 5500MHz

Horizontal

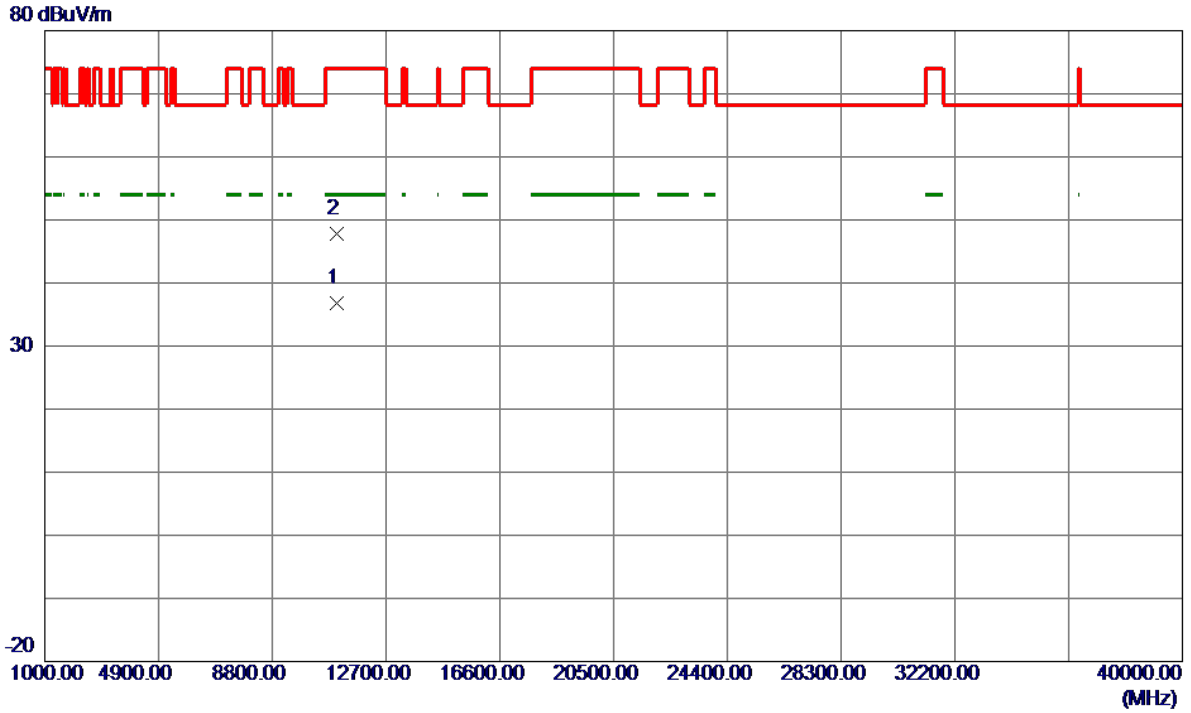

No.	Freq. MHz	Reading Level dBuV/m	Correct Factor dB	Measure ment dBuV/m	Limit dBuV/m	Margin dB	Detector	Comment
1 *	10998.5700	21.33	15.43	36.76	54.00	-17.24	AVG	
2	11000.0550	32.31	15.43	47.74	74.00	-26.26	Peak	

Orthogonal Axis :	X
Test Mode :	UNII-2C/ TX N20 Mode 5580MHz

Vertical

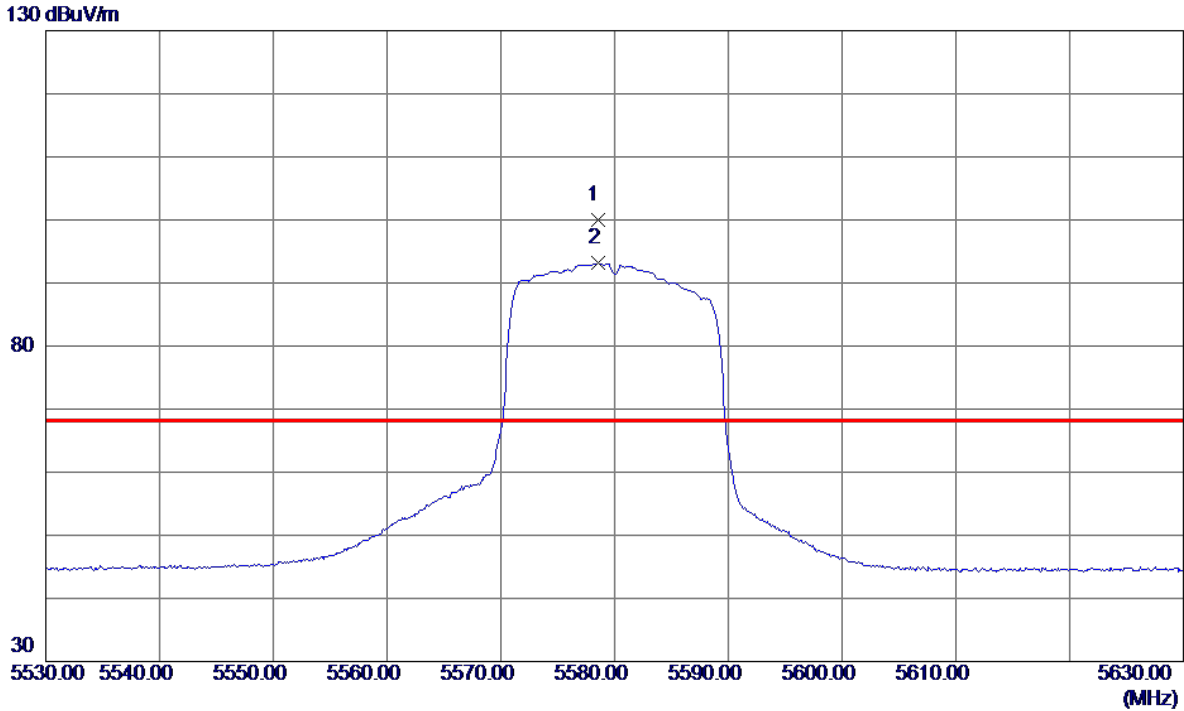

No.	Freq. MHz	Reading Level dBuV/m	Correct Factor dB	Measure ment dBuV/m	Limit dBuV/m	Margin dB	Detector	Comment
1 *	5578.5000	82.02	17.92	99.94	68.30	31.64	Peak	No Limit
2	5578.6000	75.20	17.92	93.12	999.00	-905.88	AVG	No Limit

Orthogonal Axis :	X
Test Mode :	UNII-2C/ TX N20 Mode 5580MHz

Vertical

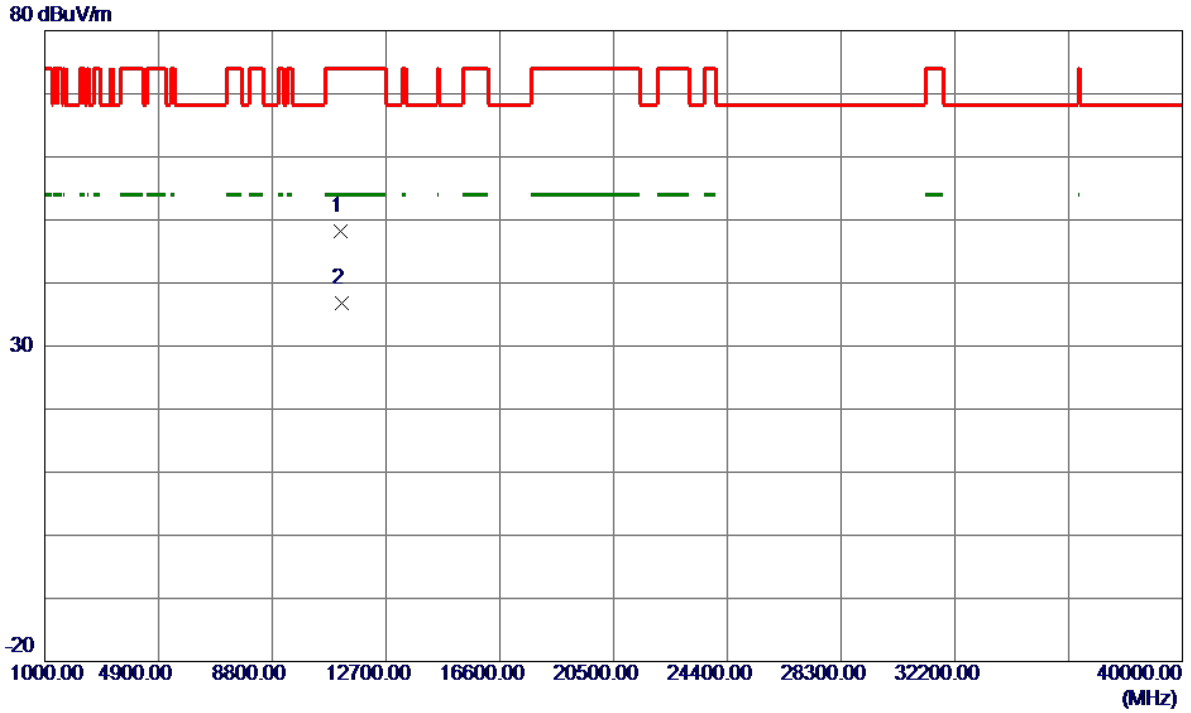

No.	Freq. MHz	Reading Level dBuV/m	Correct Factor dB	Measure ment dBuV/m	Limit dBuV/m	Margin dB	Detector	Comment
1	11160.2950	32.61	15.60	48.21	74.00	-25.79	Peak	
2 *	11161.9349	21.29	15.60	36.89	54.00	-17.11	AVG	

Orthogonal Axis :	X
Test Mode :	UNII-2C/ TX N20 Mode 5580MHz

Horizontal

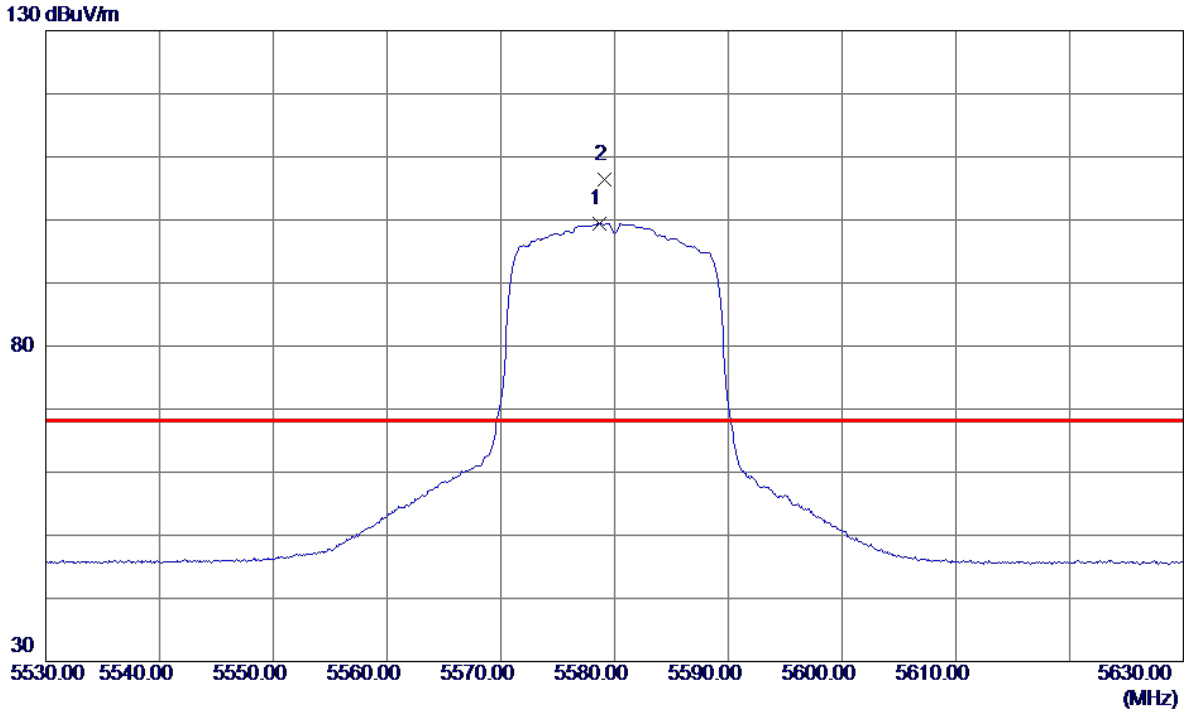

No.	Freq. MHz	Reading Level dBuV/m	Correct Factor dB	Measure ment dBuV/m	Limit dBuV/m	Margin dB	Detector	Comment
1	5578.7000	81.51	17.92	99.43	999.00	-899.57	AVG	No Limit
2 *	5579.1000	88.56	17.92	106.48	68.30	38.18	Peak	No Limit

Orthogonal Axis :	X
Test Mode :	UNII-2C/ TX N20 Mode 5580MHz

Horizontal

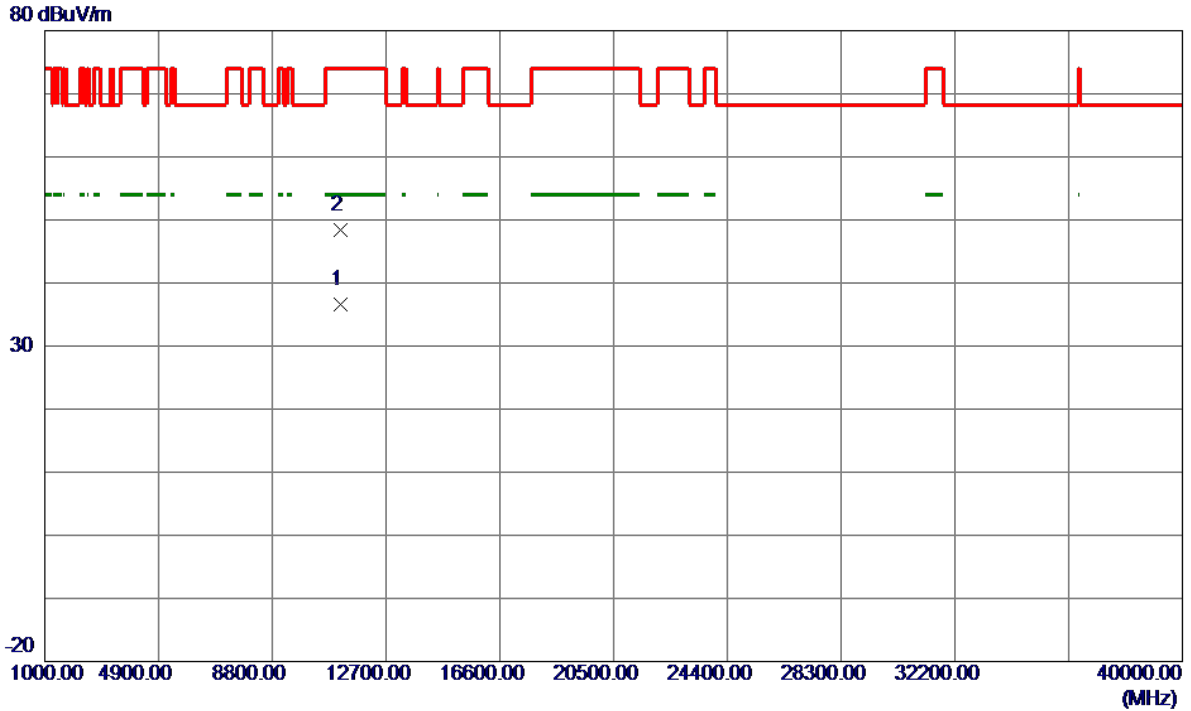

No.	Freq. MHz	Reading Level dBuV/m	Correct Factor dB	Measure ment dBuV/m	Limit dBuV/m	Margin dB	Detector	Comment
1 *	11157.6150	21.04	15.60	36.64	54.00	-17.36	AVG	
2	11159.1200	32.82	15.60	48.42	74.00	-25.58	Peak	

Orthogonal Axis :	X
Test Mode :	UNII-2C/ TX N20 Mode 5700MHz

Vertical

130 dBuV/m

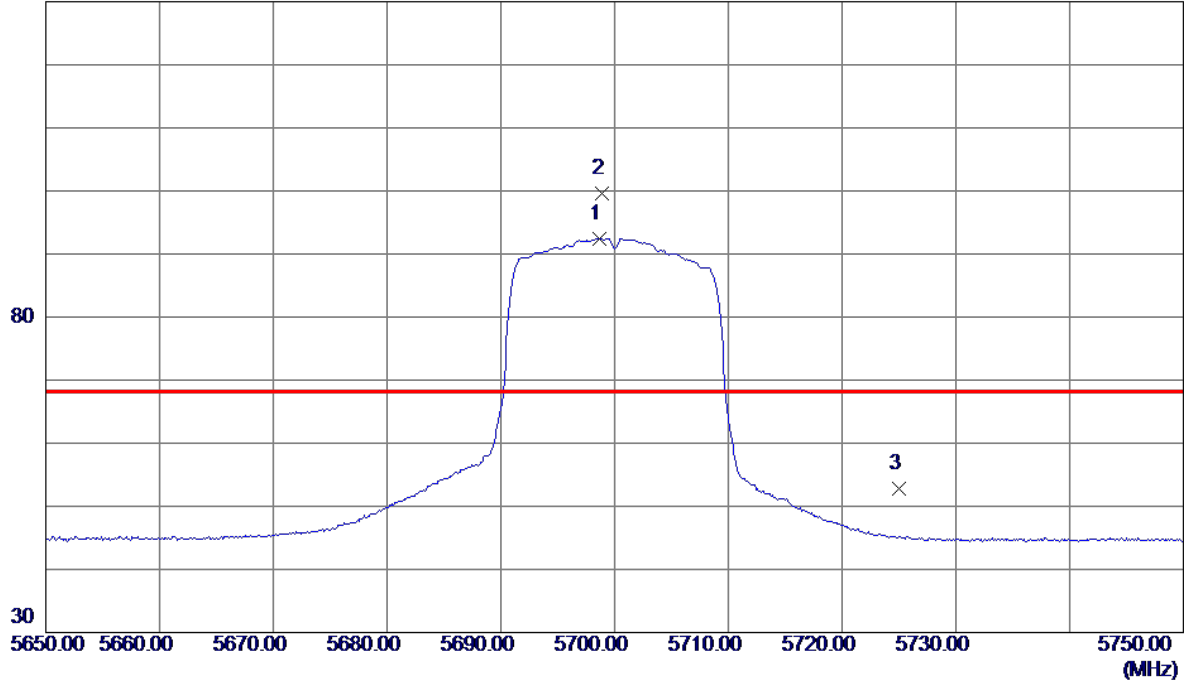

No.	Freq. MHz	Reading Level dBuV/m	Correct Factor dB	Measure ment dBuV/m	Limit dBuV/m	Margin dB	Detector	Comment
1	5698.7000	74.15	18.34	92.49	999.00	-906.51	AVG	No Limit
2 *	5698.9000	81.31	18.34	99.65	68.30	31.35	Peak	No Limit
3	5725.0000	34.38	18.44	52.82	68.30	-15.48	Peak	

Orthogonal Axis :	X
Test Mode :	UNII-2C/ TX N20 Mode 5700MHz

Vertical

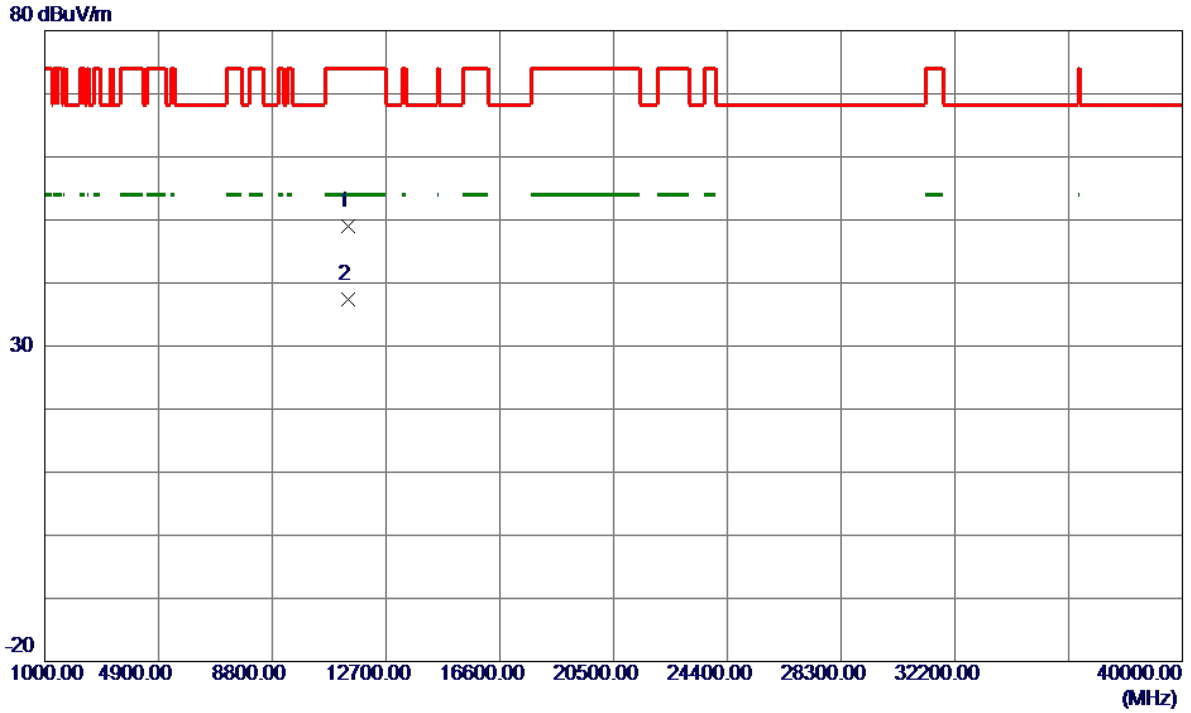

No.	Freq. MHz	Reading Level dBuV/m	Correct Factor dB	Measure ment dBuV/m	Limit dBuV/m	Margin dB	Detector	Comment
1	11398.0350	33.06	15.85	48.91	74.00	-25.09	Peak	
2 *	11400.7450	21.49	15.85	37.34	54.00	-16.66	AVG	

Orthogonal Axis :	X
Test Mode :	UNII-2C/ TX N20 Mode 5700MHz

Horizontal

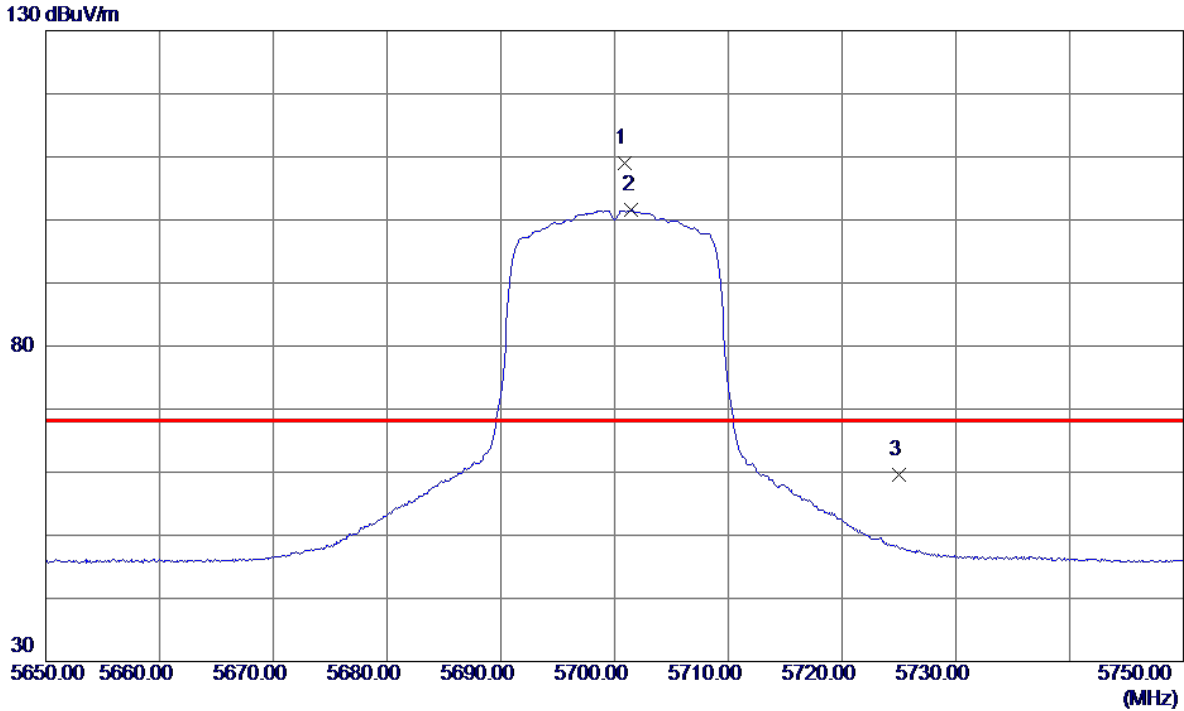

No.	Freq. MHz	Reading Level dBuV/m	Correct Factor dB	Measure ment dBuV/m	Limit dBuV/m	Margin dB	Detector	Comment
1 *	5700.9000	90.61	18.35	108.96	68.30	40.66	Peak	No Limit
2	5701.5000	83.18	18.35	101.53	999.00	-897.47	AVG	No Limit
3	5725.0000	41.25	18.44	59.69	68.30	-8.61	Peak	

Orthogonal Axis :	X
Test Mode :	UNII-2C/ TX N20 Mode 5700MHz

Horizontal



No.	Freq. MHz	Reading Level dBuV/m	Correct Factor dB	Measure ment dBuV/m	Limit dBuV/m	Margin dB	Detector	Comment
1 *	11399.4250	21.38	15.85	37.23	54.00	-16.77	AVG	
2	11400.9250	32.89	15.85	48.74	74.00	-25.26	Peak	

Orthogonal Axis :	X
Test Mode :	UNII-2C/ TX N40 Mode 5510MHz

Vertical

130 dBuV/m

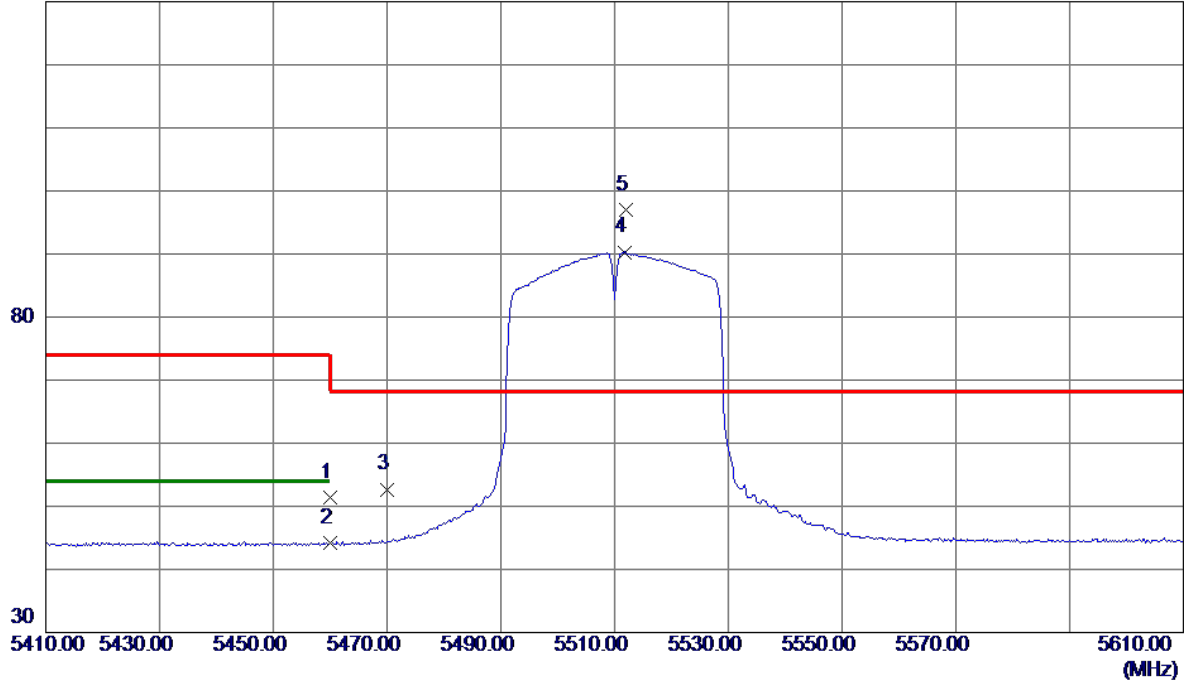

No.	Freq. MHz	Reading Level dBuV/m	Correct Factor dB	Measure ment dBuV/m	Limit dBuV/m	Margin dB	Detector	Comment
1	5460.0000	33.81	17.53	51.34	74.00	-22.66	Peak	
2	5460.0000	26.61	17.53	44.14	54.00	-9.86	AVG	
3	5470.0000	35.15	17.55	52.70	68.30	-15.60	Peak	
4	5511.8000	72.62	17.68	90.30	999.00	-908.70	AVG	No Limit
5 *	5512.0000	79.33	17.68	97.01	68.30	28.71	Peak	No Limit

Orthogonal Axis :	X
Test Mode :	UNII-2C/ TX N40 Mode 5510MHz

Vertical

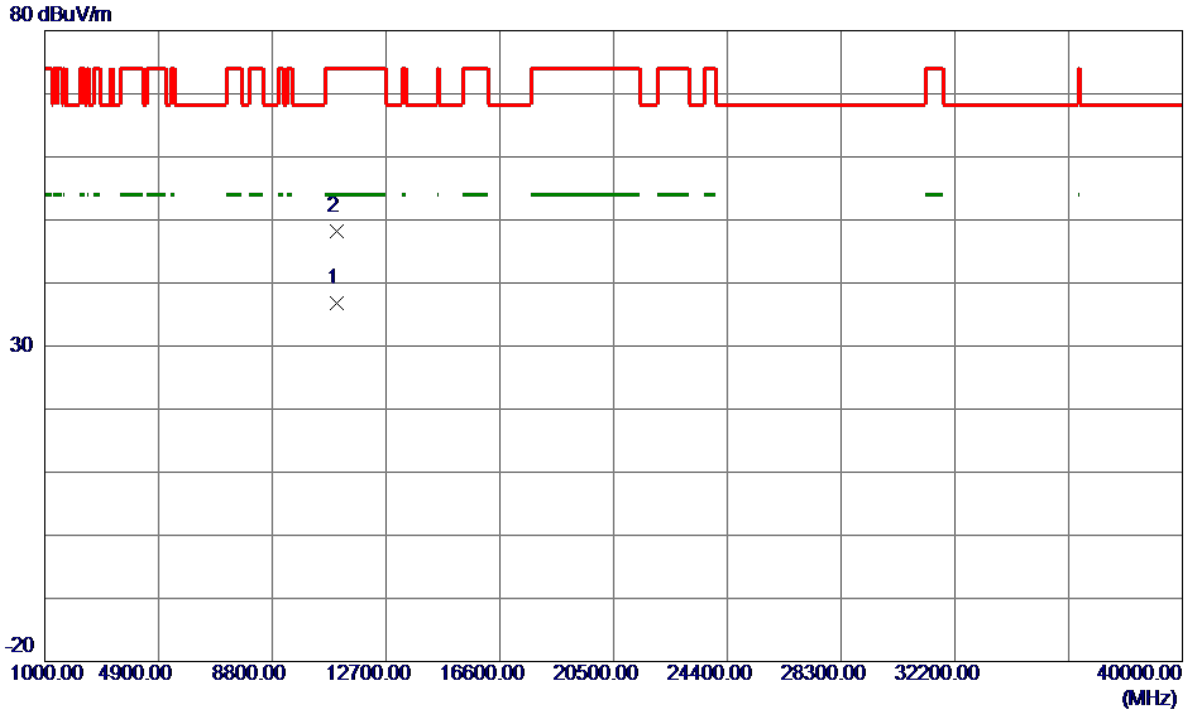

No.	Freq. MHz	Reading Level dBuV/m	Correct Factor dB	Measure ment dBuV/m	Limit dBuV/m	Margin dB	Detector	Comment
1 *	11022.2900	21.40	15.45	36.85	54.00	-17.15	AVG	
2	11022.3850	32.69	15.45	48.14	74.00	-25.86	Peak	

Orthogonal Axis :	X
Test Mode :	UNII-2C/ TX N40 Mode 5510MHz

Horizontal

130 dBuV/m

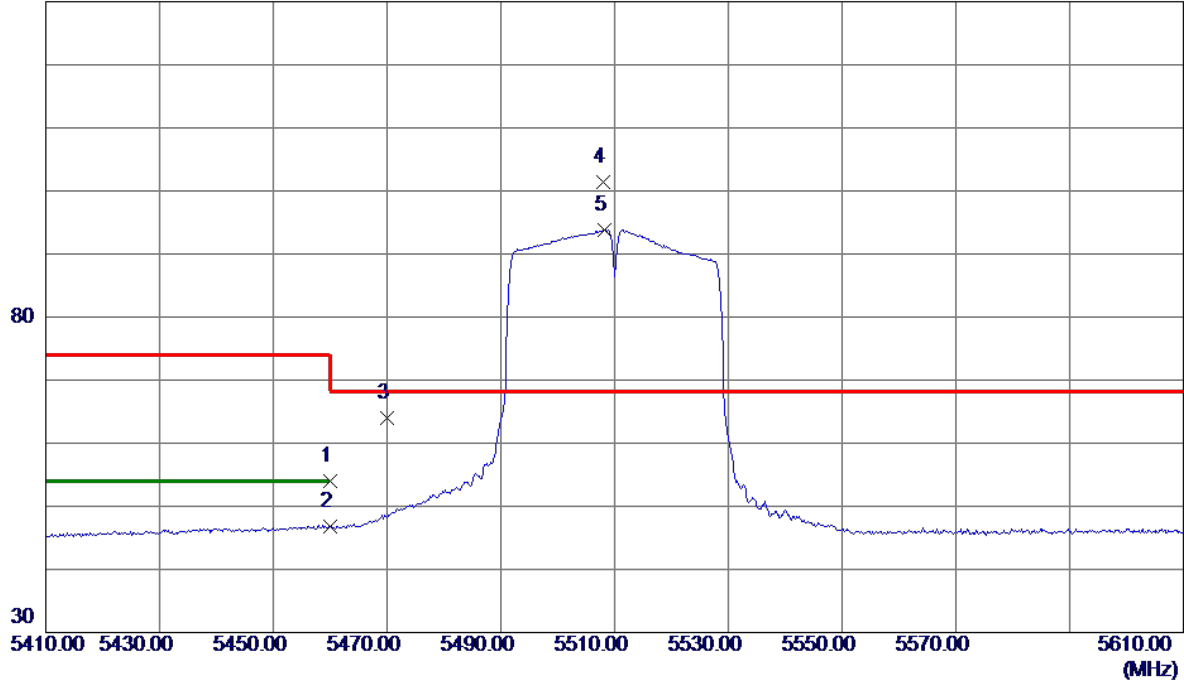

No.	Freq. MHz	Reading Level dBuV/m	Correct Factor dB	Measure ment dBuV/m	Limit dBuV/m	Margin dB	Detector	Comment
1	5460.0000	36.53	17.53	54.06	74.00	-19.94	Peak	
2	5460.0000	29.22	17.53	46.75	54.00	-7.25	AVG	
3	5470.0000	46.39	17.55	63.94	68.30	-4.36	Peak	
4 *	5508.0000	83.67	17.67	101.34	68.30	33.04	Peak	No Limit
5	5508.2000	76.20	17.67	93.87	999.00	-905.13	AVG	No Limit

Orthogonal Axis :	X
Test Mode :	UNII-2C/ TX N40 Mode 5510MHz

Horizontal

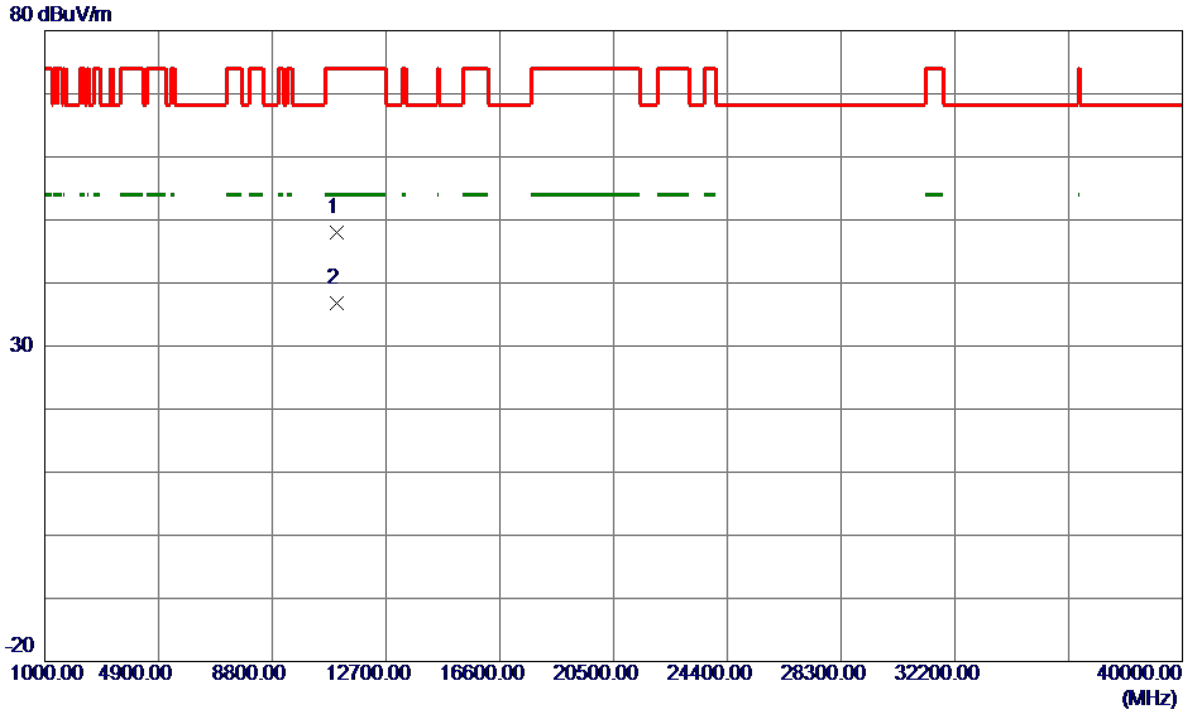

No.	Freq. MHz	Reading Level dBuV/m	Correct Factor dB	Measure ment dBuV/m	Limit dBuV/m	Margin dB	Detector	Comment
1	11019.0050	32.60	15.45	48.05	74.00	-25.95	Peak	
2 *	11019.8750	21.36	15.45	36.81	54.00	-17.19	AVG	

Orthogonal Axis :	X
Test Mode :	UNII-2C/ TX N40 Mode 5550MHz

Vertical

130 dBuV/m

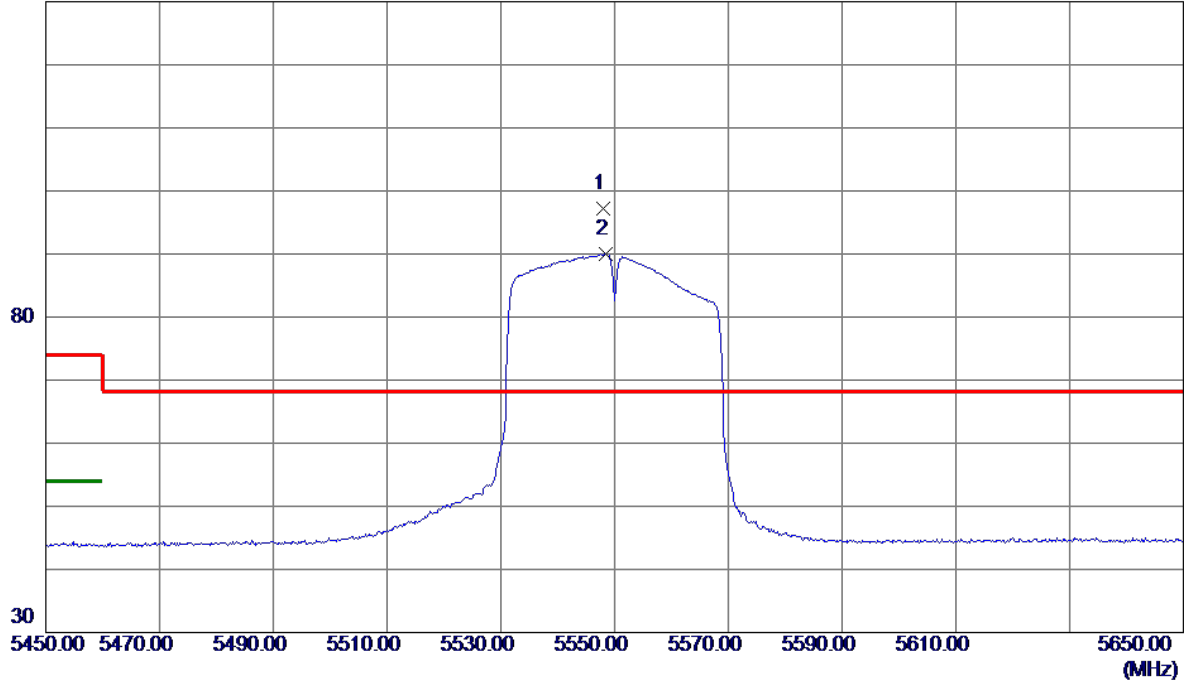

No.	Freq. MHz	Reading Level dBuV/m	Correct Factor dB	Measure ment dBuV/m	Limit dBuV/m	Margin dB	Detector	Comment
1 *	5548.0000	79.42	17.81	97.23	68.30	28.93	Peak	No Limit
2	5548.4000	72.15	17.81	89.96	999.00	-909.04	AVG	No Limit

Orthogonal Axis :	X
Test Mode :	UNII-2C/ TX N40 Mode 5550MHz

Vertical

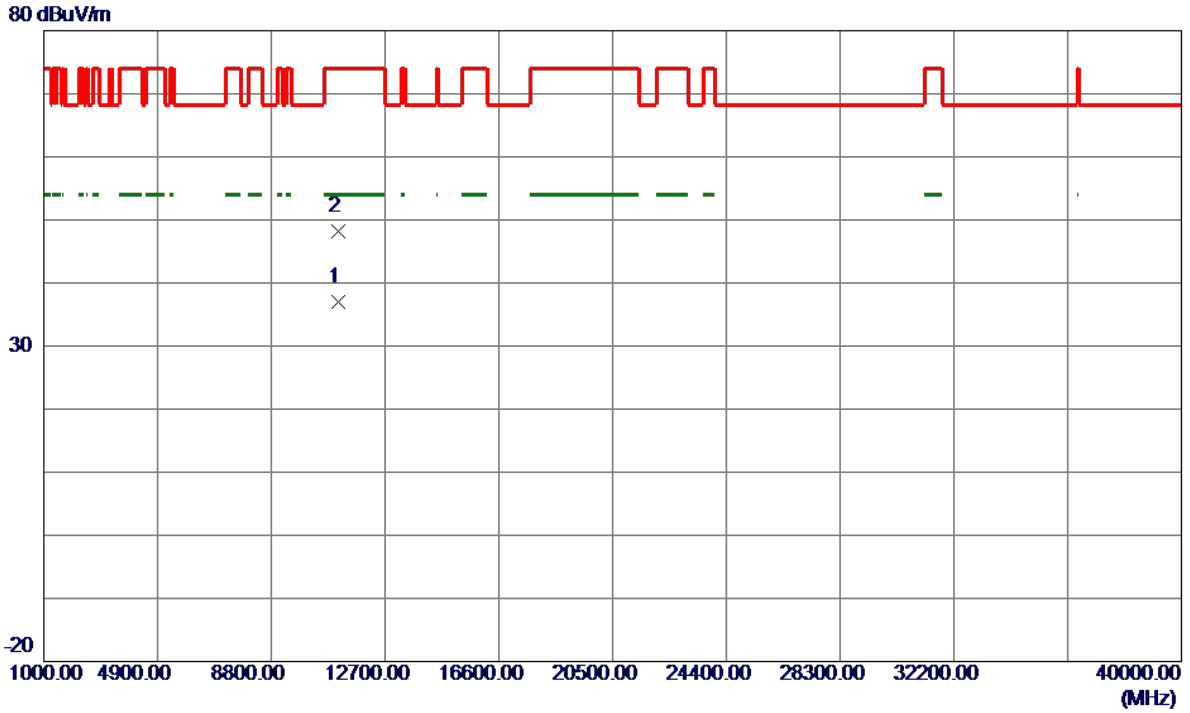

No.	Freq. MHz	Reading Level dBuV/m	Correct Factor dB	Measure ment dBuV/m	Limit dBuV/m	Margin dB	Detector	Comment
1 *	11098.5800	21.50	15.53	37.03	54.00	-16.97	AVG	
2	11101.5850	32.57	15.54	48.11	74.00	-25.89	Peak	

Orthogonal Axis :	X
Test Mode :	UNII-2C/ TX N40 Mode 5550MHz

Horizontal

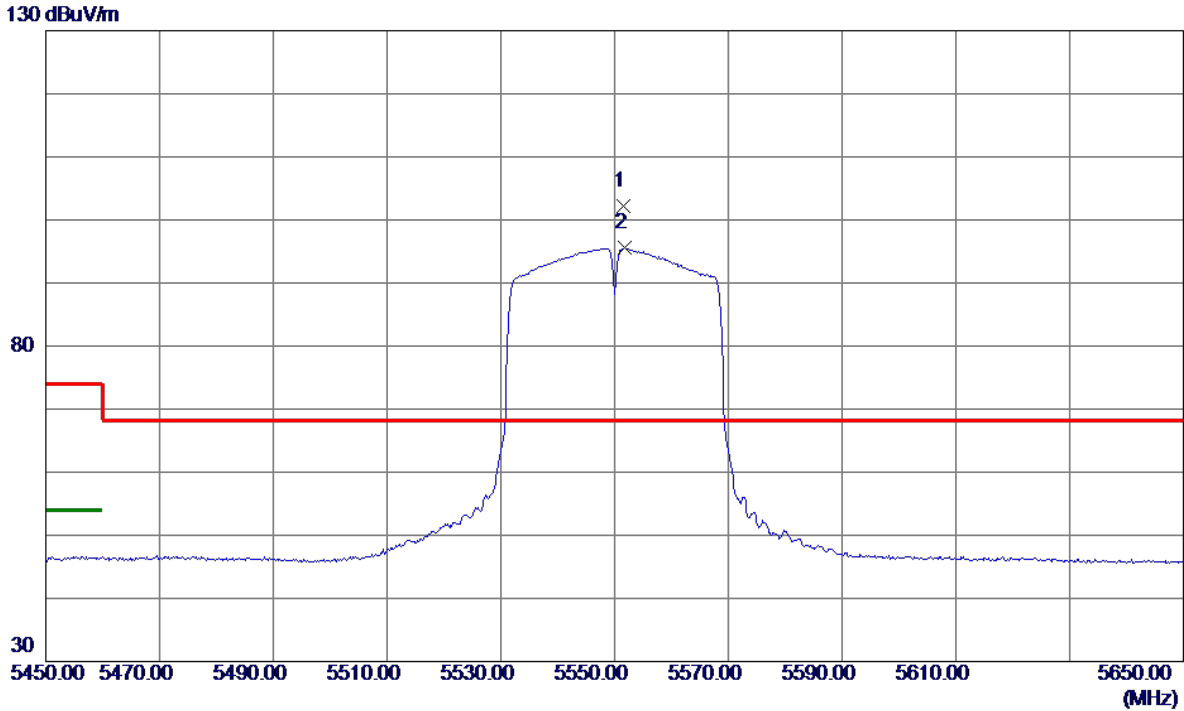

No.	Freq. MHz	Reading Level dBuV/m	Correct Factor dB	Measure ment dBuV/m	Limit dBuV/m	Margin dB	Detector	Comment
1 *	5551.6000	84.43	17.82	102.25	68.30	33.95	Peak	No Limit
2	5551.8000	77.73	17.82	95.55	999.00	-903.45	AVG	No Limit

Orthogonal Axis :	X
Test Mode :	UNII-2C/ TX N40 Mode 5550MHz

Horizontal

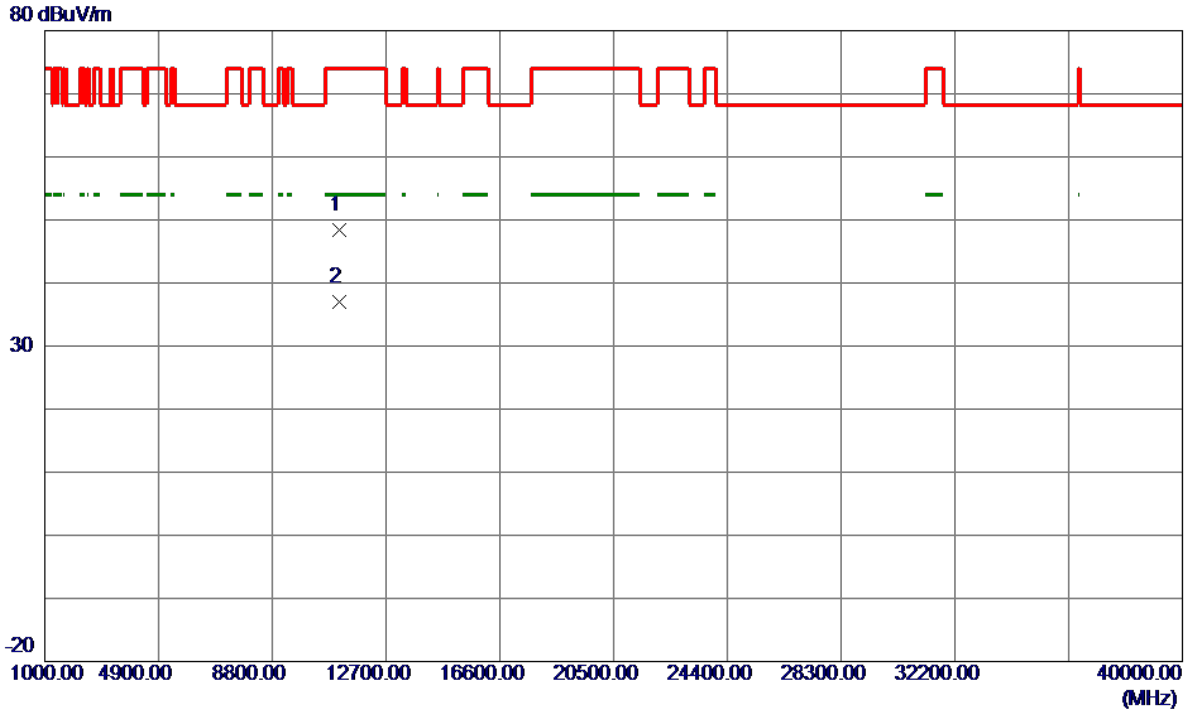

No.	Freq. MHz	Reading Level dBuV/m	Correct Factor dB	Measure ment dBuV/m	Limit dBuV/m	Margin dB	Detector	Comment
1	11100.4750	32.80	15.54	48.34	74.00	-25.66	Peak	
2 *	11101.1750	21.40	15.54	36.94	54.00	-17.06	AVG	

Orthogonal Axis :	X
Test Mode :	UNII-2C/ TX N40 Mode 5670MHz

Vertical

130 dBuV/m

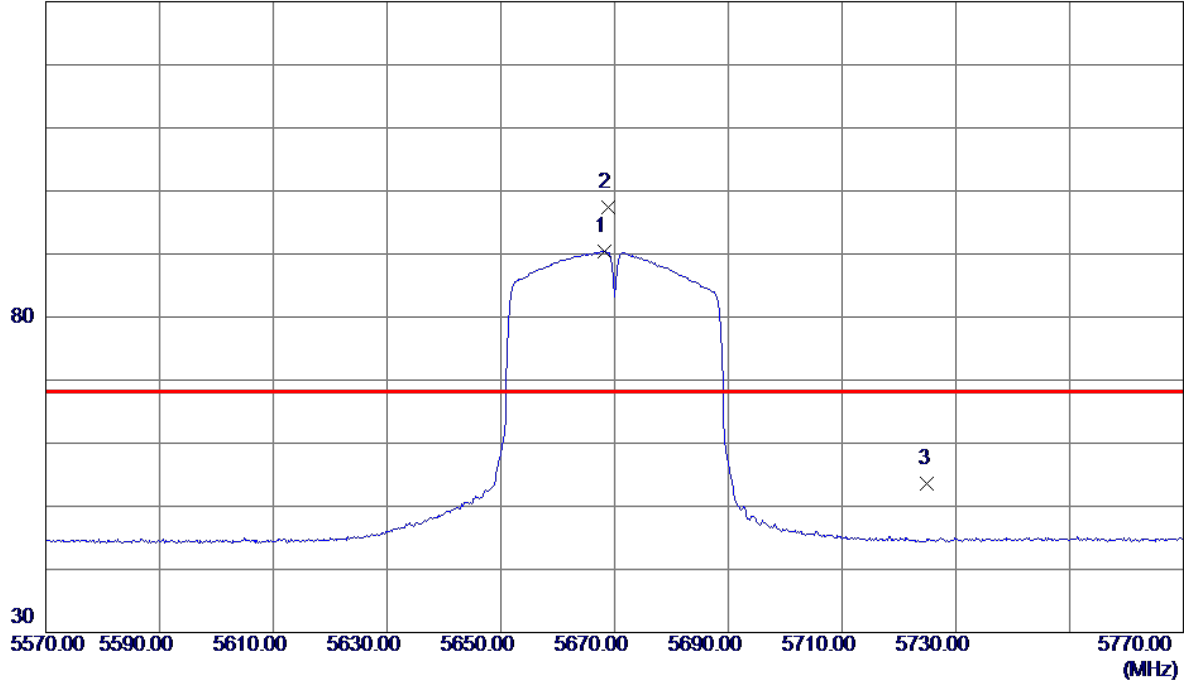

No.	Freq. MHz	Reading Level dBuV/m	Correct Factor dB	Measure ment dBuV/m	Limit dBuV/m	Margin dB	Detector	Comment
1	5668.2000	72.19	18.24	90.43	999.00	-908.57	AVG	No Limit
2 *	5668.8000	79.20	18.24	97.44	68.30	29.14	Peak	No Limit
3	5725.0000	35.12	18.44	53.56	68.30	-14.74	Peak	

Orthogonal Axis :	X
Test Mode :	UNII-2C/ TX N40 Mode 5670MHz

Vertical

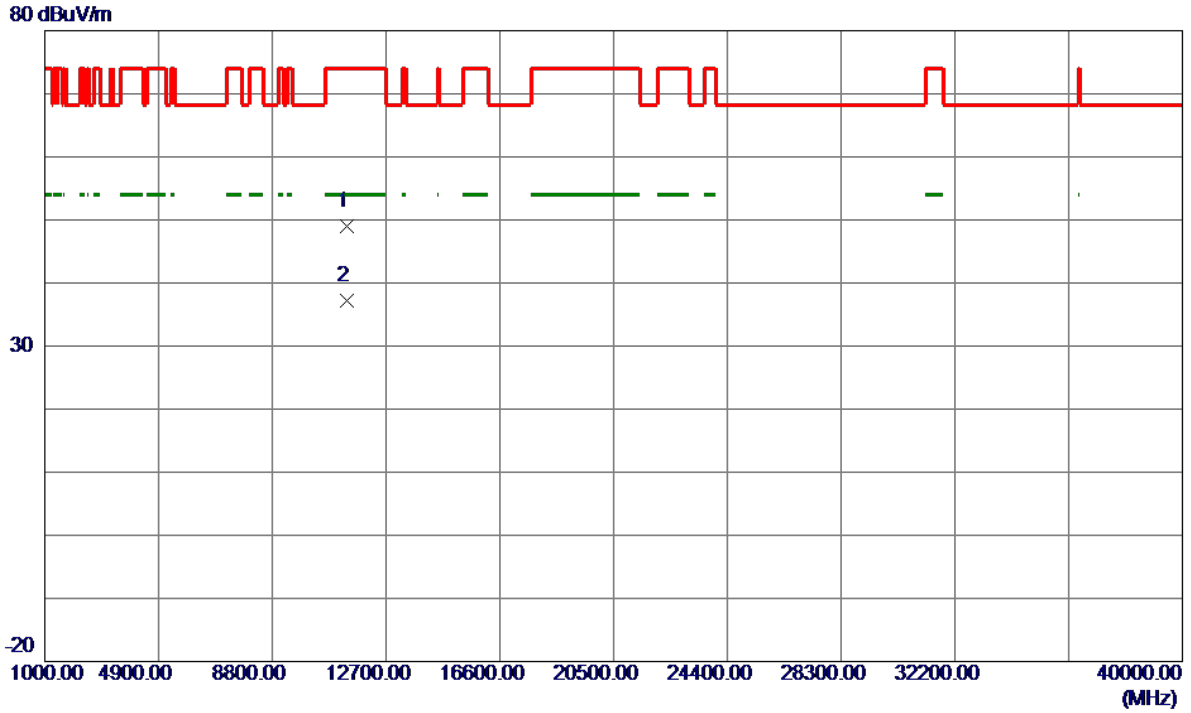

No.	Freq. MHz	Reading Level dBuV/m	Correct Factor dB	Measure ment dBuV/m	Limit dBuV/m	Margin dB	Detector	Comment
1	11338.1050	33.13	15.78	48.91	74.00	-25.09	Peak	
2 *	11340.9250	21.34	15.79	37.13	54.00	-16.87	AVG	

Orthogonal Axis :	X
Test Mode :	UNII-2C/ TX N40 Mode 5670MHz

Horizontal

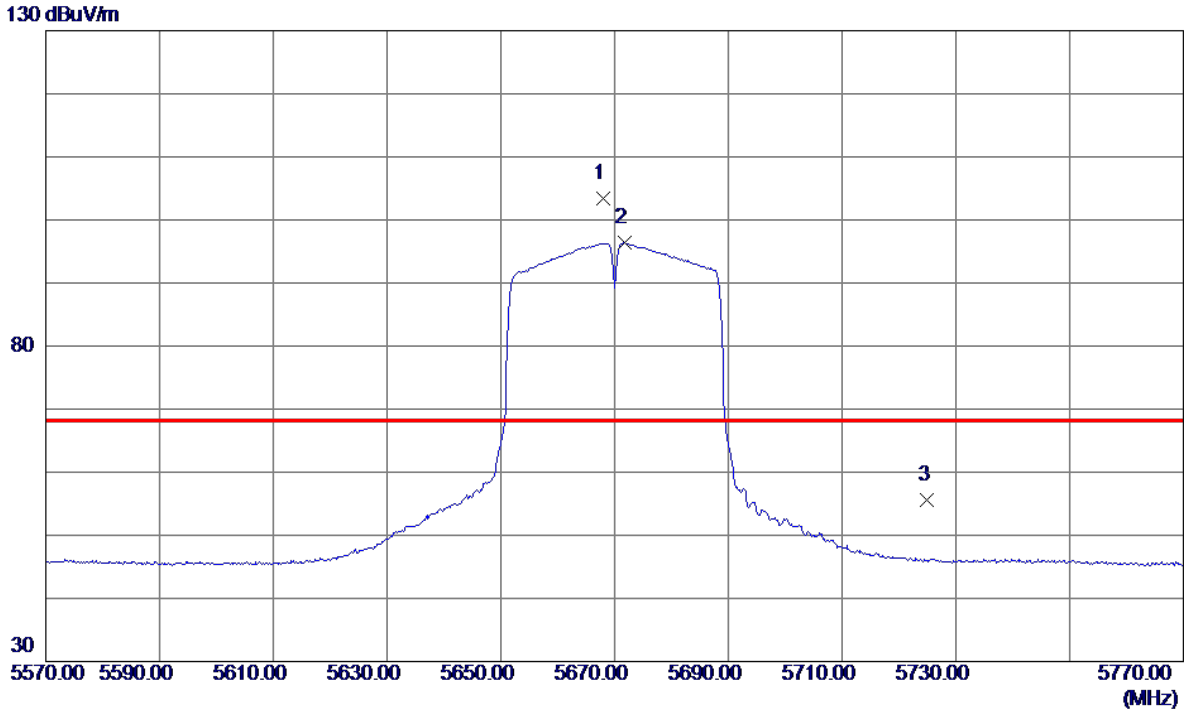

No.	Freq. MHz	Reading Level dBuV/m	Correct Factor dB	Measure ment dBuV/m	Limit dBuV/m	Margin dB	Detector	Comment
1 *	5668.0000	85.13	18.23	103.36	68.30	35.06	Peak	No Limit
2	5671.8000	78.12	18.25	96.37	999.00	-902.63	AVG	No Limit
3	5725.0000	37.17	18.44	55.61	68.30	-12.69	Peak	

Orthogonal Axis :	X
Test Mode :	UNII-2C/ TX N40 Mode 5670MHz

Horizontal

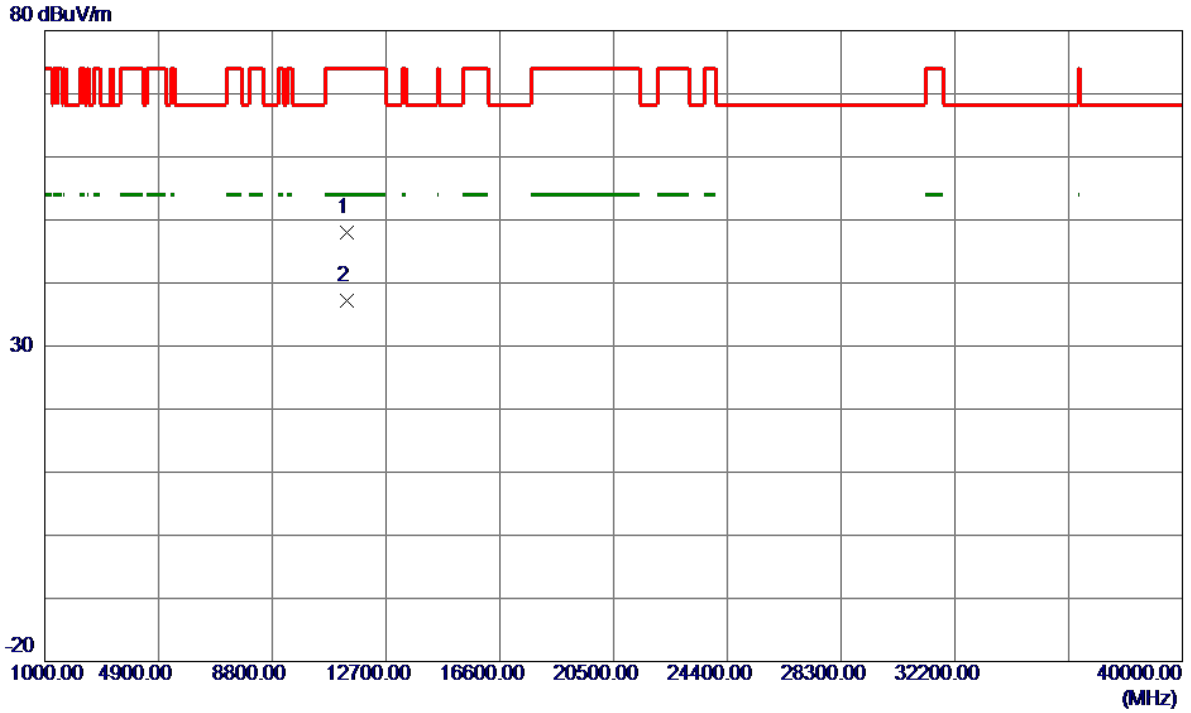

No.	Freq. MHz	Reading Level dBuV/m	Correct Factor dB	Measure ment dBuV/m	Limit dBuV/m	Margin dB	Detector	Comment
1 *	11338.9500	32.30	15.79	48.09	74.00	-25.91	Peak	
2	11342.4450	21.50	15.79	37.29	74.00	-36.71	Peak	

Orthogonal Axis:	X
Test Mode:	UNII-3/TX A Mode 5745MHz

Vertical

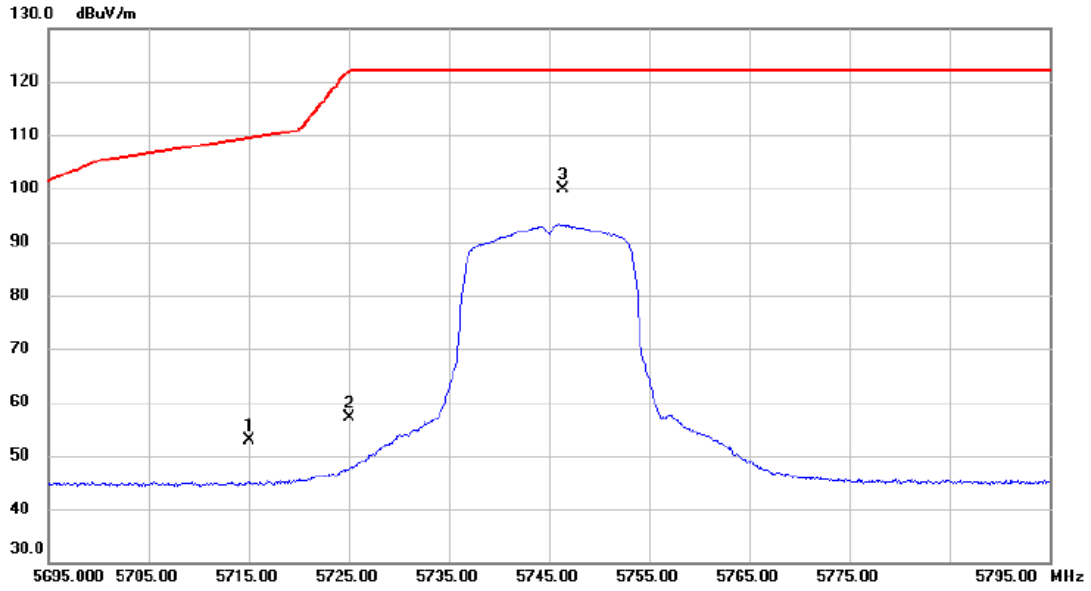

No.	Mk.	Freq. MHz	Reading Level dBuV	Correct Factor dB	Measure- ment dBuV/m	Limit dBuV/m	Margin dB	Detector	Comment
1		5715.000	34.48	18.40	52.88	109.40	-56.52	peak	
2		5725.000	38.69	18.43	57.12	122.20	-65.08	peak	
3	*	5746.400	81.33	18.51	99.84	122.20	-22.36	peak	

Orthogonal Axis:	X
Test Mode:	UNII-3/TX A Mode 5745MHz

Vertical

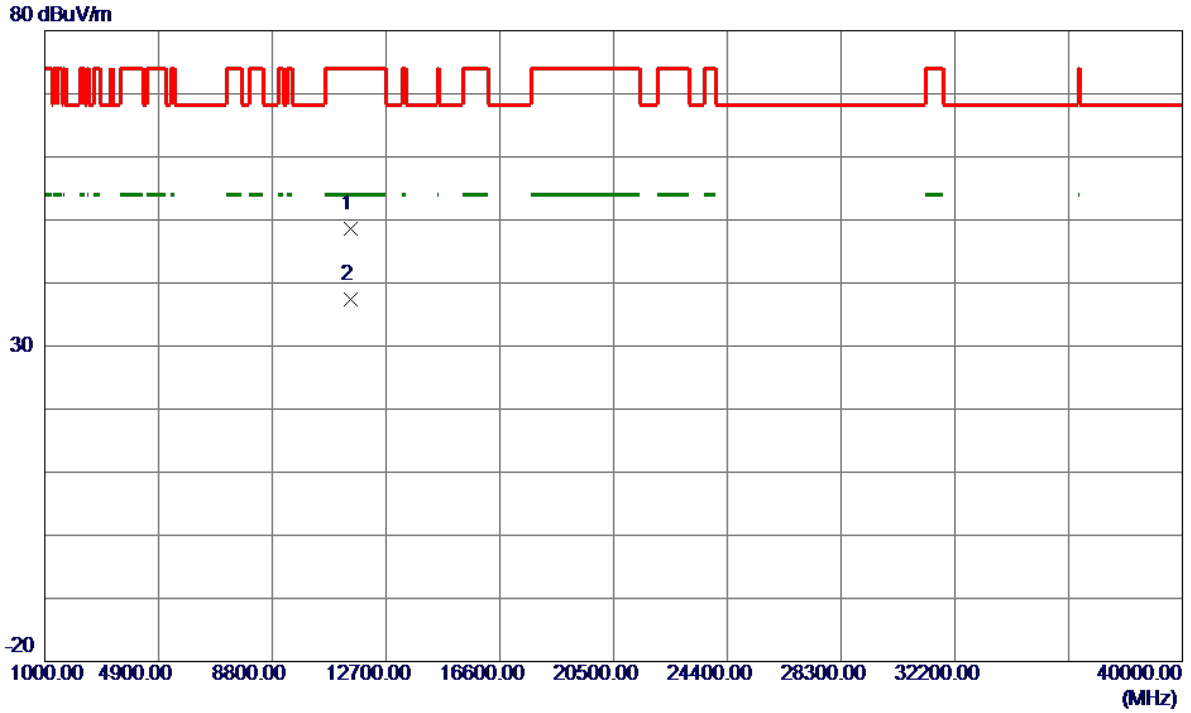

No.	Freq. MHz	Reading Level dBuV/m	Correct Factor dB	Measure ment dBuV/m	Limit dBuV/m	Margin dB	Detector	Comment
1	11489.7950	32.75	15.94	48.69	74.00	-25.31	Peak	
2 *	11490.8550	21.36	15.95	37.31	54.00	-16.69	AVG	

Orthogonal Axis:	X
Test Mode:	UNII-3/TX A Mode 5745MHz

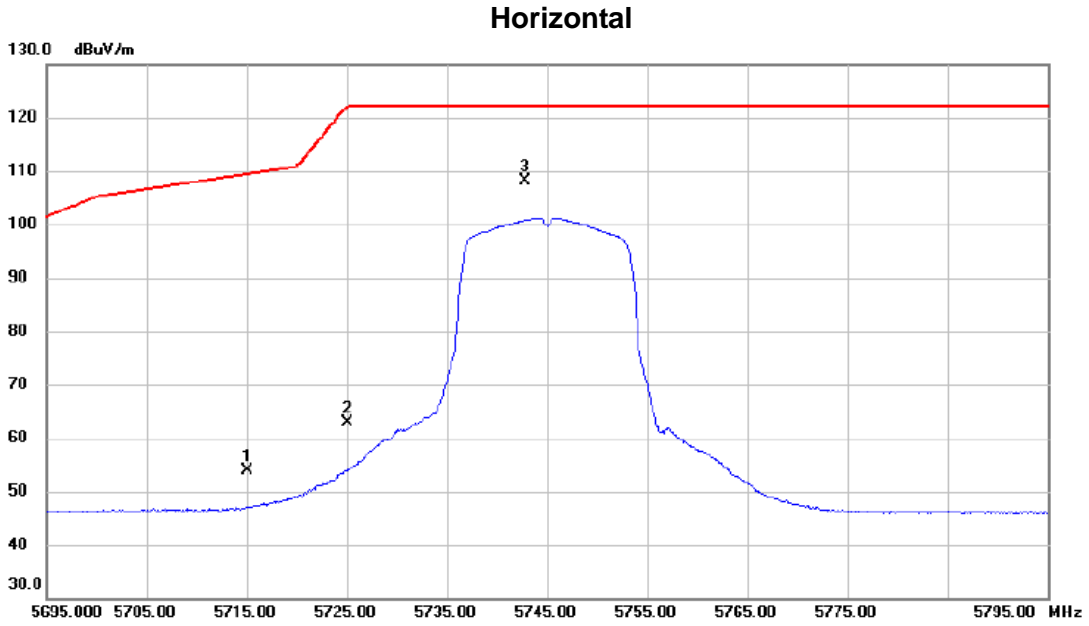

No.	Mk.	Freq.	Reading Level	Correct Factor	Measurement	Limit	Margin	Detector	Comment
		MHz	dBuV	dB	dBuV/m	dBuV/m	dB		
1		5715.000	35.57	18.40	53.97	109.40	-55.43	peak	
2		5725.000	44.48	18.43	62.91	122.20	-59.29	peak	
3	*	5742.800	89.64	18.50	108.14	122.20	-14.06	peak	

Orthogonal Axis:	X
Test Mode:	UNII-3/TX A Mode 5745MHz

Horizontal

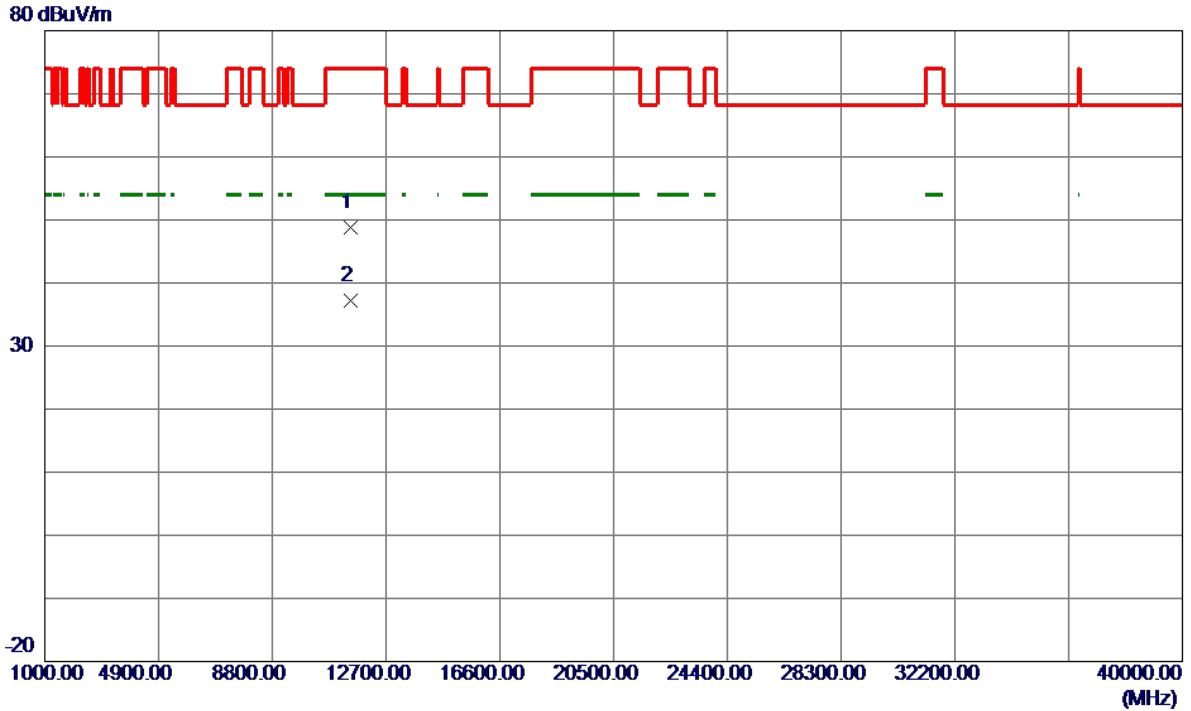

No.	Freq. MHz	Reading Level dBuV/m	Correct Factor dB	Measure ment dBuV/m	Limit dBuV/m	Margin dB	Detector	Comment
1	11487.7699	32.84	15.94	48.78	74.00	-25.22	Peak	
2 *	11492.4250	21.28	15.95	37.23	54.00	-16.77	AVG	

Orthogonal Axis:	X
Test Mode:	UNII-3/TX A Mode 5785MHz

Vertical

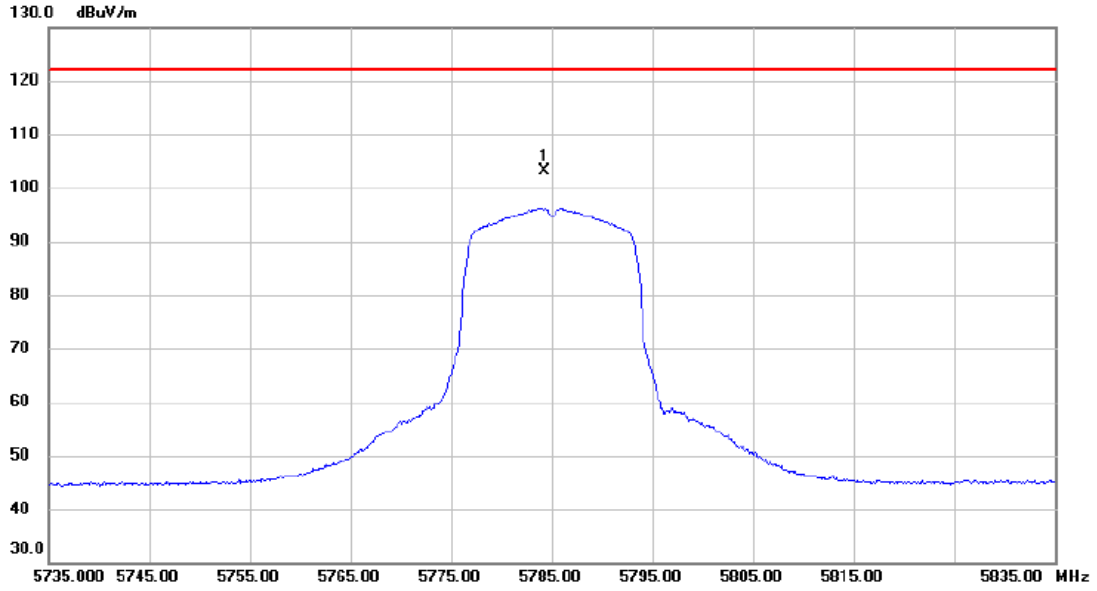

No.	Mk.	Freq.	Reading Level	Correct Factor	Measurement	Limit	Margin	Detector	Comment
		MHz	dBuV	dB	dBuV/m	dBuV/m	dB		
1	*	5784.300	84.45	18.65	103.10	122.20	-19.10	peak	

Orthogonal Axis:	X
Test Mode:	UNII-3/TX A Mode 5785MHz

Vertical

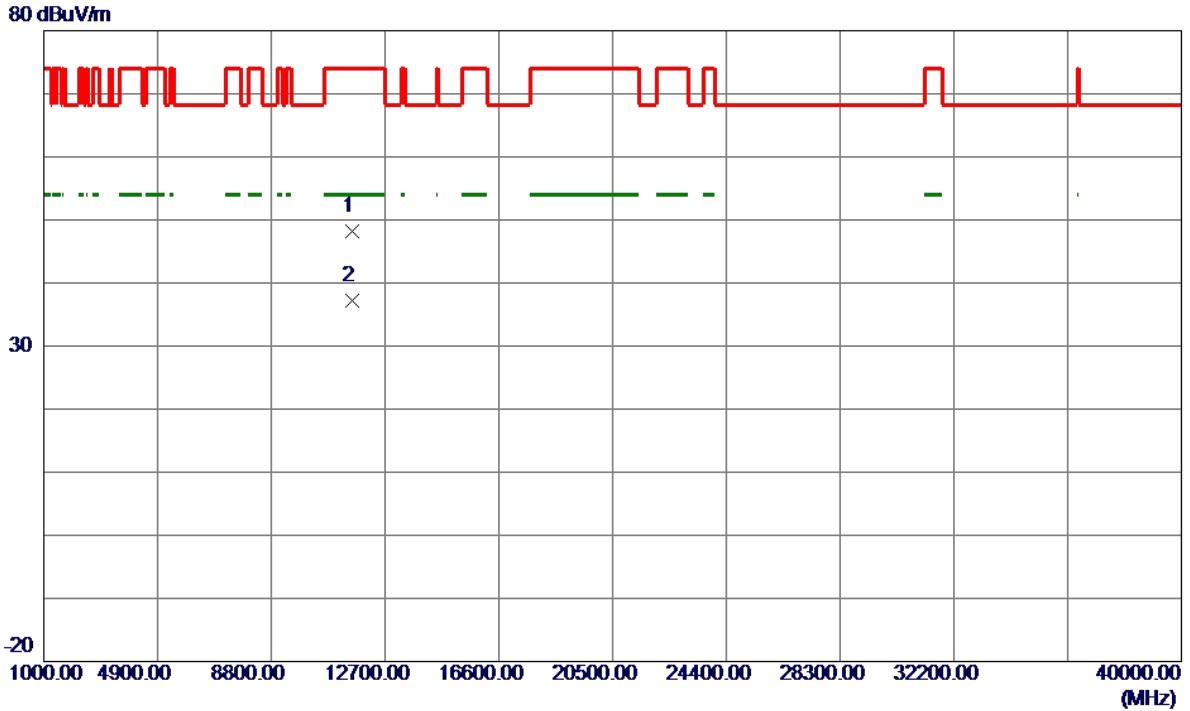

No.	Freq. MHz	Reading Level dBuV/m	Correct Factor dB	Measure ment dBuV/m	Limit dBuV/m	Margin dB	Detector	Comment
1	11567.8350	32.20	15.99	48.19	74.00	-25.81	Peak	
2 *	11569.2950	21.19	15.99	37.18	54.00	-16.82	AVG	

Orthogonal Axis:	X
Test Mode:	UNII-3/TX A Mode 5785MHz

Horizontal

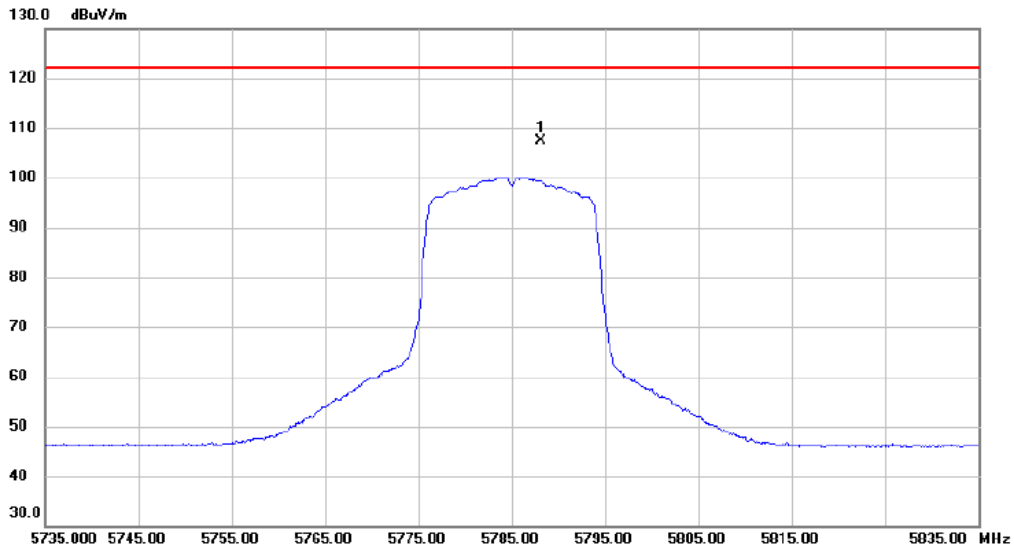

No.	Mk.	Freq. MHz	Reading Level dBuV	Correct Factor dB	Measure- ment dBuV/m	Limit dBuV/m	Margin dB	Detector	Comment
1	*	5788.200	88.67	18.66	107.33	122.20	-14.87	peak	

Orthogonal Axis:	X
Test Mode:	UNII-3/TX A Mode 5785MHz

Horizontal

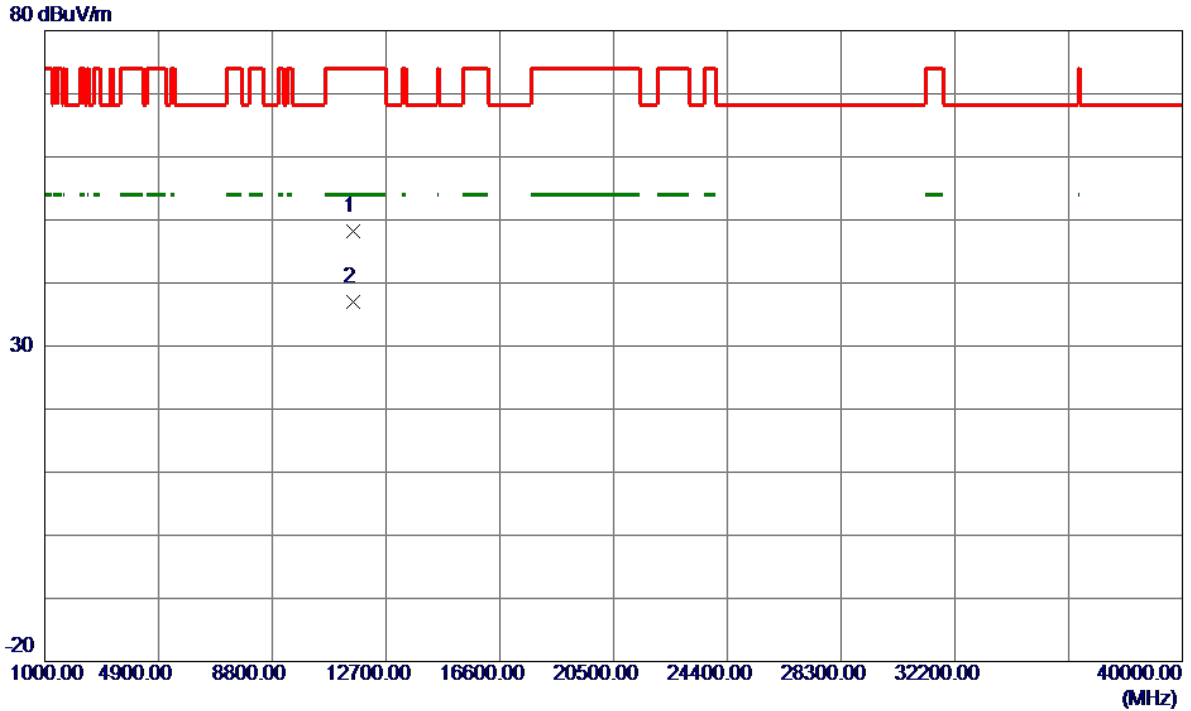

No.	Freq. MHz	Reading Level dBuV/m	Correct Factor dB	Measure ment dBuV/m	Limit dBuV/m	Margin dB	Detector	Comment
1	11567.9650	32.14	15.99	48.13	74.00	-25.87	Peak	
2 *	11572.1950	21.10	15.99	37.09	54.00	-16.91	AVG	