

# Test report

## 335282-2TRFWL

Date of issue: October 18, 2017

Applicant:

**Standard Innovation Corporation**

Product:

**Universal Board**

Model:

**7000**

FCC ID:

**ZUE7000**

IC Registration Number:

**9804A-7000**

Specifications:

◆ **FCC 47 CFR Part 15 Subpart C, §15.247**

Operation in the 902–928 MHz, 2400–2483.5 MHz, 5725–5850 MHz

◆ **RSS-247, Issue 2, February 2017, Section 5**

Digital Transmission Systems (DTSs), Frequency Hopping Systems (FHSs)  
and Licence-Exempt Local Area Network (LE-LAN) Devices

Test location

---

Company name	Nemko Canada Inc.
Address	303 River Road
City	Ottawa
Province	Ontario
Postal code	K1V 1H2
Country	Canada
Telephone	+1 613 737 9680
Facsimile	+1 613 737 9691
Toll free	+1 800 563 6336
Website	www.nemko.com
Site number	FCC: 176392; IC: 2040A-4 (3 m semi anechoic chamber)

Tested by	Predrag Golic, EMC Specialist
Reviewed by	Andrey Adelberg, Senior Wireless/EMC Specialist
Review date	October 18, 2017
Reviewer signature	

Limits of responsibility

---

Note that the results contained in this report relate only to the items tested and were obtained in the period between the date of initial receipt of samples and the date of issue of the report.

This test report has been completed in accordance with the requirements of ISO/IEC 17025. All results contain in this report are within Nemko Canada's ISO/IEC 17025 accreditation.

Copyright notification

---

Nemko Canada Inc. authorizes the applicant to reproduce this report provided it is reproduced in its entirety and for use by the company's employees only. Any use which a third party makes of this report, or any reliance on or decisions to be made based on it, are the responsibility of such third parties.

Nemko Canada Inc. accepts no responsibility for damages, if any, suffered by any third party as a result of decisions made or actions based on this report.

© Nemko Canada Inc.

## Table of contents

<b>Table of contents</b> .....	<b>3</b>
<b>Section 1. Report summary</b> .....	<b>4</b>
1.1 Applicant .....	4
1.2 Manufacturer .....	4
1.3 Test specifications .....	4
1.4 Test methods .....	4
1.5 Statement of compliance .....	4
1.6 Exclusions .....	4
1.7 Test report revision history .....	4
<b>Section 2. Summary of test results</b> .....	<b>5</b>
2.1 FCC Part 15 Subpart C, general requirements test results .....	5
2.2 FCC Part 15 Subpart C, intentional radiators test results .....	5
2.3 IC RSS-GEN, Issue 4, test results .....	5
2.4 IC RSS-247, Issue 2, test results .....	6
<b>Section 3. Equipment under test (EUT) details</b> .....	<b>7</b>
3.1 Sample information .....	7
3.2 EUT information .....	7
3.3 Technical information .....	7
3.4 Product description and theory of operation .....	7
3.5 EUT exercise details .....	7
3.6 EUT setup diagram .....	8
<b>Section 4. Engineering considerations</b> .....	<b>9</b>
4.1 Modifications incorporated in the EUT .....	9
4.2 Technical judgment .....	9
4.3 Deviations from laboratory tests procedures .....	9
<b>Section 5. Test conditions</b> .....	<b>10</b>
5.1 Atmospheric conditions .....	10
5.2 Power supply range .....	10
<b>Section 6. Measurement uncertainty</b> .....	<b>11</b>
6.1 Uncertainty of measurement .....	11
<b>Section 7. Test equipment</b> .....	<b>12</b>
7.1 Test equipment list .....	12
<b>Section 8. Testing data</b> .....	<b>13</b>
8.1 FCC 15.207(a) and RSS-Gen 8.8 AC power line conducted emissions limits .....	13
8.2 FCC 15.247(a)(2) and RSS-247 5.2(a) Minimum 6 dB bandwidth for systems using digital modulation techniques .....	16
8.3 FCC 15.247(b) and RSS-247 5.4 (d) Transmitter output power and e.i.r.p. requirements .....	18
8.4 FCC 15.247(e) and RSS-247 5.2(b) Power spectral density for digitally modulated devices .....	20
8.5 FCC 15.247(d) and RSS-247 5.5 Spurious (out-of-band) emissions .....	22
<b>Section 9. Block diagrams of test set-ups</b> .....	<b>27</b>
9.1 Radiated emissions set-up for frequencies below 1 GHz .....	27
9.2 Radiated emissions set-up for frequencies above 1 GHz .....	28
9.3 Conducted emissions set-up .....	28

## Section 1. Report summary

---

### 1.1 Applicant

---

Company name	Standard Innovation Corporation
Address	1130 Morrison Drive, Suite 330
City	Ottawa
Province/State	Ontario
Postal/Zip code	K2H 9N6
Country	Canada

### 1.2 Manufacturer

---

Company name	Seaco Technology Ltd.
Address	9/F, Guang Ying Building, No. 88 Di Hao Road
City	Zhang Mu Tao Town Dong Guan
Province/State	Guangdong Province
Country	China

### 1.3 Test specifications

---

FCC 47 CFR Part 15, Subpart C, Clause 15.247	Operation in the 902–928 MHz, 2400–2483.5 MHz, and 5725–585 MHz
RSS-247, Issue 2, February 2017, Section 5	Digital Transmission Systems (DTSs), Frequency Hopping Systems (FHSs) and Licence-Exempt Local Area Network (LE-LAN) Devices

### 1.4 Test methods

---

558074 D01 DTS Meas Guidance v04 (April 5, 2017)	Guidance for Performing Compliance Measurements on Digital Transmission Systems (DTS) Operating Under §15.247
ANSI C63.10 v2013	American National Standard of Procedures for Compliance Testing of Unlicensed Wireless Devices

### 1.5 Statement of compliance

---

In the configuration tested, the EUT was found compliant.

Testing was completed against all relevant requirements of the test standard. Results obtained indicate that the product under test complies in full with the requirements tested. The test results relate only to the items tested.

See “Summary of test results” for full details.

### 1.6 Exclusions

---

None

### 1.7 Test report revision history

---

Revision #	Details of changes made to test report
TRF	Original report issued

## Section 2. Summary of test results

### 2.1 FCC Part 15 Subpart C, general requirements test results

Part	Test description	Verdict
§15.207(a)	Conducted limits	Pass
§15.31(e)	Variation of power source	Pass <sup>1</sup>
§15.203	Antenna requirement	Pass <sup>2</sup>

Notes: <sup>1</sup> EUT was tested with the fully charged battery

<sup>2</sup> The Antennas are located within the enclosure of EUT and not user accessible.

### 2.2 FCC Part 15 Subpart C, intentional radiators test results

Part	Test description	Verdict
§15.247(a)(1)(i)	Frequency hopping systems operating in the 902–928 MHz band	Not applicable
§15.247(a)(1)(ii)	Frequency hopping systems operating in the 5725–5850 MHz band	Not applicable
§15.247(a)(1)(iii)	Frequency hopping systems operating in the 2400–2483.5 MHz band	Not applicable
§15.247(a)(2)	Minimum 6 dB bandwidth for systems using digital modulation techniques	Pass
§15.247(b)(1)	Maximum peak output power of frequency hopping systems operating in the 2400–2483.5 MHz band and 5725–5850 MHz band	Not applicable
§15.247(b)(2)	Maximum peak output power of Frequency hopping systems operating in the 902–928 MHz band	Not applicable
§15.247(b)(3)	Maximum peak output power of systems using digital modulation in the 902–928 MHz, 2400–2483.5 MHz, and 5725–5850 MHz bands	Pass
§15.247(c)(1)	Fixed point-to-point operation with directional antenna gains greater than 6 dBi	Not applicable
§15.247(c)(2)	Transmitters operating in the 2400–2483.5 MHz band that emit multiple directional beams	Not applicable
§15.247(d)	Spurious emissions	Pass
§15.247(e)	Power spectral density for digitally modulated devices	Pass
§15.247(f)	Time of occupancy for hybrid systems	Not applicable

### 2.3 IC RSS-GEN, Issue 4, test results

Part	Test description	Verdict
7.1.2	Receiver radiated emission limits	Not applicable
7.1.3	Receiver conducted emission limits	Not applicable
8.8	Power Line Conducted Emissions Limits for Licence-Exempt Radio Apparatus	Pass

Notes: <sup>1</sup> According to sections 5.2 and 5.3 of RSS-Gen, Issue 4 the EUT does not have a stand-alone receiver neither scanner receiver, therefore exempt from receiver requirements.

## 2.4 IC RSS-247, Issue 2, test results

Part	Test description	Verdict
5.1	Frequency Hopping Systems (FHSs)	
5.1 (1)	Bandwidth of a frequency hopping channel	Not applicable
5.1 (2)	Minimum channel spacing for frequency hopping systems	Not applicable
5.1 (3)	Frequency hopping systems operating in the 902–928 MHz band	Not applicable
5.1 (4)	Frequency hopping systems operating in the 2400–2483.5 MHz band	Not applicable
5.1 (5)	Frequency hopping systems operating in the 5725–5850 MHz band	Not applicable
5.2	Digital Transmission Systems (DTSS)	
5.2 (1)	Minimum 6 dB bandwidth	Pass
5.2 (2)	Maximum power spectral density	Pass
5.3	Hybrid Systems	
5.3 (1)	Digital modulation turned off	Not applicable
5.3 (2)	Frequency hopping turned off	Not applicable
5.4	Transmitter output power and e.i.r.p. requirements	
5.4 (1)	Frequency hopping systems operating in the 902–928 MHz band	Not applicable
5.4 (2)	Frequency hopping systems operating in the 2400–2483.5 MHz band	Not applicable
5.4 (3)	Frequency hopping systems operating in the 5725–5850 MHz	Not applicable
5.4 (4)	Systems employing digital modulation techniques	Pass
5.4 (5)	Point-to-point systems in 2400–2483.5 MHz and 5725–5850 MHz band	Not applicable
5.4 (6)	Transmitters which operate in the 2400–2483.5 MHz band with multiple directional beams	Not applicable
5.5	Out-of-band emissions	Pass

Notes: None

## Section 3. Equipment under test (EUT) details

---

### 3.1 Sample information

---

Receipt date	September 8, 2017
Nemko sample ID number	# 2

### 3.2 EUT information

---

Product name	Universal board
Model	7000
Serial number	Preproduction

### 3.3 Technical information

---

Applicant IC company number	9804A
IC UPN number	7000
All used IC test site(s) Reg. number	2040A-4
RSS number and Issue number	RSS-247 Issue 2, February 2017
Frequency band	2400–2483.5 MHz
Frequency Min (MHz)	2402
Frequency Max (MHz)	2480
RF power Min (W)	N/A
RF power Max (W), Conducted	0.00001205 (–19.19 dBm)
Field strength, Units @ distance	N/A
Measured BW (kHz) (6 dB)	681.09
Calculated BW (kHz), as per TRC-43	N/A
Type of modulation	GFSK
Emission classification (F1D, G1D, D1D)	F1D
Transmitter spurious, Units @ distance	48.61 dB $\mu$ V/m at 12650 MHz @ 3 m
Power requirements	Internal rechargeable 3.7 V lithium ion battery via USB charger.
Antenna information	Monopole whip antenna, using 30-gauge wire with 0 dBi gain The EUT uses a unique antenna coupling/ non-detachable antenna to the intentional radiator.

### 3.4 Product description and theory of operation

---

This product includes a 3.7 V lithium ion battery, motor control drivers, charging and battery protection circuits, and a 2.4 GHz Bluetooth LE SoC (system on chip) with antenna matching network. The SoC operates at 32 MHz with a 32 MHz crystal. The radio communication is in accordance with Bluetooth LE PHY specification 4.0.

### 3.5 EUT exercise details

---

EUT was controlled wirelessly from Android tablet.

### 3.6 EUT setup diagram

---

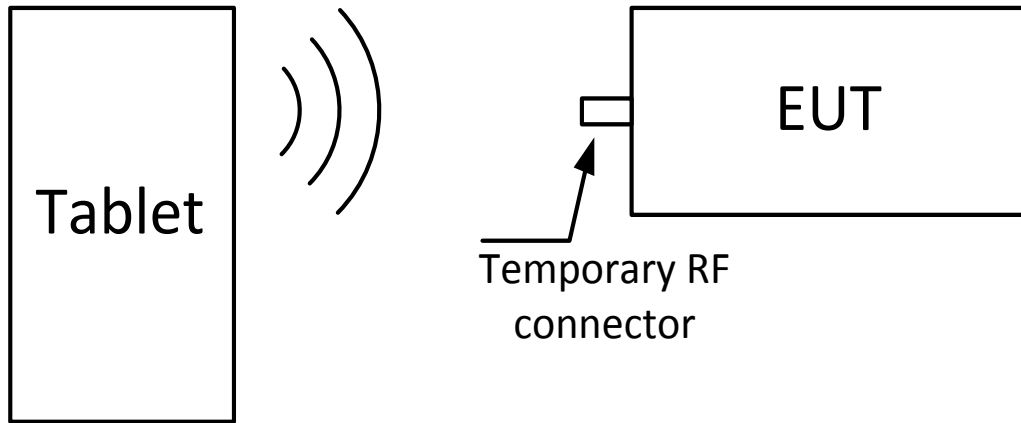

Figure 3.6-1: Setup diagram



## Section 4. Engineering considerations

---

---

### 4.1 Modifications incorporated in the EUT

---

There were no modifications performed to the EUT during this assessment.

### 4.2 Technical judgment

---

None

### 4.3 Deviations from laboratory tests procedures

---

No deviations were made from laboratory procedures.

## Section 5. Test conditions

---

---

### 5.1 Atmospheric conditions

---

Temperature	15–30 °C
Relative humidity	20–75 %
Air pressure	860–1060 mbar

---

When it is impracticable to carry out tests under these conditions, a note to this effect stating the ambient temperature and relative humidity during the tests shall be recorded and stated.

### 5.2 Power supply range

---

---

The normal test voltage for equipment to be connected to the mains shall be the nominal mains voltage. For the purpose of the present document, the nominal voltage shall be the declared voltage, or any of the declared voltages  $\pm 5\%$ , for which the equipment was designed.

## Section 6. Measurement uncertainty

---

### 6.1 Uncertainty of measurement

---

Measurement uncertainty budgets for the tests are detailed below. Measurement uncertainty calculations assume a coverage factor of  $K = 2$  with 95% certainty.

Test name	Measurement uncertainty, dB
All antenna port measurements	0.55
Conducted spurious emissions	1.13
Radiated spurious emissions	3.78
AC power line conducted emissions	3.55

## Section 7. Test equipment

### 7.1 Test equipment list

*Table 7.1-1: Equipment list*

Equipment	Manufacturer	Model no.	Asset no.	Cal cycle	Next cal.
3 m EMI test chamber	TDK	SAC-3	FA002047	1 year	Dec. 1/17
Flush mount turntable	Sunol	FM2022	FA002082	—	NCR
Controller	Sunol	SC104V	FA002060	—	NCR
Antenna mast	Sunol	TLT2	FA002061	—	NCR
AC Power source	Chenwa	2700M-10k	FA002716	—	VOU
Receiver/spectrum analyzer	Rohde & Schwarz	ESU 26	FA002043	1 year	Jan. 31/18
Spectrum analyzer	Rohde & Schwarz	FSU	FA001877	1 year	Jul. 18/18
Bilog antenna (20–3000 MHz)	Sunol	JB3	FA002108	1 year	June 27/18
Horn with Preamp	ETS-Lindgren	3117-PA	FA002840	1 year	Nov. 11/17
Horn antenna (18–40 GHz)	EMCO	3116	FA001847	1 year	June 27/18
Pre-amplifier (18–26 GHz)	Narda	BBS-1826N612	FA001550	—	VOU
LISN	Rohde & Schwarz	ENV216	FA002023	1 year	May 19/18

Note: NCR - no calibration required, VOU - verify on use

## Section 8. Testing data

### 8.1 FCC 15.207(a) and RSS-Gen 8.8 AC power line conducted emissions limits

#### 8.1.1 Definitions and limits

**FCC:**

Except as shown in paragraphs (b) and (c) of this section, for an intentional radiator that is designed to be connected to the public utility (AC) power line, the radio frequency voltage that is conducted back onto the AC power line on any frequency or frequencies, within the band 150 kHz to 30 MHz, shall not exceed the limits in the following table, as measured using a 50  $\mu$ H/50  $\Omega$  line impedance stabilization network (LISN). Compliance with the provisions of this paragraph shall be based on the measurement of the radio frequency voltage between each power line and ground at the power terminal. The lower limit applies at the boundary between the frequency ranges.

**ISED:**

A radio apparatus that is designed to be connected to the public utility (AC) power line shall ensure that the radio frequency voltage, which is conducted back onto the AC power line on any frequency or frequencies within the band 150 kHz to 30 MHz, shall not exceed the limits in table below.

Unless the requirements applicable to a given device state otherwise, for any radio apparatus equipped to operate from the public utility AC power supply either directly or indirectly (such as with a battery charger), the radio frequency voltage of emissions conducted back onto the AC power lines in the frequency range of 0.15 MHz to 30 MHz shall not exceed the limits shown in table below. The more stringent limit applies at the frequency range boundaries.

**Table 8.1-1: Conducted emissions limit**

Frequency of emission, MHz	Conducted limit, dB $\mu$ V	
	Quasi-peak	Average**
0.15–0.5	66 to 56*	56 to 46*
0.5–5	56	46
5–30	60	50

Note: \* - The level decreases linearly with the logarithm of the frequency.

\*\* - A linear average detector is required.

#### 8.1.2 Test summary

Test date	September 11, 2017	Temperature	23 °C
Test engineer	Predrag Golic	Air pressure	1020 mbar
Verdict	Pass	Relative humidity	60 %

### 8.1.3 Observations, settings and special notes

---

The EUT was set up as tabletop configuration.

The spectral scan has been corrected with transducer factors (i.e. cable loss, LISN factors, and attenuators) for determination of compliance.

A preview measurement was generated with the receiver in continuous scan mode. Emissions detected within 6 dB or above limit were re-measured with the appropriate detector against the correlating limit and recorded as the final measurement.

Receiver settings for preview measurements:

Resolution bandwidth	9 kHz
Video bandwidth	30 kHz
Detector mode	Peak and Average
Trace mode	Max Hold
Measurement time	100 ms

Receiver settings for final measurements:

Resolution bandwidth	9 kHz
Video bandwidth	30 kHz
Detector mode	Quasi-Peak and Average
Trace mode	Max Hold
Measurement time	160 ms

8.1.4 Test data

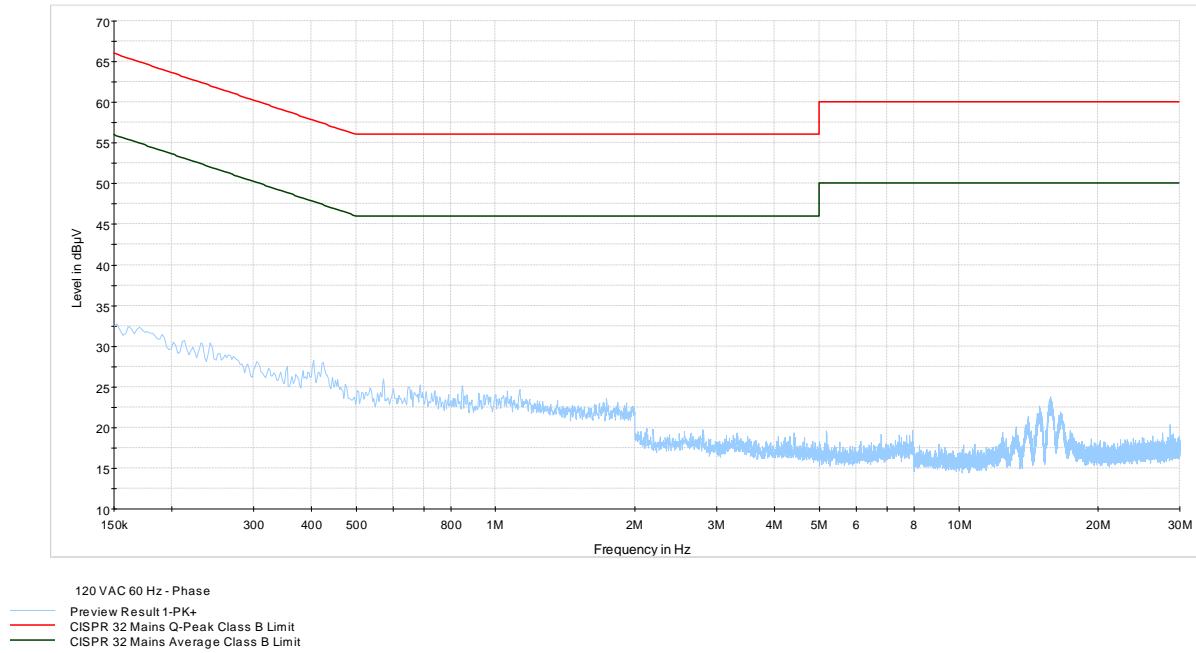

Plot 8.1-1: Conducted emissions on phase line

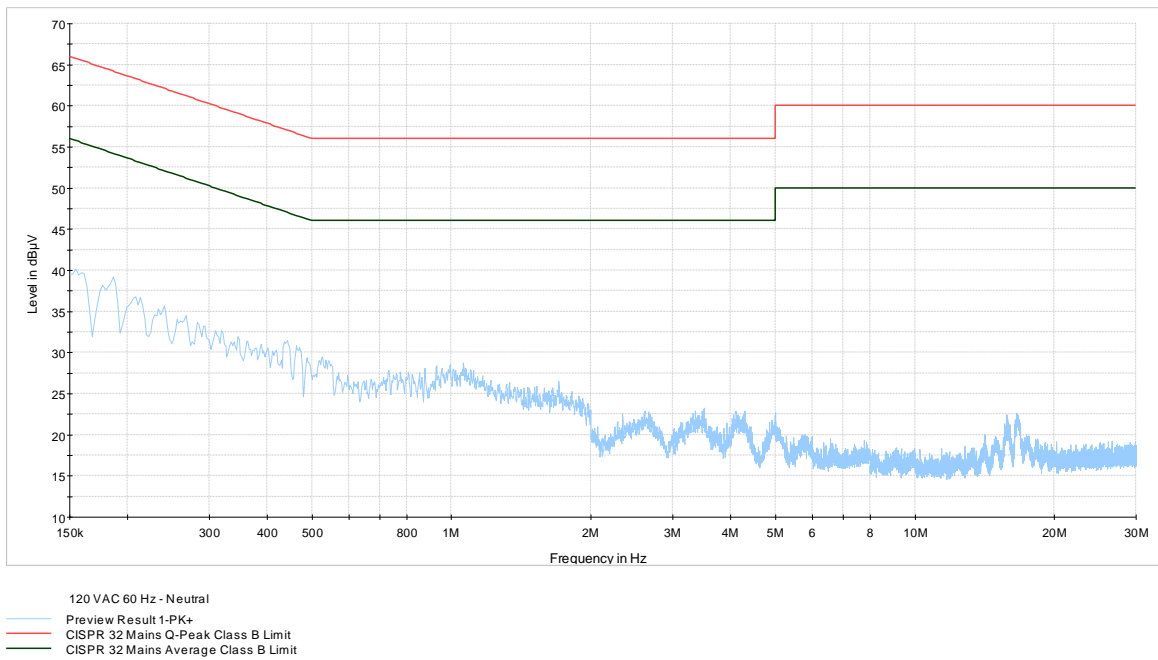

Plot 8.1-2: Conducted emissions on neutral line

## 8.2 FCC 15.247(a)(2) and RSS-247 5.2(a) Minimum 6 dB bandwidth for systems using digital modulation techniques

---

### 8.2.1 Definitions and limits

---

**FCC and ISED:**

- (a) Operation under the provisions of this Section is limited to frequency hopping and digitally modulated intentional radiators that comply with the following provisions:
- (2) Systems using digital modulation techniques may operate in the 902–928 MHz, 2400–2483.5 MHz and 5725–5850 MHz bands. The minimum 6 dB bandwidth shall be at least 500 kHz.

### 8.2.2 Test summary

---

Test date	September 18, 2017	Temperature	23 °C
Test engineer	Predrag Golic	Air pressure	1010 mbar
Verdict	Pass	Relative humidity	57 %

### 8.2.3 Observations, settings and special notes

---

Spectrum analyser settings:

Resolution bandwidth	100 kHz
Video bandwidth	$\geq 3 \times \text{RBW}$
Frequency span	5 MHz
Detector mode	Peak
Trace mode	Max Hold

### 8.2.4 Test data

---

**Table 8.2-1: 6 dB bandwidth results**

Frequency, MHz	6 dB bandwidth, MHz	Limit, MHz	Margin, MHz
2402	0.681	0.500	0.181
2440	0.689	0.500	0.189
2480	0.697	0.500	0.197



Section 8

Test name

Specification

Testing data

FCC 15.247(a)(2) and RSS-247 5.2(a) Minimum 6 dB bandwidth for systems using digital modulation techniques

FCC Part 15 Subpart C and RSS-247, Issue 2

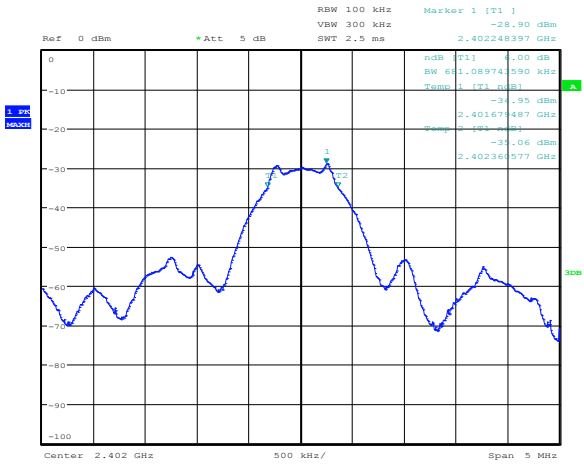

Date: 18.SEP.2017 08:36:52

Figure 8.2-1: 6 dB bandwidth on low channel

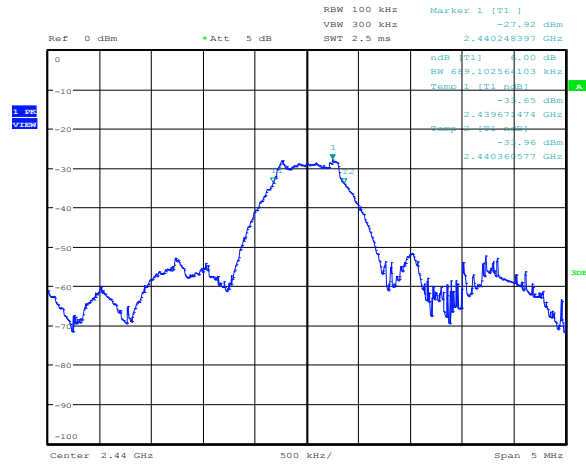

Date: 18.SEP.2017 08:38:59

Figure 8.2-2: 6 dB bandwidth on mid channel

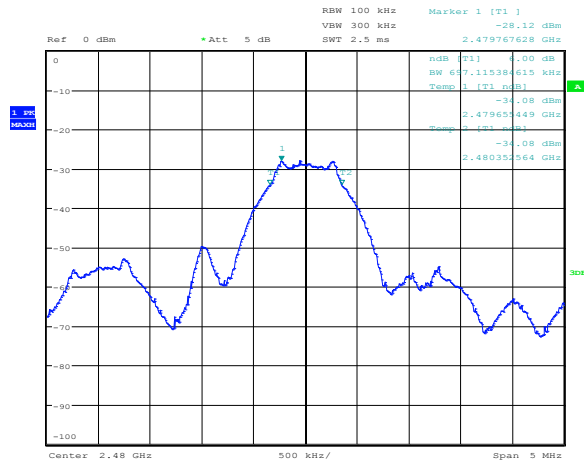

Date: 18.SEP.2017 08:40:01

Figure 8.2-3: 6 dB bandwidth on high channel

## 8.3 FCC 15.247(b) and RSS-247 5.4 (d) Transmitter output power and e.i.r.p. requirements

### 8.3.1 Definitions and limits

**FCC:**

- (b) The maximum peak conducted output power of the intentional radiator shall not exceed the following:
- (3) For systems using digital modulation in the 902–928 MHz, 2400–2483.5 MHz, and 5725–5850 MHz bands: 1 W (30 dBm). As an alternative to a peak power measurement, compliance with the one Watt limit can be based on a measurement of the maximum conducted output power. Maximum Conducted Output Power is defined as the total transmit power delivered to all antennas and antenna elements averaged across all symbols in the signaling alphabet when the transmitter is operating at its maximum power control level. Power must be summed across all antennas and antenna elements. The average must not include any time intervals during which the transmitter is off or is transmitting at a reduced power level. If multiple modes of operation are possible (e.g., alternative modulation methods), the maximum conducted output power is the highest total transmit power occurring in any mode.
  - (4) The conducted output power limit specified in paragraph (b) of this section is based on the use of antennas with directional gains that do not exceed 6 dBi. Except as shown in paragraph (c) of this section, if transmitting antennas of directional gain greater than 6 dBi are used, the conducted output power from the intentional radiator shall be reduced below the stated values in paragraphs (b)(1), (b)(2), and (b)(3) of this section, as appropriate, by the amount in dB that the directional gain of the antenna exceeds 6 dBi.
    - (i) Systems operating in the 2400–2483.5 MHz band that are used exclusively for fixed, point-to-point operations may employ transmitting antennas with directional gain greater than 6 dBi provided the maximum peak output power of the intentional radiator is reduced by 1 dB for every 3 dB that the directional gain of the antenna exceeds 6 dBi.

Fixed, point-to-point operation, as used in paragraphs (b)(3)(i) and (b)(3)(ii) of this section, excludes the use of point-to-multipoint systems, omnidirectional applications, and multiple co-located intentional radiators transmitting the same information. The operator of the spread spectrum intentional radiator or, if the equipment is professionally installed, the installer is responsible for ensuring that the system is used exclusively for fixed, point-to-point operations. The instruction manual furnished with the intentional radiator shall contain language in the installation instructions informing the operator and the installer of this responsibility.

- (c) Operation with directional antenna gains greater than 6 dBi.
- (2) In addition to the provisions in paragraphs (b)(1), (b)(3), (b)(4) and (c)(1)(i) of this section, transmitters operating in the 2400–2483.5 MHz band that emit multiple directional beams, simultaneously or sequentially, for the purpose of directing signals to individual receivers or to groups of receivers provided the emissions comply with the following:
    - (i) Different information must be transmitted to each receiver.
    - (ii) If the transmitter employs an antenna system that emits multiple directional beams but does not do emit multiple directional beams simultaneously, the total output power conducted to the array or arrays that comprise the device, i.e., the sum of the power supplied to all antennas, antenna elements, staves, etc. and summed across all carriers or frequency channels, shall not exceed the limit specified in paragraph (b)(1) or (b)(3) of this section, as applicable. However, the total conducted output power shall be reduced by 1 dB below the specified limits for each 3 dB that the directional gain of the antenna/antenna array exceeds 6 dBi. The directional antenna gain shall be computed as follows:
      - (A) The directional gain shall be calculated as the sum of 10 log (number of array elements or staves) plus the directional gain of the element or stave having the highest gain.

**ISED:**

For DTSs employing digital modulation techniques operating in the bands 902–928 MHz and 2400–2483.5 MHz, the maximum peak conducted output power shall not exceed 1 W. The e.i.r.p. shall not exceed 4 W, except as provided in section 5.4(e).

5.4(e) Fixed point-to-point systems in the bands 2400–2483.5 MHz and 5725–5850 MHz are permitted to have an e.i.r.p. higher than 4 W provided that the higher e.i.r.p. is achieved by employing higher gain directional antennas and not higher transmitter output powers. Point-to-multipoint systems, omnidirectional applications and multiple co-located transmitters transmitting the same information are prohibited from exceeding an e.i.r.p. of 4 W.

### 8.3.2 Test summary

Test date	September 14, 2017	Temperature	21 °C
Test engineer	Predrag Golic	Air pressure	1015 mbar
Verdict	Pass	Relative humidity	45 %

### 8.3.3 Observations, settings and special notes

Spectrum analyser settings for output power:

Resolution bandwidth	1 MHz
Video bandwidth	≥3 × RBW
Frequency span	10 MHz
Detector mode	Peak
Trace mode	Max Hold

### 8.3.4 Test data

**Table 8.3-1: Output power and EIRP results**

Frequency, MHz	Output power, dBm	Output power limit, dBm	Margin, dB	Antenna gain, dBi	EIRP, dBm	EIRP limit, dBm	EIRP margin, dB
2402	-19.19	30.00	50.59	0.00	-19.19	36.00	56.59
2440	-20.90	30.00	52.63	0.00	-20.90	36.00	58.63
2480	-22.54	30.00	55.16	0.00	-22.54	36.00	61.16

EIRP = Output power + Antenna gain

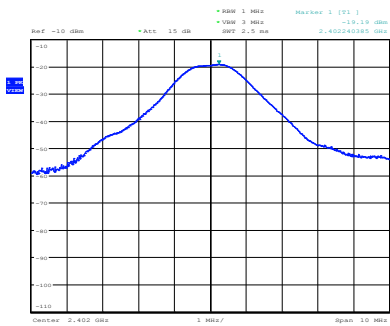

Date: 13.SEP.2017 14:21:55

**Figure 8.3-1: Output power on low channel**

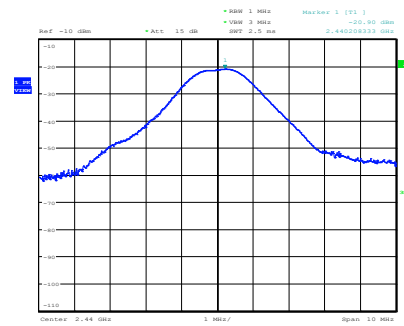

Date: 13.SEP.2017 14:20:51

**Figure 8.3-2: Output power on mid channel**

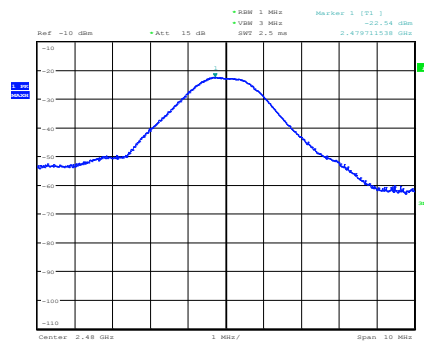

Date: 13.SEP.2017 14:18:55

**Figure 8.3-3: Output power on high channel**

## 8.4 FCC 15.247(e) and RSS-247 5.2(b) Power spectral density for digitally modulated devices

### 8.4.1 Definitions and limits

**FCC:**

For digitally modulated systems, the power spectral density conducted from the intentional radiator to the antenna shall not be greater than 8 dBm in any 3 kHz band during any time interval of continuous transmission. This power spectral density shall be determined in accordance with the provisions of paragraph (b) of this section. The same method of determining the conducted output power shall be used to determine the power spectral density.

**ISED:**

The transmitter power spectral density conducted from the transmitter to the antenna shall not be greater than 8 dBm in any 3 kHz band during any time interval of continuous transmission. This power spectral density shall be determined in accordance with the provisions of Section 5.4(d), (i.e. the power spectral density shall be determined using the same method as is used to determine the conducted output power).

### 8.4.2 Test summary

Test date	September 18, 2017	Temperature	23 °C
Test engineer	Predrag Golic	Air pressure	1010 mbar
Verdict	Pass	Relative humidity	56 %

### 8.4.3 Observations, settings and special notes

The test was performed using peak method. Spectrum analyser settings:

Resolution bandwidth:	3 kHz
Video bandwidth:	10 kHz
Frequency span:	5 MHz
Detector mode:	Peak
Trace mode:	Max-hold

### 8.4.4 Test data

**Table 8.4-1:** PSD measurements results

Frequency, MHz	PSD, dBm/3 kHz	PSD limit, dBm/3 kHz	Margin, dB
2402	-41.31	8.00	49.31
2440	-40.08	8.00	48.08
2480	-40.37	8.00	48.37

8.4.4 Test data, continued

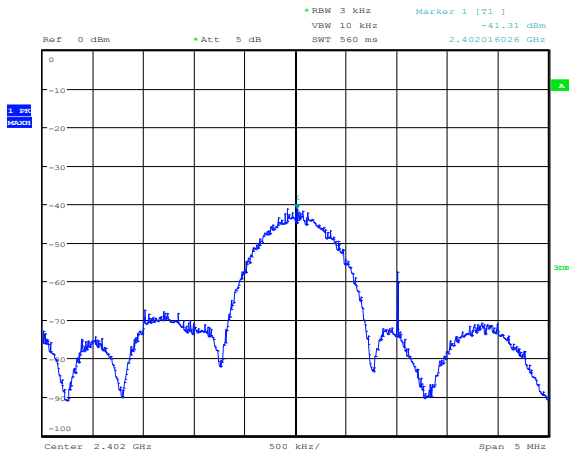

Date: 18.SEP.2017 08:46:54

Figure 8.4-1: PSD sample plot on low channel

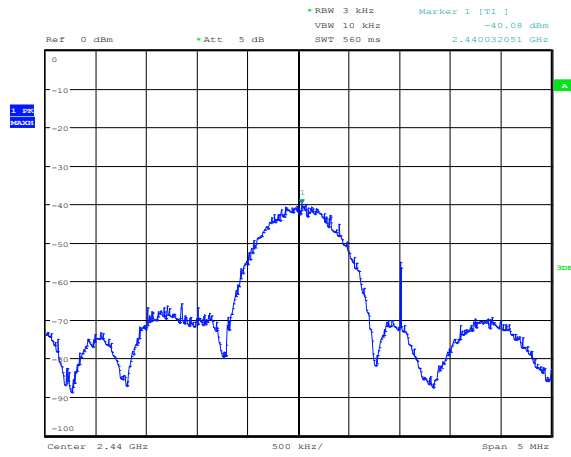

Date: 18.SEP.2017 08:45:04

Figure 8.4-2: PSD sample plot on mid channel

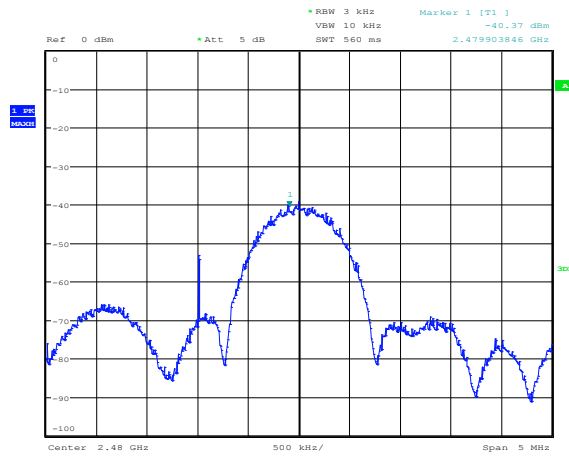

Date: 18.SEP.2017 08:43:33

Figure 8.4-3: PSD sample plot on high channel

## 8.5 FCC 15.247(d) and RSS-247 5.5 Spurious (out-of-band) emissions

### 8.5.1 Definitions and limits

#### FCC:

In any 100 kHz bandwidth outside the frequency band in which the spread spectrum or digitally modulated intentional radiator is operating, the radio frequency power that is produced by the intentional radiator shall be at least 20 dB below that in the 100 kHz bandwidth within the band that contains the highest level of the desired power, based on either an RF conducted or a radiated measurement, provided the transmitter demonstrates compliance with the peak conducted power limits. Attenuation below the general limits specified in §15.209(a) is not required. In addition, radiated emissions which fall in the restricted bands, as defined in §15.205(a), must also comply with the radiated emission limits specified in §15.209(a) (see §15.205(c)).

#### ISED:

In any 100 kHz bandwidth outside the frequency band in which the spread spectrum or digitally modulated device is operating, the RF power that is produced shall be at least 20 dB below that in the 100 kHz bandwidth within the band that contains the highest level of the desired power, based on either an RF conducted or a radiated measurement, provided that the transmitter demonstrates compliance with the peak conducted power limits. If the transmitter complies with the conducted power limits based on the use of root-mean-square averaging over a time interval, as permitted under Section 5.4(d), the attenuation required shall be 30 dB instead of 20 dB. Attenuation below the general field strength limits specified in RSS-Gen is not required.

**Table 8.5-1: FCC §15.209 and RSS-Gen – Radiated emission limits**

Frequency, MHz	Field strength of emissions		Measurement distance, m
	µV/m	dBµV/m	
0.009–0.490	2400/F	$67.6 - 20 \times \log_{10}(F)$	300
0.490–1.705	24000/F	$87.6 - 20 \times \log_{10}(F)$	30
1.705–30.0	30	29.5	30
30–88	100	40.0	3
88–216	150	43.5	3
216–960	200	46.0	3
above 960	500	54.0	3

Notes: In the emission table above, the tighter limit applies at the band edges.

For frequencies above 1 GHz the limit on peak RF emissions is 20 dB above the maximum permitted average emission limit applicable to the equipment under test

**Table 8.5-2: ISED restricted frequency bands**

MHz	MHz	MHz	GHz
0.090–0.110	12.51975–12.52025	399.9–410	5.35–5.46
2.1735–2.1905	12.57675–12.57725	608–614	7.25–7.75
3.020–3.026	13.36–13.41	960–1427	8.025–8.5
4.125–4.128	16.42–16.423	1435–1626.5	9.0–9.2
4.17725–4.17775	16.69475–16.69525	1645.5–1646.5	9.3–9.5
4.20725–4.20775	16.80425–16.80475	1660–1710	10.6–12.7
5.677–5.683	25.5–25.67	1718.8–1722.2	13.25–13.4
6.215–6.218	37.5–38.25	2200–2300	14.47–14.5
6.26775–6.26825	73–74.6	2310–2390	15.35–16.2
6.31175–6.31225	74.8–75.2	2655–2900	17.7–21.4
8.291–8.294	108–138	3260–3267	22.01–23.12
8.362–8.366	156.52475–156.52525	3332–3339	23.6–24.0
8.37625–8.38675	156.7–156.9	3345.8–3358	31.2–31.8
8.41425–8.41475	240–285	3500–4400	36.43–36.5
12.29–12.293	322–335.4	4500–5150	Above 38.6

Note: Certain frequency bands listed in Table 8.5-2 and above 38.6 GHz are designated for low-power licence-exempt applications. These frequency bands and the requirements that apply to the devices are set out in this Standard

**Table 8.5-3: FCC restricted frequency bands**

MHz	MHz	MHz	GHz
0.090–0.110	16.42–16.423	399.9–410	4.5–5.15
0.495–0.505	16.69475–16.69525	608–614	5.35–5.46
2.1735–2.1905	16.80425–16.80475	960–1240	7.25–7.75
4.125–4.128	25.5–25.67	1300–1427	8.025–8.5
4.17725–4.17775	37.5–38.25	1435–1626.5	9.0–9.2
4.20725–4.20775	73–74.6	1645.5–1646.5	9.3–9.5
6.215–6.218	74.8–75.2	1660–1710	10.6–12.7
6.26775–6.26825	108–121.94	1718.8–1722.2	13.25–13.4
6.31175–6.31225	123–138	2200–2300	14.47–14.5
8.291–8.294	149.9–150.05	2310–2390	15.35–16.2
8.362–8.366	156.52475–156.52525	2483.5–2500	17.7–21.4
8.37625–8.38675	156.7–156.9	2690–2900	22.01–23.12
8.41425–8.41475	162.0125–167.17	3260–3267	23.6–24.0
12.29–12.293	167.72–173.2	3332–3339	31.2–31.8
12.51975–12.52025	240–285	3345.8–3358	36.43–36.5
12.57675–12.57725	322–335.4	3600–4400	Above 38.6
13.36–13.41			

### 8.5.2 Test summary

Test date	September 18, 2017	Temperature	23 °C
Test engineer	Predrag Golic	Air pressure	1010 mbar
Verdict	Pass	Relative humidity	55 %

### 8.5.3 Observations, settings and special notes

The spectrum was searched from 30 MHz to the 10<sup>th</sup> harmonic.  
 EUT was set to transmit with 100 % duty cycle.  
 Radiated measurements were performed at a distance of 3 m.  
 Since fundamental power was tested using peak method, the spurious emissions limit is –20 dBc/100 kHz

Spectrum analyser settings for radiated measurements within restricted bands below 1 GHz:

Resolution bandwidth:	100 kHz
Video bandwidth:	300 kHz
Detector mode:	Peak
Trace mode:	Max Hold

Spectrum analyser settings for peak radiated measurements within restricted bands above 1 GHz:

Resolution bandwidth:	1 MHz
Video bandwidth:	3 MHz
Detector mode:	Peak
Trace mode:	Max Hold

Spectrum analyser settings for average radiated measurements within restricted bands above 1 GHz:

Resolution bandwidth:	1 MHz
Video bandwidth:	10 Hz
Detector mode:	Peak
Trace mode:	Max Hold

Spectrum analyser settings for conducted spurious emissions measurements:

Resolution bandwidth:	100 kHz
Video bandwidth:	300 kHz
Detector mode:	Peak
Trace mode:	Max Hold

### 8.5.4 Test data

**Table 8.5-4: Radiated field strength measurement results**

Channel	Frequency, MHz	Peak field strength, dB $\mu$ V/m	Average limit, dB $\mu$ V/m	Margin, dB
Low	3333	44.06	54.00	9.94
Low	6115	46.33	54.00	7.67
Mid	4904	45.01	54.00	8.99
Mid	6001	46.22	54.00	7.78
High	4963	46.65	54.00	7.35
High	12650	48.61	54.00	5.39

Notes: Field strength includes correction factor of antenna, cable loss, amplifier, and attenuators where applicable. All peak emissions comply with average limits, therefore no average measurements were performed.

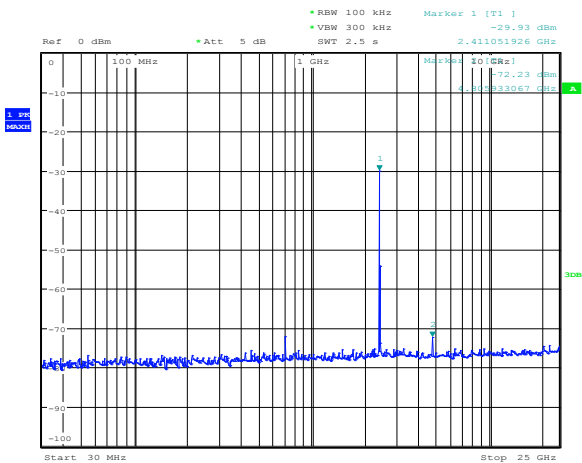

Date: 18.SEP.2017 08:59:41

**Figure 8.5-1: Conducted spurious emissions outside restricted bands, low channel**

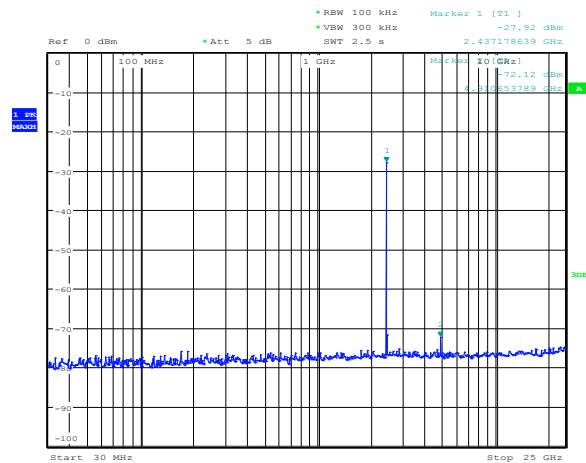

Date: 18.SEP.2017 08:57:40

**Figure 8.5-2: Conducted spurious emissions outside restricted bands, mid channel**



8.5.4 Test data, continued

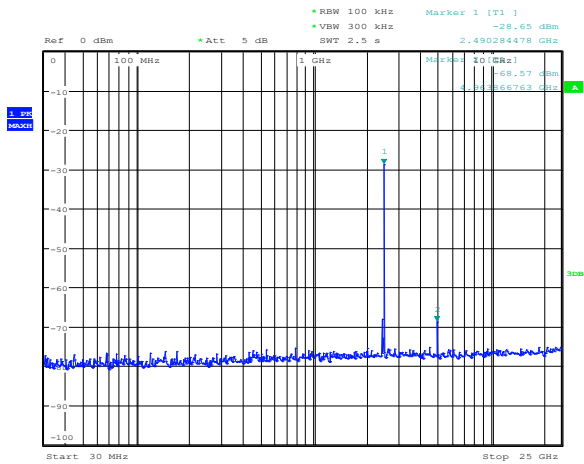

Date: 18.SEP.2017 09:01:25

Figure 8.5-3: Conducted spurious emissions outside restricted bands, high channel

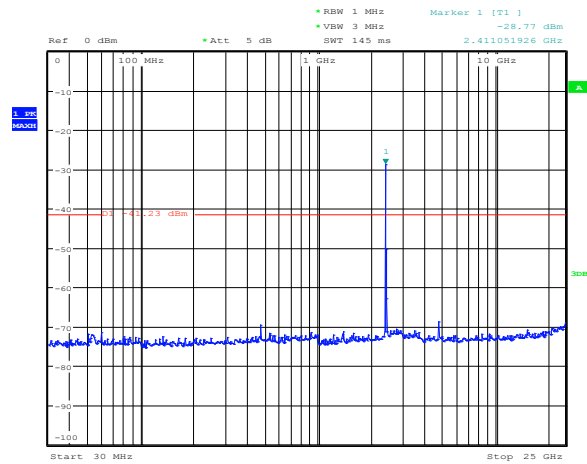

Date: 18.SEP.2017 09:08:22

Figure 8.5-4: Conducted spurious emissions within restricted bands, low channel

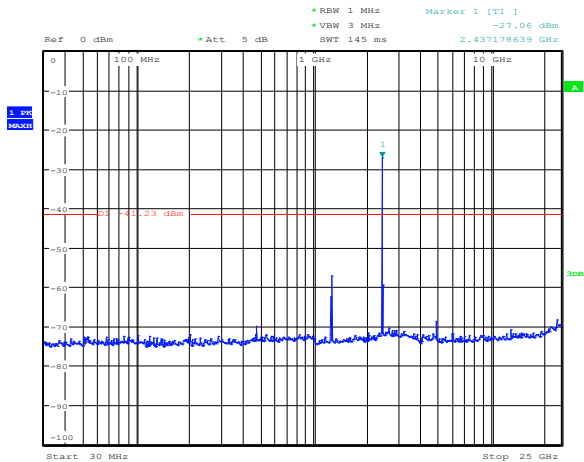

Date: 18.SEP.2017 09:07:20

Figure 8.5-5: Conducted spurious emissions outside restricted bands, mid channel

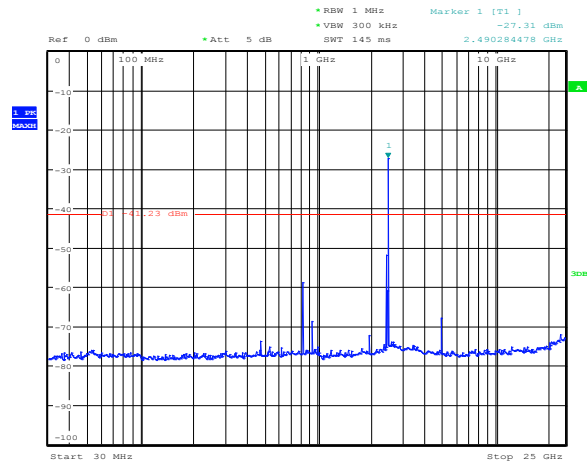

Date: 18.SEP.2017 09:05:58

Figure 8.5-6: Conducted spurious emissions outside restricted bands, high channel

8.5.4 Test data, continued

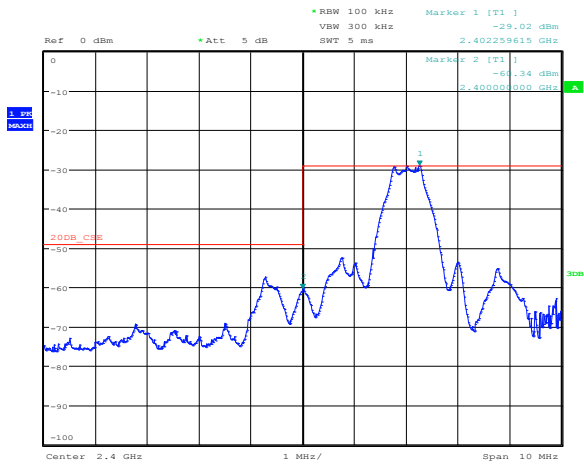

Date: 18.SEP.2017 09:16:35

Figure 8.5-7: Conducted spurious emissions outside restricted bands at the lower band edge

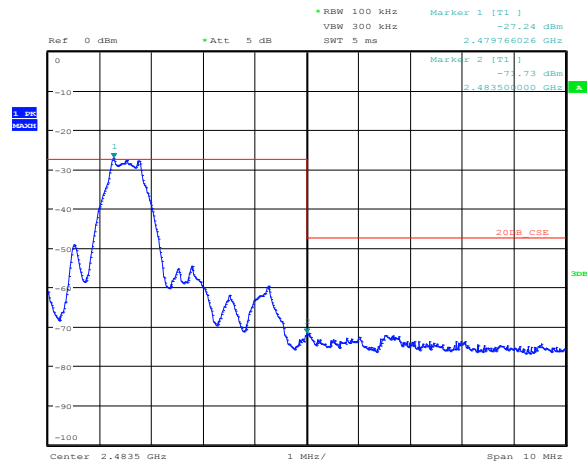

Date: 18.SEP.2017 09:19:20

Figure 8.5-8: Conducted spurious emissions outside restricted bands at the upper band edge

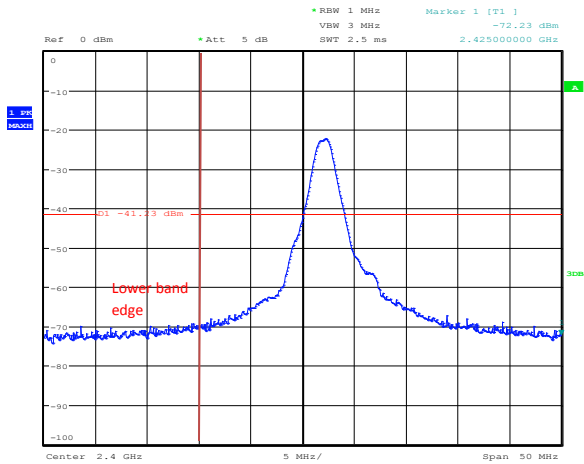

Date: 18.SEP.2017 09:23:54

Figure 8.5-9: Conducted spurious emissions within restricted bands at the lower band edge

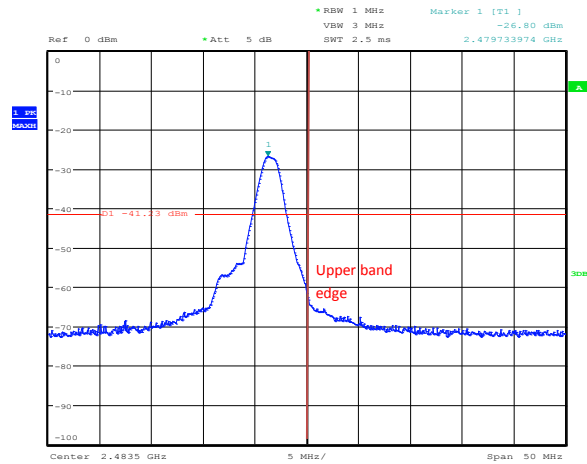

Date: 18.SEP.2017 09:21:43

Figure 8.5-10: Conducted spurious emissions within restricted bands at the upper band edge

## Section 9. Block diagrams of test set-ups

### 9.1 Radiated emissions set-up for frequencies below 1 GHz

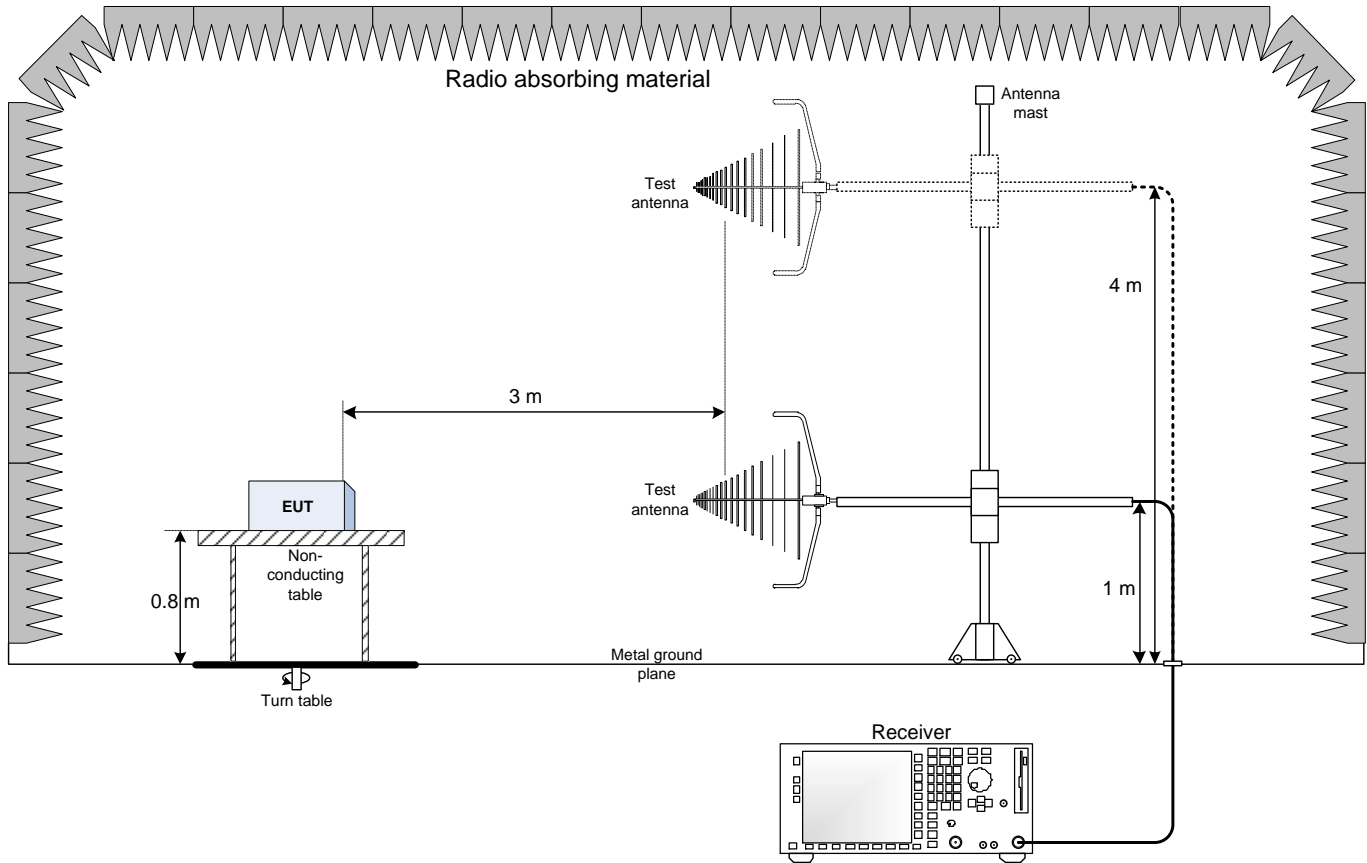

### 9.2 Radiated emissions set-up for frequencies above 1 GHz

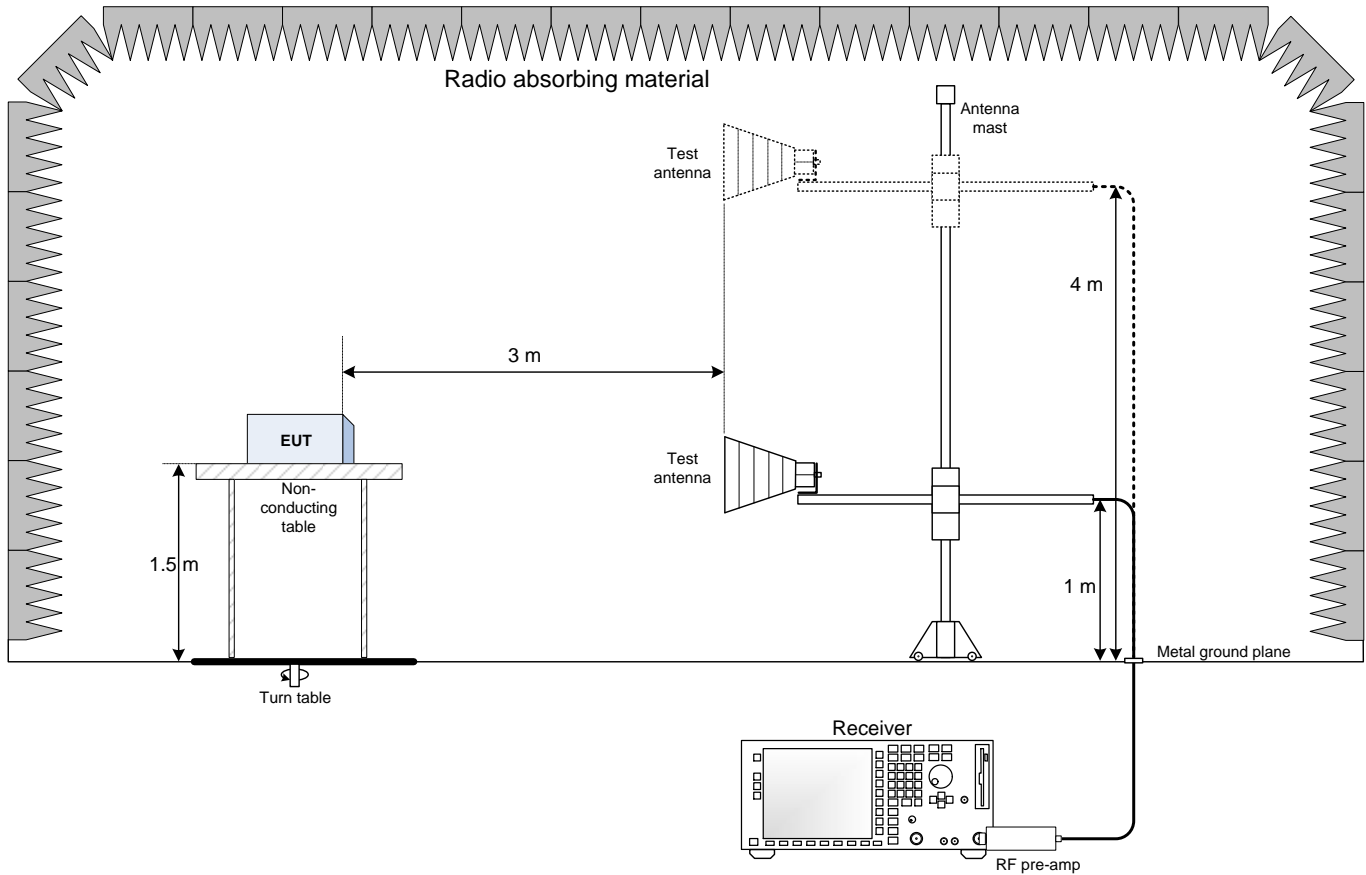

### 9.3 Conducted emissions set-up

