



# FCC TEST REPORT

According to

## FCC Rules and Regulations Part 15 Subpart C

Applicant : Amped Wireless  
\_\_\_\_\_  
Address : 13089 Peyton Dr. #C307 Chino Hills CA 91709  
\_\_\_\_\_  
Equipment : High Power Wireless-N 600mW Smart Router  
\_\_\_\_\_  
Model No. : R10000  
\_\_\_\_\_  
Trade Name : Amped Wireless  
\_\_\_\_\_  
FCC ID : ZTT-R10000-2  
\_\_\_\_\_

- The test result refers exclusively to the test presented test model / sample.,
- Without written approval of **CerpPASS Technology Corp.**, the test report shall not be reproduced except in full.
- The EUT is also considered as a kind of computer peripheral, because the connection to computer is necessary for typical use. It has been verified to comply with the requirements of FCC Part 15, Subpart B, Class B (DoC). The test report has been issued separately.



## Contents

<b>1. Report of Measurements and Examinations .....</b>	<b>6</b>
1.1 List of Measurements and Examinations .....	6
<b>2. Test Configuration of Equipment under Test .....</b>	<b>7</b>
2.1 Feature of Equipment under Test.....	7
2.2 Carrier Frequency of Channels.....	7
2.3 Test Mode and Test Software.....	8
2.4 Description of Test System .....	8
2.5 General Information of Test.....	9
2.6 Measurement Uncertainty .....	9
<b>3. Antenna Requirements .....</b>	<b>10</b>
3.1 Standard Applicable .....	10
3.2 Antenna Construction and Directional Gain.....	10
<b>4. Test of Conducted Emission .....</b>	<b>11</b>
4.1 Test Limit.....	11
4.2 Test Procedures .....	11
4.3 Typical Test Setup.....	12
4.4 Measurement Equipment.....	12
4.5 Test Result and Data.....	13
4.6 Test Photographs .....	19
<b>5. Test of Radiated Emission .....</b>	<b>20</b>
5.1 Test Limit.....	20
5.2 Test Procedures .....	20
5.3 Typical Test Setup .....	21
5.4 Measurement Equipment.....	21
5.5 Test Result and Data.....	22
5.6 Test Photographs (30MHz~1000MHz).....	58
5.7 Test Photographs (1000MHz~25000MHz).....	59
<b>6. 6dB Bandwidth Measurement Data .....</b>	<b>60</b>
6.1 Test Limit.....	60
6.2 Test Procedures .....	60
6.3 Test Setup Layout .....	60
6.4 Measurement Equipment.....	60
6.5 Test Result and Data.....	60
<b>7. Maximum Peak and Average Output Power .....</b>	<b>73</b>
7.1 Test Limit.....	73
7.2 Test Procedures .....	73
7.3 Test Setup Layout .....	73
7.4 Measurement Equipment.....	73
7.5 Test Result and Data.....	74
<b>8. Power Spectral Density .....</b>	<b>76</b>
8.1 Test Limit.....	76
8.2 Test Procedures .....	76
8.3 Test Setup Layout .....	76



8.4 Measurement Equipment..... 76

8.5 Test Result and Data..... 76

**9. Band Edges Measurement..... 89**

9.1 Test Limit..... 89

9.2 Test Procedure..... 89

9.3 Test Setup Layout ..... 89

9.4 Measurement Equipment..... 89

9.5 Test Result and Data..... 89

9.6 Restrict Band Emission Measurement Data ..... 106

**10. Restricted Bands of Operation..... 108**

10.1 Labeling Requirement..... 108

**Appendix A. Photographs of EUT.....A1 ~ A6**



History of this test report

ORIGINAL.

Additional attachment as following record:

Attachment No.	Issue Date	Description
TEF11309132	Oct. 17, 2013	Original.



# CERTIFICATE OF COMPLIANCE

According to

## FCC Rules and Regulations

### Part 15 Subpart C

Applicant : Amped Wireless  
Address : 13089 Peyton Dr. #C307 Chino Hills CA 91709  
Equipment : High Power Wireless-N 600mW Smart Router  
Model No. : R10000  
FCC ID : ZTT-R10000-2

**I HEREBY CERTIFY THAT :**

The measurements shown in this test report were made in accordance with the procedures given in **ANSI C63.4** The equipment was **passed** the test performed according to **FCC Rules and Regulations Part 15 Subpart C (2010)**.

The test was carried out on Oct. 04, 2013 at CerpPASS Technology Corp.

Approval by :

Hill Chen

EMC/RF B.U. Assistant Manager

Test Engineer:

Tom Tai

Engineer



# 1. Report of Measurements and Examinations

## 1.1 List of Measurements and Examinations

FCC Rule	Description of Test	Result
15.203	. Antenna Requirement	Pass
15.207	. Conducted Emission	Pass
15.209 15.247(d)	. Radiated Emission	Pass
15.247(a)(2)	. 6dB Bandwidth	Pass
15.247(b)	. Maximum Peak Output Power	Pass
15.247(d)	. 100kHz Bandwidth of Frequency Band Edges	Pass
15.247(e)	. Power Spectral Density	Pass
1.1307 1.1310 2.1091 2.1093	. RF Exposure Compliance	Pass



## 2. Test Configuration of Equipment under Test

### 2.1 Feature of Equipment under Test

RF Spec.

WLAN Standard	IEEE 802.11b/g/n
Data Rate	802.11b: 11, 5.5, 2 and 1 Mbps with auto-rate fall back 802.11g: 54, 48, 36, 24, 18, 12, 9 & 6Mbps 802.11n(20MHz): up to 144Mbps 802.11n(40MHz): up to 300Mbps
Modulation	802.11b: DSSS(CCK, DQPSK, DBPSK) 802.11g/n: OFDM(DBPSK, DQPSK, OFDM, BPSK, QPSK, 16-QAM, 64-QAM)
Operating Frequencies	2412~2462 MHz for North America 2412~2472 MHz for Europe
Frequency Band	2.400GHz ~ 2.484GHz
Channel Numbers	11 for North America 13 for Europe
Antenna	External Antenna(Dipole) Two detachable 7dBi antennas
Output Power	802.11b: up to 28 ± 1 dBm 802.11g: up to 22 ± 1 dBm 802.11n: up to 19 ± 1 dBm
Receive Sensitivity	-94dBm @ 802.11b -90dBm @ 802.11g -87dBm @ 802.11n

### 2.2 Carrier Frequency of Channels

802.11b, 802.11g, 802.11n HT 20

Channel	Frequency(MHz)	Channel	Frequency(MHz)
01	2412	07	2442
02	2417	08	2447
03	2422	09	2452
04	2427	10	2457
05	2432	11	2462
06	2437	---	---

802.11n, HT40

Channel	Frequency(MHz)	Channel	Frequency(MHz)
---	---	08	2447
---	---	09	2452
03	2422	---	---
04	2427	---	---
05	2432	---	---
06	2437	---	---
07	2442	---	---



### 2.3 Test Mode and Test Software

- a. During testing, the interface cables and equipment positions were varied according to ANSI C63.4.
- b. The complete test system included remote workstation, Notebook and EUT for RF test. The remote workstation includes Notebook.
- c. The EUT was executed to keep transmitting and receiving data via Wireless.
- d. The following test modes were performed for test:
  - 802.11b/g/n HT20: CH01: 2412MHz, CH06: 2437MHz, CH11: 2462MHz
  - 802.11n HT40: CH03: 2422MHz, CH06: 2437MHz, CH09: 2452MHz

\* Power output of data rate:

802.11b		802.11g		802.11n HT20		802.11n HT40	
Data Rate (Mbps)	Power output (dBm)	Data Rate (Mbps)	Power output (dBm)	Data Rate (Mbps)	Power output (dBm)	Data Rate (Mbps)	Power output (dBm)
11	27.81	54	27.83	130/15	27.68	270/15	27.86
5.5	27.72	48	27.81	117/14	27.67	243/14	27.79
2	27.68	36	27.77	104/13	27.61	216/13	27.83
1	27.65	24	27.76	78/12	27.65	162/12	27.84
---	---	18	27.76	52/11	27.59	108/11	27.82
---	---	12	27.75	39/10	27.59	81/10	27.84
---	---	9	27.78	26/9	27.51	54/9	27.78
---	---	6	27.72	13/8	27.52	27/8	27.81
---	---	---	---	65/7	27.65	135/7	27.76
---	---	---	---	58.5/6	27.54	121.5/6	27.69
---	---	---	---	52/5	27.58	108/5	27.73
---	---	---	---	39/4	27.62	81/4	27.74
---	---	---	---	26/3	27.56	54/3	27.72
---	---	---	---	19.5/2	27.57	40.5/2	27.75
---	---	---	---	13/1	27.48	27/1	27.77
---	---	---	---	6.5/0	27.49	13.5/0	27.71

### 2.4 Description of Test System

Device	Manufacturer	Model No.	Description
Notebook	DELL	INSPIRON 510m	Power Cable, Unshielding 1.8m
Remote workstation			
Notebook	DELL	INSPIRON 510m	Power Cable, Unshielding 1.8m





## 2.5 General Information of Test

Test Site :	CerpPASS Technology Corp. 2F-11, No. 3, Yuan Qu St., (Nankang Software Park), Taipei, Taiwan 115, R.O.C.
Test Site Location (OATS2-SD) :	No.68-1, Shihbachongsi, Shihding Township, Taipei City 223, Taiwan, R.O.C.
FCC Registration Number :	TW1049, TW1061, 390316, 488071
IC Registration Number :	4934B-1, 4934D-1
VCCI Registration Number :	T-1173 for Telecommunication Test C-4139 for Conducted emission test R-3428 for Radiated emission test G-97 for Radiated emission test above 1GHz
Frequency Range Investigated:	Conducted: from 150kHz to 30MHz Radiation: from 30MHz to 25,000MHz
Test Distance:	The test distance of radiated emission from antenna to EUT is 3 M.
Laboratory Accreditation :	

## 2.6 Measurement Uncertainty

Measurement Item	Uncertainty
Radiated emission	$\pm 4.11$ dB
Peak Output Power(conducted)	$\pm 1.38$ dB
Peak Output Power(Radiated)	$\pm 1.70$ dB
Power Spectral Density	$\pm 1.39$ dB
Radiated emission(3m)	$\pm 4.11$ dB
Radiated emission(10m)	$\pm 3.89$ dB



### 3. Antenna Requirements

#### 3.1 Standard Applicable

For intentional device, according to FCC 47 CFR Section 15.203, an intentional radiator shall be designed to ensure that no antenna other than that furnished by the responsible party shall be used with the device.

And according to FCC 47 CFR Section 15.247 (b), if transmitting antennas of directional gain greater than 6dBi are used, the power shall be reduced by the amount in dB that the directional gain of the antenna exceeds 6dBi.

#### 3.2 Antenna Construction and Directional Gain

ANT R

Antenna Type: Dipole Antenna

Antenna Gain: 5 dBi

Connector: MHF (Reverse Polarity meets FCC part 15. 203 Requirement)

ANT L

Antenna Type: Dipole Antenna

Antenna Gain: 5 dBi

Connector: MHF (Reverse Polarity meets FCC part 15. 203 Requirement)

Note: Directional gain =  $G_{ANT} + 10 \log(N)$  dBi =  $5 + 10 \log(2) = 8.01$  (dBi)



## 4. Test of Conducted Emission

### 4.1 Test Limit

Conducted Emissions were measured from 150 kHz to 30 MHz with a bandwidth of 9 KHz on the 120 VAC power and return leads of the EUT according to the methods defined in ANSI C63.4-2009 Section 3.1. The EUT was placed on a nonmetallic stand in a shielded room 0.8 meters above the ground plane as shown in section 2.2. The interface cables and equipment positioning were varied within limits of reasonable applications to determine the position produced maximum conducted emissions.

Frequency (MHz)	Quasi Peak (dB $\mu$ V)	Average (dB $\mu$ V)
0.15 – 0.5	66-56*	56-46*
0.5 – 5.0	56	46
5.0 – 30.0	60	50

\*Decreases with the logarithm of the frequency.

### 4.2 Test Procedures

- a. The EUT was placed 0.4 meter from the conducting wall of the shielding room was kept at least 80 centimeters from any other grounded conducting surface.
- b. Connect EUT to the power mains through a line impedance stabilization network (LISN).
- c. All the support units are connecting to the other LISN.
- d. The LISN provides 50 ohm coupling impedance for the measuring instrument.
- e. The FCC states that a 50 ohm, 50 micro-Henry LISN should be used.
- f. Both sides of AC line were checked for maximum conducted interference.
- g. The frequency range from 150 kHz to 30 MHz was searched.
- h. Set the test-receiver system to Peak Detect Function and Specified Bandwidth with Maximum Hold Mode.



### 4.3 Typical Test Setup

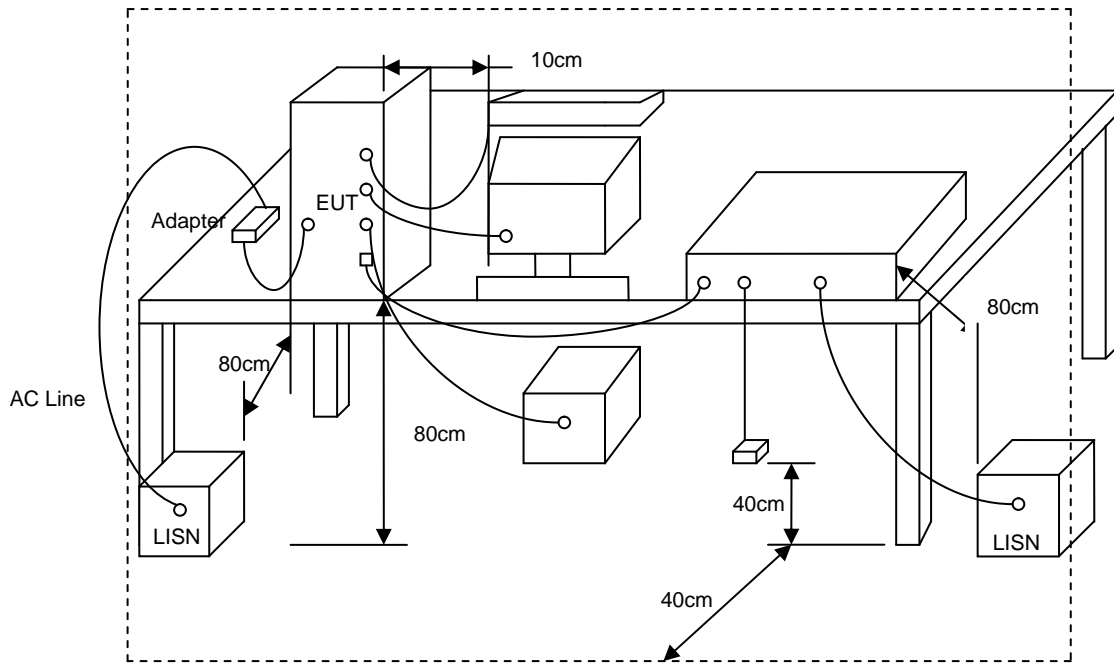

### 4.4 Measurement Equipment

Instrument/ Ancillary	Model No.	Manufacturer	Serial No.	Calibration Date	Valid Date
EMI Receiver	R&S	ESCI	100821	2012/12/24	2013/12/23
LISN	Schwarzbeck	NSLK 8127	8127-516	2013/03/08	2014/03/07
LISN	Schwarzbeck	NSLK 8127	8127-568	2013/08/26	2014/08/25
Attenuator	HAMEG	HZ560	-----	2013/03/07	2014/03/06



### 4.5 Test Result and Data

Power	: AC 120V	Pol/Phase	: LINE
Test Mode 1	: 802.11g, CH1	Temperature	: 24 °C
Test Date	: Oct. 09, 2013	Humidity	: 58 %

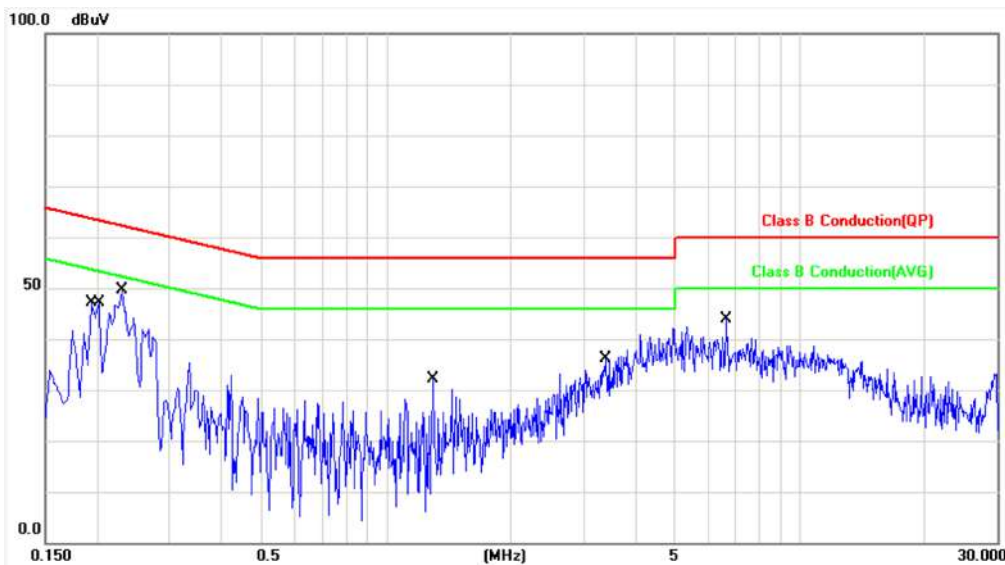

No.	Frequency (MHz)	Factor (dBuV)	Reading (dBuV)	Level (dBuV)	Limit (dBuV)	Margin (dB)	Detector	P/F
1	0.1940	0.19	45.53	45.72	63.86	-18.14	QP	P
2	0.1940	0.19	32.88	33.07	53.86	-20.79	AVG	P
3	0.2020	0.19	47.46	47.65	63.52	-15.87	QP	P
4	0.2020	0.19	34.74	34.93	53.52	-18.59	AVG	P
5	0.2300	0.19	46.23	46.42	62.45	-16.03	QP	P
6	0.2300	0.19	33.79	33.98	52.45	-18.47	AVG	P
7	1.2980	0.25	20.14	20.39	56.00	-35.61	QP	P
8	1.2980	0.25	9.22	9.47	46.00	-36.53	AVG	P
9	3.4100	0.35	28.33	28.68	56.00	-27.32	QP	P
10	3.4100	0.35	18.19	18.54	46.00	-27.46	AVG	P
11	6.6420	0.44	31.77	32.21	60.00	-27.79	QP	P
12	6.6420	0.44	21.43	21.87	50.00	-28.13	AVG	P

Note: Level = Reading + Factor  
Margin = Level – Limit



Power	: AC 120V	Pol/Phase	: NEUTRAL
Test Mode 1	: 802.11g, CH1	Temperature	: 24 °C
Test Date	: Oct. 09, 2013	Humidity	: 58 %

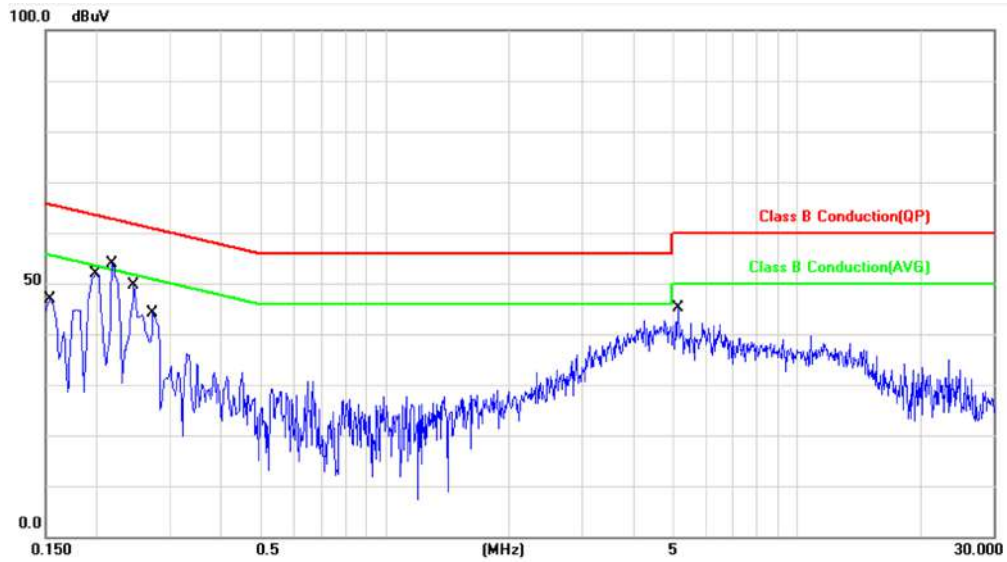

No.	Frequency (MHz)	Factor (dBuV)	Reading (dBuV)	Level (dBuV)	Limit (dBuV)	Margin (dB)	Detector	P/F
1	0.1539	0.11	45.59	45.70	65.78	-20.08	QP	P
2	0.1539	0.11	33.75	33.86	55.78	-21.92	AVG	P
3	0.1980	0.10	49.65	49.75	63.69	-13.94	QP	P
4	0.1980	0.10	40.47	40.57	53.69	-13.12	AVG	P
5	0.2180	0.10	48.87	48.97	62.89	-13.92	QP	P
6	0.2180	0.10	39.67	39.77	52.89	-13.12	AVG	P
7	0.2460	0.10	50.15	50.25	61.89	-11.64	QP	P
8	0.2460	0.10	42.69	42.79	51.89	-9.10	AVG	P
9	0.2740	0.10	42.54	42.64	60.99	-18.35	QP	P
10	0.2740	0.10	34.21	34.31	50.99	-16.68	AVG	P
11	5.1500	0.33	36.78	37.11	60.00	-22.89	QP	P
12	5.1500	0.33	27.39	27.72	50.00	-22.28	AVG	P

Note: Level = Reading + Factor  
Margin = Level – Limit



Power	: AC 120V	Pol/Phase	: LINE
Test Mode 2	: 802.11n HT20, CH1	Temperature	: 24 °C
Test Date	: Oct. 09, 2013	Humidity	: 58 %

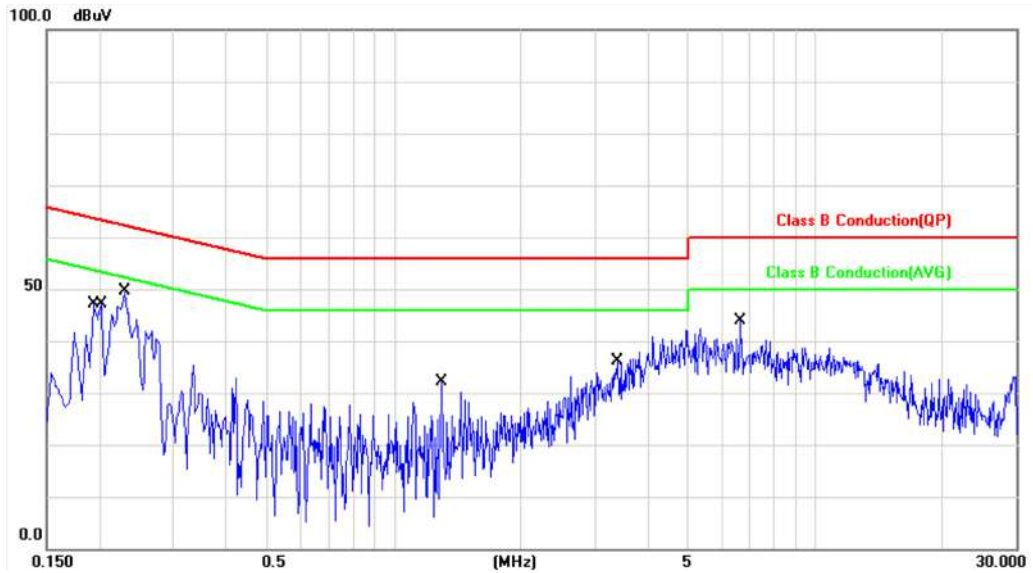

No.	Frequency (MHz)	Factor (dBuV)	Reading (dBuV)	Level (dBuV)	Limit (dBuV)	Margin (dB)	Detector	P/F
1	0.1940	0.19	45.64	45.83	63.86	-18.03	QP	P
2	0.1940	0.19	32.95	33.14	53.86	-20.72	AVG	P
3	0.2020	0.19	47.35	47.54	63.52	-15.98	QP	P
4	0.2020	0.19	34.85	35.04	53.52	-18.48	AVG	P
5	0.2300	0.19	46.49	46.68	62.45	-15.77	QP	P
6	0.2300	0.19	33.62	33.81	52.45	-18.64	AVG	P
7	1.2980	0.25	20.33	20.58	56.00	-35.42	QP	P
8	1.2980	0.25	9.51	9.76	46.00	-36.24	AVG	P
9	3.4100	0.35	28.16	28.51	56.00	-27.49	QP	P
10	3.4100	0.35	18.24	18.59	46.00	-27.41	AVG	P
11	6.6420	0.44	31.66	32.10	60.00	-27.90	QP	P
12	6.6420	0.44	21.51	21.95	50.00	-28.05	AVG	P

Note: Level = Reading + Factor  
Margin = Level – Limit



Power	: AC 120V	Pol/Phase	: NEUTRAL
Test Mode 2	: 802.11n HT20, CH1	Temperature	: 24 °C
Test Date	: Oct. 09, 2013	Humidity	: 58 %

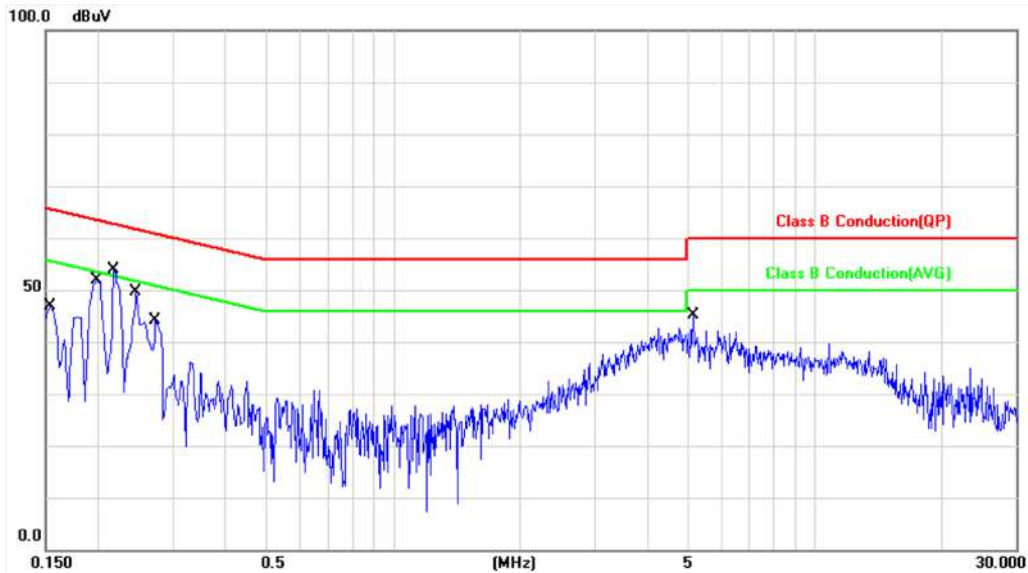

No.	Frequency (MHz)	Factor (dBuV)	Reading (dBuV)	Level (dBuV)	Limit (dBuV)	Margin (dB)	Detector	P/F
1	0.1539	0.11	45.34	45.45	65.78	-20.33	QP	P
2	0.1539	0.11	33.63	33.74	55.78	-22.04	AVG	P
3	0.1980	0.10	49.73	49.83	63.69	-13.86	QP	P
4	0.1980	0.10	40.55	40.65	53.69	-13.04	AVG	P
5	0.2180	0.10	48.69	48.79	62.89	-14.10	QP	P
6	0.2180	0.10	39.61	39.71	52.89	-13.18	AVG	P
7	0.2460	0.10	50.29	50.39	61.89	-11.50	QP	P
8	0.2460	0.10	42.72	42.82	51.89	-9.07	AVG	P
9	0.2740	0.10	42.61	42.71	60.99	-18.28	QP	P
10	0.2740	0.10	34.30	34.40	50.99	-16.59	AVG	P
11	5.1500	0.33	36.53	36.86	60.00	-23.14	QP	P
12	5.1500	0.33	27.44	27.77	50.00	-22.23	AVG	P

Note: Level = Reading + Factor  
Margin = Level – Limit





Power	: AC 120V	Pol/Phase	: LINE
Test Mode 3	: 802.11n HT40, CH3	Temperature	: 24 °C
Test Date	: Oct. 09, 2013	Humidity	: 58 %

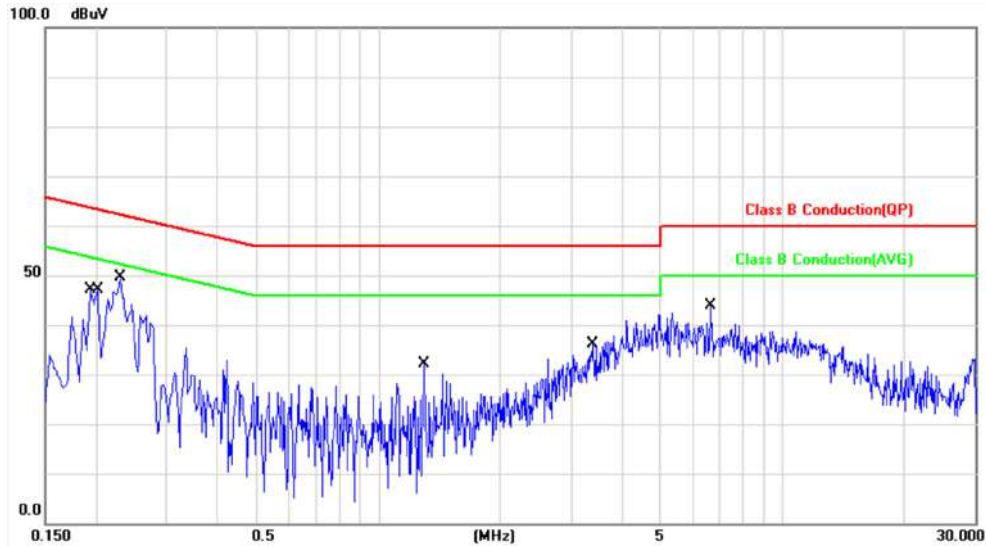

No.	Frequency (MHz)	Factor (dBuV)	Reading (dBuV)	Level (dBuV)	Limit (dBuV)	Margin (dB)	Detector	P/F
1	0.1940	0.19	45.62	45.81	63.86	-18.05	QP	P
2	0.1940	0.19	32.77	32.96	53.86	-20.90	AVG	P
3	0.2020	0.19	47.59	47.78	63.52	-15.74	QP	P
4	0.2020	0.19	34.67	34.86	53.52	-18.66	AVG	P
5	0.2300	0.19	46.33	46.52	62.45	-15.93	QP	P
6	0.2300	0.19	33.88	34.07	52.45	-18.38	AVG	P
7	1.2980	0.25	20.33	20.58	56.00	-35.42	QP	P
8	1.2980	0.25	9.41	9.66	46.00	-36.34	AVG	P
9	3.4100	0.35	28.51	28.86	56.00	-27.14	QP	P
10	3.4100	0.35	18.21	18.56	46.00	-27.44	AVG	P
11	6.6420	0.44	31.64	32.08	60.00	-27.92	QP	P
12	6.6420	0.44	21.52	21.96	50.00	-28.04	AVG	P

Note: Level = Reading + Factor  
Margin = Level – Limit



Power	: AC 120V	Pol/Phase	: NEUTRAL
Test Mode 3	: 802.11n HT40, CH3	Temperature	: 24 °C
Test Date	: Oct. 09, 2013	Humidity	: 58 %



No.	Frequency (MHz)	Factor (dBuV)	Reading (dBuV)	Level (dBuV)	Limit (dBuV)	Margin (dB)	Detector	P/F
1	0.1539	0.11	45.69	45.80	65.78	-19.98	QP	P
2	0.1539	0.11	33.64	33.75	55.78	-22.03	AVG	P
3	0.1980	0.10	49.54	49.64	63.69	-14.05	QP	P
4	0.1980	0.10	40.50	40.60	53.69	-13.09	AVG	P
5	0.2180	0.10	48.75	48.85	62.89	-14.04	QP	P
6	0.2180	0.10	39.74	39.84	52.89	-13.05	AVG	P
7	0.2460	0.10	50.23	50.33	61.89	-11.56	QP	P
8	0.2460	0.10	42.79	42.89	51.89	-9.00	AVG	P
9	0.2740	0.10	42.65	42.75	60.99	-18.24	QP	P
10	0.2740	0.10	34.32	34.42	50.99	-16.57	AVG	P
11	5.1500	0.33	36.68	37.01	60.00	-22.99	QP	P
12	5.1500	0.33	27.40	27.73	50.00	-22.27	AVG	P

Note: Level = Reading + Factor  
Margin = Level – Limit



## 5. Test of Radiated Emission

### 5.1 Test Limit

In any 100kHz bandwidth outside the frequency band in which the spread spectrum or digitally modulated intentional radiator is operating, the radio frequency power that is produced by the intentional radiator shall be at least 20dB below that in the 100kHz bandwidth within the band that contains the highest level of the desired power, based on either an RF conducted or a radiated measurement. If the transmitter measurement is based on the maximum conducted output power, the attenuation required under this paragraph shall be 30dB instead of 20dB. In addition, radiated emissions which fall in section 15.205(a) the restricted bands must also comply with the radiated emission limit specified in section 15.209(a).

Frequency (MHz)	Field Strength (microvolt/meter)	Measurement Distance (meters)
0.009 ~ 0.490	2400/F(kHz)	300
0.490 ~ 1.705	24000/F(kHz)	30
1.705 ~ 30.0	30	30
30 ~ 88	100	3
88 ~ 216	150	3
216 ~ 960	200	3
Above 960	500	3

### 5.2 Test Procedures

- a. The EUT was placed on a rotatable table top 0.8 meter above ground.
- b. The EUT was set 3 meters from the interference receiving antenna which was mounted on the top of a variable height antenna tower.
- c. The table was rotated 360 degrees to determine the position of the highest radiation.
- d. The antenna is a broadband antenna and its height is varied between one meter and four meters above ground to find the maximum value of the field strength both horizontal polarization and vertical polarization of the antenna are set to make the measurement.
- e. For each suspected emission the EUT was arranged to its worst case and then tune the antenna tower (from 1 M to 4 M) and turn table (from 0 degree to 360 degrees) to find the maximum reading.
- f. Set the test-receiver system to Peak or CISPR quasi-peak Detect Function and specified bandwidth with Maximum Hold Mode.
- g. If the emission level of the EUT in peak mode was 3 dB lower than the limit specified, then testing will be stopped and peak values of EUT will be reported, otherwise, the emissions which do not have 3 dB margin will be repeated one by one using the quasi-peak method and reported.
- h. For testing above 1GHz, the emission level of the EUT in peak mode was 20dB lower than average limit (that means the emission level in peak mode also complies with the limit in average mode), then testing will be stopped and peak values of EUT will be reported, otherwise, the emissions will be measured in average mode again and reported.
- i. "Cone of radiation" has been considered to be 3dB bandwidth of the measurement antenna.

### 5.3 Typical Test Setup

For radiated emissions below 30MHz

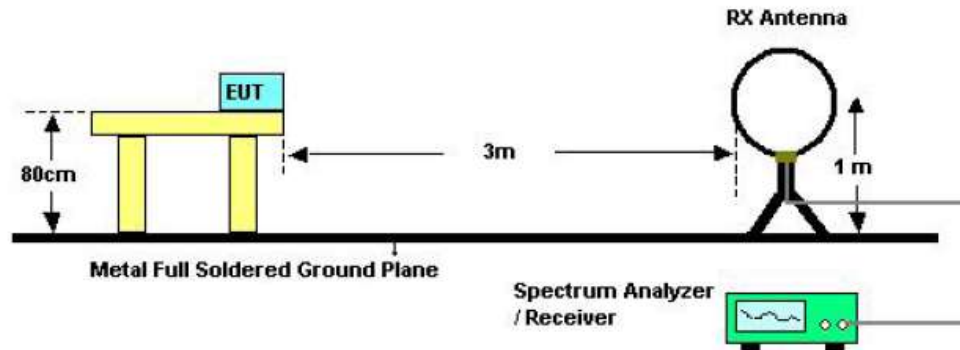

For radiated emissions above 30MHz

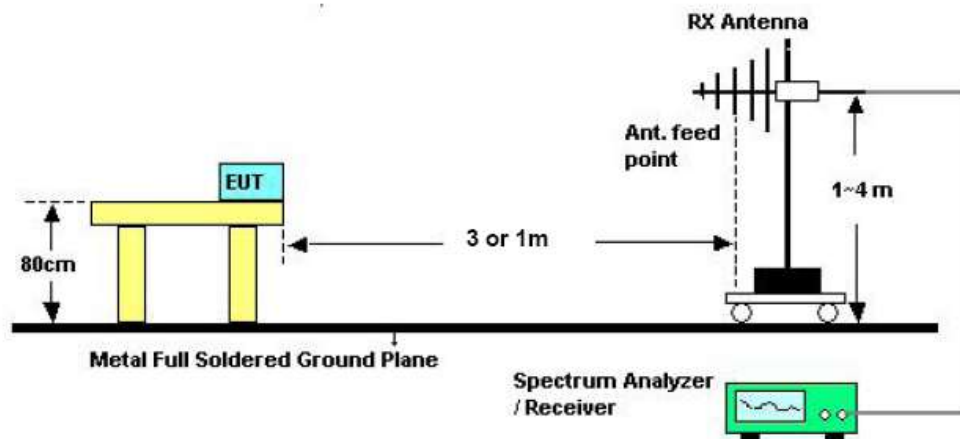

Above 10 GHz shall be extrapolated to the specified distance using an extrapolation factor of 20 dB/decade from 3m to 1m.

Distance extrapolation factor =  $20 \log (\text{specific distance [3m]} / \text{test distance [1m]})$  (dB);

Limit line = specific limits (dBuV) + distance extrapolation factor [9.54 dB].

### 5.4 Measurement Equipment

Instrument/Ancillary	Manufacturer	Model No.	Serial No.	Calibration Date	Valid Date
Amplifier	Agilent	8447D	2944A10539	2013/03/13	2014/03/12
Bilog Antenna	Schaffner	CBL6112B	2840	2013/03/27	2014/03/26
EMI Receiver	R&S	ESCI	101200	2013/09/07	2014/09/06
SPECTRUM ANALYZER	R&S	FSP40	100219	2013/09/14	2014/09/13
HORN ANTENNA	EMCO	3115	31589	2013/03/18	2014/03/17
PREAMPLIFIER	AGILENT	8449B	3008A01954	2013/03/07	2014/03/06



5.5 Test Result and Data

Power	: AC 120V	Pol/Phase	: VERTICAL
Test Mode 1	: 802.11g, CH1	Temperature	: 25 °C
Memo	:	Humidity	: 65 %

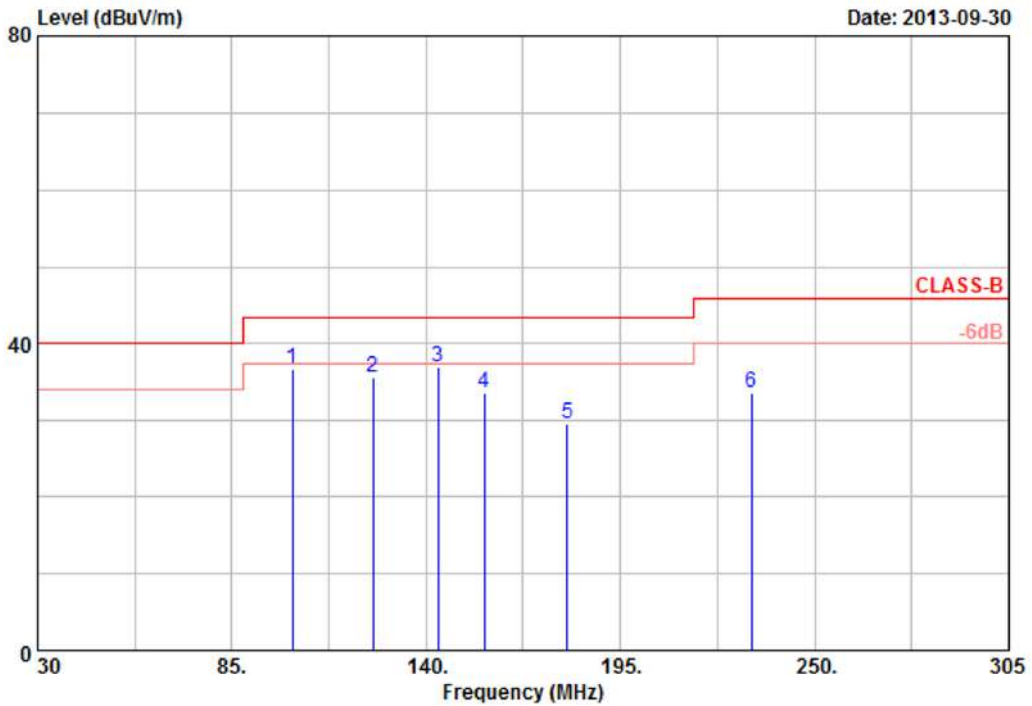

Item	Freq	Read Value	Factor	Result	Limit	Margin	Remark	Ant Pos	Tab Pos
	MHz	dBuV	dB/m	dBuV/m	dBuV/m	dB		cm	Deg
1	102.05	45.09	-8.39	36.70	43.50	-6.80	Peak	100	360
2	124.88	40.50	-4.91	35.59	43.50	-7.91	Peak	100	360
3	143.30	45.53	-8.50	37.03	43.50	-6.47	Peak	100	360
4	156.50	46.01	-12.27	33.74	43.50	-9.76	Peak	100	360
5	179.88	34.66	-5.06	29.60	43.50	-13.90	Peak	100	360
6	232.13	41.59	-7.84	33.75	46.00	-12.25	Peak	100	360

Notes:

1. Result = Read Value + Factor
2. Factor = Antenna Factor + Cable Loss - Amplifier
3. The resolution bandwidth of test receiver/spectrum analyzer is 120KHz and video bandwidth is 300kHz for Peak detection and Quasi-peak detection at frequency below 1GHz.
4. All below 1GHz configurations are pretested among available 802.11b/g/n modes and found that the worst cases are on channel 1 of 802.11g & n20 mode and Channel 3 for n40 mode. Only worst case data concluded above were presented in this test report.
5. The data is worse case.



Power	: AC 120V	Pol/Phase	: VERTICAL
Test Mode 1	: 802.11g, CH1	Temperature	: 25 °C
Memo	:	Humidity	: 65 %

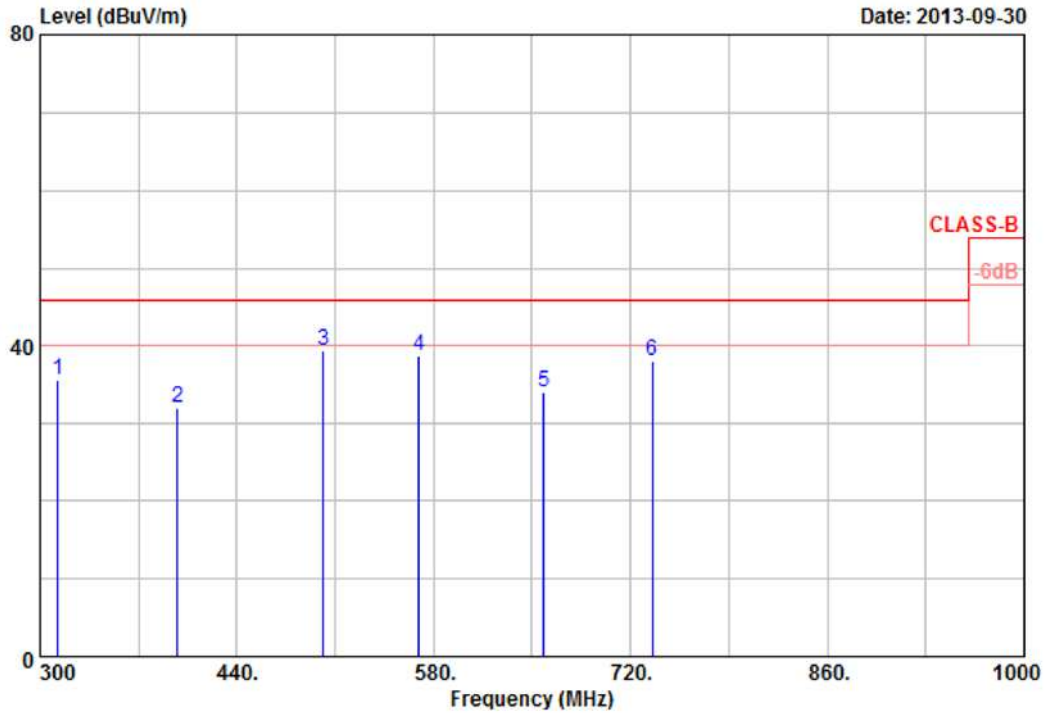

Item	Freq MHz	Read Value dBuV	Factor dB/m	Result dBuV/m	Limit dBuV/m	Margin dB	Remark	Ant Pos cm	Tab Pos Deg
1	312.60	45.46	-9.75	35.71	46.00	-10.29	Peak	100	0
2	398.00	38.17	-6.09	32.08	46.00	-13.92	Peak	100	0
3	501.60	44.33	-4.99	39.34	46.00	-6.66	Peak	100	0
4	569.50	31.08	7.60	38.68	46.00	-7.32	Peak	100	0
5	658.40	35.16	-1.01	34.15	46.00	-11.85	Peak	100	0
6	735.40	31.45	6.62	38.07	46.00	-7.93	Peak	100	0

Notes:

1. Result = Read Value + Factor
2. Factor = Antenna Factor + Cable Loss - Amplifier
3. The resolution bandwidth of test receiver/spectrum analyzer is 120KHz and video bandwidth is 300kHz for Peak detection and Quasi-peak detection at frequency below 1GHz.
4. All below 1GHz configurations are pretested among available 802.11b/g/n modes and found that the worst cases are on channel 1 of 802.11g & n20 mode and Channel 3 for n40 mode. Only worst case data concluded above were presented in this test report.
5. The data is worse case.





Power	: AC 120V	Pol/Phase	: HORIZONTAL
Test Mode 1	: 802.11g, CH1	Temperature	: 25 °C
Memo	:	Humidity	: 65 %

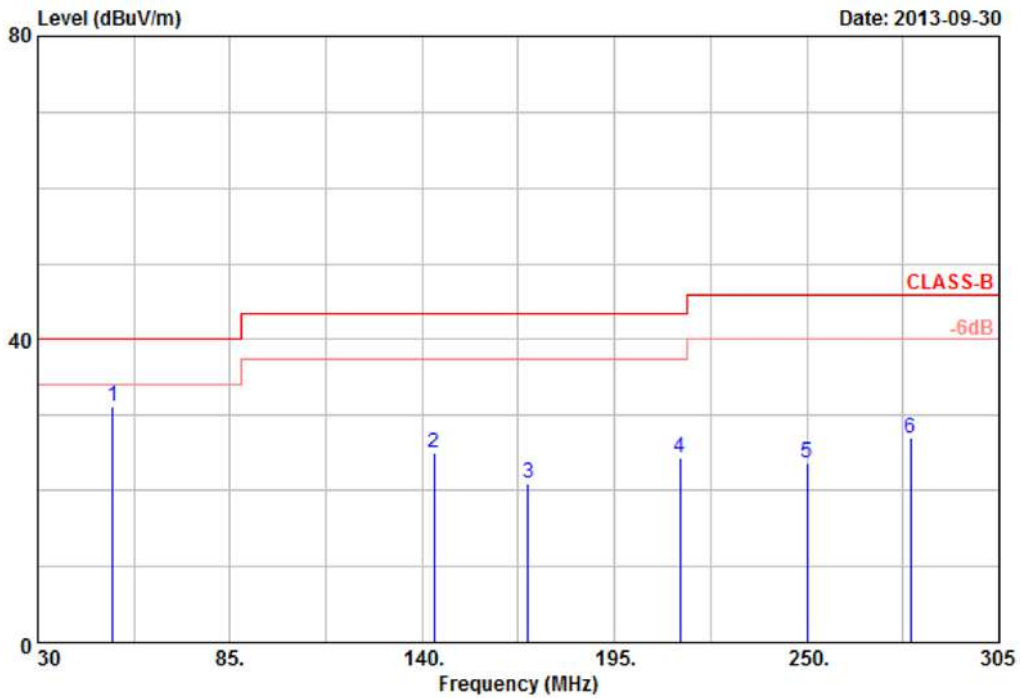

Item	Freq	Read Value	Factor	Result	Limit	Margin	Remark	Ant Pos	Tab Pos
	MHz	dBuV	dB/m	dBuV/m	dBuV/m	dB		cm	Deg
1	51.45	41.10	-9.82	31.28	40.00	-8.72	Peak	100	360
2	143.30	39.61	-14.65	24.96	43.50	-18.54	Peak	100	360
3	170.25	32.29	-11.29	21.00	43.50	-22.50	Peak	100	360
4	213.70	41.00	-16.80	24.20	43.50	-19.30	Peak	100	360
5	250.00	37.16	-13.52	23.64	46.00	-22.36	Peak	100	360
6	279.70	41.26	-14.24	27.02	46.00	-18.98	Peak	100	360

Notes:

1. Result = Read Value + Factor
2. Factor = Antenna Factor + Cable Loss - Amplifier
3. The resolution bandwidth of test receiver/spectrum analyzer is 120KHz and video bandwidth is 300kHz for Peak detection and Quasi-peak detection at frequency below 1GHz.
4. All below 1GHz configurations are pretested among available 802.11b/g/n modes and found that the worst cases are on channel 1 of 802.11g & n20 mode and Channel 3 for n40 mode. Only worst case data concluded above were presented in this test report.
5. The data is worse case.



Power	: AC 120V	Pol/Phase	: HORIZONTAL
Test Mode 1	: 802.11g, CH1	Temperature	: 25 °C
Memo	:	Humidity	: 65 %

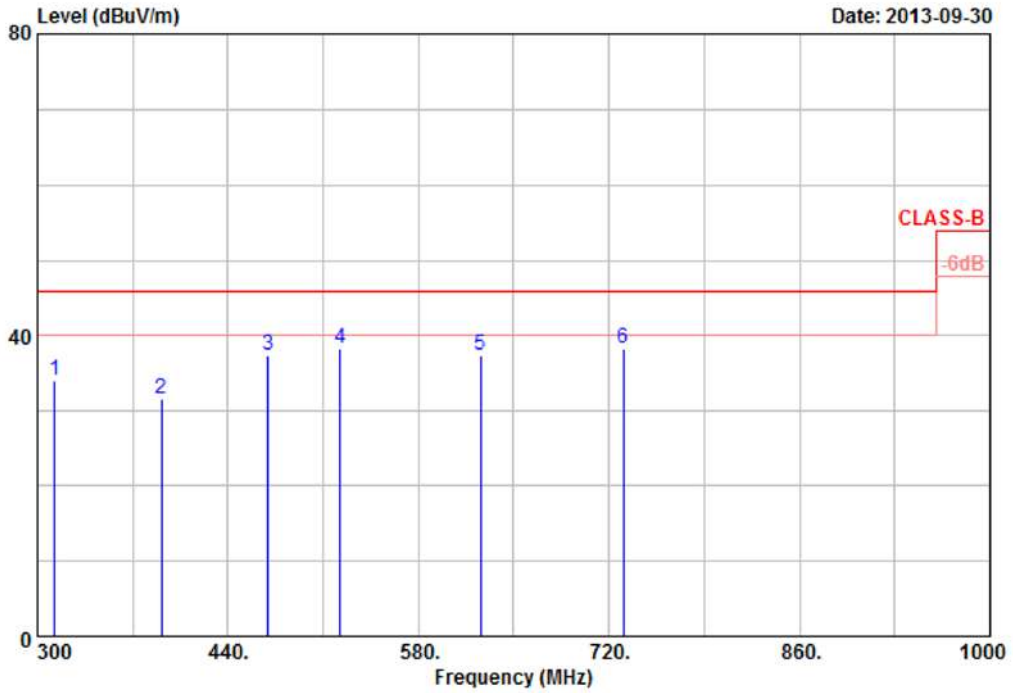

Item	Freq	Read Value	Factor	Result	Limit	Margin	Remark	Ant Pos	Tab Pos
	MHz	dBuV	dB/m	dBuV/m	dBuV/m	dB		cm	Deg
1	312.60	46.61	-12.58	34.03	46.00	-11.97	Peak	100	0
2	391.00	41.69	-10.02	31.67	46.00	-14.33	Peak	100	0
3	469.40	42.73	-5.27	37.46	46.00	-8.54	Peak	100	0
4	522.60	37.12	1.30	38.42	46.00	-7.58	Peak	100	0
5	625.50	33.28	4.23	37.51	46.00	-8.49	Peak	100	0
6	730.50	34.34	4.09	38.43	46.00	-7.57	Peak	100	0

Notes:

1. Result = Read Value + Factor
2. Factor = Antenna Factor + Cable Loss - Amplifier
3. The resolution bandwidth of test receiver/spectrum analyzer is 120KHz and video bandwidth is 300kHz for Peak detection and Quasi-peak detection at frequency below 1GHz.
4. All below 1GHz configurations are pretested among available 802.11b/g/n modes and found that the worst cases are on channel 1 of 802.11g & n20 mode and Channel 3 for n40 mode. Only worst case data concluded above were presented in this test report.
5. The data is worse case.





Power	: AC 120V	Pol/Phase	: VERTICAL
Test Mode 1	: 802.11b, CH1	Temperature	: 25 °C
Memo	:	Humidity	: 65 %

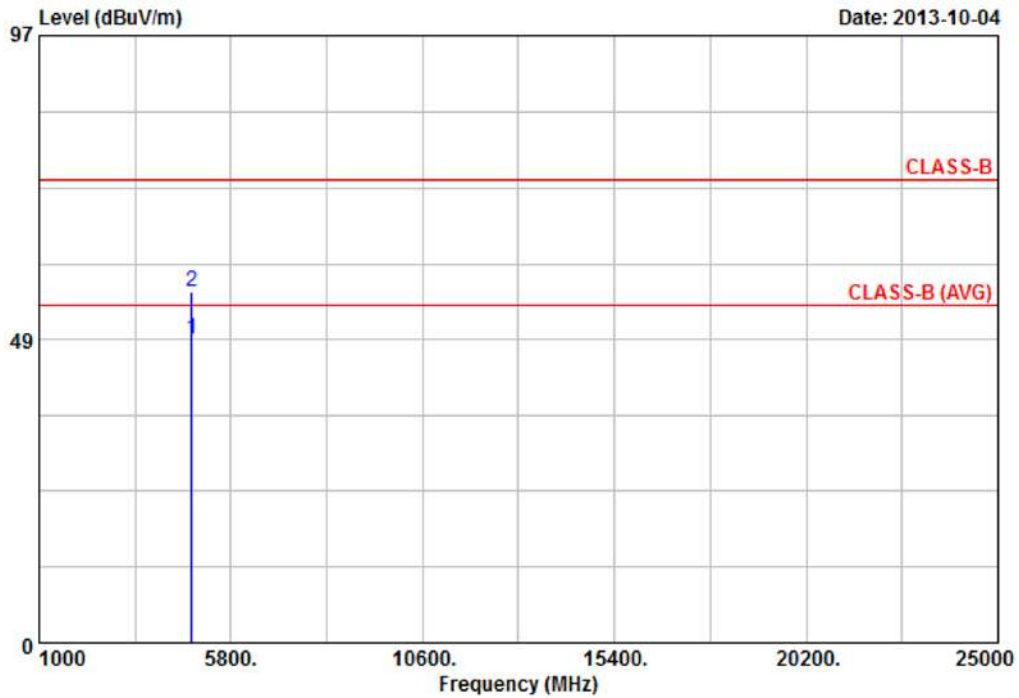

Item	Freq	Read Value	Factor	Result	Limit	Margin	Remark	Ant Pos	Tab Pos
	MHz	dBuV	dB/m	dBuV/m	dBuV/m	dB		cm	Deg
1	4823.96	42.86	5.84	48.70	54.00	-5.30	Average	100	178
2	4823.96	50.40	5.84	56.24	74.00	-17.76	Peak	100	178

Notes:

1. Result = Read Value + Factor
2. Factor = Antenna Factor + Cable Loss - Amplifier
3. The resolution bandwidth of test receiver/spectrum analyzer is 120KHz and video bandwidth is 300kHz for Peak detection and Quasi-peak detection at frequency below 1GHz.
4. The resolution bandwidth of test receiver/spectrum analyzer is 1MHz and video bandwidth is 3MHz for Peak detection at frequency above 1GHz.
5. The resolution bandwidth of test receiver/spectrum analyzer is 1MHz and video bandwidth is 3MHz (detector sample mode) for Average detection at frequency above 1GHz.
6. The other emissions is too low to be measured.
7. The data is worse case.



Power	: AC 120V	Pol/Phase	: HORIZONTAL
Test Mode 1	: 802.11b, CH1	Temperature	: 25 °C
Memo	:	Humidity	: 65 %

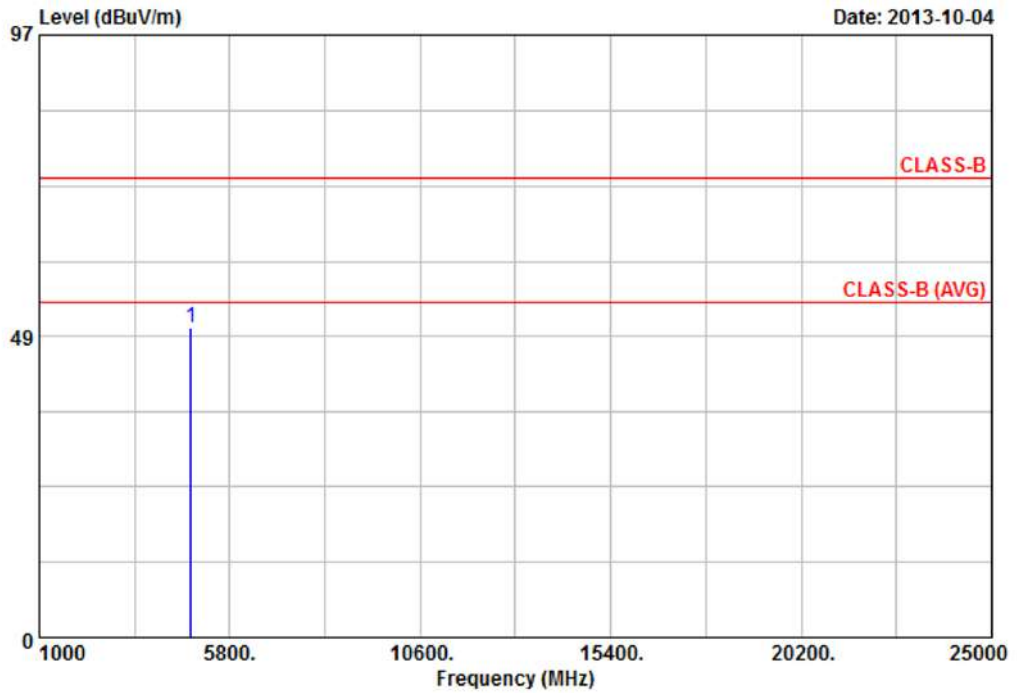

Item	Freq	Read Value	Factor	Result	Limit	Margin	Remark	Ant Pos	Tab Pos
	MHz	dBuV	dB/m	dBuV/m	dBuV/m	dB		cm	Deg
1	4824.11	45.91	4.18	50.09	74.00	-23.91	Peak	100	194

Notes:

1. Result = Read Value + Factor
2. Factor = Antenna Factor + Cable Loss - Amplifier
3. The resolution bandwidth of test receiver/spectrum analyzer is 120KHz and video bandwidth is 300kHz for Peak detection and Quasi-peak detection at frequency below 1GHz.
4. The resolution bandwidth of test receiver/spectrum analyzer is 1MHz and video bandwidth is 3MHz for Peak detection at frequency above 1GHz.
5. The resolution bandwidth of test receiver/spectrum analyzer is 1MHz and video bandwidth is 3MHz (detector sample mode) for Average detection at frequency above 1GHz.
6. The other emissions is too low to be measured.
7. The data is worse case.



Power	: AC 120V	Pol/Phase	: VERTICAL
Test Mode 1	: 802.11b, CH6	Temperature	: 25 °C
Memo	:	Humidity	: 65 %

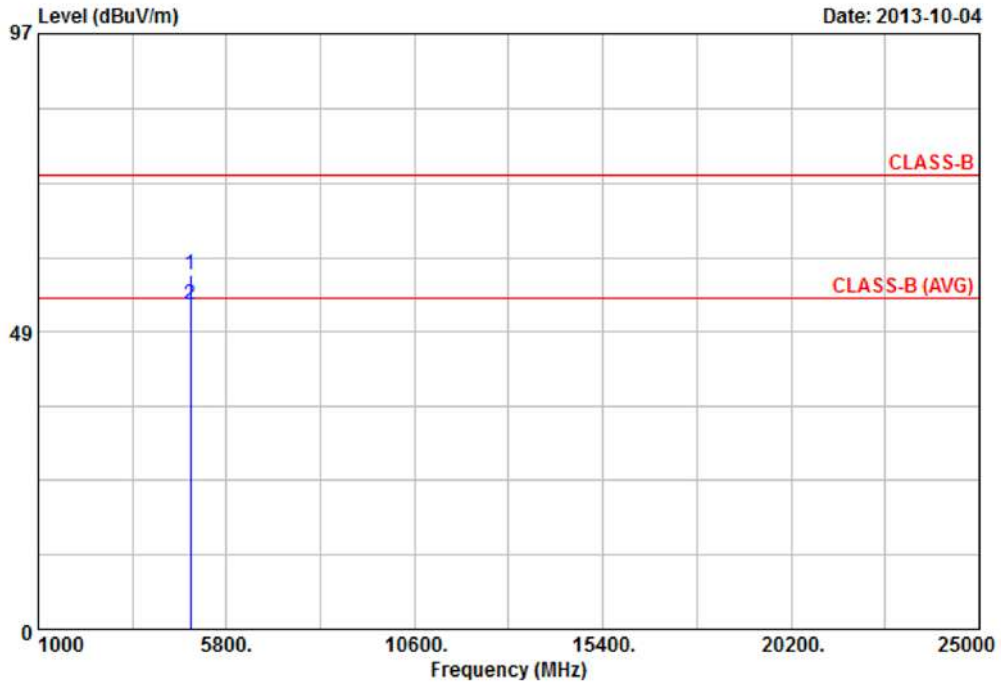

Item	Freq	Read Value	Factor	Result	Limit	Margin	Remark	Ant Pos	Tab Pos
	MHz	dBuV	dB/m	dBuV/m	dBuV/m	dB		cm	Deg
1	4873.98	50.98	6.83	57.81	74.00	-16.19	Peak	100	133
2	4873.99	46.22	6.83	53.05	54.00	-0.95	Average	100	133

Notes:

1. Result = Read Value + Factor
2. Factor = Antenna Factor + Cable Loss - Amplifier
3. The resolution bandwidth of test receiver/spectrum analyzer is 120KHz and video bandwidth is 300kHz for Peak detection and Quasi-peak detection at frequency below 1GHz.
4. The resolution bandwidth of test receiver/spectrum analyzer is 1MHz and video bandwidth is 3MHz for Peak detection at frequency above 1GHz.
5. The resolution bandwidth of test receiver/spectrum analyzer is 1MHz and video bandwidth is 3MHz (detector sample mode) for Average detection at frequency above 1GHz.
6. The other emissions is too low to be measured.
7. The data is worse case.



Power	: AC 120V	Pol/Phase	: HORIZONTAL
Test Mode 1	: 802.11b, CH6	Temperature	: 25 °C
Memo	:	Humidity	: 65 %

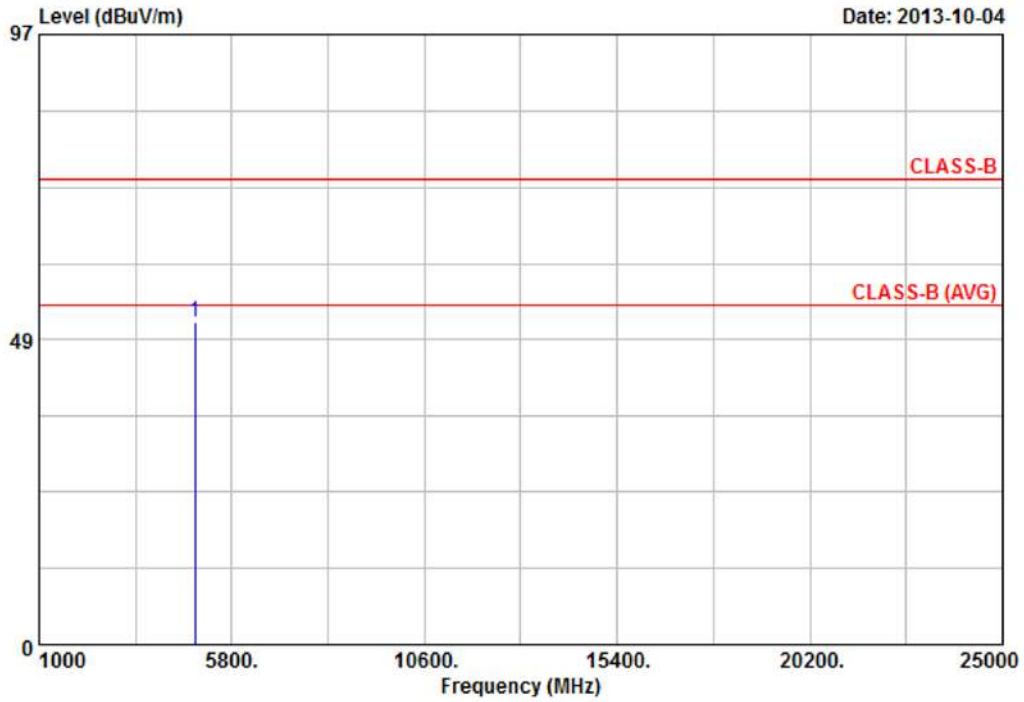

Item	Freq	Read Value	Factor	Result	Limit	Margin	Remark	Ant Pos	Tab Pos
	MHz	dBuV	dB/m	dBuV/m	dBuV/m	dB		cm	Deg
1	4874.05	46.37	4.97	51.34	74.00	-22.66	Peak	100	202

Notes:

1. Result = Read Value + Factor
2. Factor = Antenna Factor + Cable Loss - Amplifier
3. The resolution bandwidth of test receiver/spectrum analyzer is 120KHz and video bandwidth is 300kHz for Peak detection and Quasi-peak detection at frequency below 1GHz.
4. The resolution bandwidth of test receiver/spectrum analyzer is 1MHz and video bandwidth is 3MHz for Peak detection at frequency above 1GHz.
5. The resolution bandwidth of test receiver/spectrum analyzer is 1MHz and video bandwidth is 3MHz (detector sample mode) for Average detection at frequency above 1GHz.
6. The other emissions is too low to be measured.
7. The data is worse case.



Power	: AC 120V	Pol/Phase	: VERTICAL
Test Mode 1	: 802.11b, CH11	Temperature	: 25 °C
Memo	:	Humidity	: 65 %

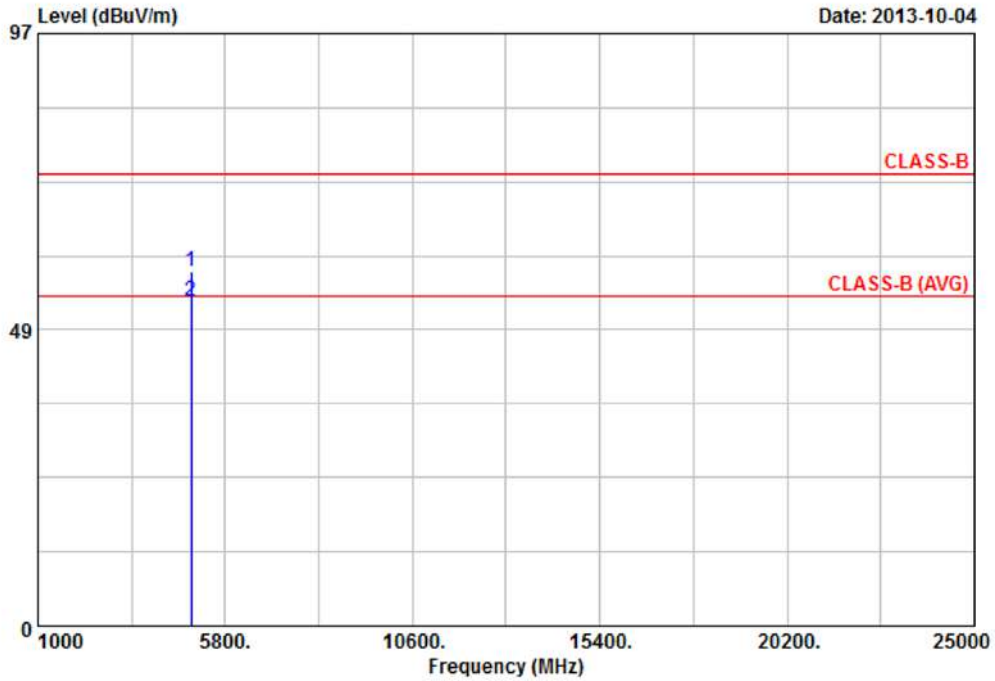

Item	Freq	Read Value	Factor	Result	Limit	Margin	Remark	Ant Pos	Tab Pos
	MHz	dBuV	dB/m	dBuV/m	dBuV/m	dB		cm	Deg
1	4923.89	50.61	7.40	58.01	74.00	-15.99	Peak	100	136
2	4923.99	45.95	7.40	53.35	54.00	-0.65	Average	100	136

Notes:

1. Result = Read Value + Factor
2. Factor = Antenna Factor + Cable Loss - Amplifier
3. The resolution bandwidth of test receiver/spectrum analyzer is 120KHz and video bandwidth is 300kHz for Peak detection and Quasi-peak detection at frequency below 1GHz.
4. The resolution bandwidth of test receiver/spectrum analyzer is 1MHz and video bandwidth is 3MHz for Peak detection at frequency above 1GHz.
5. The resolution bandwidth of test receiver/spectrum analyzer is 1MHz and video bandwidth is 3MHz (detector sample mode) for Average detection at frequency above 1GHz.
6. The other emissions is too low to be measured.
7. The data is worse case.





Power	: AC 120V	Pol/Phase	: HORIZONTAL
Test Mode 1	: 802.11b, CH11	Temperature	: 25 °C
Memo	:	Humidity	: 65 %

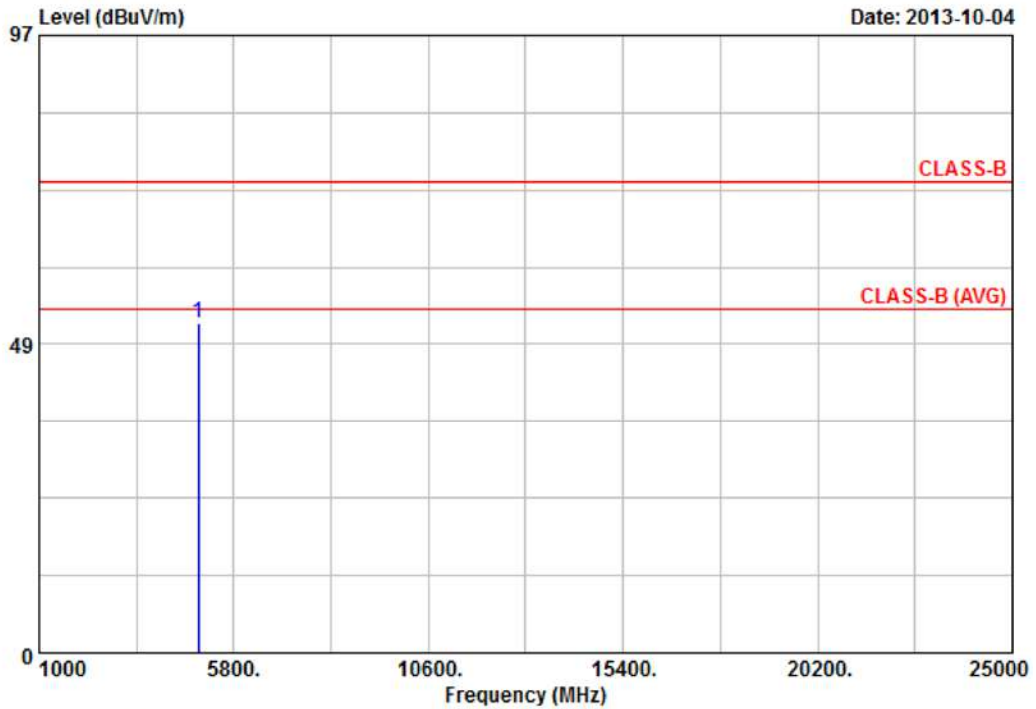

Item	Freq	Read Value	Factor	Result	Limit	Margin	Remark	Ant Pos	Tab Pos
	MHz	dBuV	dB/m	dBuV/m	dBuV/m	dB		cm	Deg
1	4923.85	46.43	5.39	51.82	74.00	-22.18	Peak	100	198

Notes:

1. Result = Read Value + Factor
2. Factor = Antenna Factor + Cable Loss - Amplifier
3. The resolution bandwidth of test receiver/spectrum analyzer is 120KHz and video bandwidth is 300kHz for Peak detection and Quasi-peak detection at frequency below 1GHz.
4. The resolution bandwidth of test receiver/spectrum analyzer is 1MHz and video bandwidth is 3MHz for Peak detection at frequency above 1GHz.
5. The resolution bandwidth of test receiver/spectrum analyzer is 1MHz and video bandwidth is 3MHz (detector sample mode) for Average detection at frequency above 1GHz.
6. The other emissions is too low to be measured.
7. The data is worse case.



Power	: AC 120V	Pol/Phase	: VERTICAL
Test Mode 1	: 802.11g, CH1	Temperature	: 25 °C
Memo	:	Humidity	: 65 %

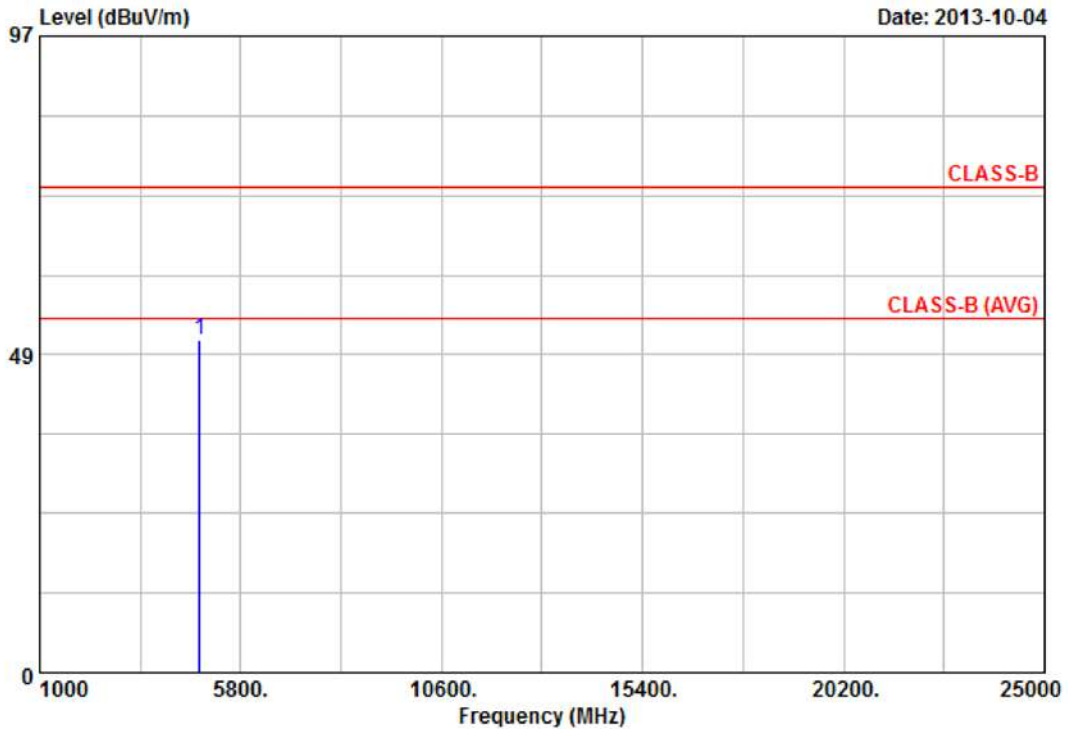

Item	Freq	Read Value	Factor	Result	Limit	Margin	Remark	Ant Pos	Tab Pos
	MHz	dBuV	dB/m	dBuV/m	dBuV/m	dB		cm	Deg
1	4824.69	45.03	5.85	50.88	74.00	-23.12	Peak	100	360

Notes:

1. Result = Read Value + Factor
2. Factor = Antenna Factor + Cable Loss - Amplifier
3. The resolution bandwidth of test receiver/spectrum analyzer is 120KHz and video bandwidth is 300kHz for Peak detection and Quasi-peak detection at frequency below 1GHz.
4. The resolution bandwidth of test receiver/spectrum analyzer is 1MHz and video bandwidth is 3MHz for Peak detection at frequency above 1GHz.
5. The resolution bandwidth of test receiver/spectrum analyzer is 1MHz and video bandwidth is 3MHz (detector sample mode) for Average detection at frequency above 1GHz.
6. The other emissions is too low to be measured.
7. The data is worse case.



Power	: AC 120V	Pol/Phase	: HORIZONTAL
Test Mode 1	: 802.11g, CH1	Temperature	: 25 °C
Memo	:	Humidity	: 65 %

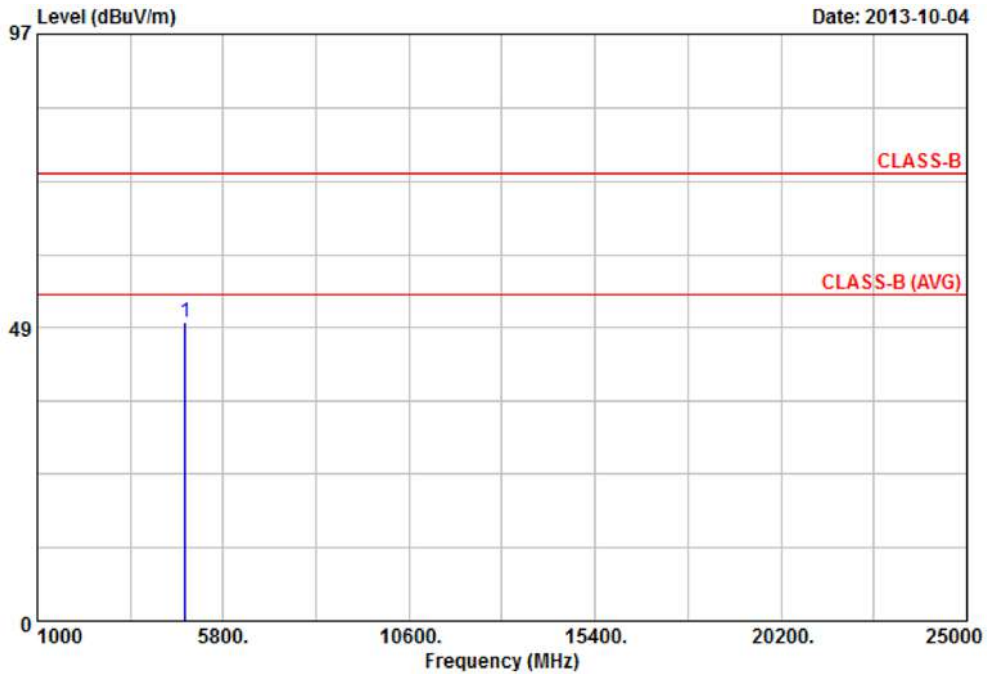

Item	Freq	Read Value	Factor	Result	Limit	Margin	Remark	Ant Pos	Tab Pos
	MHz	dBuV	dB/m	dBuV/m	dBuV/m	dB		cm	Deg
1	4823.94	45.21	4.17	49.38	74.00	-24.62	Peak	100	0

Notes:

1. Result = Read Value + Factor
2. Factor = Antenna Factor + Cable Loss - Amplifier
3. The resolution bandwidth of test receiver/spectrum analyzer is 120KHz and video bandwidth is 300kHz for Peak detection and Quasi-peak detection at frequency below 1GHz.
4. The resolution bandwidth of test receiver/spectrum analyzer is 1MHz and video bandwidth is 3MHz for Peak detection at frequency above 1GHz.
5. The resolution bandwidth of test receiver/spectrum analyzer is 1MHz and video bandwidth is 3MHz (detector sample mode) for Average detection at frequency above 1GHz.
6. The other emissions is too low to be measured.
7. The data is worse case.





Power	: AC 120V	Pol/Phase	: VERTICAL
Test Mode 1	: 802.11g, CH6	Temperature	: 25 °C
Memo	:	Humidity	: 65 %

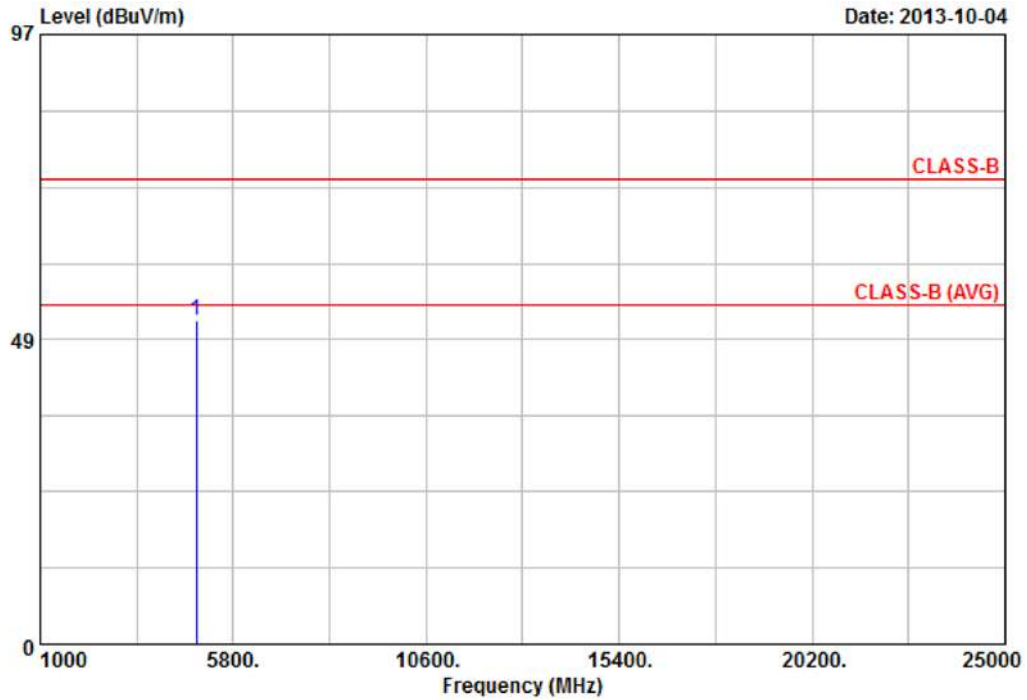

Item	Freq	Read Value	Factor	Result	Limit	Margin	Remark	Ant Pos	Tab Pos
	MHz	dBuV	dB/m	dBuV/m	dBuV/m	dB		cm	Deg
1	4874.77	44.77	6.84	51.61	74.00	-22.39	Peak	100	360

Notes:

1. Result = Read Value + Factor
2. Factor = Antenna Factor + Cable Loss - Amplifier
3. The resolution bandwidth of test receiver/spectrum analyzer is 120KHz and video bandwidth is 300kHz for Peak detection and Quasi-peak detection at frequency below 1GHz.
4. The resolution bandwidth of test receiver/spectrum analyzer is 1MHz and video bandwidth is 3MHz for Peak detection at frequency above 1GHz.
5. The resolution bandwidth of test receiver/spectrum analyzer is 1MHz and video bandwidth is 3MHz (detector sample mode) for Average detection at frequency above 1GHz.
6. The other emissions is too low to be measured.
7. The data is worse case.



Power	: AC 120V	Pol/Phase	: HORIZONTAL
Test Mode 1	: 802.11g, CH6	Temperature	: 25 °C
Memo	:	Humidity	: 65 %

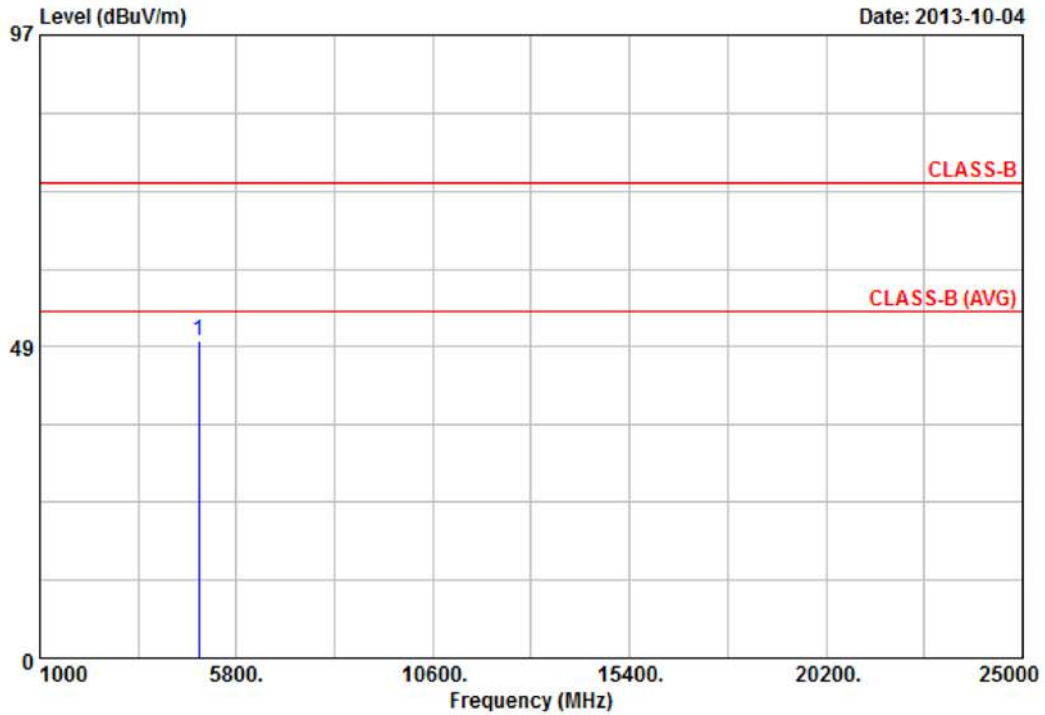

Item	Freq	Read Value	Factor	Result	Limit	Margin	Remark	Ant Pos	Tab Pos
	MHz	dBuV	dB/m	dBuV/m	dBuV/m	dB		cm	Deg
1	4874.75	44.48	4.98	49.46	74.00	-24.54	Peak	100	0

Notes:

1. Result = Read Value + Factor
2. Factor = Antenna Factor + Cable Loss - Amplifier
3. The resolution bandwidth of test receiver/spectrum analyzer is 120KHz and video bandwidth is 300kHz for Peak detection and Quasi-peak detection at frequency below 1GHz.
4. The resolution bandwidth of test receiver/spectrum analyzer is 1MHz and video bandwidth is 3MHz for Peak detection at frequency above 1GHz.
5. The resolution bandwidth of test receiver/spectrum analyzer is 1MHz and video bandwidth is 3MHz (detector sample mode) for Average detection at frequency above 1GHz.
6. The other emissions is too low to be measured.
7. The data is worse case.



Power	: AC 120V	Pol/Phase	: VERTICAL
Test Mode 1	: 802.11g, CH11	Temperature	: 25 °C
Memo	:	Humidity	: 65 %

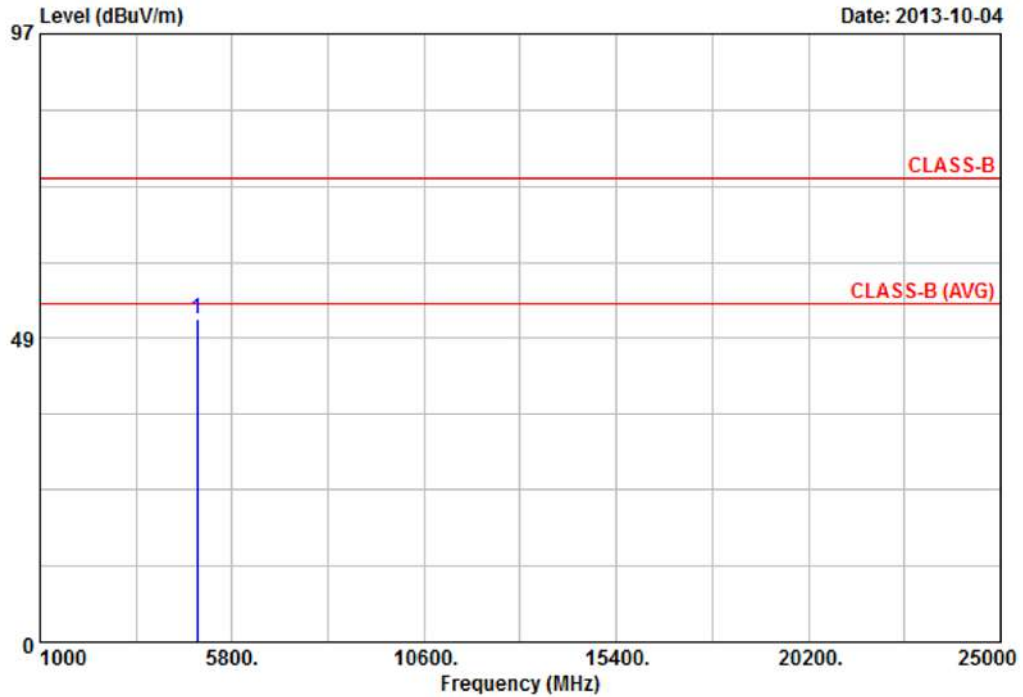

Item	Freq	Read Value	Factor	Result	Limit	Margin	Remark	Ant Pos	Tab Pos
	MHz	dBuV	dB/m	dBuV/m	dBuV/m	dB		cm	Deg
1	4924.94	44.30	7.40	51.70	74.00	-22.30	Peak	100	360

Notes:

1. Result = Read Value + Factor
2. Factor = Antenna Factor + Cable Loss - Amplifier
3. The resolution bandwidth of test receiver/spectrum analyzer is 120KHz and video bandwidth is 300kHz for Peak detection and Quasi-peak detection at frequency below 1GHz.
4. The resolution bandwidth of test receiver/spectrum analyzer is 1MHz and video bandwidth is 3MHz for Peak detection at frequency above 1GHz.
5. The resolution bandwidth of test receiver/spectrum analyzer is 1MHz and video bandwidth is 3MHz (detector sample mode) for Average detection at frequency above 1GHz.
6. The other emissions is too low to be measured.
7. The data is worse case.



Power	: AC 120V	Pol/Phase	: HORIZONTAL
Test Mode 1	: 802.11g, CH11	Temperature	: 25 °C
Memo	:	Humidity	: 65 %

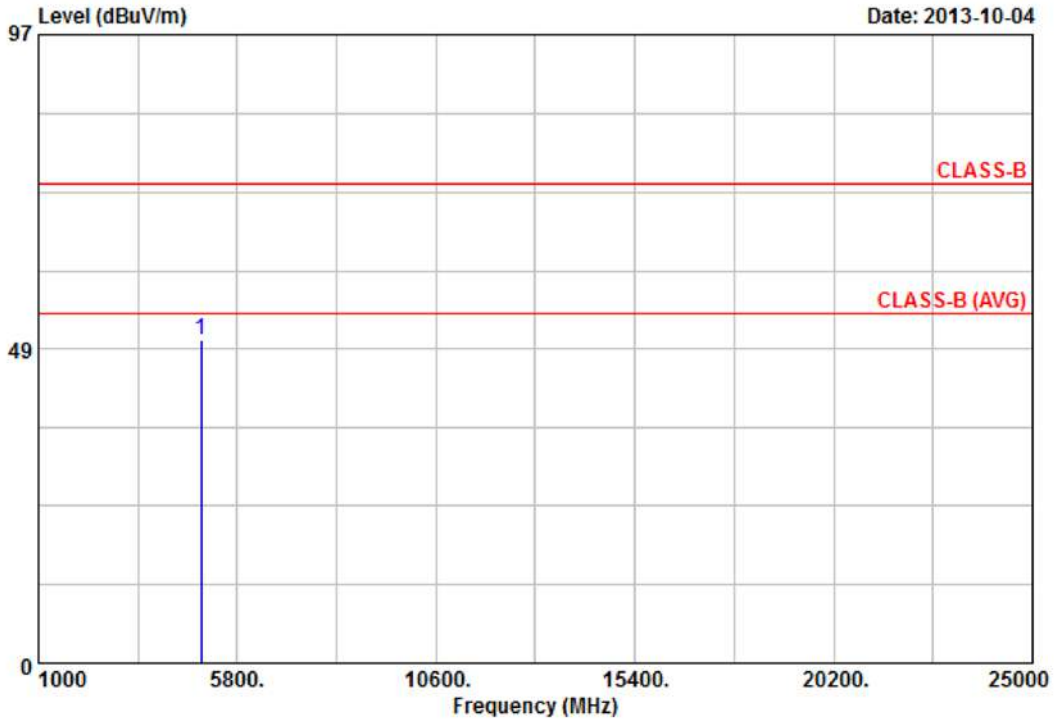

Item	Freq	Read Value	Factor	Result	Limit	Margin	Remark	Ant Pos	Tab Pos
	MHz	dBuV	dB/m	dBuV/m	dBuV/m	dB		cm	Deg
1	4923.93	44.69	5.39	50.08	74.00	-23.92	Peak	100	0

Notes:

1. Result = Read Value + Factor
2. Factor = Antenna Factor + Cable Loss - Amplifier
3. The resolution bandwidth of test receiver/spectrum analyzer is 120KHz and video bandwidth is 300kHz for Peak detection and Quasi-peak detection at frequency below 1GHz.
4. The resolution bandwidth of test receiver/spectrum analyzer is 1MHz and video bandwidth is 3MHz for Peak detection at frequency above 1GHz.
5. The resolution bandwidth of test receiver/spectrum analyzer is 1MHz and video bandwidth is 3MHz (detector sample mode) for Average detection at frequency above 1GHz.
6. The other emissions is too low to be measured.
7. The data is worse case.



Power	: AC 120V	Pol/Phase	: VERTICAL
Test Mode 2	: 802.11n HT20, CH1	Temperature	: 25 °C
Memo	:	Humidity	: 65 %

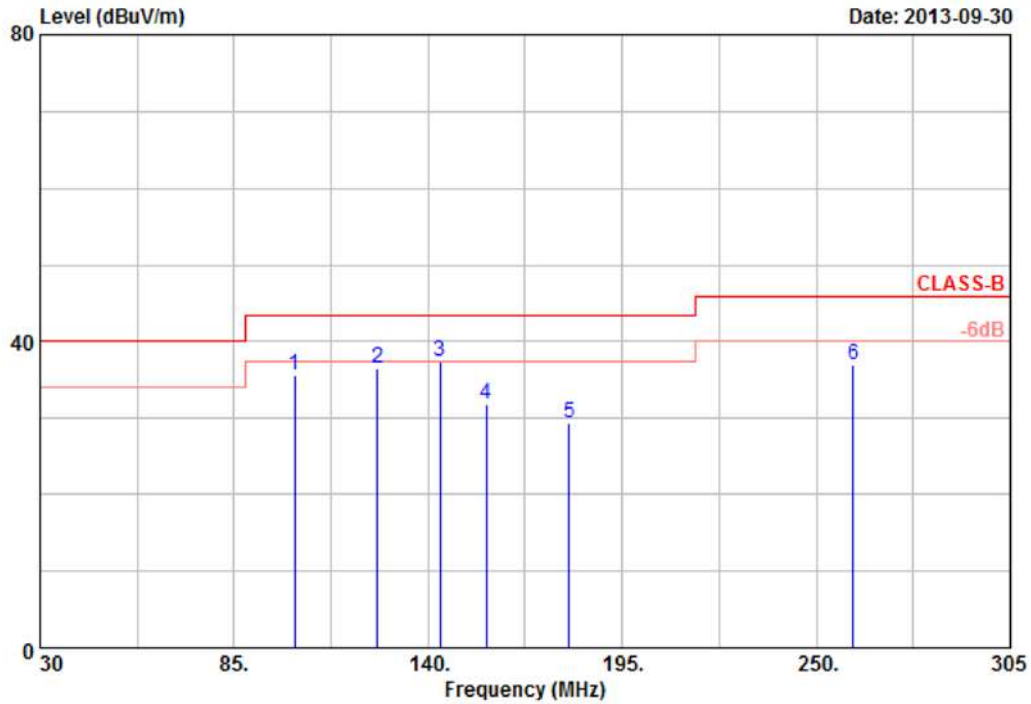

Item	Freq	Read Value	Factor	Result	Limit	Margin	Remark	Ant Pos	Tab Pos
	MHz	dBuV	dB/m	dBuV/m	dBuV/m	dB		cm	Deg
1	102.05	44.12	-8.39	35.73	43.50	-7.77	Peak	100	360
2	125.70	41.93	-5.38	36.55	43.50	-6.95	Peak	100	360
3	143.30	46.03	-8.50	37.53	43.50	-5.97	QP	100	360
4	156.50	44.25	-12.27	31.98	43.50	-11.52	Peak	100	360
5	179.88	34.44	-5.06	29.38	43.50	-14.12	Peak	100	360
6	260.45	44.75	-7.72	37.03	46.00	-8.97	Peak	100	360

Notes:

1. Result = Read Value + Factor
2. Factor = Antenna Factor + Cable Loss - Amplifier
3. The resolution bandwidth of test receiver/spectrum analyzer is 120KHz and video bandwidth is 300kHz for Peak detection and Quasi-peak detection at frequency below 1GHz.
4. All below 1GHz configurations are pretested among available 802.11b/g/n modes and found that the worst cases are on channel 1 of 802.11g & n20 mode and Channel 3 for n40 mode. Only worst case data concluded above were presented in this test report.
5. The data is worse case.





Power	: AC 120V	Pol/Phase	: VERTICAL
Test Mode 2	: 802.11n HT20, CH1	Temperature	: 25 °C
Memo	:	Humidity	: 65 %

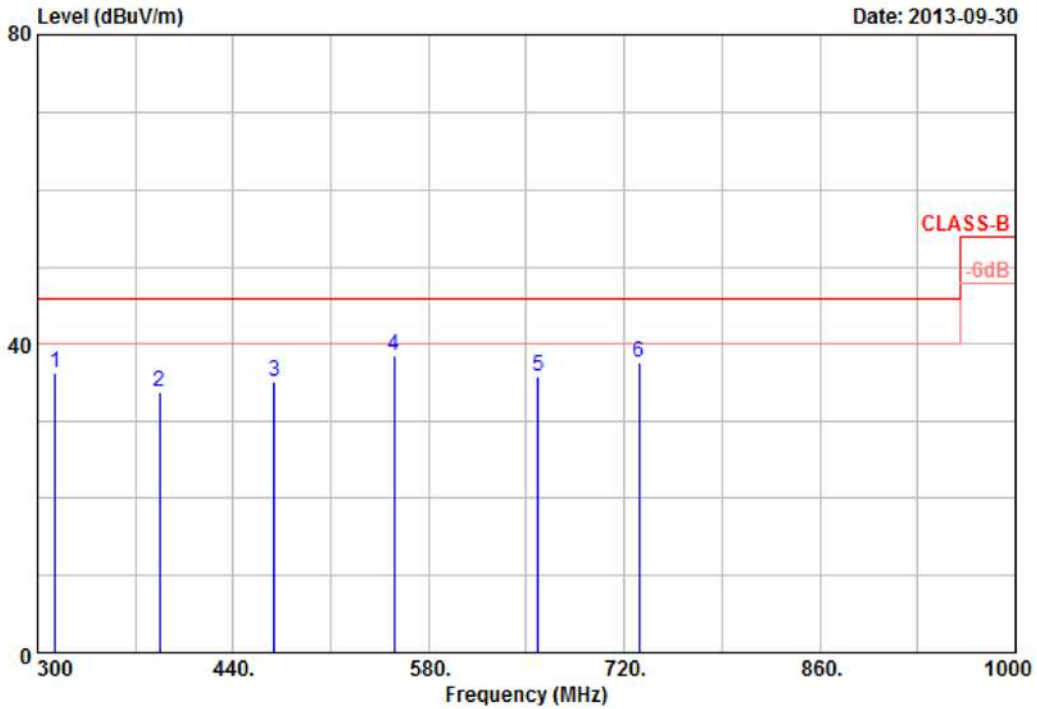

Item	Freq MHz	Read Value dBuV	Factor dB/m	Result dBuV/m	Limit dBuV/m	Margin dB	Remark	Ant Pos cm	Tab Pos Deg
1	312.60	46.10	-9.75	36.35	46.00	-9.65	Peak	100	0
2	387.50	40.78	-6.98	33.80	46.00	-12.20	Peak	100	0
3	469.40	42.46	-7.35	35.11	46.00	-10.89	Peak	100	0
4	555.50	30.94	7.64	38.58	46.00	-7.42	Peak	100	0
5	658.40	36.80	-1.01	35.79	46.00	-10.21	Peak	100	0
6	730.50	30.40	7.18	37.58	46.00	-8.42	Peak	100	0

Notes:

1. Result = Read Value + Factor
2. Factor = Antenna Factor + Cable Loss - Amplifier
3. The resolution bandwidth of test receiver/spectrum analyzer is 120KHz and video bandwidth is 300kHz for Peak detection and Quasi-peak detection at frequency below 1GHz.
4. All below 1GHz configurations are pretested among available 802.11b/g/n modes and found that the worst cases are on channel 1 of 802.11g & n20 mode and Channel 3 for n40 mode. Only worst case data concluded above were presented in this test report.
5. The data is worse case.



Power	: AC 120V	Pol/Phase	: HORIZONTAL
Test Mode 2	: 802.11n HT20, CH1	Temperature	: 25 °C
Memo	:	Humidity	: 65 %

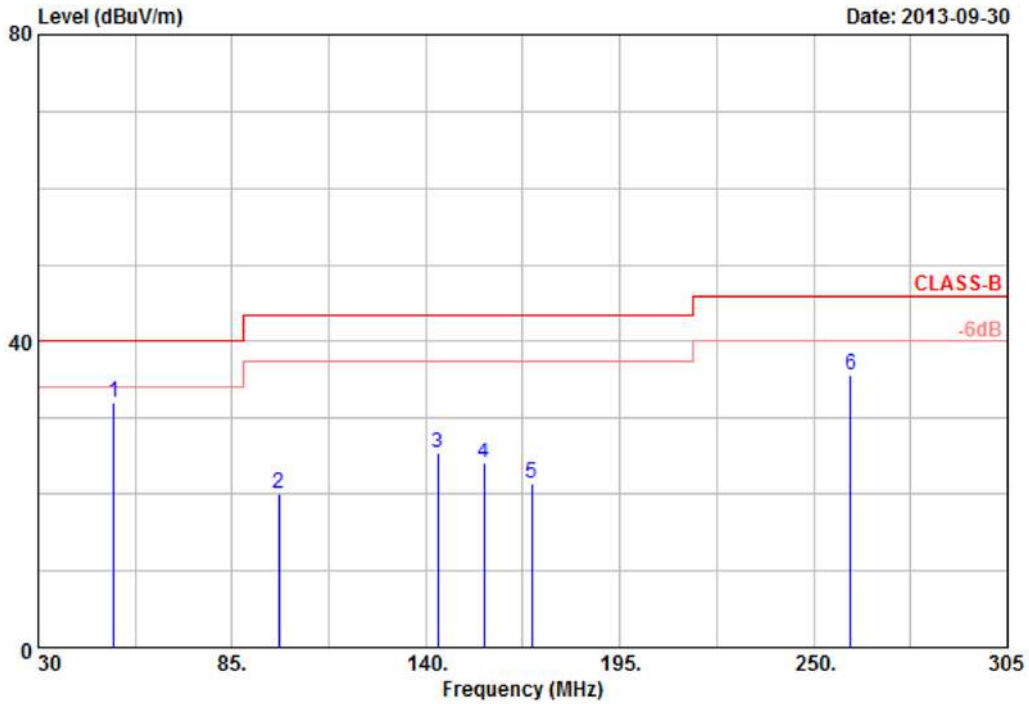

Item	Freq	Read Value	Factor	Result	Limit	Margin	Remark	Ant Pos	Tab Pos
	MHz	dBuV	dB/m	dBuV/m	dBuV/m	dB		cm	Deg
1	51.45	41.80	-9.82	31.98	40.00	-8.02	Peak	100	360
2	98.20	38.72	-18.63	20.09	43.50	-23.41	Peak	100	360
3	143.30	40.01	-14.65	25.36	43.50	-18.14	Peak	100	360
4	156.50	40.21	-16.14	24.07	43.50	-19.43	Peak	100	360
5	169.98	32.38	-10.97	21.41	43.50	-22.09	Peak	100	360
6	260.45	49.04	-13.30	35.74	46.00	-10.26	Peak	100	360

Notes:

1. Result = Read Value + Factor
2. Factor = Antenna Factor + Cable Loss - Amplifier
3. The resolution bandwidth of test receiver/spectrum analyzer is 120KHz and video bandwidth is 300kHz for Peak detection and Quasi-peak detection at frequency below 1GHz.
4. All below 1GHz configurations are pretested among available 802.11b/g/n modes and found that the worst cases are on channel 1 of 802.11g & n20 mode and Channel 3 for n40 mode. Only worst case data concluded above were presented in this test report.
5. The data is worse case.



Power	: AC 120V	Pol/Phase	: HORIZONTAL
Test Mode 2	: 802.11n HT20, CH1	Temperature	: 25 °C
Memo	:	Humidity	: 65 %

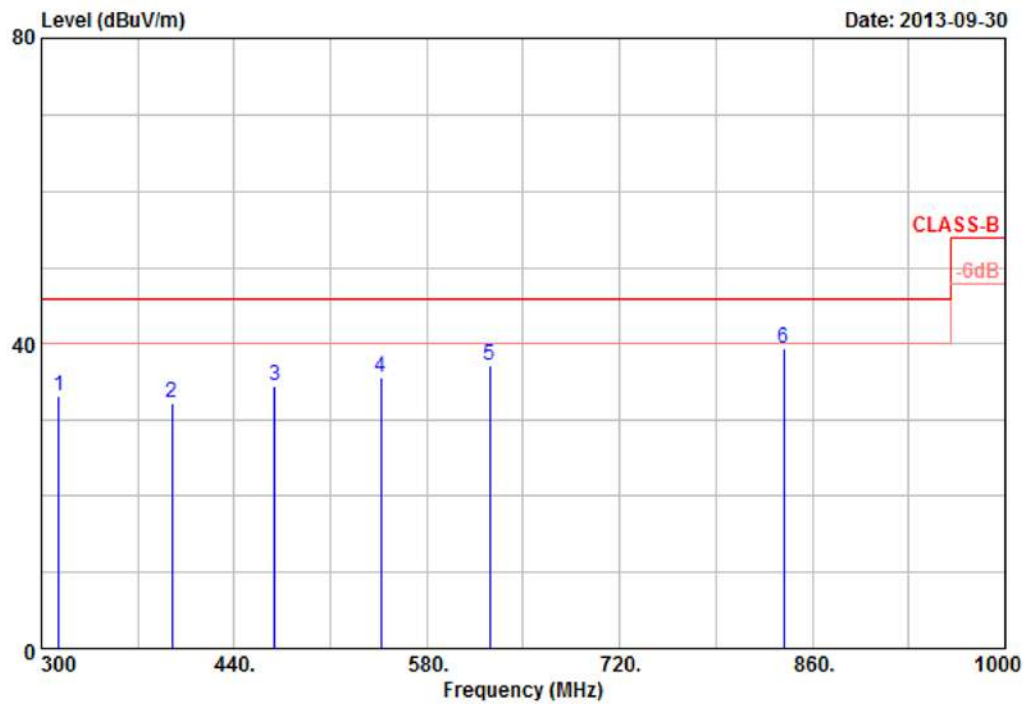

Item	Freq	Read Value	Factor	Result	Limit	Margin	Remark	Ant Pos	Tab Pos
	MHz	dBuV	dB/m	dBuV/m	dBuV/m	dB		cm	Deg
1	312.60	45.75	-12.58	33.17	46.00	-12.83	Peak	100	0
2	394.50	42.39	-10.14	32.25	46.00	-13.75	Peak	100	0
3	469.40	39.80	-5.27	34.53	46.00	-11.47	Peak	100	0
4	546.40	32.67	2.88	35.55	46.00	-10.45	Peak	100	0
5	625.50	32.92	4.23	37.15	46.00	-8.85	Peak	100	0
6	839.00	30.88	8.66	39.54	46.00	-6.46	Peak	100	0

Notes:

1. Result = Read Value + Factor
2. Factor = Antenna Factor + Cable Loss - Amplifier
3. The resolution bandwidth of test receiver/spectrum analyzer is 120KHz and video bandwidth is 300kHz for Peak detection and Quasi-peak detection at frequency below 1GHz.
4. All below 1GHz configurations are pretested among available 802.11b/g/n modes and found that the worst cases are on channel 1 of 802.11g & n20 mode and Channel 3 for n40 mode. Only worst case data concluded above were presented in this test report.
5. The data is worse case.





Power	: AC 120V	Pol/Phase	: VERTICAL
Test Mode 2	: 802.11n HT20, CH1	Temperature	: 25 °C
Memo	:	Humidity	: 65 %

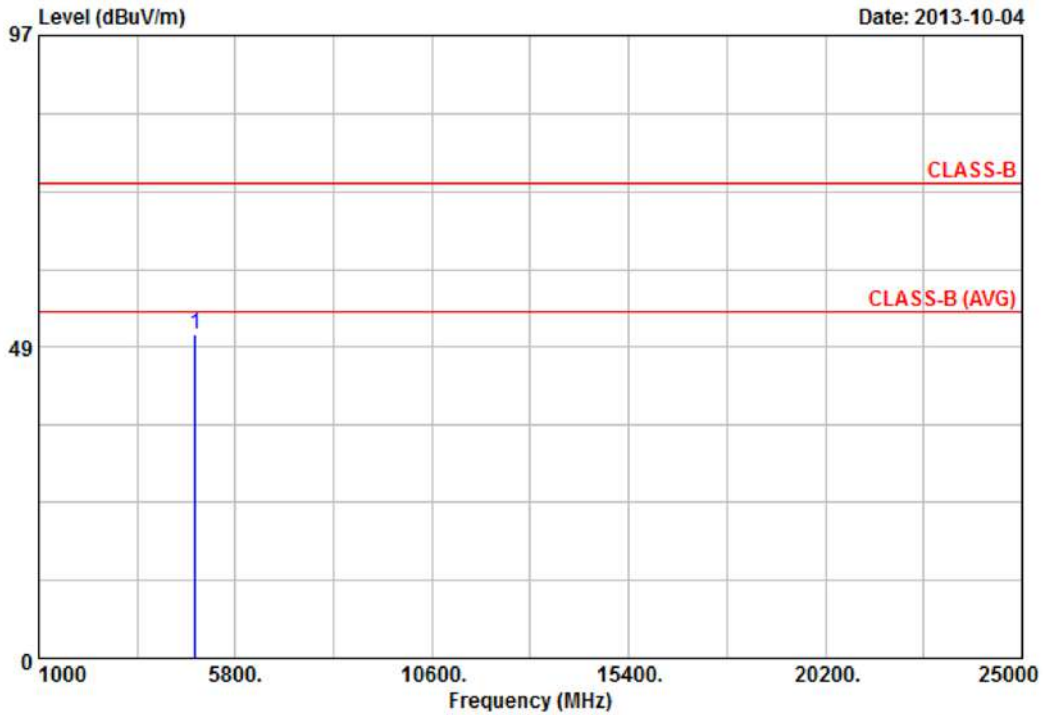

Item	Freq	Read Value	Factor	Result	Limit	Margin	Remark	Ant Pos	Tab Pos
	MHz	dBuV	dB/m	dBuV/m	dBuV/m	dB		cm	Deg
1	4824.89	44.59	5.85	50.44	74.00	-23.56	Peak	100	360

Notes:

1. Result = Read Value + Factor
2. Factor = Antenna Factor + Cable Loss - Amplifier
3. The resolution bandwidth of test receiver/spectrum analyzer is 120KHz and video bandwidth is 300kHz for Peak detection and Quasi-peak detection at frequency below 1GHz.
4. The resolution bandwidth of test receiver/spectrum analyzer is 1MHz and video bandwidth is 3MHz for Peak detection at frequency above 1GHz.
5. The resolution bandwidth of test receiver/spectrum analyzer is 1MHz and video bandwidth is 3MHz (detector sample mode) for Average detection at frequency above 1GHz.
6. The other emissions is too low to be measured.
7. The data is worse case.



Power	: AC 120V	Pol/Phase	: HORIZONTAL
Test Mode 2	: 802.11n HT20, CH1	Temperature	: 25 °C
Memo	:	Humidity	: 65 %

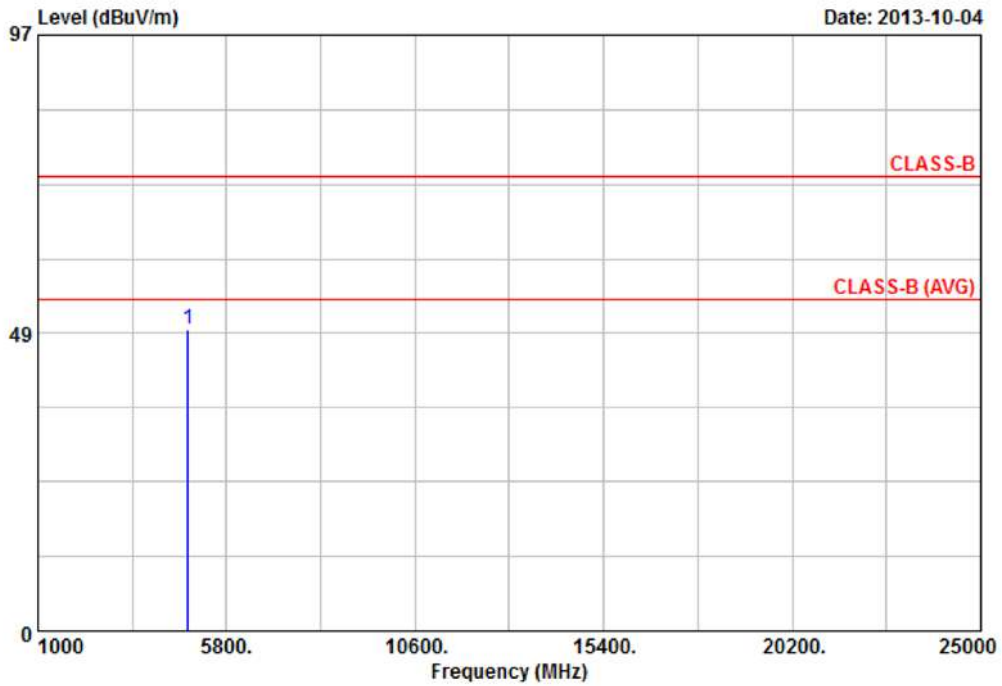

Item	Freq	Read Value	Factor	Result	Limit	Margin	Remark	Ant Pos	Tab Pos
	MHz	dBuV	dB/m	dBuV/m	dBuV/m	dB		cm	Deg
1	4824.50	45.12	4.18	49.30	74.00	-24.70	Peak	100	0

Notes:

1. Result = Read Value + Factor
2. Factor = Antenna Factor + Cable Loss - Amplifier
3. The resolution bandwidth of test receiver/spectrum analyzer is 120KHz and video bandwidth is 300kHz for Peak detection and Quasi-peak detection at frequency below 1GHz.
4. The resolution bandwidth of test receiver/spectrum analyzer is 1MHz and video bandwidth is 3MHz for Peak detection at frequency above 1GHz.
5. The resolution bandwidth of test receiver/spectrum analyzer is 1MHz and video bandwidth is 3MHz (detector sample mode) for Average detection at frequency above 1GHz.
6. The other emissions is too low to be measured.
7. The data is worse case.



Power	: AC 120V	Pol/Phase	: VERTICAL
Test Mode 2	: 802.11n HT20, CH6	Temperature	: 25 °C
Memo	:	Humidity	: 65 %

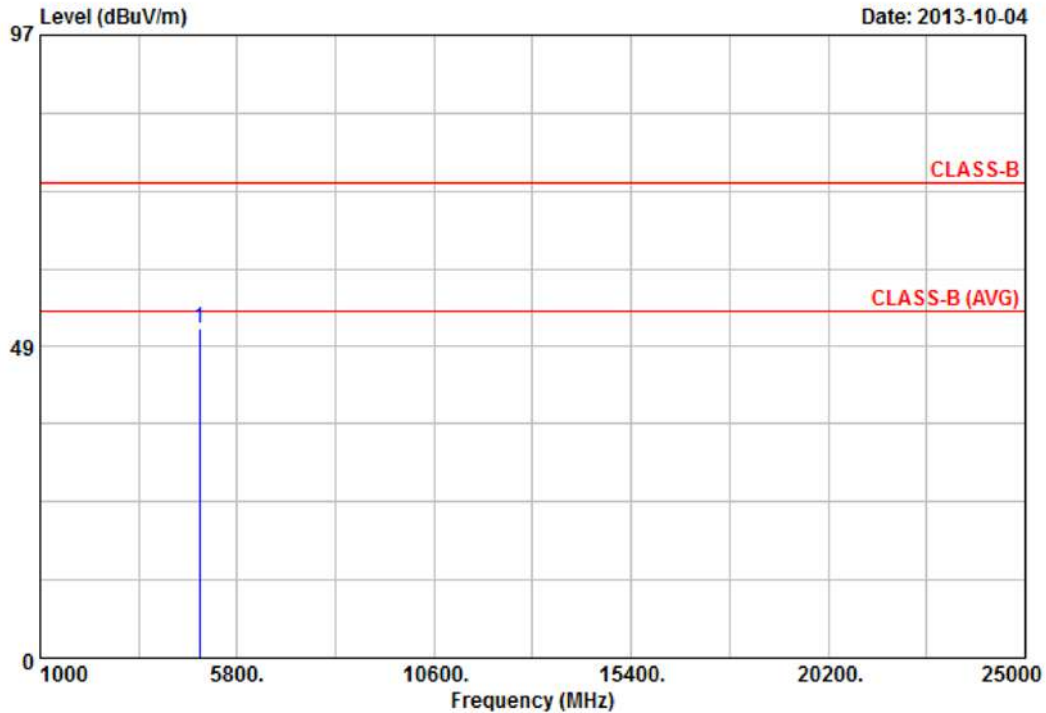

Item	Freq	Read Value	Factor	Result	Limit	Margin	Remark	Ant Pos	Tab Pos
	MHz	dBuV	dB/m	dBuV/m	dBuV/m	dB		cm	Deg
1	4875.00	44.57	6.84	51.41	74.00	-22.59	Peak	100	360

Notes:

1. Result = Read Value + Factor
2. Factor = Antenna Factor + Cable Loss - Amplifier
3. The resolution bandwidth of test receiver/spectrum analyzer is 120KHz and video bandwidth is 300kHz for Peak detection and Quasi-peak detection at frequency below 1GHz.
4. The resolution bandwidth of test receiver/spectrum analyzer is 1MHz and video bandwidth is 3MHz for Peak detection at frequency above 1GHz.
5. The resolution bandwidth of test receiver/spectrum analyzer is 1MHz and video bandwidth is 3MHz (detector sample mode) for Average detection at frequency above 1GHz.
6. The other emissions is too low to be measured.
7. The data is worse case.



Power	: AC 120V	Pol/Phase	: HORIZONTAL
Test Mode 2	: 802.11n HT20, CH6	Temperature	: 25 °C
Memo	:	Humidity	: 65 %

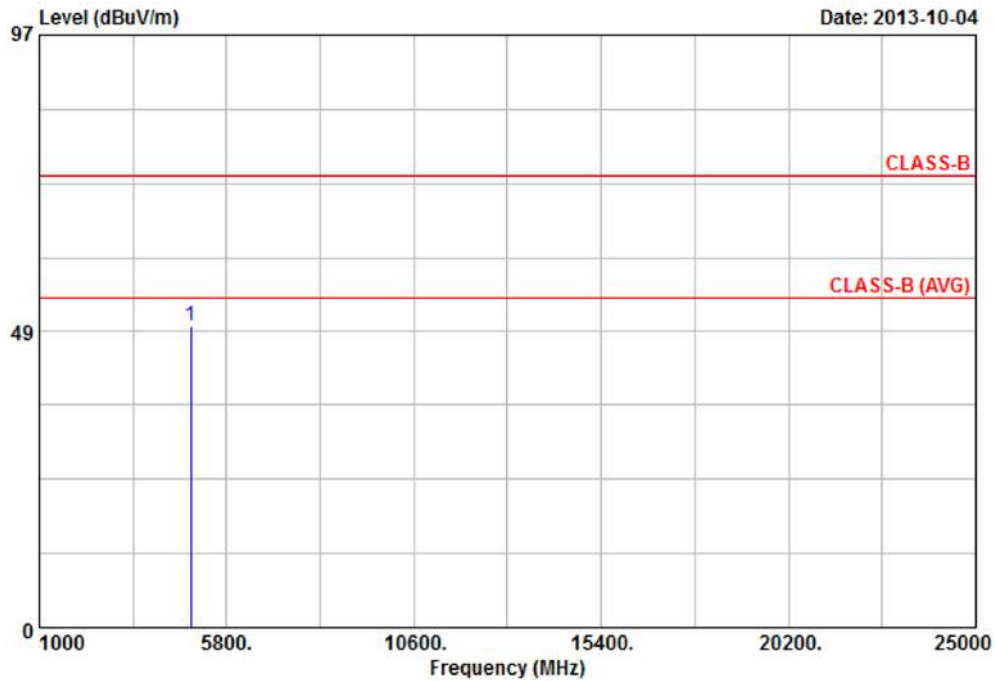

Item	Freq	Read Value	Factor	Result	Limit	Margin	Remark	Ant Pos	Tab Pos
	MHz	dBuV	dB/m	dBuV/m	dBuV/m	dB		cm	Deg
1	4873.93	44.38	4.97	49.35	74.00	-24.65	Peak	101	0

Notes:

1. Result = Read Value + Factor
2. Factor = Antenna Factor + Cable Loss - Amplifier
3. The resolution bandwidth of test receiver/spectrum analyzer is 120KHz and video bandwidth is 300kHz for Peak detection and Quasi-peak detection at frequency below 1GHz.
4. The resolution bandwidth of test receiver/spectrum analyzer is 1MHz and video bandwidth is 3MHz for Peak detection at frequency above 1GHz.
5. The resolution bandwidth of test receiver/spectrum analyzer is 1MHz and video bandwidth is 3MHz (detector sample mode) for Average detection at frequency above 1GHz.
6. The other emissions is too low to be measured.
7. The data is worse case.



Power	: AC 120V	Pol/Phase	: VERTICAL
Test Mode 2	: 802.11n HT20, CH11	Temperature	: 25 °C
Memo	:	Humidity	: 65 %

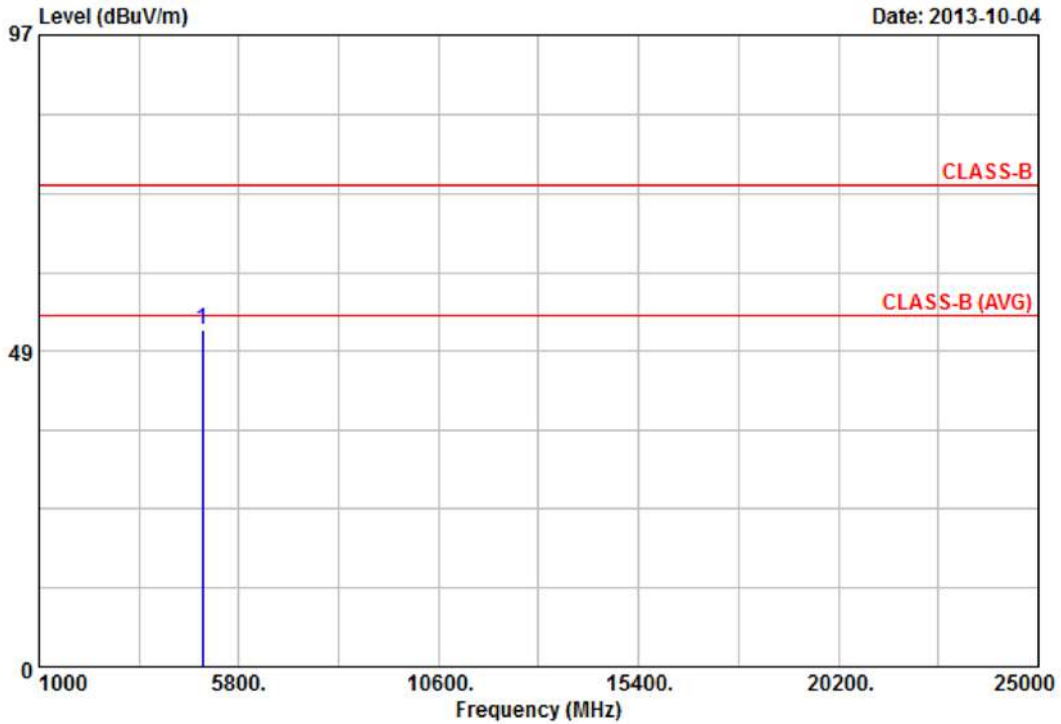

Item	Freq	Read Value	Factor	Result	Limit	Margin	Remark	Ant Pos	Tab Pos
	MHz	dBuV	dB/m	dBuV/m	dBuV/m	dB		cm	Deg
1	4924.16	44.35	7.40	51.75	74.00	-22.25	Peak	101	360

Notes:

1. Result = Read Value + Factor
2. Factor = Antenna Factor + Cable Loss - Amplifier
3. The resolution bandwidth of test receiver/spectrum analyzer is 120KHz and video bandwidth is 300kHz for Peak detection and Quasi-peak detection at frequency below 1GHz.
4. The resolution bandwidth of test receiver/spectrum analyzer is 1MHz and video bandwidth is 3MHz for Peak detection at frequency above 1GHz.
5. The resolution bandwidth of test receiver/spectrum analyzer is 1MHz and video bandwidth is 3MHz (detector sample mode) for Average detection at frequency above 1GHz.
6. The other emissions is too low to be measured.
7. The data is worse case.





Power	: AC 120V	Pol/Phase	: HORIZONTAL
Test Mode 2	: 802.11n HT20, CH11	Temperature	: 25 °C
Memo	:	Humidity	: 65 %

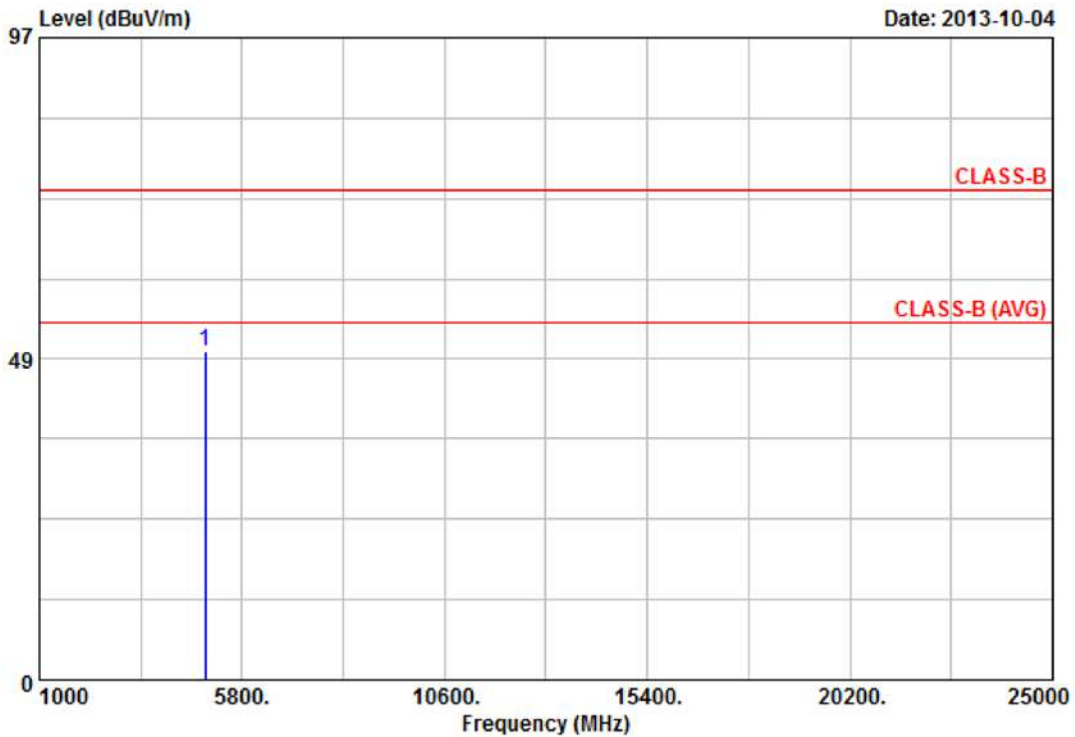

Item	Freq	Read Value	Factor	Result	Limit	Margin	Remark	Ant Pos	Tab Pos
	MHz	dBuV	dB/m	dBuV/m	dBuV/m	dB		cm	Deg
1	4924.13	44.21	5.39	49.60	74.00	-24.40	Peak	101	0

Notes:

1. Result = Read Value + Factor
2. Factor = Antenna Factor + Cable Loss - Amplifier
3. The resolution bandwidth of test receiver/spectrum analyzer is 120KHz and video bandwidth is 300kHz for Peak detection and Quasi-peak detection at frequency below 1GHz.
4. The resolution bandwidth of test receiver/spectrum analyzer is 1MHz and video bandwidth is 3MHz for Peak detection at frequency above 1GHz.
5. The resolution bandwidth of test receiver/spectrum analyzer is 1MHz and video bandwidth is 3MHz (detector sample mode) for Average detection at frequency above 1GHz.
6. The other emissions is too low to be measured.
7. The data is worse case.



Power	: AC 120V	Pol/Phase	: VERTICAL
Test Mode 3	: 802.11n HT40, CH3	Temperature	: 25 °C
Memo	:	Humidity	: 65 %

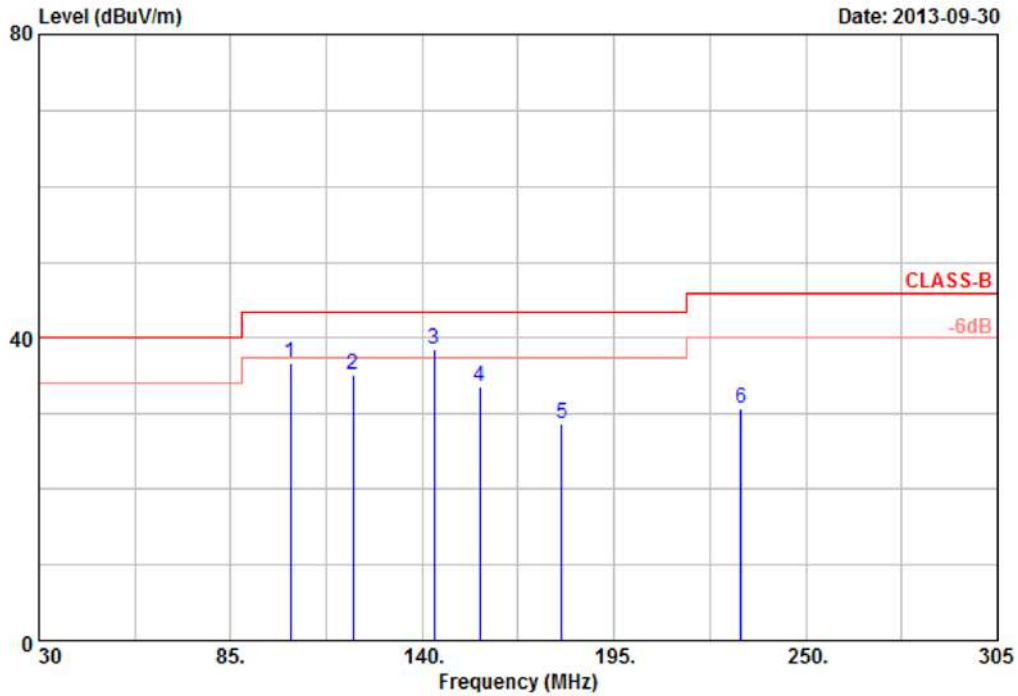

Item	Freq	Read Value	Factor	Result	Limit	Margin	Remark	Ant Pos	Tab Pos
	MHz	dBuV	dB/m	dBuV/m	dBuV/m	dB		cm	Deg
1	102.05	45.09	-8.39	36.70	43.50	-6.80	Peak	100	360
2	120.20	39.80	-4.66	35.14	43.50	-8.36	Peak	100	360
3	143.30	46.96	-8.50	38.46	43.50	-5.04	QP	100	360
4	156.50	45.98	-12.27	33.71	43.50	-9.79	Peak	100	360
5	179.88	33.86	-5.06	28.80	43.50	-14.70	Peak	100	360
6	231.30	38.59	-7.84	30.75	46.00	-15.25	Peak	100	360

Notes:

1. Result = Read Value + Factor
2. Factor = Antenna Factor + Cable Loss - Amplifier
3. The resolution bandwidth of test receiver/spectrum analyzer is 120KHz and video bandwidth is 300kHz for Peak detection and Quasi-peak detection at frequency below 1GHz.
4. All below 1GHz configurations are pretested among available 802.11b/g/n modes and found that the worst cases are on channel 1 of 802.11g & n20 mode and Channel 3 for n40 mode. Only worst case data concluded above were presented in this test report.
5. The data is worse case.



Power	: AC 120V	Pol/Phase	: VERTICAL
Test Mode 3	: 802.11n HT40, CH3	Temperature	: 25 °C
Memo	:	Humidity	: 65 %

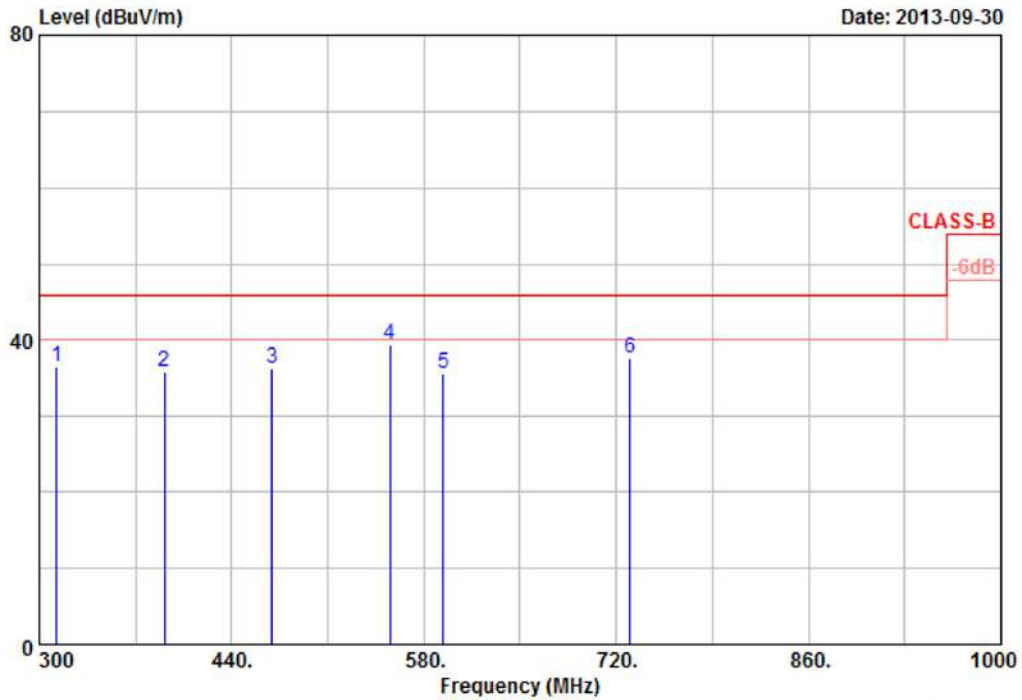

Item	Freq	Read Value	Factor	Result	Limit	Margin	Remark	Ant Pos	Tab Pos
	MHz	dBuV	dB/m	dBuV/m	dBuV/m	dB		cm	Deg
1	312.60	46.29	-9.75	36.54	46.00	-9.46	Peak	100	0
2	391.00	42.09	-6.30	35.79	46.00	-10.21	Peak	100	0
3	469.40	43.78	-7.35	36.43	46.00	-9.57	Peak	100	0
4	555.50	31.69	7.64	39.33	46.00	-6.67	Peak	100	0
5	594.00	31.96	3.62	35.58	46.00	-10.42	Peak	100	0
6	729.80	30.44	7.17	37.61	46.00	-8.39	Peak	100	0

Notes:

1. Result = Read Value + Factor
2. Factor = Antenna Factor + Cable Loss - Amplifier
3. The resolution bandwidth of test receiver/spectrum analyzer is 120KHz and video bandwidth is 300kHz for Peak detection and Quasi-peak detection at frequency below 1GHz.
4. All below 1GHz configurations are pretested among available 802.11b/g/n modes and found that the worst cases are on channel 1 of 802.11g & n20 mode and Channel 3 for n40 mode. Only worst case data concluded above were presented in this test report.
5. The data is worse case.





Power	: AC 120V	Pol/Phase	: HORIZONTAL
Test Mode 3	: 802.11n HT40, CH3	Temperature	: 25 °C
Memo	:	Humidity	: 65 %

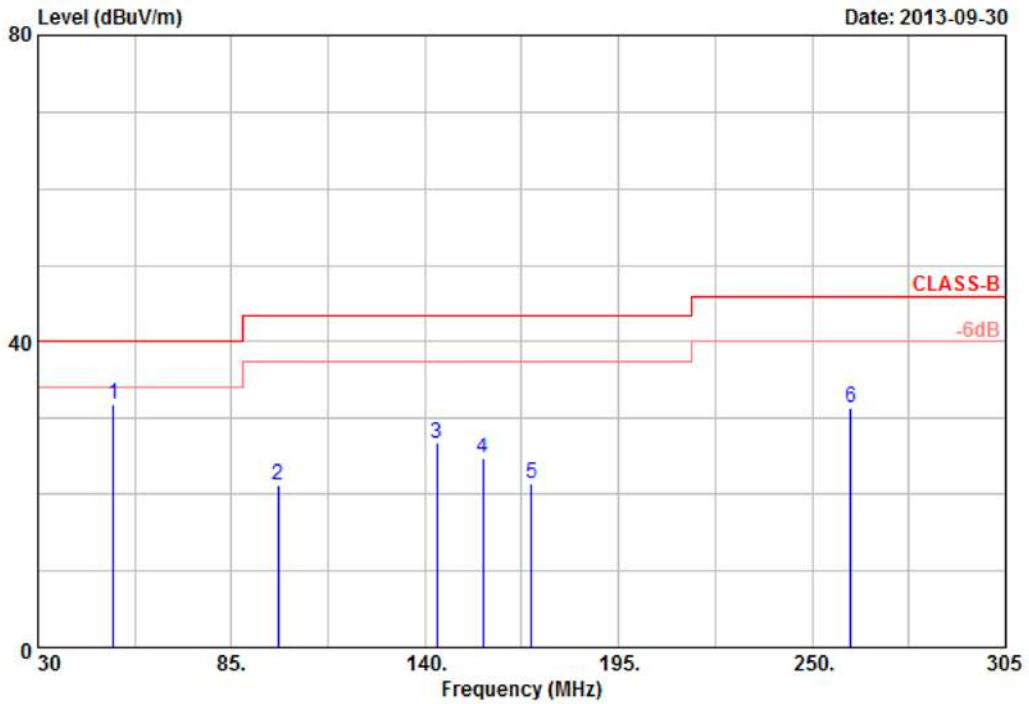

Item	Freq	Read Value	Factor	Result	Limit	Margin	Remark	Ant Pos	Tab Pos
	MHz	dBuV	dB/m	dBuV/m	dBuV/m	dB		cm	Deg
1	51.45	41.61	-9.82	31.79	40.00	-8.21	Peak	100	360
2	98.20	39.74	-18.63	21.11	43.50	-22.39	Peak	100	360
3	143.30	41.31	-14.65	26.66	43.50	-16.84	Peak	100	360
4	156.50	40.90	-16.14	24.76	43.50	-18.74	Peak	100	360
5	170.25	32.60	-11.29	21.31	43.50	-22.19	Peak	100	360
6	261.00	44.71	-13.37	31.34	46.00	-14.66	Peak	100	360

Notes:

1. Result = Read Value + Factor
2. Factor = Antenna Factor + Cable Loss - Amplifier
3. The resolution bandwidth of test receiver/spectrum analyzer is 120KHz and video bandwidth is 300kHz for Peak detection and Quasi-peak detection at frequency below 1GHz.
4. All below 1GHz configurations are pretested among available 802.11b/g/n modes and found that the worst cases are on channel 1 of 802.11g & n20 mode and Channel 3 for n40 mode. Only worst case data concluded above were presented in this test report.
5. The data is worse case.



Power	: AC 120V	Pol/Phase	: HORIZONTAL
Test Mode 3	: 802.11n HT40, CH3	Temperature	: 25 °C
Memo	:	Humidity	: 65 %

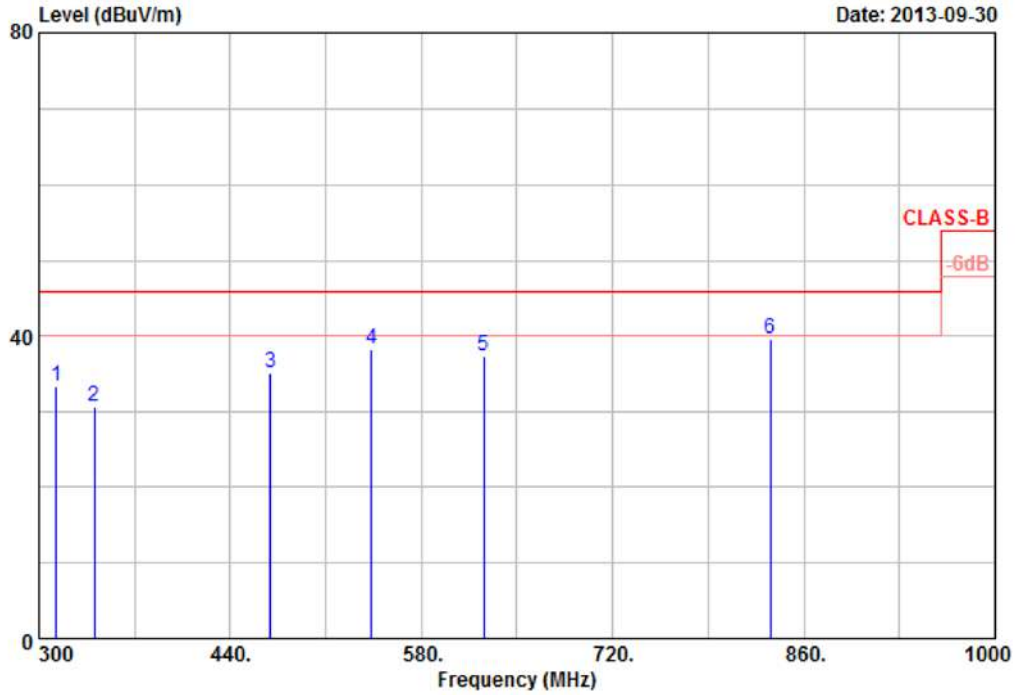

Item	Freq	Read Value	Factor	Result	Limit	Margin	Remark	Ant Pos	Tab Pos
	MHz	dBuV	dB/m	dBuV/m	dBuV/m	dB		cm	Deg
1	312.60	46.03	-12.58	33.45	46.00	-12.55	Peak	100	0
2	340.60	39.70	-8.96	30.74	46.00	-15.26	Peak	100	0
3	469.40	40.48	-5.27	35.21	46.00	-10.79	Peak	100	0
4	543.60	35.82	2.51	38.33	46.00	-7.67	Peak	100	0
5	625.50	33.11	4.23	37.34	46.00	-8.66	Peak	100	0
6	835.50	30.74	8.89	39.63	46.00	-6.37	Peak	100	0

Notes:

1. Result = Read Value + Factor
2. Factor = Antenna Factor + Cable Loss - Amplifier
3. The resolution bandwidth of test receiver/spectrum analyzer is 120KHz and video bandwidth is 300kHz for Peak detection and Quasi-peak detection at frequency below 1GHz.
4. All below 1GHz configurations are pretested among available 802.11b/g/n modes and found that the worst cases are on channel 1 of 802.11g & n20 mode and Channel 3 for n40 mode. Only worst case data concluded above were presented in this test report.
5. The data is worse case.



Power	: AC 120V	Pol/Phase	: VERTICAL
Test Mode 3	: 802.11n HT40, CH3	Temperature	: 25 °C
Memo	:	Humidity	: 65 %

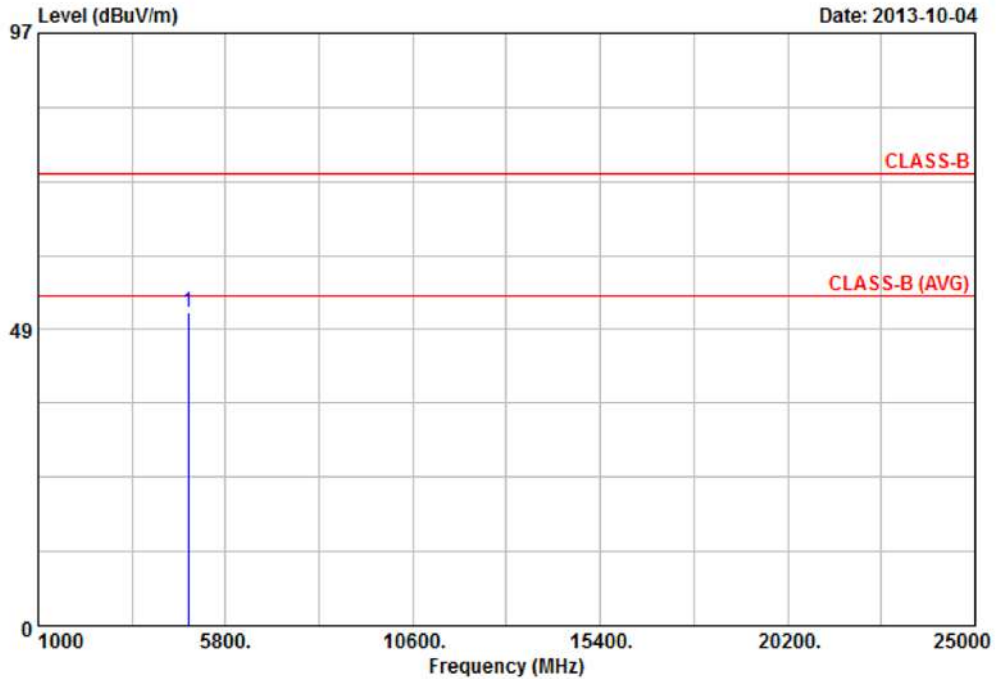

Item	Freq	Read Value	Factor	Result	Limit	Margin	Remark	Ant Pos	Tab Pos
	MHz	dBuV	dB/m	dBuV/m	dBuV/m	dB		cm	Deg
1	4843.39	45.11	6.22	51.33	74.00	-22.67	Peak	101	360

Notes:

1. Result = Read Value + Factor
2. Factor = Antenna Factor + Cable Loss - Amplifier
3. The resolution bandwidth of test receiver/spectrum analyzer is 120KHz and video bandwidth is 300kHz for Peak detection and Quasi-peak detection at frequency below 1GHz.
4. The resolution bandwidth of test receiver/spectrum analyzer is 1MHz and video bandwidth is 3MHz for Peak detection at frequency above 1GHz.
5. The resolution bandwidth of test receiver/spectrum analyzer is 1MHz and video bandwidth is 3MHz (detector sample mode) for Average detection at frequency above 1GHz.
6. The other emissions is too low to be measured.
7. The data is worse case.



Power	: AC 120V	Pol/Phase	: HORIZONTAL
Test Mode 3	: 802.11n HT40, CH3	Temperature	: 25 °C
Memo	:	Humidity	: 65 %

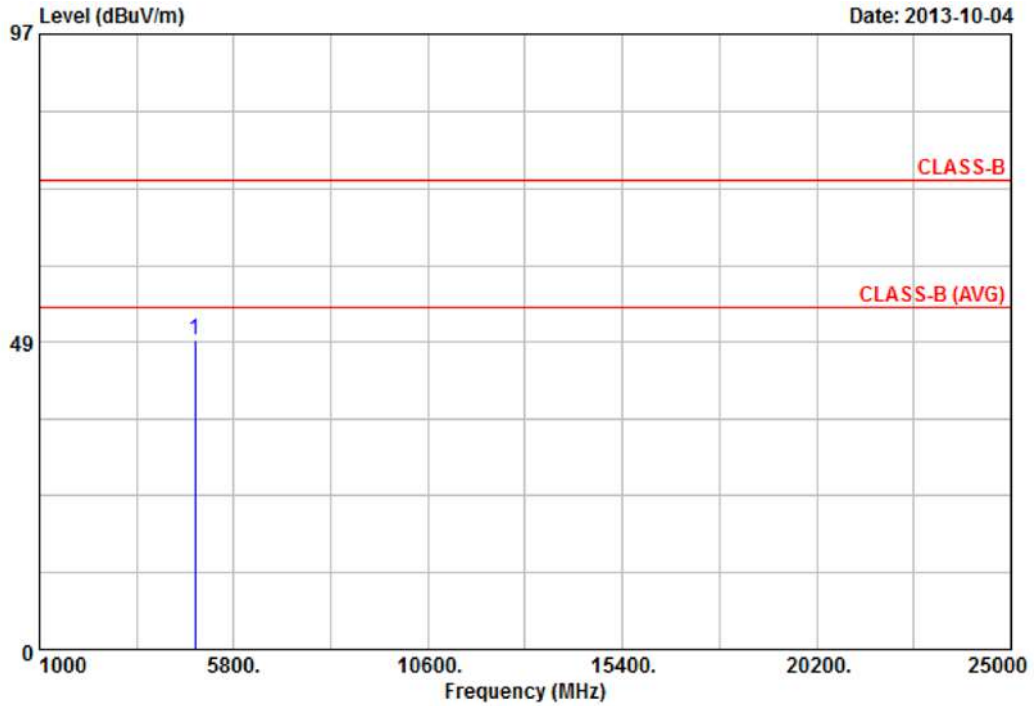

Item	Freq	Read Value	Factor	Result	Limit	Margin	Remark	Ant Pos	Tab Pos
	MHz	dBuV	dB/m	dBuV/m	dBuV/m	dB		cm	Deg
1	4843.25	44.53	4.48	49.01	74.00	-24.99	Peak	101	0

Notes:

1. Result = Read Value + Factor
2. Factor = Antenna Factor + Cable Loss - Amplifier
3. The resolution bandwidth of test receiver/spectrum analyzer is 120KHz and video bandwidth is 300kHz for Peak detection and Quasi-peak detection at frequency below 1GHz.
4. The resolution bandwidth of test receiver/spectrum analyzer is 1MHz and video bandwidth is 3MHz for Peak detection at frequency above 1GHz.
5. The resolution bandwidth of test receiver/spectrum analyzer is 1MHz and video bandwidth is 3MHz (detector sample mode) for Average detection at frequency above 1GHz.
6. The other emissions is too low to be measured.
7. The data is worse case.



Power	: AC 120V	Pol/Phase	: VERTICAL
Test Mode 3	: 802.11n HT40, CH6	Temperature	: 25 °C
Memo	:	Humidity	: 65 %

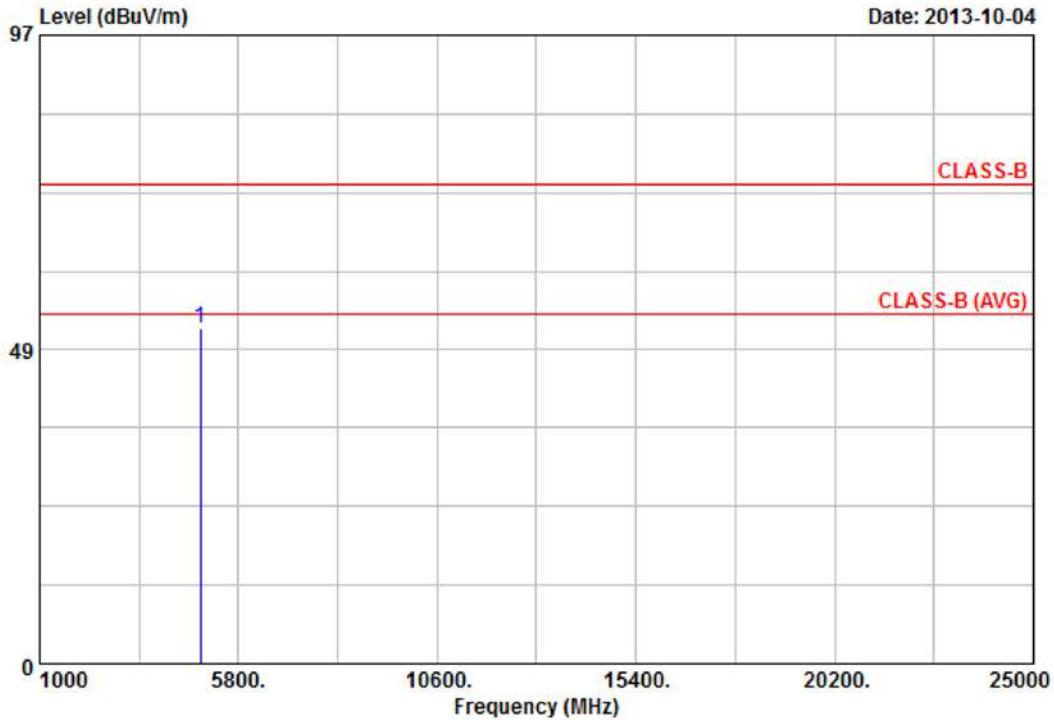

Item	Freq	Read Value	Factor	Result	Limit	Margin	Remark	Ant Pos	Tab Pos
	MHz	dBuV	dB/m	dBuV/m	dBuV/m	dB		cm	Deg
1	4874.05	45.06	6.83	51.89	74.00	-22.11	Peak	101	360

Notes:

1. Result = Read Value + Factor
2. Factor = Antenna Factor + Cable Loss - Amplifier
3. The resolution bandwidth of test receiver/spectrum analyzer is 120KHz and video bandwidth is 300kHz for Peak detection and Quasi-peak detection at frequency below 1GHz.
4. The resolution bandwidth of test receiver/spectrum analyzer is 1MHz and video bandwidth is 3MHz for Peak detection at frequency above 1GHz.
5. The resolution bandwidth of test receiver/spectrum analyzer is 1MHz and video bandwidth is 3MHz (detector sample mode) for Average detection at frequency above 1GHz.
6. The other emissions is too low to be measured.
7. The data is worse case.





Power	: AC 120V	Pol/Phase	: HORIZONTAL
Test Mode 3	: 802.11n HT40, CH6	Temperature	: 25 °C
Memo	:	Humidity	: 65 %

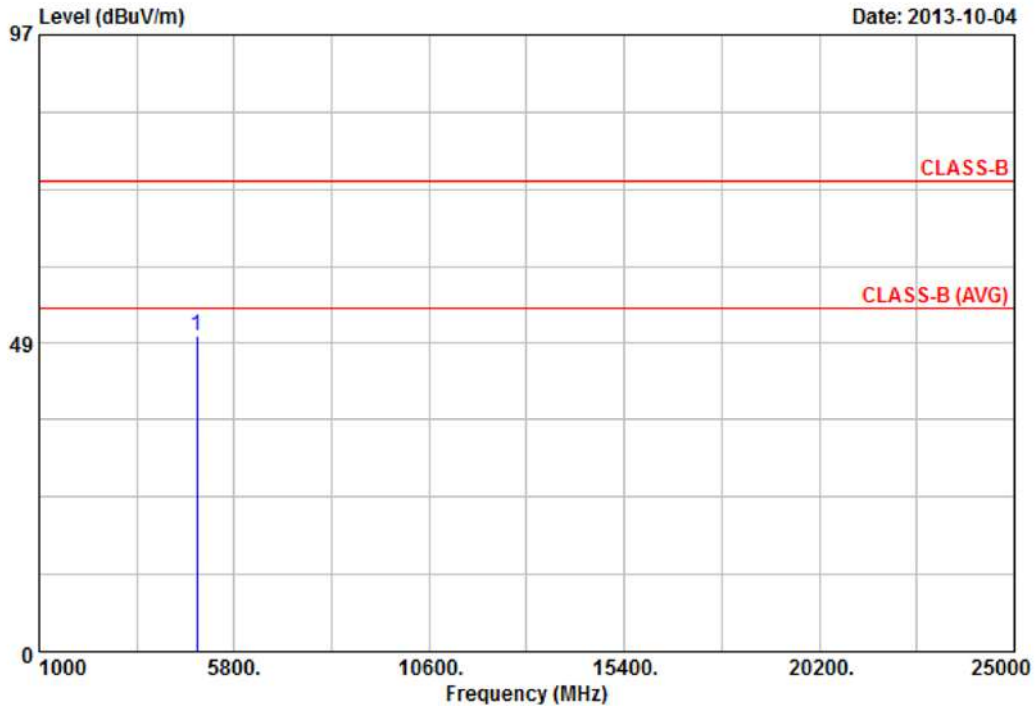

Item	Freq	Read Value	Factor	Result	Limit	Margin	Remark	Ant Pos	Tab Pos
	MHz	dBuV	dB/m	dBuV/m	dBuV/m	dB		cm	Deg
1	4873.31	44.70	4.96	49.66	74.00	-24.34	Peak	101	0

Notes:

1. Result = Read Value + Factor
2. Factor = Antenna Factor + Cable Loss - Amplifier
3. The resolution bandwidth of test receiver/spectrum analyzer is 120KHz and video bandwidth is 300kHz for Peak detection and Quasi-peak detection at frequency below 1GHz.
4. The resolution bandwidth of test receiver/spectrum analyzer is 1MHz and video bandwidth is 3MHz for Peak detection at frequency above 1GHz.
5. The resolution bandwidth of test receiver/spectrum analyzer is 1MHz and video bandwidth is 3MHz (detector sample mode) for Average detection at frequency above 1GHz.
6. The other emissions is too low to be measured.
7. The data is worse case.





Power	: AC 120V	Pol/Phase	: VERTICAL
Test Mode 3	: 802.11n HT40, CH9	Temperature	: 25 °C
Memo	:	Humidity	: 65 %

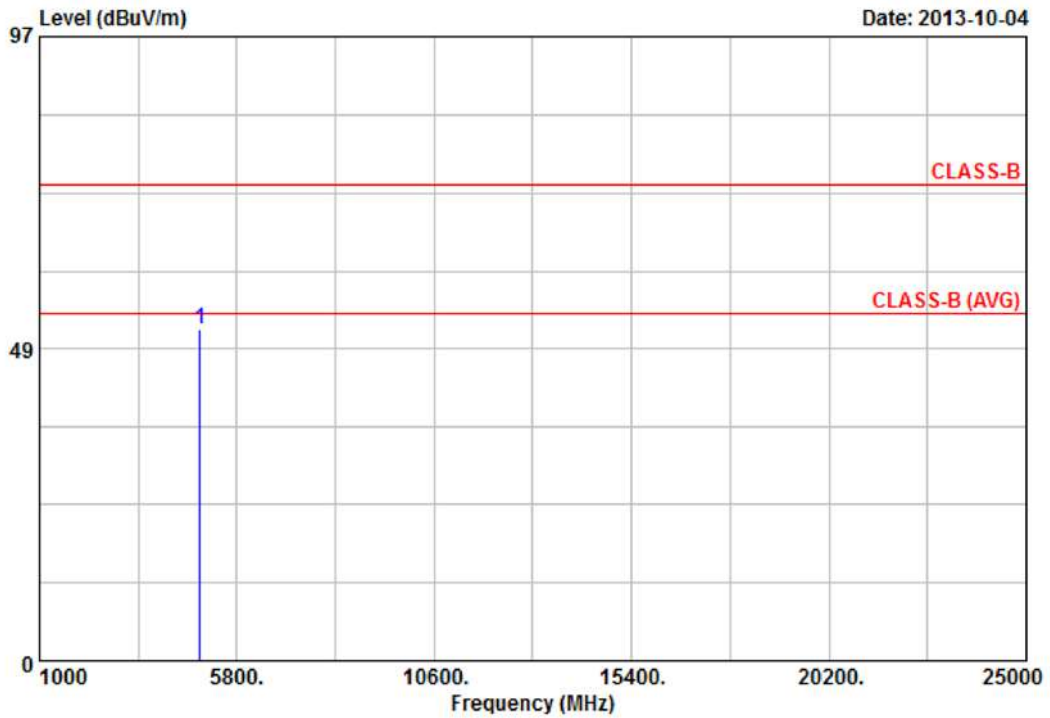

Item	Freq	Read Value	Factor	Result	Limit	Margin	Remark	Ant Pos	Tab Pos
	MHz	dBuV	dB/m	dBuV/m	dBuV/m	dB		cm	Deg
1	4904.57	44.17	7.36	51.53	74.00	-22.47	Peak	101	360

Notes:

1. Result = Read Value + Factor
2. Factor = Antenna Factor + Cable Loss - Amplifier
3. The resolution bandwidth of test receiver/spectrum analyzer is 120KHz and video bandwidth is 300kHz for Peak detection and Quasi-peak detection at frequency below 1GHz.
4. The resolution bandwidth of test receiver/spectrum analyzer is 1MHz and video bandwidth is 3MHz for Peak detection at frequency above 1GHz.
5. The resolution bandwidth of test receiver/spectrum analyzer is 1MHz and video bandwidth is 3MHz (detector sample mode) for Average detection at frequency above 1GHz.
6. The other emissions is too low to be measured.
7. The data is worse case.



Power	: AC 120V	Pol/Phase	: HORIZONTAL
Test Mode 3	: 802.11n HT40, CH9	Temperature	: 25 °C
Memo	:	Humidity	: 65 %

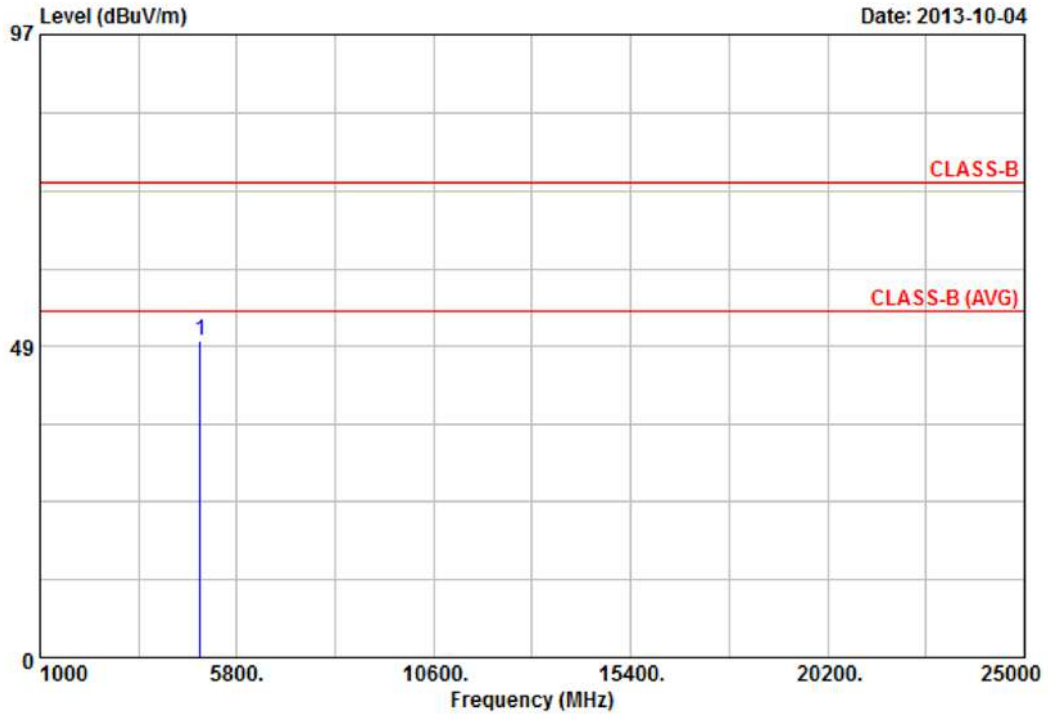

Item	Freq	Read Value	Factor	Result	Limit	Margin	Remark	Ant Pos	Tab Pos
	MHz	dBuV	dB/m	dBuV/m	dBuV/m	dB		cm	Deg
1	4904.07	44.20	5.38	49.58	74.00	-24.42	Peak	101	0

Notes:

1. Result = Read Value + Factor
2. Factor = Antenna Factor + Cable Loss - Amplifier
3. The resolution bandwidth of test receiver/spectrum analyzer is 120KHz and video bandwidth is 300kHz for Peak detection and Quasi-peak detection at frequency below 1GHz.
4. The resolution bandwidth of test receiver/spectrum analyzer is 1MHz and video bandwidth is 3MHz for Peak detection at frequency above 1GHz.
5. The resolution bandwidth of test receiver/spectrum analyzer is 1MHz and video bandwidth is 3MHz (detector sample mode) for Average detection at frequency above 1GHz.
6. The other emissions is too low to be measured.
7. The data is worse case.