



TEST REPORT

Report Reference No...... : **TRE1810019206** R/C.....:79145
FCC ID..... : **ZSW-30-076**
Applicant's name..... : **b mobile HK Limited**
Address..... : Flat 18; 14/F Block 1; Golden Industrial Building;16-26 Kwai Tak Street; Kwai Chung; New Territories; Hong Kong.
Manufacturer..... : b mobile HK Limited
Address..... : Flat 18; 14/F Block 1; Golden Industrial Building;16-26 Kwai Tak Street; Kwai Chung; New Territories; Hong Kong.
Test item description : **Mobile Phone**
Trade Mark : Bmobile
Model/Type reference..... : AX686
Listed Model(s) : -
Standard : **47 CFR FCC Part 15 Subpart B**
Date of receipt of test sample..... : Oct 23,2018
Date of testing..... : Oct 24,2018- Nov 14,2018
Date of issue..... : Nov 15,2018
Result..... : **Pass**

Compiled by
 (position+printed name+signature)..: File administrators Silvia Li *Silvia Li*
 Supervised by
 (position+printed name+signature)..: Project Engineer Aaron Fang *Aaron Fang*
 Approved by
 (position+printed name+signature)..: RF Manager Hans Hu *Hans Hu*

Testing Laboratory Name : **Shenzhen Huatongwei International Inspection Co., Ltd.**
Address..... : 1/F, Bldg 3, Hongfa Hi-tech Industrial Park, Genyu Road, Tianliao, Gongming, Shenzhen, China

Shenzhen Huatongwei International Inspection Co., Ltd. All rights reserved.

This publication may be reproduced in whole or in part for non-commercial purposes as long as the Shenzhen Huatongwei International Inspection Co., Ltd. is acknowledged as copyright owner and source of the material. Shenzhen Huatongwei International Inspection Co., Ltd. takes no responsibility for and will not assume liability for damages resulting from the reader's interpretation of the reproduced material due to its placement and context.

The test report merely corresponds to the test sample.

Contents

| | | |
|-----------|---|------------------|
| 1. | <u>TEST STANDARDS AND REPORT VERSION</u> | <u>3</u> |
| 1.1. | Test Standards | 3 |
| 1.2. | Report version information | 3 |
| 2. | <u>TEST DESCRIPTION</u> | <u>4</u> |
| 3. | <u>SUMMARY.....</u> | <u>5</u> |
| 3.1. | Client Information | 5 |
| 3.2. | Product Description | 5 |
| 3.3. | EUT operation mode | 5 |
| 3.4. | Configuration of Tested System | 5 |
| 3.5. | Support unit used in test configuration | 6 |
| 4. | <u>TEST ENVIRONMENT</u> | <u>7</u> |
| 4.1. | Address of the test laboratory | 7 |
| 4.2. | Test Facility | 7 |
| 4.3. | Environmental conditions | 8 |
| 4.4. | Statement of the measurement uncertainty | 8 |
| 4.5. | Equipments Used during the Test | 9 |
| 5. | <u>TEST CONDITIONS AND RESULTS</u> | <u>10</u> |
| 5.1. | Conducted Emissions Test | 10 |
| 5.2. | Radiated Emissions Test | 13 |
| 6. | <u>TEST SETUP PHOTOS OF THE EUT</u> | <u>17</u> |
| 7. | <u>EXTERNAL AND INTERNAL PHOTOS OF THE EUT</u> | <u>18</u> |

1. TEST STANDARDS AND REPORT VERSION

1.1. Test Standards

The tests were performed according to following standards:

[47 CFR FCC Part 15 Subpart B](#) - Unintentional Radiators

[ANSI C63.4: 2014](#) – American National Standard for Methods of Measurement of Radio-Noise Emissions from Low-Voltage Electrical and Electronic Equipment in the Range of 9 kHz to 40GHz

1.2. Report version information

| Revision No. | Date of issue | Description |
|--------------|---------------|-------------|
| N/A | 2018-11-15 | Original |
| | | |
| | | |
| | | |
| | | |

2. TEST DESCRIPTION

| Test Item | Section in CFR 47 | Result | Test Engineer |
|---------------------|-------------------|--------|---------------|
| Conducted Emissions | 15.107(a) | Pass | Tony Duan |
| Radiated Emissions | 15.109(a) | Pass | Michael Jie |

Note: The measurement uncertainty is not included in the test result.

3. SUMMARY

3.1. Client Information

| | |
|---------------|--|
| Applicant: | b mobile HK Limited |
| Address: | Flat 18; 14/F Block 1; Golden Industrial Building;16-26 Kwai Tak Street; Kwai Chung; New Territories; Hong Kong. |
| Manufacturer: | b mobile HK Limited |
| Address: | Flat 18; 14/F Block 1; Golden Industrial Building;16-26 Kwai Tak Street; Kwai Chung; New Territories; Hong Kong. |

3.2. Product Description

| | |
|----------------------|---|
| Name of EUT: | Mobile Phone |
| Trade Mark: | Bmobile |
| Model No.: | AX686 |
| Listed Model(s) | - |
| Power supply: | DC 3.7V |
| Adapter information: | Input:100-240Va.c. 50/60Hz 0.15A Output:5.0Vd.c. 700mA |

3.3. EUT operation mode

| Test mode | Describe |
|-----------------------|--|
| Camera recording mode | Keep the EUT in Camera recording status |
| Video Playing mode | Keep the EUT in Video Playing status |
| Data exchange mode | Keep the EUT in Data exchange with PC status |

Pre-scan all of above modes. Only show data exchange mode for radiated emission, and camera recording mode for conducted emission, which is the worst case on the report.

3.4. Configuration of Tested System

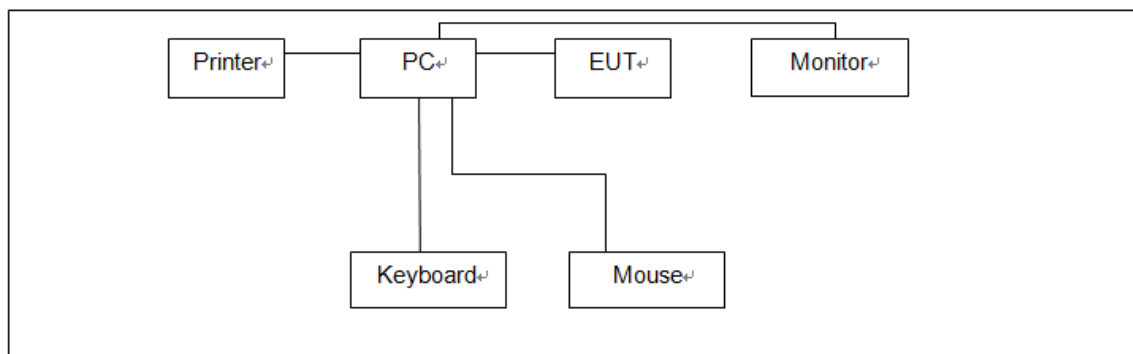

3.5. Support unit used in test configuration

| Item | Equipment | Manufacturer | Model No. | FCC ID / FCC DoC | Data Cable | Power Cord |
|------|-----------|--------------|------------------|---------------------|---------------------|--------------------|
| 1 | PC | DELL | OptiPlex 3020 MT | FCC DoC | N/A | Unshielded 1.8m |
| 2 | Monitor | DELL | E1912Hf | FCC DoC | N/A | Unshielded 1.8m |
| 3 | Keyboard | DELL | SK8115 | FCC DoC | Unshielded, 1.5m | N/A |
| 4 | Mouse | DELL | MS111-T | FCC DoC | Unshielded, 1.5m | N/A |
| 5 | Printer | EPSON | L101 | FCC DoC | N/A | Unshielded 1.8m |

4. TEST ENVIRONMENT

4.1. Address of the test laboratory

Laboratory: Shenzhen Huatongwei International Inspection Co., Ltd.

Address: 1/F, Bldg 3, Hongfa Hi-tech Industrial Park, Genyu Road, Tianliao, Gongming, Shenzhen, China

Phone: 86-755-26748019 Fax: 86-755-26748089

4.2. Test Facility

The test facility is recognized, certified, or accredited by the following organizations:

CNAS-Lab Code: L1225

Shenzhen Huatongwei International Inspection Co., Ltd. has been assessed and proved to be in compliance with CNAS-CL01 Accreditation Criteria for Testing and Calibration Laboratories (identical to ISO/IEC17025: 2005 General Requirements) for the Competence of Testing and Calibration Laboratories.

A2LA-Lab Cert. No. 3902.01

Shenzhen Huatongwei International Inspection Co., Ltd. EMC Laboratory has been accredited by A2LA for technical competence in the field of electrical testing, and proved to be in compliance with ISO/IEC 17025: 2005 General Requirements for the Competence of Testing and Calibration Laboratories and any additional program requirements in the identified field of testing.

FCC-Registration No.: 762235

Shenzhen Huatongwei International Inspection Co., Ltd. EMC Laboratory has been registered and fully described in a report filed with the FCC (Federal Communications Commission). The acceptance letter from the FCC is maintained in our files. Registration 762235.

IC-Registration No.: 5377B-1

Two 3m Alternate Test Site of Shenzhen Huatongwei International Inspection Co., Ltd. has been registered by Certification and Engineering Bureau of Industry Canada for the performance of radiated measurements with Registration No. 5377B-1.

ACA

Shenzhen Huatongwei International Inspection Co., Ltd. EMC Laboratory can also perform testing for the Australian C-Tick mark as a result of our A2LA accreditation.

4.3. Environmental conditions

During the measurement the environmental conditions were within the listed ranges:

| | |
|--------------------|-------------|
| Temperature: | 15~35°C |
| Relative Humidity: | 30~60 % |
| Air Pressure: | 950~1050mba |

4.4. Statement of the measurement uncertainty

The data and results referenced in this document are true and accurate. The reader is cautioned that there may be errors within the calibration limits of the equipment and facilities. The measurement uncertainty was calculated for all measurements listed in this test report acc. to CISPR 16 - 4 „Specification for radio disturbance and immunity measuring apparatus and methods – Part 4: Uncertainty in EMC Measurements“ and is documented in the Shenzhen Huatongwei International Inspection Co., Ltd quality system acc. to DIN EN ISO/IEC 17025. Furthermore, component and process variability of devices similar to that tested may result in additional deviation. The manufacturer has the sole responsibility of continued compliance of the device.

Hereafter the best measurement capability for Shenzhen Huatongwei laboratory is reported:

| Test | Range | Measurement Uncertainty | Notes |
|-----------------------|------------|-------------------------|-------|
| Radiated Emissions | 30~1000MHz | 4.28 dB | (1) |
| Radiated Emissions | 1~18GHz | 5.16 dB | (1) |
| Conducted Disturbance | 0.15~30MHz | 3.35 dB | (1) |

(1) This uncertainty represents an expanded uncertainty expressed at approximately the 95% confidence level using a coverage factor of k=2.

4.5. Equipments Used during the Test

| Conducted Emissions | | | | | | |
|----------------------------|---------------------------|--------------|-----------|------------|-------------------------|-------------------------|
| Item | Test Equipment | Manufacturer | Model No. | Serial No. | Last Cal. (mm-dd-yy) | Next Cal. (mm-dd-yy) |
| 1 | EMI Test Receiver | R&S | ESCI | 101247 | 10/27/2018 | 10/26/2019 |
| 2 | Artificial Mains | SCHWARZBECK | NNLK 8121 | 573 | 10/27/2018 | 10/26/2019 |
| 3 | 2-Line V- Network | R&S | ESH3-Z5 | 100049 | 10/27/2018 | 10/26/2019 |
| 4 | Pulse Limiter | R&S | ESH3-Z2 | 101488 | 10/27/2018 | 10/26/2019 |
| 5 | RF Connection Cable | HUBER+SUHNER | EF400 | N/A | 11/14/2017 | 11/13/2019 |
| 6 | Test Software | R&S | ES-K1 | N/A | N/A | N/A |

| Radiated Emissions | | | | | | |
|---------------------------|--------------------------------|--------------------|--------------|-----------------|-------------------------|-------------------------|
| Item | Test Equipment | Manufacturer | Model No. | Serial No. | Last Cal. (mm-dd-yy) | Next Cal. (mm-dd-yy) |
| 1 | Semi- Anechoic Chamber | Albatross projects | SAC-3m-01 | C11121 | 10/16/2016 | 10/15/2019 |
| 2 | EMI Test Receiver | R&S | ESCI | 100900 | 10/28/2018 | 10/27/2019 |
| 3 | Loop Antenna | R&S | HFH2-Z2 | 100020 | 11/20/2017 | 11/19/2020 |
| 4 | Ultra- Broadband Antenna | SCHWARZBECK | VULB9163 | 538 | 4/5/2017 | 4/4/2020 |
| 5 | Horn Antenna | SCHWARZBECK | 9120D | 1011 | 3/27/2017 | 3/26/2020 |
| 6 | Broadband Horn Antenna | SCHWARZBECK | BBHA9170 | BBHA9170 472 | 3/27/2017 | 3/26/2020 |
| 7 | Pre-amplifier | SCHWARZBECK | BBV 9743 | 9743-0022 | 10/17/2018 | 10/16/2019 |
| 8 | Broadband Pre-amplifier | SCHWARZBECK | BBV 9718 | 9718-248 | 4/28/2018 | 4/28/2019 |
| 9 | Spectrum Analyzer | R&S | FSP40 | 100597 | 10/27/2018 | 10/26/2019 |
| 10 | RF Connection Cable | HUBER+SUHNE R | RE-7-FL | N/A | 11/21/2017 | 11/20/2018 |
| 11 | RF Connection Cable | HUBER+SUHNE R | RE-7-FH | N/A | 11/21/2017 | 11/20/2018 |
| 12 | Test Software | Audix | E3 | N/A | N/A | N/A |
| 13 | Test Software | R&S | ES-K1 | N/A | N/A | N/A |
| 14 | Turntable | Maturo Germany | TT2.0-1T | N/A | N/A | N/A |
| 15 | Antenna Mast | Maturo Germany | CAM-4.0-P-12 | N/A | N/A | N/A |

5. TEST CONDITIONS AND RESULTS

5.1. Conducted Emissions Test

LIMIT

FCC CFR Title 47 Part 15 Subpart B Section 15.107:

| Frequency range (MHz) | Limit (dBuV) | |
|-----------------------|--------------|-----------|
| | Quasi-peak | Average |
| 0.15-0.5 | 66 to 56* | 56 to 46* |
| 0.5-5 | 56 | 46 |
| 5-30 | 60 | 50 |

* Decreases with the logarithm of the frequency.

TEST CONFIGURATION

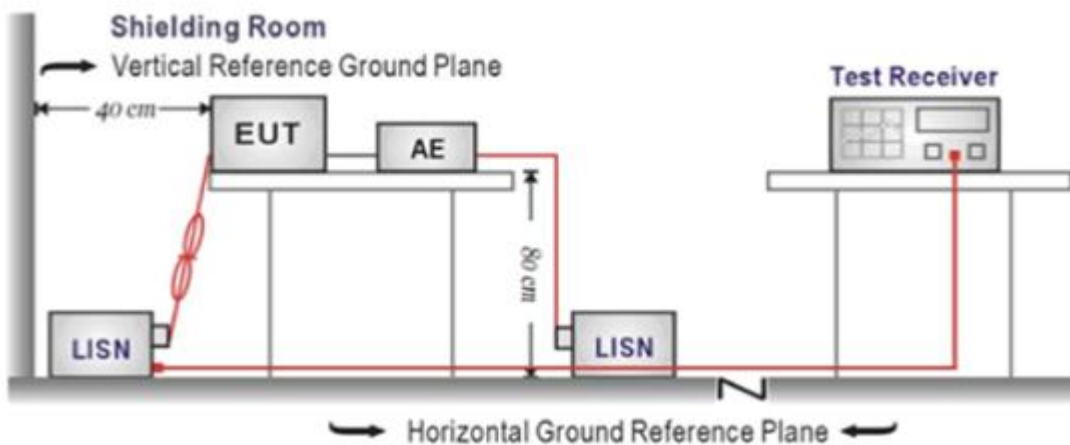

TEST PROCEDURE

1. The EUT was setup according to ANSI C63.4:2014
2. The EUT was placed on a platform of nominal size, 1 m by 1.5 m, raised 10 cm above the conducting ground plane. The vertical conducting plane was located 40 cm to the rear of the EUT. All other surfaces of EUT were at least 10 cm from any other grounded conducting surface.
3. The EUT and simulators are connected to the main power through a line impedance stabilization network (LISN). The LISN provides a 50ohm / 50uH coupling impedance for the measuring equipment.
4. The peripheral devices are also connected to the main power through a LISN. (Please refer to the block diagram of the test setup and photographs)
5. Each current-carrying conductor of the EUT power cord, except the ground (safety) conductor, was individually connected through a LISN to the input power source.
6. The excess length of the power cord between the EUT and the LISN receptacle were folded back and forth at the center of the lead to form a bundle not exceeding 40 cm in length.
7. Conducted emissions were investigated over the frequency range from 0.15MHz to 30MHz using a receiver bandwidth of 9 kHz.
8. During the above scans, the emissions were maximized by cable manipulation.

TEST MODE:

Please refer to the clause 3.3

TEST RESULTS

Passed Not Applicable

Test Line:

L

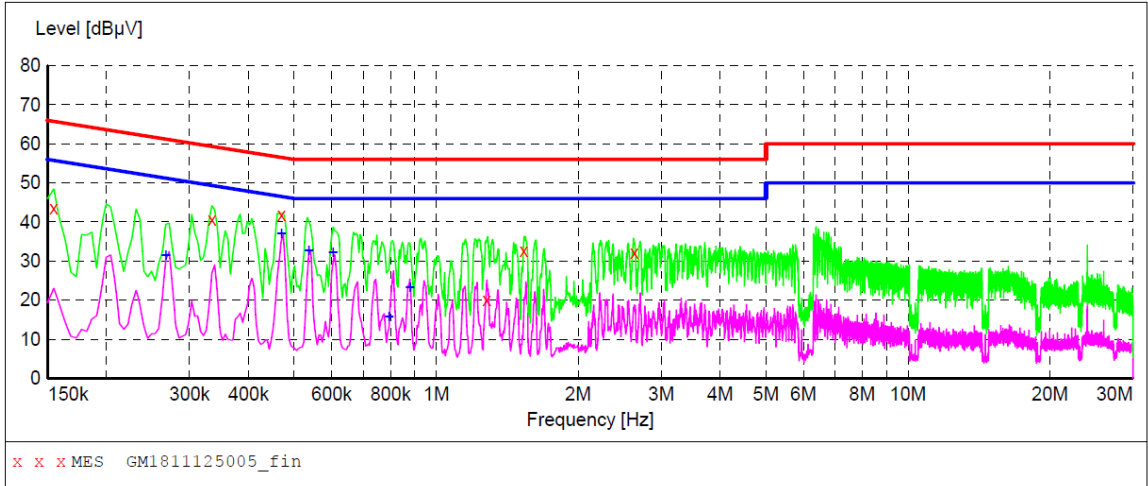

MEASUREMENT RESULT: "GM1811125005_fin"

11/12/2018 9:45AM

| Frequency MHz | Level dBµV | Transd dB | Limit dBµV | Margin dB | Detector | Line | PE |
|------------------|---------------|--------------|---------------|--------------|----------|------|-----|
| 0.154500 | 43.60 | 10.1 | 66 | 22.2 | QP | L1 | GND |
| 0.334500 | 40.70 | 10.1 | 59 | 18.6 | QP | L1 | GND |
| 0.469500 | 41.80 | 10.1 | 57 | 14.7 | QP | L1 | GND |
| 1.279500 | 20.10 | 10.0 | 56 | 35.9 | QP | L1 | GND |
| 1.531500 | 32.70 | 10.0 | 56 | 23.3 | QP | L1 | GND |
| 2.629500 | 32.10 | 10.0 | 56 | 23.9 | QP | L1 | GND |

MEASUREMENT RESULT: "GM1811125005_fin2"

11/12/2018 9:45AM

| Frequency MHz | Level dBµV | Transd dB | Limit dBµV | Margin dB | Detector | Line | PE |
|------------------|---------------|--------------|---------------|--------------|----------|------|-----|
| 0.267000 | 31.50 | 10.2 | 51 | 19.7 | AV | L1 | GND |
| 0.469500 | 36.90 | 10.1 | 47 | 9.6 | AV | L1 | GND |
| 0.537000 | 32.60 | 10.0 | 46 | 13.4 | AV | L1 | GND |
| 0.604500 | 32.10 | 10.0 | 46 | 13.9 | AV | L1 | GND |
| 0.793500 | 15.80 | 9.9 | 46 | 30.2 | AV | L1 | GND |
| 0.879000 | 23.30 | 9.9 | 46 | 22.7 | AV | L1 | GND |

Test Line:

N

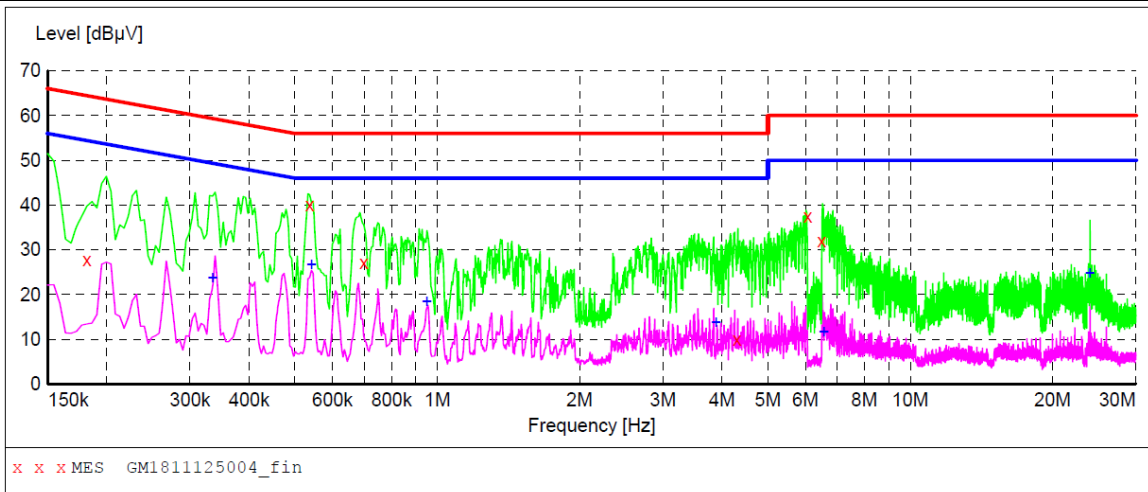

MEASUREMENT RESULT: "GM1811125004_fin"

11/12/2018 9:42AM

| Frequency MHz | Level dBµV | Transd dB | Limit dBµV | Margin dB | Detector | Line | PE |
|------------------|---------------|--------------|---------------|--------------|----------|------|-----|
| 0.181500 | 27.70 | 10.1 | 64 | 36.7 | QP | N | GND |
| 0.537000 | 39.90 | 10.0 | 56 | 16.1 | QP | N | GND |
| 0.699000 | 27.10 | 10.0 | 56 | 28.9 | QP | N | GND |
| 4.303500 | 9.90 | 10.0 | 56 | 46.1 | QP | N | GND |
| 6.067500 | 37.50 | 10.0 | 60 | 22.5 | QP | N | GND |
| 6.495000 | 32.00 | 10.0 | 60 | 28.0 | QP | N | GND |

MEASUREMENT RESULT: "GM1811125004_fin2"

11/12/2018 9:42AM

| Frequency MHz | Level dBµV | Transd dB | Limit dBµV | Margin dB | Detector | Line | PE |
|------------------|---------------|--------------|---------------|--------------|----------|------|-----|
| 0.334500 | 23.70 | 10.1 | 49 | 25.6 | AV | N | GND |
| 0.541500 | 26.60 | 10.0 | 46 | 19.4 | AV | N | GND |
| 0.951000 | 18.50 | 9.9 | 46 | 27.5 | AV | N | GND |
| 3.885000 | 13.70 | 10.0 | 46 | 32.3 | AV | N | GND |
| 6.567000 | 11.70 | 10.0 | 50 | 38.3 | AV | N | GND |
| 24.000000 | 24.90 | 10.4 | 50 | 25.1 | AV | N | GND |

5.2. Radiated Emissions Test

LIMIT

FCC CFR Title 47 Part 15 Subpart B Section 15.109

| Frequency | Limit (dBuV/m @3m) | Value |
|---------------|--------------------|------------|
| 30MHz-88MHz | 40.00 | Quasi-peak |
| 88MHz-216MHz | 43.50 | Quasi-peak |
| 216MHz-960MHz | 46.00 | Quasi-peak |
| 960MHz-1GHz | 54.00 | Quasi-peak |
| Above 1GHz | 54.00 | Average |
| | 74.00 | Peak |

TEST CONFIGURATION

➤ 30MHz ~ 1GHz

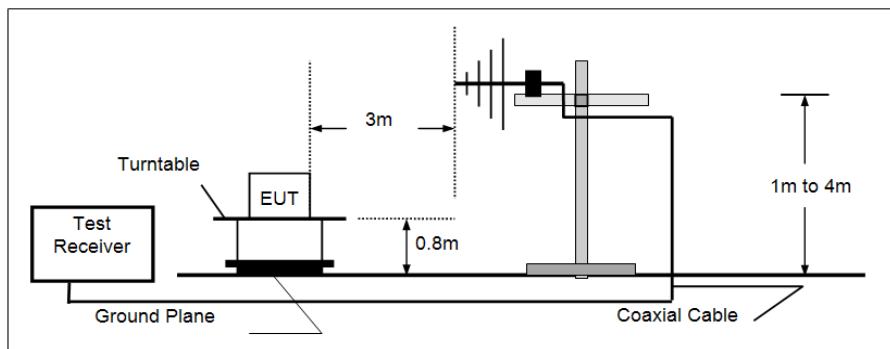

➤ Above 1GHz

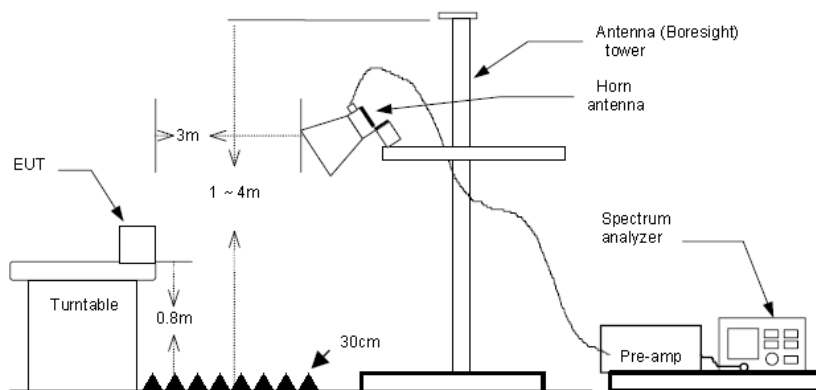

TEST PROCEDURE

1. The EUT was tested according to ANSI C63.4:2014.
2. The EUT is placed on a turn table which is 0.8 meter above ground.
3. The turn table is rotated 360 degrees to determine the position of the maximum emission level.
4. The EUT was positioned such that the distance from antenna to the EUT was 3 meters.
5. The antenna is scanned from 1 meter to 4 meters to find out the maximum emission level. This is repeated for both horizontal and vertical polarization of the antenna.
6. Use the following spectrum analyzer settings
 - (1) Span shall wide enough to fully capture the emission being measured;
 - (2) Below 1GHz,
 RBW=120KHz, VBW=300KHz, Sweep=auto, Detector function=peak, Trace=max hold;
 If the emission level of the EUT measured by the peak detector is 3 dB lower than the applicable limit, the peak emission level will be reported. Otherwise, the emission measurement will be repeated using the quasi-peak detector and reported.
 - (3) From 1GHz to 5th harmonic, RBW=1MHz, VBW=3MHz

TEST MODE:

Please refer to the clause 3.3

TEST RESULTS

Passed **Not Applicable**

Note: Final Level =Receiver Read level + Antenna Factor + Cable Loss – Preamplifier Factor

Polarization: Horizontal

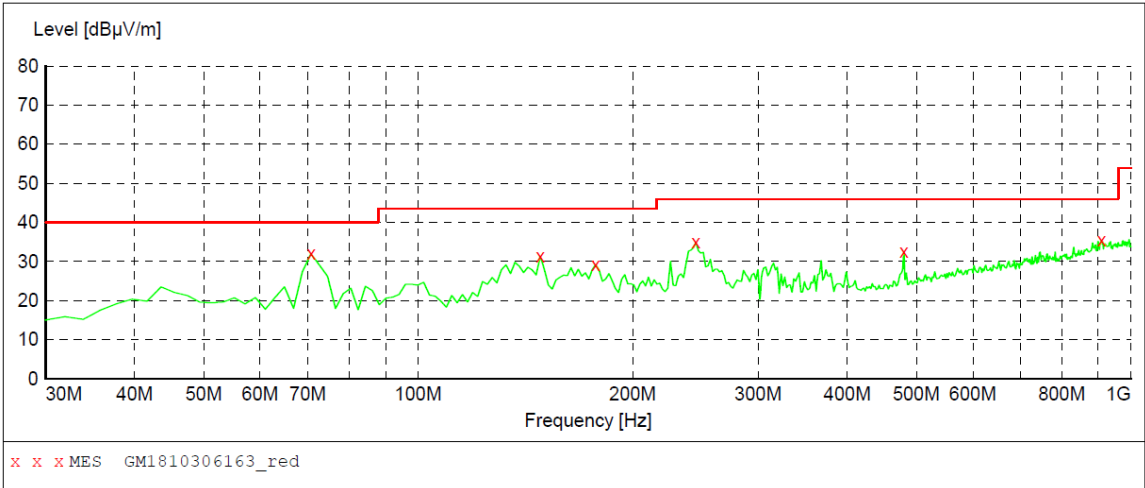

MEASUREMENT RESULT: "GM1810306163_red"

10/31/2018 12:23AM

| Frequency MHz | Level dBµV/m | Transd dB | Limit dBµV/m | Margin dB | Det. | Height cm | Azimuth deg | Polarization |
|---------------|--------------|-----------|--------------|-----------|------|-----------|-------------|--------------|
| 70.740000 | 32.00 | -13.2 | 40.0 | 8.0 | QP | 300.0 | 238.00 | HORIZONTAL |
| 148.340000 | 31.30 | -13.6 | 43.5 | 12.2 | QP | 100.0 | 73.00 | HORIZONTAL |
| 177.440000 | 29.20 | -12.2 | 43.5 | 14.3 | QP | 100.0 | 288.00 | HORIZONTAL |
| 245.340000 | 34.90 | -8.2 | 46.0 | 11.1 | QP | 100.0 | 288.00 | HORIZONTAL |
| 480.080000 | 32.50 | -2.0 | 46.0 | 13.5 | QP | 100.0 | 288.00 | HORIZONTAL |
| 908.820000 | 35.40 | 7.7 | 46.0 | 10.6 | QP | 100.0 | 340.00 | HORIZONTAL |

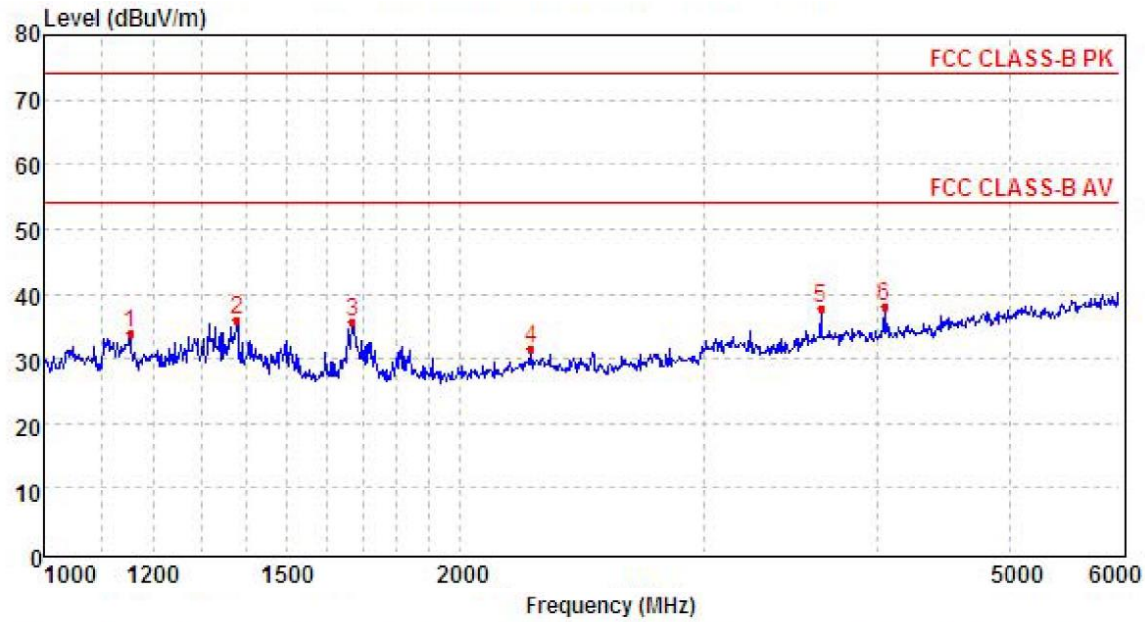

| Mark | Frequency MHz | Reading dBuV/m | Antenna dB | Cable dB | Preamp dB | Level dBuV/m | Limit dBuV/m | Over limit | Remark |
|------|---------------|----------------|------------|----------|-----------|--------------|--------------|------------|--------|
| 1 | 1154.12 | 40.7 | 25.9 | 4.6 | 37.3 | 33.9 | 74.0 | -40.1 | Peak |
| 2 | 1378.13 | 42.1 | 26.0 | 5.0 | 37.1 | 36.0 | 74.0 | -38.0 | Peak |
| 3 | 1672.36 | 42.3 | 25.1 | 5.7 | 37.3 | 35.8 | 74.0 | -38.2 | Peak |
| 4 | 2251.66 | 34.9 | 27.8 | 6.5 | 37.6 | 31.6 | 74.0 | -42.4 | Peak |
| 5 | 3646.07 | 37.2 | 29.3 | 8.3 | 37.0 | 37.8 | 74.0 | -36.2 | Peak |
| 6 | 4052.62 | 36.3 | 29.8 | 8.8 | 36.7 | 38.2 | 74.0 | -35.8 | Peak |

Polarization: Vertical

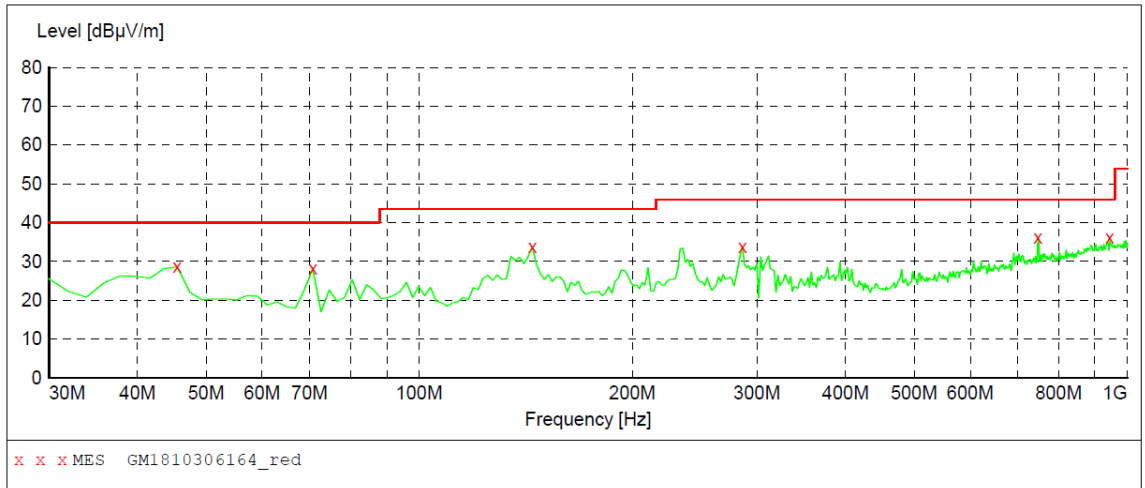

MEASUREMENT RESULT: "GM1810306164_red"

10/31/2018 12:26AM

| Frequency MHz | Level dBuV/m | Transd dB | Limit dBuV/m | Margin dB | Det. | Height cm | Azimuth deg | Polarization |
|---------------|--------------|-----------|--------------|-----------|------|-----------|-------------|--------------|
| 45.520000 | 28.60 | -8.7 | 40.0 | 11.4 | QP | 100.0 | 359.00 | VERTICAL |
| 70.740000 | 28.10 | -13.2 | 40.0 | 11.9 | QP | 100.0 | 196.00 | VERTICAL |
| 144.460000 | 33.70 | -13.7 | 43.5 | 9.8 | QP | 100.0 | 0.00 | VERTICAL |
| 286.080000 | 33.80 | -7.2 | 46.0 | 12.2 | QP | 100.0 | 159.00 | VERTICAL |
| 747.800000 | 36.20 | 4.6 | 46.0 | 9.8 | QP | 100.0 | 236.00 | VERTICAL |
| 943.740000 | 36.20 | 8.1 | 46.0 | 9.8 | QP | 100.0 | 236.00 | VERTICAL |

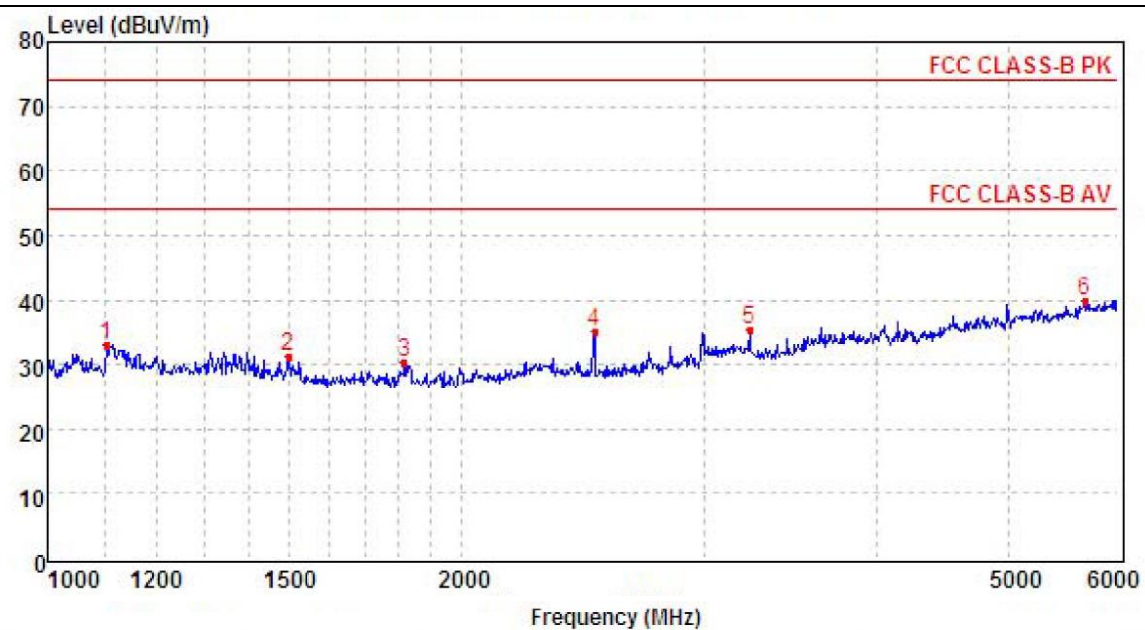

| Mark | Frequency MHz | Reading dBuV/m | Antenna dB | Cable dB | Preamp dB | Level dBuV/m | Limit dBuV/m | Over limit | Remark |
|------|---------------|----------------|------------|----------|-----------|--------------|--------------|------------|--------|
| 1 | 1103.57 | 40.5 | 25.5 | 4.4 | 37.3 | 33.1 | 74.0 | -40.9 | Peak |
| 2 | 1496.53 | 37.2 | 25.8 | 5.3 | 37.1 | 31.2 | 74.0 | -42.8 | Peak |
| 3 | 1816.04 | 36.3 | 25.4 | 6.0 | 37.4 | 30.3 | 74.0 | -43.7 | Peak |
| 4 | 2498.25 | 38.6 | 27.2 | 6.8 | 37.6 | 35.0 | 74.0 | -39.0 | Peak |
| 5 | 3239.42 | 36.5 | 28.6 | 7.8 | 37.4 | 35.5 | 74.0 | -38.5 | Peak |
| 6 | 5675.82 | 32.2 | 31.6 | 10.4 | 34.3 | 39.9 | 74.0 | -34.1 | Peak |

6. TEST SETUP PHOTOS OF THE EUT

Conducted Emissions (AC Mains)

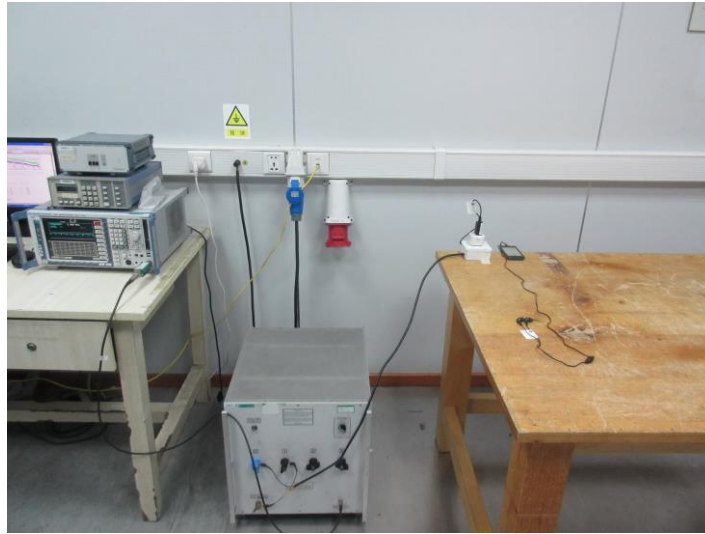

Radiated Emissions (30MHz-1GHz)



Radiated Emissions (Above 1GHz)



7. **EXTERNAL AND INTERNAL PHOTOS OF THE EUT**

Reference to the test report No.: TRE1810019201

-----End of Report-----