



TEST REPORT

Report Reference No...... : **CHEW2012013505** Report verification: 

Project No...... : **SHT2012030407EW**

FCC ID..... : **ZSW-30-075**

Applicant's name..... : **b mobile HK Limited**

Address..... : Flat 18; 14/F Block 1; Golden Industrial Building;16-26 Kwai Tak Street; Kwai Chung; New Territories; Hong Kong.

Manufacturer..... : b mobile HK Limited

Address..... : Flat 18; 14/F Block 1; Golden Industrial Building;16-26 Kwai Tak Street; Kwai Chung; New Territories; Hong Kong.

Test item description : **Mobile Phone**

Trade Mark : Bmobile

Model/Type reference..... : AX687

Listed Model(s) : AX687+, AX689

Standard : **47 CFR FCC Part 15 Subpart B**

Date of receipt of test sample..... : Dec. 09, 2020

Date of testing..... : Dec. 10, 2020- Dec. 21, 2020

Date of issue..... : Dec. 22, 2020

Result..... : **Pass**

Compiled by
 (position+printed name+signature)...: File administrators Silvia Li 

Supervised by
 (position+printed name+signature)...: Project Engineer Aaron Fang 

Approved by
 (position+printed name+signature)...: RF Manager Hans Hu 

Testing Laboratory Name : **Shenzhen Huatongwei International Inspection Co., Ltd.**

Address..... : 1/F, Bldg 3, Hongfa Hi-tech Industrial Park, Genyu Road, Tianliao, Gongming, Shenzhen, China

Shenzhen Huatongwei International Inspection Co., Ltd. All rights reserved.

This publication may be reproduced in whole or in part for non-commercial purposes as long as the Shenzhen Huatongwei International Inspection Co., Ltd. is acknowledged as copyright owner and source of the material. Shenzhen Huatongwei International Inspection Co., Ltd. takes no responsibility for and will not assume liability for damages resulting from the reader's interpretation of the reproduced material due to its placement and context.

The test report merely corresponds to the test sample.

Contents

1.	<u>TEST STANDARDS AND REPORT VERSION</u>	<u>3</u>
1.1.	Test Standards	3
1.2.	Report version information	3
2.	<u>TEST DESCRIPTION</u>	<u>4</u>
3.	<u>SUMMARY.....</u>	<u>5</u>
3.1.	Client Information	5
3.2.	Product Description	5
3.3.	EUT operation mode	5
3.4.	Configuration of Tested System	5
3.5.	Support unit used in test configuration	6
4.	<u>TEST ENVIRONMENT</u>	<u>7</u>
4.1.	Address of the test laboratory	7
4.2.	Test Facility	7
4.3.	Environmental conditions	8
4.4.	Statement of the measurement uncertainty	8
4.5.	Equipments Used during the Test	9
6.	<u>TEST CONDITIONS AND RESULTS</u>	<u>10</u>
6.1.	Conducted Emissions Test	10
6.2.	Radiated Emissions Test	13
7.	<u>TEST SETUP PHOTOS OF THE EUT</u>	<u>17</u>
8.	<u>EXTERNAL AND INTERNAL PHOTOS OF THE EUT</u>	<u>18</u>

1. TEST STANDARDS AND REPORT VERSION

1.1. Test Standards

The tests were performed according to following standards:

[47 CFR FCC Part 15 Subpart B](#) - Unintentional Radiators

[ANSI C63.4: 2014](#) – American National Standard for Methods of Measurement of Radio-Noise Emissions from Low-Voltage Electrical and Electronic Equipment in the Range of 9 kHz to 40GHz

1.2. Report version information

Revision No.	Date of issue	Description
N/A	2020-12-22	Add list models, update supplier of power IC,make difference test on Radiated Emissions Test, others are the same as report No. TRE1810027106

2. TEST DESCRIPTION

Test Item	Section in CFR 47	Result	Test Engineer
Conducted Emissions	15.107(a)	Pass	Tony Duan
Radiated Emissions	15.109(a)	Pass	Pan Xie

Note: The measurement uncertainty is not included in the test result.

3. SUMMARY

3.1. Client Information

Applicant:	b mobile HK Limited
Address:	Flat 18; 14/F Block 1; Golden Industrial Building;16-26 Kwai Tak Street; Kwai Chung; New Territories; Hong Kong.
Manufacturer:	b mobile HK Limited
Address:	Flat 18; 14/F Block 1; Golden Industrial Building;16-26 Kwai Tak Street; Kwai Chung; New Territories; Hong Kong.

3.2. Product Description

Name of EUT:	Mobile Phone
Trade Mark:	Bmobile
Model No.:	AX687
Listed Model(s)	AX687+, AX689
Power supply:	DC 3.7V
Adapter information:	Input:100-240Va.c. 50/60Hz 0.2A Output:5.0Vd.c. 500mA

3.3. EUT operation mode

Test mode	Describe
Camera recording mode	Keep the EUT in Camera recording status
Video Playing mode	Keep the EUT in Video Playing status
Data exchange mode	Keep the EUT in Data exchange with PC status
Video Playing mode	C2PC difference test

Pre-scan all of above modes. Only show Video Playing mode for radiated emission as C2PC test, and video playing mode for conducted emission, which is the worst case on the report.

3.4. Configuration of Tested System

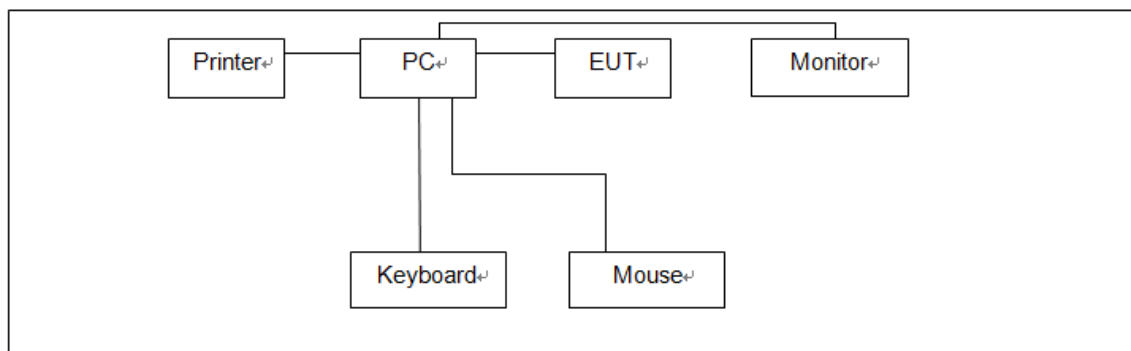

3.5. Support unit used in test configuration

Item	Equipment	Manufacturer	Model No.	FCC ID / FCC DoC	Data Cable	Power Cord
1	PC	DELL	OptiPlex 3020 MT	FCC DoC	N/A	Unshielded 1.8m
2	Monitor	DELL	E1912Hf	FCC DoC	N/A	Unshielded 1.8m
3	Keyboard	DELL	SK8115	FCC DoC	Unshielded, 1.5m	N/A
4	Mouse	DELL	MS111-T	FCC DoC	Unshielded, 1.5m	N/A
5	Printer	EPSON	L101	FCC DoC	N/A	Unshielded 1.8m

4. TEST ENVIRONMENT

4.1. Address of the test laboratory

Laboratory: Shenzhen Huatongwei International Inspection Co., Ltd.

Address: 1/F, Bldg 3, Hongfa Hi-tech Industrial Park, Genyu Road, Tianliao, Gongming, Shenzhen, China

Phone: 86-755-26748019 Fax: 86-755-26748089

4.2. Test Facility

The test facility is recognized, certified, or accredited by the following organizations:

CNAS-Lab Code: L1225

Shenzhen Huatongwei International Inspection Co., Ltd. has been assessed and proved to be in compliance with CNAS-CL01 Accreditation Criteria for Testing and Calibration Laboratories (identical to ISO/IEC17025: 2005 General Requirements) for the Competence of Testing and Calibration Laboratories.

A2LA-Lab Cert. No. 3902.01

Shenzhen Huatongwei International Inspection Co., Ltd. EMC Laboratory has been accredited by A2LA for technical competence in the field of electrical testing, and proved to be in compliance with ISO/IEC 17025: 2005 General Requirements for the Competence of Testing and Calibration Laboratories and any additional program requirements in the identified field of testing.

FCC-Registration No.: 762235

Shenzhen Huatongwei International Inspection Co., Ltd. EMC Laboratory has been registered and fully described in a report filed with the FCC (Federal Communications Commission). The acceptance letter from the FCC is maintained in our files. Registration 762235.

IC-Registration No.: 5377B-1

Two 3m Alternate Test Site of Shenzhen Huatongwei International Inspection Co., Ltd. has been registered by Certification and Engineering Bureau of Industry Canada for the performance of radiated measurements with Registration No. 5377B-1.

ACA

Shenzhen Huatongwei International Inspection Co., Ltd. EMC Laboratory can also perform testing for the Australian C-Tick mark as a result of our A2LA accreditation.

4.3. Environmental conditions

During the measurement the environmental conditions were within the listed ranges:

Temperature:	15~35°C
Relative Humidity:	30~60 %
Air Pressure:	950~1050mba

4.4. Statement of the measurement uncertainty

The data and results referenced in this document are true and accurate. The reader is cautioned that there may be errors within the calibration limits of the equipment and facilities. The measurement uncertainty was calculated for all measurements listed in this test report acc. to CISPR 16 - 4 „Specification for radio disturbance and immunity measuring apparatus and methods – Part 4: Uncertainty in EMC Measurements“ and is documented in the Shenzhen Huatongwei International Inspection Co., Ltd quality system acc. to DIN EN ISO/IEC 17025. Furthermore, component and process variability of devices similar to that tested may result in additional deviation. The manufacturer has the sole responsibility of continued compliance of the device.

Hereafter the best measurement capability for Shenzhen Huatongwei laboratory is reported:

Test	Range	Measurement Uncertainty	Notes
Radiated Emissions	30~1000MHz	4.28 dB	(1)
Radiated Emissions	1~18GHz	5.16 dB	(1)
Conducted Disturbance	0.15~30MHz	3.35 dB	(1)

(1) This uncertainty represents an expanded uncertainty expressed at approximately the 95% confidence level using a coverage factor of k=1.96.

4.5. Equipments Used during the Test

5. Conducted Emissions						
Item	Test Equipment	Manufacturer	Model No.	Serial No.	Last Cal. (mm-dd-yy)	Next Cal. (mm-dd-yy)
1	EMI Test Receiver	R&S	ESCI	101247	10/27/2018	10/26/2019
2	Artificial Mains	SCHWARZBECK	NNLK 8121	573	10/27/2018	10/26/2019
3	Pulse Limiter	R&S	ESH3-Z2	101488	10/27/2018	10/26/2019
4	RF Connection Cable	HUBER+SUHNER	EF400	N/A	11/14/2017	11/13/2019
5	Test Software	R&S	ES-K1	N/A	N/A	N/A
6	Temperature and Humidity Meter	MIAOXIN	TH10R	N/A	10/30/2018	10/29/2019

Radiated Emissions(Below 1GHz)						
Item	Test Equipment	Manufacturer	Model No.	Serial No.	Last Cal. (mm-dd-yy)	Next Cal. (mm-dd-yy)
1	Semi-Anechoic Chamber	Albatross projects	SAC-3m-02	C11121	2018/09/30	2021/09/29
2	EMI Test Receiver	R&S	ESCI	100900	2020/10/19	2021/10/18
3	Loop Antenna	R&S	HFH2-Z2	100020	2018/04/02	2021/04/02
4	Ultra-Broadband Antenna	SCHWARZBECK	VULB9163	546	2020/04/28	2023/04/27
5	Pre-amplifier	SCHWARZBECK	BBV 9742	N/A	2020/11/12	2021/11/11
6	RF Connection Cable	HUBER+SUHNER	N/A	N/A	2020/05/27	2021/05/26
7	RF Connection Cable	HUBER+SUHNER	SUCOFLEX104	501184/4	2020/05/27	2021/05/26
8	Test Software	R&S	ES-K1	N/A	N/A	N/A
9	Turntable	Maturo Germany	TT2.0-1T	N/A	N/A	N/A
10	Antenna Mast	Maturo Germany	TAM-4.0-P	N/A	N/A	N/A
11	Temperature and Humidity Meter	KEJIAN	KJ03	N/A	N/A	N/A

Radiated Emissions(Above 1GHz)						
Item	Test Equipment	Manufacturer	Model No.	Serial No.	Last Cal. (mm-dd-yy)	Next Cal. (mm-dd-yy)
1	Anechoic Chamber	Albatross projects	SAC-3m-01	C11121	09/30/2018	09/29/2021
2	Horn Antenna	SCHWARZBECK	9120D	1011	03/27/2017	03/26/2020
3	Preamplifier	BONN	BLWA0160-2M	1811887	11/14/2018	11/13/2019
4	Broadband Pre-amplifier	SCHWARZBECK	BBV 9718	9718-248	04/28/2018	04/27/2019
5	Spectrum Analyzer	R&S	FSP40	100597	10/27/2018	10/26/2019
6	RF Connection Cable	HUBER+SUHNER	RE-7-FL	N/A	11/15/2018	11/14/2019
7	RF Connection Cable	HUBER+SUHNER	RE-7-FH	N/A	11/15/2018	11/14/2019
8	Test Software	Audix	E3	N/A	N/A	N/A
9	Turntable	Maturo Germany	TT2.0-1T	N/A	N/A	N/A
10	Antenna Mast	Maturo Germany	CAM-4.0-P-12	N/A	N/A	N/A
11	Temperature and Humidity Meter	MINGLE	YH101	N/A	10/30/2018	10/29/2019

6. TEST CONDITIONS AND RESULTS

6.1. Conducted Emissions Test

LIMIT

FCC CFR Title 47 Part 15 Subpart B Section 15.107:

Frequency range (MHz)	Limit (dBuV)	
	Quasi-peak	Average
0.15-0.5	66 to 56*	56 to 46*
0.5-5	56	46
5-30	60	50

* Decreases with the logarithm of the frequency.

TEST CONFIGURATION

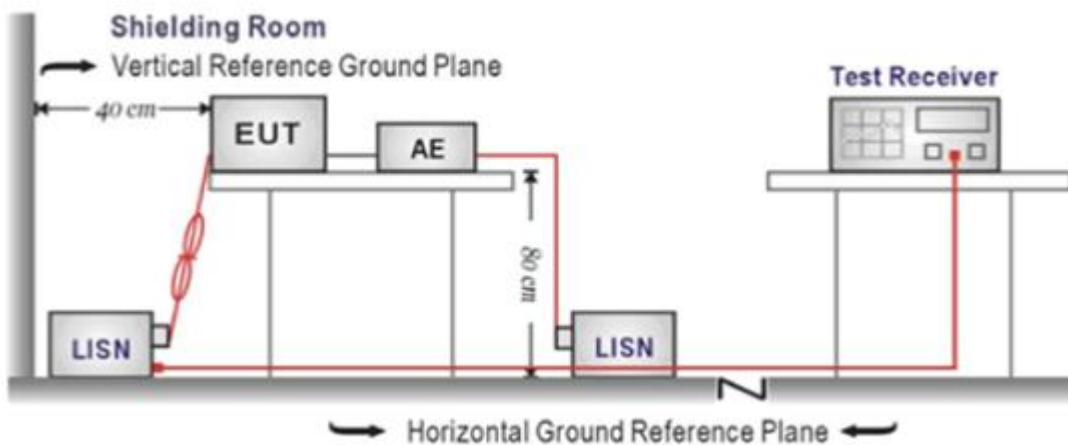

TEST PROCEDURE

1. The EUT was setup according to ANSI C63.4:2014
2. The EUT was placed on a platform of nominal size, 1 m by 1.5 m, raised 10 cm above the conducting ground plane. The vertical conducting plane was located 40 cm to the rear of the EUT. All other surfaces of EUT were at least 10 cm from any other grounded conducting surface.
3. The EUT and simulators are connected to the main power through a line impedance stabilization network (LISN). The LISN provides a 50ohm / 50uH coupling impedance for the measuring equipment.
4. The peripheral devices are also connected to the main power through a LISN. (Please refer to the block diagram of the test setup and photographs)
5. Each current-carrying conductor of the EUT power cord, except the ground (safety) conductor, was individually connected through a LISN to the input power source.
6. The excess length of the power cord between the EUT and the LISN receptacle were folded back and forth at the center of the lead to form a bundle not exceeding 40 cm in length.
7. Conducted emissions were investigated over the frequency range from 0.15MHz to 30MHz using a receiver bandwidth of 9 kHz.
8. During the above scans, the emissions were maximized by cable manipulation.

TEST MODE:

Please refer to the clause 3.3

TEST RESULTS

Passed Not Applicable

Test Line:

L

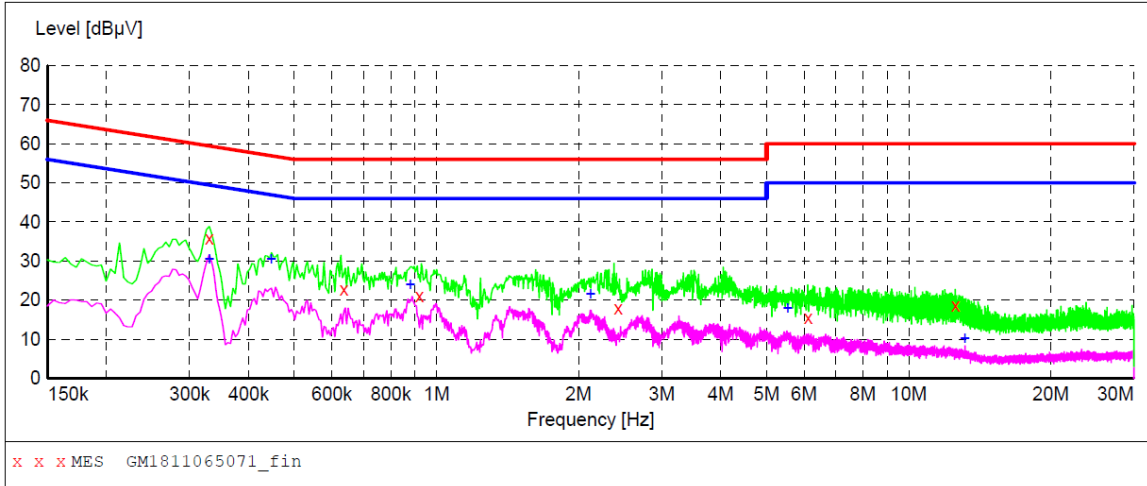

MEASUREMENT RESULT: "GM1811065071_fin"

11/6/2018 5:43PM

Frequency MHz	Level dBµV	Transd dB	Limit dBµV	Margin dB	Detector	Line	PE
0.330000	35.70	10.1	60	23.8	QP	L1	GND
0.636000	22.80	10.0	56	33.2	QP	L1	GND
0.919500	21.00	9.9	56	35.0	QP	L1	GND
2.422500	17.90	10.0	56	38.1	QP	L1	GND
6.126000	15.50	10.0	60	44.5	QP	L1	GND
12.552000	18.70	10.2	60	41.3	QP	L1	GND

MEASUREMENT RESULT: "GM1811065071_fin2"

11/6/2018 5:43PM

Frequency MHz	Level dBµV	Transd dB	Limit dBµV	Margin dB	Detector	Line	PE
0.330000	30.40	10.1	50	19.1	AV	L1	GND
0.447000	30.50	10.1	47	16.4	AV	L1	GND
0.879000	24.00	9.9	46	22.0	AV	L1	GND
2.121000	21.50	10.0	46	24.5	AV	L1	GND
5.545500	17.90	10.0	50	32.1	AV	L1	GND
13.155000	10.10	10.2	50	39.9	AV	L1	GND

Test Line:

N

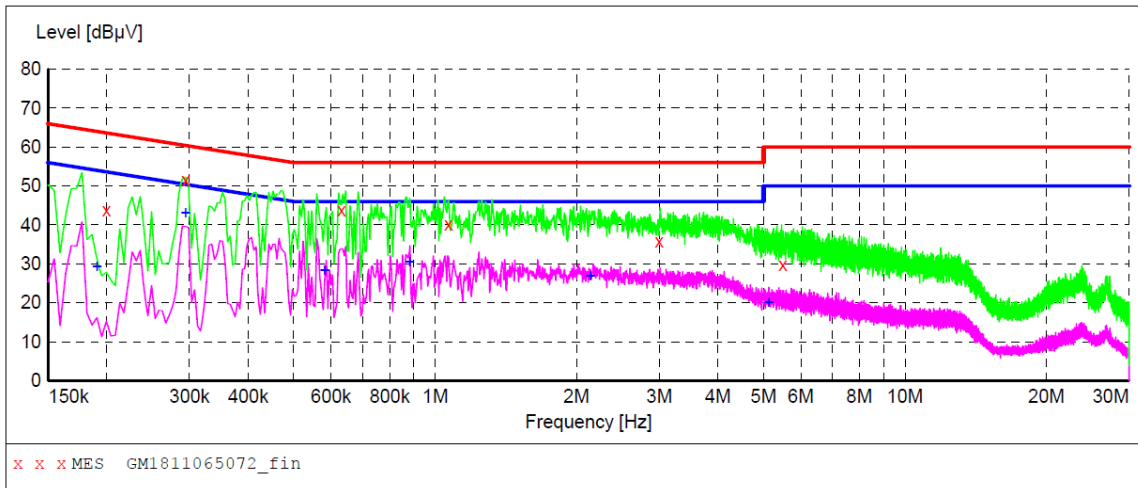

MEASUREMENT RESULT: "GM1811065072_fin"

11/6/2018 5:46PM

Frequency MHz	Level dBµV	Transd dB	Limit dBµV	Margin dB	Detector	Line	PE
0.199500	43.90	10.1	64	19.7	QP	N	GND
0.294000	51.50	10.2	60	8.9	QP	N	GND
0.631500	43.80	10.0	56	12.2	QP	N	GND
1.068000	40.20	10.0	56	15.8	QP	N	GND
2.994000	35.80	10.0	56	20.2	QP	N	GND
5.487000	29.80	10.0	60	30.2	QP	N	GND

MEASUREMENT RESULT: "GM1811065072_fin2"

11/6/2018 5:46PM

Frequency MHz	Level dBµV	Transd dB	Limit dBµV	Margin dB	Detector	Line	PE
0.190500	29.20	10.1	54	24.8	AV	N	GND
0.294000	43.10	10.2	50	7.3	AV	N	GND
0.582000	28.20	10.0	46	17.8	AV	N	GND
0.883500	30.60	9.9	46	15.4	AV	N	GND
2.139000	26.80	10.0	46	19.2	AV	N	GND
5.131500	20.10	10.0	50	29.9	AV	N	GND

6.2. Radiated Emissions Test

LIMIT

FCC CFR Title 47 Part 15 Subpart B Section 15.109

Frequency	Limit (dBuV/m @3m)	Value
30MHz-88MHz	40.00	Quasi-peak
88MHz-216MHz	43.50	Quasi-peak
216MHz-960MHz	46.00	Quasi-peak
960MHz-1GHz	54.00	Quasi-peak
Above 1GHz	54.00	Average
	74.00	Peak

TEST CONFIGURATION

➤ 30MHz ~ 1GHz

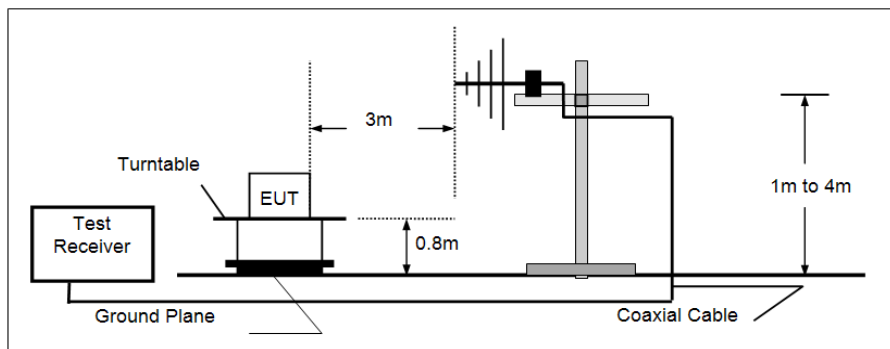

➤ Above 1GHz

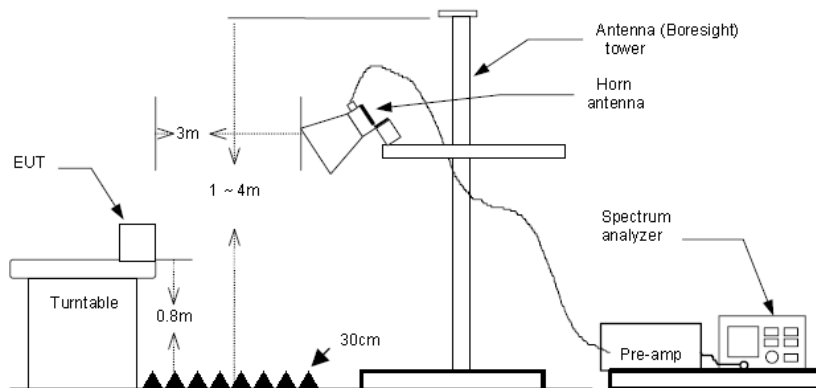

TEST PROCEDURE

1. The EUT was tested according to ANSI C63.4:2014.
2. The EUT is placed on a turn table which is 0.8 meter above ground.
3. The turn table is rotated 360 degrees to determine the position of the maximum emission level.
4. The EUT was positioned such that the distance from antenna to the EUT was 3 meters.
5. The antenna is scanned from 1 meter to 4 meters to find out the maximum emission level. This is repeated for both horizontal and vertical polarization of the antenna.
6. Use the following spectrum analyzer settings
 - (1) Span shall wide enough to fully capture the emission being measured;
 - (2) Below 1GHz,
 RBW=120KHz, VBW=300KHz, Sweep=auto, Detector function=peak, Trace=max hold;
 If the emission level of the EUT measured by the peak detector is 3 dB lower than the applicable limit, the peak emission level will be reported. Otherwise, the emission measurement will be repeated using the quasi-peak detector and reported.
 - (3) From 1GHz to 5th harmonic, RBW=1MHz, VBW=3MHz

TEST MODE:

Please refer to the clause 3.3

TEST RESULTS

Passed **Not Applicable**

Note: Final Level =Receiver Read level + Antenna Factor + Cable Loss – Preamplifier Factor

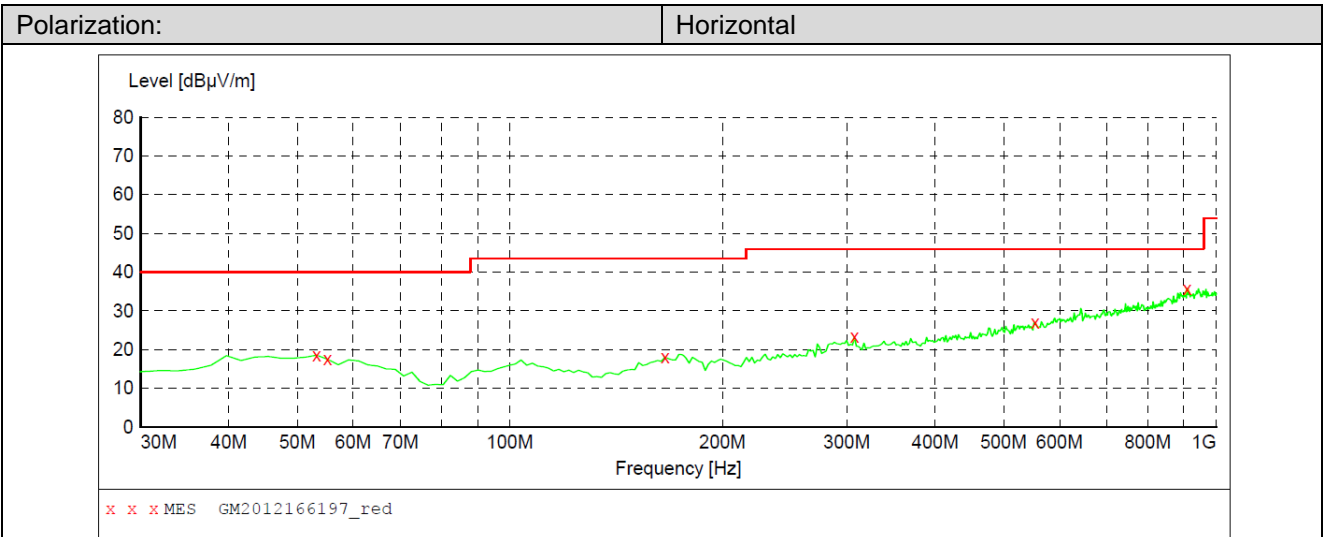

MEASUREMENT RESULT: "GM2012166197_red"

12/16/2020 2:52AM

Frequency MHz	Level dBuV/m	Transd dB	Limit dBuV/m	Margin dB	Det.	Height cm	Azimuth deg	Polarization
53.280000	18.50	-9.0	40.0	21.5	QP	100.0	0.00	HORIZONTAL
55.220000	17.50	-9.1	40.0	22.5	QP	100.0	45.00	HORIZONTAL
165.800000	18.00	-12.9	43.5	25.5	QP	100.0	71.00	HORIZONTAL
307.420000	23.30	-6.8	46.0	22.7	QP	100.0	242.00	HORIZONTAL
553.800000	27.10	0.0	46.0	18.9	QP	100.0	299.00	HORIZONTAL
908.820000	35.80	7.7	46.0	10.2	QP	100.0	253.00	HORIZONTAL

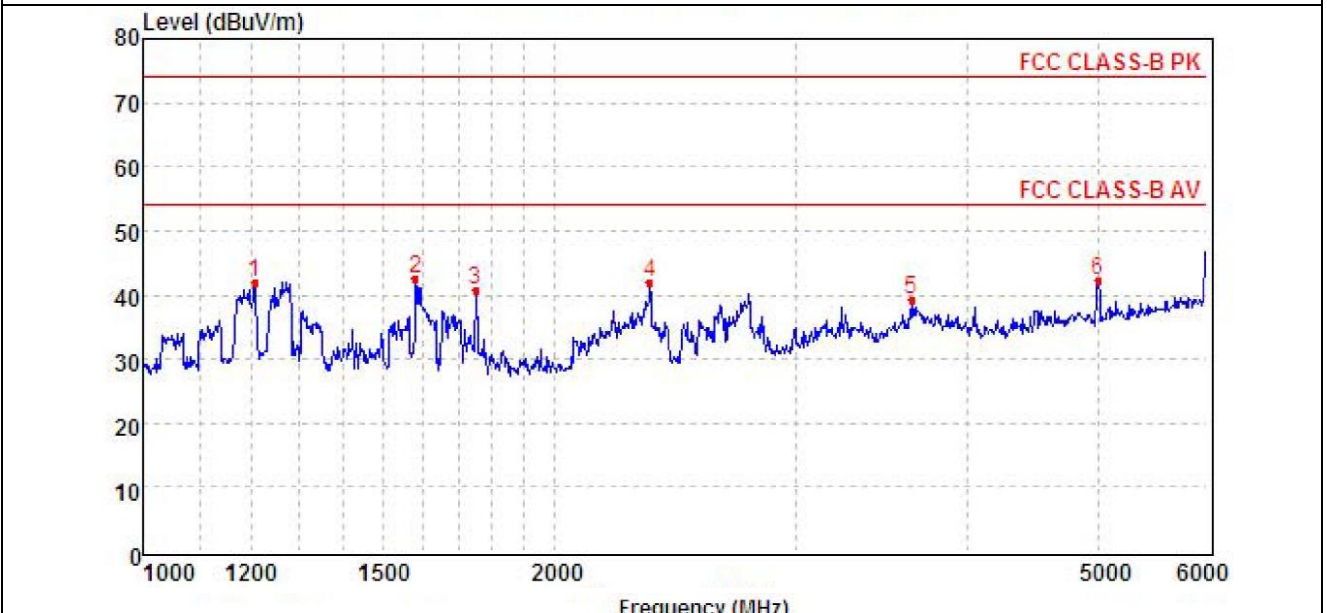

Mark	Frequency MHz	Reading dBuv/m	Antenna dB	Cable dB	Preamp dB	Level dBuv/m	Limit dBuv/m	Over limit	Remark
1	1207.00	48.2	26.3	4.7	37.2	42.0	74.0	-32.0	Peak
2	1582.00	49.0	25.1	5.5	37.2	42.4	74.0	-31.6	Peak
3	1752.11	46.8	25.3	5.9	37.4	40.6	74.0	-33.4	Peak
4	2346.39	45.1	27.9	6.7	37.6	42.1	74.0	-31.9	Peak
5	3646.07	38.7	29.3	8.3	37.0	39.3	74.0	-34.7	Peak
6	4997.81	36.4	31.5	9.7	35.4	42.2	74.0	-31.8	Peak

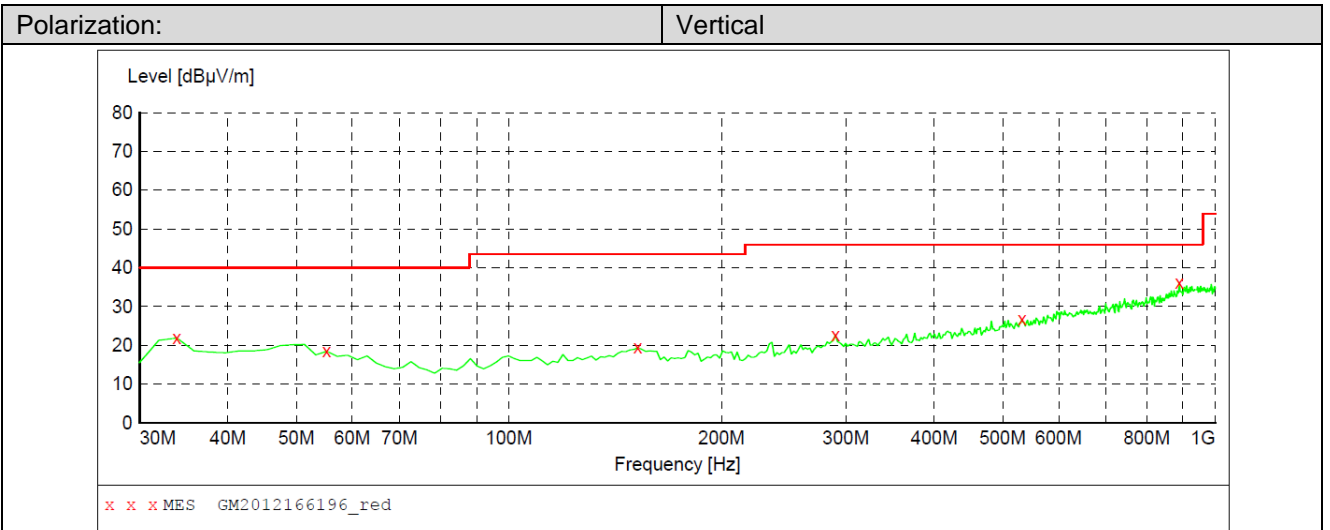

MEASUREMENT RESULT: "GM2012166196_red"

12/16/2020 2:49AM

Frequency MHz	Level dBuV/m	Transd dB	Limit dBuV/m	Margin dB	Det.	Height cm	Azimuth deg	Polarization
33.880000	21.90	-12.5	40.0	18.1	QP	100.0	229.00	VERTICAL
55.220000	18.50	-9.1	40.0	21.5	QP	100.0	33.00	VERTICAL
152.220000	19.40	-13.5	43.5	24.1	QP	100.0	24.00	VERTICAL
289.960000	22.70	-7.1	46.0	23.3	QP	100.0	252.00	VERTICAL
532.460000	26.70	-0.5	46.0	19.3	QP	100.0	68.00	VERTICAL
889.420000	36.30	7.3	46.0	9.7	QP	100.0	359.00	VERTICAL

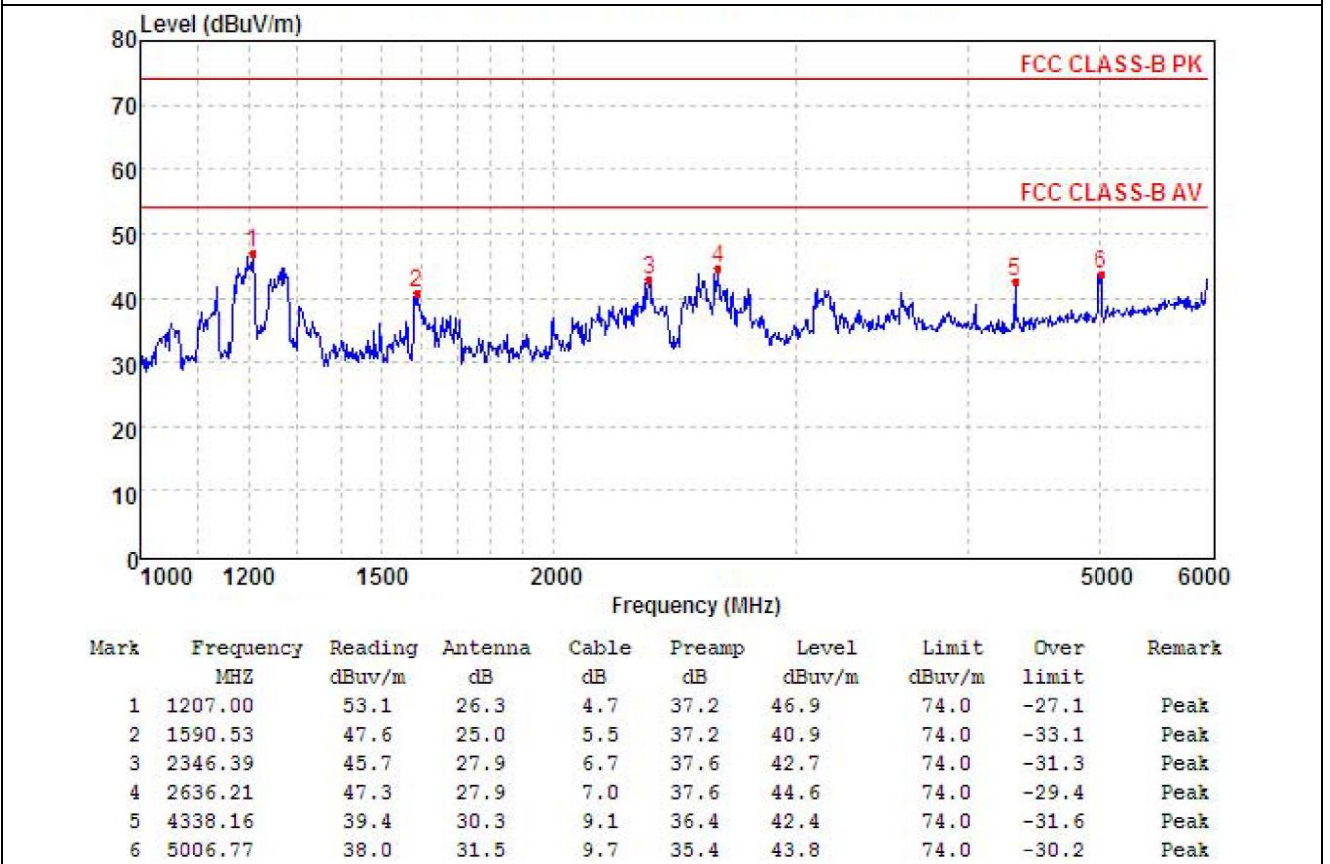

7. TEST SETUP PHOTOS OF THE EUT

Conducted Emissions (AC Mains)



Radiated Emissions (30MHz-1GHz)



Radiated Emissions (Above 1GHz)

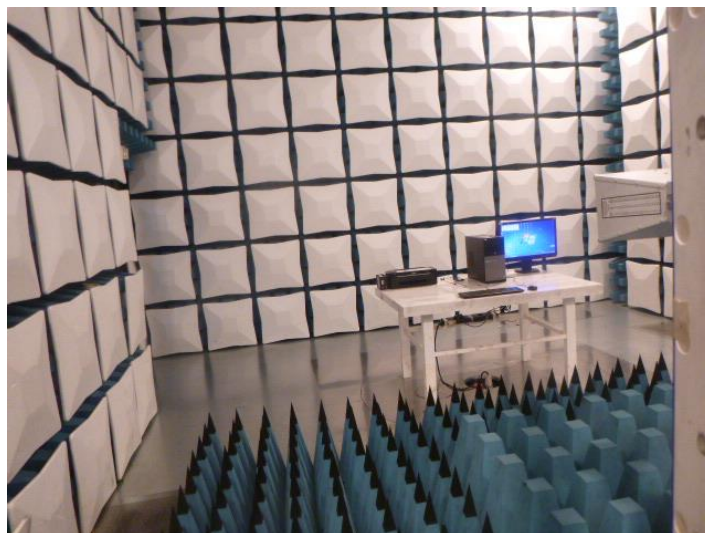



8. EXTERNAL AND INTERNAL PHOTOS OF THE EUT

Reference to the test report No.: CHTEW20120135

-----End of Report-----