

Test Report

Report Number:

F170032E2

Equipment under Test (EUT):

EASYSCAN Link

Applicant:

Gutermann Technology GmbH

Manufacturer:

Gutermann Technology GmbH



Deutsche
Akkreditierungsstelle
D-PL-17186-01-01
D-PL-17186-01-02
D-PL-17186-01-03

References

- [1] **ANSI C63.10: 2013** American National Standard of Procedures for Compliance Testing of Unlicensed Wireless Devices
- [2] **FCC CFR 47 Part 15** Radio Frequency Devices
- [3] **RSS-247 Issue 2 (February 2017)** Digital Transmission Systems (DTSs), Frequency Hopping Systems (FHSs) and Licence-Exempt Local Area Network (LE-LAN) Devices
- [4] **RSS-Gen Issue 4 (November 2014)** General Requirements for Compliance of Radio Apparatus

TEST RESULT

The requirements of the tests performed as shown in the overview (clause 4) were fulfilled by the equipment under test.

The complete test results are presented in the following.

Test engineer:	Thomas KÜHN		05/08/2017
	Name	Signature	Date
Authorized reviewer:	Michael DINTER		05/08/2017
	Name	Signature	Date

This test report is only valid in its original form.

Any reproduction of its contents in extracts without written permission of the accredited test laboratory PHOENIX TESTLAB GmbH is prohibited.

The test results herein refer only to the tested sample. PHOENIX TESTLAB GmbH is not responsible for any generalisations or conclusions drawn from these test results concerning further samples. Any modification of the tested samples is prohibited and leads to the invalidity of this test report. Each page necessarily contains the PHOENIX TESTLAB Logo and the TEST REPORT NUMBER.

This test report is valid in hardcopy form as well as in electronic form.

Contents:	Page
1 Identification.....	4
1.1 Applicant.....	4
1.2 Manufacturer.....	4
1.3 Test laboratory.....	4
1.4 EUT (Equipment Under Test).....	5
1.5 Technical data of equipment.....	5
1.6 Dates.....	6
2 Operational states.....	6
3 Additional information.....	7
4 Overview.....	7
5 Test results.....	8
5.1 Radiated emissions.....	8
5.1.1 Method of measurement (radiated emissions).....	8
5.1.2 Test results (radiated emissions).....	15
5.1.2.1 Preliminary radiated emission measurement.....	15
5.1.2.2 Final radiated emission measurement (1 GHz to 25 GHz).....	18
6 Test equipment and ancillaries used for tests.....	20
7 Report history.....	21
8 List of annexes.....	21

1 Identification

1.1 Applicant

Name:	Gutermann Technology GmbH
Address:	Gottlieb Daimler Straße 10 88214 Ravensburg
Country:	Germany
Name for contact purposes:	Mr. Hermann WAIBEL
Phone:	+49 751 35 90 16 - 83
Fax:	+49 751 35 90 16 - 99
eMail Address:	hermann.waibel@gutermann-water.com
Applicant represented during the test by the following person:	Mr. Hermann WAIBEL, Mr. Stefan LANG

1.2 Manufacturer

Name:	Gutermann Technology GmbH
Address:	Gottlieb Daimler Straße 10 88214 Ravensburg
Country:	Germany
Name for contact purposes:	Mr. Hermann WAIBEL
Phone:	+49 751 35 90 16 - 83
Fax:	+49 751 35 90 16 - 99
eMail Address:	hermann.waibel@gutermann-water.com
Manufacturer represented during the test by the following person:	Mr. Hermann WAIBEL, Mr. Stefan LANG

1.3 Test laboratory

The tests were carried out at: **PHOENIX TESTLAB GmbH**
Königswinkel 10
32825 Blomberg
Germany

accredited by Deutsche Akkreditierungsstelle GmbH (DAkKS) in compliance with DIN EN ISO/IEC 17025 under Reg. No. D-PL-17186-01-02, FCC Test Firm Accreditation with the registration number 469623, designation number DE0004 and Industry Canada Test site registration SITE# IC3469A-1.

1.4 EUT (Equipment Under Test)

Test object: *	Wireless transceiver for data collection
(PMN): *	EASYSCAN Link
Modelname / HVIN: *	GELK501
FCC ID:*	ZSSESC915A and X3ZBTMOD5
IC: *	9789A-ESC915A and 8828A-MOD5
Serial number: *	3500003

* declared by the applicant.

1.5 Technical data of equipment

Bluetooth part (BT7000)

Antenna type: *	Internal PCB antenna
Antenna gain: *	2.1 dBi
Max. output power: *	-1.4 dBm
Type of modulation: *	GFSK (1 Mbps), p/4 DQPSK (2 Mbps), 8DPSK (3 Mbps)
Operating frequency range:*	2400 – 2483.5 MHz
Number of channels: *	79
Temperature range EUT: *	-30 °C to +70 °C

* declared by the applicant.

915 MHz transceiver part

Channel 0	RX:	904.000 MHz	TX:	904.000 MHz
Channel 24	RX:	911.200 MHz	TX:	911.200 MHz
Channel 49	RX:	918.700 MHz	TX:	918.700 MHz

Rated RF output power: *	16 dBm					
Antenna type: *	Integral					
Antenna gain: *	-0.7 dBi					
Antenna connector: *	No					
Adaptive frequency agility: *	No					
Modulation: *	FHSS (GFSK)					
Supply Voltage: *	$U_{nom} =$	3.3 V DC	$U_{min} =$	3.7 V DC	$U_{max} =$	4.1 V DC
Temperature range: *	0 °C to +50 °C					

* declared by the applicant.

The following external I/O cables were used:

Identification	Connector		Length *
	EUT	Ancillary	
DC power	USB 2.0-micro-B plug	-	2 m
-	-	-	-
-	-	-	-
-	-	-	-

*: Length during the test if no other specified.

1.6 Dates

Date of receipt of test sample:	03/08/2017
Start of test:	03/09/2017
End of test:	03/09/2017

2 Operational states

Object of this test report is to find out if unwanted emissions caused by using two radio transmission technologies at the same time in the same device. Therefore the and proprietary 915 MHz transceiver was set to transmit at a fixed frequency and the Bluetooth transmitter to transmit with normal hopping mode (because no test mode was available to set the transmitter to a fixed operation frequency).

The operation mode of the 915 MHz transceiver could be adjusted via Bluetooth with a test-software by the applicant. After adjusting the 915 MHz operation mode, a Bluetooth link to a laptop PC was established and a data from the EUT to the PC was initiated.

All radiated measurements were carried out with a connection to an external 5 V DC power supply (buffering the internal battery), because preliminary measurements has shown, that the use of an external power supply causes higher emissions than the use of the internal battery without any connection to an external power supply.

Physical boundaries of the Equipment Under Test

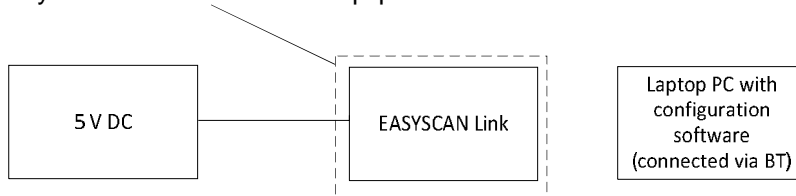

The following test modes were adjusted during the tests:

Operation mode	Description of the operation mode	Modulation
1	Transmission at Ch. 41 (915.15 MHz)	4GFSK
	Transmission at Bluetooth Ch. 41 (2441 MHz)	8DPSK

3 Additional information

In this test report only the simultaneous transmission measurement is described. The Bluetooth part and the 915 MHz part of the system are already tested.

The EUT was not labelled with an IC or FCC ID during the tests.

This report does not include an Annex with internal photos of the EUT. Please refer to test report F170032E1 of PHOENIX TESTLAB GmbH or the 915 MHz part of the EUT and 1506159 001 of TÜV Rheinland Co. Ltd. for the Bluetooth part of the EUT to get more detailed information.

4 Overview

Application	Frequency range [MHz]	FCC 47 CFR Part 15 section [2]	RSS 247, Issue 2 [3] or RSS-Gen, Issue 4 [4]	Status	Refer page
Radiated emissions (transmitter)	1000 - 25,000	15.247 (d) 15.205 (a) 15.209 (a)	5.5 [3] 8.9 [4]	Passed	8 et seq.

5 Test results

5.1 Radiated emissions

5.1.1 Method of measurement (radiated emissions)

The radiated emission measurement is subdivided into five stages.

- A preliminary measurement carried out in a fully anechoic chamber with a fixed antenna height in the frequency range 9 kHz to 1 GHz.
- A final measurement carried out on an outdoor test side without reflecting ground plane and a fixed antenna height in the frequency range 9 kHz to 30 MHz.
- A final measurement carried out on an open area test side with reflecting ground plane and various antenna heights in the frequency range 30 MHz to 1 GHz.
- A preliminary measurement carried out in a fully anechoic chamber with a variable antenna distance and height in the frequency range 1 GHz to 25 / 40 GHz.
- A final measurement carried out in a fully anechoic chamber with a fixed antenna height in the frequency range 1 GHz to 40 GHz.

Preliminary measurement (9 kHz to 30 MHz):

In the first stage a preliminary measurement will be performed in a shielded room with a measuring distance of 3 meters. Table-top devices will set up on a non-conducting support with a size of 1 m by 1.5 m and a height of 80 cm. Floor-standing devices will be placed directly on the turntable/ground plane. The set up of the Equipment under test will be in accordance to [1].

The frequency range 9 kHz to 30 MHz will be monitored with a spectrum analyser while the system and its cables will be manipulated to find out the configuration with the maximum emission levels if applicable. The EMI Receiver will be set to MAX Hold mode. The EUT and the measuring antenna will be rotated around their vertical axis to found the maximum emissions.

The resolution bandwidth of the spectrum analyser will be set to the following values:

Frequency range	Resolution bandwidth
9 kHz to 150 kHz	200 Hz
150 kHz to 30 MHz	10 kHz

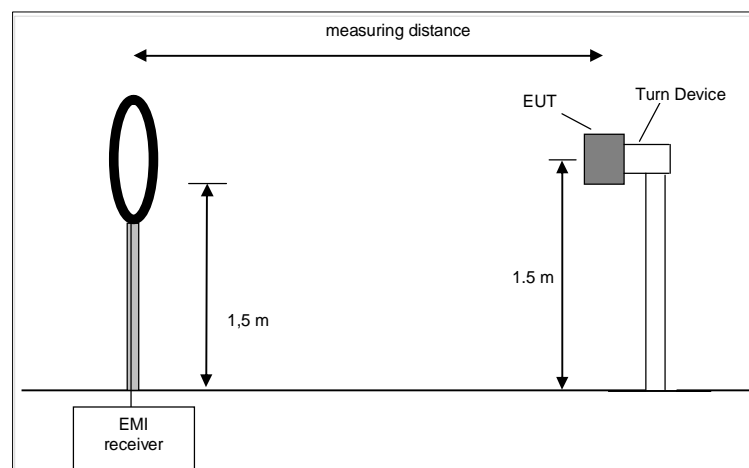

Preliminary measurement procedure:

Prescans were performed in the frequency range 9 kHz to 150 kHz and 150 kHz to 30 MHz.

The following procedure will be used:

- 1) Monitor the frequency range at horizontal polarisation and a EUT azimuth of 0 °.
- 2) Manipulate the system cables within the range to produce the maximum level of emission.
- 3) Rotate the EUT by 360 ° to maximize the detected signals.
- 4) Make a hardcopy of the spectrum.
- 5) Measure the frequencies of highest detected emission with a lower span and resolution bandwidth to increase the accuracy and note the frequency value.
- 6) Repeat steps 1) to 5) with the other orthogonal axes of the EUT (because of EUT is a module and might be used in a handheld equipment application).
- 7) Rotate the measuring antenna and repeat steps 1) to 5).

Final measurement (9 kHz to 30 MHz):

In the second stage a final measurement will be performed on an open area test site with no conducting ground plane in a measuring distances of 3 m, 10 m and 30 m. In the case where larger measuring distances are required the results will be extrapolated based on the values measured on the closer distances according to Section 15.31 (f) (2) [2]. The final measurement will be performed with a EMI Receiver set to Quasi Peak detector except for the frequency bands 9 kHz to 90 kHz and 110 kHz to 490 kHz where an average detector will be used according Section 15.209 (d) [2].

On the frequencies, which were detected during the preliminary measurements, the final measurement will be performed while rotating the EUT and the measuring antenna in the range of 0 ° to 360 ° around their vertical axis until the maximum value is found.

The resolution bandwidth of the EMI Receiver will be set to the following values:

Frequency range	Resolution bandwidth
9 kHz to 150 kHz	200 Hz
150 kHz to 30 MHz	9 kHz

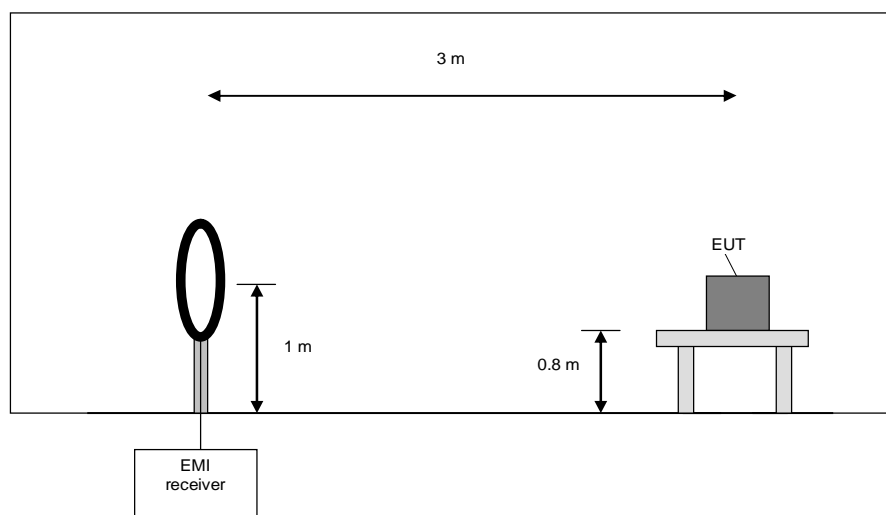

Final measurement procedure:

The following procedure will be used:

- 1) Monitor the frequency range with the measuring antenna at vertical orientation parallel to the EUT at an azimuth of 0 °.
- 2) Rotate the EUT by 360 ° to maximize the detected signals and note the azimuth and orientation.
- 3) Rotate the measuring antenna to find the maximum and note the value.
- 4) Rotate the measuring antenna and repeat steps 1) to 3) until the maximum value is found.
- 5) Repeat steps 1) to 4) with the other orthogonal axes of the EUT (if the EUT is a module and might be used in a handheld equipment application).

Preliminary measurement (30 MHz to 1 GHz)

In the first stage a preliminary measurement will be performed in a fully anechoic chamber with a measuring distance of 3 meter. Table top devices will set up on a non-conducting turn device on the height of 1.5 m. Floor-standing devices will be placed directly on the turntable/ground plane. The set up of the Equipment under test will be in accordance to [1].

The frequency range 30 MHz to 1 GHz will be measured with an EMI Receiver set to MAX Hold mode and a resolution bandwidth of 100 kHz. The measurement will be performed in horizontal and vertical polarisation of the measuring antenna and while rotating the EUT in its vertical axis in the range of 0 ° to 360 °. This measurement is repeated after raising the EUT in 30 ° steps according 6.6.5.4 in [1].

The resolution bandwidth of the EMI Receiver will be set to the following values:

Frequency range	Resolution bandwidth
30 MHz to 230 MHz	100 kHz
230 MHz to 1 GHz	100 kHz

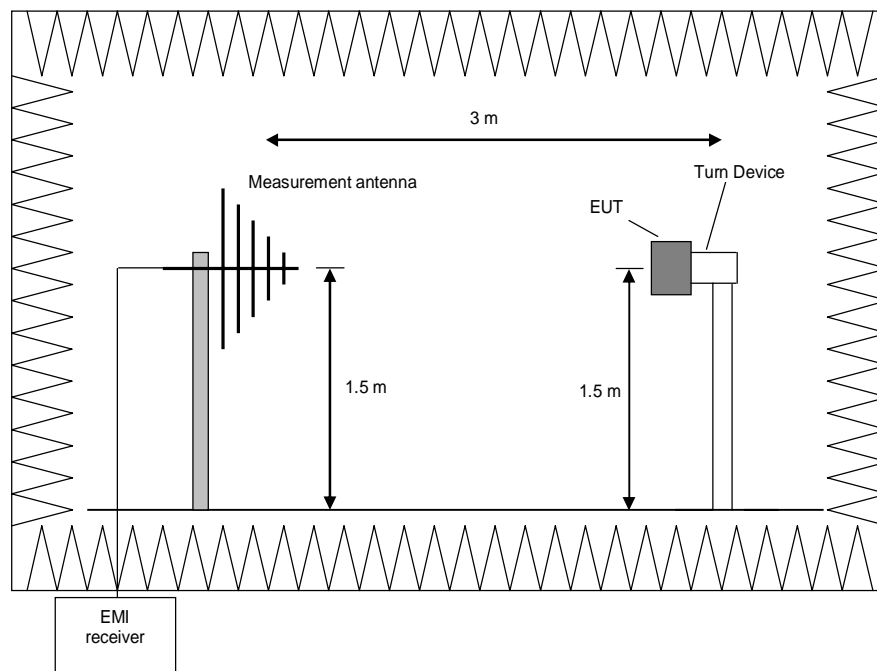

Procedure preliminary measurement:

Prescans were performed in the frequency range 30 MHz to 230 MHz and 230 MHz to 1 GHz.
The following procedure will be used:

1. Monitor the frequency range at horizontal polarisation and a EUT azimuth of 0 °.
2. Manipulate the system cables within the range to produce the maximum level of emission.
3. Rotate the EUT by 360 ° to maximize the detected signals.
4. Repeat 1) to 3) with the vertical polarisation of the measuring antenna.
5. Make a hardcopy of the spectrum.
6. Repeat 1) to 5) with the EUT raised by an angle of 30 ° (60 °, 90 °, 120 ° and 150 °) according to 6.6.5.4 in [1].
7. Measure the frequency of the detected emissions with a lower span and resolution bandwidth to increase the accuracy and note the frequency value.

Final measurement (30 MHz to 1 GHz)

A final measurement on an open area test site will be performed on selected frequencies found in the preliminary measurement. During this test the EUT will be rotated in the range of 0 ° to 360 °, the measuring antenna will be set to horizontal and vertical polarisation and raised and lowered in the range from 1 m to 4 m to find the maximum level of emissions.

The resolution bandwidth of the EMI Receiver will be set to the following values:

Frequency range	Resolution bandwidth
30 MHz to 1 GHz	120 kHz

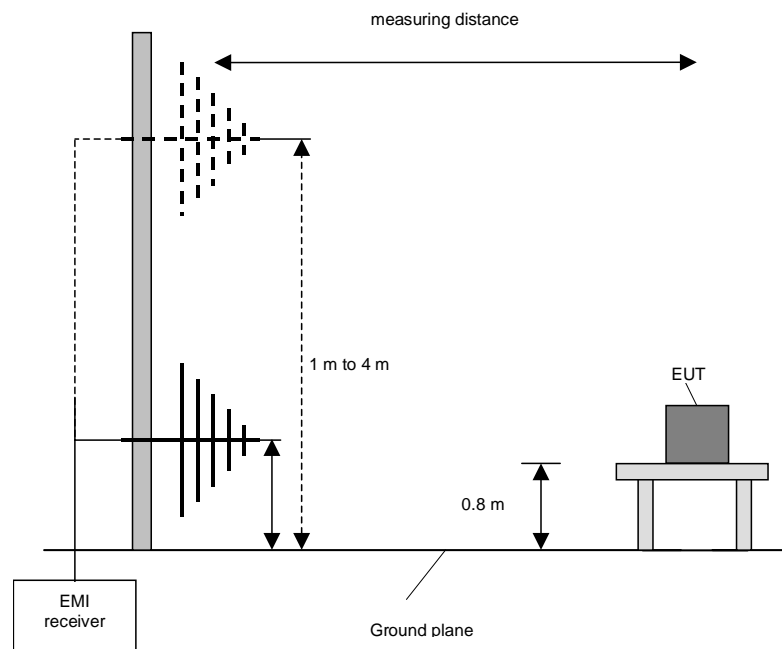

Procedure final measurement:

The following procedure will be used:

- 1) Measure on the selected frequencies at an antenna height of 1 m and a EUT azimuth of 23 °.
- 2) Move the antenna from 1 m to 4 m and note the maximum value at each frequency.
- 3) Rotate the EUT by 45 ° and repeat 2) until an azimuth of 337 ° is reached.
- 4) Repeat 1) to 3) for the other orthogonal antenna polarization.
- 5) Move the antenna and the turntable to the position where the maximum value is detected.
- 6) Measure while moving the antenna slowly +/- 1 m.
- 7) Set the antenna to the position where the maximum value is found.
- 8) Measure while moving the turntable +/- 45 °.
- 9) Set the turntable to the azimuth where the maximum value is found.
- 10) Measure with Final detector (QP and AV) and note the value.
- 11) Repeat 5) to 10) for each frequency.
- 12) Repeat 1) to 11) for each orthogonal axes of the EUT (because of EUT is a module and might be used in a handheld equipment application).

Preliminary and final measurement (1 GHz to 40 GHz)

This measurement will be performed in a fully anechoic chamber. Table top devices will set up on a non-conducting turn device on the height of 1.5 m. The set-up of the Equipment under test will be in accordance to [1].

Preliminary measurement (1 GHz to 40 GHz)

The frequency range will be divided into different sub ranges depending of the frequency range of the used horn antenna. The spectrum analyser set to MAX Hold mode and a resolution bandwidth of 100 kHz. The measurement will be performed in horizontal and vertical polarisation of the measuring antenna and while rotating the EUT in its vertical axis in the range of 0 ° to 360 °. This measurement is repeated after raising the EUT in 30 ° steps according 6.6.5.4 in [1].

The resolution bandwidth of the EMI Receiver will be set to the following values:

Frequency range	Resolution bandwidth
1 GHz to 4 GHz	100 kHz
4 GHz to 12 GHz	100 kHz
12 GHz to 18 GHz	100 kHz
18 GHz to 25 / 26.5 GHz	100 kHz
26.5 GHz to 40 GHz	100 kHz

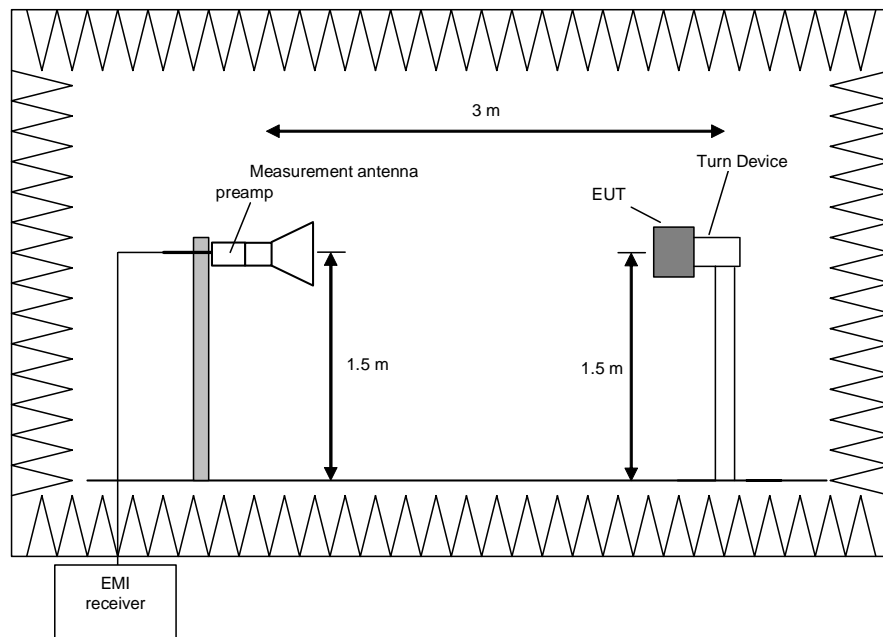

Procedure preliminary measurement:

Prescans were performed in the frequency range 1 to 40 GHz.

The following procedure will be used:

1. Monitor the frequency range at horizontal polarisation and a EUT azimuth of 0 °.
2. Rotate the EUT by 360° to maximize the detected signals.
3. Repeat 1) to 2) with the vertical polarisation of the measuring antenna.
4. Make a hardcopy of the spectrum.
5. Repeat 1) to 4) with the EUT raised by an angle of 30° (60°, 90°, 120° and 150°) according to 6.6.5.4 in [1].
6. Measure the frequency of the detected emissions with a lower span and resolution bandwidth to increase the accuracy and note the frequency value.
7. The measurement antenna polarisation, with the according EUT position (Turntable and Turn device) which produces the highest emission for each frequency will be used for the final measurement. The six closest values to the applicable limit will be used for the final measurement.

Final measurement (1 GHz to 40 GHz)

The frequency range will be divided into different sub ranges depending of the frequency range of the used horn antenna. The EMI Receiver set to peak and average mode and a resolution bandwidth of 1 MHz. The measurement will be performed by rotating the turntable through 0 to 360° in the worst-case EUT orientation which was obtained during the preliminary measurements.

The resolution bandwidth of the EMI Receiver will be set to the following values:

Frequency range	Resolution bandwidth
1 GHz to 4 GHz	1 MHz
4 GHz to 12 GHz	1 MHz
12 GHz to 18 GHz	1 MHz
18 GHz to 25 / 26.5 GHz	1 MHz
26.5 GHz to 40 GHz	1 MHz

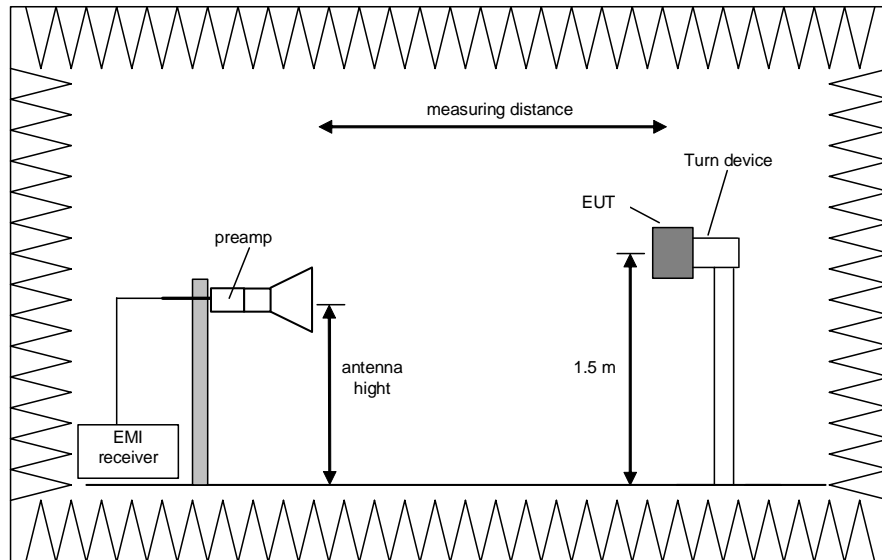

Procedure of measurement:

The measurements were performed in the frequency ranges 1 GHz to 4 GHz, 4 GHz to 12 GHz, 12 GHz to 18 GHz, 18 GHz to 25 /26.5 GHz and 26.5 GHz to 40 GHz.

The following procedure will be used:

- 1) Set the turntable and the turn device to obtain the worst-case emission for the first frequency identified in the preliminary measurements.
- 2) Set the measurement antenna polarisation to the orientation with the highest emission for the first frequency identified in the preliminary measurements.
- 3) Set the spectrum analyser to EMI mode with peak and average detector activated.
- 4) Rotate the turntable from 0° to 360° to find the EUT angle that produces the highest emissions.
- 5) Note the highest displayed peak and average values
- 6) Repeat the steps 1) to 5) for each frequency detected during the preliminary measurements.

5.1.2 Test results (radiated emissions)

5.1.2.1 Preliminary radiated emission measurement

Ambient temperature	22 °C	Relative humidity	33 %
---------------------	-------	-------------------	------

Position of EUT:	The EUT was set-up on the positioner at a height of 1.5 m. The distance between EUT and antenna was 3 m.
Cable guide:	For detail information of test set-up and the cable guide refer to the pictures in annex A of this test report.
Test record:	All results are shown in the following.
Supply voltage:	During all measurements the EUT was supplied 3.3 V DC by the internal battery, which was buffered by an external power supply with 5 V DC.
Frequency range:	The preliminary measurement was carried out in the frequency range 1 GHz to 25 GHz.

Transmitter operates at the lower end of the assigned frequency band (operation mode 1)

Spurious emissions from 1 GHz to 4 GHz (operation mode 1):

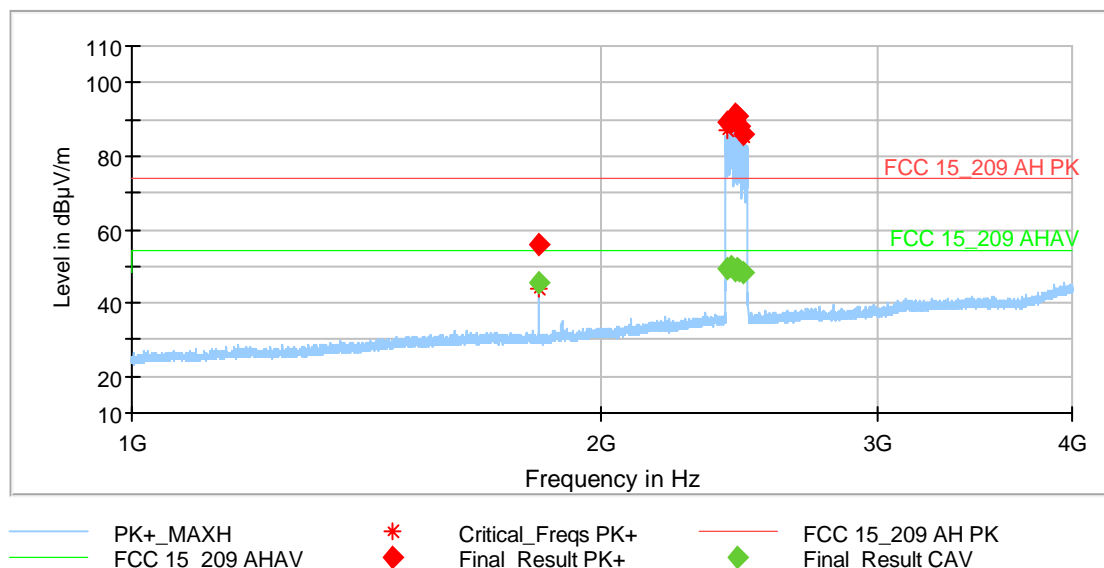

Spurious emissions from 4 GHz to 12 GHz (operation mode 1):

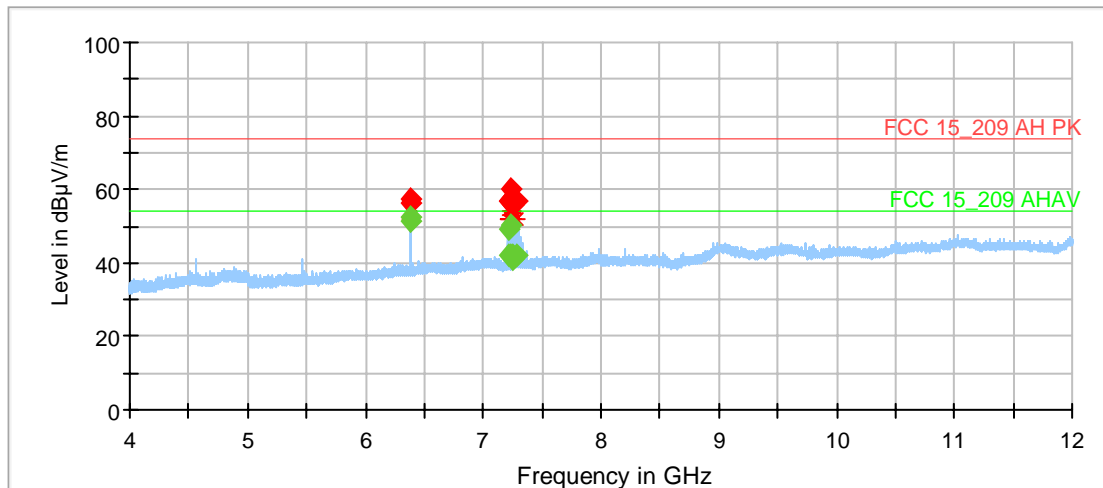

— Preview Result 1-PK+ * Critical_Freqs PK+ — FCC 15_209 AH PK
— FCC 15_209 AHAV ◆ Final_Result PK+ ◆ Final_Result AVG

Spurious emissions from 12 GHz to 18 GHz (operation mode 1):

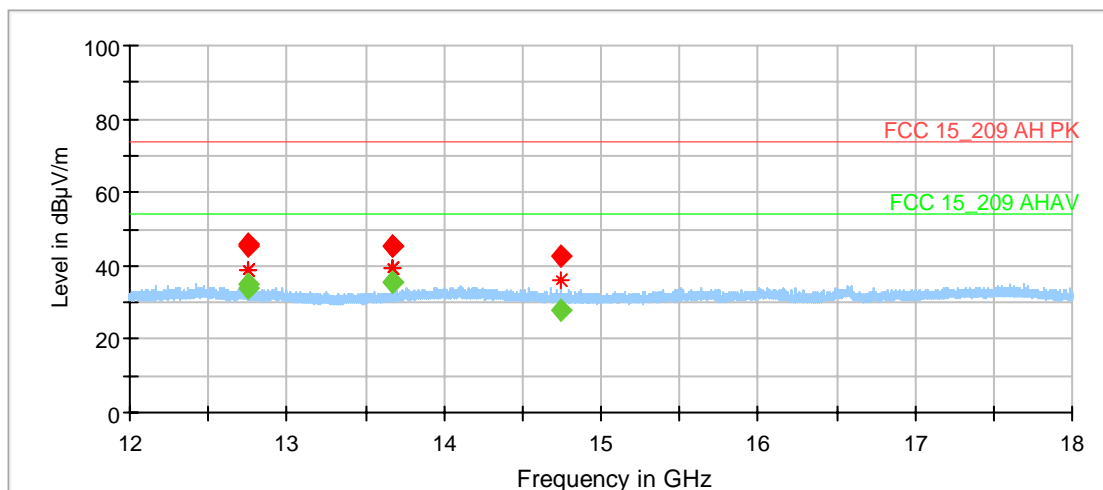

— Preview Result 1-PK+ * Critical_Freqs PK+ — FCC 15_209 AH PK
— FCC 15_209 AHAV ◆ Final_Result PK+ ◆ Final_Result CAV

Spurious emissions from 18 GHz to 25 GHz (operation mode 1):

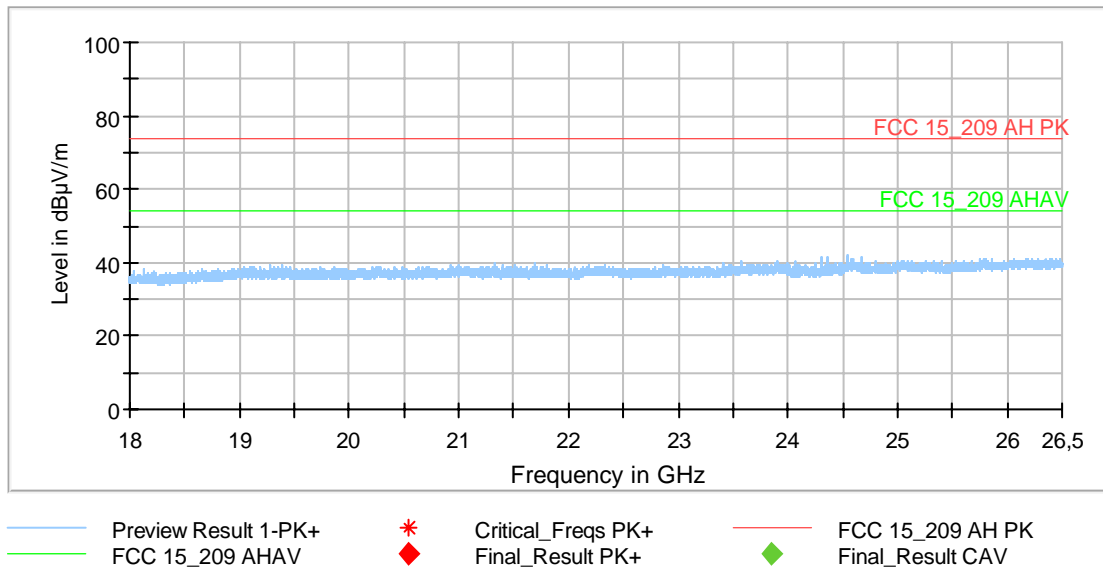

The following frequency was found inside the restricted bands during the preliminary radiated emission test:

- 12655.700 MHz.

The following frequencies were found outside the restricted bands during the preliminary radiated emission test:

- 1808.000 MHz and 6327.700 MHz.

These frequencies have to be measured in a final measurement. The results were presented in the following.

Test equipment used (see chapter 6):

1 - 17

5.1.2.2 Final radiated emission measurement (1 GHz to 25 GHz)

Ambient temperature	22 °C	Relative humidity	33 %
---------------------	-------	-------------------	------

- Position of EUT: The EUT was set-up on the positioner at a height of 1.5 m. The distance between EUT and antenna was 3 m.
- Cable guide: For detail information of test set-up and the cable guide refer to the pictures in annex A of this test report.
- Test record: All results are shown in the following.
- Supply voltage: During all measurements the EUT was supplied 3.3 V DC by the internal battery, which was buffered by an external power supply with 5 V DC.
- Resolution bandwidth: For all measurements a resolution bandwidth of 1 MHz was used.
- Test results: The test results were calculated with the following formula:

$$\text{Result [dB}\mu\text{V/m]} = \text{reading [dB}\mu\text{V]} + \text{cable loss [dB]} + \text{antenna factor [dB/m]} - \text{preamp [dB]}$$

Operation mode 1

Result measured with the peak detector:

Frequency MHz	Result dB μ V/m	Limit dB μ V/m	Margin dB	Readings dB μ V	Antenna factor 1/m	Preamp dB	Cable loss dB	Height cm	Pol.	Restr. Band
1822.400	55.8	74.0	18.17	52.6	26.7	26.1	2.6	150	Hor.	No
2440.000	90.7	Carrier	-	85.4	28.4	26.1	3.0	150	Vert.	No
6378.500	57.2	74.0	16.82	38.4	37.8	24.2	5.2	150	Vert.	No
7229.400	60.4	74.0	13.62	40.5	38.9	24.5	5.5	150	Hor.	No
12757.100	45.9	74.0	28.13	35.5	33.6	26.4	3.2	150	Hor.	No
13668.400	45.5	74.0	28.46	35.0	33.6	26.5	3.4	150	Hor.	No
14746.900	42.5	74.0	31.51	32.1	33.7	26.8	3.5	150	Vert.	No
Measurement uncertainty							+2.2 dB / -3.6 dB			

Result measured with the average detector:

Frequency MHz	Result dB μ V/m	Limit dB μ V/m	Margin dB	Readings dB μ V	Antenna factor 1/m	Preamp dB	Cable loss dB	Height cm	Pol.	Restr. Band
1822.400	45.4	54.0	8.6	42.2	26.7	26.1	2.6	150	Hor.	No
2440.000	49.6	Carrier	-	44.3	28.4	26.1	3.0	150	Vert.	No
6378.500	52.5	54.0	1.5	33.7	37.8	24.2	5.2	150	Vert.	No
7230.400	41.9	54.0	12.1	21.9	38.9	24.4	5.5	150	Hor.	No
12757.100	35.1	54.0	18.9	24.7	33.6	26.4	3.2	150	Hor.	No
13668.400	35.7	54.0	18.3	25.2	33.6	26.5	3.4	150	Hor.	No
14746.900	28.0	54.0	26.0	17.6	33.7	26.8	3.5	150	Vert.	No
Measurement uncertainty							+2.2 dB / -3.6 dB			

Test: Passed

Test equipment used (see chapter 6):

1 - 17

6 Test equipment and ancillaries used for tests

No.	Test equipment	Type	Manufacturer	Serial No.	PM. No.	Cal. Date	Cal. due
1	Fully anechoic chamber M20	-	Albatross Projects	B83107-E2439-T232	480303	Weekly verification (system cal.)	
2	Spectrum analyser	FSW	Rohde & Schwarz	100586	481720	02/24/2016	02/2018
3	Controller	MCU	Maturo	MCU/043/971107	480832	-	-
4	Turntable	DS420HE	Deisel	420/620/80	480315	-	-
5	Antenna support	AS615P	Deisel	615/310	480187	-	-
6	Antenna	HL50	Rohde & Schwarz	100438	481170	08/27/2014	08/2017
7	RF-cable No. 3	Sucoflex 106B	Suhner	0563/6B	480670	Weekly verification (system cal.)	
8	RF-cable No. 40	Sucoflex 106B	Suhner	0708/6B	481330	Weekly verification (system cal.)	
9	Preamplifier	JS3-00101200-23-5A	Miteq	681851	480337	Six month verification (system cal.)	
10	Turn device	TDF 1.5- 10Kg	Maturo	15920215	482034	-	-
11	High Pass Filter	WHJS1000C11 /60EF	Wainwright Instruments GmbH	1	480413	Weekly verification (system cal.)	
12	High Pass Filter	WHKX4.0/18G-8SS	Wainwright Instruments GmbH	1	480587	Weekly verification (system cal.)	
13	Standard gain horn antenna	18240-20	Flann Microwave	483	480294	Calibration not necessary	
14	Standard gain horn antenna	20240-20	Flann Microwave	411	480297	Calibration not necessary	
15	Preamplifier 18 GHz - 26 GHz	JS4-18002600-20-5A	MITEQ Hauppauge N.Y.	658697	480342	02/17/2016	02/2018
16	Preamplifier 12 GHz - 18 GHz	JS3-12001800-16-5A	MITEQ Hauppauge N.Y.	571667	480343	02/18/2016	02/2018
17	RF-cable 2m	Insulated Wire Inc.	Insulated Wire	KPS-1533-800-KPS	480302	Calibration not necessary	

7 Report history

Report Number	Date	Comment
F170032E2	05/08/2017	Document created
-	-	-
-	-	-

8 List of annexes

Annex A	Test set-up photos	5 pages
170032_a.JPG: EASYSCAN Link, test setup fully anechoic chamber		
170032_c.JPG: EASYSCAN Link, test setup fully anechoic chamber		
170032_b.JPG: EASYSCAN Link, test setup fully anechoic chamber		
170032_d.JPG: EASYSCAN Link, test setup fully anechoic chamber		
170032_e.JPG: EASYSCAN Link, test setup fully anechoic chamber		
Annex B	External photos	3 pages
170032_1.JPG: EASYSCAN Link, 3D view 1		
170032_2.JPG: EASYSCAN Link, 3D view 2		
170032_3.JPG: EASYSCAN Link, detail view to type plate		