

# FCC CFR47 PART 22H, 24E, 27 CERTIFICATION TEST REPORT

## FCC ID: ZSHX6

**Product:** Mobile phone

**Trade Mark:** Kenxinda

**Model Number:** X6

**Family Model:** N/A

**Report No.:** STR190625004006E

### Prepared for

SHENZHEN KENXINDA TECHNOLOGY CO.,LTD  
18TH FLOOR,FUCHUN ORIENT BUILDING, SHENNAN AV 7006,  
SHENZHEN, China

### Prepared by

Shenzhen NTEK Testing Technology Co., Ltd.  
1/F, Building E, Fenda Science Park, Sanwei Community, Xixiang Street  
Bao'an District, Shenzhen 518126 P.R. China  
Tel.: +86-755-6115 6588 Fax.: +86-755-6115 6599  
Website:<http://www.ntek.org.cn>

TEST RESULT CERTIFICATION

Applicant's name : SHENZHEN KENXINDA TECHNOLOGY CO.,LTD
Address : 18TH FLOOR,FUCHUN ORIENT BUILDING, SHENNAN AV 7006, SHENZHEN, China
Manufacturer's Name : SHENZHEN KENXINDA TECHNOLOGY CO.,LTD
Address : 18TH FLOOR,FUCHUN ORIENT BUILDING, SHENNAN AV 7006, SHENZHEN, China
Product name : Mobile phone
Model and/or type reference : X6
Family Model: N/A
Standards : FCC CFR 47 Part 22H, Part 24E, Part 27
Test procedure : ANSI C63.26:2015
ANSI/TIA-603-E-2016

This device described above has been tested by NTEK, and the test results show that the equipment under test (EUT) is in compliance with the FCC requirements. And it is applicable only to the tested sample identified in the report.

This report shall not be reproduced except in full, without the written approval of NTEK, this document may be altered or revised by NTEK, personal only, and shall be noted in the revision of the document.

Date of Test :
Date (s) of performance of tests : 16 Aug. 2019 ~ 18 Sep. 2019
Date of Issue : 19 Sep. 2019
Test Result : Pass

Testing Engineer : [Signature: Allen Liu]
(Allen Liu)
Technical Manager : [Signature: Jason Chen]
(Jason Chen)
Authorized Signatory : [Signature: Sam Chen]
(Sam Chen)

## TABLE OF CONTENTS

<b>1. GENERAL INFORMATION .....</b>	<b>5</b>
<b>1. GENERAL INFORMATION .....</b>	<b>5</b>
<b>1.1 PRODUCT DESCRIPTION .....</b>	<b>5</b>
<b>1.2 RELATED SUBMITTAL(S) / GRANT (S).....</b>	<b>6</b>
<b>1.3 TEST METHODOLOGY.....</b>	<b>6</b>
<b>1.4 TEST FACILITY.....</b>	<b>6</b>
<b>MEASUREMENT UNCERTAINTY .....</b>	<b>6</b>
<b>1.5 SPECIAL ACCESSORIES.....</b>	<b>6</b>
<b>1.6 WORST-CASE CONFIGURATION AND MODE.....</b>	<b>6</b>
<b>2. SYSTEM TEST CONFIGURATION .....</b>	<b>7</b>
<b>2.1 EUT CONFIGURATION.....</b>	<b>7</b>
<b>2.2 EUT EXERCISE .....</b>	<b>7</b>
<b>2.3 CONFIGURATION OF EUT SYSTEM.....</b>	<b>7</b>
<b>2.4 TEST SETUP .....</b>	<b>8</b>
<b>3. TEST AND MEASUREMENT EQUIPMENT .....</b>	<b>9</b>
<b>4. OUTPUT POWER.....</b>	<b>10</b>
<b>4.1 OUTPUT POWER MEASUREMENT .....</b>	<b>10</b>
<b>5. OCCUPIED BANDWIDTH.....</b>	<b>12</b>
<b>6. BANDEDGE AND EMISSION MASK .....</b>	<b>13</b>
<b>7. OUT OF BAND EMISSIONS.....</b>	<b>14</b>
<b>7.1 MEASUREMENT METHOD .....</b>	<b>14</b>
<b>8. RADIATED MEASUREMENT .....</b>	<b>15</b>
<b>8.1. RADIATED POWER (ERP &amp; EIRP).....</b>	<b>15</b>
<b>8.2 LTE BAND 2 .....</b>	<b>16</b>
<b>8.3 LTE BAND 4 .....</b>	<b>20</b>

**8.4 LTE BAND 7 ..... 24**

**8.5 LTE BAND 17 ..... 26**

**9. SPURIOUS RADIATION EMISSION .....28**

**9.1 LTE BAND 2 ..... 30**

**9.2 LTE BAND 4 ..... 32**

**9.3 LTE BAND 7 ..... 33**

**9.4 LTE BAND 17 ..... 34**

**10. FREQUENCY STABILITY .....35**

**10.1 LTE BAND 2 ..... 36**

**10.2 LTE BAND 4 ..... 38**

**10.3 LTE BAND 7 ..... 40**

**10.4 LTE BAND 17 ..... 42**

**11. PEAK-TO-AVERAGE RATIO .....44**

**11.1 Description of the PAR Measurement ..... 44**

**11.2 Measuring Instruments ..... 44**

**11.3 Test Procedures..... 44**

**11.4 Test Setup..... 44**

## 1. GENERAL INFORMATION

### 1.1 PRODUCT DESCRIPTION

A major technical description of EUT is described as following:

Product Designation:	Mobile phone
Trade Mark	Kenxinda
Model Name	X6
Family Model	N/A
Model Difference	N/A
FCC ID:	ZSHX6
Frequency Bands:	U.S. Bands: <input checked="" type="checkbox"/> LTE FDD Band 2, 4, 7, 17
Frequency Range:	LTE FDD Band 2 Uplink: 1850MHz-1910MHz, Downlink: 1930MHz-1990MHz; LTE FDD Band 4 Uplink: 1710MHz-1755MHz, Downlink: 2110MHz-2155MHz; LTE-FDD Band 7 Uplink: 2500MHz-2570MHz, Downlink: 2620MHz-2690MHz; LTE FDD Band 17 Uplink: 704MHz-716MHz, Downlink: 734MHz-746MHz;
Type of Modulation:	QPSK/16QAM
SIM Card	SIM 1 and SIM 2 is a chipset unit and tested as a single chipset. The SIM 1 is chosen for test.
Antenna:	PIFA Antenna
Antenna gain:	0.8dBi
Power Supply:	DC 3.8V/3000mAh from Battery or DC 5V from USB Port.
Adapter:	Model: K12S Input: 100-240V~50/60Hz 0.25A Output: 5V $\overline{\text{---}}$ 1A
Extreme Vol. Limits:	DC 3.4V to DC 4.4V (Nominal DC 3.8V) (Note 1)
HW Version	S580-MB-V2.0
SW Version	X6.KXD.S580B.32+3.M.V01.01.20190905
** Note1: The High Voltage DC 4.4V and Low Voltage 3.4V was declared by manufacturer, The EUT couldn't be operate normally with higher or lower voltage.	

**1.2 RELATED SUBMITTAL(S) / GRANT (S)**

This submittal(s) (test report) is intended for **FCC ID: ZSHX6** filing to comply with the FCC Part 22H&24E &27.

**1.3 TEST METHODOLOGY**

The tests documented in this report were performed in accordance with ANSI/TIA-603-E-2016, FCC CFR 47 Part 2, Part 22, Part 24, Part 27, ANSI C63.26:2015.

**1.4 TEST FACILITY**

The test site used to collect the radiated data is located at:

ShenZhen NTEK Testing Technology Co., Ltd.

1/F, Building E, Fenda Science Park, Sanwei Community, Xixiang Street, Bao'an District, Shenzhen 518126 P.R.China.

The test site is constructed and calibrated to meet the FCC requirements in documents ANSI C63.26:2015& ANSI C63.4: 2014.

FCC Registration No.:463705

IC Registration No.:9270A-1,

CNAS Registration No.:L5516

**MEASUREMENT UNCERTAINTY**

The reported uncertainty of measurement, where expended uncertainty U is based on a standard uncertainty multiplied by a coverage factor of k=2, providing a level of confidence of approximately 95 %.

No.	Item	Uncertainty
1	Measuring Uncertainty for a Level of Confidence of 95% (U = 2Uc(y))	2.5dB

**1.5 SPECIAL ACCESSORIES**

The battery and the charger, earphone supplied by the applicant were used as accessories and being tested with EUT intended for FCC grant together.

**1.6 WORST-CASE CONFIGURATION AND MODE**

The worst-case scenario for all measurements is based on the investigation results.

The device has LTE Bands of: Band 2, Band 4, Band 7, Band 17.

The RB Size was selected to measure for peak or average ERP and EIRP, which was based on the conducted power verification baseline data.

For the fundamental investigation of radiated emissions, the EUT is investigated for vertical and horizontal antenna orientations and X Y and Z orientations of the EUT alone. After the investigations the worst case was determined to be at X orientation for all LTE bands.

## 2. SYSTEM TEST CONFIGURATION

### 2.1 EUT CONFIGURATION

The EUT configuration for testing is installed on RF field strength measurement to meet the Commission’s requirement and operating in a manner which intends to maximize its emission characteristics in a continuous normal application.

### 2.2 EUT EXERCISE

The Transmitter was operated in the maximum output power mode through Communication Tester. The TX frequency was fixed which was for the purpose of the measurements.

### 2.3 CONFIGURATION OF EUT SYSTEM

Table 2-1 Equipment Used in EUT System

Item	Equipment	Model No.	ID or Specification	Note
1	Mobile phone	X6	FCC ID: ZSHX6	EUT

*Note: All the accessories have been used during the test.  
the following “EUT” in setup diagram means EUT system.*

2.4 TEST SETUP

CONDUCTED SETUP DIAGRAM FOR TESTS

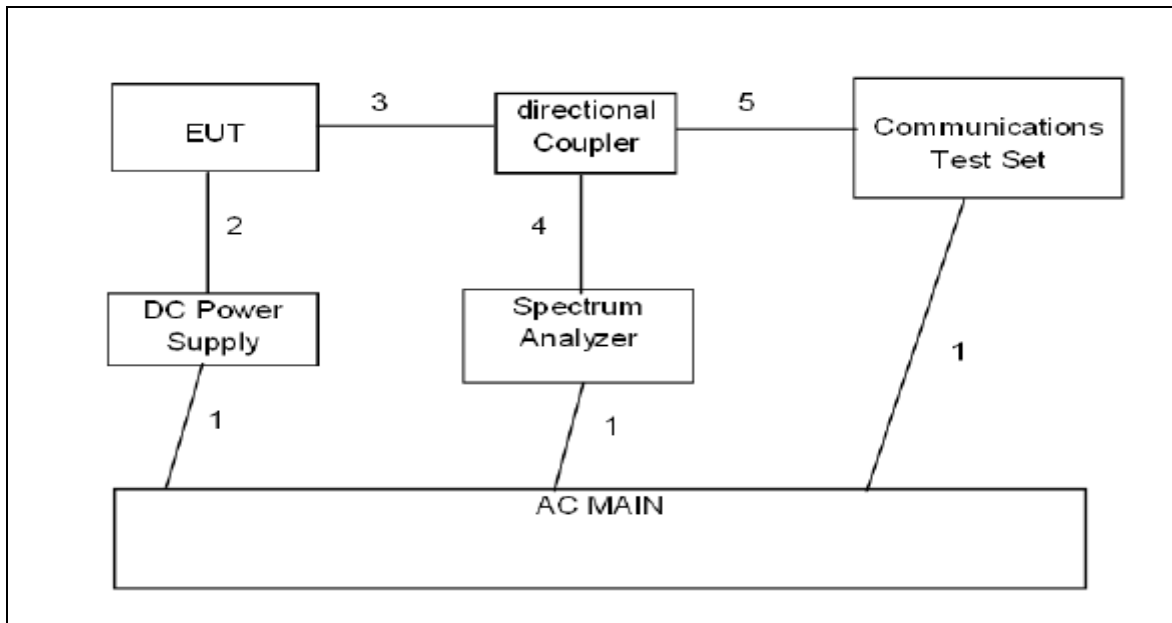

RADIATED SETUP DIAGRAM FOR TESTS

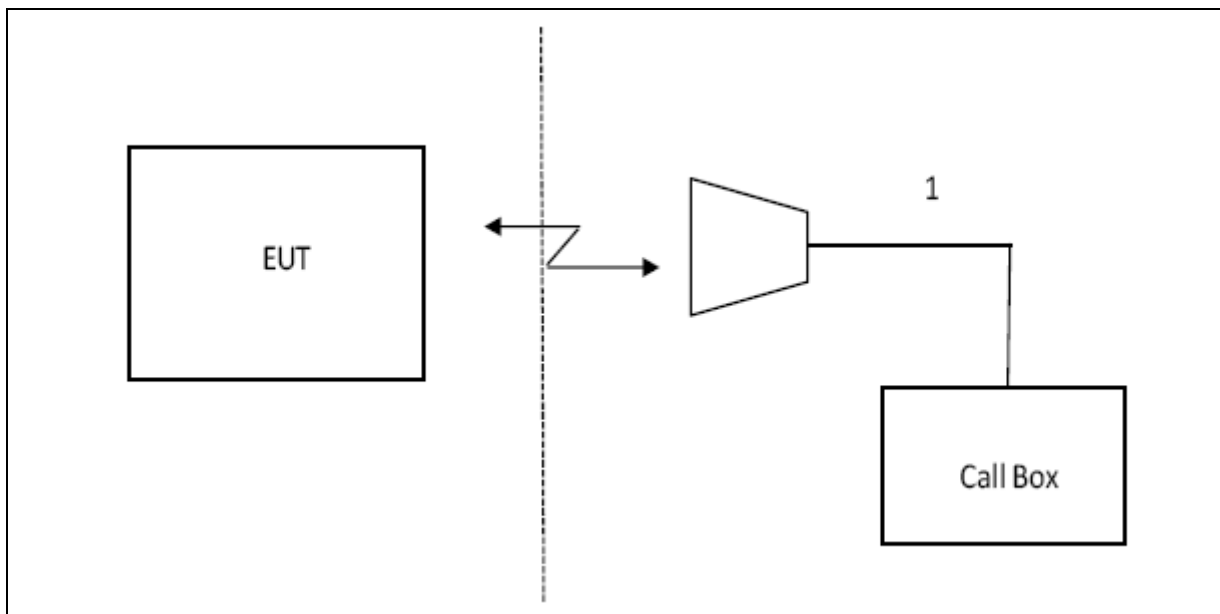



### 3. TEST AND MEASUREMENT EQUIPMENT

The following test and measurement equipment was utilized for the tests documented in this report:

NAME OF EQUIPMENT	MANUFACTURER	MODEL	SERIAL NUMBER	NEXT CAL. DATE
SPECTRUM ANALYZER	AGILENT	N9020A	MY49100060	2019.10.07
TEST RECEIVER	R&S	ESCI	A0304218	2020.05.12
COMMUNICATION TESTER	R&S	CMU200	117858	2020.05.12
COMMUNICATION TESTER	R&S	CMW500	148500	2020.05.12
TEST RECEIVER	R&S	ESPI	101318	2020.05.12
LISN	SCHWARZBECK	NSLK8127	A0304233	2020.05.12
CLIMATE CHAMBER	ALBATROSS	--	--	2020.05.12
Loop Antenna	ARA	PLA-1030/B	1029	2020.05.12
Biological Antenna	TESEQ	CBL6111D	31216	2020.05.12
Horn Antenna	EM	EM-AH-10180	2011071402	2020.05.12
DC Power Source	N/A	PS-6005D	20170402923	2020.05.12

## 4. OUTPUT POWER

### 4.1 OUTPUT POWER MEASUREMENT

#### LTE Measurement Procedure:

All LTE bands conducted power peak and average are obtained from the CMW500 telecommunication test set. The following tests were conducted according to the test requirements outlined in section 6.2 of the 3GPP TS36.101 specification.

UE Power Class: 3 (23 +/- 2dBm). The allowed Maximum Power Reduction (MPR) for the maximum output power due to higher order modulation and transmit bandwidth configuration (resource blocks) is specified in Table 6.2.3-1 of the 3GPP TS36.101.

**Table 6.2.3-1: Maximum Power Reduction (MPR) for Power Class 3**

Modulation	Channel bandwidth / Transmission bandwidth (RB)						MPR (dB)
	1.4 MHz	3.0 MHz	5 MHz	10 MHz	15 MHz	20 MHz	
QPSK	> 5	> 4	> 8	> 12	> 16	> 18	≤ 1
16 QAM	≤ 5	≤ 4	≤ 8	≤ 12	≤ 16	≤ 18	≤ 1
16 QAM	> 5	> 4	> 8	> 12	> 16	> 18	≤ 2

The allowed A-MPR values specified below in Table 6.2.4.-1 of 3GPP TS36.101 are in addition to the allowed MPR requirements. All the measurements below were performed with A-MPR disabled, by using Network Signaling Value of "NS\_01".3

**Table 6.2.4-1: Additional Maximum Power Reduction (A-MPR)**

Network Signalling value	Requirements (sub-clause)	E-UTRA Band	Channel bandwidth (MHz)	Resources Blocks ( $N_{RB}$ )	A-MPR (dB)
NS_01	6.6.2.1.1	Table 5.5-1	1.4, 3, 5, 10, 15, 20	Table 5.6-1	NA
NS_03	6.6.2.2.1	2, 4, 10, 23, 25, 35, 36	3	>5	$\leq 1$
			5	>6	$\leq 1$
			10	>6	$\leq 1$
			15	>8	$\leq 1$
			20	>10	$\leq 1$
NS_04	6.6.2.2.2	41	5	>6	$\leq 1$
			10, 15, 20	See Table 6.2.4-4	
NS_05	6.6.3.3.1	1	10, 15, 20	$\geq 50$	$\leq 1$
NS_06	6.6.2.2.3	12, 13, 14, 17	1.4, 3, 5, 10	Table 5.6-1	n/a
NS_07	6.6.2.2.3	13	10	Table 6.2.4-2	Table 6.2.4-2
	6.6.3.3.2				
NS_08	6.6.3.3.3	19	10, 15	> 44	$\leq 3$
NS_09	6.6.3.3.4	21	10, 15	> 40	$\leq 1$
				> 55	$\leq 2$
NS_10		20	15, 20	Table 6.2.4-3	Table 6.2.4-3
NS_11	6.6.2.2.1	23 <sup>1</sup>	1.4, 3, 5, 10	Table 6.2.4-5	Table 6.2.4-5
..					
NS_32	-	-	-	-	-

Note 1: Applies to the lower block of Band 23, i.e. a carrier placed in the 2000-2010 MHz region.

Test data reference attachment.

## 5. OCCUPIED BANDWIDTH

### RULE PART(S)

FCC: §2.1049

### LIMITS

For reporting purposes only

### TEST PROCEDURE

The transmitter output was connected to a calibrated coaxial cable and coupler, the other end of which was connected to a spectrum analyzer. The occupied bandwidth was measured with the spectrum analyzer at the low, middle and high channel in each band. The -26dB bandwidth was also measured and recorded.

### MODES TESTED

- LTE Band 2
- LTE Band 4
- LTE Band 7
- LTE Band 17

### RESULTS

**PASS**

Test data reference attachment.

## 6. BANDEDGE AND EMISSION MASK

### RULE PART(S)

FCC: §2.1051, §22.901, §22.917, §24.238, §27.53, and §90.691

FCC: §22.359

### LIMITS

FCC: §22.359, §24.238,

The power of any emission outside of the authorized operating frequency ranges must be attenuated below the transmitting power (P) by a factor of at least  $43 + 10 \log (P)$  dB.

(m)(4) For mobile digital stations, the attenuation factor shall be not less than  $40 + 10 \log (P)$  dB on all frequencies between the channel edge and 5 megahertz from the channel edge,  $43 + 10 \log (P)$  dB on all frequencies between 5 megahertz and X megahertz from the channel edge, and  $55 + 10 \log (P)$  dB on all frequencies more than X megahertz from the channel edge, where X is the greater of 6 megahertz or the actual emission bandwidth as defined in paragraph (m)(6) of this section. In addition, the attenuation factor shall not be less that  $43 + 10 \log (P)$  dB on all frequencies between 2490.5 MHz and 2496 MHz and  $55 + 10 \log (P)$  dB at or below 2490.5 MHz. Mobile Satellite Service licensees operating on frequencies below 2495 MHz may also submit a documented interference complaint against BRS licensees operating on channel BRS Channel 1 on the same terms and conditions as adjacent channel BRS or EBS licensees. Show citation box.

### TEST PROCEDURE

The transmitter output was connected to a CMW500 Test Set and configured to operate at maximum power. The band edge emissions were measured at the required operating frequencies in each band on the Spectrum Analyzer.

For each band edge measurement:

Set the spectrum analyzer span to include the block edge frequency (704, 716, 824, 849, 1710 and 1755, 1850 and 1910MHz)

Set a marker to point the corresponding band edge frequency in each test case.

Set display line at -13 dBm

Set resolution bandwidth to at least 1% of emission bandwidth.

### MODES TESTED

LTE Band 2

LTE Band 4

LTE Band 7

LTE Band 17

### RESULTS

Test data reference attachment.

## 7. OUT OF BAND EMISSIONS

### RULE PART(S)

FCC: §2.1051, §22.901, §22.917, §24.238 and §27.53

### LIMITS

The power of any emission outside of the authorized operating frequency ranges must be attenuated below the transmitting power (P) by a factor of at least  $43 + 10 \log (P)$  dB.

### TEST PROCEDURE

The RF output of the transmitter was connected to a spectrum analyzer through a calibrated coaxial cable. Sufficient scans were taken to show the out-of-band Emissions, if any, up to 10th harmonic. Multiple sweeps were recorded in maximum hold mode using a peak detector to ensure that the worst-case emissions were caught.

For each out of band emissions measurement:

Set display line at -13 dBm

Set RBW & VBW to 100 kHz for the measurement below 1 GHz, and 1 MHz for the measurement above 1 GHz.

### **MODES TESTED**

LTE Band 2

LTE Band 4

LTE Band 7

LTE Band 17

### 7.1 MEASUREMENT METHOD

The test set up and general procedure is similar to conducted peak output power test. Only different for setting the measurement configuration of the measuring instrument of Spectrum Analyzer.

Test data reference attachment.

## 8. RADIATED MEASUREMENT

### 8.1. RADIATED POWER (ERP & EIRP)

#### RULE PART(S)

FCC: §2.1046, §22.913, §24.232 and §27.50

#### LIMITS:

22.913(a) - The ERP of mobile transmitters and auxiliary test transmitters must not exceed 7 Watts.

27.50 (c) (10) the following power and antenna height requirements apply to stations transmitting in the 698–746 MHz band, the portable stations (hand-held devices) are limited to 3 watts ERP.

27.50 (b)(10) Portable stations (hand-held devices) transmitting in the 746–757 MHz, 758–763 MHz, 776–793 MHz, and 805–806 MHz bands are limited to 3 watts ERP.

27.50 (d)(4) The following power and antenna height requirements apply to stations transmitting in the 1710–1755 MHz and 2110–2155 MHz bands: Fixed, mobile, and portable (hand-held) stations operating in the 1710–1755 MHz band are limited to 1 watt EIRP.

#### TEST PROCEDURE

ANSI/TIA-603-E Clause 2.2.17

KDB 971168 v02r01 RF power output using broadband peak and average power meter method.

KDB 971168 D01 Power Meas License Digital Systems v02r01, “Measurement Guidance for Certification of Licensed Digital Transmitters”

#### MODES TESTED

LTE Band 2

LTE Band 4

LTE Band 7

LTE Band 17

#### RESULTS

Pass

8.2 LTE BAND 2

Radiated Power (EIRP) for Band 2									
Mode	RB/RB SIZE	Frequency	Result						Conclusion
			SG Level (dBm)	Cable Loss (dBm)	Antenna Gain (dB)	Max. EIRP Average (dBm)	Max. EIRP Average (mW)	Polarization Of Max. ERP	
1.4MHz Band QPSK	1/ Mid	1850.7	-2.03	3.76	28.24	22.45	175.879	Horizontal	Pass
		1880	-1.77	3.91	28.22	22.54	179.448	Horizontal	Pass
		1909.3	-1.78	3.93	28.20	22.49	177.383	Horizontal	Pass
3.0MHz Band QPSK	1/ Mid	1851.5	-2.03	3.77	28.23	22.43	174.971	Horizontal	Pass
		1880	-1.90	3.91	28.24	22.43	175.175	Horizontal	Pass
		1908.5	-1.82	3.94	28.25	22.49	177.439	Horizontal	Pass
5.0MHz Band QPSK	1/ Mid	1852.5	-2.17	3.77	28.31	22.37	172.730	Horizontal	Pass
		1880	-1.88	3.91	28.22	22.43	175.174	Horizontal	Pass
		1907.5	-1.98	3.94	28.20	22.28	168.961	Horizontal	Pass
10.0MHz Band QPSK	1/ Mid	1855	-2.14	3.79	28.33	22.40	173.718	Horizontal	Pass
		1880	-1.77	3.95	28.22	22.50	177.661	Horizontal	Pass
		1905	-1.67	3.97	28.19	22.55	179.823	Horizontal	Pass
15.0MHz Band QPSK	1/ Mid	1857.5	-1.89	3.79	28.34	22.66	184.678	Horizontal	Pass
		1880	-1.61	3.95	28.22	22.66	184.455	Horizontal	Pass
		1902.5	-1.52	3.97	28.18	22.69	185.631	Horizontal	Pass
20.0MHz Band QPSK	1/ Mid	1860	-2.09	3.81	28.35	22.45	175.753	Horizontal	Pass
		1880	-1.86	3.96	28.22	22.40	173.582	Horizontal	Pass
		1900	-1.56	4.00	28.16	22.60	182.105	Horizontal	Pass
1.4MHz Band QPSK	1/ Mid	1850.7	-2.07	3.76	28.24	22.41	174.330	Vertical	Pass
		1880	-1.87	3.91	28.22	22.44	175.372	Vertical	Pass
		1909.3	-1.88	3.93	28.20	22.39	173.561	Vertical	Pass
3.0MHz Band QPSK	1/ Mid	1851.5	-1.89	3.77	28.23	22.57	180.736	Vertical	Pass
		1880	-1.74	3.91	28.24	22.59	181.458	Vertical	Pass
		1908.5	-1.67	3.94	28.25	22.64	183.802	Vertical	Pass
5.0MHz Band QPSK	1/ Mid	1852.5	-2.09	3.77	28.31	22.45	175.765	Vertical	Pass
		1880	-1.79	3.91	28.22	22.52	178.832	Vertical	Pass
		1907.5	-1.96	3.94	28.20	22.30	169.897	Vertical	Pass
10.0MHz Band	1/ Mid	1855	-2.03	3.79	28.33	22.51	178.416	Vertical	Pass
		1880	-1.82	3.95	28.22	22.45	175.818	Vertical	Pass



QPSK		1905	-1.85	3.97	28.19	22.37	172.503	Vertical	Pass
15.0MHz z Band QPSK	1/ Mid	1857.5	-2.00	3.79	28.34	22.55	180.092	Vertical	Pass
		1880	-1.75	3.95	28.22	22.52	178.463	Vertical	Pass
		1902.5	-1.47	3.97	28.18	22.74	187.861	Vertical	Pass
20.0MHz z Band QPSK	1/ Mid	1860	-2.01	3.81	28.35	22.53	179.152	Vertical	Pass
		1880	-1.91	3.96	28.22	22.35	171.618	Vertical	Pass
		1900	-1.39	4.00	28.16	22.77	189.442	Vertical	Pass

Note:

SG Level= Signal generator output

Max. EIRP Average (dBm)= Antenna Gain(dB)+ SG Level (dBm)- Cable Loss(dBm)

Radiated Power (EIRP) for Band 2									
Mode	RB/RB SIZE	Frequency	Result					Polarization Of Max. ERP	Conclusion
			SG Level (dBm)	Cable Loss (dBm)	Antenna Gain (dB)	Max. EIRP Average (dBm)	Max. EIRP Average (mW)		
1.4MHz Band 16 QAM	1/ Mid	1850.7	-2.45	3.76	28.24	22.03	159.409	Horizontal	Pass
		1880	-2.22	3.91	28.22	22.09	161.898	Horizontal	Pass
		1909.3	-2.16	3.93	28.20	22.11	162.616	Horizontal	Pass
3.0MHz Band 16 QAM	1/ Mid	1851.5	-2.45	3.77	28.23	22.01	158.955	Horizontal	Pass
		1880	-2.41	3.91	28.24	21.92	155.768	Horizontal	Pass
		1908.5	-2.26	3.94	28.25	22.05	160.249	Horizontal	Pass
5.0MHz Band 16 QAM	1/ Mid	1852.5	-2.54	3.77	28.31	22.00	158.318	Horizontal	Pass
		1880	-2.14	3.91	28.22	22.17	164.643	Horizontal	Pass
		1907.5	-2.26	3.94	28.20	22.00	158.638	Horizontal	Pass
10.0MHz Band 16 QAM	1/ Mid	1855	-2.48	3.79	28.33	22.06	160.645	Horizontal	Pass
		1880	-2.16	3.95	28.22	22.11	162.712	Horizontal	Pass
		1905	-2.21	3.97	28.19	22.01	158.738	Horizontal	Pass
15.0MHz Band 16 QAM	1/ Mid	1857.5	-2.54	3.79	28.34	22.01	158.985	Horizontal	Pass
		1880	-2.27	3.95	28.22	22.00	158.537	Horizontal	Pass
		1902.5	-2.18	3.97	28.18	22.03	159.707	Horizontal	Pass
20.0MHz Band 16 QAM	1/ Mid	1860	-2.50	3.81	28.35	22.04	160.061	Horizontal	Pass
		1880	-2.13	3.96	28.22	22.13	163.274	Horizontal	Pass
		1900	-2.24	4.00	28.16	21.92	155.615	Horizontal	Pass
1.4MHz Band 16 QAM	1/ Mid	1850.7	-2.39	3.76	28.24	22.09	161.651	Vertical	Pass
		1880	-2.32	3.91	28.22	21.99	158.180	Vertical	Pass
		1909.3	-2.11	3.93	28.20	22.16	164.363	Vertical	Pass
3.0MHz Band 16 QAM	1/ Mid	1851.5	-2.47	3.77	28.23	21.99	158.246	Vertical	Pass
		1880	-2.40	3.91	28.24	21.93	156.125	Vertical	Pass
		1908.5	-2.24	3.94	28.25	22.07	161.201	Vertical	Pass
5.0MHz Band 16 QAM	1/ Mid	1852.5	-2.49	3.77	28.31	22.05	160.450	Vertical	Pass
		1880	-2.34	3.91	28.22	21.97	157.518	Vertical	Pass
		1907.5	-2.13	3.94	28.20	22.13	163.465	Vertical	Pass
10.0MHz Band 16 QAM	1/ Mid	1855	-2.65	3.79	28.33	21.89	154.416	Vertical	Pass
		1880	-2.34	3.95	28.22	21.93	155.992	Vertical	Pass
		1905	-2.43	3.97	28.19	21.79	150.848	Vertical	Pass
15.0MHz Band	1/ Mid	1857.5	-2.66	3.79	28.34	21.89	154.432	Vertical	Pass
		1880	-2.31	3.95	28.22	21.96	157.161	Vertical	Pass

16 QAM		1902.5	-2.26	3.97	28.18	21.95	156.818	Vertical	Pass
20.0MH	1/ Mid	1860	-2.45	3.81	28.35	22.09	161.718	Vertical	Pass
z Band		1880	-2.08	3.96	28.22	22.18	165.355	Vertical	Pass
16 QAM		1900	-2.12	4.00	28.16	22.04	160.122	Vertical	Pass

Note:

SG Level= Signal generator output

Max. EIRP Average (dBm)= Antenna Gain(dB)+ SG Level (dBm)- Cable Loss(dBm)

8.3 LTE BAND 4

Radiated Power (EIRP) for Band 4									
Mode	RB/RB SIZE	Frequency	Result						Conclusion
			SG Level (dBm)	Cable Loss (dBm)	Antenna Gain (dB)	Max. EIRP Average (dBm)	Max. EIRP Average (mW)	Polarization Of Max. ERP	
1.4MHz Band QPSK	1/ Mid	1710.7	-2.71	3.12	27.58	21.75	149.690	Horizontal	Pass
		1732.5	-2.80	3.27	27.61	21.54	142.669	Horizontal	Pass
		1754.3	-2.44	3.29	27.63	21.90	155.053	Horizontal	Pass
3.0MHz Band QPSK	1/ Mid	1711.5	-2.83	3.13	27.61	21.65	146.253	Horizontal	Pass
		1732.5	-2.60	3.27	27.61	21.74	149.414	Horizontal	Pass
		1753.5	-2.52	3.30	27.62	21.80	151.266	Horizontal	Pass
5.0MHz Band QPSK	1/ Mid	1712.5	-2.50	3.13	27.63	22.00	158.503	Horizontal	Pass
		1732.5	-2.20	3.27	27.61	22.14	163.522	Horizontal	Pass
		1752.5	-2.26	3.30	27.60	22.04	159.803	Horizontal	Pass
10.0MHz Band QPSK	1/ Mid	1715	-2.54	3.15	27.64	21.95	156.715	Horizontal	Pass
		1732.5	-2.53	3.31	27.61	21.77	150.272	Horizontal	Pass
		1750	-2.43	3.33	27.59	21.83	152.574	Horizontal	Pass
15.0MHz Band QPSK	1/ Mid	1717.5	-2.85	3.15	27.65	21.65	146.189	Horizontal	Pass
		1732.5	-2.43	3.31	27.61	21.87	153.816	Horizontal	Pass
		1747.5	-2.45	3.33	27.57	21.79	151.004	Horizontal	Pass
20.0MHz Band QPSK	1/ Mid	1720	-2.67	3.17	27.66	21.82	151.899	Horizontal	Pass
		1732.5	-2.44	3.32	27.61	21.85	153.047	Horizontal	Pass
		1745	-2.55	3.36	27.56	21.65	146.093	Horizontal	Pass
1.4MHz Band QPSK	1/ Mid	1710.7	-2.66	3.12	27.58	21.80	151.296	Vertical	Pass
		1732.5	-2.60	3.27	27.61	21.74	149.186	Vertical	Pass
		1754.3	-2.58	3.29	27.63	21.76	149.934	Vertical	Pass
3.0MHz Band QPSK	1/ Mid	1711.5	-2.64	3.13	27.61	21.84	152.715	Vertical	Pass
		1732.5	-2.46	3.27	27.61	21.88	154.197	Vertical	Pass
		1753.5	-2.62	3.30	27.62	21.70	148.026	Vertical	Pass
5.0MHz Band QPSK	1/ Mid	1712.5	-2.38	3.13	27.63	22.12	162.992	Vertical	Pass
		1732.5	-2.29	3.27	27.61	22.05	160.174	Vertical	Pass
		1752.5	-2.21	3.30	27.60	22.09	161.671	Vertical	Pass
10.0MHz Band QPSK	1/ Mid	1715	-2.65	3.15	27.64	21.84	152.614	Vertical	Pass
		1732.5	-2.50	3.31	27.61	21.80	151.445	Vertical	Pass
		1750	-2.43	3.33	27.59	21.83	152.484	Vertical	Pass

15.0MH z Band QPSK	1/ Mid	1717.5	-2.78	3.15	27.65	21.72	148.531	Vertical	Pass
		1732.5	-2.38	3.31	27.61	21.92	155.704	Vertical	Pass
		1747.5	-2.32	3.33	27.57	21.92	155.457	Vertical	Pass
20.0MH z Band QPSK	1/ Mid	1720	-2.29	3.17	27.66	22.20	165.825	Vertical	Pass
		1732.5	-2.47	3.32	27.61	21.82	151.952	Vertical	Pass
		1745	-2.44	3.36	27.56	21.76	150.108	Vertical	Pass

Note:

SG Level= Signal generator output

Max. EIRP Average (dBm)= Antenna Gain(dB)+ SG Level (dBm)- Cable Loss(dBm)

Radiated Power (EIRP) for Band 4									
Mode	RB/RB SIZE	Frequency	Result						Conclusion
			SG Level (dBm)	Cable Loss (dBm)	Antenna Gain (dB)	Max. EIRP Average (dBm)	Max. EIRP Average (mW)	Polarization Of Max. ERP	
1.4MHz Band 16 QAM	1/ Mid	1710.7	-3.06	3.12	27.58	21.40	138.032	Horizontal	Pass
		1732.5	-2.93	3.27	27.61	21.41	138.242	Horizontal	Pass
		1754.3	-3.05	3.29	27.63	21.29	134.726	Horizontal	Pass
3.0MHz Band 16 QAM	1/ Mid	1711.5	-3.85	3.13	27.61	20.63	115.720	Horizontal	Pass
		1732.5	-3.71	3.27	27.61	20.63	115.673	Horizontal	Pass
		1753.5	-3.62	3.30	27.62	20.70	117.363	Horizontal	Pass
5.0MHz Band 16 QAM	1/ Mid	1712.5	-3.99	3.13	27.63	20.51	112.516	Horizontal	Pass
		1732.5	-3.86	3.27	27.61	20.48	111.602	Horizontal	Pass
		1752.5	-2.87	3.30	27.60	21.43	138.951	Horizontal	Pass
10.0MHz Band 16 QAM	1/ Mid	1715	-3.22	3.15	27.64	21.27	133.986	Horizontal	Pass
		1732.5	-2.92	3.31	27.61	21.38	137.332	Horizontal	Pass
		1750	-3.13	3.33	27.59	21.13	129.656	Horizontal	Pass
15.0MHz Band 16 QAM	1/ Mid	1717.5	-3.06	3.15	27.65	21.44	139.182	Horizontal	Pass
		1732.5	-2.89	3.31	27.61	21.41	138.308	Horizontal	Pass
		1747.5	-2.79	3.33	27.57	21.45	139.500	Horizontal	Pass
20.0MHz Band 16 QAM	1/ Mid	1720	-3.31	3.17	27.66	21.18	131.353	Horizontal	Pass
		1732.5	-3.09	3.32	27.61	21.20	131.785	Horizontal	Pass
		1745	-2.92	3.36	27.56	21.28	134.363	Horizontal	Pass
1.4MHz Band 16 QAM	1/ Mid	1710.7	-3.11	3.12	27.58	21.35	136.605	Vertical	Pass
		1732.5	-2.98	3.27	27.61	21.36	136.663	Vertical	Pass
		1754.3	-2.99	3.29	27.63	21.35	136.415	Vertical	Pass
3.0MHz Band 16 QAM	1/ Mid	1711.5	-3.70	3.13	27.61	20.78	119.566	Vertical	Pass
		1732.5	-3.65	3.27	27.61	20.69	117.265	Vertical	Pass
		1753.5	-3.58	3.30	27.62	20.74	118.626	Vertical	Pass
5.0MHz Band 16 QAM	1/ Mid	1712.5	-3.91	3.13	27.63	20.59	114.584	Vertical	Pass
		1732.5	-3.69	3.27	27.61	20.65	116.250	Vertical	Pass
		1752.5	-3.81	3.30	27.60	20.49	112.049	Vertical	Pass
10.0MHz Band 16 QAM	1/ Mid	1715	-3.10	3.15	27.64	21.39	137.651	Vertical	Pass
		1732.5	-2.89	3.31	27.61	21.41	138.282	Vertical	Pass
		1750	-3.08	3.33	27.59	21.18	131.135	Vertical	Pass
15.0MHz Band	1/ Mid	1717.5	-3.25	3.15	27.65	21.25	133.348	Vertical	Pass
		1732.5	-3.10	3.31	27.61	21.20	131.878	Vertical	Pass

16 QAM		1747.5	-3.11	3.33	27.57	21.13	129.759	Vertical	Pass
20.0MH	1/ Mid	1720	-3.17	3.17	27.66	21.32	135.666	Vertical	Pass
z Band		1732.5	-3.01	3.32	27.61	21.28	134.329	Vertical	Pass
16 QAM		1745	-2.71	3.36	27.56	21.49	141.034	Vertical	Pass

Note:

SG Level= Signal generator output

Max. EIRP Average (dBm)= Antenna Gain(dB)+ SG Level (dBm)- Cable Loss(dBm)

8.4 LTE BAND 7

Radiated Power (EIRP) for Band 7									
Mode	RB/ RB SIZE	Frequency	Result						Conclusion
			SG Level (dBm)	Cable Loss (dBm)	Antenna Gain (dB)	Max. EIRP Average (dBm)	Max. EIRP Average (mW)	Polarization Of Max. ERP	
5.0MHz Band QPSK	1/ Mid	2502.5	-0.95	4.54	27.75	22.26	168.267	Vertical	Pass
		2535	-0.83	4.69	27.72	22.20	165.959	Vertical	Pass
		2567.5	-0.92	4.71	27.71	22.08	161.436	Vertical	Pass
5.0MHz Band 16 QAM	1/ Mid	2502.5	-2.09	4.54	27.75	21.12	129.420	Vertical	Pass
		2535	-1.90	4.69	27.72	21.13	129.718	Vertical	Pass
		2567.5	-1.86	4.71	27.71	21.14	130.017	Vertical	Pass
10.0MHz Band QPSK	1/ Mid	2505	-0.94	4.55	27.76	22.27	168.655	Vertical	Pass
		2535	-0.63	4.69	27.72	22.40	173.780	Vertical	Pass
		2565	-0.76	4.72	27.70	22.22	166.725	Vertical	Pass
10.0MHz Band 16 QAM	1/ Mid	2505	-1.87	4.55	27.76	21.34	136.144	Vertical	Pass
		2535	-1.65	4.69	27.72	21.38	137.404	Vertical	Pass
		2565	-1.74	4.72	27.70	21.24	133.045	Vertical	Pass
15.0MHz Band QPSK	1/ Mid	2507.5	-0.77	4.55	27.77	22.00	158.489	Vertical	Pass
		2535	-0.66	4.69	27.72	21.89	154.525	Vertical	Pass
		2562.5	-0.84	4.72	27.69	22.05	160.325	Vertical	Pass
15.0MHz Band 16 QAM	1/ Mid	2507.5	-1.98	4.55	27.77	21.24	133.045	Vertical	Pass
		2535	-1.85	4.69	27.72	21.18	131.220	Vertical	Pass
		2562.5	-1.88	4.72	27.69	21.09	128.529	Vertical	Pass
20.0MHz Band QPSK	1/ Mid	2510	-1.21	4.57	27.78	22.45	175.792	Vertical	Pass
		2535	-1.10	4.73	27.72	22.37	172.584	Vertical	Pass
		2560	-0.88	4.75	27.68	22.13	163.305	Vertical	Pass
20.0MHz Band 16 QAM	1/ Mid	2510	-0.71	4.57	27.78	22.50	177.828	Vertical	Pass
		2535	-1.92	4.73	27.72	21.07	127.938	Vertical	Pass
		2560	-2.04	4.75	27.68	20.89	122.744	Vertical	Pass

Note:

SG Level= Signal generator output

Max. EIRP Average (dBm)= Antenna Gain(dB)+ SG Level (dBm)- Cable Loss(dBm)



Radiated Power (EIRP) for Band 7									
Mode	RB/ RB SIZE	Frequency	Result						Conclusion
			SG Level (dBm)	Cable Loss (dBm)	Antenna Gain (dB)	Max. EIRP Average (dBm)	Max. EIRP Average (mW)	Polarization Of Max. ERP	
5.0MHz Band QPSK	1/ Mid	2502.5	-1.39	4.54	27.75	21.82	152.09	Horizontal	Pass
		2535	-1.06	4.69	27.72	21.97	157.53	Horizontal	Pass
		2567.5	-1.04	4.71	27.71	21.96	157.02	Horizontal	Pass
5.0MHz Band 16 QAM	1/ Mid	2502.5	-2.27	4.54	27.75	20.94	124.05	Horizontal	Pass
		2535	-1.42	4.69	27.72	21.61	144.88	Horizontal	Pass
		2567.5	-2.08	4.71	27.71	20.92	123.64	Horizontal	Pass
10.0MHz Band QPSK	1/ Mid	2505	-1.22	4.55	27.76	21.99	158.10	Horizontal	Pass
		2535	-1.12	4.69	27.72	21.91	155.16	Horizontal	Pass
		2565	-1.21	4.72	27.70	21.77	150.27	Horizontal	Pass
10.0MHz Band 16 QAM	1/ Mid	2505	-2.45	4.55	27.76	20.76	119.03	Horizontal	Pass
		2535	-1.99	4.69	27.72	21.04	127.13	Horizontal	Pass
		2565	-2.21	4.72	27.70	20.77	119.40	Horizontal	Pass
15.0MHz Band QPSK	1/ Mid	2507.5	-1.57	4.55	27.77	21.65	146.08	Horizontal	Pass
		2535	-1.03	4.69	27.72	22.00	158.50	Horizontal	Pass
		2562.5	-1.58	4.72	27.69	21.39	137.70	Horizontal	Pass
15.0MHz Band 16 QAM	1/ Mid	2507.5	-2.14	4.55	27.77	21.08	128.17	Horizontal	Pass
		2535	-2.61	4.69	27.72	20.42	110.25	Horizontal	Pass
		2562.5	-1.81	4.72	27.69	21.16	130.65	Horizontal	Pass
20.0MHz Band QPSK	1/ Mid	2510	-1.52	4.57	27.78	21.69	147.72	Horizontal	Pass
		2535	-1.19	4.73	27.72	21.80	151.52	Horizontal	Pass
		2560	-0.98	4.75	27.68	21.95	156.67	Horizontal	Pass
20.0MHz Band 16 QAM	1/ Mid	2510	-1.70	4.57	27.78	21.51	141.58	Horizontal	Pass
		2535	-0.81	4.73	27.72	22.18	165.20	Horizontal	Pass
		2560	-1.14	4.75	27.68	21.79	151.01	Horizontal	Pass

Note:

SG Level= Signal generator output

Max. EIRP Average (dBm)= Antenna Gain(dB)+ SG Level (dBm)- Cable Loss(dBm)

8.5 LTE BAND 17

Radiated Power (ERP) for Band 17										
Mode	RB/ RB SIZE	Frequ ncy	Result							Conclu sion
			SG Level (dBm)	Cable Loss (dBm)	Anten na Gain (dB)	Corre ction (dB)	Max. ERP Averag e (dBm)	Max. ERP Averag e (mW)	Polarizati on Of Max. ERP	
5.0MHz Band QPSK	1/ Mid	706.5	5.89	1.91	19.23	2.15	21.06	127.522	Vertical	Pass
		710	5.78	1.91	19.26	2.15	20.98	125.386	Vertical	Pass
		713.5	5.80	1.92	19.33	2.15	21.06	127.555	Vertical	Pass
10.0MH z Band QPSK	1/ Mid	709	6.02	1.91	19.25	2.15	21.21	132.104	Vertical	Pass
		710	6.06	1.91	19.26	2.15	21.26	133.543	Vertical	Pass
		711	5.78	1.92	19.32	2.15	21.03	126.832	Vertical	Pass
5.0MHz Band QPSK	1/ Mid	706.5	6.00	1.91	19.23	2.15	21.17	130.901	Horizontal	Pass
		710	5.84	1.91	19.26	2.15	21.04	126.980	Horizontal	Pass
		713.5	5.85	1.92	19.33	2.15	21.11	128.982	Horizontal	Pass
10.0MH z Band QPSK	1/ Mid	709	5.98	1.91	19.25	2.15	21.17	130.899	Horizontal	Pass
		710	6.09	1.91	19.26	2.15	21.29	134.499	Horizontal	Pass
		711	5.73	1.92	19.32	2.15	20.98	125.229	Horizontal	Pass

Radiated Power (ERP) for Band 17											
Mode	RB/ RB SIZE	Frequ ncy	Result							Polarizati on Of Max. ERP	Conclu sion
			SG Level (dBm)	Cable Loss (dBm)	Anten na Gain (dB)	Corre ction (dB)	Max. ERP Averag e (dBm)	Max. ERP Averag e (mW)			
5.0MHz Band 16 QAM	1/ Mid	706.5	5.79	1.91	19.23	2.15	20.96	124.665	Vertical	Pass	
		710	5.76	1.91	19.26	2.15	20.96	124.814	Vertical	Pass	
		713.5	5.70	1.92	19.33	2.15	20.96	124.606	Vertical	Pass	
10.0MH z Band 16 QAM	1/ Mid	709	5.68	1.91	19.25	2.15	20.87	122.282	Vertical	Pass	
		710	5.58	1.91	19.26	2.15	20.78	119.641	Vertical	Pass	
		711	5.61	1.92	19.32	2.15	20.86	121.883	Vertical	Pass	
5.0MHz Band 16 QAM	1/ Mid	706.5	5.69	1.91	19.23	2.15	20.86	121.823	Horizontal	Pass	
		710	5.76	1.91	19.26	2.15	20.96	124.788	Horizontal	Pass	
		713.5	5.71	1.92	19.33	2.15	20.97	124.974	Horizontal	Pass	
10.0MH z Band 16 QAM	1/ Mid	709	5.66	1.91	19.25	2.15	20.85	121.662	Horizontal	Pass	
		710	5.87	1.91	19.26	2.15	21.07	128.018	Horizontal	Pass	
		711	5.54	1.92	19.32	2.15	20.79	120.005	Horizontal	Pass	

Note:

SG Level= Signal generator output

Max. ERP Average (dBm)= Antenna Gain(dB)+ SG Level (dBm)- Cable Loss(dBm)

## 9. SPURIOUS RADIATION EMISSION

### RULE PART(S)

FCC: §2.1053, §22.917, §24.238 and §27.53

### LIMIT

§22.917 (e) and §24.238 (a): Out of band emissions. The power of any emission outside of the authorized operating frequency ranges must be attenuated below the transmitting power (P) by a factor of at least  $43 + 10 \log (P)$  dB.

§27.53 (g) For operations in the 698–746 MHz band, the power of any emission outside a licensee's frequency band(s) of operation shall be attenuated below the transmitter power (P) within the licensed band(s) of operation, measured in watts, by at least  $43 + 10 \log (P)$  dB.

§27.53 (h) For operations in the 1710–1755 MHz and 2110–2155 MHz bands, the power of any emission outside a licensee's frequency block shall be attenuated below the transmitter power (P) by at least  $43 + 10 \log_{10}(P)$  dB.

### TEST PROCEDURE

For Cellular equipment - Compliance with these rules is based on the use of measurement instrumentation employing a resolution bandwidth of 100 kHz or greater. In the 1 MHz bands immediately outside and adjacent to the frequency block a resolution bandwidth of at least one percent of the emission bandwidth of the fundamental emission of the transmitter may be employed. A narrower resolution bandwidth is permitted in all cases to improve measurement accuracy provided the measured power is integrated over the full required measurement bandwidth (i.e. 100 kHz or 1 percent of emission bandwidth, as specified). The emission bandwidth is defined as the width of the signal between two points, one below the carrier center frequency and one above the carrier center frequency, outside of which all emissions are attenuated at least 26 dB below the transmitter power.

For PCS equipment - Compliance with these rules is based on the use of measurement instrumentation employing a resolution bandwidth of 1 MHz or greater. However, in the 1 MHz bands immediately outside and adjacent to the frequency block a resolution bandwidth of at least one percent of the emission bandwidth of the fundamental emission of the transmitter may be employed. A narrower resolution bandwidth is permitted in all cases to improve measurement accuracy provided the measured power is integrated over the full required measurement bandwidth ( i.e. 1 MHz or 1 percent of emission bandwidth, as specified). The emission bandwidth is defined as the width of the signal between two points, one below the carrier center frequency and one above the carrier center frequency, outside of which all emissions are attenuated at least 26 dB below the transmitter power.

The unwanted emission power shall be measured with a resolution bandwidth of at least 1% of the occupied bandwidth in the 1 MHz band immediately outside and adjacent to the channel edge of the equipment. Beyond the 1 MHz band immediately outside the channel edge of the equipment, a resolution bandwidth of 1 MHz shall be employed. A narrower resolution bandwidth is allowed to be used provided that the measured power is integrated over the full required measurement bandwidth of 1 MHz or 1% of the occupied bandwidth as applicable.

The power of any unwanted emissions measured from the channel edge of the equipment shall be attenuated below the transmitter power, P (dBW), as follows:

- a. for base station and subscriber equipment, other than mobile subscriber equipment, the attenuation shall not be less than  $43 + 10 \text{ Log}_{10} (p)$ , dB; and
- b. for mobile subscriber equipment, the attenuation shall not be less than  $43 + 10 \text{ Log}_{10} (p)$ , dB at the channel edges and  $55 + 10 \text{ Log}_{10} (p)$  at 5.5 MHz away and beyond the channel edges where p in (a) and (b) is the transmitter power measured in watts.

**MODES TESTED**

- LTE Band 2
- LTE Band 4
- LTE Band 7
- LTE Band 17

**RESULTS**

PASS

**Below 1G:**

**QPSK EIRP POWER FOR LTE BAND 2 (1.4MHZ BANDWIDTH)**

Test Results for Low Channel 1850.7MHz							
Frequency(MHz)	SG Level(dBm)	Cable Loss(dB)	Antenna Gain(dB)	Absolute Level(dBm)	Limit (dBm)	Margin(dBm)	Polarity
279.26	-59.35	1.81	19.2	-41.96	-13	-28.96	Horizontal
398.24	-60.28	1.82	19.31	-42.79	-13	-29.79	Vertical
294.79	-59.96	1.82	19.22	-42.56	-13	-29.56	Vertical
399.04	-59.31	1.81	19.24	-41.88	-13	-28.88	Horizontal
Test Results for Mid Channel 1880MHz							
222.32	-61.59	1.81	18.11	-45.29	-13	-32.29	Horizontal
279.26	-59.6	1.91	19.2	-42.31	-13	-29.31	Vertical
598.49	-60.21	1.91	19.34	-42.78	-13	-29.78	Vertical
719.21	-60.42	1.91	19.21	-43.12	-13	-30.12	Horizontal
Test Results for High Channel 1909.3MHz							
276.56	-57.96	1.91	19.2	-40.67	-13	-27.67	Horizontal
402.47	-57.31	1.92	19.33	-39.9	-13	-26.9	Vertical
563.57	-57.51	1.91	19.22	-40.2	-13	-27.2	Vertical
760.85	-57.52	1.91	19.21	-40.22	-13	-27.22	Horizontal

**Note:**

1. Pre-test tests all modes, only the worst mode data is recorded in the report
2. All other emissions more than 20dB below the limit

9.1 LTE BAND 2

**QPSK EIRP POWER FOR LTE BAND 2 (1.4MHZ BANDWIDTH)**

Test Results for Low Channel 1850.7MHz							
Frequency(MHz)	SG Level(dBm)	Cable Loss(dB)	Antenna Gain(dB)	Absolute Level(dBm)	Limit (dBm)	Margin(dBm)	Polarity
3701.4	-58.61	4.04	33.51	-29.14	-13	-16.14	Horizontal
3701.4	-59.34	4.04	33.51	-29.87	-13	-16.87	Vertical
5552.1	-56.98	5.24	35.84	-26.38	-13	-13.38	Vertical
5552.1	-57.31	5.24	35.84	-26.71	-13	-13.71	Horizontal
Test Results for Mid Channel 1880MHz							
3760	-58.31	4.04	33.56	-28.79	-13	-15.79	Horizontal
3760	-56.61	4.04	33.56	-27.09	-13	-14.09	Vertical
5640	-57.74	5.24	35.91	-27.07	-13	-14.07	Vertical
5640	-56.98	5.24	35.91	-26.31	-13	-13.31	Horizontal
Test Results for High Channel 1909.3MHz							
3818.6	-58.44	4.04	34.00	-28.48	-13	-15.48	Horizontal
3818.6	-57.62	4.04	34.00	-27.66	-13	-14.66	Vertical
5727.9	-57.14	5.24	36.04	-26.34	-13	-13.34	Vertical
5727.9	-57.70	5.24	36.04	-26.90	-13	-13.90	Horizontal

**QPSK EIRP POWER FOR LTE BAND 2 (20.0MHZ BANDWIDTH)**

Test Results for Low Channel 1860MHz							
Frequency(MHz)	SG Level(dBm)	Cable Loss(dB)	Antenna Gain(dB)	Absolute Level(dBm)	Limit (dBm)	Margin(dBm)	Polarity
3720	-56.06	4.07	33.54	-26.59	-13	-13.59	Horizontal
3720	-55.95	4.07	33.54	-26.48	-13	-13.48	Vertical
5580	-57.65	5.28	35.86	-27.07	-13	-14.07	Vertical
5580	-58.70	5.28	35.86	-28.12	-13	-15.12	Horizontal
Test Results for Mid Channel 1880MHz							
3760	-56.98	4.04	33.56	-27.46	-13	-14.46	Horizontal
3760	-57.41	4.04	33.56	-27.89	-13	-14.89	Vertical
5640	-58.61	5.24	35.91	-27.94	-13	-14.94	Vertical
5640	-57.31	5.24	35.91	-26.64	-13	-13.64	Horizontal
Test Results for High Channel 1900MHz							
3800	-57.41	4.04	34.00	-27.45	-13	-14.45	Horizontal
3800	-56.98	4.04	34.00	-27.02	-13	-14.02	Vertical
5700	-57.41	5.24	36.04	-26.61	-13	-13.61	Vertical
5700	-58.62	5.24	36.04	-27.82	-13	-14.82	Horizontal

Note: P<sub>Mea</sub>(dBm)= Power(dBm)+ ARpl (dBm)

. Over Limit= : P<sub>Mea</sub>(dBm)-Limit(dBm)

. We test both H direction and V direction, recorded worst case direction.

9.2 LTE BAND 4

**QPSK EIRP POWER FOR LTE BAND 4 (1.4MHZ BANDWIDTH)**

Test Results for Low Channel 1710.7MHz							
Frequency(MHz)	SG Level(dBm)	Cable Loss(dB)	Antenna Gain(dB)	Absolute Level(dBm)	Limit (dBm)	Margin(dBm)	Polarity
3421.4	-53.64	4.02	29.80	-27.86	-13	-14.86	Horizontal
3421.4	-54.31	4.02	29.80	-28.53	-13	-15.53	Vertical
5132.1	-57.41	5.24	35.84	-26.81	-13	-13.81	Vertical
5132.1	-58.73	5.24	35.84	-28.13	-13	-15.13	Horizontal
Test Results for Mid Channel 1732.5MHz							
3465	-51.35	4.03	30.00	-25.38	-13	-12.38	Horizontal
3465	-52.07	4.03	30.00	-26.10	-13	-13.10	Vertical
5197.5	-56.41	5.25	35.86	-25.80	-13	-12.80	Vertical
5197.5	-56.70	5.25	35.86	-26.09	-13	-13.09	Horizontal
Test Results for High Channel 1754.3MHz							
3508.6	-54.41	4.05	30.01	-28.45	-13	-15.45	Horizontal
3508.6	-56.17	4.05	30.01	-30.21	-13	-17.21	Vertical
5262.9	-56.52	5.26	35.86	-25.92	-13	-12.92	Vertical
5262.9	-55.93	5.26	35.86	-25.33	-13	-12.33	Horizontal

**QPSK EIRP POWER FOR LTE BAND 4 (20.0MHZ BANDWIDTH)**

Test Results for Low Channel 1720MHz							
Frequency(MHz)	SG Level(dBm)	Cable Loss(dB)	Antenna Gain(dB)	Absolute Level(dBm)	Limit (dBm)	Margin(dBm)	Polarity
3440	-56.31	4.02	29.80	-30.53	-13	-17.53	Horizontal
3440	-54.65	4.02	29.80	-28.87	-13	-15.87	Vertical
5160	-57.40	5.24	35.84	-26.80	-13	-13.80	Vertical
5160	-58.61	5.24	35.84	-28.01	-13	-15.01	Horizontal
Test Results for Mid Channel 1732.5MHz							
3465	-53.62	4.03	30.00	-27.65	-13	-14.65	Horizontal
3465	-54.84	4.03	30.00	-28.87	-13	-15.87	Vertical
5197.5	-56.95	5.25	35.86	-26.34	-13	-13.34	Vertical
5197.5	-57.44	5.25	35.86	-26.83	-13	-13.83	Horizontal
Test Results for High Channel 1745MHz							
3490	-53.62	2.91	27.68	-28.85	-13	-15.85	Horizontal
3490	-56.98	2.91	27.68	-32.21	-13	-19.21	Vertical
5235	-57.62	5.26	35.86	-27.02	-13	-14.02	Vertical
5235	-58.31	5.26	35.86	-27.71	-13	-14.71	Horizontal

Note: P<sub>Mea</sub>(dBm)= Power(dBm)+ ARpl (dBm)

Over Limit= : P<sub>Mea</sub>(dBm)-Limit(dBm)

We test both H direction and V direction, recorded worst case direction.



9.3 LTE BAND 7

**QPSK EIRP POWER FOR LTE BAND 7 (5.0MHZ BANDWIDTH)**

Test Results for Low Channel 2502.5MHz							
Frequency(MHz)	SG Level(dBm)	Cable Loss(dB)	Antenna Gain(dB)	Absolute Level(dBm)	Limit (dBm)	Margin(dBm)	Polarity
5005	-83.41	5.23	35.81	-52.83	-25.00	-27.83	Horizontal
5005	-82.70	5.23	35.81	-52.12	-25.00	-27.12	Vertical
7507.5	-81.71	5.67	36.85	-50.53	-25.00	-25.53	Vertical
7507.5	-81.30	5.67	36.85	-50.12	-25.00	-25.12	Horizontal
Test Results for Mid Channel 2535MHz							
5070	-80.10	5.23	35.82	-49.51	-25.00	-24.51	Horizontal
5070	-81.19	5.23	35.82	-50.60	-25.00	-25.60	Vertical
7605	-81.74	5.67	36.85	-50.56	-25.00	-25.56	Vertical
7605	-82.22	5.67	36.85	-51.04	-25.00	-26.04	Horizontal
Test Results for High Channel 2567.5MHz							
5135	-84.31	5.24	35.83	-53.72	-25.00	-28.72	Horizontal
5135	-81.87	5.24	35.83	-51.28	-25.00	-26.28	Vertical
7702.5	-82.70	5.68	36.87	-51.51	-25.00	-26.51	Vertical
7702.5	-83.04	5.68	36.87	-51.85	-25.00	-26.85	Horizontal

**QPSK EIRP POWER FOR LTE BAND 7 (20.0MHZ BANDWIDTH)**

Test Results for Low Channel 2510MHz							
Frequency(MHz)	SG Level(dBm)	Cable Loss(dB)	Antenna Gain(dB)	Absolute Level(dBm)	Limit (dBm)	Margin(dBm)	Polarity
5020	-81.07	5.23	35.82	-50.48	-25.00	-25.48	Horizontal
5020	-80.50	5.23	35.82	-49.91	-25.00	-24.91	Vertical
7530	-81.46	5.67	36.86	-50.27	-25.00	-25.27	Vertical
7530	-81.49	5.67	36.86	-50.30	-25.00	-25.30	Horizontal
Test Results for Mid Channel 2535MHz							
5070	-82.94	5.23	35.82	-52.35	-25.00	-27.35	Horizontal
5070	-82.27	5.23	35.82	-51.68	-25.00	-26.68	Vertical
7605	-82.07	5.67	36.85	-50.89	-25.00	-25.89	Vertical
7605	-83.61	5.67	36.85	-52.43	-25.00	-27.43	Horizontal
Test Results for High Channel 2560MHz							
5120	-80.79	5.24	35.83	-50.20	-25.00	-25.20	Horizontal
5120	-80.74	5.24	35.83	-50.15	-25.00	-25.15	Vertical
7680	-81.06	5.70	36.88	-49.88	-25.00	-24.88	Vertical
7680	-80.46	5.70	36.88	-49.28	-25.00	-24.28	Horizontal

Note: P<sub>Mea</sub>(dBm)= Power(dBm)+ ARpl (dBm)  
 . Over Limit= : P<sub>Mea</sub>(dBm)-Limit(dBm)  
 . We test both H direction and V direction, recorded worst case direction.

9.4 LTE BAND 17

**QPSK EIRP POWER FOR LTE BAND 17 (5MHZ BANDWIDTH)**

Test Results for Low Channel 706.5MHz							
Frequency(MHz)	SG Level(dBm)	Cable Loss(dB)	Antenna Gain(dB)	Absolute Level(dBm)	Limit (dBm)	Margin(dBm)	Polarity
1413	-52.40	2.61	27.28	-27.73	-13	-14.73	Horizontal
1413	-53.31	2.61	27.28	-28.64	-13	-15.64	Vertical
2119.5	-52.76	2.87	27.59	-28.04	-13	-15.04	Vertical
2119.5	-52.42	2.87	27.59	-27.70	-13	-14.70	Horizontal
Test Results For Mid Channel 710MHz							
1420	-51.87	2.62	27.30	-27.19	-13	-14.19	Horizontal
1420	-53.73	2.62	27.30	-29.05	-13	-16.05	Vertical
2130	-54.45	2.87	27.62	-29.70	-13	-16.70	Vertical
2130	-57.10	2.87	27.62	-32.35	-13	-19.35	Horizontal
Test Results for High Channel 713.5MHz							
1427	-54.03	2.66	27.28	-29.41	-13	-16.41	Horizontal
1427	-55.48	2.66	27.28	-30.86	-13	-17.86	Vertical
2140.5	-52.60	2.88	27.60	-27.88	-13	-14.88	Vertical
2140.5	-51.30	2.88	27.60	-26.58	-13	-13.58	Horizontal

**QPSK EIRP POWER FOR LTE BAND 17 (10MHZ BANDWIDTH)**

Test Results for Low Channel 709MHz							
Frequency(MHz)	SG Level(dBm)	Cable Loss(dB)	Antenna Gain(dB)	Absolute Level(dBm)	Limit (dBm)	Margin(dBm)	Polarity
1418	-54.93	2.62	27.30	-30.25	-13	-17.25	Horizontal
1418	-52.79	2.62	27.30	-28.11	-13	-15.11	Vertical
2127	-53.96	2.87	27.62	-29.21	-13	-16.21	Vertical
2127	-57.05	2.87	27.62	-32.30	-13	-19.30	Horizontal
Test Results for Mid Channel 710MHz							
1420	-54.49	2.62	27.30	-29.81	-13	-16.81	Horizontal
1420	-52.00	2.62	27.30	-27.32	-13	-14.32	Vertical
2130	-56.36	2.87	27.62	-31.61	-13	-18.61	Vertical
2130	-51.94	2.87	27.62	-27.19	-13	-14.19	Horizontal
Test Results for High Channel 711MHz							
1422	-52.98	2.62	27.30	-28.30	-13	-15.30	Horizontal
1422	-53.59	2.62	27.30	-28.91	-13	-15.91	Vertical
2133	-52.54	2.87	27.62	-27.79	-13	-14.79	Vertical
2133	-55.49	2.87	27.62	-30.74	-13	-17.74	Horizontal

Note: P<sub>Mea</sub>(dBm)= Power(dBm)+ AR<sub>pl</sub> (dBm)

. Over Limit= : P<sub>Mea</sub>(dBm)-Limit(dBm)

. We test both H direction and V direction, recorded worst case direction.

## 10. FREQUENCY STABILITY

### RULE PART(S)

FCC: §2.1055, §22.355, §24.235, §27.54

### LIMITS

§22.355 - The carrier frequency shall not depart from the reference frequency in excess of  $\pm 2.5$  ppm for mobile stations.

§24.235 - The frequency stability shall be sufficient to ensure that the fundamental emission stays within the authorized frequency block.

### TEST PROCEDURE

Use CMW 500 with Frequency Error measurement capability.

Temp. =  $-30^{\circ}$  to  $+50^{\circ}$ C

Voltage = low voltage, DC 3.4V, Normal, DC 3.8V and High voltage, DC 4.4V.

### Frequency Stability vs Temperature:

The EUT is placed inside a temperature chamber. The temperature is set to  $-30^{\circ}$ C and allowed to stabilize. After sufficient soak time, the transmitting frequency error is measured. The temperature is increased by 10 degrees, allowed to stabilize and soak, and then the measurement is repeated. This is repeated until  $+50^{\circ}$ C is reached.

### Frequency Stability vs Voltage:

The peak frequency error is recorded (worst-case).

### MODES TESTED

LTE Band 2

LTE Band 4

LTE Band 7

LTE Band 17

## RESULTS

See the following pages.

10.1 LTE BAND 2

QPSK, (20MHz BANDWIDTH)

**Frequency error vs. Voltage**

Voltage [Vdc]	Frequency [MHz]	Frequency* Error[Hz]	Frequency Error[ppm]	Limit [ppm]
<b>BAND 2 QPSK, (CH 18900 RB size 100 RB Offset 0 20MHz BANDWIDTH)</b>				
3.4	1880	-13.1	-0.006968	2.5
3.8	1880	-13.2	-0.007021	2.5
4.4	1880	-12.7	-0.006755	2.5

**Frequency error vs. Temperature**

Temperature [° C]	Frequency [MHz]	Frequency* Error[Hz]	Frequency Error[ppm]	Limit [ppm]
<b>BAND 2 QPSK, (CH 18900 RB size 100 RB Offset 0 20MHz BANDWIDTH)</b>				
Normal (25C)	1880	-13.1	-0.006968	2.5
Extreme (50C)	1880	-11	-0.005851	2.5
Extreme (40C)	1880	-11.1	-0.005904	2.5
Extreme (30C)	1880	-13.2	-0.007021	2.5
Extreme (10C)	1880	-13.7	-0.007287	2.5
Extreme (0C)	1880	-13.6	-0.007234	2.5
Extreme (-10C)	1880	-15.3	-0.008138	2.5
Extreme (-20C)	1880	-14.5	-0.007713	2.5
Extreme (-30C)	1880	-15.2	-0.008085	2.5

**16QAM, (20MHz BANDWIDTH)**

**Frequency error vs. Voltage**

Voltage [Vdc]	Frequency [MHz]	Frequency* Error[Hz]	Frequency Error[ppm]	Limit [ppm]
<b>BAND 2 16QAM, (CH 18900 RB size 100 RB Offset 0 20MHz BANDWIDTH)</b>				
3.4	1880	-19.0	-0.010106	2.5
3.8	1880	-15.4	-0.008191	2.5
4.4	1880	-18.6	-0.009894	2.5

**Frequency error vs. Temperature**

Temperature [° C]	Frequency [MHz]	Frequency* Error[Hz]	Frequency Error[ppm]	Limit [ppm]
<b>BAND 2 16QAM, (CH 18900 RB size 100 RB Offset 0 20MHz BANDWIDTH)</b>				
Normal (25C)	1880	-19.3	-0.010266	2.5
Extreme (50C)	1880	-20.5	-0.010904	2.5
Extreme (40C)	1880	-20.1	-0.010691	2.5
Extreme (30C)	1880	-18.6	-0.009894	2.5
Extreme (10C)	1880	-19.2	-0.010213	2.5
Extreme (0C)	1880	-18.1	-0.009628	2.5
Extreme (-10C)	1880	-17.5	-0.009309	2.5
Extreme (-20C)	1880	-17.3	-0.009202	2.5
Extreme (-30C)	1880	-16.6	-0.008830	2.5

\*Note: Frequency error measurements were made by using the build-in capability of the Wireless Communication Test Set.

10.2 LTE BAND 4

QPSK, (10MHz BANDWIDTH)

**Frequency error vs. Voltage**

Voltage [Vdc]	Frequency [MHz]	Frequency* Error[Hz]	Frequency Error[ppm]	Limit [ppm]
<b>BAND 4 QPSK, (CH 20175 RB size 100 RB Offset 0 20MHz BANDWIDTH)</b>				
3.4	1732.5	-14.9	-0.008600	2.5
3.8	1732.5	-14.9	-0.008600	2.5
4.4	1732.5	-15.0	-0.008658	2.5

**Frequency error vs. Temperature**

Temperature [°C]	Frequency [MHz]	Frequency* Error[Hz]	Frequency Error[ppm]	Limit [ppm]
<b>BAND 4 QPSK, (CH 20175 RB size 100 RB Offset 0 20MHz BANDWIDTH)</b>				
Normal (25C)	1732.5	-11.8	-0.006811	2.5
Extreme (50C)	1732.5	-13.5	-0.007792	2.5
Extreme (40C)	1732.5	-13.2	-0.007619	2.5
Extreme (30C)	1732.5	-13.2	-0.007619	2.5
Extreme (10C)	1732.5	-11.5	-0.006638	2.5
Extreme (0C)	1732.5	-10.7	-0.006176	2.5
Extreme (-10C)	1732.5	-11	-0.006349	2.5
Extreme (-20C)	1732.5	-15.2	-0.008773	2.5
Extreme (-30C)	1732.5	-13.6	-0.007850	2.5

**16QAM, (20MHz BANDWIDTH)**

**Frequency error vs. Voltage**

Voltage [Vdc]	Frequency [MHz]	Frequency* Error[Hz]	Frequency Error[ppm]	Limit [ppm]
<b>BAND 4 16QAM, (CH 20175 RB size 100 RB Offset 0 20MHz BANDWIDTH)</b>				
3.4	1732.5	-12.6	-0.007273	2.5
3.8	1732.5	-13.3	-0.007677	2.5
4.4	1732.5	-13.1	-0.007561	2.5

**Frequency error vs. Temperature**

Temperature [°C]	Frequency [MHz]	Frequency* Error[Hz]	Frequency Error[ppm]	Limit [ppm]
<b>BAND 4 16QAM, (CH 20175 RB size 100 RB Offset 0 20MHz BANDWIDTH)</b>				
Normal (25C)	1732.5	-13.2	-0.007619	2.5
Extreme (50C)	1732.5	-10.2	-0.005887	2.5
Extreme (40C)	1732.5	-10.7	-0.006176	2.5
Extreme (30C)	1732.5	-12	-0.006926	2.5
Extreme (10C)	1732.5	-12.6	-0.007273	2.5
Extreme (0C)	1732.5	-12.3	-0.007100	2.5
Extreme (-10C)	1732.5	-10.5	-0.006061	2.5
Extreme (-20C)	1732.5	-12.1	-0.006984	2.5
Extreme (-30C)	1732.5	-12	-0.006926	2.5

**\*Note:** Frequency error measurements were made by using the build-in capability of the Wireless Communication Test Set.

10.3 LTE BAND 7

QPSK, (20MHz BANDWIDTH)

**Frequency error vs. Voltage**

Voltage [Vdc]	Frequency [MHz]	Frequency* Error[Hz]	Frequency Error[ppm]	Limit [ppm]
<b>BAND 7 QPSK, (CH 21100 RB size 100 RB Offset 0 20MHz BANDWIDTH)</b>				
3.4	2535	-22.0	-0.008679	2.5
3.8	2535	-22.4	-0.008836	2.5
4.4	2535	-22.8	-0.008994	2.5

**Frequency error vs. Temperature**

Temperature [° C]	Frequency [MHz]	Frequency* Error[Hz]	Frequency Error[ppm]	Limit [ppm]
<b>BAND 7 QPSK, (CH 21100 RB size 100 RB Offset 0 20MHz BANDWIDTH)</b>				
Normal (25C)	2535	-22.7	-0.008955	2.5
Extreme (50C)	2535	-25.5	-0.010059	2.5
Extreme (40C)	2535	-27.6	-0.010888	2.5
Extreme (30C)	2535	-22.6	-0.008915	2.5
Extreme (10C)	2535	-22.2	-0.008757	2.5
Extreme (0C)	2535	-21.3	-0.008402	2.5
Extreme (-10C)	2535	-24.5	-0.009665	2.5
Extreme (-20C)	2535	-23	-0.009073	2.5
Extreme (-30C)	2535	-26.1	-0.010296	2.5



**16QAM, (20MHz BANDWIDTH)**

**Frequency error vs. Voltage**

Voltage [Vdc]	Frequency [MHz]	Frequency* Error[Hz]	Frequency Error[ppm]	Limit [ppm]
<b>BAND 7 16QAM, (CH 21100 RB size 100 RB Offset 0 20MHz BANDWIDTH)</b>				
3.4	2535	-23.9	-0.009428	2.5
3.8	2535	-24.3	-0.009586	2.5
4.4	2535	-24.3	-0.009586	2.5

**Frequency error vs. Temperature**

Temperature [° C]	Frequency [MHz]	Frequency* Error[Hz]	Frequency Error[ppm]	Limit [ppm]
<b>BAND 7 16QAM, (CH 21100 RB size 100 RB Offset 0 20MHz BANDWIDTH)</b>				
Normal (25C)	2535	-23.6	-0.009310	2.5
Extreme (50C)	2535	-25.1	-0.009901	2.5
Extreme (40C)	2535	-26.6	-0.010493	2.5
Extreme (30C)	2535	-23.7	-0.009349	2.5
Extreme (10C)	2535	-23.8	-0.009389	2.5
Extreme (0C)	2535	-24.5	-0.009665	2.5
Extreme (-10C)	2535	-25.3	-0.009980	2.5
Extreme (-20C)	2535	-24.9	-0.009822	2.5
Extreme (-30C)	2535	-25.6	-0.010099	2.5

**\*Note:** Frequency error measurements were made by using the build-in capability of the Wireless Communication Test Set.

10.4 LTE BAND 17

QPSK, (10MHz BANDWIDTH)

**Frequency error vs. Voltage**

Voltage [Vdc]	Frequency [MHz]	Frequency* Error[Hz]	Frequency Error[ppm]	Limit [ppm]
<b>BAND 17 QPSK, (CH 23790 RB size 50 RB Offset 0 10MHz BANDWIDTH)</b>				
3.4	710.0	-7.5	-0.010563	2.5
3.8	710.0	-6.9	-0.009718	2.5
4.4	710.0	-6.7	-0.009437	2.5

**Frequency error vs. Temperature**

Temperature [° C]	Frequency [MHz]	Frequency* Error[Hz]	Frequency Error[ppm]	Limit [ppm]
<b>BAND 17 QPSK, (CH 23790 RB size 50 RB Offset 0 10MHz BANDWIDTH)</b>				
Normal (25C)	710.0	-7	-0.009859	2.5
Extreme (50C)	710.0	-7.5	-0.010563	2.5
Extreme (40C)	710.0	-7	-0.009859	2.5
Extreme (30C)	710.0	-7.8	-0.010986	2.5
Extreme (10C)	710.0	-7.7	-0.010845	2.5
Extreme (0C)	710.0	-7.8	-0.010986	2.5
Extreme (-10C)	710.0	-6.9	-0.009718	2.5
Extreme (-20C)	710.0	-7.4	-0.010423	2.5
Extreme (-30C)	710.0	-7.3	-0.010282	2.5

**16QAM, (10MHz BANDWIDTH)**

**Frequency error vs. Voltage**

Voltage [Vdc]	Frequency [MHz]	Frequency* Error[Hz]	Frequency Error[ppm]	Limit [ppm]
<b>BAND 17 16QAM, (CH 23790 RB size 50 RB Offset 0 10MHz BANDWIDTH)</b>				
3.4	710.0	-8.8	-0.012394	2.5
3.8	710.0	-9.1	-0.012817	2.5
4.4	710.0	-8.6	-0.012113	2.5

**Frequency error vs. Temperature**

Temperature [° C]	Frequency [MHz]	Frequency* Error[Hz]	Frequency Error[ppm]	Limit [ppm]
<b>BAND 17 QPSK, (CH 23790 RB size 50 RB Offset 0 10MHz BANDWIDTH)</b>				
Normal (25C)	710.0	-8.6	-0.012113	2.5
Extreme (50C)	710.0	-9.7	-0.013662	2.5
Extreme (40C)	710.0	-9.2	-0.012958	2.5
Extreme (30C)	710.0	-8.7	-0.012254	2.5
Extreme (10C)	710.0	-8.8	-0.012394	2.5
Extreme (0C)	710.0	-9.2	-0.012958	2.5
Extreme (-10C)	710.0	-9.5	-0.013380	2.5
Extreme (-20C)	710.0	-9	-0.012676	2.5
Extreme (-30C)	710.0	-9.4	-0.013239	2.5

**\*Note:** Frequency error measurements were made by using the build-in capability of the Wireless Communication Test Set.

## 11. Peak-to-Average Ratio

### 11.1 Description of the PAR Measurement

The peak-to-average ratio (PAR) of the transmission may not exceed 13 dB.

### 11.2 Measuring Instruments

See list of measuring instruments of this test report.

### 11.3 Test Procedures

1. The EUT was connected to Spectrum Analyzer and Base Station via power divider.
2. The RF output of EUT was connected to the spectrum analyzer by RF cable and attenuator. The path loss was compensated to the results for each measurement.
3. For GSM/EGPRS operating modes:
  - a. Set the RBW = 1MHz, VBW = 1MHz, Peak detector in spectrum analyzer.
  - b. Set EUT in maximum power output, and triggered the burst signal.
  - c. Measured respectively the Peak level and Mean level, and the deviation was recorded as Peak to Average Ratio.
4. For UMTS operating modes:
  - a. Set the CCDF (Complementary Cumulative Distribution Function) option in spectrum analyzer.
  - b. The highest RF powers were measured and recorded the maximum PAPR level associated with a probability of 0.1 %.

### 11.4 Test Setup

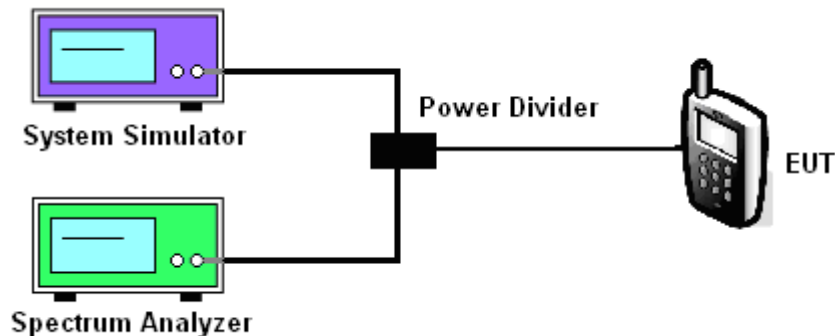

#### MODES TESTED

- LTE Band 2
- LTE Band 4
- LTE Band 7
- LTE Band 17

Test data reference attachment.

----END OF REPORT----