

---

# FCC Test Report

---

Report No.: AGC01680170434FE01

**FCC ID** : ZRQ-KB3  
**APPLICATION PURPOSE** : Original Equipment  
**PRODUCT DESIGNATION** : Mini Keyboard  
**BRAND NAME** : Penclic  
**MODEL NAME** : KB3  
**CLIENT** : Penclic AB  
**DATE OF ISSUE** : Jun.20, 2017  
**STANDARD(S)** : FCC Part 15 Subpart B  
**REPORT VERSION** : V1.0

Attestation of Global Compliance (Shenzhen) Co., Ltd



**CAUTION:**

This report shall not be reproduced except in full without the written permission of the test laboratory and shall not be quoted out of context.



**Report Revise Record**

<b>Report Version</b>	<b>Revise Time</b>	<b>Issued Date</b>	<b>Valid Version</b>	<b>Notes</b>
V1.0	/	Jun.20, 2017	Valid	Original Report

**TABLE OF CONTENTS**

- 1. VERIFICATION OF CONFORMITY ..... 4**
- 2. SYSTEM DESCRIPTION ..... 5**
- 3. MEASUREMENT UNCERTAINTY ..... 5**
- 4. PRODUCT INFORMATION ..... 6**
- 5. SUPPORT EQUIPMENT ..... 7**
- 6. TEST FACILITY ..... 8**
- 7. TEST EQUIPMENT LIST ..... 8**
- 8. FCCLINE CONDUCTED EMISSION TEST ..... 9**
  - 8.1. LIMITS OF LINE CONDUCTED EMISSION TEST ..... 9
  - 8.2. BLOCK DIAGRAM OF TEST SETUP ..... 9
  - 8.3. PROCEDURE OF LINE CONDUCTED EMISSION TEST ..... 10
  - 8.4. TEST RESULT OF LINE CONDUCTED EMISSION TEST ..... 11
- 9. FCC RADIATED EMISSION TEST ..... 13**
  - 9.1. LIMITS OF RADIATED EMISSION TEST ..... 13
  - 9.2. BLOCK DIAGRAM OF TEST SETUP ..... 14
  - 9.3. PROCEDURE OF RADIATED EMISSION TEST ..... 15
  - 9.4. TEST RESULT OF RADIATED EMISSION TEST ..... 16
- APPENDIX A: PHOTOGRAPHS OF TEST SETUP ..... 20**
- APPENDIX B: PHOTOGRAPHS OF EUT ..... 22**

## 1. VERIFICATION OF CONFORMITY

<b>Applicant</b>	Penclic AB
<b>Address</b>	Vendev. 90, Danderyd, Sweden, 182 32
<b>Manufacturer</b>	Shenzhen Hastech Industries Co., Ltd.
<b>Address</b>	3F/4F A1 BLDG, 1F/2F A2 BLDG, G AREA, DEMOCRACY WEST INDUSTRY PARK, SHAJING TOWN, BAOAN DISTRICT, SHENZHEN, CHINA
<b>Product Designation</b>	Mini Keyboard
<b>Brand Name</b>	Penclic
<b>Test Model</b>	KB3
<b>Date of test</b>	Apr.28, 2017 to May 06, 2017
<b>Deviation</b>	None
<b>Condition of Test Sample</b>	Normal
<b>Report Template</b>	AGCRT-US-IT/AC

The above equipment was tested by Dongguan Precise Testing Service Co., Ltd. for compliance with the requirements set forth in the FCC Rules and Regulations Part 15, the measurement procedure according to ANSI C63.4:2014. This said equipment in the configuration described in this report shows the maximum emission levels emanating from equipment are within the compliance requirements.

The test results of this report relate only to the tested sample identified in this report.

Tested By Henry Zhang  
Henry Zhang(Zhang Zhuorui) May 06, 2017

Reviewed By Forrest Lei  
Forrest Lei(Lei Yonggang) Jun.20, 2017

Approved By Solger Zhang  
Solger Zhang(Zhang Hongyi)  
Authorized Officer Jun.20, 2017

## 2. SYSTEM DESCRIPTION

### EUT set up procedure:

1. Connect the EUT with PC.
2. Make sure the EUT operates normally during the test.

### Test Mode

TEST MODE DESCRIPTION		
NO.	TEST MODE DESCRIPTION	WORST
1	Data Transmission(USB)	V
Note: V means EMI worst mode		

## 3. MEASUREMENT UNCERTAINTY

The uncertainty is calculated using the methods suggested in the “Guide to the Expression of Uncertainty in Measurement” (GUM) published by ISO.

Conducted measurement: +/- 2.75dB

Radiated measurement: +/- 3.2dB

### Summary Of Test Results

FCC Rules	Description Of Test	Result
§15.107	Conduction Emission	Compliant
§15.109	Radiated Emission	Compliant

**4. PRODUCT INFORMATION**

<b>Housing Type</b>	Plastic and metal
<b>Voltage</b>	DC 3.7V by battery

**I/O Port Information (Applicable Not Applicable)**

<b>I/O Port of EUT</b>			
<b>I/O Port Type</b>	<b>Q'TY</b>	<b>Cable</b>	<b>Tested with</b>
USB Port	1	0	1

## 5. SUPPORT EQUIPMENT

Device Type	Manufacturer	Model Name	Serial No.	Power Cable
PC	SONY	E1412AYCW	A.E	N/A
PC Adapter	SONY	VGP-AC19V36	A.E	3m unshielded

**Note:** All the above equipment/cables were placed in worse case positions to maximize emission signals during emission test.

## 6. TEST FACILITY

<b>Site</b>	Dongguan Precise Testing Service Co., Ltd.
<b>Location</b>	Building D, Baoding Technology Park, Guangming Road2,Dongcheng District, Dongguan, Guangdong, China,
<b>FCC Registration No.</b>	371540
<b>Description</b>	The test site is constructed and calibrated to meet the FCC requirements in documents ANSI C63.4:2014.

## 7. TEST EQUIPMENT LIST

TEST EQUIPMENT LIST					
Name of Equipment	Manufacturer	Model Number	Serial Number	Last Calibration	Due Calibration
EMI Test Receiver	ROHDE & SCHWARZBECK	ESCI	101417	July 4, 2016	July 3, 2017
Trilog Broadband Antenna (25M-1GHz)	SCHWARZBECK	VULB9160	9160-3355	July 4, 2016	July 3, 2017
Horn Antenna (1G-18GHz)	SCHWARZBECK	BBHA9120D	9120D-1246	July 11, 2016	July 10, 2017
Signal Amplifier	SCHWARZBECK	BBV 9475	9745-0013	July 4, 2016	July 3, 2017
RF Cable	SCHWARZBECK	AK9515E	96221	July 4, 2016	July 3, 2017
3m Anechoic Chamber	CHENGYU	966	PTS-001	June 6, 2016	June 5, 2017
MULTI-DEVICE Positioning Controller	MAX-FULL	MF-7802	MF780208339	N/A	N/A
Active loop antenna (9K-30MHz)	SCHWARZBECK	FMZB1519	1519-038	June 6, 2016	June 5, 2017
Spectrum analyzer	AGILENT	E4407B	MY46185649	June 6, 2016	June 5, 2017
Spectrum Analyzer	AGILENT	E4411B	MY4511453	July 4, 2016	July 3, 2017
Signal Amplifier	SCHWARZBECK	BBV 9718	9718-269	July 4, 2016	July 3, 2017
RF Cable	SCHWARZBECK	AK9515H	96220	July 4, 2016	July 3, 2017
Artificial Mains Network	NARDA	L2-16B	000WX31025	July 8, 2016	July 7, 2017
Artificial Mains Network (AUX)	NARDA	L2-16B	000WX31026	July 8, 2016	July 7, 2017
RF Cable	SCHWARZBECK	AK9515E	96222	July 4, 2016	July 3, 2017
Shielded Room	CHENGYU	843	PTS-002	June 6, 2016	June 5, 2017
Conduction Cable	MXT	SE1	S003	June 6, 2016	June 5, 2017



**8. FCCLINE CONDUCTED EMISSION TEST**

**8.1. LIMITS OF LINE CONDUCTED EMISSION TEST**

Frequency	Maximum RF Line Voltage	
	Q.P.( dBuV)	Average( dBuV)
150kHz-500kHz	66-56	56-46
500kHz-5MHz	56	46
5MHz-30MHz	60	50

**Note:**

1. The lower limit shall apply at the transition frequency.
2. The limit decreases linearly with the logarithm of the frequency in the range 0.15 MHz to 0.50MHz.

**8.2. BLOCK DIAGRAM OF TEST SETUP**

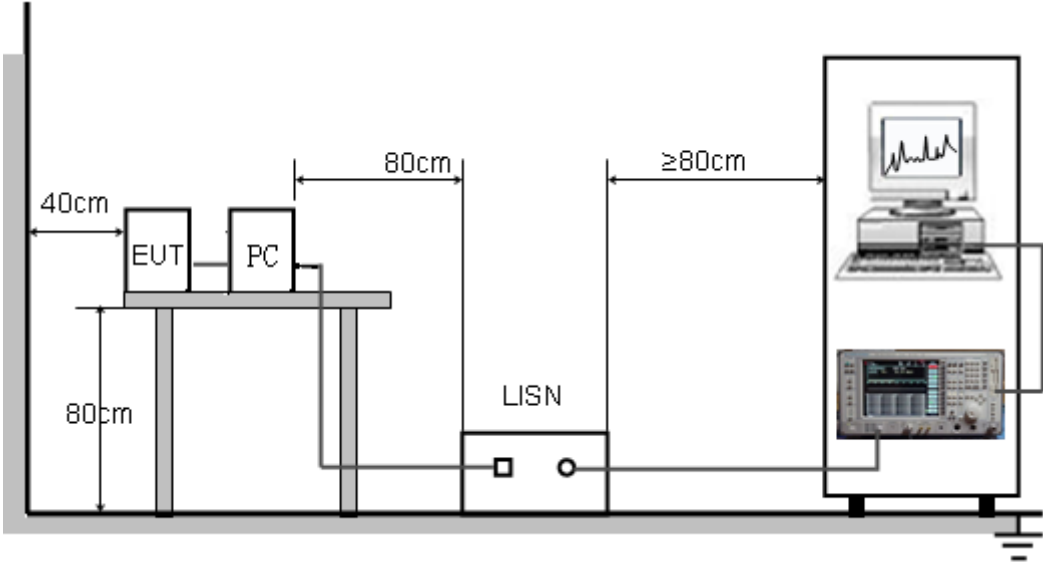

### 8.3. PROCEDURE OF LINE CONDUCTED EMISSION TEST

- (1) The equipment was set up as per the test configuration to simulate typical actual usage per the user's manual. When the EUT is a tabletop system, a wooden table with a height of 0.8 meters is used and is placed on the ground plane as per ANSI C63.4 (see Test Facility for the dimensions of the ground plane used). When the EUT is a floor-standing equipment, it is placed on the ground plane which has a 3-12 mm non-conductive covering to insulate the EUT from the ground plane.
- (2) Support equipment, if needed, was placed as per ANSI C63.4.
- (3) All I/O cables were positioned to simulate typical actual usage as per ANSI C63.4.
- (4) The EUT received charging voltage by adapter which receive AC120V/60Hz power from a LISN.
- (5) The EUT test program was started. Emissions were measured on each current carrying line of the EUT using a spectrum Analyzer / Receiver connected to the LISN powering the EUT. The LISN has two monitoring points: Line 1 (Hot Side) and Line 2 (Neutral Side). Two scans were taken: one with Line 1 connected to Analyzer / Receiver and Line 2 connected to a 50 ohm load; the second scan had Line 1 connected to a 50 ohm load and Line 2 connected to the Analyzer / Receiver.
- (6) Analyzer / Receiver scanned from 150 kHz to 30MHz for emissions in each of the test modes.
- (7) During the above scans, the emissions were maximized by cable manipulation.
- (8) A scan was taken on both power lines, Line 1 and Line 2, recording at least the six highest emissions.
- (9) Emission frequency and amplitude were recorded into a computer in which correction factors were used to calculate the emission level and compare reading to the applicable limit. If EUT emission level was less -2dB to the A.V. limit in Peak mode, then the emission signal was re-checked using Q.P and Average detector.

The test data of the worst case condition (mode 1) was reported on the Summary Data page.

**8.4. TEST RESULT OF LINE CONDUCTED EMISSION TEST**  
 LINE CONDUCTED EMISSION TEST-L

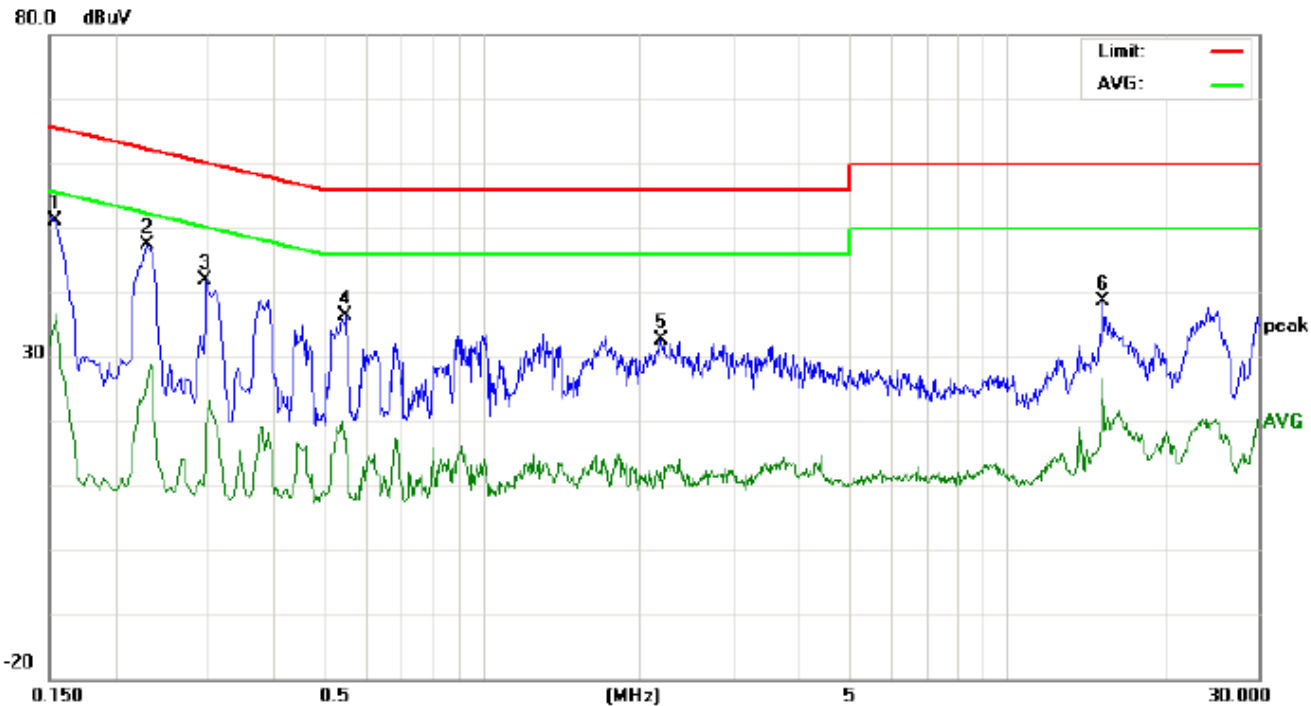

Site: Conduction Phase: *L1* Temperature: 26  
 Limit: FCC Class B Conduction(QP) Power: Humidity: 60 %  
 EUT:Mini Keyboard  
 M/N:KB3  
 Mode:Data Transmission  
 Note:

No.	Freq. (MHz)	Reading_Level (dBuV)			Correct Factor (dB)	Measurement (dBuV)			Limit (dBuV)		Margin (dB)		P/F	Comment
		Peak	QP	AVG		Peak	QP	AVG	QP	AVG	QP	AVG		
1	0.1547	41.67		21.69	10.17	51.84		31.86	65.74	55.74	-13.90	-23.88	P	
2	0.2300	37.18		15.84	10.25	47.43		26.09	62.45	52.45	-15.02	-26.36	P	
3	0.2979	31.69		9.07	10.29	41.98		19.36	60.30	50.30	-18.32	-30.94	P	
4	0.5500	26.09		6.42	10.35	36.44		16.77	56.00	46.00	-19.56	-29.23	P	
5	2.1939	22.40		1.81	10.30	32.70		12.11	56.00	46.00	-23.30	-33.89	P	
6	15.1898	28.57		16.53	10.12	38.69		26.65	60.00	50.00	-21.31	-23.35	P	

LINE CONDUCTED EMISSION TEST-N

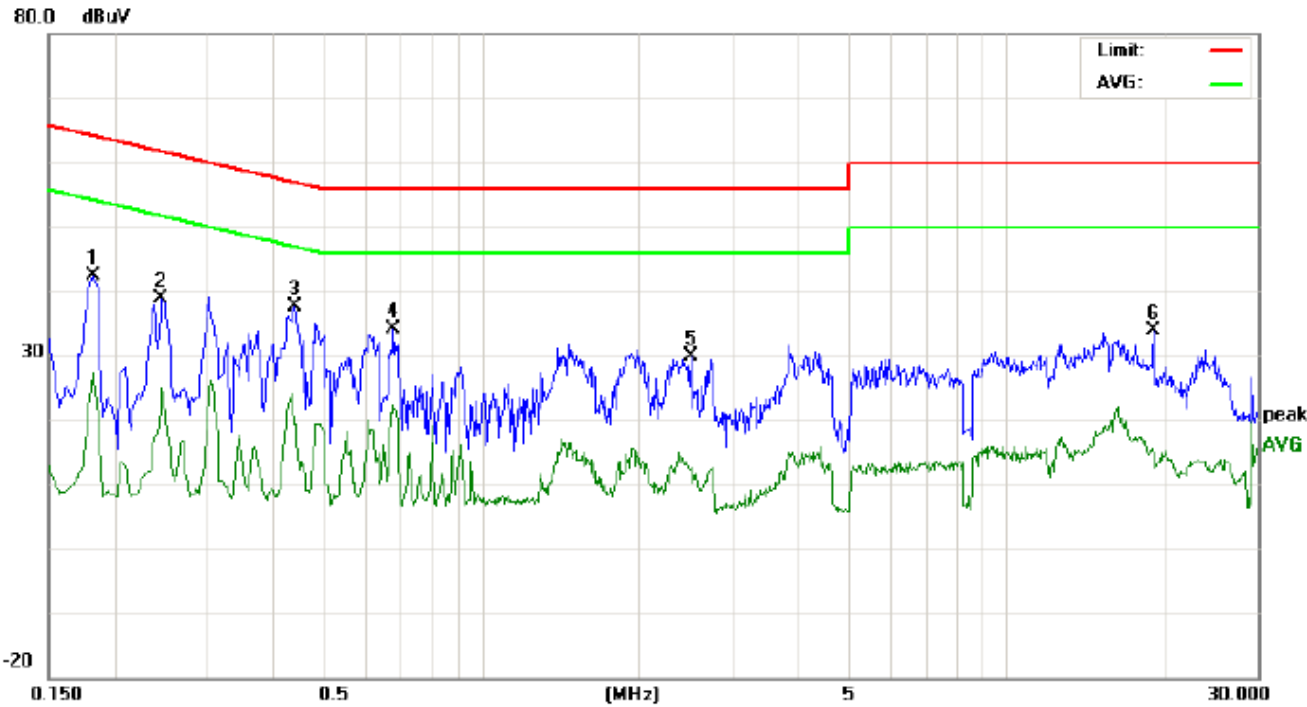

Site: Conduction Phase: **N** Temperature: 26  
 Limit: FCC Class B Conduction(QP) Power: Humidity: 60 %  
 EUT:Mini Keyboard  
 M/N:KB3  
 Mode:Data Transmission  
 Note:

No.	Freq. (MHz)	Reading_Level (dBuV)			Correct Factor (dB)	Measurement (dBuV)			Limit (dBuV)		Margin (dB)		P/F	Comment
		Peak	QP	AVG		Peak	QP	AVG	QP	AVG	QP	AVG		
1	0.1819	32.24		17.16	10.20	42.44	27.36	64.39	54.39	-21.95	-27.03	P		
2	0.2460	28.62		14.82	10.27	38.89	25.09	61.89	51.89	-23.00	-26.80	P		
3	0.4420	27.36		9.10	10.36	37.72	19.46	57.02	47.02	-19.30	-27.56	P		
4	0.6820	22.38		2.45	10.34	32.72	12.79	56.00	46.00	-23.28	-33.21	P		
5	2.5100	19.39		2.10	10.43	29.82	12.53	56.00	46.00	-26.18	-33.47	P		
6	19.0259	23.78		5.04	10.12	33.90	15.16	60.00	50.00	-26.10	-34.84	P		

RESULT: PASS

## 9. FCC RADIATED EMISSION TEST

### 9.1. LIMITS OF RADIATED EMISSION TEST

Frequency (MHz)	Distance (m)	Maximum Field Strength Limit (dBuV/m/ Q.P.)
30~88	3	40.0
88~216	3	43.5
216~960	3	46.0
960~1000	3	54.0

Note: The lower limit shall apply at the transition frequency.

#### 9.1.1 The following table is the setting of spectrum analyzer and receiver:

Spectrum Parameter	Setting
Start ~Stop Frequency	9KHz~150KHz/RB 200Hz for QP
Start ~Stop Frequency	150KHz~30MHz/RB 9KHz for QP
Start ~Stop Frequency	30MHz~1000MHz/RB 120KHz for QP
Start ~Stop Frequency	1GHz~13GHz RBW 1MHz/ VBW 3MHz for Peak, RBW 1MHz/VBW 10Hz for Average

Receiver Parameter	Setting
Start ~Stop Frequency	9KHz~150KHz/RB 200Hz for QP
Start ~Stop Frequency	150KHz~30MHz/RB 9KHz for QP
Start ~Stop Frequency	30MHz~1000MHz/RB 120KHz for QP

9.2. BLOCK DIAGRAM OF TEST SETUP

RADIATED EMISSION TEST SETUP 30MHz-1000MHz

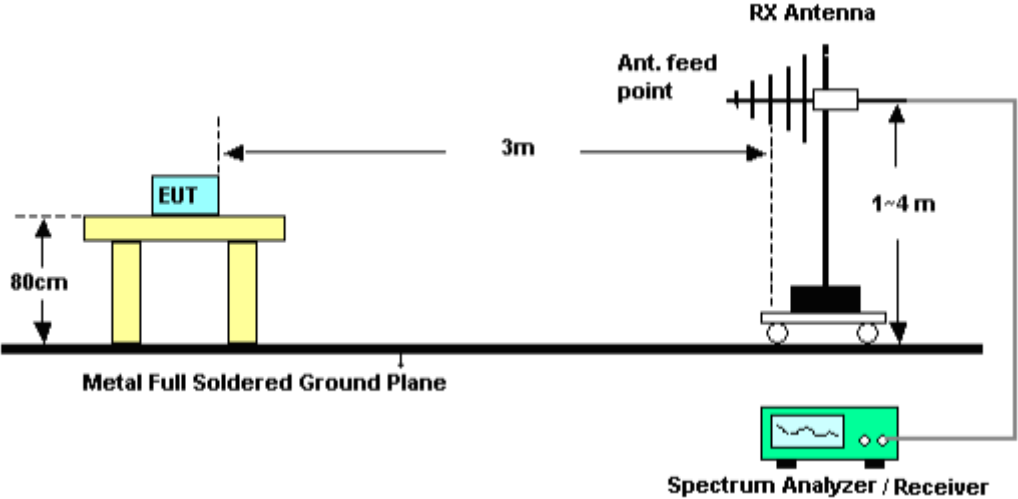

RADIATED EMISSION TEST SETUP ABOVE 1000MHz

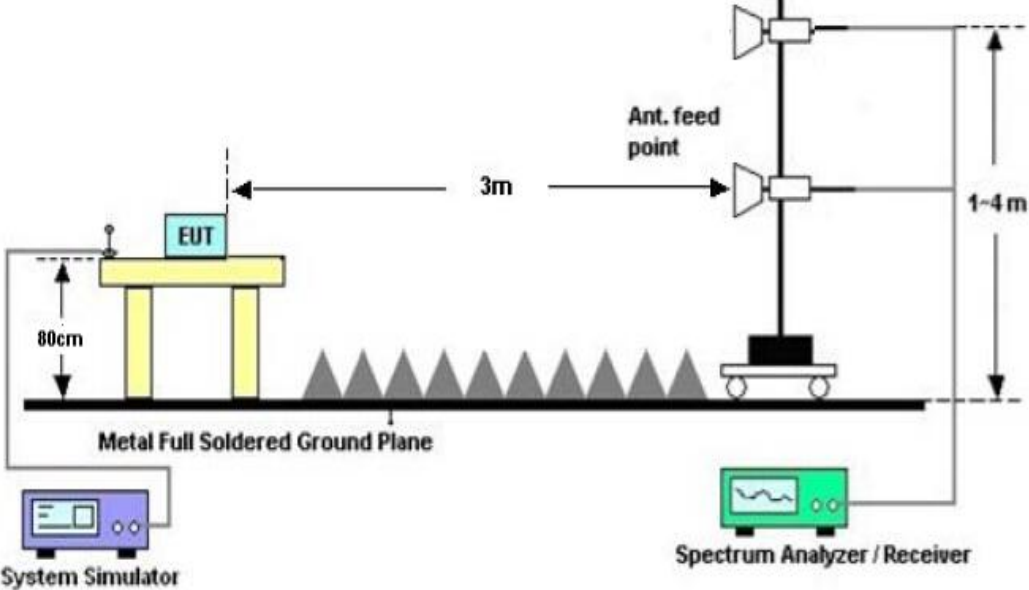

### 9.3. PROCEDURE OF RADIATED EMISSION TEST

1. Configure the EUT according to ANSI C63.4. The EUT was placed on the top of the turntable 0.8 meter above ground. The phase center of the receiving antenna mounted on the top of a height-variable antenna tower was placed 3 meters far away from the turntable.
2. Power on the EUT and all the supporting units. The turntable was rotated by 360 degrees to determine the position of the highest radiation.
3. The height of the broadband receiving antenna was varied between one meter and four meters above ground to find the maximum emissions field strength of both horizontal and vertical polarization.
4. For each suspected emissions, the antenna tower was scan (from 1 M to 4 M) and then the turntable was rotated (from 0 degree to 360 degrees) to find the maximum reading.
5. Set the test-receiver system to Peak or CISPR quasi-peak Detect Function with specified bandwidth under Maximum Hold Mode.
6. For emissions above 1GHz, use 1MHz RBW and 3MHz VBW for peak reading. Then 1MHz RBW and 10Hz VBW for average reading in spectrum analyzer.
7. When the radiated emissions limits are expressed in terms of the average value of the emissions, and pulsed operation is employed, the measurement field strength shall be determined by averaging over one complete pulse train, including blanking intervals, as long as the pulse train does not exceed 0.1 seconds. As an alternative (provided the transmitter operates for longer than 0.1 seconds) or in cases where the pulse train exceeds 0.1 seconds, the measured field strength shall be determined from the average absolute voltage during a 0.1 second interval during which the field strength is at its maximum values.

**9.4. TEST RESULT OF RADIATED EMISSION TEST**

Radiated Emission Test at 3m Distance(Below 1G)-Horizontal

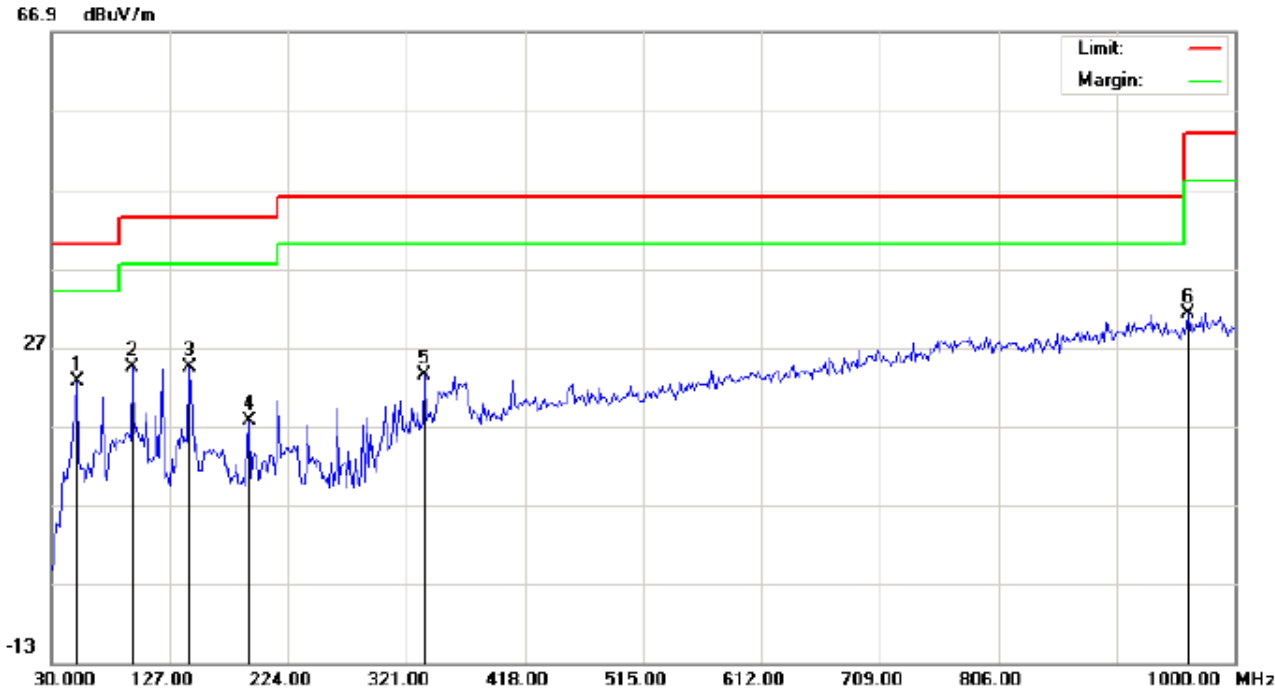

Site: site #1  
 Limit: FCC Class B 3M Radiation  
 EUT:Mini Keyboard  
 M/N: KB3  
 Mode: Data Transmission  
 Note:

Polarization: *Horizontal*  
 Power:  
 Distance:

Temperature: 22.4  
 Humidity: 52.5 %

No.	Mk	Freq.	Reading	Factor	Measurement	Limit	Over	Detector	Antenna Height	Table Degree	Comment
		MHz	dBuV	dB/m	dBuV/m	dBuV/m	dB		cm	degree	
1	*	51.0167	12.48	10.15	22.63	40.00	-17.37	peak			
2		96.2833	17.55	6.77	24.32	43.50	-19.18	peak			
3		143.1667	9.89	14.43	24.32	43.50	-19.18	peak			
4		191.6667	5.94	11.61	17.55	43.50	-25.95	peak			
5		335.5500	5.60	17.78	23.38	46.00	-22.62	peak			
6		961.2000	1.25	29.89	31.14	54.00	-22.86	peak			









**APPENDIX A: PHOTOGRAPHS OF TEST SETUP**  
FCC LINE CONDUCTED EMISSION TEST SETUP

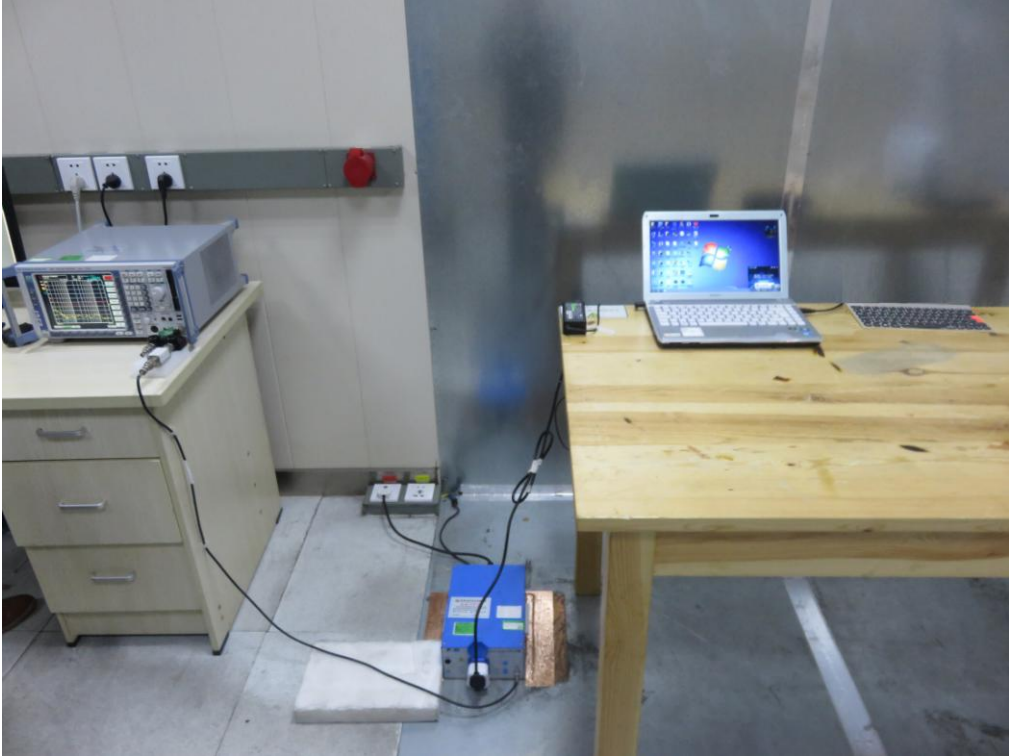

FCC RADIATED EMISSION TEST SETUP

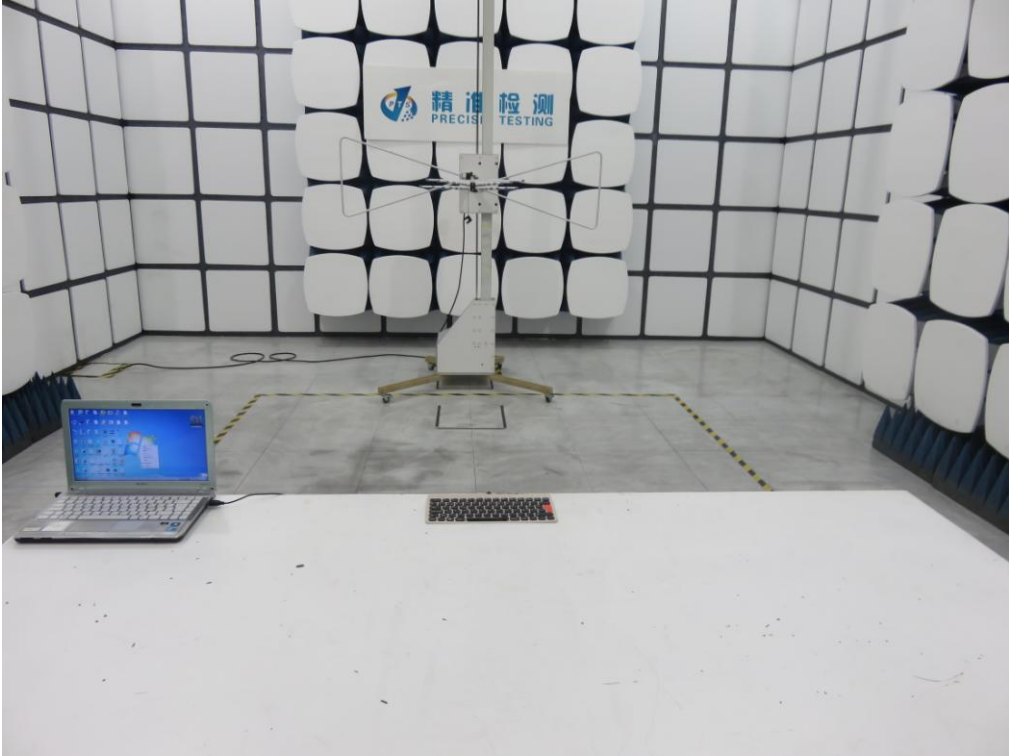

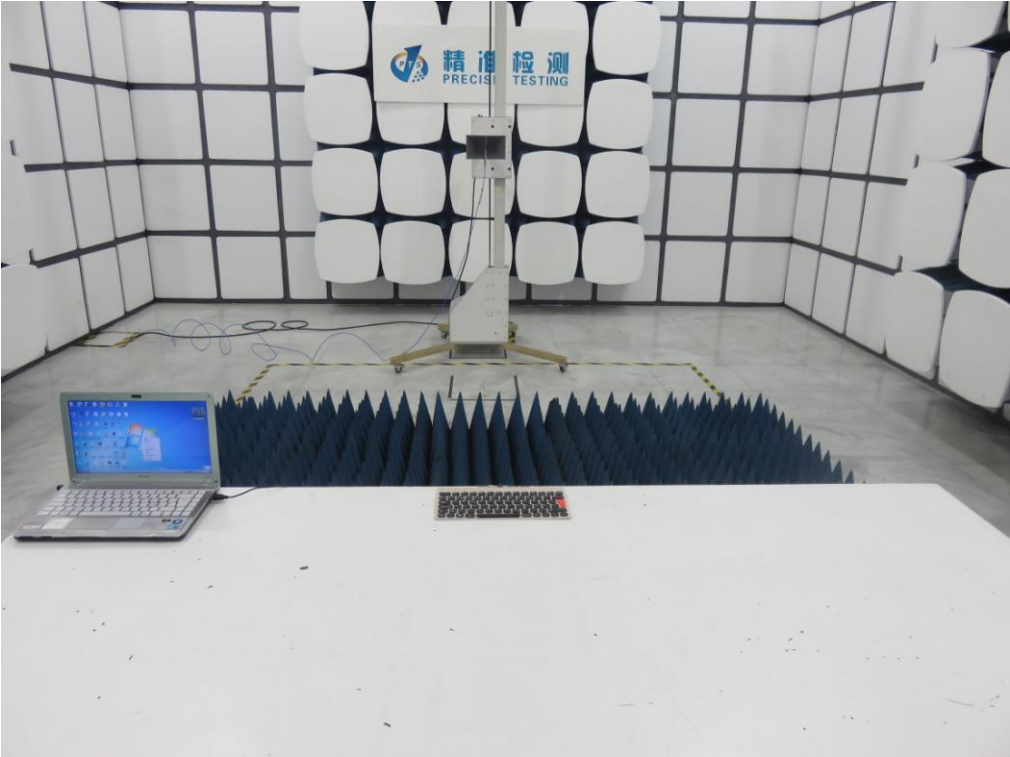

**APPENDIX B: PHOTOGRAPHS OF EUT**  
TOP VIEW OF EUT



BOTTOM VIEW OF EUT

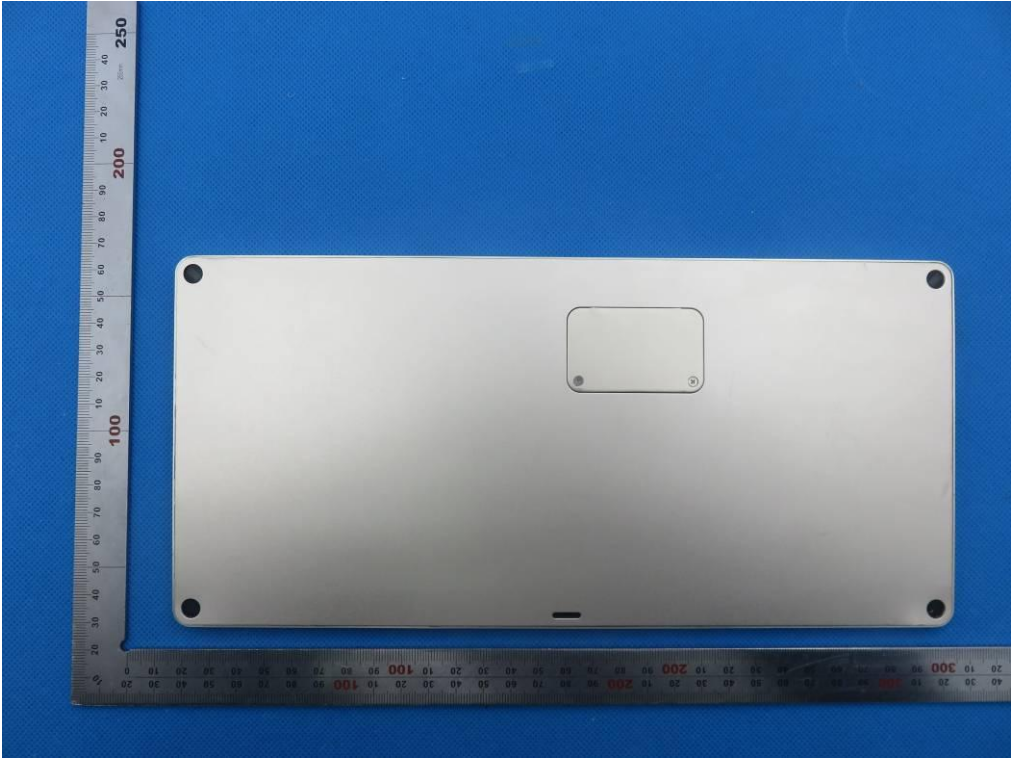

FRONT VIEW OF EUT



BACK VIEW OF EUT



LEFT VIEW OF EUT



RIGHT VIEW OF EUT





VIEW OF EUT (PORT)



OPEN VIEW OF EUT

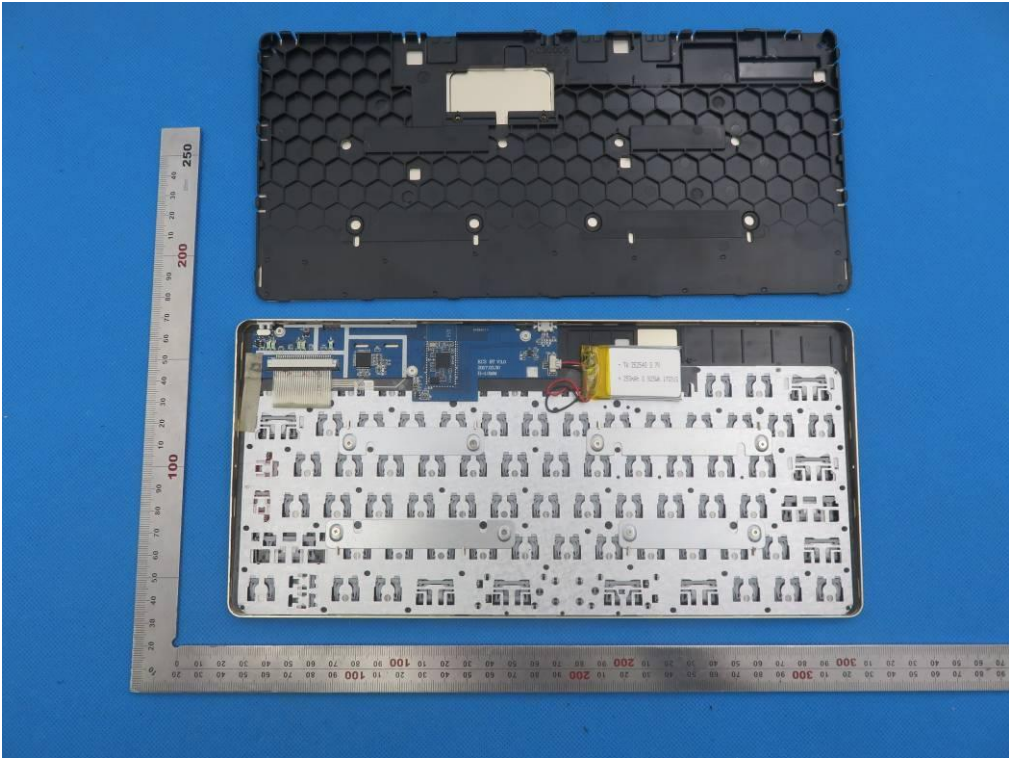

INTERNAL VIEW OF EUT-1

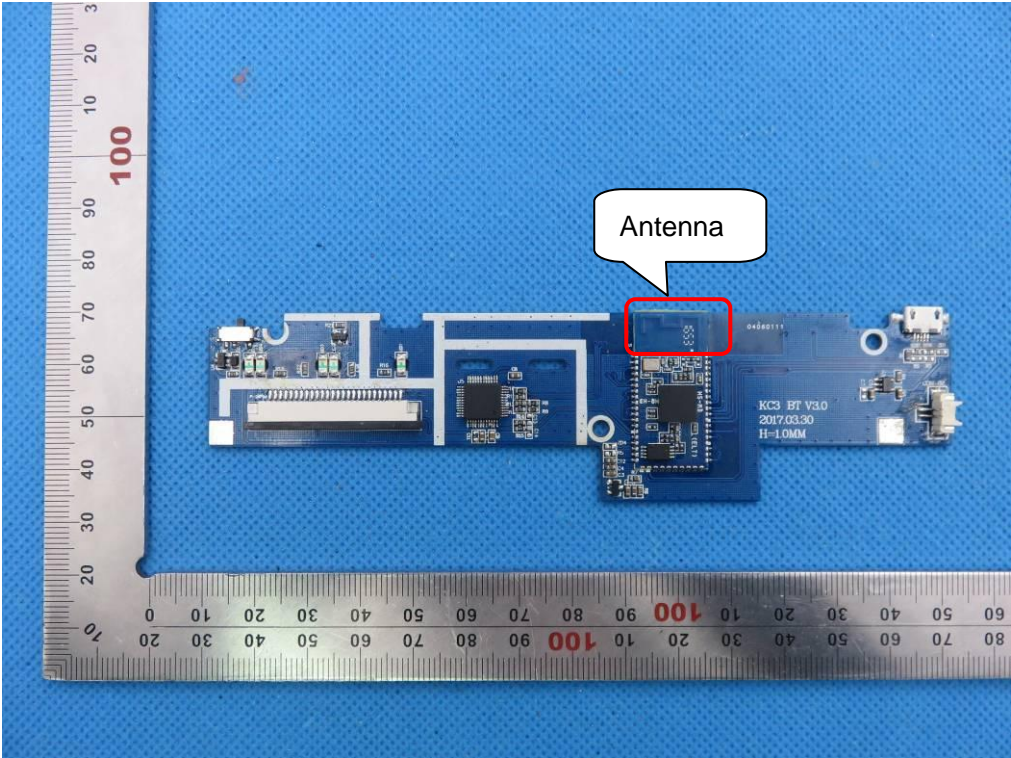

INTERNAL VIEW OF EUT-2

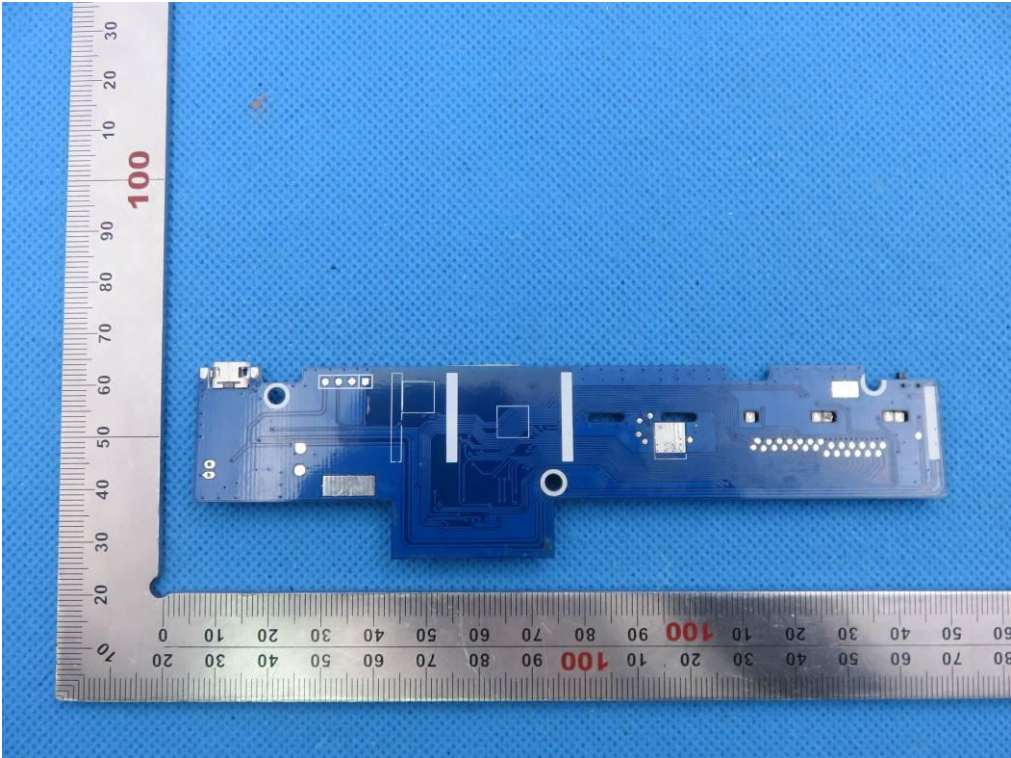

INTERNAL VIEW OF EUT-3

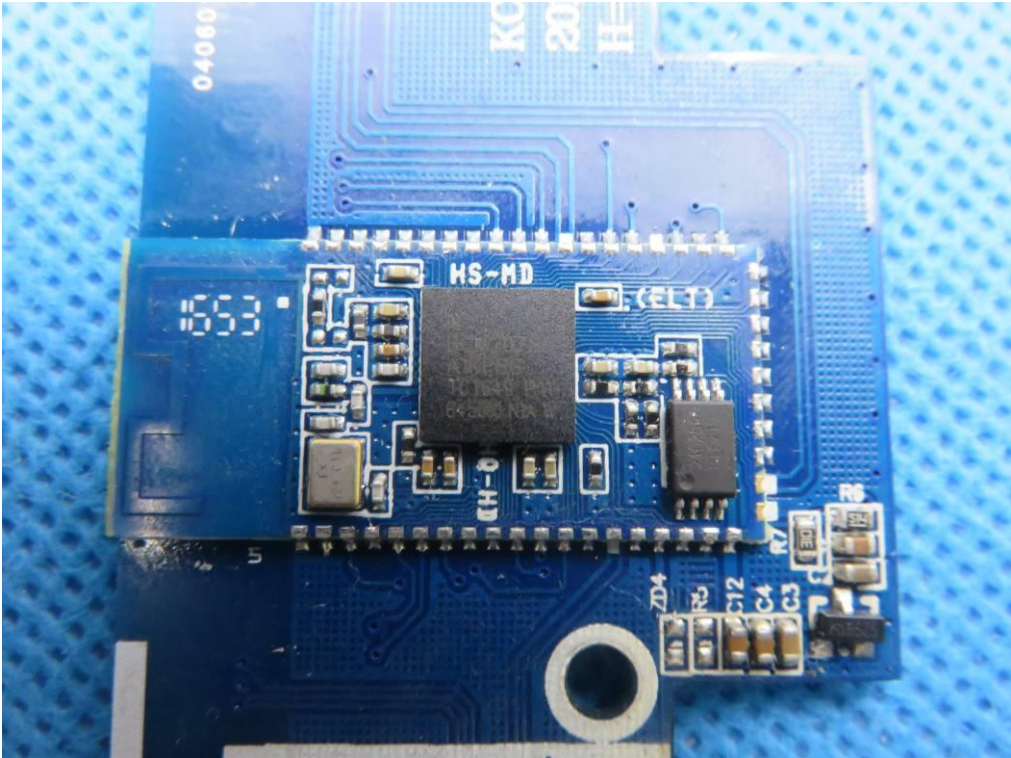

----END OF REPORT----