

# FCC TEST REPORT

Reference No..... : WTU15U0628982E

Applicant..... : Suzhou Switek Electronics&Technology Co, Ltd.

Address..... : No.86, South WuSong Road, Luzhi Town, Wuzhong District, Suzhou City.

Manufacturer ..... : The same as above

Address..... : The same as above

Product Name..... : Double slide LCD control platform

Model No..... : AS-7104ULD,AS-7108ULD,AS-7116ULD,AS-9104ULD, AS-9108ULD,AS-9116ULD

FCC ID..... : ZQXAS-9116ULD

Standards..... : FCC PART15\_2013

Date of Receipt sample .... : April 28, 2015

Date of Test ..... : July 10, 2015~July 20, 2015

Date of Issue..... : July 22, 2015

Test Report Form No..... : FCC 15-1A

Test Result..... : **Pass \***

Remarks:

The results shown in this test report refer only to the sample(s) tested, this test report cannot be reproduced, except in full, without prior written permission of the company.  
 The report would be invalid without specific stamp of test institute and the signatures of compiler and approver.

**Prepared By:**

**Waltek Services (Shenzhen) Co., Ltd.**

Address: 1/F., Fukangtai Building, West Baima Road, Songgang Street, Baoan District, Shenzhen, Guangdong, China

Testing location: 1/F., Fukangtai Building, West Baima Road, Songgang Street, Baoan District, Shenzhen, Guangdong, China

Compiled by:

Approved by:



Fish.Yu / Project Engineer

Philo Zhong / Manager

## 1 Test Summary

Test Item	Test Requirement	Class	Test Method	Test Result
Conducted Emission (150KHz to 30MHz)	FCC PART15.107_2013	Class B	ANSI C63.4: 2009	Pass
Radiated Emission (30MHz to 1GHz)	FCC PART15.109_2013	Class B	ANSI C63.4: 2009	Pass

Remark:

Pass

Fail

N/A

Test item meets the requirement

Test item does not meet the requirement

Test case does not apply to the test object



## 2 Contents

	Page
<b>COVER PAGE</b> .....	<b>1</b>
<b>1 TEST SUMMARY</b> .....	<b>2</b>
<b>2 CONTENTS</b> .....	<b>3</b>
<b>3 GENERAL INFORMATION</b> .....	<b>4</b>
3.1 GENERAL DESCRIPTION OF E.U.T. ....	4
3.2 DETAILS OF E.U.T.....	4
3.3 DESCRIPTION OF SUPPORT UNITS.....	4
3.4 STANDARDS APPLICABLE FOR TESTING .....	4
3.5 TEST FACILITY.....	5
3.6 SUBCONTRACTED.....	5
3.7 ABNORMALITIES FROM STANDARD CONDITIONS .....	5
<b>4 EQUIPMENT USED DURING TEST</b> .....	<b>6</b>
4.1 MEASUREMENT UNCERTAINTY.....	6
<b>5 EMISSION TEST RESULTS</b> .....	<b>7</b>
5.1 MAINS TERMINALS DISTURBANCE VOLTAGE, 150KHZ TO 30MHZ.....	7
5.1.1 E.U.T. Operation.....	7
5.1.2 Block Diagram of Test Setup.....	7
5.1.3 Measurement Data.....	8
5.1.4 Mains Terminals Disturbance Voltage Test Data.....	9
5.2 RADIATION EMISSION DATA FOR 9KHZ TO 1000MHZ.....	11
5.2.1 E.U.T. Operation.....	11
5.2.2 Block Diagram of Test Setup.....	11
5.2.3 Test Procedure.....	12
5.2.4 Measurement Data.....	13
<b>6 PHOTOGRAPHS – TEST SETUP</b> .....	<b>16</b>
6.1 PHOTOGRAPH –DISTURBANCE VOLTAGE TEST SETUP .....	16
6.2 PHOTOGRAPH –RADIATED EMISSION TEST SETUP.....	17
<b>7 PHOTOGRAPHS – CONSTRUCTIONAL DETAILS</b> .....	<b>18</b>
7.1 EUT -FRONT VIEW.....	18
7.2 EUT –BACK VIEW.....	19
7.3 EUT –OPEN VIEW.....	20
7.4 EUT –PCB -FRONT VIEW .....	21
7.5 EUT –PCB –BACK VIEW.....	24

### 3 General Information

#### 3.1 General Description of E.U.T.

<b>Product Name</b> .....	: Double slide LCD control platform
<b>Model No.</b> .....	: AS-7104ULD,AS-7108ULD,AS-7116ULD,AS-9104ULD, AS-9108ULD,AS-9116ULD
<b>FCC ID</b> .....	: ZQXAS-9116ULD
<b>Remark</b> .....	: The PCB of all models are identical except for the number of VGA ports and the panel size

#### 3.2 Details of E.U.T.

<b>Technical Data</b> .....	: Adapter input: 100V-240VAC, 50/60Hz, 1.5A Adapter Output: 12VDC, 4000mA
<b>The Highest Operation Frequency</b> ....	: 24MHz

#### 3.3 Description of Support Units

The EUT has been tested as an independent unit. AS-9116ULD is the test sample.

#### 3.4 Standards Applicable for Testing

The tests were performed according to following standards:

FCC PART 15\_2013      Electronic Code of Federal Regulations- Unintentional Radiators

# WALTEK

### 3.5 Test Facility

The test facility has a test site registered with the following organizations:

- **FCC Test Site 1#– Registration No.: 880581**

Waltek Services(Shenzhen) Co., Ltd. EMC Laboratory `has been registered and fully described in a report filed with the (FCC) Federal Communications Commission. The acceptance letter from the FCC is maintained in our files. Registration 880581, April 29, 2014.

- **FCC Test Site 2#– Registration No.: 328995**

Waltek Services(Shenzhen) Co., Ltd. EMC Laboratory `has been registered and fully described in a report filed with the (FCC) Federal Communications Commission. The acceptance letter from the FCC is maintained in our files. Registration 328995, December 3, 2014.

### 3.6 Subcontracted

Whether parts of tests for the product have been subcontracted to other labs:

Yes       No

If Yes, list the related test items and lab information:

Test Lab:      N/A

Lab address:    N/A

Test items:     N/A

### 3.7 Abnormalities from Standard Conditions

None.



# WALTEK

**4 Equipment Used during Test**

<input checked="" type="checkbox"/> Conducted Emission						
Item	Equipment	Manufacturer	Model No.	Serial No.	Last Calibration Date	Calibration Due Date
1.	EMI Test Receiver	ROHDE&SCHWARZ	ESCI	101297	2015-07-19	2016-07-18
2.	Two-Line V-Network	ROHDE&SCHWARZ	ENV216	101538	2014-07-30	2015-07-29
3.	Manual RF SW	ESE	RSU-A41	-	-	-
4.	3m,50 ohms Cable	HUBER SUHNER	1016873	-	-	-
<input checked="" type="checkbox"/> 3m Semi-anechoic Chamber for Radiation						
Item	Equipment	Manufacturer	Model No.	Serial No.	Last Calibration Date	Calibration Due Date
1.	EMI Test Receiver	ROHDE&SCHWARZ	ESCI	101346	2015-07-19	2016-07-18
2.	Trilog Broadband Antenna	SCHWARZBECK	VULB9163	580	2014-09-08	2015-09-07
3.	Broad-band Horn Antenna	SCHWARZBECK	BBHA 9120 D	1092	2014-09-08	2015-09-07
4.	Broadband Preamplifier	SCHWARZBECK	BBV 9743	0069	2014-07-30	2015-07-29
5.	Active Loop Antenna	Beijing Dazhi	ZN30900A	-	2014-08-12	2015-08-11
6.	8m 50 Ohm Coaxial Cable with N-plug	HUBER SUHNER	1016873	-	-	-
7.	3m 50 Ohm Coaxial Cable with N-plug	HUBER SUHNER	1016873	-	-	-

**4.1 Measurement Uncertainty**

Test Item	Frequency Range	Uncertainty	Note
Conduction disturbance	150kHz~30MHz	±3.64dB	(1)
Radiation	30MHz~1000MHz	±5.03dB	(1)

(1) This uncertainty represents an expanded uncertainty expressed at approximately the 95% confidence level using a coverage factor of  $k=2$ .



## 5 Emission Test Results

### 5.1 Mains Terminals Disturbance Voltage, 150kHz to 30MHz

Test Requirement.....	: FCC PART15.107_2013
Test Method.....	: ANSI C63.4_2009
Test Result.....	: Pass
Test Limit.....	: FCC PART 15, SUBPART B Section 15.107
Frequency Range.....	: 150kHz to 30MHz
Class.....	: Class B

#### 5.1.1 E.U.T. Operation

##### Operating Environment:

Temperature.....	: 23°C
Humidity.....	: 45%RH
Atmospheric Pressure.....	: 101Kbar

##### EUT Operation:

Input Voltage.....	: AC120V/60Hz
Operating Mode.....	: Max power mode

#### 5.1.2 Block Diagram of Test Setup

The Mains Terminals Disturbance Voltage tests were performed in accordance with the FCC PART 15, SUBPART B .

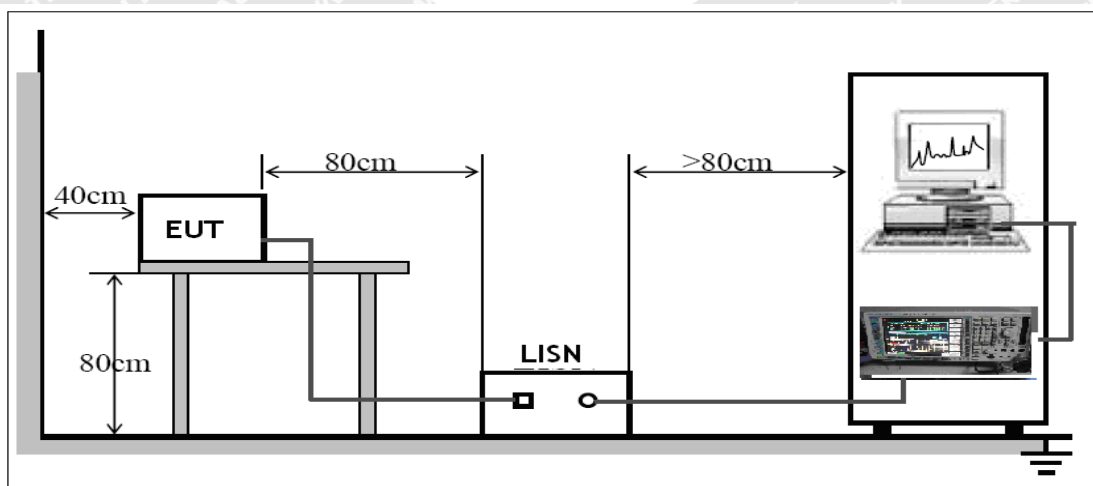

### 5.1.3 Measurement Data

The maximised peak emissions from the EUT was scanned and measured for both the Live and Neutral Lines. Quasi-peak & average measurements were performed if peak emissions were within 6dB of the average limit line. According to the data in section 5.1.4, the EUT complied with the FCC PART 15, SUBPART B standards.

Remark: Test Limit

Frequency of emission (MHz)	Conducted limit (dB $\mu$ V)	
	Quasi-peak	Average
0.15–0.5	66 to 56*	56 to 46*
0.5–5	56	46
5–30	60	50



# WALTEK



### 5.1.4 Mains Terminals Disturbance Voltage Test Data Live Line:

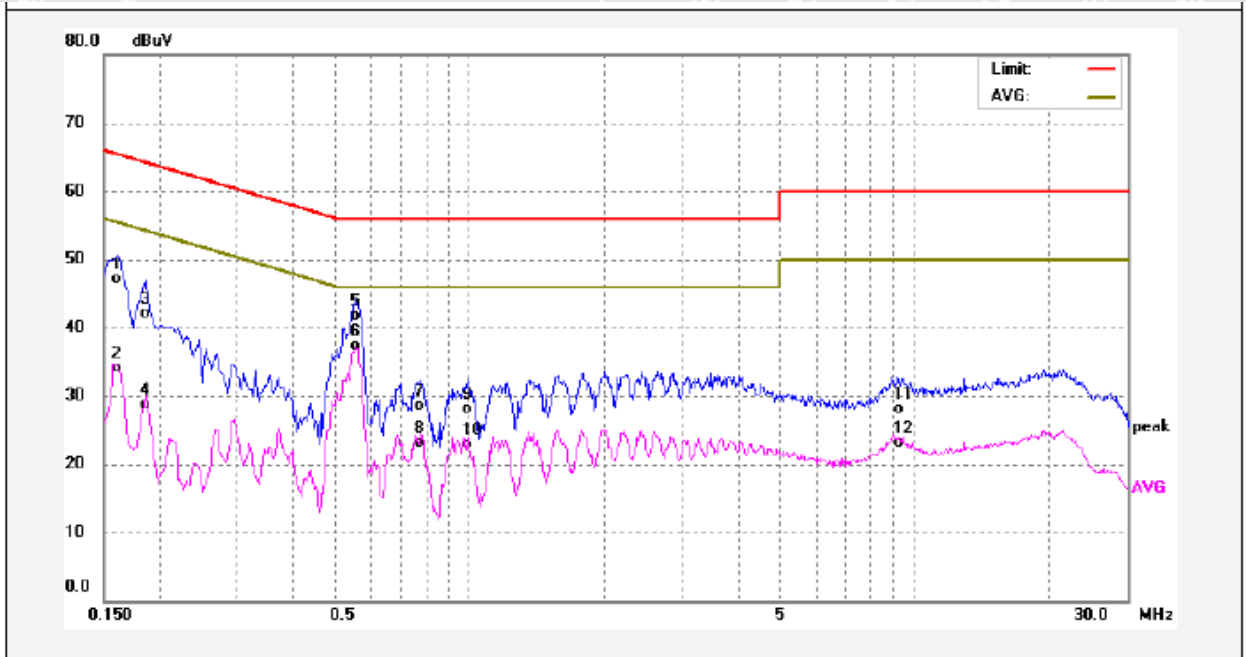

No.	Freq. (MHz)	Reading (dBuV)	Factor (dB)	Result (dBuV)	Limit dBuV	Margin (dB)	Detector	Remark
1	0.1620	37.54	9.61	47.15	65.36	-18.21	QP	
2	0.1620	24.43	9.61	34.04	55.36	-21.32	AVG	
3	0.1864	32.43	9.60	42.03	64.19	-22.16	QP	
4	0.1864	19.01	9.60	28.61	54.19	-25.58	AVG	
5	0.5540	32.21	9.57	41.78	56.00	-14.22	QP	
6	0.5540	27.72	9.57	37.29	46.00	-8.71	AVG	
7	0.7700	18.88	9.57	28.45	56.00	-27.55	QP	
8	0.7700	13.58	9.57	23.15	46.00	-22.85	AVG	
9	0.9860	18.55	9.58	28.13	56.00	-27.87	QP	
10	0.9860	13.25	9.58	22.83	46.00	-23.17	AVG	
11	9.1180	18.34	9.76	28.10	60.00	-31.90	QP	
12	9.1180	13.38	9.76	23.14	50.00	-26.86	AVG	

**Neutral Line:**

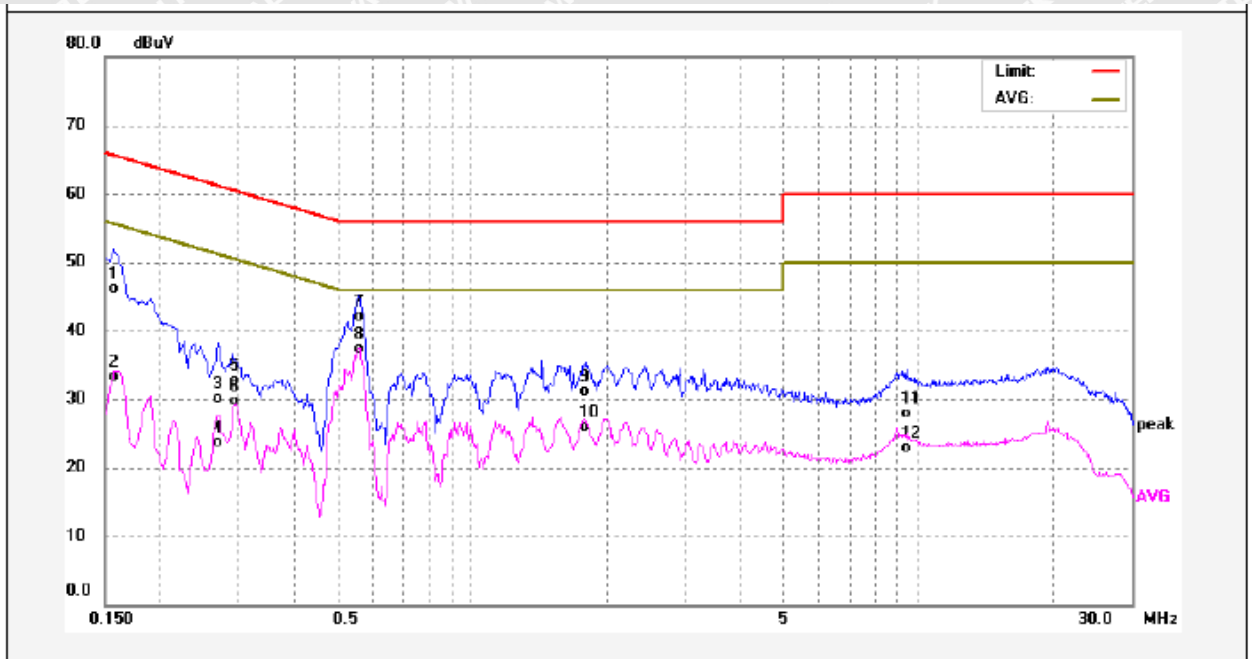

No.	Freq. (MHz)	Reading (dBuV)	Factor (dB)	Result (dBuV)	Limit (dBuV)	Margin (dB)	Detector	Remark
1	0.1580	36.43	9.61	46.04	65.56	-19.52	QP	
2	0.1580	23.60	9.61	33.21	55.56	-22.35	AVG	
3	0.2700	20.49	9.60	30.09	61.12	-31.03	QP	
4	0.2700	14.02	9.60	23.62	51.12	-27.50	AVG	
5	0.2900	23.04	9.59	32.63	60.52	-27.89	QP	
6	0.2900	20.07	9.59	29.66	50.52	-20.86	AVG	
7	0.5580	32.45	9.57	42.02	56.00	-13.98	QP	
8	0.5580	27.75	9.57	37.32	46.00	-8.68	AVG	
9	1.8060	21.52	9.60	31.12	56.00	-24.88	QP	
10	1.8060	16.32	9.60	25.92	46.00	-20.08	AVG	
11	9.3979	18.24	9.76	28.00	60.00	-32.00	QP	
12	9.3979	13.11	9.76	22.87	50.00	-27.13	AVG	

### 5.2 Radiation Emission Data For 9kHz to 1000MHz

<b>Test Requirement</b> .....	:	FCC PART15.109_2013
<b>Test Method</b> .....	:	ANSI C63.4_2009
<b>Test Limit</b> .....	:	FCC PART 15, SUBPART B Section 15.109
<b>Test Result</b> .....	:	Pass
<b>Frequency Range</b> .....	:	9kHz to 1000MHz
<b>Class</b> .....	:	Class B
<b>Measurement Distance</b> .....	:	3m

#### 5.2.1 E.U.T. Operation

**Operating Environment:**

<b>Temperature</b> .....	:	23°C
<b>Humidity</b> .....	:	45%RH
<b>Atmospheric Pressure</b> .....	:	101Kbar

**EUT Operation:**

<b>Input Voltage</b> .....	:	AC120V/60Hz
<b>Operating Mode</b> .....	:	Max power mode

#### 5.2.2 Block Diagram of Test Setup

The radiated emission tests were performed in the 3m Semi- Anechoic Chamber test site, using the setup accordance with the FCC PART 15, SUBPART B.

Below 30MHz

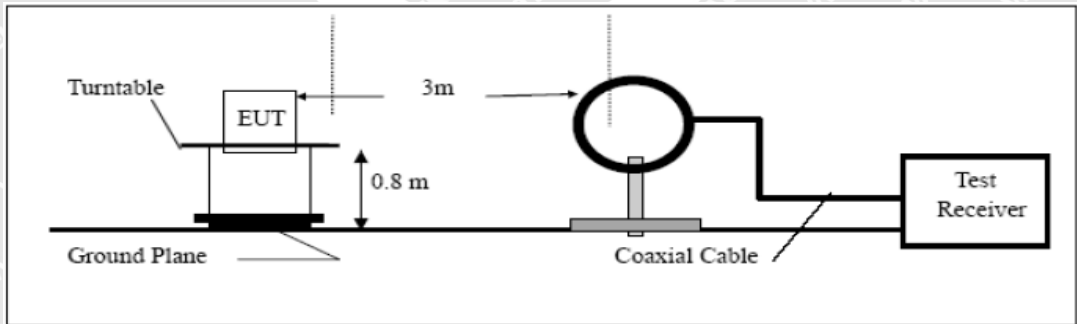

30MHz ~ 1000MHz

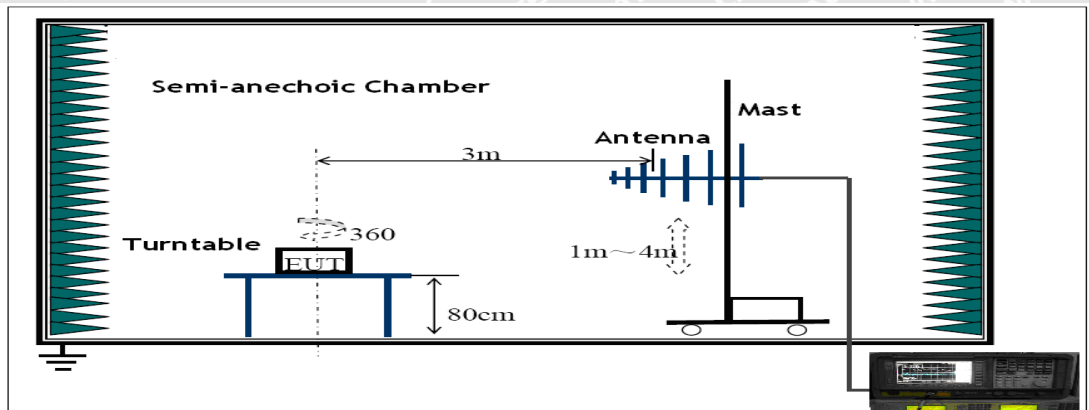

### 5.2.3 Test Procedure

1. **a) Test Procedure (below 30MHz)**

- (1) The EUT is placed on a turntable, which is 0.8m above ground plane.
- (2) The turntable shall be rotated for 360 degrees to determine the position of maximum emission level.
- (3) EUT is set 3m away from the receiving antenna.
- (4) Maximum procedure was performed on the six highest emissions to ensure EUT compliance.
- (5) Repeat above procedures until the measurements for all frequencies are complete.
- (6) AC source used during test.

**b) Test Procedure (above 30MHz)**

- (1) The EUT is placed on a turntable, which is 0.8m above ground plane.
- (2) The turntable shall be rotated for 360 degrees to determine the position of maximum emission level.
- (3) EUT is set 3m away from the receiving antenna, which is moved from 1m to 4m to find out the maximum emissions.
- (4) Maximum procedure was performed on the six highest emissions to ensure EUT compliance.
- (5) And also, each emission was to be maximized by changing the polarization of receiving antenna both horizontal and vertical.
- (6) Repeat above procedures until the measurements for all frequencies are complete.
- (7) The radiation measurements are performed in X,Y,Z axes position, the worst is X position.
- (8) AC source used during test.

2. Operating Mode: Full Load Mode (EUT power supplied DC 9-12V from the adaptor, The EUT one side connect PC1 with network port, the other side connect PC2 with DB15 cable. during the test, PC1 is out of the test chamber, PC2 and EUT are in the test chamber, PC1 remote control PC2 by the soft of KVMviewer.exe that was been loading from the EUT)

3. Test software: Audix EZ-EMC

4. Peak sweep refresh time: 100us

5. QP reading time: 1s



## 5.2.4 Measurement Data

According to the data in section 5.2.4, the EUT complied with the FCC PART 15, SUBPART B standards.

Remark :

(1)The test Frequency range judgment basis:

Highest frequency generated or used in the device or on which the device operates or tunes (MHz)	Upper frequency of measurement range (MHz)
Below 1.705	30.
1.705–108	1000.
108–500	2000.
500–1000	5000.
Above 1000	5th harmonic of the highest frequency or 40 GHz, whichever is lower.

(2) The test Limit :

Frequency of emission (MHz)	Field strength (microvolts/meter)
0.009 ~ 0.490	$10000 * 2400/F(\text{kHz})$
0.490 ~ 1.705	$100 * 24000/F(\text{kHz})$
1.705 ~ 30	$100 * 30$
30–88	100
88–216	150
216–960	200
Above 960	500



**(1)Radiated Emission test datas,30MHz to 1000MHz:**

Antenna Horizontal

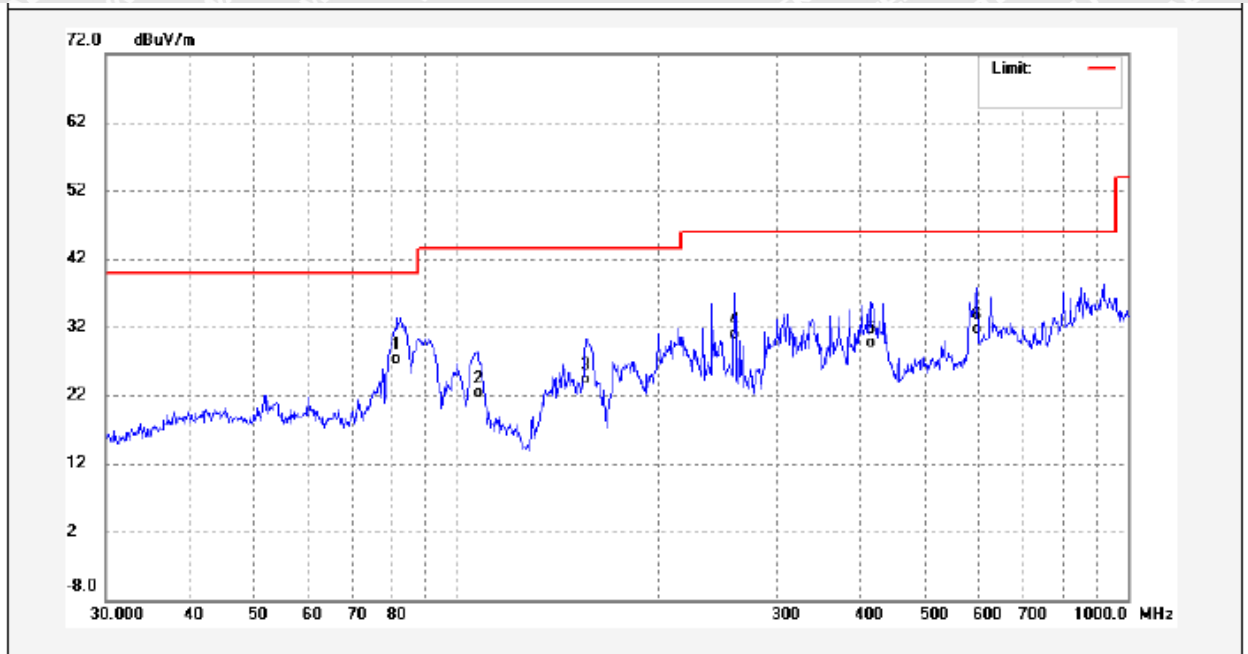

No.	Freq. (MHz)	Reading (dBuV/m)	Factor (dB)	Result (dBuV/m)	Limit (dBuV/m)	Margin (dB)	Detector	Remark
1	81.4970	15.85	11.49	27.34	40.00	-12.66	QP	
2	107.5101	9.73	12.57	22.30	43.50	-21.20	QP	
3	155.9101	14.06	10.15	24.21	43.50	-19.29	QP	
4	259.2338	17.17	13.64	30.81	46.00	-15.19	QP	
5	414.7223	9.84	19.93	29.77	46.00	-16.23	QP	
6	595.1329	8.46	23.23	31.69	46.00	-14.31	QP	



Antenna Vertical

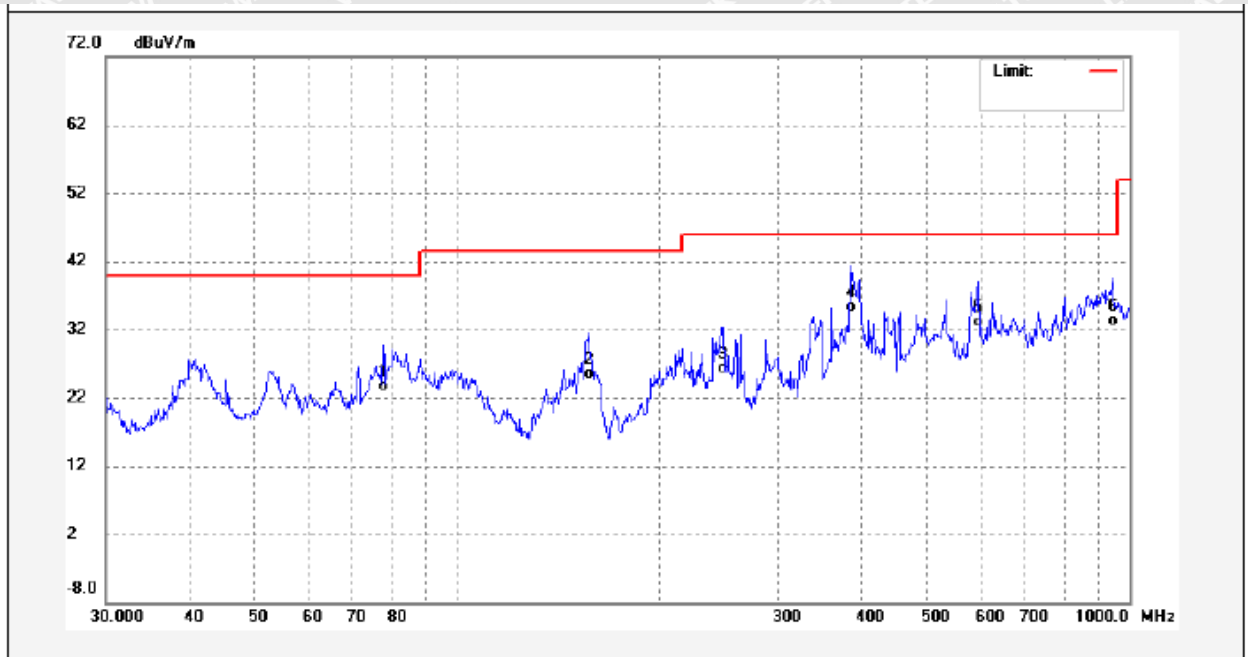

No.	Freq. (MHz)	Reading (dBuV/m)	Factor (dB)	Result (dBuV/m)	Limit (dBuV/m)	Margin (dB)	Detector	Remark
1	77.5928	12.59	11.14	23.73	40.00	-16.27	QP	
2	157.0074	15.13	10.32	25.45	43.50	-18.05	QP	
3	248.5519	11.87	14.51	26.38	46.00	-19.62	QP	
4	386.6338	15.84	19.39	35.23	46.00	-10.77	QP	
5	595.1329	9.87	23.23	33.10	46.00	-12.90	QP	
6	945.4399	4.68	28.72	33.40	46.00	-12.60	QP	



## 6 Photographs – Test Setup

### 6.1 Photograph –Disturbance Voltage Test Setup





## 6.2 Photograph –Radiated Emission Test Setup

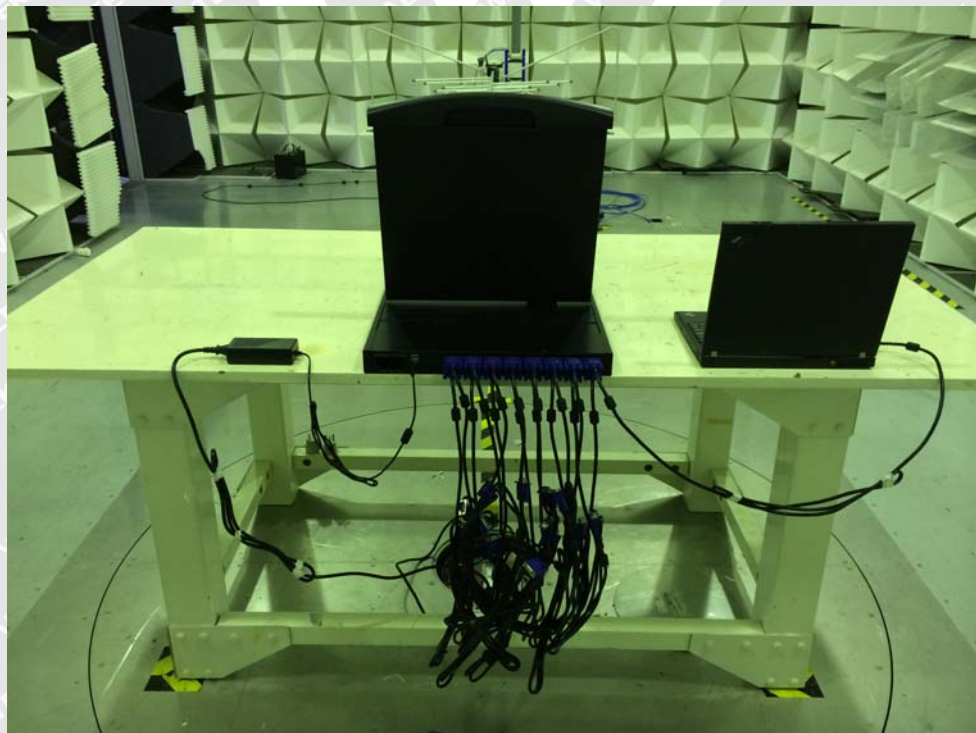

## 7 Photographs – Constructional Details

### 7.1 EUT -Front View





## 7.2 EUT –Back View





### 7.3 EUT –Open View

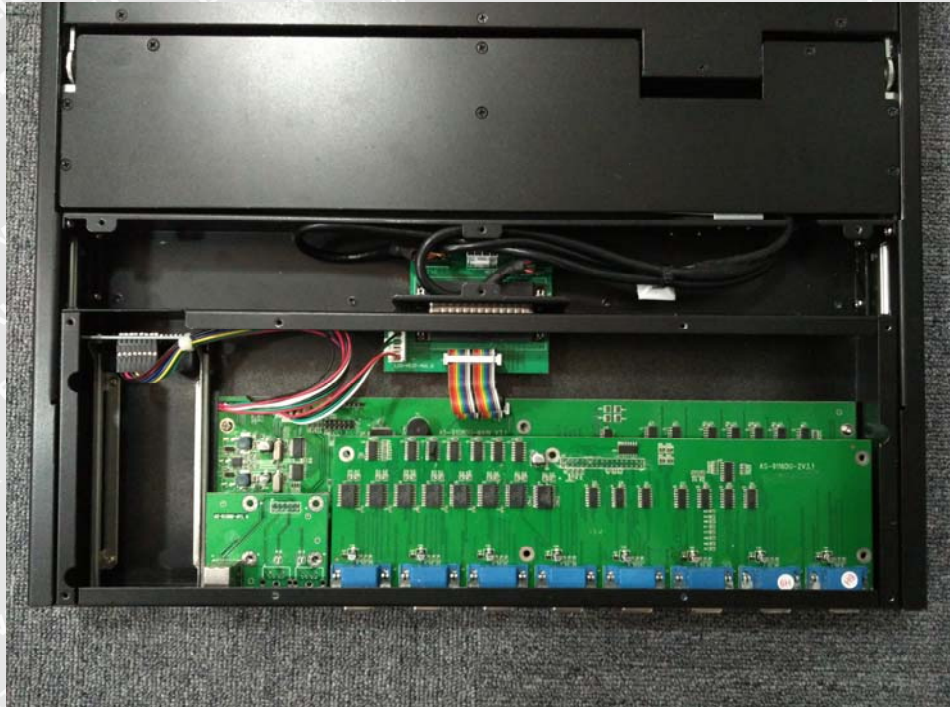



### 7.4 EUT -PCB -Front View

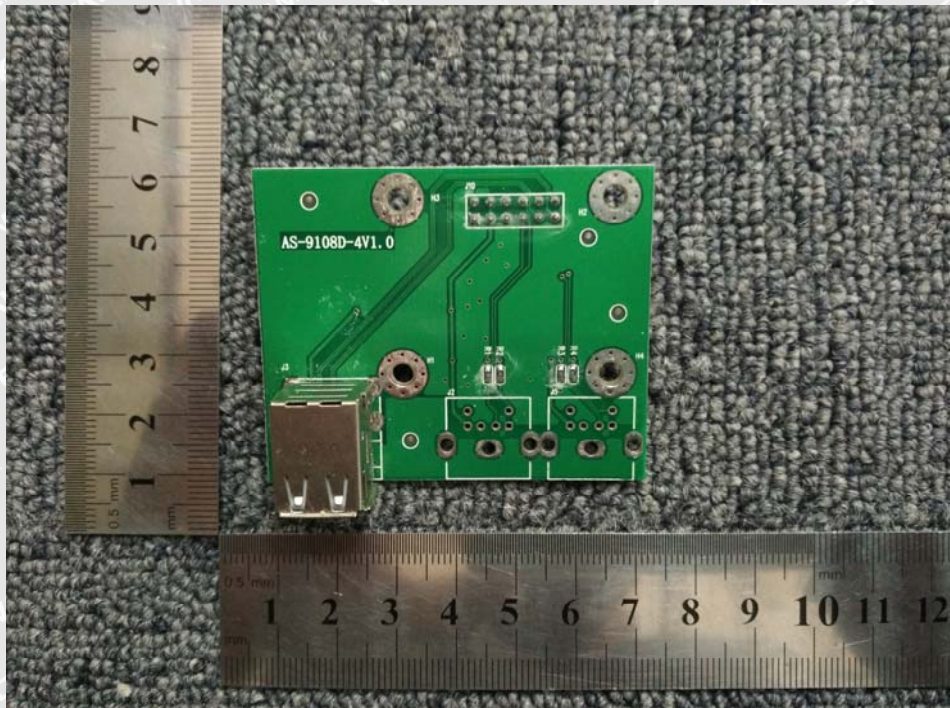



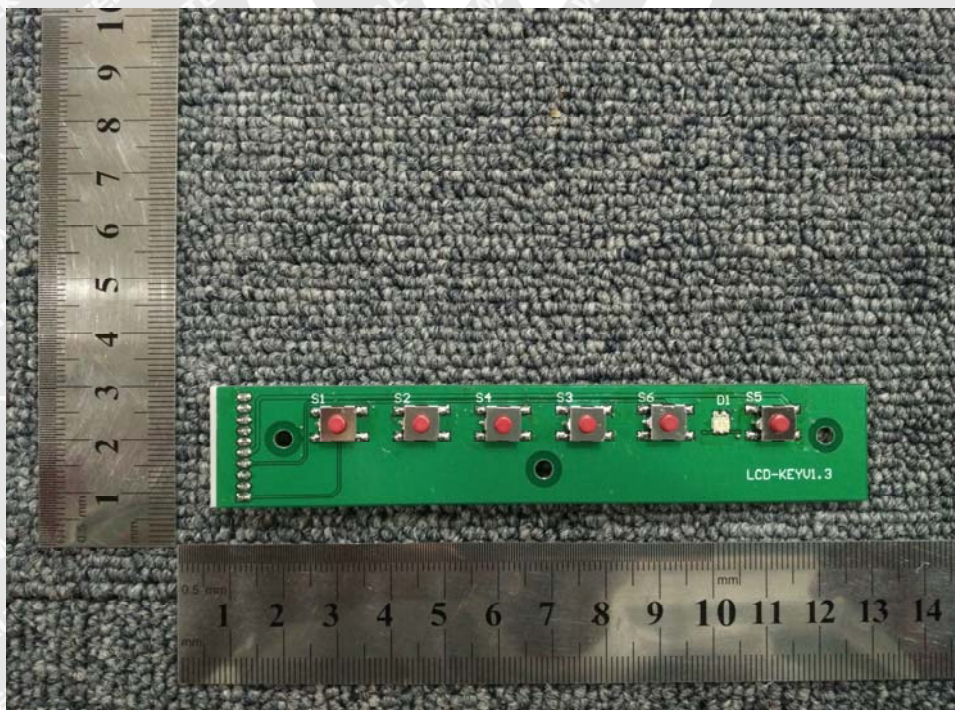



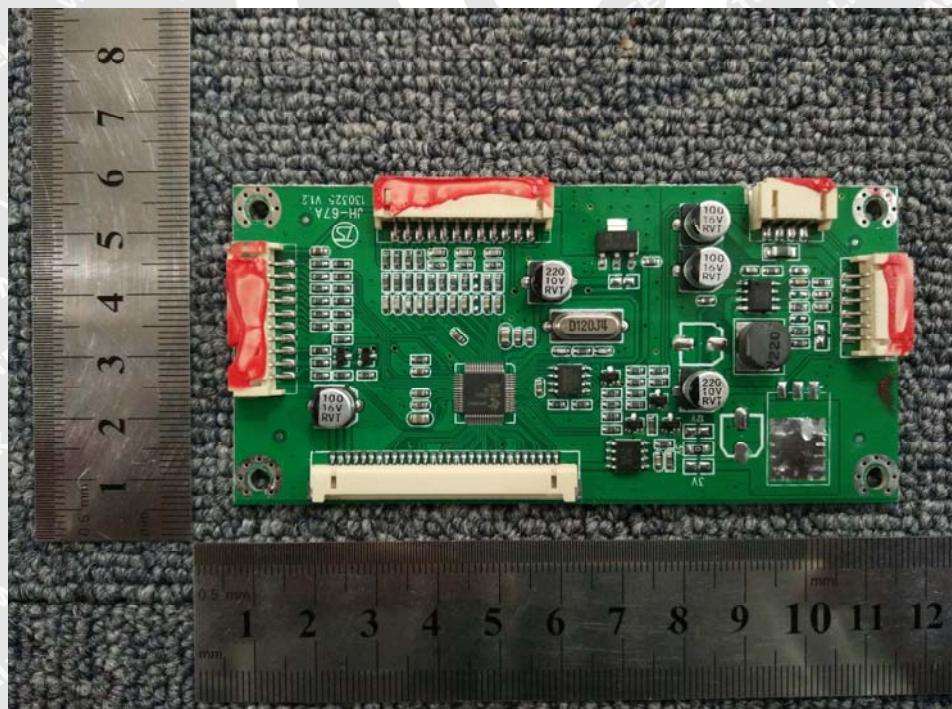
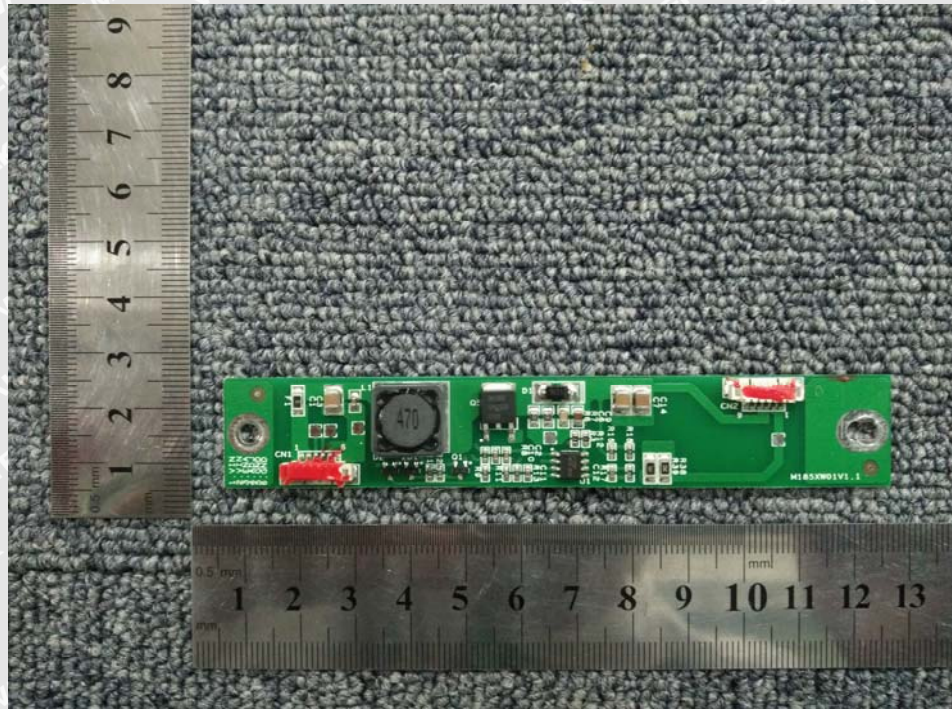

### 7.5 EUT –PCB –Back View



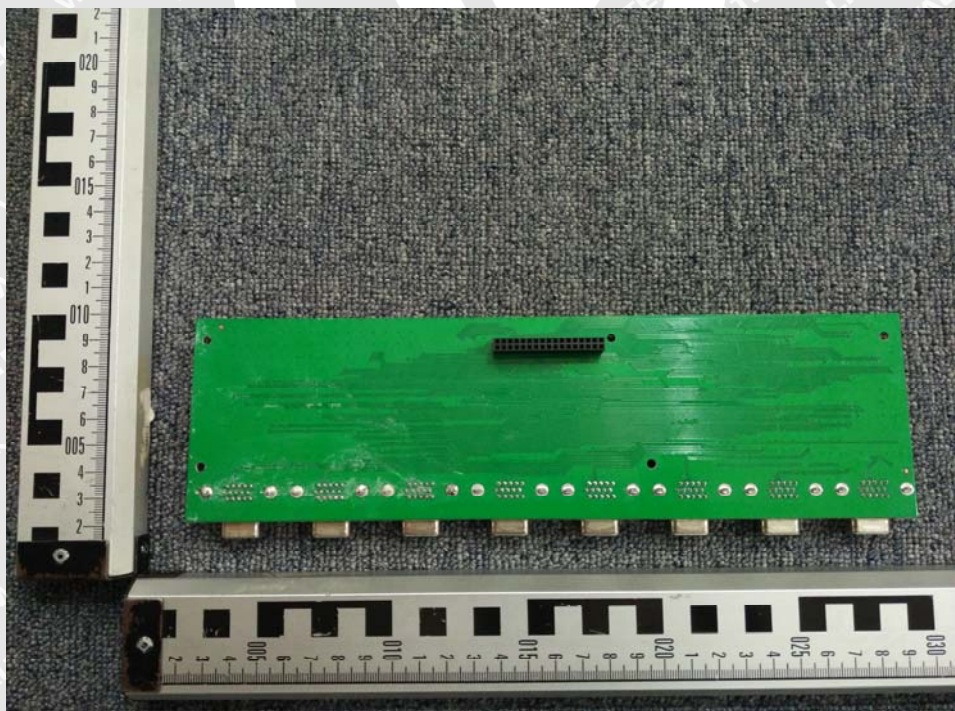
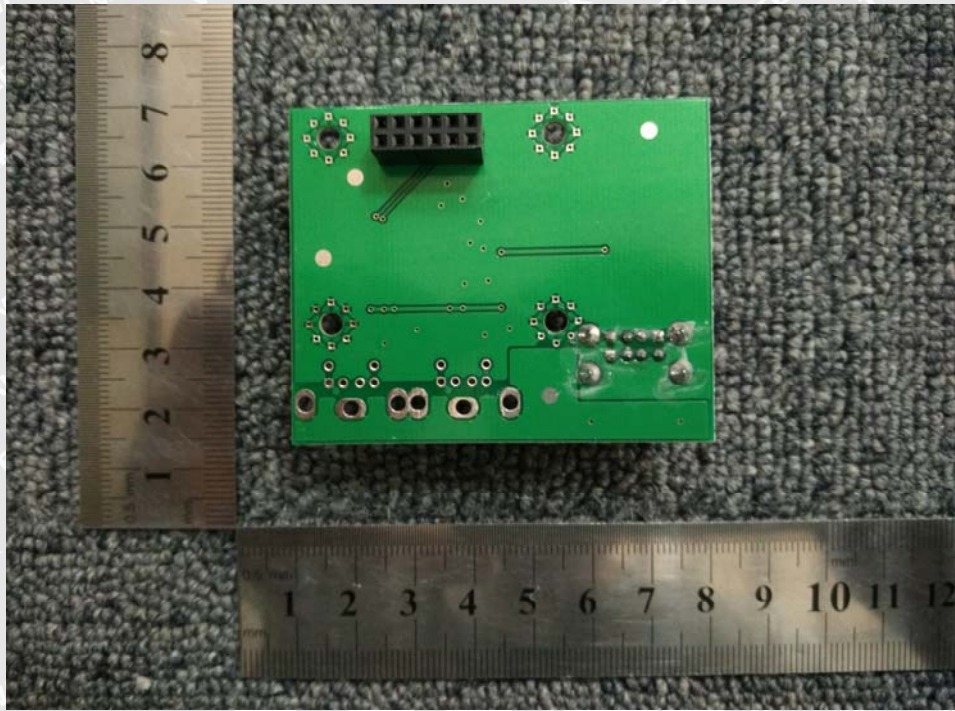



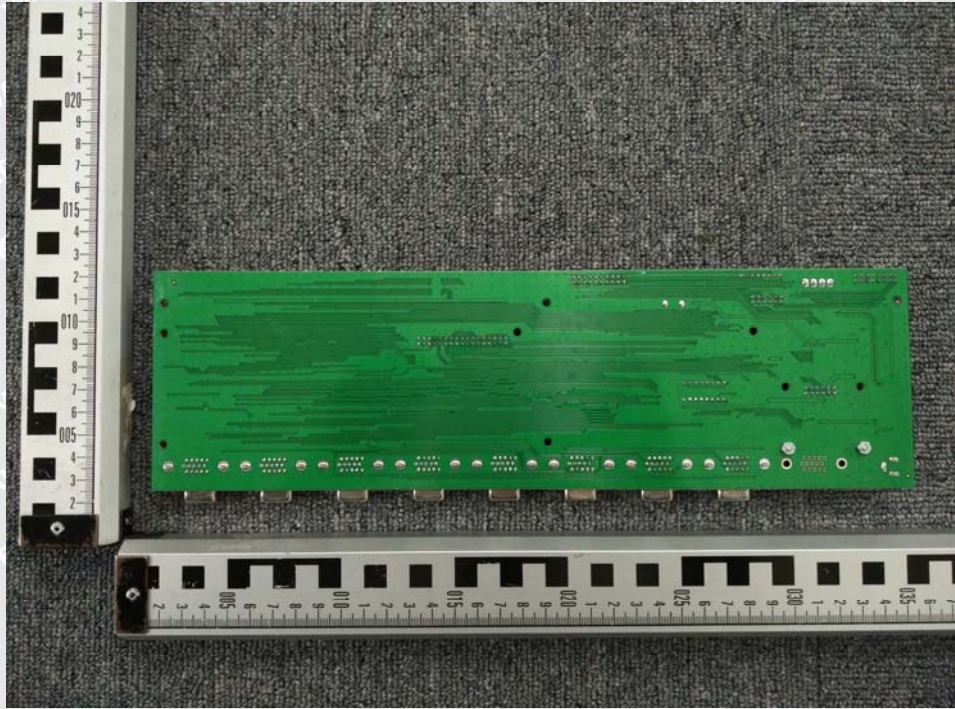



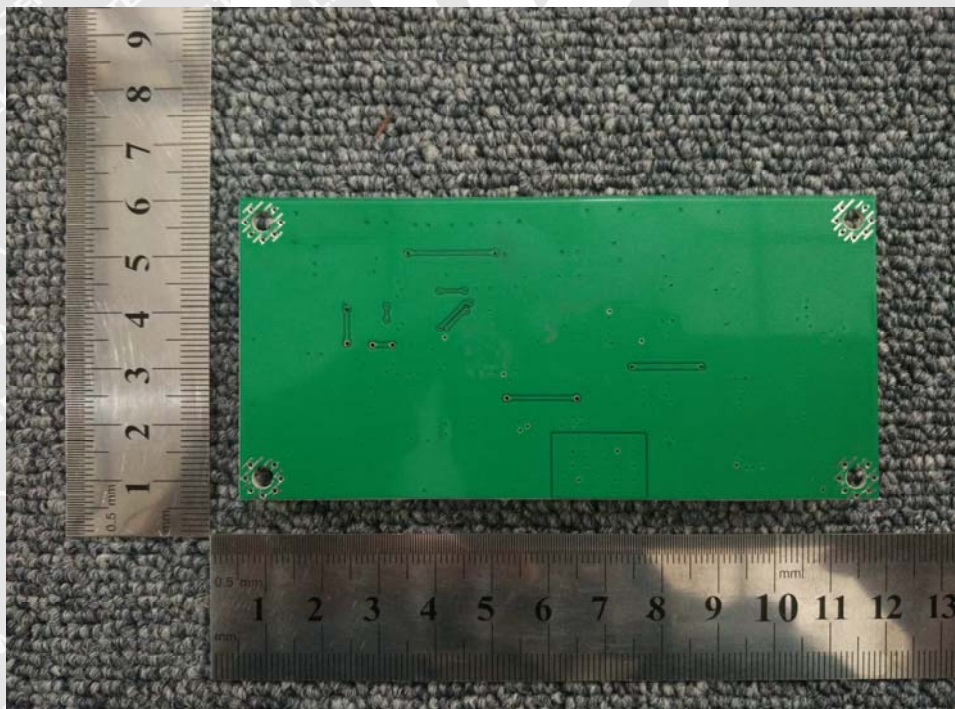

=====**End of Test Report**=====