



RADIO TEST REPORT

Test Report No. : 32EE0060-HO-C-R1

Applicant : SINFONIA TECHNOLOGY CO., LTD.
Type of Equipment : Digital Photo Printer
Model No. : CHC-S6145-5
Test regulation : FCC Part 15 Subpart C: 2012
FCC ID : ZQUCHC-S6145-5
Test Result : Complied

1. This test report shall not be reproduced in full or partial, without the written approval of UL Japan, Inc.
2. The results in this report apply only to the sample tested.
3. This sample tested is in compliance with above regulation.
4. The test results in this report are traceable to the national or international standards.
5. This test report must not be used by the customer to claim product certification, approval, or endorsement by NVLAP, NIST, or any agency of the Federal Government.
6. This report is a revised version of 32EE0060-HO-C. 32EE0060-HO-C is replaced with this report.

Date of test: January 23 to February 15, 2012

Representative test engineer: H. Kukita
Hiroshi Kukita
Engineer of WiSE Japan,
UL Verification Service

Approved by: M. Fujimura
Mitsuru Fujimura
Leader of WiSE Japan,
UL Verification Service

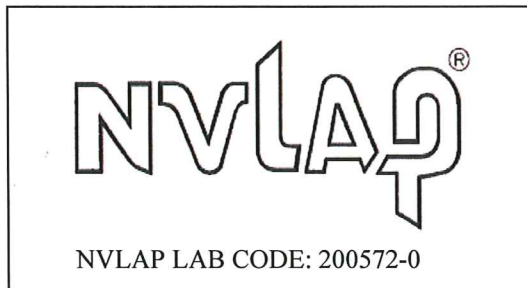

This laboratory is accredited by the NVLAP LAB CODE 200572-0, U.S.A. The tests reported herein have been performed in accordance with its terms of accreditation. *As for the range of Accreditation in NVLAP, you may refer to the WEB address, <http://www.ul.com/japan/jpn/pages/services/emc/about/mark1/index.jsp#nvlap>

CONTENTS	PAGE
SECTION 1: Customer information	3
SECTION 2: Equipment under test (E.U.T.)	3
SECTION 3: Test specification, procedures & results	4
SECTION 4: Operation of E.U.T. during testing	7
SECTION 5: Conducted emission	9
SECTION 6: Radiated emission (Fundamental, Spurious Emission and Spectrum Mask)	10
SECTION 7: Other test	11
APPENDIX 1: Data of EMI test	12
Conducted emission	12
Fundamental emission and Spectrum Mask	13
Spurious emission	14
20dB Bandwidth	17
99% Occupied Bandwidth	18
Frequency Tolerance	19
APPENDIX 2: Test instruments	20
APPENDIX 3: Photographs of test setup	21
Conducted emission	21
Radiated emission	22

SECTION 1: Customer information

Company Name : SINFONIA TECHNOLOGY CO.,LTD.
Address : 100 Takegahana-cho, Ise-shi, Mie-ken, 516-8550 JAPAN
Telephone Number : +81 596 36 1286
Facsimile Number : +81 596 36 3884
Contact Person : Tsutomu Inagaki

SECTION 2: Equipment under test (E.U.T.)

2.1 Identification of E.U.T.

Type of Equipment : Digital Photo Printer
Model No. : CHC-S6145-5
Serial No. : Refer to Section 4, Clause 4.2
Rating : AC 100-240V
Receipt Date of Sample : January 11, 2012
Country of Mass-production : Malaysia, Japan
Condition of EUT : Production prototype
(Not for Sale: This sample is equivalent to mass-produced items.)
Modification of EUT : No Modification by the test lab

2.2 Product description

Model: CHC-S6145-5 (referred to as the EUT in this report) is a Digital Photo Printer.
The EUT receives image data from PC, and the image is printed.

General Specification

The clock frequencies used in the EUT:

External: 24MHz, CPU: Internal 375MHz, SDRM: 133MHz, FPGA: 60MHz, RF-ID: 13.56MHz
USB: Communicate with PC at maximum 480Mbps

Radio Specification

Radio Type : Transceiver
Frequency of Operation : 13.56MHz
Modulation : ASK
Power Supply (radio part input) : DC 3.3V
Antenna type : Pattern Antenna

UL Japan, Inc.

Head Office EMC Lab.

4383-326 Asama-cho, Ise-shi, Mie-ken 516-0021 JAPAN

Telephone : +81 596 24 8116

Facsimile : +81 596 24 8124

SECTION 3: Test specification, procedures & results

3.1 Test Specification

Test Specification : FCC Part 15 Subpart C: 2012, final revised on February 1, 2012
Title : FCC 47CFR Part15 Radio Frequency Device Subpart C Intentional Radiators
Section 15.207 : Conducted limits
Section 15.225 : Operation within the band 13.110-14.010MHz

*The revision on February 1, 2012 does not affect the test specification applied to the EUT.

3.2 Procedures and results

Item	Test Procedure	Specification	Worst margin	Results	Remarks
Conducted emission	ANSI C63.4:2003 7. AC powerline conducted emission measurements <IC>RSS-Gen 7.2.2	Section 15.207 <IC>RSS-Gen 7.2.2	[QP]6.6dB 18.30214MHz, N [AV]7.6dB 18.30214MHz, N	N/A	-
Electric Field Strength of Fundamental Emission	ANSI C63.4:2003 13. Measurement of intentional radiators <IC> RSS-Gen 4.8, 4.11	Section 15.225(a) <IC>RSS-210 A2.6	91.3dB, 13.56000MHz, QP, 0deg.	Complied	Radiated
Spectrum Mask	ANSI C63.4:2003 13. Measurement of intentional radiators <IC>RSS-Gen 4.9, 4.11	Section 15.225(b)(c) <IC> RSS-210 A2.6	46.4dB, 13.02897MHz, QP, 0deg.	Complied	Radiated
20dB Bandwidth	ANSI C63.4:2003 13. Measurement of intentional radiators <IC> -	Section15.215(c) <IC> -	See data	Complied	Radiated
Electric Field Strength of Spurious Emission	ANSI C63.4:2003 13. Measurement of intentional radiators <IC>RSS-Gen 4.9, 4.11	Section15.209, Section 15.225 (d) <IC>RSS-210 A2.6	13.6dB (455.993MHz, Vertical, QP) (455.991MHz, Horizontal, QP) 3.8dB *1) (34.938MHz, Vertical, QP)	Complied	Radiated
Frequency Tolerance	ANSI C63.4:2003 13. Measurement of intentional radiators <IC>RSS-Gen 4.7	Section15.225(e) <IC> RSS-210 A2.6	See data	Complied	Radiated

Note: UL Japan, Inc.'s EMI Work Procedures No. 13-EM-W0420 and 13-EM-W0422

*1) This worst margin was noise from digital part, not from radio part.

FCC 15.31 (e)

This EUT provides stable voltage (DC 3.3V) constantly to RF Part regardless of input voltage. Therefore, this EUT complies with the requirement.

FCC Part 15.203 Antenna requirement

It is impossible for end users to replace the antenna, because the antenna is mounted inside of the EUT. Therefore, the equipment complies with the antenna requirement of Section 15.203.

UL Japan, Inc.

Head Office EMC Lab.

4383-326 Asama-cho, Ise-shi, Mie-ken 516-0021 JAPAN

Telephone : +81 596 24 8116

Facsimile : +81 596 24 8124

3.3 Addition to standard

No.	Item	Test Procedure	Specification	Remarks	Deviation	Worst margin	Results
1	99% Occupied Band Width	RSS-Gen 4.6.1	RSS-Gen 4.6.1	Radiated	N/A	N/A	N/A

Other than above, no addition, exclusion nor deviation has been made from the standard.

3.4 Uncertainty

EMI

The following uncertainties have been calculated to provide a confidence level of 95% using a coverage factor k=2.

Test room (semi-anechoic chamber)	Conducted emission (+dB)
	150kHz-30MHz
No.1	3.5dB
No.2	3.6dB
No.3	3.6dB
No.4	3.6dB

Test room (semi-anechoic chamber)	Radiated emission						
	(3m*)(+dB)				(1m*)(+dB)		(0.5m*)(+dB)
	9kHz -30MHz	30MHz -300MHz	300MHz -1GHz	1GHz -10GHz	10GHz -18GHz	18GHz -26.5GHz	26.5GHz -40GHz
No.1	4.2dB	5.0dB	5.1dB	4.7dB	5.7dB	4.4dB	4.3dB
No.2	4.1dB	5.2dB	5.1dB	4.8dB	5.6dB	4.3dB	4.2dB
No.3	4.5dB	5.0dB	5.2dB	4.8dB	5.6dB	4.5dB	4.2dB
No.4	4.7dB	5.2dB	5.2dB	4.8dB	5.6dB	5.1dB	4.2dB

*3m/1m/0.5m = Measurement distance

Frequency counter (+)	
Normal condition	Extreme condition
7×10^{-6}	9×10^{-6}

Conducted emission test

The data listed in this test report has enough margin, more than the site margin.

Radiated emission test (3m)

The data listed in this report meets the limits unless the uncertainty is taken into consideration.

UL Japan, Inc.

Head Office EMC Lab.

4383-326 Asama-cho, Ise-shi, Mie-ken 516-0021 JAPAN

Telephone : +81 596 24 8116

Facsimile : +81 596 24 8124

3.5 Test Location

UL Japan, Inc. Head Office EMC Lab. *NVLAP Lab. code: 200572-0
4383-326 Asama-cho, Ise-shi, Mie-ken 516-0021 JAPAN
Telephone : +81 596 24 8116 Facsimile : +81 596 24 8124

	FCC Registration Number	IC Registration Number	Width x Depth x Height (m)	Size of reference ground plane (m) / horizontal conducting plane	Other rooms
No.1 semi-anechoic chamber	313583	2973C-1	19.2 x 11.2 x 7.7m	7.0 x 6.0m	No.1 Power source room
No.2 semi-anechoic chamber	655103	2973C-2	7.5 x 5.8 x 5.2m	4.0 x 4.0m	-
No.3 semi-anechoic chamber	148738	2973C-3	12.0 x 8.5 x 5.9m	6.8 x 5.75m	No.3 Preparation room
No.3 shielded room	-	-	4.0 x 6.0 x 2.7m	N/A	-
No.4 semi-anechoic chamber	134570	2973C-4	12.0 x 8.5 x 5.9m	6.8 x 5.75m	No.4 Preparation room
No.4 shielded room	-	-	4.0 x 6.0 x 2.7m	N/A	-
No.5 semi-anechoic chamber	-	-	6.0 x 6.0 x 3.9m	6.0 x 6.0m	-
No.6 shielded room	-	-	4.0 x 4.5 x 2.7m	4.75 x 5.4 m	-
No.6 measurement room	-	-	4.75 x 5.4 x 3.0m	4.75 x 4.15 m	-
No.7 shielded room	-	-	4.7 x 7.5 x 2.7m	4.7 x 7.5m	-
No.8 measurement room	-	-	3.1 x 5.0 x 2.7m	N/A	-
No.9 measurement room	-	-	8.0 x 4.5 x 2.8m	2.0 x 2.0m	-
No.10 measurement room	-	-	2.6 x 2.8 x 2.5m	2.4 x 2.4m	-
No.11 measurement room	-	-	3.1 x 3.4 x 3.0m	2.4 x 3.4m	-

* Size of vertical conducting plane (for Conducted Emission test) : 2.0 x 2.0m for No.1, No.2, No.3, and No.4 semi-anechoic chambers and No.3 and No.4 shielded rooms.

3.6 Test set up, Data of EMI, and Test instruments

Refer to APPENDIX.

SECTION 4: Operation of E.U.T. during testing

4.1 Operating Modes

The mode is used :

Mode	Remarks
Transmitting (Tx and Rx) mode	With Tag
The EUT was operated in a manner similar to typical use during the tests. The EUT Transmits and Receives at the same time and there is no receiving mode.	
*Power Setting: same as production model Software: T0187600-0086-E0 Any conditions under the normal use do not exceed the condition of setting. In addition, end users cannot change the settings of the output power of the product.	

Justification: The system was configured in typical fashion (as a customer would normally use it) for testing.

Frequency Tolerance:

Temperature : -30deg.C to +50deg.C Step 10deg.C
Voltage : Normal Voltage AC 120V (Rating: AC 100 - 240V)
Maximum Voltage AC 276V(AC 240V +15%),
Minimum Voltage AC 85V (AC 100V -15%)

*This EUT provides stable voltage (DC 3.3V) constantly to RF Part regardless of input voltage.

UL Japan, Inc.

Head Office EMC Lab.

4383-326 Asama-cho, Ise-shi, Mie-ken 516-0021 JAPAN

Telephone : +81 596 24 8116

Facsimile : +81 596 24 8124

4.2 Configuration and peripherals

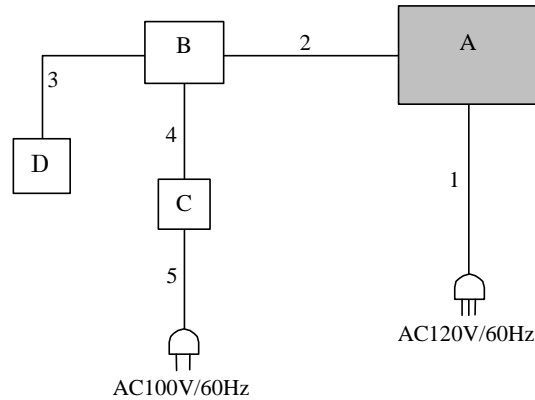

* Cabling and setup were taken into consideration and test data was taken under worse case conditions.

Description of EUT and Support equipment

No.	Item	Model number	Serial number	Manufacturer	Remarks
A	Digital Photo Printer	CHC-S6145-5	009	SINFONIA TECHNOLOGY CO.,LTD.	EUT
B	Laptop PC	T61	L3R2056	lenovo	-
C	AC Adapter	92P1160	11S92P1160Z1ZB GH7B99A8	lenovo	-
D	Mouse	M-UB48	LZE02601001	Logitech	-

List of cables used

No.	Name	Length (m)	Shield		Remark
			Cable	Connector	
1	AC Cable	1.4	Unshielded	Unshielded	-
2	USB Cable	2.0	Shielded	Shielded	-
3	USB Cable	0.75	Shielded	Shielded	-
4	DC Cable	1.8	Unshielded	Unshielded	-
5	AC Cable	0.9	Unshielded	Unshielded	-

UL Japan, Inc.

Head Office EMC Lab.

4383-326 Asama-cho, Ise-shi, Mie-ken 516-0021 JAPAN

Telephone : +81 596 24 8116

Facsimile : +81 596 24 8124

SECTION 5: Conducted emission

5.1 Operating environment

Test place : No.4 semi anechoic chamber
Temperature : See data
Humidity : See data

5.2 Test configuration

EUT was placed on a urethane platform of nominal size, 1.0m by 1.5m, raised 0.8m above the conducting ground plane. The rear of tabletop was located 40cm to the vertical conducting plane. The rear of EUT and its peripherals was aligned and flushed with rear of tabletop. All other surfaces of tabletop were at least 80cm from any other grounded conducting surface. EUT was located 80cm from LISN/AMN and excess AC cable was bundled in center. I/O cables that were connected to the peripherals were bundled in center. They were folded back and forth forming a bundle 30cm to 40cm long and were hanged at a 40cm height to the ground plane. Each EUT current-carrying power lead, except the ground (safety) lead, was individually connected through a LISN/ an AMN to the input power source. All unused 50ohm connectors of the LISN/ AMN were resistively terminated in 50ohm when not connected to the measuring equipment. The AC Mains Terminal Continuous disturbance Voltage has been measured with the EUT on a horizontal conducting plane 4.0 x 4.0m and a vertical conducting plane 2.0 x 2.0m in a semi Anechoic Chamber. Photographs of the set up are shown in Appendix 3.

5.3 Test conditions

Frequency range : 0.15MHz-30MHz
EUT position : Table top
EUT operation mode : See Clause 4.1

5.4 Test procedure

The AC Mains Terminal Continuous disturbance Voltage had been measured with the EUT in the semi Anechoic Chamber. The EUT was connected to a Line Impedance Stabilization Network (LISN)/ Artificial Mains Network (AMN). An overview sweep with peak detection has been performed. The measurements had been performed with a quasi-peak detector and if required, with an average detector. The conducted emission measurements were made with the following detector function of the test receiver.

Detector Type : QP and AV
IF Bandwidth : 9kHz

5.5 Test result

Summary of the test results : Pass

SECTION 6: Radiated emission (Fundamental, Spurious Emission and Spectrum Mask)

Test Procedure

EUT was placed on a urethane platform of nominal size, 1.0m by 1.5m, raised 0.8m above the conducting ground plane. The Radiated Electric Field Strength has been measured in a Semi Anechoic Chamber with a ground plane. The height of the measuring antenna varied between 1 and 4m and EUT was rotated a full revolution in order to obtain the maximum value of the electric field strength. The measurements were performed for both vertical (angle of loop antenna: 0deg., 45deg., 90deg. and 135deg.) and horizontal antenna polarization with the Test Receiver, or the Spectrum Analyzer. The measurements were made with the following detector function of the test receiver and the Spectrum analyzer (in linear mode). The test was made with the detector (RBW/VBW) in the following table. When using Spectrum analyzer, the test was made with adjusting span to zero by using peak hold.

Test Antennas are used as below;

Frequency	Below 30MHz	30MHz to 300MHz	300MHz to 1GHz	Above 1GHz
Antenna Type	Loop	Biconical	Logperiodic	Horn

Frequency	From 9kHz to 90kHz and From 110kHz to 150kHz	From 90kHz to 110kHz	From 150kHz to 490kHz	From 490kHz to 30MHz	From 30MHz to 1GHz	Above 1GHz	
Instrument used	Test Receiver					Spectrum Analyzer	
Detector	PK/AV	QP	PK/AV	QP	QP	PK	AV
IF Bandwidth	200Hz	200Hz	9kHz	9kHz	120kHz	RBW: 1MHz VBW: 3MHz	RBW: 1MHz VBW: 10Hz

The test was made on EUT at the normal use position.

* FCC Part 15 Section 15.31 (f)(2) / IC RSS-Gen 4.11 (9kHz-30MHz)

$$9\text{kHz} - 490\text{kHz} [\text{Limit at } 3\text{m}] = [\text{Limit at } 300\text{m}] - 40\log\left(\frac{3}{300}\right)$$

$$490\text{kHz} - 30\text{MHz} [\text{Limit at } 3\text{m}] = [\text{Limit at } 30\text{m}] - 40\log\left(\frac{3}{30}\right)$$

Measurement range : 0.09M-1GHz
Test data : APPENDIX
Test result : Pass

*The test was performed at a distance of 3m since carrier level was low.

UL Japan, Inc.

Head Office EMC Lab.

4383-326 Asama-cho, Ise-shi, Mie-ken 516-0021 JAPAN

Telephone : +81 596 24 8116

Facsimile : +81 596 24 8124

SECTION 7: Other test

Test	Span	RBW	VBW	Sweep	Detector	Trace	Instrument used
20dB Bandwidth	100kHz	1kHz	3kHz	Auto	Peak	Max Hold	Spectrum Analyzer
99% Occupied Bandwidth	Enough width to display 20dB Bandwidth	1 to 3% of Span	Three times of RBW	Auto	Sample	Single	Spectrum Analyzer
Frequency Tolerance	-	-	-	-	-	-	Frequency counter

Test data : APPENDIX
 Test result : Pass

Figure 1: Direction of the Loop Antenna

Side View (Vertical)

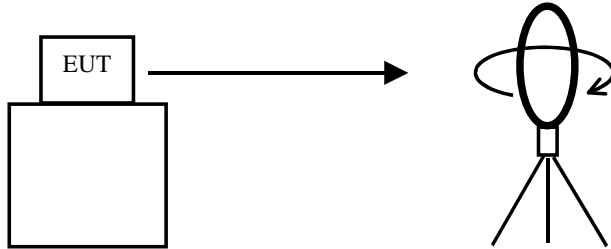

Top View (Horizontal)

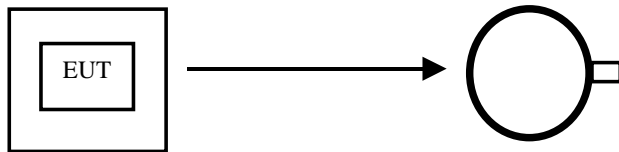

Antenna was not rotated.

Top View (Vertical)

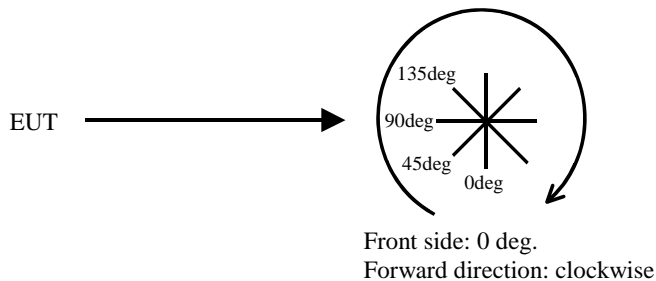

APPENDIX 1: Data of EMI test

Conducted emission

DATA OF CONDUCTED EMISSION TEST

UL Japan, Inc. Head Office EMC Lab. No.4 Semi Anechoic Chamber
Date : 2012/02/07

Report No. : 32EE0060-HO
 Power : AC 120V / 60Hz
 Temp./Humi. : 21deg. C / 31% RH
 Engineer : Hiroshi Kukita

Mode / Remarks : Transmitting (Tx and Rx) mode

LIMIT : FCC15.207 QP
 FCC15.207 AV

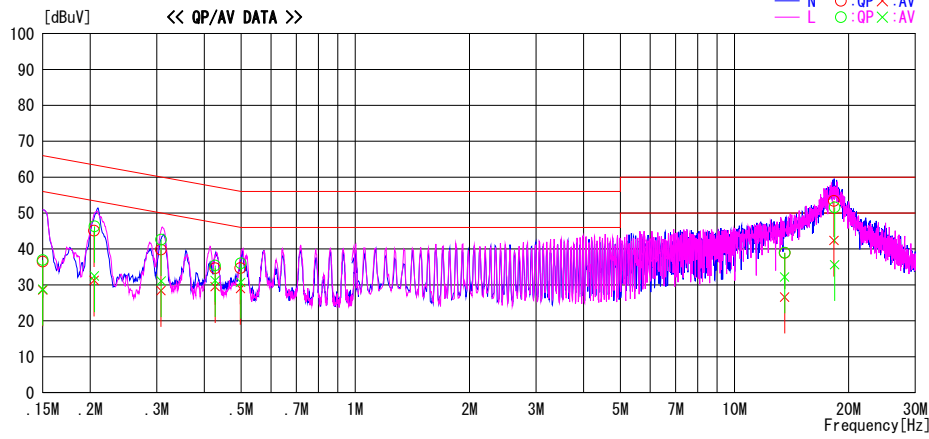

Frequency [MHz]	Reading Level		Corr. Factor [dB]	Results		Limit		Margin		Phase	Comment
	QP [dBuV]	AV [dBuV]		QP [dBuV]	AV [dBuV]	QP [dBuV]	AV [dBuV]	QP [dB]	AV [dB]		
0.15000	23.2	15.3	13.3	36.5	28.6	66.0	56.0	29.5	27.4	N	
0.15000	23.6	15.5	13.3	36.9	28.8	66.0	56.0	29.1	27.2	L	
0.20501	31.8	18.0	13.3	45.1	31.3	63.4	53.4	18.3	22.1	N	
0.20530	33.0	19.2	13.3	46.3	32.5	63.4	53.4	17.1	20.9	L	
0.30768	26.5	15.1	13.3	39.8	28.4	60.0	50.0	20.2	21.6	N	
0.30785	29.3	17.8	13.3	42.6	31.1	60.0	50.0	17.4	18.9	L	
0.42729	22.1	17.9	13.3	35.4	31.2	57.3	47.3	21.9	16.1	L	
0.42748	21.3	16.2	13.3	34.6	29.5	57.3	47.3	22.7	17.8	N	
0.49849	21.4	15.7	13.3	34.7	29.0	56.0	46.0	21.3	17.0	N	
0.49920	22.7	17.4	13.3	36.0	30.7	56.0	46.0	20.0	15.3	L	
13.56000	24.4	17.6	14.6	39.0	32.2	60.0	50.0	21.0	17.8	L	
13.56000	24.3	12.0	14.6	38.9	26.6	60.0	50.0	21.1	23.4	N	
18.30214	38.8	27.8	14.6	53.4	42.4	60.0	50.0	6.6	7.6	N	
18.36200	36.9	20.9	14.7	51.6	35.6	60.0	50.0	8.4	14.4	L	

CHART: WITH FACTOR, Peak hold data. CALCULATION: RESULT=READING+C.F (LISN LOSS+ATT LOSS +CABLE LOSS)
Except for the above table : adequate margin data below the limits.

*The test result is rounded off to one or two decimal places, so some differences might be observed.

Fundamental emission and Spectrum Mask

DATA OF RADIATED EMISSION TEST

UL Japan, Inc. Head Office EMC Lab. No.2 Semi Anechoic Chamber
Date : 2012/02/07

Report No. : 32EE0060-HO
 Power : AC 120V / 60Hz
 Temp./ Humi. : 23deg. C / 32% RH
 Engineer : Hiroshi Kukita

Mode / Remarks : Transmitting (Tx and Rx) mode

LIMIT : FCC15.225 3m, 9-90kHz:PK, 110-490kHz:PK, other:QP
 FCC15.225 3m, 9-90kHz:AV, 110-490kHz:AV, other:QP

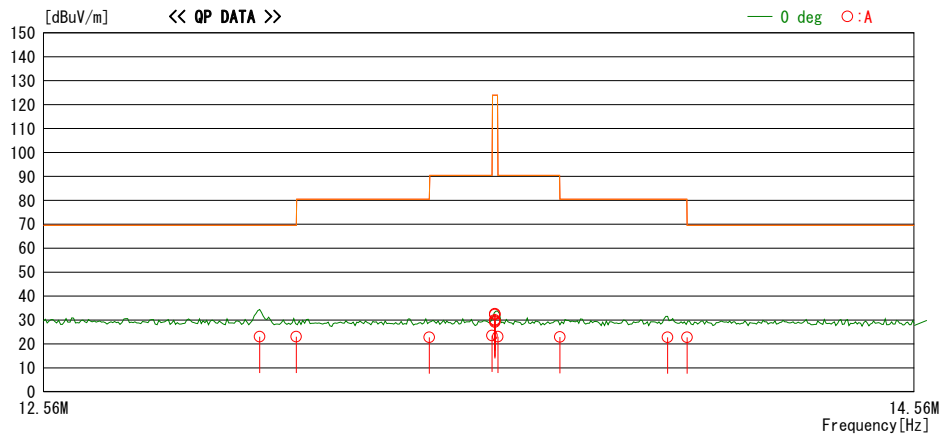

Freq.	Reading	DET	Ant. Fac	Loss	Gain	Result	Limit	Margin	Antenna	Table	Comment
[MHz]	[dBuV]		[dB/m]	[dB]	[dB]	[dBuV/m]	[dBuV/m]	[dB]	[deg]	[deg]	
13.02897	29.2	QP	19.2	6.9	32.2	23.1	69.5	46.4	0	A	322
13.11000	29.2	QP	19.1	6.9	32.2	23.0	69.5	46.5	0	A	2
13.41000	29.1	QP	19.0	6.9	32.2	22.8	80.5	57.7	0	A	22
13.55300	29.9	QP	18.9	6.9	32.2	23.5	90.4	66.9	0	A	332
13.56000	35.5	QP	18.9	6.9	32.2	29.1	123.9	94.8	0	A	270
13.56000	39.0	QP	18.9	6.9	32.2	32.6	123.9	91.3	0	A	332
13.56000	38.7	QP	18.9	6.9	32.2	32.3	123.9	91.6	45	A	293
13.56000	36.0	QP	18.9	6.9	32.2	29.6	123.9	94.3	90	A	266
13.56000	36.4	QP	18.9	6.9	32.2	30.0	123.9	93.9	135	A	108
13.56700	29.4	QP	18.9	6.9	32.2	23.0	90.4	67.4	0	A	332
13.71000	29.2	QP	18.9	7.0	32.2	22.9	80.5	57.6	0	A	321
13.96312	29.2	QP	18.8	7.0	32.2	22.8	80.5	57.7	0	A	321
14.01000	29.2	QP	18.8	7.0	32.2	22.8	69.5	46.7	0	A	247

CHART : WITH FACTOR , ANT TYPE: LOOP Except for the data below : adequate margin data below the limits.
 CALCULATION : RESULT = READING + ANT FACTOR + LOSS (CABLE + ATTEN.) - GAIN (AMP.)

*The test result is rounded off to one or two decimal places, so some differences might be observed.

Spurious emission

DATA OF RADIATED EMISSION TEST

UL Japan, Inc. Head Office EMC Lab. No.2 Semi Anechoic Chamber
 Date : 2012/02/07

Report No. : 32EE0060-HO
 Power : AC 120V / 60Hz
 Temp./ Humi. : 23deg. C / 32% RH
 Engineer : Hiroshi Kukita

Mode / Remarks : Transmitting (Tx and Rx) mode

LIMIT : FCC15.225 3m, 9-90kHz:PK, 110-490kHz:PK, other:QP
 FCC15.225 3m, 9-90kHz:AV, 110-490kHz:AV, other:QP

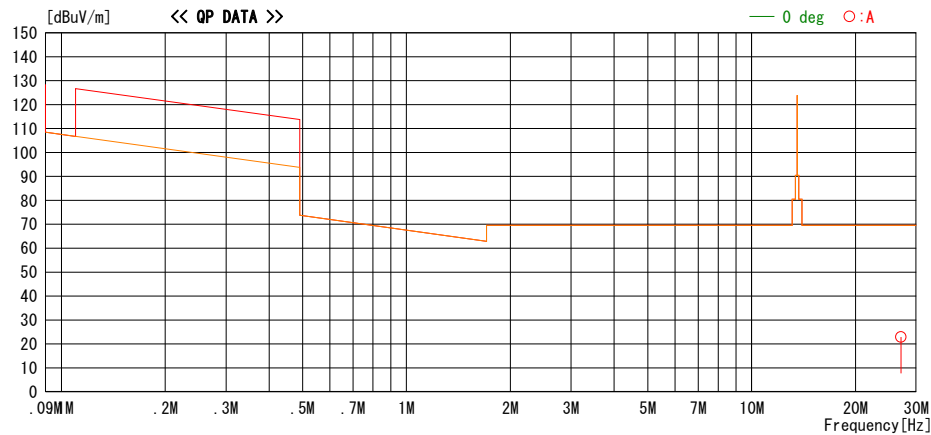

Freq.	Reading	DET	Ant. Fac	Loss	Gain	Result	Limit	Margin	Antenna	Table	Comment
[MHz]	[dBuV]		[dB/m]	[dB]	[dB]	[dBuV/m]	[dBuV/m]	[dB]	[deg]	[deg]	
27.12000	28.6	QP	18.9	7.5	32.1	22.9	69.5	46.6	0	A	

CHART: WITH FACTOR, ANT TYPE: LOOP Except for the data below : adequate margin data below the limits.
 CALCULATION : RESULT = READING + ANT FACTOR + LOSS(CABLE + ATTEN.) - GAIN(AMP.)

*The test result is rounded off to one or two decimal places, so some differences might be observed.

Spurious emission

DATA OF RADIATED EMISSION TEST

UL Japan, Inc. Head Office EMC Lab. No.2 Semi Anechoic Chamber
Date : 2012/02/07

Report No. : 32EE0060-HO
Power : AC 120V / 60Hz
Temp./Humi. : 23deg. C / 32% RH
Engineer : Hiroshi Kukita

Mode / Remarks : Transmitting (Tx and Rx) mode

LIMIT : FCC15.209 3m, below 1GHz:QP, above 1GHz:PK
Except for the data below : adequate margin data below the limits.

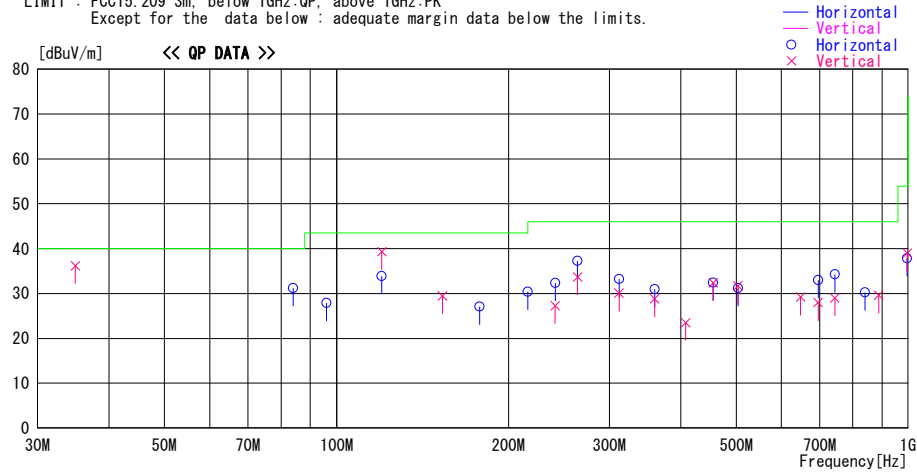

Frequency [MHz]	Reading [dBuV]	DET	Antenna		Level [dBuV/m]	Angle [Deg]	Height [cm]	Polar.	Limit [dBuV/m]	Margin [dB]	Comment
			Factor [dB/m]	Loss& Gain [dB]							
34.938	45.4	QP	16.2	-25.4	36.2	70	100	Vert.	40.0	3.8	*1)
84.041	49.2	QP	6.8	-24.8	31.2	276	238	Hori.	40.0	8.8	
96.046	43.9	QP	8.8	-24.8	27.9	275	189	Hori.	43.5	15.6	
119.998	51.2	QP	12.6	-24.5	39.3	339	100	Vert.	43.5	4.2	*1)
119.998	45.8	QP	12.6	-24.5	33.9	325	153	Hori.	43.5	9.6	*1)
153.190	38.7	QP	15.0	-24.2	29.5	34	100	Vert.	43.5	14.0	
177.810	35.1	QP	16.0	-24.0	27.1	311	110	Hori.	43.5	16.4	
215.998	37.5	QP	16.6	-23.7	30.4	311	149	Hori.	43.5	13.1	
241.240	33.8	QP	17.2	-23.7	27.3	225	100	Vert.	46.0	18.7	
241.414	38.8	QP	17.2	-23.7	32.3	322	100	Hori.	46.0	13.7	
263.996	39.5	QP	17.8	-23.6	33.7	44	100	Vert.	46.0	12.3	*1)
263.996	43.1	QP	17.8	-23.6	37.3	298	160	Hori.	46.0	8.7	*1)
311.996	38.6	QP	14.8	-23.3	30.1	0	100	Vert.	46.0	15.9	
311.995	41.7	QP	14.8	-23.3	33.2	292	100	Hori.	46.0	12.8	*1)
359.994	35.5	QP	16.3	-23.0	28.8	52	116	Vert.	46.0	17.2	
359.994	37.7	QP	16.3	-23.0	31.0	303	100	Hori.	46.0	15.0	
407.994	28.8	QP	17.4	-22.7	23.5	0	131	Vert.	46.0	22.5	
455.993	37.1	QP	17.9	-22.6	32.4	315	170	Vert.	46.0	13.6	
455.991	37.1	QP	17.9	-22.6	32.4	225	100	Hori.	46.0	13.6	
503.992	35.6	QP	18.4	-22.3	31.7	300	100	Vert.	46.0	14.3	
503.993	35.1	QP	18.4	-22.3	31.2	297	100	Hori.	46.0	14.8	
647.988	30.9	QP	20.2	-21.9	29.2	291	117	Vert.	46.0	16.8	
695.988	34.1	QP	20.7	-21.8	33.0	307	100	Hori.	46.0	13.0	*1)
695.988	29.1	QP	20.7	-21.8	28.0	277	100	Vert.	46.0	18.0	
743.989	34.3	QP	21.4	-21.4	34.3	44	100	Hori.	46.0	11.7	*1)
743.987	29.0	QP	21.4	-21.4	29.0	141	100	Vert.	46.0	17.0	
839.985	28.6	QP	22.1	-20.5	30.2	109	100	Hori.	46.0	15.8	

CHART: WITH FACTOR ANT TYPE: -30MHz: LOOP, 30-300MHz: BICONICAL, 300MHz-1000MHz: LOGPERIODIC, 1000MHz-: HORN
CALCULATION: RESULT = READING + ANT FACTOR + LOSS (CABLE+ATTEN.) - GAIN (AMP)

*The test result is rounded off to one or two decimal places, so some differences might be observed.

*1) Spurious emissions is not related to the transceiver but is from the digital device
- with the transceiver powered off the signal remained unchanged.

Spurious emission

DATA OF RADIATED EMISSION TEST

UL Japan, Inc. Head Office EMC Lab. No.2 Semi Anechoic Chamber
Date : 2012/02/07

Report No. : 32EE0060-HO
 Power : AC 120V / 60Hz
 Temp./Humi. : 23deg. C / 32% RH
 Engineer : Hiroshi Kukita

Mode / Remarks : Transmitting (Tx and Rx) mode

LIMIT : FCC15.209 3m, below 1GHz:QP, above 1GHz:PK
 Except for the data below : adequate margin data below the limits.

Frequency [MHz]	Reading [dBuV]	DET	Antenna	Loss&	Level [dBuV/m]	Angle [Deg]	Height [cm]	Polar.	Limit [dBuV/m]	Margin [dB]	Comment
			Factor [dB/m]	Gain [dB]							
996.032	33.8	QP	23.3	-19.3	37.8	260	169	Hori.	53.9	16.1	*1)
887.986	27.5	QP	22.1	-20.0	29.6	0	100	Vert.	46.0	16.4	
995.872	35.0	QP	23.3	-19.3	39.0	0	187	Vert.	53.9	14.9	*1)

CHART:WITH FACTOR ANT TYPE: -30MHz:LOOP, 30-300MHz:BICONICAL, 300MHz-1000MHz:LOGPERIODIC, 1000MHz-:HORN
 CALCULATION:RESULT = READING + ANT FACTOR + LOSS(CABLE+ATTEN.) - GAIN(AMP)

*The test result is rounded off to one or two decimal places, so some differences might be observed.

*1) Spurious emissions is not related to the transceiver but is from the digital device
 - with the transceiver powered off the signal remained unchanged.

20dB Bandwidth

Test place	Head Office EMC Lab. No.2 Semi Anechoic Chamber
Report No.	32EE0060-HO
Date	02/15/2012
Temperature/ Humidity	23 deg.C / 32% RH
Engineer	Hiroshi Kukita
Mode	Transmitting (Tx and Rx) mode

FREQ [MHz]	20dB Bandwidth [kHz]
13.56	2.92

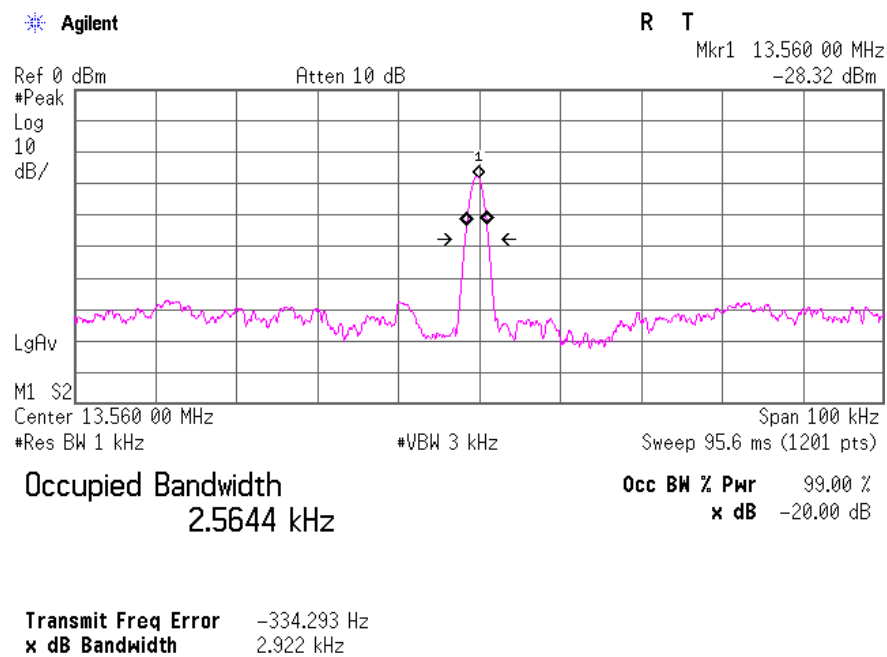

99% Occupied Bandwidth

Test place	Head Office EMC Lab. No.2 Semi Anechoic Chamber
Report No.	32EE0060-HO
Date	02/15/2012
Temperature/ Humidity	23 deg.C / 32% RH
Engineer	Hiroshi Kukita
Mode	Transmitting (Tx and Rx) mode

FREQ [MHz]	99% Occupied Bandwidth [kHz]
13.56	2.17

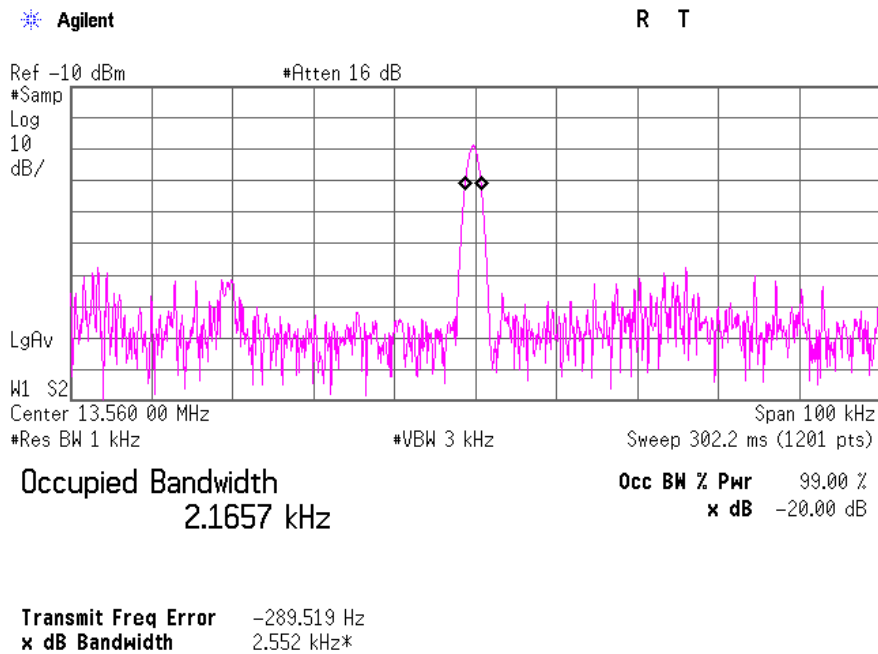

Frequency Tolerance

Test place : Head Office EMC Lab. No.7Shielded room
Report No. : 32EE0060-HO
Date : 01/23/2012
Temperature/ Humidity : 26 deg.C/ 32% RH
Engineer : Satofumi Matsuyama
Mode : Transmitting(Tx and Rx) mode

Test Condition		Test Timing	Measured freq [MHz]	Freq error [MHz]	Result [ppm]	Limit (+/- 0.01%) [+/- ppm]	Margin [ppm]
deg.C	Volts						
20deg.C	276V	Power on	13.55973600	-0.00026400	-19.47	100.00	80.53
		on 2min.	13.55972800	-0.00027200	-20.06	100.00	79.94
		on 5min.	13.55973000	-0.00027000	-19.91	100.00	80.09
		on 10min.	13.55971700	-0.00028300	-20.87	100.00	79.13
	138V	Power on	13.55973600	-0.00026400	-19.47	100.00	80.53
		on 2min.	13.55973200	-0.00026800	-19.76	100.00	80.24
		on 5min.	13.55973000	-0.00027000	-19.91	100.00	80.09
		on 10min.	13.55971700	-0.00028300	-20.87	100.00	79.13
	120V	Power on	13.55973500	-0.00026500	-19.54	100.00	80.46
		on 2min.	13.55972900	-0.00027100	-19.99	100.00	80.01
		on 5min.	13.55972600	-0.00027400	-20.21	100.00	79.79
		on 10min.	13.55971600	-0.00028400	-20.94	100.00	79.06
	102V	Power on	13.55974200	-0.00025800	-19.03	100.00	80.97
		on 2min.	13.55973500	-0.00026500	-19.54	100.00	80.46
		on 5min.	13.55973000	-0.00027000	-19.91	100.00	80.09
		on 10min.	13.55972100	-0.00027900	-20.58	100.00	79.42
	85V	Power on	13.55973600	-0.00026400	-19.47	100.00	80.53
		on 2min.	13.55972700	-0.00027300	-20.13	100.00	79.87
		on 5min.	13.55972100	-0.00027900	-20.58	100.00	79.42
		on 10min.	13.55971600	-0.00028400	-20.94	100.00	79.06
50deg.C.	120V	Power on	13.55967000	-0.00033000	-24.34	100.00	75.66
		on 2min.	13.55966100	-0.00033900	-25.00	100.00	75.00
		on 5min.	13.55965200	-0.00034800	-25.66	100.00	74.34
		on 10min.	13.55964200	-0.00035800	-26.40	100.00	73.60
40deg.C.	120V	Power on	13.55967800	-0.00032200	-23.75	100.00	76.25
		on 2min.	13.55966600	-0.00033400	-24.63	100.00	75.37
		on 5min.	13.55965600	-0.00034400	-25.37	100.00	74.63
		on 10min.	13.55965000	-0.00035000	-25.81	100.00	74.19
30deg.C.	120V	Power on	13.55971100	-0.00028900	-21.31	100.00	78.69
		on 2min.	13.55969700	-0.00030300	-22.35	100.00	77.65
		on 5min.	13.55968500	-0.00031500	-23.23	100.00	76.77
		on 10min.	13.55967900	-0.00032100	-23.67	100.00	76.33
20deg.C.	120V	Power on	13.55974400	-0.00025600	-18.88	100.00	81.12
		on 2min.	13.55973100	-0.00026900	-19.84	100.00	80.16
		on 5min.	13.55972100	-0.00027900	-20.58	100.00	79.42
		on 10min.	13.55971200	-0.00028800	-21.24	100.00	78.76
10deg.C.	120V	Power on	13.55977400	-0.00022600	-16.67	100.00	83.33
		on 2min.	13.55976100	-0.00023900	-17.63	100.00	82.37
		on 5min.	13.55975200	-0.00024800	-18.29	100.00	81.71
		on 10min.	13.55974900	-0.00025100	-18.51	100.00	81.49
0deg.C.	120V	Power on	13.55979400	-0.00020600	-15.19	100.00	84.81
		on 2min.	13.55979000	-0.00021000	-15.49	100.00	84.51
		on 5min.	13.55978400	-0.00021600	-15.93	100.00	84.07
		on 10min.	13.55978100	-0.00021900	-16.15	100.00	83.85
-10deg.C.	120V	Power on	13.55979300	-0.00020700	-15.27	100.00	84.73
		on 2min.	13.55979600	-0.00020400	-15.04	100.00	84.96
		on 5min.	13.55979700	-0.00020300	-14.97	100.00	85.03
		on 10min.	13.55979600	-0.00020400	-15.04	100.00	84.96
-20deg.C.	120V	Power on	13.55977700	-0.00022300	-16.45	100.00	83.55
		on 2min.	13.55978900	-0.00021100	-15.56	100.00	84.44
		on 5min.	13.55979600	-0.00020400	-15.04	100.00	84.96
		on 10min.	13.55979600	-0.00020400	-15.04	100.00	84.96
-30deg.C.	120V	Power on	13.55974900	-0.00025100	-18.51	100.00	81.49
		on 2min.	13.55975500	-0.00024500	-18.07	100.00	81.93
		on 5min.	13.55977000	-0.00023000	-16.96	100.00	83.04
		on 10min.	13.55977200	-0.00022800	-16.81	100.00	83.19

APPENDIX 2: Test instruments

EMI test equipment

Control No.	Instrument	Manufacturer	Model No	Serial No	Test Item	Calibration Date * Interval(month)
MOS-04	Digital Humidity Indicator	N.T	NT-1800	MOS04	FT	2012/02/06 * 12
MSA-05	Spectrum Analyzer	Advantest	R3273	160400285	FT/CE	2011/11/23 * 12
MCC-64	Coaxial Cable	UL Japan	-	-	FT	2011/03/10 * 12
MLPA-06	Loop Antenna	UL Japan	-	-	FT	Pre Check
MPA-14	Pre Amplifier	SONOMA INSTRUMENT	310	260833	FT	2011/03/04 * 12
MAEC-02	Semi Anechoic Chamber(NSA)	TDK	Semi Anechoic Chamber 3m	DA-06902	RE/CE	2011/06/21 * 12
MOS-22	Thermo-Hygrometer	Custom	CTH-201	0003	RE/CE	2012/02/06 * 12
MJM-14	Measure	KOMELON	KMC-36	-	RE/CE	-
COTS-MEMI	EMI measurement program	TSJ	TEPTO-DV	-	RE/CE	-
MTR-07	Test Receiver	Rohde & Schwarz	ESCI	100635	RE/CE	2011/10/19 * 12
MLPA-01	Loop Antenna	Rohde & Schwarz	HFH2-Z2	100017	RE	2011/10/19 * 12
MCC-13	Coaxial Cable	Fujikura	3D-2W(12m)/5D-2W(5m)/5D-2W(0.8m)/5D-2W(1m)	-	RE	2011/02/18 * 12
MCC-31	Coaxial cable	UL Japan	-	-	RE	2011/07/28 * 12
MAT-07	Attenuator(6dB)	Weinschel Corp	2	BK7970	RE	2011/11/02 * 12
MBA-02	Biconical Antenna	Schwarzbeck	BBA9106	VHA91032008	RE	2011/10/23 * 12
MLA-02	Logperiodic Antenna	Schwarzbeck	USLP9143	201	RE	2011/10/23 * 12
MCC-12	Coaxial Cable	Fujikura/Agilent	-	-	RE	2011/02/18 * 12
MPA-14	Pre Amplifier	SONOMA INSTRUMENT	310	260833	RE	2011/03/04 * 12
MAEC-04	Semi Anechoic Chamber(NSA)	TDK	Semi Anechoic Chamber 3m	DA-10005	CE	2011/03/01 * 12
MOS-15	Thermo-Hygrometer	Custom	CTH-180	-	CE	2012/02/06 * 12
MJM-07	Measure	PROMART	SEN1955	-	CE	-
MLS-06	LISN(AMN)	Schwarzbeck	NSLK8127	8127363	CE(EUT)	2011/02/20 * 12
MLS-07	LISN(AMN)	Schwarzbeck	NSLK8127	8127364	CE(AE)	2011/02/22 * 12
MTA-31	Terminator	TME	CT-01	-	CE	2012/01/11 * 12
MAT-67	Attenuator(13dB)	JFW Industries, Inc.	50FP-013H2 N	-	CE	2012/01/28 * 12
MCC-113	Coaxial cable	Fujikura/Suhner/TSJ	5D-2W(10m)/SFM141(5m)/421-010(1m)/sucoform141-PE(1m)/RFM-E121(Switcher)	-/04178	CE	2011/07/04 * 12
MPA-13	Pre Amplifier	SONOMA INSTRUMENT	310	260834	RE	2011/03/04 * 12
MAT-65	Attenuator(13dB)	JFW Industries, Inc.	50FP-013H2 N	-	CE	2012/01/28 * 12
MCC-13	Coaxial Cable	Fujikura	3D-2W(12m)/5D-2W(5m)/5D-2W(0.8m)/5D-2W(1m)	-	CE	2011/02/18 * 12
KCH-01	Temperature and Humidity Chamber	Tabai Espec	PL-1KT	14007630	FT	2011/04/27 * 12

The expiration date of the calibration is the end of the expired month.

All equipment is calibrated with valid calibrations. Each measurement data is traceable to the national or international standards.

As for some calibrations performed after the tested dates, those test equipment have been controlled by means of an unbroken chains of calibrations.

Test Item: CE: Conducted Emission
RE: Radiated Emission
FT: Frequency Tolerance

UL Japan, Inc.

Head Office EMC Lab.

4383-326 Asama-cho, Ise-shi, Mie-ken 516-0021 JAPAN

Telephone : +81 596 24 8116

Facsimile : +81 596 24 8124