

Card Printer

CHC-C320

Operation manual

SINFONIA TECHNOLOGY CO., LTD.

<http://www.sinfo-t.jp>

Handling of this Manual

1. All rights reserved. No part of this operation manual covered by the copyright herein maybe reproduced or copied in any form or by any means, including translation, without the written permission of SINFONIA TECHNOLOGY Co., Ltd.
2. The specifications in this operation manual are subject to change without prior notice.
3. In case of having any difficulties or finding the fault in this manual, your information to SINFONIA TECHNOLOGY will be highly appreciated.

Introduction

This manual describes detailed instructions for handling of and basic operation of Digital Photo Printer CHC-C320.

We will describe this product as “the printer” in the manual.

Read this manual thoroughly to understand how to install and operate the printer before

Notice

- Keep this manual near the printer and operators can refer to this manual periodically.
- In case, lost or damaged this manual, contact your dealers.
- In the case of transfer, do not forget to put this manual together with the printer.

CONTENTS

PREFACE

PREFACE

Chapter 1. Important Safety Instruction	1-1
Environments	1-1
Handling Instruction	1-2
Handling Instruction for Consumable and Printed Output	1-3
Chapter 2. Installing and Set Up	2-1
Unpacking and Checking the Accessories	2-1
Parts Name and Function	2-2
Printer Status Lamps Name and Printer Status	2-3
Connecting Power Cable	2-4
Connecting USB Cable	2-4
Attaching the cleaning roller	2-5
Setting Color Ink Ribbon	2-6
Setting Hologram Ink Ribbon	2-7
Setting Card	2-8
Transporting the Printer	2-10
Print	2-10
Chapter 3. Routine Maintenance	3-1
Cleaning of Thermal Head, Platen, and Cleaning Roller	3-1
Cleaning of Outer Cover	3-3
Cleaning of Filter	3-3
Chapter 4. Error Handling	4-1
Printer Status lamps are displayed in red	4-1
Failure Symptoms	4-2
Card Jam	4-3
Power Supply Interrupted during Printing	4-7
When the Ribbon is snapped	4-7
Chapter 5. In order to more comfortably use	5-1
For longer Printer usage	5-1
After-sales Service	

Chapter 1. Important Safety Instruction

This manual provides detailed instructions for the safety use of the printer.

Read this manual before operating the printer to ensure to have proper use.

- ◆ In this manual, there are notes that require special attention.
- ◆ For your safety operation, Safety notices are separated as follows:



Warning: Inappropriate handling can cause the death or serious wound.



Caution: Inappropriate handling can cause the wound for the users and/or cause the physical damage.

Attention: Explanation about the cause of the trouble and the environmental condition.

- ◆ It is difficult to forecast all the danger in setting and use of the printer. Therefore, warnings in this Operation Manual, in the other documents on the printer cannot cover all the cases. In case of performing the operation or maintenance which are not described in this manual, all the concern for the safety have to be taken care of at the customer side.
- ◆ Operations and the notification for the maintenance described in this manual and other documents are for the proper use of the printer. In case of using the printer for the other purpose, all the concern for the safety has to be taken care of at the customer side.
- ◆ Do not perform the operation which are prohibited in this manual and other documents.
- ◆ The contents that cannot be printed due to a failure while using the use of this printer are not guaranteed.

Environments

To use the printer safety, please pay attention to the followings:



Caution: Do not let children to touch the printer or the cables. It can cause accidents or electric shock.



Caution: Do not place the printer under humid or dusty place. It can cause a fire, electric shock or printer problem. Do not place the printer with dust, sand and high humidity such as bathing place, bathroom, hot spring, on the street.



Caution: Do not place the printer on rickety place and/or inclined place. Printer may fall down or tumble and it can cause injury.



Warning: Do not insert or fall the metallic items or flammable items into the printer through the openings of the printer, it can cause the fire and electric shock.



Warning: Do not put vase, flowerpot, and cup with water inside or metric items. In case the water spilt or metric items fall into the printer, it can cause the fire and electric shock.



Warning: Do not block the openings of the printer. In case, the opening blocked, the heat will remain inside and it can cause the fire.

Attention: Do not place the printer under the low temperature such as ski resort, skating rink or open-air with direct sunlight.

Chapter 1. Important Safety Instruction

Handling Instruction

In handling the printer, please pay attention to the followings;



Warning: Lift the printer from its box and put it onto a flat table or desk.



Warning: At nearly 20Kg, the printer is too heavy to be lifted by one person.
Also please take a good care of your hands and fingers when lifting the printer from the box.



Warning: Be careful when you transport the printer on the slippery floor.



Warning: In case you drop the printer, firstly turn off the power of the printer and remove the power cable, then contact the dealers or service center. To use the printer without any checking, can cause the fire or electric shock.



Warning: Secure the power cable firmly.



Warning: This product must be grounded, and always used with only the specified power cable or the power cable accompanying this product.
If the product is used without ground, and current leakage occurs, fire or electrical shock is most likely to result, and also cause signal-receiving interference to a radio, a television receiver, and other similar electric appliances.
If the proper grounding connection is not possible, please contact to the dealers or service center.



Warning: Do not attempt to service the printer beyond the instruction specified in this document. In case, impossible to recover from the problem, please contact to the dealers or service center.



Warning: The thermal head reaches high temperature during operation but this is normal. Do not touch the thermal head.



Warning: Do not dismantle or remodel the printer.
Some sections of the printer contain a high voltage or become very hot. Ignoring this warning may cause electric shock, fire, or burns.



Warning: Printed cards are out fast from paper outlet. So do not look into the paper outlet. It can cause the blindness or injury.



Warning: When a fan motor fails, it can cause a fire. At exchange, please ask the dealers or service center.

Attention: Touching the surface of the thermal directly can cause the damage to thermal head. When a hard object get into the printer, it can cause the damage to the printer mechanism. In such case, please do not use the printer.

Attention: At installation, appropriate interface cable will be required with your computer.

Chapter 1. Important Safety Instruction

Handling Instruction for Consumable and Printed Output

In handling the ink ribbon, card and printed output, please pay attention to the followings:

Attention: Card Handling

- Use the card specified by SINFONIA TECHNOLOGY.
- Store the card flat.
- Store the card in a dry and dark place to avoid the direct Sunlight.
(Temperature less than 30°C, Humidity less than 60%).
- Do not touch the card surface before

Attention: Ink Ribbon Handling

- Use the ink ribbon specified by SINFONIA TECHNOLOGY.
- Store the ink ribbon in cool place to avoid the direct sunlight.
(Temperature less than 30°C, Humidity less than 60%)

Attention: Printed Output Handling

- Store the printed output in a dark place to avoid the direct sunlight.
- Store the printed output away from the organic fluid such as benzene, thinner and alcohol which may change or deteriorate the colors.



Caution: When abandon the ink ribbon, please handle it as harmful industrial waste.



Caution: Be careful not to injure your hands with the card edge when handling card.

Chapter 2. Installing and Set Up

This chapter explains the unpacking and set up of the printer. Before proceeding to this chapter, please make sure to read Chapter 1. Important Safety Instruction.

Unpacking and Checking the Accessories

1. Open the box and remove the box containing the accessories and protection materials.

Attention: Keep the packaging materials. The box and protection materials are necessary when moving or

2. Take out the printer by holding bottom of the printer.

Caution: This printer weighs about 20Kg. Please handle it carefully. When lifting the printer, always hold bottom of printer. Otherwise, the printer may be damaged.

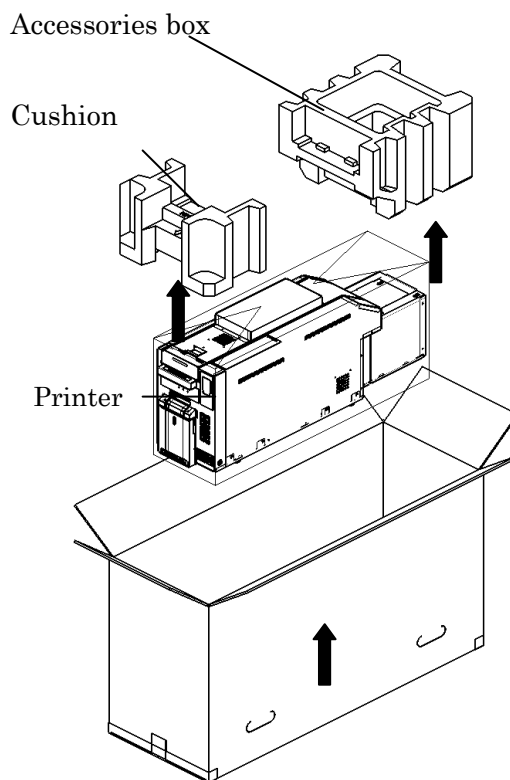
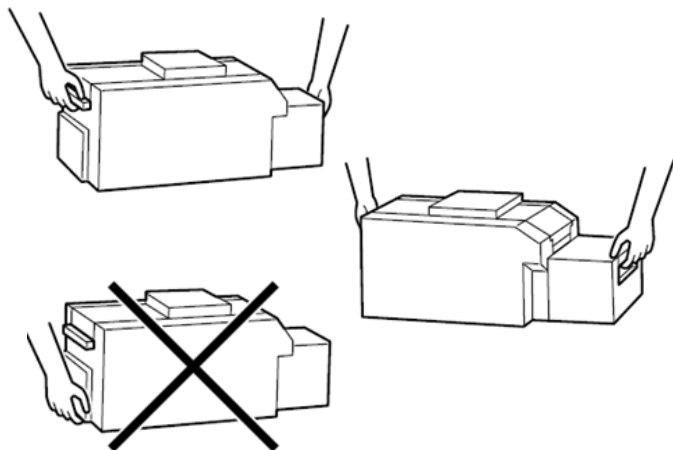

3. Take out the accessories from the accessory box and check the contents.

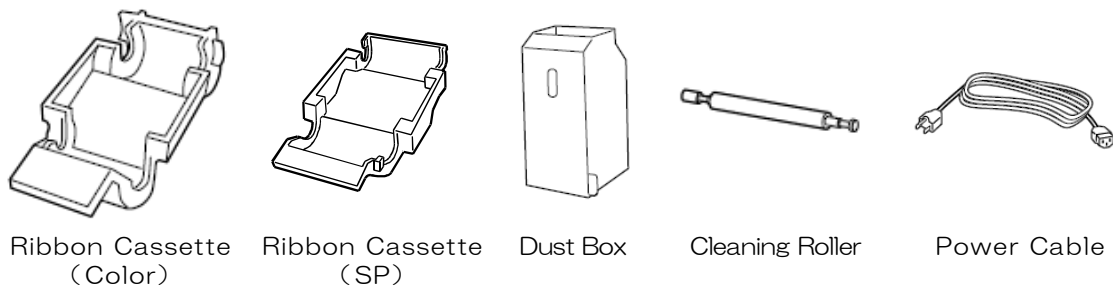

Chapter 2. Installing and Set Up

Parts Name and Function

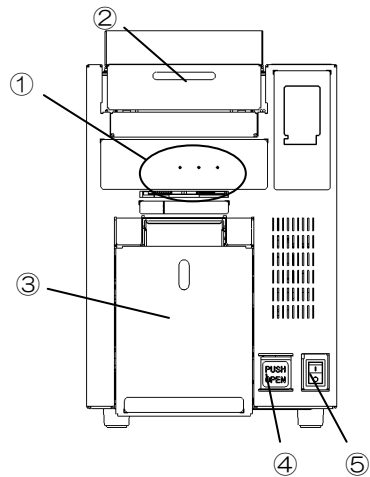

(Front View)

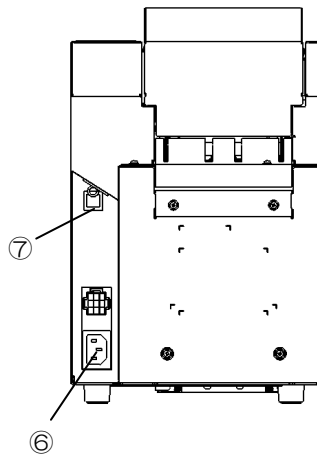

(Rear View)

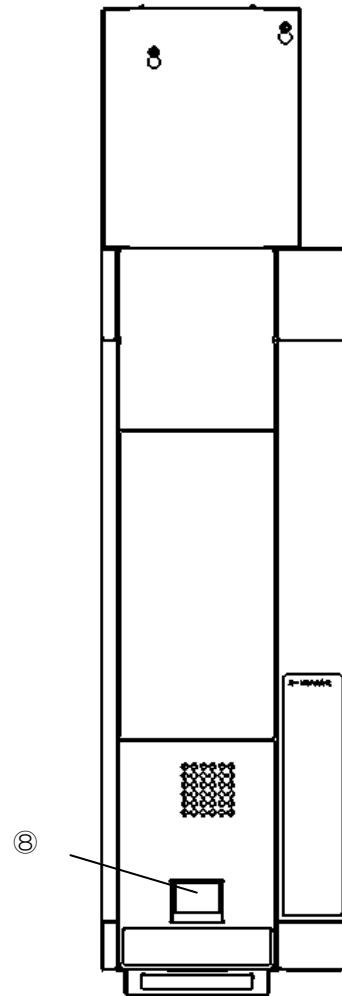

(Upper View)

No.	Name	Function
①	Printer Status Indicator	Printer status display lamps are located on the panel.
②	Upper Unit	Open the upper unit when replacing an ink ribbon or card, or when performing maintenance.
③	Card set unit	Open the card set unit when card setting, or when performing maintenance.
④	Card set unit open button	When open the card set unit, push this button.
⑤	Power Switch	This switch turns on/off the power of the printer. When the “ ” marked side of the switch is pressed, the power is turned on. When the “o” marked side of the switch is pressed, the power is turned off. <Caution> Once the printer is turned off, wait at least 3 seconds before turning it on again.
⑥	Power Connector	To be used to connect the power cable.
⑦	USB Connector	To be used to connect the USB cable.
⑧	Upper Unit Open Lever	When open the open guide unit, hold this lever.

Chapter 2. Installing and Set Up

Printer Status Lamps Name and Printer Status

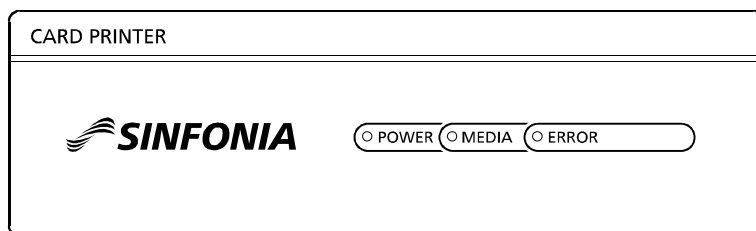

LED Display			Description
POWER	MEDIA	ERROR	
○	○	○	The power of printer is off.
*	○	○	The printer is initializing after turn on the power Thermal head is cooled/heated on printing.
●	○	○	The printer is ready to make prints.
●	○	*	The card set unit or upper unit are opened.
●	○	●	Card jammed in printer. Mechanical part is faulty. Trouble of printer control board.
●	*	●	The ink ribbon loaded is not supported.
●	●	●	Card is not set. Out of card. The ink ribbon is not loaded. The ink ribbon is empty.
●	*	○	The printer is initializing for the ink ribbon.

Printer status lamp display ●:on, ○:off, *:flashing

Chapter 2. Installing and Set Up

Connecting Power Cable

Insert the power cable attached to the printer into the power connector located on the rear of the printer.

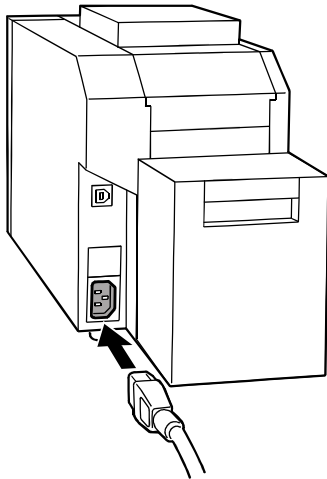

Warning: In case of not using the the power cable for safety.



Warning: Avoid “piled up” connection. It can cause the fire and electric shock.

Connecting USB Cable

Connect the USB cable from the personal computer to the USB connector located on the left rear side of the printer.

Be sure to insert the USB cable all the way.

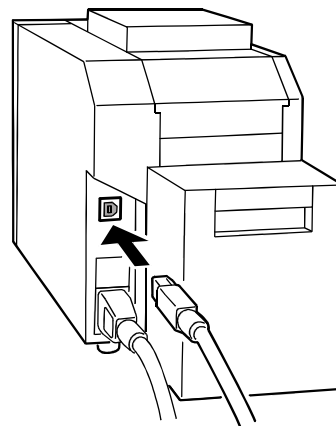

Warning: Make sure to turn off the power of the printer before inserting the power cable.



Warning: Make sure to insert the power cable correctly. If not, it can cause the fire or the printer problem.



Warning: Do not insert or remove the power cable with wet hands. It can cause the electric leakage.



Warning: Do not make any damage or any modification to the power cable. Put the heavy items on the power cable, give a strong pull to the power cable and twist the power cable can cause the fire and electric shock.



Warning: When moving the printer, make sure to turn off the power of the printer, remove the power cable in order to have no connection with other devices. Otherwise, the power cable might be damaged and it can cause the fire and electric shock. Also there is a possibility to fall down caught by the cable.

Attention: To remove the USB cable, make sure that the printer is in the waiting status. Removing the USB cable during data transfer may not be able to print data correctly.

Chapter 2. Installing and Set Up

Attaching the cleaning roller.

1. Pull the upper unit open lever, and open the upper unit.

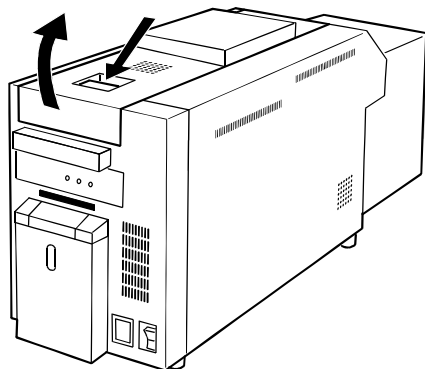

When opening the upper unit, slowly move it upward with pulling the upper unit open lever. And until the upper unit is locked, hold and support the upper unit by hand.



Caution: Until the upper unit is locked, hold and support the upper unit by hand.

2. Place the cleaning roller to the printer.

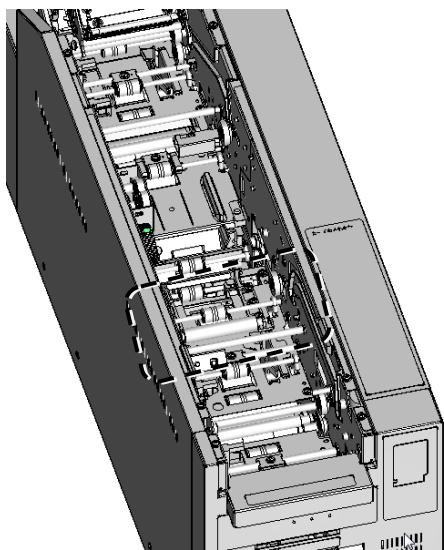

Push the cleaning roller to the place shown in the following figure. (Push the cleaning roller until you hear an audible 'click'.)

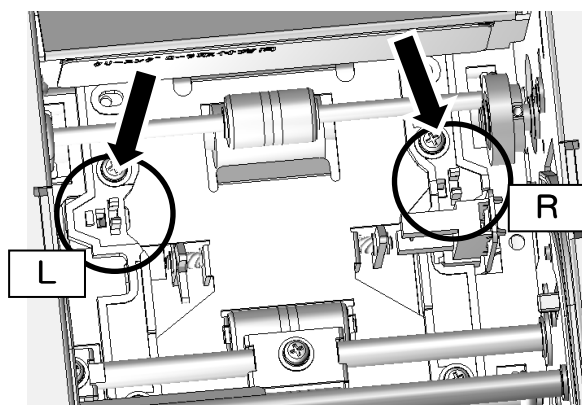

(Direction of the cleaning roller)

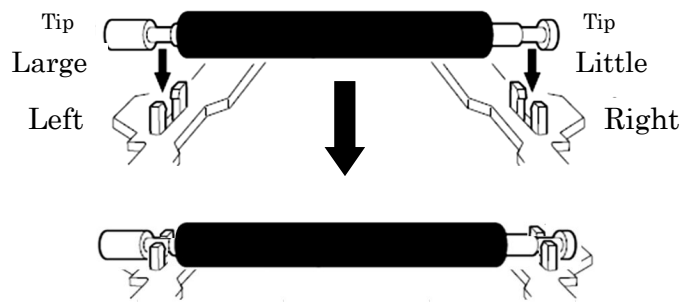

3. Close the upper unit.

Chapter 2. Installing and Set Up

Setting Color Ink Ribbon

1. Pull the upper unit open lever, and open the upper unit.

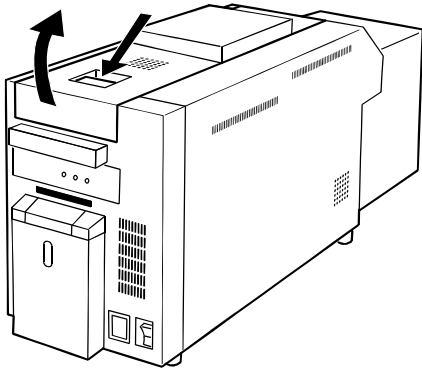

2. Place the ink ribbon to the ribbon cassette.

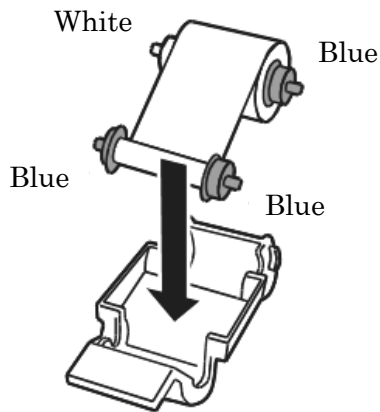

Insert the ribbon into the ribbon cassette until it clicks into position.



Caution: Be careful not to get any dust, etc. on the ink ribbon.

3. Place the ribbon cassette to the printer.

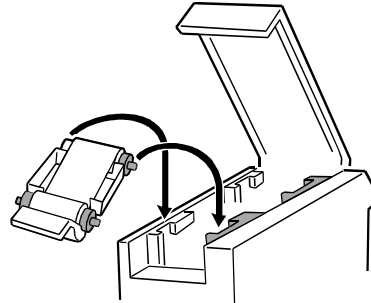

If there is any slack in the ink ribbon, remove it before setting.

(Taking out of the ribbon cassette)

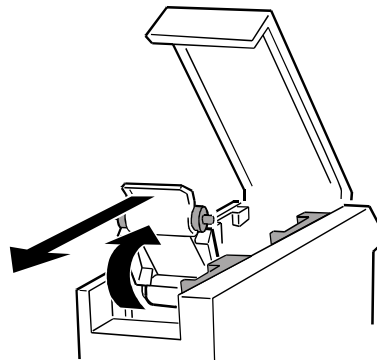

4. Close the upper unit.

Chapter 2. Installing and Set Up

Setting Special Color Ink Ribbon

1. Pull the upper unit open lever, and open the upper unit.

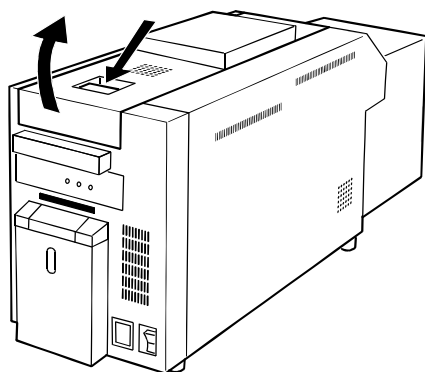

2. Place the ink ribbon to the ribbon cassette.

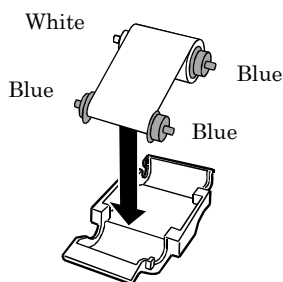

Insert the ribbon into the ribbon cassette until it clicks into position.

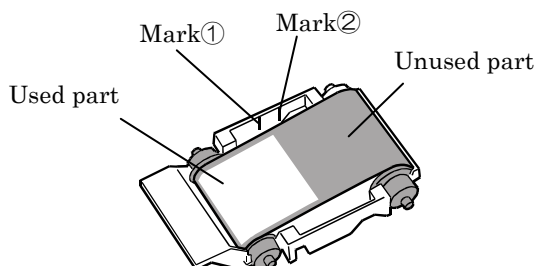

When resetting the used ink ribbon used on the way, please set it in accordance with boundary of the used and unused part in accordance with "Mark 1, 2" of the ribbon cassette.



Caution: Be careful not to get any dust, etc. on the ink ribbon.

3. Place the ribbon cassette to the printer.

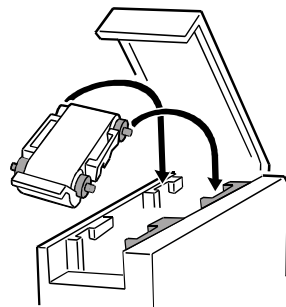

If there is any slack in the ribbon, remove it before setting.

(Taking out of the ribbon cassette)

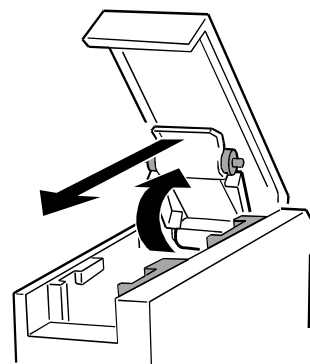

4. Close the upper unit.

Chapter 2. Installing and Set Up

Setting Card

1. Push the card set unit open button, and draw out the card set unit.

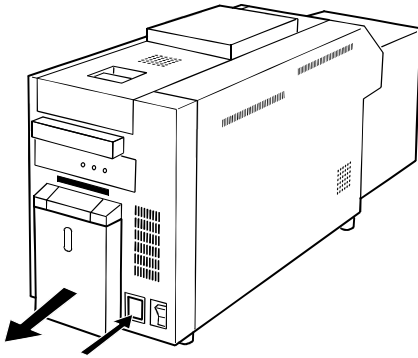

2. Place the dust box to the card set unit.

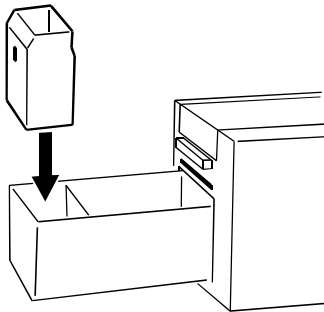

Empty the dust box if there is any trim in it.

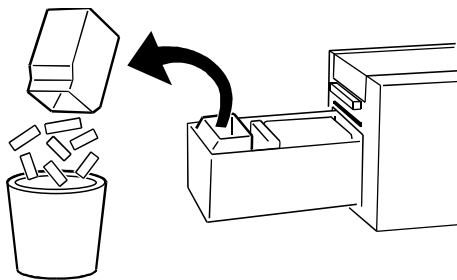

3. Remove only the underside of the card packing film.

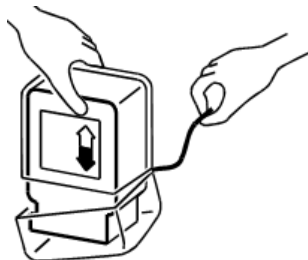

4. While pulling the card guide (blue lever), turn the printing surface on the front side and place it in the printer. And remove the upper side of the packing film.

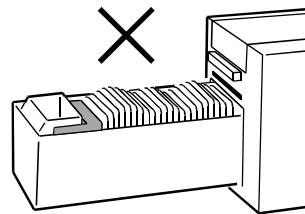
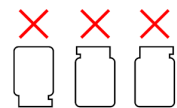
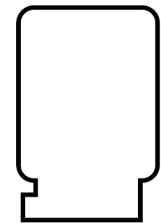
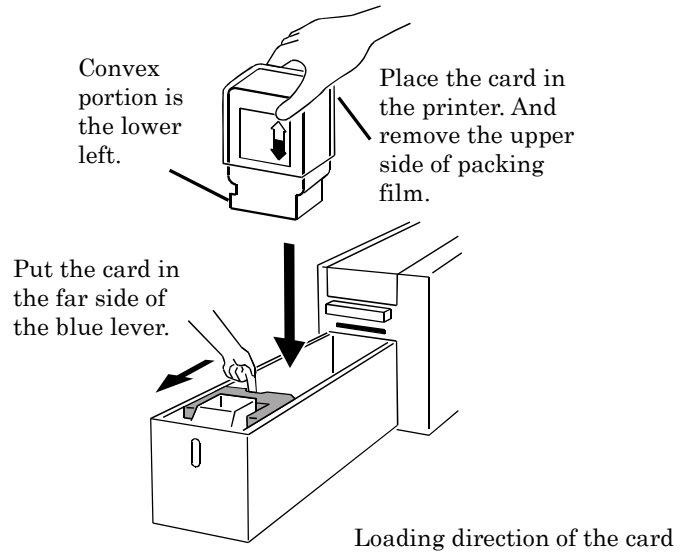

Please arrange the card height in order flatly.

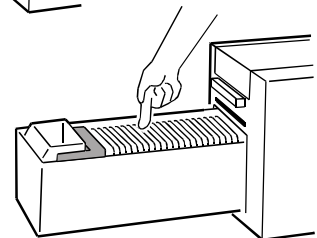

Chapter 2. Installing and Set Up

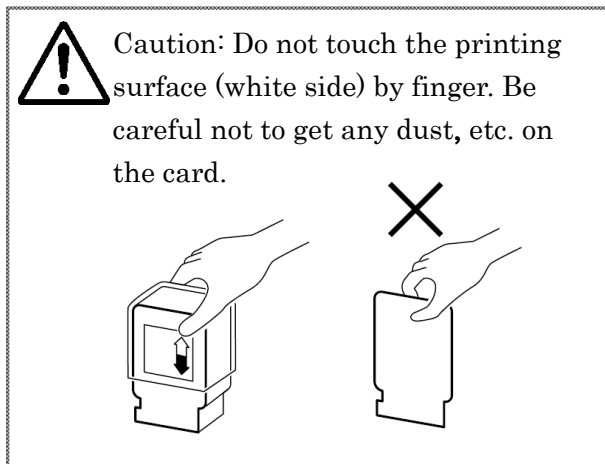

5. Close the card set unit.

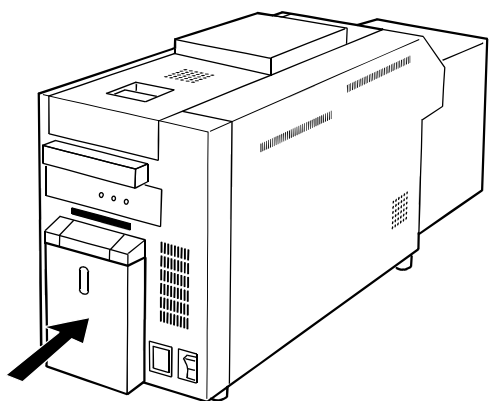

Chapter 2. Installing and Set Up

Transporting the Printer

The following cautions are necessary in transportation of the printer. Since an incorrect transportation method causes a printer fault, follow the correct method.

1. Remove the ink ribbon and card from the printer before transporting the printer. If the ink ribbon or card cannot be removed due to a fault, consult with the distributor.
2. Use a genuine box. If the box used at the purchase cannot be used, consult with your distributor and purchase a new box.

Print

Follow the operation manual of the PC or application software. In addition, please note that we do not guarantee for the print result.

Chapter 3. Routine Maintenance



Caution: Make sure that the power is turned off before starting cleaning. Thermal Head reaches high temperature just after printing. Do not touch directly by hand. Make sure that the thermal head has been sufficiently cooled down before starting cleaning.
When fingerprint stick to the heat element, it can damage the Thermal Head. Do not touch directly by hand.
Be careful not to be hurt by the projections of the printer.

Cleaning of Thermal Head, Platen, and Cleaning Roller

By using thermal transfer technology, daily maintenance is not really necessary if the printer is being use properly.

However, in order to keep the best print quality, it is recommended to do the cleaning of Thermal Head, Platen, and Cleaning Roller once in a month.

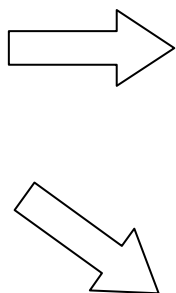
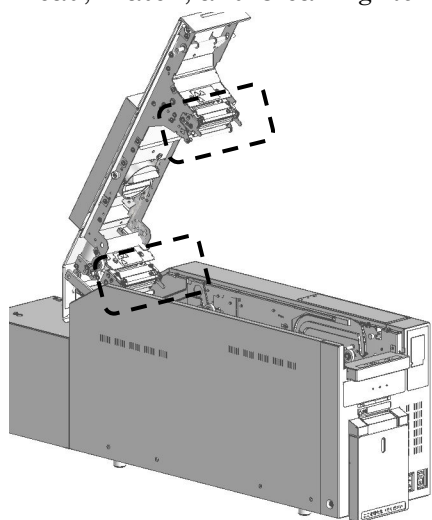

1. Using gauze, clean the heat element (glass bar) of the thermal head with isopropyl alcohol or ethyl alcohol.

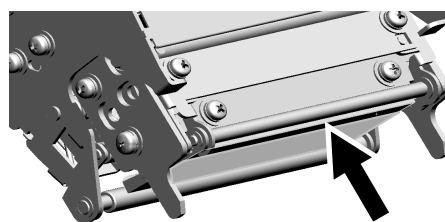

2. Using gauze dipped with isopropyl alcohol or ethyl alcohol, clean the edge of the peeling roller.

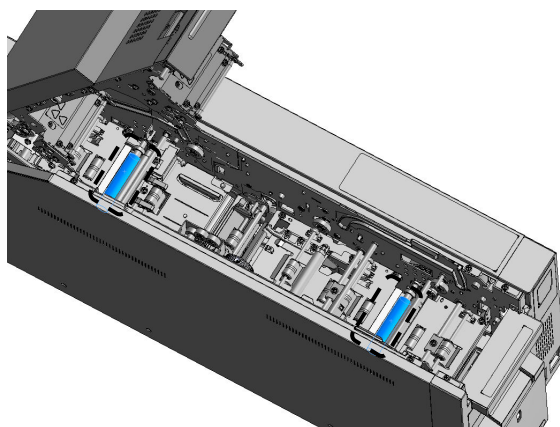
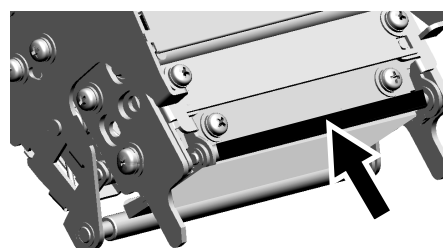

3. Using gauze dipped with isopropyl alcohol or ethyl alcohol, clean the rubber section of the platen roller.

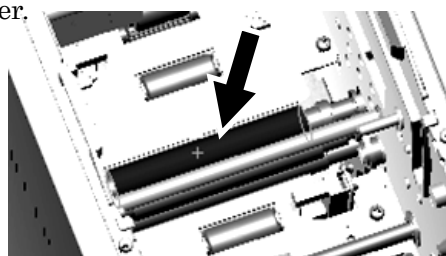

Chapter 3. Routine Maintenance

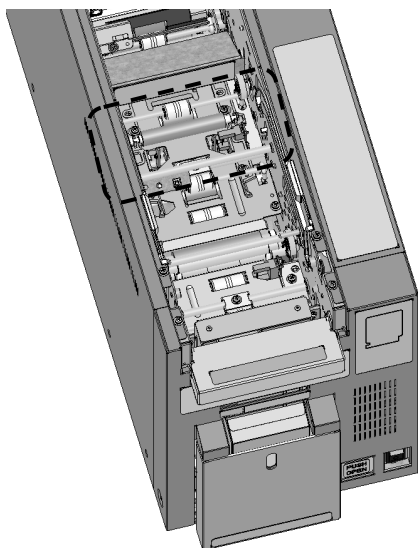

4. Using gauze dipped with isopropyl alcohol or ethyl alcohol, clean the rubber section of the cleaning roller

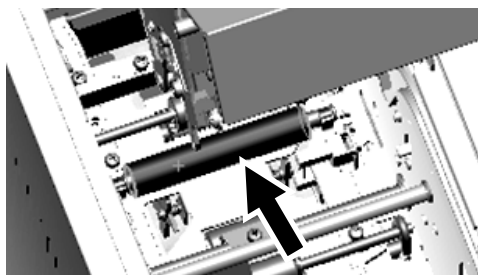

Attention: Printing should be performed after the alcohol dried up completely (approx. 5 minutes)

Chapter 3. Routine Maintenance

Cleaning of Outer Cover

Wipe the printer outer cabinet with a soft cloth.

If the stains are not removed, wet the cloth and apply weakened neutral Detergent to it.



Warning: In case, the foreign substance get into the printer, turn off the power of printer, remove the power cable and contact the dealers or service center. Continuous use of the printer under such condition can cause the fire and electric shock.



Warning: Continuous use under the abnormal condition such as high temperature, smoke and strange smell can cause the fire and electric shock. Turn off the power and make sure to remove the power cable, then contact the dealers or service center.



Caution: Do not use volatile solvents or spray insecticide on the printer outer cabinet. Otherwise, discoloration or crack may result.

Cleaning of Filter

If the dust collects on the openings, clean it with vacuum cleaner

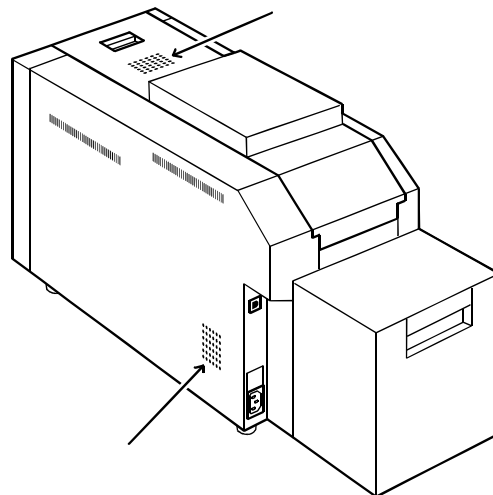

Chapter 4. Error Handling

Printer Status lamps are displayed in red

When the error happens, the details of the error can be confirmed with the printer status lamps.

Printer Status Lamps and Card Setting Lamp display ●:on, ○:off, *:flashing

/ : Indicates that irrespective lit

LED Display			Status	Corrective Action
POWER	MEDIA	ERROR		
●	○	*	The card set unit or the upper unit are opened.	Close the card set unit and the upper unit.
●	○	●	Card jam occurred.	Remove the card. If card jam occurs frequently, consult with the service center.
			Trouble of printer control board. The printer mechanical section is faulty.	If it occurs frequently, consult with the service center.
●	*	●	The ink ribbon set is not supported.	Ink ribbon or printer abnormality is assumed. Consult with the Service Department.
●	●	●	Trim box is full.	Empty the trim box.
			The card is not set. Card empty.	Set the card.
			The ink ribbon is not loaded. Ribbon empty.	Set the ink ribbon. Replace the ink ribbon.
●	*	○	The ink ribbon is during the initial setting.	Wait the initial setting of the ink ribbon is complete.

Chapter 4. Error Handling

Failure Symptoms

When detecting a failure symptom, check the printer using the following table.

Symptom	Action
Power is not turned on.	<ul style="list-style-type: none">• Check if the power cable is connected to the plug socket or the printer.
The personal computer does not recognize the printer.	<ul style="list-style-type: none">• Check if the USB cable is connected to the personal computer or printer.
The printer does not become ready.	<ul style="list-style-type: none">• Check if the card set unit and the upper unit are closed.• Check if card is jammed in the printer.• When the card setting lamp is blinking, remove the edge of the card until the card setting lamp goes off.
The card set unit does not open.	<ul style="list-style-type: none">• Check if the printer is installed in a flat location.• Check if any object is placed in front of the front cover.
A straight stripe area is not printed.	<ul style="list-style-type: none">• The thermal head may be dirty. Clean the thermal head as described in Chapter 3, "Routine Maintenance".• If the blank area remains after cleaning the thermal head, the head may have been disconnected. Consult with the Service Department.
Dotted areas are not printed.	<ul style="list-style-type: none">• The cleaning roller may be dirty. Clean the thermal head as described in Chapter 3, "Routine Maintenance".

Chapter 4. Error Handling

Card Jam

1. Open the upper unit, and remove the ribbon cassette.
2. Confirm the card jamming position and remove the card according to the following procedure.



Warning: When removing the card, do not pull the card strongly not to be injured by the part of the printer.



Warning: Please abrogate the removed card without reuse. It may cause card jam or printer damage.

Attention: when the same symptoms occur frequently, contact the after-sales service department.

(When there is a card around the center of the printer and it is vertical as shown in the following figure.)

- Turn the knob(green) of the left side of the printer, move the card to the upper and pull it to upward and remove.

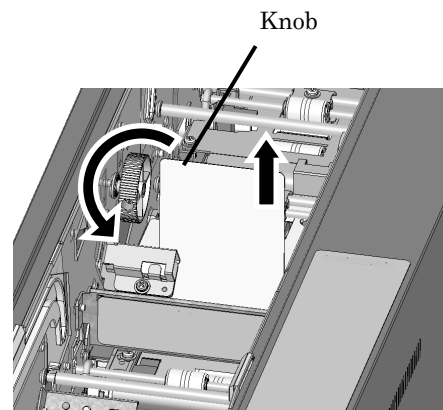
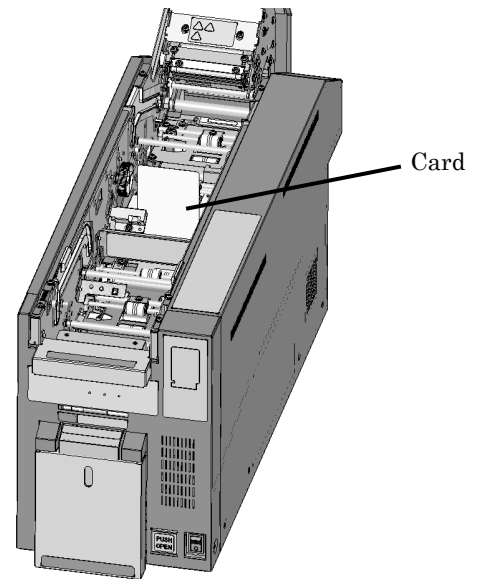

Chapter 4. Error Handling

(When there is a card around the printer center and it is horizontal as shown in the figure.)

- 1) Turn the knob (green) of the left side of the printer, and move the card to the front side.

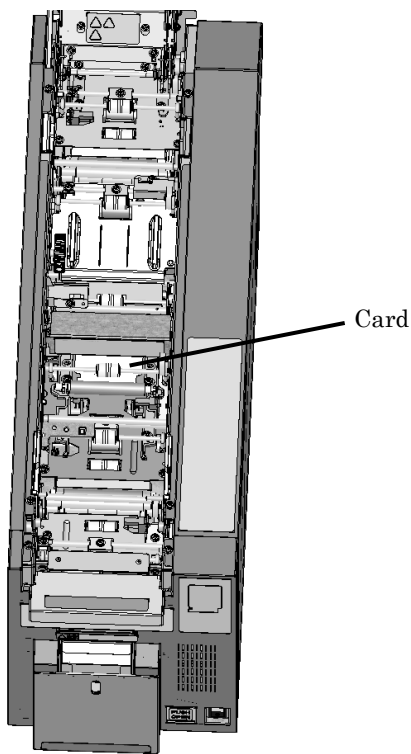

- 2) If the card move to the position shown in the following figure, pick up the top of the card and pull it up (as tilt it slightly forward) , and remove it.

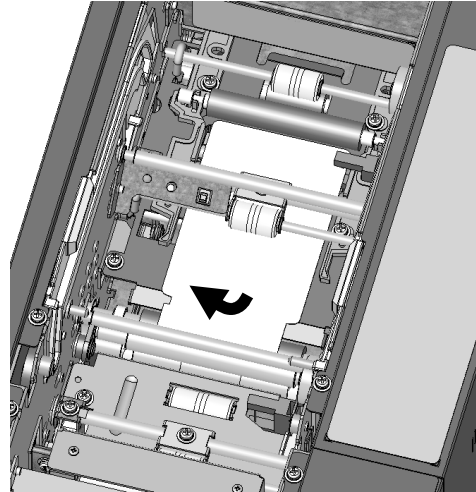

(When there is the card at front part of the printer).

- 1) Move the card by finger to the position shown in the following figure.

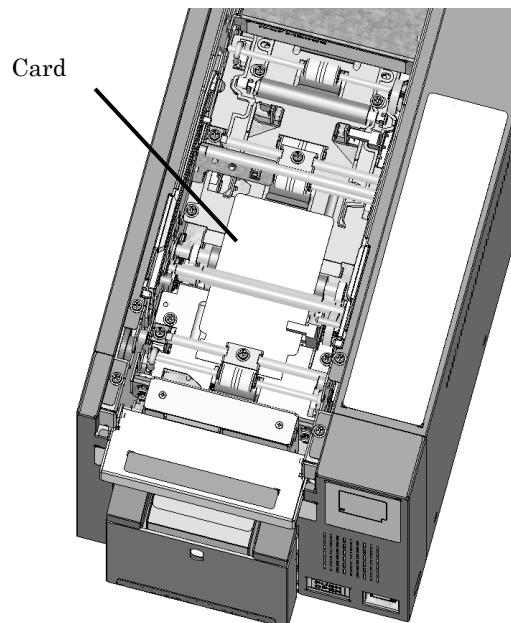
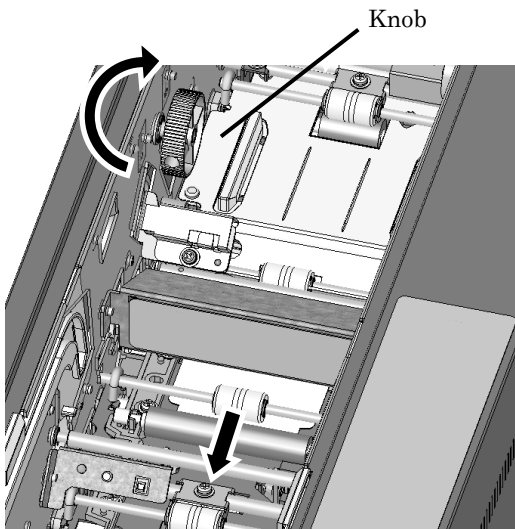

Chapter 4. Error Handling

2) If the card move to the position as shown in the following figure, pick up the end of the card and pull it up (as tilt it slightly backward) , and remove it.

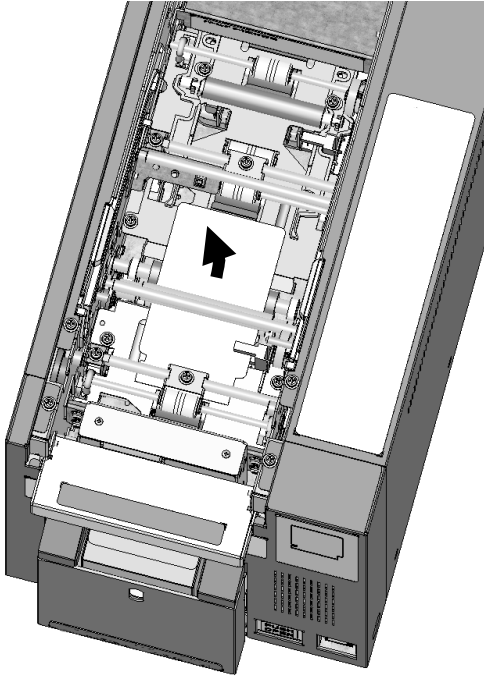

(When there is the card at the paper outlet side.)

1) Turn the knob (green) on the left side of the printer, and move the card to the front side.

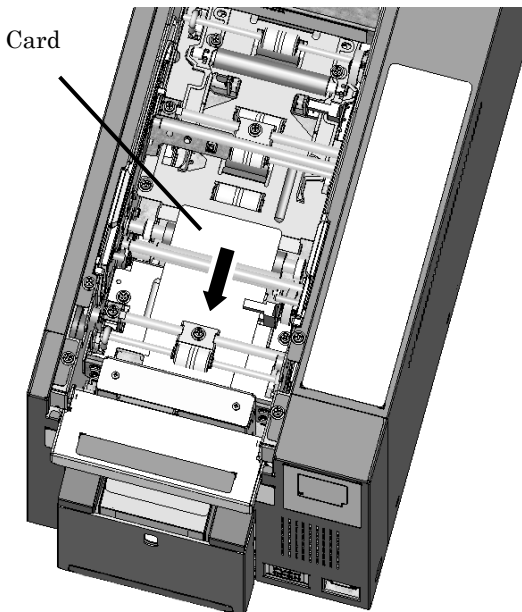

2) If the card comes out from the paper outlet, pull it up forward, and remove it.

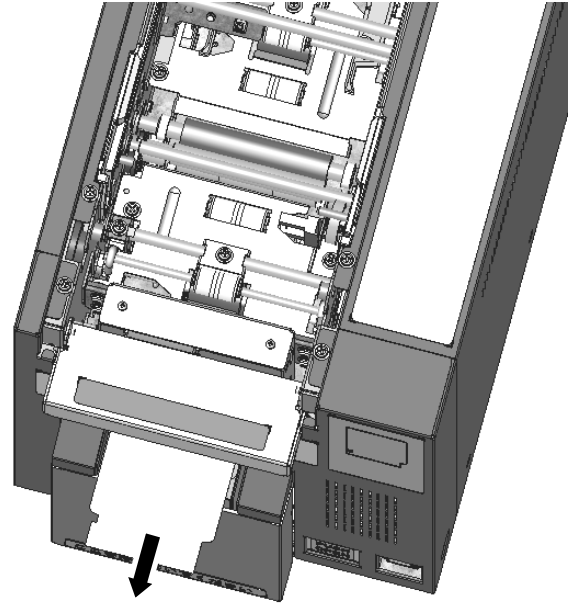

(When the card do not be seen.)

1) Turn the knob (green) on the left side of the printer to the direction of the directing arrow shown in the following figure. The card comes out shown in the following figure after turning the knob for the while (about 5 rotations), and pull it to upward and remove.

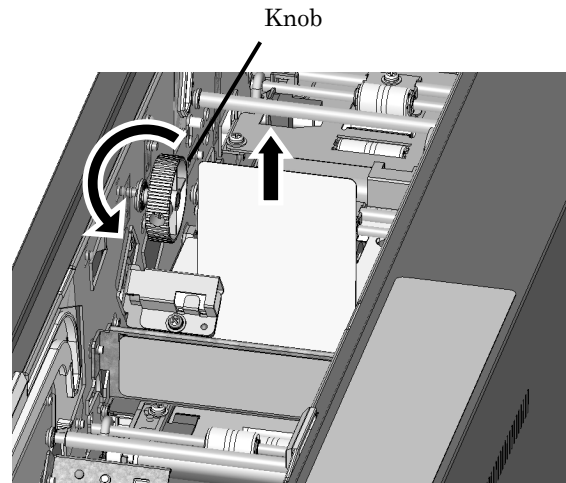

Chapter 4. Error Handling

- 2) If the card does not come out despite continue to turning knob for a while (about 5 rotations), pull up the card set unit
- 3) If tip of the card protrude little from Gate unit, move the card to the upper and pull it to upward and remove.

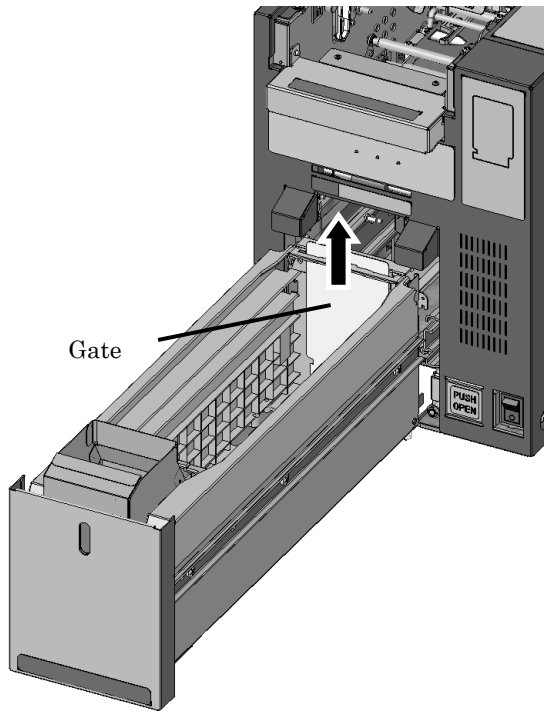

- 4) I If tip of the card does not protrude from Gate unit, close the card set unit as it is and switch the power from OFF to ON. And restart print.

(When there is the card at rear part of the printer).

- 1) Move the card by finger to the position shown in the following figure.

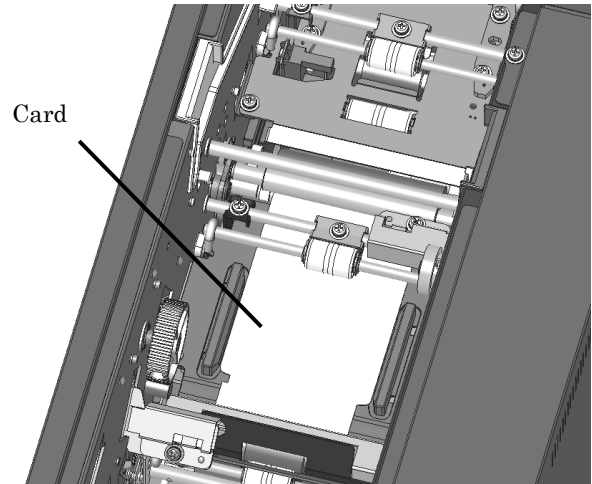

- 2) If the card move to the position shown in the following figure, pick up the top of the card and pull it up (as tilt it slightly forward) , and remove it.

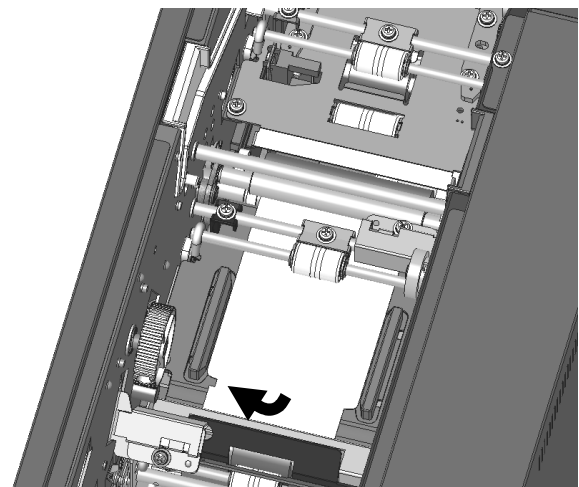

Chapter 4. Error Handling

Power Supply Interrupted during Printing

In case, power supply interrupted during the printing, Thermal Head will be kept pushing to Platen. Leaving this situation for a long time, shape of Platen can be warped. In order to avoid this situation, please follow the instruction below.

1. Turn off the power of the printer.
2. Turn on the power for 3 or more seconds after turning off the power.
3. Card Jam is displayed on the printer status lamps, open the front cover and take the necessary action according to the instruction provided in 4-2, "Card Jam".

3. Turn the ribbon on the winding side and rewind the taped section completely.

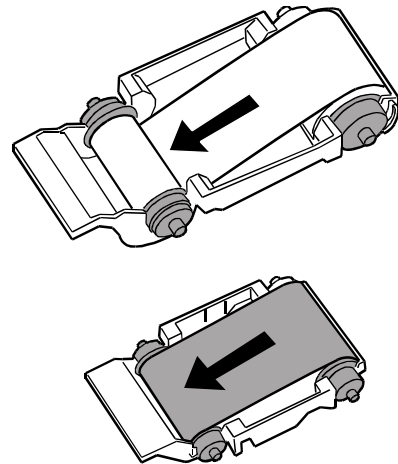

When the Ribbon is snapped

1. Remove the ink ribbon.
2. Stick the broken part of the ribbon with a tape.

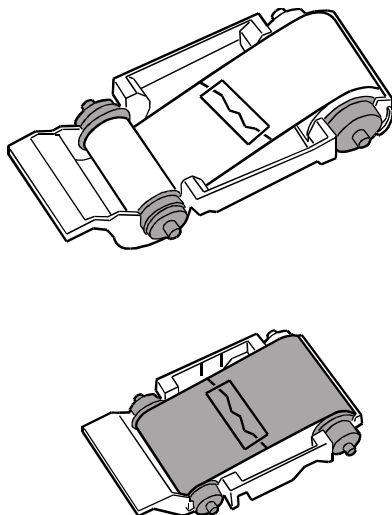

Chapter 5. In order to more comfortably use

For longer Printer usage



Caution: Printing continuous pattern of high density image in limited part may cause uneven density print. Recommend not to print those images continuously.

The consumable part of the printer (Periodic replacement recommended parts) is as follows. Check for details to after-sales service department.

- Thermal Head,
- Platen Roller
- DC MOTOR ASSY (9 type)
- Card Feeding claw

For the Customers in the U.S.A.

FCC WARNING

Changes or modifications not expressly approved by the party responsible for compliance could void the user's authority to operate the equipment.

Note: This equipment has been tested and found to comply with the limits for a Class A digital device, pursuant to part 15 of the FCC Rules. These limits are designed to provide reasonable protection against harmful interference when the equipment is operated in a commercial environment. This equipment generates, uses, and can radiate radio frequency energy and, if not installed and used in accordance with the instruction manual, may cause harmful interference to radio communications. Operation of this equipment in a residential area is likely to cause harmful interference in which case the user will be required to correct the interference at his own expense.

After-sales Service

Contact your dealers or service center for the details about after-sales service.