



RADIO TEST REPORT

Test Report No. : 11637768H-R2

Applicant : SINFONIA TECHNOLOGY CO., LTD.
Type of Equipment : Card Printer
Model No. : CHC-C320
Test regulation : FCC Part 15 Subpart C: 2016
FCC ID : ZQUCHC-C320
Test Result : Complied

1. This test report shall not be reproduced in full or partial, without the written approval of UL Japan, Inc.
2. The results in this report apply only to the sample tested.
3. This sample tested is in compliance with above regulation.
4. The test results in this report are traceable to the national or international standards.
5. This test report must not be used by the customer to claim product certification, approval, or endorsement by NVLAP, NIST, or any agency of the Federal Government.
6. This test report covers Radio technical requirements. It does not cover administrative issues such as Manual or non-Radio test related Requirements. (if applicable)
7. This report is a revised version of 11637768H-R1. 11637768H-R1 is replaced with this report.

Date of test: October 7 to 13, 2016

Representative test engineer:

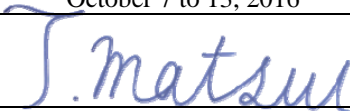

Tomoki Matsui
Engineer
Consumer Technology Division

Approved by:



Takayuki Shimada
Engineer
Consumer Technology Division

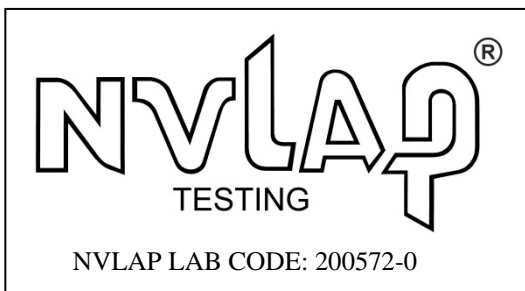

This laboratory is accredited by the NVLAP LAB CODE 200572-0, U.S.A. The tests reported herein have been performed in accordance with its terms of accreditation. *As for the range of Accreditation in NVLAP, you may refer to the WEB address, http://japan.ul.com/resources/emc_accredited/

UL Japan, Inc.

Ise EMC Lab.

4383-326 Asama-cho, Ise-shi, Mie-ken 516-0021 JAPAN

Telephone : +81 596 24 8999

Facsimile : +81 596 24 8124

13-EM-F0429

CONTENTS	PAGE
SECTION 1: Customer information	4
SECTION 2: Equipment under test (E.U.T.)	4
SECTION 3: Test specification, procedures & results	5
SECTION 4: Operation of E.U.T. during testing	8
SECTION 5: Conducted emission	10
SECTION 6: Radiated emission (Fundamental , Spurious Emission and Spectrum Mask)	11
SECTION 7: Other test	12
APPENDIX 1: Test data	13
Conducted emission	13
Fundamental emission and Spectrum Mask	17
Spurious emission	19
20dB Bandwidth and 99% Occupied Bandwidth	23
Frequency Tolerance	25
APPENDIX 2: Test instruments	26
APPENDIX 3: Photographs of test setup	27
Conducted emission	27
Radiated emission	28

SECTION 1: Customer information

Company Name : SINFONIA TECHNOLOGY CO., LTD.
Address : 100 Takegahana-cho, Ise-shi, Mie-ken, 516-8550 JAPAN
Telephone Number : +81-596-36-1286
Facsimile Number : +81-596-36-3884
Contact Person : Tsutomu Inagaki

SECTION 2: Equipment under test (E.U.T.)

2.1 Identification of E.U.T.

Type of Equipment : Card Printer
Model No. : CHC-C320
Serial No. : Refer to Section 4, Clause 4.2
Receipt Date of Sample : October 6, 2016
Country of Mass-production : Japan
Condition of EUT : Production model
Modification of EUT : No Modification by the test lab

2.2 Product Description

Radio Specification

Radio Type : Transceiver
Frequency of Operation : 13.56 MHz
Modulation : ASK
Power Supply (inner) : DC 3.3 V
Antenna type : Pattern Antenna
Clock frequency (Maximum) : 13.56 MHz
Operating Temperature : +5 deg. C - +35 deg. C

UL Japan, Inc.

Ise EMC Lab.

4383-326 Asama-cho, Ise-shi, Mie-ken 516-0021 JAPAN

Telephone : +81 596 24 8999

Facsimile : +81 596 24 8124

SECTION 3: Test specification, procedures & results

3.1 Test Specification

Test Specification : FCC Part 15 Subpart C
FCC part 15 final revised on April 6, 2016.

Title : FCC 47CFR Part15 Radio Frequency Device Subpart C Intentional Radiators
Section 15.207 Conducted limits
Section 15.225 : Operation within the band 13.110-14.010MHz

3.2 Procedures and results

Item	Test Procedure	Specification	Worst margin	Results	Remarks
Conducted emission	ANSI C63.10:2013 6 Standard test methods ----- <IC>RSS-Gen 8.8	Section 15.207 ----- <IC>RSS-Gen 8.8	QP 12.1 dB, 0.55240 MHz, N AV 8.2 dB, 0.55240 MHz, N	Complied	Conducted
Electric Field Strength of Fundamental Emission	ANSI C63.10:2013 6 Standard test methods ----- <IC> RSS-Gen 6.4, 6.12	Section 15.225(a) ----- <IC>RSS-210 B.6	77.8 dB, 13.56000 MHz, QP, 0 deg.	Complied	Radiated
Spectrum Mask	ANSI C63.10:2013 6 Standard test methods ----- <IC>RSS-Gen 6.4, 6.13	Section 15.225(b)(c) ----- <IC> RSS-210 B.6	44.8 dB, 14.01000 MHz, QP, 45 deg.	Complied	Radiated
20dB Bandwidth	ANSI C63.10:2013 6 Standard test methods ----- <IC> -	Section15.215(c) ----- <IC> -	See data	Complied	Radiated
Electric Field Strength of Spurious Emission	ANSI C63.10:2013 6 Standard test methods ----- <IC>RSS-Gen 6.4, 6.13	Section 15.209, Section 15.225 (d) ----- <IC>RSS-210 B.6	2.4 dB, 84.916 MHz, Horizontal, QP, 85.479 MHz, Horizontal, QP	Complied	Radiated
Frequency Tolerance	ANSI C63.10:2013 6 Standard test methods ----- <IC>RSS-Gen 6.11, 8.11	Section 15.225(e) ----- <IC> RSS-210 B.6	See data	Complied	Radiated

Note: UL Japan, Inc.'s EMI Work Procedures No. 13-EM-W0420 and 13-EM-W0422

FCC Part 15.31 (e)

This EUT provides stable voltage (DC 3.3 V) constantly to RF Module regardless of input voltage. Therefore, this EUT complies with the requirement.

However, the supply voltage was varied and tested at 85 % and 115 % of the nominal rated supply voltage during frequency tolerance test according to Section 15.225(e).

FCC Part 15.203 Antenna requirement

It is impossible for end users to replace the antenna, because the antenna is mounted inside of the EUT. Therefore, the equipment complies with the antenna requirement of Section 15.203.

UL Japan, Inc.

Ise EMC Lab.

4383-326 Asama-cho, Ise-shi, Mie-ken 516-0021 JAPAN

Telephone : +81 596 24 8999

Facsimile : +81 596 24 8124

3.3 Addition to standard

No.	Item	Test Procedure	Specification	Remarks	Deviation	Worst margin	Results
1	99 % Occupied Band Width	RSS-Gen 6.6	-	Radiated	N/A	N/A	N/A

Other than above, no addition, exclusion nor deviation has been made from the standard.

3.4 Uncertainty

EMI

The following uncertainties have been calculated to provide a confidence level of 95% using a coverage factor $k = 2$.

Frequency range	Conducted emission using AMN(LISN) (+/-)
0.009 – 0.15MHz	3.5 dB
0.15 – 30MHz	3.0 dB

Test distance	Radiated emission (+/-)
	9 kHz - 30 MHz
3m	3.8 dB
10m	3.7 dB

*Measurement distance

Polarity	Radiated emission (Below 1GHz)			
	(3 m*)(+/-)		(10 m*)(+/-)	
	30 – 200 MHz	200 – 1000MHz	30 – 200 MHz	200 – 1000MHz
Horizontal	5.0 dB	5.3 dB	5.0 dB	5.0 dB
Vertical	4.7 dB	5.9 dB	5.0 dB	5.1 dB

Frequency counter (+)	
Normal condition	Extreme condition
7×10^{-6}	9×10^{-6}

Conducted emission test

The data listed in this test report has enough margin, more than the site margin.

Radiated emission test (3 m)

The data listed in this report meets the limits unless the uncertainty is taken into consideration.

UL Japan, Inc.

Ise EMC Lab.

4383-326 Asama-cho, Ise-shi, Mie-ken 516-0021 JAPAN

Telephone : +81 596 24 8999

Facsimile : +81 596 24 8124

3.5 Test Location

UL Japan, Inc. Ise EMC Lab. *NVLAP Lab. code: 200572-0
4383-326 Asama-cho, Ise-shi, Mie-ken 516-0021 JAPAN
Telephone : +81 596 24 8999 Facsimile : +81 596 24 8124

	IC Registration Number	Width x Depth x Height (m)	Size of reference ground plane (m) / horizontal conducting plane	Other rooms
No.1 semi-anechoic chamber	2973C-1	19.2 x 11.2 x 7.7m	7.0 x 6.0m	No.1 Power source room
No.2 semi-anechoic chamber	2973C-2	7.5 x 5.8 x 5.2m	4.0 x 4.0m	-
No.3 semi-anechoic chamber	2973C-3	12.0 x 8.5 x 5.9m	6.8 x 5.75m	No.3 Preparation room
No.3 shielded room	-	4.0 x 6.0 x 2.7m	N/A	-
No.4 semi-anechoic chamber	2973C-4	12.0 x 8.5 x 5.9m	6.8 x 5.75m	No.4 Preparation room
No.4 shielded room	-	4.0 x 6.0 x 2.7m	N/A	-
No.5 semi-anechoic chamber	-	6.0 x 6.0 x 3.9m	6.0 x 6.0m	-
No.6 shielded room	-	4.0 x 4.5 x 2.7m	4.0 x 4.5 m	-
No.6 measurement room	-	4.75 x 5.4 x 3.0m	4.75 x 4.15 m	-
No.7 shielded room	-	4.7 x 7.5 x 2.7m	4.7 x 7.5m	-
No.8 measurement room	-	3.1 x 5.0 x 2.7m	N/A	-
No.9 measurement room	-	8.0 x 4.6 x 2.8m	2.4 x 2.4m	-
No.11 measurement room	-	6.2 x 4.7 x 3.0m	4.8 x 4.6m	-

* Size of vertical conducting plane (for Conducted Emission test): 2.0 x 2.0m for No.1, No.2, No.3, and No.4 semi-anechoic chambers and No.3 and No.4 shielded rooms.

3.6 Test set up, Test data, and Test instruments

Refer to APPENDIX.

SECTION 4: Operation of E.U.T. during testing

4.1 Operating Modes

The mode is used :

Mode	Remarks*
Transmitting mode (Tx)	The EUT Transmits and Receives at the same time and there is no receiving mode.
The EUT was operated in a manner similar to typical use during the tests.	

Test Item	Operating mode*
Electric Field Strength of Fundamental Emission	Tx Mod on, with Tag
Spectrum Mask	Tx Mod on, with Tag
20 dB Bandwidth	Tx Mod on, with Tag
99 % OccupiedBandwidth	Tx Mod on, with Tag
Electric Field Strength of Spurious Emission	Tx Mod on, with Tag
Frequency Tolerance	Tx Mod on, with Tag, Holo Antenna *1)
*1) The test was performed with Holo Antenna as representative, because there was no difference in Frequency Tolerance performance by Tag used in Holo Antenna and YMC Antenna.	

*This EUT has two modes which Tag is attached or not. The worst case was confirmed with and without Tag, as a result, the test with Tag was the worst case. Therefore the test with Tag was performed only.

Justification: The system was configured in typical fashion (as a user would normally use it) for testing.

Frequency Tolerance:

Temperature : -20 deg. C to +50 deg. C Step 10 deg. C
Voltage : Normal Voltage AC 120 V
Maximum Voltage AC 138 V, Minimum Voltage AC 102 V

UL Japan, Inc.

Ise EMC Lab.

4383-326 Asama-cho, Ise-shi, Mie-ken 516-0021 JAPAN

Telephone : +81 596 24 8999

Facsimile : +81 596 24 8124

4.2 Configuration and peripherals

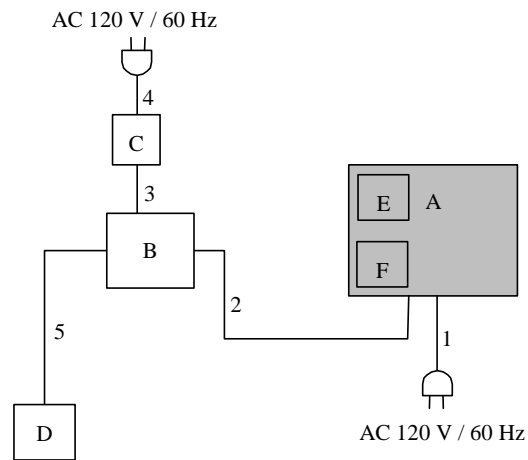

* Cabling and setup were taken into consideration and test data was taken under worse case conditions.

Description of EUT and Support equipment

No.	Item	Model number	Serial number	Manufacturer	Remarks
A	Card Printer	CHC-C320	A051	SINFONIA TECHNOLOGY CO., LTD.	EUT
B	Laptop PC	T410	R8-D76YV	Lenovo	-
C	AC Adapter	42T4418	11S42T4418Z1ZG WG24RHH1	Lenovo	-
D	Mouse	M-LY2ULBU	0X000841	ELECOM	-
E	Holo Ribbon Tag	T100C052	001	Arizon RFID Technology(Yangzhou) Co., Ltd.	EUT
F	YMC Ribbon Tag	RI-I17-112A-03	001	Texas Instruments Incorporated.	EUT

List of cables used

No.	Name	Length (m)	Shield		Remarks
			Cable	Connector	
1	AC Cable	2.0	Shielded	Shielded	-
2	USB Cable	2.0	Shielded	Shielded	-
3	DC Cable	1.7	Shielded	Shielded	-
4	AC Cable	1.0	Shielded	Shielded	-
5	Mouse Cable	1.5	Shielded	Shielded	-

UL Japan, Inc.

Ise EMC Lab.

4383-326 Asama-cho, Ise-shi, Mie-ken 516-0021 JAPAN

Telephone : +81 596 24 8999

Facsimile : +81 596 24 8124

SECTION 5: Conducted emission

Test Procedure and conditions

EUT was placed on a urethane platform of nominal size, 1.0 m by 1.5 m, raised 0.8 m above the conducting ground plane. The rear of tabletop was located 40 cm to the vertical conducting plane. The rear of EUT, including peripherals aligned and flushed with rear of tabletop. All other surfaces of tabletop were at least 80 cm from any other grounded conducting surface. EUT was located 80 cm from a Line Impedance Stabilization Network (LISN)/ Artificial mains Network (AMN) and excess AC cable was bundled in center.

1) For the tests on EUT with other peripherals (as a whole system)

I/O cables that were connected to the peripherals were bundled in center. They were folded back and forth forming a bundle 30 cm to 40 cm long and were hanged at a 40 cm height to the ground plane. All unused 50 ohm connectors of the LISN (AMN) were resistivity terminated in 50 ohm when not connected to the measuring equipment.

The AC Mains Terminal Continuous disturbance Voltage has been measured with the EUT in a Semi Anechoic Chamber. The EUT was connected to a LISN (AMN).

An overview sweep with peak detection has been performed.

The test results and limit are rounded off to one decimal place, so some differences might be observed.

Detector	: QP and CISPR AV
Measurement range	: 0.15 MHz - 30 MHz
Test data	: APPENDIX
Test result	: Pass

UL Japan, Inc.

Ise EMC Lab.

4383-326 Asama-cho, Ise-shi, Mie-ken 516-0021 JAPAN

Telephone : +81 596 24 8999

Facsimile : +81 596 24 8124

SECTION 6: Radiated emission (Fundamental , Spurious Emission and Spectrum Mask)

Test Procedure

[For below 1GHz]

EUT was placed on a urethane platform of nominal size, 1.0 m by 1.5 m, raised 0.8 m above the conducting ground plane. The Radiated Electric Field Strength has been measured in a Semi Anechoic Chamber with a ground plane.

Frequency: From 9 kHz to 30 MHz

The EUT was rotated a full revolution in order to obtain the maximum value of the electric field intensity.

The measurements were performed for vertical polarization (antenna angle: 0 deg. and 45 deg.) and horizontal polarization.

*Refer to Figure 1 about Direction of the Loop Antenna.

Frequency: From 30 MHz to 1 GHz

The measuring antenna height varied between 1 and 4 m and EUT was rotated a full revolution in order to obtain the maximum value of the electric field intensity.

The measurements were performed for both vertical and horizontal antenna polarization.

The test was made with the detector (RBW/VBW) in the following table.

When using Spectrum analyzer, the test was made with adjusting span to zero by using peak hold.

Test Antennas are used as below;

Frequency	Below 30 MHz	30 MHz to 200 MHz	200 MHz to 1 GHz
Antenna Type	Loop	Biconical	Logperiodic

Frequency	From 9 kHz to 90 kHz and From 110 kHz to 150 kHz	From 90 kHz to 110 kHz	From 150 kHz to 490 kHz	From 490 kHz to 30 MHz	From 30 MHz to 1 GHz
Instrument used	Test Receiver				
Detector	PK / AV	QP	PK / AV	QP	QP
IF Bandwidth	200 Hz	200 Hz	9 kHz	9 kHz	120 kHz
Test Distance	3 m *1)	3 m *1)	3 m *1)	3 m *2)	3 m

*1) Distance Factor: $40 \times \log(3 \text{ m} / 300 \text{ m}) = -80 \text{ dB}$

*2) Distance Factor: $40 \times \log(3 \text{ m} / 30 \text{ m}) = -40 \text{ dB}$

Although these tests were performed other than open field test site, adequate comparison measurements were confirmed against 30 m open field test site. Therefore sufficient tests were made to demonstrate that the alternative site produces results that correlate with the ones of tests made in an open field based on KDB 937606.

These tests were performed in semi anechoic chamber. Therefore the measured level of emissions may be higher than if measurements were made without a ground plane.

However test results were confirmed to pass against standard limit.

This EUT has two modes which Tag is attached or not. The worst case was confirmed with and without Tag, as a result, the test with Tag was the worst case. Therefore the test with Tag was performed only.

The test was made on EUT at the normal use position.

The test results and limit are rounded off to one decimal place, so some differences might be observed.

Measurement range : 9 kHz - 1 GHz
Test data : APPENDIX 1
Test result : Pass

UL Japan, Inc.

Ise EMC Lab.

4383-326 Asama-cho, Ise-shi, Mie-ken 516-0021 JAPAN

Telephone : +81 596 24 8999

Facsimile : +81 596 24 8124

SECTION 7: Other test

Test	Span	RBW	VBW	Sweep	Detector	Trace	Instrument used
20 dB Bandwidth	300 kHz	3 kHz	10 kHz	Auto	Peak	Max Hold	Spectrum Analyzer
99 % Occupied Bandwidth	Enough width to display emission skirts	1 to 5 % of OBW	Three times of RBW	Auto	Peak *1)	Max Hold *1)	Spectrum Analyzer
Frequency Tolerance	-	-	-	-	-	-	Frequency counter

*1) The measurement was performed with Peak detector, Max Hold since the duty cycle was not 100 %.
Peak hold was applied as Worst-case measurement.

Test data : APPENDIX
Test result : Pass

Figure 1: Direction of the Loop Antenna

Side View (Vertical)



Top View (Horizontal)

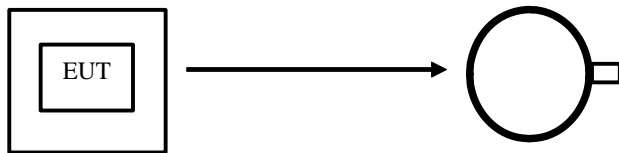

Antenna was not rotated.

Top View (Vertical)

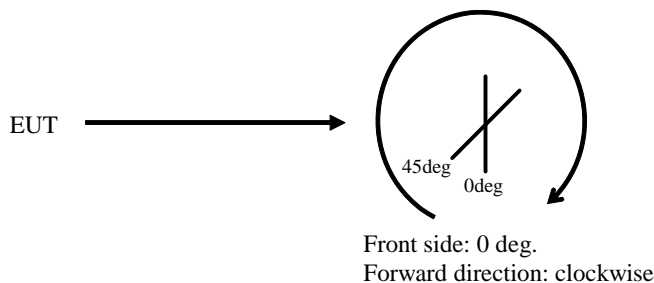

APPENDIX 1: Test data

Conducted emission

DATA OF CONDUCTED EMISSION TEST

UL Japan, Inc. Ise EMC Lab. No.4 Semi Anechoic Chamber
Date : 2016/10/12

Report No. : 11637768H
Temp./Humi. : 23deg. C / 57% RH
Engineer : Tomoki Matsui

Mode / Remarks : Tx 13.56MHz HoloRibbon mode

LIMIT : FCC15.107(b) QP ClassA
FCC15.107(b) AV ClassA

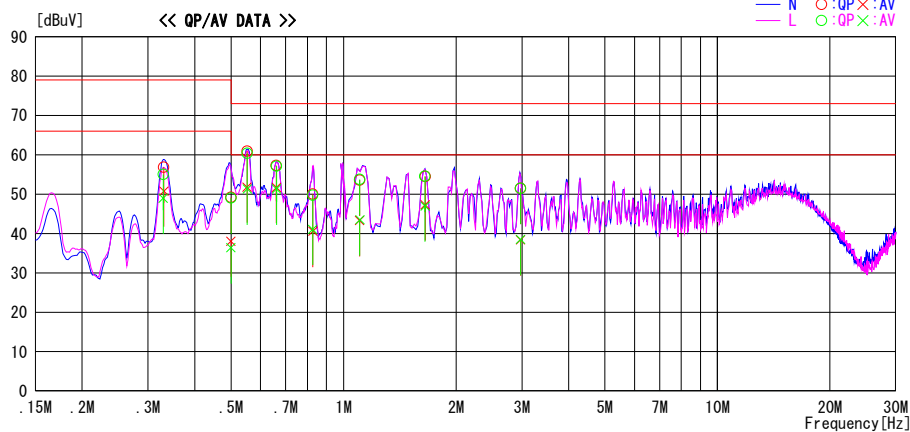

Frequency [MHz]	Reading Level		Corr. Factor [dB]	Results		Limit		Margin		Phase	Comment
	QP [dBuV]	AV [dBuV]		QP [dBuV]	AV [dBuV]	QP [dBuV]	AV [dBuV]	QP [dB]	AV [dB]		
0.32958	41.5	35.5	13.5	55.0	49.0	79.0	66.0	24.0	17.0	L	
0.33078	43.3	37.3	13.5	56.8	50.8	79.0	66.0	22.2	15.2	N	
0.50001	35.5	22.9	13.5	49.0	36.4	73.0	60.0	24.0	23.6	L	
0.50001	35.7	24.6	13.5	49.2	38.1	73.0	60.0	23.8	21.9	N	
0.55240	47.4	38.3	13.5	60.9	51.8	73.0	60.0	12.1	8.2	N	
0.55259	46.9	37.8	13.5	60.4	51.3	73.0	60.0	12.6	8.7	L	
0.66120	43.8	38.2	13.5	57.3	51.7	73.0	60.0	15.7	8.3	N	
0.66160	43.6	37.8	13.5	57.1	51.3	73.0	60.0	15.9	8.7	L	
0.82739	36.1	27.5	13.6	49.7	41.1	73.0	60.0	23.3	18.9	L	
0.82822	36.4	27.0	13.6	50.0	40.6	73.0	60.0	23.0	19.4	N	
1.10399	40.0	29.7	13.6	53.6	43.3	73.0	60.0	19.4	16.7	N	
1.10503	40.1	29.9	13.6	53.7	43.5	73.0	60.0	19.3	16.5	L	
1.65252	41.0	33.4	13.6	54.6	47.0	73.0	60.0	18.4	13.0	L	
1.65379	40.9	33.7	13.6	54.5	47.3	73.0	60.0	18.5	12.7	N	
2.97398	37.7	24.6	13.8	51.5	38.4	73.0	60.0	21.5	21.6	N	
2.97398	37.7	24.7	13.8	51.5	38.5	73.0	60.0	21.5	21.5	L	

CHART : WITH FACTOR. Peak hold data. CALCULATION : RESULT = READING + C.F (LISN + ATTEN + CABLE)
Except for the above table : adequate margin data below the limits.

*For a limit of Conducted emission, the Section 15.107(b) Class A for the EMC noise and the Section 15.207 for 13.56 MHz were applied since this product was corresponded to Class A device based on the FCC15 subpart B. In addition, there are no differences in spurious emission of radio operation and EMC operation.

UL Japan, Inc.
Ise EMC Lab.

4383-326 Asama-cho, Ise-shi, Mie-ken 516-0021 JAPAN
Telephone : +81 596 24 8999
Facsimile : +81 596 24 8124

Conducted emission

DATA OF CONDUCTED EMISSION TEST

UL Japan, Inc. Ise EMC Lab. No.4 Semi Anechoic Chamber
Date : 2016/10/08

Report No. : 11637768H
 Temp./Humi. : 25deg. C / 56% RH
 Engineer : Satofumi Matsuyama

Mode / Remarks : Tx 13.56MHz HoloRibbon mode

LIMIT : FCC15.207 QP
 FCC15.207 AV

— N ○:QP×:AV
 — L ○:QP×:AV
 — L2 ○:QP×:AV
 — L3 ○:QP×:AV

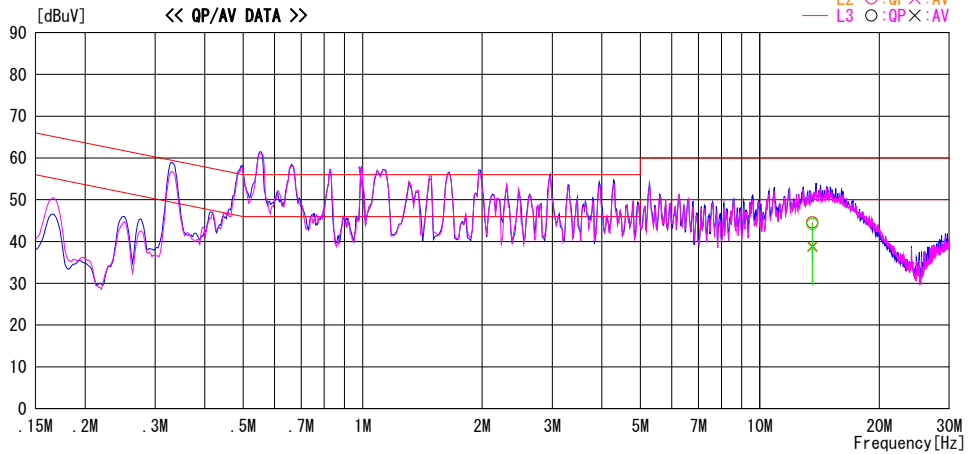

Frequency [MHz]	Reading Level		Corr. Factor [dB]	Results		Limit		Margin		Phase	Comment
	QP [dBuV]	AV [dBuV]		QP [dBuV]	AV [dBuV]	QP [dBuV]	AV [dBuV]	QP [dB]	AV [dB]		
13.56000	30.1	24.4	14.5	44.6	38.9	60.0	50.0	15.4	11.1	N	
13.56000	29.7	24.1	14.5	44.2	38.6	60.0	50.0	15.8	11.4	L	

CHART : WITH FACTOR, Peak hold data. CALCULATION : RESULT = READING + C. F (LISN + ATTEN + CABLE)
 Except for the above table : adequate margin data below the limits.

Conducted emission

DATA OF CONDUCTED EMISSION TEST

UL Japan, Inc. Ise EMC Lab. No.4 Semi Anechoic Chamber
Date : 2016/10/12

Report No. : 11637768H
Temp./Humi. : 23deg. C / 57% RH
Engineer : Tomoki Matsui

Mode / Remarks : Tx 13.56MHz YMC Ribbon mode

LIMIT : FCC15.107(b) QP ClassA
FCC15.107(b) AV ClassA

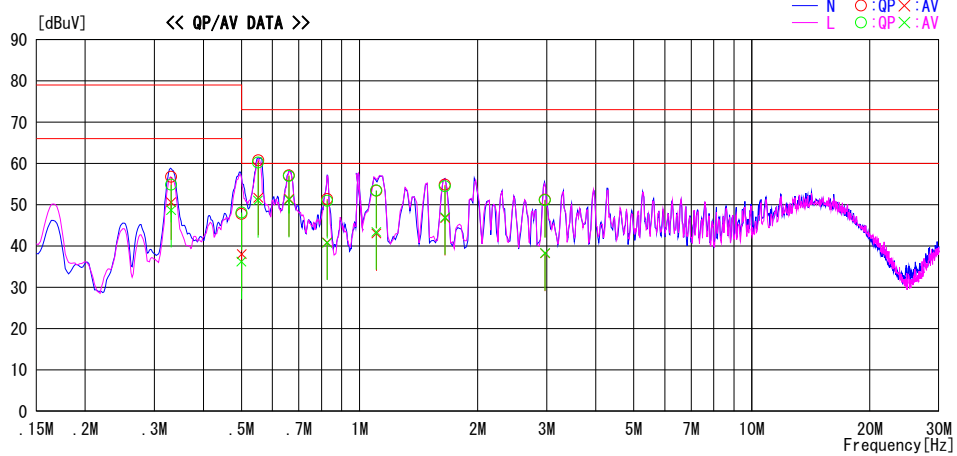

Frequency [MHz]	Reading Level		Corr. [dB]	Results		Limit		Margin		Phase	Comment
	QP [dBuV]	AV [dBuV]		QP [dBuV]	AV [dBuV]	QP [dBuV]	AV [dBuV]	QP [dB]	AV [dB]		
0.33080	41.3	35.2	13.5	54.8	48.7	79.0	66.0	24.2	17.3	L	
0.33080	43.2	37.1	13.5	56.7	50.6	79.0	66.0	22.3	15.4	N	
0.50020	34.6	22.7	13.5	48.1	36.2	73.0	60.0	24.9	23.8	L	
0.50058	34.2	24.6	13.5	47.7	38.1	73.0	60.0	25.3	21.9	N	
0.55120	46.7	37.6	13.5	60.2	51.1	73.0	60.0	12.8	8.9	L	
0.55239	47.2	38.2	13.5	60.7	51.7	73.0	60.0	12.3	8.3	N	
0.66110	43.6	37.9	13.5	57.1	51.4	73.0	60.0	15.9	8.6	N	
0.66120	43.4	37.7	13.5	56.9	51.2	73.0	60.0	16.1	8.8	L	
0.82679	37.3	27.2	13.6	50.9	40.8	73.0	60.0	22.1	19.2	L	
0.82719	37.8	27.3	13.6	51.4	40.9	73.0	60.0	21.6	19.1	N	
1.10359	39.9	29.8	13.6	53.5	43.4	73.0	60.0	19.5	16.6	L	
1.10480	39.8	29.5	13.6	53.4	43.1	73.0	60.0	19.6	16.9	N	
1.65230	40.9	33.4	13.6	54.5	47.0	73.0	60.0	18.5	13.0	L	
1.65180	41.2	33.2	13.6	54.8	46.8	73.0	60.0	18.2	13.2	N	
2.97157	37.4	24.4	13.8	51.2	38.2	73.0	60.0	21.8	21.8	N	
2.97197	37.3	24.5	13.8	51.1	38.3	73.0	60.0	21.9	21.7	L	

CHART : WITH FACTOR, Peak hold data. CALCULATION : RESULT = READING + C.F (LISN + ATTEN + CABLE)
Except for the above table : adequate margin data below the limits.

*For a limit of Conducted emission, the Section 15.107(b) Class A for the EMC noise and the Section 15.207 for 13.56 MHz were applied since this product was corresponded to Class A device based on the FCC15 subpart B. In addition, there are no differences in spurious emission of radio operation and EMC operation.

UL Japan, Inc.
Ise EMC Lab.

4383-326 Asama-cho, Ise-shi, Mie-ken 516-0021 JAPAN
Telephone : +81 596 24 8999
Facsimile : +81 596 24 8124

Conducted emission

DATA OF CONDUCTED EMISSION TEST

UL Japan, Inc. Ise EMC Lab. No.4 Semi Anechoic Chamber
Date : 2016/10/08

Report No. : 11637768H
 Temp./Humi. : 25deg. C / 56% RH
 Engineer : Satofumi Matsuyama

Mode / Remarks : Tx 13.56MHz YMCribbon mode

LIMIT : FCC15.207 QP
 FCC15.207 AV

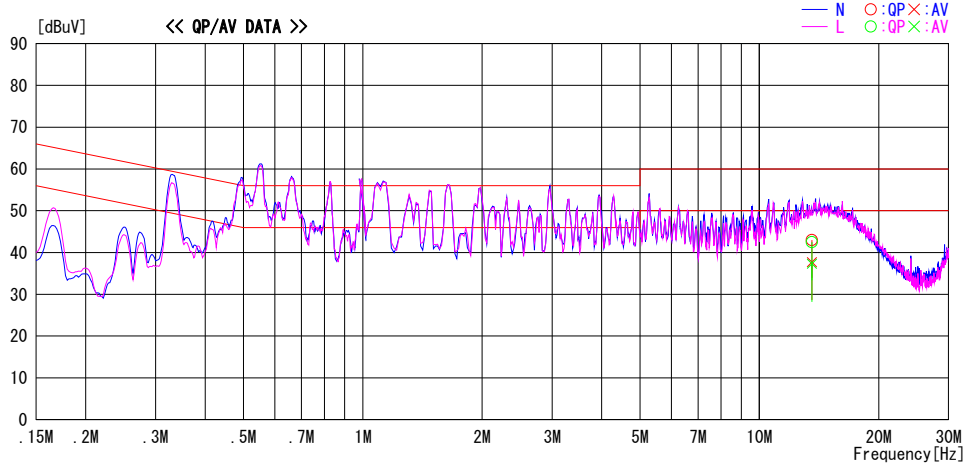

Frequency [MHz]	Reading Level		Corr. Factor [dB]	Results		Limit		Margin		Phase	Comment
	QP [dBuV]	AV [dBuV]		QP [dBuV]	AV [dBuV]	QP [dBuV]	AV [dBuV]	QP [dB]	AV [dB]		
13.56000	28.5	23.2	14.5	43.0	37.7	60.0	50.0	17.0	12.3	N	
13.56000	28.0	22.8	14.5	42.5	37.3	60.0	50.0	17.5	12.7	L	

CHART : WITH FACTOR. Peak hold data. CALCULATION : RESULT = READING + C. F (LISN + ATTEN + CABLE)
 Except for the above table : adequate margin data below the limits.

Fundamental emission and Spectrum Mask

DATA OF RADIATED EMISSION TEST

UL Japan, Inc. Ise EMC Lab. No. 4 Semi Anechoic Chamber
Date : 2016/10/07

Report No. : 11637768H
Temp. / Humi. : 25deg. C / 56% RH
Engineer : Satofumi Matsuyama

Mode / Remarks : Tx 13.56MHz HoloRibbon mode

LIMIT : FCC15_225_PKQP, 9-90kHz:PK, 110-490kHz:PK, other:QP
FCC15_225_AVQP, 9-90kHz:AV, 110-490kHz:AV, other:QP

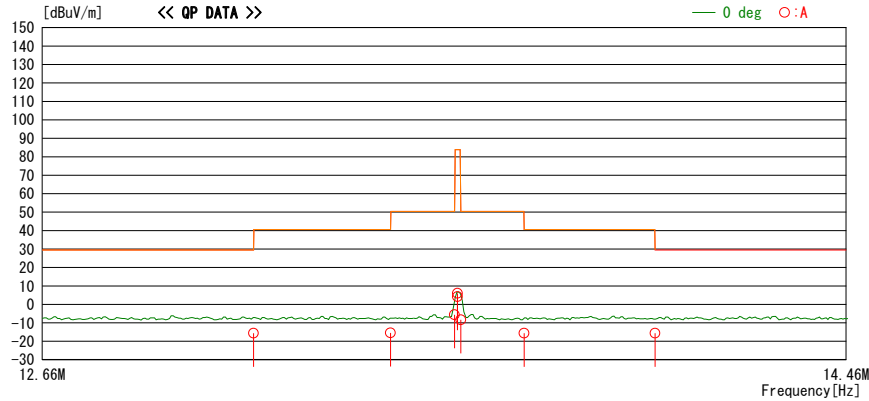

Freq. [MHz]	Reading [dBuV]	DET	Ant. Fac [dB/m]	Loss [dB]	Gain [dB]	Result [dBuV/m]	Limit [dBuV/m]	Margin [dB]	Antenna [deg]	Table	Comment
										[deg]	
13.11000	29.9	QP	19.6	-33.1	32.1	-15.7	29.5	45.2	0	A	182
13.41000	30.0	QP	19.6	-33.0	32.1	-15.5	40.5	56.0	0	A	182
13.55300	39.8	QP	19.6	-33.0	32.1	-5.7	50.4	56.1	0	A	182
13.56000	51.6	QP	19.6	-33.0	32.1	6.1	83.9	77.8	0	A	182
13.56000	49.9	QP	19.4	-33.0	32.1	4.2	83.9	79.7	0	A	182
13.56700	37.2	QP	19.6	-33.0	32.1	-8.3	50.4	58.7	0	A	182
13.71000	29.9	QP	19.6	-33.0	32.1	-15.6	40.5	56.1	0	A	182
14.01000	29.8	QP	19.6	-33.0	32.1	-15.7	29.5	45.2	0	A	182

CHART: WITH FACTOR, ANT TYPE: LOOP Except for the data below: adequate margin data below the limits.
CALCULATION : RESULT = READING + ANT FACTOR + LOSS (CABLE + ATTEN.) - GAIN (AMP)

Result of the fundamental emission at 3 m without Distance factor

Ant Deg [deg]	Frequency [MHz]	Detector	Reading [dBuV]	Ant Factor [dB/m]	Loss [dB]	Gain [dB]	Duty Factor [dB]	Result [dBuV/m]	Limit [dBuV/m]	Margin [dB]	Remark
0	13.56000	QP	51.6	19.6	6.9	32.1	-	46.0	-	-	Fundamental

Result = Reading + Ant Factor + Loss (Cable+Attenuator+Filter) - Gain(Amplifier)

* Gain 0.0 dB shows that the pre amplifier was not used to avoid the influence of carrier power.
The pre amplifier used for carrier frequency measurement was not saturated.

UL Japan, Inc.
Ise EMC Lab.

4383-326 Asama-cho, Ise-shi, Mie-ken 516-0021 JAPAN
Telephone : +81 596 24 8999
Facsimile : +81 596 24 8124

Fundamental emission and Spectrum Mask

DATA OF RADIATED EMISSION TEST

UL Japan, Inc. Ise EMC Lab. No.4 Semi Anechoic Chamber
Date : 2016/10/07

Report No. : 11637768H
Temp./ Humi. : 25deg. C / 56% RH
Engineer : Satofumi Matsuyama

Mode / Remarks : Tx 13.56MHz YMC Ribbon mode

LIMIT : FCC15_225_PKQP, 9-90kHz:PK, 110-490kHz:PK, other:QP
FCC15_225_AVQP, 9-90kHz:AV, 110-490kHz:AV, other:QP

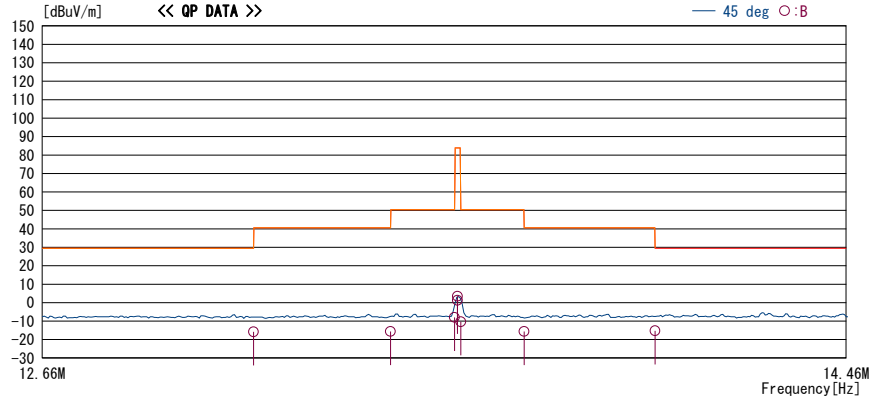

Freq.	Reading	DET	Ant. Fac	Loss	Gain	Result	Limit	Margin	Antenna	Table	Comment
[MHz]	[dBuV]		[dB/m]	[dB]	[dB]	[dBuV/m]	[dBuV/m]	[dB]	[deg]	[deg]	
13.11000	29.8	QP	19.6	-33.1	32.1	-15.8	29.5	45.3	45	B	151
13.41000	29.9	QP	19.6	-33.0	32.1	-15.6	40.5	56.1	45	B	151
13.55300	37.5	QP	19.6	-33.0	32.1	-8.0	50.4	58.4	45	B	151
13.56000	48.9	QP	19.6	-33.0	32.1	3.4	83.9	80.5	45	B	151
13.56000	47.0	QP	19.4	-33.0	32.1	1.3	83.9	82.6	45	B	151 without Tag
13.56700	35.2	QP	19.6	-33.0	32.1	-10.3	50.4	60.7	45	B	151
13.71000	29.8	QP	19.6	-33.0	32.1	-15.7	40.5	56.2	45	B	151
14.01000	30.2	QP	19.6	-33.0	32.1	-15.3	29.5	44.8	45	B	151

CHART: WITH FACTOR, ANT TYPE: LOOP Except for the data below: adequate margin data below the limits.
CALCULATION: RESULT = READING + ANT FACTOR + LOSS(CABLE + ATTEN.) - GAIN(AMP)

Result of the fundamental emission at 3 m without Distance factor

QP

Ant Deg [deg]	Frequency	Detector	Reading	Ant Factor	Loss	Gain	Duty Factor	Result	Limit	Margin	Remark
	[MHz]		[dBuV]	[dB/m]	[dB]	[dB]	[dB]	[dBuV/m]	[dBuV/m]	[dB]	
0	13.56000	QP	48.9	19.6	6.9	32.1	-	43.3	-	-	Fundamental

Result = Reading + Ant Factor + Loss (Cable+Attenuator+Filter) - Gain(Amplifier)

* Gain 0.0 dB shows that the pre amplifier was not used to avoid the influence of carrier power.
The pre amplifier used for carrier frequency measurement was not saturated.

UL Japan, Inc.
Ise EMC Lab.

4383-326 Asama-cho, Ise-shi, Mie-ken 516-0021 JAPAN
Telephone : +81 596 24 8999
Facsimile : +81 596 24 8124

Spurious emission

DATA OF RADIATED EMISSION TEST

UL Japan, Inc. Ise EMC Lab. No.4 Semi Anechoic Chamber
Date : 2016/10/07

Report No. : 11637768H
Temp. / Humi. : 25deg. C / 56% RH
Engineer : Satofumi Matsuyama

Mode / Remarks : Tx 13.56MHz HoloRibbon mode

LIMIT : FCC15_225_PKQP, 9-90kHz:PK, 110-490kHz:PK, other:QP
FCC15_225_AVQP, 9-90kHz:AV, 110-490kHz:AV, other:QP

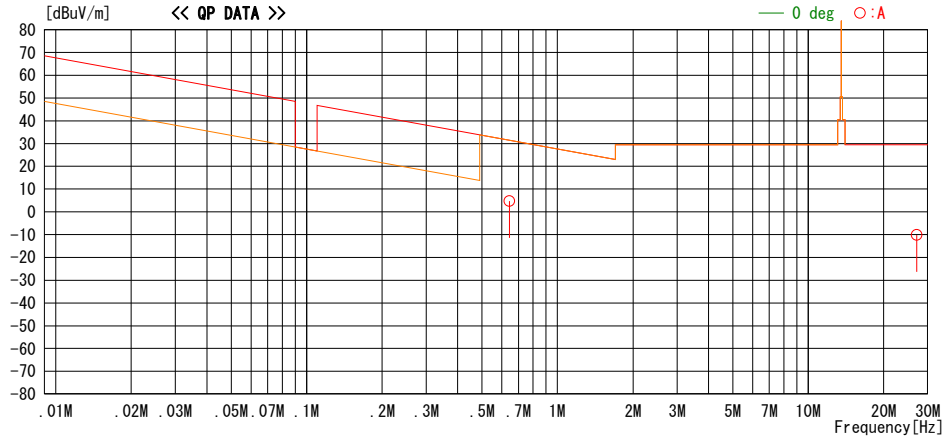

Freq.	Reading	DET	Ant. Fac	Loss	Gain	Result	Limit	Margin	Antenna	Table	Comment
[MHz]	[dBuV]		[dB/m]	[dB]	[dB]	[dBuV/m]	[dBuV/m]	[dB]	[deg]	[deg]	
0.64299	51.3	QP	19.2	-33.7	32.1	4.7	31.4	26.7	0	A	359
27.12000	34.5	QP	20.2	-32.8	32.1	-10.2	29.5	39.7	0	A	269

CHART: WITH FACTOR , ANT TYPE: LOOP Except for the data below : adequate margin data below the limits.
CALCULATION : RESULT = READING + ANT FACTOR + LOSS (CABLE + ATTEN.) - GAIN (AMP)

Spurious emission

DATA OF RADIATED EMISSION TEST

UL Japan, Inc. Ise EMC Lab. No.4 Semi Anechoic Chamber
Date : 2016/10/07

Report No. : 11637768H
Temp. / Humi. : 25deg. C / 56% RH
Engineer : Satofumi Matsuyama

Mode / Remarks : Tx 13.56MHz YMC Ribbon mode

LIMIT : FCC15_225_PKQP, 9-90kHz:PK, 110-490kHz:PK, other:QP
FCC15_225_AVQP, 9-90kHz:AV, 110-490kHz:AV, other:QP

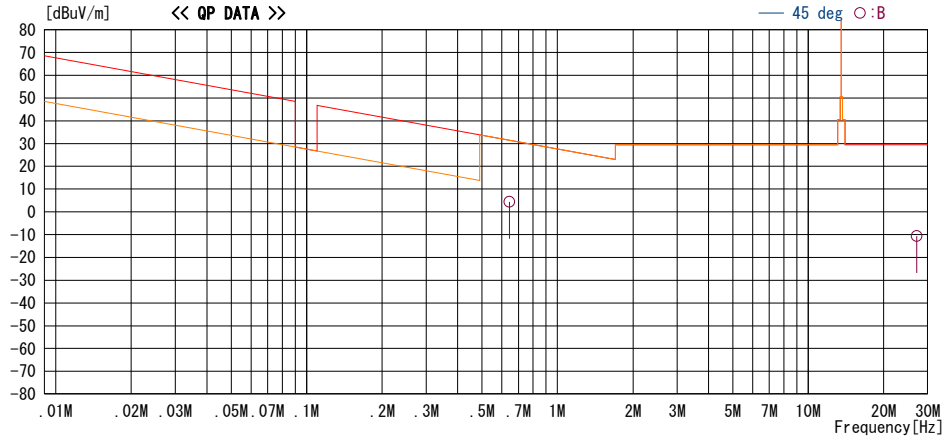

Freq.	Reading	DET	Ant. Fac	Loss	Gain	Result	Limit	Margin	Antenna	Table	Comment
[MHz]	[dBuV]		[dB/m]	[dB]	[dB]	[dBuV/m]	[dBuV/m]	[dB]	[deg]	[deg]	
0.64299	51.0	QP	19.2	-33.7	32.1	4.4	31.4	27.0	45	B	222
27.12000	34.0	QP	20.2	-32.8	32.1	-10.7	29.5	40.2	45	B	344

CHART: WITH FACTOR, ANT TYPE: LOOP Except for the data below : adequate margin data below the limits.
CALCULATION : RESULT = READING + ANT FACTOR + LOSS (CABLE + ATTEN.) - GAIN (AMP)

Spurious emission

DATA OF RADIATED EMISSION TEST

UL Japan, Inc. Head Office EMC Lab. No. 4 Semi Anechoic Chamber
Date : 2016/10/07

Report No. : 11637768H
Temp./Humi. : 24 deg. C / 52 % RH
Engineer : Takumi Shimada

Mode / Remarks : Tx 13.56MHz HoloRibbon mode

LIMIT : FCC15.209 3m, below 1GHz:QP, above 1GHz:PK
All other spurious emissions were less than 20dB for the limit.

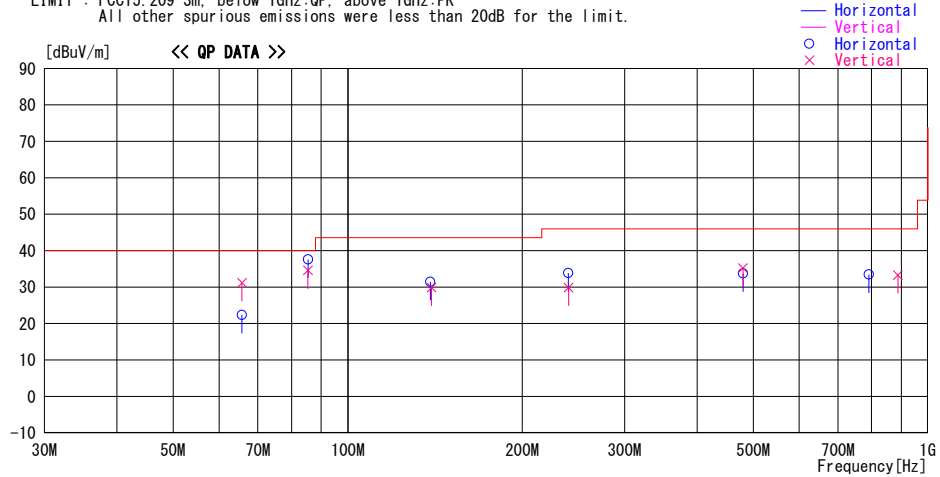

Frequency [MHz]	Reading [dBuV]	DET	Antenna		Level [dBuV/m]	Angle [Deg]	Height [cm]	Polar.	Limit [dBuV/m]	Margin [dB]	Comment
			Factor [dB/m]	Loss& Gain [dB]							
65.758	39.9	QP	6.7	-24.3	22.3	259	237	Hori.	40.0	17.7	
65.745	48.8	QP	6.7	-24.3	31.2	216	100	Vert.	40.0	8.8	
85.479	54.0	QP	7.6	-24.0	37.6	171	231	Hori.	40.0	2.4	
85.401	51.1	QP	7.5	-24.0	34.6	145	100	Vert.	40.0	5.4	
138.801	40.4	QP	14.4	-23.4	31.4	198	219	Hori.	43.5	12.1	
139.418	38.9	QP	14.4	-23.4	29.9	171	100	Vert.	43.5	13.6	
239.980	44.3	QP	12.1	-22.5	33.9	306	118	Hori.	46.0	12.1	
240.352	40.3	QP	12.1	-22.5	29.9	218	147	Vert.	46.0	16.1	
480.000	39.2	QP	17.2	-21.2	35.2	249	100	Vert.	46.0	10.8	
480.000	37.7	QP	17.2	-21.2	33.7	193	100	Hori.	46.0	12.3	
791.998	31.9	QP	20.7	-19.2	33.4	159	100	Hori.	46.0	12.6	
888.018	29.8	QP	21.7	-18.2	33.3	228	100	Vert.	46.0	12.7	

CHART: WITH FACTOR ANT TYPE: -30MHz: LOOP, 30-300MHz: BICONICAL, 300MHz-1000MHz: LOGPERIODIC, 1000MHz-: HORN
CALCULATION: RESULT = READING + ANT FACTOR + LOSS & GAIN (CABLE + ATTEN. - GAIN(AMP))

Spurious emission

DATA OF RADIATED EMISSION TEST

UL Japan, Inc. Head Office EMC Lab. No.4 Semi Anechoic Chamber
Date : 2016/10/07

Report No. : 11637768H
Temp./Humi. : 24 deg. C / 52 % RH
Engineer : Takumi Shimada

Mode / Remarks : Tx 13.56MHz YMCribbon mode

LIMIT : FCC15.209 3m, below 1GHz:QP, above 1GHz:PK
All other spurious emissions were less than 20dB for the limit.

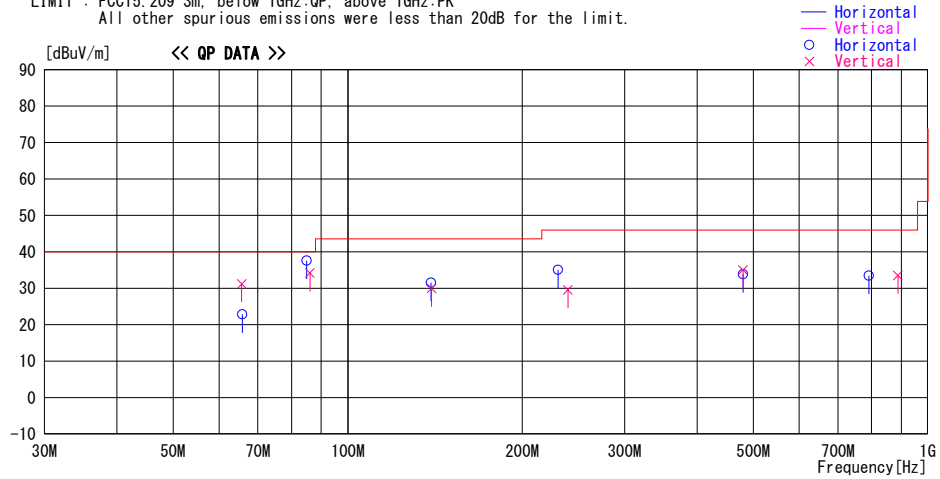

Frequency [MHz]	Reading [dBuV]	DET	Antenna		Level [dBuV/m]	Angle [Deg]	Height [cm]	Polar.	Limit [dBuV/m]	Margin [dB]	Comment
			Factor [dB/m]	Loss& Gain [dB]							
65.772	40.4	QP	6.7	-24.3	22.8	256	227	Hori.	40.0	17.2	
65.632	48.8	QP	6.7	-24.3	31.2	219	100	Vert.	40.0	8.8	
84.916	54.1	QP	7.5	-24.0	37.6	169	229	Hori.	40.0	2.4	
86.078	50.5	QP	7.7	-24.0	34.2	142	100	Vert.	40.0	5.8	
139.139	40.5	QP	14.4	-23.4	31.5	194	224	Hori.	43.5	12.0	
139.418	39.0	QP	14.4	-23.4	30.0	181	100	Vert.	43.5	13.5	
239.530	45.7	QP	11.9	-22.5	35.1	313	123	Hori.	46.0	10.9	
239.590	40.0	QP	12.1	-22.5	29.6	216	162	Vert.	46.0	16.4	
480.000	39.0	QP	17.2	-21.2	35.0	251	100	Vert.	46.0	11.0	
480.000	37.9	QP	17.2	-21.2	33.9	191	100	Hori.	46.0	12.1	
791.990	31.9	QP	20.7	-19.2	33.4	163	100	Hori.	46.0	12.6	
887.998	30.0	QP	21.7	-18.2	33.5	231	100	Vert.	46.0	12.5	

CHART:WITH FACTOR ANT TYPE: -30MHz:LOOP, 30-300MHz:BICONICAL, 300MHz-1000MHz:LOGPERIODIC, 1000MHz-:HORN
CALCULATION:RESULT = READING + ANT FACTOR + LOSS & GAIN (CABLE + ATTEN. - GAIN(AMP))

20dB Bandwidth and 99% Occupied Bandwidth

Test place	Ise EMC Lab. No.4 Semi Anechoic Chamber
Report No.	11637768H
Date	10/7/2016
Temperature/ Humidity	25 deg. C / 56 % RH
Engineer	Satofumi Matsuyama
Mode	Tx 13.56MHz Holo Ribbon mode

FREQ [MHz]	20dB Bandwidth [kHz]	99% Occupied Bandwidth [kHz]
13.56	14.42	120.40

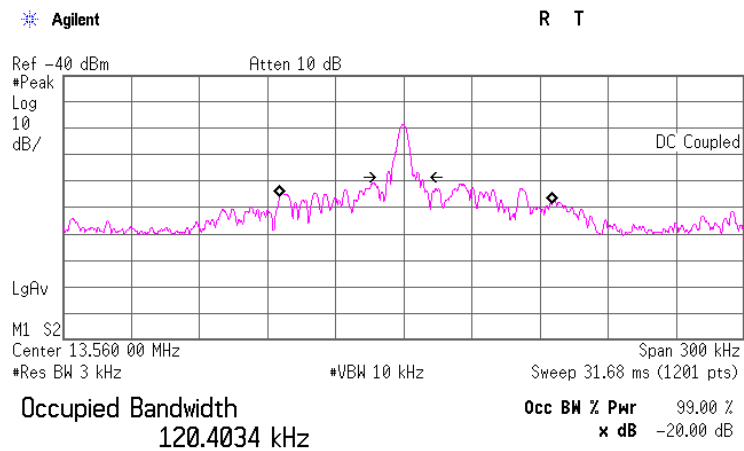

Transmit Freq Error 5.496 kHz
x dB Bandwidth 14.424 kHz

20dB Bandwidth and 99% Occupied Bandwidth

Test place	Ise EMC Lab. No.4 Semi Anechoic Chamber
Report No.	11637768H
Date	10/7/2016
Temperature/ Humidity	25 deg. C / 56 % RH
Engineer	Satofumi Matsuyama
Mode	Tx 13.56MHz YMCR Ribbon mode

FREQ [MHz]	20dB Bandwidth [kHz]	99% Occupied Bandwidth [kHz]
13.56	53.72	133.16

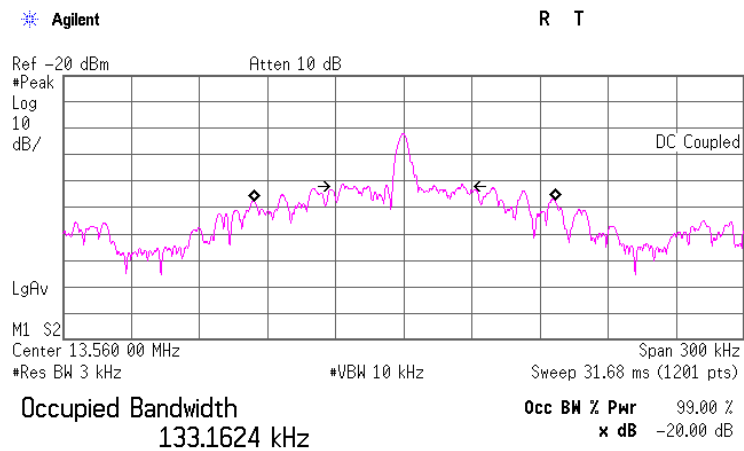

Transmit Freq Error 300.115 Hz
x dB Bandwidth 53.717 kHz

Frequency Tolerance

Test place	Ise EMC Lab. No.9 measurement room
Report No.	11637768H
Date	10/13/2016
Temperature/ Humidity	24 deg. C / 51 % RH
Engineer	Tomoki Matsui
Mode	Tx 13.56 MHz Holo Ribbon mode

Test condition		Tested timing	Measured frequency [MHz]	Frequency error [MHz]	Result		Limit [+/- %]
Temp. [deg. C]	Voltage [V]				[%]	[ppm]	
50	120	Power on	13.559581	-0.000419	-0.00309	-30.9	0.01
		+ 2 min.	13.559579	-0.000421	-0.00310	-31.0	0.01
		+ 5 min.	13.559578	-0.000422	-0.00311	-31.1	0.01
		+ 10 min.	13.559578	-0.000422	-0.00311	-31.1	0.01
40	120	Power on	13.559579	-0.000421	-0.00310	-31.0	0.01
		+ 2 min.	13.559578	-0.000422	-0.00311	-31.1	0.01
		+ 5 min.	13.559577	-0.000423	-0.00312	-31.2	0.01
		+ 10 min.	13.559577	-0.000423	-0.00312	-31.2	0.01
30	120	Power on	13.559580	-0.000420	-0.00310	-31.0	0.01
		+ 2 min.	13.559581	-0.000419	-0.00309	-30.9	0.01
		+ 5 min.	13.559580	-0.000420	-0.00310	-31.0	0.01
		+ 10 min.	13.559580	-0.000420	-0.00310	-31.0	0.01
20	120	Power on	13.559600	-0.000400	-0.00295	-29.5	0.01
		+ 2 min.	13.559600	-0.000400	-0.00295	-29.5	0.01
		+ 5 min.	13.559598	-0.000402	-0.00296	-29.6	0.01
		+ 10 min.	13.559596	-0.000404	-0.00298	-29.8	0.01
20	102 (120V -15%)	Power on	13.559596	-0.000404	-0.00298	-29.8	0.01
		+ 2 min.	13.559596	-0.000404	-0.00298	-29.8	0.01
		+ 5 min.	13.559596	-0.000404	-0.00298	-29.8	0.01
		+ 10 min.	13.559595	-0.000405	-0.00299	-29.9	0.01
20	138 (120V +15%)	Power on	13.559596	-0.000404	-0.00298	-29.8	0.01
		+ 2 min.	13.559596	-0.000404	-0.00298	-29.8	0.01
		+ 5 min.	13.559596	-0.000404	-0.00298	-29.8	0.01
		+ 10 min.	13.559596	-0.000404	-0.00298	-29.8	0.01
10	120	Power on	13.559596	-0.000404	-0.00298	-29.8	0.01
		+ 2 min.	13.559605	-0.000395	-0.00291	-29.1	0.01
		+ 5 min.	13.559606	-0.000394	-0.00291	-29.1	0.01
		+ 10 min.	13.559606	-0.000394	-0.00291	-29.1	0.01
0	120	Power on	13.559579	-0.000421	-0.00310	-31.0	0.01
		+ 2 min.	13.559592	-0.000408	-0.00301	-30.1	0.01
		+ 5 min.	13.559604	-0.000396	-0.00292	-29.2	0.01
		+ 10 min.	13.559606	-0.000394	-0.00291	-29.1	0.01
-10	120	Power on	13.559533	-0.000467	-0.00344	-34.4	0.01
		+ 2 min.	13.559563	-0.000437	-0.00322	-32.2	0.01
		+ 5 min.	13.559584	-0.000416	-0.00307	-30.7	0.01
		+ 10 min.	13.559592	-0.000408	-0.00301	-30.1	0.01
-20	120	Power on	13.559557	-0.000443	-0.00327	-32.7	0.01
		+ 2 min.	13.559558	-0.000442	-0.00326	-32.6	0.01
		+ 5 min.	13.559549	-0.000451	-0.00333	-33.3	0.01
		+ 10 min.	13.559560	-0.000440	-0.00324	-32.4	0.01

Calculation formula: Frequency error = Measured frequency - Tested frequency
Result [%] = Frequency error / Tested frequency * 100

*The test was begun from 50 deg.C and the temperature was lowered each 10 deg.C.

APPENDIX 2: Test instruments

EMI test equipment

Control No.	Instrument	Manufacturer	Model No	Serial No	Test Item	Calibration Date * Interval(month)
MAEC-04	Semi Anechoic Chamber(NSA)	TDK	Semi Anechoic Chamber 3m	DA-10005	RE	2015/10/02 * 12
MOS-15	Thermo-Hygrometer	Custom	CTH-180	1501	RE	2016/01/21 * 12
MJM-26	Measure	KOMELON	KMC-36	-	RE	-
COTS-MEMI	EMI measurement program	TSJ	TEPTO-DV	-	RE	-
MTR-10	EMI Test Receiver	Rohde & Schwarz	ESR26	101408	RE	2016/01/29 * 12
MBA-05	Biconical Antenna	Schwarzbeck	BBA9106	1302	RE	2015/11/02 * 12
MLA-23	Logperiodic Antenna(200-1000MHz)	Schwarzbeck	VUSLP9111B	911B-192	RE	2016/01/30 * 12
MCC-50	Coaxial Cable	UL Japan	-	-	RE	2016/06/20 * 12
MAT-68	Attenuator	Anritsu	MP721B	6200961025	RE	2015/11/12 * 12
MPA-14	Pre Amplifier	SONOMA INSTRUMENT	310	260833	RE	2016/03/18 * 12
MMM-10	DIGITAL HiTESTER	Hioki	3805	051201148	RE	2016/01/18 * 12
LP-01	Loop Antenna	Rohde & Schwarz	HFH2-Z2	829425/014	RE	2016/01/28 * 12
MCC-113	Coaxial cable	Fujikura/Suhner/TSJ	5D-2W(10m)/SFM141(5m)/421-010(1m)/suoform141-PE(1m)/RFM-E121(Switcher)	-/04178	RE	2016/07/20 * 12
MCC-64	Coaxial Cable	UL Japan	-	-	RE	2016/03/10 * 12
MRENT-126	Spectrum Analyzer	KEYSIGHT	E4440A	MY46185516	RE	2016/07/01 * 12
MLS-23	LISN(AMN)	Schwarzbeck	NSLK8127	8127-729	CE(EUT or AE)	2016/07/07 * 12
MLS-24	LISN(AMN)	Schwarzbeck	NSLK8127	8127-730	CE(EUT or AE)	2016/07/11 * 12
MTA-52	Terminator	TME	CT-01BP	-	CE	2015/12/01 * 12
MAT-67	Attenuator	JFW Industries, Inc.	50FP-013H2 N	-	CE	2016/01/14 * 12
MCH-02	Temperature and Humidity Chamber	Tabai Espec	PL-4KP	14005424	FT	2016/01/26 * 12
MLPA-07	Loop Antenna	UL Japan	-	-	FT	Pre Check
MSA-15	Spectrum Analyzer	Agilent	E4440A	MY46187105	FT	2016/10/13 * 12

The expiration date of the calibration is the end of the expired month.

All equipment is calibrated with valid calibrations. Each measurement data is traceable to the national or international standards.

As for some calibrations performed after the tested dates, those test equipment have been controlled by means of an unbroken chains of calibrations.

**Test Item: CE: Conducted Emission
RE: Radiated Emission
FT: Frequency Tolerance**

UL Japan, Inc.

Ise EMC Lab.

4383-326 Asama-cho, Ise-shi, Mie-ken 516-0021 JAPAN

Telephone : +81 596 24 8999

Facsimile : +81 596 24 8124