



FCC RF Test Report

APPLICANT : Nest Labs Inc.
EQUIPMENT : Nest Hello
MODEL NAME : A0077
FCC ID : ZQANC51
STANDARD : FCC Part 15 Subpart C §15.247
CLASSIFICATION : (DTS) Digital Transmission System

The product was completed on Oct. 24, 2017. We, SPORTON INTERNATIONAL INC., would like to declare that the tested sample has been evaluated in accordance with the test procedures and has been in compliance with the applicable technical standards.

The test results in this report apply exclusively to the tested model / sample. Without written approval of SPORTON INTERNATIONAL INC., the test report shall not be reproduced except in full.

Reviewed by: Joseph Lin / Supervisor

Approved by: Jones Tsai / Manager



SPORTON INTERNATIONAL INC.

No. 52, Hwa Ya 1st Rd., Hwa Ya Technology Park, Kwei-Shan District, Tao Yuan City, Taiwan, R.O.C.

SPORTON INTERNATIONAL INC.

TEL : 886-3-327-3456

FAX : 886-3-328-4978

FCC ID : ZQANC51

Page Number : 1 of 58

Report Issued Date : Nov. 09, 2017

Report Version : Rev. 03

Report Template No.: BU5-FR15CWLAC MA Version 2.0



TABLE OF CONTENTS

REVISION HISTORY..... 3

SUMMARY OF TEST RESULT 4

1 GENERAL DESCRIPTION 5

 1.1 Applicant 5

 1.2 Product Feature of Equipment Under Test..... 5

 1.3 Modification of EUT 5

 1.4 Testing Location 6

 1.5 Applicable Standards..... 6

2 TEST CONFIGURATION OF EQUIPMENT UNDER TEST 7

 2.1 Carrier Frequency and Channel 7

 2.2 Test Mode 8

 2.3 Connection Diagram of Test System..... 9

 2.4 EUT Operation Test Setup 10

 2.5 Measurement Results Explanation Example..... 10

3 TEST RESULT 11

 3.1 6dB and 99% Bandwidth Measurement 11

 3.2 Peak Output Power Measurement 13

 3.3 Power Spectral Density Measurement 14

 3.4 Conducted Band Edges and Spurious Emission Measurement 17

 3.5 Radiated Band Edges and Spurious Emission Measurement 48

 3.6 AC Conducted Emission Measurement..... 52

 3.7 Antenna Requirements 56

4 LIST OF MEASURING EQUIPMENT 57

5 UNCERTAINTY OF EVALUATION 58

APPENDIX A. CONDUCTED TEST RESULTS

APPENDIX B. RADIATED SPURIOUS EMISSION

APPENDIX C. RADIATED SPURIOUS EMISSION PLOTS

APPENDIX D. DUTY CYCLE PLOTS



SUMMARY OF TEST RESULT

Report Section	FCC Rule	Description	Limit	Result
3.1	15.247(a)(2)	6dB Bandwidth	$\geq 0.5\text{MHz}$	Pass
3.1	-	99% Bandwidth	-	Pass
3.2	15.247(b)	Power Output Measurement	$\leq 30\text{dBm}$	Pass
3.3	15.247(e)	Power Spectral Density	$\leq 8\text{dBm}/3\text{kHz}$	Pass
3.4	15.247(d)	Conducted Band Edges	$\leq 20\text{dBc}$	Pass
		Conducted Spurious Emission		Pass
3.5	15.247(d)	Radiated Band Edges and Radiated Spurious Emission	15.209(a) & 15.247(d)	Pass
3.6	15.207	AC Conducted Emission	15.207(a)	Pass
3.7	15.203 & 15.247(b)	Antenna Requirement	N/A	Pass



1 General Description

1.1 Applicant

Nest Labs Inc.
3400 Hillview Ave.Palo Alto, CA 94304 USA

1.2 Product Feature of Equipment Under Test

Bluetooth, Wi-Fi 2.4GHz 802.11b/g/n/ac, Wi-Fi 5GHz 802.11a/n/ac and Zigbee

Product Specification subjective to this standard	
Antenna Type	WLAN: IFA Antenna Bluetooth: IFA Antenna Zigbee: IFA Antenna

1.3 Modification of EUT

No modifications are made to the EUT during all test items.



1.4 Testing Location

Sporton Lab is accredited to ISO 17025 by Taiwan Accreditation Foundation (TAF code : 1190) and the FCC designation No. TW1190 and TW0007 under the FCC 2.948(e) by Mutual Recognition Agreement (MRA) in FCC Test.

Test Site	SPORTON INTERNATIONAL INC.	
Test Site Location	No. 52, Hwa Ya 1 st Rd., Hwa Ya Technology Park, Kwei-Shan District, Tao Yuan City, Taiwan, R.O.C. TEL: +886-3-327-3456 FAX: +886-3-328-4978	
Test Site No.	Sporton Site No.	
	TH05-HY	CO05-HY

Note: The test site complies with ANSI C63.4 2014 requirement.

Test Site	SPORTON INTERNATIONAL INC.	
Test Site Location	No.58, Aly. 75, Ln. 564, Wenhua 3rd Rd. Guishan Dist, Taoyuan City, Taiwan (R.O.C.) TEL: +886-3-327-0868 FAX: +886-3-327-0855	
Test Site No.	Sporton Site No.	
	03CH11-HY	

Note: The test site complies with ANSI C63.4 2014 requirement.

1.5 Applicable Standards

According to the specifications of the manufacturer, the EUT must comply with the requirements of the following standards:

- ♦ FCC Part 15 Subpart C §15.247
- ♦ FCC KDB Publication No. 558074 D01 DTS Meas. Guidance v04
- ♦ FCC KDB 662911 D01 Multiple Transmitter Output v02r01.
- ♦ ANSI C63.10-2013

Remark: All test items were verified and recorded according to the standards and without any deviation during the test.



2 Test Configuration of Equipment Under Test

- a. The EUT has been associated with peripherals and configuration operated in a manner tended to maximize its emission characteristics in a typical application. Frequency range investigated: conduction emission (150 kHz to 30 MHz), radiation emission (9 kHz to the 10th harmonic of the highest fundamental frequency or to 40 GHz, whichever is lower). For radiated measurement, pre-scanned in three orthogonal panels, X, Y, Z. The worst cases (Z plane) were recorded in this report.

- b. AC power line Conducted Emission was tested under maximum output power.

2.1 Carrier Frequency and Channel

Frequency Band	Channel	Freq. (MHz)	Channel	Freq. (MHz)
2400-2483.5 MHz	1	2412	7	2442
	2	2417	8	2447
	3	2422	9	2452
	4	2427	10	2457
	5	2432	11	2462
	6	2437		



2.2 Test Mode

Final test mode of conducted test items and radiated spurious emissions are considering the modulation and worse data rates as below table.

Single Antenna

Modulation	Data Rate
802.11b	1 Mbps
802.11g	6 Mbps
802.11n HT20	MCS0
802.11ac VHT20	MCS0

MIMO Antenna

Modulation	Data Rate
802.11g	6 Mbps
802.11n HT20	MCS0
802.11ac VHT20	MCS0

Test Cases	
AC Conducted Emission	Mode 1 :WLAN On + BLE On + Zigbee On + Sensor On + LED On + IR LED On + Speaker On + Camera + AC to AC transformer
Remark: The MIMO and 802.11n mode conducted total power has larger 3dB than SISO and 802.11ac mode conducted power, the RSE and conducted test items with MIMO and 802.11n mode condition can also cover the SISO and 802.11ac mode condition.	

2.3 Connection Diagram of Test System

<WLAN Tx Mode>

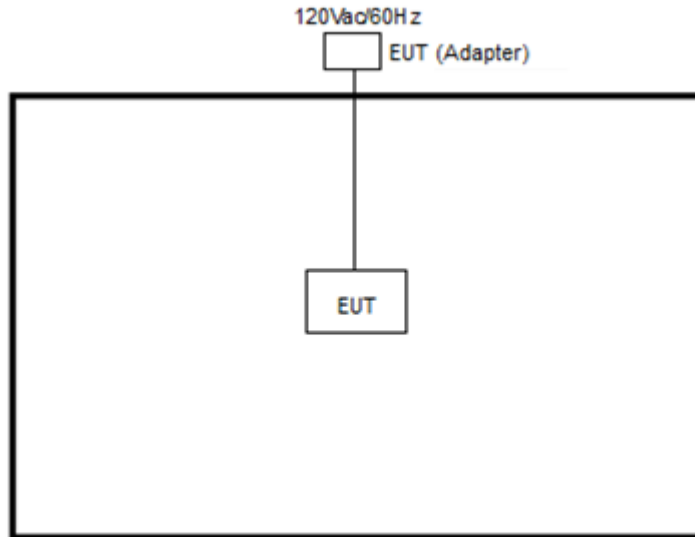

<AC Conducted Emission Mode>

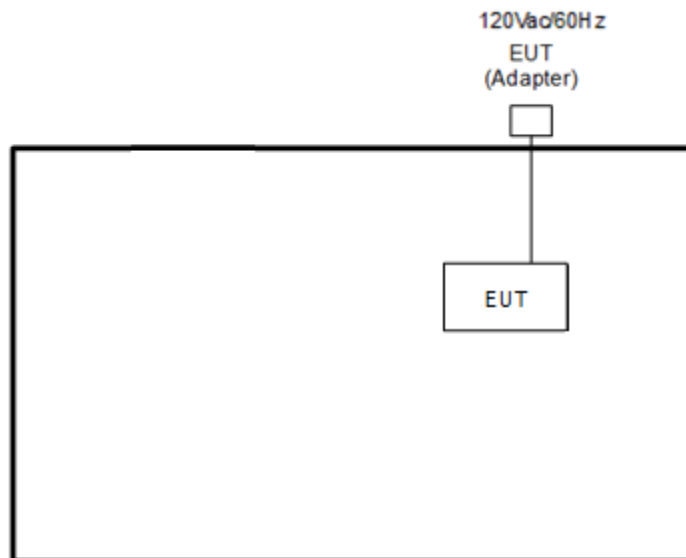



2.4 EUT Operation Test Setup

For WLAN function, programmed RF utility, “tera term” installed in the notebook make the EUT provide functions like channel selection and power level for continuous transmitting and receiving signals.

2.5 Measurement Results Explanation Example

For all conducted test items:

The offset level is set in the spectrum analyzer to compensate the RF cable loss and attenuator factor between EUT conducted output port and spectrum analyzer. With the offset compensation, the spectrum analyzer reading level is exactly the EUT RF output level.

Example:

The spectrum analyzer offset is derived from RF cable loss and attenuator factor.

Offset = RF cable loss + attenuator factor.

Following shows an offset computation example with cable loss 4.2 dB and 10dB attenuator.

$$\begin{aligned} \text{Offset(dB)} &= \text{RF cable loss(dB)} + \text{attenuator factor(dB)}. \\ &= 4.2 + 10 = 14.2 \text{ (dB)} \end{aligned}$$

3 Test Result

3.1 6dB and 99% Bandwidth Measurement

3.1.1 Limit of 6dB and 99% Bandwidth

The minimum 6 dB bandwidth shall be at least 500 kHz.

3.1.2 Measuring Instruments

The measuring equipment is listed in the section 4 of this test report.

3.1.3 Test Procedures

1. The testing follows FCC KDB Publication No. 558074 DTS D01 Meas. Guidance v04.
2. The RF output of EUT was connected to the spectrum analyzer by RF cable and attenuator. The path loss was compensated to the results for each measurement.
3. Set to the maximum power setting and enable the EUT transmit continuously.
4. Make the measurement with the spectrum analyzer's resolution bandwidth (RBW) = 100 kHz. Set the Video bandwidth (VBW) = 300 kHz. In order to make an accurate measurement. The 6 dB bandwidth must be greater than 500 kHz.
5. For 99% Bandwidth Measurement, the spectrum analyzer's resolution bandwidth (RBW) = 1MHz and set the Video bandwidth (VBW) = 3MHz.
6. Measure and record the results in the test report.

3.1.4 Test Setup





3.1.5 Test Result of 6dB and 99% Occupied Bandwidth

Please refer to Appendix A.

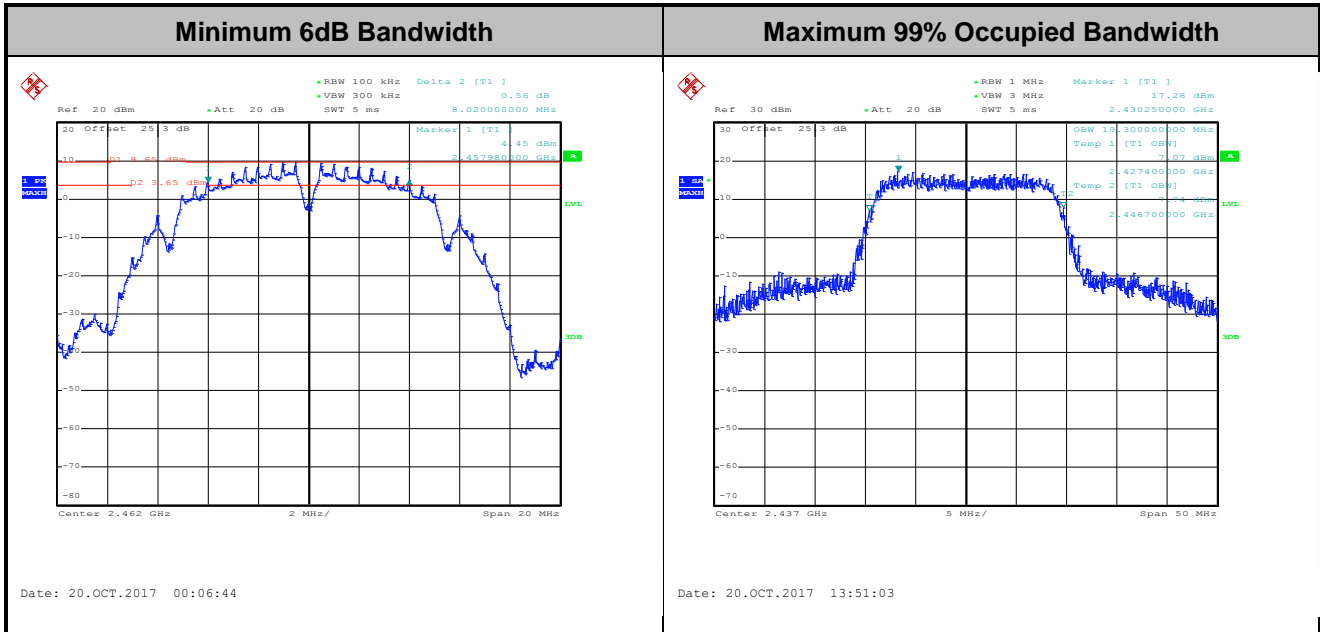

Note : The occupied channel bandwidth is maintained within the band of operation for all of the modulations.

3.2 Peak Output Power Measurement

3.2.1 Limit of Peak Output Power

For systems using digital modulation in the 2400-2483.5MHz, the limit for peak output power is 30dBm. If transmitting antenna with directional gain greater than 6dBi is used, the peak output power from the intentional radiator shall be reduced below the above stated value by the amount in dB that the directional gain of the antenna exceeds 6 dBi. In case of point-to-point operation, the limit has to be reduced by 1dB for every 3dB that the directional gain of the antenna exceeds 6dBi.

3.2.2 Measuring Instruments

The measuring equipment is listed in the section 4 of this test report.

3.2.3 Test Procedures

1. The testing follows the Measurement Procedure of FCC KDB No. 558074 DTS D01 Meas. Guidance v04 section 9.1.3 PKPM1 Peak power meter method.
2. The RF output of EUT was connected to the power meter by RF cable and attenuator. The path loss was compensated to the results for each measurement.
3. Set to the maximum power setting and enable the EUT transmit continuously.
4. Measure the conducted output power and record the results in the test report.
5. For MIMO mode, calculation method follows FCC KDB 662911 D01 Multiple Transmitter Output v02r01.

3.2.4 Test Setup

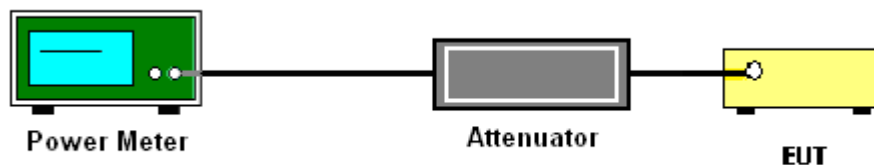

3.2.5 Test Result of Peak Output Power

Please refer to Appendix A.

3.2.6 Test Result of Average output Power (Reporting Only)

Please refer to Appendix A.



3.3 Power Spectral Density Measurement

3.3.1 Limit of Power Spectral Density

The peak power spectral density shall not be greater than 8dBm in any 3kHz band at any time interval of continuous transmission.

3.3.2 Measuring Instruments

The measuring equipment is listed in the section 4 of this test report.

3.3.3 Test Procedures

1. The testing follows Measurement Procedure 10.2 Method PKPSD of FCC KDB Publication No. 558074 D01 DTS Meas. Guidance v04
2. The RF output of EUT was connected to the spectrum analyzer by RF cable and attenuator. The path loss was compensated to the results for each measurement.
3. Set to the maximum power setting and enable the EUT transmit continuously.
4. Make the measurement with the spectrum analyzer's resolution bandwidth (RBW) = 3 kHz. Video bandwidth VBW = 10 kHz In order to make an accurate measurement, set the span to 1.5 times DTS Channel Bandwidth. (6dB BW)
5. Detector = peak, Sweep time = auto couple, Trace mode = max hold, Allow trace to fully stabilize. Use the peak marker function to determine the maximum power level.
6. Measure and record the results in the test report.
7. For MIMO mode, calculation method follows FCC KDB 662911 D01 Multiple Transmitter Output v02r01.

If measurements performed using method (2) plus $10 \log(N)$ exceeds the emission limit, the test should choose method (1) before declaring that the device fails the emission limit.

Method (1): Measure and sum the spectra across the outputs.

The total final Power Spectral Density is from a device with 2 transmitter outputs. The spectrum measurements of the individual outputs are all performed with the same span and number of points, the spectrum value in the first spectral bin of output 1 is summed with that in the first spectral bin of output 2 to obtain the value for the first frequency bin of the summed spectrum.

Method (2): Measure and add $10 \log(N)$ dB, where N is the number of outputs. (N=2)

3.3.4 Test Setup

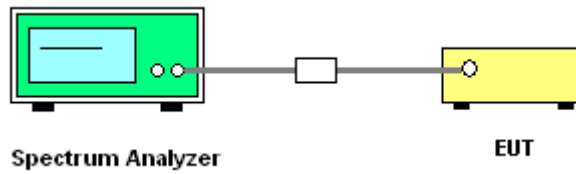

3.3.5 Test Result of Power Spectral Density

Please refer to Appendix A.

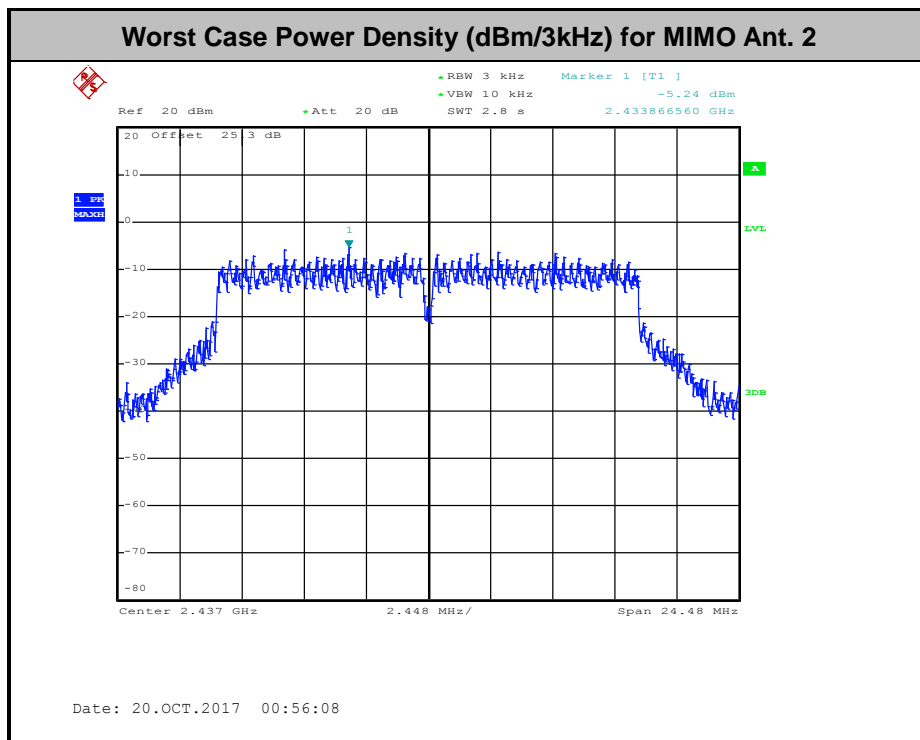
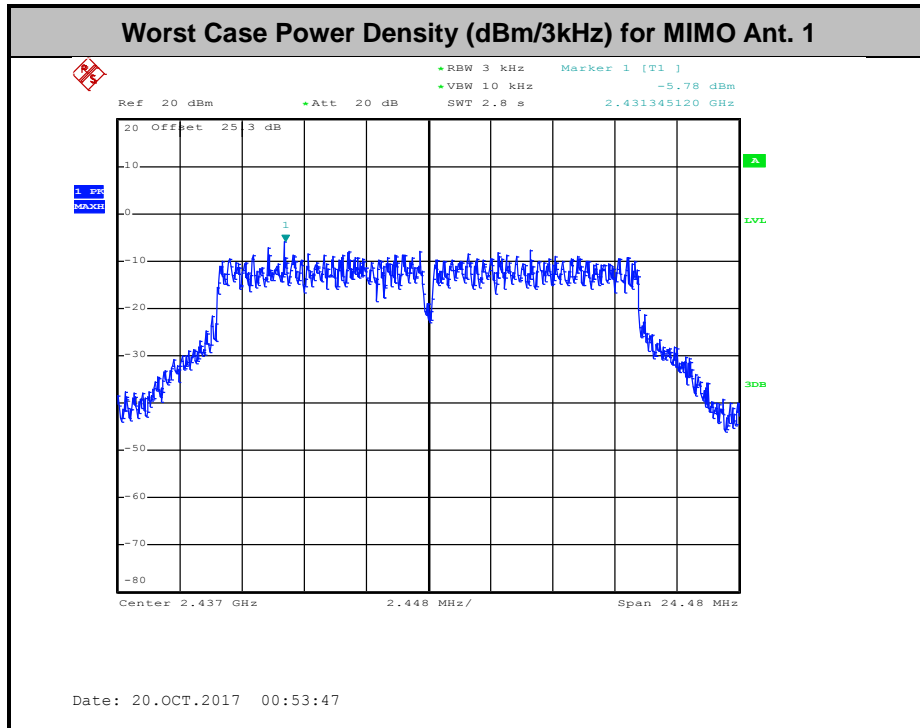

3.4 Conducted Band Edges and Spurious Emission Measurement

3.4.1 Limit of Conducted Band Edges and Spurious Emission Measurement

In any 100 kHz bandwidth outside of the authorized frequency band, the emissions which fall in the non-restricted bands shall be attenuated at least 20 dB / 30dB relative to the maximum PSD level in 100 kHz by RF conducted measurement.

3.4.2 Measuring Instruments

The measuring equipment is listed in the section 4 of this test report.

3.4.3 Test Procedures

1. The testing follows FCC KDB Publication No. 558074 D01 DTS Meas. Guidance v04.
2. The RF output of EUT was connected to the spectrum analyzer by RF cable and attenuator. The path loss was compensated to the results for each measurement.
3. Set to the maximum power setting and enable the EUT transmit continuously.
4. Set RBW = 100 kHz, VBW=300 kHz, Peak Detector. Unwanted Emissions measured in any 100 kHz bandwidth outside of the authorized frequency band shall be attenuated by at least 20 dB relative to the maximum in-band peak PSD level in 100 kHz when maximum peak conducted output power procedure is used. If the transmitter complies with the conducted power limits based on the use of RMS averaging over a time interval, the attenuation required under this paragraph shall be 30 dB instead of 20 dB per 15.247(d).
5. Measure and record the results in the test report.
6. The RF fundamental frequency should be excluded against the limit line in the operating frequency band.

3.4.4 Test Setup

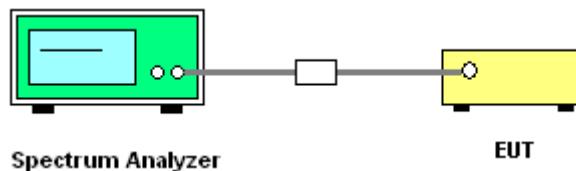



3.4.5 Test Result of Conducted Band Edges and Spurious Emission

Number of TX = 1, Ant. 1 (Measured)

Number of TX	1	Ant. :	1
Test Mode :	802.11b	Temperature :	21~25°C
Test Band :	2.4GHz Low	Relative Humidity :	51~54%
Test Channel :	01	Test Engineer :	Reece Lin and Aking Chang

WLAN 802.11b Channel 01

100kHz PSD reference Level

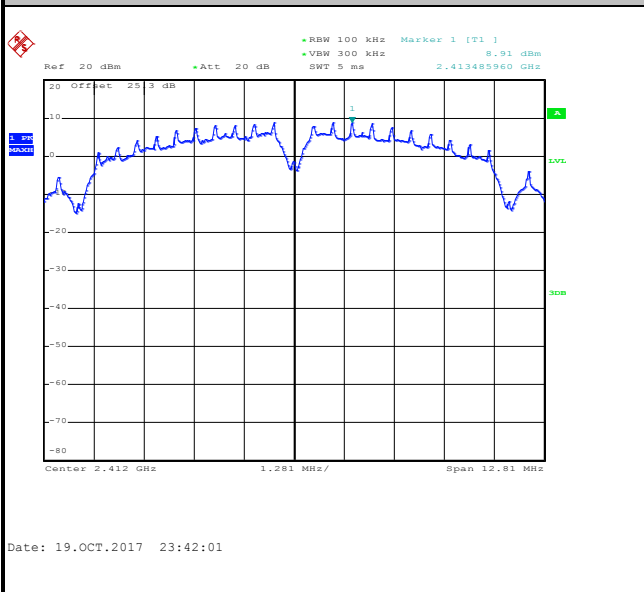

Low Channel Plot

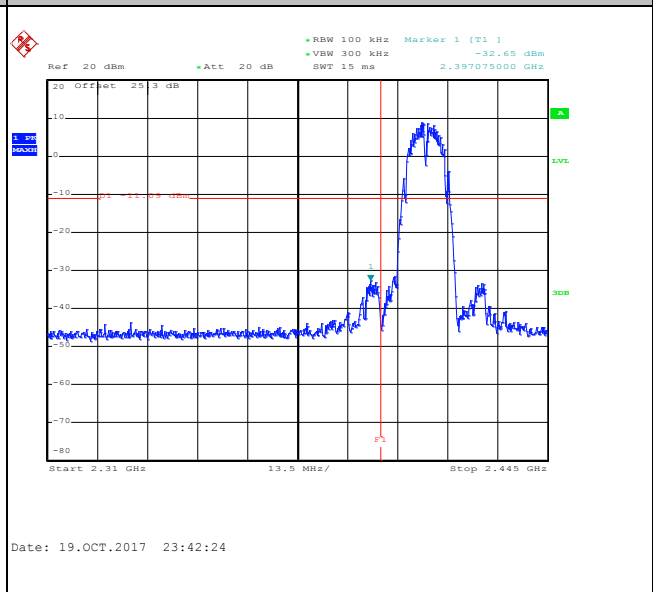

Spurious Emission 30MHz~3GHz

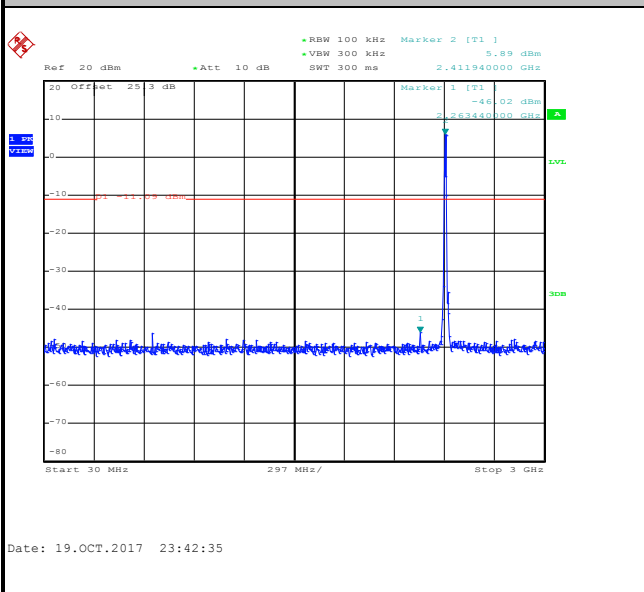

Spurious Emission 2GHz~25GHz

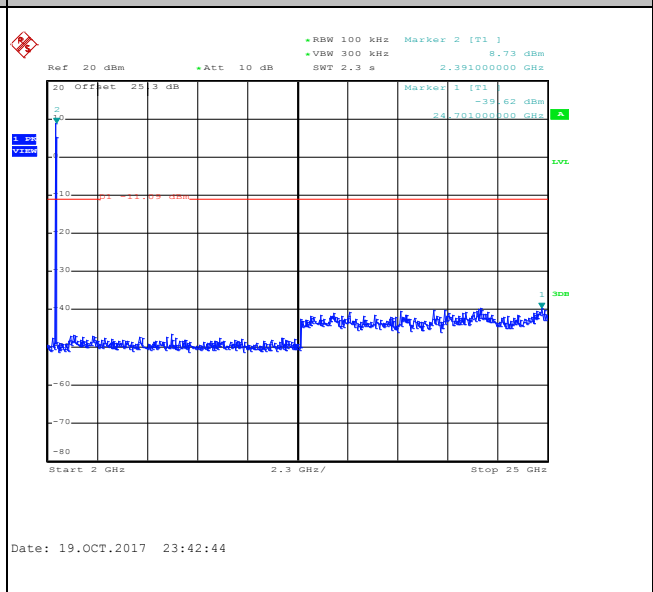



Number of TX :	1	Ant. :	1
Test Mode :	802.11b	Temperature :	21~25°C
Test Band :	2.4GHz Low	Relative Humidity :	51~54%
Test Channel :	02	Test Engineer :	Reece Lin and Aking Chang

WLAN 802.11b Channel 02

100kHz PSD reference Level

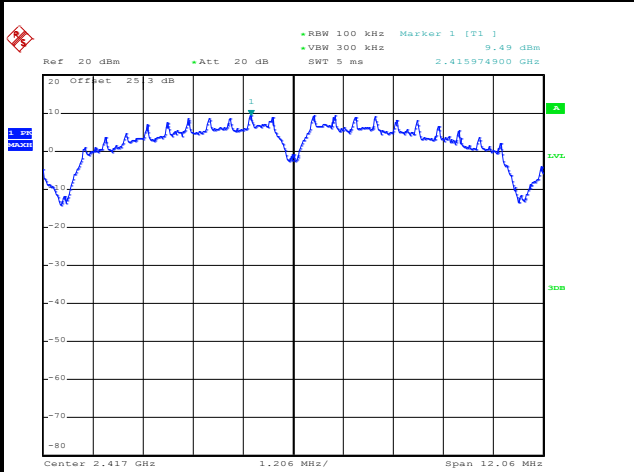

Date: 19.OCT.2017 23:45:12

Mid Channel Plot

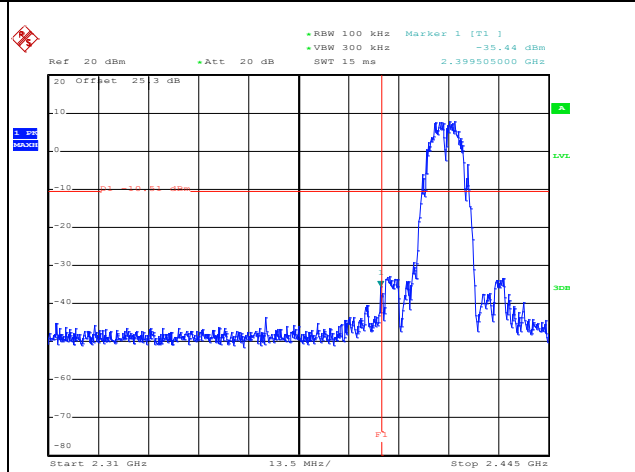

Date: 19.OCT.2017 23:47:40

Spurious Emission 30MHz~3GHz

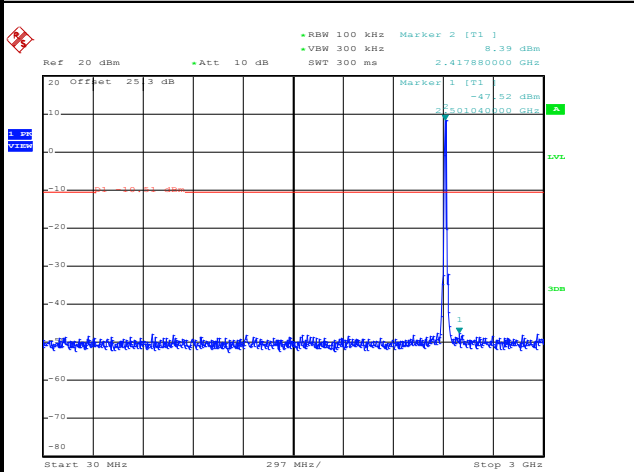

Date: 19.OCT.2017 23:47:56

Spurious Emission 2GHz~25GHz

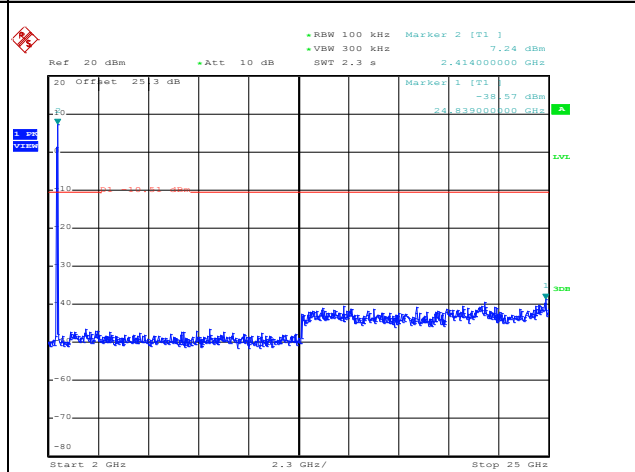

Date: 19.OCT.2017 23:48:04



Number of TX :	1	Ant. :	1
Test Mode :	802.11b	Temperature :	21~25°C
Test Band :	2.4GHz Mid	Relative Humidity :	51~54%
Test Channel :	06	Test Engineer :	Reece Lin and Aking Chang

WLAN 802.11b Channel 06

100kHz PSD reference Level

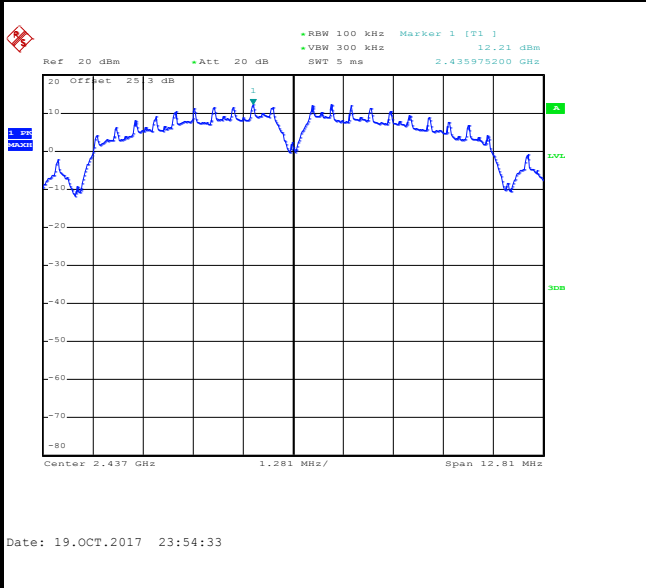

Spurious Emission 30MHz~3GHz

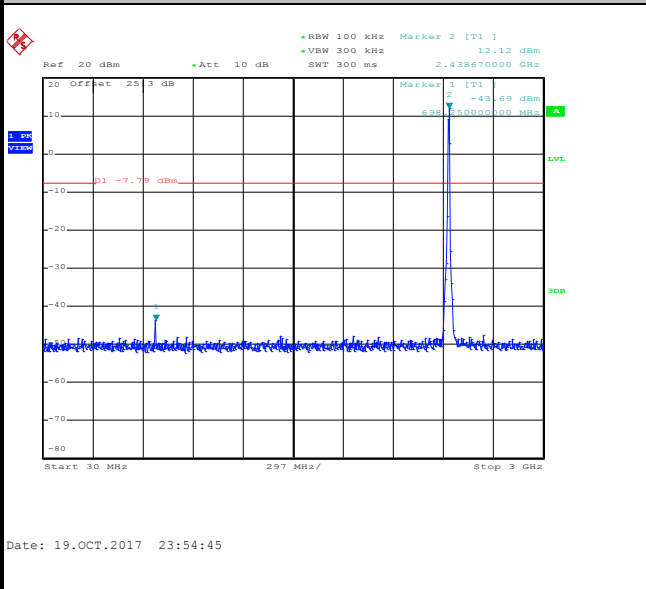

Spurious Emission 2GHz~25GHz

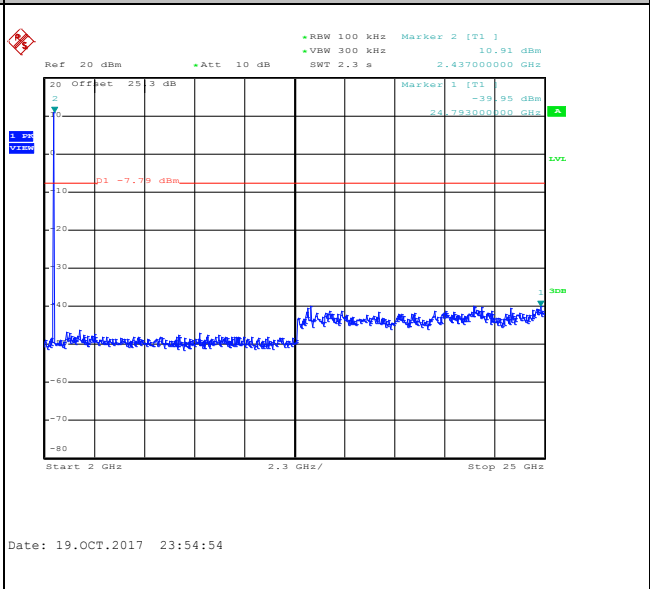



Number of TX :	1	Ant. :	1
Test Mode :	802.11b	Temperature :	21~25°C
Test Band :	2.4GHz High	Relative Humidity :	51~54%
Test Channel :	10	Test Engineer :	Reece Lin and Aking Chang

WLAN 802.11b Channel 10

100kHz PSD reference Level

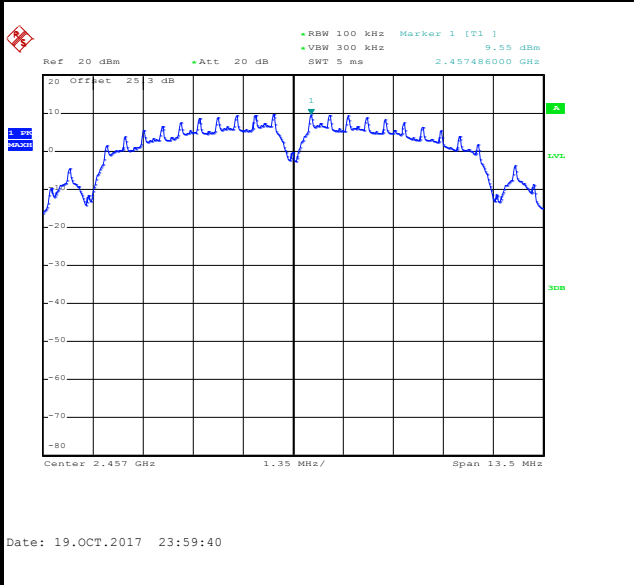

High Channel Plot

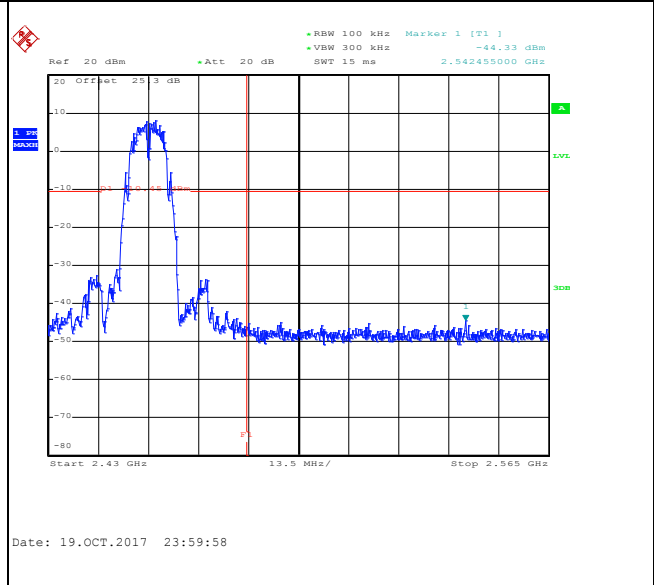

Spurious Emission 30MHz~3GHz

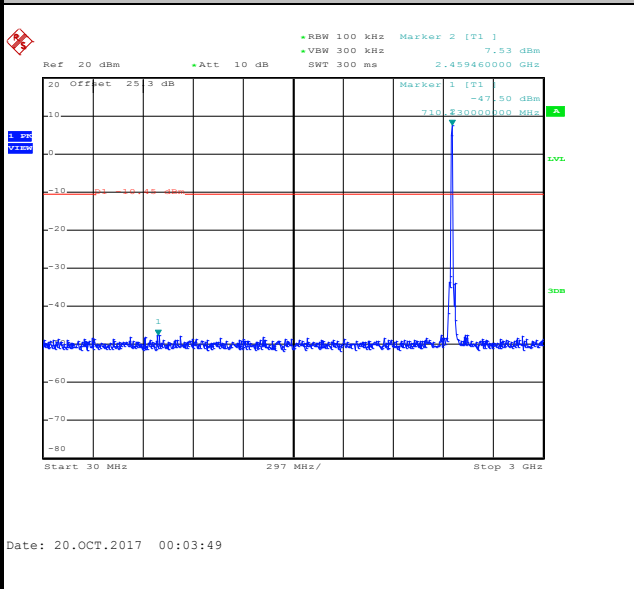

Spurious Emission 2GHz~25GHz

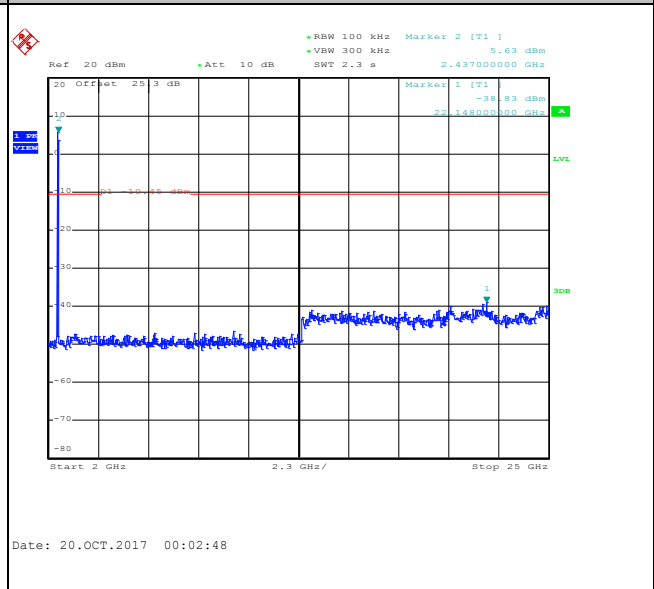



Number of TX :	1	Ant. :	1
Test Mode :	802.11b	Temperature :	21~25°C
Test Band :	2.4GHz High	Relative Humidity :	51~54%
Test Channel :	11	Test Engineer :	Reece Lin and Aking Chang

WLAN 802.11b Channel 11

100kHz PSD reference Level

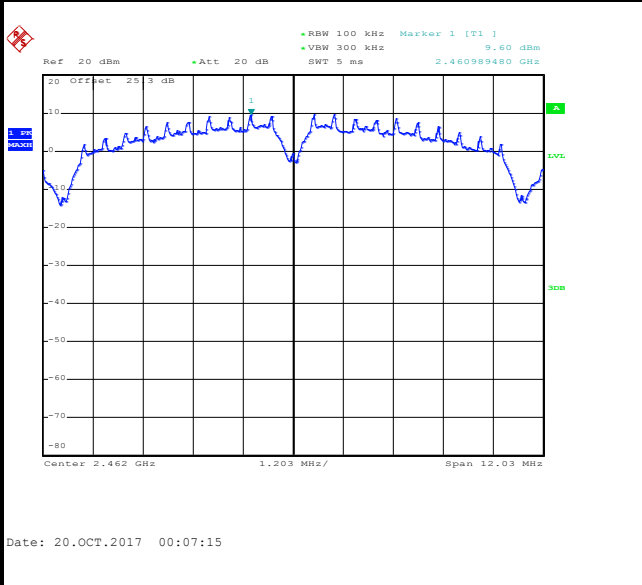

High Channel Plot

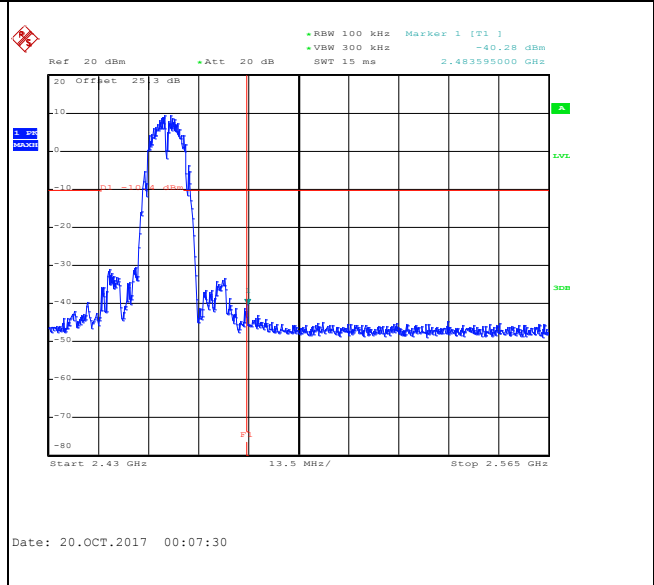

Spurious Emission 30MHz~3GHz

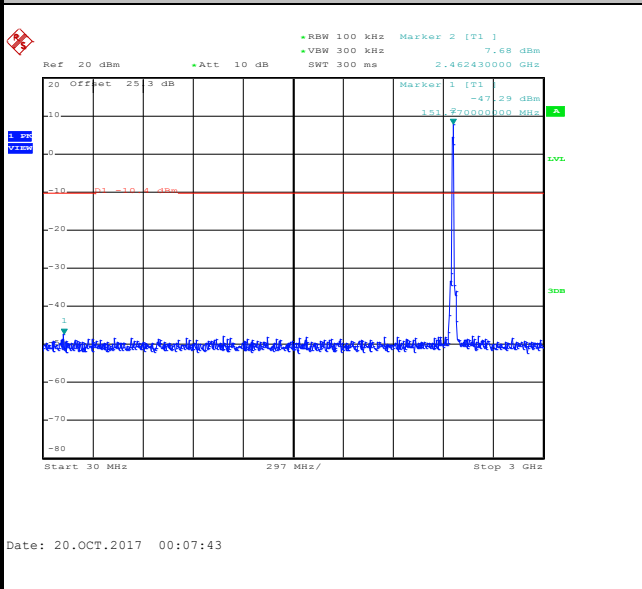

Spurious Emission 2GHz~25GHz

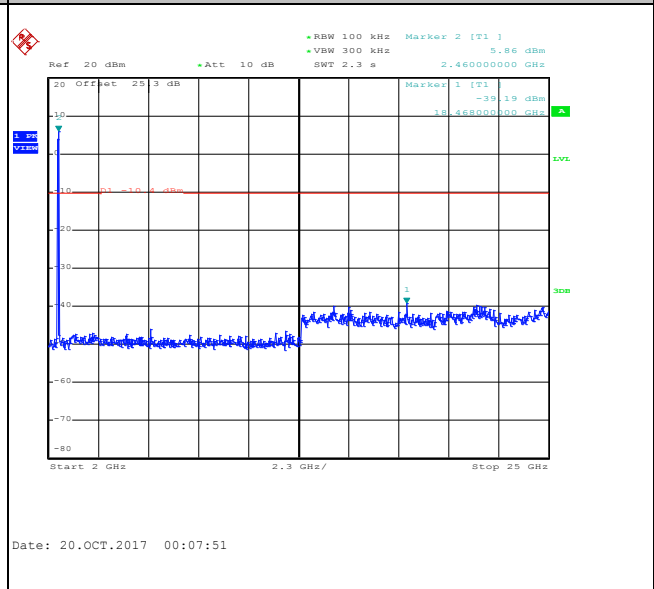



Number of TX = 1, Ant. 2 (Measured)

Number of TX	1	Ant. :	2
Test Mode :	802.11b	Temperature :	21~25°C
Test Band :	2.4GHz Low	Relative Humidity :	51~54%
Test Channel :	01	Test Engineer :	Reece Lin and Aking Chang

WLAN 802.11b Channel 01

100kHz PSD reference Level

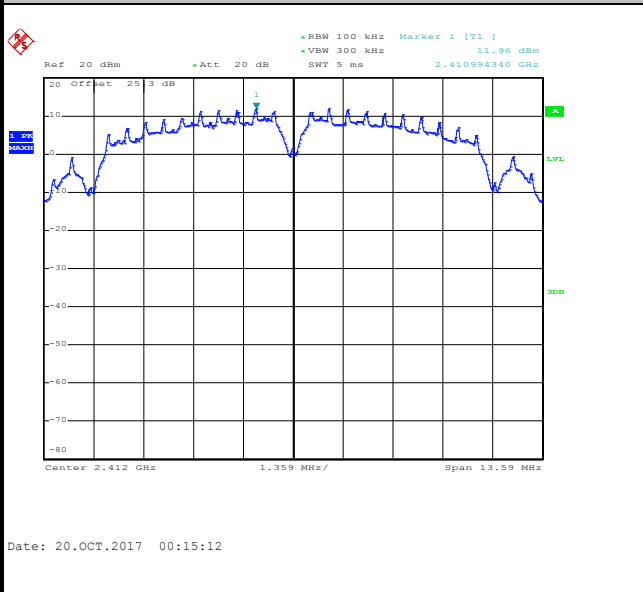

Low Channel Plot

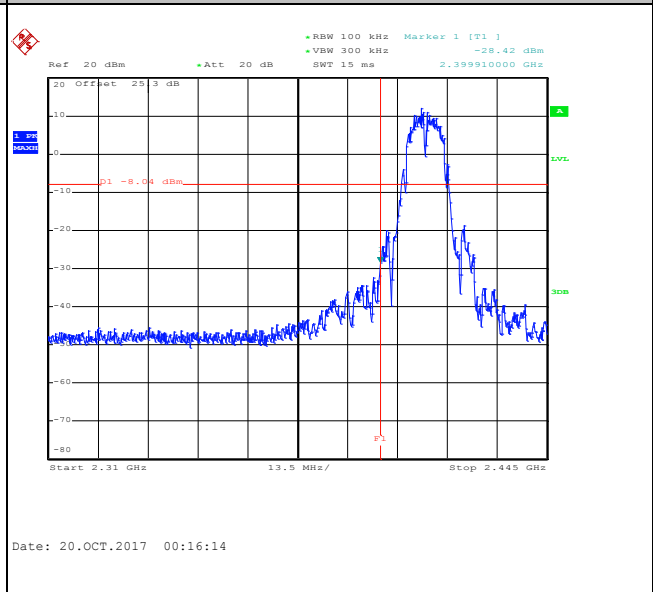

Spurious Emission 30MHz~3GHz

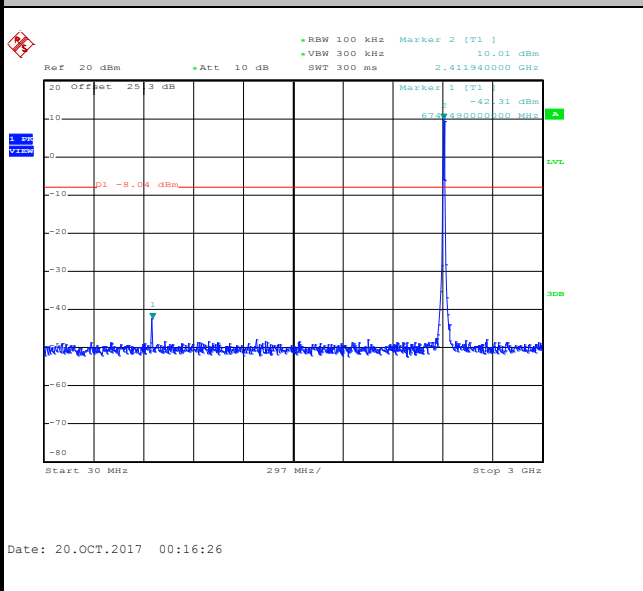

Spurious Emission 2GHz~25GHz

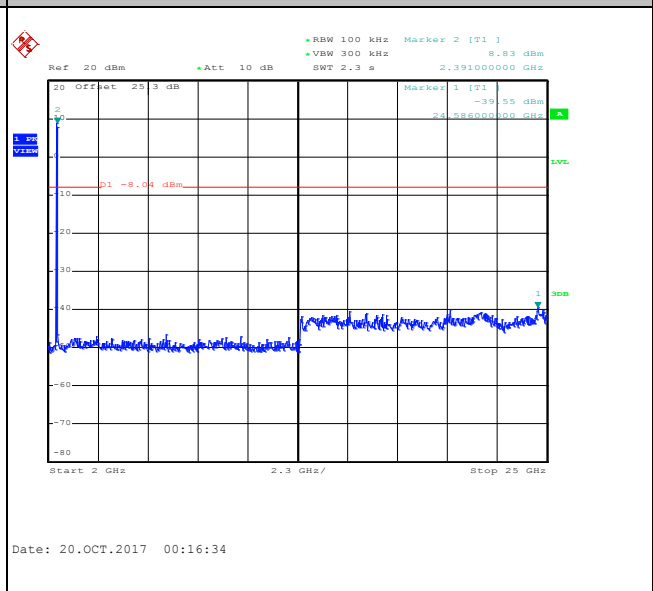



Number of TX	1	Ant. :	2
Test Mode :	802.11b	Temperature :	21~25°C
Test Band :	2.4GHz Low	Relative Humidity :	51~54%
Test Channel :	02	Test Engineer :	Reece Lin and Aking Chang

WLAN 802.11b Channel 02

100kHz PSD reference Level

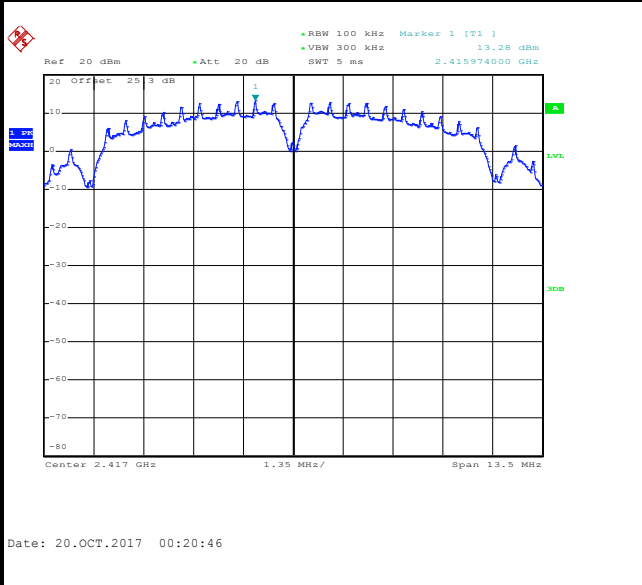

Low Channel Plot

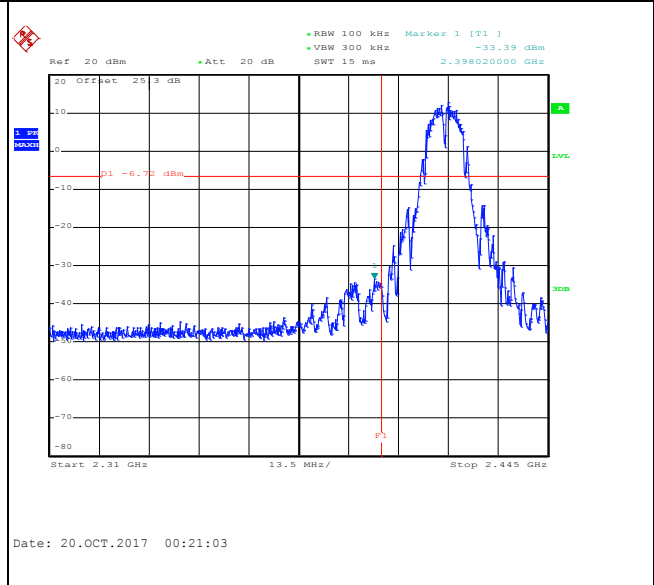

Spurious Emission 30MHz~3GHz

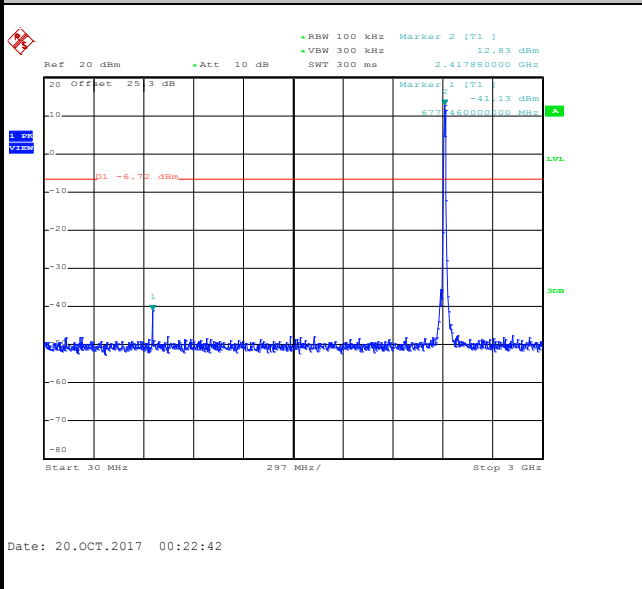

Spurious Emission 2GHz~25GHz

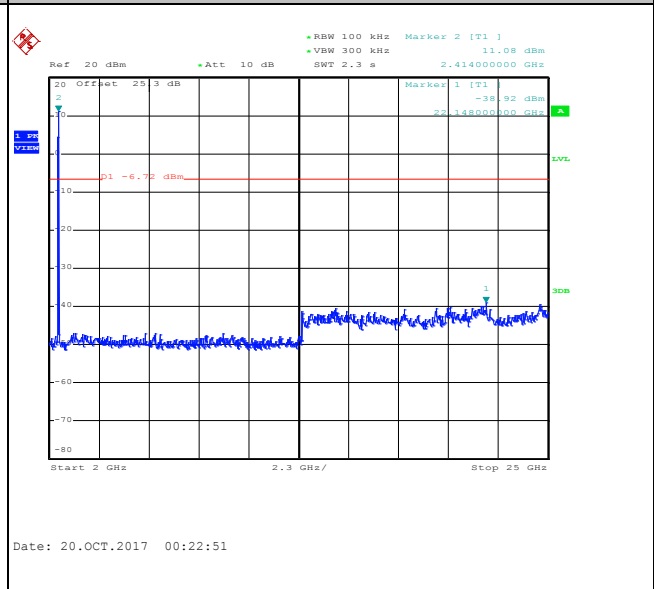



Number of TX :	1	Ant. :	2
Test Mode :	802.11b	Temperature :	21~25°C
Test Band :	2.4GHz Mid	Relative Humidity :	51~54%
Test Channel :	06	Test Engineer :	Reece Lin and Aking Chang

WLAN 802.11b Channel 06

100kHz PSD reference Level

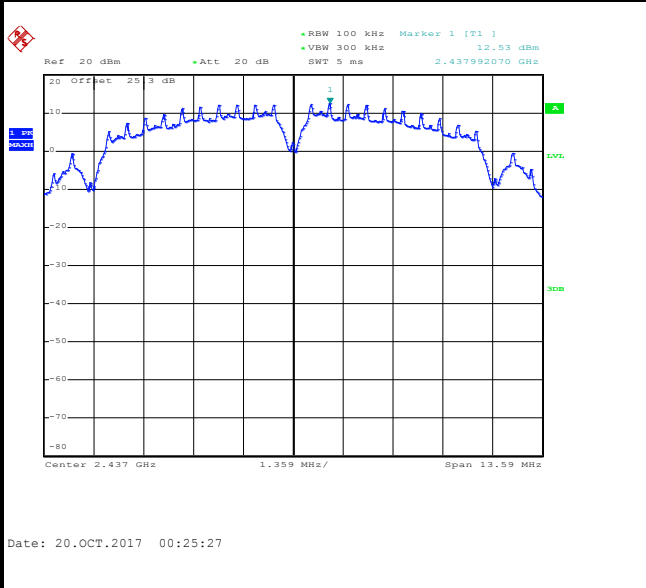

Spurious Emission 30MHz~3GHz

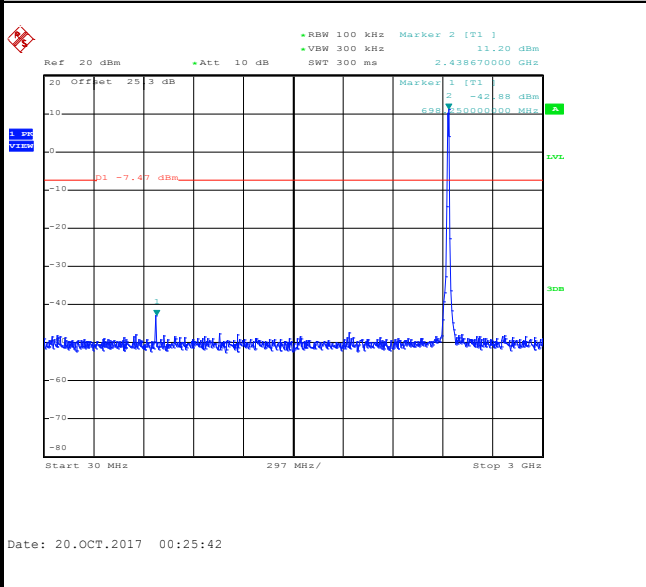

Spurious Emission 2GHz~25GHz

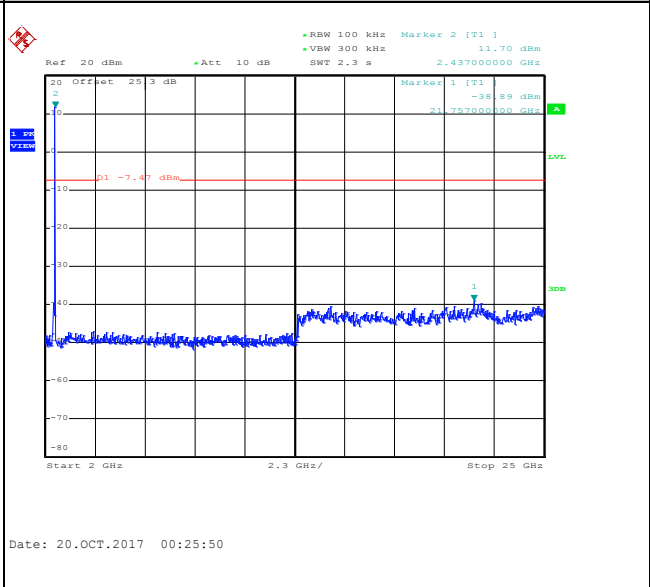



Number of TX :	1	Ant. :	2
Test Mode :	802.11b	Temperature :	21~25°C
Test Band :	2.4GHz High	Relative Humidity :	51~54%
Test Channel :	10	Test Engineer :	Reece Lin and Aking Chang

WLAN 802.11b Channel 10

100kHz PSD reference Level

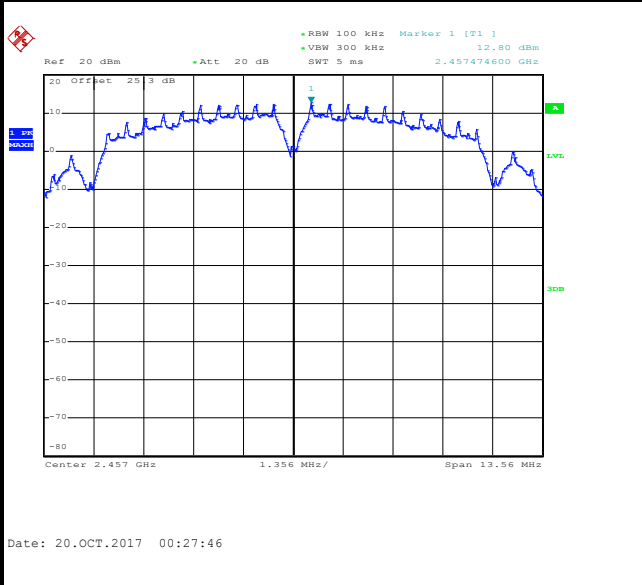

High Channel Plot

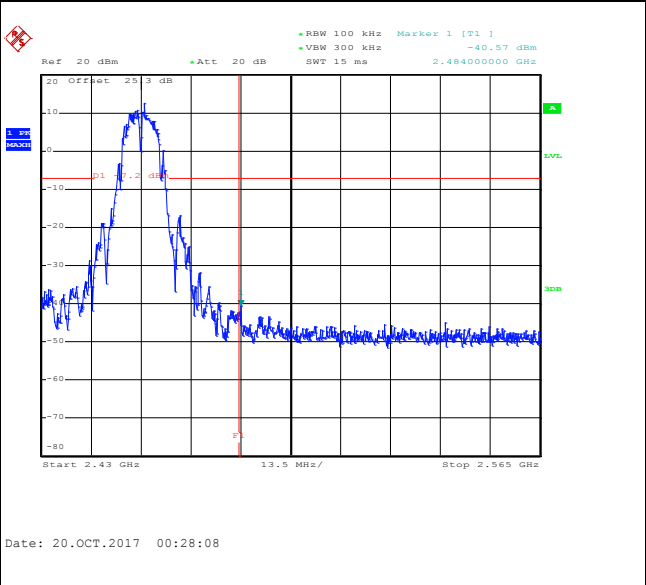

Spurious Emission 30MHz~3GHz

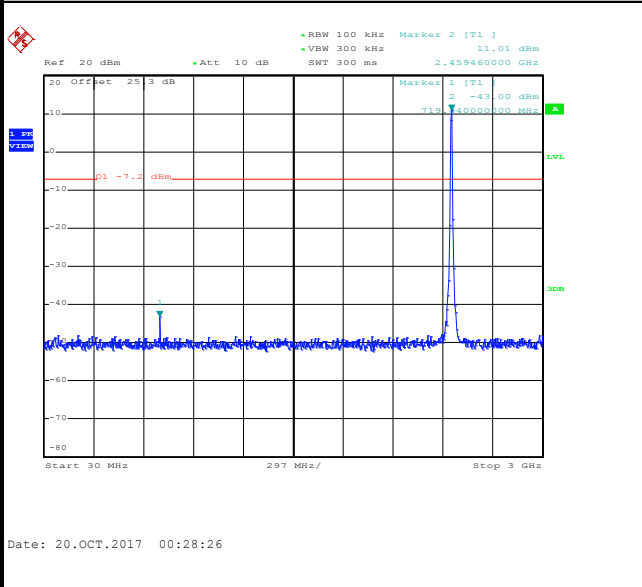

Spurious Emission 2GHz~25GHz

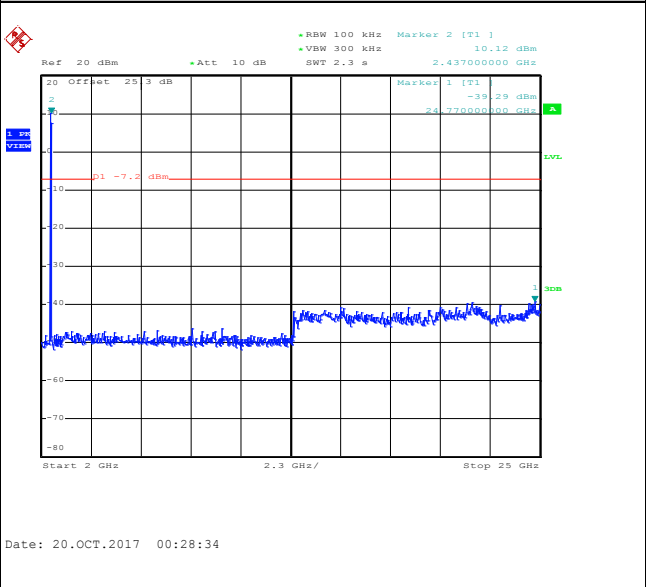



Number of TX :	1	Ant. :	2
Test Mode :	802.11b	Temperature :	21~25°C
Test Band :	2.4GHz High	Relative Humidity :	51~54%
Test Channel :	11	Test Engineer :	Reece Lin and Aking Chang

WLAN 802.11b Channel 11

100kHz PSD reference Level

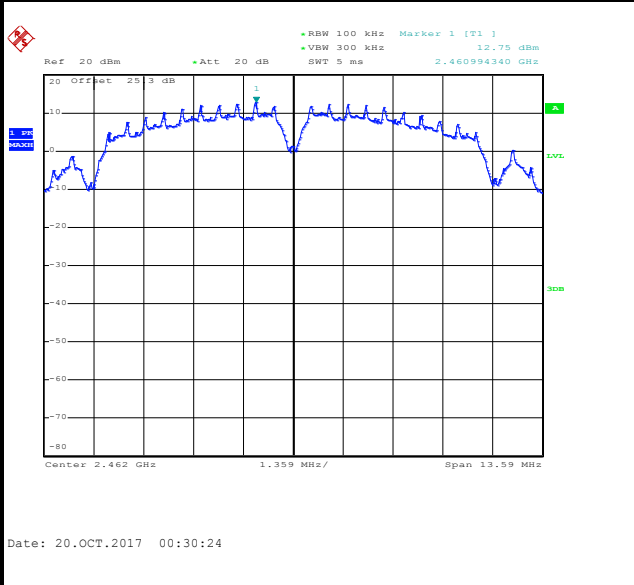

High Channel Plot

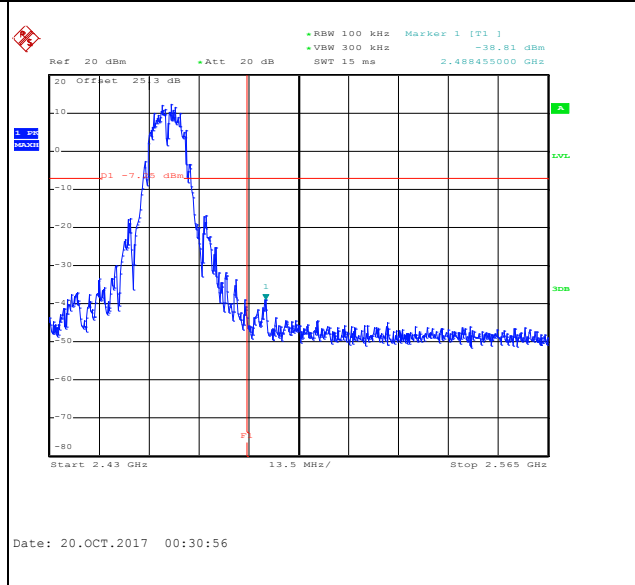

Spurious Emission 30MHz~3GHz

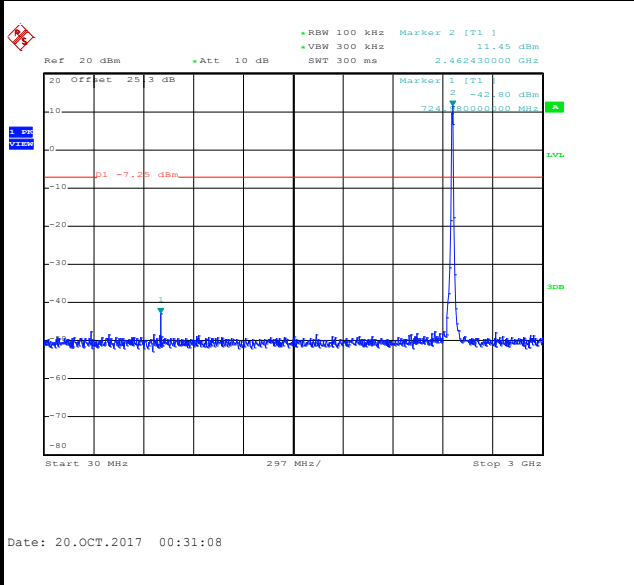

Spurious Emission 2GHz~25GHz

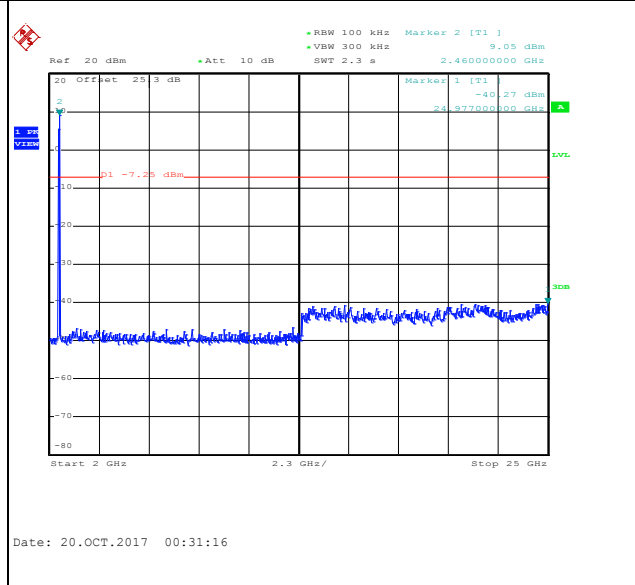



Number of TX = 2, Ant. 1 (Measured)

Number of TX :	2	Ant. :	1
Test Mode :	802.11g	Temperature :	21~25°C
Test Band :	2.4GHz Low	Relative Humidity :	51~54%
Test Channel :	01	Test Engineer :	Reece Lin and Aking Chang

WLAN 802.11g Channel 01

100kHz PSD reference Level

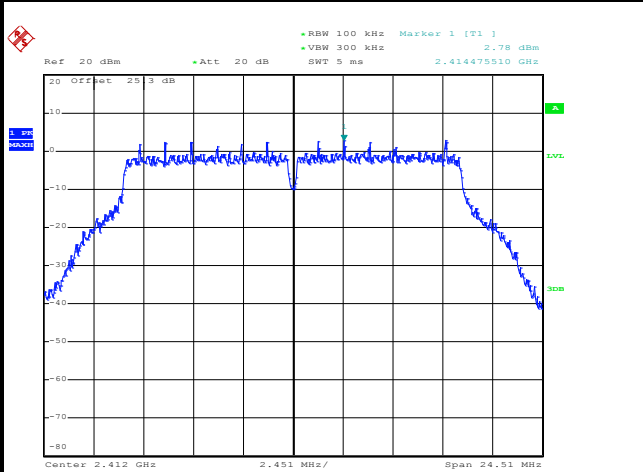

Date: 20.OCT.2017 00:36:07

Low Channel Plot

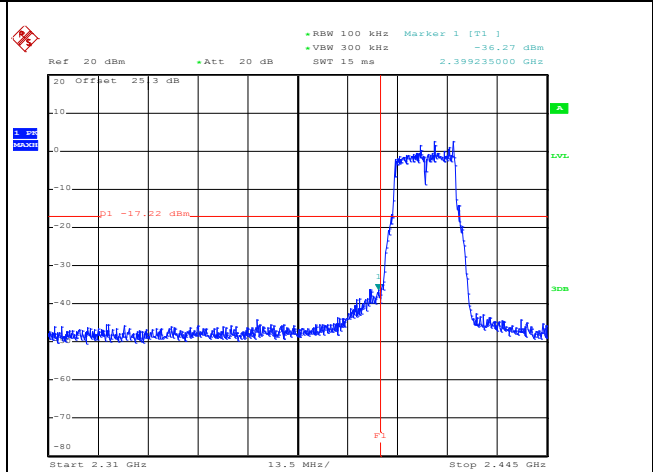

Date: 20.OCT.2017 00:36:16

Spurious Emission 30MHz~3GHz

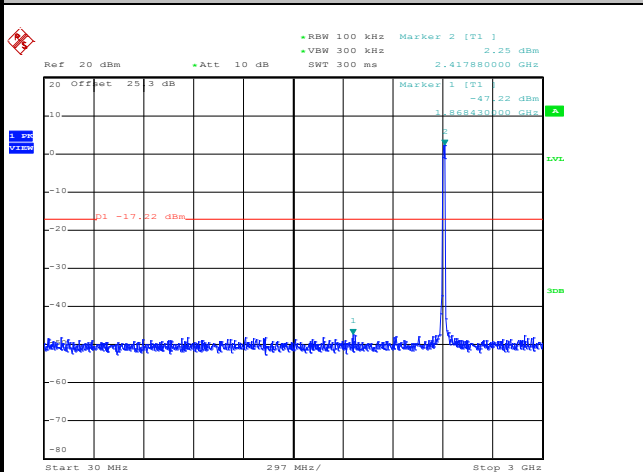

Date: 20.OCT.2017 00:36:27

Spurious Emission 2GHz~25GHz

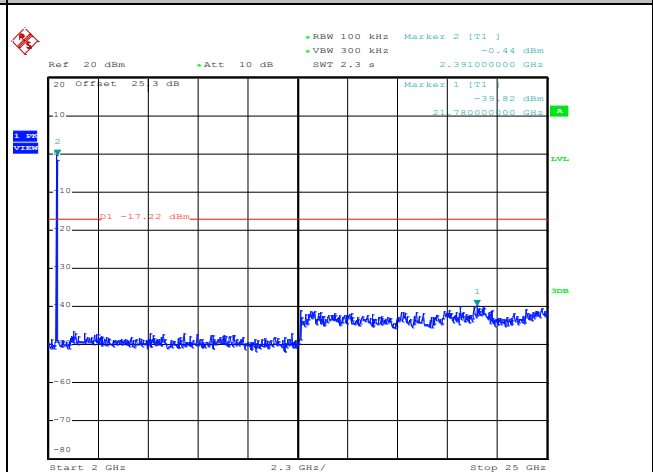

Date: 20.OCT.2017 00:36:36



Number of TX :	2	Ant. :	1
Test Mode :	802.11g	Temperature :	21~25°C
Test Band :	2.4GHz Low	Relative Humidity :	51~54%
Test Channel :	02	Test Engineer :	Reece Lin and Aking Chang

WLAN 802.11g Channel 02

100kHz PSD reference Level

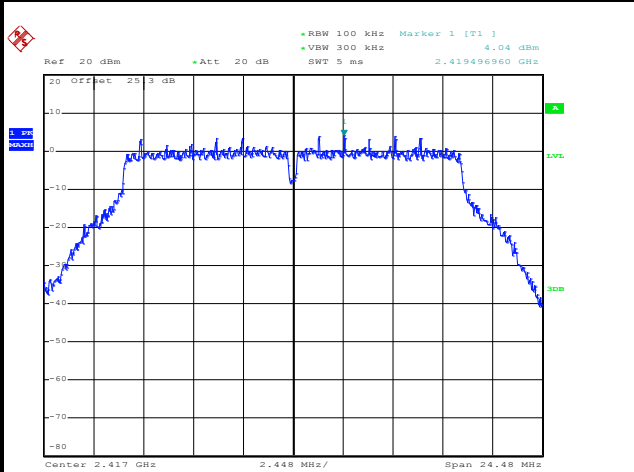

Date: 20.OCT.2017 00:41:42

Low Channel Plot

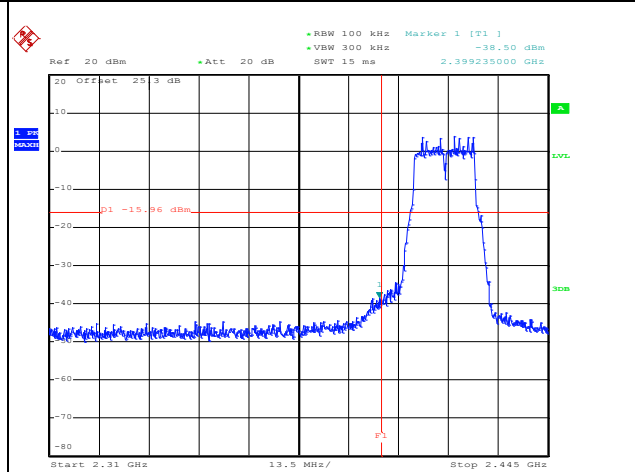

Date: 20.OCT.2017 00:41:55

Spurious Emission 30MHz~3GHz

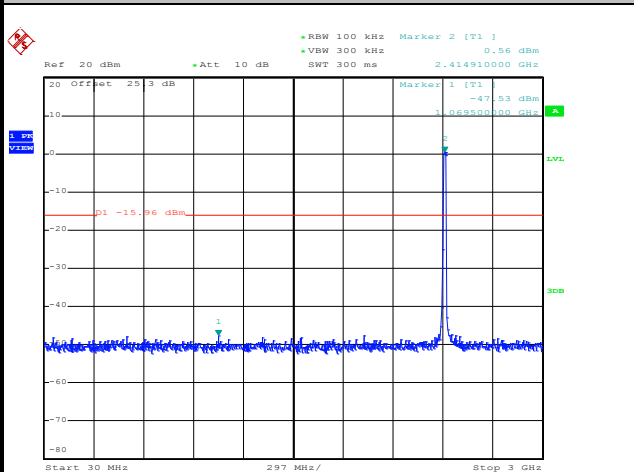

Date: 20.OCT.2017 00:42:28

Spurious Emission 2GHz~25GHz

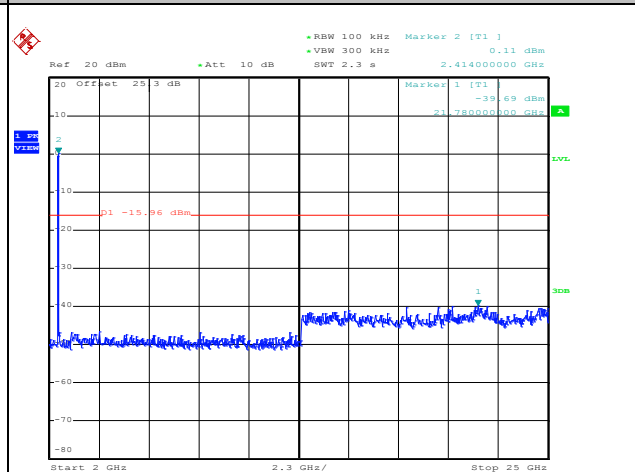

Date: 20.OCT.2017 00:42:36



Number of TX :	2	Ant. :	1
Test Mode :	802.11g	Temperature :	21~25°C
Test Band :	2.4GHz Mid	Relative Humidity :	51~54%
Test Channel :	06	Test Engineer :	Reece Lin and Aking Chang

WLAN 802.11g Channel 06

100kHz PSD reference Level

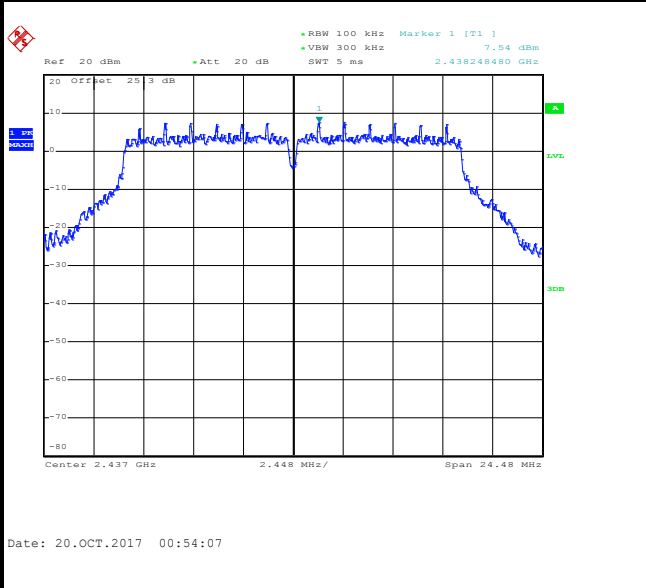

Spurious Emission 30MHz~3GHz

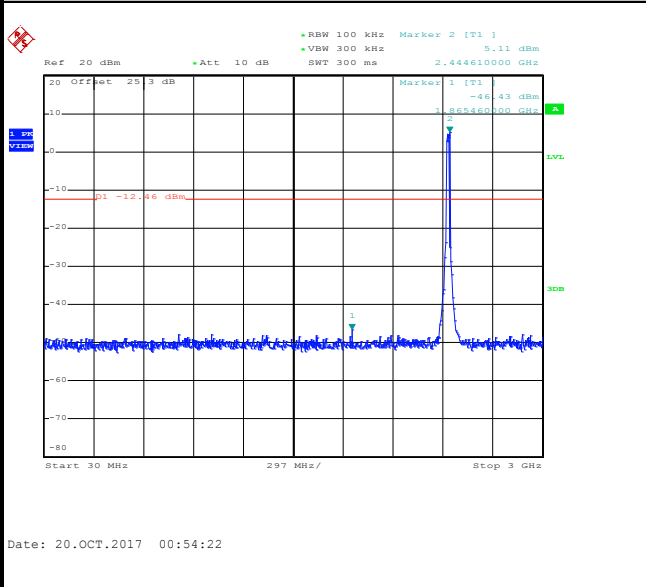

Spurious Emission 2GHz~25GHz

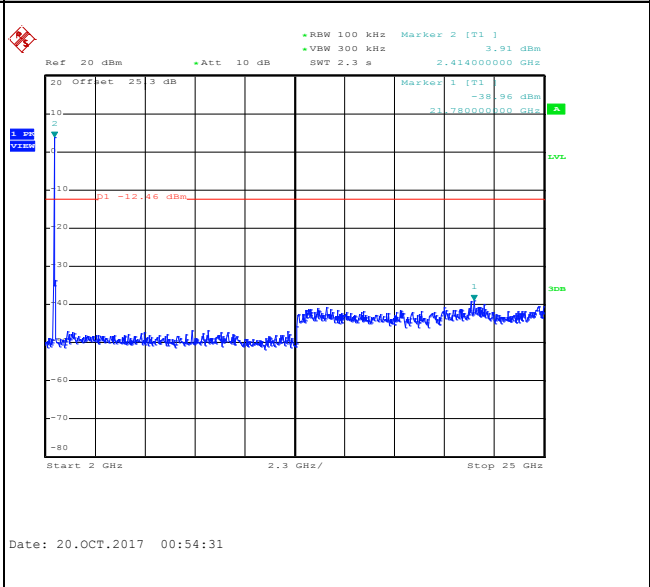



Number of TX :	2	Ant. :	1
Test Mode :	802.11g	Temperature :	21~25°C
Test Band :	2.4GHz High	Relative Humidity :	51~54%
Test Channel :	10	Test Engineer :	Reece Lin and Aking Chang

WLAN 802.11g Channel 10

100kHz PSD reference Level

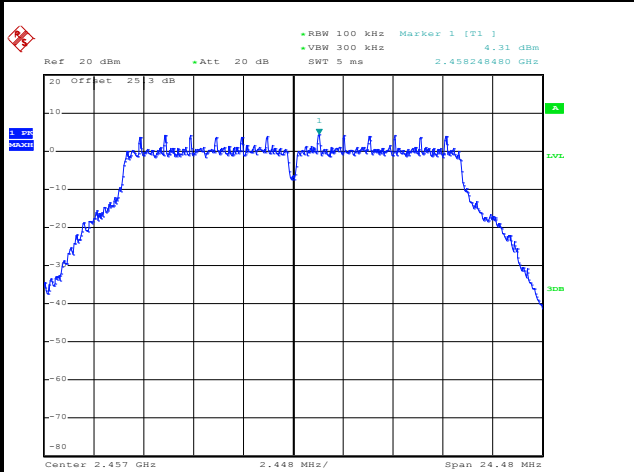

Date: 20.OCT.2017 01:00:24

High Channel Plot

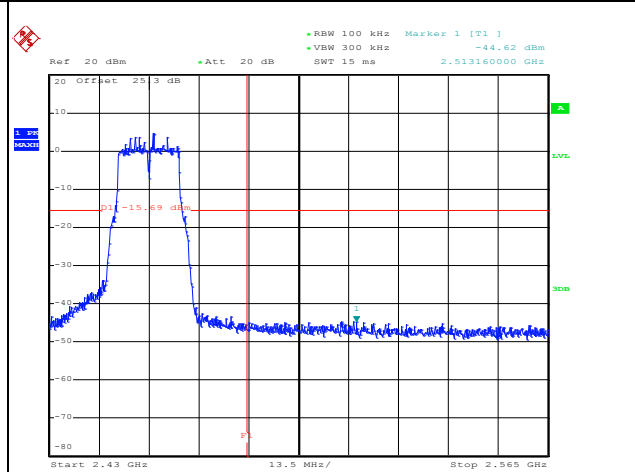

Date: 20.OCT.2017 01:00:45

Spurious Emission 30MHz~3GHz

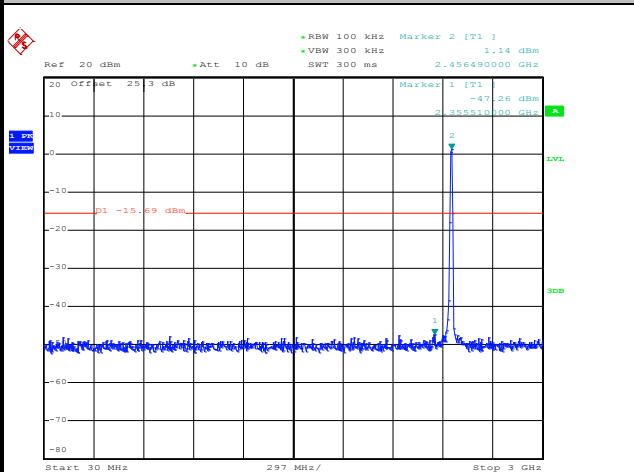

Date: 20.OCT.2017 01:01:01

Spurious Emission 2GHz~25GHz

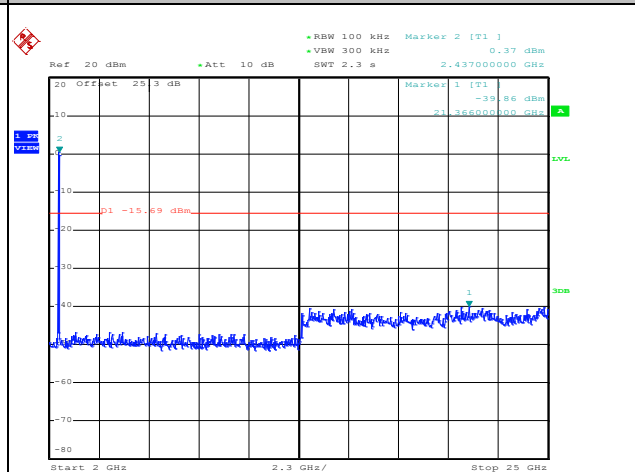

Date: 20.OCT.2017 01:01:10



Number of TX :	2	Ant. :	1
Test Mode :	802.11g	Temperature :	21~25°C
Test Band :	2.4GHz High	Relative Humidity :	51~54%
Test Channel :	11	Test Engineer :	Reece Lin and Aking Chang

WLAN 802.11g Channel 11

100kHz PSD reference Level

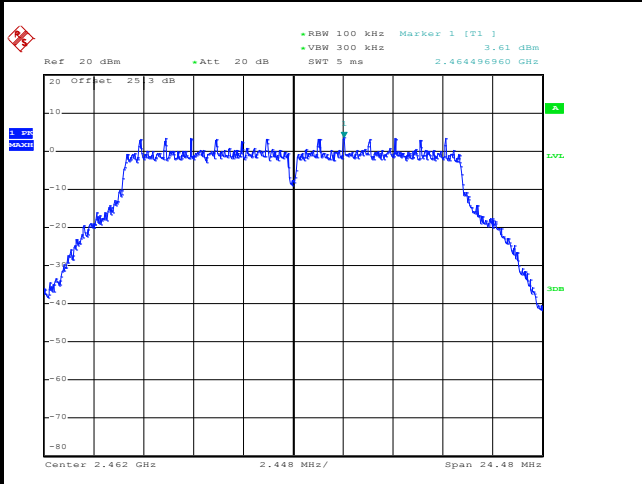

Date: 20.OCT.2017 01:06:37

High Channel Plot

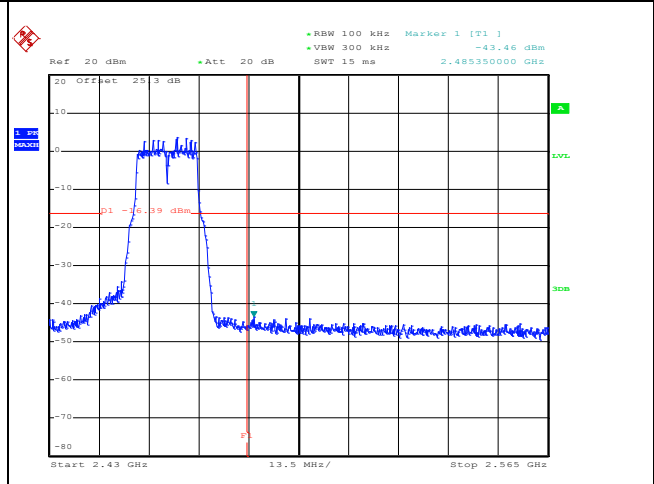

Date: 20.OCT.2017 01:06:54

Spurious Emission 30MHz~3GHz

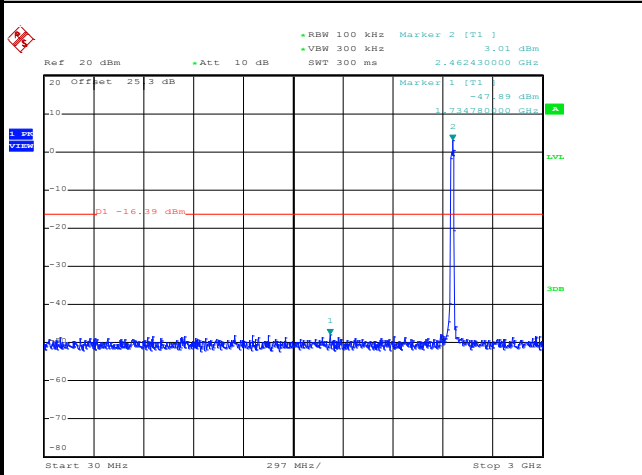

Date: 20.OCT.2017 01:07:05

Spurious Emission 2GHz~25GHz

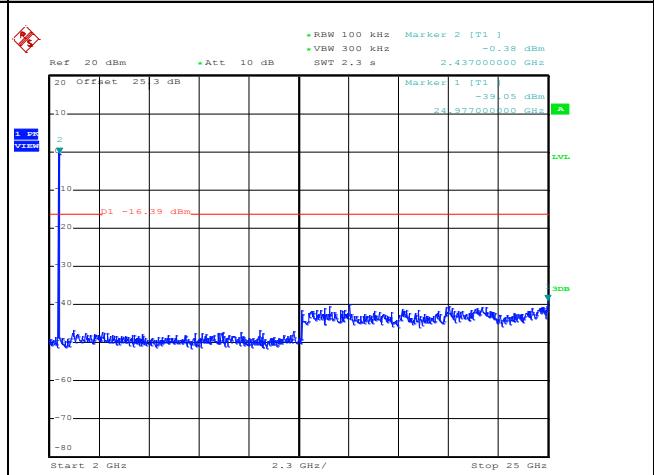

Date: 20.OCT.2017 01:07:13



Number of TX :	2	Ant. :	1
Test Mode :	802.11n HT20	Temperature :	21~25°C
Test Band :	2.4GHz Low	Relative Humidity :	51~54%
Test Channel :	01	Test Engineer :	Reece Lin and Aking Chang

WLAN 802.11n HT20 Channel 01

100kHz PSD reference Level

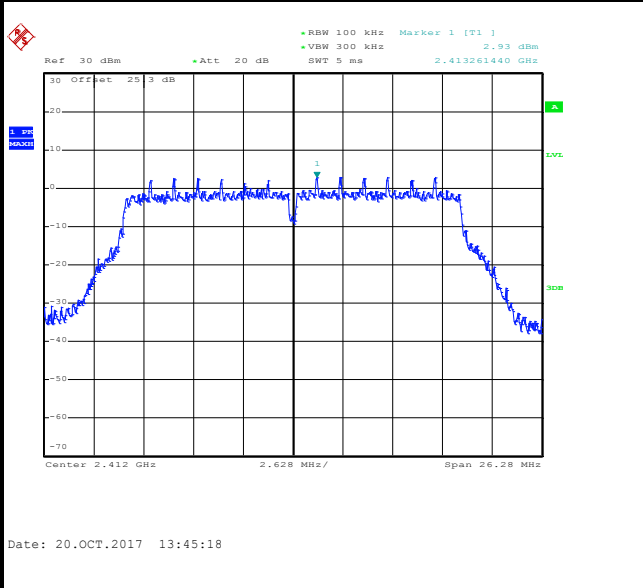

Low Channel Plot

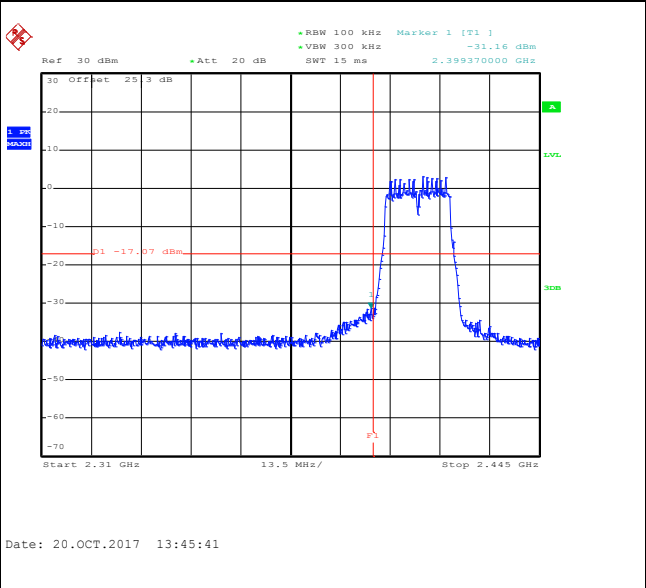

Spurious Emission 30MHz~3GHz

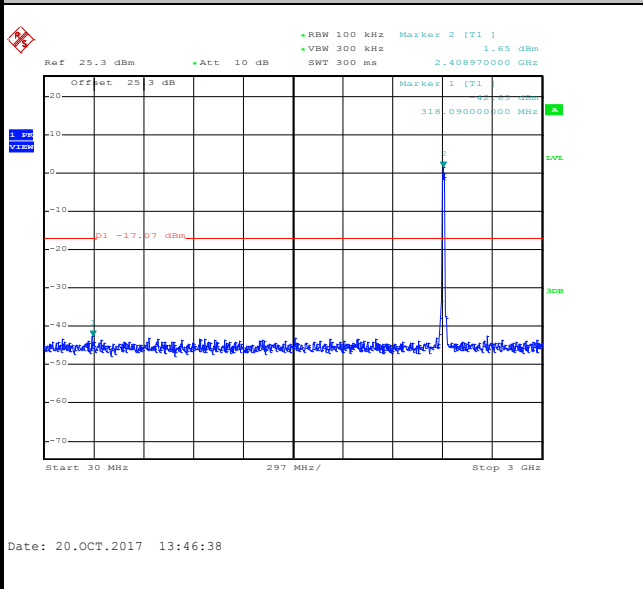

Spurious Emission 2GHz~25GHz

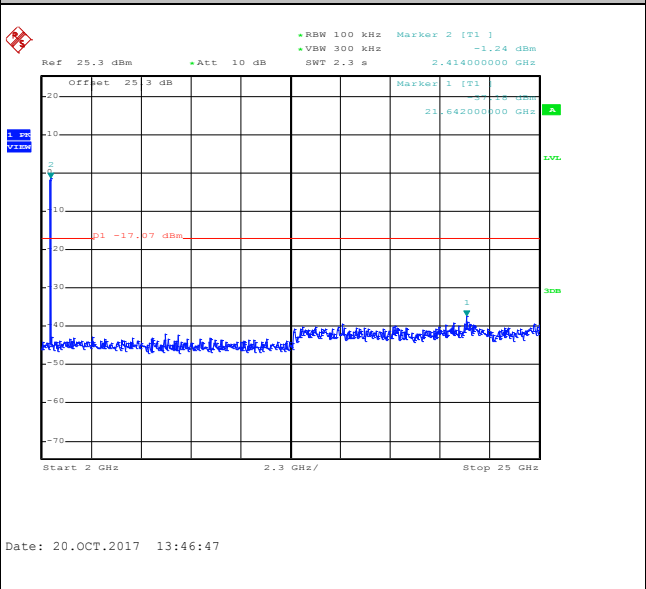



Number of TX :	2	Ant. :	1
Test Mode :	802.11n HT20	Temperature :	21~25°C
Test Band :	2.4GHz Low	Relative Humidity :	51~54%
Test Channel :	02	Test Engineer :	Reece Lin and Aking Chang

WLAN 802.11n HT20 Channel 02

100kHz PSD reference Level

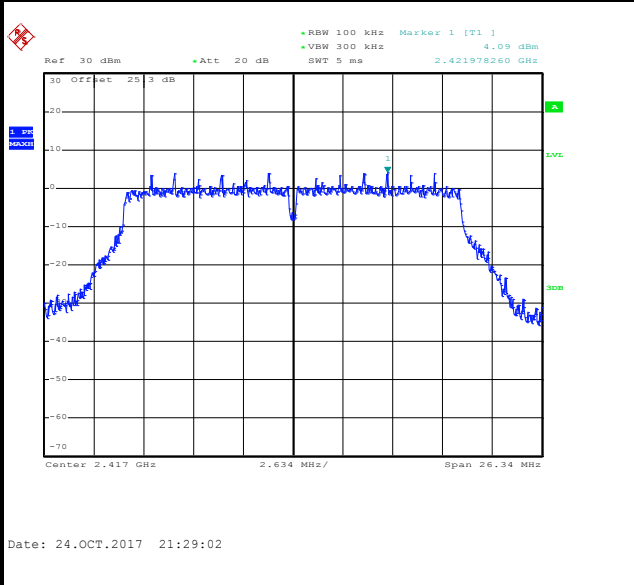

Low Channel Plot

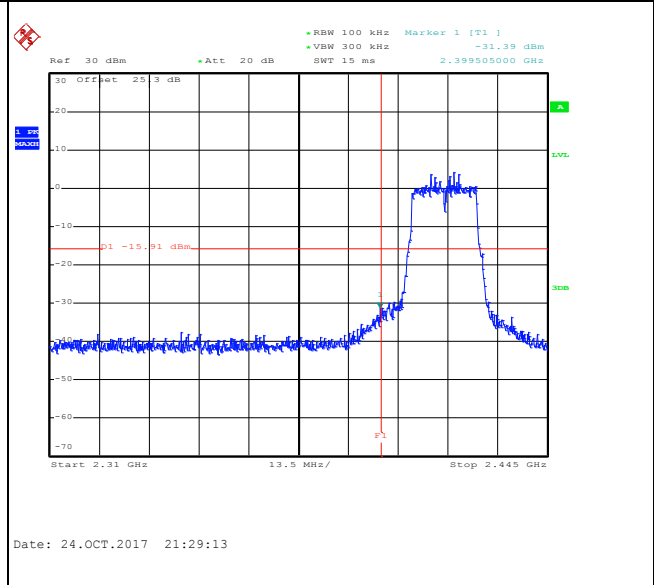

Spurious Emission 30MHz~3GHz

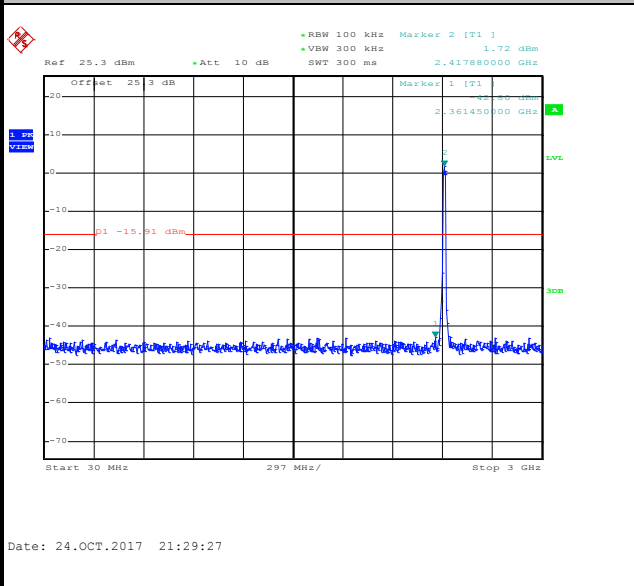

Spurious Emission 2GHz~25GHz

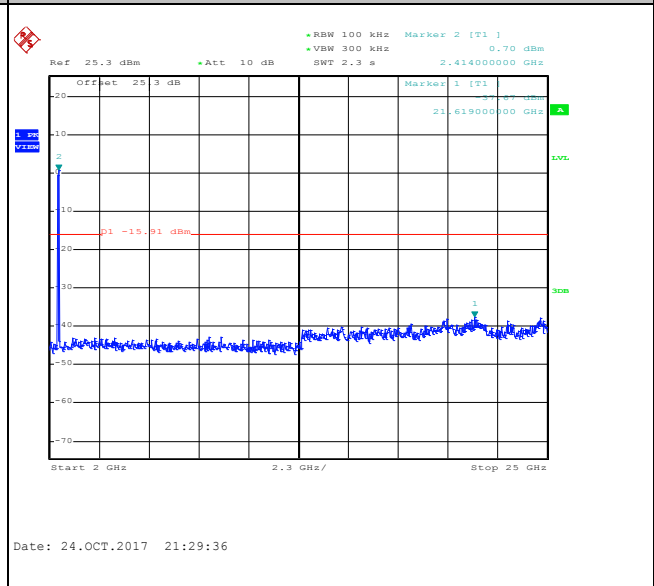



Number of TX :	2	Ant. :	1
Test Mode :	802.11n HT20	Temperature :	21~25°C
Test Band :	2.4GHz Mid	Relative Humidity :	51~54%
Test Channel :	06	Test Engineer :	Reece Lin and Aking Chang

WLAN 802.11n HT20 Channel 06

100kHz PSD reference Level

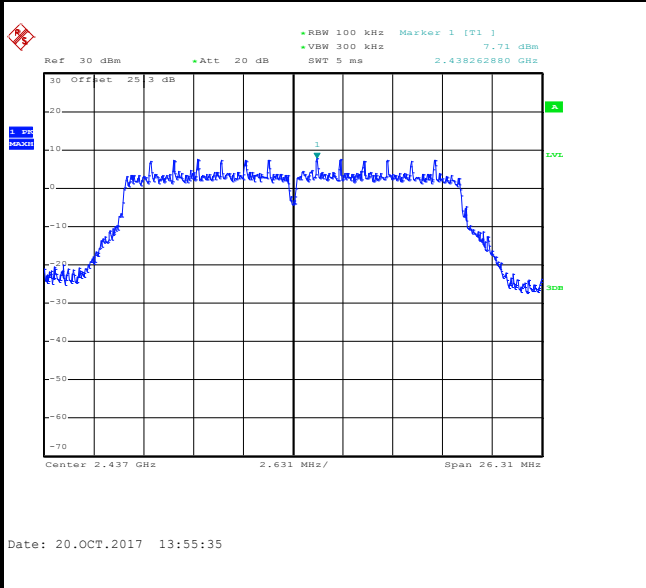

Spurious Emission 30MHz~3GHz

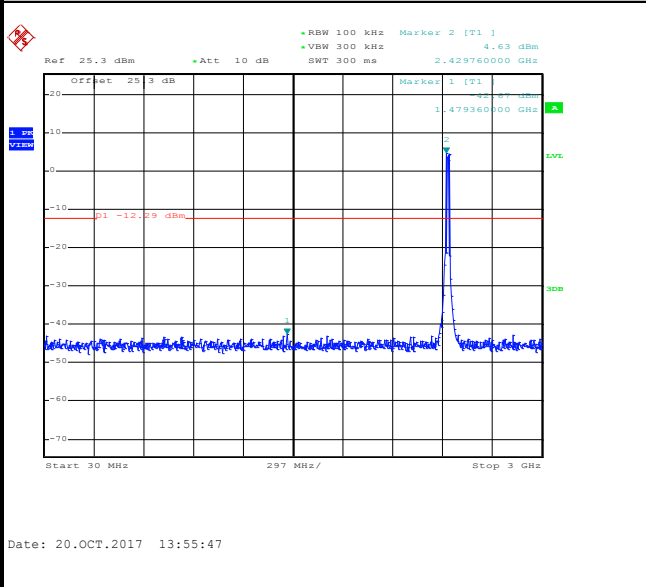

Spurious Emission 2GHz~25GHz

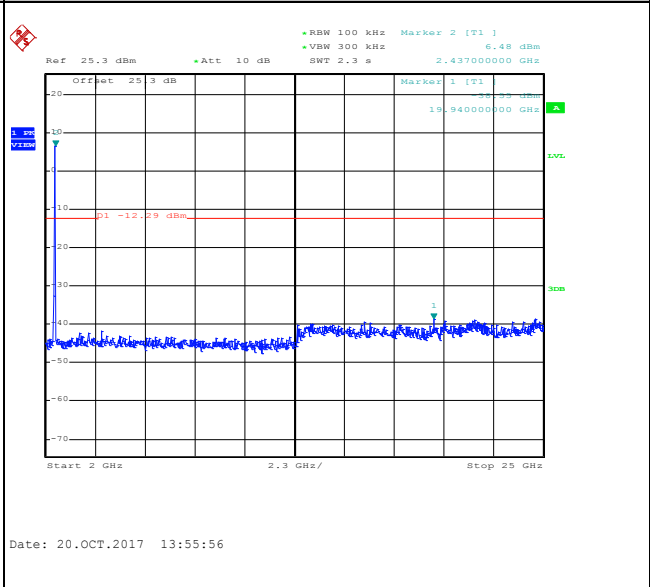



Number of TX :	2	Ant. :	1
Test Mode :	802.11n HT20	Temperature :	21~25°C
Test Band :	2.4GHz High	Relative Humidity :	51~54%
Test Channel :	10	Test Engineer :	Reece Lin and Aking Chang

WLAN 802.11n HT20 Channel 10

100kHz PSD reference Level

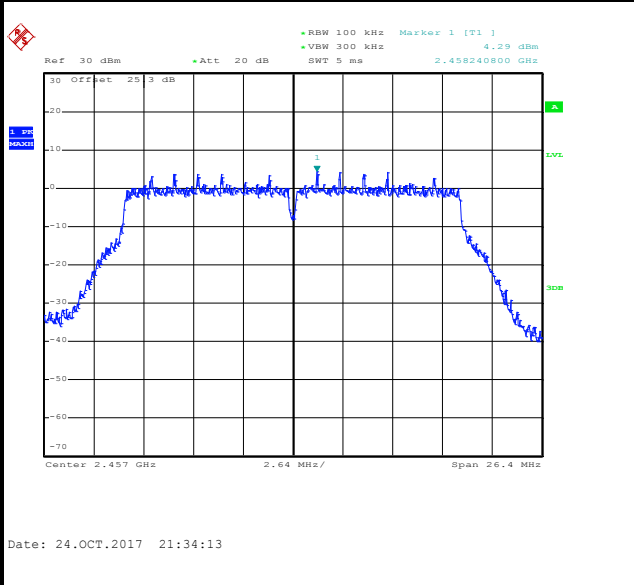

High Channel Plot

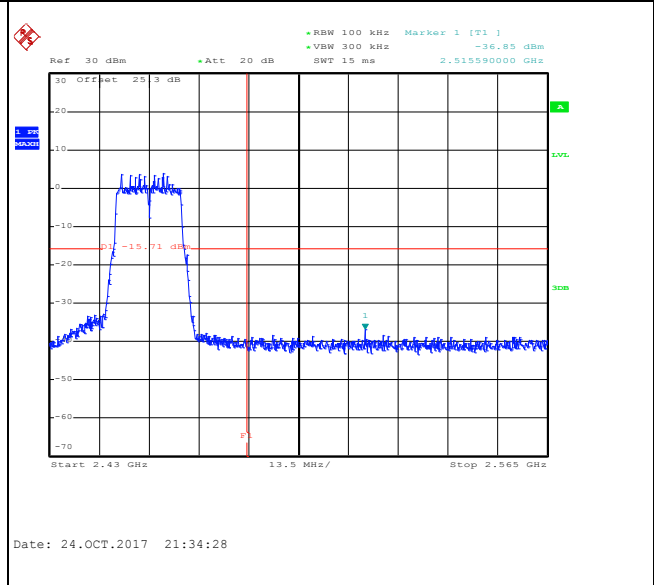

Spurious Emission 30MHz~3GHz

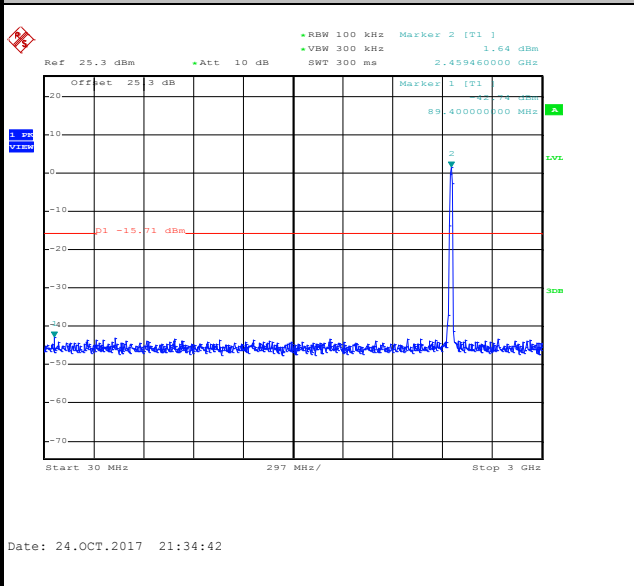

Spurious Emission 2GHz~25GHz

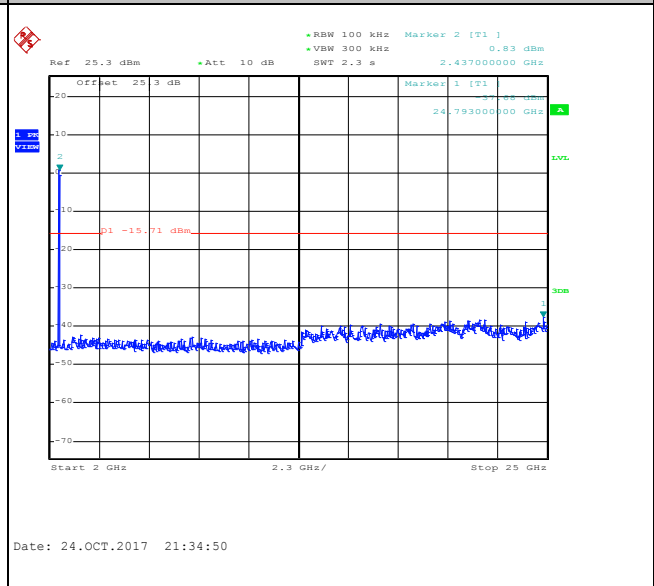



Number of TX :	2	Ant. :	1
Test Mode :	802.11n HT20	Temperature :	21~25°C
Test Band :	2.4GHz High	Relative Humidity :	51~54%
Test Channel :	11	Test Engineer :	Reece Lin and Aking Chang

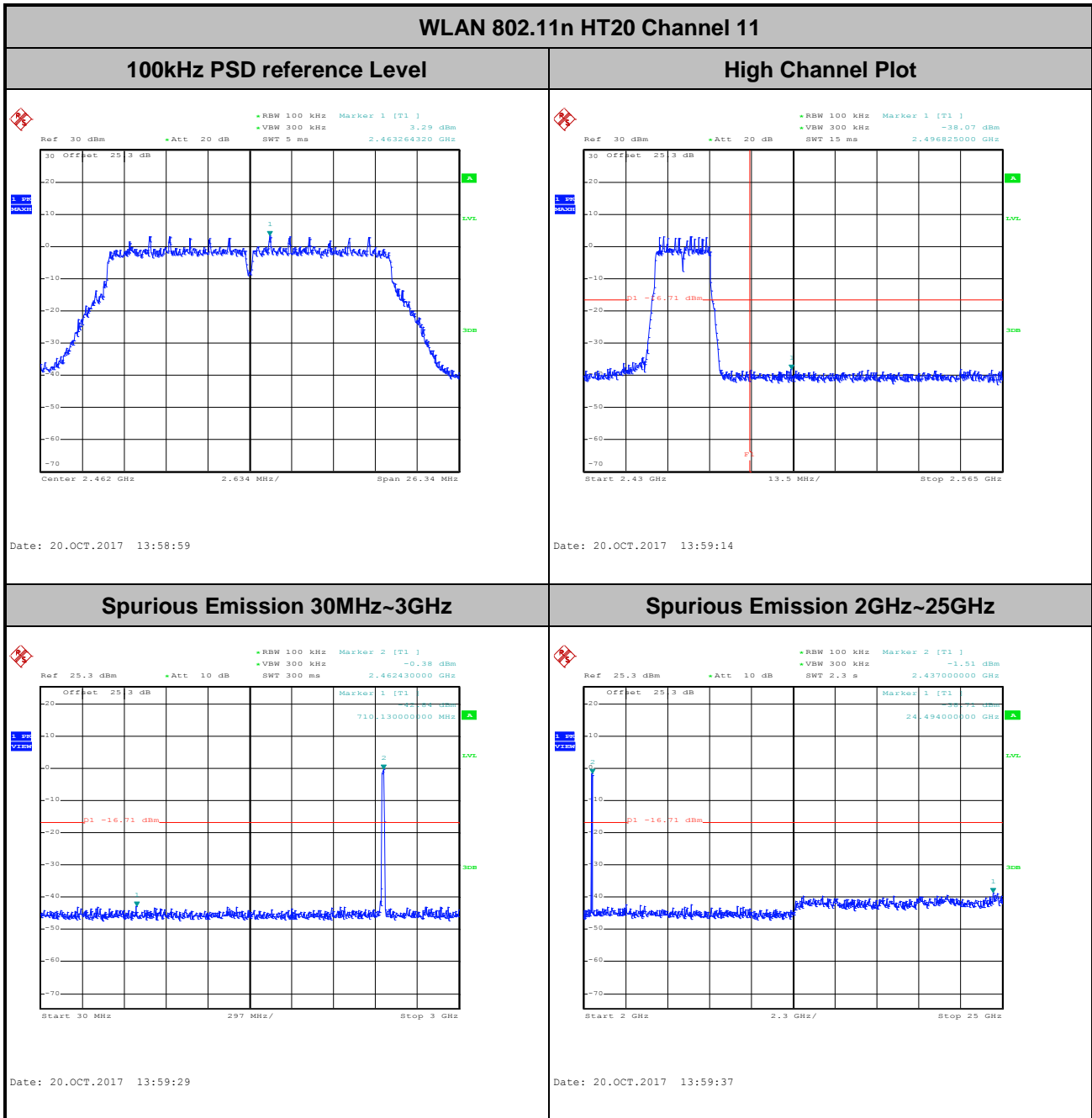



Number of TX = 2, Ant. 2 (Measured)

Number of TX :	2	Ant. :	2
Test Mode :	802.11g	Temperature :	21~25°C
Test Band :	2.4GHz Low	Relative Humidity :	51~54%
Test Channel :	01	Test Engineer :	Reece Lin and Aking Chang

WLAN 802.11g Channel 01

100kHz PSD reference Level

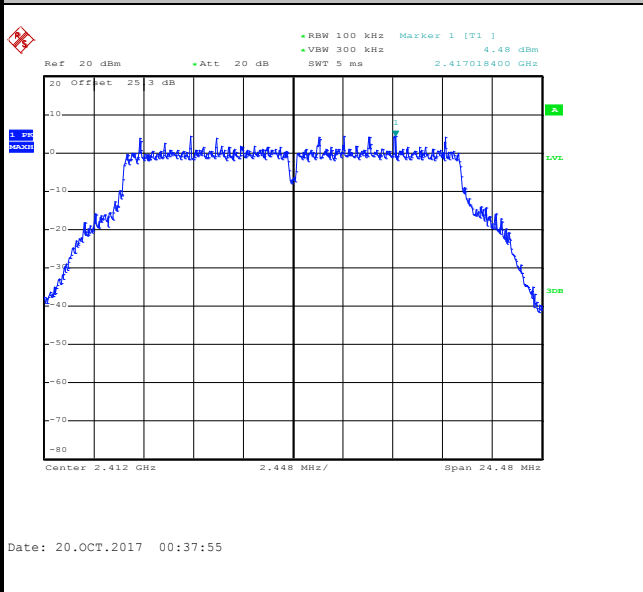

Low Channel Plot

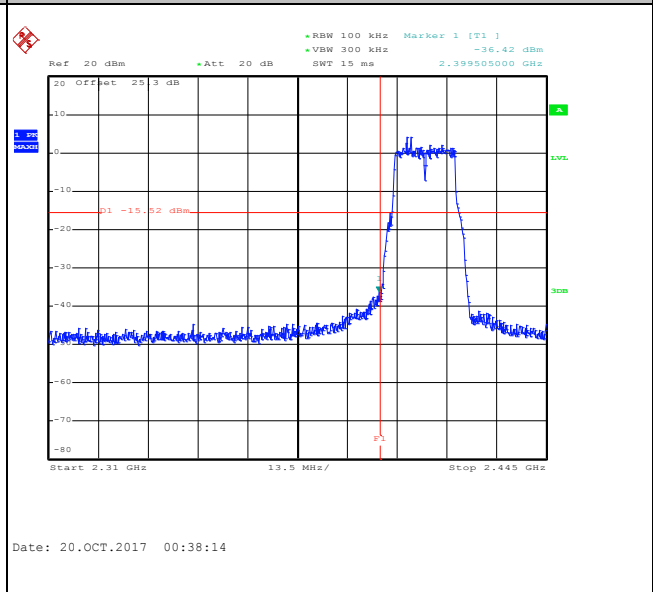

Spurious Emission 30MHz~3GHz

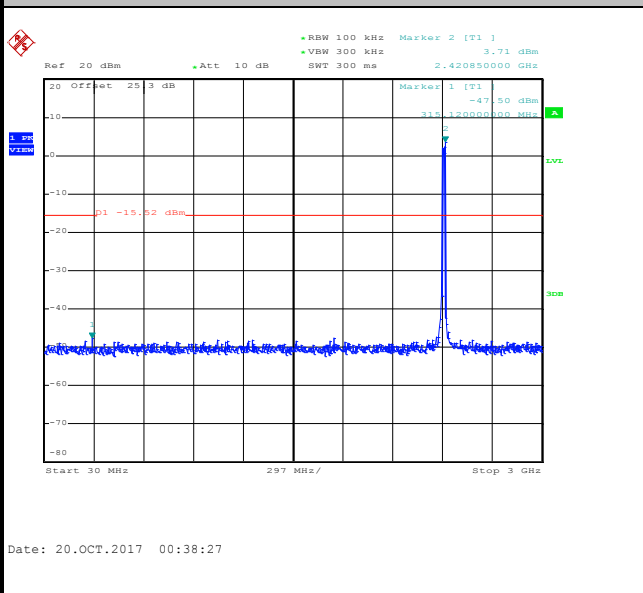

Spurious Emission 2GHz~25GHz

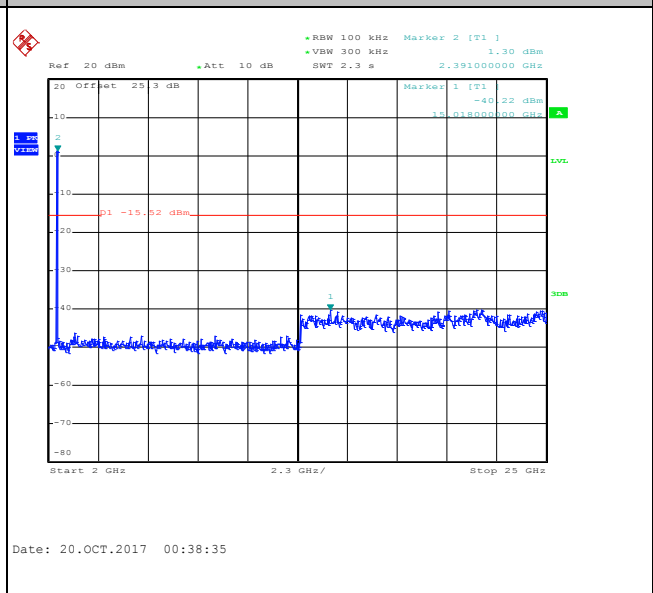



Number of TX :	2	Ant. :	2
Test Mode :	802.11g	Temperature :	21~25°C
Test Band :	2.4GHz Low	Relative Humidity :	51~54%
Test Channel :	02	Test Engineer :	Reece Lin and Aking Chang

WLAN 802.11g Channel 02

100kHz PSD reference Level

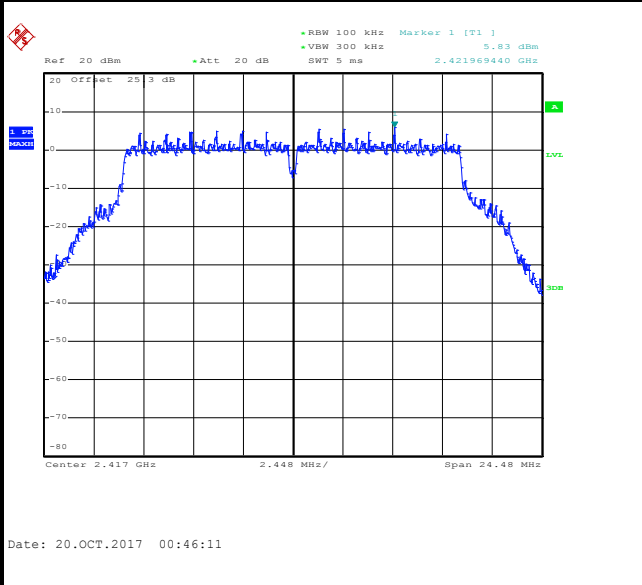

Low Channel Plot

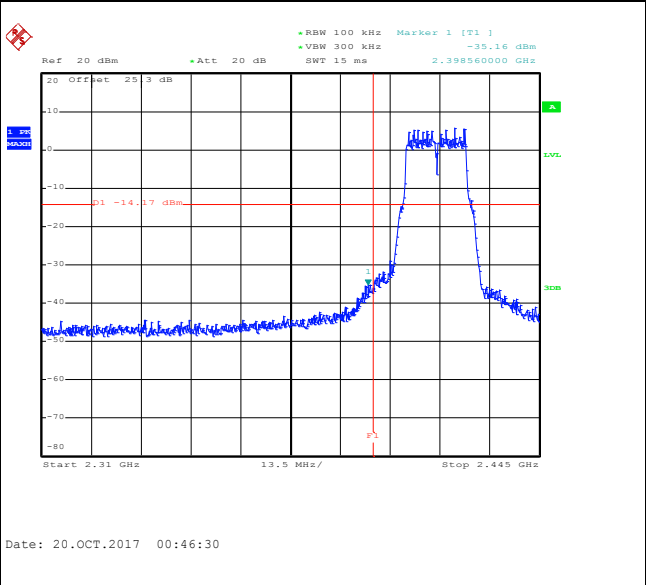

Spurious Emission 30MHz~3GHz

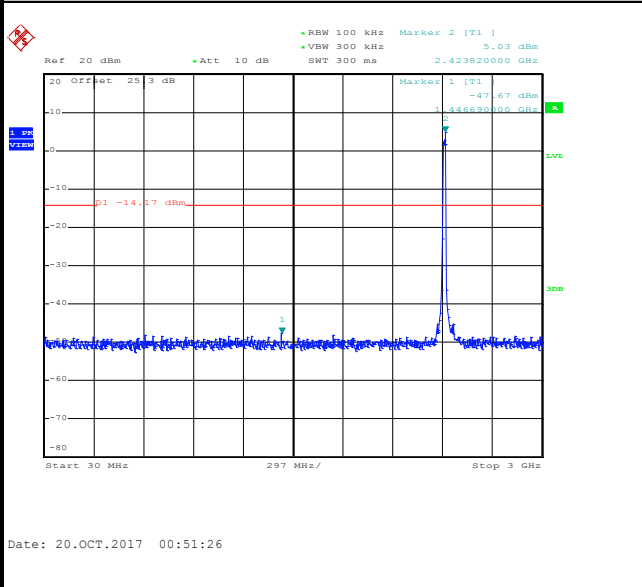

Spurious Emission 2GHz~25GHz

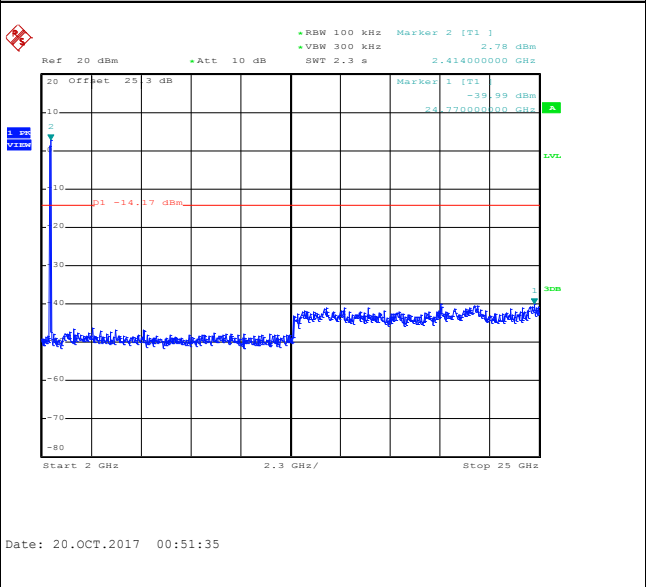



Number of TX :	2	Ant. :	2
Test Mode :	802.11g	Temperature :	21~25°C
Test Band :	2.4GHz Mid	Relative Humidity :	51~54%
Test Channel :	06	Test Engineer :	Reece Lin and Aking Chang

WLAN 802.11g Channel 06

100kHz PSD reference Level

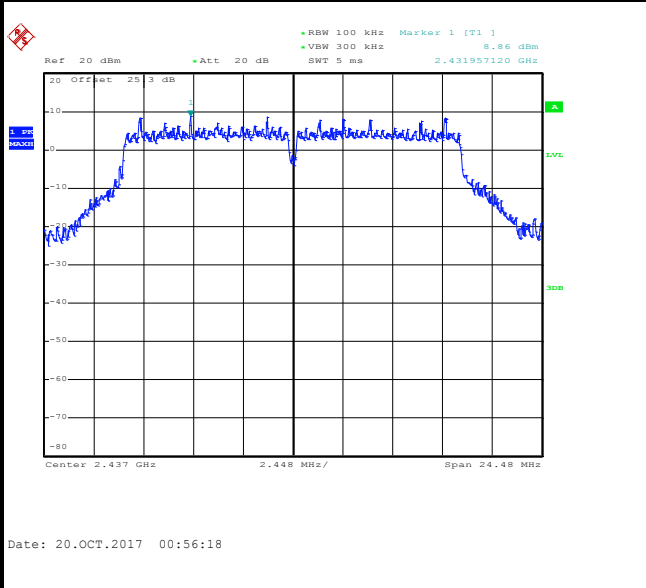

Spurious Emission 30MHz~3GHz

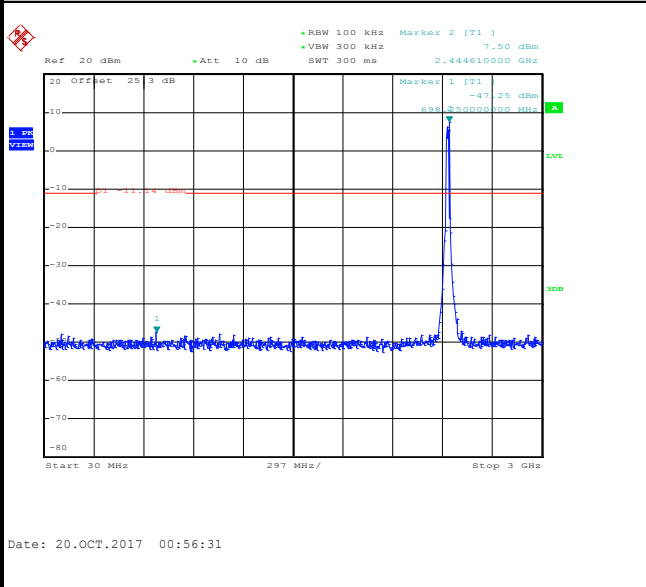

Spurious Emission 2GHz~25GHz

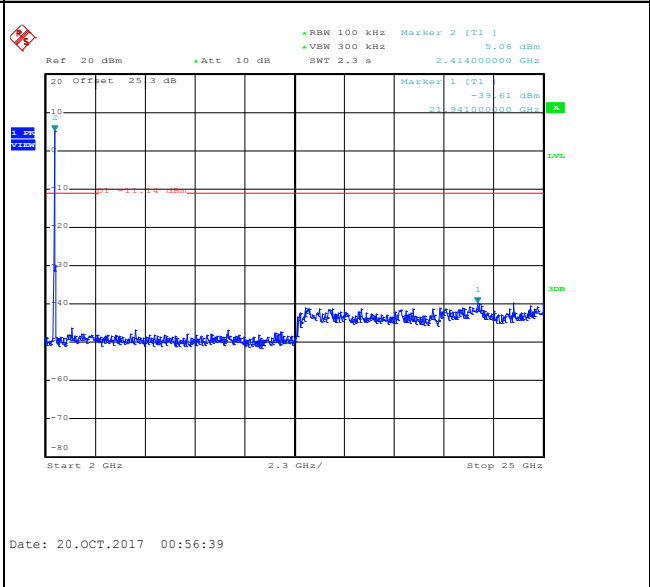



Number of TX :	2	Ant. :	2
Test Mode :	802.11g	Temperature :	21~25°C
Test Band :	2.4GHz High	Relative Humidity :	51~54%
Test Channel :	10	Test Engineer :	Reece Lin and Aking Chang

WLAN 802.11g Channel 10

100kHz PSD reference Level

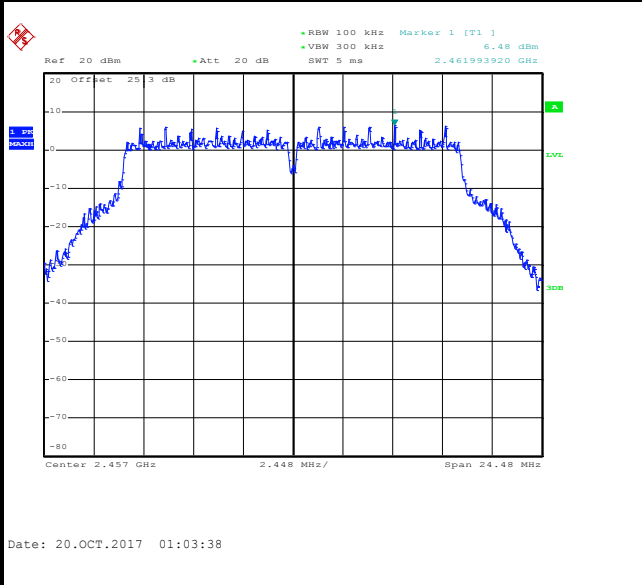

High Channel Plot

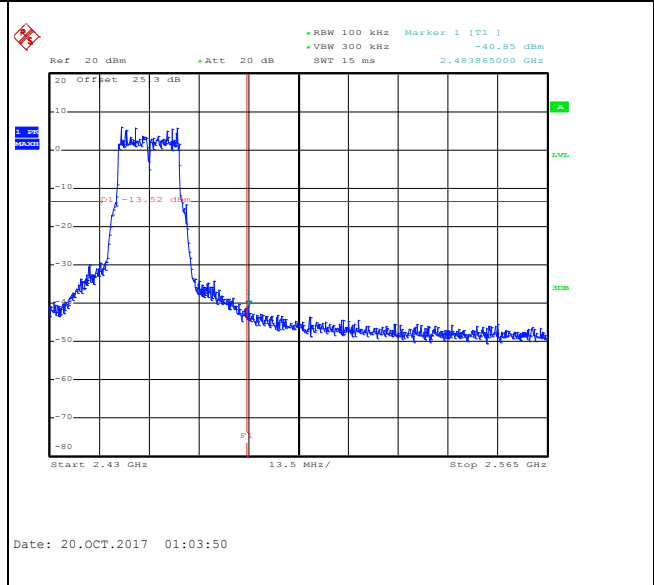

Spurious Emission 30MHz~3GHz

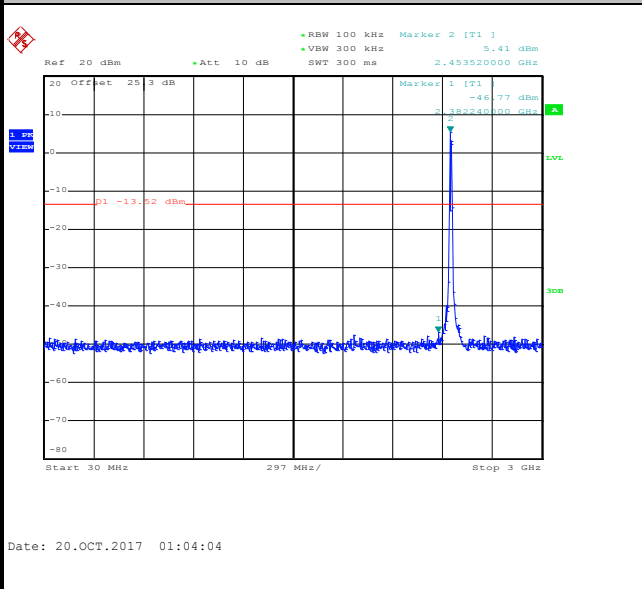

Spurious Emission 2GHz~25GHz

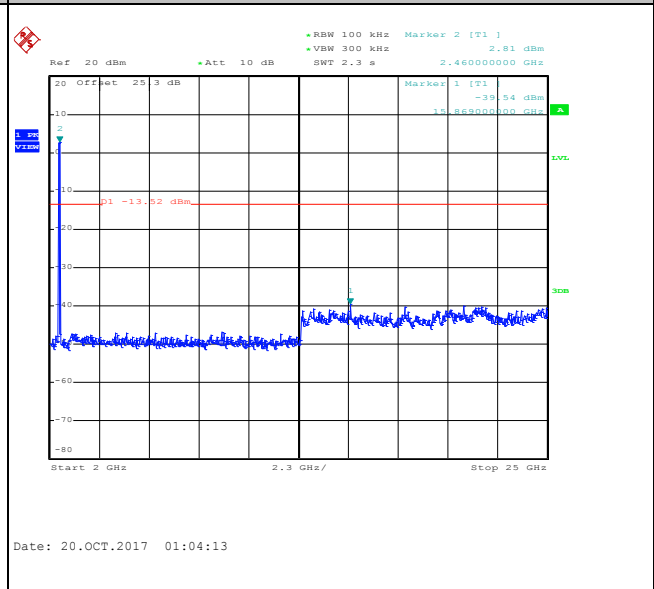



Number of TX :	2	Ant. :	2
Test Mode :	802.11g	Temperature :	21~25°C
Test Band :	2.4GHz High	Relative Humidity :	51~54%
Test Channel :	11	Test Engineer :	Reece Lin and Aking Chang

WLAN 802.11g Channel 11

100kHz PSD reference Level

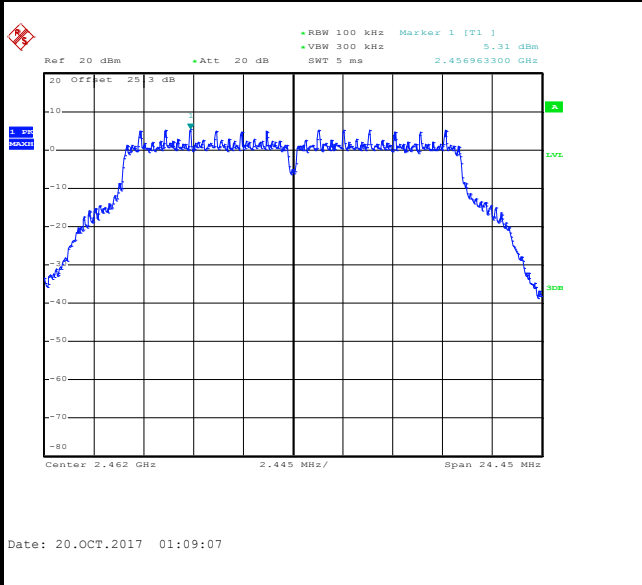

High Channel Plot

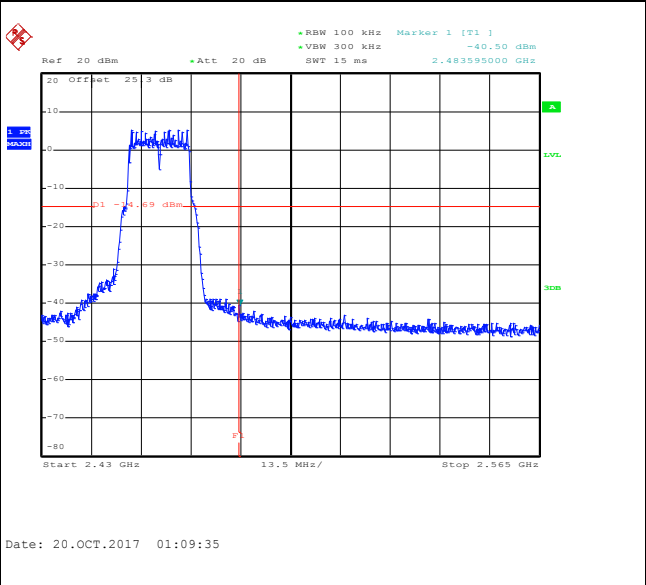

Spurious Emission 30MHz~3GHz

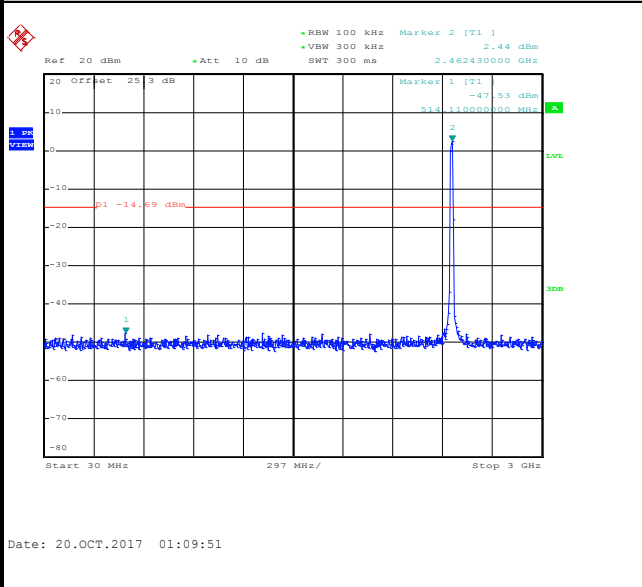

Spurious Emission 2GHz~25GHz

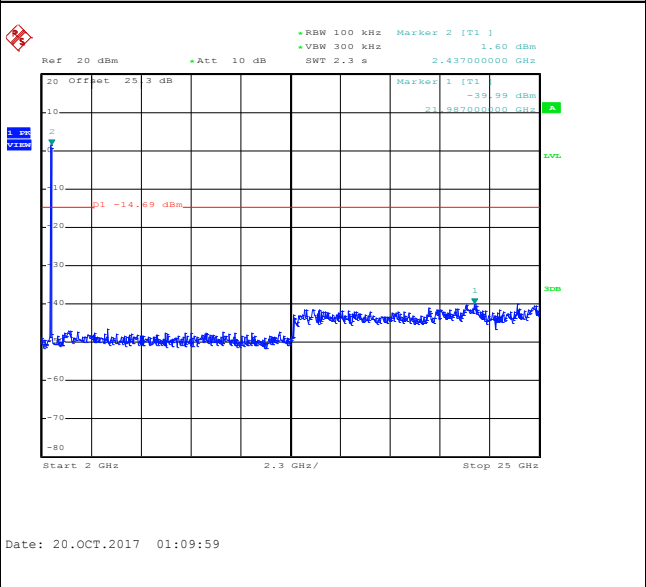



Number of TX :	2	Ant. :	2
Test Mode :	802.11n HT20	Temperature :	21~25°C
Test Band :	2.4GHz Low	Relative Humidity :	51~54%
Test Channel :	01	Test Engineer :	Reece Lin and Aking Chang

WLAN 802.11n HT20 Channel 01

100kHz PSD reference Level

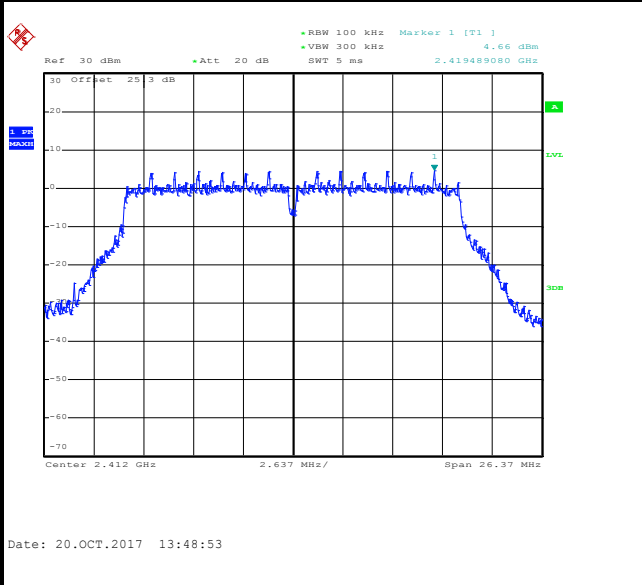

Low Channel Plot

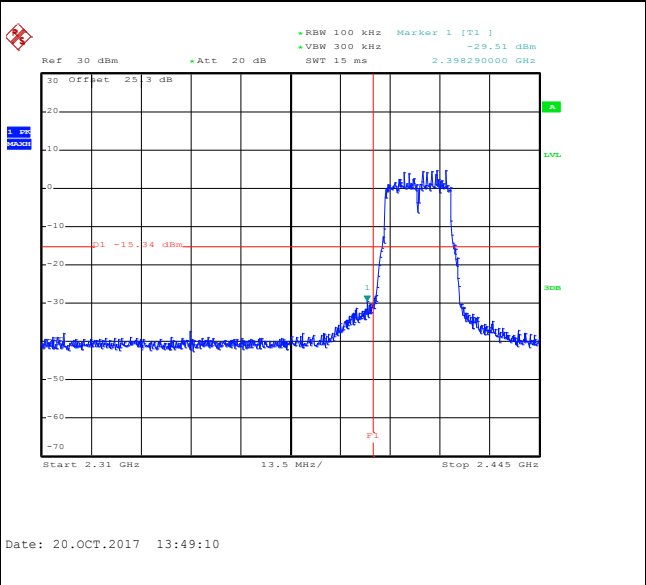

Spurious Emission 30MHz~3GHz

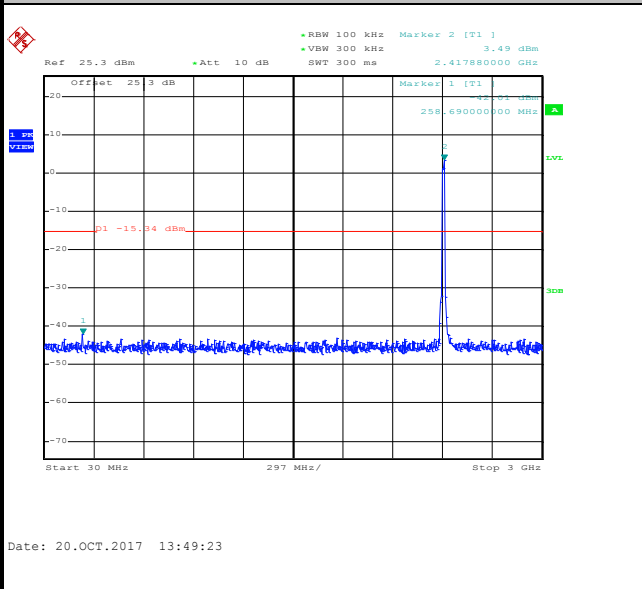

Spurious Emission 2GHz~25GHz

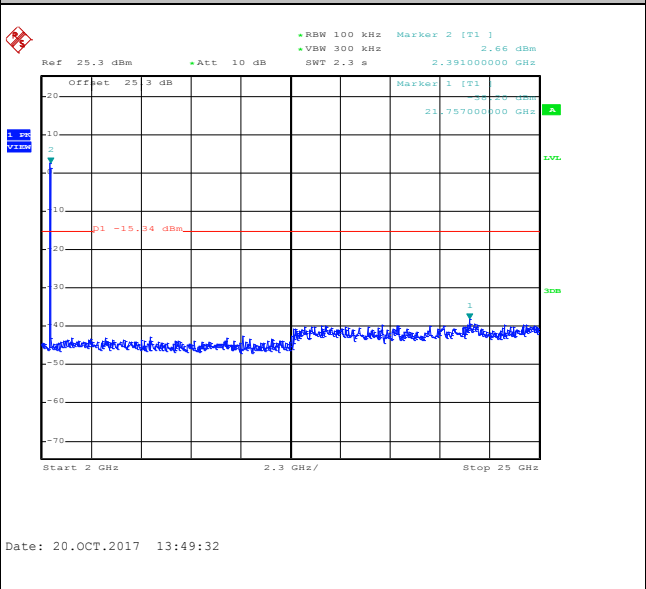



Number of TX :	2	Ant. :	2
Test Mode :	802.11n HT20	Temperature :	21~25°C
Test Band :	2.4GHz Low	Relative Humidity :	51~54%
Test Channel :	02	Test Engineer :	Reece Lin and Aking Chang

WLAN 802.11n HT20 Channel 02

100kHz PSD reference Level

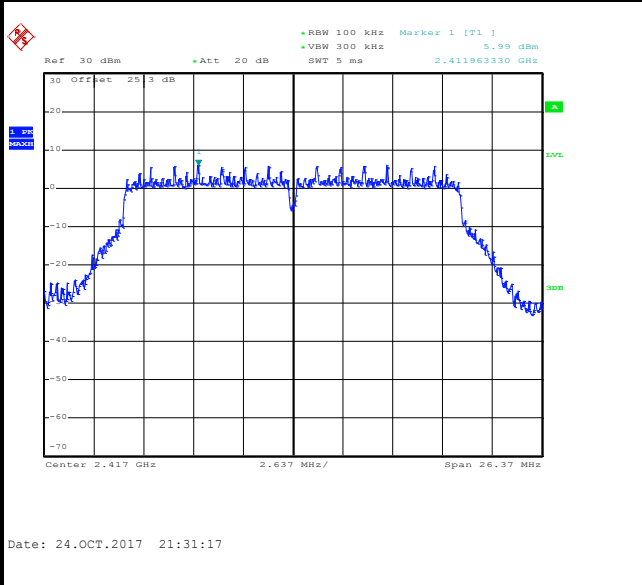

Low Channel Plot

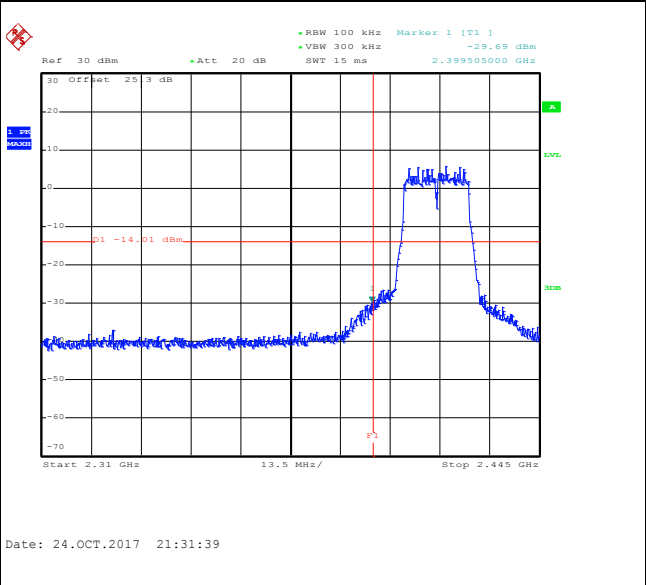

Spurious Emission 30MHz~3GHz

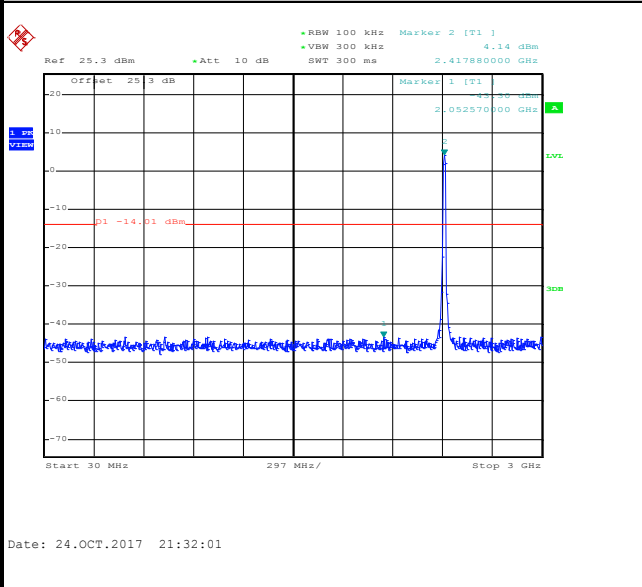

Spurious Emission 2GHz~25GHz

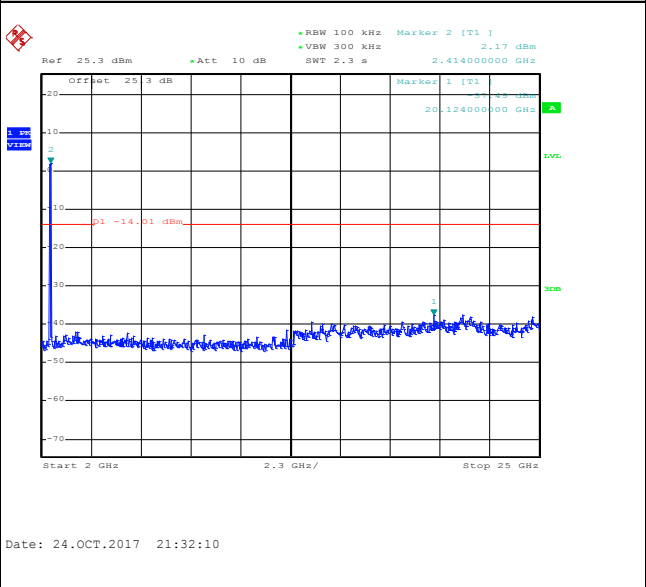



Number of TX :	2	Ant. :	2
Test Mode :	802.11n HT20	Temperature :	21~25°C
Test Band :	2.4GHz Mid	Relative Humidity :	51~54%
Test Channel :	06	Test Engineer :	Reece Lin and Aking Chang

WLAN 802.11n HT20 Channel 06

100kHz PSD reference Level

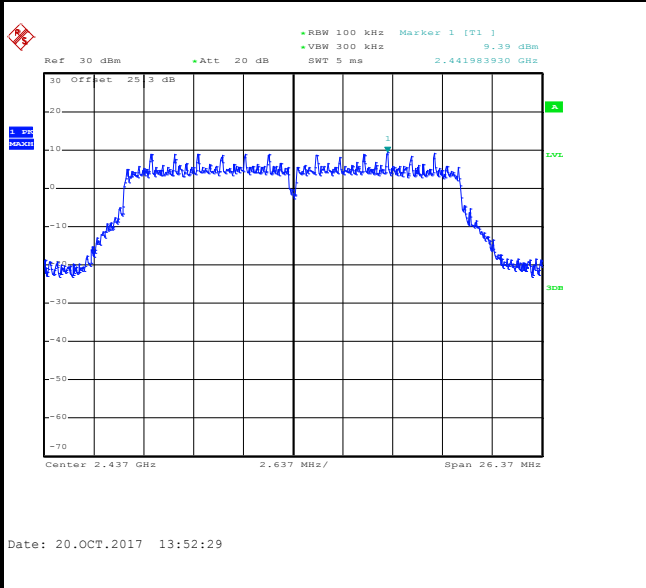

Spurious Emission 30MHz~3GHz

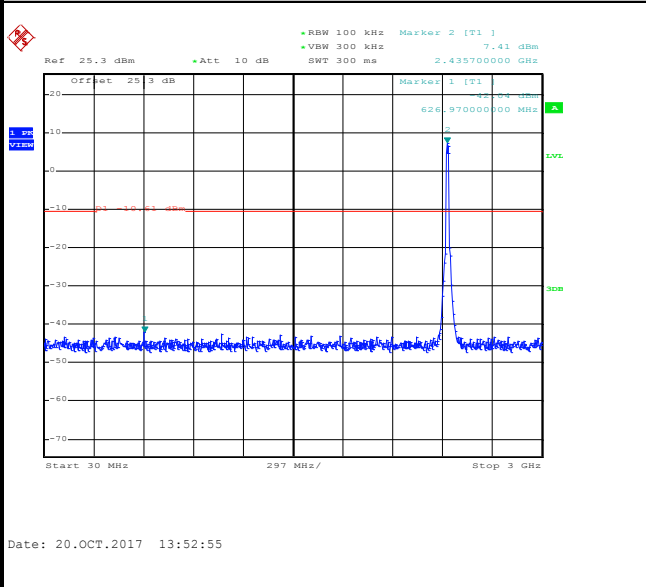

Spurious Emission 2GHz~25GHz

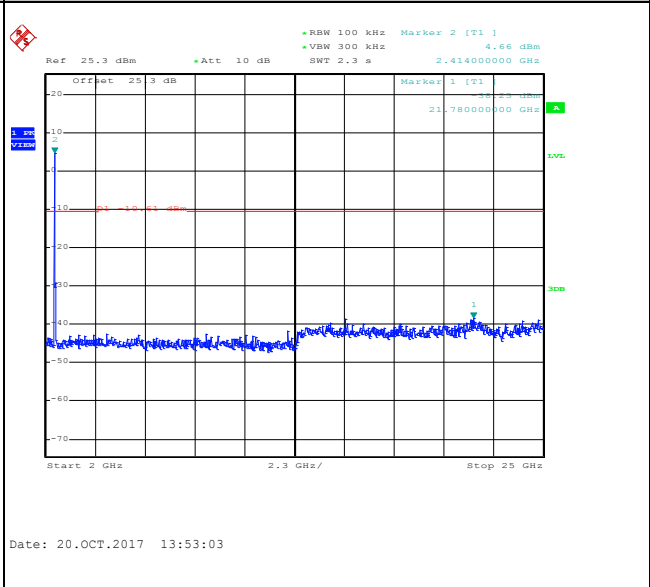



Number of TX :	2	Ant. :	2
Test Mode :	802.11n HT20	Temperature :	21~25°C
Test Band :	2.4GHz High	Relative Humidity :	51~54%
Test Channel :	10	Test Engineer :	Reece Lin and Aking Chang

WLAN 802.11n HT20 Channel 10

100kHz PSD reference Level

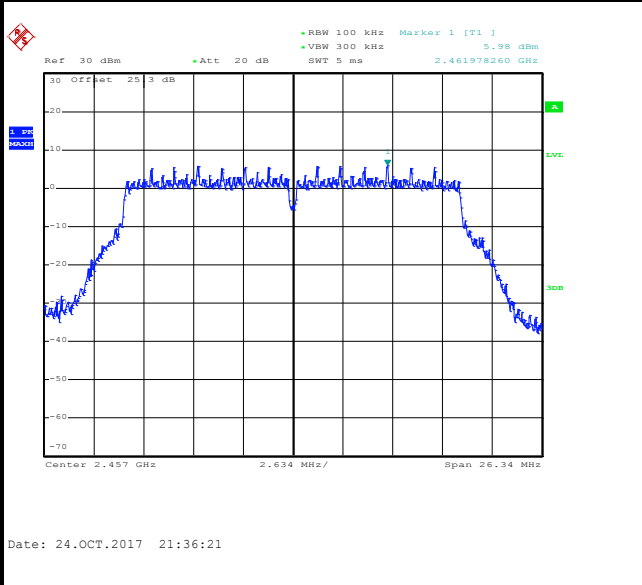

High Channel Plot

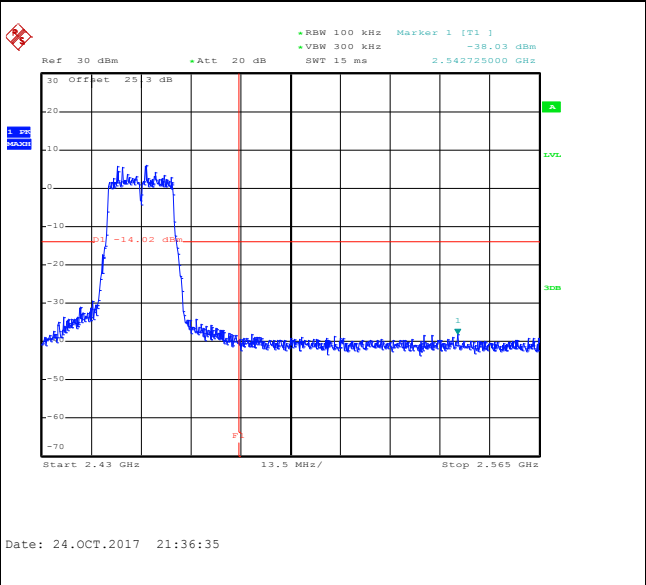

Spurious Emission 30MHz~3GHz

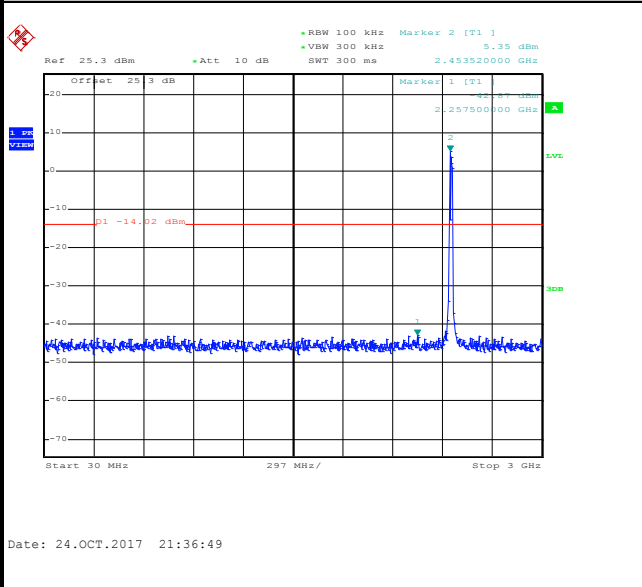

Spurious Emission 2GHz~25GHz

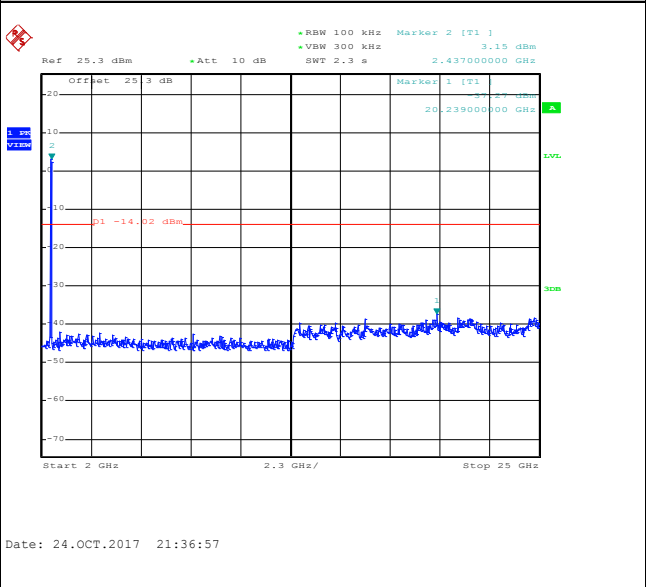



Number of TX :	2	Ant. :	2
Test Mode :	802.11n HT20	Temperature :	21~25°C
Test Band :	2.4GHz High	Relative Humidity :	51~54%
Test Channel :	11	Test Engineer :	Reece Lin and Aking Chang

WLAN 802.11n HT20 Channel 11

100kHz PSD reference Level

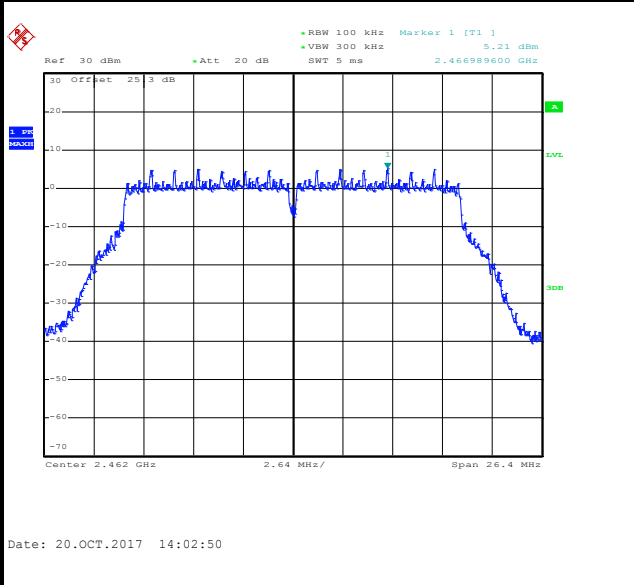

High Channel Plot

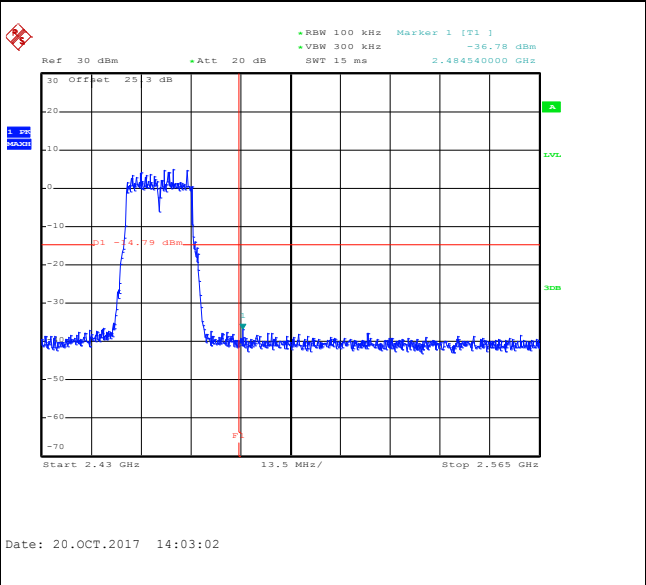

Spurious Emission 30MHz~3GHz

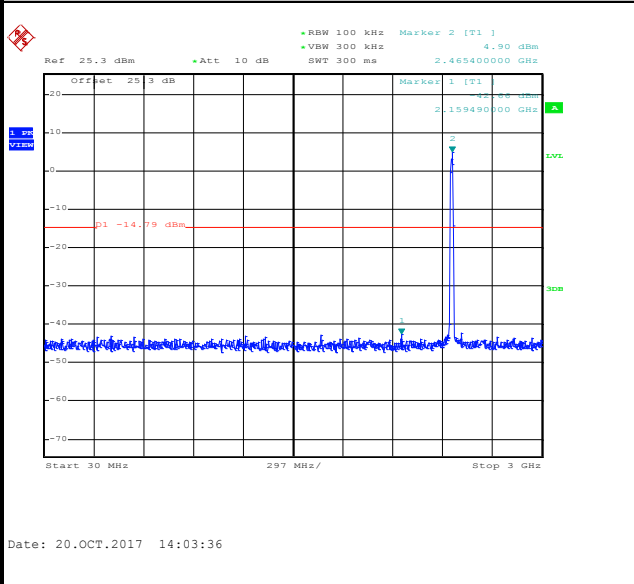

Spurious Emission 2GHz~25GHz

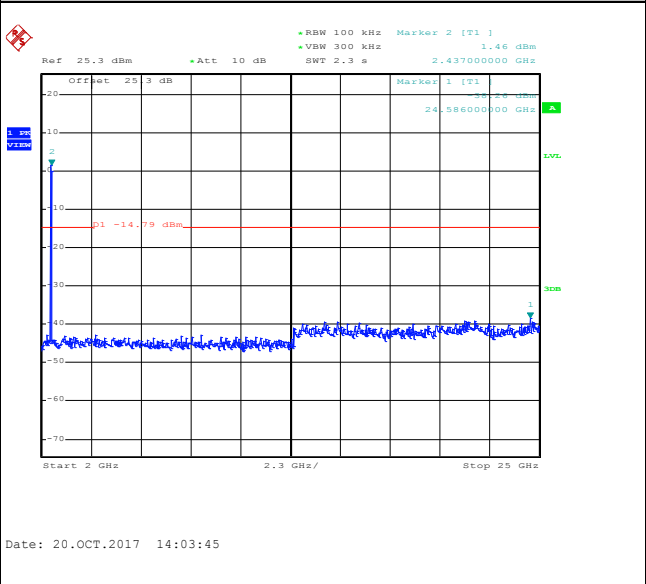



3.5 Radiated Band Edges and Spurious Emission Measurement

3.5.1 Limit of Radiated band edge and Spurious Emission Measurement

In any 100 kHz bandwidth outside the intentional radiator frequency band, all harmonics/spurious must be at least 20 dB below the highest emission level within the authorized band. If the output power of this device was measured by spectrum analyzer, the attenuation under this paragraph shall be 30 dB instead of 20 dB. In addition, radiated emissions which fall in the restricted bands must also comply with the limits as below.

Frequency (MHz)	Field Strength (microvolts/meter)	Measurement Distance (meters)
0.009 – 0.490	2400/F(kHz)	300
0.490 – 1.705	24000/F(kHz)	30
1.705 – 30.0	30	30
30 – 88	100	3
88 – 216	150	3
216 - 960	200	3
Above 960	500	3

3.5.2 Measuring Instruments

The measuring equipment is listed in the section 4 of this test report.



3.5.3 Test Procedures

1. The testing follows FCC KDB Publication No. 558074 D01 DTS Meas. Guidance v04.
2. The EUT was arranged to its worst case and then tune the antenna tower (from 1 m to 4 m) and turntable (from 0 degree to 360 degrees) to find the maximum reading. A pre-amp and a high pass filter are used for the test in order to get better signal level.
3. The EUT was placed on a turntable with 0.8 meter for frequency below 1GHz and 1.5 meter for frequency above 1GHz respectively above ground.
4. The EUT was set 3 meters from the interference receiving antenna, which was mounted on the top of a variable height antenna tower.
5. Corrected Reading: Antenna Factor + Cable Loss + Read Level - Preamp Factor = Level
6. For measurement below 1GHz, If the emission level of the EUT measured by the peak detector is 3 dB lower than the applicable limit, the peak emission level will be reported. Otherwise, the emission measurement will be repeated using the quasi-peak detector and reported.
7. Use the following spectrum analyzer settings:
 - (1) Span shall wide enough to fully capture the emission being measured;
 - (2) Set RBW=100 kHz for $f < 1$ GHz; VBW \geq RBW; Sweep = auto; Detector function = peak; Trace = max hold;
 - (3) Set RBW = 1 MHz, VBW= 3MHz for $f \geq 1$ GHz for peak measurement.
For average measurement:
 - VBW = 10 Hz, when duty cycle is no less than 98 percent.
 - VBW $\geq 1/T$, when duty cycle is less than 98 percent where T is the minimum transmission duration over which the transmitter is on and is transmitting at its maximum power control level for the tested mode of operation.

3.5.4 Test Setup

For radiated emissions below 30MHz

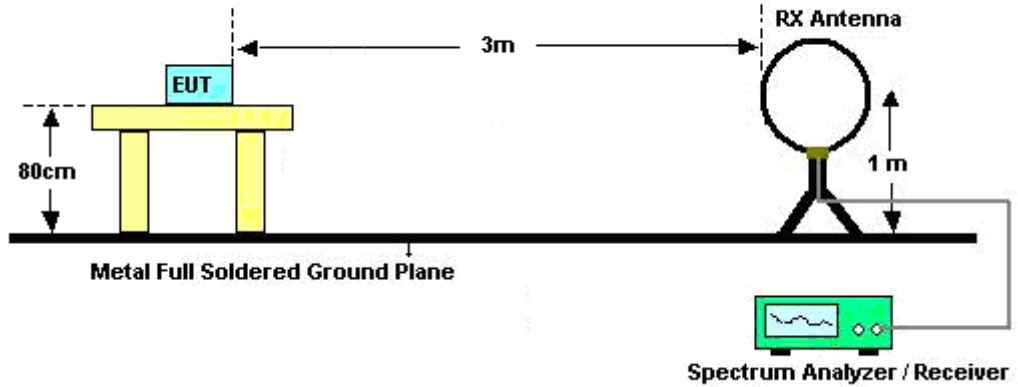

For radiated emissions from 30MHz to 1GHz

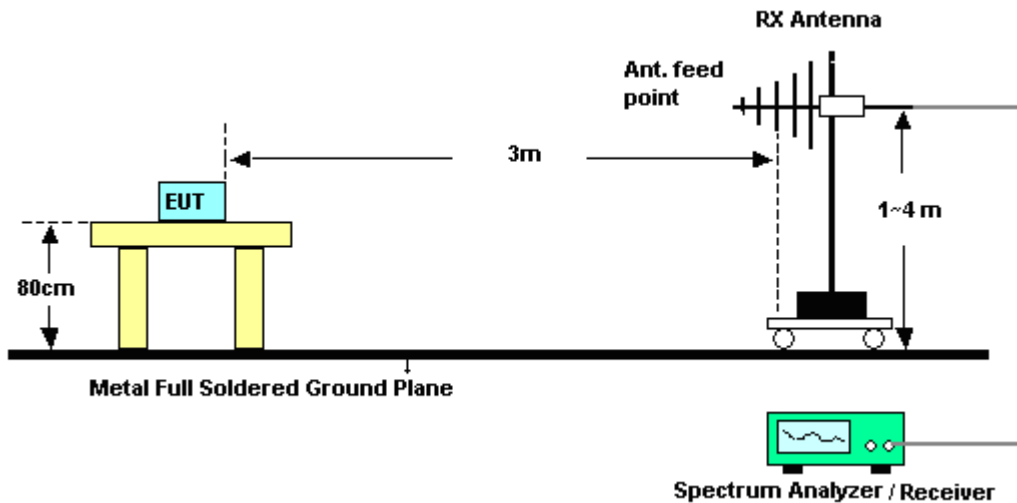

For radiated emissions above 1GHz

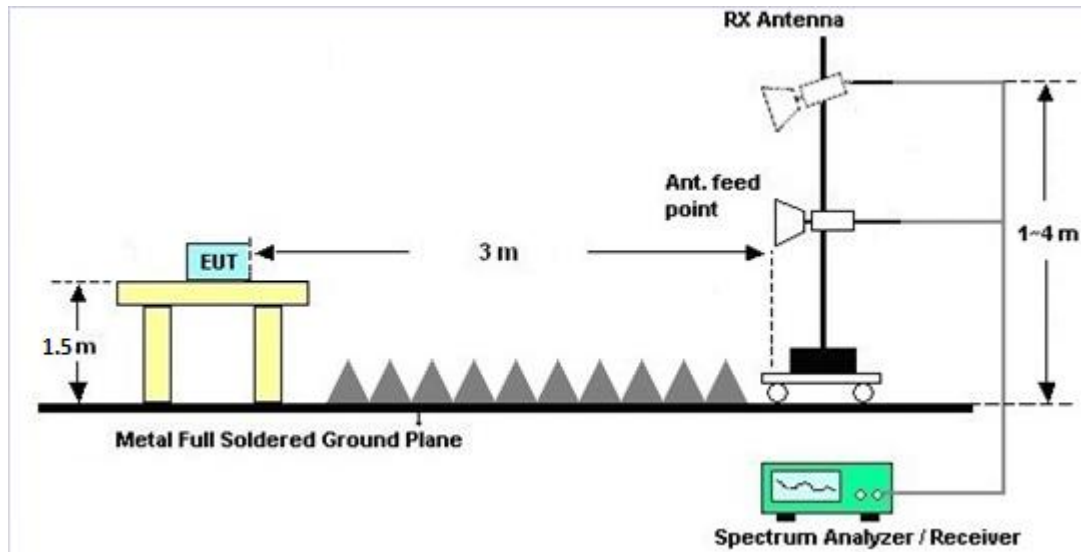

3.5.5 Test Results of Radiated Spurious Emissions (9kHz ~ 30MHz)

The low frequency, which started from 9 kHz to 30MHz, was pre-scanned and the result which was 20dB lower than the limit line was not reported.

There is a comparison data of both open-field test site and semi-Anechoic chamber, and the result came out very similar.

3.5.6 Test Result of Radiated Spurious at Band Edges

Please refer to Appendix B and C.

3.5.7 Duty Cycle

Please refer to Appendix D.

3.5.8 Test Result of Radiated Spurious Emission (30MHz ~ 10th Harmonic)

Please refer to Appendix B and C.



3.6 AC Conducted Emission Measurement

3.6.1 Limit of AC Conducted Emission

For equipment that is designed to be connected to the public utility (AC) power line, the radio frequency voltage that is conducted back onto the AC power line on any frequency or frequencies within the band 150 kHz to 30 MHz shall not exceed the limits in the following table.

Frequency of Emission (MHz)	Conducted Limit (dB μ V)	
	Quasi-Peak	Average
0.15-0.5	66 to 56*	56 to 46*
0.5-5	56	46
5-30	60	50

*Decreases with the logarithm of the frequency.

3.6.2 Measuring Instruments

The measuring equipment is listed in the section 4 of this test report.

3.6.3 Test Procedures

1. The EUT was placed 0.4 meter from the conducting wall of the shielding room, and it was kept at least 80 centimeters from any other grounded conducting surface.
2. Connect EUT to the power mains through a line impedance stabilization network (LISN).
3. All the support units are connecting to the other LISN.
4. The LISN provides 50 ohm coupling impedance for the measuring instrument.
5. The FCC states that a 50 ohm, 50 microhenry LISN should be used.
6. Both sides of AC line were checked for maximum conducted interference.
7. The frequency range from 150 kHz to 30 MHz was searched.
8. Set the test-receiver system to Peak Detect Function and specified bandwidth (IF bandwidth = 9kHz) with Maximum Hold Mode.

3.6.4 Test Setup

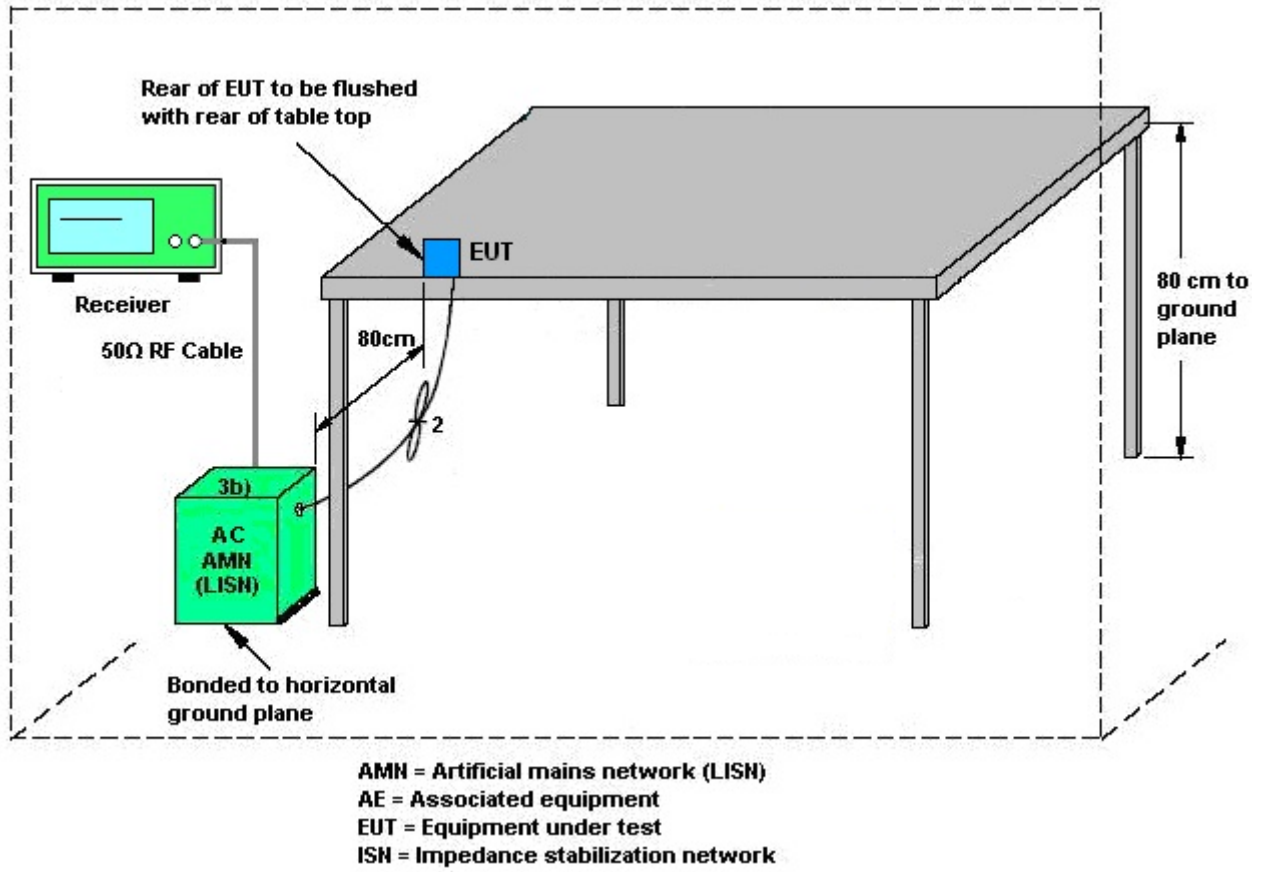

3.6.5 Test Result of AC Conducted Emission

Test Mode :	Mode 1	Temperature :	22~25°C
Test Engineer :	Kai-Chun Chu	Relative Humidity :	52~55%
Test Voltage :	120Vac / 60Hz	Phase :	Line
Function Type :	WLAN On + BLE On + Zigbee On + Sensor On + LED On + IR LED On + Speaker On + Camera + AC to AC transformer		

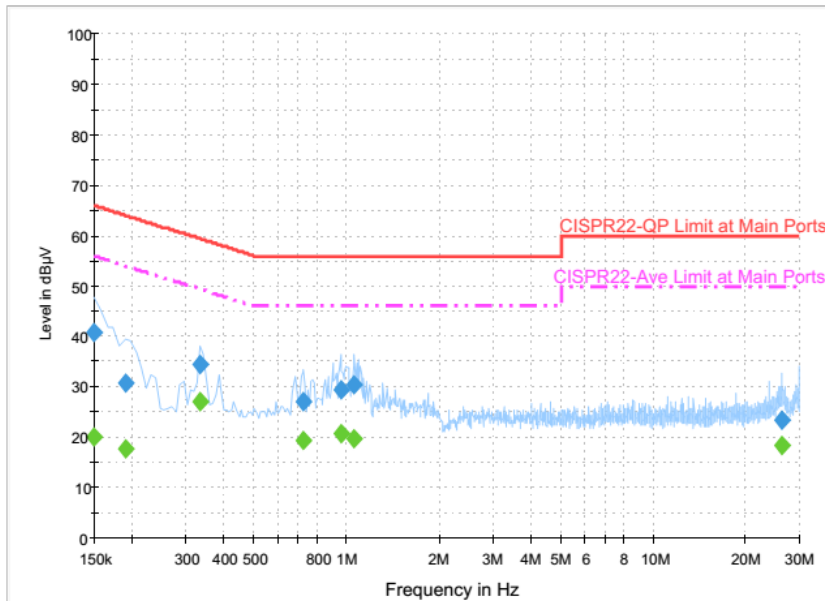

Final Result : QuasiPeak

Frequency (MHz)	QuasiPeak (dBµV)	Filter	Line	Corr. (dB)	Margin (dB)	Limit (dBµV)
0.150000	40.9	Off	L1	19.6	25.1	66.0
0.190000	30.7	Off	L1	19.6	33.3	64.0
0.334000	34.5	Off	L1	19.6	24.9	59.4
0.726000	27.1	Off	L1	19.6	28.9	56.0
0.958000	29.6	Off	L1	19.6	26.4	56.0
1.062000	30.3	Off	L1	19.6	25.7	56.0
26.342000	23.3	Off	L1	20.9	36.7	60.0

Final Result : Average

Frequency (MHz)	Average (dBµV)	Filter	Line	Corr. (dB)	Margin (dB)	Limit (dBµV)
0.150000	20.2	Off	L1	19.6	35.8	56.0
0.190000	17.6	Off	L1	19.6	36.4	54.0
0.334000	27.2	Off	L1	19.6	22.2	49.4
0.726000	19.3	Off	L1	19.6	26.7	46.0
0.958000	20.8	Off	L1	19.6	25.2	46.0
1.062000	19.8	Off	L1	19.6	26.2	46.0
26.342000	18.4	Off	L1	20.9	31.6	50.0



Test Mode :	Mode 1	Temperature :	22~25°C
Test Engineer :	Kai-Chun Chu	Relative Humidity :	52~55%
Test Voltage :	120Vac / 60Hz	Phase :	Neutral
Function Type :	WLAN On + BLE On + Zigbee On + Sensor On + LED On + IR LED On + Speaker On + Camera + AC to AC transformer		

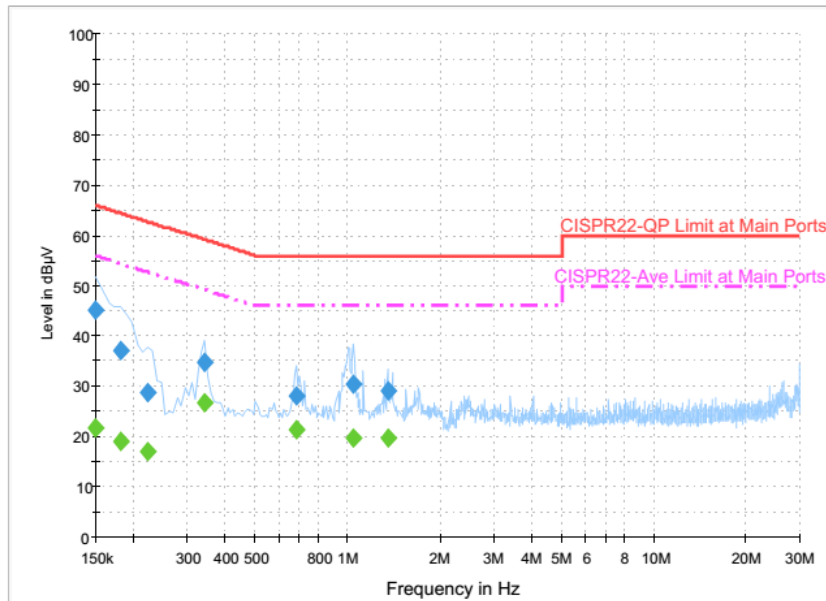

Final Result : QuasiPeak

Frequency (MHz)	QuasiPeak (dBµV)	Filter	Line	Corr. (dB)	Margin (dB)	Limit (dBµV)
0.150000	45.3	Off	N	19.5	20.7	66.0
0.182000	37.0	Off	N	19.5	27.4	64.4
0.222000	28.6	Off	N	19.5	34.1	62.7
0.342000	34.8	Off	N	19.5	24.4	59.2
0.678000	28.0	Off	N	19.5	28.0	56.0
1.046000	30.3	Off	N	19.6	25.7	56.0
1.350000	29.2	Off	N	19.6	26.8	56.0

Final Result : Average

Frequency (MHz)	Average (dBµV)	Filter	Line	Corr. (dB)	Margin (dB)	Limit (dBµV)
0.150000	21.7	Off	N	19.5	34.3	56.0
0.182000	18.9	Off	N	19.5	35.5	54.4
0.222000	17.0	Off	N	19.5	35.7	52.7
0.342000	26.6	Off	N	19.5	22.6	49.2
0.678000	21.4	Off	N	19.5	24.6	46.0
1.046000	19.9	Off	N	19.6	26.1	46.0
1.350000	19.8	Off	N	19.6	26.2	46.0



3.7 Antenna Requirements

3.7.1 Standard Applicable

If directional gain of transmitting Antennas is greater than 6dBi, the power shall be reduced by the same level in dB comparing to gain minus 6dBi. For the fixed point-to-point operation, the power shall be reduced by one dB for every 3 dB that the directional gain of the Antenna exceeds 6 dBi. The use of a permanently attached Antenna or of an Antenna that uses a unique coupling to the intentional radiator shall be considered sufficient to comply with the rule.

3.7.2 Antenna Anti-Replacement Construction

An embedded-in antenna design is used.

3.7.3 Antenna Gain

FCC KDB 662911 D01 Multiple Transmitter Output v02r01

For CDD transmissions, directional gain is calculated as

Directional gain = $G_{ANT} + \text{Array Gain}$, where Array Gain is as follows.

For power spectral density (PSD) measurements on all devices,

Array Gain = $10 \log(N_{ANT}/N_{SS}=1)$ dB.

For power measurements on IEEE 802.11 devices,

Array Gain = 0 dB (i.e., no array gain) for $N_{ANT} \leq 4$.

Directional gain may be calculated by using the formulas applicable to equal gain antennas with G_{ANT} set equal to the gain of the antenna having the highest gain;

The EUT supports CDD mode.

For power, the directional gain G_{ANT} is set equal to the antenna having the highest gain, i.e., F)2)f)i).

For PSD, the directional gain calculation is following F)2)f)ii) of KDB 662911 D01 v02r01.

The power and PSD limit should be modified if the directional gain of EUT is over 6 dBi,

The directional gain "DG" is calculated as following table.

	Ant. 1 (dBi)	Ant. 2 (dBi)	DG for Power (dBi)	DG for PSD (dBi)	Power Limit Reduction (dB)	PSD Limit Reduction (dB)
2.4 GHz	0.82	-0.16	0.82	3.35	0.00	0.00

Power Limit Reduction = $DG(\text{Power}) - 6\text{dBi}$, (min = 0)

PSD Limit Reduction = $DG(\text{PSD}) - 6\text{dBi}$, (min = 0)



4 List of Measuring Equipment

Instrument	Manufacturer	Model No.	Serial No.	Characteristics	Calibration Date	Test Date	Due Date	Remark
Power Meter	Anritsu	ML2495A	1240001	N/A	Sep. 07, 2017	Oct. 18, 2017 ~ Oct. 24, 2017	Sep. 06, 2018	Conducted (TH05-HY)
Power Sensor	Anritsu	MA2411B	1207349	300MHz~40GHz z	Sep. 07, 2017	Oct. 18, 2017 ~ Oct. 24, 2017	Sep. 06, 2018	Conducted (TH05-HY)
Spectrum Analyzer	Rohde & Schwarz	FSP40	100057	9kHz-40GHz	Nov. 25, 2016	Oct. 18, 2017 ~ Oct. 24, 2017	Nov. 24, 2017	Conducted (TH05-HY)
AC Power Source	ChainTek	APC-1000W	N/A	N/A	N/A	Jul. 22, 2017	N/A	Conduction (CO05-HY)
EMI Test Receiver	Rohde & Schwarz	ESCI 7	100724	9kHz~7GHz	Aug. 30, 2016	Jul. 22, 2017	Aug. 29, 2017	Conduction (CO05-HY)
LISN	Rohde & Schwarz	ENV216	100080	9kHz~30MHz	Nov. 29, 2016	Jul. 22, 2017	Nov. 28, 2017	Conduction (CO05-HY)
Preamplifier	MITEQ	TTA1840-35-HG	1887435	18GHz~40GHz	Oct. 13, 2016	Jul. 01, 2017 ~ Jul. 25, 2017	Oct. 12, 2017	Radiation (03CH11-HY)
Amplifier	MITEQ	TTA1840-35-HG	1871923	18GHz~40GHz, VSWR : 2.5:1 max	Jul. 18, 2017	Jul. 26, 2017 ~ Oct. 20, 2017	Jul. 17, 2018	Radiation (03CH11-HY)
Amplifier	SONOMA	310N	187312	9kHz~1GHz	Nov. 10, 2016	Jul. 01, 2017 ~ Oct. 20, 2017	Nov. 09, 2017	Radiation (03CH11-HY)
Loop Antenna	Rohde & Schwarz	HFH2-Z2	100488	9 kHz~30 MHz	Oct. 20, 2016	Jul. 01, 2017 ~ Oct. 20, 2017	Oct. 19, 2018	Radiation (03CH11-HY)
Preamplifier	Keysight	83017A	MY532700 80	1GHz~26.5GHz	Nov. 10, 2016	Jul. 01, 2017 ~ Oct. 20, 2017	Nov. 09, 2017	Radiation (03CH11-HY)
Preamplifier	MITEQ	AMF-7D-0010 1800-30-10P	1902247	1GHz~18GHz	Jun. 23, 2017	Jul. 01, 2017 ~ Oct. 20, 2017	Jun. 22, 2018	Radiation (03CH11-HY)
Antenna Mast	EMEC	AM-BS-4500-B	N/A	1~4m	N/A	Jul. 01, 2017 ~ Oct. 20, 2017	N/A	Radiation (03CH11-HY)
Turn Table	EMEC	TT 2000	N/A	0~360 Degree	N/A	Jul. 01, 2017 ~ Oct. 20, 2017	N/A	Radiation (03CH11-HY)
Bilog Antenna	TESEQ	CBL6111D&O 0800N1D01N- 06	41912&05	30MHz to 1GHz	Jan. 07, 2017	Jul. 01, 2017 ~ Oct. 20, 2017	Jan. 06, 2018	Radiation (03CH11-HY)
SHF-EHF Horn Antenna	SCHWARZBECK	BBHA 9170	BBHA9170 584	18GHz- 40GHz	Nov. 08, 2016	Jul. 01, 2017 ~ Oct. 20, 2017	Nov. 07, 2017	Radiation (03CH11-HY)
EMI Test Receiver	Agilent	N9038A(MXE)	MY532900 53	20Hz to 26.5GHz	Jan. 12, 2017	Jul. 01, 2017 ~ Oct. 20, 2017	Jan. 11, 2018	Radiation (03CH11-HY)
Horn Antenna	SCHWARZBECK	BBHA 9120 D	9120D-152 2	1G~18GHz	Mar. 17, 2017	Jul. 01, 2017 ~ Oct. 20, 2017	Mar. 16, 2018	Radiation (03CH11-HY)
Signal Analyzer	Rohde & Schwarz	FSV 30	100895	9kHz~30GHz	Apr. 25, 2017	Jul. 01, 2017 ~ Oct. 20, 2017	Apr. 24, 2018	Radiation (03CH11-HY)



5 Uncertainty of Evaluation

Uncertainty of Conducted Emission Measurement (150 kHz ~ 30 MHz)

Measuring Uncertainty for a Level of Confidence of 95% ($U = 2Uc(y)$)	2.70
---	------

Uncertainty of Radiated Emission Measurement (30 MHz ~ 1000 MHz)

Measuring Uncertainty for a Level of Confidence of 95% ($U = 2Uc(y)$)	5.20
---	------

Uncertainty of Radiated Emission Measurement (1000 MHz ~ 18000 MHz)

Measuring Uncertainty for a Level of Confidence of 95% ($U = 2Uc(y)$)	5.50
---	------

Uncertainty of Radiated Emission Measurement (18000 MHz ~ 40000 MHz)

Measuring Uncertainty for a Level of Confidence of 95% ($U = 2Uc(y)$)	5.20
---	------

Appendix A. Test Result of Conducted Test Items

Test Engineer:	Reece Lin /Aking Chang	Temperature:	21~25	°C
Test Date:	2017/10/18~2017/10/24	Relative Humidity:	51~54	%

TEST RESULTS DATA
6dB and 99% Occupied Bandwidth

2.4GHz Band										
Mod.	Data Rate	NTX	CH.	Freq. (MHz)	99% Occupied BW (MHz)		6dB BW (MHz)		6dB BW Limit (MHz)	Pass/Fail
					Ant 1	Ant 2	Ant 1	Ant 2		
11b	1Mbps	1	1	2412	11.70	11.95	8.54	9.06	0.50	Pass
11b	1Mbps	1	2	2417	11.70	12.20	8.04	9.00	0.50	Pass
11b	1Mbps	1	6	2437	11.80	11.95	8.54	9.06	0.50	Pass
11b	1Mbps	1	10	2457	11.75	12.00	9.00	9.04	0.50	Pass
11b	1Mbps	1	11	2462	11.75	12.05	8.02	9.06	0.50	Pass
11g	6Mbps	2	1	2412	18.35	18.20	16.34	16.32	0.50	Pass
11g	6Mbps	2	2	2417	18.10	18.15	16.32	16.32	0.50	Pass
11g	6Mbps	2	6	2437	18.65	18.70	16.32	16.32	0.50	Pass
11g	6Mbps	2	10	2457	18.35	18.25	16.32	16.32	0.50	Pass
11g	6Mbps	2	11	2462	18.35	18.15	16.32	16.30	0.50	Pass
HT20	MCS0	2	1	2412	18.85	19.00	17.52	17.58	0.50	Pass
HT20	MCS0	2	2	2417	19.00	18.95	17.56	17.58	0.50	Pass
HT20	MCS0	2	6	2437	19.25	19.30	17.54	17.58	0.50	Pass
HT20	MCS0	2	10	2457	19.00	18.85	17.60	17.56	0.50	Pass
HT20	MCS0	2	11	2462	19.05	18.85	17.56	17.60	0.50	Pass

TEST RESULTS DATA
Peak Output Power

2.4GHz Band																
Mod.	Data Rate	N _{TX}	CH.	Freq. (MHz)	Peak Conducted Power (dBm)			Conducted Power Limit (dBm)		DG (dBi)		EIRP Power (dBm)		EIRP Power Limit (dBm)		Pass /Fail
					Ant 1	Ant 2	SUM	Ant 1	Ant 2	Ant 1	Ant 2	Ant 1	Ant 2	Ant 1	Ant 2	
11b	1Mbps	1	1	2412	20.97	23.82		30.00	30.00	0.82	-0.16	21.79	23.66	36.00	36.00	Pass
11b	1Mbps	1	2	2417	22.13	24.37		30.00	30.00	0.82	-0.16	22.95	24.21	36.00	36.00	Pass
11b	1Mbps	1	6	2437	24.00	24.03		30.00	30.00	0.82	-0.16	24.82	23.87	36.00	36.00	Pass
11b	1Mbps	1	10	2457	21.55	24.10		30.00	30.00	0.82	-0.16	22.37	23.94	36.00	36.00	Pass
11b	1Mbps	1	11	2462	21.88	24.22		30.00	30.00	0.82	-0.16	22.70	24.06	36.00	36.00	Pass
11g	6Mbps	1	1	2412	21.40	23.00		30.00	30.00	0.82	-0.16	22.22	22.84	36.00	36.00	Pass
11g	6Mbps	1	2	2417	22.70	23.55		30.00	30.00	0.82	-0.16	23.52	23.39	36.00	36.00	Pass
11g	6Mbps	1	6	2437	24.55	24.70		30.00	30.00	0.82	-0.16	25.37	24.54	36.00	36.00	Pass
11g	6Mbps	1	10	2457	22.75	23.71		30.00	30.00	0.82	-0.16	23.57	23.55	36.00	36.00	Pass
11g	6Mbps	1	11	2462	21.85	23.23		30.00	30.00	0.82	-0.16	22.67	23.07	36.00	36.00	Pass
HT20	MCS0	1	1	2412	21.50	23.00		30.00	30.00	0.82	-0.16	22.32	22.84	36.00	36.00	Pass
HT20	MCS0	1	2	2417	23.05	24.00		30.00	30.00	0.82	-0.16	23.87	23.84	36.00	36.00	Pass
HT20	MCS0	1	6	2437	24.50	24.82		30.00	30.00	0.82	-0.16	25.32	24.66	36.00	36.00	Pass
HT20	MCS0	1	10	2457	22.95	23.81		30.00	30.00	0.82	-0.16	23.77	23.65	36.00	36.00	Pass
HT20	MCS0	1	11	2462	21.30	23.90		30.00	30.00	0.82	-0.16	22.12	23.74	36.00	36.00	Pass
VHT20	MCS0	1	1	2412	21.45	22.95		30.00	30.00	0.82	-0.16	22.27	22.79	36.00	36.00	Pass
VHT20	MCS0	1	2	2417	23.00	23.93		30.00	30.00	0.82	-0.16	23.82	23.77	36.00	36.00	Pass
VHT20	MCS0	1	6	2437	24.42	24.75		30.00	30.00	0.82	-0.16	25.24	24.59	36.00	36.00	Pass
VHT20	MCS0	1	10	2457	22.90	23.72		30.00	30.00	0.82	-0.16	23.72	23.56	36.00	36.00	Pass
VHT20	MCS0	1	11	2462	21.23	23.83		30.00	30.00	0.82	-0.16	22.05	23.67	36.00	36.00	Pass
11g	6Mbps	2	1	2412	21.42	23.02	25.30	30.00		0.82		26.12		36.00		Pass
11g	6Mbps	2	2	2417	22.71	23.60	26.19	30.00		0.82		27.01		36.00		Pass
11g	6Mbps	2	6	2437	24.60	24.74	27.68	30.00		0.82		28.50		36.00		Pass
11g	6Mbps	2	10	2457	22.80	23.75	26.31	30.00		0.82		27.13		36.00		Pass
11g	6Mbps	2	11	2462	21.90	23.26	25.64	30.00		0.82		26.46		36.00		Pass
HT20	MCS0	2	1	2412	21.53	23.04	25.36	30.00		0.82		26.18		36.00		Pass
HT20	MCS0	2	2	2417	23.10	24.03	26.60	30.00		0.82		27.42		36.00		Pass
HT20	MCS0	2	6	2437	24.51	24.85	27.69	30.00		0.82		28.51		36.00		Pass
HT20	MCS0	2	10	2457	23.00	23.85	26.46	30.00		0.82		27.28		36.00		Pass
HT20	MCS0	2	11	2462	21.31	23.93	25.82	30.00		0.82		26.64		36.00		Pass
VHT20	MCS0	2	1	2412	21.50	23.02	25.34	30.00		0.82		26.16		36.00		Pass
VHT20	MCS0	2	2	2417	23.05	24.00	26.56	30.00		0.82		27.38		36.00		Pass
VHT20	MCS0	2	6	2437	24.50	24.80	27.66	30.00		0.82		28.48		36.00		Pass
VHT20	MCS0	2	10	2457	22.92	23.80	26.39	30.00		0.82		27.21		36.00		Pass
VHT20	MCS0	2	11	2462	21.30	23.90	25.80	30.00		0.82		26.62		36.00		Pass

Note: Measured power (dBm) has offset with cable loss.

TEST RESULTS DATA
Average Output Power

2.4GHz Band									
Mod.	Data Rate	N _{TX}	CH.	Freq. (MHz)	Duty Factor (dB)		Average Conducted Power (dBm)		
					Ant 1	Ant 2	Ant 1	Ant 2	SUM
11b	1Mbps	1	1	2412	0.06	0.06	17.61	20.74	
11b	1Mbps	1	2	2417	0.06	0.06	18.81	21.72	
11b	1Mbps	1	6	2437	0.06	0.06	20.82	21.03	
11b	1Mbps	1	10	2457	0.06	0.06	18.23	21.17	
11b	1Mbps	1	11	2462	0.06	0.06	18.47	21.46	
11g	6Mbps	1	1	2412	0.32	0.32	14.32	15.87	
11g	6Mbps	1	2	2417	0.32	0.32	15.62	17.12	
11g	6Mbps	1	6	2437	0.32	0.32	19.12	20.12	
11g	6Mbps	1	10	2457	0.32	0.32	15.67	17.32	
11g	6Mbps	1	11	2462	0.32	0.32	15.02	16.47	
HT20	MCS0	1	1	2412	0.31	0.31	14.21	15.91	
HT20	MCS0	1	2	2417	0.31	0.31	15.71	17.46	
HT20	MCS0	1	6	2437	0.31	0.31	18.51	19.73	
HT20	MCS0	1	10	2457	0.31	0.31	15.66	17.31	
HT20	MCS0	1	11	2462	0.31	0.31	13.91	15.71	
VHT20	MCS0	1	1	2412	0.34	0.34	14.19	15.89	
VHT20	MCS0	1	2	2417	0.34	0.34	15.64	17.44	
VHT20	MCS0	1	6	2437	0.34	0.34	18.49	19.74	
VHT20	MCS0	1	10	2457	0.34	0.34	15.59	17.34	
VHT20	MCS0	1	11	2462	0.34	0.34	13.83	15.65	
11g	6Mbps	2	1	2412	0.32	0.30	14.35	15.90	18.21
11g	6Mbps	2	2	2417	0.32	0.30	15.65	17.14	19.47
11g	6Mbps	2	6	2437	0.32	0.30	19.16	20.17	22.71
11g	6Mbps	2	10	2457	0.32	0.30	15.70	17.37	19.63
11g	6Mbps	2	11	2462	0.32	0.30	15.03	16.50	18.84
HT20	MCS0	2	1	2412	0.31	0.31	14.26	15.92	18.18
HT20	MCS0	2	2	2417	0.31	0.31	15.72	17.49	19.71
HT20	MCS0	2	6	2437	0.31	0.31	18.56	19.81	22.24
HT20	MCS0	2	10	2457	0.31	0.31	15.70	17.39	19.64
HT20	MCS0	2	11	2462	0.31	0.31	13.92	15.76	17.95
VHT20	MCS0	2	1	2412	0.34	0.31	14.24	15.91	18.17
VHT20	MCS0	2	2	2417	0.34	0.31	15.69	17.46	19.68
VHT20	MCS0	2	6	2437	0.34	0.31	18.54	19.76	22.20
VHT20	MCS0	2	10	2457	0.34	0.31	15.65	17.36	19.60
VHT20	MCS0	2	11	2462	0.34	0.31	13.89	15.71	17.91

Note: Measured power (dBm) has offset with cable loss.

TEST RESULTS DATA
Peak Power Spectral Density

2.4GHz Band												
Mod.	Data Rate	NTX	CH.	Freq. (MHz)	Peak PSD (dBm/3kHz)			DG (dBi)		Peak PSD Limit (dBm/3kHz)		Pass/Fail
					Ant 1	Ant 2	Worse + 3.01	Ant 1	Ant 2	Ant 1	Ant 2	
11b	1Mbps	1	1	2412	-5.35	-1.79		0.82	-0.16	8.00	8.00	Pass
11b	1Mbps	1	2	2417	-4.59	-1.02		0.82	-0.16	8.00	8.00	Pass
11b	1Mbps	1	6	2437	-1.03	-1.54		0.82	-0.16	8.00	8.00	Pass
11b	1Mbps	1	10	2457	-5.55	-2.77		0.82	-0.16	8.00	8.00	Pass
11b	1Mbps	1	11	2462	-4.31	-1.33		0.82	-0.16	8.00	8.00	Pass
11g	6Mbps	2	1	2412	-12.26	-10.85	-7.84	3.35		8.00		Pass
11g	6Mbps	2	2	2417	-9.48	-7.74	-4.73	3.35		8.00		Pass
11g	6Mbps	2	6	2437	-5.78	-5.24	-2.23	3.35		8.00		Pass
11g	6Mbps	2	10	2457	-10.20	-7.78	-4.77	3.35		8.00		Pass
11g	6Mbps	2	11	2462	-9.67	-8.69	-5.68	3.35		8.00		Pass
HT20	MCS0	2	1	2412	-11.55	-10.48	-7.47	3.35		8.00		Pass
HT20	MCS0	2	2	2417	-9.67	-8.01	-5.00	3.35		8.00		Pass
HT20	MCS0	2	6	2437	-7.59	-5.88	-2.87	3.35		8.00		Pass
HT20	MCS0	2	10	2457	-10.80	-8.66	-5.65	3.35		8.00		Pass
HT20	MCS0	2	11	2462	-11.36	-9.79	-6.78	3.35		8.00		Pass

Measured power density (dBm) has offset with cable loss.



Appendix B. Radiated Spurious Emission

Test Engineer :	HAO Hsu, Jacky Hung, and Ken Wu	Temperature :	20~25°C
		Relative Humidity :	50-55%

2.4GHz 2400~2483.5MHz

WIFI 802.11b (Band Edge @ 3m)

WIFI	Note	Frequency	Level	Over	Limit	Read	Antenna	Cable	Preamp	Ant	Table	Peak	Pol.
Ant.				Limit	Line	Level	Factor	Loss	Factor	Pos	Pos	Avg.	
1		(MHz)	(dBμV/m)	(dB)	(dBμV/m)	(dBμV)	(dB/m)	(dB)	(dB)	(cm)	(deg)	(P/A)	(H/V)
802.11b CH 01 2412MHz		2386.13	61.98	-12.02	74	52.16	27.13	6.36	33.6	120	235	P	H
		2387.18	52.95	-1.05	54	43.13	27.13	6.36	33.6	120	235	A	H
	*	2412	110.4	-	-	100.51	27.18	6.37	33.59	120	235	P	H
	*	2412	106.53	-	-	96.64	27.18	6.37	33.59	120	235	A	H
		2386.86	59.69	-14.31	74	49.87	27.13	6.36	33.6	391	285	P	V
		2387.18	50.24	-3.76	54	40.42	27.13	6.36	33.6	391	285	A	V
	*	2412	107.96	-	-	98.07	27.18	6.37	33.59	391	285	P	V
	*	2412	104.06	-	-	94.17	27.18	6.37	33.59	391	285	A	V
802.11b CH 06 2437MHz		2389.52	61.27	-12.73	74	51.45	27.13	6.36	33.6	143	229	P	H
		2389.94	51.4	-2.6	54	41.57	27.13	6.36	33.59	143	229	A	H
	*	2437	115.2	-	-	105.21	27.27	6.38	33.59	143	229	P	H
	*	2437	111.2	-	-	101.21	27.27	6.38	33.59	143	229	A	H
		2483.83	59.1	-14.9	74	49.01	27.36	6.38	33.58	143	229	P	H
		2483.5	46.18	-7.82	54	36.09	27.36	6.38	33.58	143	229	A	H
		2389.1	55.95	-18.05	74	46.13	27.13	6.36	33.6	377	316	P	V
		2389.94	43.77	-10.23	54	33.94	27.13	6.36	33.59	377	316	A	V
	*	2437	110.91	-	-	100.92	27.27	6.38	33.59	377	316	P	V
	*	2437	106.96	-	-	96.97	27.27	6.38	33.59	377	316	A	V
		2492.02	56.02	-17.98	74	45.87	27.4	6.39	33.57	377	316	P	V
		2483.55	42.34	-11.66	54	32.25	27.36	6.38	33.58	377	316	A	V



802.11b CH 11 2462MHz	*	2462	110.78	-	-	100.74	27.31	6.38	33.58	134	236	P	H
	*	2462	106.96	-	-	96.92	27.31	6.38	33.58	134	236	A	H
		2483.76	60.24	-13.76	74	50.15	27.36	6.38	33.58	134	236	P	H
		2483.52	52.36	-1.64	54	42.27	27.36	6.38	33.58	134	236	A	H
	*	2462	108.45	-	-	98.41	27.31	6.38	33.58	375	287	P	V
	*	2462	104.67	-	-	94.63	27.31	6.38	33.58	375	287	A	V
		2483.6	58.52	-15.48	74	48.43	27.36	6.38	33.58	375	287	P	V
		2483.52	49.67	-4.33	54	39.58	27.36	6.38	33.58	375	287	A	V
Remark	1. No other spurious found. 2. All results are PASS against Peak and Average limit line.												



WIFI Ant. 1	Note	Frequency (MHz)	Level (dBμV/m)	Over Limit (dB)	Limit Line (dBμV/m)	Read Level (dBμV)	Antenna Factor (dB/m)	Cable Loss (dB)	Preamp Factor (dB)	Ant Pos (cm)	Table Pos (deg)	Peak Avg. (P/A)	Pol. (H/V)
802.11b CH 02 2417MHz		2389.8	59.68	-14.32	74	49.85	27.13	6.36	33.59	121	236	P	H
		2389.94	51.52	-2.48	54	41.69	27.13	6.36	33.59	121	236	A	H
	*	2417	111.06	-	-	101.17	27.18	6.37	33.59	121	236	P	H
	*	2417	107.27	-	-	97.38	27.18	6.37	33.59	121	236	A	H
		2389.38	58.23	-15.77	74	48.41	27.13	6.36	33.6	392	285	P	V
		2389.94	49.32	-4.68	54	39.49	27.13	6.36	33.59	392	285	A	V
	*	2417	108.9	-	-	99.01	27.18	6.37	33.59	392	285	P	V
	*	2417	105.08	-	-	95.19	27.18	6.37	33.59	392	285	A	V
802.11b CH 10 2457MHz	*	2457	111.61	-	-	101.57	27.31	6.38	33.58	132	231	P	H
	*	2457	107.73	-	-	97.69	27.31	6.38	33.58	132	231	A	H
		2483.68	60.53	-13.47	74	50.44	27.36	6.38	33.58	132	231	P	H
		2483.62	51.75	-2.25	54	41.66	27.36	6.38	33.58	132	231	A	H
	*	2457	107.54	-	-	97.5	27.31	6.38	33.58	379	317	P	V
	*	2457	103.73	-	-	93.69	27.31	6.38	33.58	379	317	A	V
		2484.04	57.22	-16.78	74	47.13	27.36	6.38	33.58	379	317	P	V
		2483.68	45.09	-8.91	54	35	27.36	6.38	33.58	379	317	A	V
Remark	1. No other spurious found. 2. All results are PASS against Peak and Average limit line.												



2.4GHz 2400~2483.5MHz

WIFI 802.11b (Harmonic @ 3m)

WIFI Ant. 1	Note	Frequency (MHz)	Level (dBμV/m)	Over Limit (dB)	Limit Line (dBμV/m)	Read Level (dBμV)	Antenna Factor (dB/m)	Cable Loss (dB)	Preamp Factor (dB)	Ant Pos (cm)	Table Pos (deg)	Peak Avg. (P/A)	Pol. (H/V)
802.11b CH 01 2412MHz		2262	54.88	-19.12	74	45.78	26.77	6.01	33.62	120	235	P	H
		2262	48.2	-5.8	54	39.1	26.77	6.01	33.62	120	235	A	H
		2714	55.36	-18.64	74	44.3	28.14	6.55	33.55	120	235	P	H
		2714	45.76	-8.24	54	34.7	28.14	6.55	33.55	120	235	A	H
		4824	40.52	-33.48	74	22.7	31.89	9.05	33.08	100	0	P	H
		2262	51.99	-22.01	74	42.89	26.77	6.01	33.62	391	285	P	V
		2262	44.55	-9.45	54	35.45	26.77	6.01	33.62	391	285	A	V
		2714	53.43	-20.57	74	42.37	28.14	6.55	33.55	391	285	P	V
		2714	43.87	-10.13	54	32.81	28.14	6.55	33.55	391	285	A	V
		4824	42.66	-31.34	74	24.84	31.89	9.05	33.08	100	0	P	V
802.11b CH 06 2437MHz		4874	39.5	-34.5	74	60.4	31.98	9.56	62.87	100	0	P	H
		7311	56.72	-17.28	74	70.48	37.16	11.31	62.69	100	206	P	H
		7311	50.8	-3.2	54	64.56	37.16	11.31	62.69	100	206	A	H
		4874	41.64	-32.36	74	62.54	31.98	9.56	62.87	100	0	P	V
		7311	58.35	-15.65	74	72.11	37.16	11.31	62.69	336	162	P	V
		7311	52.9	-1.1	54	66.66	37.16	11.31	62.69	336	162	A	V
802.11b CH 11 2462MHz		4924	39.75	-34.25	74	60.43	32.08	9.55	62.75	100	0	P	H
		7386	54.53	-19.47	74	68.14	37.45	11.3	62.74	106	208	P	H
		7386	47.53	-6.47	54	61.14	37.45	11.3	62.74	106	208	A	H
		4924	42.06	-31.94	74	62.74	32.08	9.55	62.75	100	0	P	V
		7386	56.92	-17.08	74	70.53	37.45	11.3	62.74	284	164	P	V
		7386	50.91	-3.09	54	64.52	37.45	11.3	62.74	284	164	A	V
Remark	1. No other spurious found. 2. All results are PASS against Peak and Average limit line.												



WIFI Ant. 1	Note	Frequency (MHz)	Level (dBμV/m)	Over Limit (dB)	Limit Line (dBμV/m)	Read Level (dBμV)	Antenna Factor (dB/m)	Cable Loss (dB)	Preamp Factor (dB)	Ant Pos (cm)	Table Pos (deg)	Peak Avg. (P/A)	Pol. (H/V)
802.11b CH 02 2417MHz		4834	40.79	-33.21	74	61.79	31.92	9.59	62.94	100	0	P	H
		7251	49.58	-24.42	74	63.41	36.98	11.33	62.66	100	0	P	H
		4834	41.16	-32.84	74	62.16	31.92	9.59	62.94	100	0	P	V
		7251	49.91	-24.09	74	63.74	36.98	11.33	62.66	100	0	P	V
802.11b CH 10 2457MHz		4914	39.07	-34.93	74	59.83	32.04	9.55	62.79	100	0	P	H
		7371	54.27	-19.73	74	67.91	37.39	11.3	62.73	100	207	P	H
		7371	47.74	-6.26	54	61.38	37.39	11.3	62.73	100	207	A	H
		4914	41.24	-32.76	74	62	32.04	9.55	62.79	100	0	P	V
		7371	57.99	-16.01	74	71.63	37.39	11.3	62.73	250	159	P	V
		7371	52.26	-1.74	54	65.9	37.39	11.3	62.73	250	159	A	V
Remark	1. No other spurious found. 2. All results are PASS against Peak and Average limit line.												



Emission below 1GHz

2.4GHz WIFI 802.11b (LF)

WIFI	Note	Frequency	Level	Over	Limit	Read	Antenna	Cable	Preamp	Ant	Table	Peak	Pol.
Ant.				Limit	Line	Level	Factor	Loss	Factor	Pos	Pos	Avg.	
1		(MHz)	(dBμV/m)	(dB)	(dBμV/m)	(dBμV)	(dB/m)	(dB)	(dB)	(cm)	(deg)	(P/A)	(H/V)
2.4GHz 802.11b LF		30	23.21	-16.79	40	30.5	24.36	0.82	32.5	-	-	P	H
		244.38	32.24	-13.76	46	44.8	17.8	1.95	32.38	-	-	P	H
		262.2	34.39	-11.61	46	44.9	19.7	2.09	32.38	-	-	P	H
		318.9	28.74	-17.26	46	39.25	19.46	2.31	32.36	-	-	P	H
		611.5	32.9	-13.1	46	36.3	25.88	3.09	32.46	-	-	P	H
		860	36.12	-9.88	46	34.75	29.42	3.67	31.87	100	261	P	H
		32.7	30.89	-9.11	40	39.74	22.81	0.82	32.49	-	-	P	V
		37.29	34.12	-5.88	40	45.45	20.33	0.82	32.49	100	178	P	V
		62.13	32.01	-7.99	40	51.7	11.76	1.02	32.49	-	-	P	V
		316.1	26.55	-19.45	46	37.1	19.42	2.31	32.36	-	-	P	V
		580	30.28	-15.72	46	33.89	25.72	3.03	32.44	-	-	P	V
	951.7	35.28	-10.72	46	31.61	30.86	3.82	31.18	-	-	P	V	
Remark	1. No other spurious found. 2. All results are PASS against limit line.												



2.4GHz 2400~2483.5MHz

WIFI 802.11b (Band Edge @ 3m)

WIFI	Note	Frequency	Level	Over	Limit	Read	Antenna	Cable	Preamp	Ant	Table	Peak	Pol.
Ant.				Limit	Line	Level	Factor	Loss	Factor	Pos	Pos	Avg.	
2		(MHz)	(dBμV/m)	(dB)	(dBμV/m)	(dBμV)	(dB/m)	(dB)	(dB)	(cm)	(deg)	(P/A)	(H/V)
802.11b CH 01 2412MHz		2389.91	60.96	-13.04	74	51.13	27.13	6.36	33.59	116	237	P	H
		2387.18	51.82	-2.18	54	42	27.13	6.36	33.6	116	237	A	H
	*	2412	108.13	-	-	98.24	27.18	6.37	33.59	116	237	P	H
	*	2412	104.15	-	-	94.26	27.18	6.37	33.59	116	237	A	H
		2389.8	60.57	-13.43	74	50.74	27.13	6.36	33.59	349	278	P	V
		2390	52.03	-1.97	54	42.2	27.13	6.36	33.59	349	278	A	V
	*	2412	107.86	-	-	97.97	27.18	6.37	33.59	349	278	P	V
	*	2412	103.97	-	-	94.08	27.18	6.37	33.59	349	278	A	V
802.11b CH 06 2437MHz		2386.16	55.63	-18.37	74	45.81	27.13	6.36	33.6	139	228	P	H
		2389.94	41.99	-12.01	54	32.16	27.13	6.36	33.59	139	228	A	H
	*	2437	109.26	-	-	99.27	27.27	6.38	33.59	139	228	P	H
	*	2437	105.37	-	-	95.38	27.27	6.38	33.59	139	228	A	H
		2489.01	56.6	-17.4	74	46.46	27.4	6.39	33.58	139	228	P	H
		2484.04	42.86	-11.14	54	32.77	27.36	6.38	33.58	139	228	A	H
		2384.48	55.38	-18.62	74	45.6	27.09	6.36	33.6	377	312	P	V
		2389.94	41.63	-12.37	54	31.8	27.13	6.36	33.59	377	312	A	V
	*	2437	107.7	-	-	97.71	27.27	6.38	33.59	377	312	P	V
	*	2437	103.69	-	-	93.7	27.27	6.38	33.59	377	312	A	V
		2492.3	56.28	-17.72	74	46.13	27.4	6.39	33.57	377	312	P	V
		2483.62	41.8	-12.2	54	31.71	27.36	6.38	33.58	377	312	A	V



802.11b CH 11 2462MHz	*	2462	109.47	-	-	99.43	27.31	6.38	33.58	112	235	P	H
	*	2462	105.53	-	-	95.49	27.31	6.38	33.58	112	235	A	H
		2484.04	60.23	-13.77	74	50.14	27.36	6.38	33.58	112	235	P	H
		2483.52	52.24	-1.76	54	42.15	27.36	6.38	33.58	112	235	A	H
	*	2462	108.05	-	-	98.01	27.31	6.38	33.58	335	282	P	V
	*	2462	104.12	-	-	94.08	27.31	6.38	33.58	335	282	A	V
		2483.64	58.78	-15.22	74	48.69	27.36	6.38	33.58	335	282	P	V
		2483.52	49.6	-4.4	54	39.51	27.36	6.38	33.58	335	282	A	V
Remark	1. No other spurious found. 2. All results are PASS against Peak and Average limit line.												



WIFI Ant. 2	Note	Frequency (MHz)	Level (dBμV/m)	Over Limit (dB)	Limit Line (dBμV/m)	Read Level (dBμV)	Antenna Factor (dB/m)	Cable Loss (dB)	Preamp Factor (dB)	Ant Pos (cm)	Table Pos (deg)	Peak Avg. (P/A)	Pol. (H/V)
802.11b CH 02 2417MHz		2389.94	59.9	-14.1	74	50.07	27.13	6.36	33.59	138	236	P	H
		2389.94	51.43	-2.57	54	41.6	27.13	6.36	33.59	138	236	A	H
	*	2417	109.24	-	-	99.35	27.18	6.37	33.59	138	236	P	H
	*	2417	105.29	-	-	95.4	27.18	6.37	33.59	138	236	A	H
		2389.66	59	-15	74	49.18	27.13	6.36	33.6	400	282	P	V
		2389.94	49.83	-4.17	54	40	27.13	6.36	33.59	400	282	A	V
	*	2417	108.08	-	-	98.19	27.18	6.37	33.59	400	282	P	V
	*	2417	104.17	-	-	94.28	27.18	6.37	33.59	400	282	A	V
802.11b CH 10 2457MHz	*	2457	109.76	-	-	99.72	27.31	6.38	33.58	113	232	P	H
	*	2457	105.9	-	-	95.86	27.31	6.38	33.58	113	232	A	H
		2483.62	60.2	-13.8	74	50.11	27.36	6.38	33.58	113	232	P	H
		2483.68	50.45	-3.55	54	40.36	27.36	6.38	33.58	113	232	A	H
	*	2457	107.28	-	-	97.24	27.31	6.38	33.58	388	272	P	V
	*	2457	103.41	-	-	93.37	27.31	6.38	33.58	388	272	A	V
		2483.56	57.75	-16.25	74	47.66	27.36	6.38	33.58	388	272	P	V
		2483.5	46.79	-7.21	54	36.7	27.36	6.38	33.58	388	272	A	V
Remark	1. No other spurious found. 2. All results are PASS against Peak and Average limit line.												



2.4GHz 2400~2483.5MHz

WIFI 802.11b (Harmonic @ 3m)

WIFI Ant. 2	Note	Frequency (MHz)	Level (dBμV/m)	Over Limit (dB)	Limit Line (dBμV/m)	Read Level (dBμV)	Antenna Factor (dB/m)	Cable Loss (dB)	Preamp Factor (dB)	Ant Pos (cm)	Table Pos (deg)	Peak Avg. (P/A)	Pol. (H/V)
802.11b CH 01 2412MHz		4824	41.85	-32.15	74	62.92	31.89	9.59	62.98	100	0	P	H
		4824	41.82	-32.18	74	62.89	31.89	9.59	62.98	100	0	P	V
802.11b CH 06 2437MHz		4874	42.33	-31.67	74	63.23	31.98	9.56	62.87	100	0	P	H
		7311	57.51	-16.49	74	71.27	37.16	11.31	62.69	229	206	P	H
		7311	52.61	-1.39	54	66.37	37.16	11.31	62.69	229	206	A	H
		4874	44.18	-29.82	74	65.08	31.98	9.56	62.87	100	0	P	V
		7311	54.86	-19.14	74	68.62	37.16	11.31	62.69	100	284	P	V
		7311	49.86	-4.14	54	63.62	37.16	11.31	62.69	100	284	A	V
802.11b CH 11 2462MHz		4924	43.14	-30.86	74	63.82	32.08	9.55	62.75	100	0	P	H
		7386	58.03	-15.97	74	71.64	37.45	11.3	62.74	227	208	P	H
		7386	53.1	-0.9	54	66.71	37.45	11.3	62.74	227	208	A	H
		4924	43.99	-30.01	74	64.67	32.08	9.55	62.75	100	0	P	V
		7386	56.55	-17.45	74	70.16	37.45	11.3	62.74	100	285	P	V
		7386	51.64	-2.36	54	65.25	37.45	11.3	62.74	100	285	A	V
Remark	1. No other spurious found. 2. All results are PASS against Peak and Average limit line.												



WIFI Ant. 2	Note	Frequency (MHz)	Level (dBμV/m)	Over Limit (dB)	Limit Line (dBμV/m)	Read Level (dBμV)	Antenna Factor (dB/m)	Cable Loss (dB)	Preamp Factor (dB)	Ant Pos (cm)	Table Pos (deg)	Peak Avg. (P/A)	Pol. (H/V)
802.11b CH 02 2417MHz		4834	43.34	-30.66	74	64.34	31.92	9.59	62.94	100	0	P	H
		7251	57.59	-16.41	74	71.42	36.98	11.33	62.66	246	205	P	H
		7251	51.76	-2.24	54	65.59	36.98	11.33	62.66	246	205	A	H
		4834	41.64	-32.36	74	62.64	31.92	9.59	62.94	100	0	P	V
		7251	54.68	-19.32	74	68.51	36.98	11.33	62.66	113	283	P	V
		7251	49.56	-4.44	54	63.39	36.98	11.33	62.66	113	283	A	V
802.11b CH 10 2457MHz		4914	43.36	-30.64	74	64.12	32.04	9.55	62.79	100	0	P	H
		7371	57.96	-16.04	74	71.6	37.39	11.3	62.73	229	207	P	H
		7371	53.02	-0.98	54	66.66	37.39	11.3	62.73	229	207	A	H
		4914	43.34	-30.66	74	64.1	32.04	9.55	62.79	100	0	P	V
		7371	56.48	-17.52	74	70.12	37.39	11.3	62.73	103	284	P	V
		7371	51.05	-2.95	54	64.69	37.39	11.3	62.73	103	284	A	V
Remark	<ol style="list-style-type: none"> No other spurious found. All results are PASS against Peak and Average limit line. 												



Emission below 1GHz

2.4GHz WIFI 802.11b (LF)

WIFI	Note	Frequency	Level	Over	Limit	Read	Antenna	Cable	Preamp	Ant	Table	Peak	Pol.
Ant.				Limit	Line	Level	Factor	Loss	Factor	Pos	Pos	Avg.	
2		(MHz)	(dBμV/m)	(dB)	(dBμV/m)	(dBμV)	(dB/m)	(dB)	(dB)	(cm)	(deg)	(P/A)	(H/V)
2.4GHz 802.11b LF		30	22.91	-17.09	40	30.2	24.36	0.82	32.5	-	-	P	H
		244.38	31.97	-14.03	46	44.53	17.8	1.95	32.38	-	-	P	H
		260.85	34.37	-11.63	46	44.83	19.75	2.09	32.38	-	-	P	H
		311.2	28.44	-17.56	46	39.05	19.36	2.31	32.37	-	-	P	H
		619.9	32.71	-13.29	46	35.87	26.06	3.15	32.46	-	-	P	H
		860	35.46	-10.54	46	34.09	29.42	3.67	31.87	100	251	P	H
		32.97	28.44	-11.56	40	37.29	22.81	0.82	32.49	-	-	P	V
		37.29	28.14	-11.86	40	39.47	20.33	0.82	32.49	-	-	P	V
		61.86	30.96	-9.04	40	50.65	11.76	1.02	32.49	100	183	P	V
		379.8	27.01	-18.99	46	35.8	21.02	2.48	32.34	-	-	P	V
		738.2	31.18	-14.82	46	32.06	27.95	3.4	32.36	-	-	P	V
		959.4	35.52	-10.48	46	31.38	31.18	3.9	31.12	-	-	P	V
Remark	1. No other spurious found. 2. All results are PASS against limit line.												



2.4GHz 2400~2483.5MHz

WIFI 802.11g (Band Edge @ 3m)

WIFI	Note	Frequency	Level	Over	Limit	Read	Antenna	Cable	Preamp	Ant	Table	Peak	Pol.
Ant.				Limit	Line	Level	Factor	Loss	Factor	Pos	Pos	Avg.	
1+2		(MHz)	(dBμV/m)	(dB)	(dBμV/m)	(dBμV)	(dB/m)	(dB)	(dB)	(cm)	(deg)	(P/A)	(H/V)
802.11g CH 01 2412MHz		2389.07	68.89	-5.11	74	59.07	27.13	6.36	33.6	118	223	P	H
		2389.91	52.03	-1.97	54	42.2	27.13	6.36	33.59	118	223	A	H
	*	2412	111.39	-	-	101.5	27.18	6.37	33.59	118	223	P	H
	*	2412	101.95	-	-	92.06	27.18	6.37	33.59	118	223	A	H
		2389.07	67.22	-6.78	74	57.4	27.13	6.36	33.6	349	258	P	V
		2389.07	50.21	-3.79	54	40.39	27.13	6.36	33.6	349	258	A	V
	*	2412	108.71	-	-	98.82	27.18	6.37	33.59	349	258	P	V
	*	2412	99.28	-	-	89.39	27.18	6.37	33.59	349	258	A	V
802.11g CH 06 2437MHz		2389.52	68.04	-5.96	74	58.22	27.13	6.36	33.6	113	224	P	H
		2389.94	52.21	-1.79	54	42.38	27.13	6.36	33.59	113	224	A	H
	*	2437	115.29	-	-	105.3	27.27	6.38	33.59	113	224	P	H
	*	2437	105.03	-	-	95.04	27.27	6.38	33.59	113	224	A	H
		2484.11	68.09	-5.91	74	58	27.36	6.38	33.58	113	224	P	H
		2483.55	52.16	-1.84	54	42.07	27.36	6.38	33.58	113	224	A	H
		2389.38	62.24	-11.76	74	52.42	27.13	6.36	33.6	384	262	P	V
		2389.94	48.36	-5.64	54	38.53	27.13	6.36	33.59	384	262	A	V
	*	2437	112.4	-	-	102.41	27.27	6.38	33.59	384	262	P	V
	*	2437	102.33	-	-	92.34	27.27	6.38	33.59	384	262	A	V
		2483.9	63.3	-10.7	74	53.21	27.36	6.38	33.58	384	262	P	V
		2483.97	47.72	-6.28	54	37.63	27.36	6.38	33.58	384	262	A	V



802.11g CH 11 2462MHz	*	2462	110.86	-	-	100.82	27.31	6.38	33.58	137	225	P	H
	*	2462	101.5	-	-	91.46	27.31	6.38	33.58	137	225	A	H
		2483.96	68.23	-5.77	74	58.14	27.36	6.38	33.58	137	225	P	H
		2483.52	52.24	-1.76	54	42.15	27.36	6.38	33.58	137	225	A	H
	*	2462	109.95	-	-	99.91	27.31	6.38	33.58	328	303	P	V
	*	2462	99.93	-	-	89.89	27.31	6.38	33.58	328	303	A	V
		2483.56	66.54	-7.46	74	56.45	27.36	6.38	33.58	328	303	P	V
		2483.52	49.77	-4.23	54	39.68	27.36	6.38	33.58	328	303	A	V
Remark	1. No other spurious found. 2. All results are PASS against Peak and Average limit line.												



WIFI Ant. 1+2	Note	Frequency (MHz)	Level (dBµV/m)	Over Limit (dB)	Limit Line (dBµV/m)	Read Level (dBµV)	Antenna Factor (dB/m)	Cable Loss (dB)	Preamp Factor (dB)	Ant Pos (cm)	Table Pos (deg)	Peak Avg. (P/A)	Pol. (H/V)
802.11g CH 02 2417MHz		2389.1	68.18	-5.82	74	58.36	27.13	6.36	33.6	117	224	P	H
		2389.24	52.75	-1.25	54	42.93	27.13	6.36	33.6	117	224	A	H
	*	2417	112.82	-	-	102.93	27.18	6.37	33.59	117	224	P	H
	*	2417	103.11	-	-	93.22	27.18	6.37	33.59	117	224	A	H
		2389.52	64.1	-9.9	74	54.28	27.13	6.36	33.6	341	260	P	V
		2389.66	50.15	-3.85	54	40.33	27.13	6.36	33.6	341	260	A	V
	*	2417	109.57	-	-	99.68	27.18	6.37	33.59	341	260	P	V
	*	2417	99.72	-	-	89.83	27.18	6.37	33.59	341	260	A	V
802.11g CH 10 2457MHz	*	2457	111.93	-	-	101.89	27.31	6.38	33.58	113	226	P	H
	*	2457	102.65	-	-	92.61	27.31	6.38	33.58	113	226	A	H
		2483.8	70.28	-3.72	74	60.19	27.36	6.38	33.58	113	226	P	H
		2483.5	53.04	-0.96	54	42.95	27.36	6.38	33.58	113	226	A	H
	*	2457	110.69	-	-	100.65	27.31	6.38	33.58	335	306	P	V
	*	2457	100.76	-	-	90.72	27.31	6.38	33.58	335	306	A	V
		2484.1	66.44	-7.56	74	56.35	27.36	6.38	33.58	335	306	P	V
		2483.68	49.24	-4.76	54	39.15	27.36	6.38	33.58	335	306	A	V
Remark	1. No other spurious found. 2. All results are PASS against Peak and Average limit line.												



2.4GHz 2400~2483.5MHz

WIFI 802.11g (Harmonic @ 3m)

WIFI Ant. 1+2	Note	Frequency (MHz)	Level (dBμV/m)	Over Limit (dB)	Limit Line (dBμV/m)	Read Level (dBμV)	Antenna Factor (dB/m)	Cable Loss (dB)	Preamp Factor (dB)	Ant Pos (cm)	Table Pos (deg)	Peak Avg. (P/A)	Pol. (H/V)
802.11g CH 01 2412MHz		2262	62.32	-11.68	74	53.22	26.77	6.01	33.62	118	223	P	H
		2262	49.01	-4.99	54	39.91	26.77	6.01	33.62	118	223	A	H
		4824	38.87	-35.13	74	59.94	31.89	9.59	62.98	100	0	P	H
		4824	40.1	-33.9	74	61.17	31.89	9.59	62.98	100	0	P	V
802.11g CH 06 2437MHz		4874	41.13	-32.87	74	62.03	31.98	9.56	62.87	100	0	P	H
		7311	62.66	-11.34	74	76.42	37.16	11.31	62.69	243	205	P	H
		7311	44.71	-9.29	54	58.47	37.16	11.31	62.69	243	205	A	H
		4874	41.44	-32.56	74	62.34	31.98	9.56	62.87	100	0	P	V
		7311	60.66	-13.34	74	74.42	37.16	11.31	62.69	243	158	P	V
		7311	43.62	-10.38	54	57.38	37.16	11.31	62.69	243	158	A	V
802.11g CH 11 2462MHz		4924	39.97	-34.03	74	60.65	32.08	9.55	62.75	100	0	P	H
		7386	58.47	-15.53	74	72.08	37.45	11.3	62.74	236	180	P	H
		7386	42.68	-11.32	54	56.29	37.45	11.3	62.74	236	180	A	H
		4924	40.09	-33.91	74	60.77	32.08	9.55	62.75	100	0	P	V
		7386	58.96	-15.04	74	72.57	37.45	11.3	62.74	281	169	P	V
		7386	43.14	-10.86	54	56.75	37.45	11.3	62.74	281	169	A	V
Remark	1. No other spurious found. 2. All results are PASS against Peak and Average limit line.												



2.4GHz 2400~2483.5MHz

WIFI 802.11n HT20 (Band Edge @ 3m)

WIFI Ant. 1+2	Note	Frequency (MHz)	Level (dBμV/m)	Over Limit (dB)	Limit Line (dBμV/m)	Read Level (dBμV)	Antenna Factor (dB/m)	Cable Loss (dB)	Preamp Factor (dB)	Ant Pos (cm)	Table Pos (deg)	Peak Avg. (P/A)	Pol. (H/V)
802.11n HT20 CH 01 2412MHz		2389.7	69.77	-4.23	74	59.95	27.13	6.36	33.6	121	224	P	H
		2389.91	52.37	-1.63	54	42.54	27.13	6.36	33.59	121	224	A	H
	*	2412	109.06	-	-	99.17	27.18	6.37	33.59	121	224	P	H
	*	2412	100.07	-	-	90.18	27.18	6.37	33.59	121	224	A	H
		2389.91	64.88	-9.12	74	55.05	27.13	6.36	33.59	389	261	P	V
		2389.91	49.35	-4.65	54	39.52	27.13	6.36	33.59	389	261	A	V
	*	2412	106.39	-	-	96.5	27.18	6.37	33.59	389	261	P	V
	*	2412	96.86	-	-	86.97	27.18	6.37	33.59	389	261	A	V
802.11n HT20 CH 06 2437MHz		2387.7	65.24	-8.76	74	55.42	27.13	6.36	33.6	114	226	P	H
		2389.8	51.28	-2.72	54	41.45	27.13	6.36	33.59	114	226	A	H
	*	2437	113.87	-	-	103.88	27.27	6.38	33.59	114	226	P	H
	*	2437	103.57	-	-	93.58	27.27	6.38	33.59	114	226	A	H
		2483.55	66.03	-7.97	74	55.94	27.36	6.38	33.58	114	226	P	H
		2483.62	51.84	-2.16	54	41.75	27.36	6.38	33.58	114	226	A	H
		2389.24	61.19	-12.81	74	51.37	27.13	6.36	33.6	379	261	P	V
		2389.94	47.22	-6.78	54	37.39	27.13	6.36	33.59	379	261	A	V
	*	2437	111.33	-	-	101.34	27.27	6.38	33.59	379	261	P	V
	*	2437	101.3	-	-	91.31	27.27	6.38	33.59	379	261	A	V
		2487.82	60.62	-13.38	74	50.48	27.4	6.39	33.58	379	261	P	V
	2483.69	47.64	-6.36	54	37.55	27.36	6.38	33.58	379	261	A	V	



802.11n HT20 CH 11 2462MHz	*	2462	109.64	-	-	99.6	27.31	6.38	33.58	137	231	P	H
	*	2462	100.18	-	-	90.14	27.31	6.38	33.58	137	231	A	H
		2484.04	70.72	-3.28	74	60.63	27.36	6.38	33.58	137	231	P	H
		2483.88	52.02	-1.98	54	41.93	27.36	6.38	33.58	137	231	A	H
	*	2462	108.31	-	-	98.27	27.31	6.38	33.58	327	301	P	V
	*	2462	98.62	-	-	88.58	27.31	6.38	33.58	327	301	A	V
		2484.76	68.53	-5.47	74	58.43	27.36	6.39	33.58	327	301	P	V
		2483.64	49.66	-4.34	54	39.57	27.36	6.38	33.58	327	301	A	V
Remark	1. No other spurious found. 2. All results are PASS against Peak and Average limit line.												



WIFI Ant. 1+2	Note	Frequency (MHz)	Level (dBμV/m)	Over Limit (dB)	Limit Line (dBμV/m)	Read Level (dBμV)	Antenna Factor (dB/m)	Cable Loss (dB)	Preamp Factor (dB)	Ant Pos (cm)	Table Pos (deg)	Peak Avg. (P/A)	Pol. (H/V)
802.11n HT20 CH 02 2417MHz		2389.52	67.41	-6.59	74	57.59	27.13	6.36	33.6	123	228	P	H
		2389.94	52.56	-1.44	54	42.73	27.13	6.36	33.59	123	228	A	H
	*	2417	111.44	-	-	101.55	27.18	6.37	33.59	123	228	P	H
	*	2417	101.41	-	-	91.52	27.18	6.37	33.59	123	228	A	H
		2388.54	64.39	-9.61	74	54.57	27.13	6.36	33.6	344	261	P	V
		2389.94	49.5	-4.5	54	39.67	27.13	6.36	33.59	344	261	A	V
	*	2417	108.27	-	-	98.38	27.18	6.37	33.59	344	261	P	V
802.11n HT20 CH 10 2457MHz	*	2417	98.16	-	-	88.27	27.18	6.37	33.59	344	261	A	V
	*	2457	111.71	-	-	101.67	27.31	6.38	33.58	112	230	P	H
	*	2457	101.74	-	-	91.7	27.31	6.38	33.58	112	230	A	H
		2483.5	68.69	-5.31	74	58.6	27.36	6.38	33.58	112	230	P	H
		2483.5	51.54	-2.46	54	41.45	27.36	6.38	33.58	112	230	A	H
	*	2457	108.86	-	-	98.82	27.31	6.38	33.58	338	301	P	V
	*	2457	99.83	-	-	89.79	27.31	6.38	33.58	338	301	A	V
Remark	1. No other spurious found.												
	2. All results are PASS against Peak and Average limit line.												



2.4GHz 2400~2483.5MHz

WIFI 802.11n HT20 (Harmonic @ 3m)

WIFI Ant. 1+2	Note	Frequency (MHz)	Level (dBμV/m)	Over Limit (dB)	Limit Line (dBμV/m)	Read Level (dBμV)	Antenna Factor (dB/m)	Cable Loss (dB)	Preamp Factor (dB)	Ant Pos (cm)	Table Pos (deg)	Peak Avg. (P/A)	Pol. (H/V)
802.11n HT20 CH 01 2412MHz		2262	55.56	-18.44	74	46.8	26.43	6.01	33.62	106	220	P	H
		2262	48.05	-5.95	54	39.29	26.43	6.01	33.62	106	220	A	H
		2714	53.17	-20.83	74	42.44	27.81	6.55	33.55	147	224	P	H
		2714	43.06	-30.94	74	32.33	27.81	6.55	33.55	147	224	A	H
		4824	43.15	-30.85	74	65.94	31.62	9.9	64.74	100	0	P	H
		2262	54.29	-19.71	74	45.53	26.43	6.01	33.62	400	274	P	V
		2262	47.35	-6.65	54	38.59	26.43	6.01	33.62	400	274	A	V
		2714	54.04	-19.96	74	43.31	27.81	6.55	33.55	335	271	P	V
		2714	42.3	-11.7	54	31.57	27.81	6.55	33.55	335	271	A	V
		4824	43.23	-30.77	74	66.02	31.62	9.9	64.74	100	0	P	V
802.11n HT20 CH 06 2437MHz		4874	47.56	-26.44	74	70.27	31.71	9.85	64.7	100	0	P	H
		7311	55.25	-18.75	74	70.53	37.43	11.65	64.82	100	161	P	H
		7311	39.46	-14.54	54	54.74	37.43	11.65	64.82	100	161	A	H
		4874	47.67	-26.33	74	70.38	31.71	9.85	64.7	100	0	P	V
		7311	54.7	-19.3	74	69.98	37.43	11.65	64.82	372	0	P	V
		7311	38.86	-15.14	54	54.14	37.43	11.65	64.82	372	0	A	V
802.11n HT20 CH 11 2462MHz		4924	43.37	-30.63	74	65.97	31.79	9.83	64.66	100	0	P	H
		7386	45.17	-28.83	74	60.19	37.82	11.64	64.86	100	0	P	H
		4924	44.47	-29.53	74	67.07	31.79	9.83	64.66	100	0	P	V
		7386	46.37	-27.63	74	61.39	37.82	11.64	64.86	100	0	P	V
Remark	1. No other spurious found. 2. All results are PASS against Peak and Average limit line.												



Emission below 1GHz

2.4GHz WIFI 802.11g (LF)

WIFI Ant. 1+2	Note	Frequency (MHz)	Level (dBμV/m)	Over Limit (dB)	Limit Line (dBμV/m)	Read Level (dBμV)	Antenna Factor (dB/m)	Cable Loss (dB)	Preamp Factor (dB)	Ant Pos (cm)	Table Pos (deg)	Peak Avg. (P/A)	Pol. (H/V)
2.4GHz 802.11g LF		30	22.85	-17.15	40	30.14	24.36	0.82	32.5	-	-	P	H
		244.65	33.24	-12.76	46	45.8	17.8	1.95	32.38	-	-	P	H
		261.39	35.05	-10.95	46	45.56	19.7	2.09	32.38	-	-	P	H
		339.9	28.86	-17.14	46	38.79	19.98	2.39	32.35	-	-	P	H
		610.8	33.37	-12.63	46	36.77	25.88	3.09	32.46	-	-	P	H
		850.9	35.86	-10.14	46	34.75	29.2	3.67	31.91	100	255	P	H
		31.89	31.52	-8.48	40	39.84	23.33	0.82	32.49	-	-	P	V
		38.37	34.11	-5.89	40	45.92	19.85	0.82	32.49	100	171	P	V
		62.4	31.59	-8.41	40	51.28	11.76	1.02	32.49	-	-	P	V
		379.8	26.12	-19.88	46	34.91	21.02	2.48	32.34	-	-	P	V
		659.8	30	-16	46	32.73	26.43	3.2	32.47	-	-	P	V
		957.3	35.62	-10.38	46	31.59	31.1	3.9	31.14	-	-	P	V
Remark	1. No other spurious found. 2. All results are PASS against limit line.												



Note symbol

*	Fundamental Frequency which can be ignored. However, the level of any unwanted emissions shall not exceed the level of the fundamental frequency.
!	Test result is over limit line.
P/A	Peak or Average
H/V	Horizontal or Vertical



A calculation example for radiated spurious emission is shown as below:

WIFI	Note	Frequency	Level	Over	Limit	Read	Antenna	Cable	Preamp	Ant	Table	Peak	Pol.
Ant.				Limit	Line	Level	Factor	Loss	Factor	Pos	Pos	Avg.	
1+2		(MHz)	(dBμV/m)	(dB)	(dBμV/m)	(dBμV)	(dB/m)	(dB)	(dB)	(cm)	(deg)	(P/A)	(H/V)
802.11b		2390	55.45	-18.55	74	54.51	32.22	4.58	35.86	103	308	P	H
CH 01													
2412MHz		2390	43.54	-10.46	54	42.6	32.22	4.58	35.86	103	308	A	H

- 1. Level(dBμV/m) =
Antenna Factor(dB/m) + Cable Loss(dB) + Read Level(dBμV) - Preamp Factor(dB)
- 2. Over Limit(dB) = Level(dBμV/m) – Limit Line(dBμV/m)

For Peak Limit @ 2390MHz:

- 1. Level(dBμV/m)
= Antenna Factor(dB/m) + Cable Loss(dB) + Read Level(dBμV) - Preamp Factor(dB)
= 32.22(dB/m) + 4.58(dB) + 54.51(dBμV) – 35.86 (dB)
= 55.45 (dBμV/m)
- 2. Over Limit(dB)
= Level(dBμV/m) – Limit Line(dBμV/m)
= 55.45(dBμV/m) – 74(dBμV/m)
= -18.55(dB)

For Average Limit @ 2390MHz:

- 1. Level(dBμV/m)
= Antenna Factor(dB/m) + Cable Loss(dB) + Read Level(dBμV) - Preamp Factor(dB)
= 32.22(dB/m) + 4.58(dB) + 42.6(dBμV) – 35.86 (dB)
= 43.54 (dBμV/m)
- 2. Over Limit(dB)
= Level(dBμV/m) – Limit Line(dBμV/m)
= 43.54(dBμV/m) – 54(dBμV/m)
= -10.46(dB)

Both peak and average measured complies with the limit line, so test result is “PASS”.



Appendix C. Radiated Spurious Emission Plots

Test Engineer :	HAO Hsu, Jacky Hung, and Ken Wu	Temperature :	20~25°C
		Relative Humidity :	50-55%

Note symbol

-L	Low channel location
-R	High channel location



2.4GHz 2400~2483.5MHz

WIFI 802.11b (Band Edge @ 3m)

WIFI	2.4GHz 2400~2483.5MHz Band Edge @ 3m	
ANT	802.11b CH01 2412MHz	
1	Horizontal	Fundamental
Peak	<p>Site : 03CH11-HY Condition : PEAK_BE_74 3m HORN 91200-HF HORIZONTAL</p>	<p>Site : 03CH11-HY Condition : PEAK_74 3m HORN 91200-HF HORIZONTAL</p>
Avg.	<p>Site : 03CH11-HY Condition : AV6_BE_54 3m HORN 91200-HF HORIZONTAL</p>	<p>Site : 03CH11-HY Condition : AV6_54 3m HORN 91200-HF HORIZONTAL</p>



WIFI	2.4GHz 2400~2483.5MHz Band Edge @ 3m	
ANT	802.11b CH01 2412MHz	
1	Vertical	Fundamental
Peak	<p>Site : 03CHI1-HY Condition : PEAK_BE_74 3m HORN 91200-HF VERTICAL</p>	<p>Site : 03CHI1-HY Condition : PEAK_74 3m HORN 91200-HF VERTICAL</p>
Avg.	<p>Site : 03CHI1-HY Condition : AV6_BE_54 3m HORN 91200-HF VERTICAL</p>	<p>Site : 03CHI1-HY Condition : AV6_54 3m HORN 91200-HF VERTICAL</p>



WIFI	2.4GHz 2400~2483.5MHz Band Edge @ 3m	
ANT	802.11b CH02 2417MHz	
1	Horizontal	Fundamental
Peak	<p>Site : 03CH11-HY Condition : PEAK_BE_74 3m HORN 91200-HF HORIZONTAL</p>	<p>Site : 03CH11-HY Condition : PEAK_74 3m HORN 91200-HF HORIZONTAL</p>
Avg.	<p>Site : 03CH11-HY Condition : AV6_BE_54 3m HORN 91200-HF HORIZONTAL</p>	<p>Site : 03CH11-HY Condition : AV6_54 3m HORN 91200-HF HORIZONTAL</p>



WIFI	2.4GHz 2400~2483.5MHz Band Edge @ 3m	
ANT	802.11b CH02 2417MHz	
1	Vertical	Fundamental
Peak	<p>Site : 03CHI1-HY Condition : PEAK_BE_74 3m HORN 91200-HF VERTICAL</p>	<p>Site : 03CHI1-HY Condition : PEAK_74 3m HORN 91200-HF VERTICAL</p>
Avg.	<p>Site : 03CHI1-HY Condition : AV6_BE_54 3m HORN 91200-HF VERTICAL</p>	<p>Site : 03CHI1-HY Condition : AV6_54 3m HORN 91200-HF VERTICAL</p>

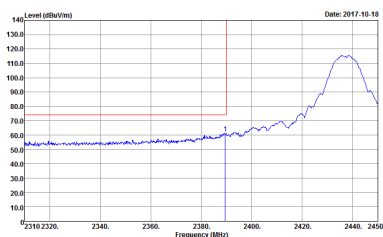
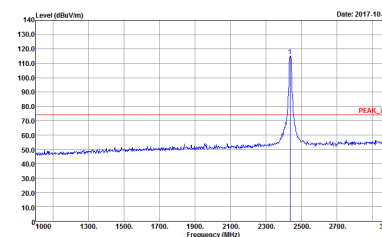
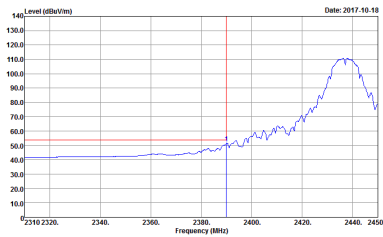
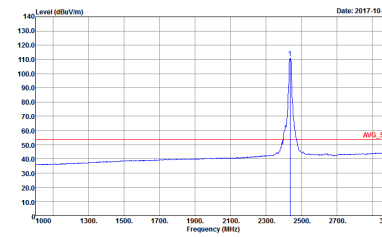

WIFI	2.4GHz 2400~2483.5MHz Band Edge @ 3m	
ANT	802.11b CH06 2437MHz - L	
1	Horizontal	Fundamental
Peak	 <p>Site : 03CH11-HY Condition : PEAK_BE_74 3m HORN 91200-HF HORIZONTAL</p>	 <p>Site : 03CH11-HY Condition : PEAK_74 3m HORN 91200-HF HORIZONTAL</p>
Avg.	 <p>Site : 03CH11-HY Condition : AV6_BE_54 3m HORN 91200-HF HORIZONTAL</p>	 <p>Site : 03CH11-HY Condition : AV6_54 3m HORN 91200-HF HORIZONTAL</p>

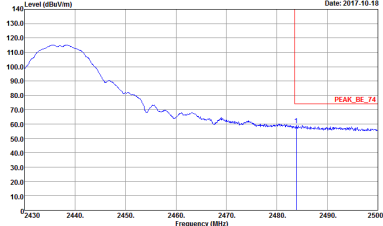
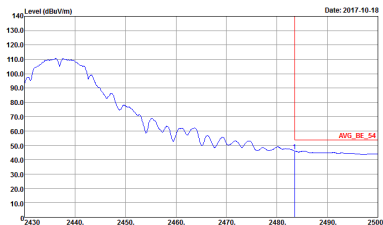

WIFI	2.4GHz 2400~2483.5MHz Band Edge @ 3m	
ANT	802.11b CH06 2437MHz - R	
1	Horizontal	Fundamental
<p>Peak</p>	 <p>Site : 03CH11-HY Condition : PEAK_BE_74 3m HORN 91200-HF HORIZONTAL</p>	<p>Left blank</p>
<p>Avg.</p>	 <p>Site : 03CH11-HY Condition : AVG_BE_54 3m HORN 91200-HF HORIZONTAL</p>	<p>Left blank</p>



WIFI	2.4GHz 2400~2483.5MHz Band Edge @ 3m	
ANT	802.11b CH06 2437MHz - L	
1	Vertical	Fundamental
Peak	<p>Site : 03CHI1-HY Condition : PEAK_BE_74 3m HORN 91200-HF VERTICAL</p>	<p>Site : 03CHI1-HY Condition : PEAK_74 3m HORN 91200-HF VERTICAL</p>
Avg.	<p>Site : 03CHI1-HY Condition : AV6_BE_54 3m HORN 91200-HF VERTICAL</p>	<p>Site : 03CHI1-HY Condition : AV6_54 3m HORN 91200-HF VERTICAL</p>

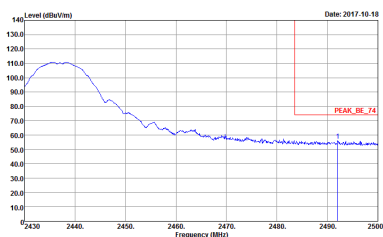
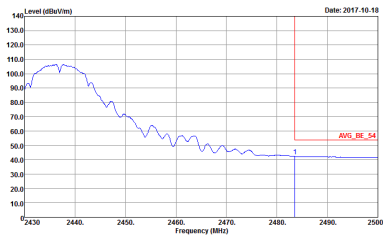

WIFI	2.4GHz 2400~2483.5MHz Band Edge @ 3m	
ANT	802.11b CH06 2437MHz - R	
1	Vertical	Fundamental
<p>Peak</p>	 <p>Site : 03CH11-HY Condition : PEAK_BE_74 3m HORN 91200-HF VERTICAL</p>	<p>Left blank</p>
<p>Avg.</p>	 <p>Site : 03CH11-HY Condition : AVG_BE_54 3m HORN 91200-HF VERTICAL</p>	<p>Left blank</p>



WIFI	2.4GHz 2400~2483.5MHz Band Edge @ 3m	
ANT	802.11b CH10 2457MHz	
1	Horizontal	Fundamental
Peak	<p>Site : 03CH11-HY Condition : PEAK_BE_74 3m HORN 91200-HF HORIZONTAL</p>	<p>Site : 03CH11-HY Condition : PEAK_74 3m HORN 91200-HF HORIZONTAL</p>
Avg.	<p>Site : 03CH11-HY Condition : AVG_BE_54 3m HORN 91200-HF HORIZONTAL</p>	<p>Site : 03CH11-HY Condition : AVG_54 3m HORN 91200-HF HORIZONTAL</p>



WIFI	2.4GHz 2400~2483.5MHz Band Edge @ 3m	
ANT	802.11b CH10 2457MHz	
1	Vertical	Fundamental
Peak	<p>Site : 03CH11-HY Condition : PEAK_BE_74 3m HORN 9120D-HF VERTICAL</p>	<p>Site : 03CH11-HY Condition : PEAK_74 3m HORN 9120D-HF VERTICAL</p>
Avg.	<p>Site : 03CH11-HY Condition : AVG_BE_54 3m HORN 9120D-HF VERTICAL</p>	<p>Site : 03CH11-HY Condition : AVG_54 3m HORN 9120D-HF VERTICAL</p>



WIFI	2.4GHz 2400~2483.5MHz Band Edge @ 3m	
ANT	802.11b CH11 2462MHz	
1	Horizontal	Fundamental
Peak	<p>Site : 03CH11-HY Condition : PEAK_BE_74 3m HORN 91200-HF HORIZONTAL</p>	<p>Site : 03CH11-HY Condition : PEAK_74 3m HORN 91200-HF HORIZONTAL</p>
Avg.	<p>Site : 03CH11-HY Condition : AV6_BE_54 3m HORN 91200-HF HORIZONTAL</p>	<p>Site : 03CH11-HY Condition : AV6_54 3m HORN 91200-HF HORIZONTAL</p>



WIFI	2.4GHz 2400~2483.5MHz Band Edge @ 3m	
ANT	802.11b CH11 2462MHz	
1	Vertical	Fundamental
Peak	<p>Site : 03CH11-HY Condition : PEAK_BE_74 3m HORN 91200-HF VERTICAL</p>	<p>Site : 03CH11-HY Condition : PEAK_74 3m HORN 91200-HF VERTICAL</p>
Avg.	<p>Site : 03CH11-HY Condition : AVG_BE_54 3m HORN 91200-HF VERTICAL</p>	<p>Site : 03CH11-HY Condition : AVG_54 3m HORN 91200-HF VERTICAL</p>



2.4GHz 2400~2483.5MHz

WIFI 802.11b (Harmonic @ 3m)

WIFI	2.4GHz 2400~2483.5MHz Harmonic @ 3m	
ANT	802.11b CH01 2412MHz	
1	Horizontal	Vertical
Peak Avg.	<p>Site : 03CH11-14Y Condition : PEAK_74 3m HORN 9120D-HF HORIZONTAL</p>	<p>Site : 03CH11-14Y Condition : PEAK_74 3m HORN 9120D-HF VERTICAL</p>

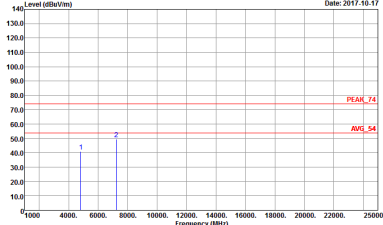
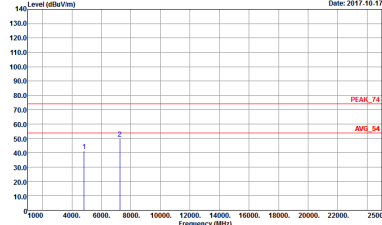

WIFI	2.4GHz 2400~2483.5MHz Harmonic @ 3m	
ANT	802.11b CH02 2417MHz	
1	Horizontal	Vertical
Peak Avg.	 <p>Site : 03CH11-14F Condition : PEAK_74 3m HORN 91200-HF HORIZONTAL</p>	 <p>Site : 03CH11-14F Condition : PEAK_74 3m HORN 91200-HF VERTICAL</p>



WIFI	2.4GHz 2400~2483.5MHz Harmonic @ 3m	
ANT	802.11b CH06 2437MHz	
1	Horizontal	Vertical
Peak Avg.	<p>Site : 03CH11-4F Condition : PEAK_74 3m HORN 91200-HF HORIZONTAL</p>	<p>Site : 03CH11-4F Condition : PEAK_74 3m HORN 91200-HF VERTICAL</p>



WIFI	2.4GHz 2400~2483.5MHz Harmonic @ 3m	
ANT	802.11b CH10 2457MHz	
1	Horizontal	Vertical
Peak Avg.	<p>Site : 03CH11-49F Condition : PEAK_74 3m HORN 91200-HF HORIZONTAL</p>	<p>Site : 03CH11-49F Condition : PEAK_74 3m HORN 91200-HF VERTICAL</p>



WIFI	2.4GHz 2400~2483.5MHz Harmonic @ 3m	
ANT	802.11b CH11 2462MHz	
1	Horizontal	Vertical
Peak Avg.	<p>Site : 03CH11-4F Condition : PEAK_74 3m HORN 91200-HF HORIZONTAL</p>	<p>Site : 03CH11-4F Condition : PEAK_74 3m HORN 91200-HF VERTICAL</p>



Emission below 1GHz

2.4GHz WIFI 802.11b (LF)

WIFI	2.4GHz 2400~2483.5MHz	
ANT	802.11b LF	
1	Horizontal	Vertical
QP / Peak	<p>Site : 03CH11-HY Condition : QP-3m 81-LOG-6111D-LF_ETC HORIZONTAL</p>	<p>Site : 03CH11-HY Condition : QP-3m 81-LOG-6111D-LF_ETC VERTICAL</p>



2.4GHz 2400~2483.5MHz

WIFI 802.11b (Band Edge @ 3m)

WIFI	2.4GHz 2400~2483.5MHz Band Edge @ 3m	
ANT	802.11b CH01 2412MHz	
2	Horizontal	Fundamental
Peak	<p>Site : 03CH11-HY Condition : PEAK_BE_74 3m HORN 9120D-HF HORIZONTAL</p>	<p>Site : 03CH11-HY Condition : PEAK_74 3m HORN 9120D-HF HORIZONTAL</p>
Avg.	<p>Site : 03CH11-HY Condition : AV6_BE_54 3m HORN 9120D-HF HORIZONTAL</p>	<p>Site : 03CH11-HY Condition : AV6_54 3m HORN 9120D-HF HORIZONTAL</p>



WIFI	2.4GHz 2400~2483.5MHz Band Edge @ 3m	
ANT	802.11b CH01 2412MHz	
2	Vertical	Fundamental
Peak	<p>Site : 03CHI1-HY Condition : PEAK_BE_74 3m HORN 9120D-HF VERTICAL</p>	<p>Site : 03CHI1-HY Condition : PEAK_74 HORN 9120D-HF VERTICAL</p>
Avg.	<p>Site : 03CHI1-HY Condition : AV6_BE_54 3m HORN 9120D-HF VERTICAL</p>	<p>Site : 03CHI1-HY Condition : AV6_54 3m HORN 9120D-HF VERTICAL</p>



WIFI	2.4GHz 2400~2483.5MHz Band Edge @ 3m	
ANT	802.11b CH02 2417MHz	
2	Horizontal	Fundamental
Peak	<p>Site : 03CH11-HY Condition : PEAK_BE_74 3m HORN 9120D-HF HORIZONTAL</p>	<p>Site : 03CH11-HY Condition : PEAK_74 3m HORN 9120D-HF HORIZONTAL</p>
Avg.	<p>Site : 03CH11-HY Condition : AV6_BE_54 3m HORN 9120D-HF HORIZONTAL</p>	<p>Site : 03CH11-HY Condition : AV6_54 3m HORN 9120D-HF HORIZONTAL</p>



WIFI	2.4GHz 2400~2483.5MHz Band Edge @ 3m	
ANT	802.11b CH02 2417MHz	
2	Vertical	Fundamental
Peak	<p>Site : 03CHI1-HY Condition : PEAK_BE_74 3m HORN 9120D-HF VERTICAL</p>	<p>Site : 03CHI1-HY Condition : PEAK_74 3m HORN 9120D-HF VERTICAL</p>
Avg.	<p>Site : 03CHI1-HY Condition : AV6_BE_54 3m HORN 9120D-HF VERTICAL</p>	<p>Site : 03CHI1-HY Condition : AV6_54 3m HORN 9120D-HF VERTICAL</p>



WIFI	2.4GHz 2400~2483.5MHz Band Edge @ 3m	
ANT	802.11b CH06 2437MHz - L	
2	Horizontal	Fundamental
Peak	<p>Site : 03CHI1-HY Condition : PEAK_BE_74 3m HORN 9120D-HF HORIZONTAL</p>	<p>Site : 03CHI1-HY Condition : PEAK_74 3m HORN 9120D-HF HORIZONTAL</p>
Avg.	<p>Site : 03CHI1-HY Condition : AV6_BE_54 3m HORN 9120D-HF HORIZONTAL</p>	<p>Site : 03CHI1-HY Condition : AV6_54 3m HORN 9120D-HF HORIZONTAL</p>

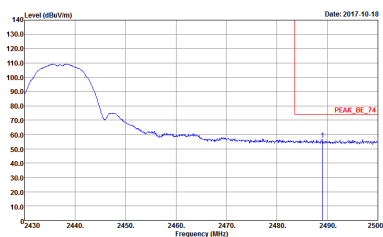
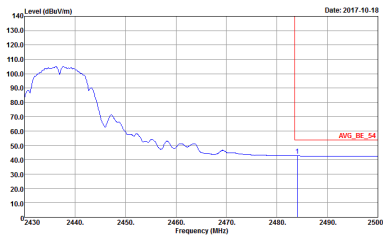

WIFI	2.4GHz 2400~2483.5MHz Band Edge @ 3m	
ANT	802.11b CH06 2437MHz - R	
2	Horizontal	Fundamental
Peak	 <p>Site : 03CH11-HY Condition : PEAK_BE_74 3m HORN 91200-HF HORIZONTAL</p>	Left blank
Avg.	 <p>Site : 03CH11-HY Condition : AVG_BE_54 3m HORN 91200-HF HORIZONTAL</p>	Left blank

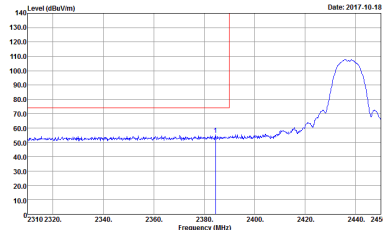
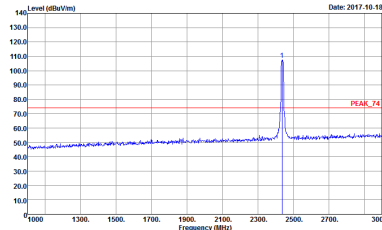
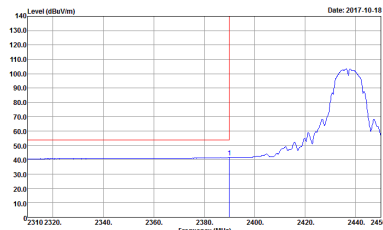
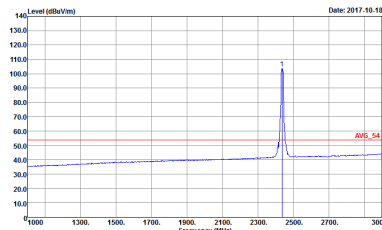

WIFI	2.4GHz 2400~2483.5MHz Band Edge @ 3m	
ANT	802.11b CH06 2437MHz - L	
2	Vertical	Fundamental
Peak	 <p>Site : 03CHI1-HY Condition : PEAK_BE_74 3m HORN 9120D-HF VERTICAL</p>	 <p>Site : 03CHI1-HY Condition : PEAK_74 3m HORN 9120D-HF VERTICAL</p>
Avg.	 <p>Site : 03CHI1-HY Condition : AV6_BE_54 3m HORN 9120D-HF VERTICAL</p>	 <p>Site : 03CHI1-HY Condition : AV6_54 3m HORN 9120D-HF VERTICAL</p>



WIFI	2.4GHz 2400~2483.5MHz Band Edge @ 3m	
ANT	802.11b CH06 2437MHz - R	
2	Vertical	Fundamental
<p>Peak</p>	<p>Site : 03CH11-HY Condition : PEAK_BE_74 3m HORN 91200-HF VERTICAL</p>	<p>Left blank</p>
<p>Avg.</p>	<p>Site : 03CH11-HY Condition : AVG_BE_54 3m HORN 91200-HF VERTICAL</p>	<p>Left blank</p>



WIFI	2.4GHz 2400~2483.5MHz Band Edge @ 3m	
ANT	802.11b CH10 2457MHz	
2	Horizontal	Fundamental
Peak	<p>Site : 03CH11-HY Condition : PEAK_BE_74 3m HORN 9120D-HF HORIZONTAL</p>	<p>Site : 03CH11-HY Condition : PEAK_74 3m HORN 9120D-HF HORIZONTAL</p>
Avg.	<p>Site : 03CH11-HY Condition : AVG_BE_54 3m HORN 9120D-HF HORIZONTAL</p>	<p>Site : 03CH11-HY Condition : AVG_54 3m HORN 9120D-HF HORIZONTAL</p>



WIFI	2.4GHz 2400~2483.5MHz Band Edge @ 3m	
ANT	802.11b CH10 2457MHz	
2	Vertical	Fundamental
Peak	<p>Site : 03CH11-HY Condition : PEAK_BE_74 3m HORN 9120D-HF VERTICAL</p>	<p>Site : 03CH11-HY Condition : PEAK_74 3m HORN 9120D-HF VERTICAL</p>
Avg.	<p>Site : 03CH11-HY Condition : AVG_BE_54 3m HORN 9120D-HF VERTICAL</p>	<p>Site : 03CH11-HY Condition : AVG_54 3m HORN 9120D-HF VERTICAL</p>



WIFI	2.4GHz 2400~2483.5MHz Band Edge @ 3m	
ANT	802.11b CH11 2462MHz	
2	Horizontal	Fundamental
Peak	<p>Site : 03CH11-HY Condition : PEAK_BE_74 3m HORN 91200-HF HORIZONTAL</p>	<p>Site : 03CH11-HY Condition : PEAK_74 3m HORN 91200-HF HORIZONTAL</p>
Avg.	<p>Site : 03CH11-HY Condition : AVG_BE_54 3m HORN 91200-HF HORIZONTAL</p>	<p>Site : 03CH11-HY Condition : AVG_54 3m HORN 91200-HF HORIZONTAL</p>



WIFI	2.4GHz 2400~2483.5MHz Band Edge @ 3m	
ANT	802.11b CH11 2462MHz	
2	Vertical	Fundamental
Peak	<p>Site : 03CH11-HY Condition : PEAK_BE_74 3m HORN 91200-HF VERTICAL</p>	<p>Site : 03CH11-HY Condition : PEAK_74 3m HORN 91200-HF VERTICAL</p>
Avg.	<p>Site : 03CH11-HY Condition : AVG_BE_54 3m HORN 91200-HF VERTICAL</p>	<p>Site : 03CH11-HY Condition : AVG_54 3m HORN 91200-HF VERTICAL</p>



2.4GHz 2400~2483.5MHz

WIFI 802.11b (Harmonic @ 3m)

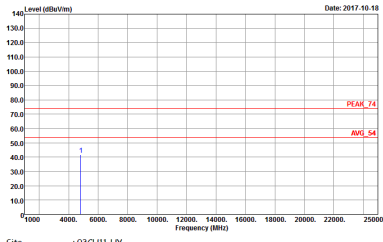
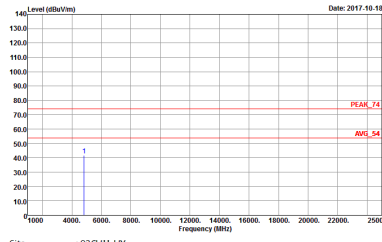
WIFI	2.4GHz 2400~2483.5MHz Harmonic @ 3m	
ANT	802.11b CH01 2412MHz	
2	Horizontal	Vertical
Peak Avg.	 <p>Site : 03CH11-14Y Condition : PEAK_74 3m HORN 9120D-HF HORIZONTAL</p>	 <p>Site : 03CH11-14Y Condition : PEAK_74 3m HORN 9120D-HF VERTICAL</p>



WIFI	2.4GHz 2400~2483.5MHz Harmonic @ 3m	
ANT	802.11b CH02 2417MHz	
2	Horizontal	Vertical
Peak Avg.	<p>Site : 03CH11-14F Condition : PEAK_74 3m HORN 91200-HF HORIZONTAL</p>	<p>Site : 03CH11-14F Condition : PEAK_74 3m HORN 91200-HF VERTICAL</p>

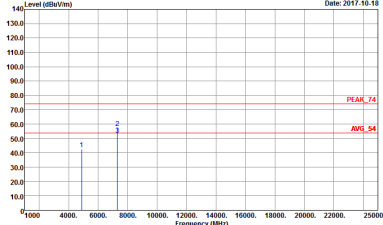
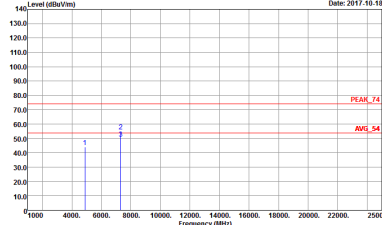

WIFI	2.4GHz 2400~2483.5MHz Harmonic @ 3m	
ANT	802.11b CH06 2437MHz	
2	Horizontal	Vertical
Peak Avg.	 <p>Site : 03CH11-14F Condition : PEAK_74 3m HORN 91200-HF HORIZONTAL</p>	 <p>Site : 03CH11-14F Condition : PEAK_74 3m HORN 91200-HF VERTICAL</p>

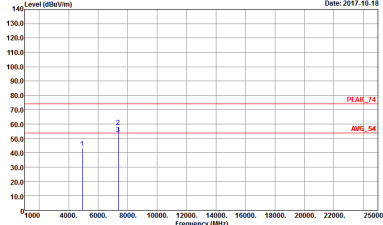
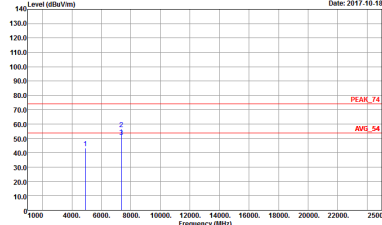

WIFI	2.4GHz 2400~2483.5MHz Harmonic @ 3m	
ANT	802.11b CH10 2457MHz	
2	Horizontal	Vertical
Peak Avg.	 <p>Site : 03CH11-14F Condition : PEAK_74 3m HORN 91200-HF HORIZONTAL</p>	 <p>Site : 03CH11-14F Condition : PEAK_74 3m HORN 91200-HF VERTICAL</p>

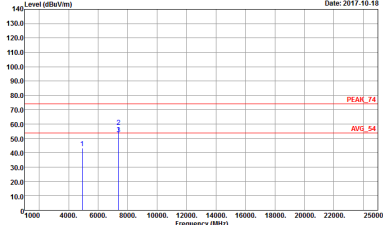
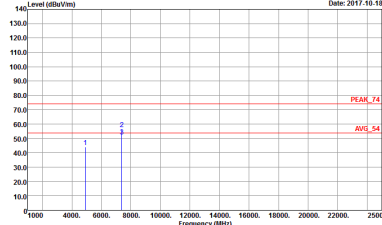

WIFI	2.4GHz 2400~2483.5MHz Harmonic @ 3m	
ANT	802.11b CH11 2462MHz	
2	Horizontal	Vertical
Peak Avg.	 <p>Site : 03CH11-4F Condition : PEAK_74 3m HORN 91200-HF HORIZONTAL</p>	 <p>Site : 03CH11-4F Condition : PEAK_74 3m HORN 91200-HF VERTICAL</p>



Emission below 1GHz

2.4GHz WIFI 802.11b (LF)

WIFI	2.4GHz 2400~2483.5MHz	
ANT	802.11b LF	
2	Horizontal	Vertical
QP / Peak	<p>Site : 03CH11-HY Condition : QP 3m 8E-LOG 6111D-LF_ETC HORIZONTAL</p>	<p>Site : 03CH11-HY Condition : QP 3m 8E-LOG 6111D-LF_ETC VERTICAL</p>

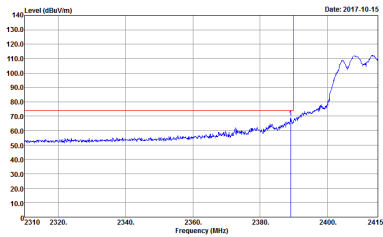
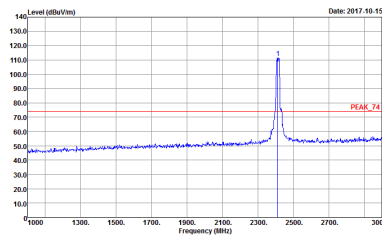
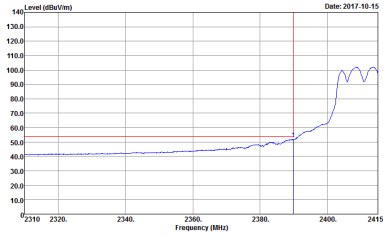
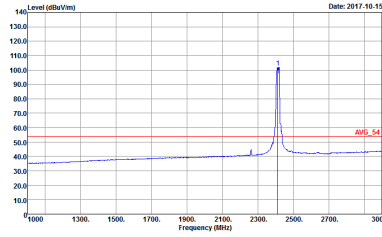

2.4GHz 2400~2483.5MHz
WIFI 802.11g (Band Edge @ 3m)

WIFI	2.4GHz 2400~2483.5MHz Band Edge @ 3m	
ANT	802.11g CH01 2412MHz	
1+2	Horizontal	Fundamental
Peak	 <p>Site : 03CHI1-HY Condition : PEAK_BE_74 3m HORN 9120D-HF HORIZONTAL</p>	 <p>Site : 03CHI1-HY Condition : PEAK_74 3m HORN 9120D-HF HORIZONTAL</p>
Avg.	 <p>Site : 03CHI1-HY Condition : AV6_BE_54 3m HORN 9120D-HF HORIZONTAL</p>	 <p>Site : 03CHI1-HY Condition : AV6_54 3m HORN 9120D-HF HORIZONTAL</p>



WIFI	2.4GHz 2400~2483.5MHz Band Edge @ 3m	
ANT	802.11g CH01 2412MHz	
1+2	Vertical	Fundamental
Peak	<p>Site : 03CHI1-HY Condition : PEAK_BE_74 3m HORN 9120D-HF VERTICAL</p>	<p>Site : 03CHI1-HY Condition : PEAK_74 3m HORN 9120D-HF VERTICAL</p>
Avg.	<p>Site : 03CHI1-HY Condition : AV6_BE_54 3m HORN 9120D-HF VERTICAL</p>	<p>Site : 03CHI1-HY Condition : AV6_54 3m HORN 9120D-HF VERTICAL</p>



WIFI	2.4GHz 2400~2483.5MHz Band Edge @ 3m	
ANT	802.11g CH02 2417MHz	
1+2	Horizontal	Fundamental
Peak	<p>Site : 03CH11-HY Condition : PEAK_BE_74 3m HORN 91200-HF HORIZONTAL</p>	<p>Site : 03CH11-HY Condition : PEAK_74 3m HORN 91200-HF HORIZONTAL</p>
Avg.	<p>Site : 03CH11-HY Condition : AV6_BE_54 3m HORN 91200-HF HORIZONTAL</p>	<p>Site : 03CH11-HY Condition : AV6_54 3m HORN 91200-HF HORIZONTAL</p>



WIFI	2.4GHz 2400~2483.5MHz Band Edge @ 3m	
ANT	802.11g CH02 2417MHz	
1+2	Vertical	Fundamental
Peak	<p>Site : 03CH11-HY Condition : PEAK_BE_74 3m HORN 91200-HF VERTICAL</p>	<p>Site : 03CH11-HY Condition : PEAK_74 3m HORN 91200-HF VERTICAL</p>
Avg.	<p>Site : 03CH11-HY Condition : AV6_BE_54 3m HORN 91200-HF VERTICAL</p>	<p>Site : 03CH11-HY Condition : AV6_54 3m HORN 91200-HF VERTICAL</p>



WIFI	2.4GHz 2400~2483.5MHz Band Edge @ 3m	
ANT	802.11g CH06 2437MHz - L	
1+2	Horizontal	Fundamental
Peak	<p>Site : 03CHI1-HY Condition : PEAK_BE_74 3m HORN 9120D-HF HORIZONTAL</p>	<p>Site : 03CHI1-HY Condition : PEAK_74 3m HORN 9120D-HF HORIZONTAL</p>
Avg.	<p>Site : 03CHI1-HY Condition : AV6_BE_54 3m HORN 9120D-HF HORIZONTAL</p>	<p>Site : 03CHI1-HY Condition : AV6_54 3m HORN 9120D-HF HORIZONTAL</p>

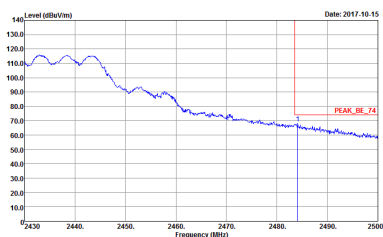
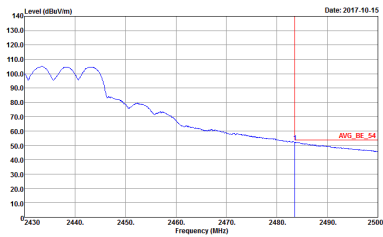

WIFI	2.4GHz 2400~2483.5MHz Band Edge @ 3m	
ANT	802.11g CH06 2437MHz - R	
1+2	Horizontal	Fundamental
<p>Peak</p>	 <p>Site : 03CH11-HY Condition : PEAK_BE_74 3m HORN 91200-HF HORIZONTAL</p>	<p>Left blank</p>
<p>Avg.</p>	 <p>Site : 03CH11-HY Condition : AVG_BE_54 3m HORN 91200-HF HORIZONTAL</p>	<p>Left blank</p>

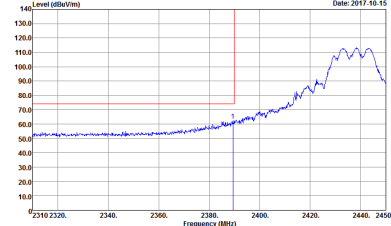
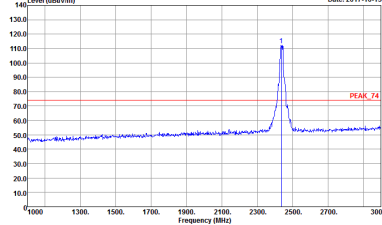
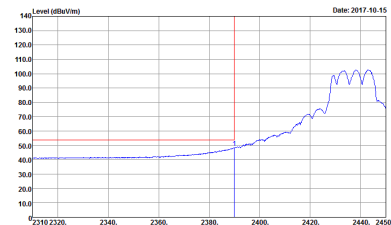
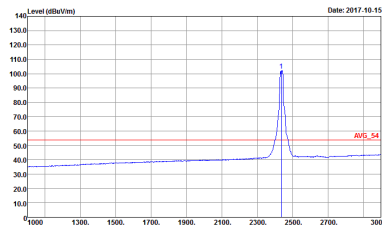

WIFI	2.4GHz 2400~2483.5MHz Band Edge @ 3m																																	
ANT	802.11g CH06 2437MHz - L																																	
1+2	Vertical	Fundamental																																
Peak	 <p>Site : 03CHI1-HY Condition : PEAK_BE_74 3m HORN 9120D-HF VERTICAL</p>	 <p>Site : 03CHI1-HY Condition : PEAK_74 3m HORN 9120D-HF VERTICAL Detector : Peak Pretest : #FWF3375 EUT : NA Power : 120V/60Hz Model : RQ IMEI : NA SN : 19A401AE3717001X Mode : 11g_Tx_CH06 Data Rate : 6M Setting : 4 Plane : Z with NB #F1_RQ-DOE3-DOE3B2-S + cover</p> <table border="1"> <thead> <tr> <th>Over</th> <th>Limit</th> <th>ReadAntenna</th> <th>Cable</th> <th>Preamp</th> <th>A/Pos</th> <th>T/Pos</th> <th>Remark</th> </tr> <tr> <th>Freq</th> <th>Level</th> <th>Limit</th> <th>Line</th> <th>Level Factor</th> <th>Loss Factor</th> <th></th> <th></th> </tr> <tr> <th>MHz</th> <th>dBuV/m</th> <th>dB</th> <th>dBuV/m</th> <th>dB/m</th> <th>dB</th> <th>cm</th> <th>deg</th> </tr> </thead> <tbody> <tr> <td>1 *</td> <td>2437.00</td> <td>112.40</td> <td>38.40</td> <td>74.00</td> <td>102.41</td> <td>27.27</td> <td>6.38 33.59 384 262 Peak</td> </tr> </tbody> </table>	Over	Limit	ReadAntenna	Cable	Preamp	A/Pos	T/Pos	Remark	Freq	Level	Limit	Line	Level Factor	Loss Factor			MHz	dBuV/m	dB	dBuV/m	dB/m	dB	cm	deg	1 *	2437.00	112.40	38.40	74.00	102.41	27.27	6.38 33.59 384 262 Peak
Over	Limit	ReadAntenna	Cable	Preamp	A/Pos	T/Pos	Remark																											
Freq	Level	Limit	Line	Level Factor	Loss Factor																													
MHz	dBuV/m	dB	dBuV/m	dB/m	dB	cm	deg																											
1 *	2437.00	112.40	38.40	74.00	102.41	27.27	6.38 33.59 384 262 Peak																											
Avg.	 <p>Site : 03CHI1-HY Condition : AV6_BE_54 3m HORN 9120D-HF VERTICAL</p>	 <p>Site : 03CHI1-HY Condition : AV6_54 3m HORN 9120D-HF VERTICAL</p>																																



WIFI	2.4GHz 2400~2483.5MHz Band Edge @ 3m	
ANT	802.11g CH06 2437MHz - R	
1+2	Vertical	Fundamental
Peak	<p>Site : 03CHI1-HY Condition : PEAK_BE_74 3m HORN 91200-HF VERTICAL</p>	Left Blank
Avg.	<p>Site : 03CHI1-HY Condition : AVG_BE_54 3m HORN 91200-HF VERTICAL</p>	Left Blank



WIFI	2.4GHz 2400~2483.5MHz Band Edge @ 3m	
ANT	802.11g CH10 2457MHz	
1+2	Horizontal	Fundamental
Peak	<p>Site : 03CH11-HY Condition : PEAK_BE_74 3m HORN 9120D-HF HORIZONTAL</p>	<p>Site : 03CH11-HY Condition : PEAK_74 3m HORN 9120D-HF HORIZONTAL</p>
Avg.	<p>Site : 03CH11-HY Condition : AVG_BE_54 3m HORN 9120D-HF HORIZONTAL</p>	<p>Site : 03CH11-HY Condition : AVG_54 3m HORN 9120D-HF HORIZONTAL</p>



WIFI	2.4GHz 2400~2483.5MHz Band Edge @ 3m	
ANT	802.11g CH10 2457MHz	
1+2	Vertical	Fundamental
Peak	<p>Site : 03CH11-HY Condition : PEAK_BE_74 3m HORN 91200-HF VERTICAL</p>	<p>Site : 03CH11-HY Condition : PEAK_74 3m HORN 91200-HF VERTICAL</p>
Avg.	<p>Site : 03CH11-HY Condition : AVG_BE_54 3m HORN 91200-HF VERTICAL</p>	<p>Site : 03CH11-HY Condition : AVG_54 3m HORN 91200-HF VERTICAL</p>



WIFI	2.4GHz 2400~2483.5MHz Band Edge @ 3m	
ANT	802.11g CH11 2462MHz	
1+2	Horizontal	Fundamental
Peak	<p>Site : 03CH11-HY Condition : PEAK_BE_74 3m HORN 9120D-HF HORIZONTAL</p>	<p>Site : 03CH11-HY Condition : PEAK_74 3m HORN 9120D-HF HORIZONTAL</p>
Avg.	<p>Site : 03CH11-HY Condition : AVG_BE_54 3m HORN 9120D-HF HORIZONTAL</p>	<p>Site : 03CH11-HY Condition : AVG_54 3m HORN 9120D-HF HORIZONTAL</p>



WIFI	2.4GHz 2400~2483.5MHz Band Edge @ 3m	
ANT	802.11g CH11 2462MHz	
1+2	Vertical	Fundamental
Peak	<p>Site : 03CH11-HY Condition : PEAK_BE_74 3m HORN 9120D-HF VERTICAL</p>	<p>Site : 03CH11-HY Condition : PEAK_74 3m HORN 9120D-HF VERTICAL</p>
Avg.	<p>Site : 03CH11-HY Condition : AVG_BE_54 3m HORN 9120D-HF VERTICAL</p>	<p>Site : 03CH11-HY Condition : AVG_54 3m HORN 9120D-HF VERTICAL</p>



2.4GHz 2400~2483.5MHz
WIFI 802.11n HT20 (Band Edge @ 3m)

WIFI	2.4GHz 2400~2483.5MHz Band Edge @ 3m	
ANT	802.11n HT20 CH01 2412MHz	
1+2	Horizontal	Fundamental
Peak	<p>Site : 03CH11-HY Condition : PEAK_BE_74 3m HORN 91200-HF HORIZONTAL</p>	<p>Site : 03CH11-HY Condition : PEAK_74 3m HORN 91200-HF HORIZONTAL</p>
Avg.	<p>Site : 03CH11-HY Condition : AV6_BE_54 3m HORN 91200-HF HORIZONTAL</p>	<p>Site : 03CH11-HY Condition : AV6_54 3m HORN 91200-HF HORIZONTAL</p>



WIFI	2.4GHz 2400~2483.5MHz Band Edge @ 3m	
ANT	802.11n HT20 CH01 2412MHz	
1+2	Vertical	Fundamental
Peak	<p>Site : 03CHI1-HY Condition : PEAK_BE_74 3m HORN 9120D-HF VERTICAL</p>	<p>Site : 03CHI1-HY Condition : PEAK_74 3m HORN 9120D-HF VERTICAL</p>
Avg.	<p>Site : 03CHI1-HY Condition : AV6_BE_54 3m HORN 9120D-HF VERTICAL</p>	<p>Site : 03CHI1-HY Condition : AV6_54 3m HORN 9120D-HF VERTICAL</p>



WIFI	2.4GHz 2400~2483.5MHz Band Edge @ 3m	
ANT	802.11n HT20 CH02 2417MHz	
1+2	Horizontal	Fundamental
Peak	<p>Site : 03CHI1-HY Condition : PEAK_BE_74 3m HORN 9120D-HF HORIZONTAL</p>	<p>Site : 03CHI1-HY Condition : PEAK_74 3m HORN 9120D-HF HORIZONTAL</p>
Avg.	<p>Site : 03CHI1-HY Condition : AV6_BE_54 3m HORN 9120D-HF HORIZONTAL</p>	<p>Site : 03CHI1-HY Condition : AV6_54 3m HORN 9120D-HF HORIZONTAL</p>



WIFI	2.4GHz 2400~2483.5MHz Band Edge @ 3m	
ANT	802.11n HT20 CH02 2417MHz	
1+2	Vertical	Fundamental
Peak	<p>Site : 03CH11-HY Condition : PEAK_BE_74 3m HORN 91200-HF VERTICAL</p>	<p>Site : 03CH11-HY Condition : PEAK_74 3m HORN 91200-HF VERTICAL</p>
Avg.	<p>Site : 03CH11-HY Condition : AV6_BE_54 3m HORN 91200-HF VERTICAL</p>	<p>Site : 03CH11-HY Condition : AV6_54 3m HORN 91200-HF VERTICAL</p>



WIFI	2.4GHz 2400~2483.5MHz Band Edge @ 3m	
ANT	802.11n HT20 CH06 2437MHz - L	
1+2	Horizontal	Fundamental
Peak	<p>Site : 03CH11-HY Condition : PEAK_BE_74 3m HORN 9120D-HF HORIZONTAL</p>	<p>Site : 03CH11-HY Condition : PEAK_74 3m HORN 9120D-HF HORIZONTAL</p>
Avg.	<p>Site : 03CH11-HY Condition : AV6_BE_54 3m HORN 9120D-HF HORIZONTAL</p>	<p>Site : 03CH11-HY Condition : AV6_54 3m HORN 9120D-HF HORIZONTAL</p>

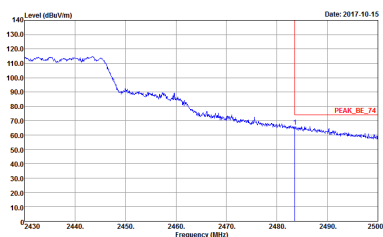
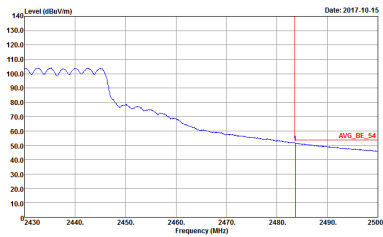

WIFI	2.4GHz 2400~2483.5MHz Band Edge @ 3m	
ANT	802.11n HT20 CH06 2437MHz - R	
1+2	Horizontal	Fundamental
<p>Peak</p>	 <p>Site : 03CH11-HY Condition : PEAK_BE_74 3m HORN 91200-HF HORIZONTAL</p>	<p>Left blank</p>
<p>Avg.</p>	 <p>Site : 03CH11-HY Condition : AVG_BE_54 3m HORN 91200-HF HORIZONTAL</p>	<p>Left blank</p>



WIFI	2.4GHz 2400~2483.5MHz Band Edge @ 3m	
ANT	802.11n HT20 CH06 2437MHz - L	
1+2	Vertical	Fundamental
Peak	<p>Site : 03CH11-HY Condition : PEAK_BE_74 3m HORN 91200-HF VERTICAL</p>	<p>Site : 03CH11-HY Condition : PEAK_74 3m HORN 91200-HF VERTICAL</p>
Avg.	<p>Site : 03CH11-HY Condition : AV6_BE_54 3m HORN 91200-HF VERTICAL</p>	<p>Site : 03CH11-HY Condition : AV6_54 3m HORN 91200-HF VERTICAL</p>

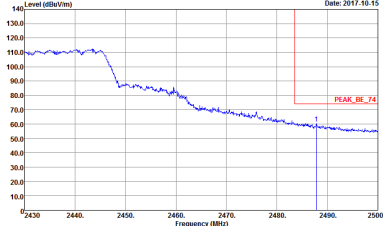
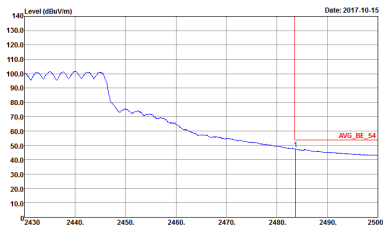

WIFI	2.4GHz 2400~2483.5MHz Band Edge @ 3m	
ANT	802.11n HT20 CH06 2437MHz - R	
1+2	Vertical	Fundamental
<p>Peak</p>	 <p>Site : 03CHI1-HY Condition : PEAK_BE_74 3m HORN 91200-HF VERTICAL</p>	<p>Left Blank</p>
<p>Avg.</p>	 <p>Site : 03CHI1-HY Condition : AVG_BE_54 3m HORN 91200-HF VERTICAL</p>	<p>Left Blank</p>

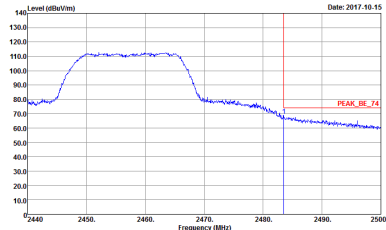
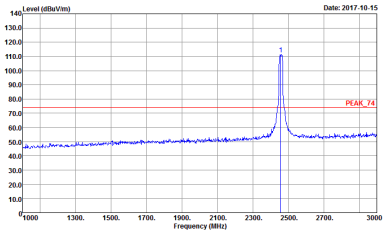
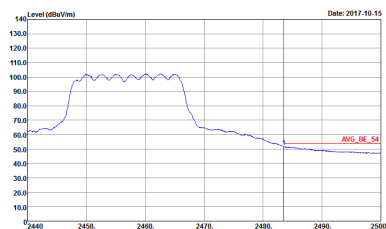
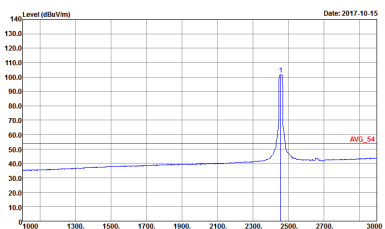

WIFI	2.4GHz 2400~2483.5MHz Band Edge @ 3m	
ANT	802.11n HT20 CH10 2457MHz	
1+2	Horizontal	Fundamental
Peak	 <p>Site : 03CH11-HY Condition : PEAK_BE_74 3m HORN 91200-HF HORIZONTAL</p>	 <p>Site : 03CH11-HY Condition : PEAK_74 3m HORN 91200-HF HORIZONTAL</p>
Avg.	 <p>Site : 03CH11-HY Condition : AV6_BE_54 3m HORN 91200-HF HORIZONTAL</p>	 <p>Site : 03CH11-HY Condition : AV6_54 3m HORN 91200-HF HORIZONTAL</p>



WIFI	2.4GHz 2400~2483.5MHz Band Edge @ 3m	
ANT	802.11n HT20 CH10 2457MHz	
1+2	Vertical	Fundamental
Peak	<p>Site : 03CH11-HY Condition : PEAK_BE_74 3m HORN 9120D-HF VERTICAL</p>	<p>Site : 03CH11-HY Condition : PEAK_74 3m HORN 9120D-HF VERTICAL</p>
Avg.	<p>Site : 03CH11-HY Condition : AVG_BE_54 3m HORN 9120D-HF VERTICAL</p>	<p>Site : 03CH11-HY Condition : AVG_54 3m HORN 9120D-HF VERTICAL</p>



WIFI	2.4GHz 2400~2483.5MHz Band Edge @ 3m	
ANT	802.11n HT20 CH11 2462MHz	
1+2	Horizontal	Fundamental
Peak	<p>Site : 03CH11-HY Condition : PEAK_BE_74 3m HORN 91200-HF HORIZONTAL</p>	<p>Site : 03CH11-HY Condition : PEAK_74 3m HORN 91200-HF HORIZONTAL</p>
Avg.	<p>Site : 03CH11-HY Condition : AV6_BE_54 3m HORN 91200-HF HORIZONTAL</p>	<p>Site : 03CH11-HY Condition : AV6_54 3m HORN 91200-HF HORIZONTAL</p>



WIFI	2.4GHz 2400~2483.5MHz Fundamental @ 3m	
ANT	802.11n HT20 CH11 2462MHz	
1+2	Vertical	Fundamental
Peak	<p>Site : 03CH11-HY Condition : PEAK_BE_74 3m HORN 91200-HF VERTICAL</p>	<p>Site : 03CH11-HY Condition : PEAK_74 3m HORN 91200-HF VERTICAL</p>
Avg.	<p>Site : 03CH11-HY Condition : AVG_BE_54 3m HORN 91200-HF VERTICAL</p>	<p>Site : 03CH11-HY Condition : AVG_54 3m HORN 91200-HF VERTICAL</p>



**2.4GHz 2400~2483.5MHz
WIFI 802.11g (Harmonic @ 3m)**

WIFI	2.4GHz 2400~2483.5MHz Harmonic @ 3m	
ANT	802.11g CH01 2412MHz	
1+2	Horizontal	Vertical
Peak Avg.	<p>Site : 03CH11-14Y Condition : PEAK_74 3m HORN 9120D-HF HORIZONTAL</p>	<p>Site : 03CH11-14Y Condition : PEAK_74 3m HORN 9120D-HF VERTICAL</p>

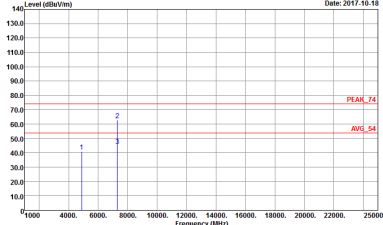
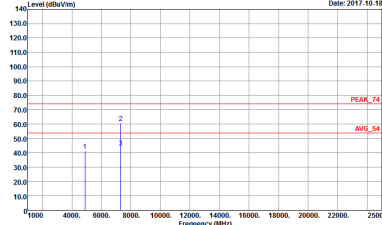

WIFI	2.4GHz 2400~2483.5MHz Harmonic @ 3m	
ANT	802.11g CH06 2437MHz	
1+2	Horizontal	Vertical
<p>Peak</p> <p>Avg.</p>	 <p>Site : 03CH11-4F Condition : PEAK_74 3m HORN 91200-HF HORIZONTAL</p>	 <p>Site : 03CH11-4F Condition : PEAK_74 3m HORN 91200-HF VERTICAL</p>

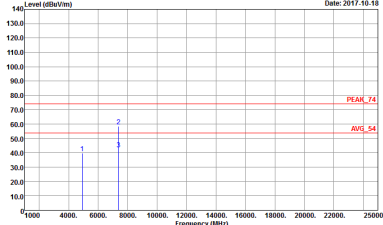
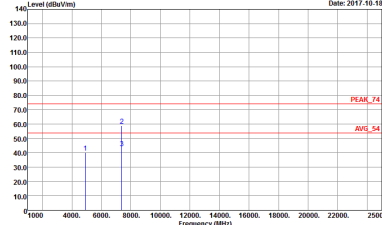

WIFI	2.4GHz 2400~2483.5MHz Harmonic @ 3m	
ANT	802.11g CH11 2462MHz	
1+2	Horizontal	Vertical
Peak Avg.	 <p>Site : 03CH11-4F Condition : PEAK_74 3m HORN 91200-HF HORIZONTAL</p>	 <p>Site : 03CH11-4F Condition : PEAK_74 3m HORN 91200-HF VERTICAL</p>



2.4GHz 2400~2483.5MHz
WIFI 802.11n HT20 (Harmonic @ 3m)

Table with 3 columns: WIFI (2.4GHz 2400~2483.5MHz Harmonic @ 3m), ANT (802.11n HT20 CH01 2412MHz), and 1+2 (Horizontal/Vertical). It contains two graphs showing Level (dBuV/m) vs Frequency (MHz) for Peak and Avg. measurements.



WIFI	2.4GHz 2400~2483.5MHz Harmonic @ 3m	
ANT	802.11n HT20 CH06 2437MHz	
1+2	Horizontal	Vertical
Peak Avg.	<p>Site : 03CH11-14F Condition : PEAK_74 3m HORN 91200-HF HORIZONTAL</p>	<p>Site : 03CH11-14F Condition : PEAK_74 3m HORN 91200-HF VERTICAL</p>



WIFI	2.4GHz 2400~2483.5MHz Harmonic @ 3m	
ANT	802.11n HT20 CH11 2462MHz	
1+2	Horizontal	Vertical
Peak Avg.	<p>Site : 03CH11-4F Condition : PEAK_74 3m HORN 91200-HF HORIZONTAL</p>	<p>Site : 03CH11-4F Condition : PEAK_74 3m HORN 91200-HF VERTICAL</p>

**Emission below 1GHz
2.4GHz WIFI 802.11g (LF)**

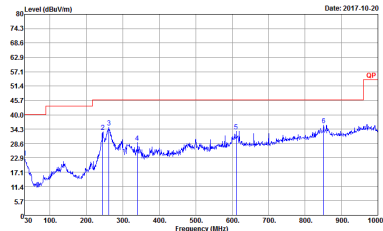
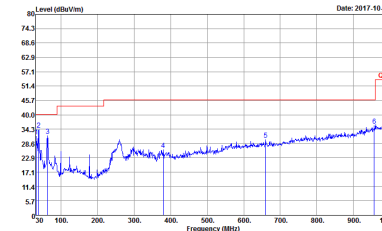
WIFI	2.4GHz 2400~2483.5MHz	
ANT	802.11g LF	
1+2	Horizontal	Vertical
QP / Peak	 <p>Site : 03CH11-HY Condition : QP-3m 81-LOG-6111D-LF_ETC HORIZONTAL</p>	 <p>Site : 03CH11-HY Condition : QP-3m 81-LOG-6111D-LF_ETC VERTICAL</p>



Appendix D. Duty Cycle Plots

Antenna	Band	Duty Cycle(%)	T(us)	1/T(kHz)	VBW Setting
1	802.11b	98.62	-	-	10Hz
1	802.11g	92.86	1430	0.70	1kHz
1	2.4GHz 802.11n HT20	93.08	1345	0.74	1kHz
1	2.4GHz 802.11ac20	92.47	1350	0.74	1kHz
2	802.11b	98.62	-	-	10Hz
2	802.11g	92.86	1430	0.70	1kHz
2	2.4GHz 802.11n HT20	93.06	1340	0.75	1kHz
2	2.4GHz 802.11ac20	92.47	1350	0.74	1kHz
1+2	802.11g for Ant. 1	92.86	1430	0.70	1kHz
1+2	2.4GHz 802.11n HT20 for Ant. 1	93.06	1340	0.75	1kHz
1+2	2.4GHz 802.11ac20 for Ant. 1	92.41	1340	0.75	1kHz
1+2	802.11g for Ant. 2	93.23	1432	0.70	1kHz
1+2	2.4GHz 802.11n HT20 for Ant. 2	93.06	1340	0.75	1kHz
1+2	2.4GHz 802.11ac20 for Ant. 2	93.10	1350	0.74	1kHz



<Ant. 1>

802.11b

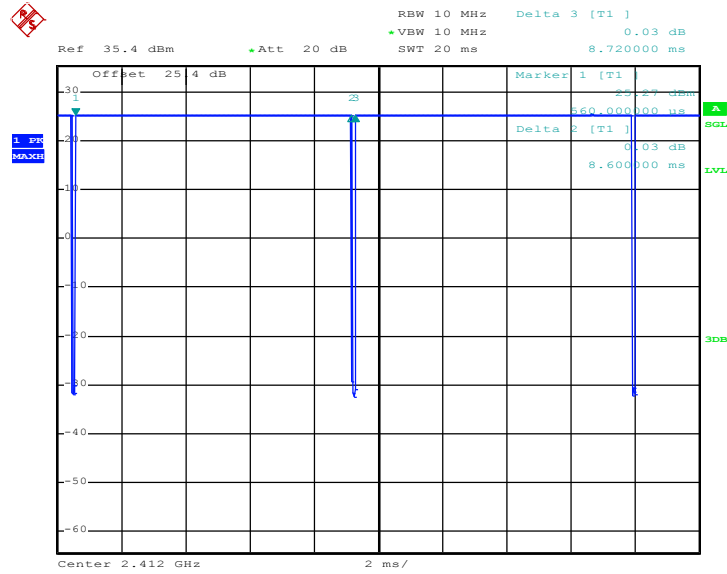

Date: 18.OCT.2017 15:26:23

802.11g

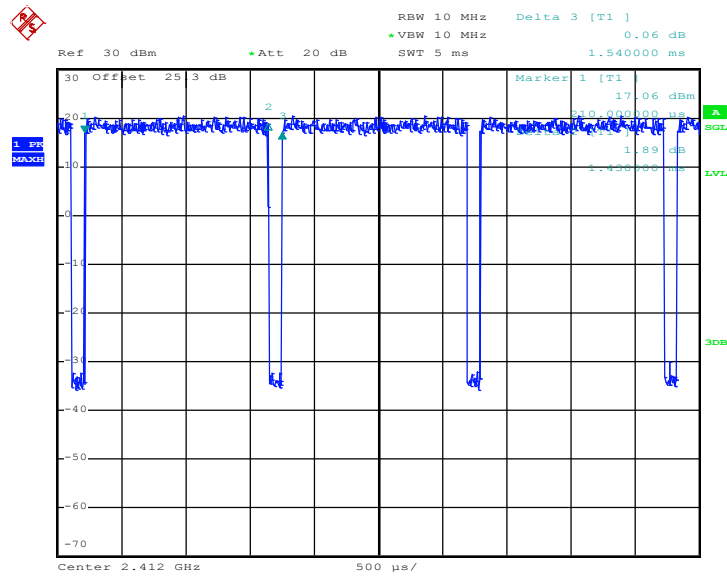

Date: 24.OCT.2017 19:46:07



802.11n HT20

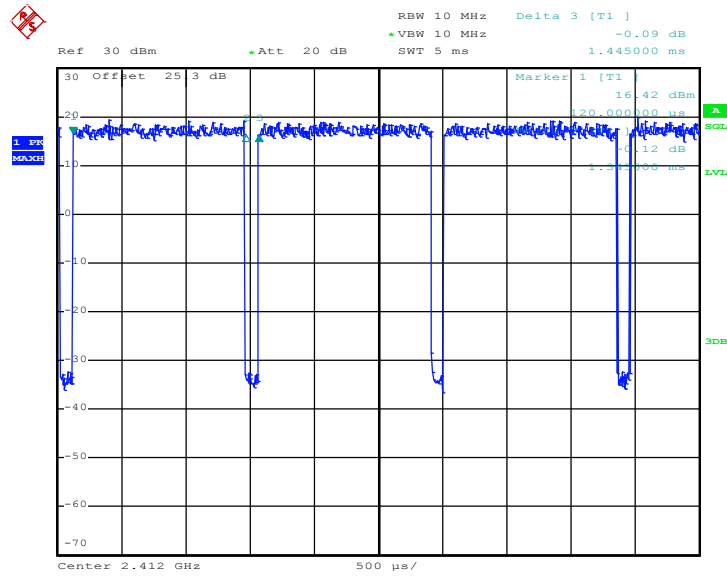

Date: 24.OCT.2017 20:03:22

802.11ac VHT20

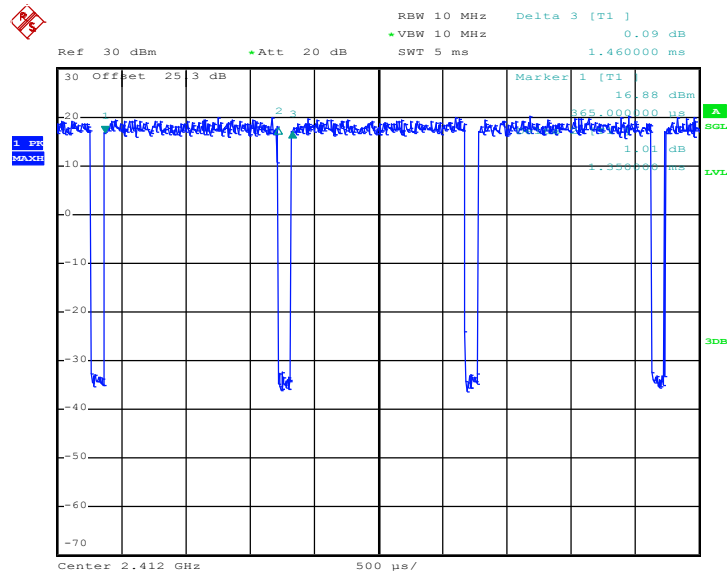

Date: 24.OCT.2017 20:22:07



<Ant. 2>

802.11b

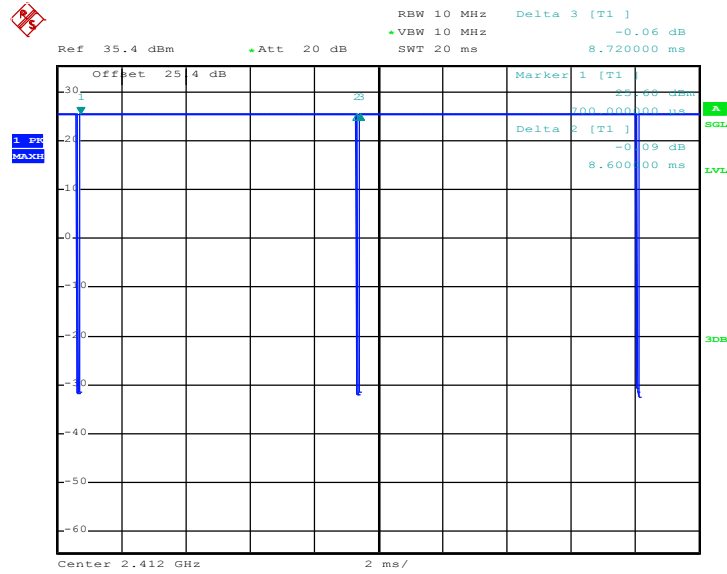

Date: 18.OCT.2017 15:58:47

802.11g

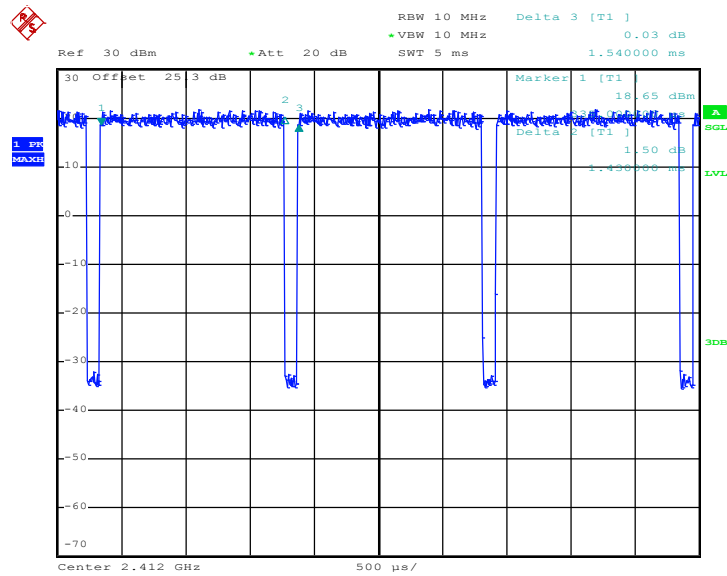

Date: 24.OCT.2017 19:47:15



802.11n HT20

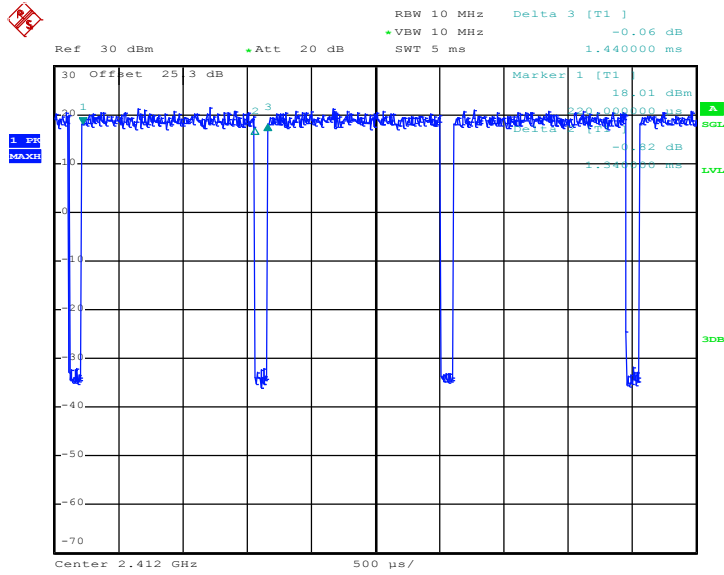

Date: 24.OCT.2017 20:04:22

802.11ac VHT20

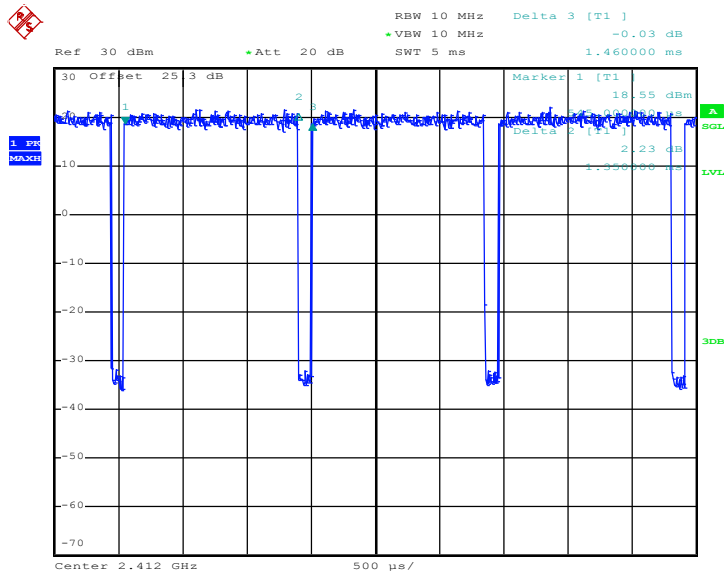

Date: 24.OCT.2017 20:23:02



<MIMO Ant. 1>

802.11g

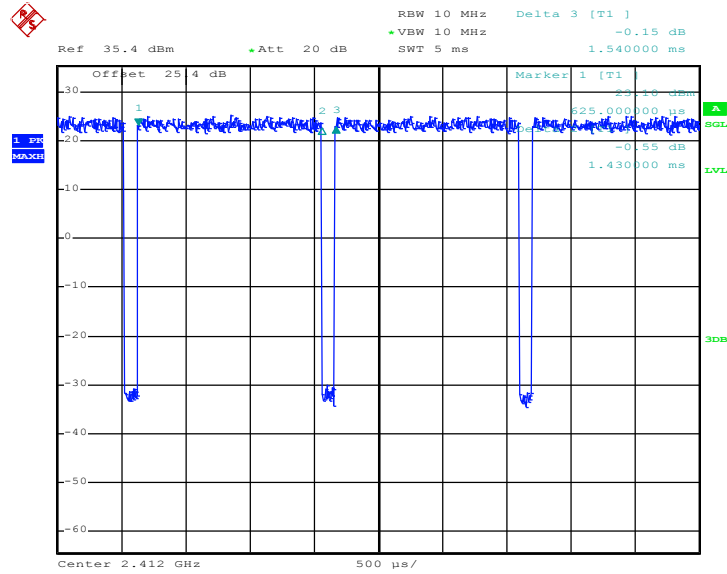

Date: 18.OCT.2017 17:47:28

802.11n HT20

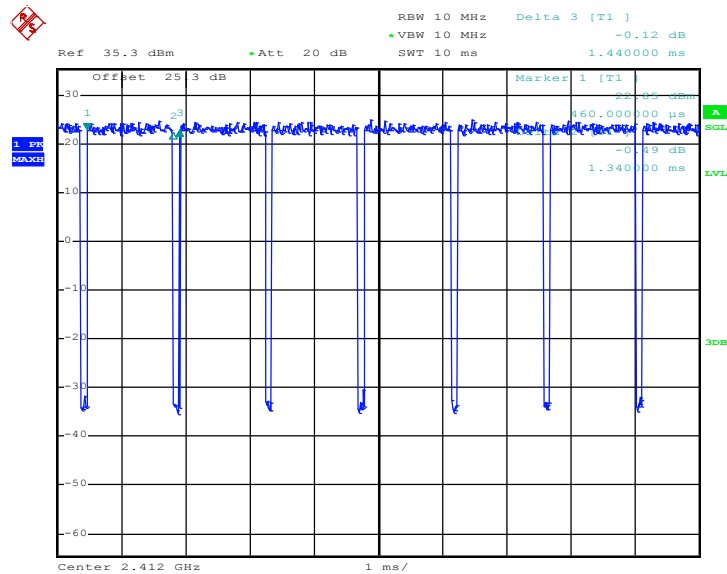

Date: 18.OCT.2017 20:19:36



802.11ac VHT20

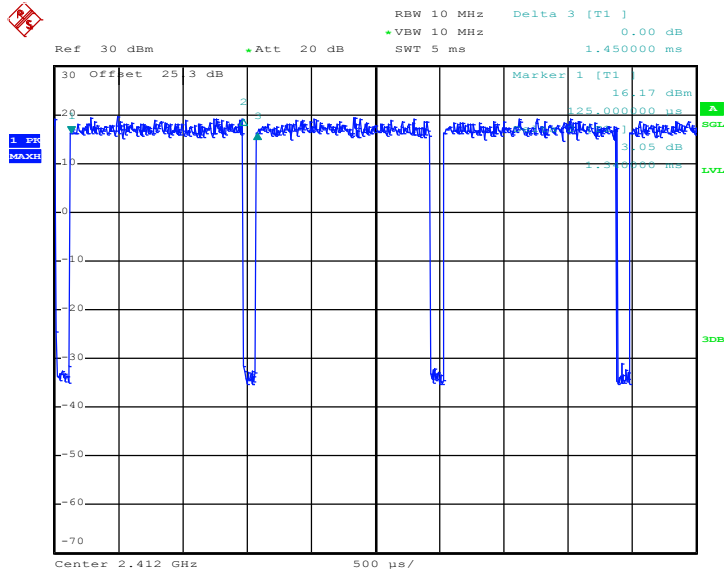

Date: 24.OCT.2017 20:26:15



<MIMO Ant. 2>

802.11g

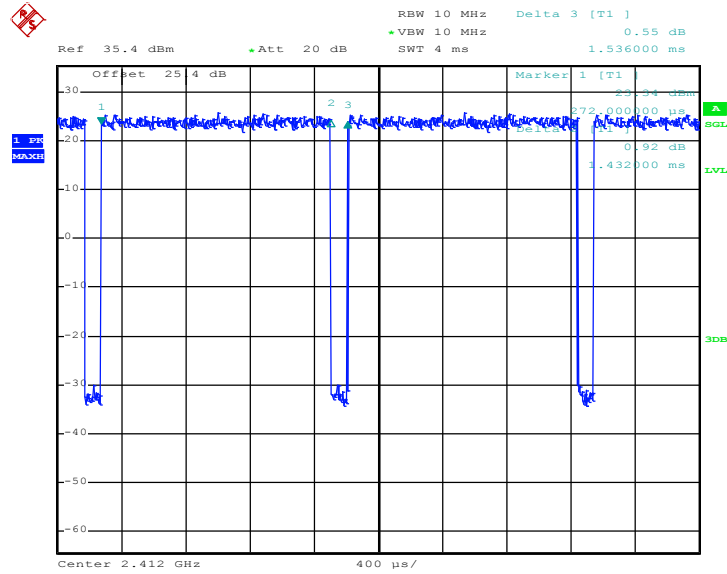

Date: 18.OCT.2017 17:48:42

802.11n HT20

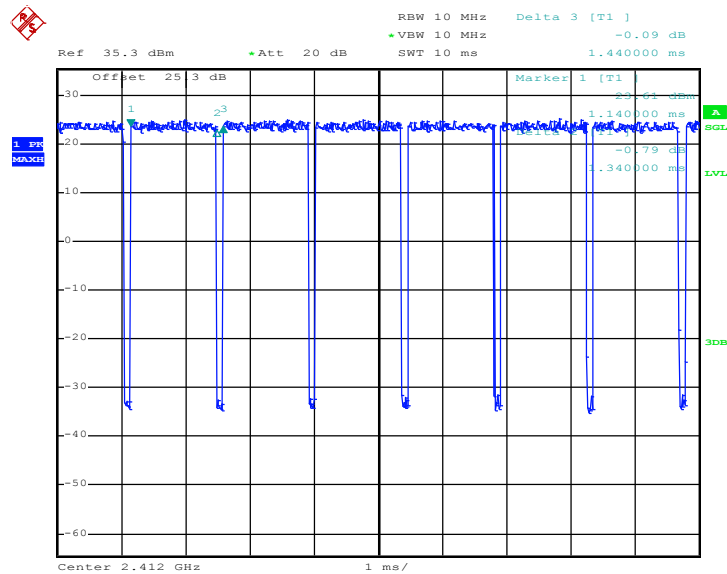

Date: 18.OCT.2017 20:20:56



802.11ac VHT20

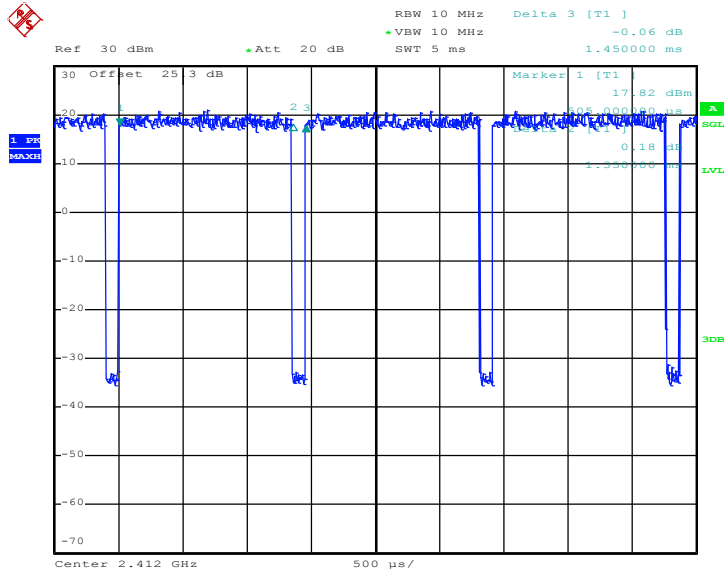

Date: 24.OCT.2017 20:26:48